



21354



twilight

Booklet available in English
Livret disponible en français
Folleto disponible en español

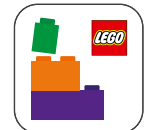

LEGO® Builder

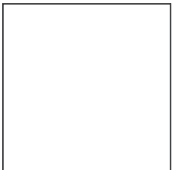



WE'RE MAKING OUR PACKAGING MORE SUSTAINABLE

We're transitioning from single-use plastic to paper-based packaging. As we progress, you may find a mix of paper and plastic in our boxes.

NOUS RENDONS NOS EMBALLAGES PLUS DURABLES

Nous passons des emballages en plastique à usage unique aux emballages à base de papier. Durant la transition, vous pourriez trouver un mélange de papier et de plastique dans nos boîtes.

QUEREMOS HACER MÁS SUSTENTABLES NUESTROS MATERIALES DE EMBALAJE

Estamos cambiando las bolsas de plástico desechables por bolsas con base de papel. Conforme avanzamos en este propósito, puedes encontrar una mezcla de papel y de plástico en nuestras cajas.

LEGO.com/sustainable-packaging



BUILDER



Apple and the Apple logo are trademarks of Apple Inc., registered in the U.S. and other countries and regions. App Store is a service mark of Apple Inc. Google Play and the Google Play logo are trademarks of Google LLC. Tencent and the Tencent logo are trademarks of Tencent Inc.

LEGO.com/devicecheck



LEGO® Builder

Meet the fan designer

LEGO® Ideas fan designer Nick Micheels (LEGO Ideas name LobsterThermidor) lives in Sacramento, California. By day, he works at a school. By night, he roams local musical theaters as a drummer/percussionist (though not, to our knowledge, as a vampire).

"Since emerging from my LEGO 'dark ages' a few years ago, LEGO building has become a fun and calming experience for myself and my family. It's a contagious hobby, and I hope to infect all my loved ones. I didn't discover The Twilight Saga as a teen, but by now I have watched the movies to a point where I can almost recite every line! I thought it would be funny to translate these movies and characters into LEGO form and infuse a little humor into it. The actual house used in the movies is a stunning piece of architecture. The second floor is a major focal point, so I started with the second-floor facade. I

studied the architecture of the movie version and then planned my own interpretative blueprint. I thought of scenes from the movies and knew I needed the staircase with room for the graduation caps, a piano, Edward's room and the kitchen, so a lot of the design effort went into deciding how I could creatively squeeze all those scenes in. It took a few months to get it all done, and then it was pretty unreal to witness the project take off. The idea went live on February 3rd in the morning and reached 10,000 supporters by midday on the 4th. There was a huge and amazing community of supporters that I didn't even know was out there, sharing it everywhere on social media. There are so many amazing LEGO fan creators, and the entire LEGO Ideas process from fan design to promoting the final product is really inspiring. Thank you so much to everyone who shared and supported the idea!"

"This is the one place we don't have to hide."

- Edward Cullen, *Twilight* (2008)



*A period that sometimes occurs after you stop playing with LEGO bricks as a child, before rediscovering your passion for building as an adult.



Fan designer Nick with his original model

Le concepteur amateur Nick avec son modèle original

Nick, el fan diseñador, con su modelo original



Rencontre avec le concepteur amateur

Le concepteur amateur de LEGO® Ideas Nick Micheels (pseudonyme LEGO Ideas : LobsterThermidor) vit à Sacramento, en Californie. Le jour, il travaille dans une école. Le soir, il fréquente les théâtres musicaux locaux en tant que batteur/percussionniste (mais pas, à notre connaissance, en tant que vampire).

« Depuis la fin de mon "âge des ténèbres" LEGO il y a quelques années, la construction LEGO est devenue une expérience amusante et apaisante pour ma famille et moi. C'est un passe-temps contagieux, et j'espère le transmettre à tous ceux que j'aime. Je n'ai pas découvert Twilight lorsque j'étais adolescent, mais j'ai maintenant regardé les films à un point tel que je peux réciter presque chaque ligne ! J'ai pensé qu'il serait amusant de transposer ces films et ces personnages sous forme de LEGO et d'y insuffler un peu d'humour. La maison utilisée dans les films est une pièce d'architecture étonnante. Le deuxième étage est un point d'intérêt majeur ; c'est pourquoi j'ai commencé

par sa façade. J'ai étudié l'architecture de la version cinématographique, puis j'ai élaboré mon propre plan d'interprétation. J'ai pensé à des scènes des films et je savais que j'avais besoin d'un escalier et d'assez d'espace pour les chapeaux, un piano, la chambre d'Edward et la cuisine, alors une grande partie de l'effort de conception a consisté à décider comment je pourrais insérer toutes ces scènes de manière créative. Il a fallu quelques mois pour que tout soit prêt, et ça a été assez surréaliste de voir le projet prendre autant d'ampleur. L'idée a été mise en ligne le 3 février au matin et a atteint 10 000 votes le 4 à la mi-journée. Il y avait une énorme et incroyable communauté de partisans dont je ne soupçonnais même pas l'existence et qui partageait le projet partout sur les médias sociaux. Il y a tellement d'incroyables créateurs amateurs de LEGO, et l'ensemble du processus LEGO Ideas, de la conception par l'amateur à la promotion du produit final, est vraiment inspirant. Merci beaucoup à tous ceux qui ont partagé et soutenu l'idée ! »

* Une période qui survient parfois après avoir arrêté de jouer avec des briques LEGO pendant l'enfance, avant de redécouvrir sa passion pour la construction à l'âge adulte.

« C'est le seul endroit où on n'a pas besoin de se cacher. »

— Edward Cullen, *Twilight : La fascination* (2008)



Conoce al fan diseñador

El fan diseñador de LEGO® Ideas Nick Micheels (apodado LobsterThermidor en LEGO Ideas) vive en Sacramento (California). Durante el día, trabaja en una escuela. Y por la noche, recorre los teatros musicales locales como baterista/percusionista (aunque, hasta donde sabemos, no como vampiro).

“Desde que salí de mi 'edad oscura'* de LEGO hace unos años, construir con LEGO se ha convertido en una experiencia divertida y relajante para mí y mi familia. Es un pasatiempo contagioso, y espero transmitírselo a todos mis seres queridos. No descubrí la saga de Crepúsculo en mi adolescencia, pero ahora he visto las películas tantas veces que casi puedo recitar de memoria cada una de sus líneas. Pensé que sería gracioso convertir las cintas y sus personajes al formato LEGO e infundirles un poco de humor. La casa que se usó durante la grabación de estos largometrajes es una impresionante obra de arquitectura. El segundo piso es un punto focal importante, así que empecé por su fachada. Estudié la arquitectura de la versión que se aprecia en la pantalla y luego tracé un plano basado en mi propia interpretación. Repasar en mi mente las escenas de las películas me hizo darme cuenta de que necesitaba dar a la escalera el espacio suficiente para los birretes de graduación, así como incluir un piano, el cuarto de Edward y la cocina. Eso me impulsó a dedicar gran parte del esfuerzo de diseño a decidir cómo podría incluir creativamente todas esas escenas. Me tomó algunos meses completar todo y, después, fue casi mágico ver cómo el proyecto empezaba a alzar el vuelo. La idea se lanzó en vivo el 3 de febrero por la mañana y alcanzó los 10.000 seguidores al mediodía del día 4. Una enorme y asombrosa comunidad de seguidores que yo ni siquiera sabía que existía se dio a la tarea de compartir el modelo por todos los rincones de las redes sociales. Hay muchísimos creadores LEGO increíbles entre los fans, y todo el proceso de LEGO Ideas, desde el diseño por parte del fan hasta la promoción del producto final, es verdaderamente inspirador. ¡Muchas gracias a todos los que compartieron y apoyaron la idea!”

* Un período que a veces ocurre después de dejar de jugar con bricks LEGO en la niñez, antes de redescubrir tu pasión por construir como adulto.

“ No tenemos que escondernos aquí ”.

— Edward Cullen, *Crepúsculo* (2008)

Welcome to the Cullen House

From *Twilight* to *The Twilight Saga: Breaking Dawn – Part 2*, Isabella Marie Swan, Edward Cullen, Jacob Black and their families of vampires and wolf packs continue to captivate audiences across the world. Whether we're #TeamEdward or #TeamJacob (can't we just love them both equally?), we can at least agree on some of our favorite scenes and defining moments in the saga. The Cullen House plays host to Bella's first real encounter with the awe-inspiring vampire world, her wedding to Edward, her transition after the birth of their daughter, and fateful negotiations between international vampire covens and Jacob's wolf pack. Secluded from the world of mortals, its striking, timeless architecture offers serenity and privacy for the Cullen family and even a practical vantage point for leaping between treetops to enjoy the spectacular surrounding nature!

Bienvenue à la maison Cullen

De *Twilight : La fascination* à *La saga Twilight : Révélation, partie 2*, Isabella Marie Swan, Edward Cullen, Jacob Black et leurs familles de vampires et de loups continuent de captiver les spectateurs du monde entier. Que nous soyons #ClanEdward ou #ClanJacob (ne pouvons-nous pas les aimer à égalité ?), nous pouvons au moins nous entendre sur les scènes et les moments les plus marquants de la saga. La maison Cullen est le théâtre du premier contact de Bella avec le fascinant monde des vampires, de son mariage avec Edward, de sa transition après la naissance de leur fille et des négociations fatigantes entre les groupes internationaux de vampires et la meute de loups de Jacob. À l'écart du monde des mortels, la maison à l'architecture saisissante et intemporelle offre sérénité et intimité à la famille Cullen, et même un point idéal pour sauter entre les cimes des arbres afin de profiter de la nature environnante spectaculaire !

“What did you expect? Coffins and dungeons and moats?”

- Edward Cullen, *Twilight* (2008)

« Tu t'attendais à quoi ? Des cercueils, des donjons et un pont-levis ? »

- Edward Cullen, *Twilight : La fascination* (2008)

“¿Qué esperabas? ¿Calabozos, ataúdes, fosos?”

- Edward Cullen, *Crepúsculo* (2008)



re et dolore magna aliqua. Ut enim ad minim veniam, quis nostris nisi ut aliquip ex ea commodo consequat. Duis aute irure voluptate velit esse cillum dolore eu fugiat nulla pariatur. Exceptat non proident, sunt in culpa qui officia deserunt mollit anim

Te damos la bienvenida a la Casa de los Cullen

Desde *Crepúsculo* hasta *Crepúsculo, la saga: Amanecer – Parte 2*, Isabella Marie Swan, Edward Cullen, Jacob Black y sus familias de vampiros y manadas de lobos continúan cautivando a audiencias de todo el mundo. Aunque algunos seamos del #EquipoEdward y otros del #EquipoJacob (¿acaso no podemos amarlos a ambos por igual?), al menos podemos estar de acuerdo en algunas de nuestras escenas favoritas y momentos cruciales de la saga. La Casa de los Cullen es el escenario del primer encuentro real de Bella con el impresionante mundo de los vampiros, su boda con Edward, su transformación después del nacimiento de su hija y las negociaciones decisivas entre los aquelarres de vampiros de todo el mundo y la manada de lobos de Jacob. Alejada del mundo de los mortales, su impresionante e intemporal arquitectura ofrece serenidad y privacidad a la familia Cullen, además de un punto ventajoso y práctico para saltar entre las copas de los árboles y disfrutar de la espectacular naturaleza que los rodea!



Home to the Cullens

The Cullen House, Original House Design by Skylab Architecture, has an almost ethereal quality about it in the way that it seems to float among the trees, seamlessly blending in with the forest where the family can hunt their prey. An extension of the characters themselves, the house represents a refreshing portrayal of modern vampires who have spent lifetimes perfecting strategies to exist in harmony with their surroundings, communities and even natural enemies. Entirely devoid of coffins, dungeons and moats, this stunning structure takes the classic tales of vampires into a new era.

La maison des Cullen

Conçue par Skylab Architecture, la maison des Cullen possède un caractère presque éthéré, semblant flotter entre les arbres et se fondre harmonieusement dans la forêt, où la famille peut chasser ses proies. Prolongement des personnages eux-mêmes, la maison représente une image rafraîchissante des vampires modernes qui ont passé leur vie à perfectionner des stratégies pour exister en harmonie avec leur environnement, leurs communautés et même leurs ennemis naturels. Entièrement dépourvue de cercueils, de donjons et de ponts-levis, cette structure étonnante fait entrer les contes classiques de vampires dans une nouvelle ère.

El hogar de los Cullen

La Casa de los Cullen, cuyo diseño original fue creado por Skylab Architecture, parece flotar entre los árboles, lo que le confiere propiedades casi etéreas y le permite fusionarse perfectamente con el bosque donde la familia caza a sus presas. Como extensión de los personajes, la casa presenta un refrescante retrato de los vampiros modernos y su dedicación permanente a perfeccionar estrategias para convivir en armonía con su entorno, su comunidad e incluso sus enemigos naturales. Totalmente desprovista de calabozos, ataúdes y fosos, la impresionante estructura lleva los clásicos cuentos de vampiros a una nueva era.

Edward Cullen scribit epistolam quae dicit: Tam cito redibo, soles mihi tempus deesset. Respice post cor meum - e vobiscum.



Creative works of art

LEGO® Ideas sets are passion-driven creations – designed by fans, for fans. So, whether you're a fan of *The Twilight Saga* or LEGO building – or both, this set is skillfully crafted to be fun to build and inspiring to display. Hopefully, you will feel your creativity sparkle in the process! As you build your model, you can explore each floor and room and take time to make yourself feel at home here. Like its movie version, you will discover that this house holds a lot of secrets. From Edward's *Clair de Lune* album and music sheet to the baseball bat collection and grand piano, this LEGO Ideas version of the Cullen House is packed with references to iconic scenes from the saga, inside and out.

Des œuvres d'art créatives

Les ensembles LEGO® Ideas sont des créations empreintes de passion, conçues par des amateurs, pour des amateurs. Ainsi, que vous soyez amateur de *Twilight* ou de la construction LEGO (ou des deux), cet ensemble est habilement conçu pour être amusant à construire et inspirant à exposer. Nous espérons que vous sentirez votre créativité briller au cours du processus ! Au fur et à mesure que vous construisez votre modèle, vous pouvez explorer chaque étage et chaque pièce et prendre le temps d'y trouver votre place. À l'instar de son homologue cinématographique, cette maison recèle de nombreux secrets. De l'album *Clair de Lune* et de la partition d'Edward à la collection de battes de baseball et au piano à queue, cette version LEGO Ideas de la maison Cullen est remplie de références aux scènes emblématiques de la saga, à l'intérieur comme à l'extérieur.

Obras de arte creativas

Los sets LEGO® Ideas son creaciones impulsadas por la pasión: diseñadas por fans, para fans. Así que, ya seas fan de *Crepúsculo*, *la saga* o de construir con LEGO (o de ambas cosas), este set está diseñado con gran habilidad para hacer que sea divertido armarlo y llenar de inspiración a quienes lo contemplan una vez exhibido. ¡Esperamos que tu creatividad brille en el proceso! Mientras construyes el modelo, puedes explorar cada piso y habitación y tomarte el tiempo para sentirte como en casa. Al igual que la versión de la película, descubrirás que esta casa guarda muchísimos secretos. Desde el álbum de *Clair de lune* y la partitura musical de Edward hasta la colección de bates de béisbol y el gran piano, esta versión LEGO Ideas de la Casa de los Cullen está repleta de referencias a escenas icónicas de la saga, tanto por dentro como por fuera.



“ You better hold on tight, spider monkey.”

– Edward Cullen, *Twilight* (2008)

« Tu ferais mieux de t'accrocher, mon petit singe. »

– Edward Cullen, *Twilight : La fascination* (2008)

“ Sujétate bien, mono araña”.

– Edward Cullen, *Crepúsculo* (2008)



ut labore et dolore magna aliqua. Ut enim ad
amco laboris nisi ut aliquip ex ea commodo consequat. Duis aute irure
derit in voluptate velit esse cillum dolore eu fugiat nulla
cupidatat non proident, sunt in culpa qui officia deserunt mollit anim id est laborum

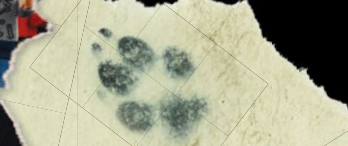

Let's take you on a tour

With seven LEGO® minifigure characters, you can arrange your model to display your favorite scenes, or maybe recreate Bella's first tour of the house. After you finish building, each level can be removed to reveal all the rooms, accessories and functions inside.

From the first floor entrance, you can access Carlisle's study or let Bella and Edward enjoy a quiet moment at the grand piano.

Move upstairs to the living room and kitchen where the family is preparing a welcome meal fit for Bella.

Next, take the stairs past the graduation cap mural to Edward's sparsely furnished room to discuss music, vampires' sleep patterns (or rather the lack thereof) and, finally, top off your visit with a treetop view from the forest outside.



“Are those graduation caps?”

- Charlie Swan, *The Twilight Saga: Breaking Dawn - Part 1* (2011)

ore p
ua. Ut enim
am, quis nostrud e
ation ullamco labo
i ut aliquip ex ea
lo consequat. De
dolor in rep-
a voluptate velit
llum dolore eu f
e pariat. Excep



Faites le tour de la maison

Avec sept figurines LEGO®, vous pouvez aménager votre modèle pour exposer vos scènes préférées, ou peut-être recréer la première visite de la maison par Bella. Une fois la construction terminée, chaque étage peut être retiré pour révéler les pièces, les accessoires et les fonctions à l'intérieur.

Depuis l'entrée du rez-de-chaussée, vous pouvez accéder au bureau de Carlisle ou emmener Bella et Edward au piano à queue pour profiter d'un moment de tranquillité.

Montez à l'étage pour accéder au salon et à la cuisine, où la famille prépare un repas de bienvenue pour Bella.

Ensuite, empruntez les escaliers, passez devant la mosaïque de chapeaux de diplômés et entrez dans la chambre d'Edward pour discuter de musique, du sommeil des vampires (ou plutôt de son inexistence) et, enfin, terminez votre visite par une vue de la cime des arbres depuis la forêt à l'extérieur.

« Ce sont des chapeaux de diplômés ? »

- Charlie Swan, *La saga Twilight : Révélation, partie 1* (2011)

Vamos a darte un recorrido

Con siete minifiguras LEGO® inspiradas en los personajes, puedes organizar tu modelo para mostrar tus escenas favoritas, o tal vez recrear el primer recorrido de Bella por la casa. Después de terminar la construcción, cada nivel se puede quitar para ver todas las habitaciones, accesorios y funciones del interior.

Desde la entrada del primer piso, puedes acceder al estudio de Carlisle o dejar que Bella y Edward disfruten de un momento tranquilo junto al piano de cola.

Sube al piso de arriba y visita la sala y la cocina, donde la familia está preparando una comida de bienvenida para Bella.

Luego, sube las escaleras junto al mural de los birretes de graduación hasta la habitación de Edward, escasamente amueblada, para hablar de música, los patrones de sueño de los vampiros (o la falta de ellos) y, finalmente, acaba la visita con una vista desde las copas de los árboles del bosque exterior.

“¿Son birretes de graduación?”

- Charlie Swan, *Crepúsculo, la saga: Amanecer - Parte 1* (2011)

From the LEGO® Ideas Design Team

The first time we see the Cullen House in *Twilight* (2008), Bella has already met most of the intriguing family at her new school, but this visit is her first proper introduction. Our team enjoyed working on this model immensely, both as fans ourselves, and because the Cullen House is a beautiful example of modern residential architecture. Our goal was to capture both the signature references and the characteristic architecture seen

mainly in the first movie. LEGO® Ideas fan designer Nick Micheels' passion for *The Twilight Saga* shines through in his original submission and the final model. The angles are clean, the builds are satisfying to put together, it's full of fun details and it looks great! We even included a few tributes to Nick, and to the author of the *Twilight* book series, Stephenie Meyer.

Un mot de l'équipe de conception LEGO® Ideas

La première fois que nous voyons la maison Cullen dans *Twilight : La fascination* (2008), Bella fait plus ample connaissance avec l'intrigante famille, dont elle a déjà rencontré plusieurs membres dans sa nouvelle école. Nous avons pris beaucoup de plaisir à travailler sur ce modèle, tant parce que nous sommes nous-mêmes des amateurs que parce que la maison Cullen est un magnifique exemple d'architecture résidentielle moderne. Notre objectif était de saisir à la fois les références et l'architecture caractéristique

que l'on voit principalement dans le premier film. La passion du concepteur amateur LEGO® Ideas Nick Micheels pour *Twilight* transparaît dans sa proposition originale et dans le modèle final. Les angles sont nets, les constructions sont agréables à assembler, et ce modèle est plein de détails amusants et de charme ! Nous avons même inclus quelques hommages à Nick et à l'auteure de la série de livres *Twilight*, Stephenie Meyer.

Impresiones del equipo de diseño de LEGO® Ideas

La primera vez que vemos la Casa de los Cullen en *Crepúsculo* (2008), Bella ya ha conocido a la mayoría de la intrigante familia en su nueva escuela, pero esta visita es su primera presentación formal. Trabajar en este modelo fue algo que nuestro equipo disfrutó enormemente, tanto como fans como por la belleza de la Casa de los Cullen, que es un hermoso ejemplo de arquitectura residencial moderna. Nuestro objetivo era capturar tanto las referencias distintivas como la arquitectura característica

vista principalmente en la primera película. La pasión del fan diseñador de LEGO® Ideas Nick Micheels por *Crepúsculo, la saga* se refleja tanto en su propuesta original como en el modelo final. Los ángulos son precisos, las construcciones son satisfactorias de armar, está lleno de detalles divertidos, ¡y se ve increíble! También incluimos algunos homenajes a Nick y a la autora de la serie *Crepúsculo*, Stephenie Meyer.





...un dolor sit amet, con
bore et dolore magna aliqua. Ut enim
laboris nisi ut aliquip ex ea commodo conseq
...llum dolore eu fugiat nulla par
...da qui officia deserunt mollit anim
...ror sit voluptatem accusan
...at non pro
...perspiciatis



Itinciis et verum re natur,
in perpetuum!! Simis, totas
eosa pla volo di inciduail

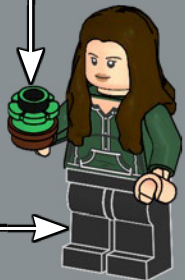
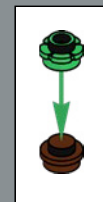
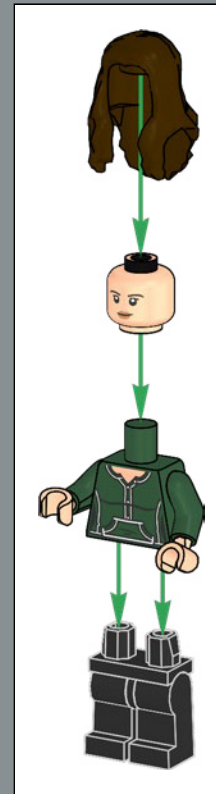
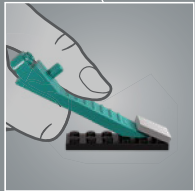
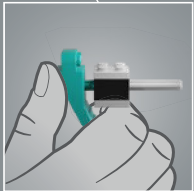
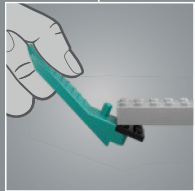
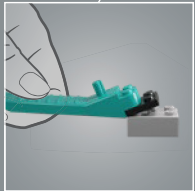
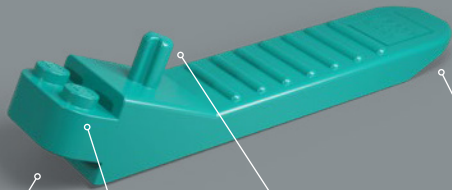

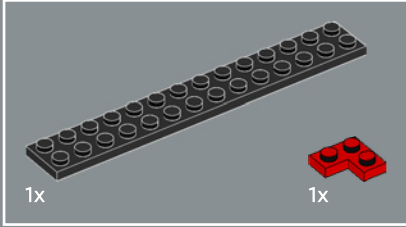
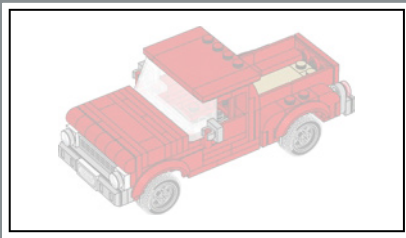

1

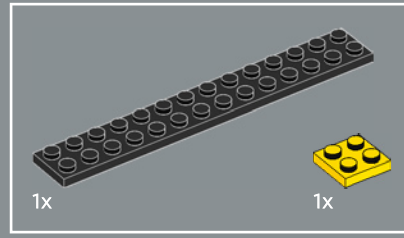
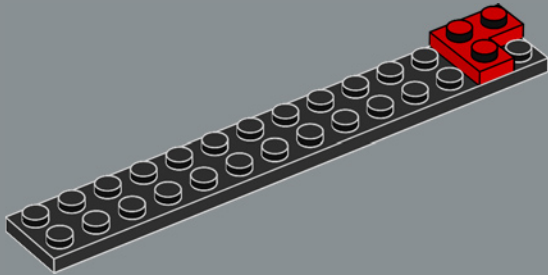

2

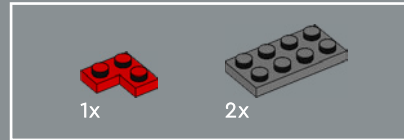
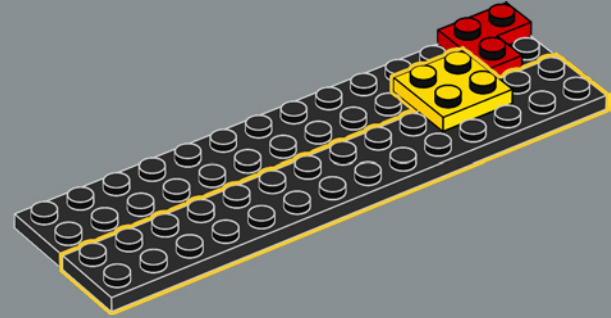

3

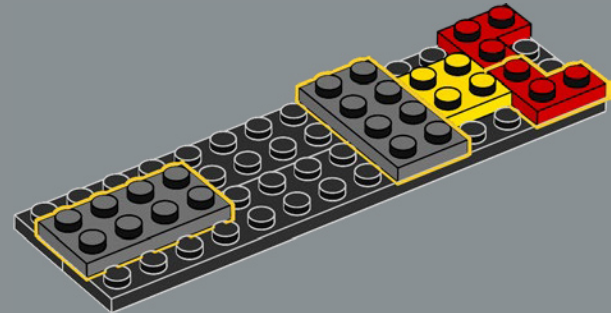

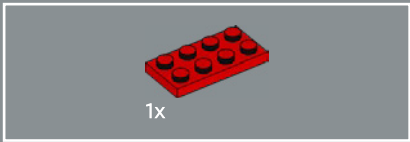

4

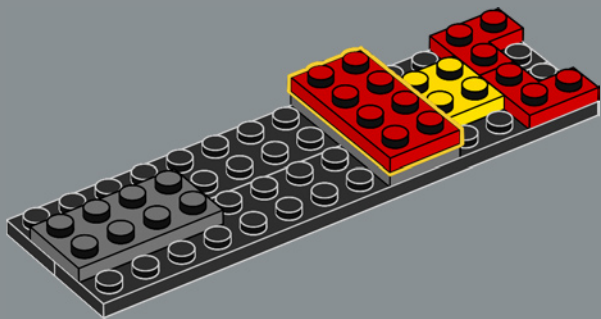

5

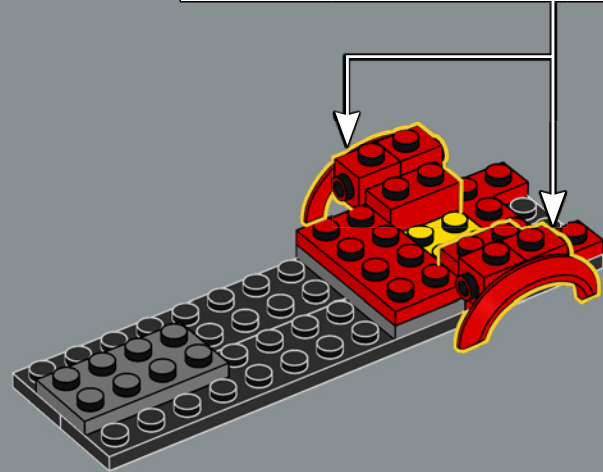
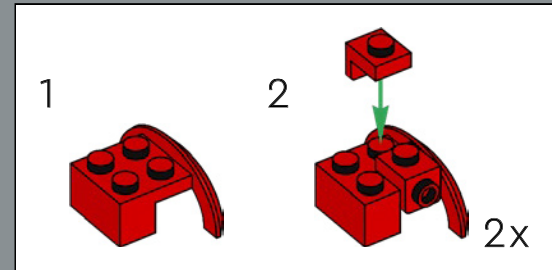

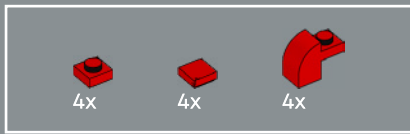

6

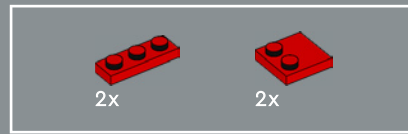
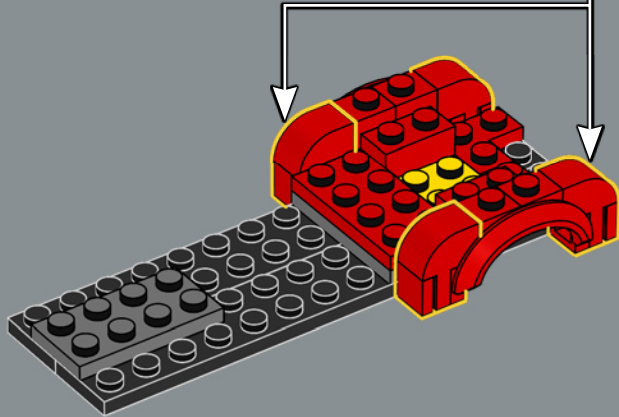
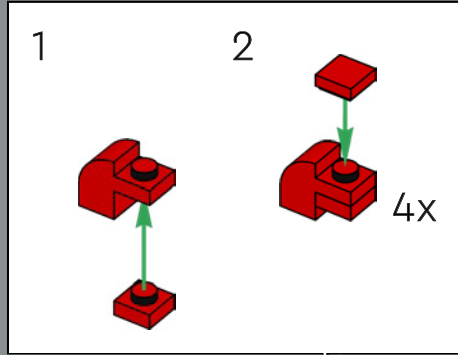

7

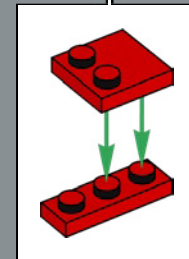
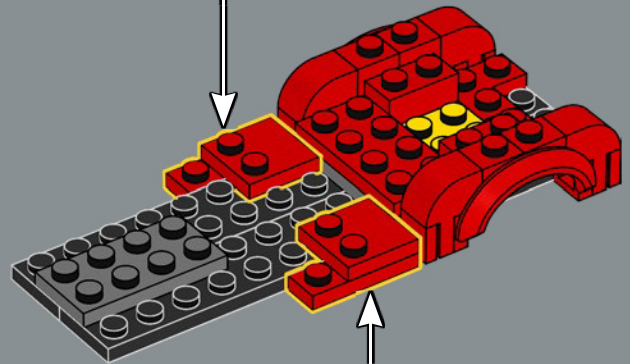
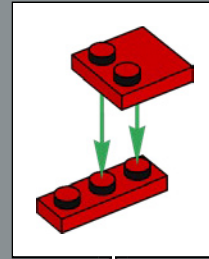

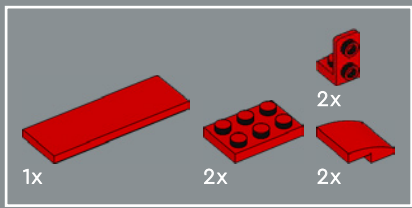

8



1

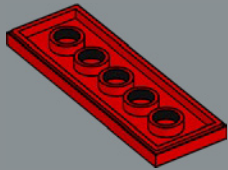

2

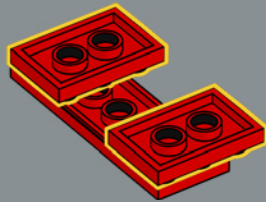

3

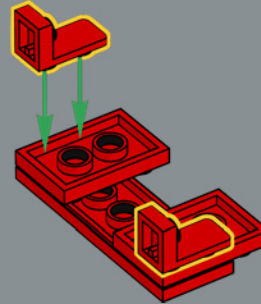

4

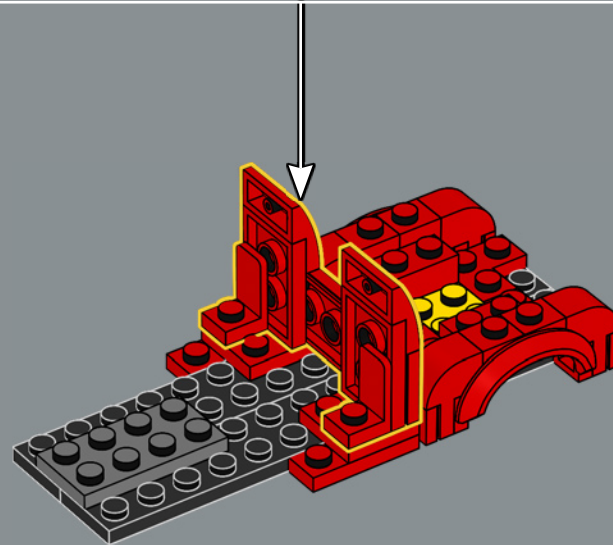
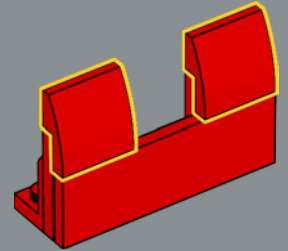

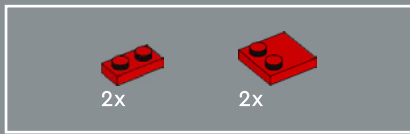

9

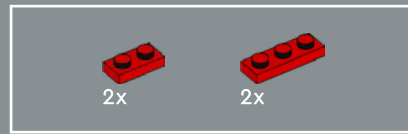
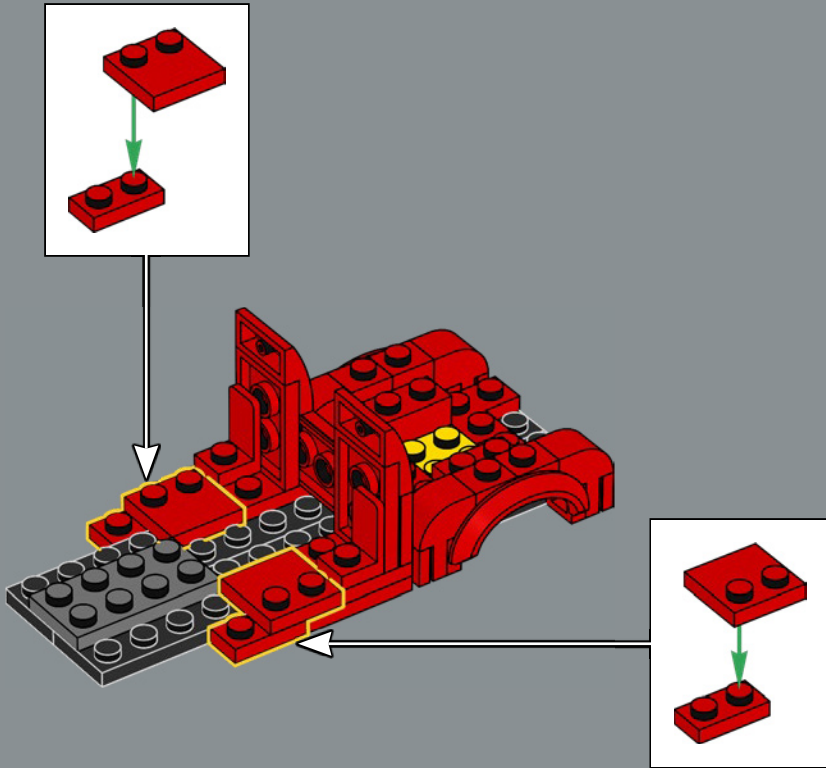

10

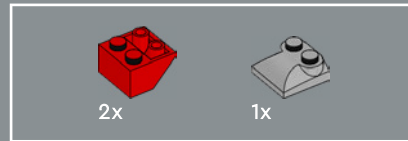
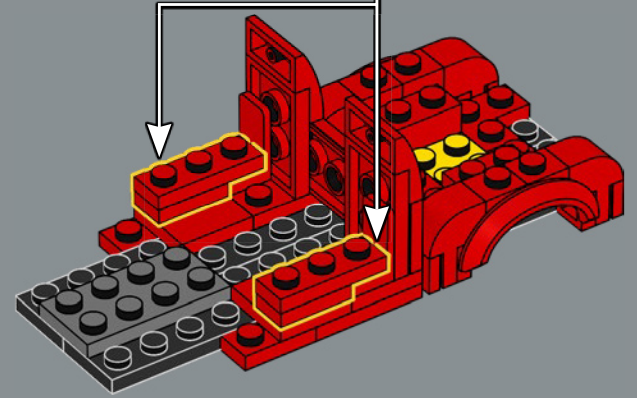
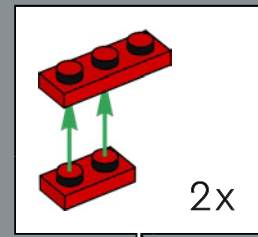

11

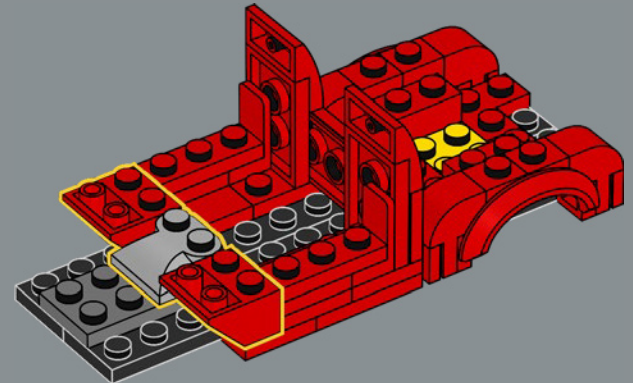



2x

12

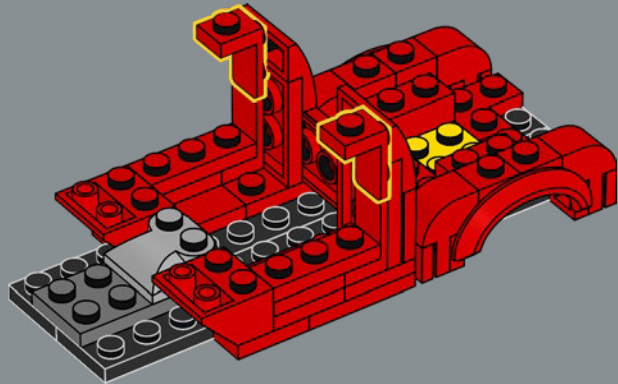

1x

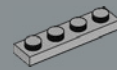

1x



1x

14

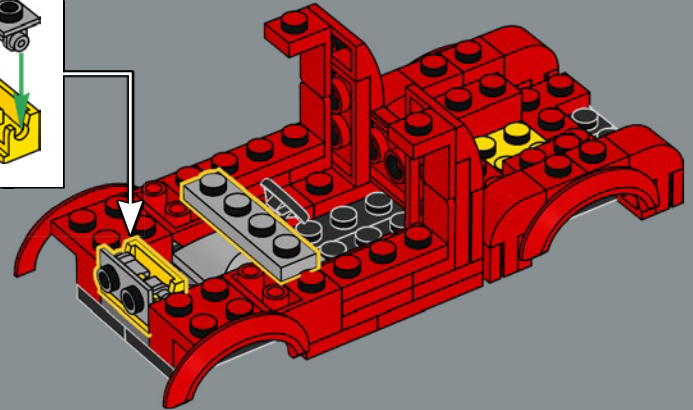
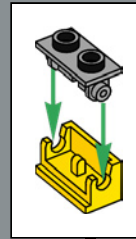

1x



2x

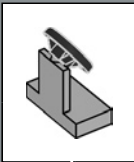

13

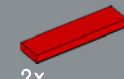
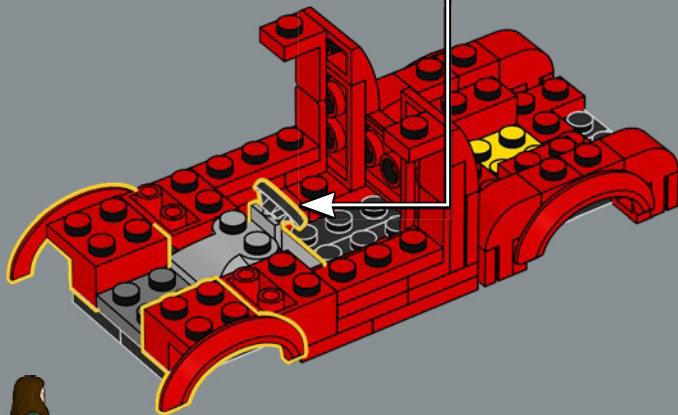

2x



2x



2x

15

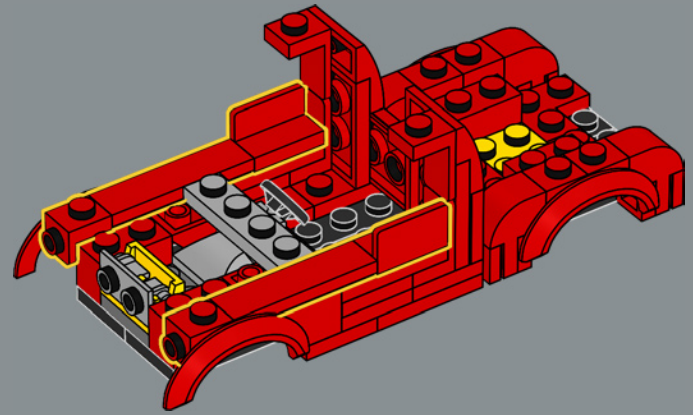

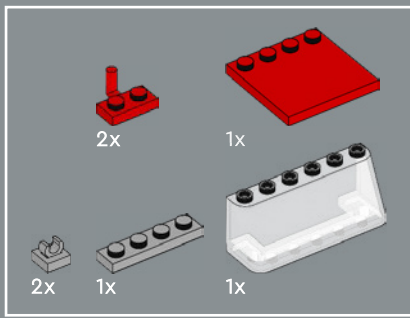

16

1

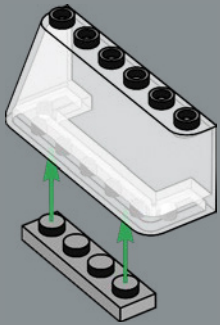

2

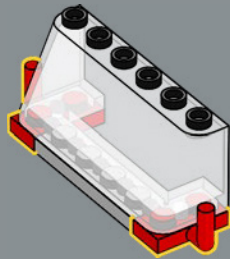

3

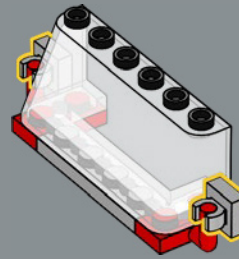

4

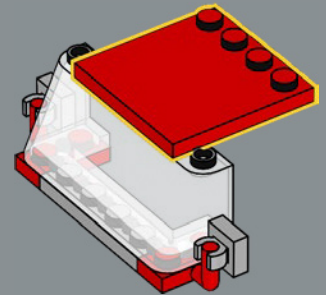

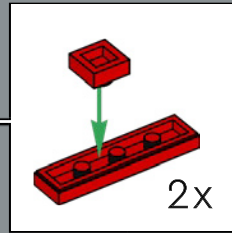
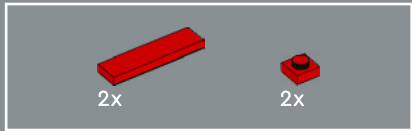
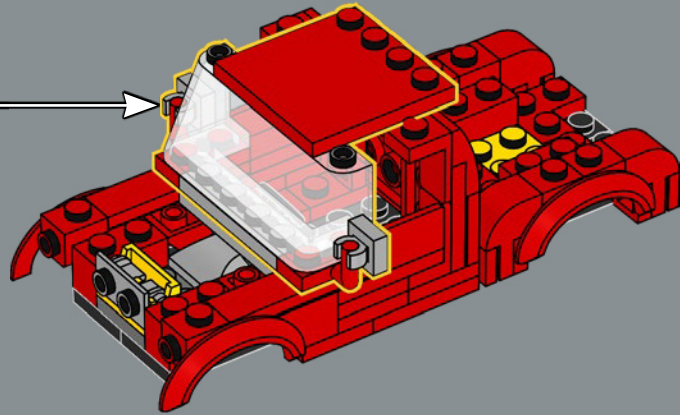

17

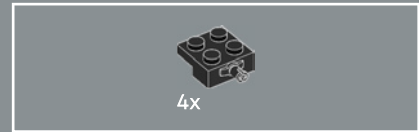
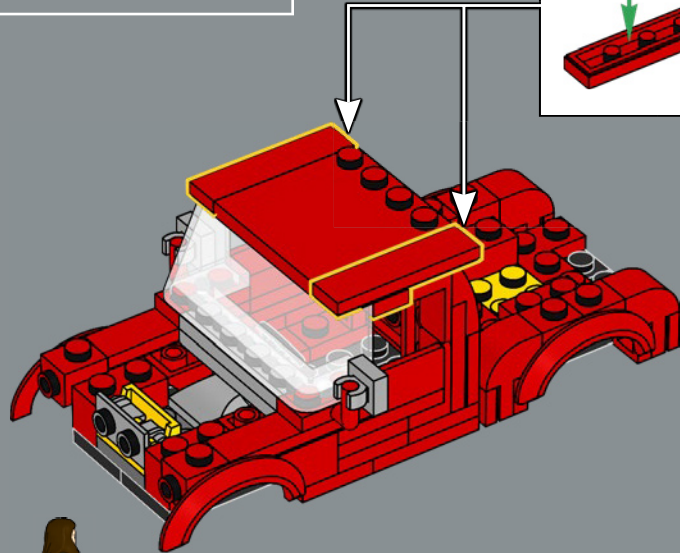

18

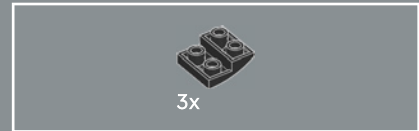
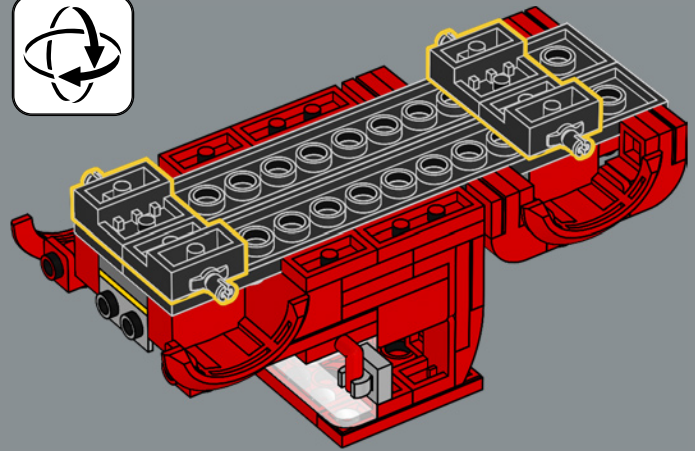

19

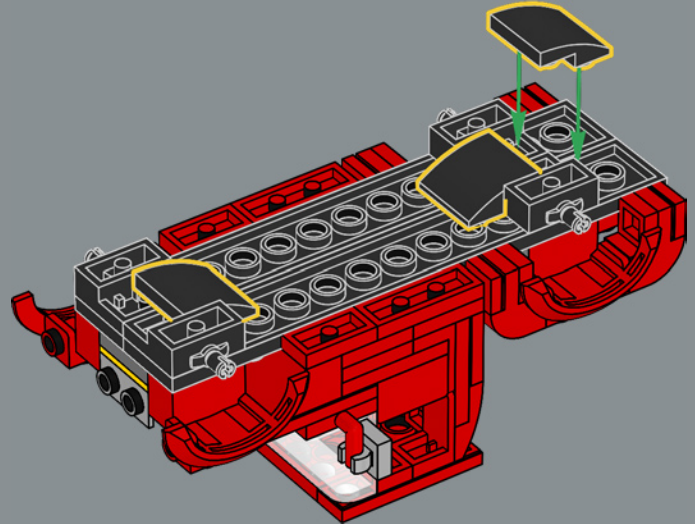

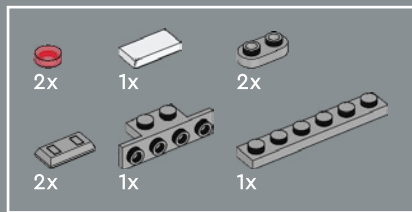

20

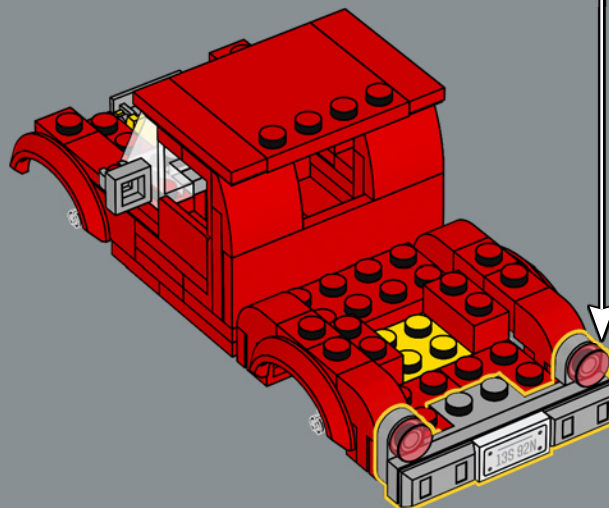
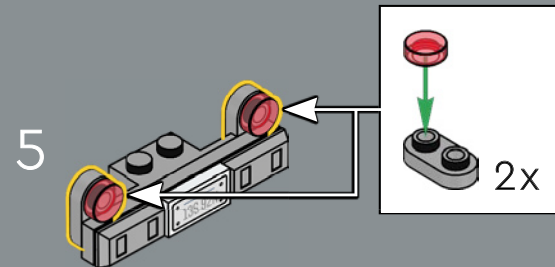
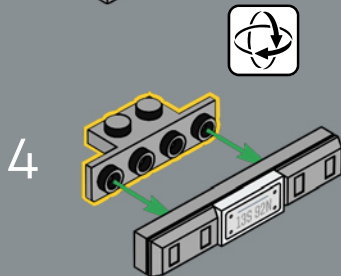
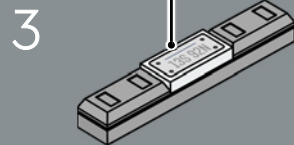
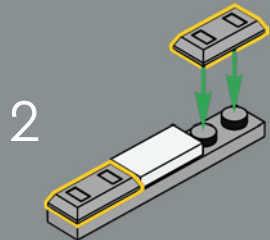
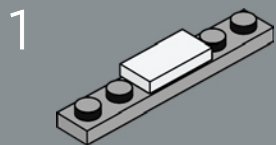



21

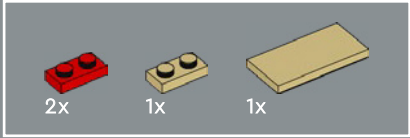
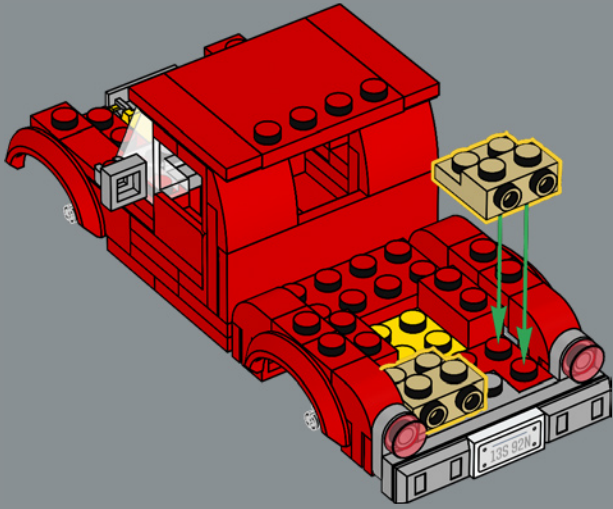

22

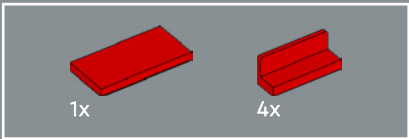
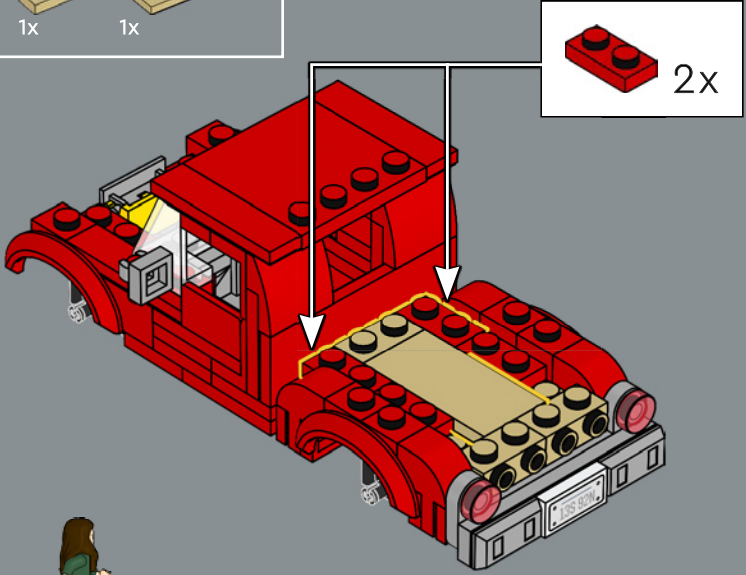

23

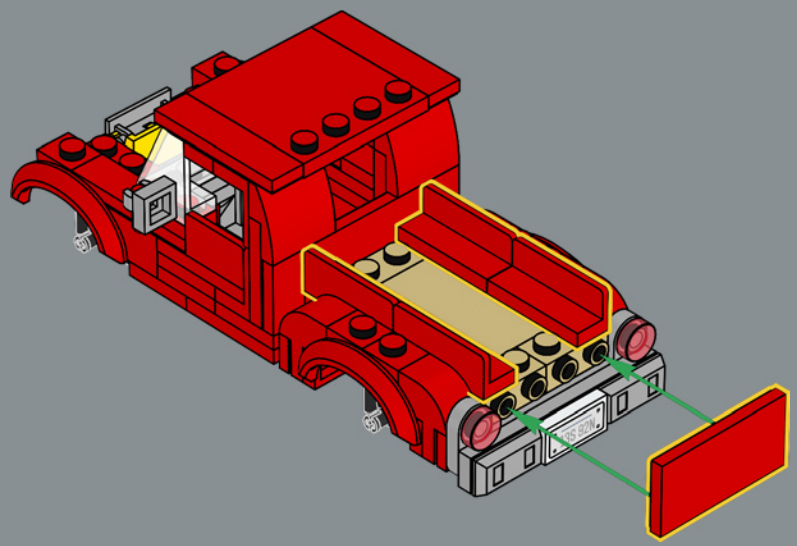

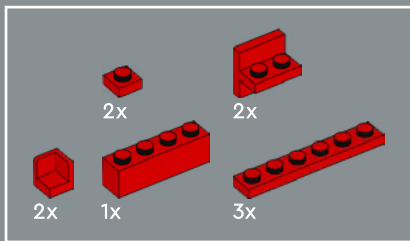

24

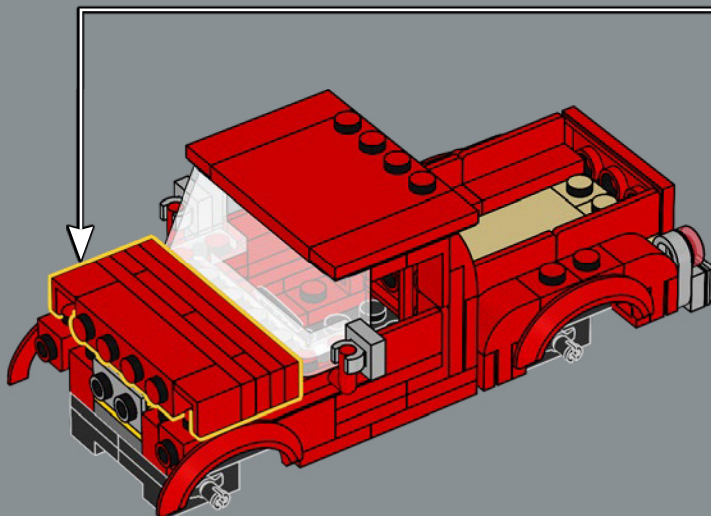
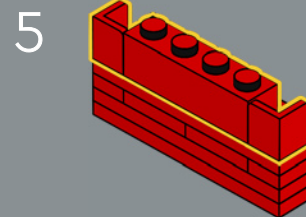
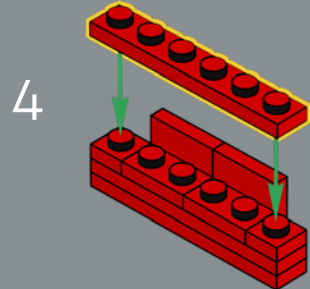
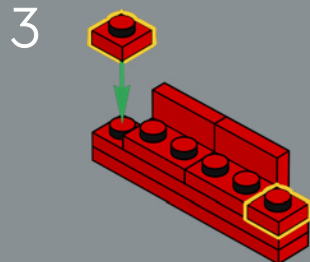
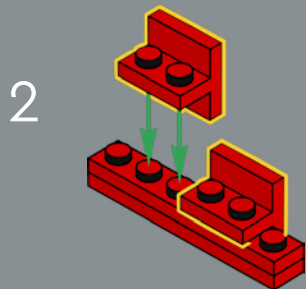
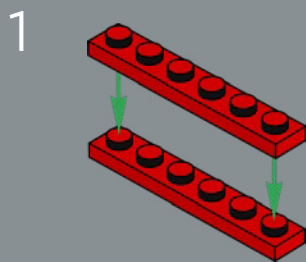

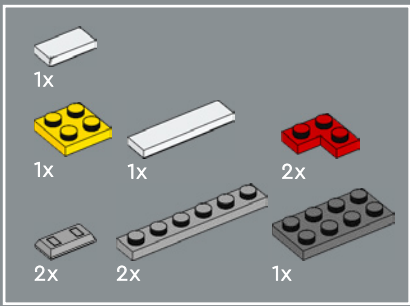

25

1

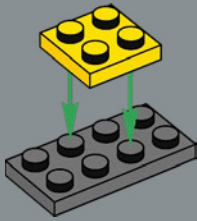

2

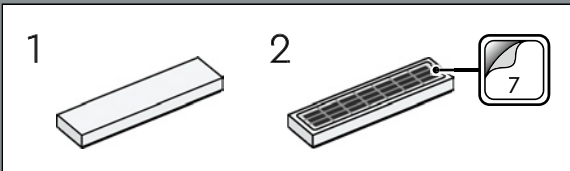
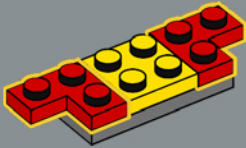

3

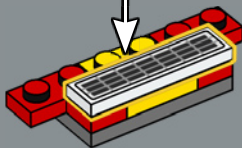

4

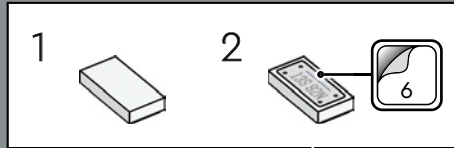
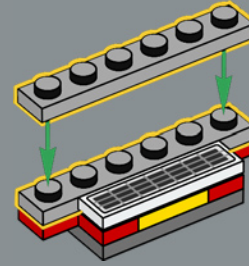

5

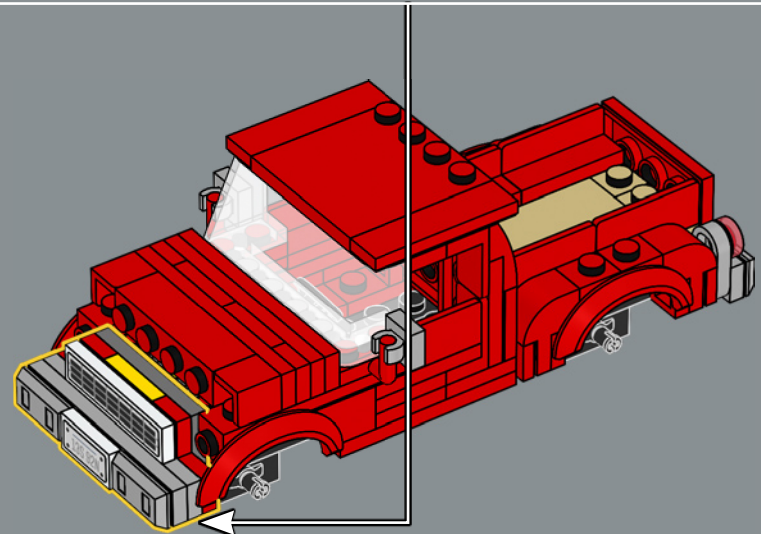
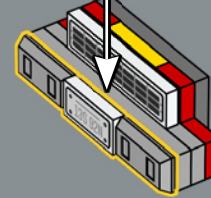

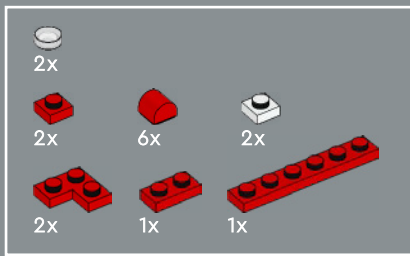

26

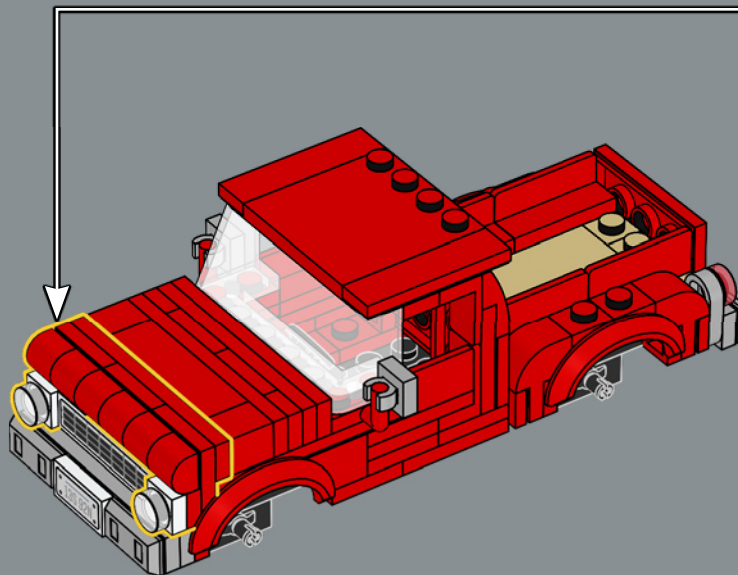
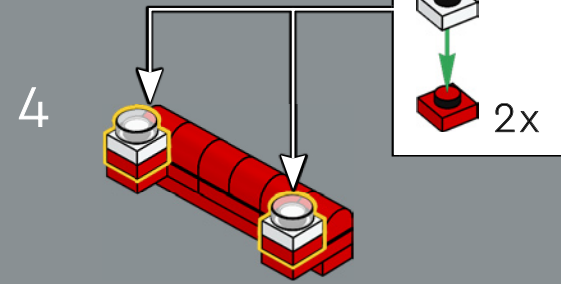
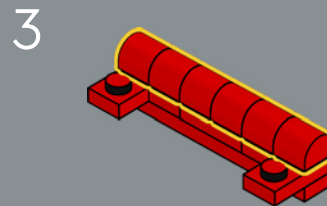
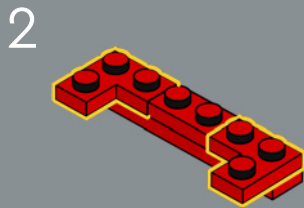
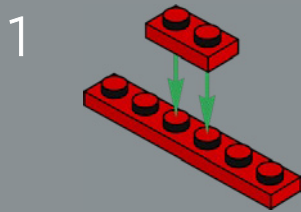



27

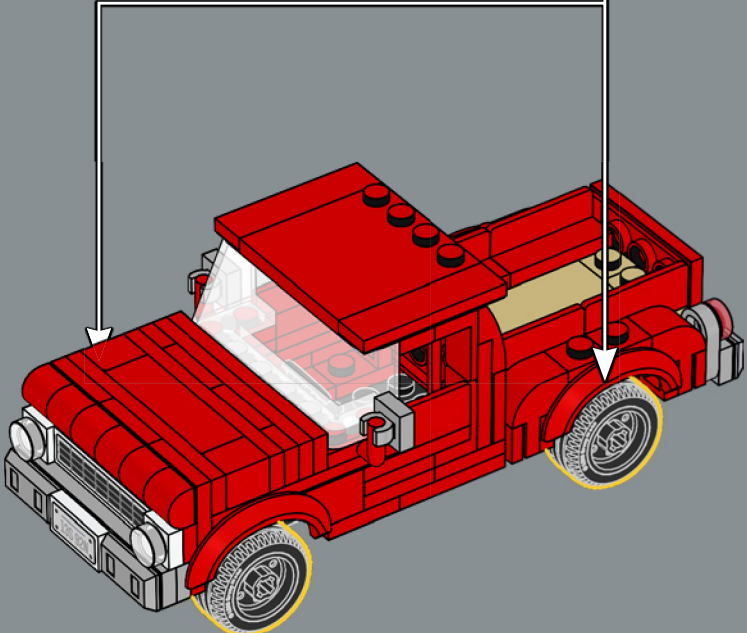
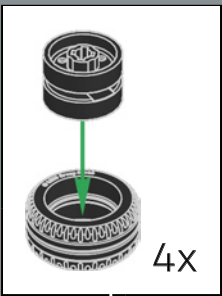

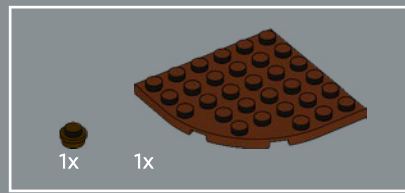

1

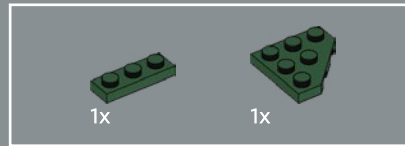
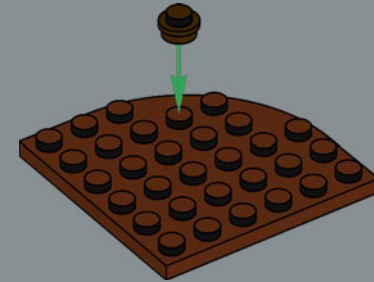

2

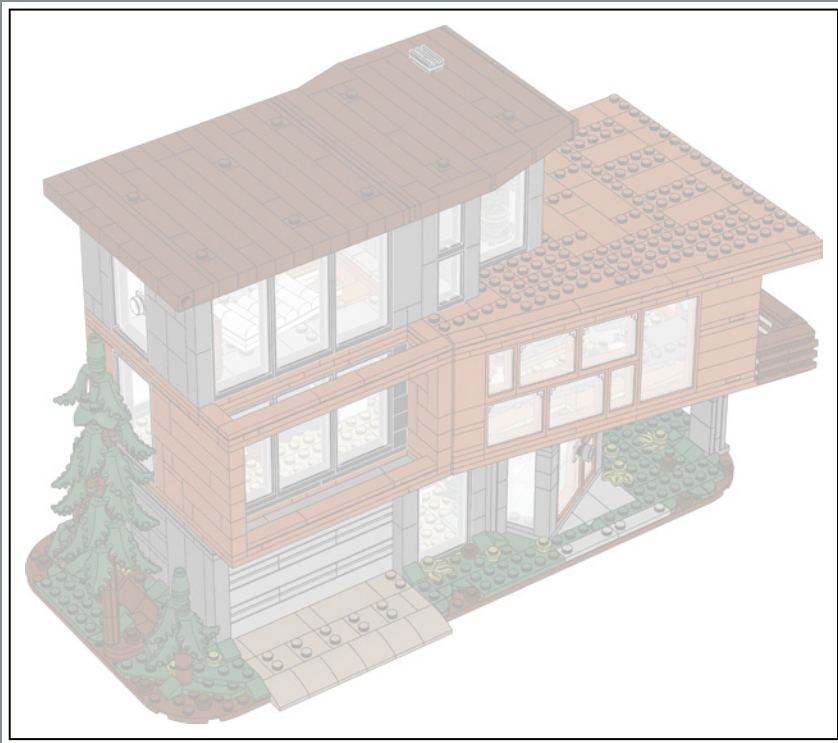
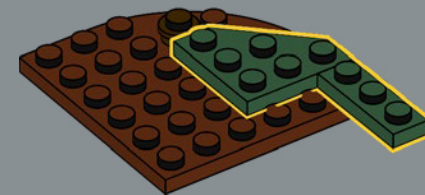

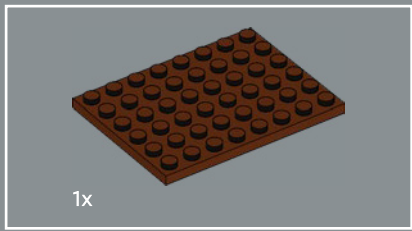

3

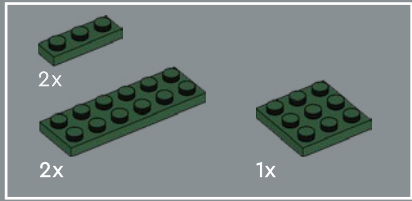
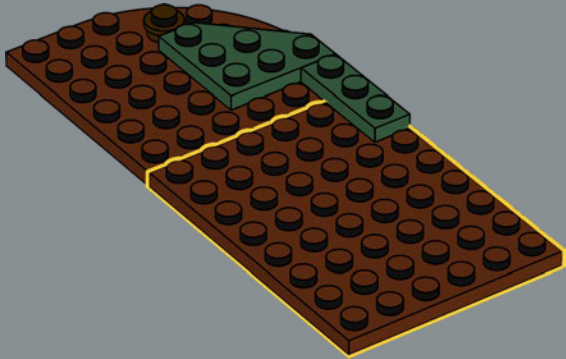

4

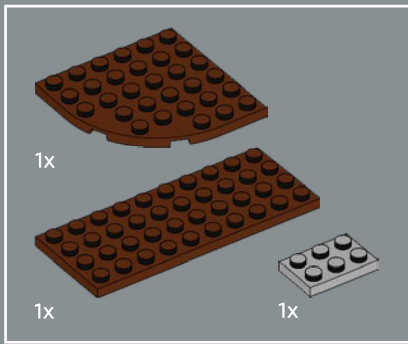
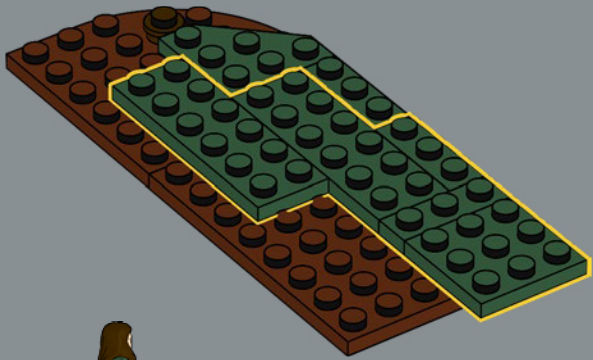

5

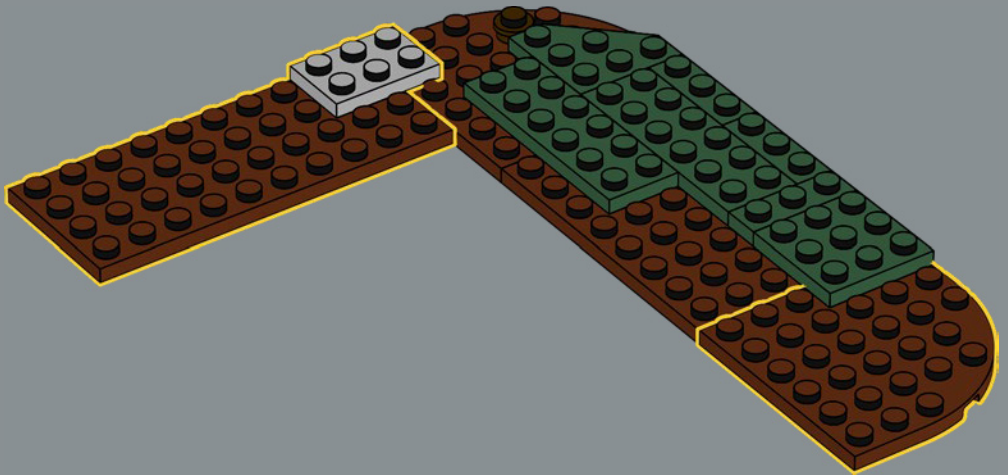

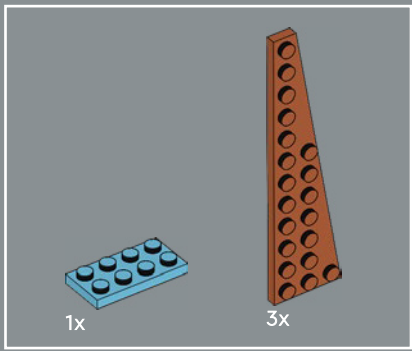

8

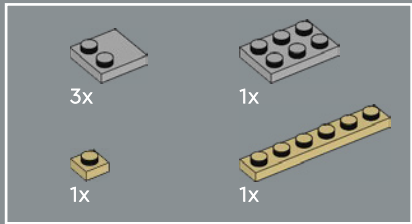
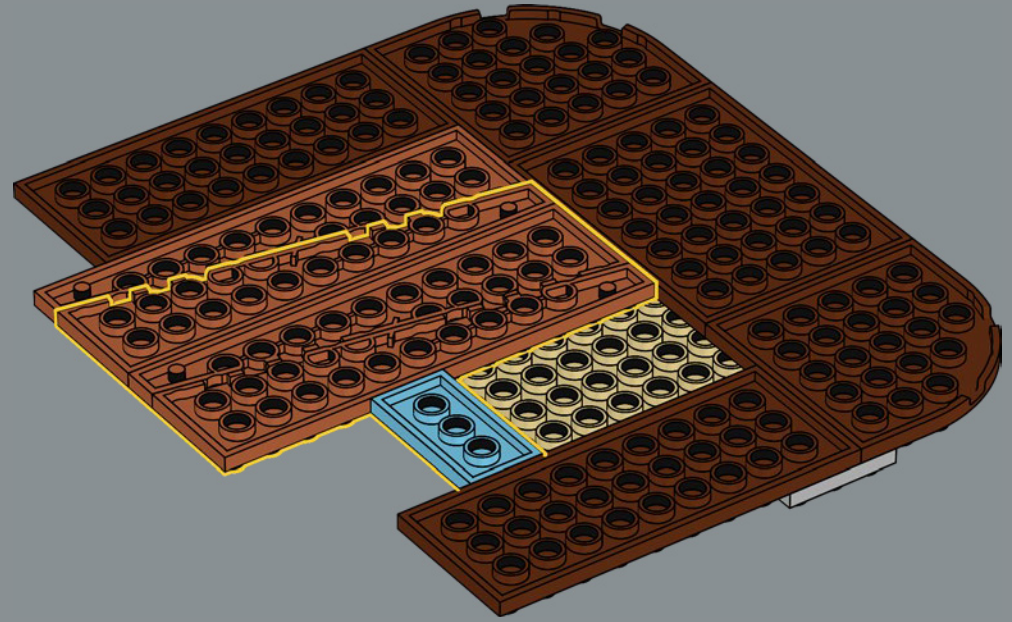

9

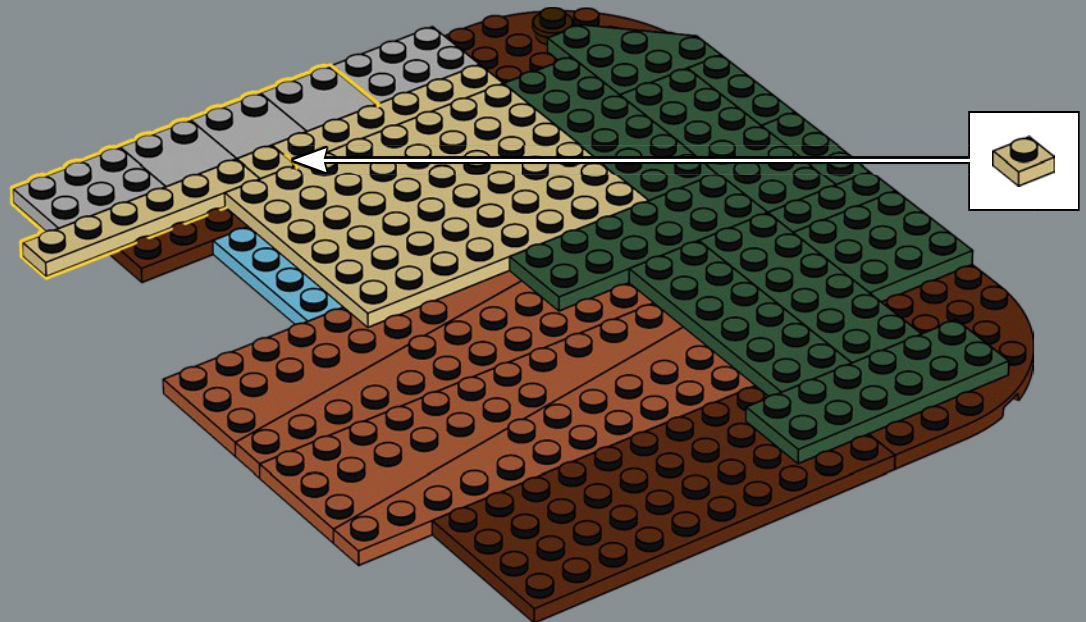

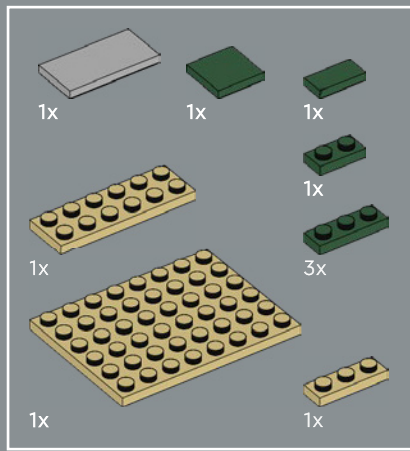

10

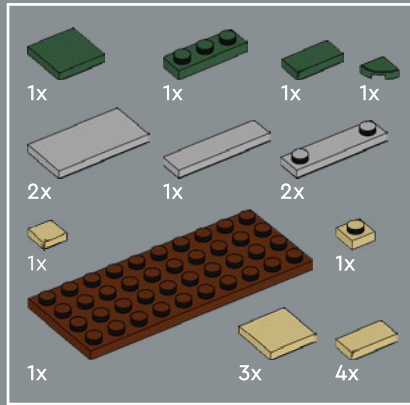
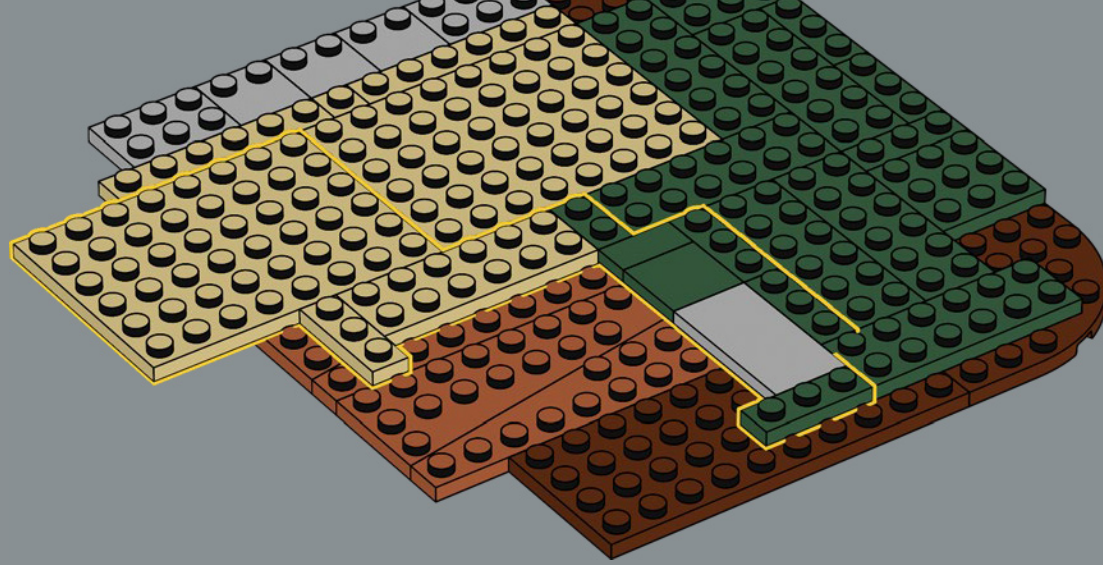

11

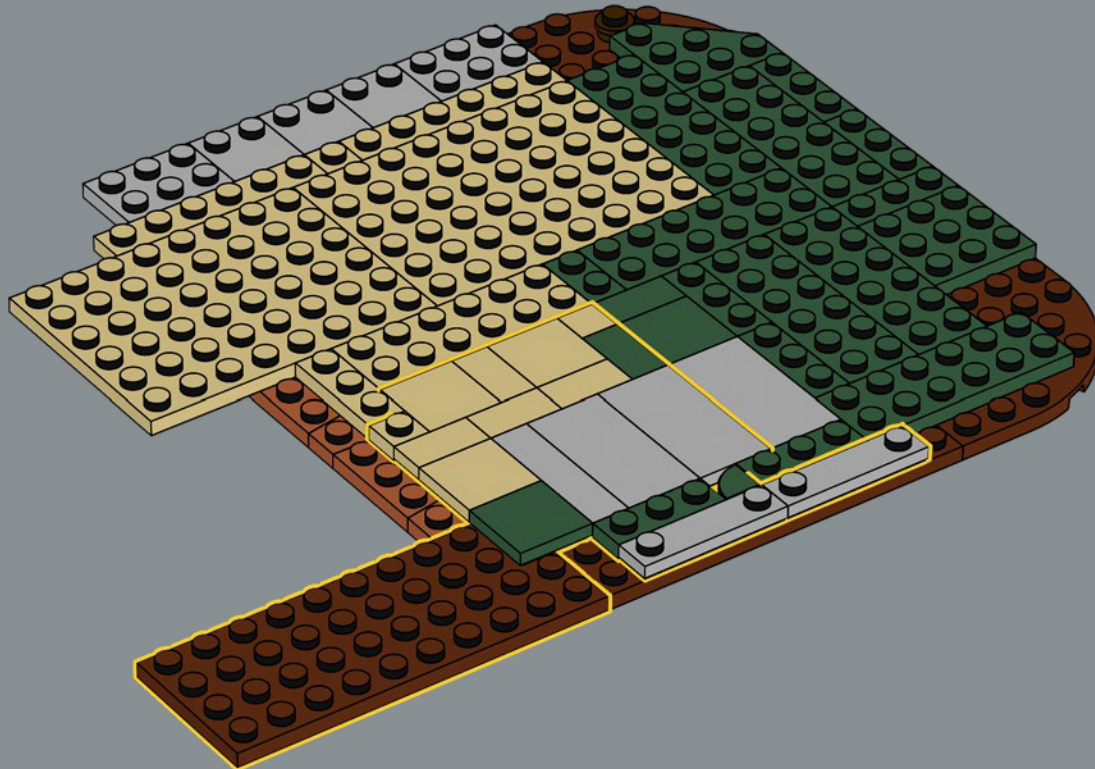

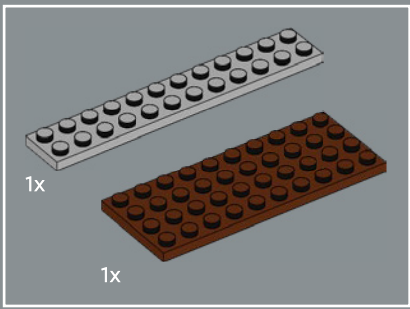

12

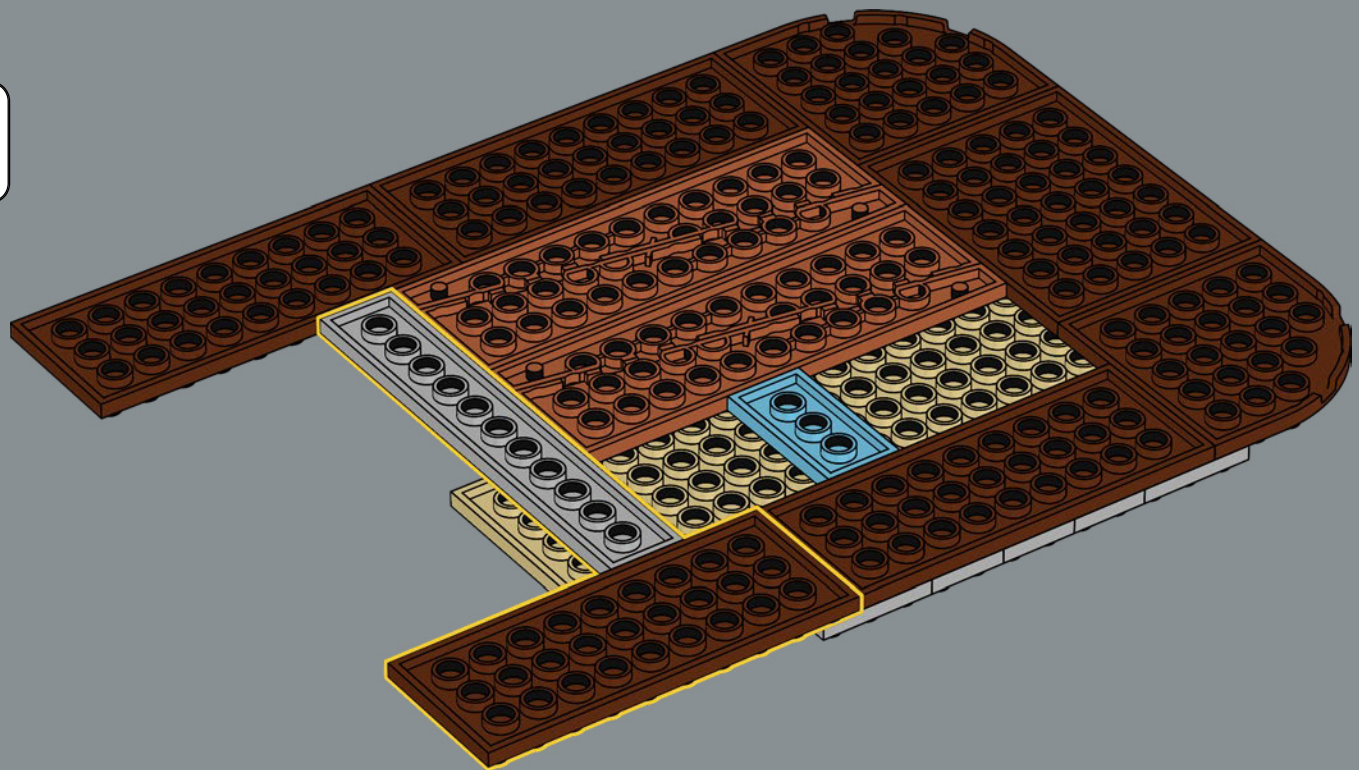

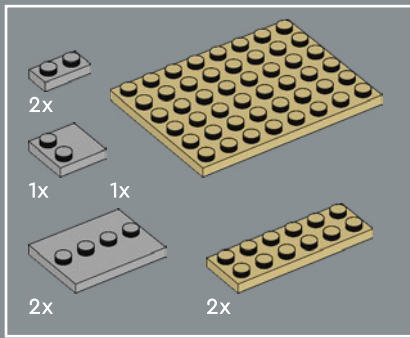

13

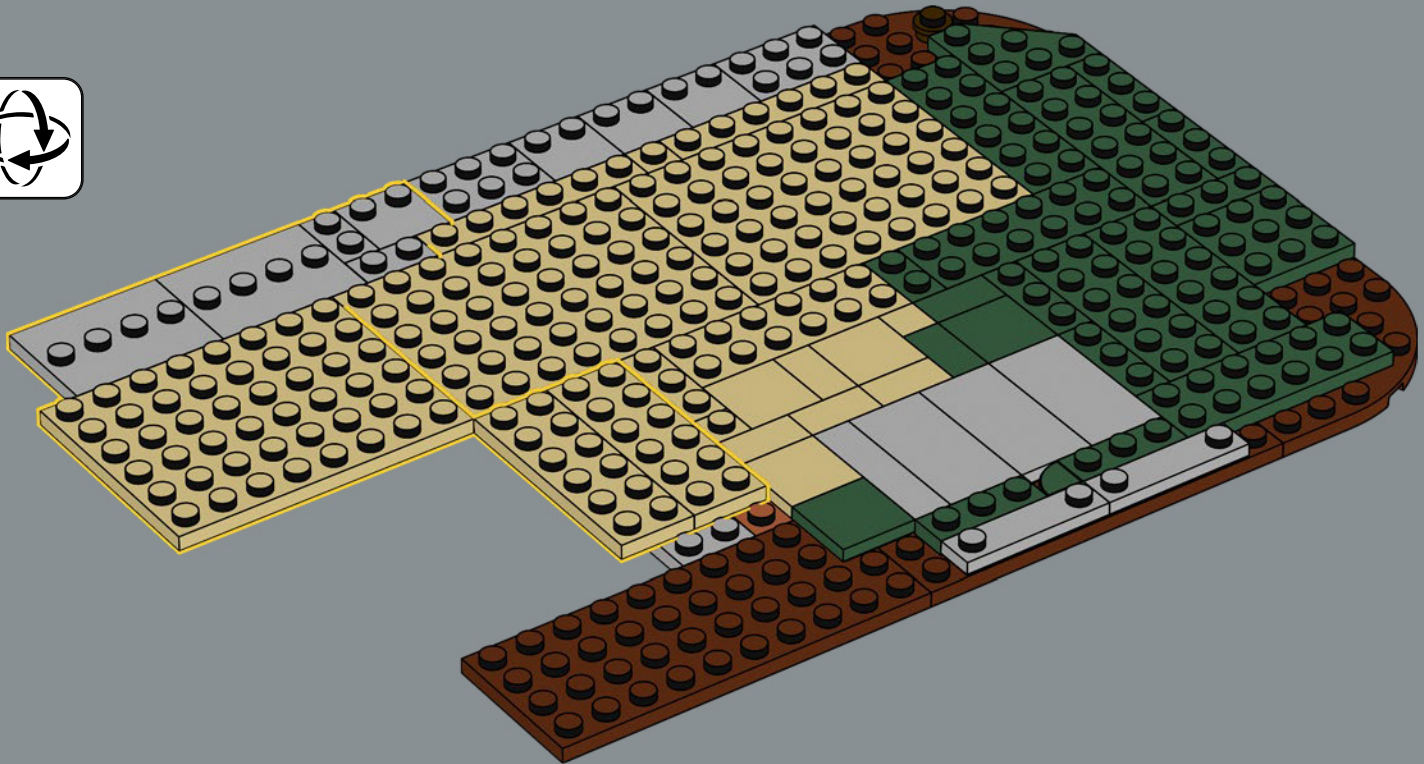

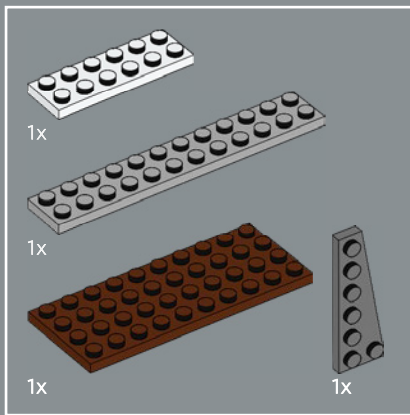

15

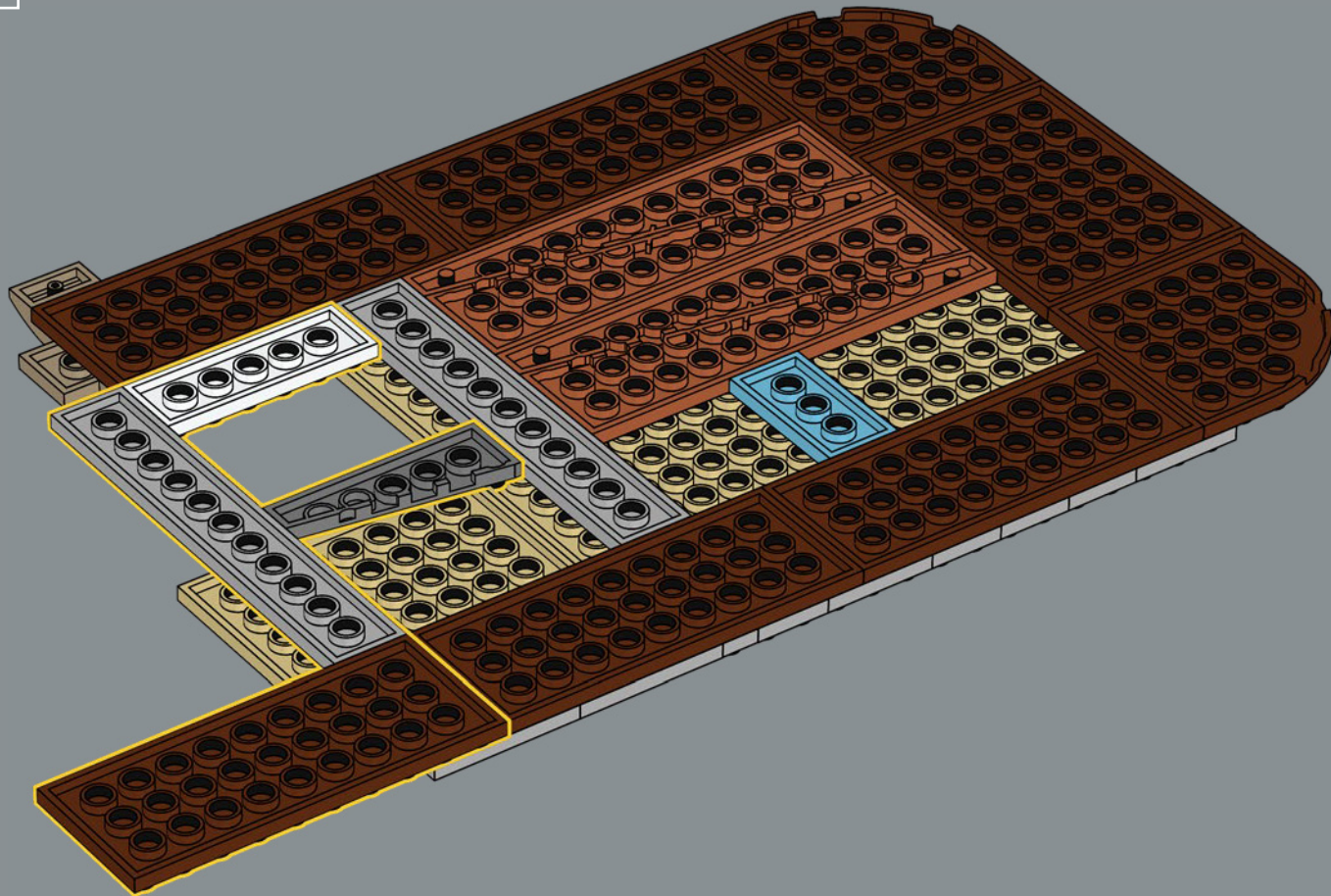

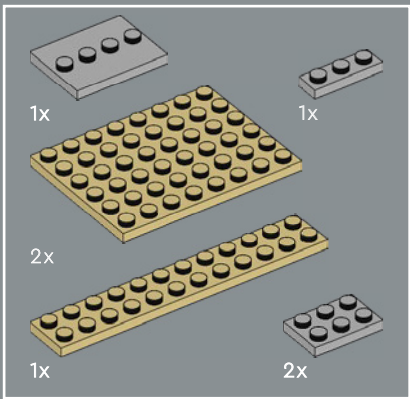

16

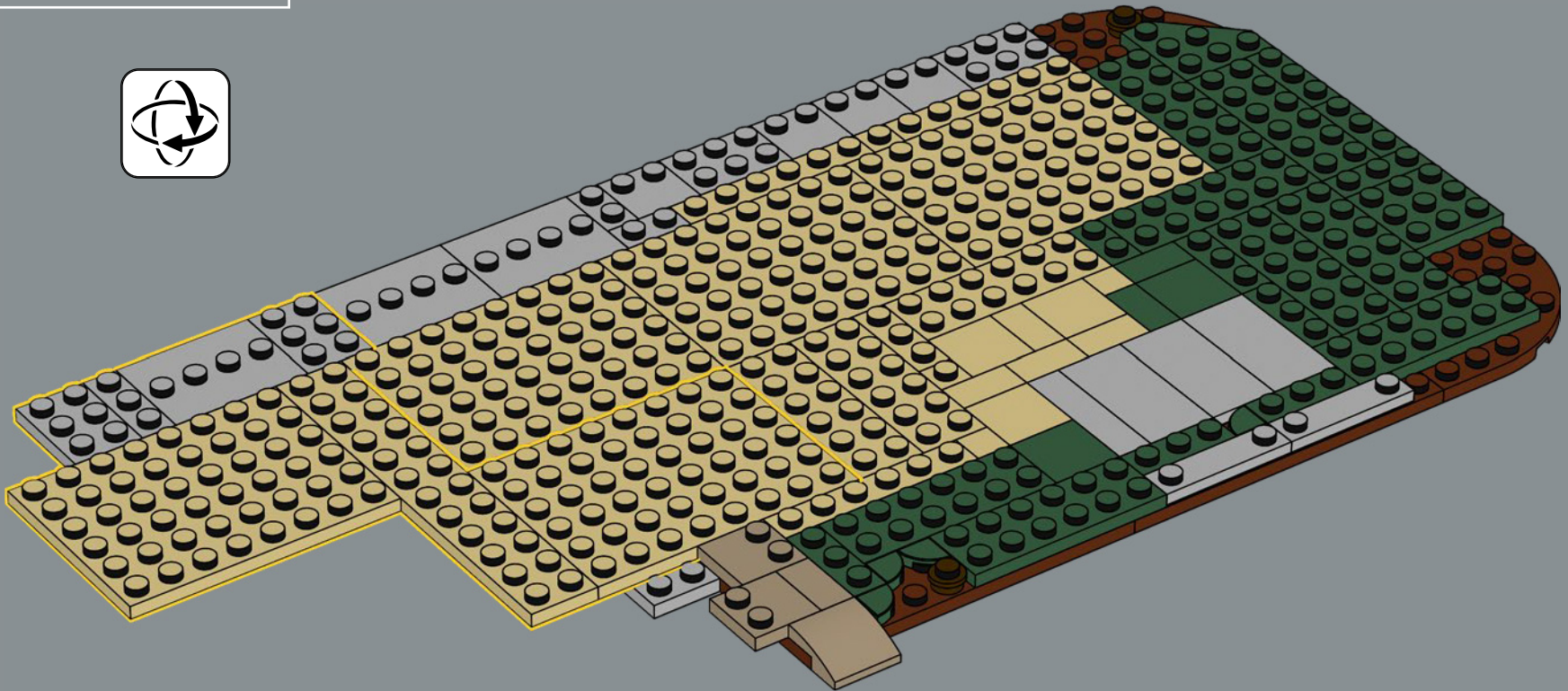

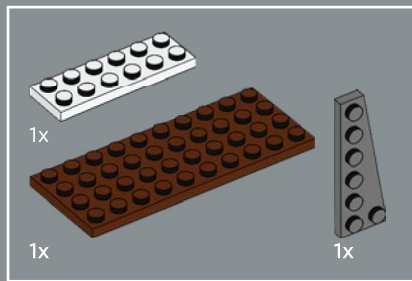

17

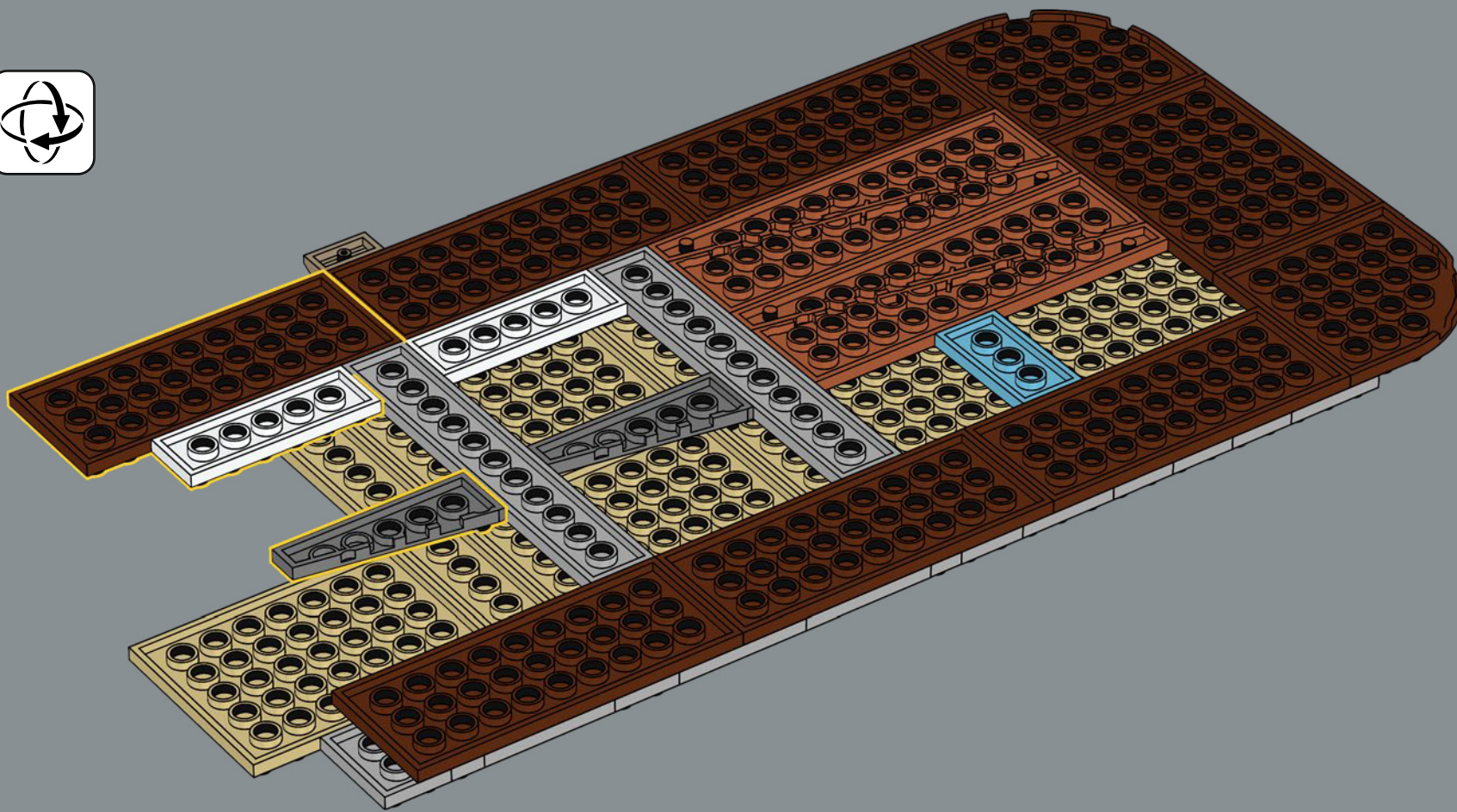

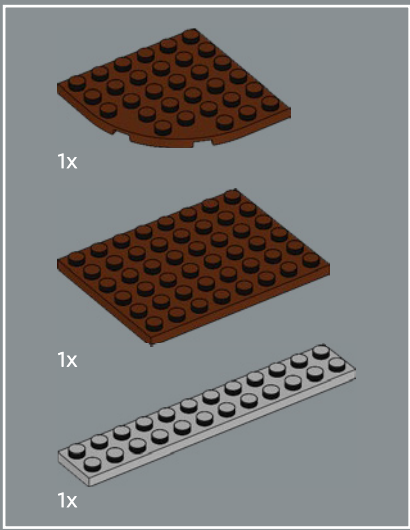

18

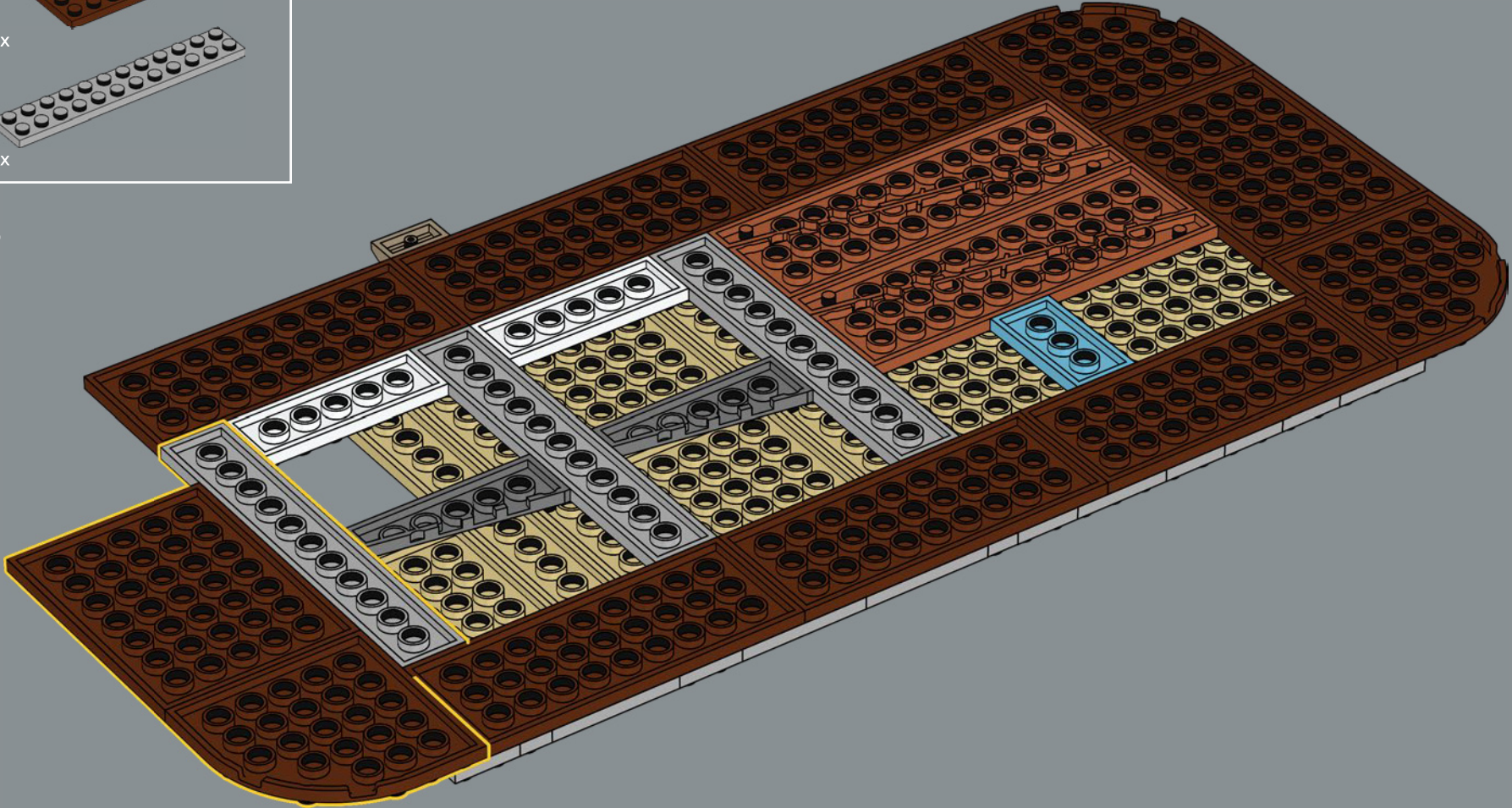

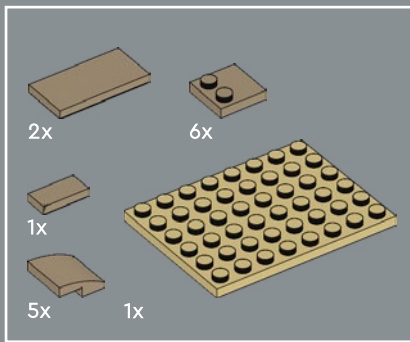

19

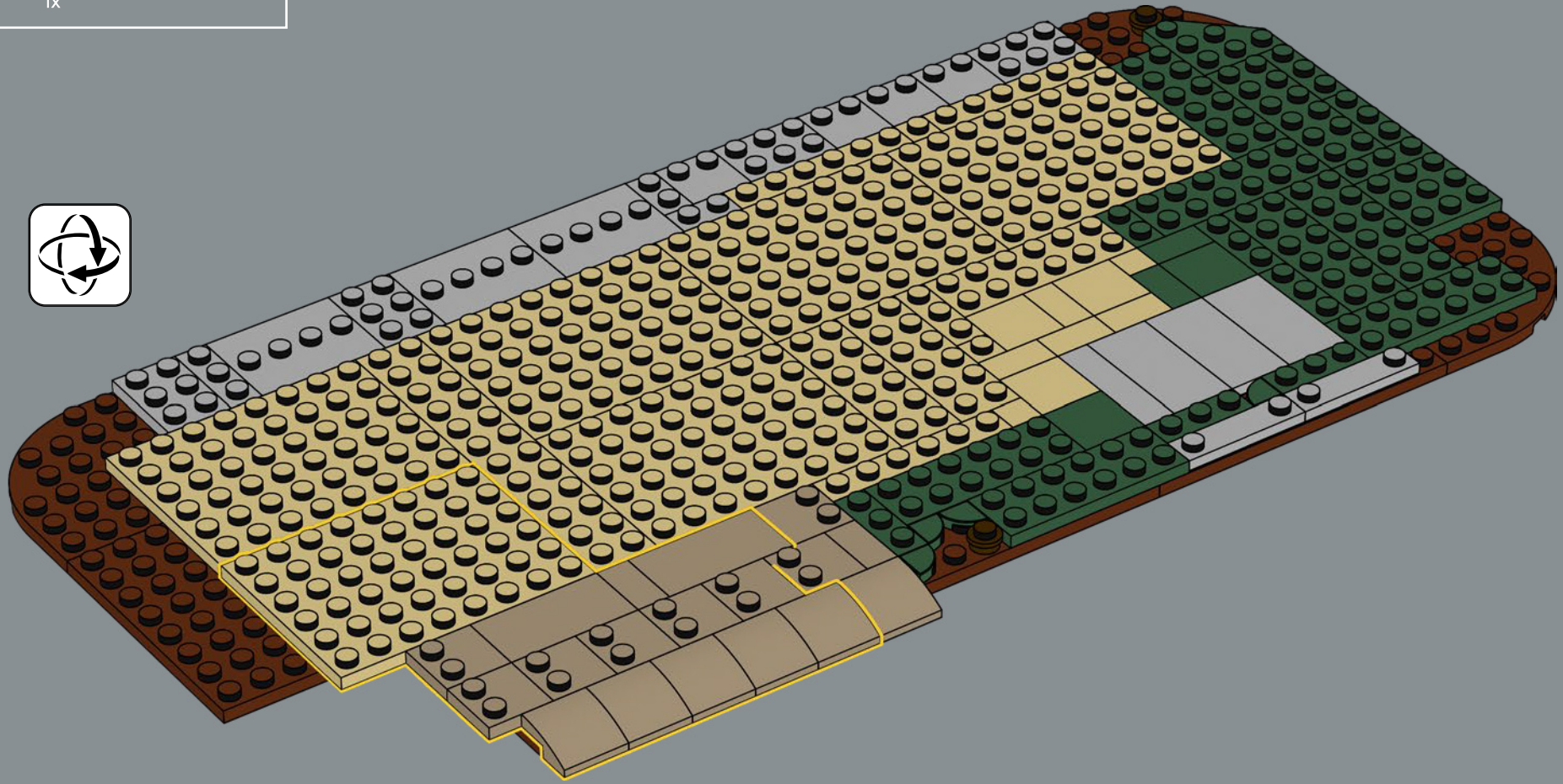

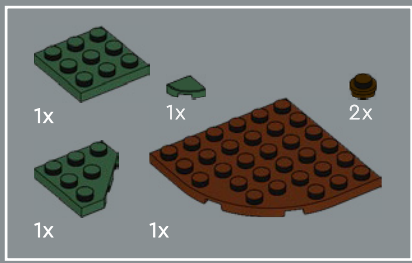

20

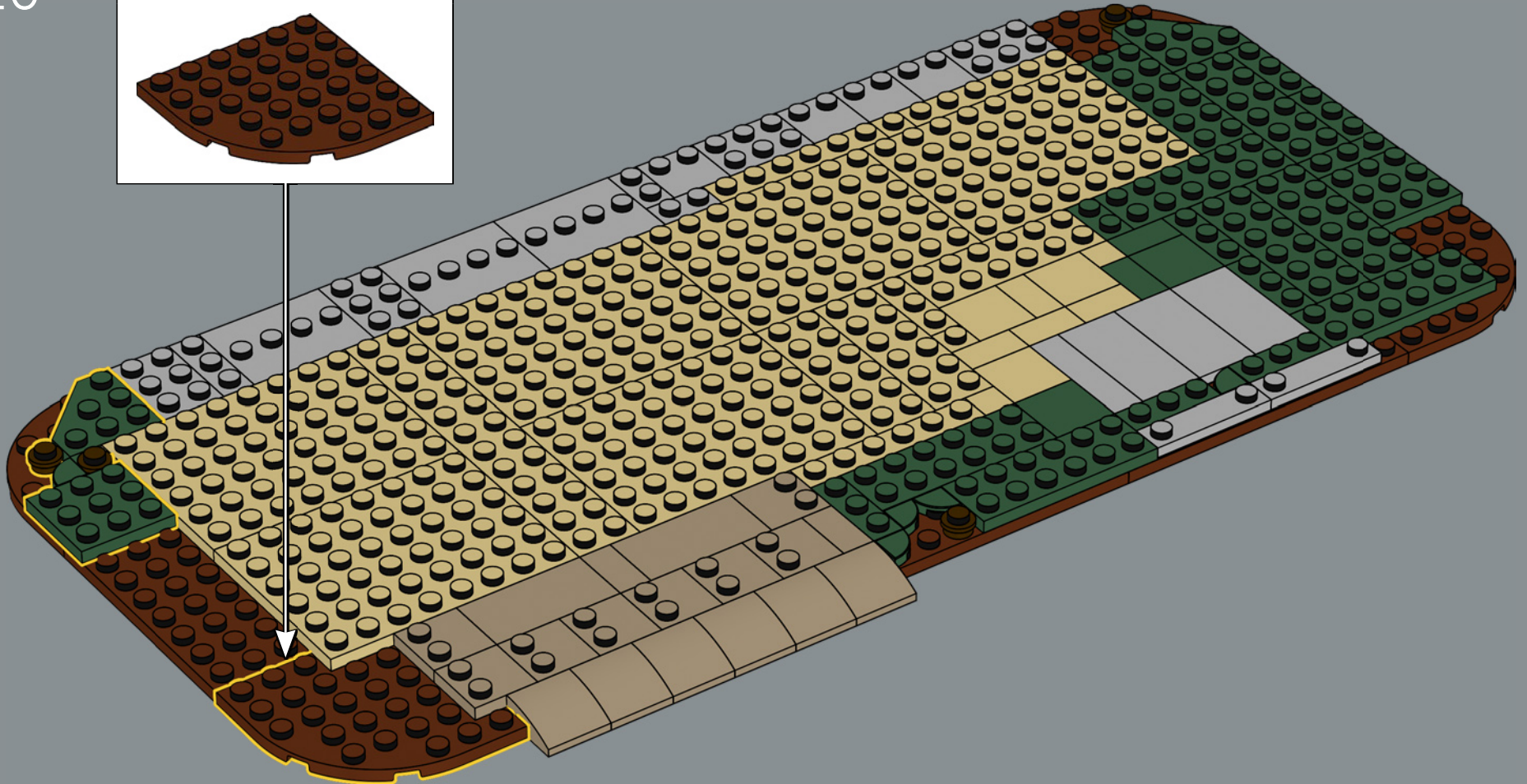
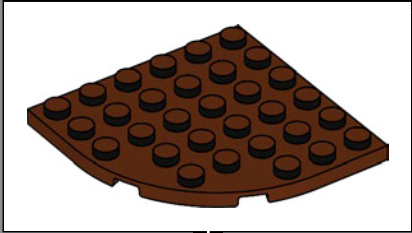

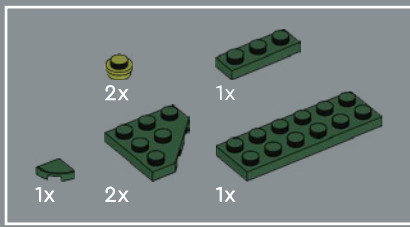

21

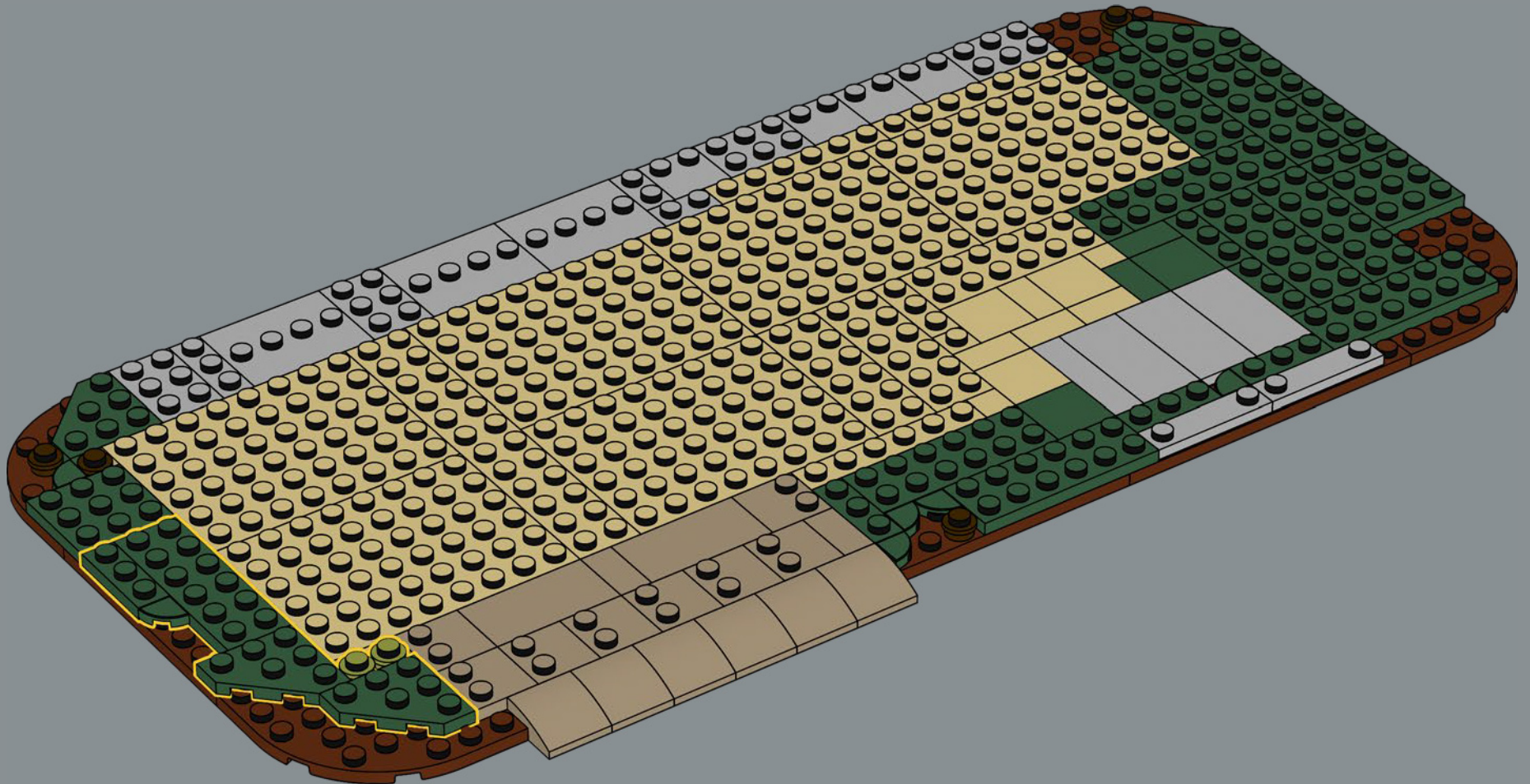

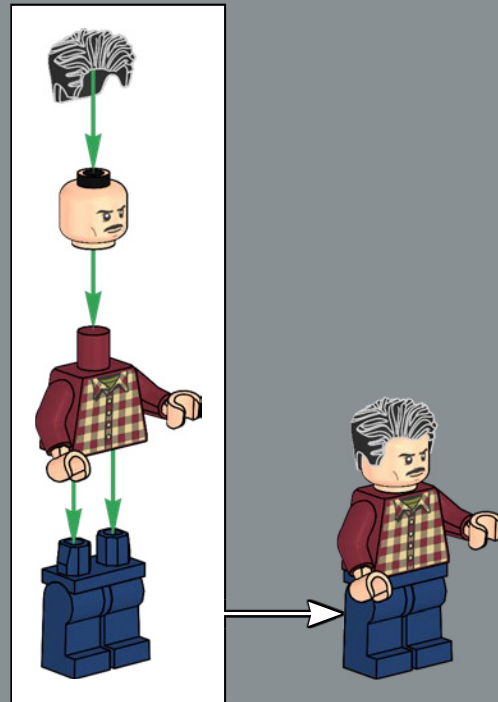

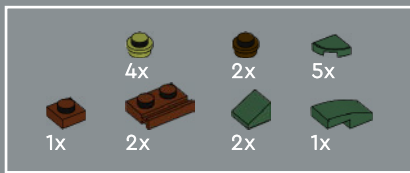

22

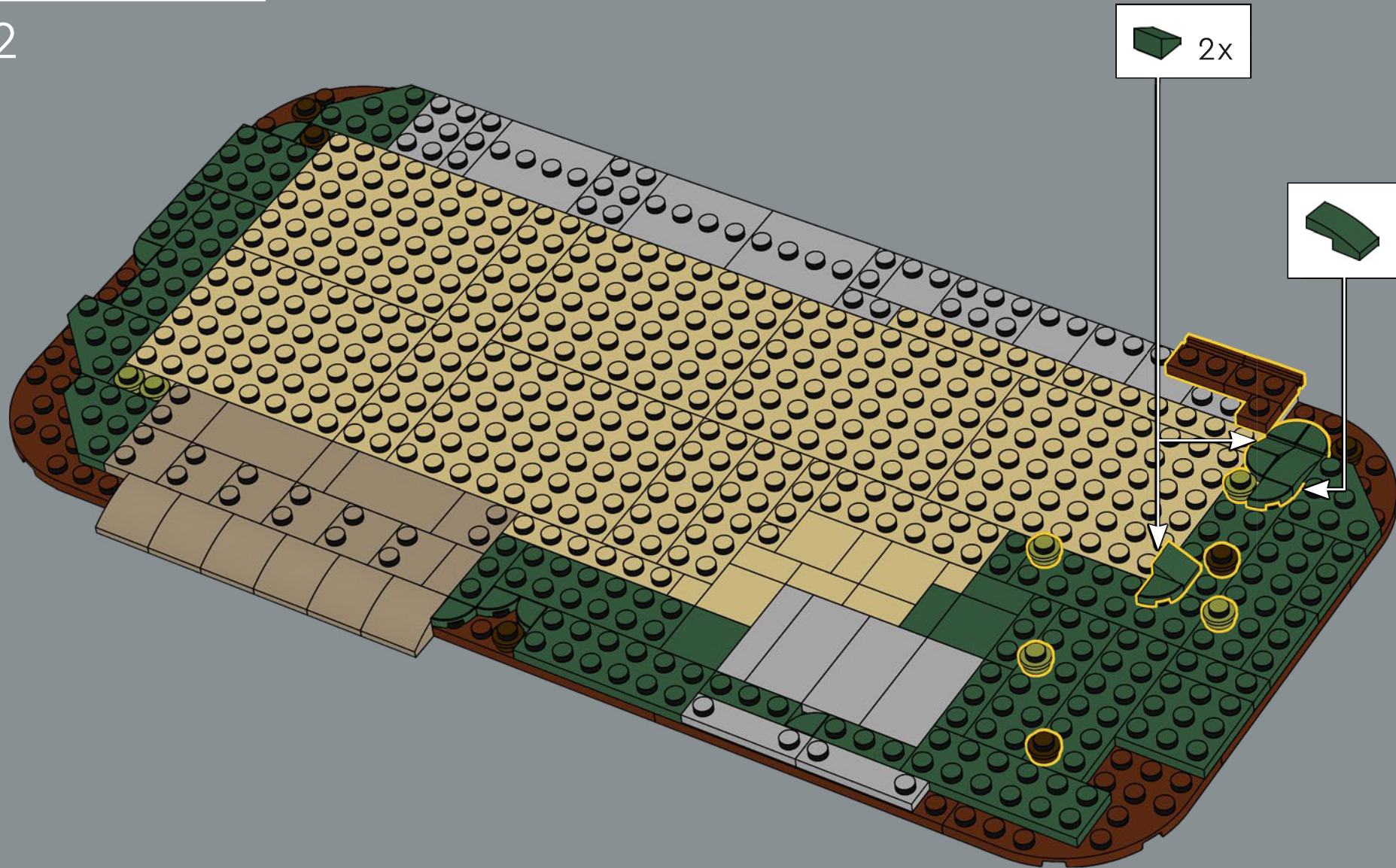

- 4x
- 4x
- 2x
- 1x
- 3x
- 5x

23

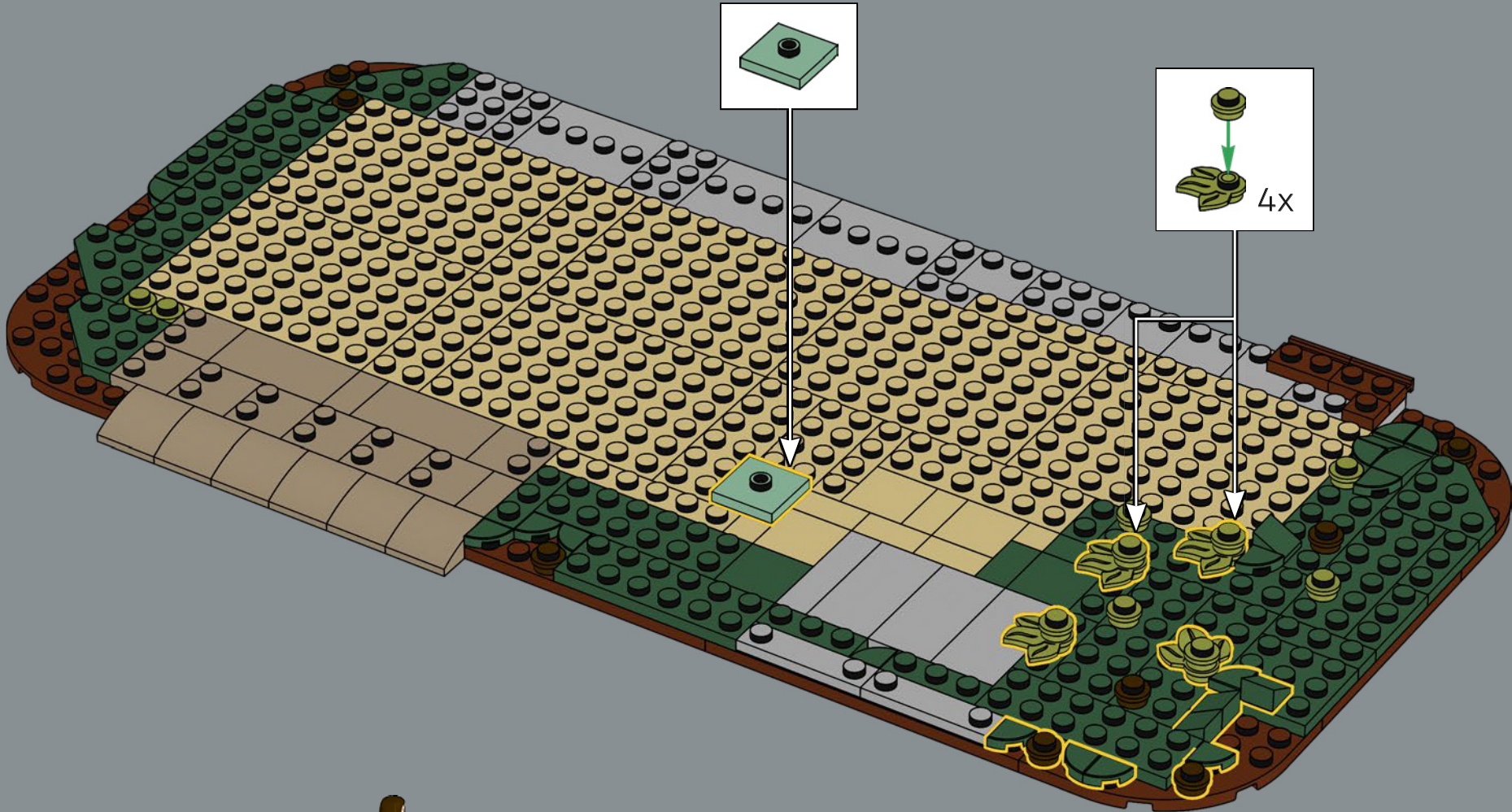

- 3x 
- 3x 
- 1x 
- 1x 

24

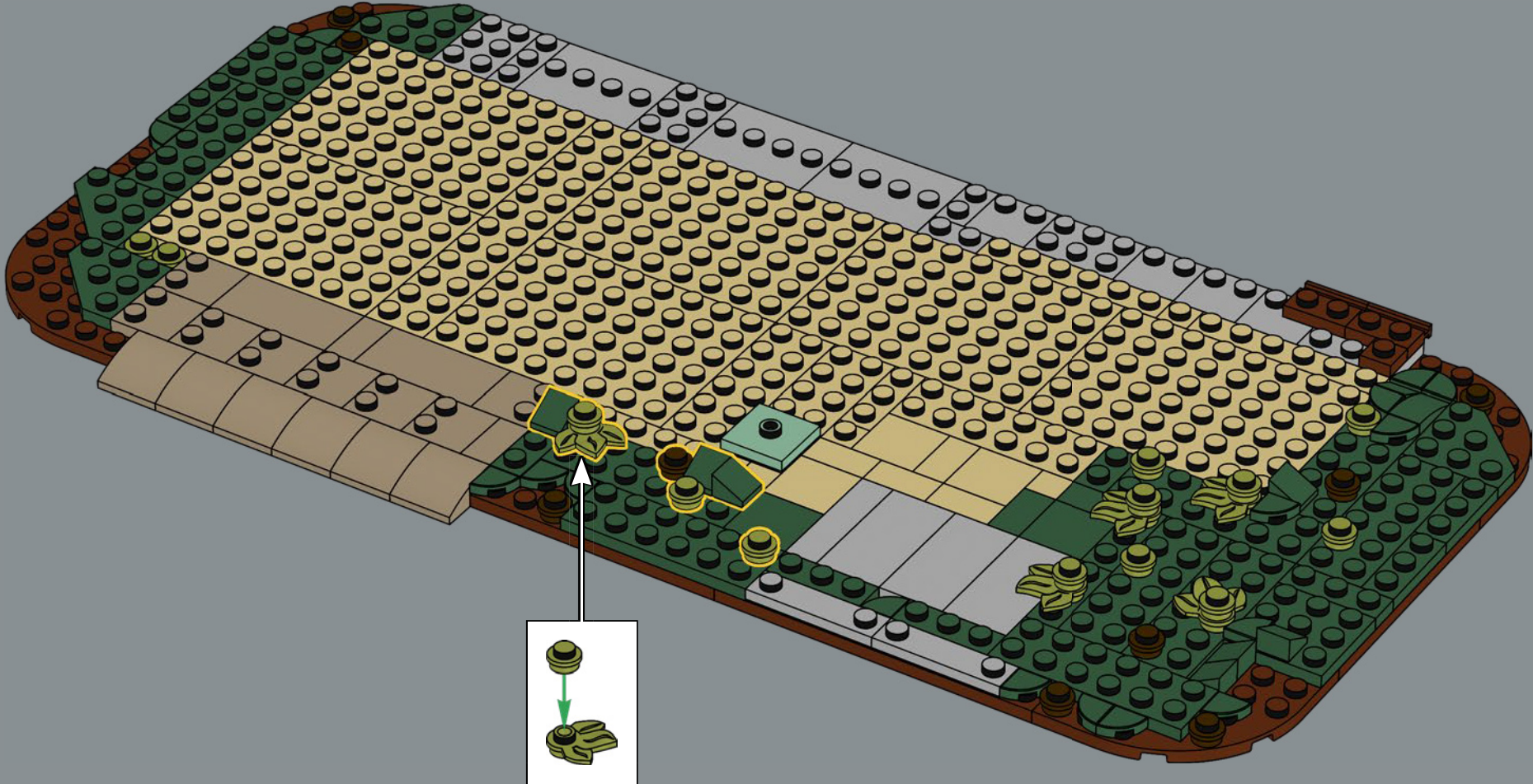

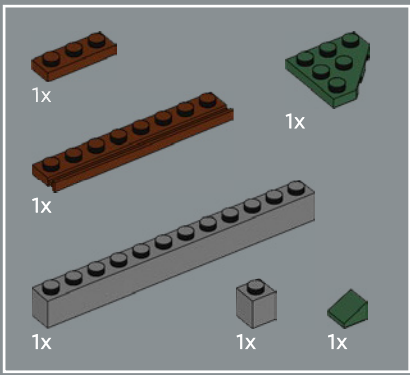

25

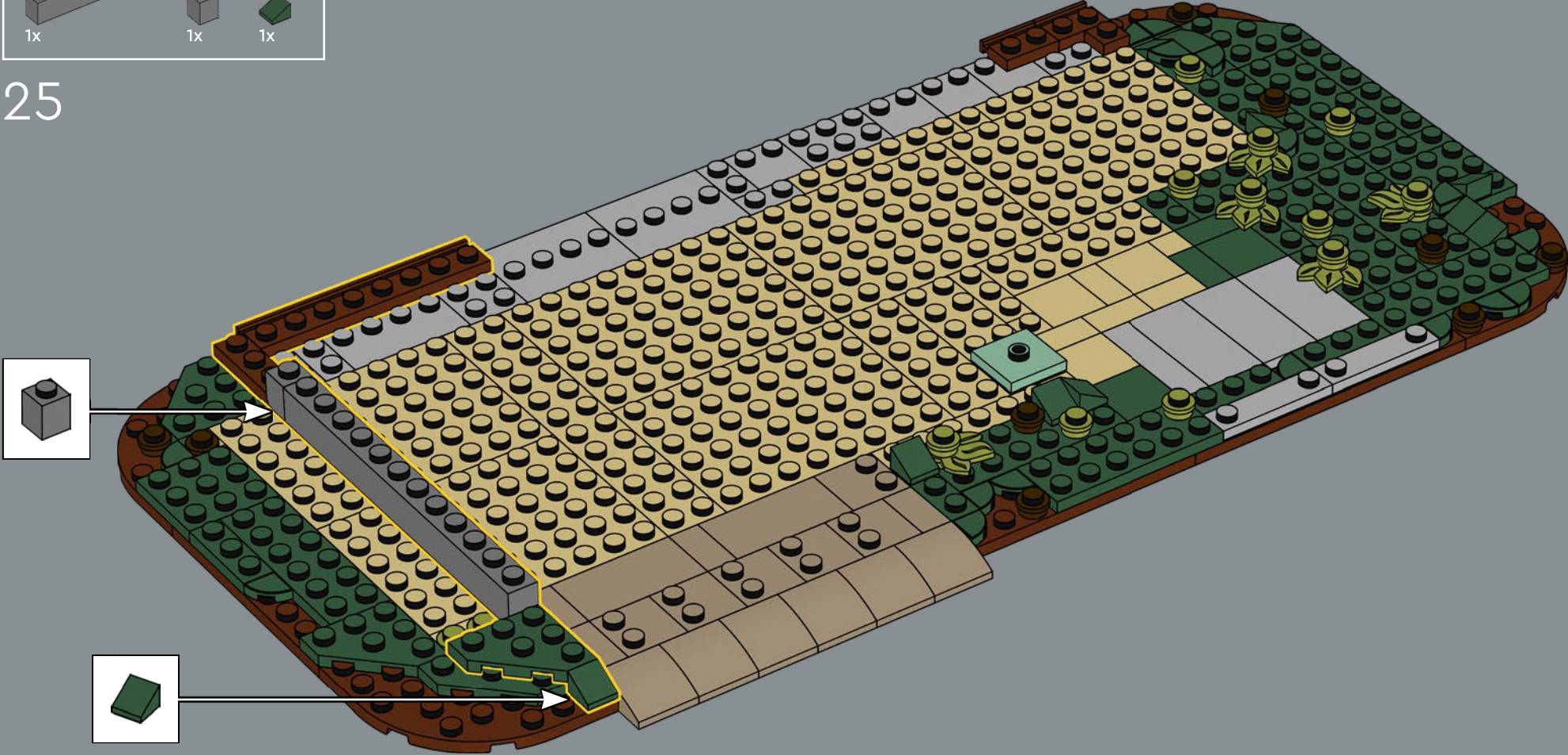

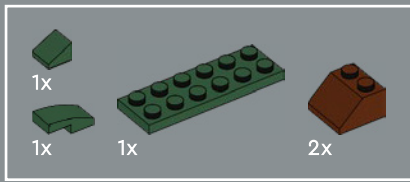

26

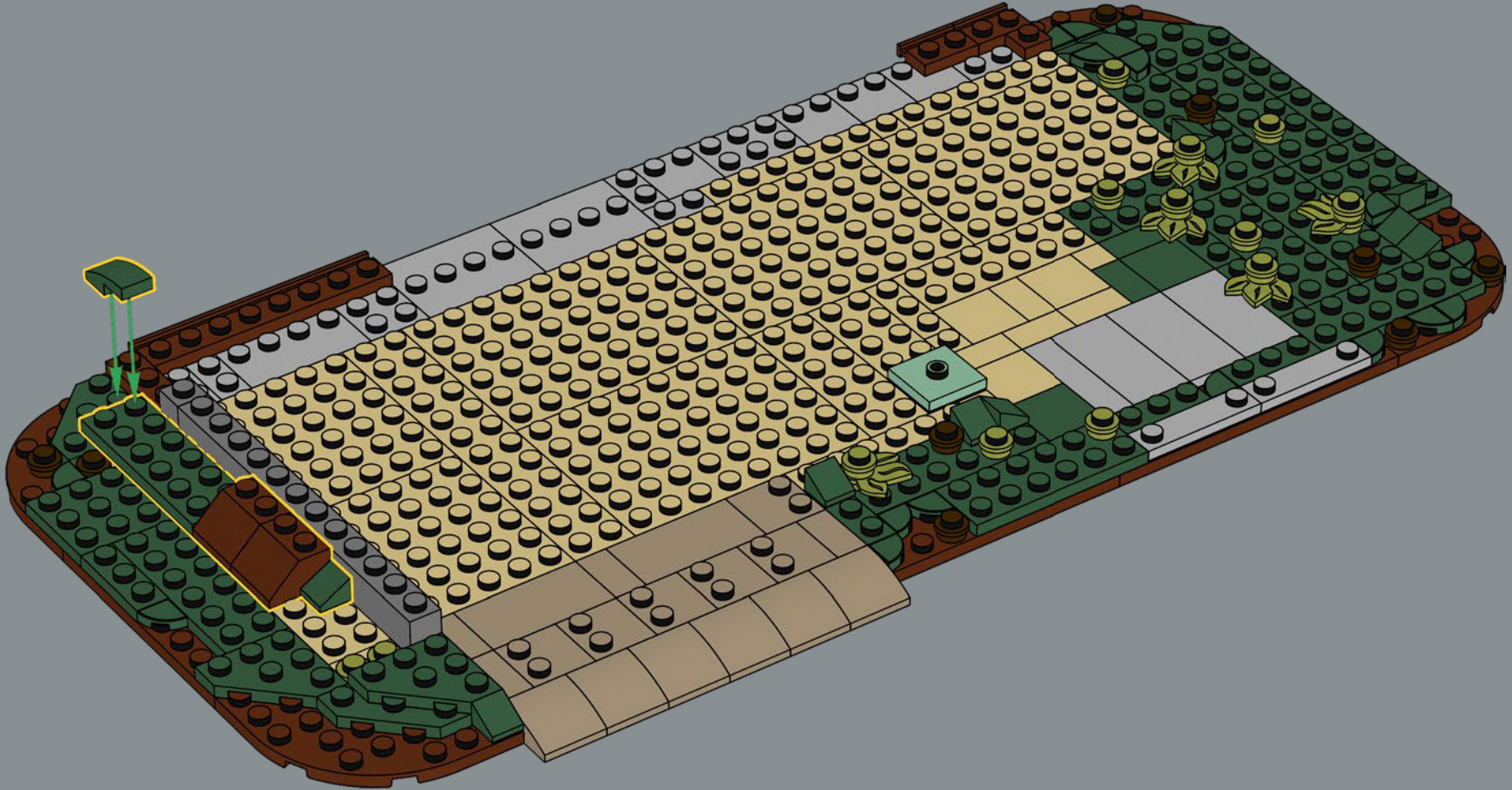

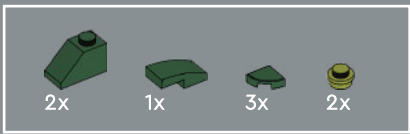

27

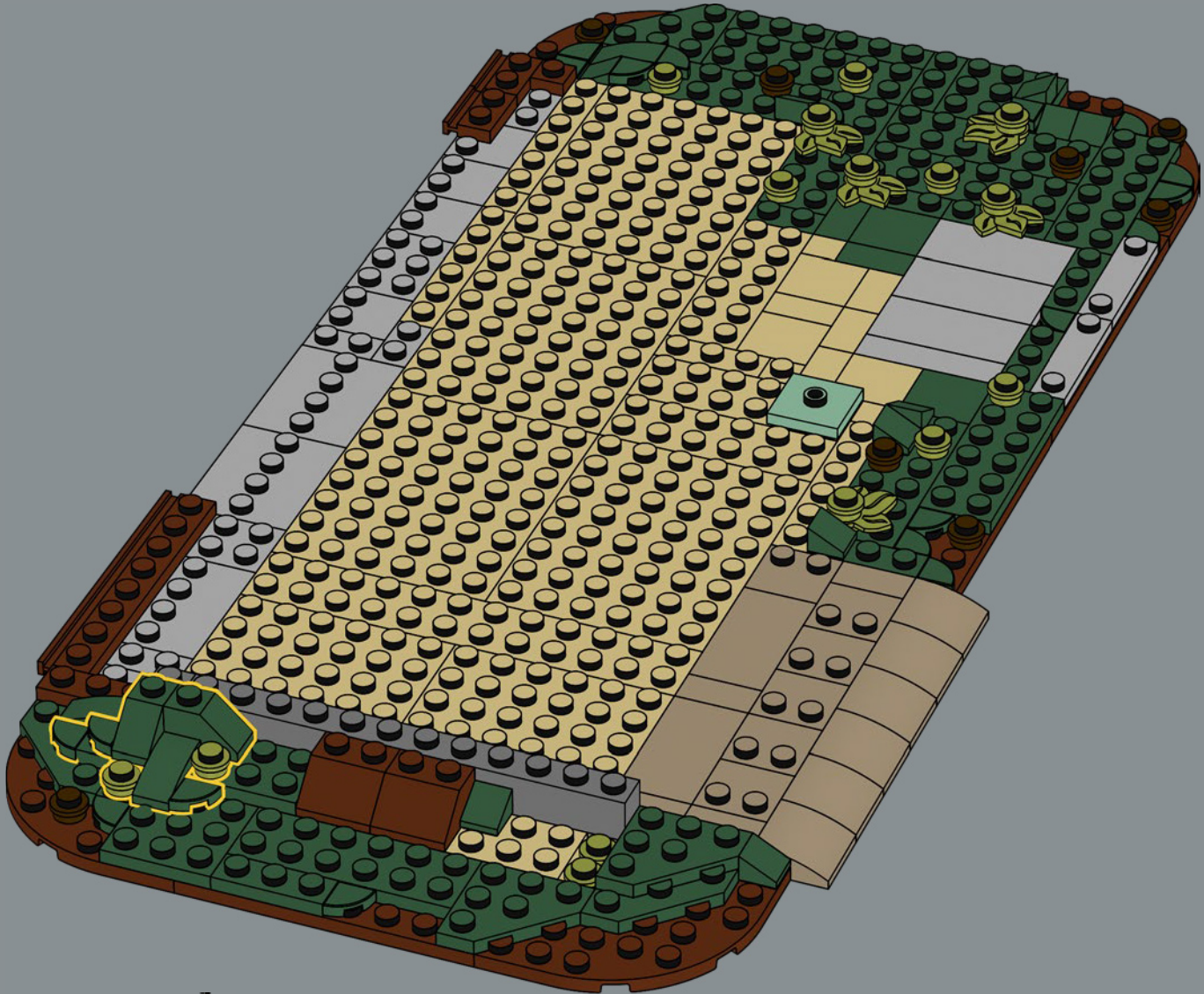

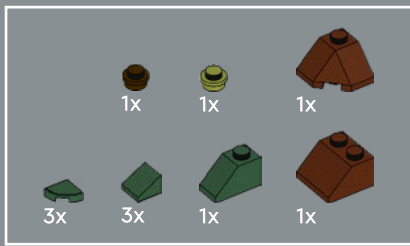

28

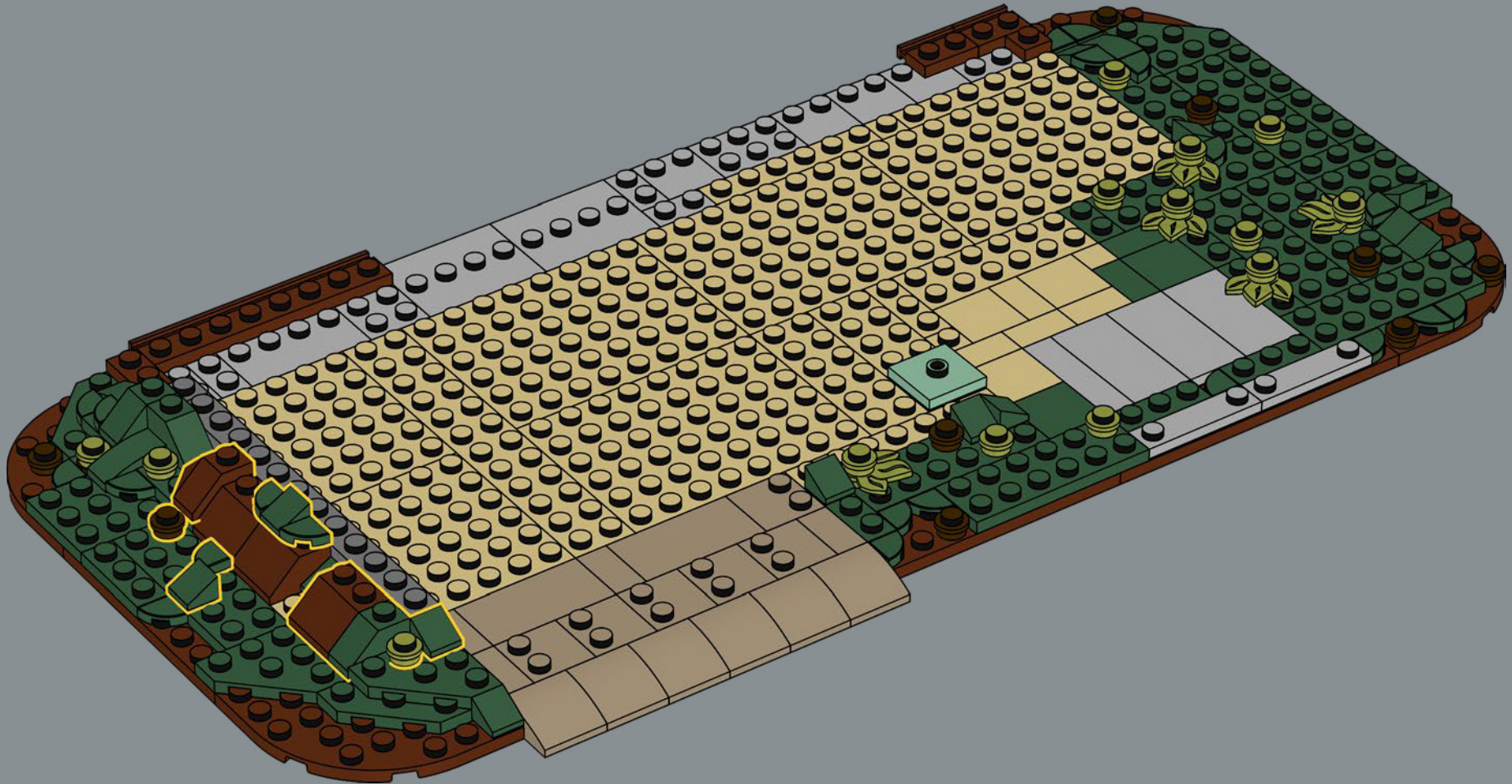

- 2x 
- 3x 
- 2x 
- 4x 

29

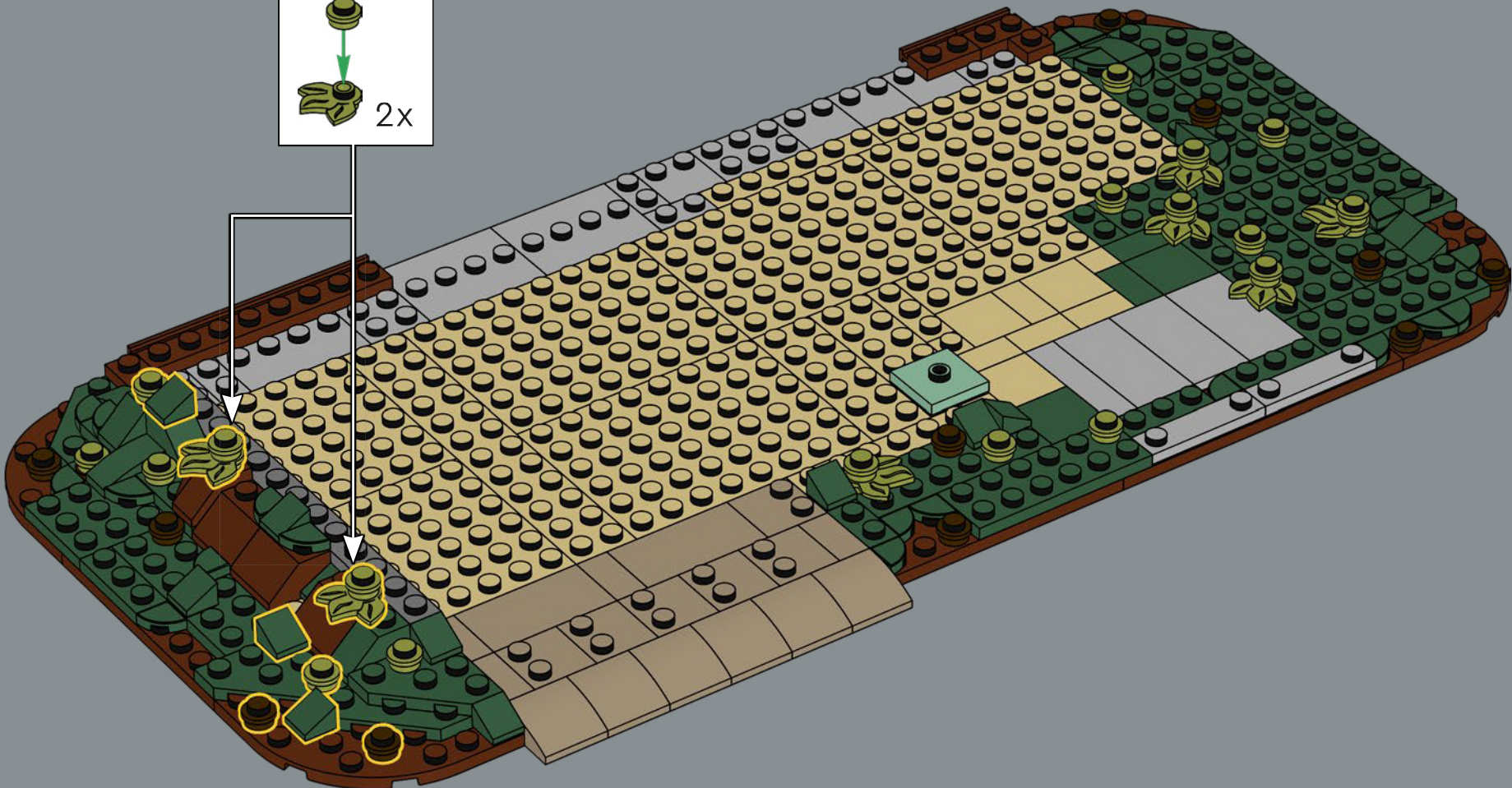
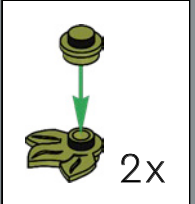

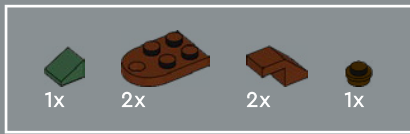

30

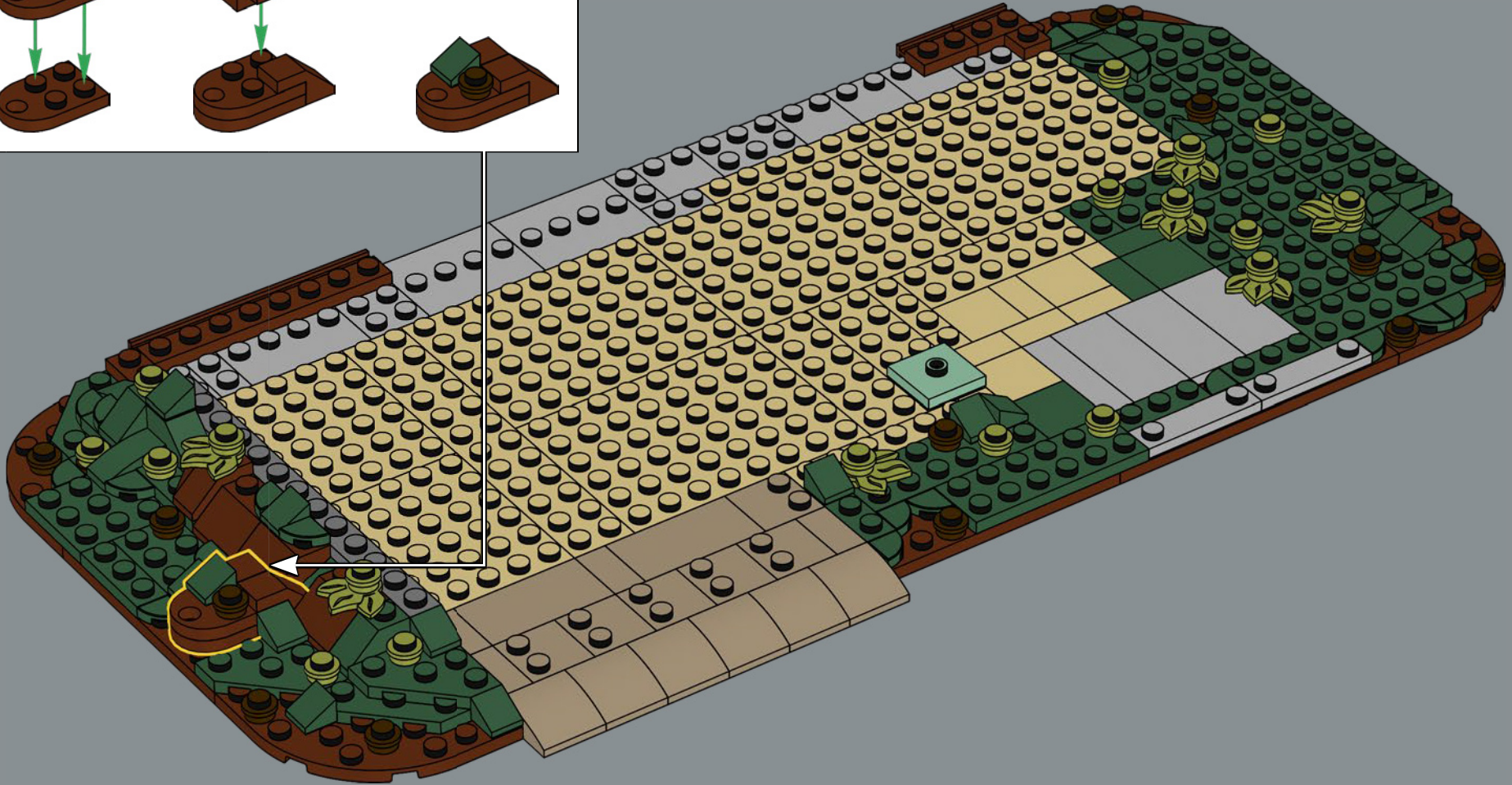
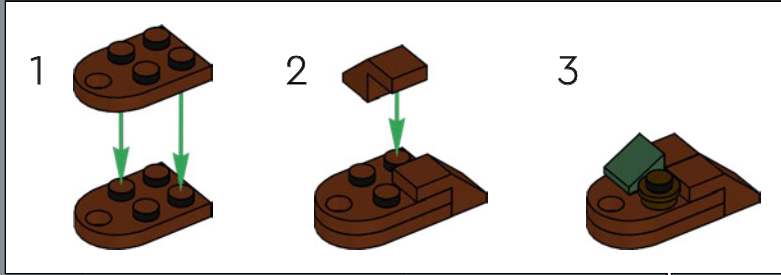

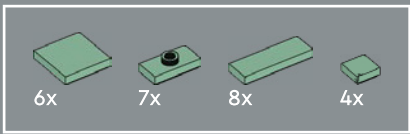

31

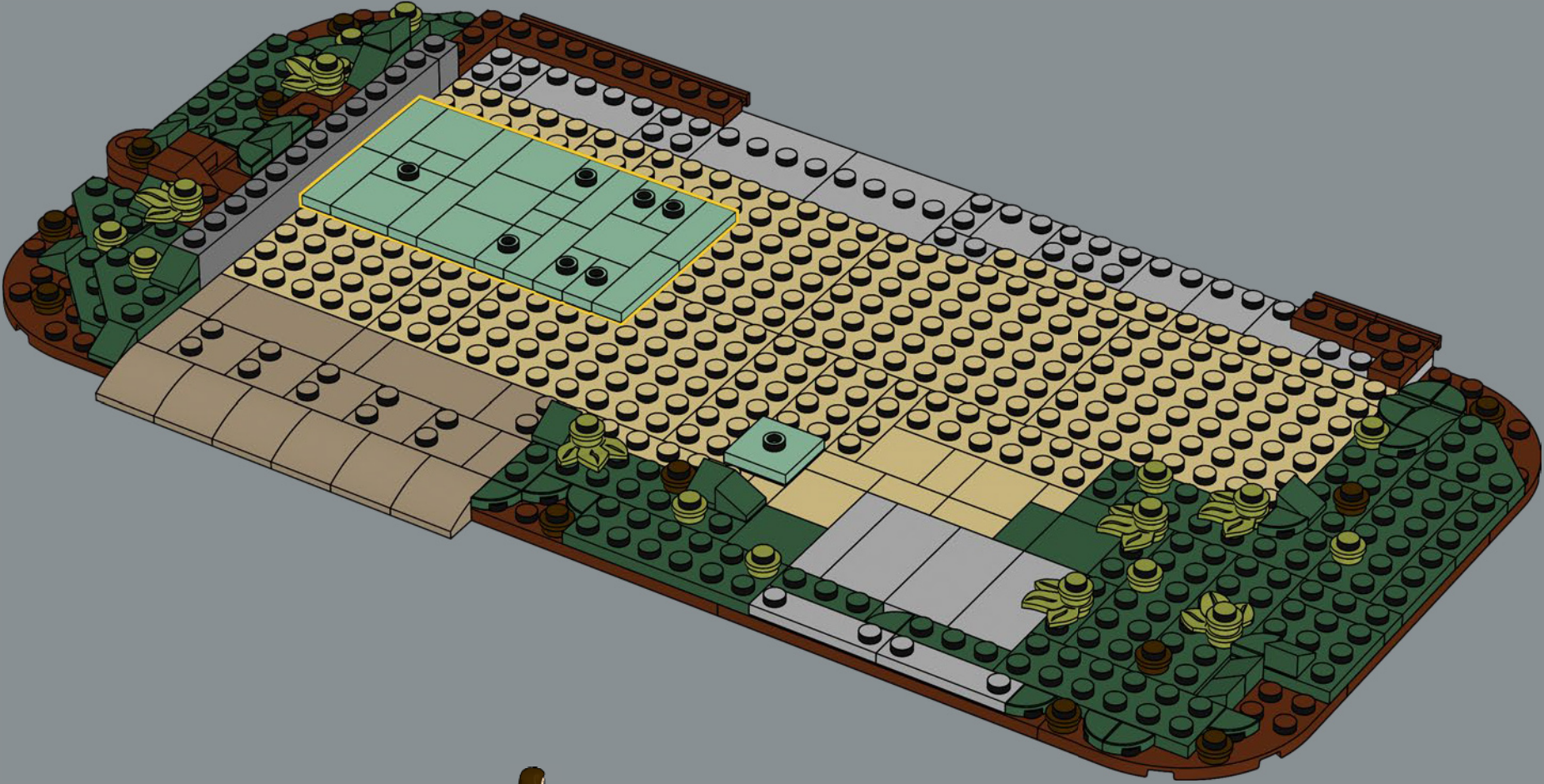

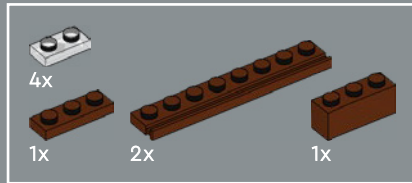
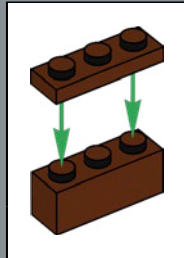
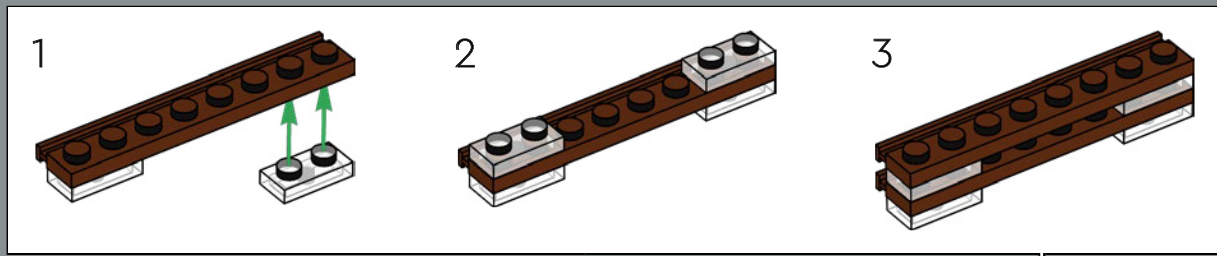

32

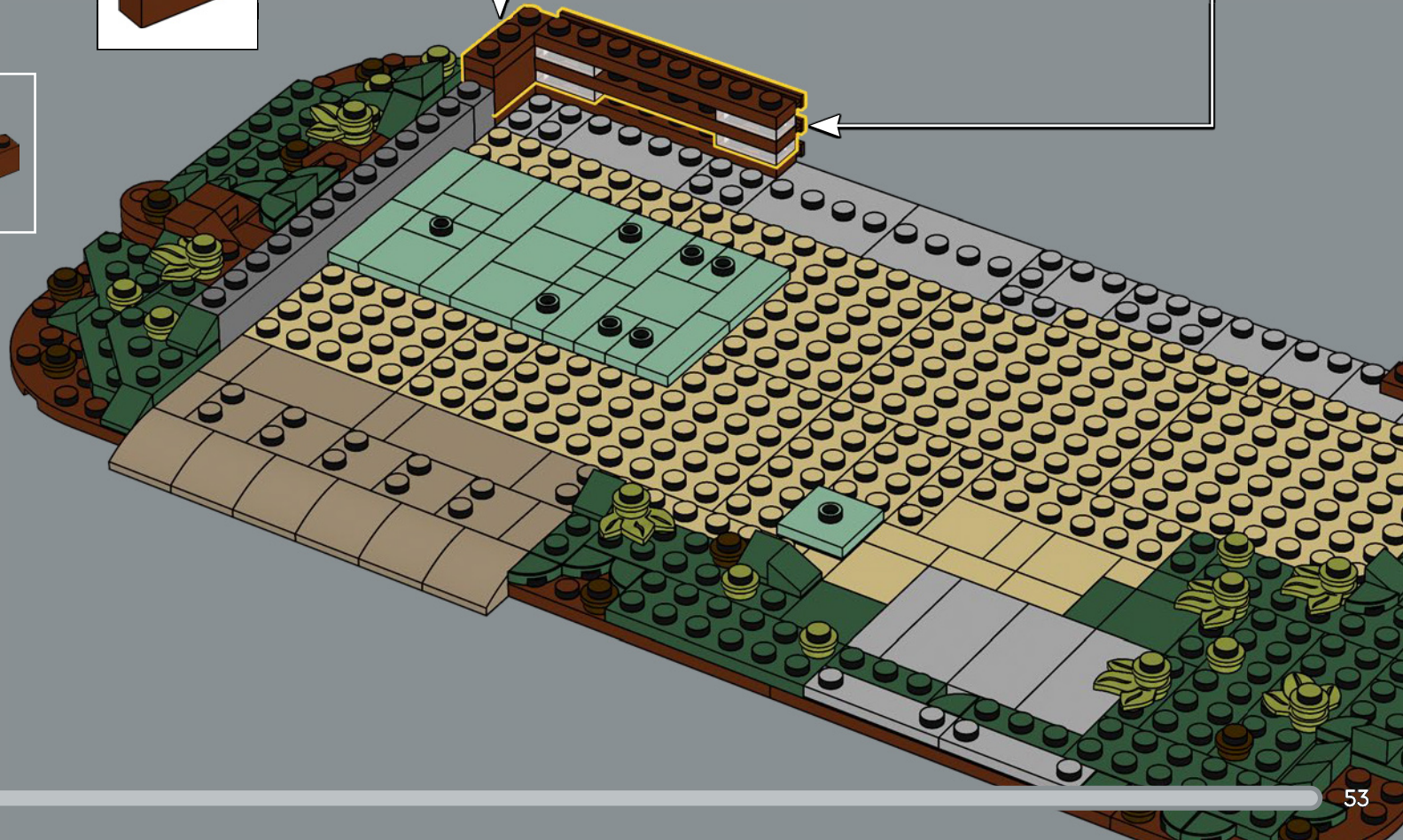

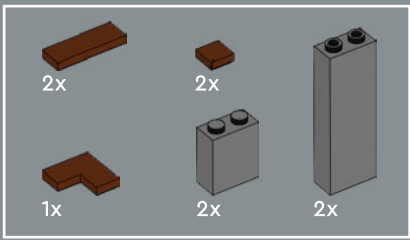

33

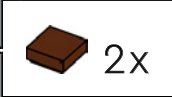
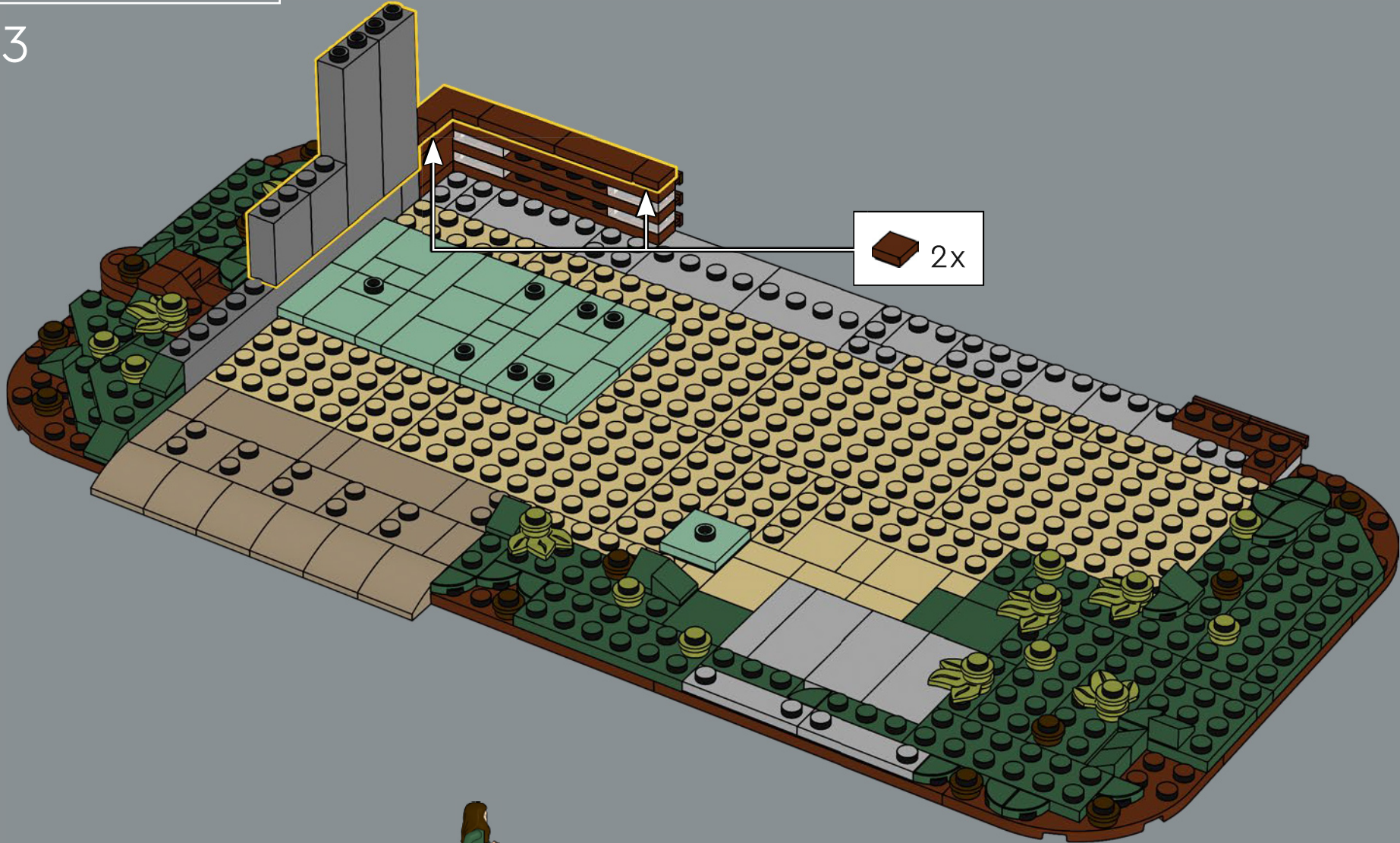

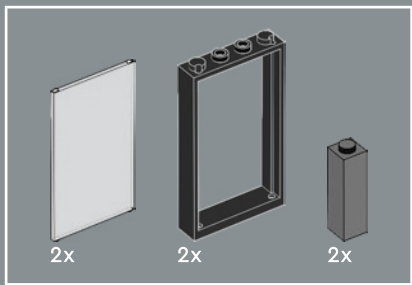

35

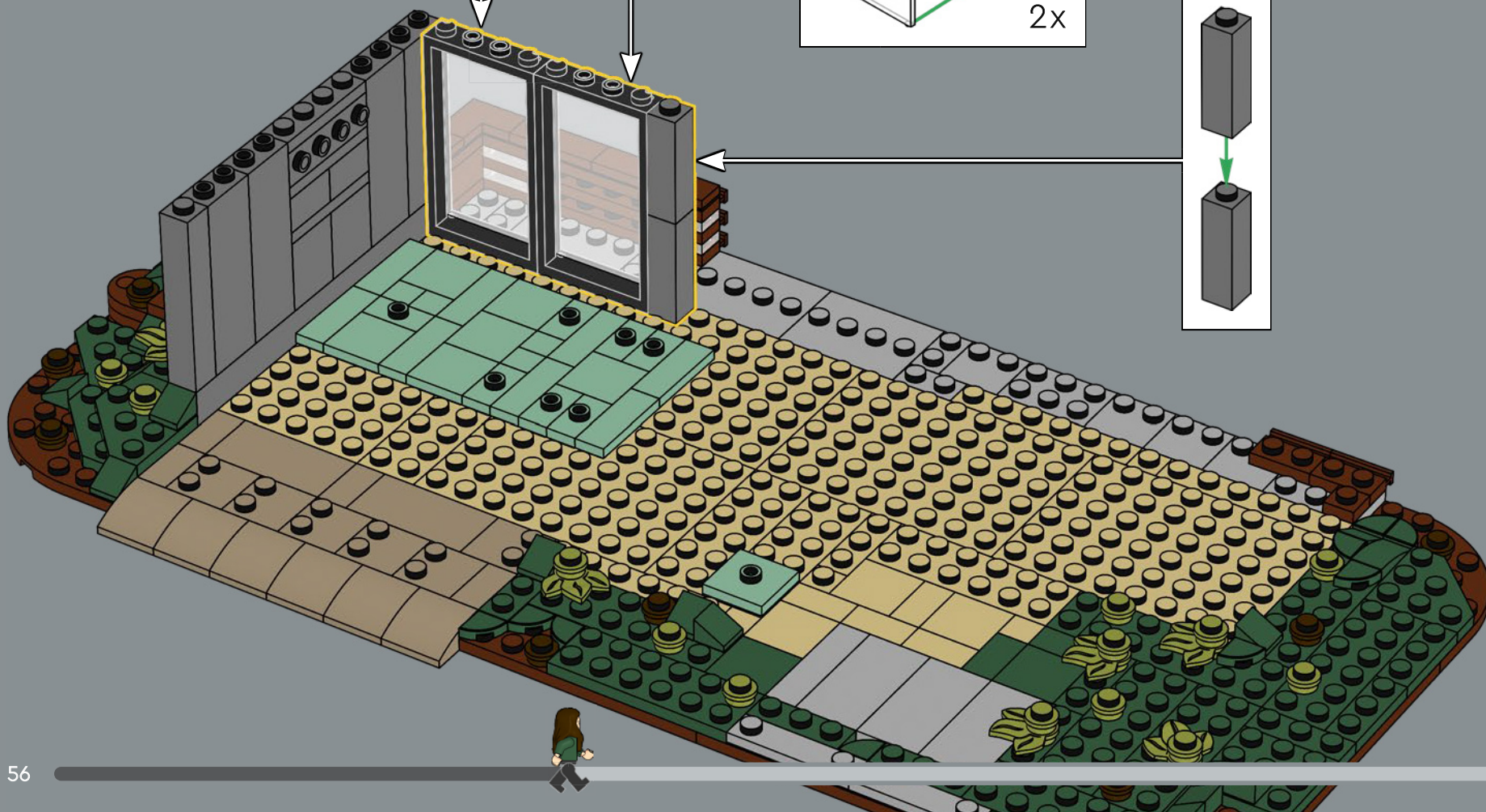
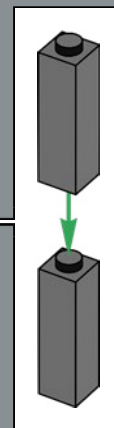
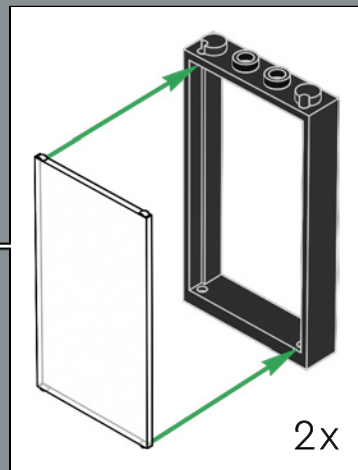

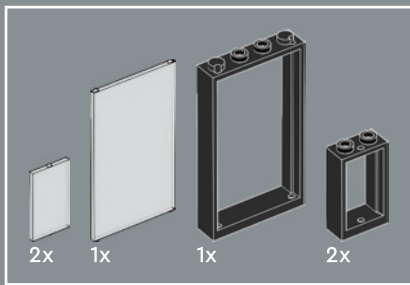

36

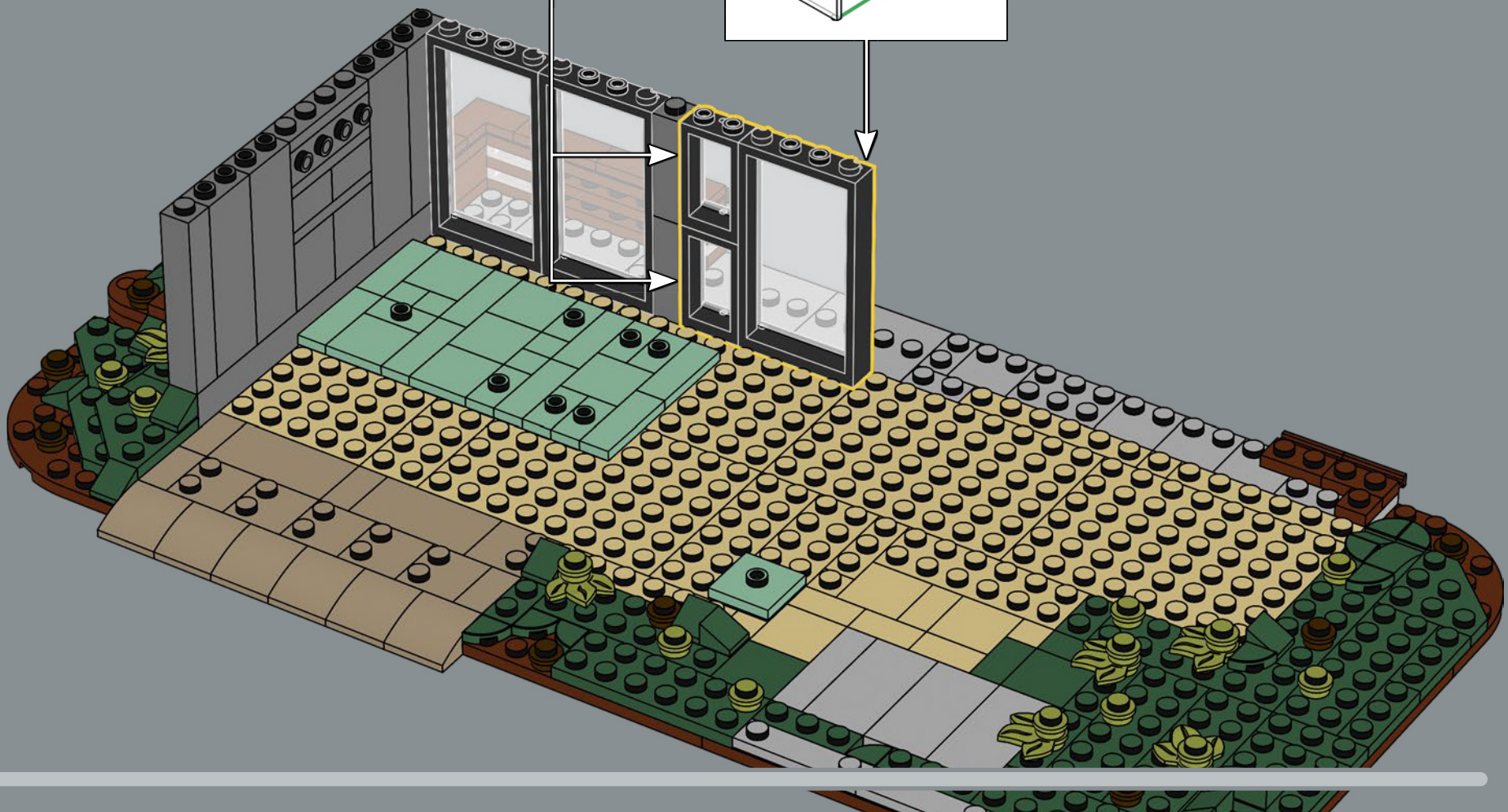
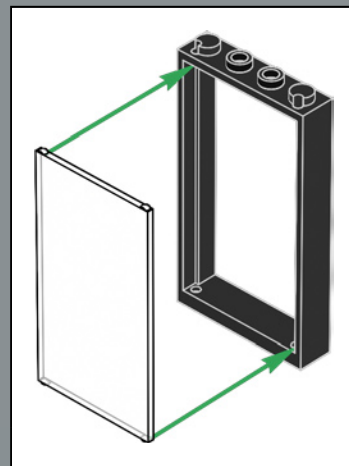
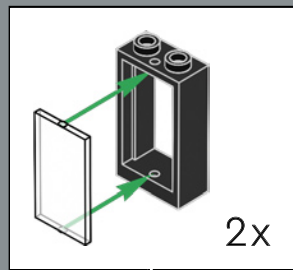

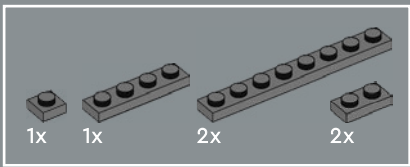

37

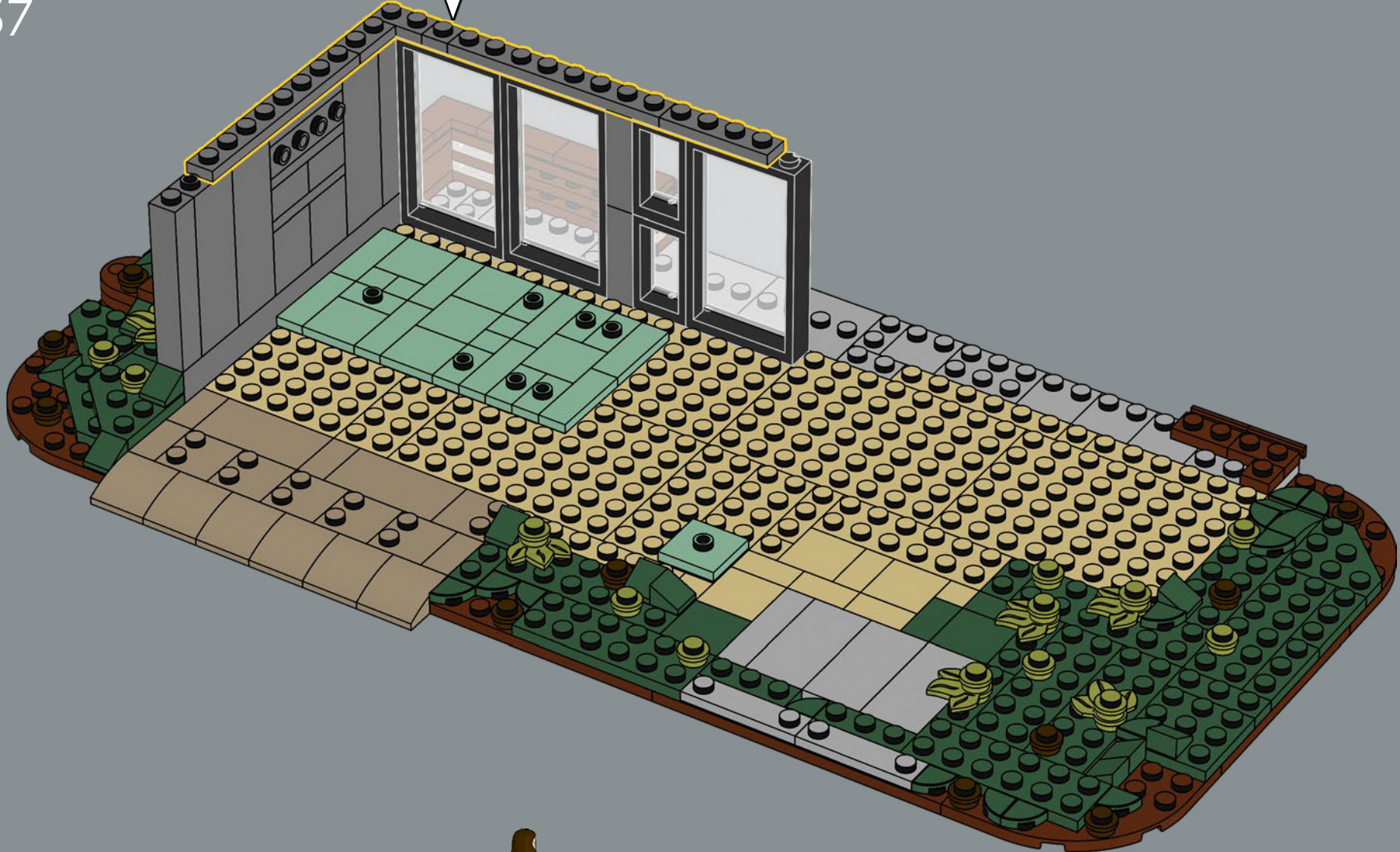
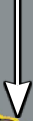

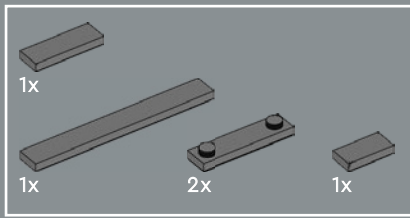

38

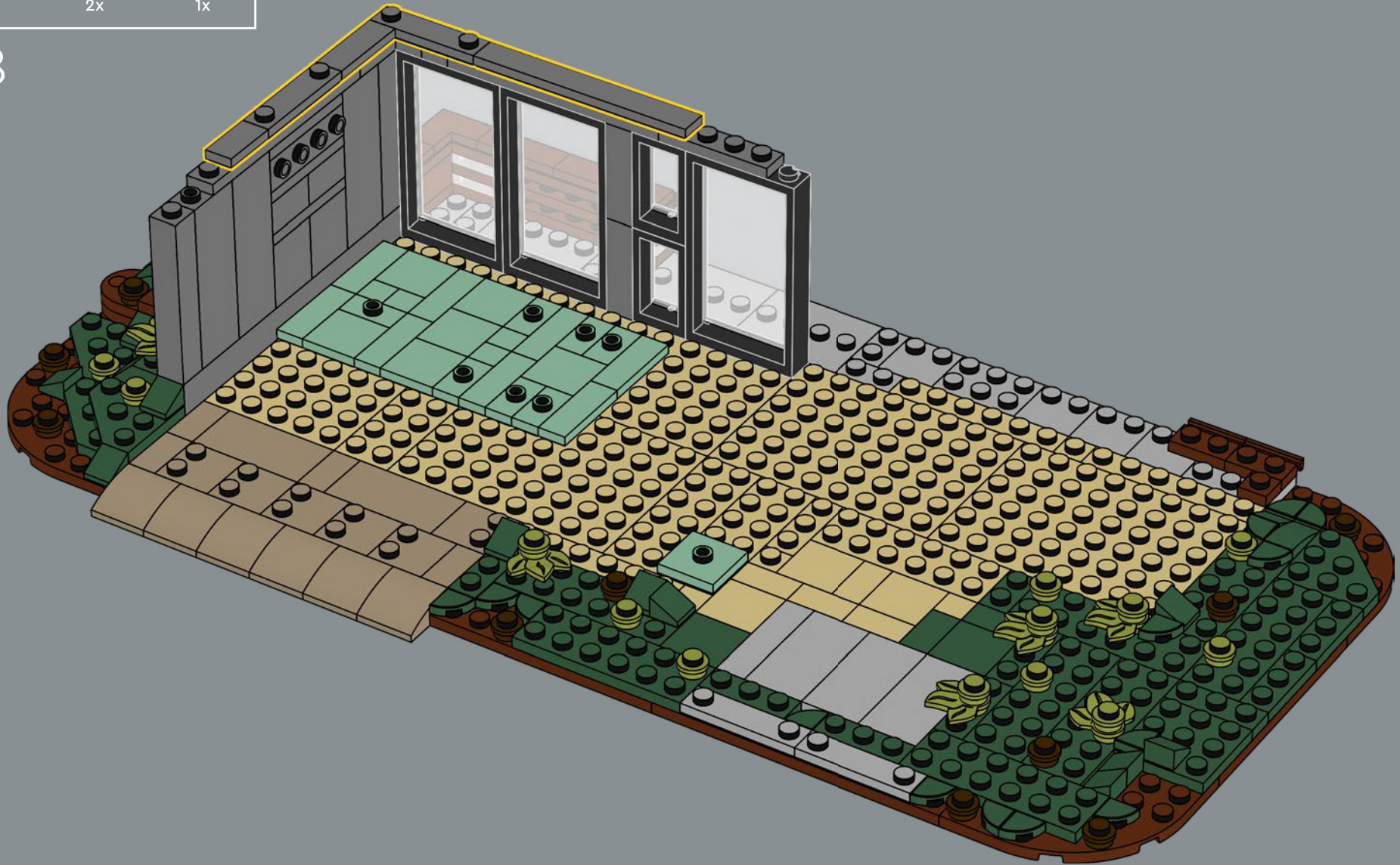

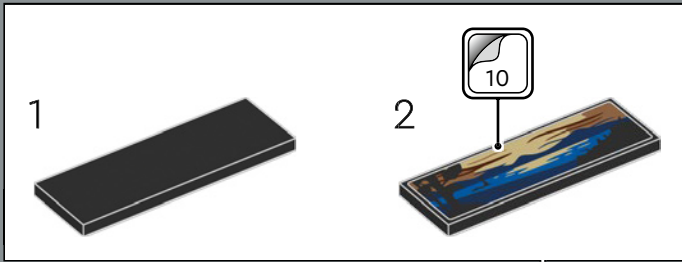
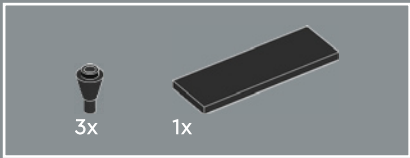

39

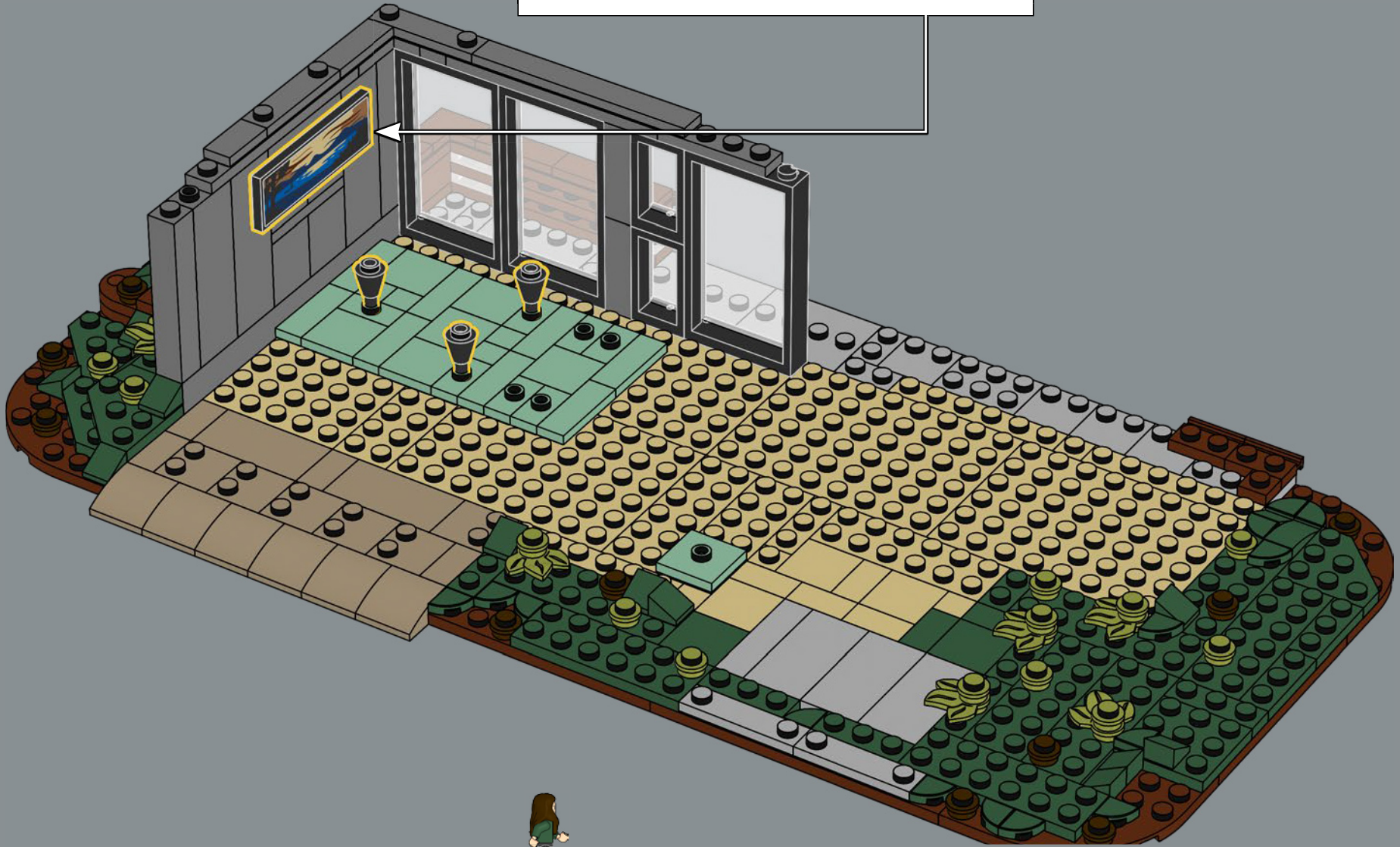

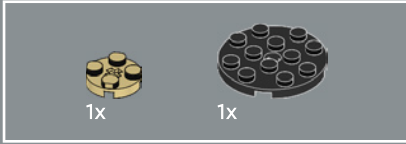

40

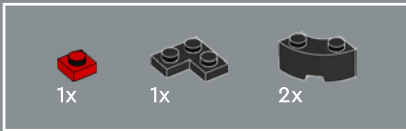

41

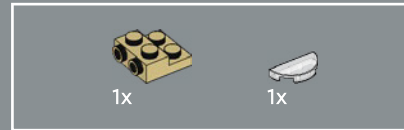

42

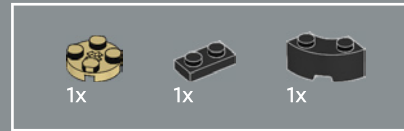
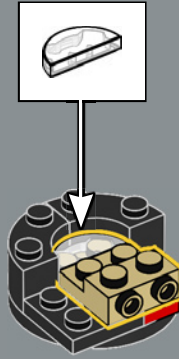

43

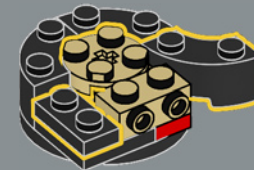

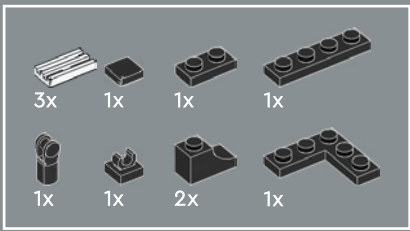

44

1

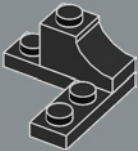

3

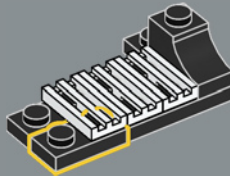

5

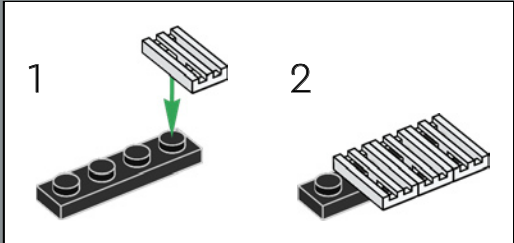
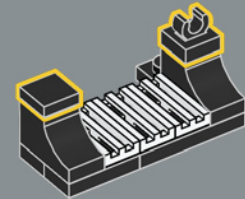

2

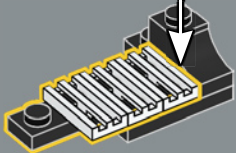

4

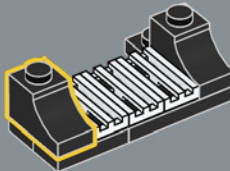

6

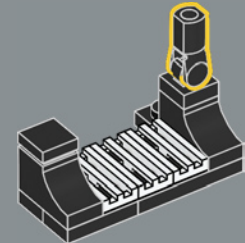

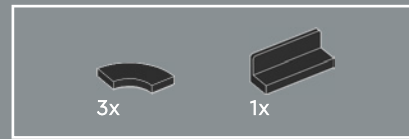
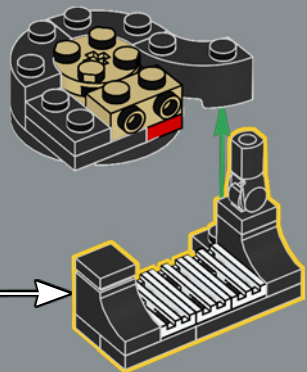

45

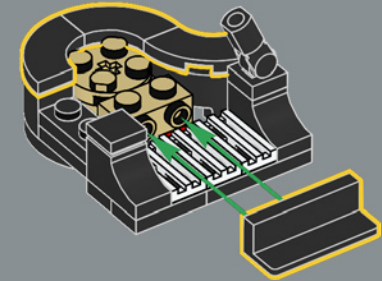

46

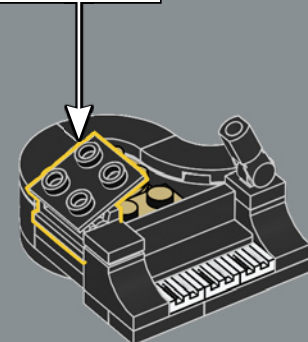
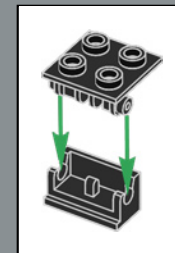

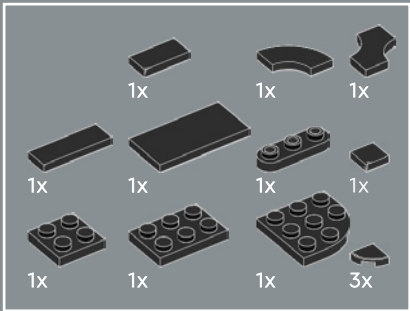

47

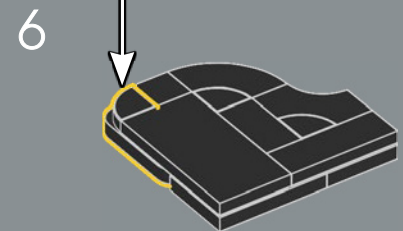
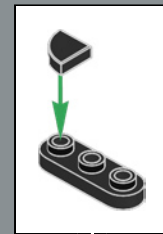
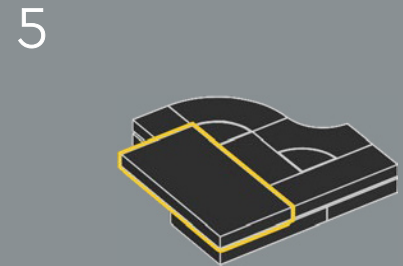
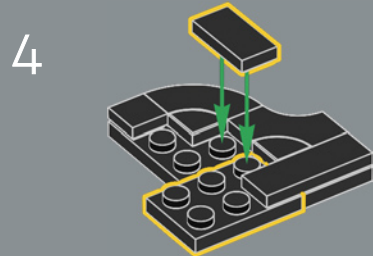
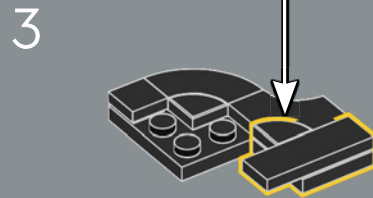
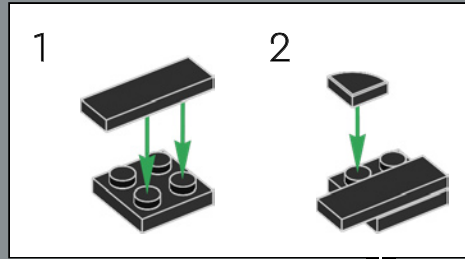
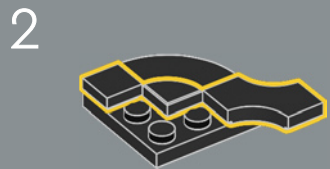
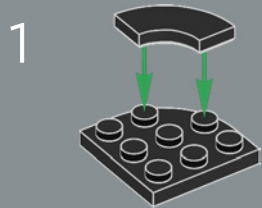

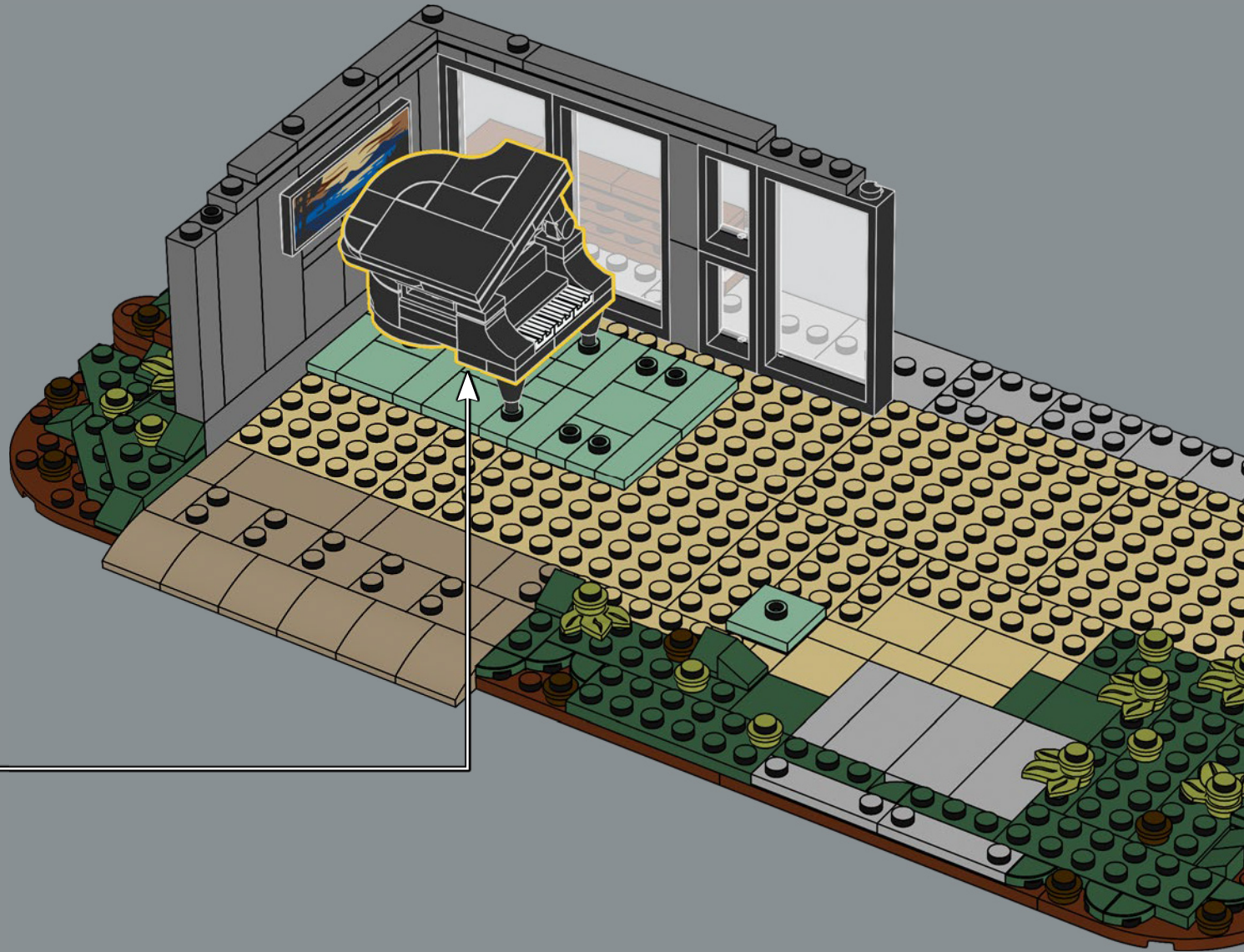
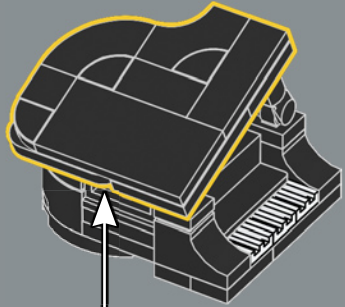

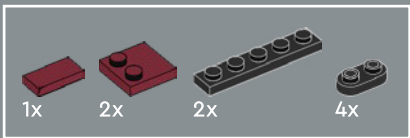

48

1

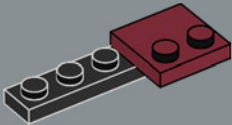

2

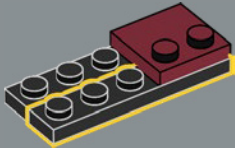

3

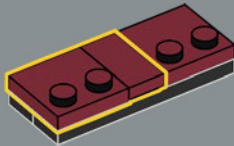

4

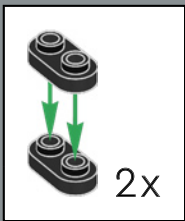
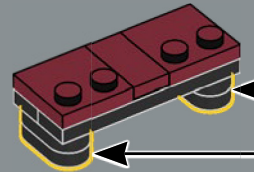

2x

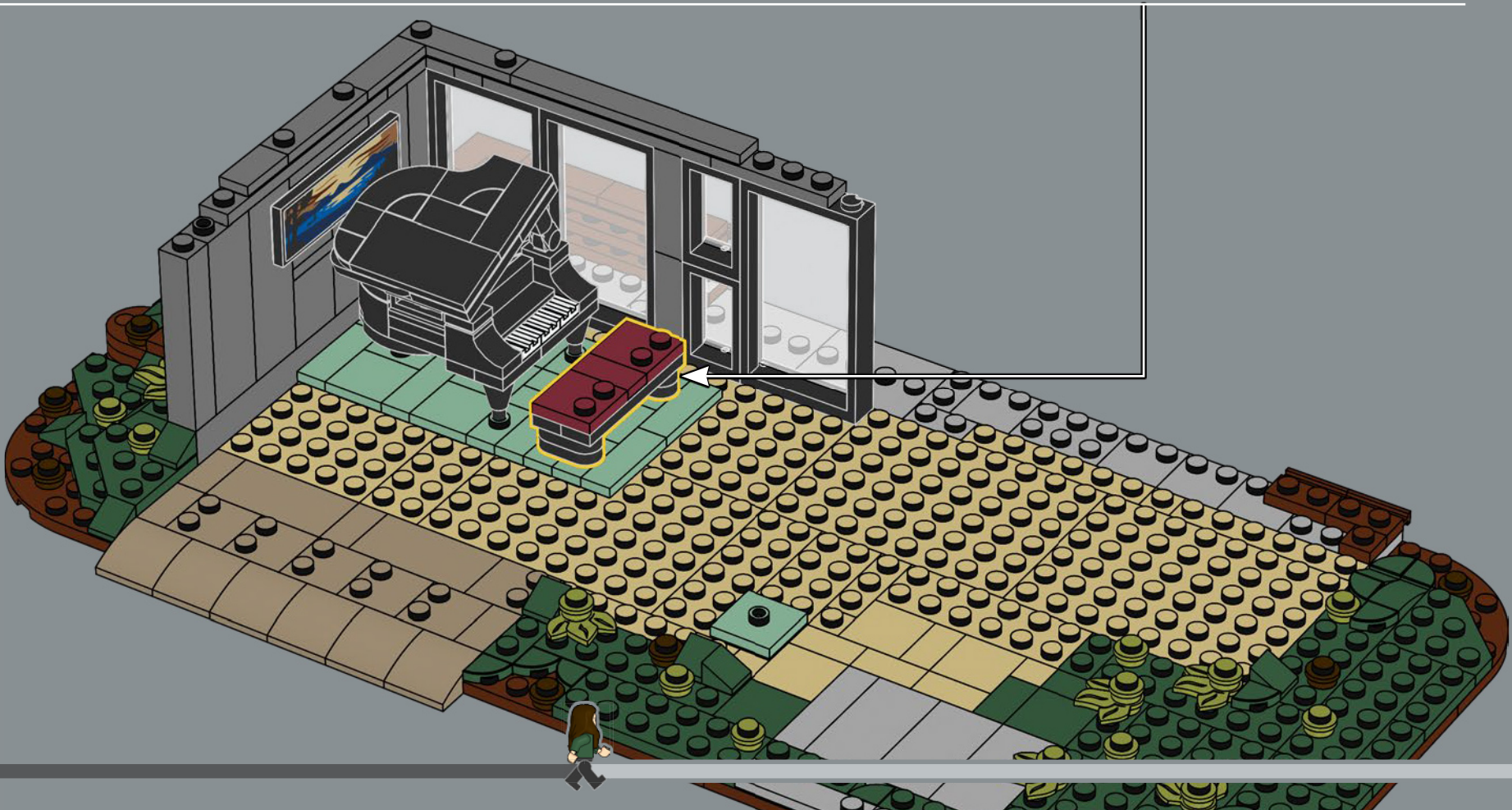

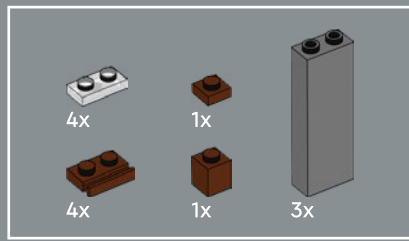

49

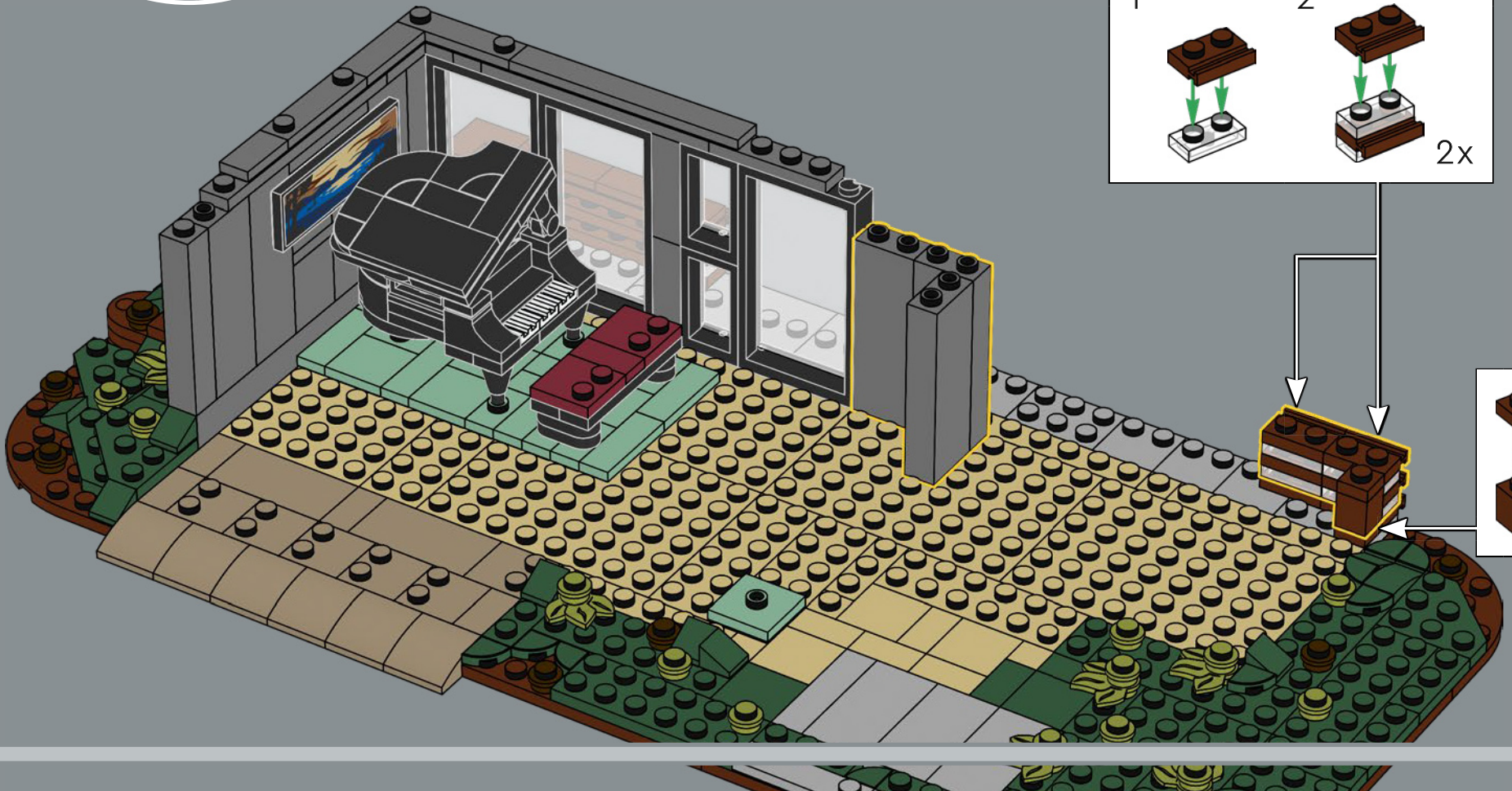

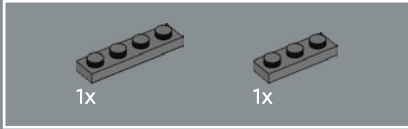
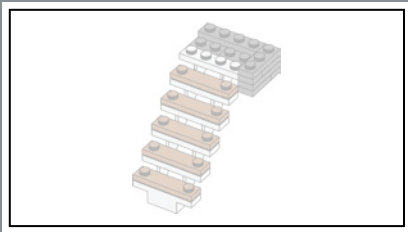

50

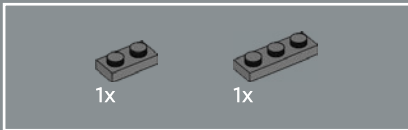
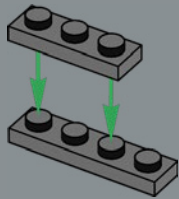

51

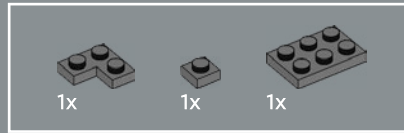
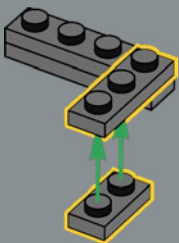

52

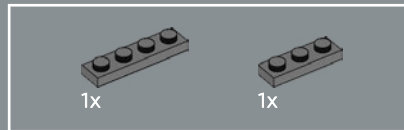
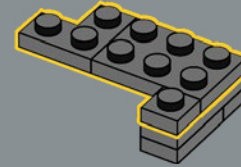

53

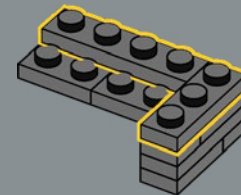

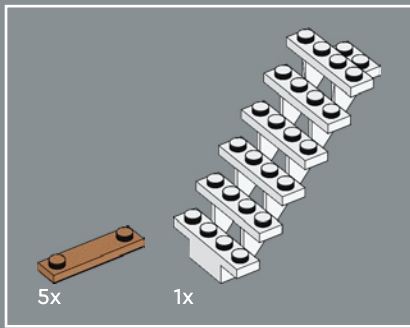

54

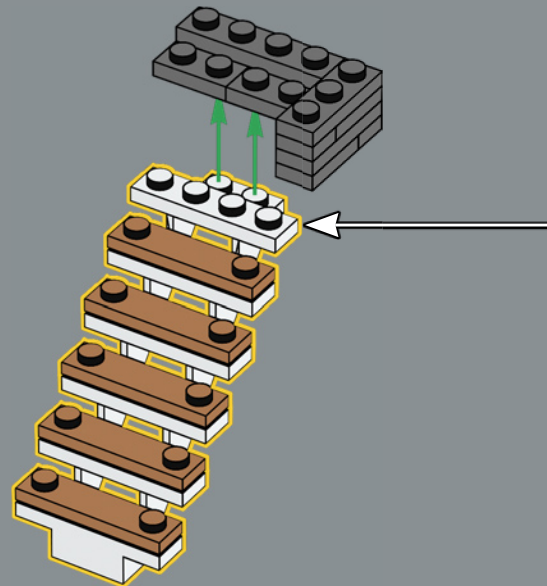
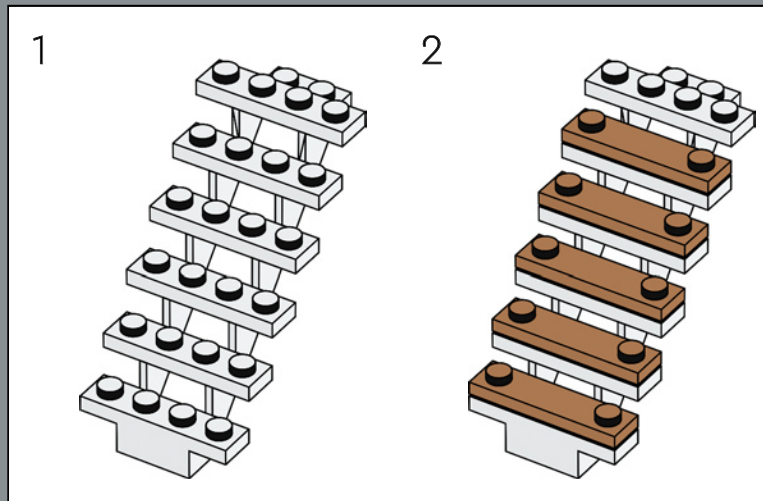



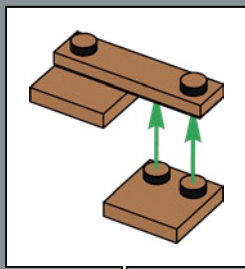
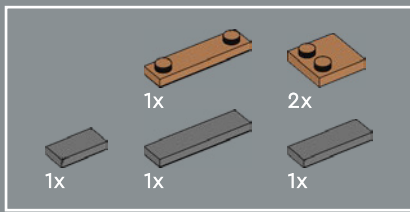

56

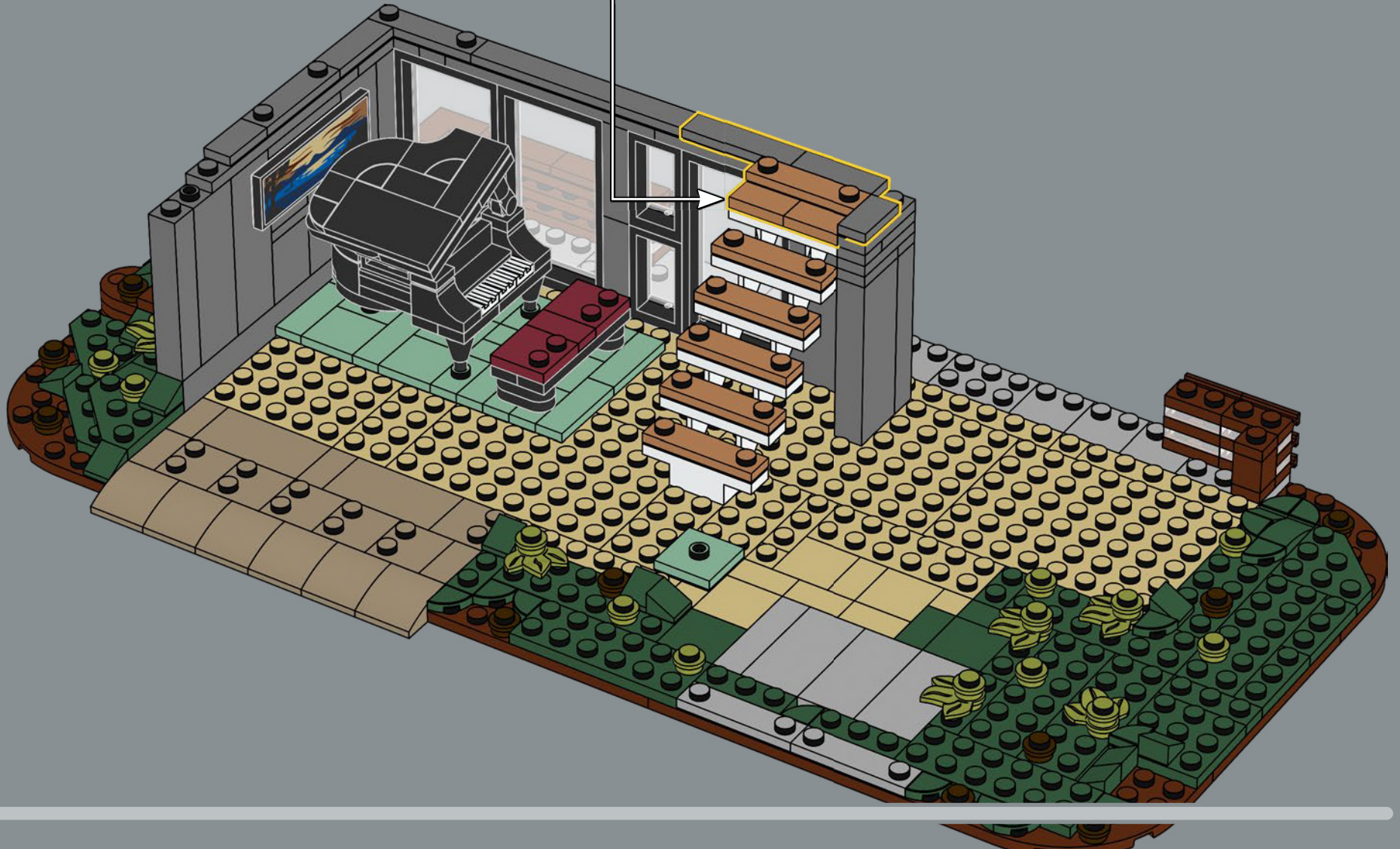

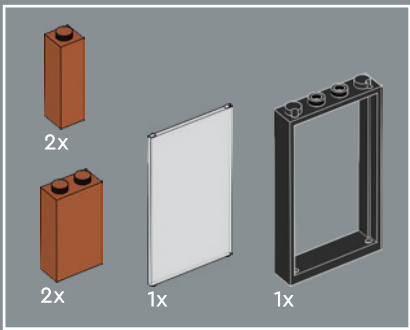

57

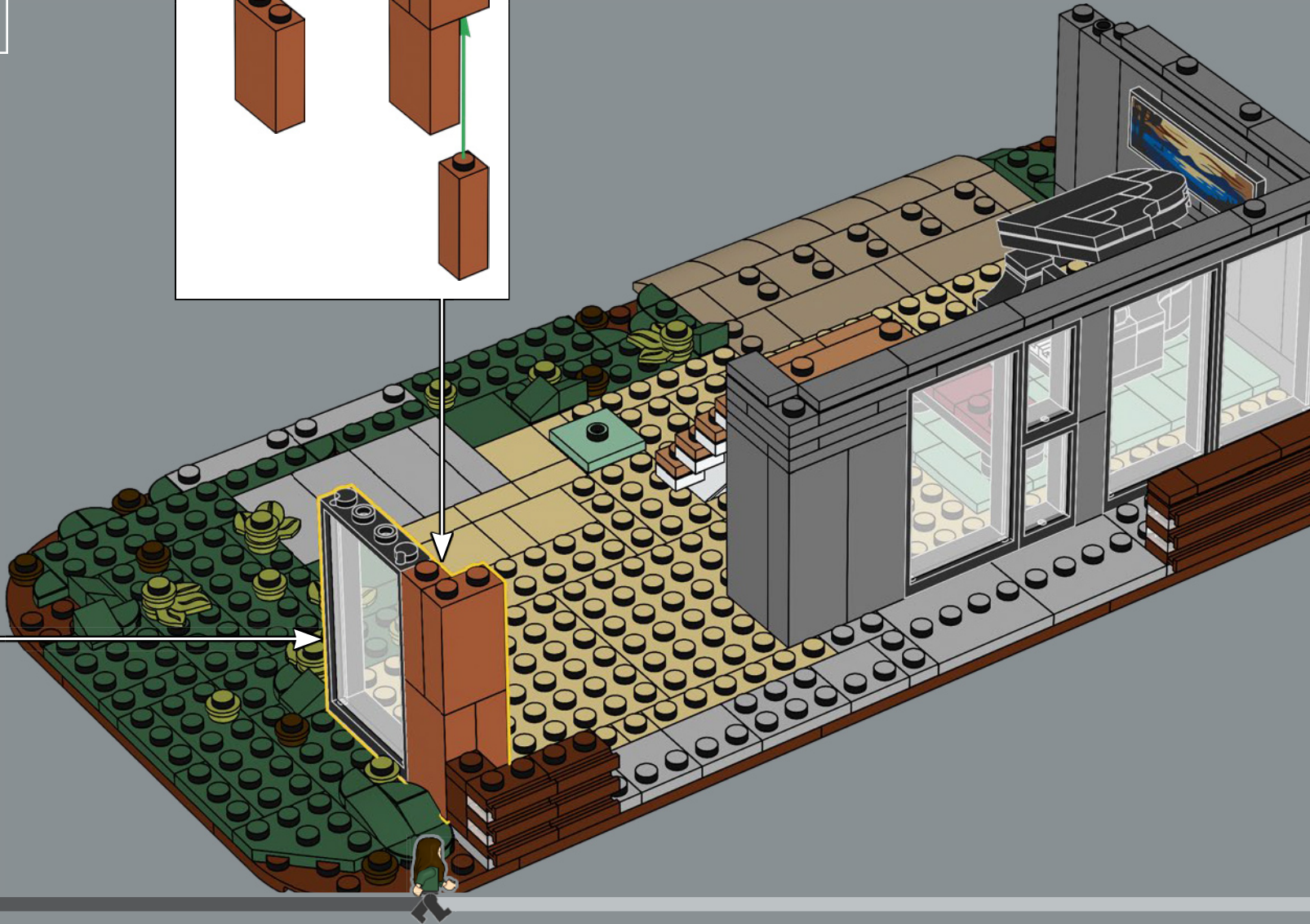
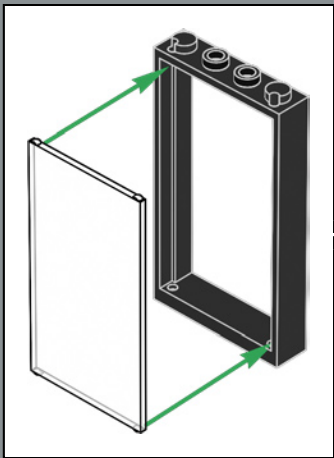
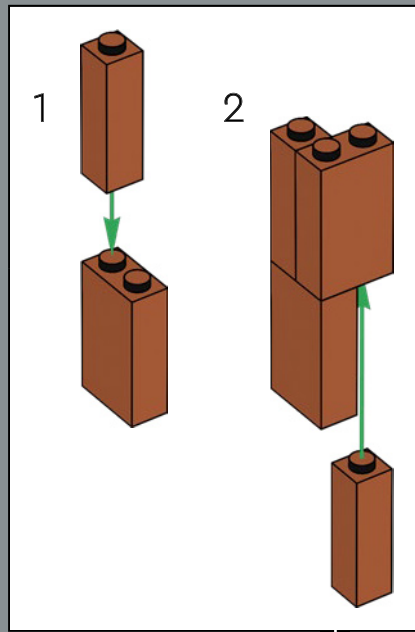

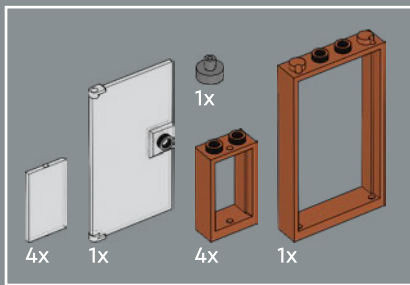

58

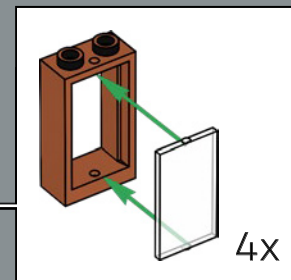
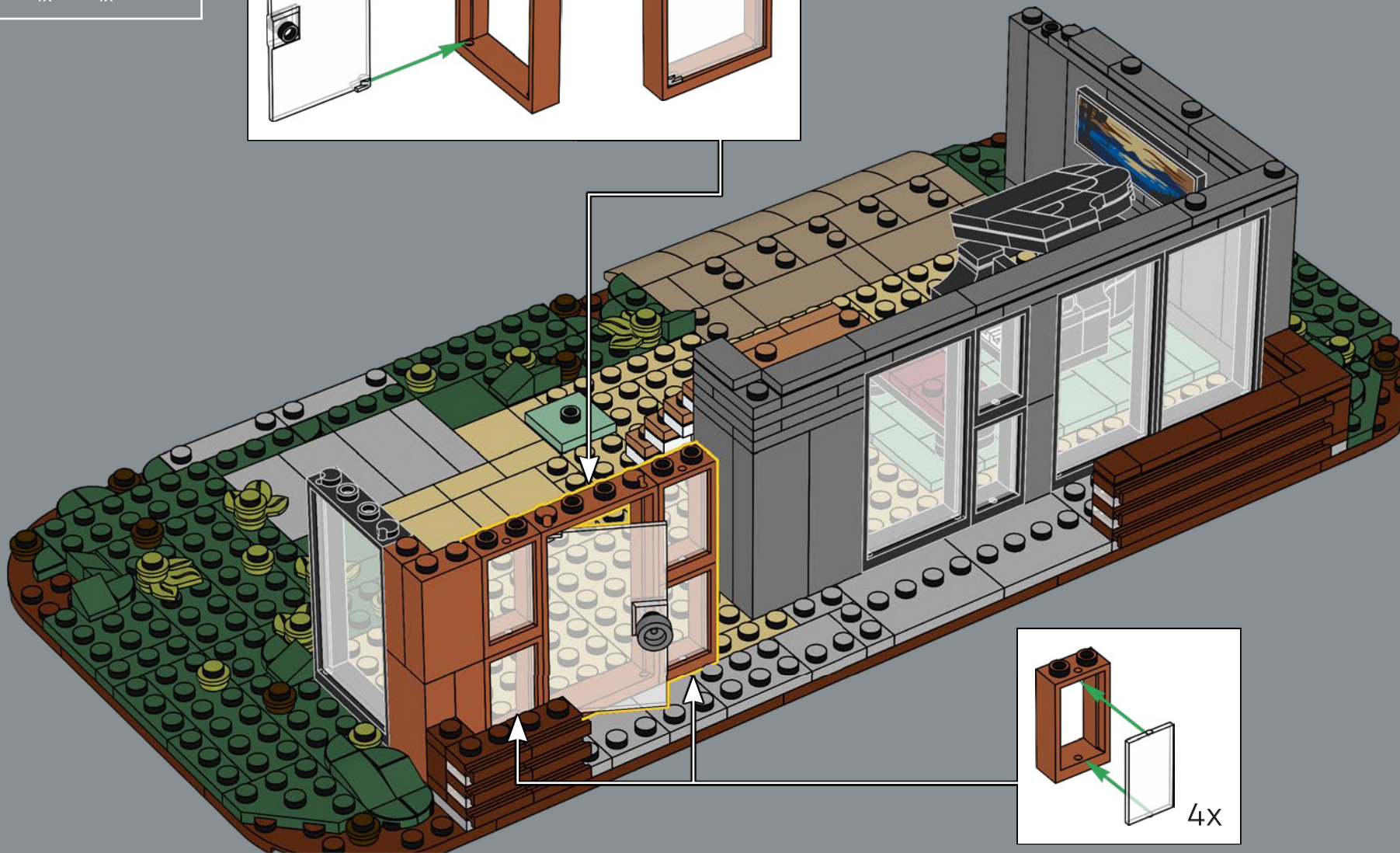
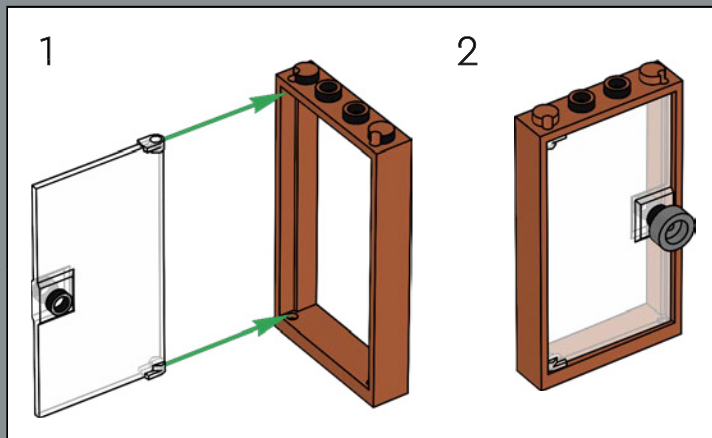

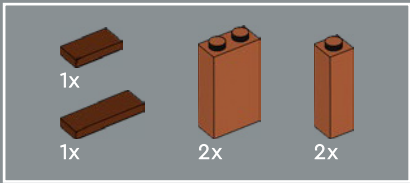

59

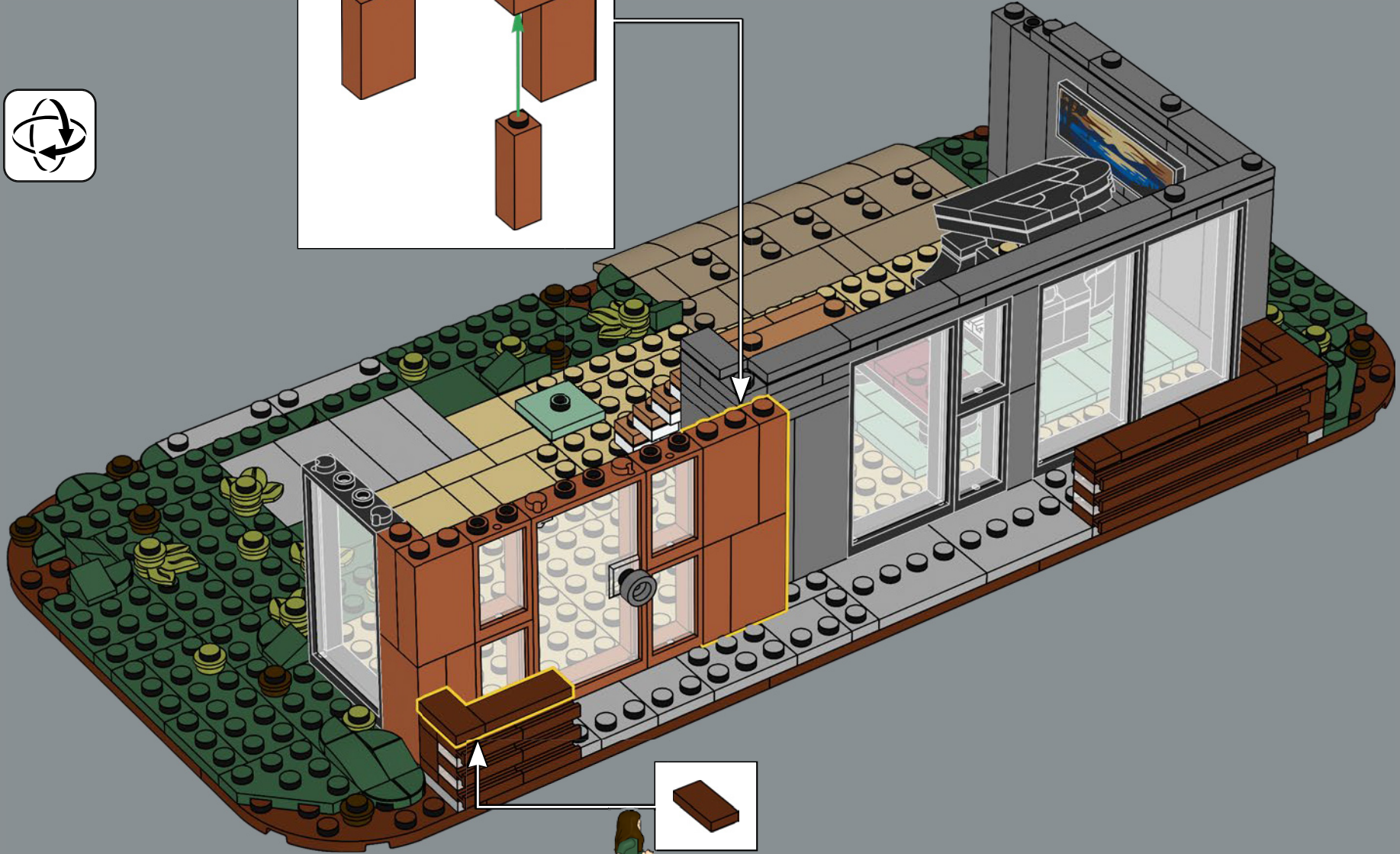
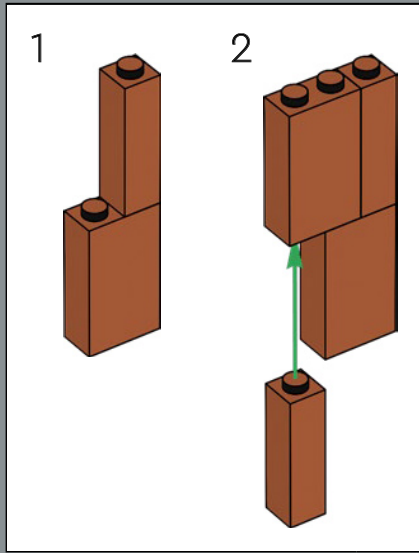

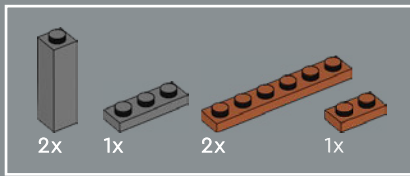

60

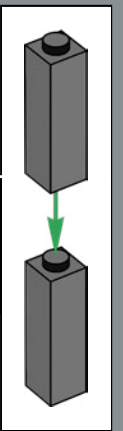

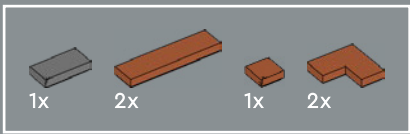

61



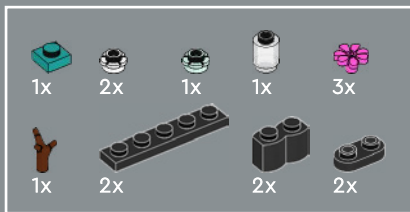

62

1

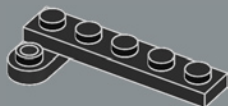

2

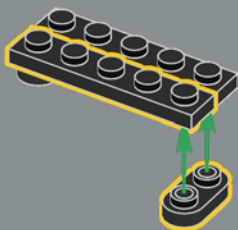

3

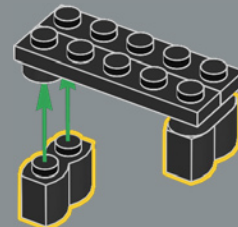

4

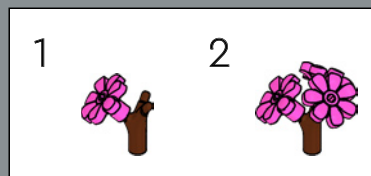
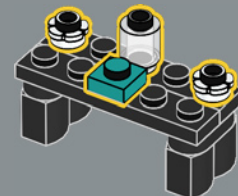

5

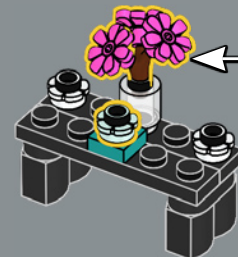



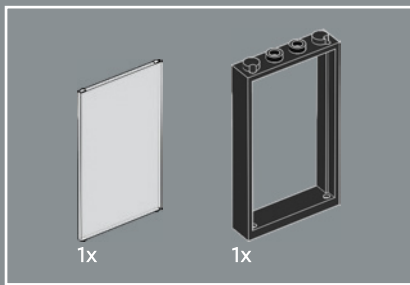

63



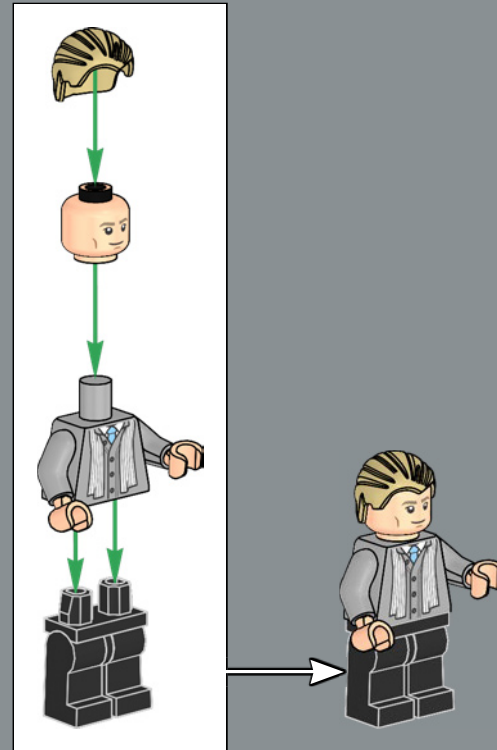

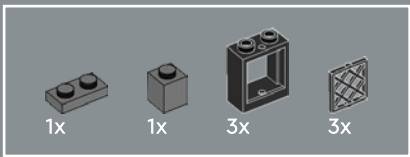

65

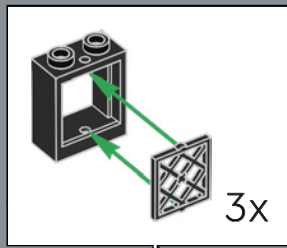

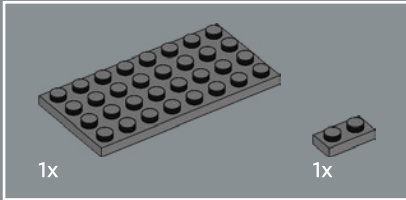
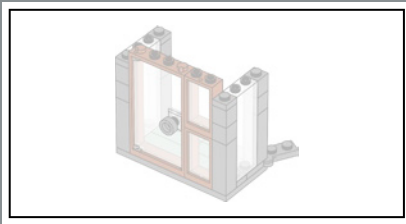

66

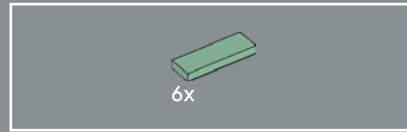
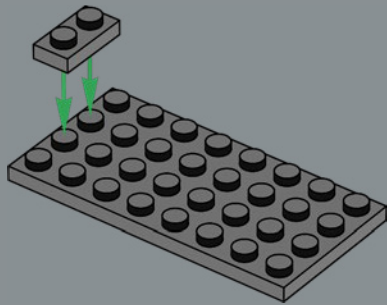

67

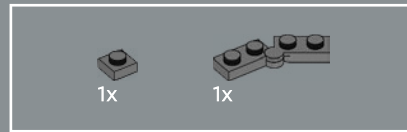
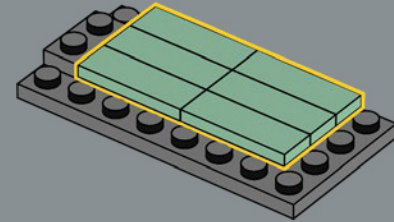

68

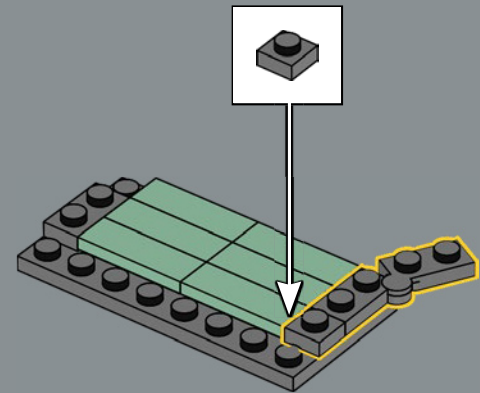

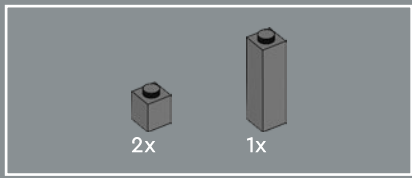

69

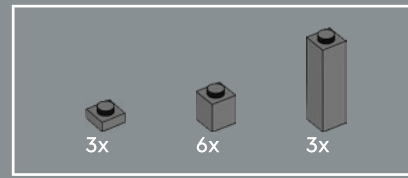
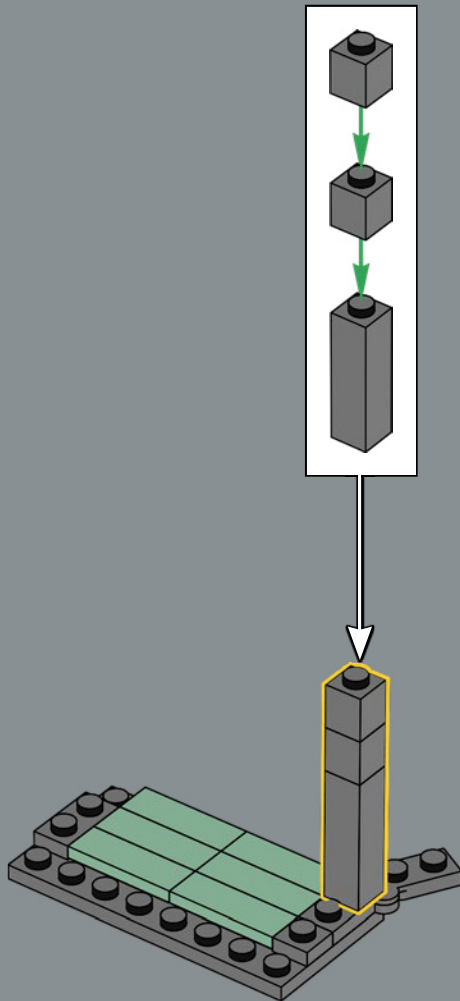

70

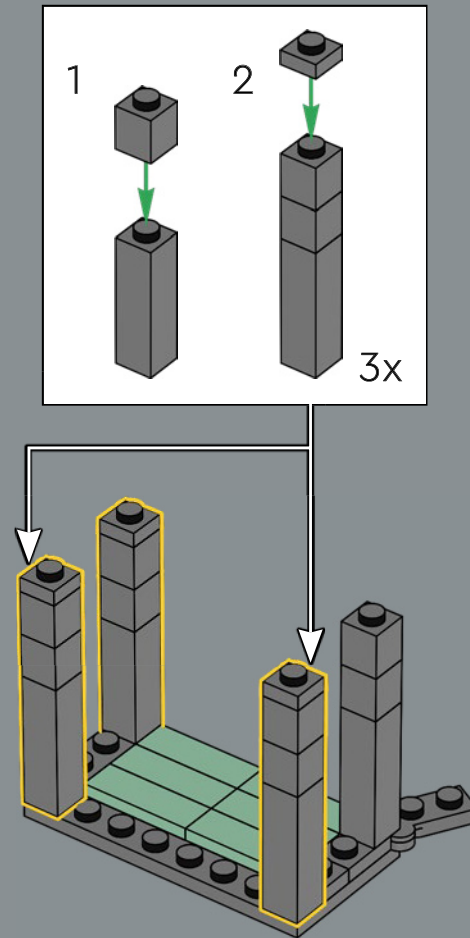

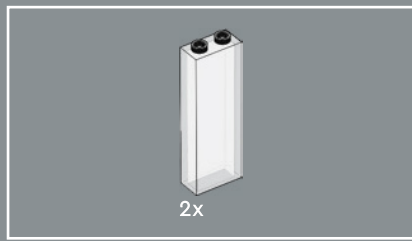

71

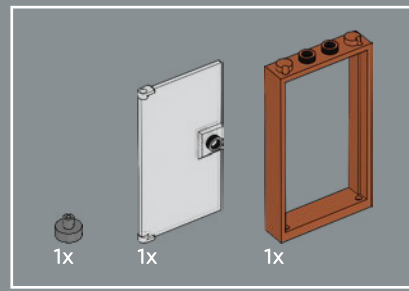
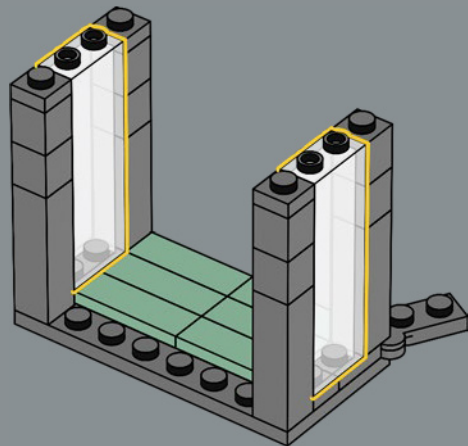

72

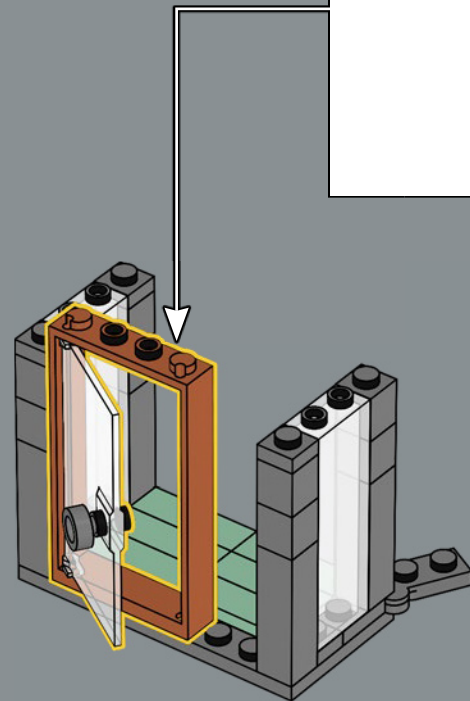
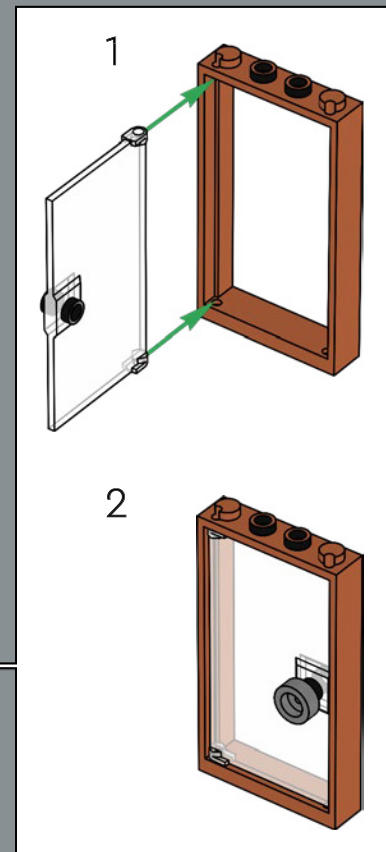

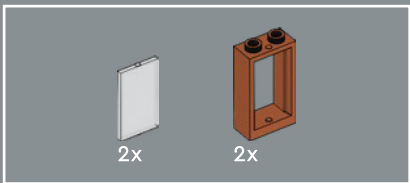

73

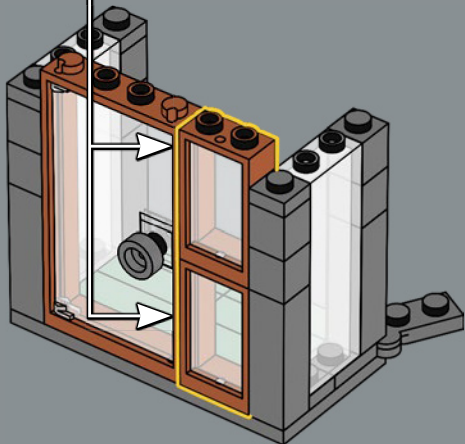
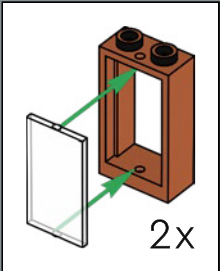

74

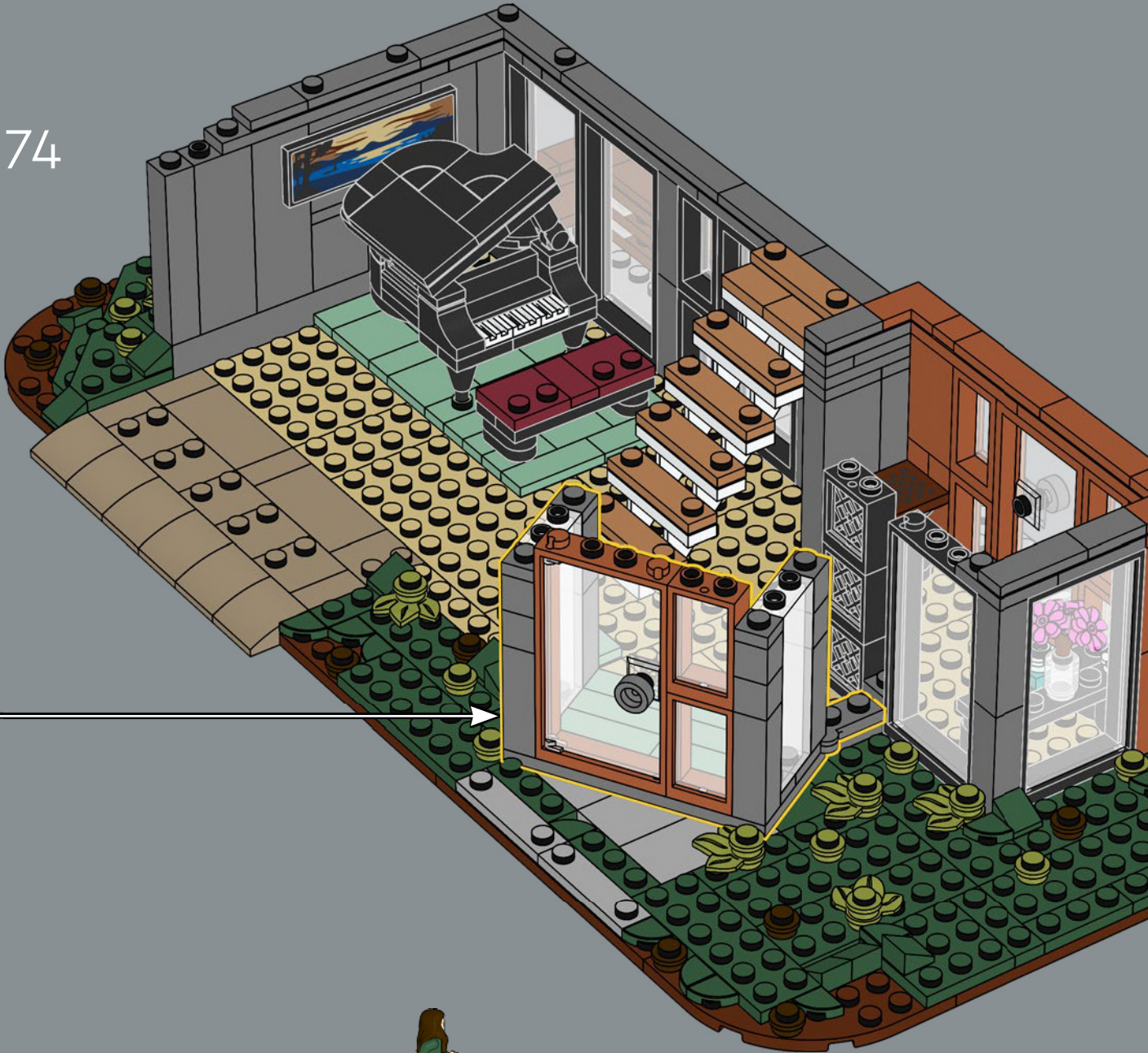

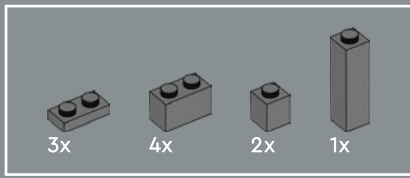

75

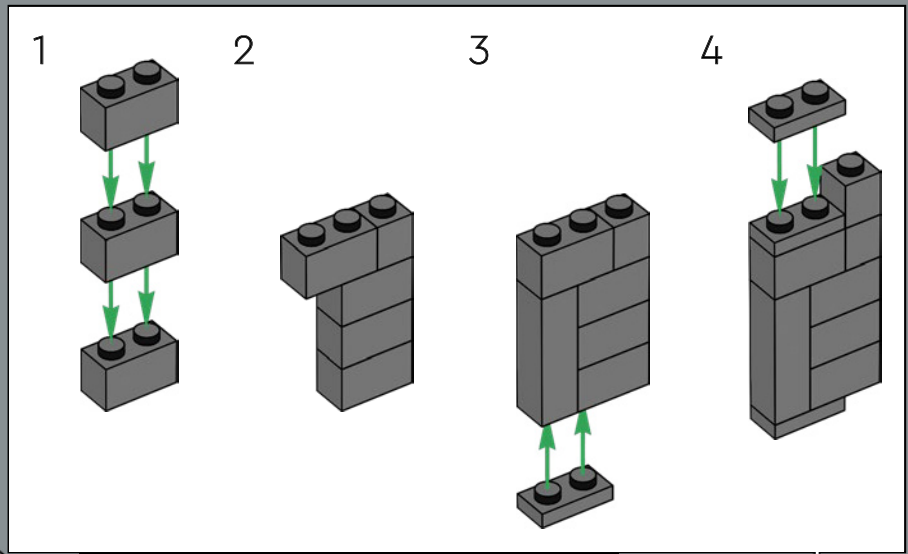

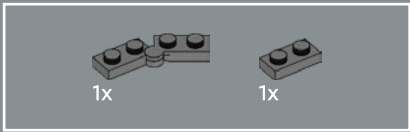

76

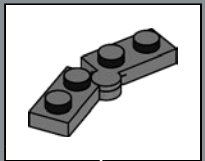
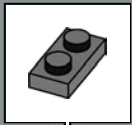
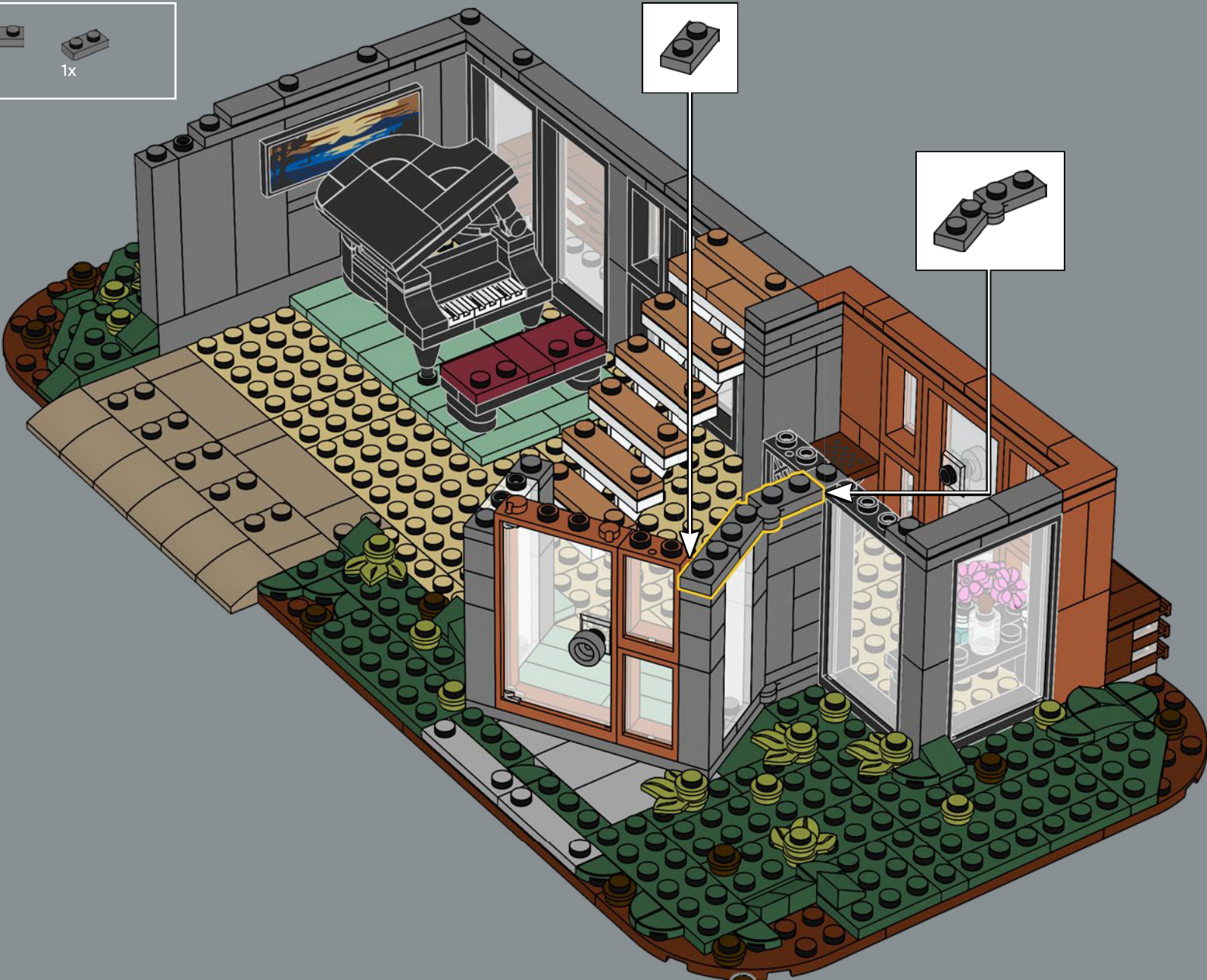

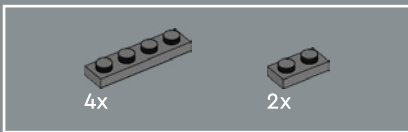

77

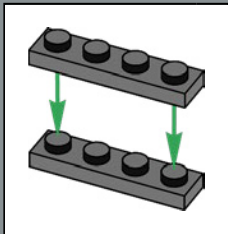
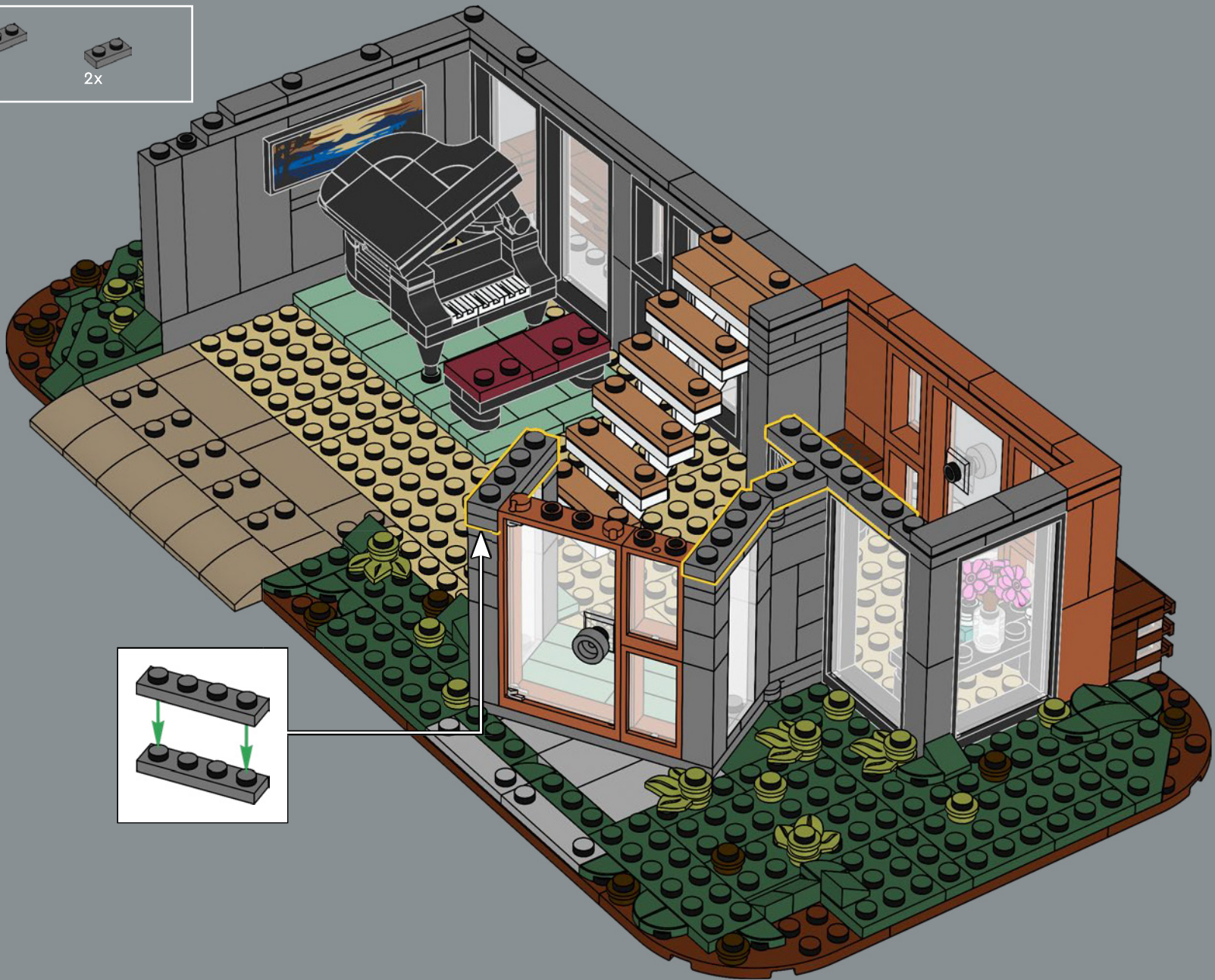

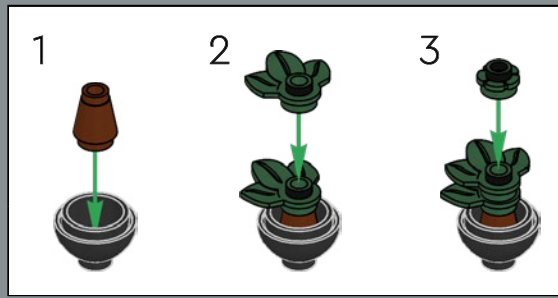
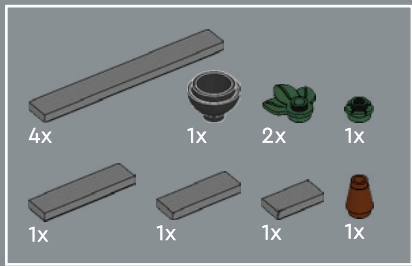

78



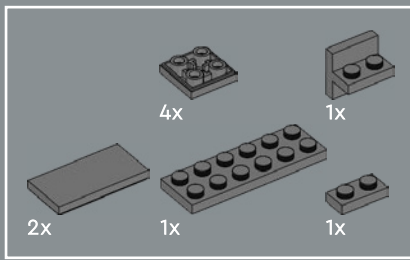

79

1

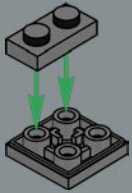

2

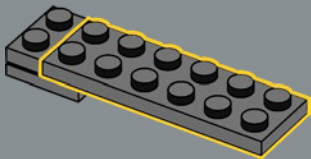

3

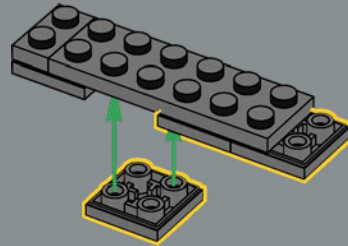

4

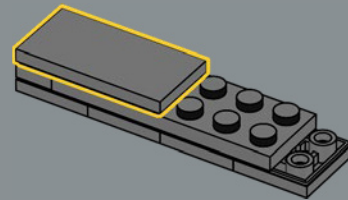

5

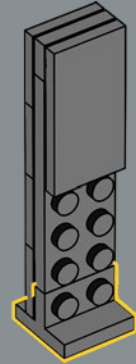

6

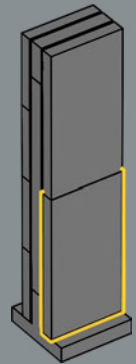



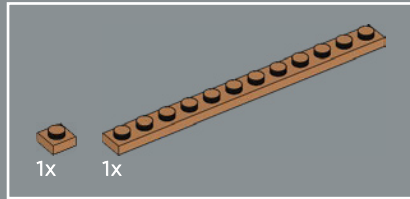
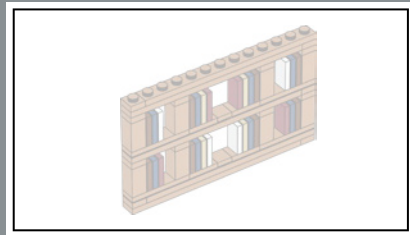

80

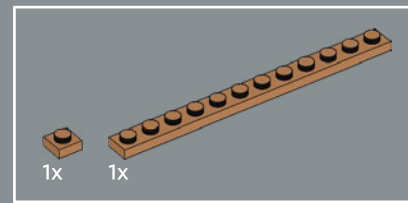
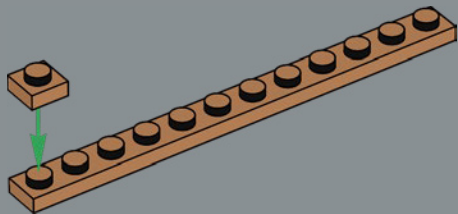

81

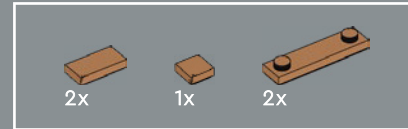
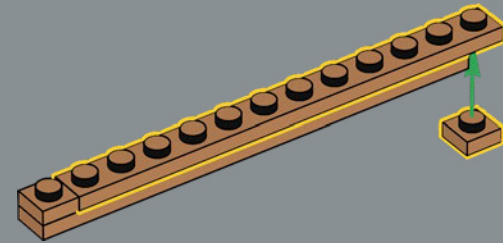

82

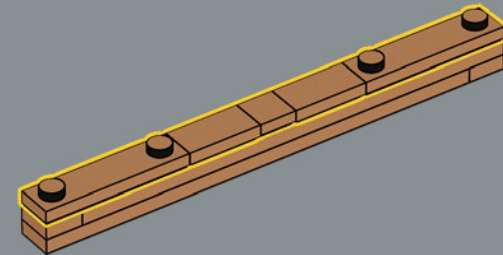

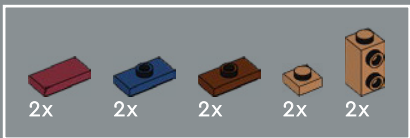

83

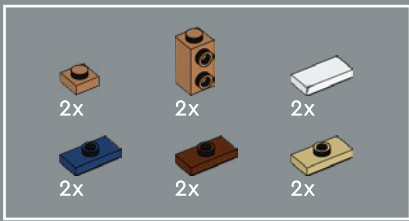
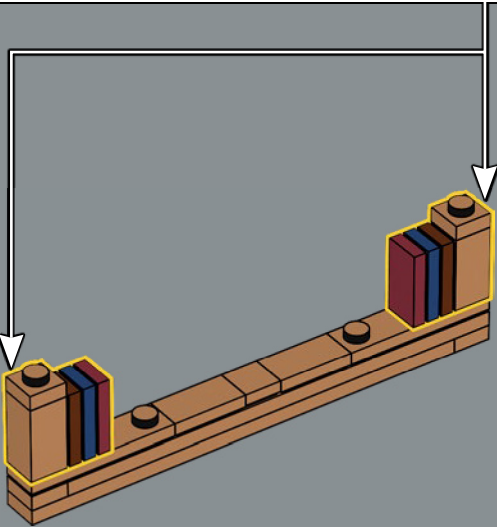
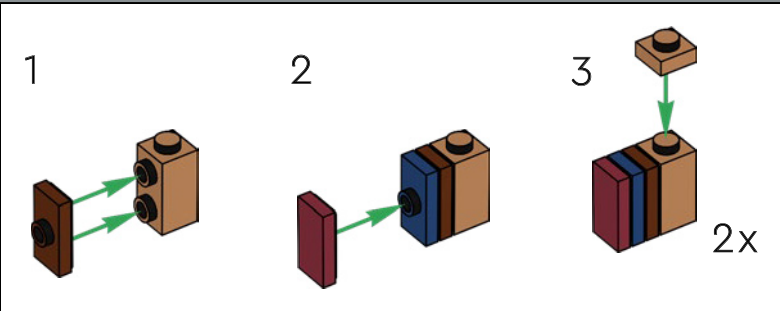

84

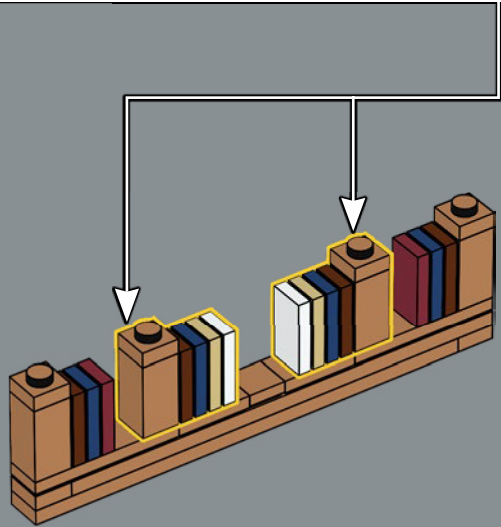
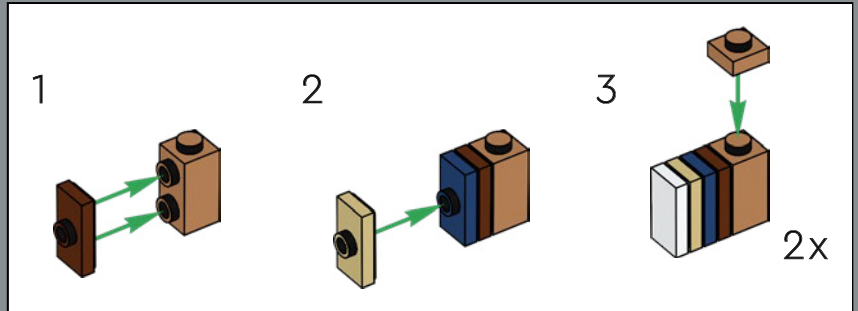

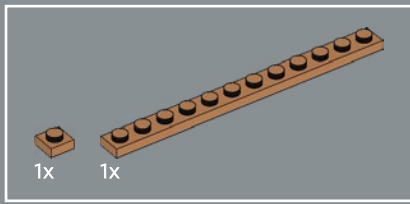

85

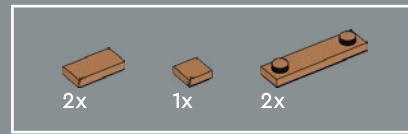
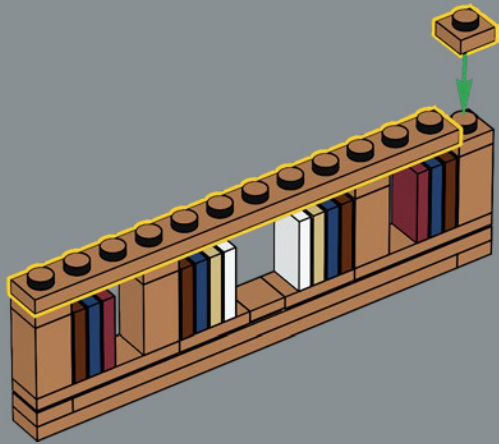

86

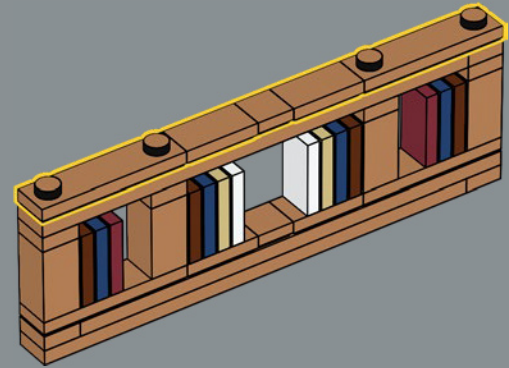

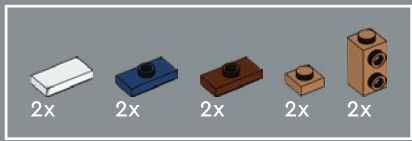

87

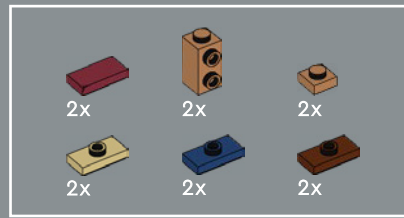
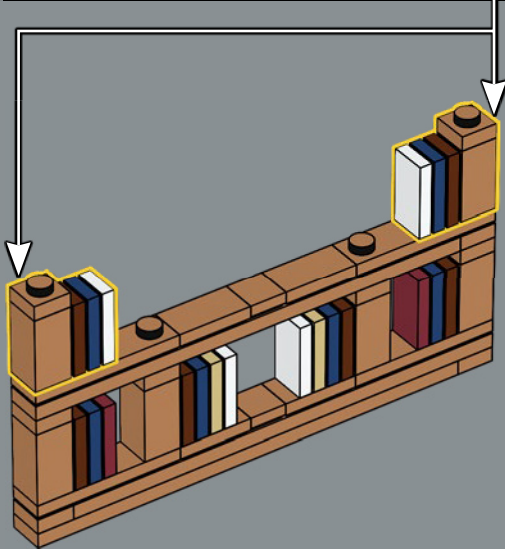
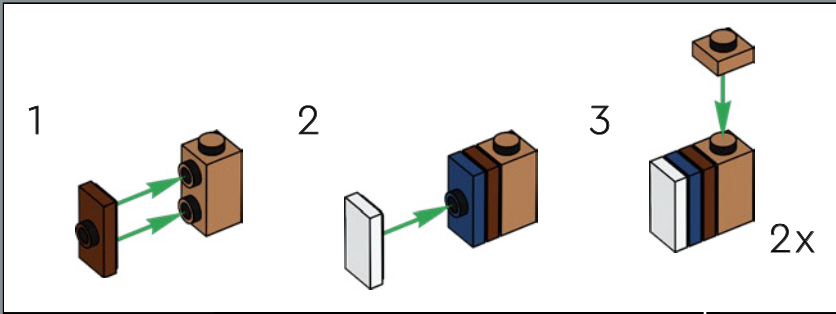

88

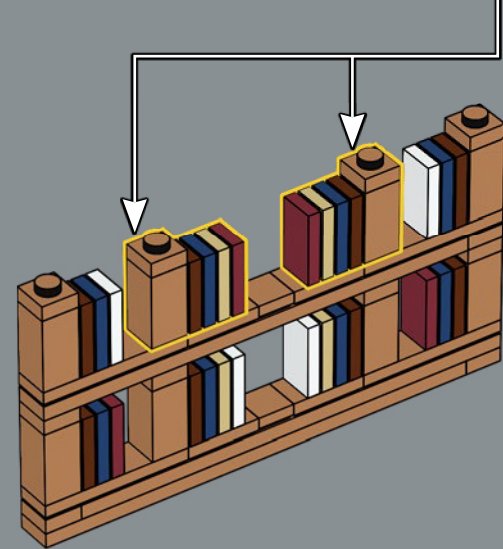
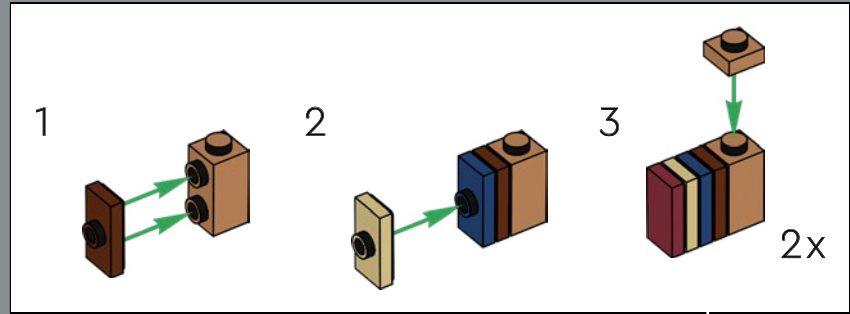

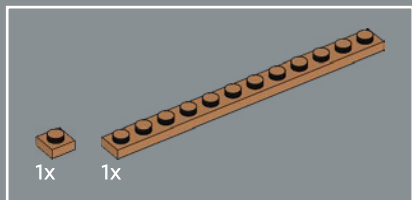

89

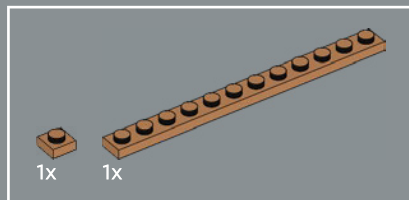
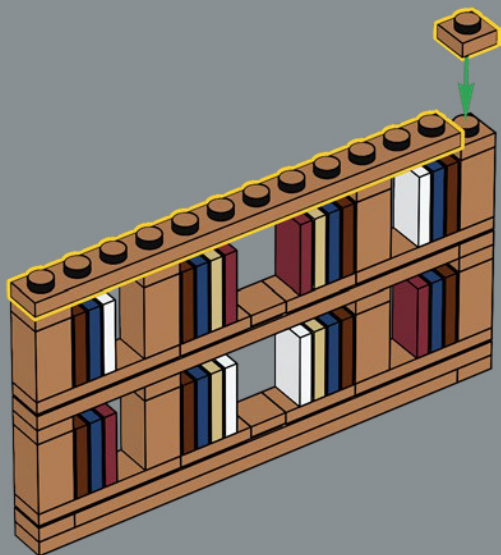

90

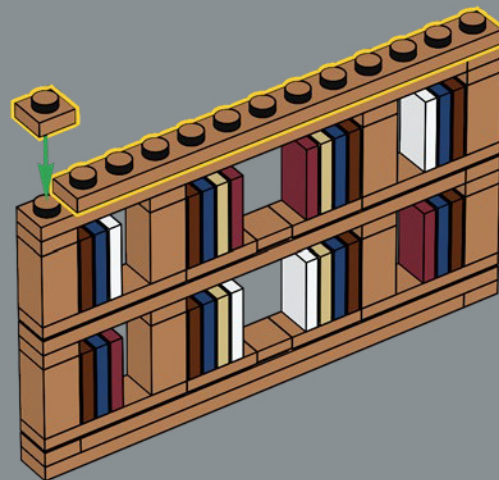



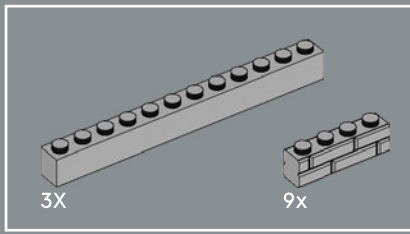

92

1

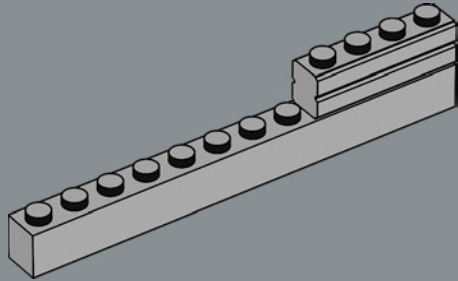

2

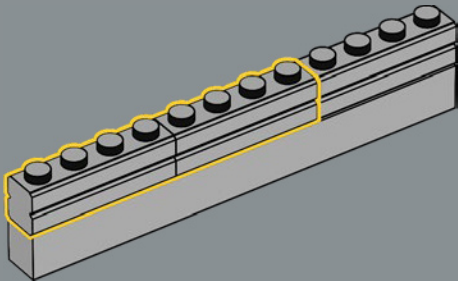

3

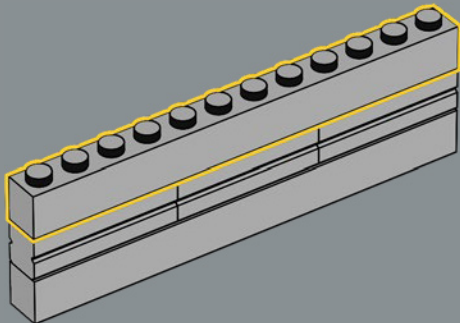

4

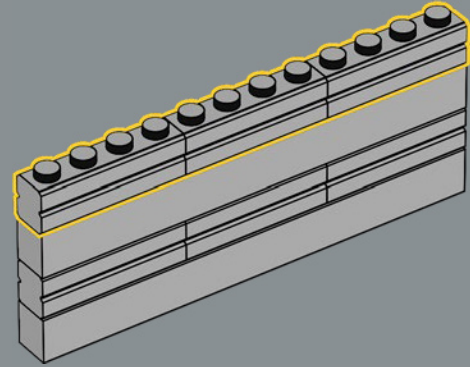

5

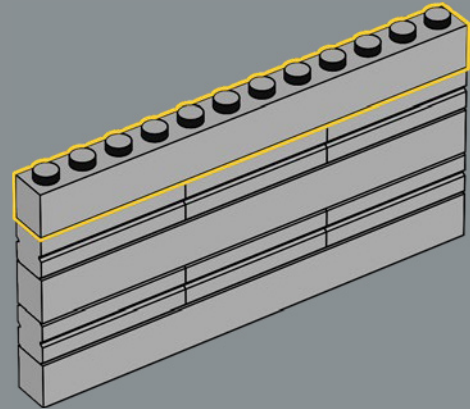

6

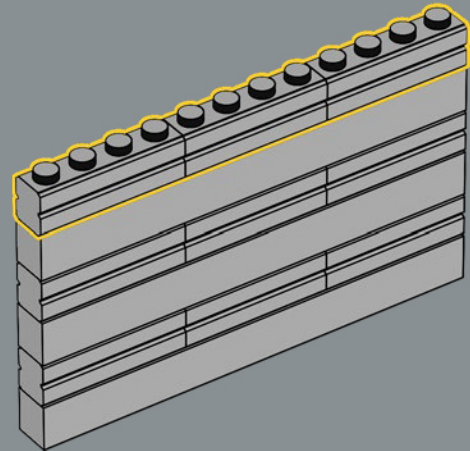

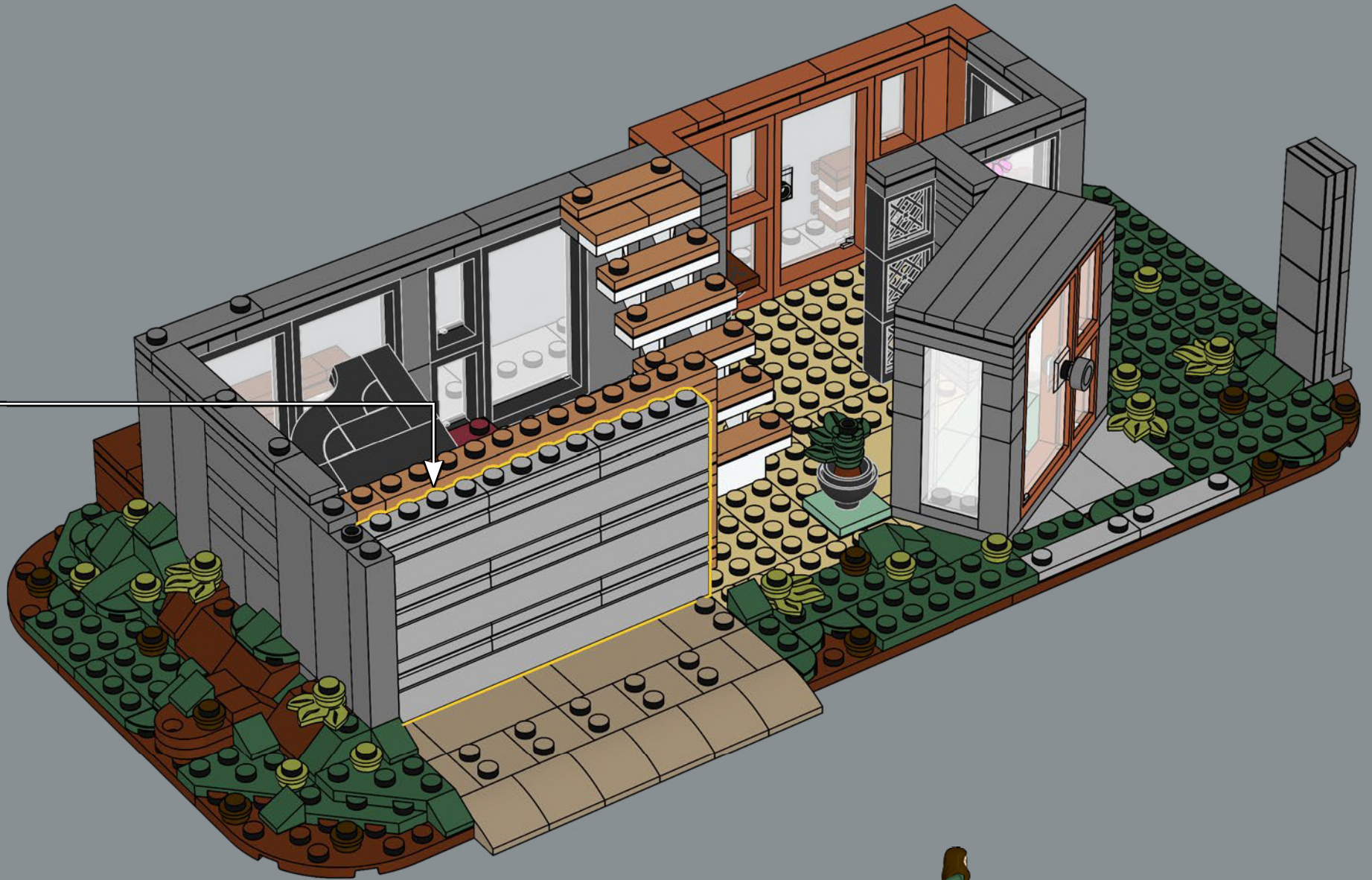

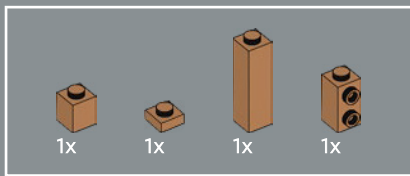

93

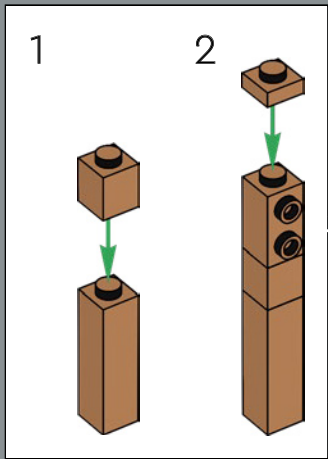

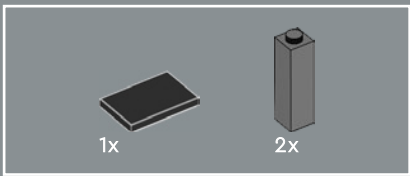

94

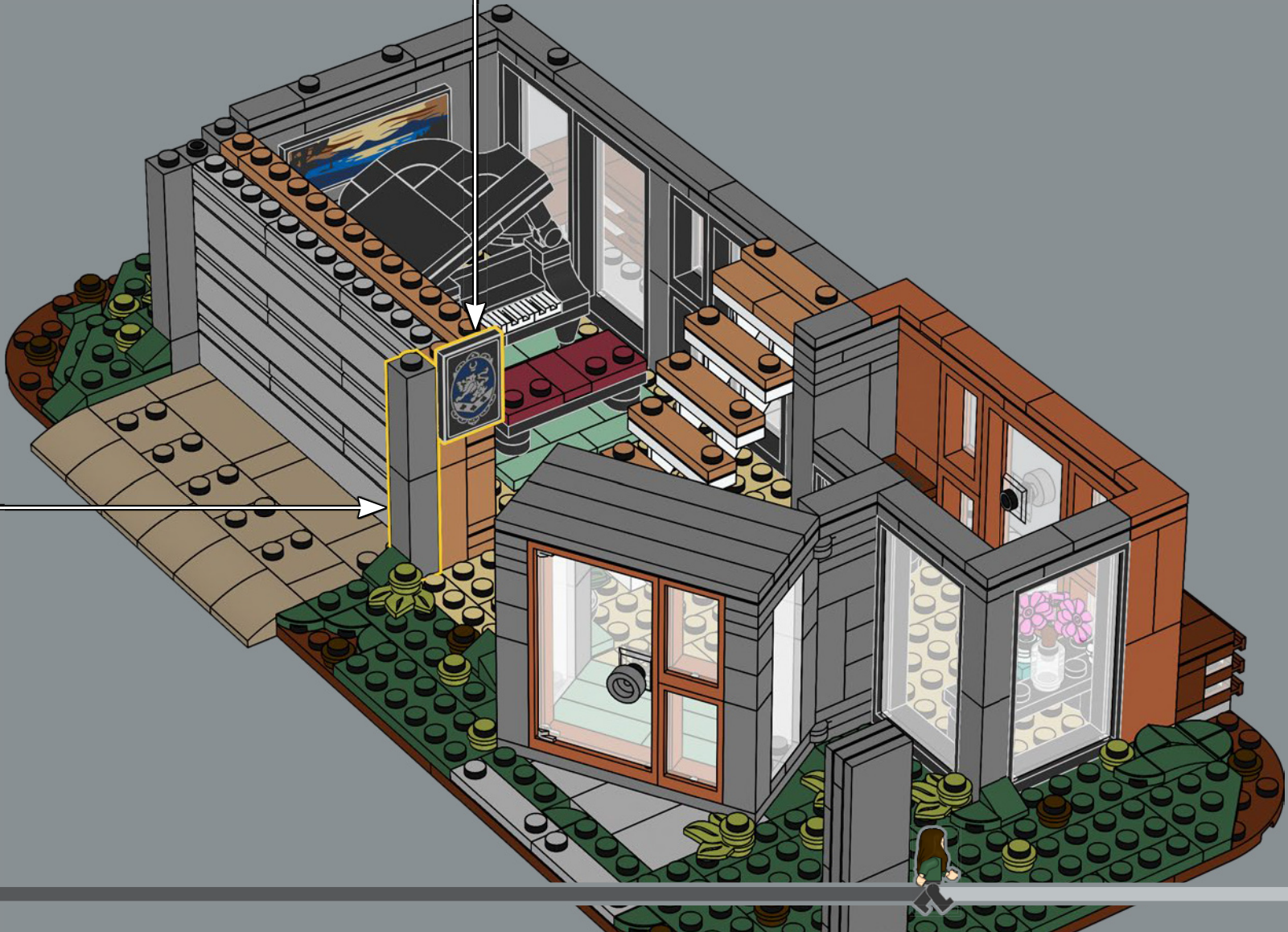
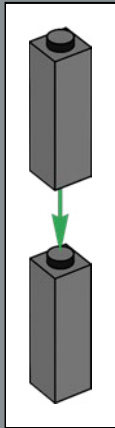

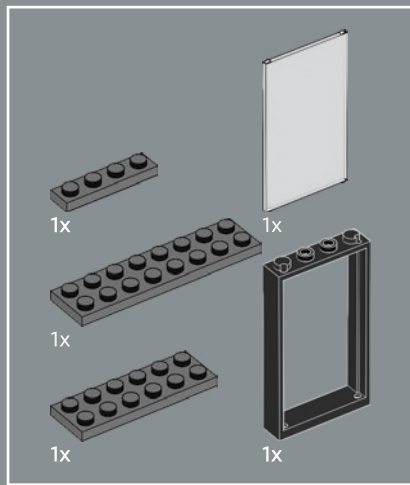

95

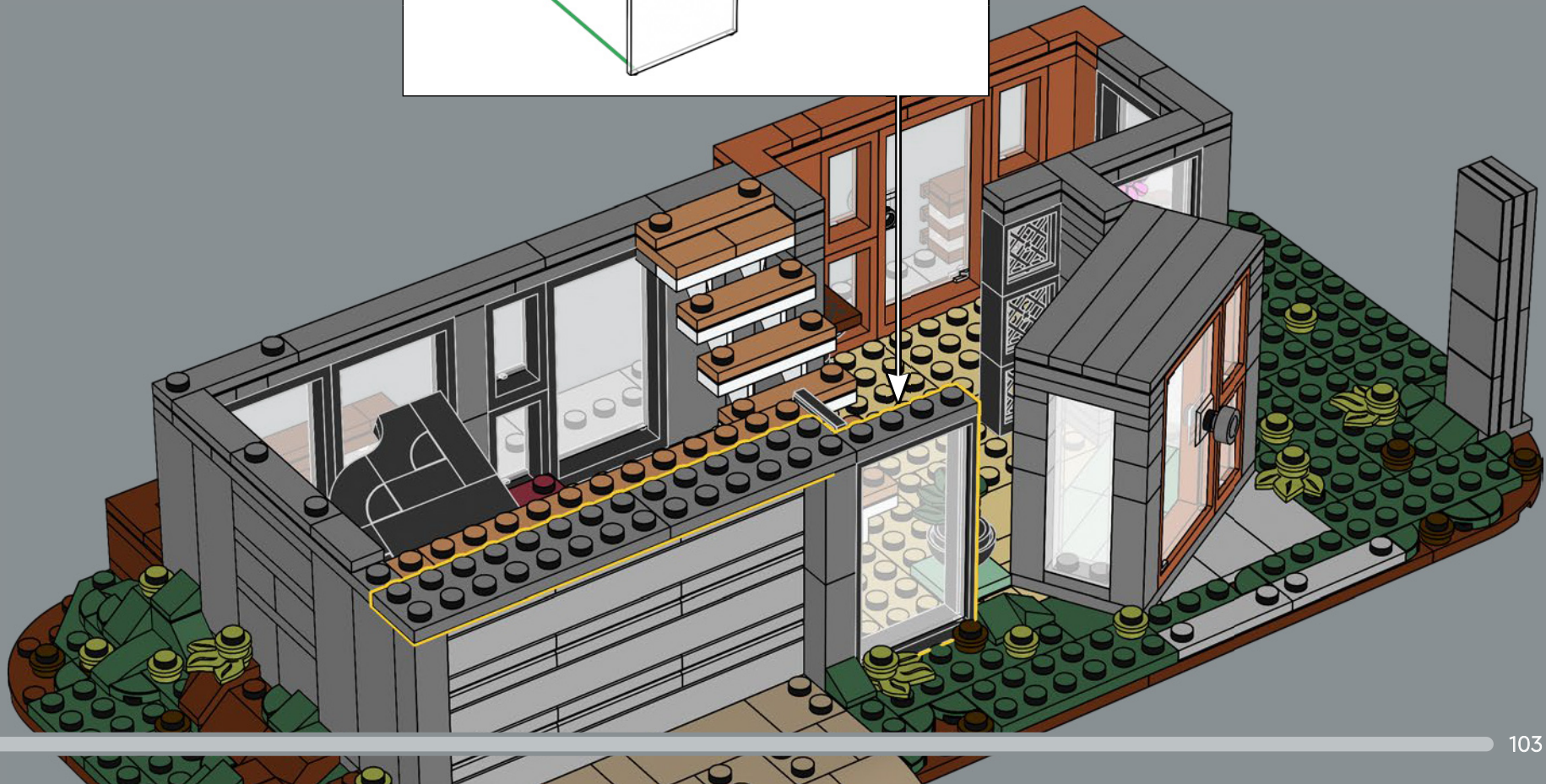
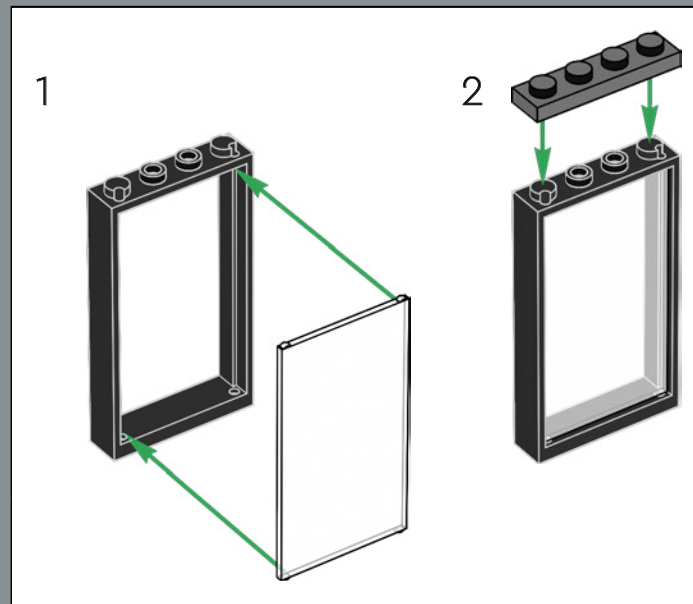

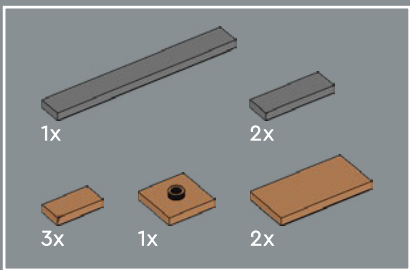

96



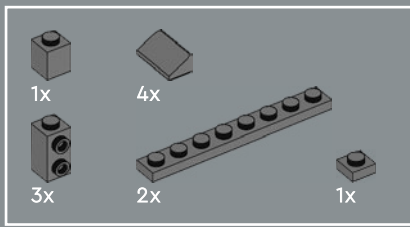

97

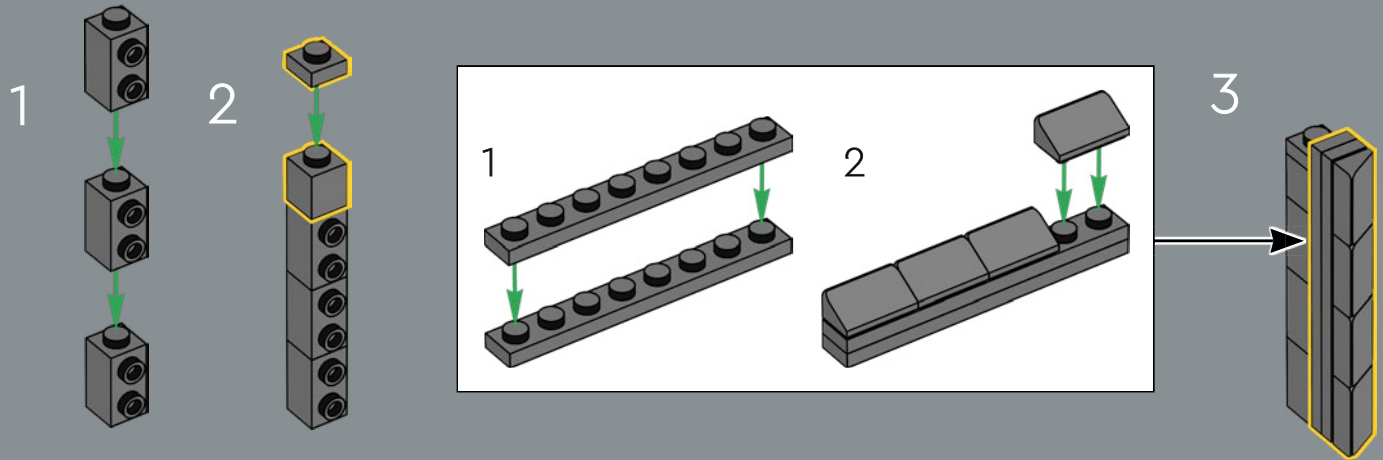

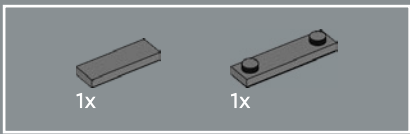

98



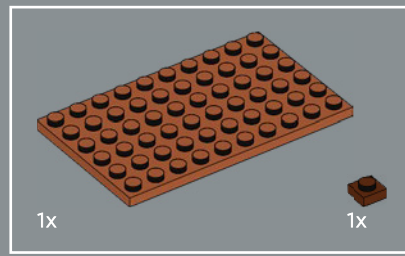

99

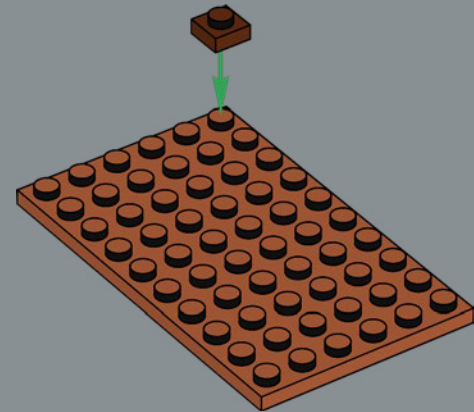
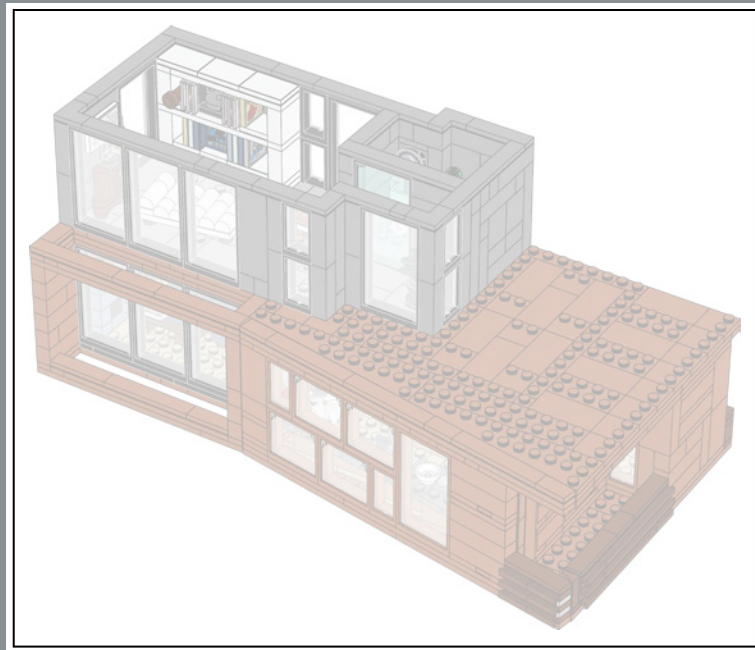

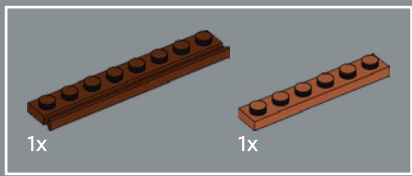

100

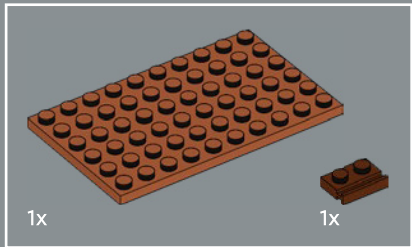
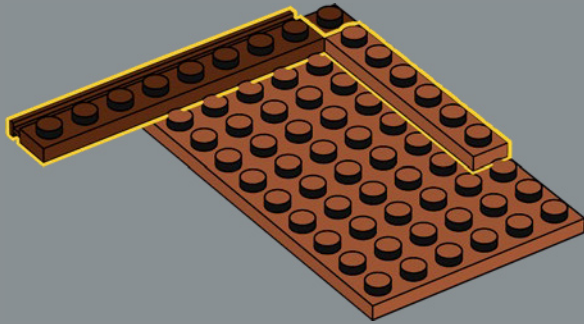

101

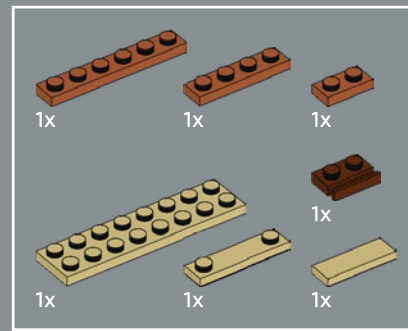
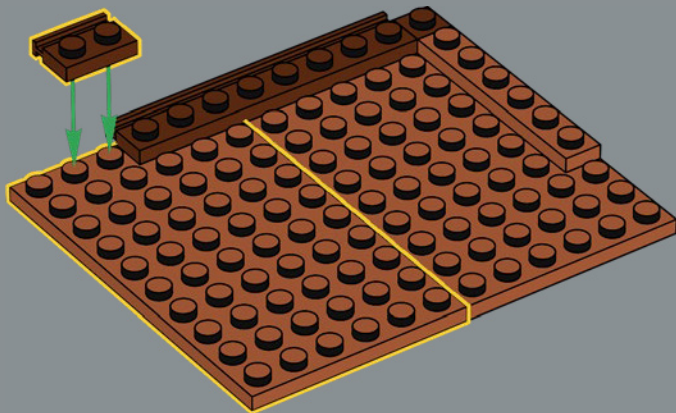

102

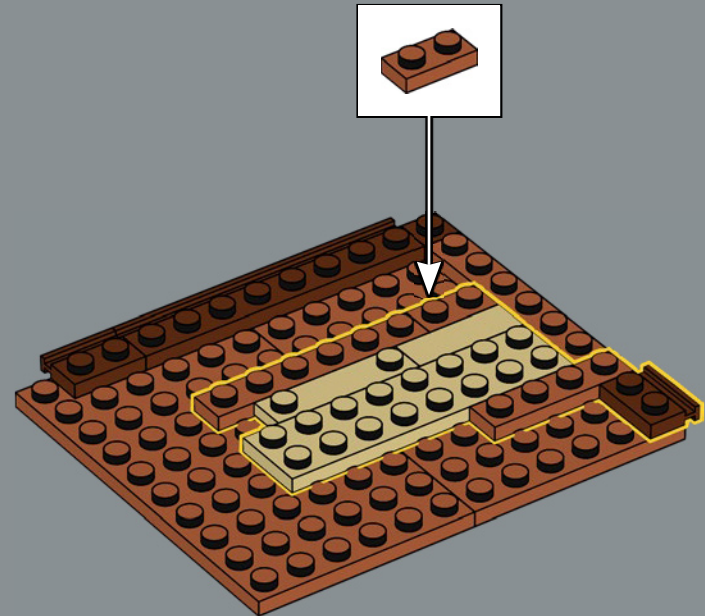

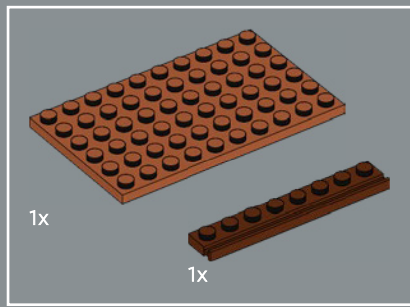

103

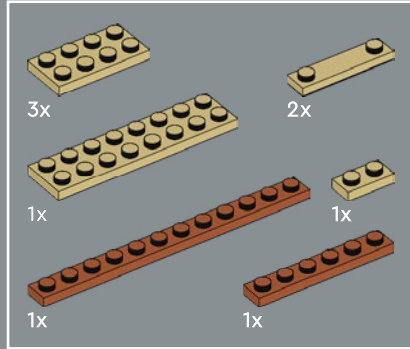
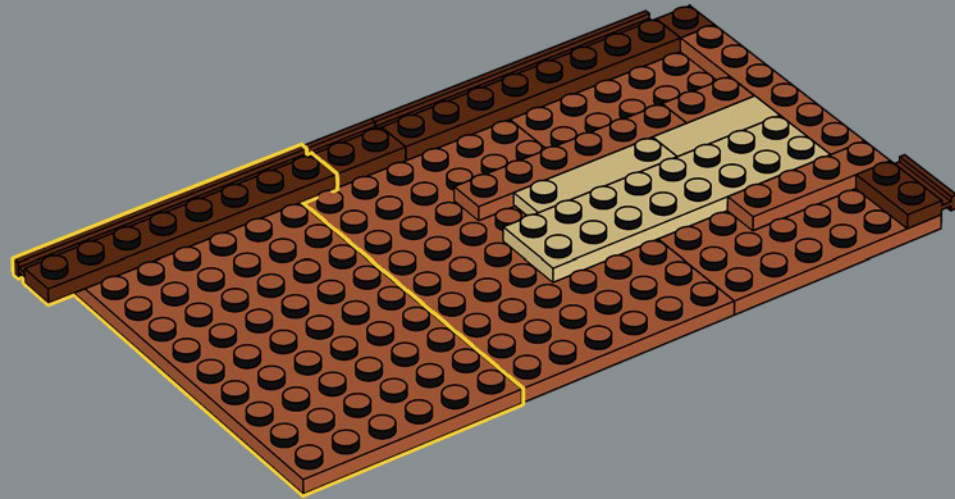

104

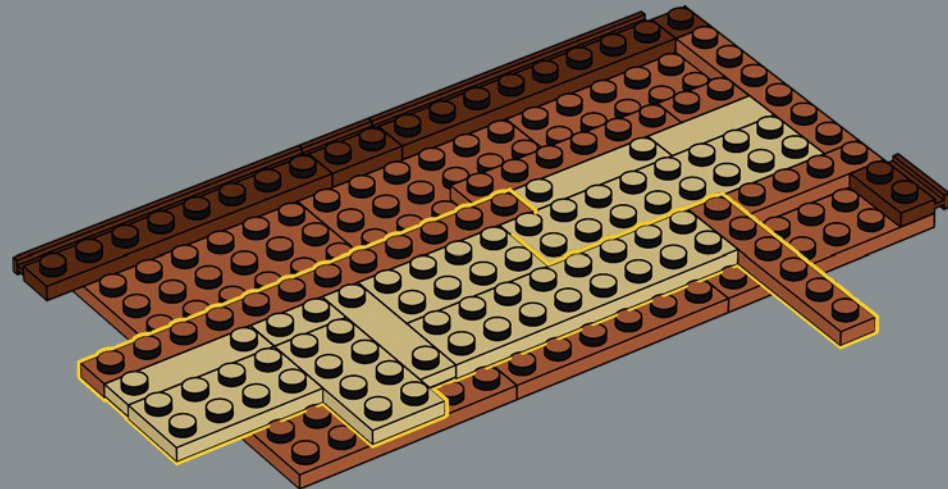

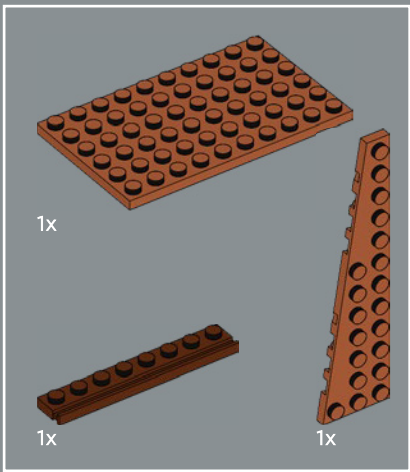

105

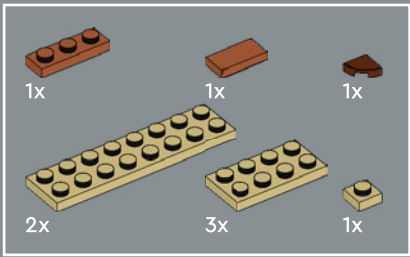
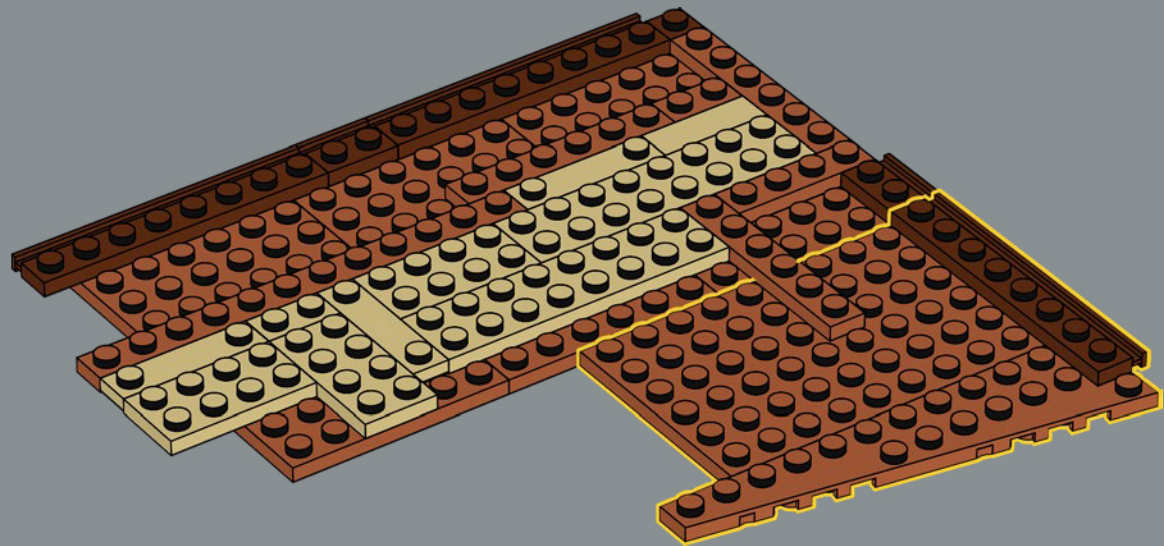

106

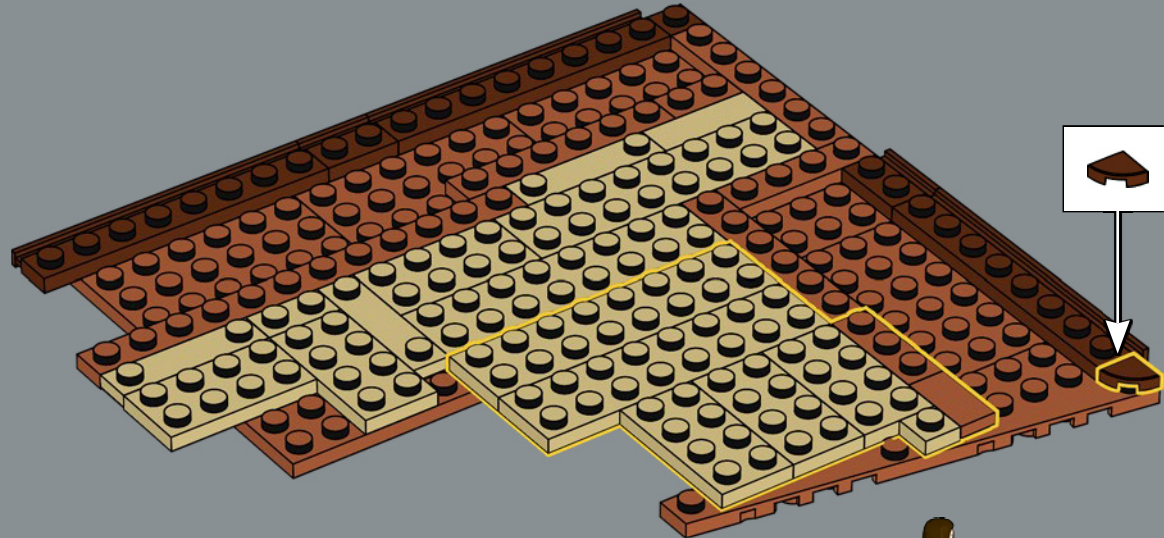

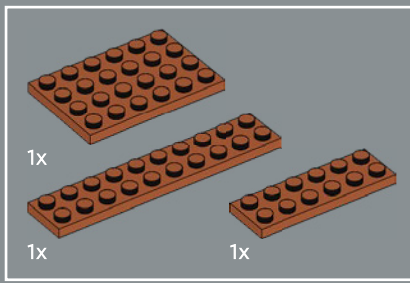

107

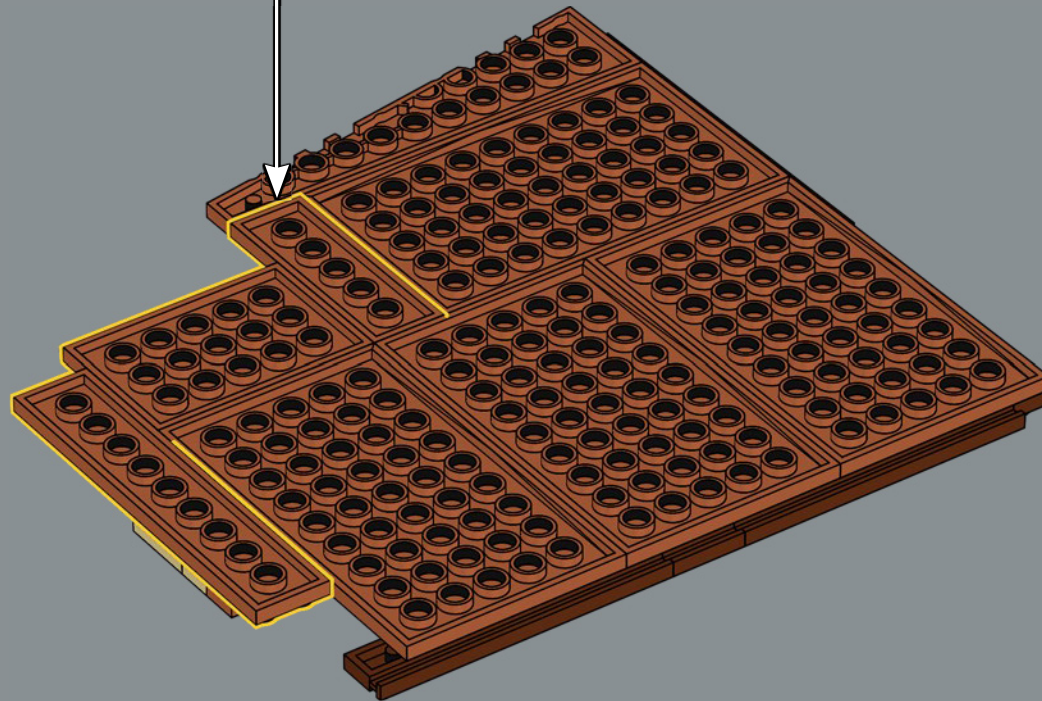
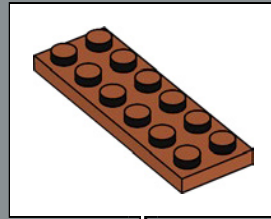

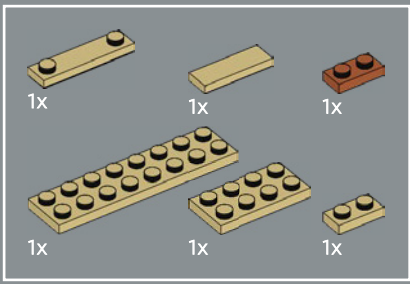

108

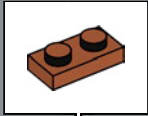

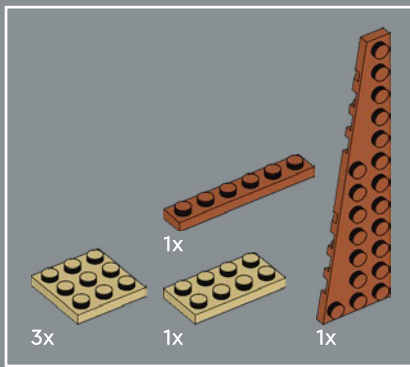

109

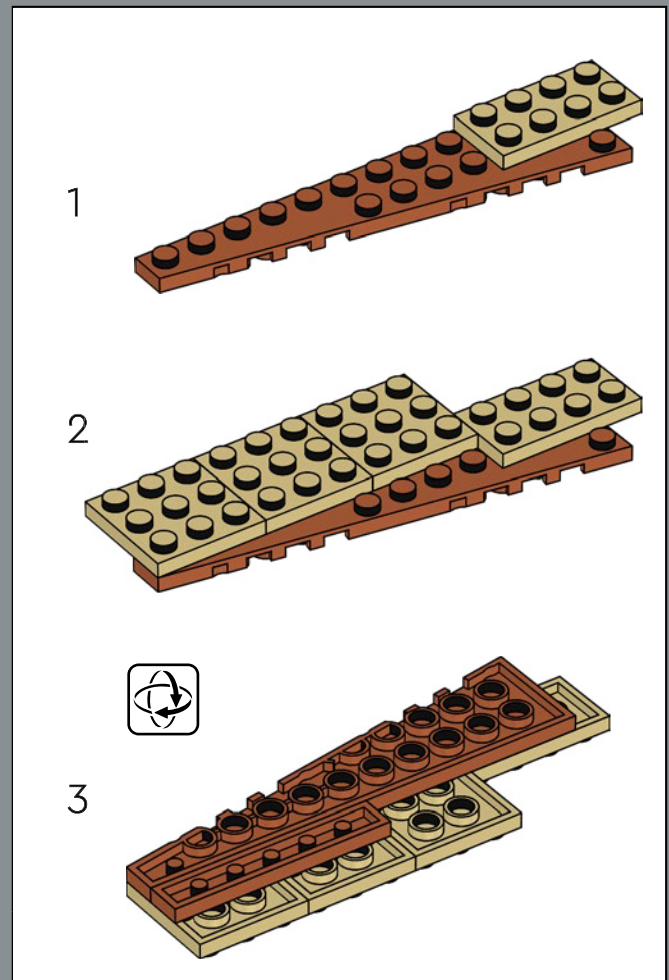
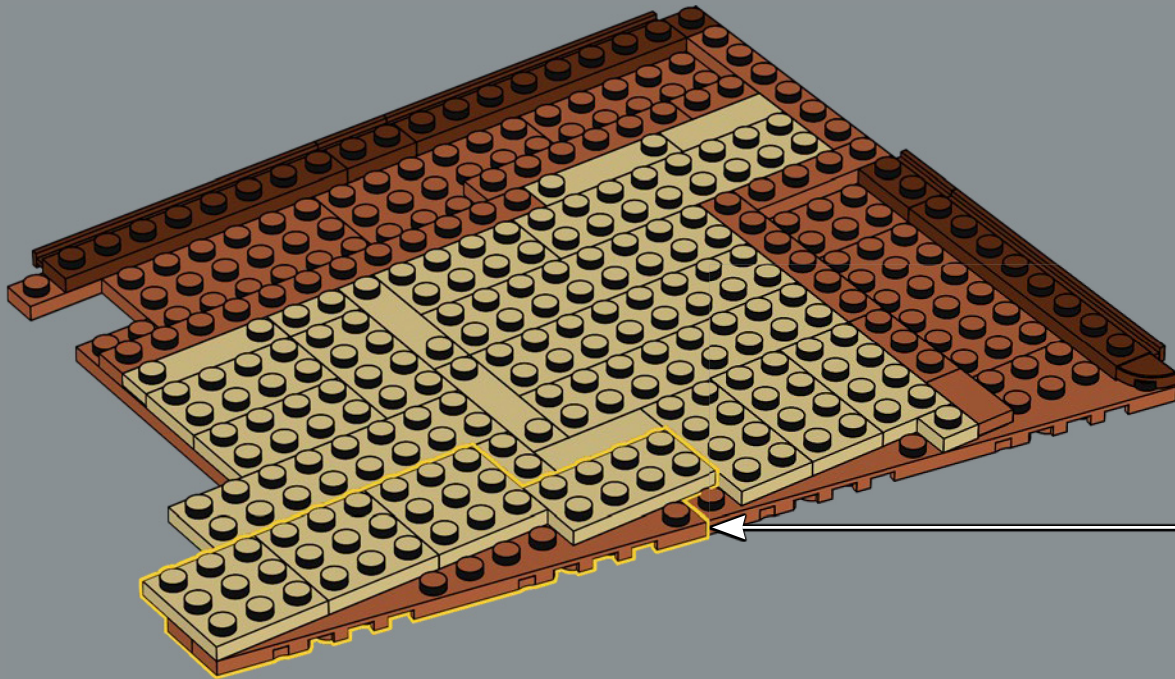

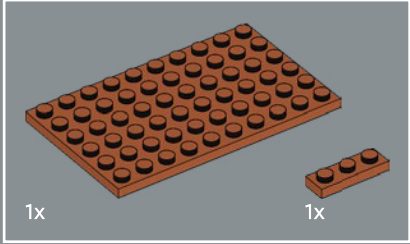
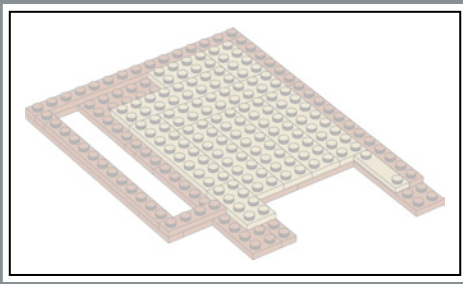

110

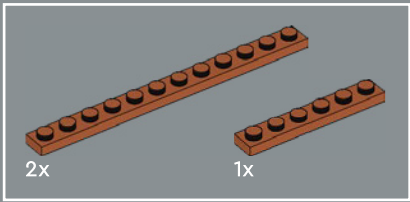
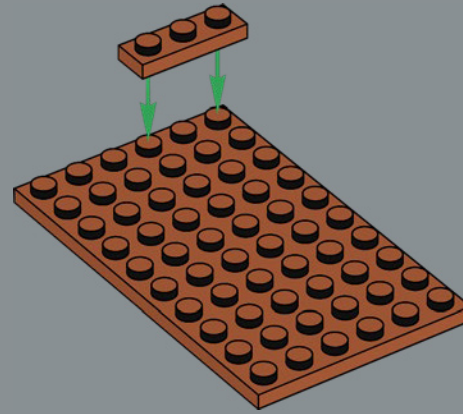

111

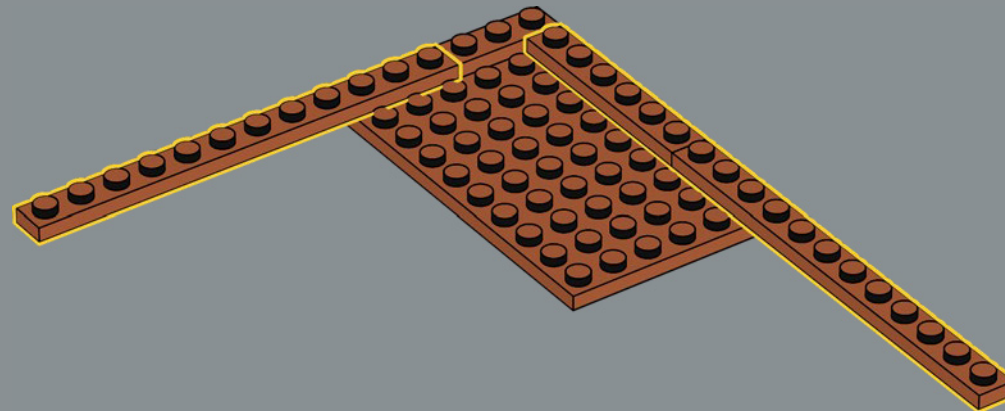

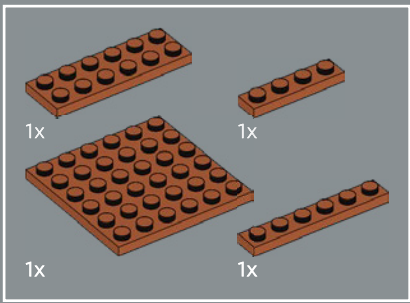

114

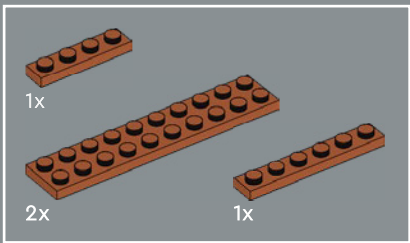
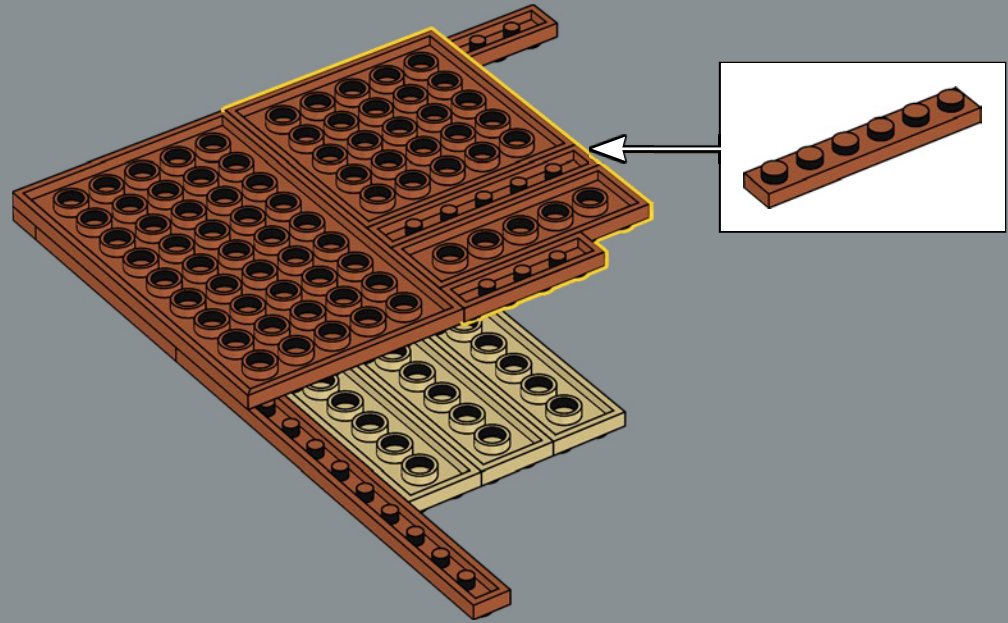

115

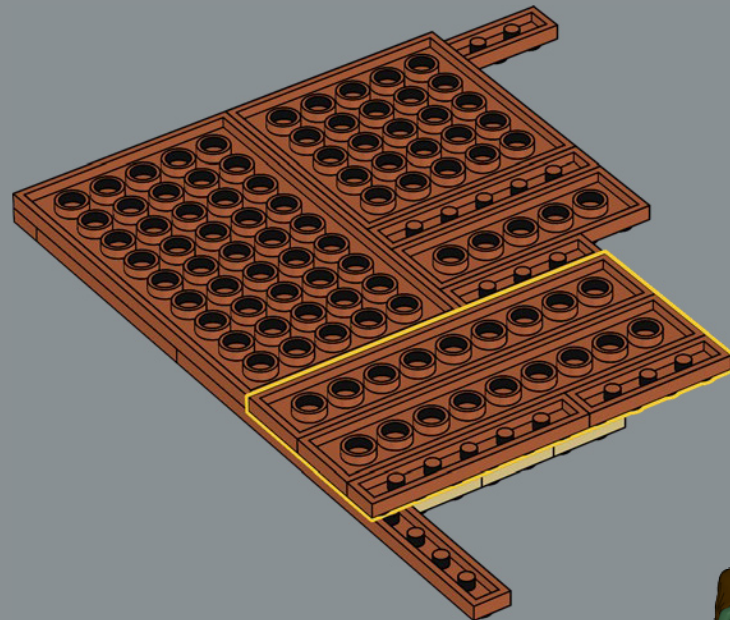

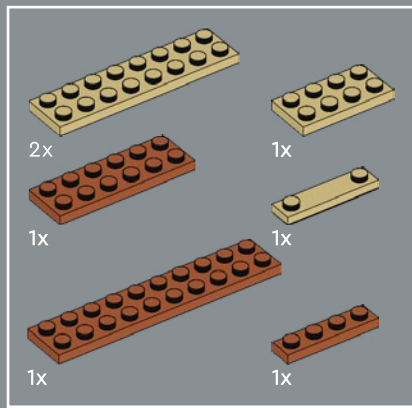

116

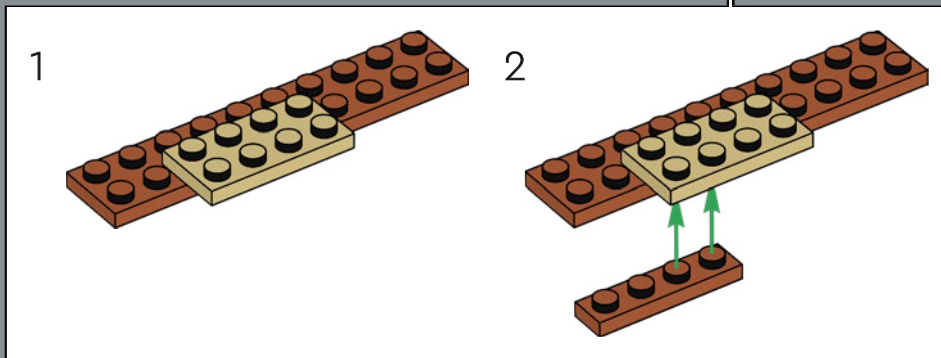
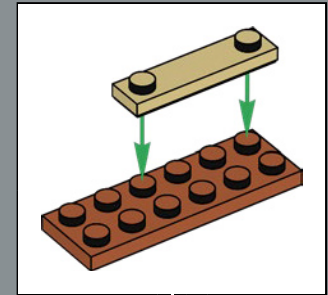
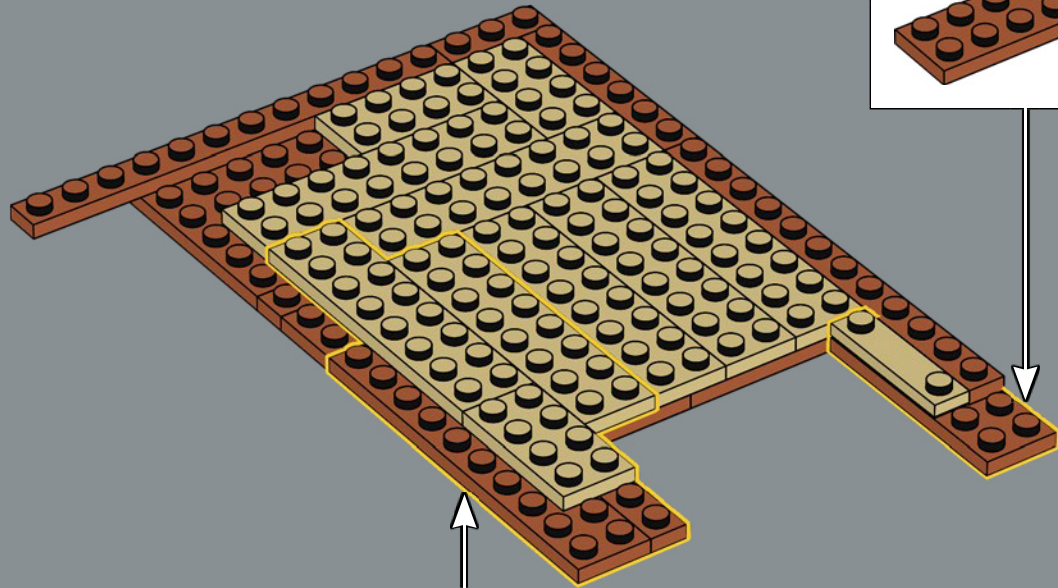

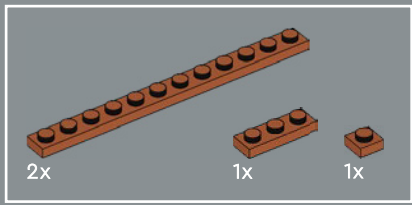

117

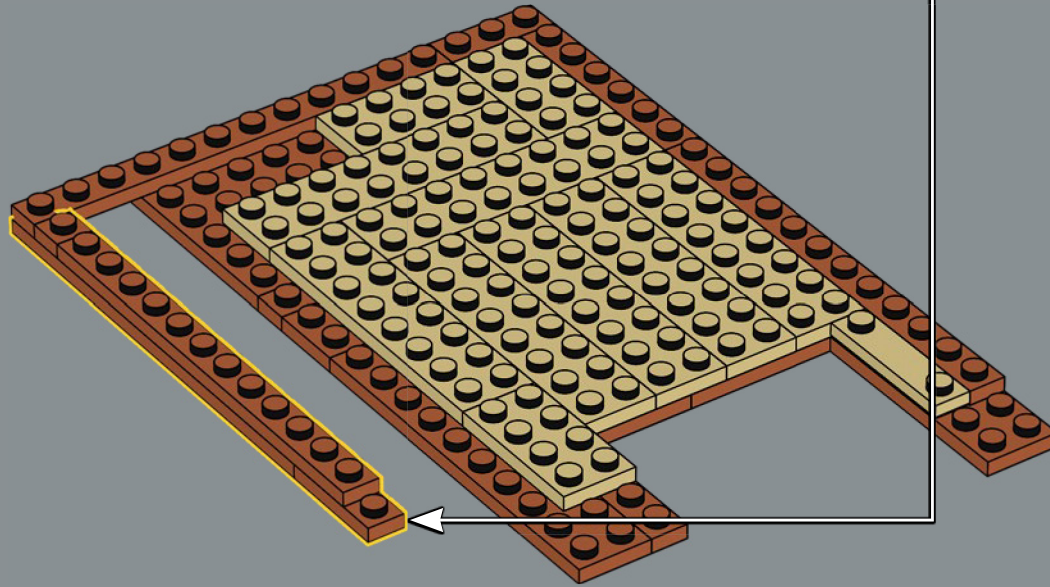
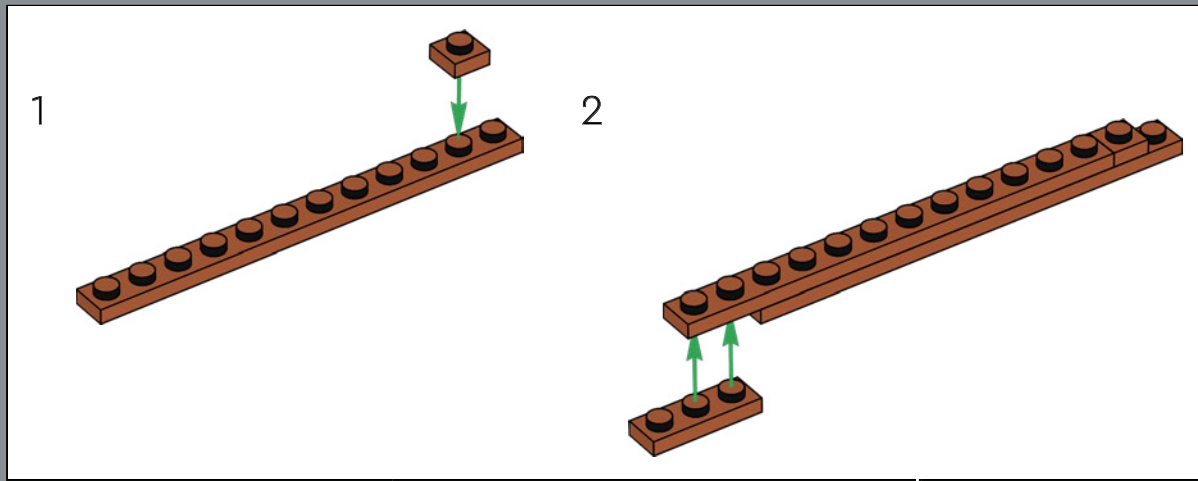

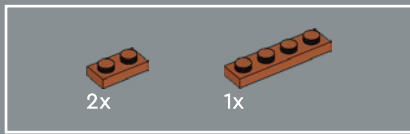

118

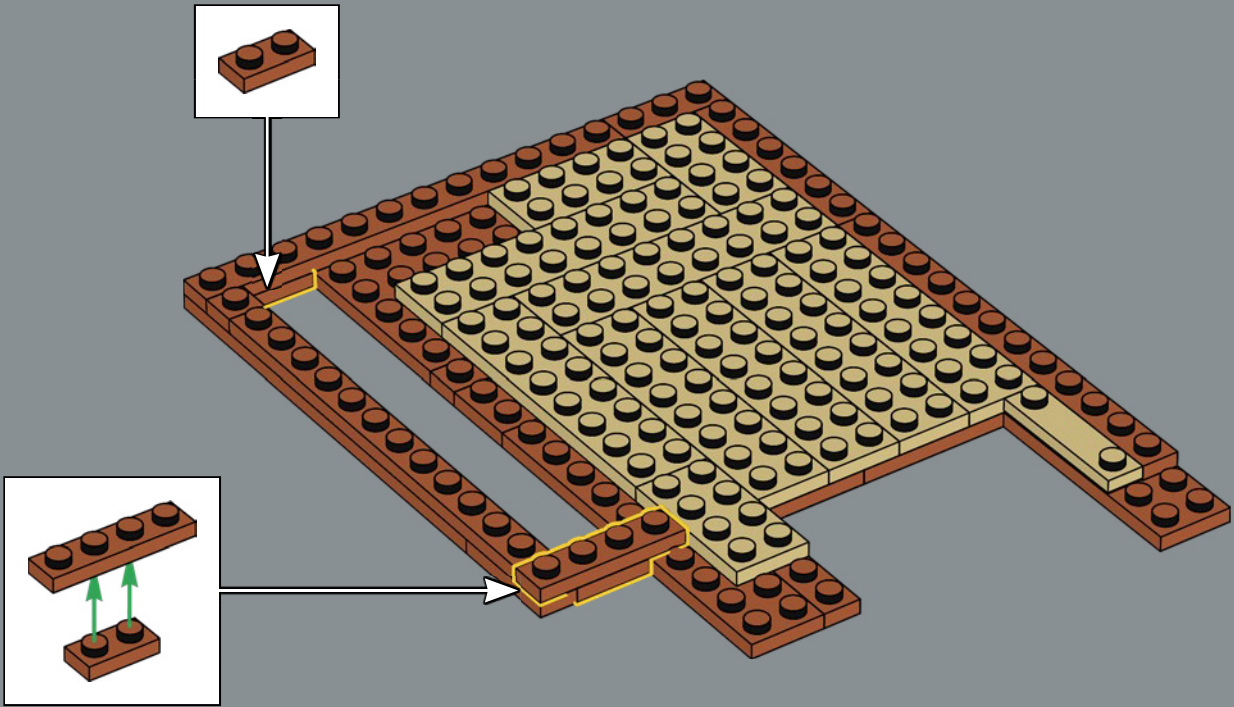

119

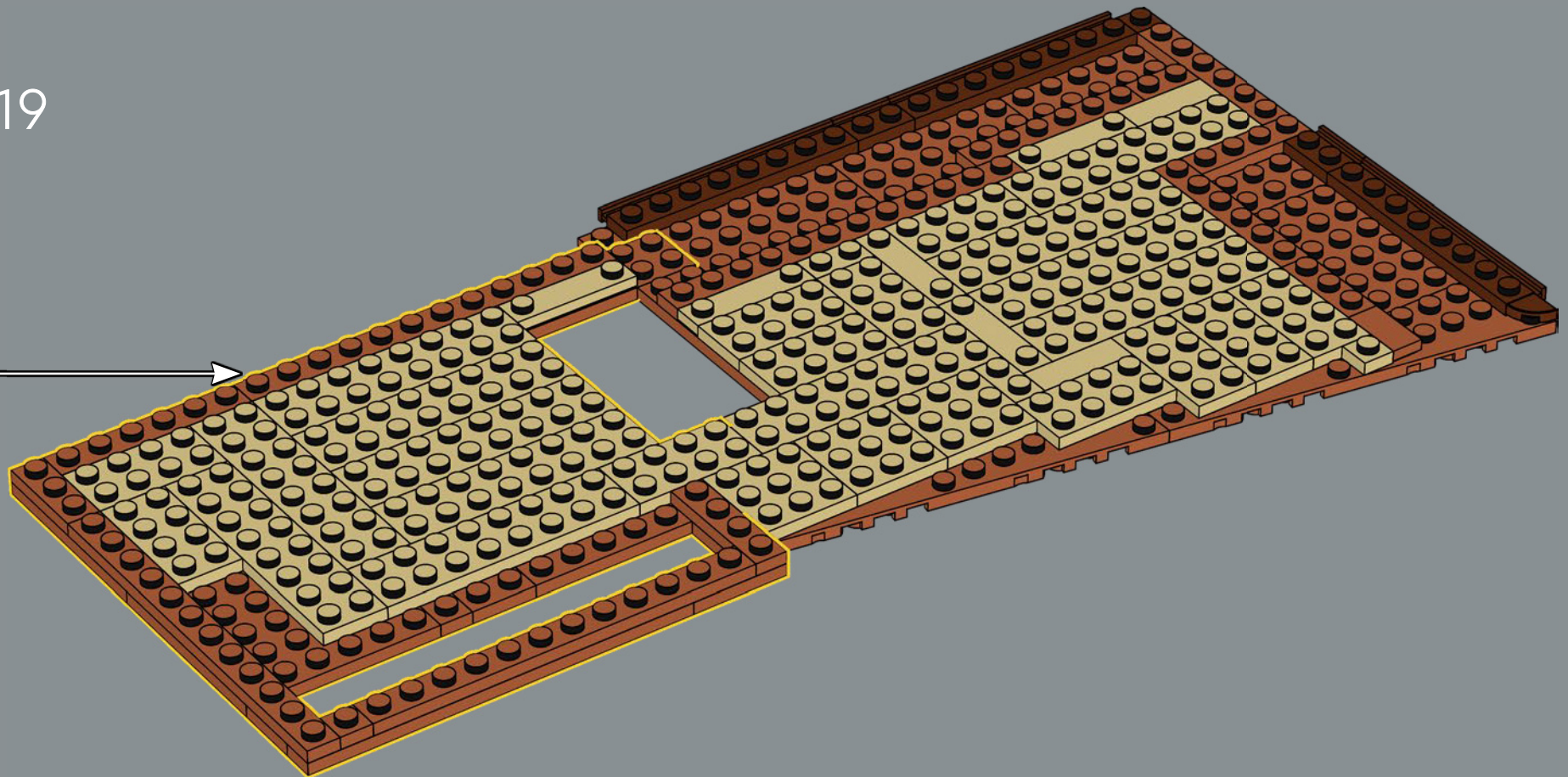

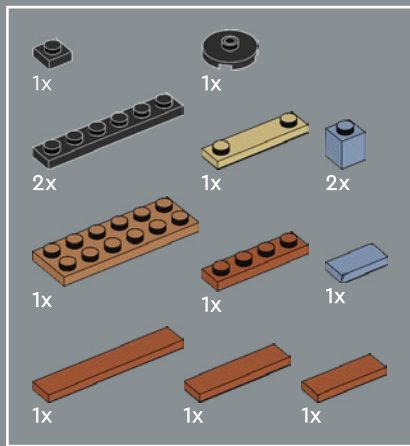

120

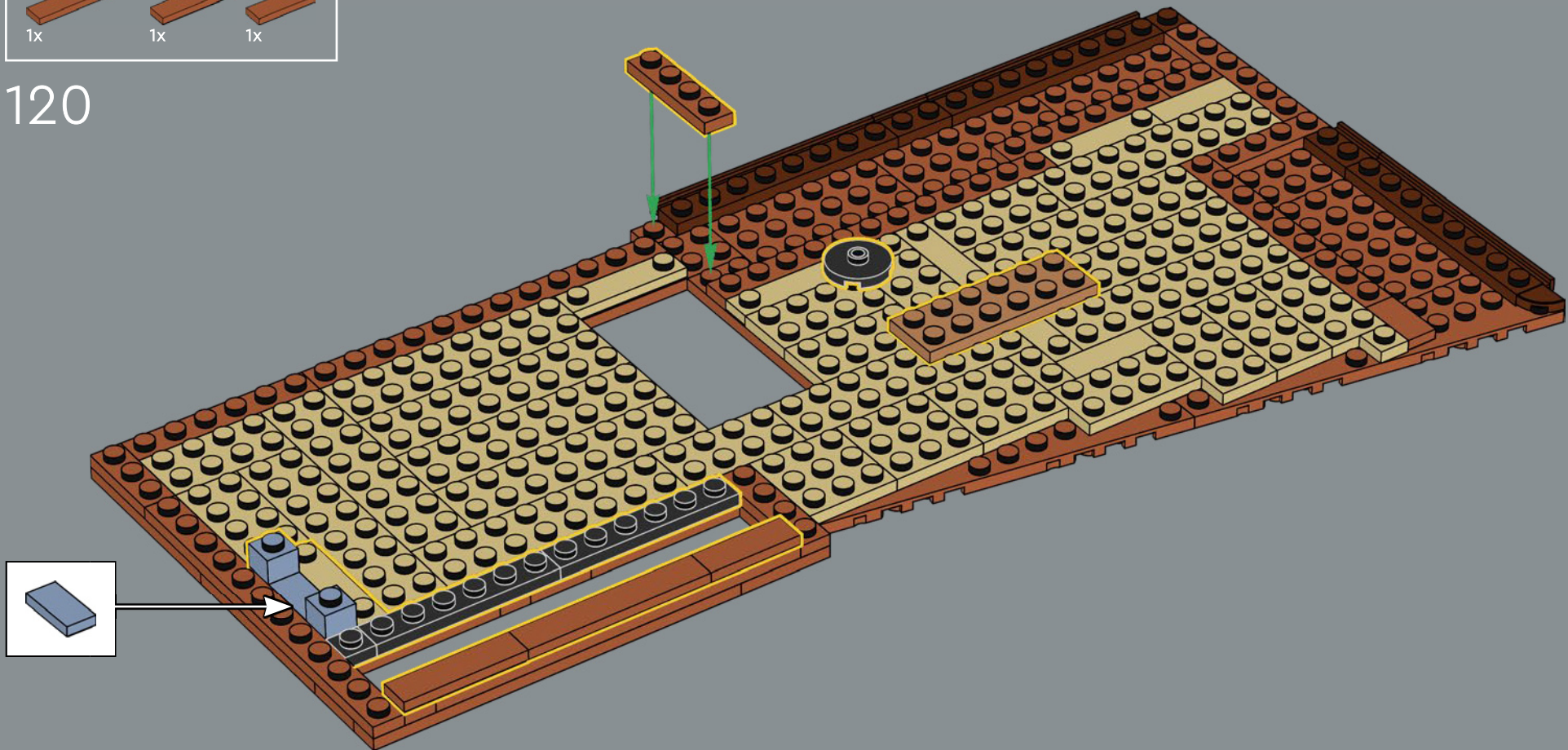

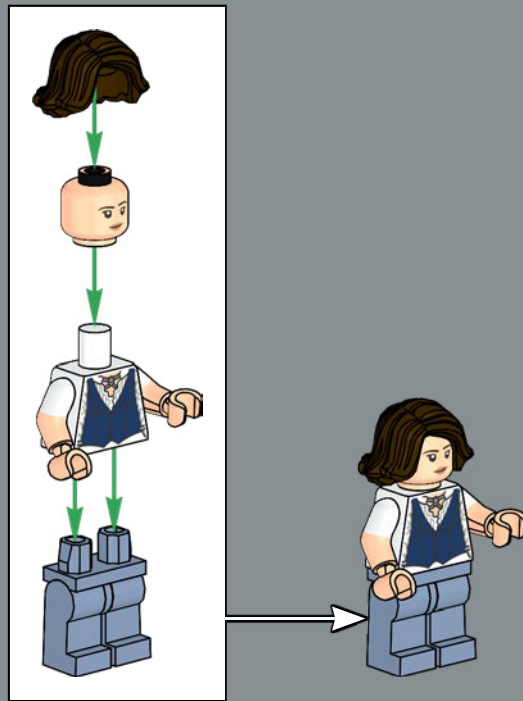

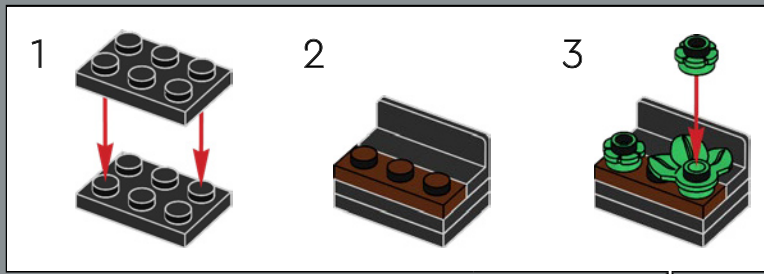
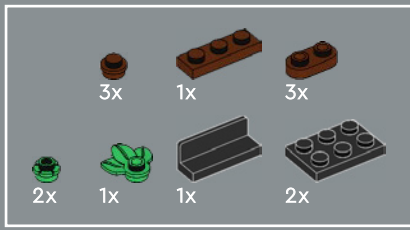

121

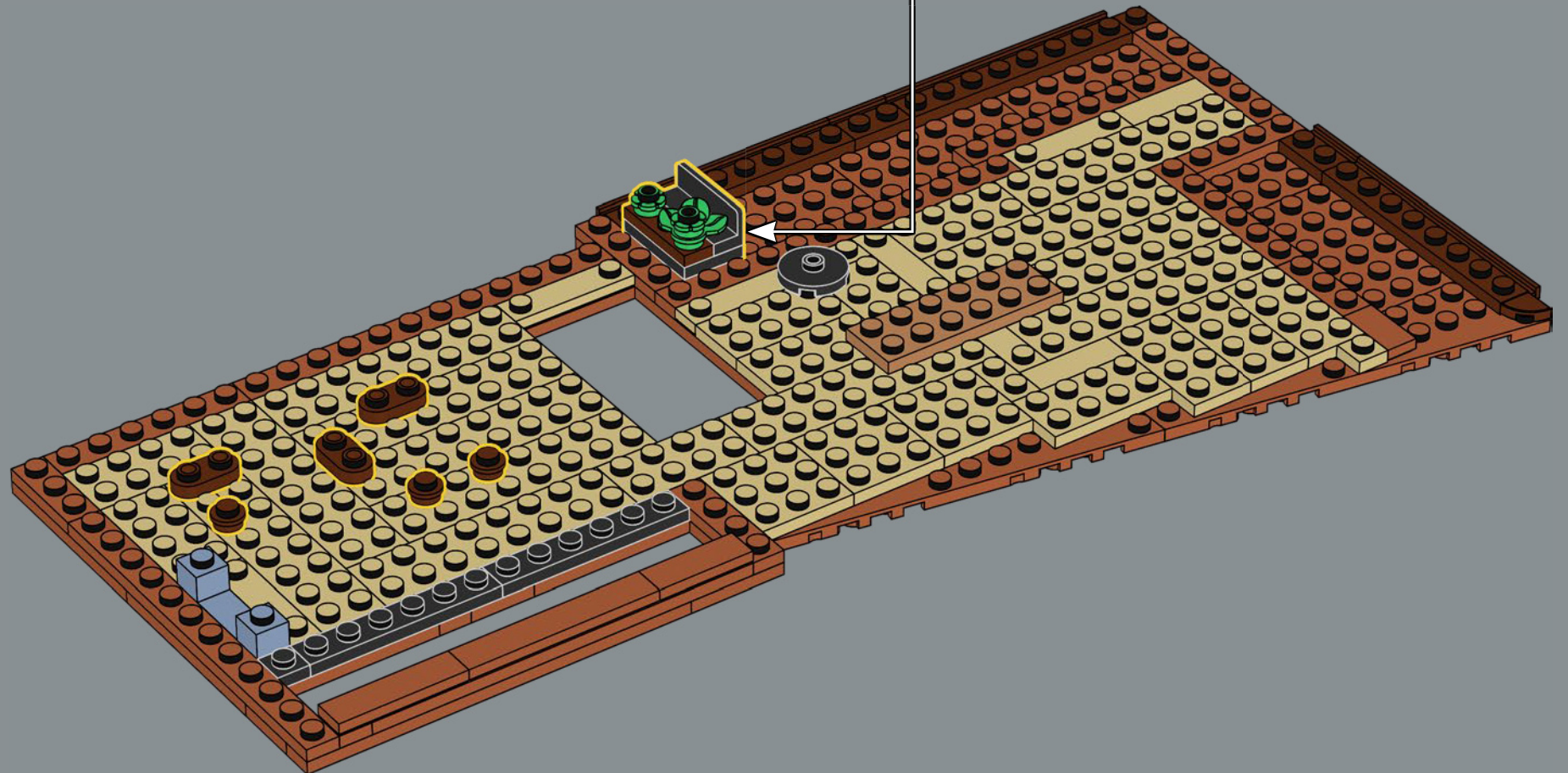

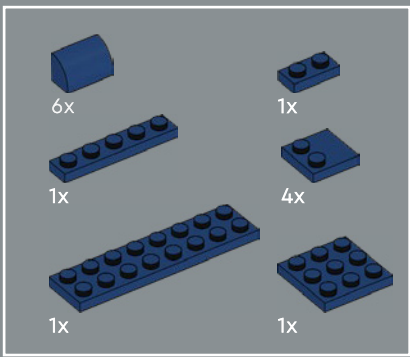

122

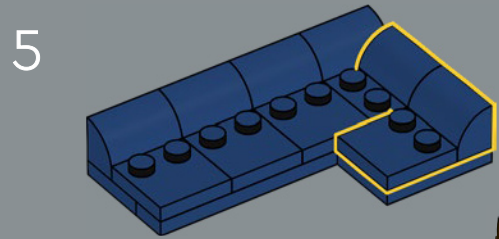
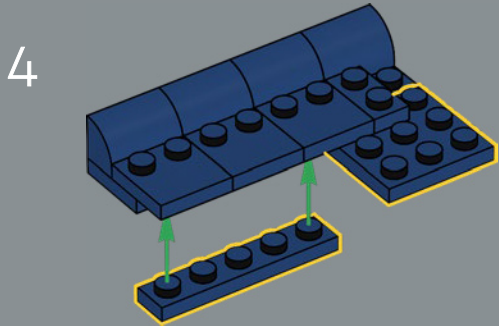
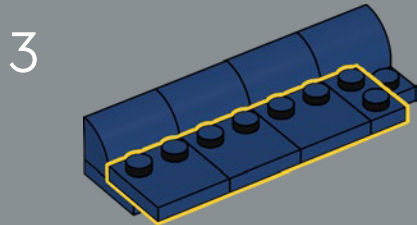
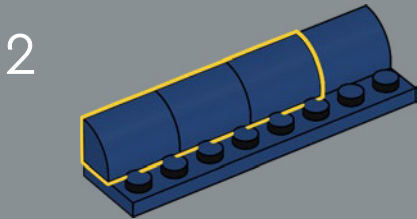
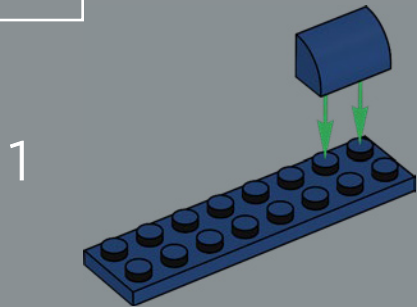

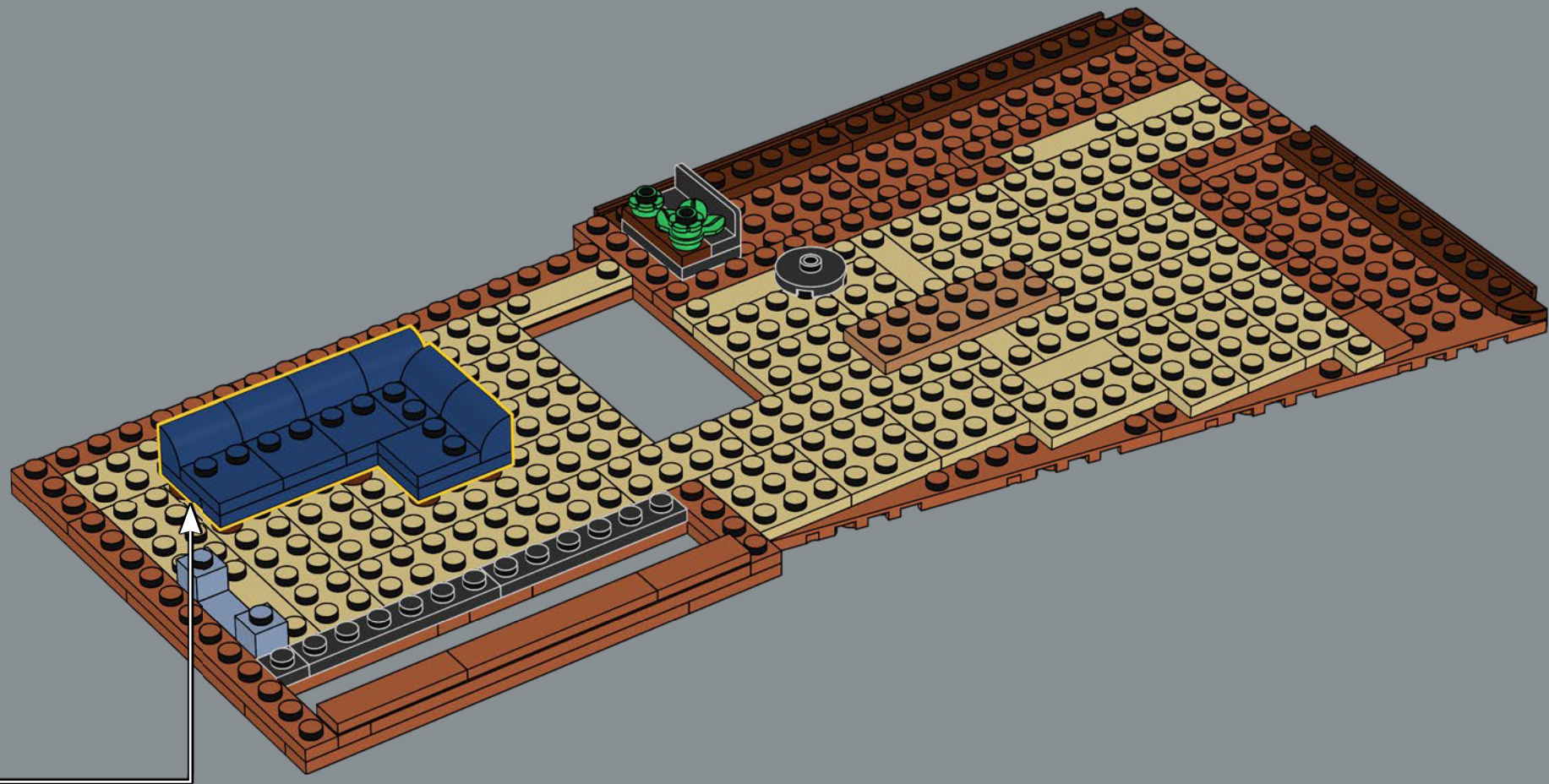

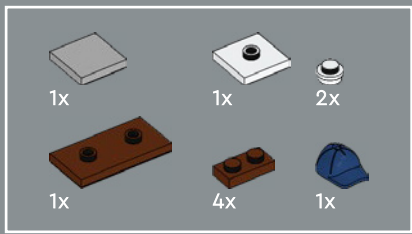

123

1



2

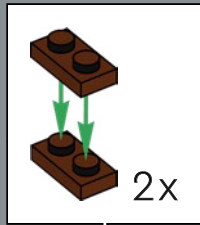
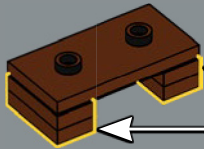

2x

3

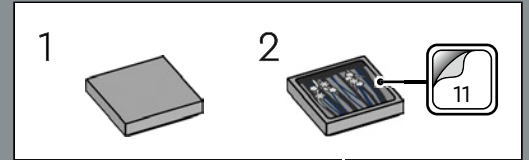
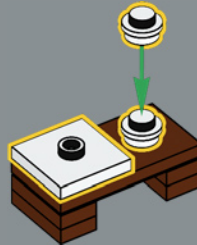

4

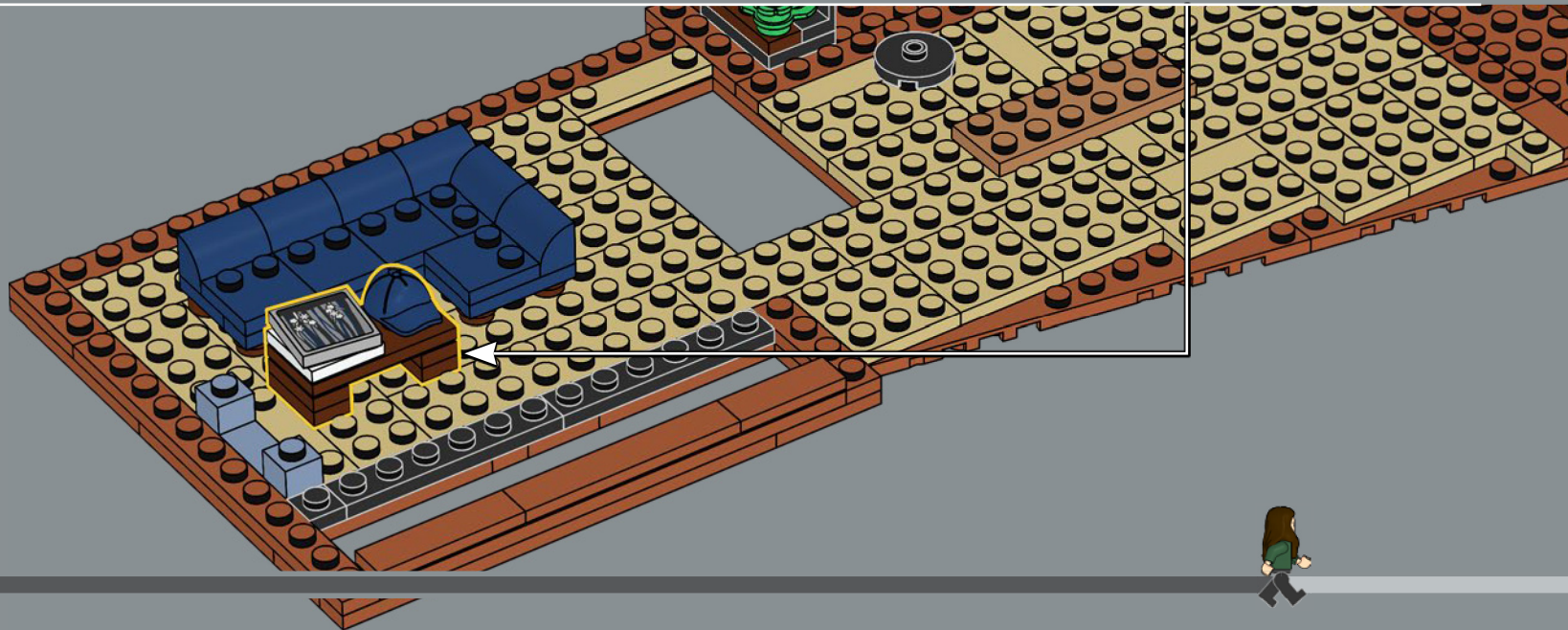

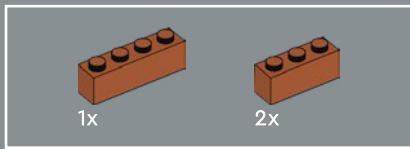

124

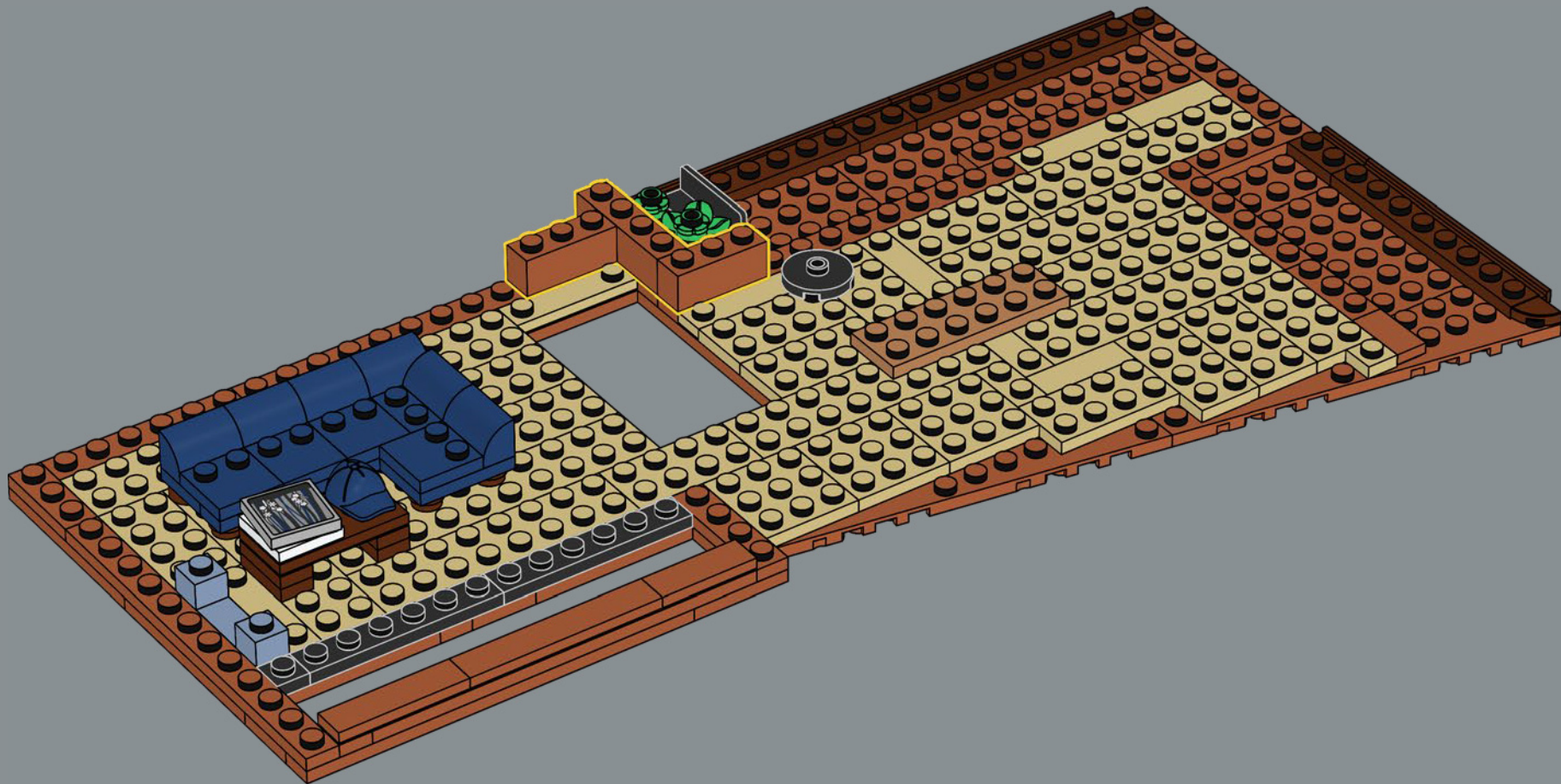

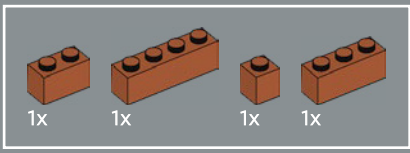

125

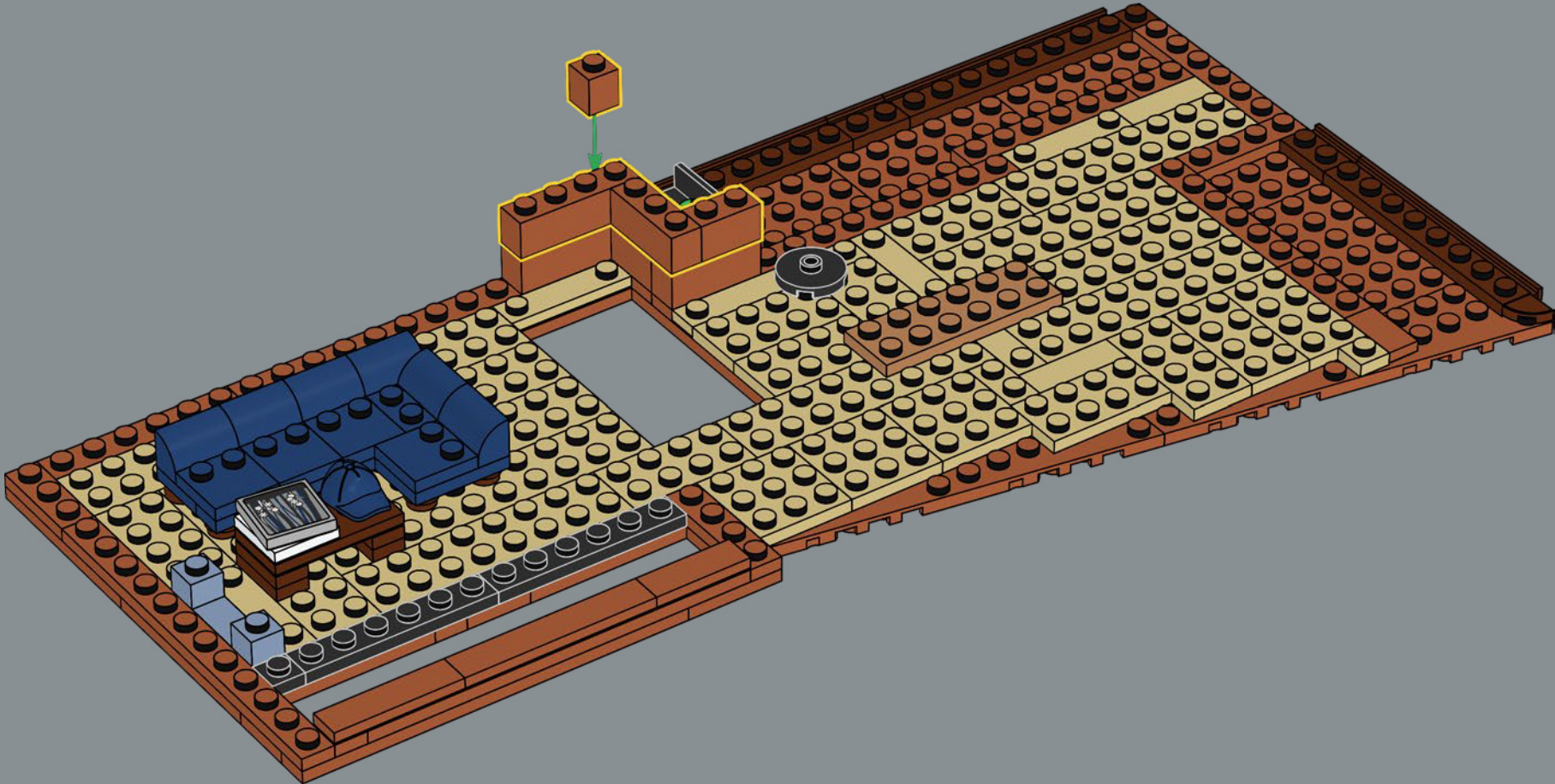

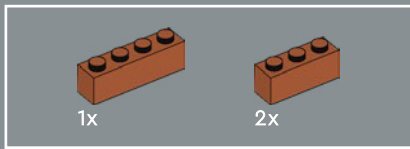

126

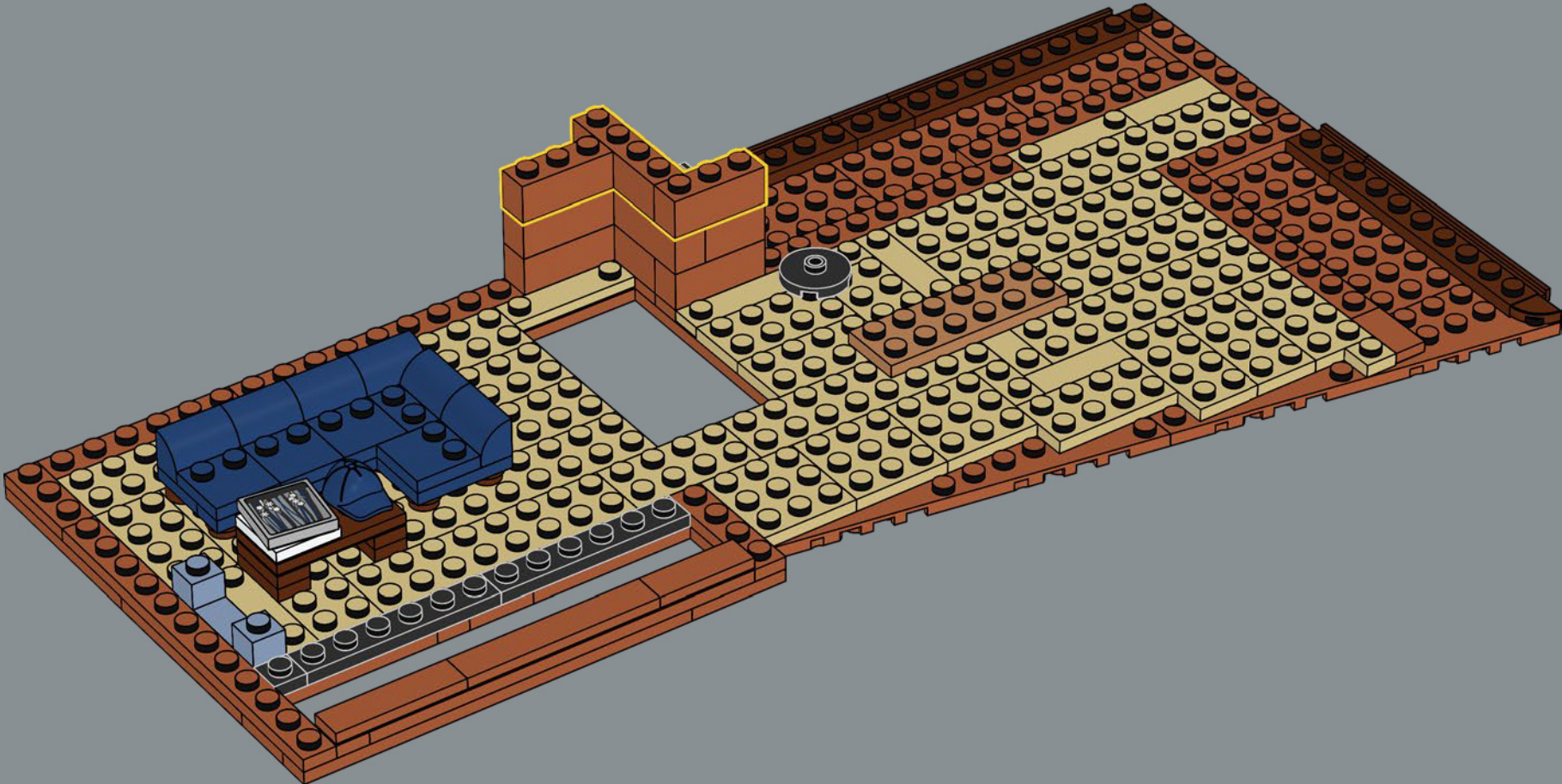

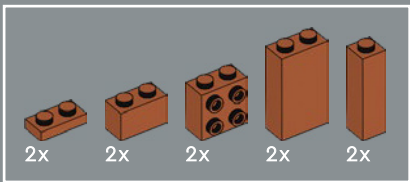

127

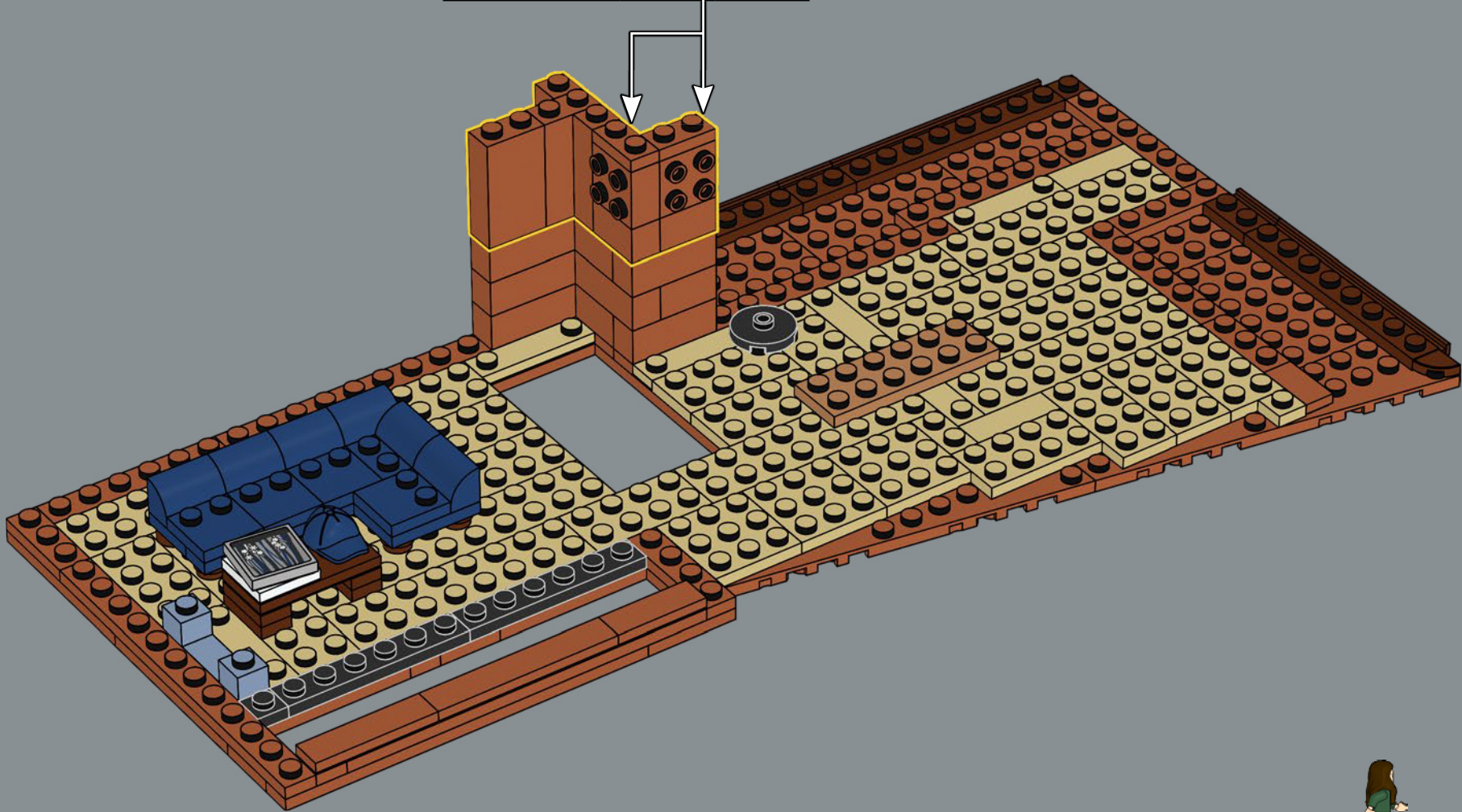
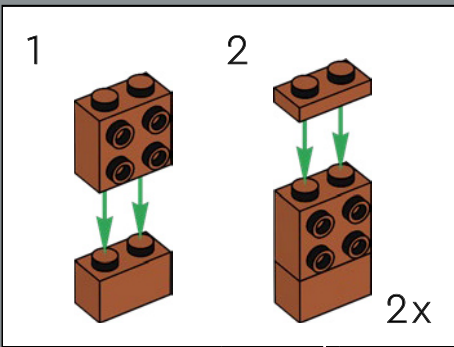

128

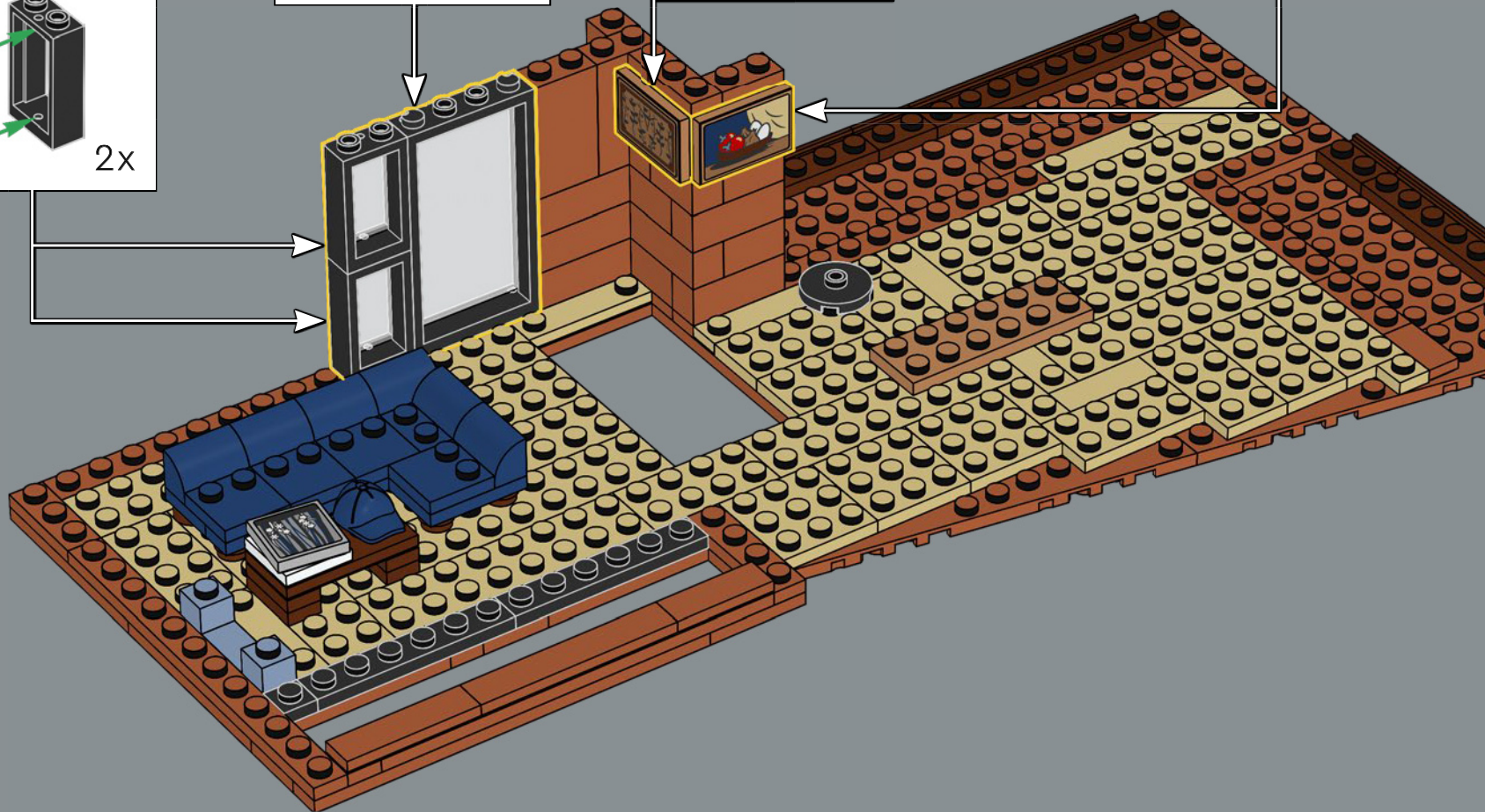
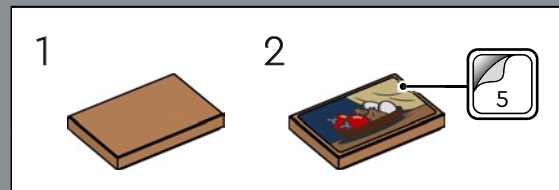
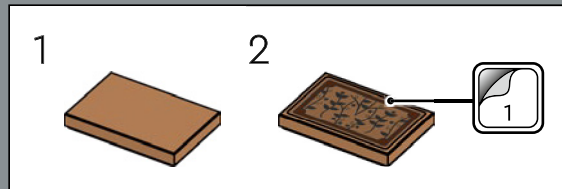
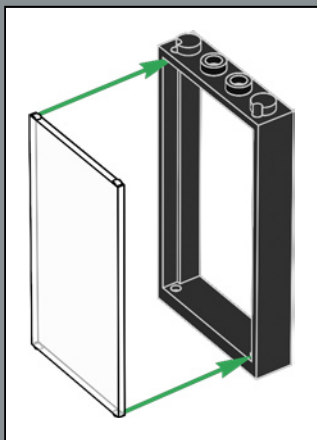
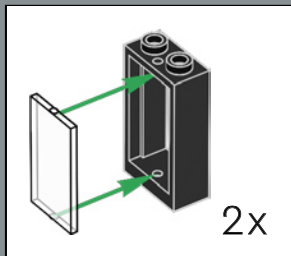
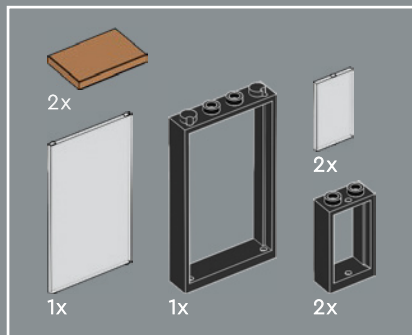

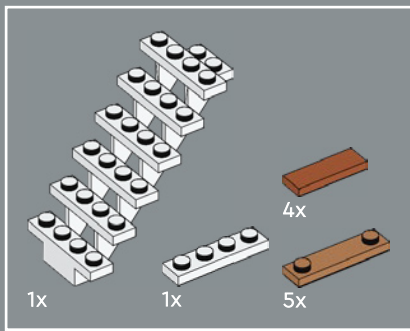

129

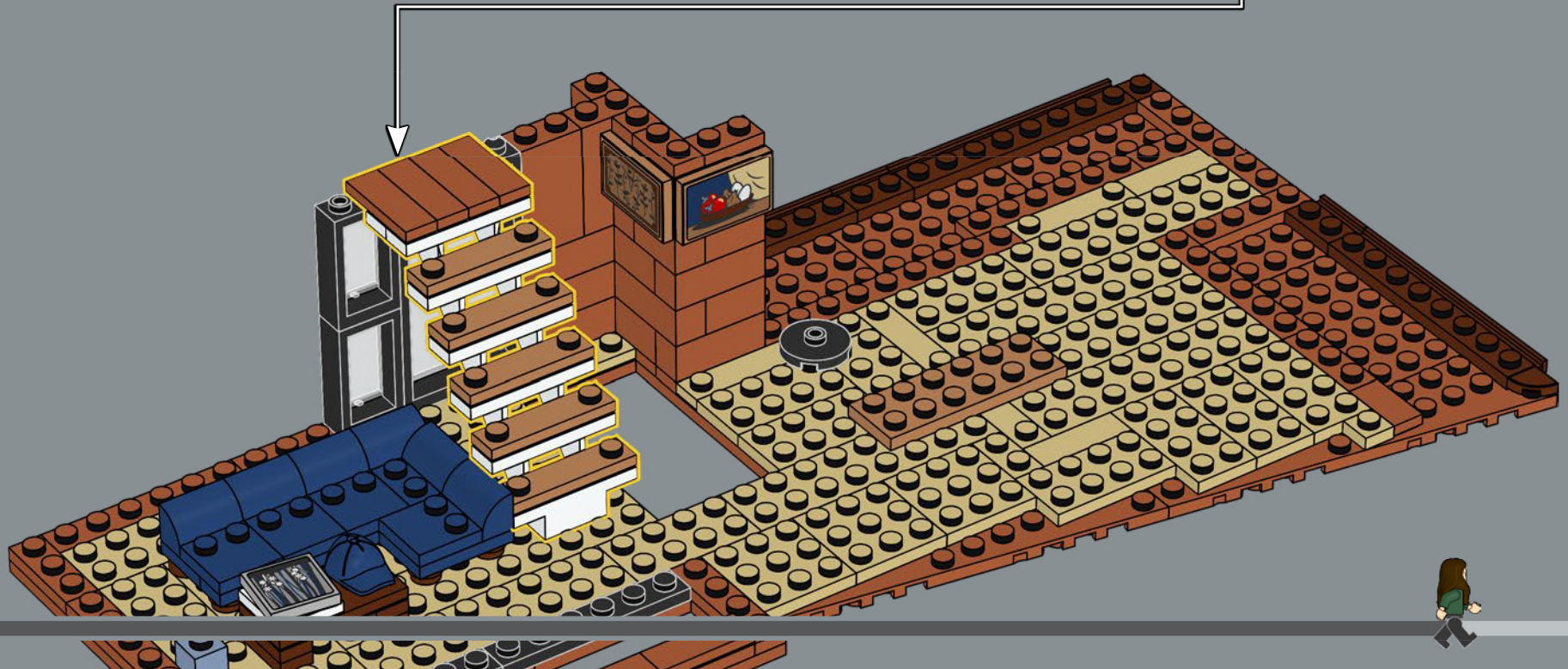
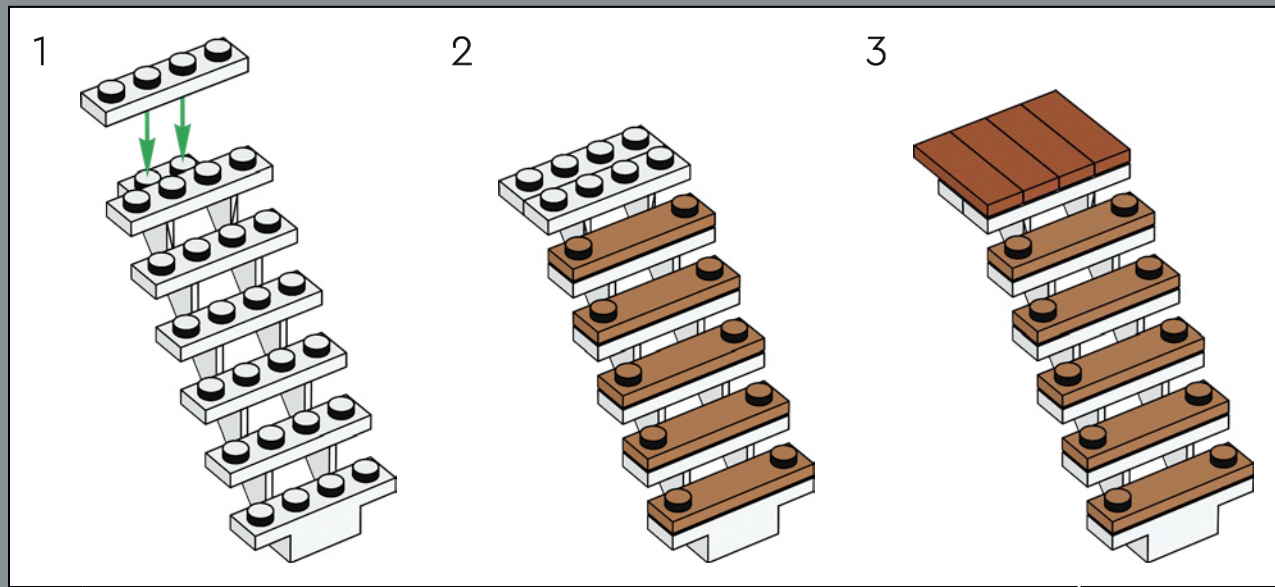

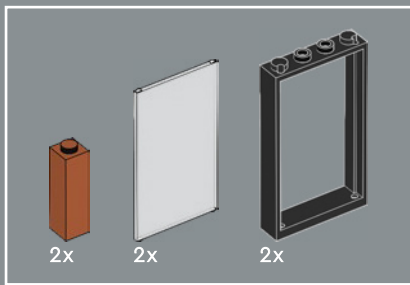

130

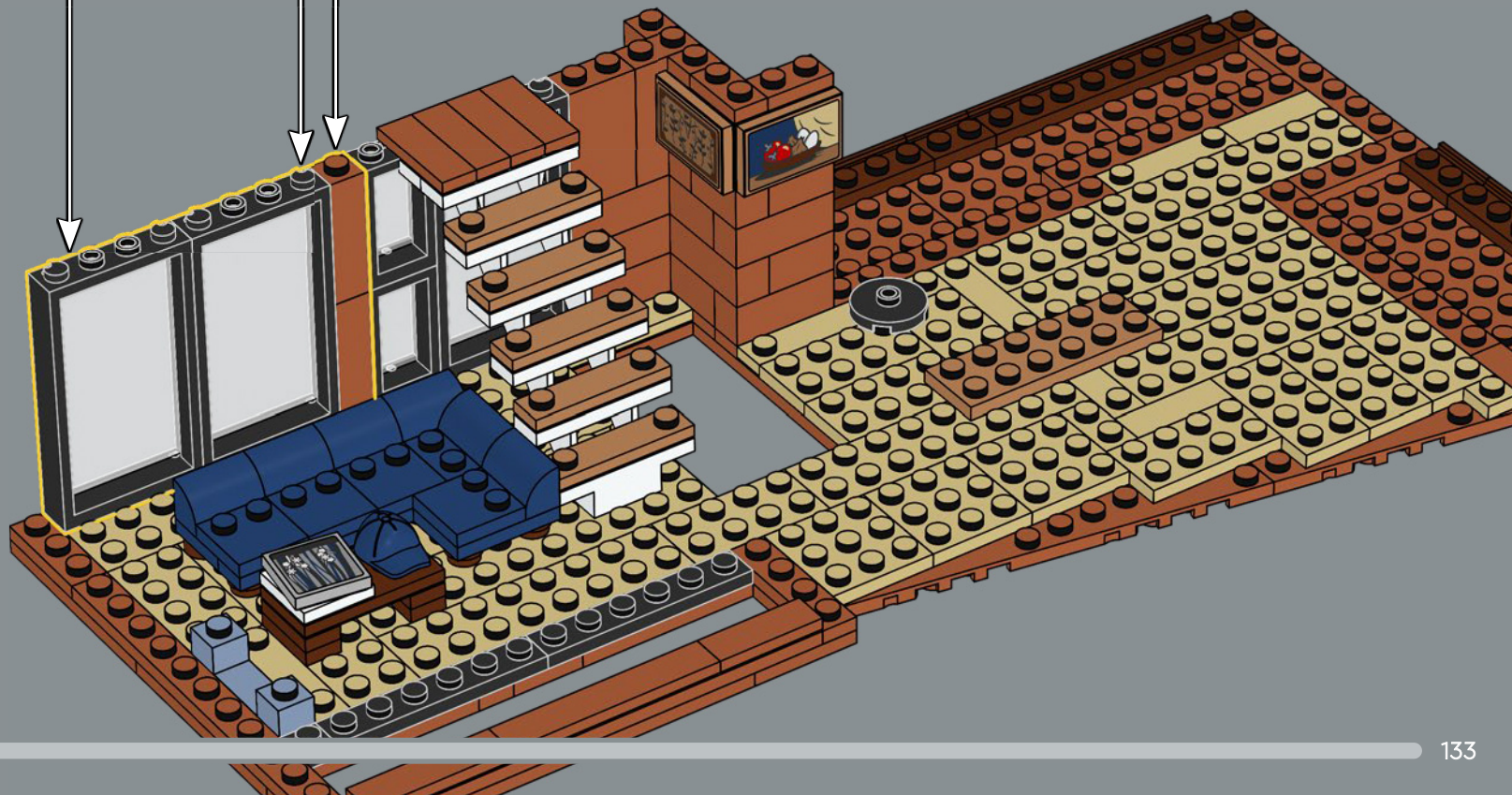
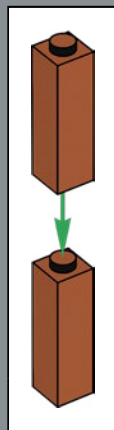
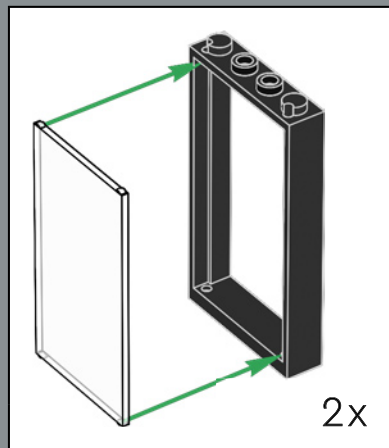

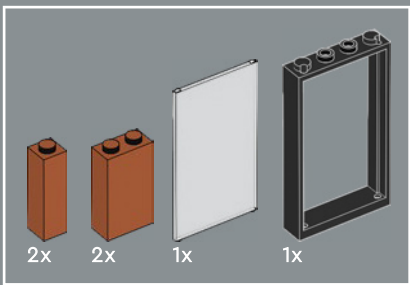

131

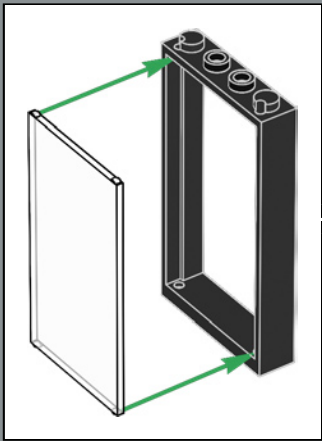
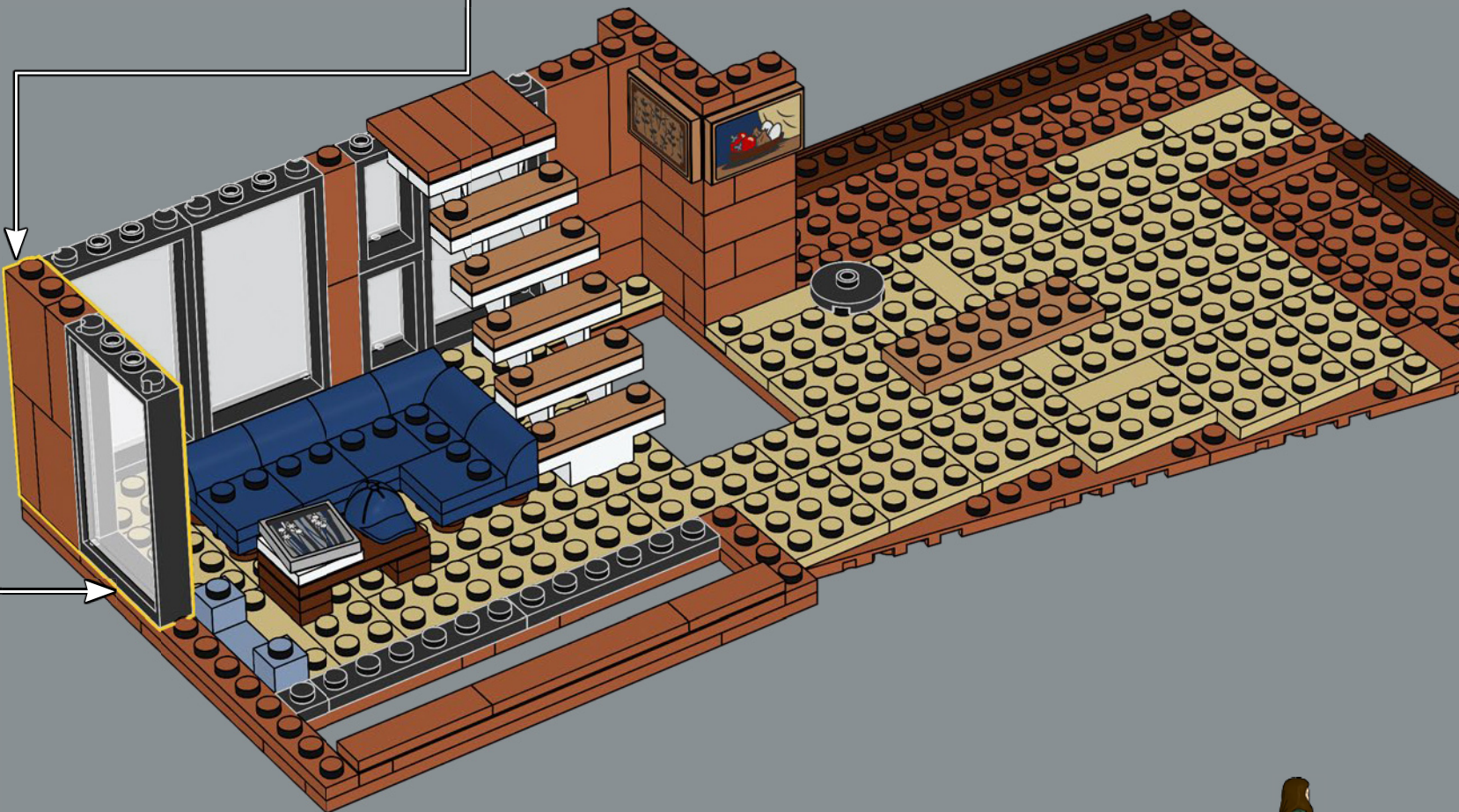
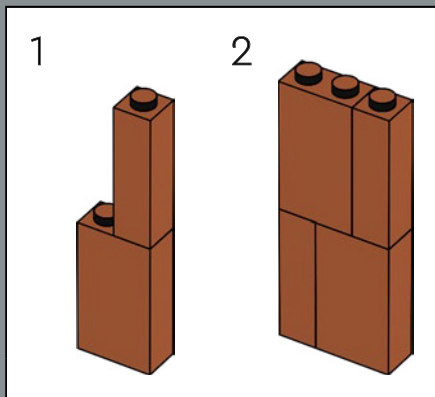

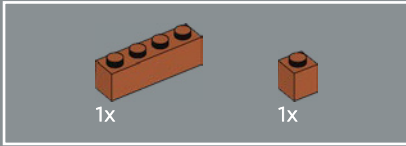
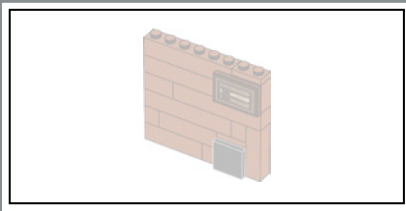

132

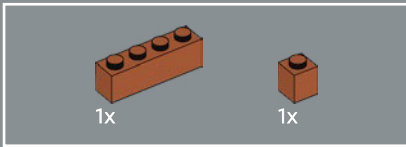
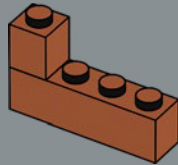

133

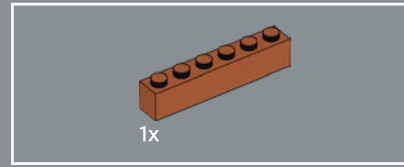
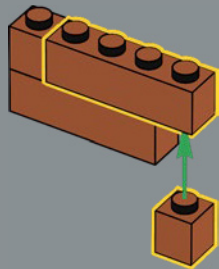

134

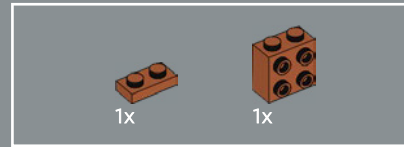
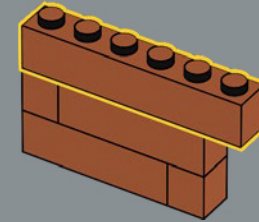

135

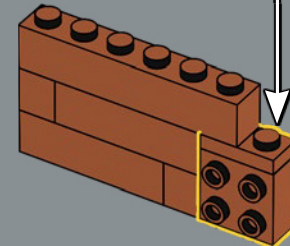
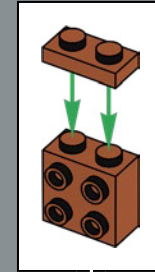

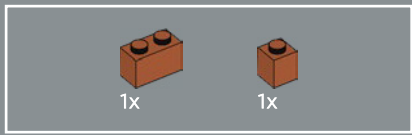

136

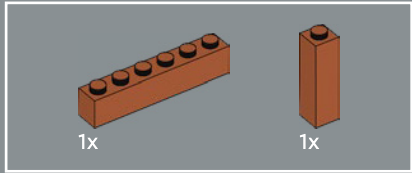
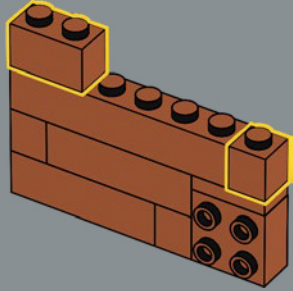

137

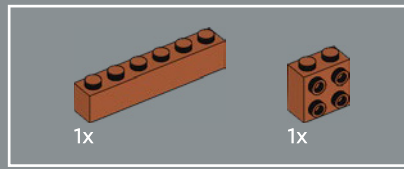
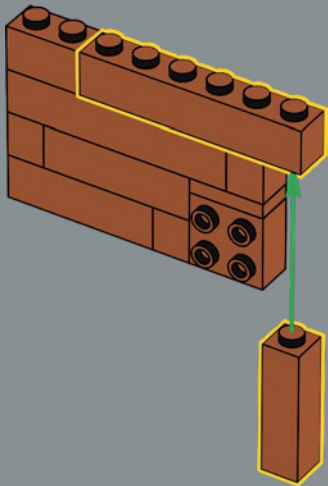

138

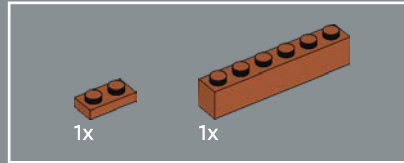
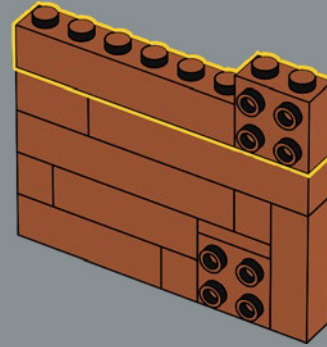

139

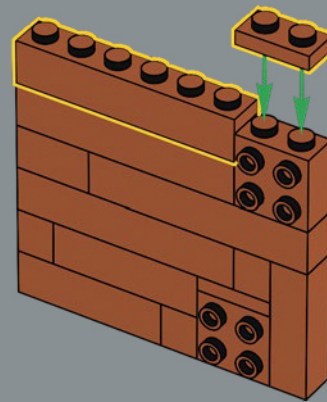

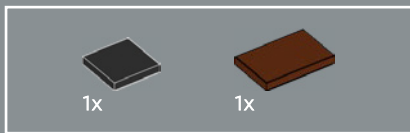

140

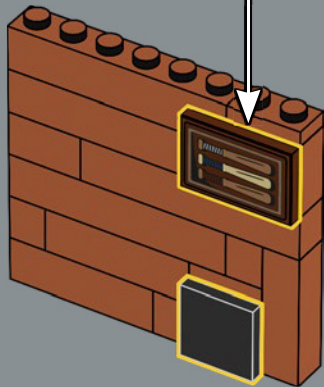

141

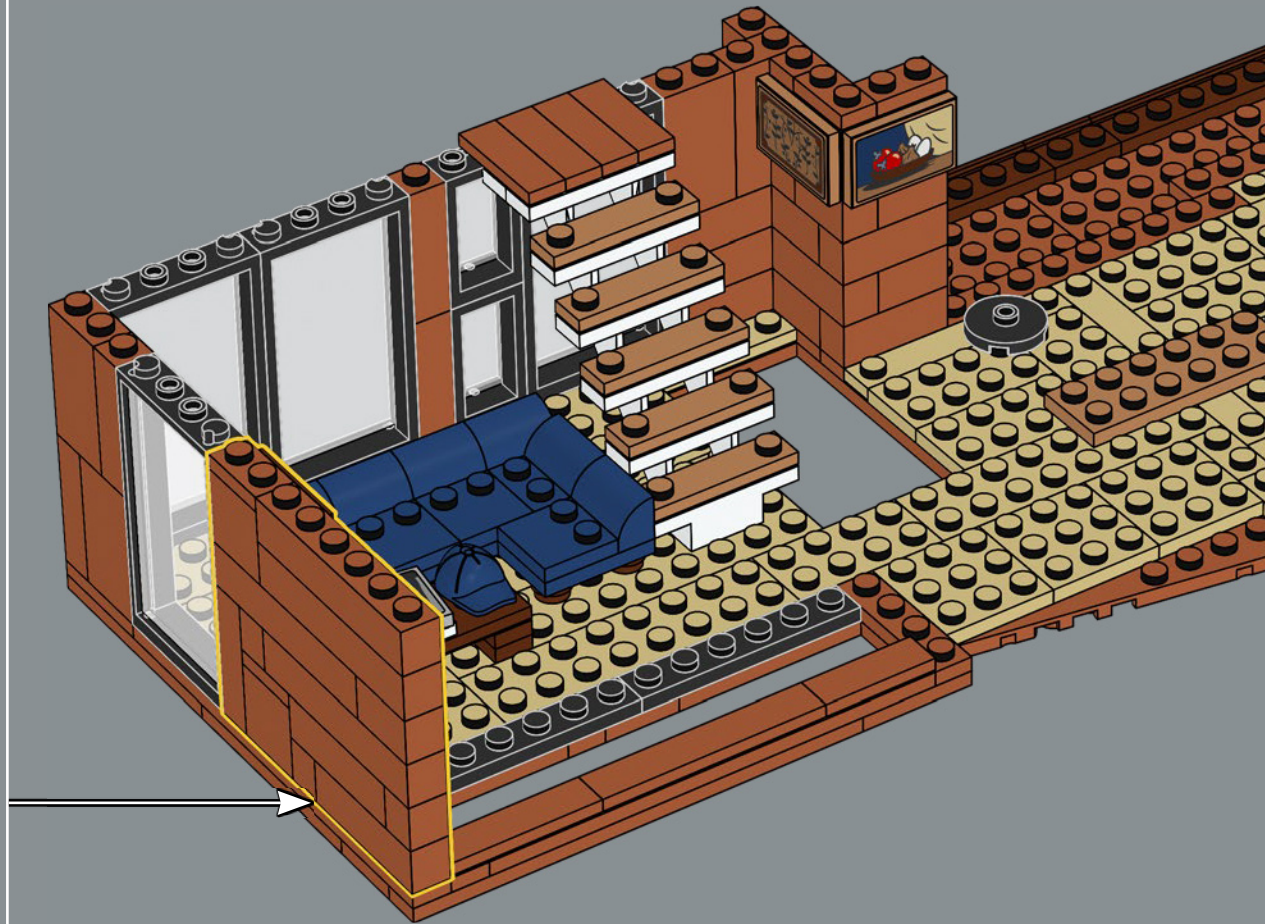

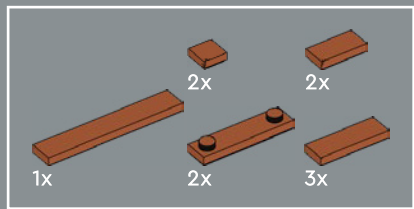

142

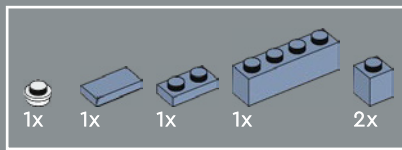
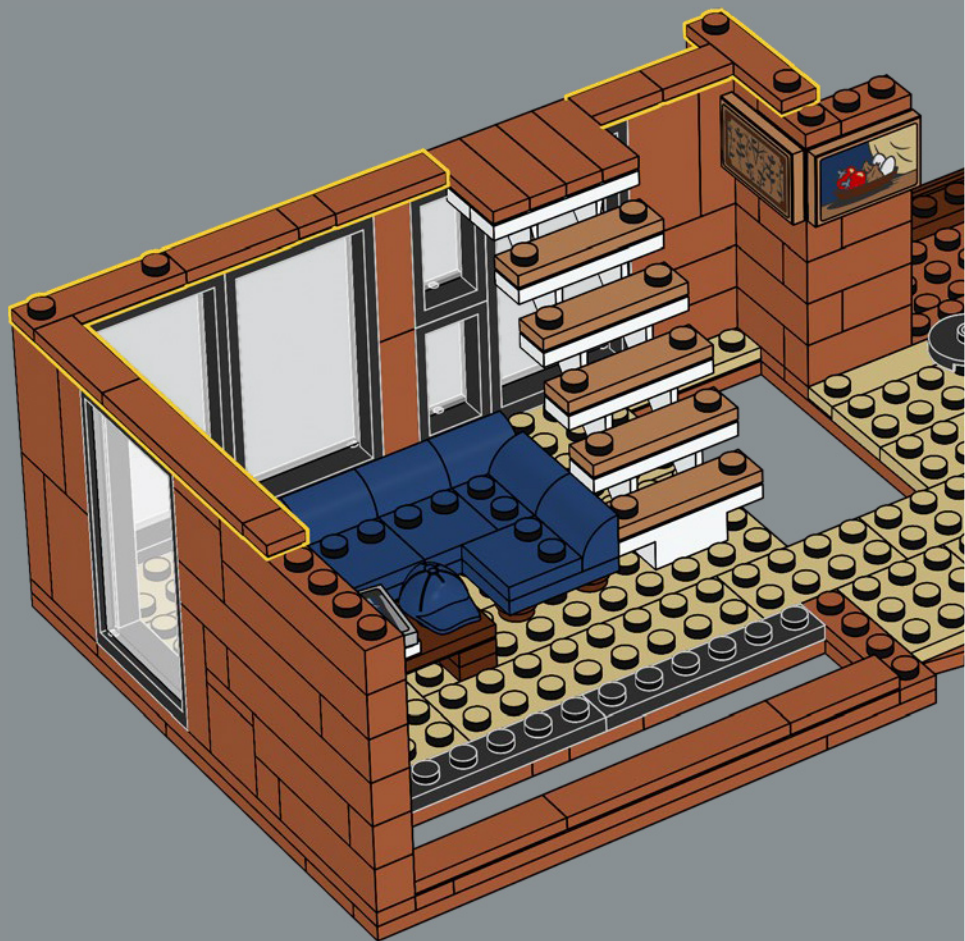

143

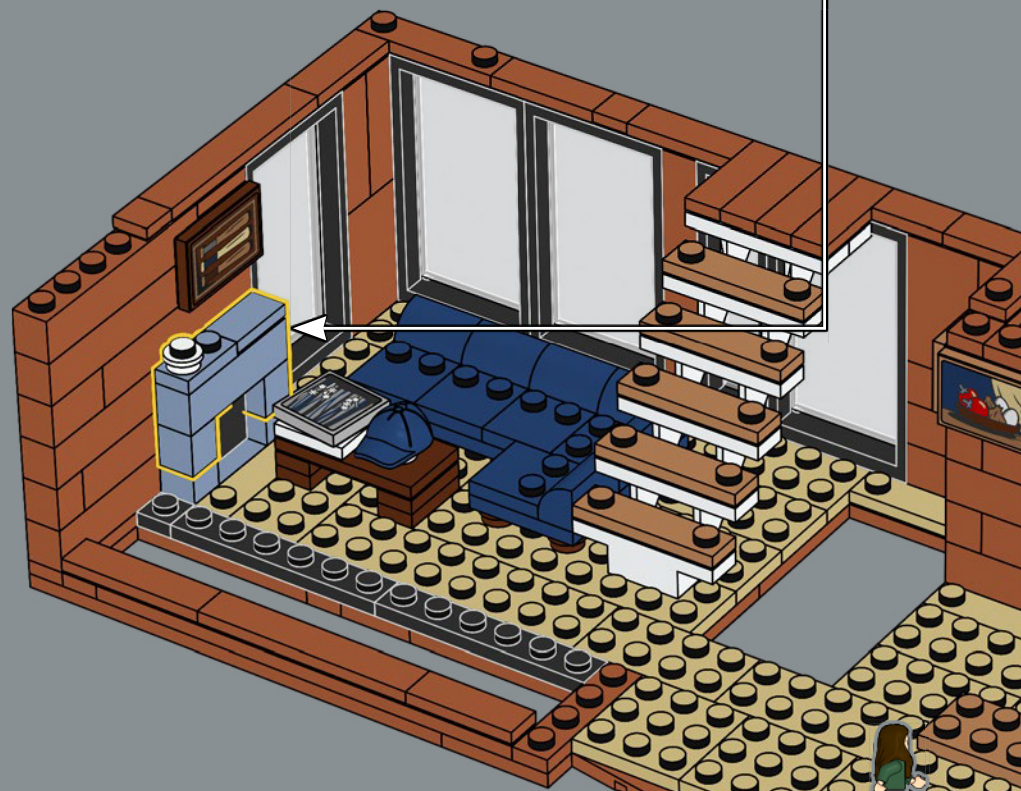
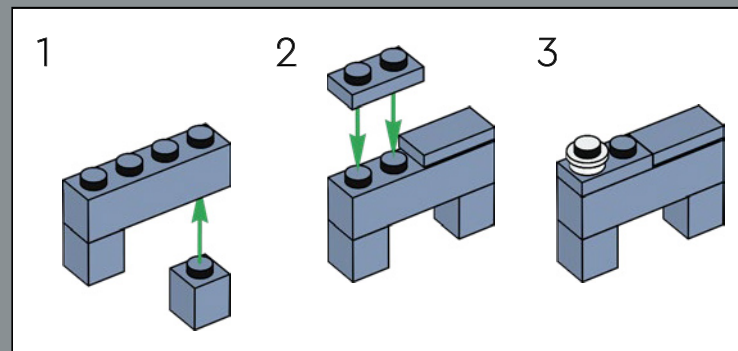

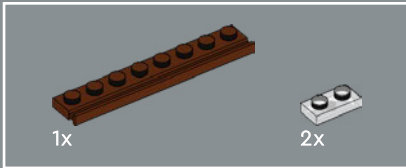
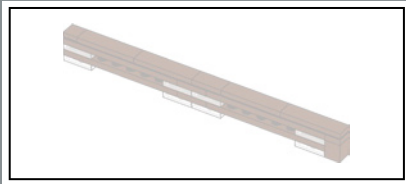

144

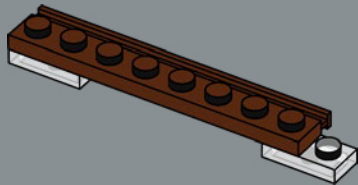

145

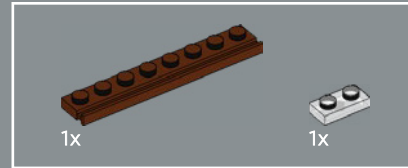
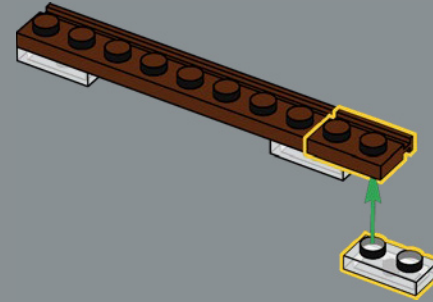

146

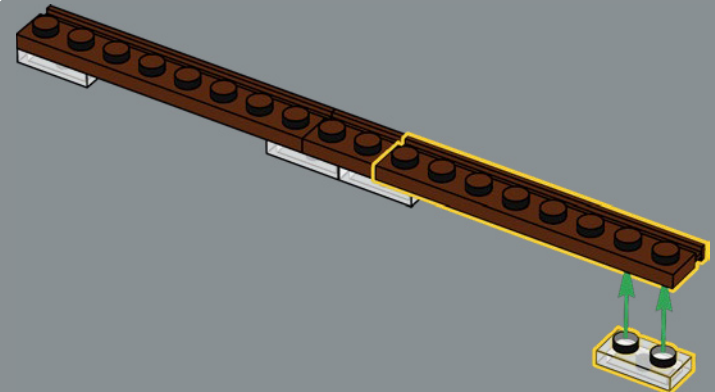



4x

147

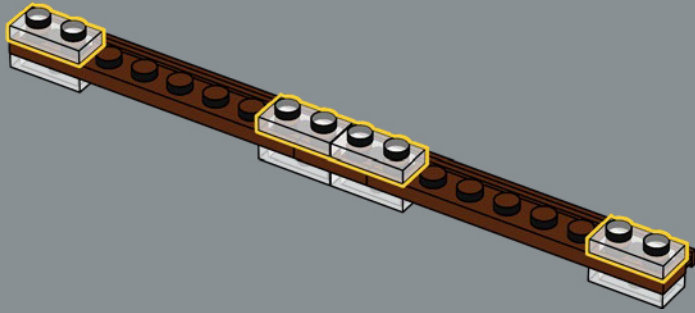

1x



2x

148

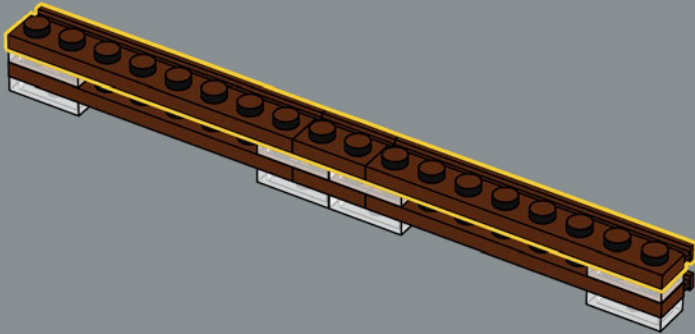

1x



4x



1x

149

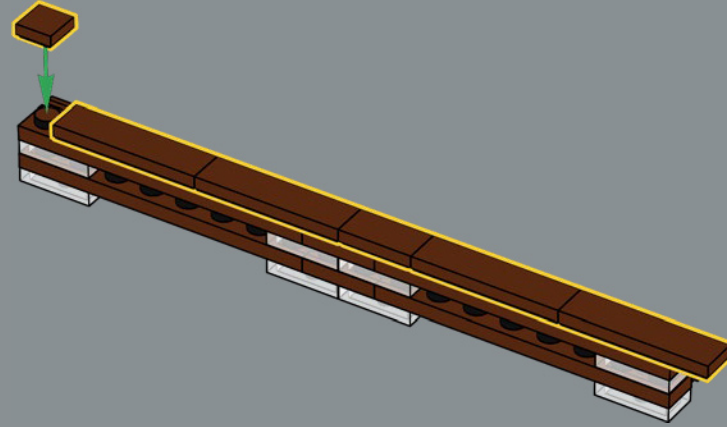

1x



1x

150

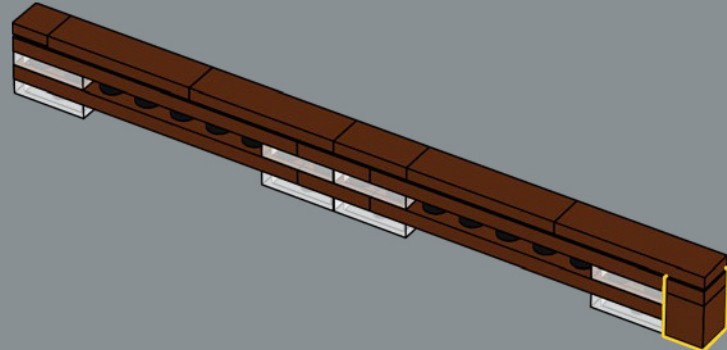

151

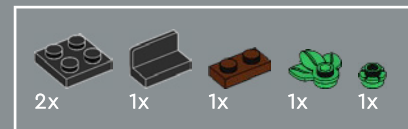
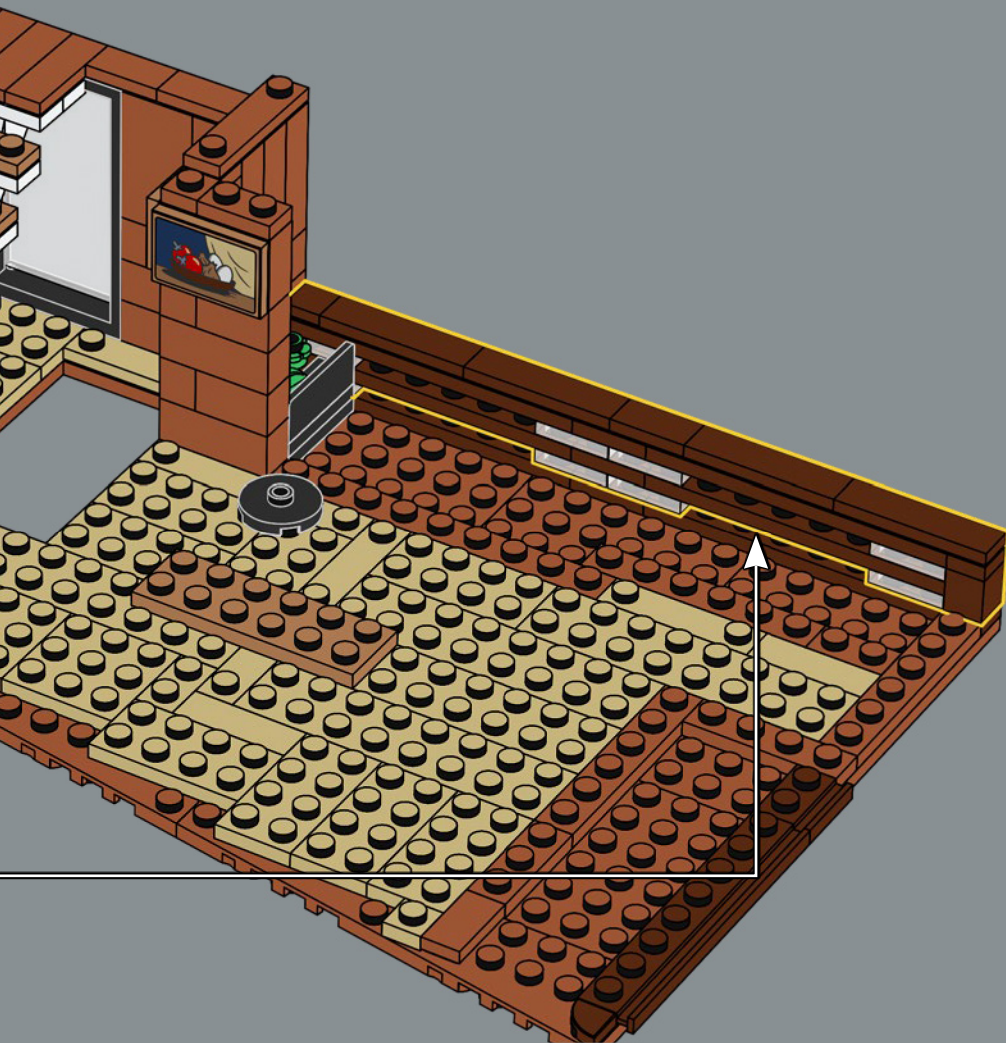

152

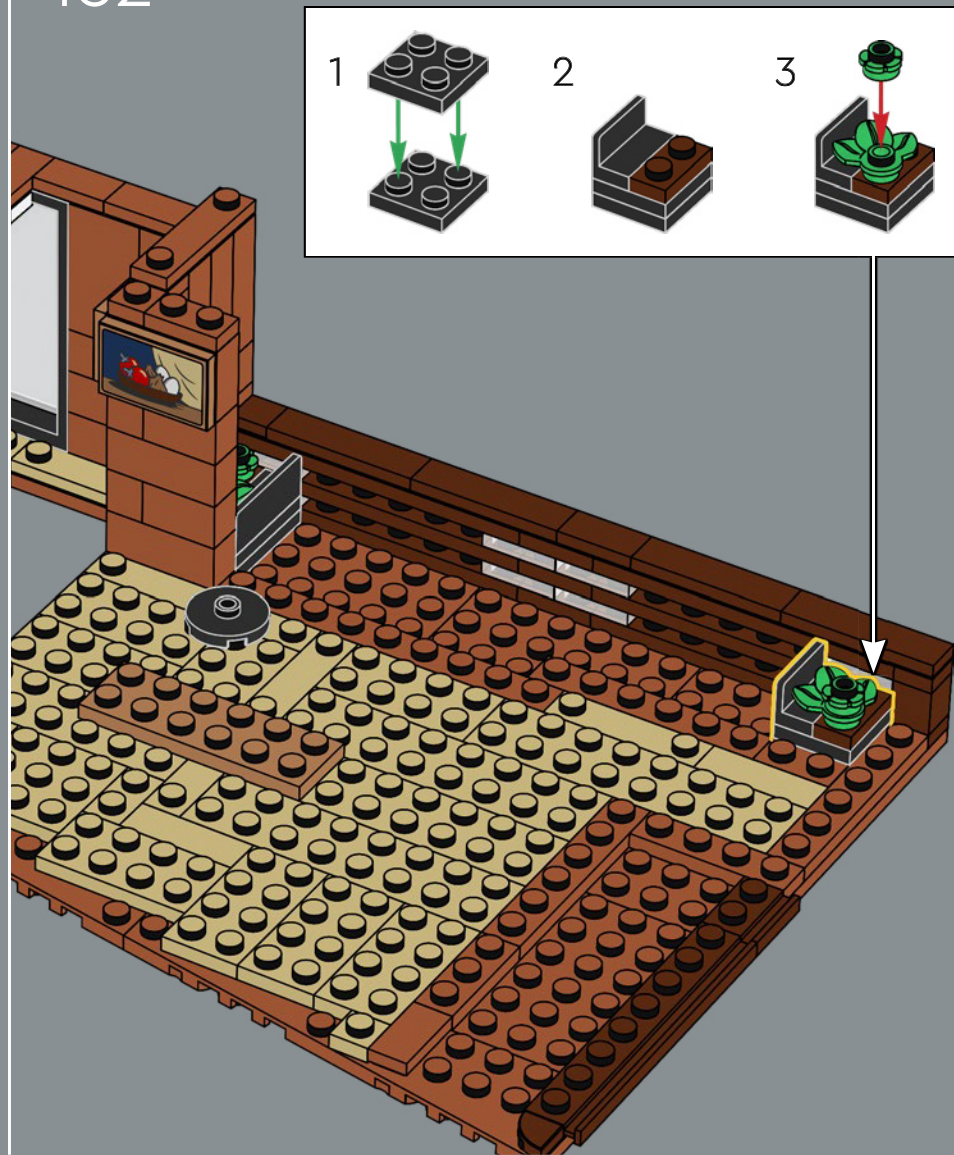

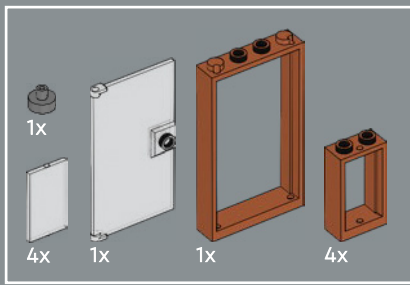

153

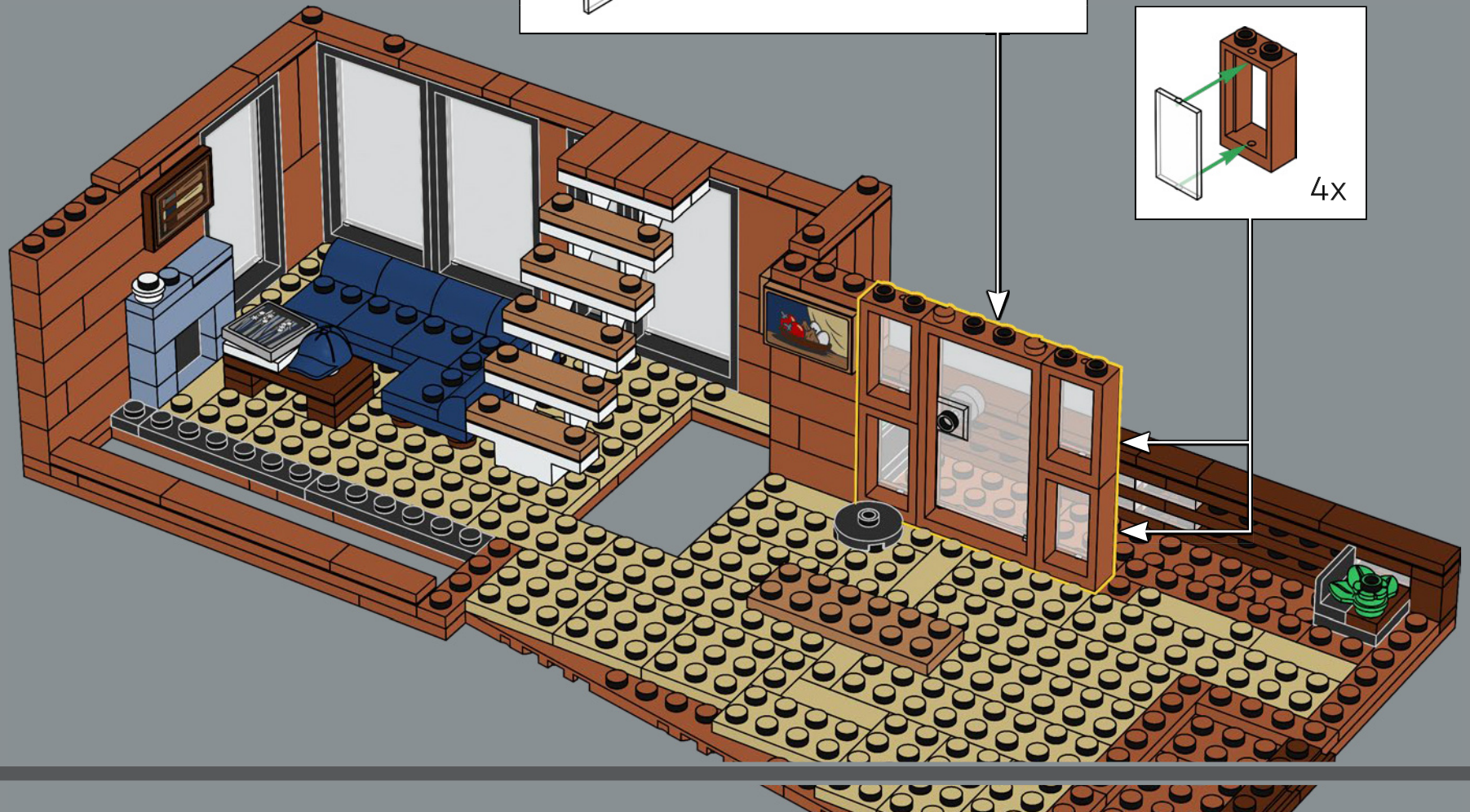
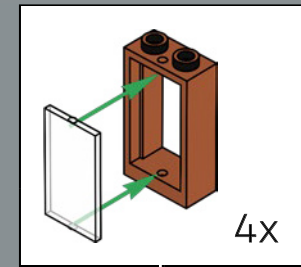
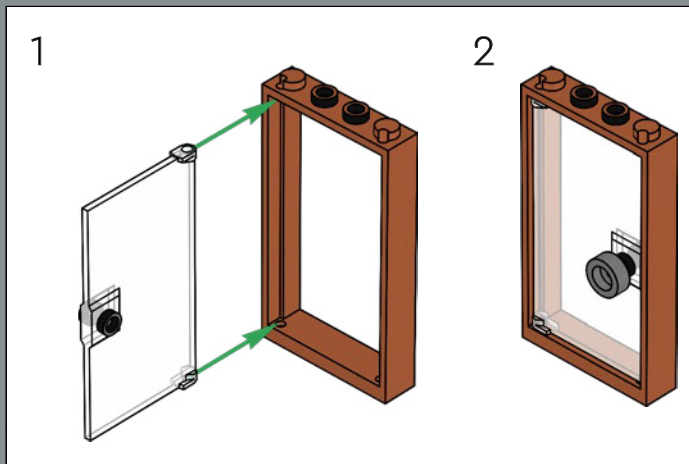

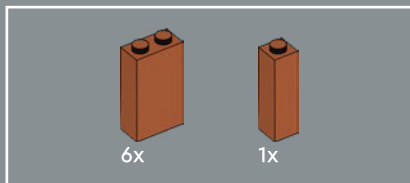

154

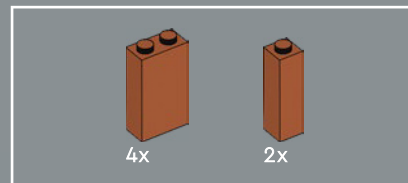
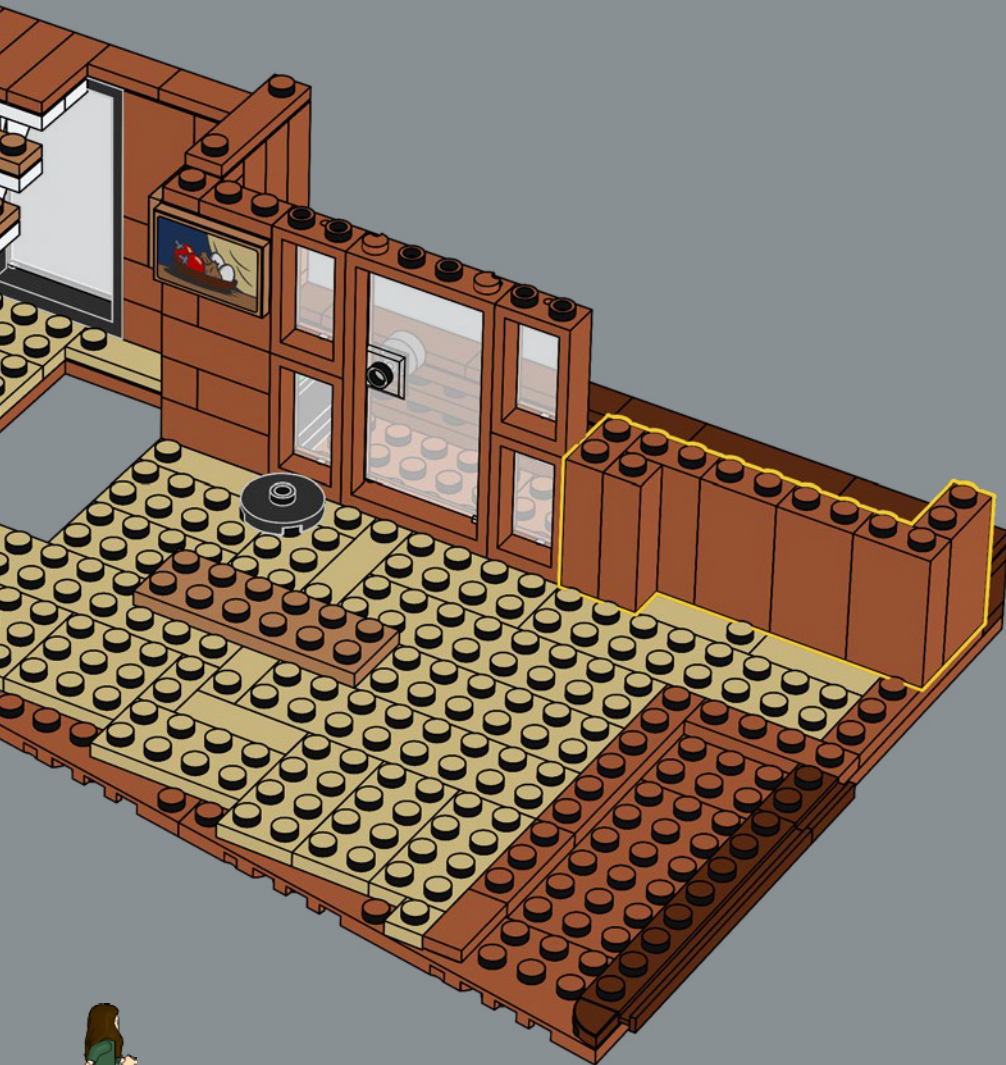

155

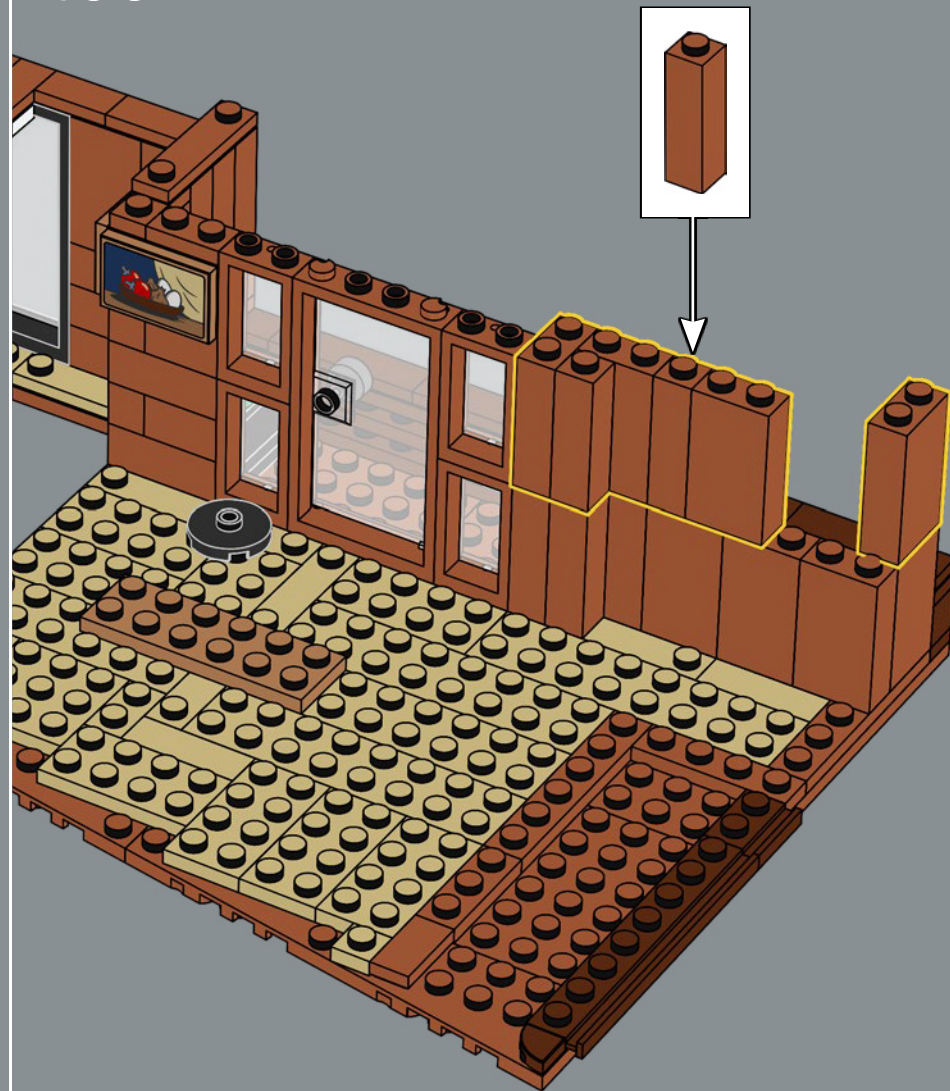

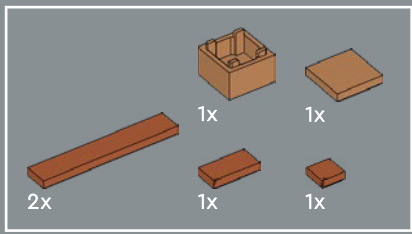

156

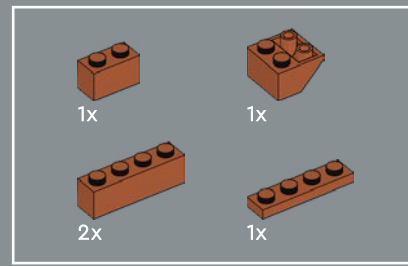
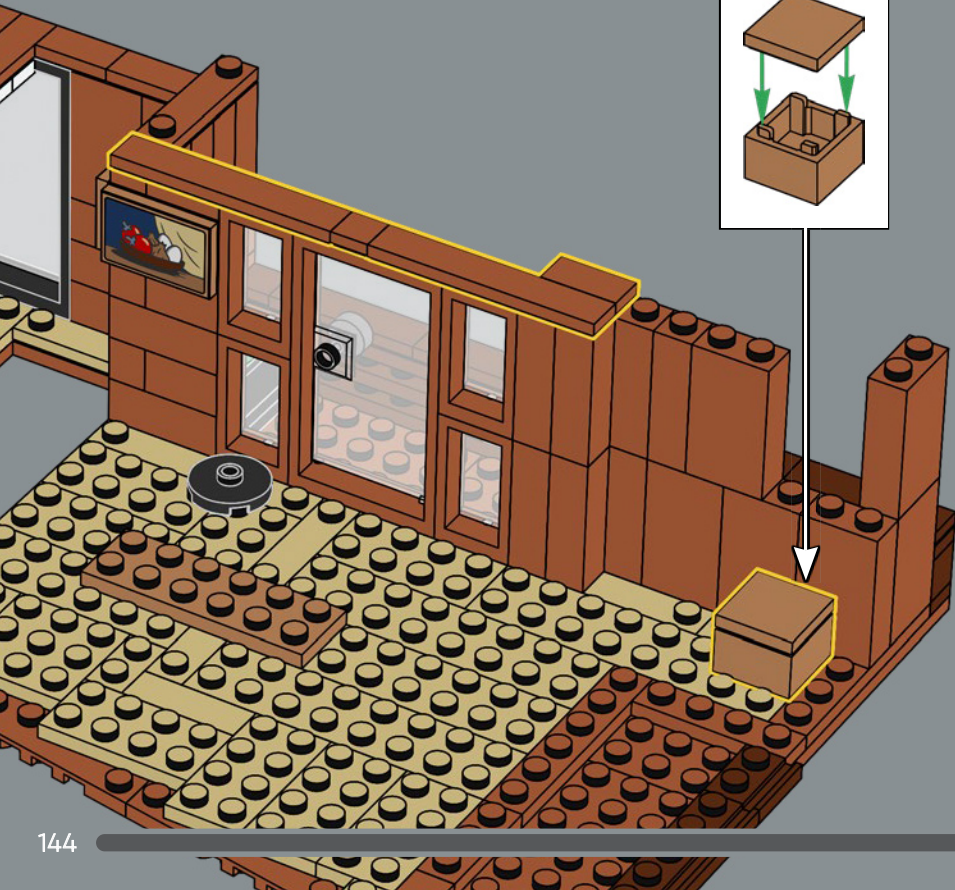

157

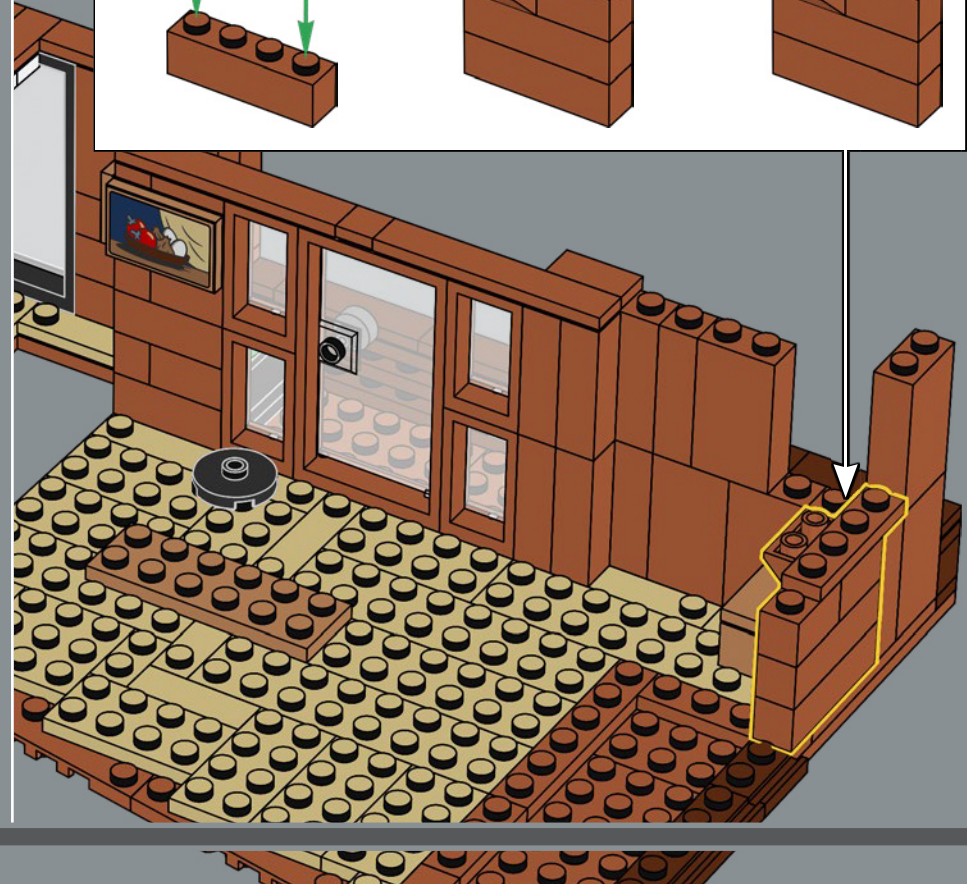
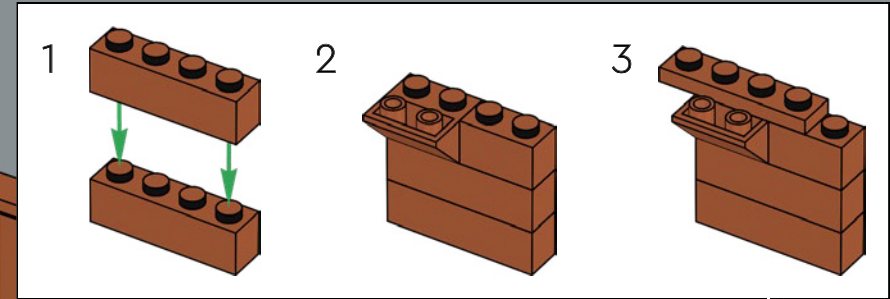

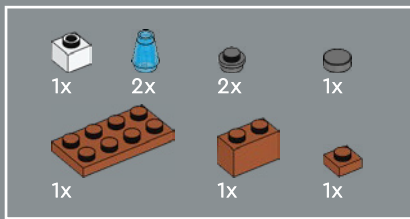

158

1

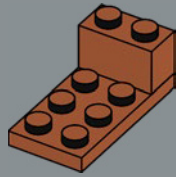

2

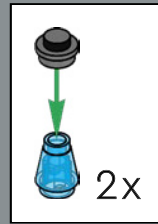
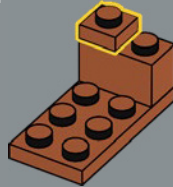

3

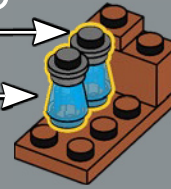

4

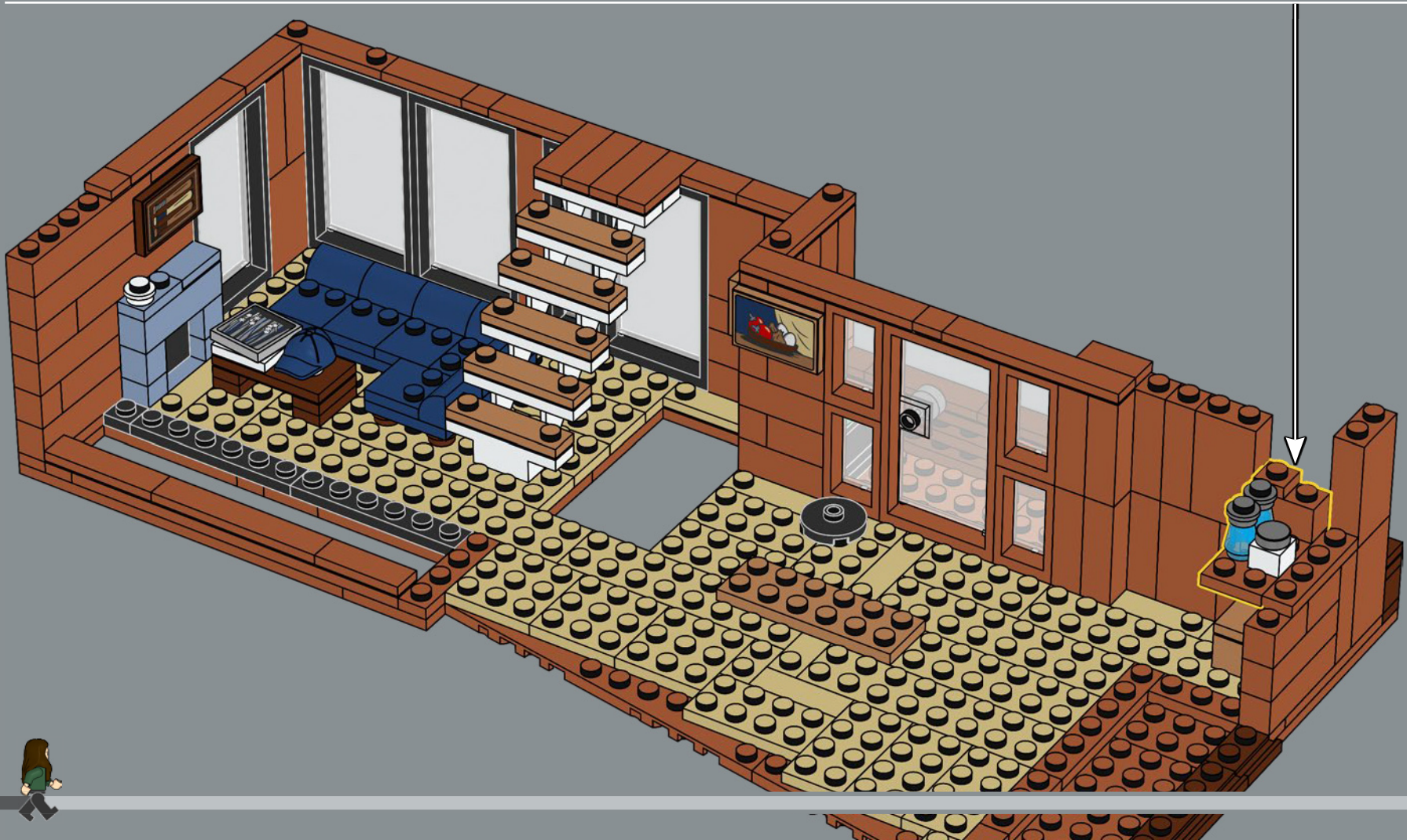
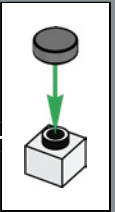
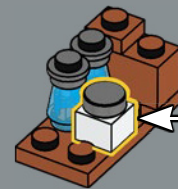

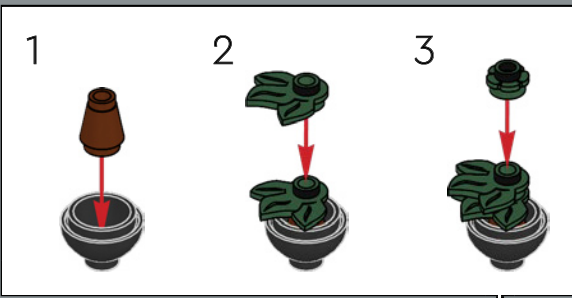
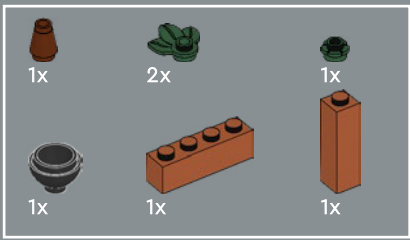

159

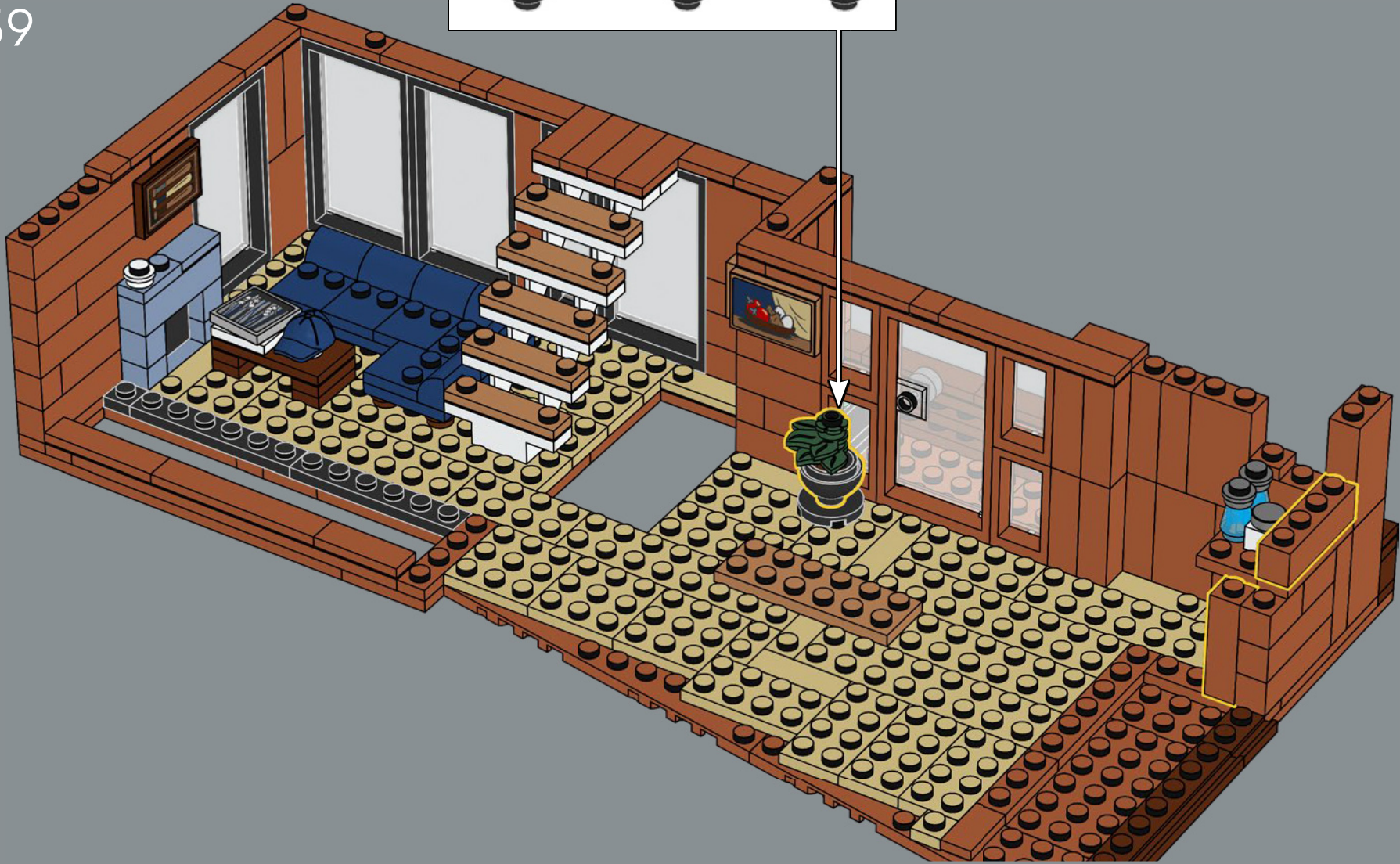

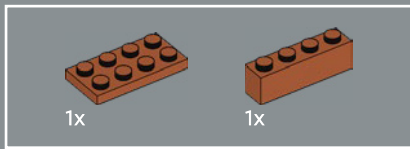

160

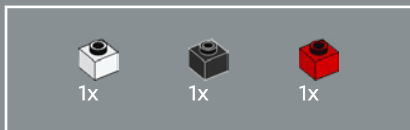
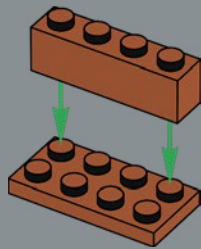

161

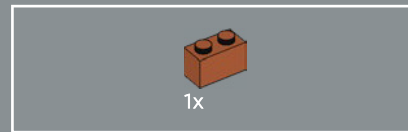
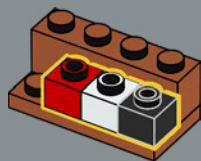

162

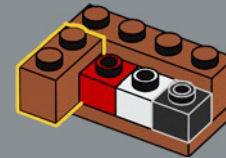

163

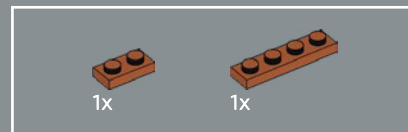

164

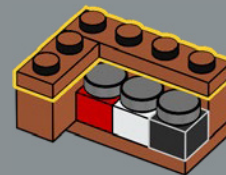

165

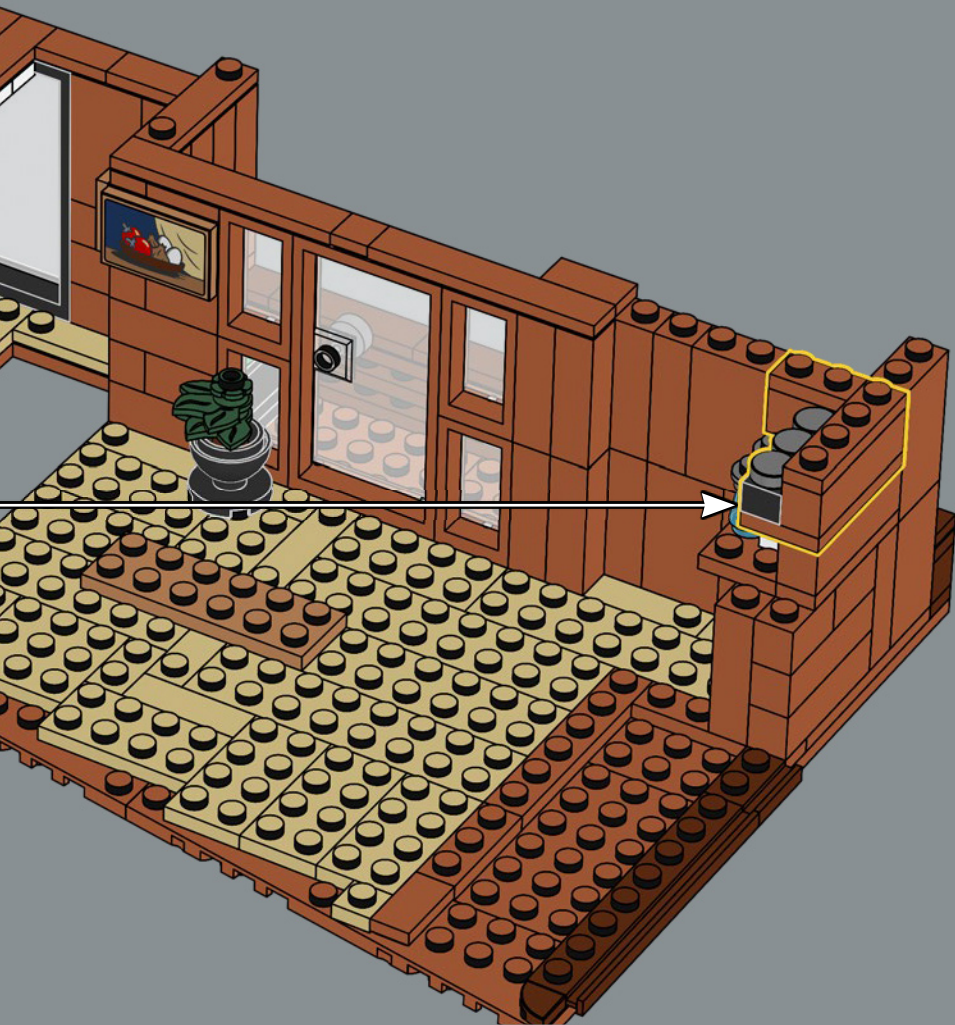

166

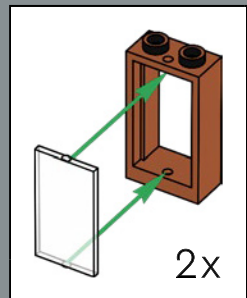
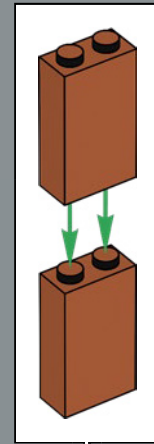
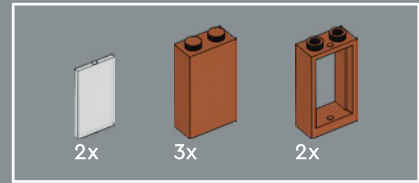
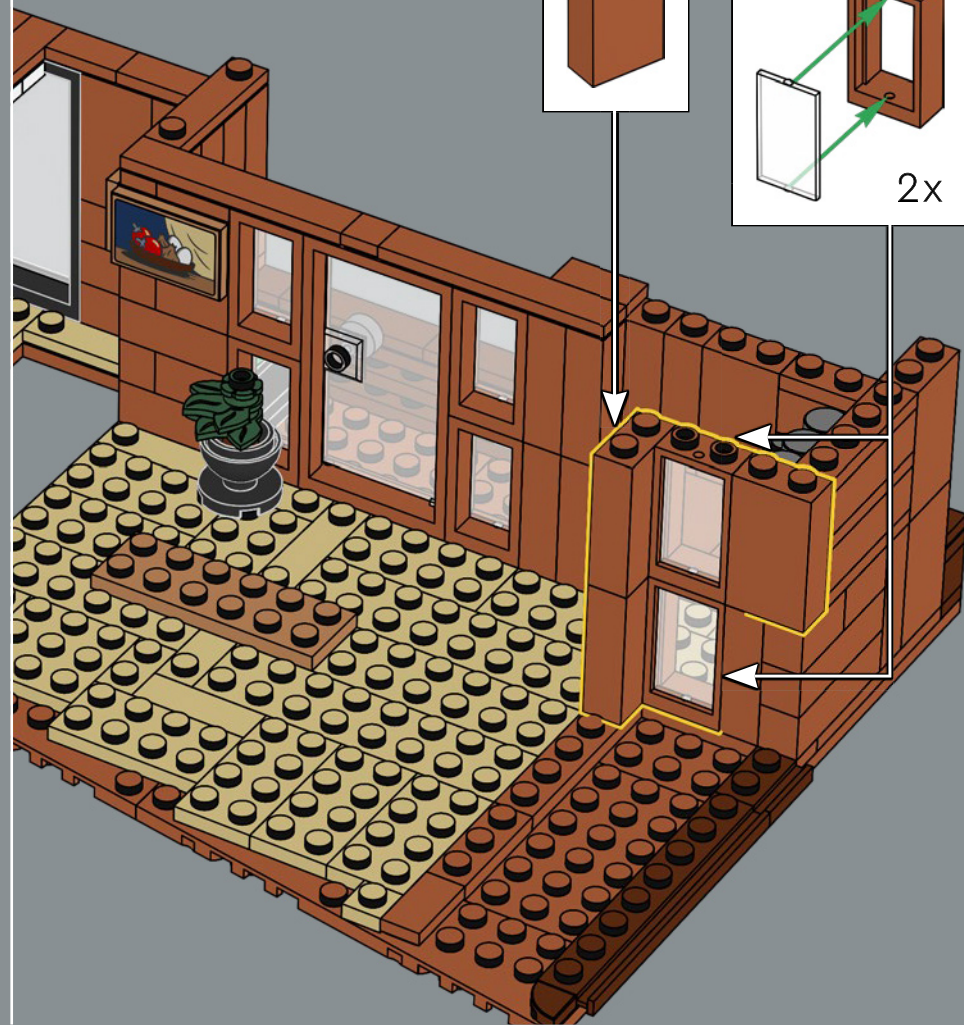

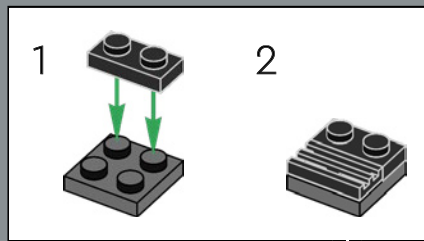
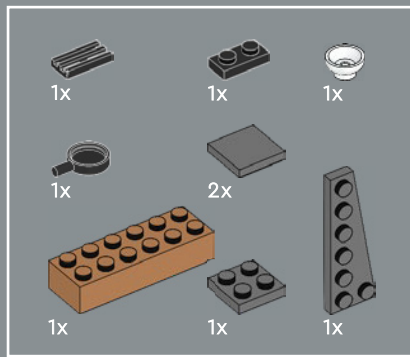

167

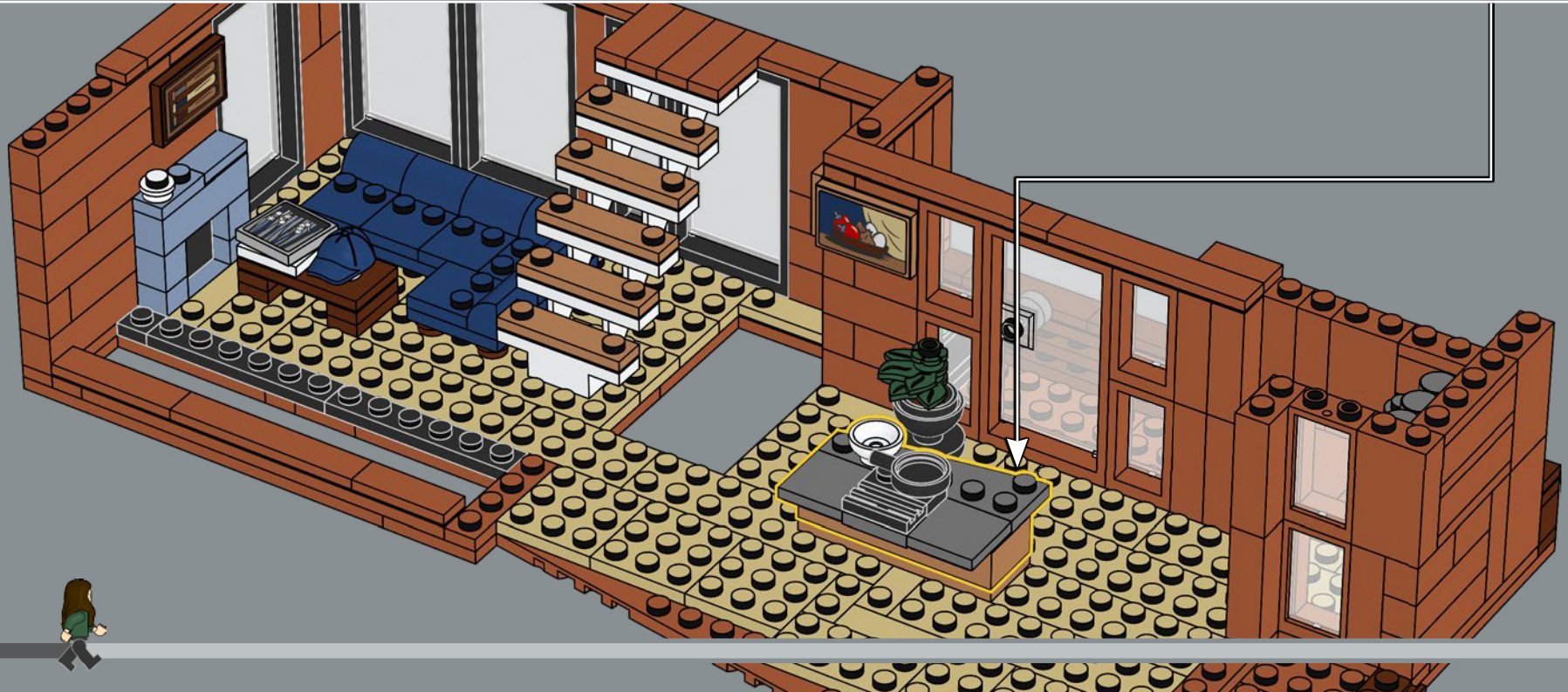
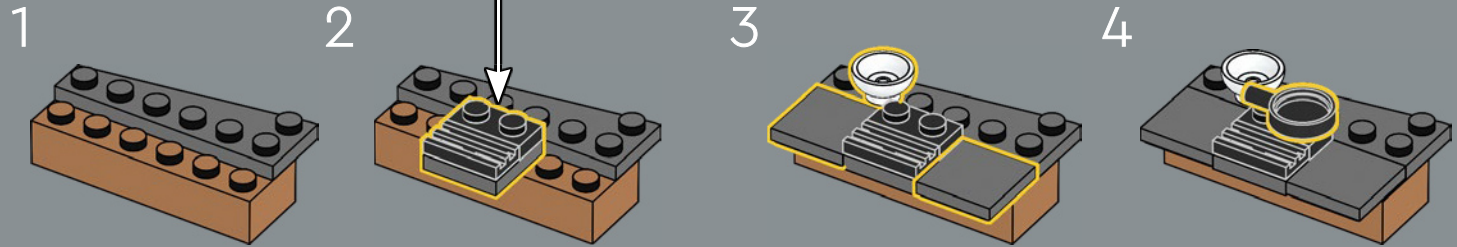

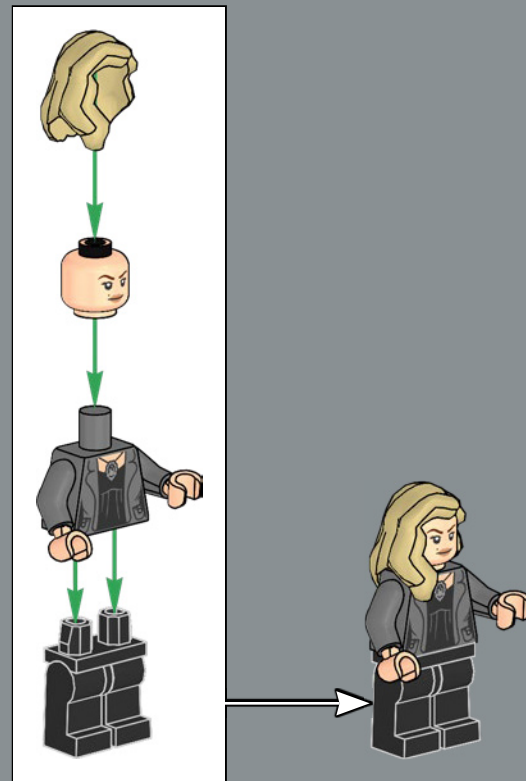

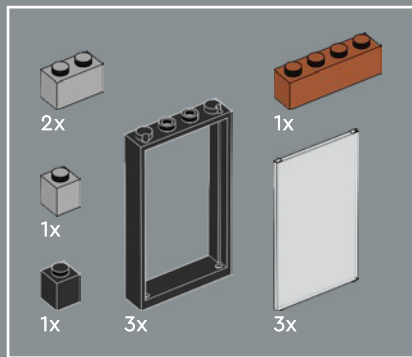

168

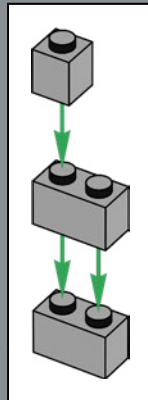
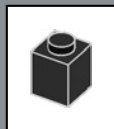
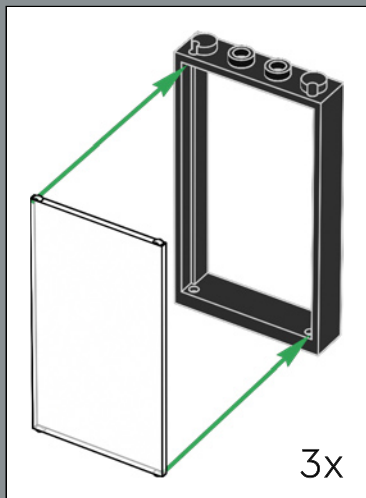

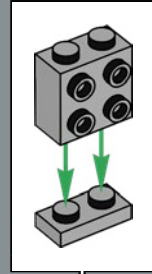
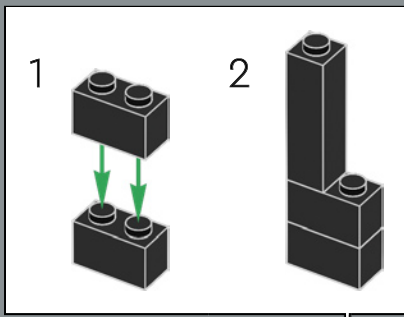
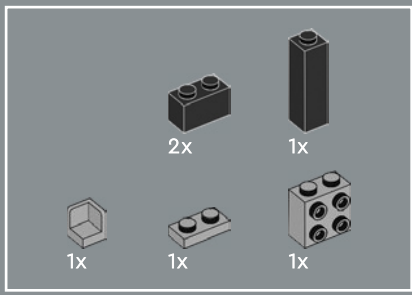

169



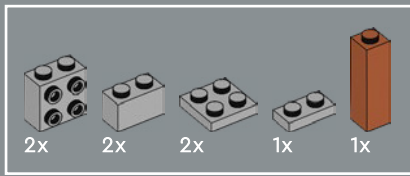

170

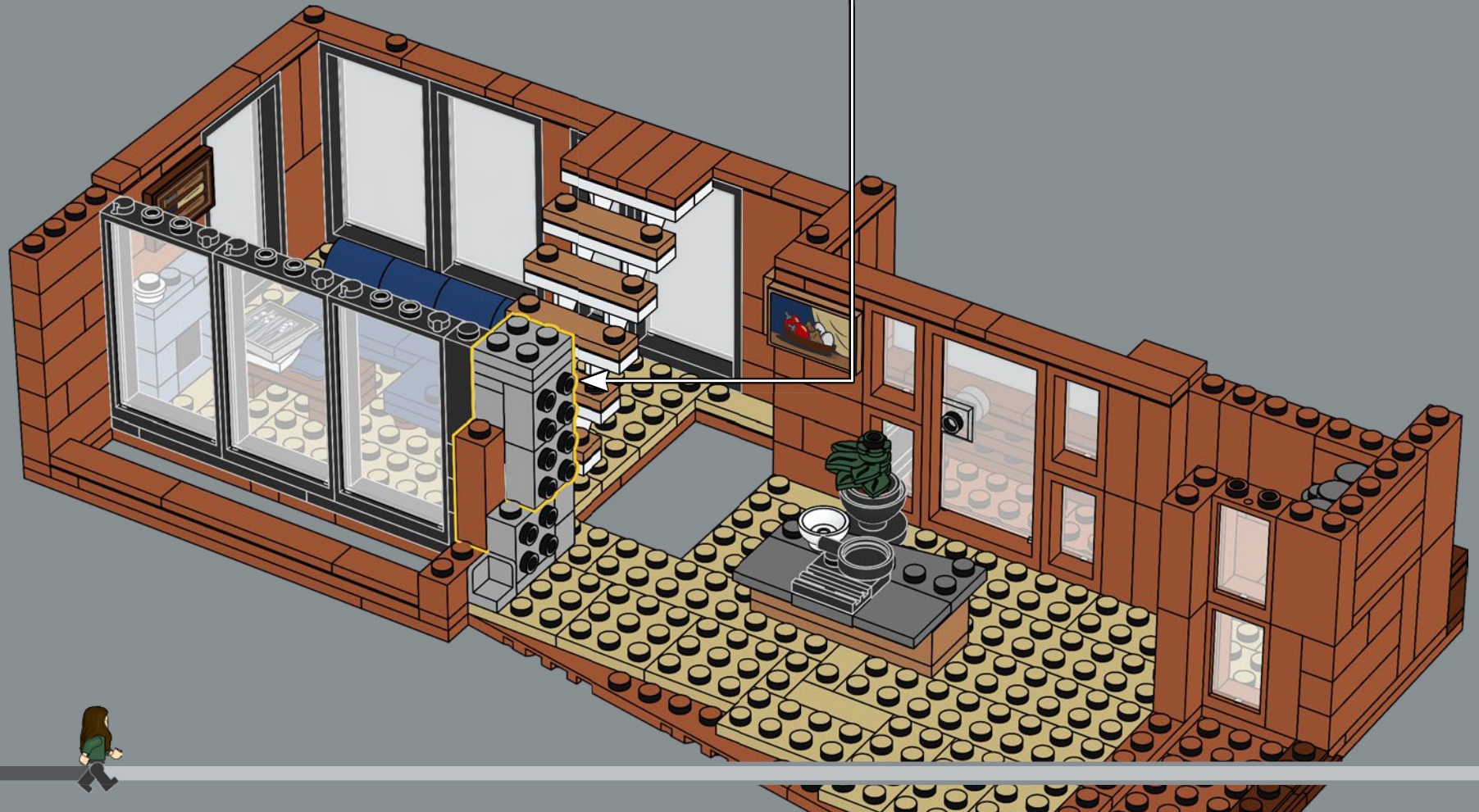
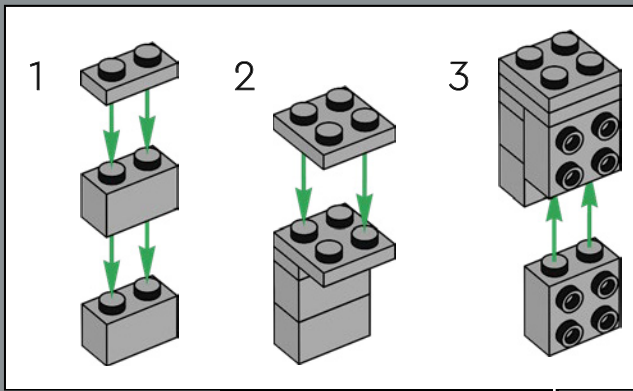

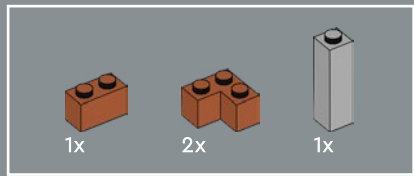

171

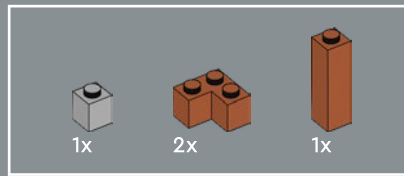
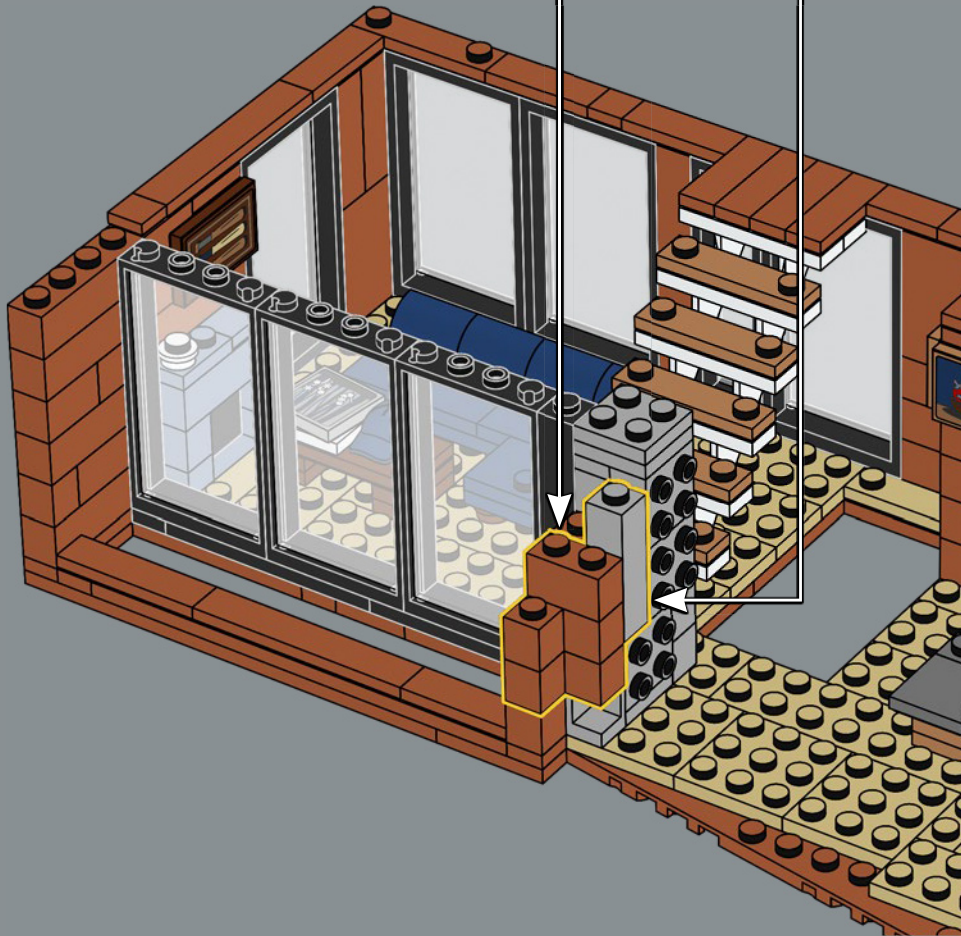
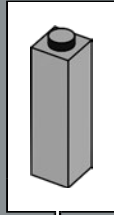
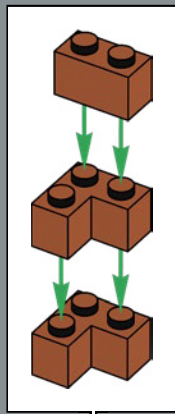

172

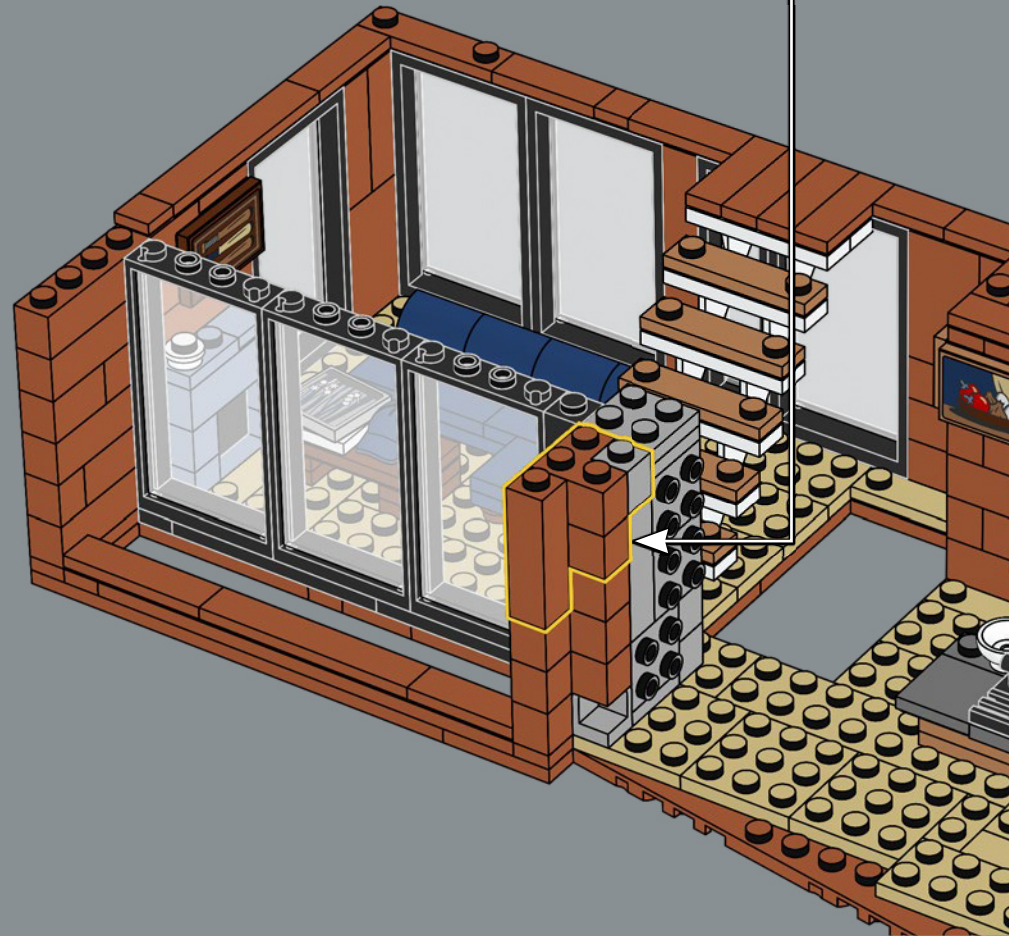
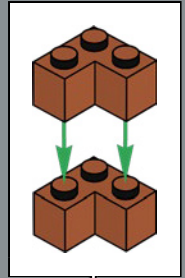

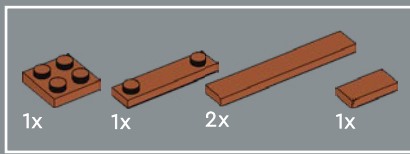

173

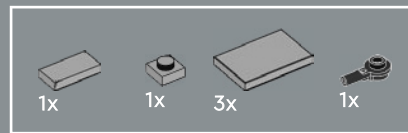
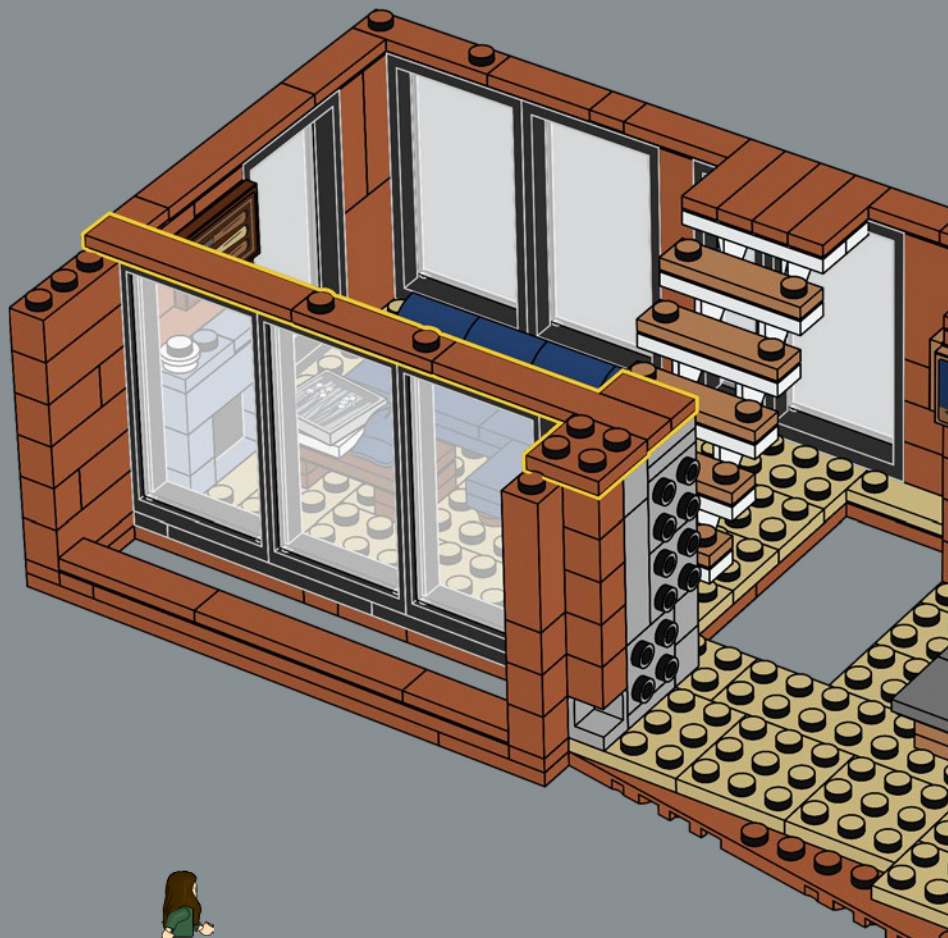

174

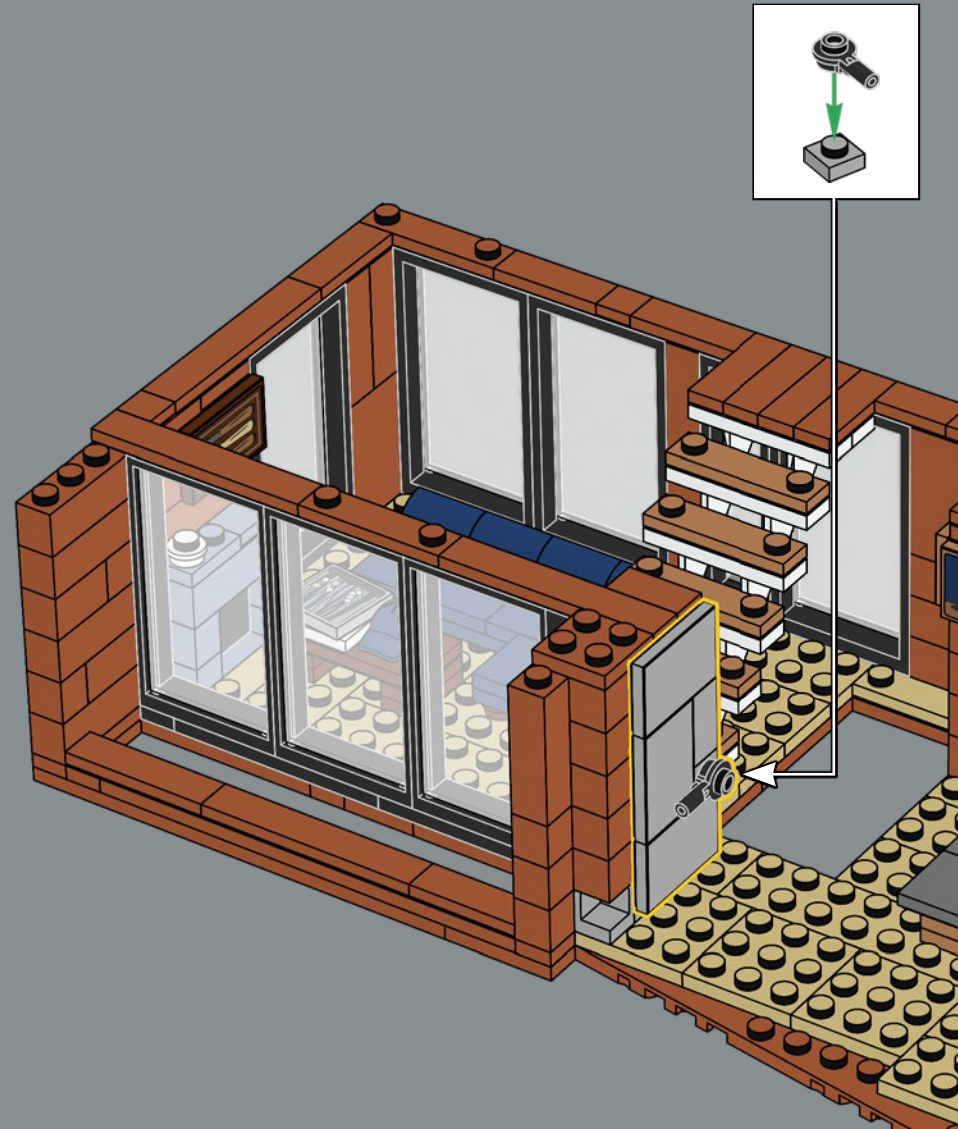

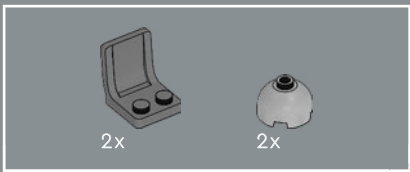

175

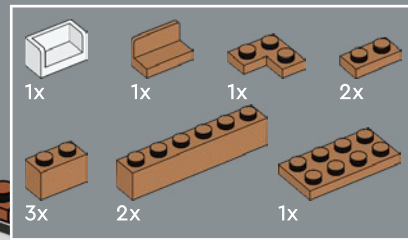
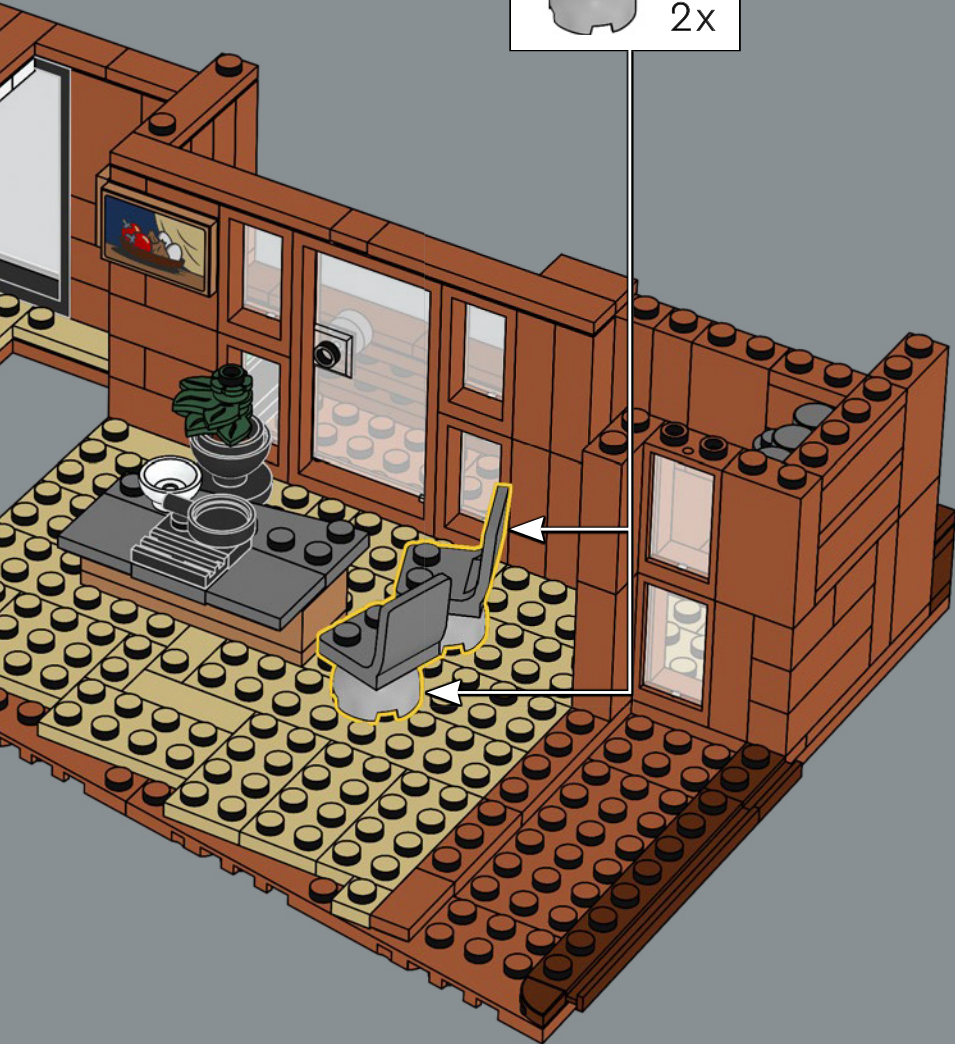
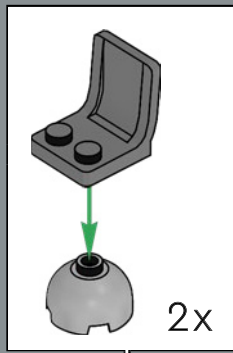

176

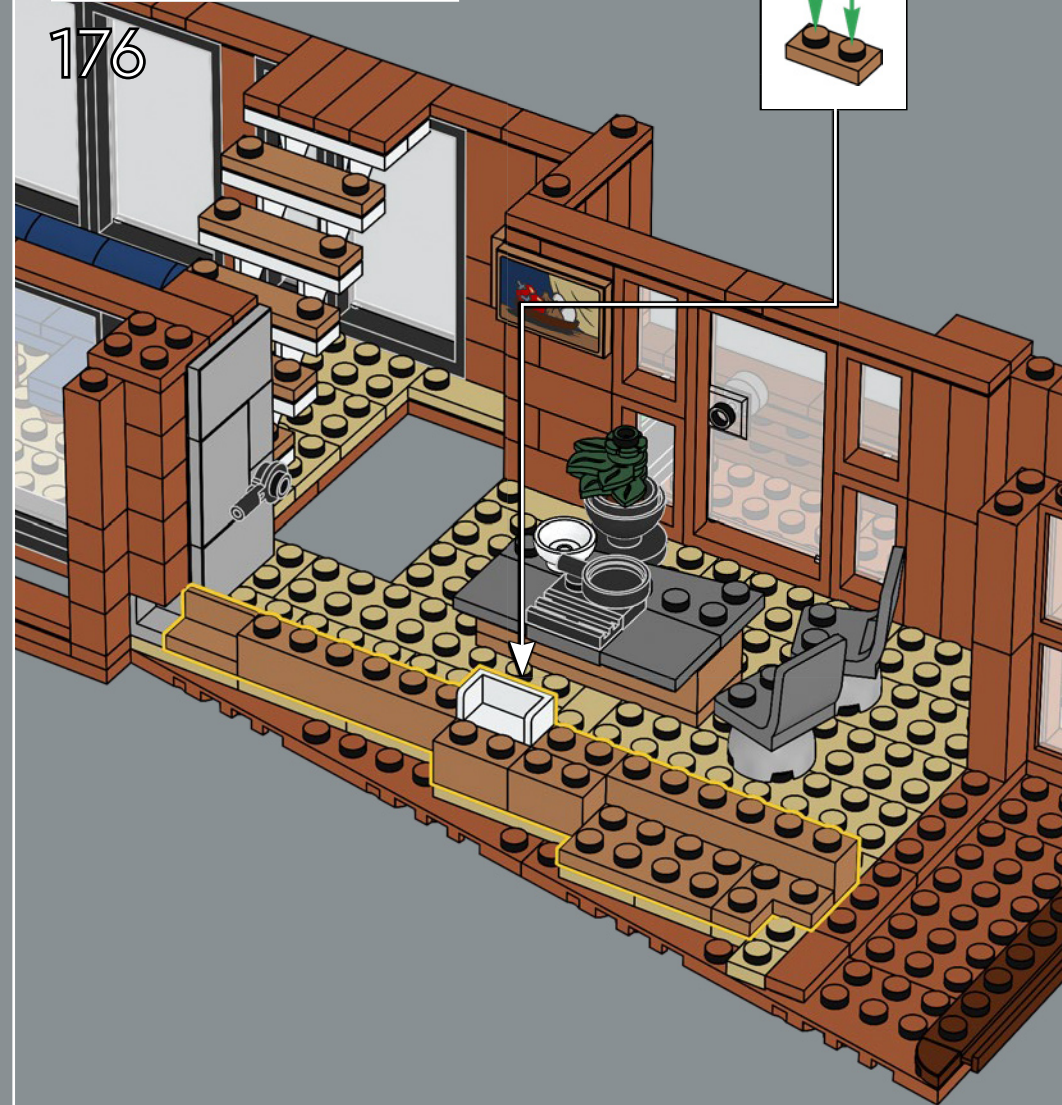
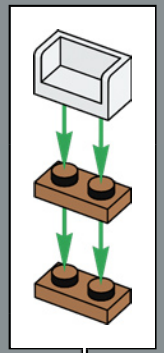

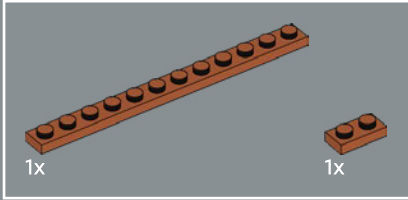
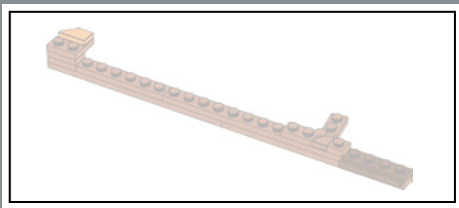

177

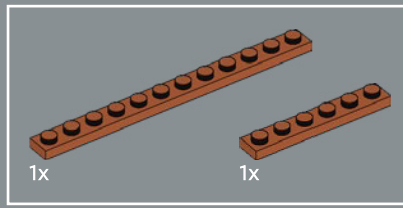
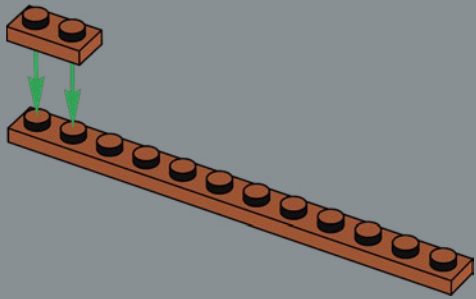

178

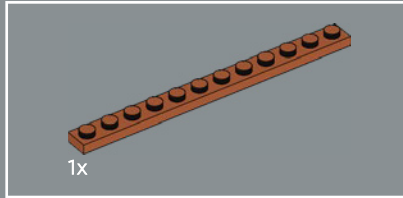
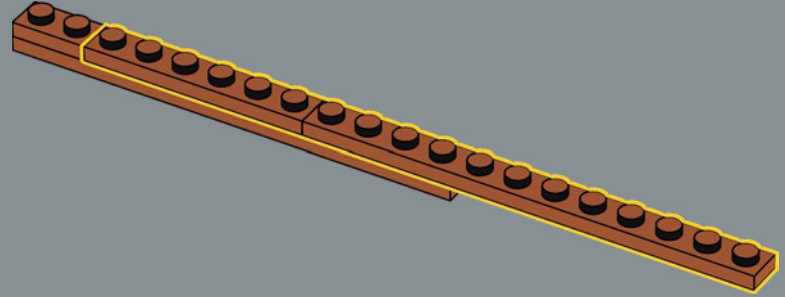

179

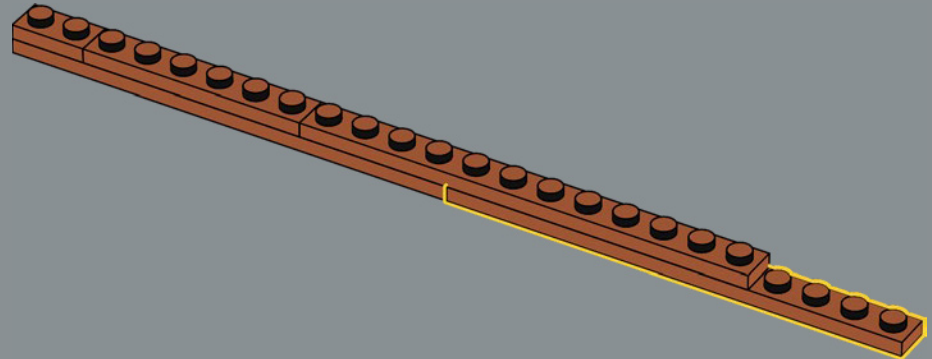

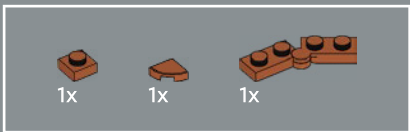

180

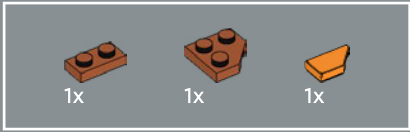
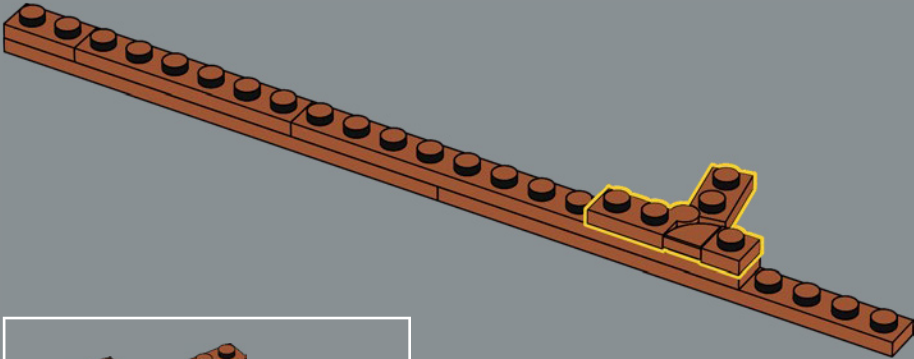

181

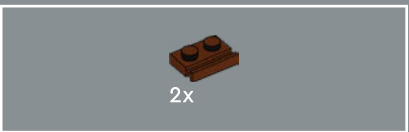
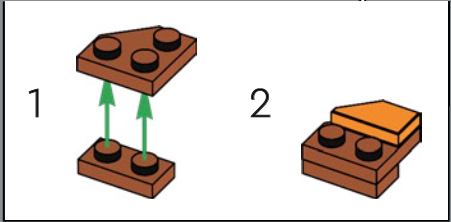
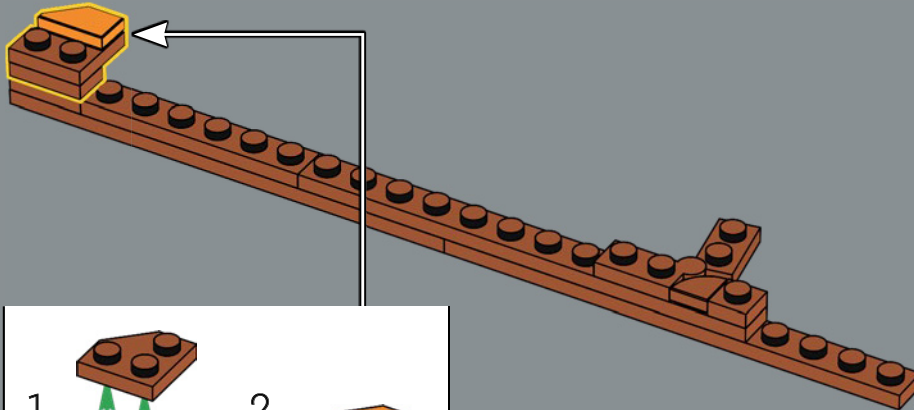

182

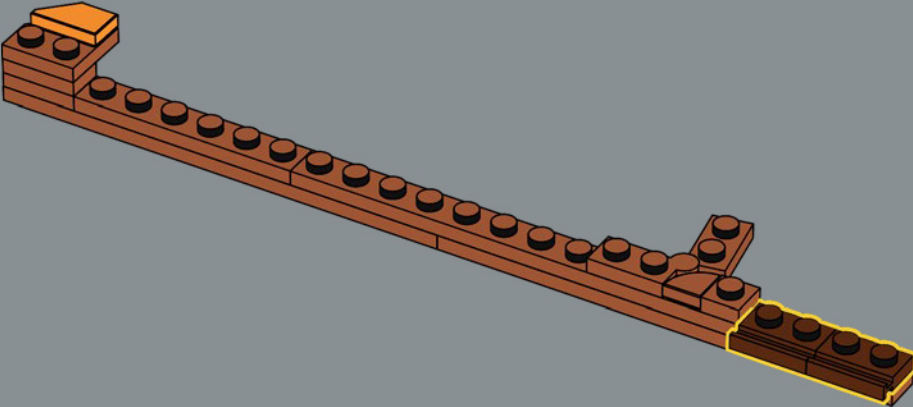

183

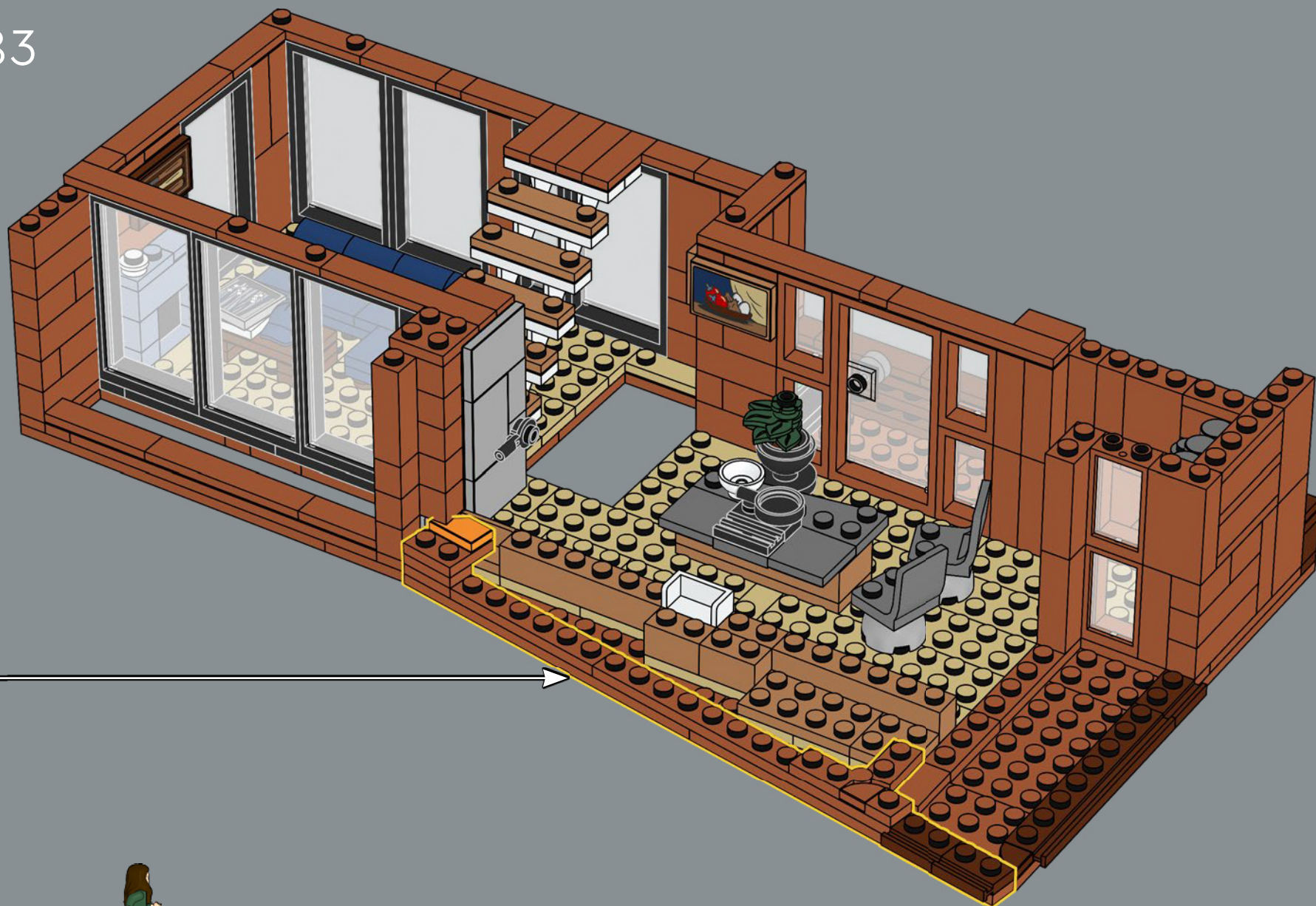

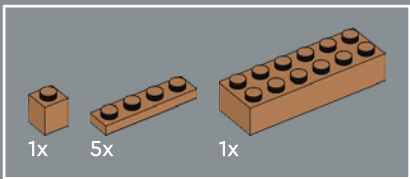

184

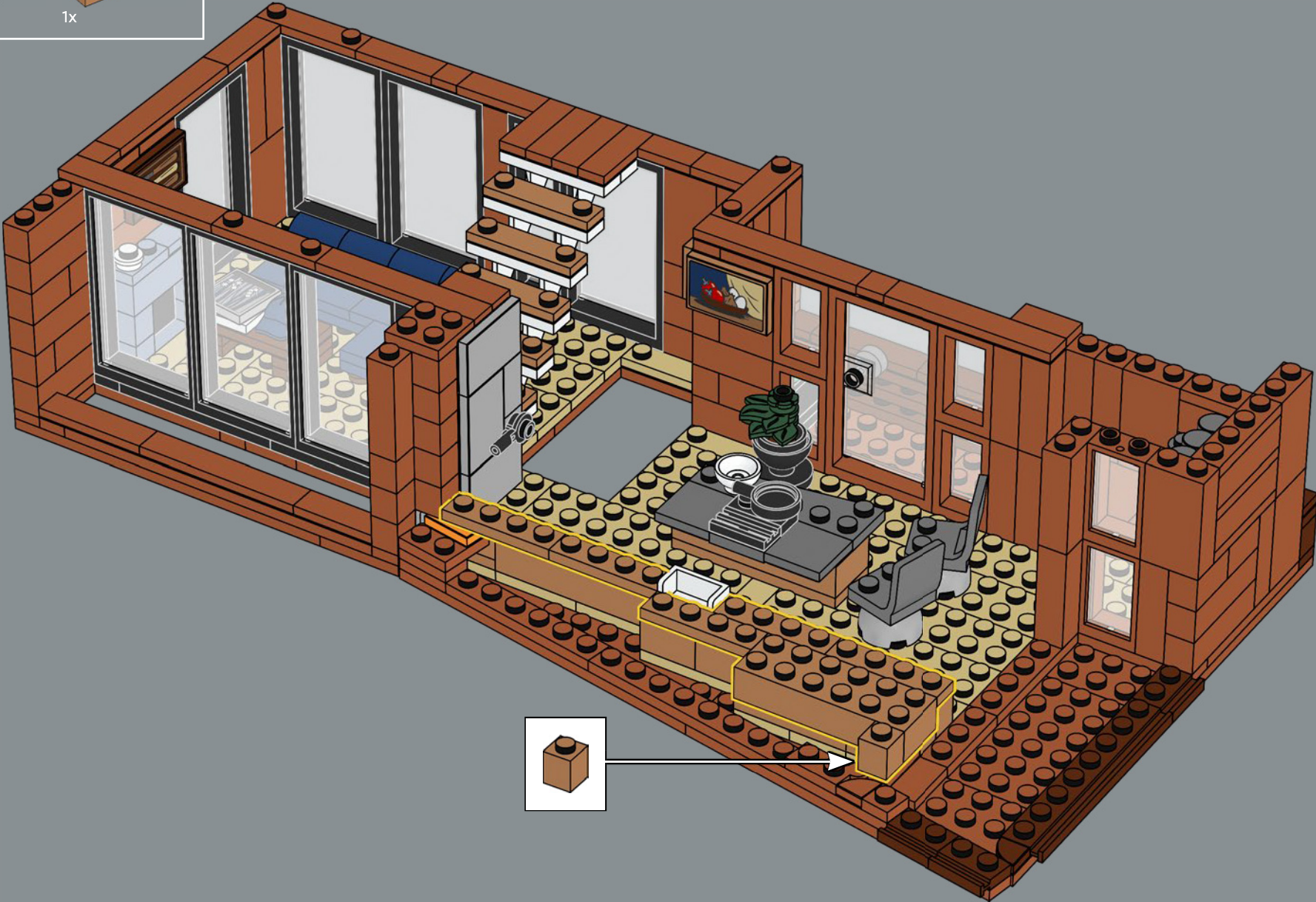

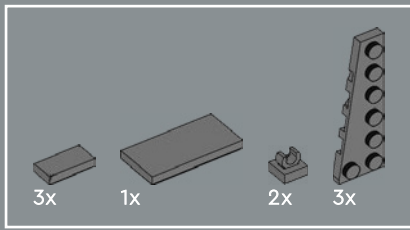

185

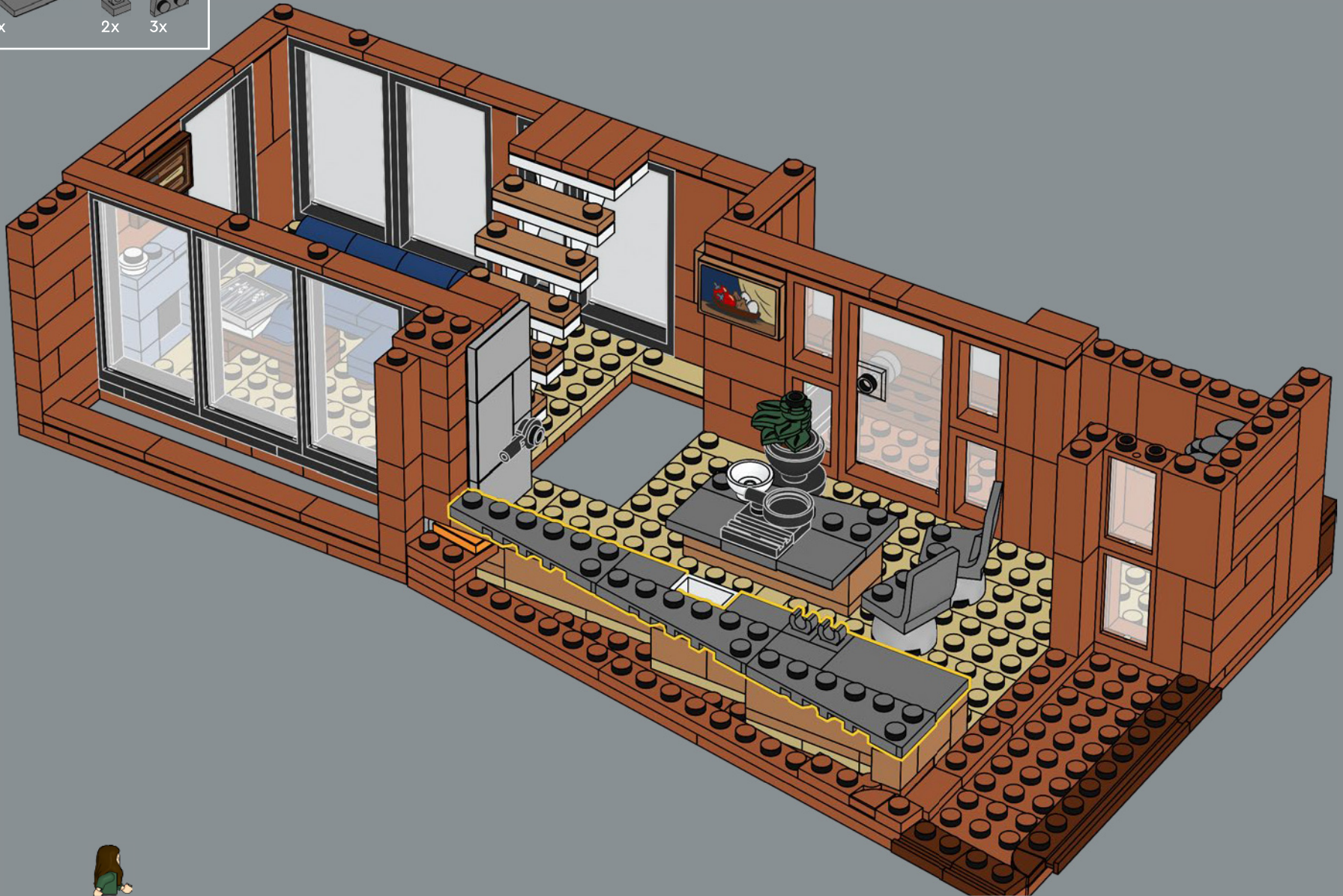

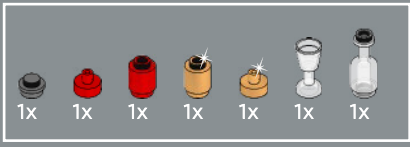

186

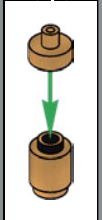
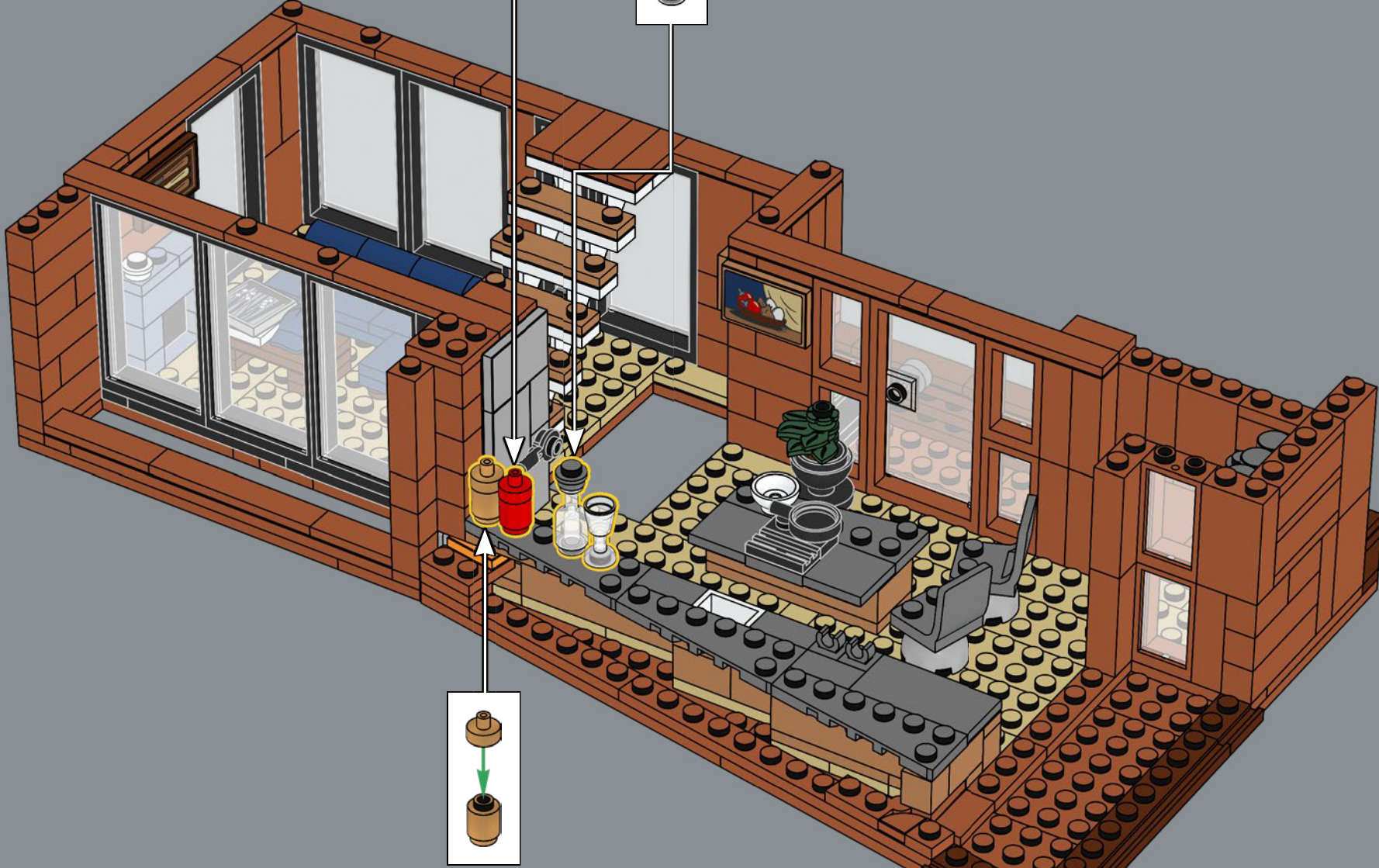
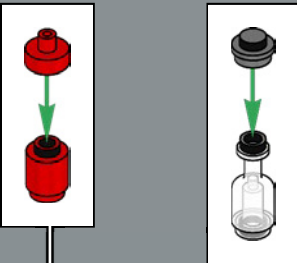

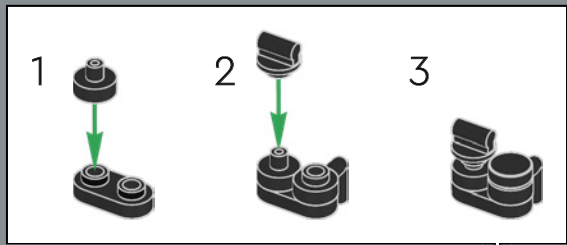
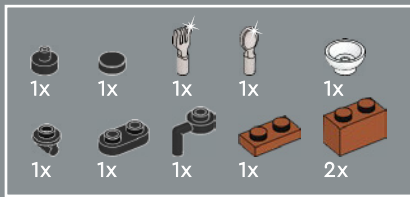

187

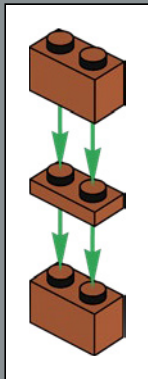
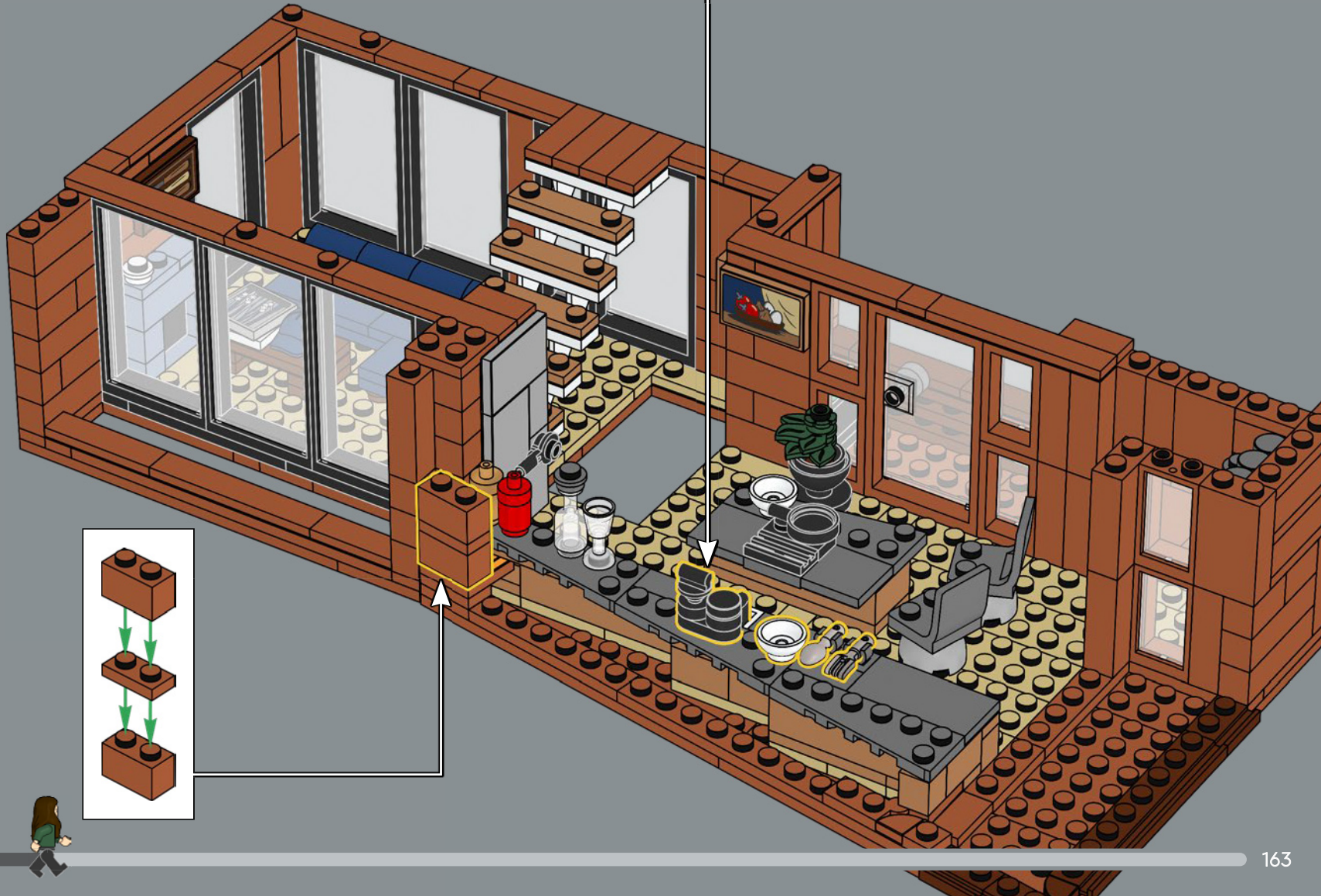

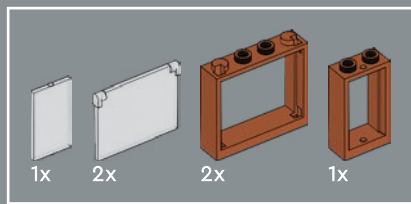

188

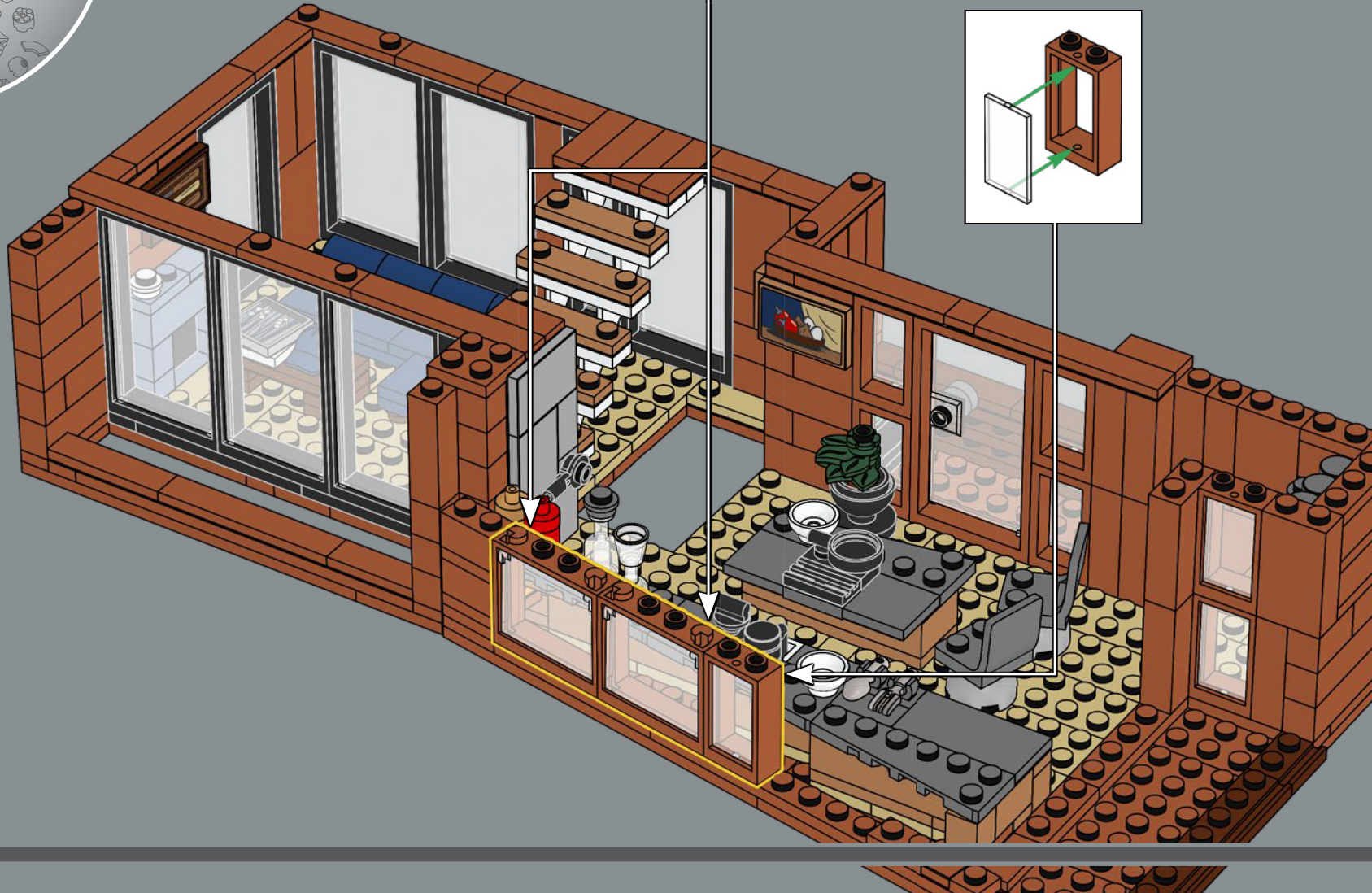
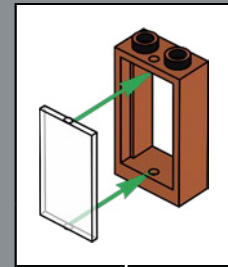
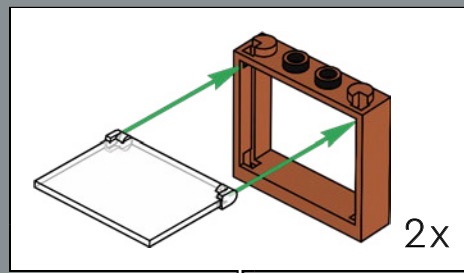

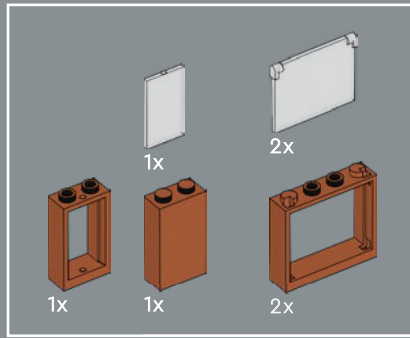

189

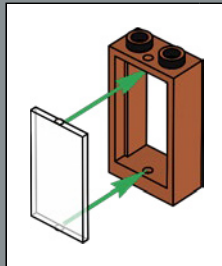
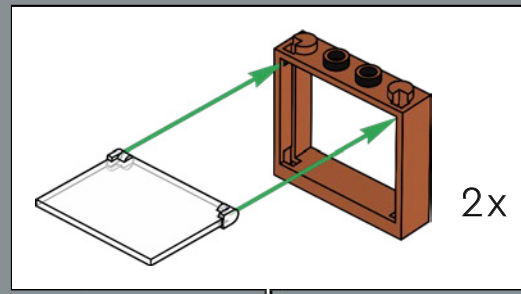

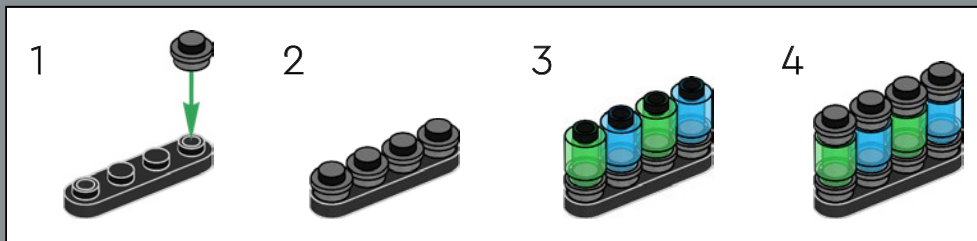
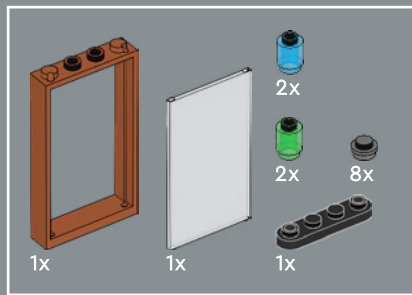

190

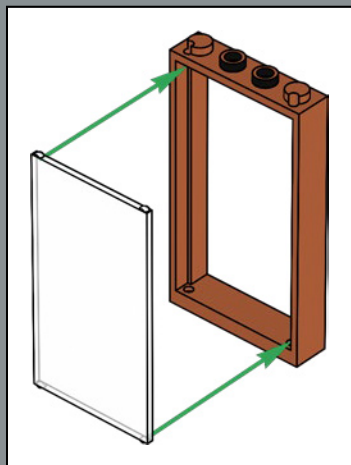

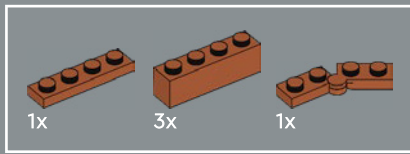

191

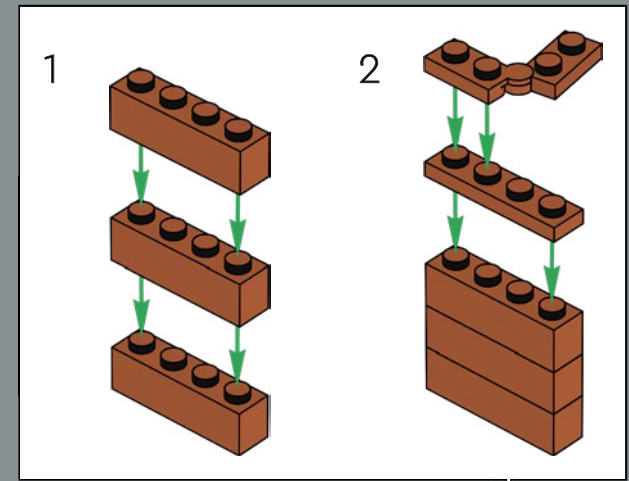

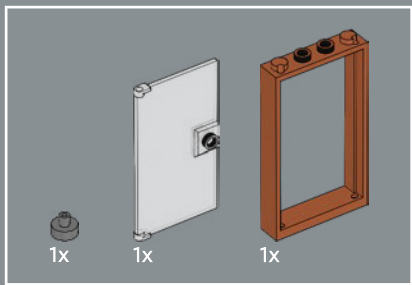

192

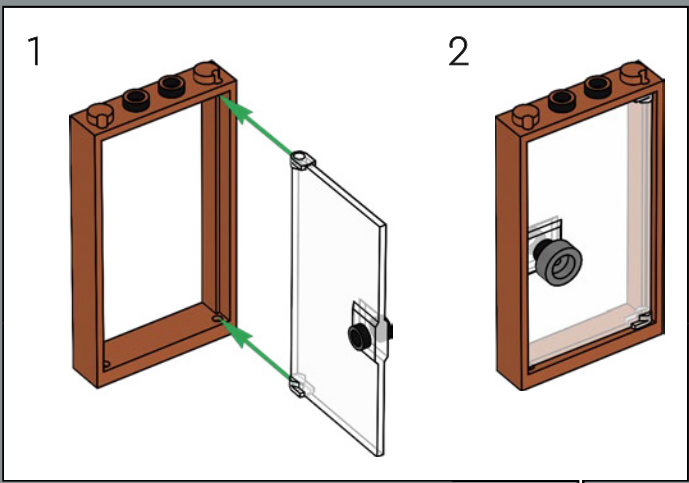

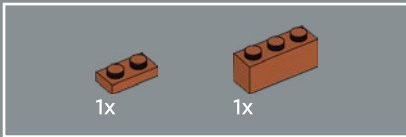
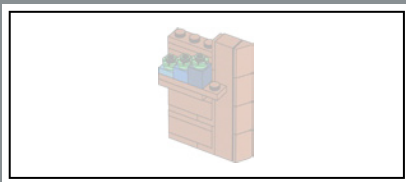

193

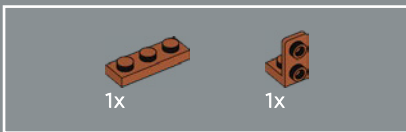
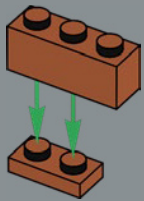

194

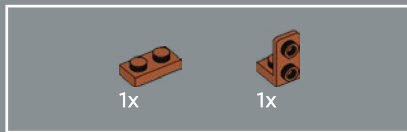
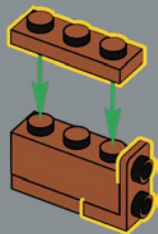

195

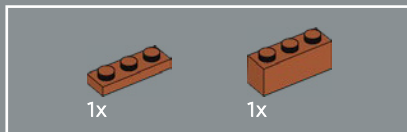
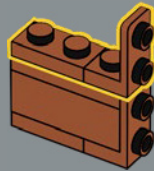

196

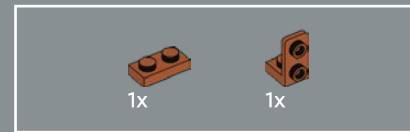
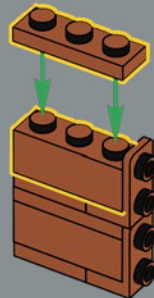

197

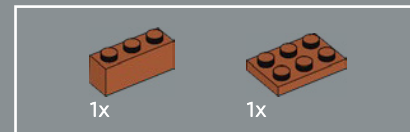
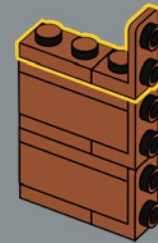

198

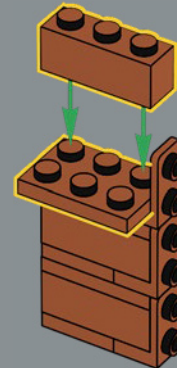

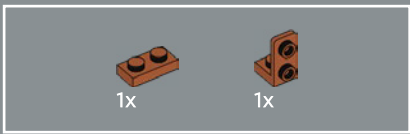

199

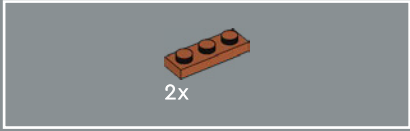
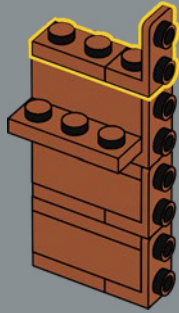

200

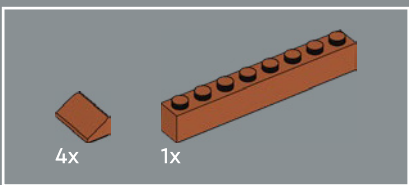
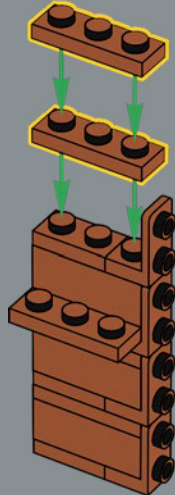

201

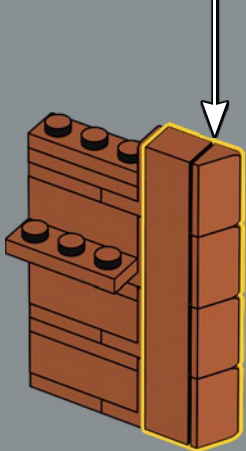
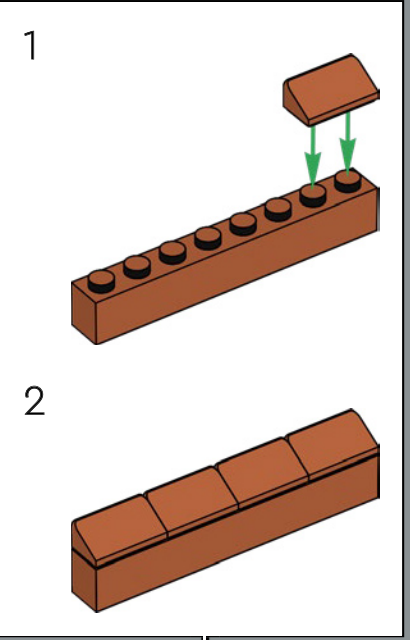

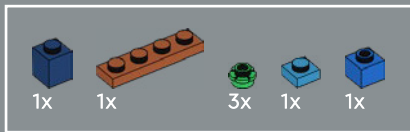

202

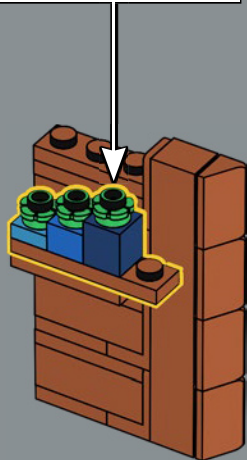
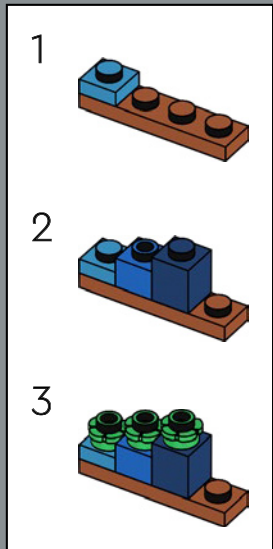

203

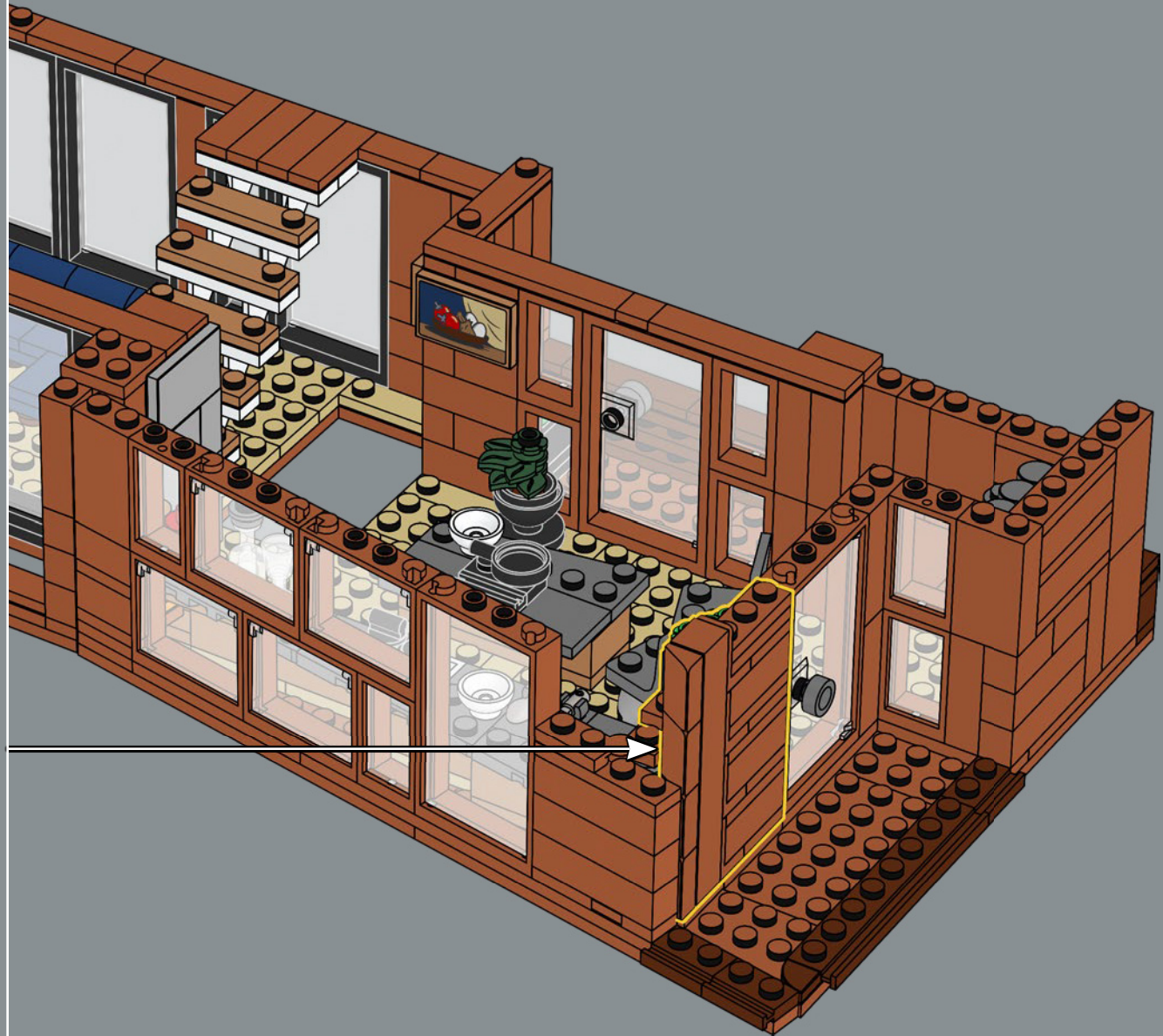

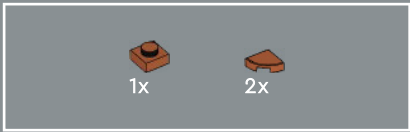

204

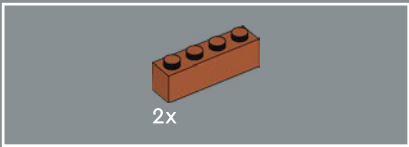

205

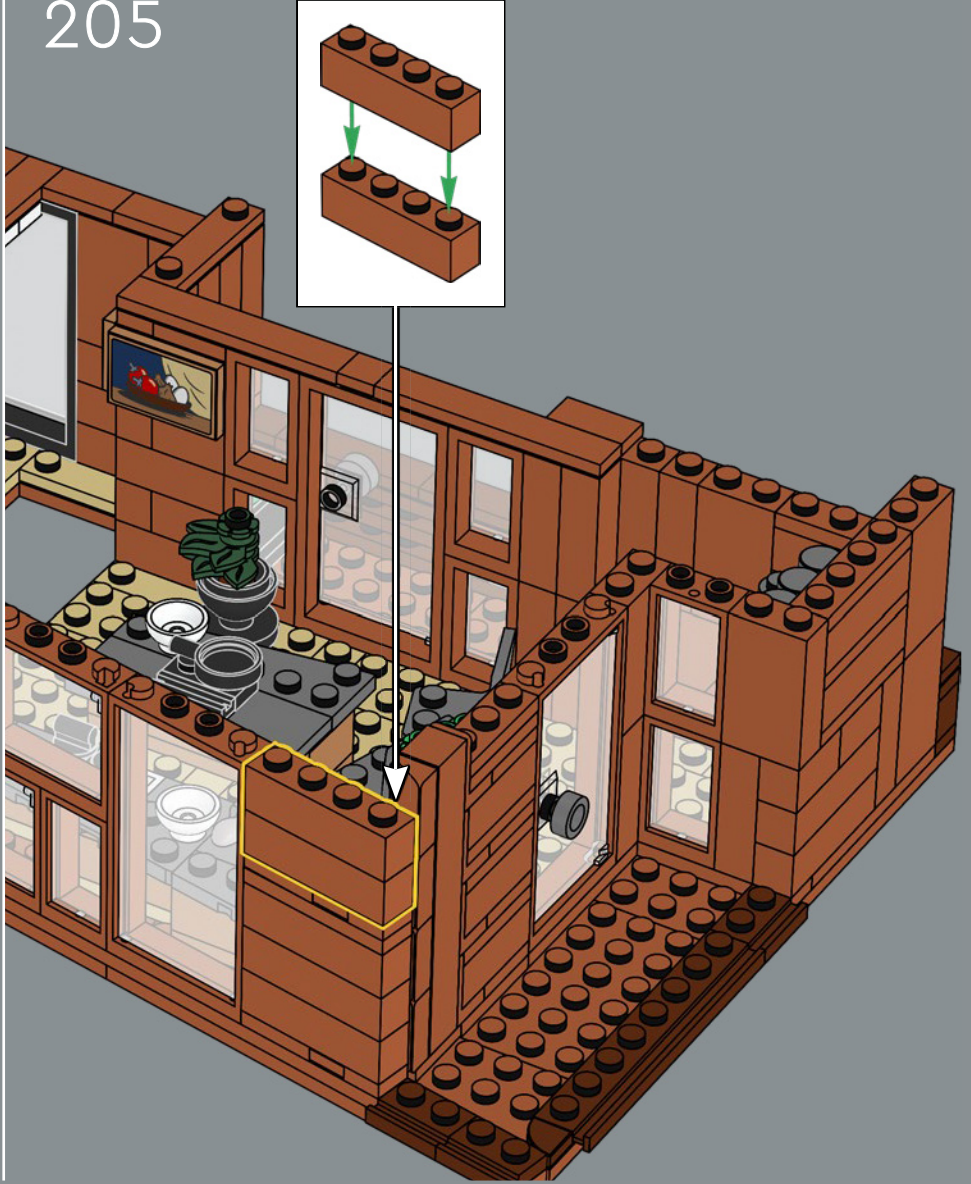

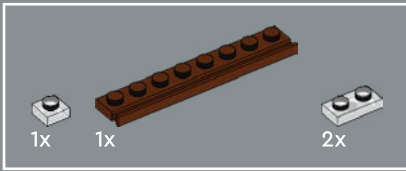
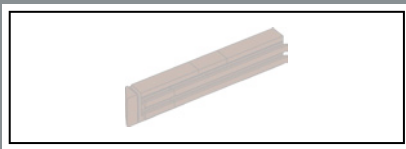

206

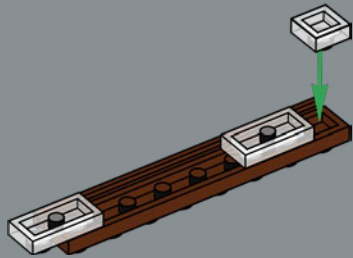

207

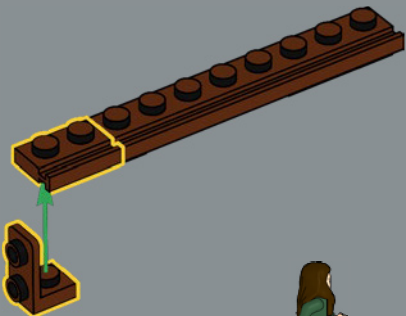

208

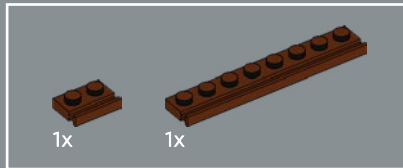
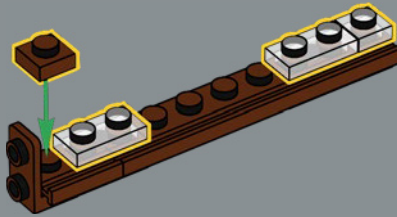

209

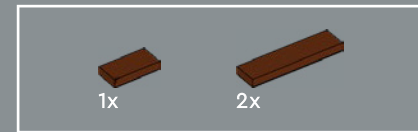
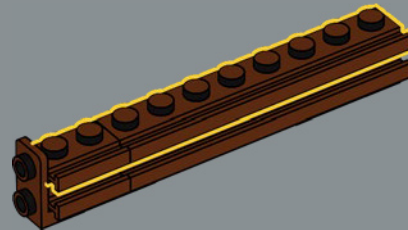

210

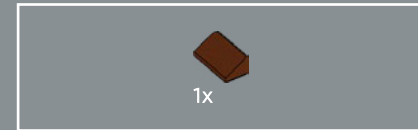
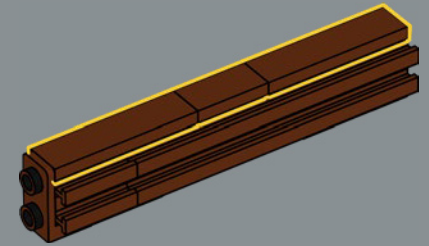

211

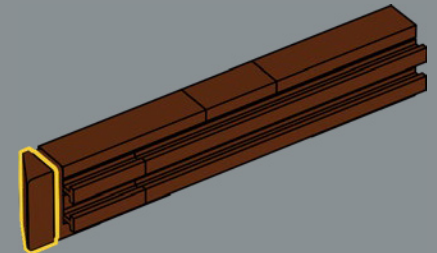

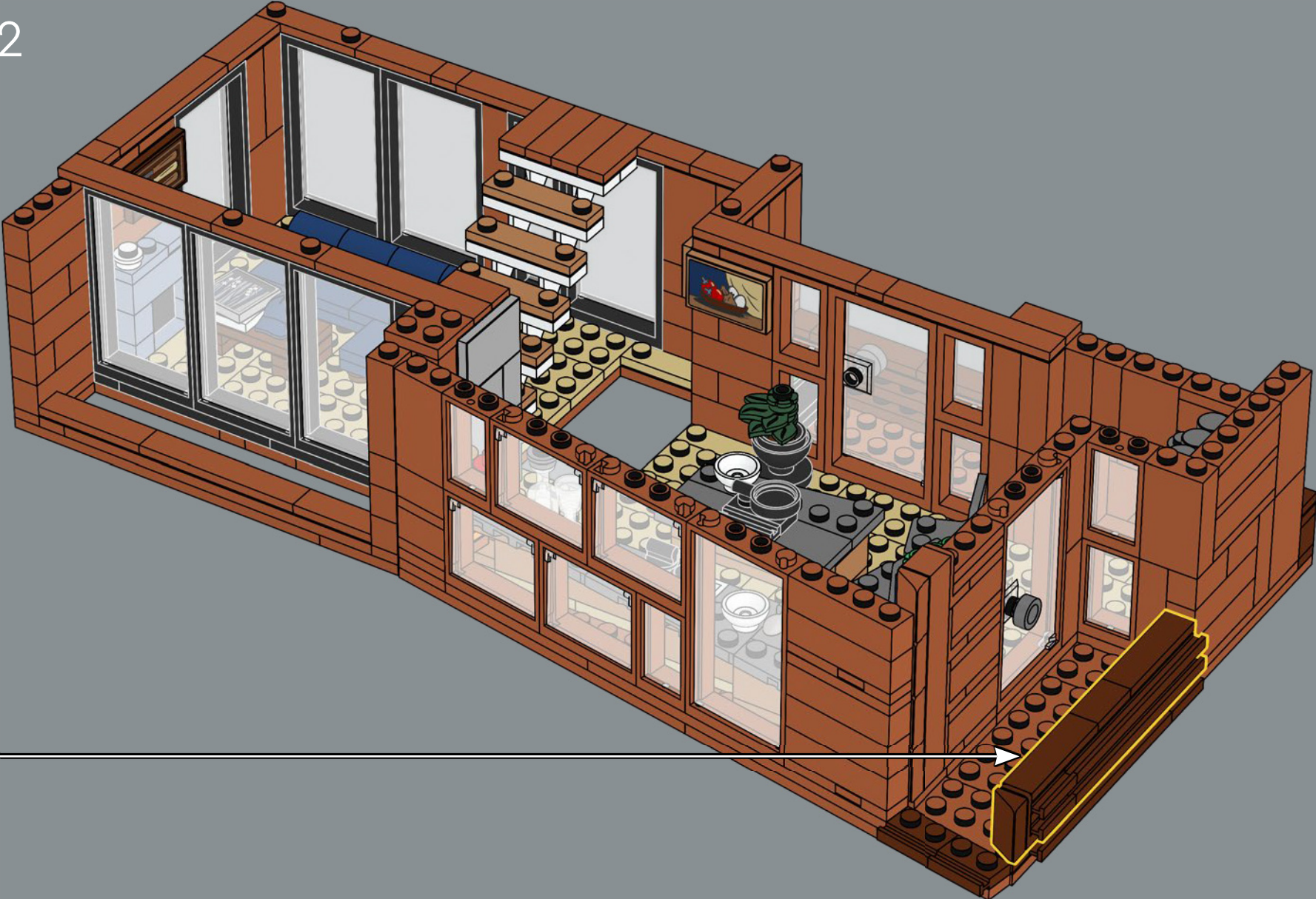

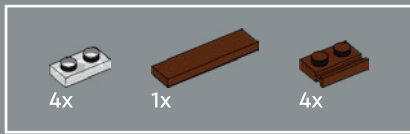

213

1

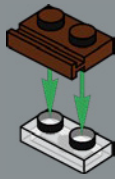

2



3

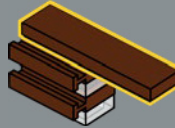

1

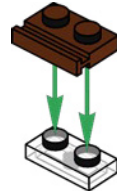

2

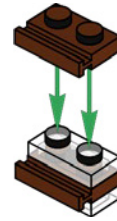

4

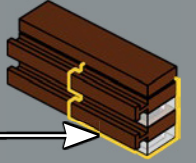

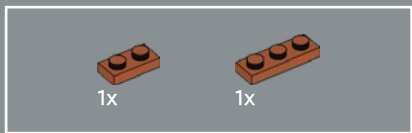

214

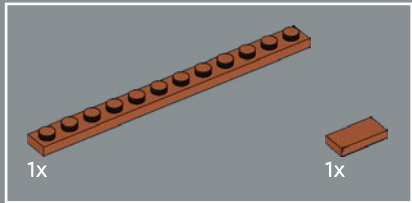
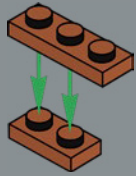

215

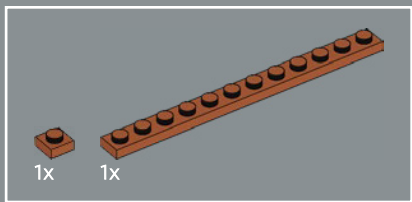
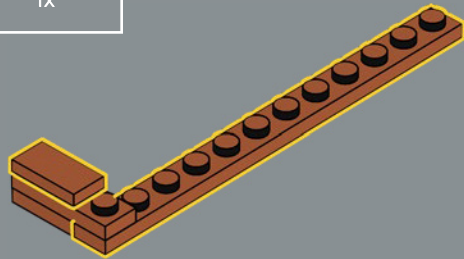

216

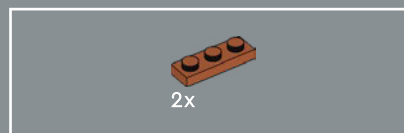
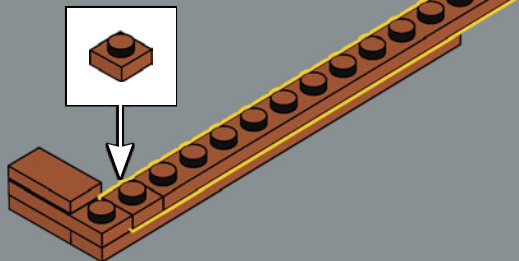

217

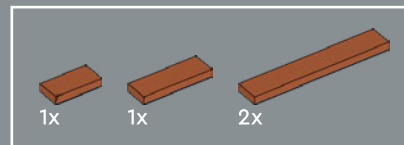
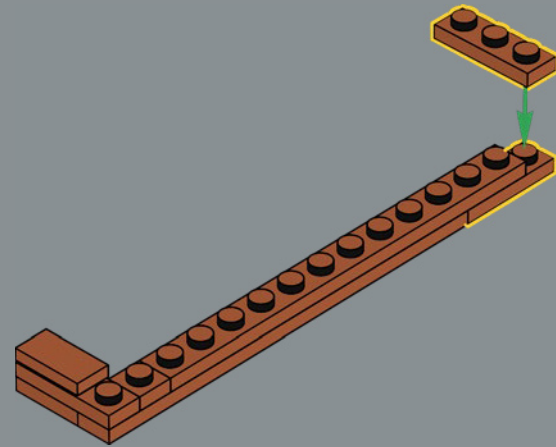

218

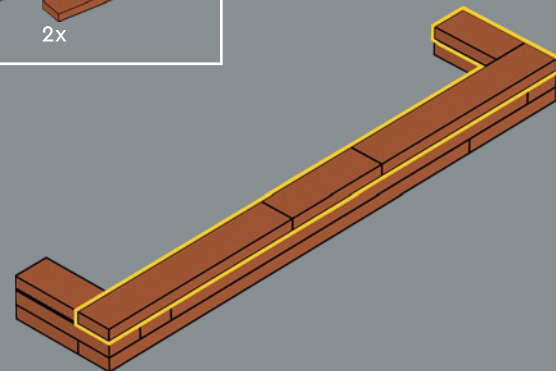

219



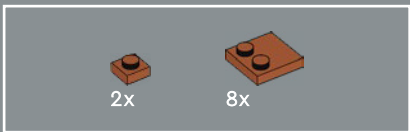

220

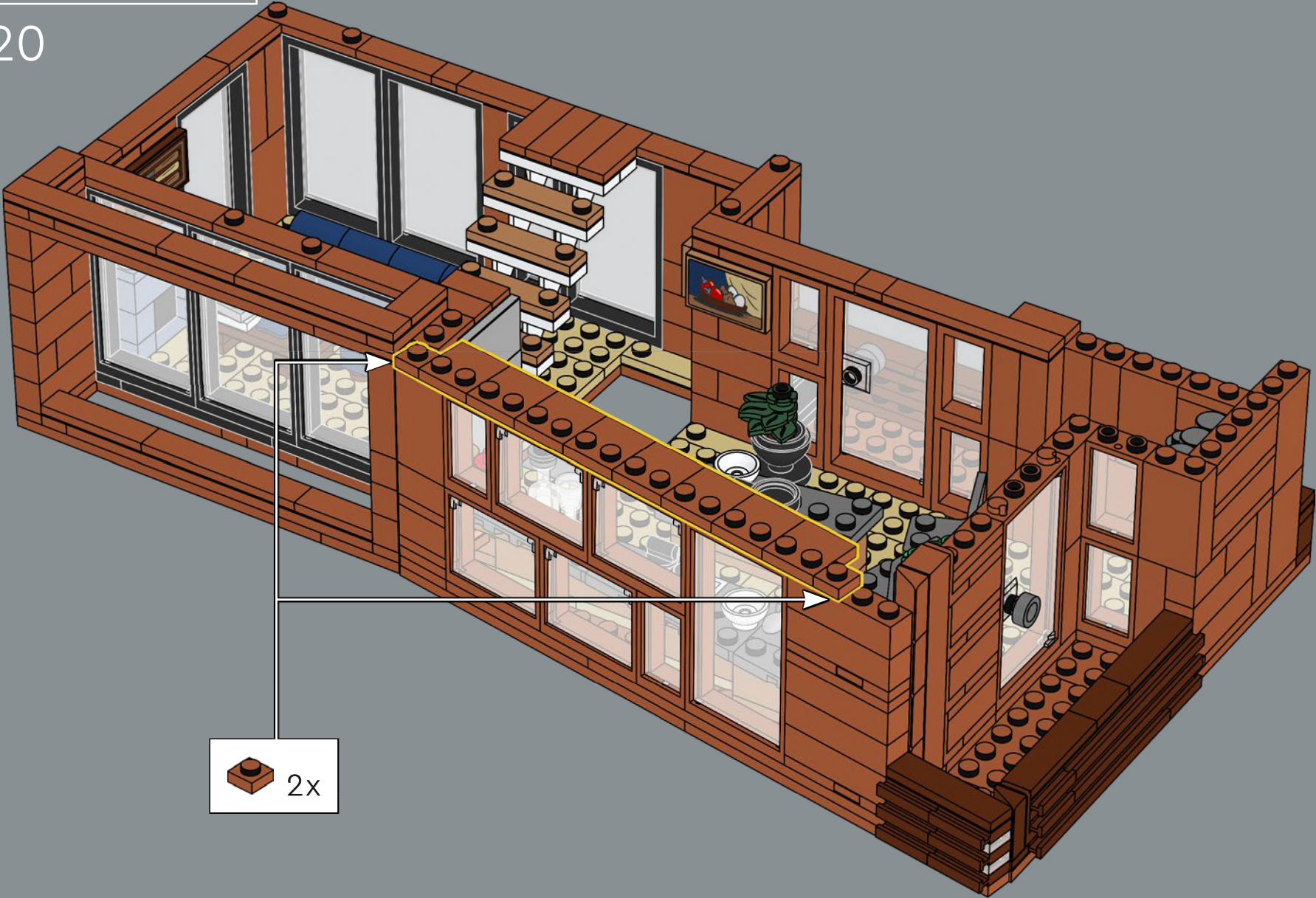

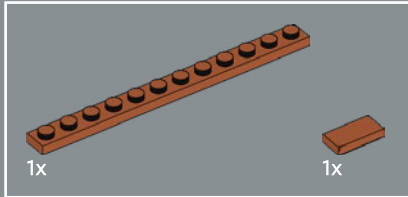
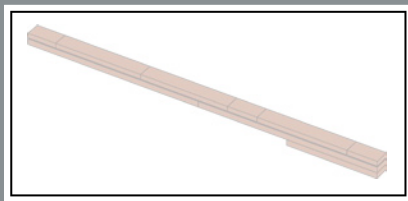

221

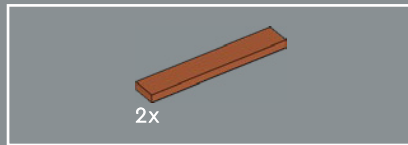
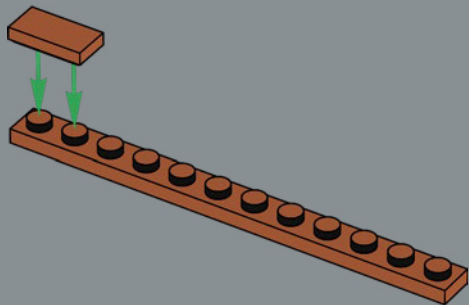

222

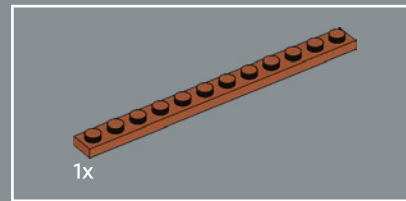
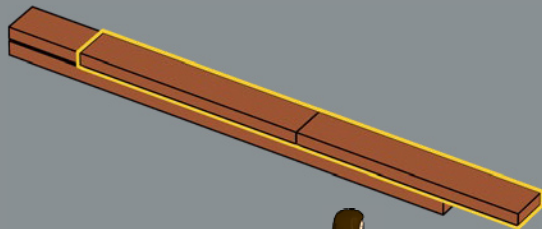

223

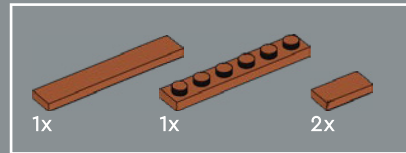
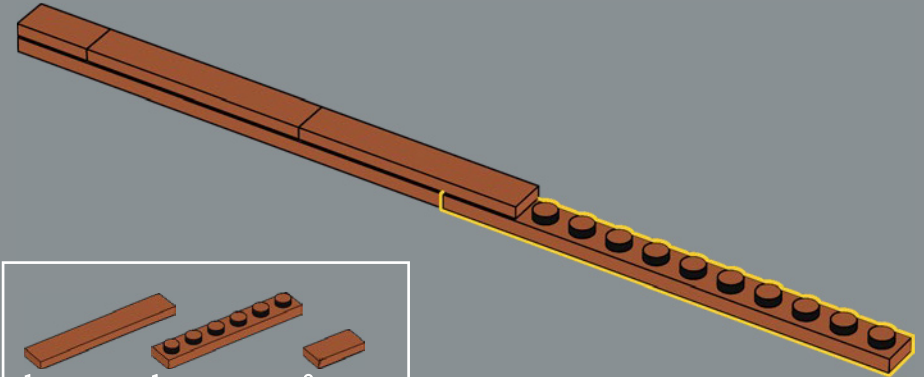

224

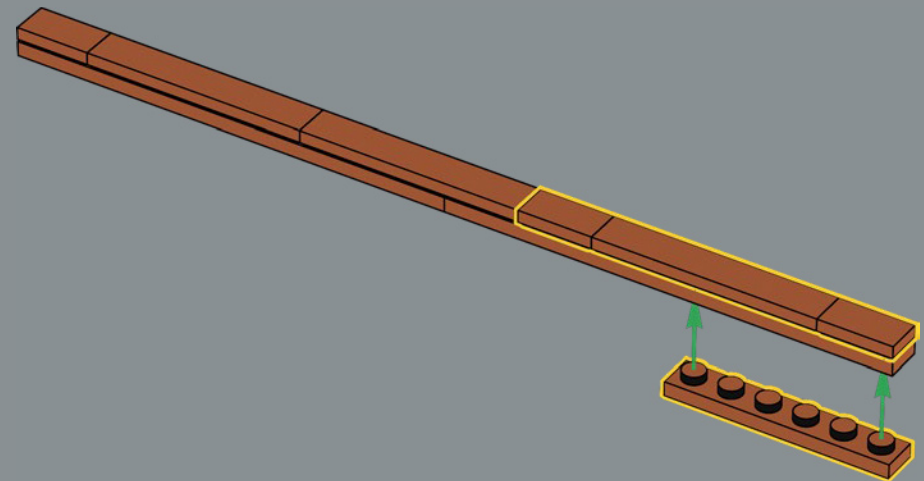

225

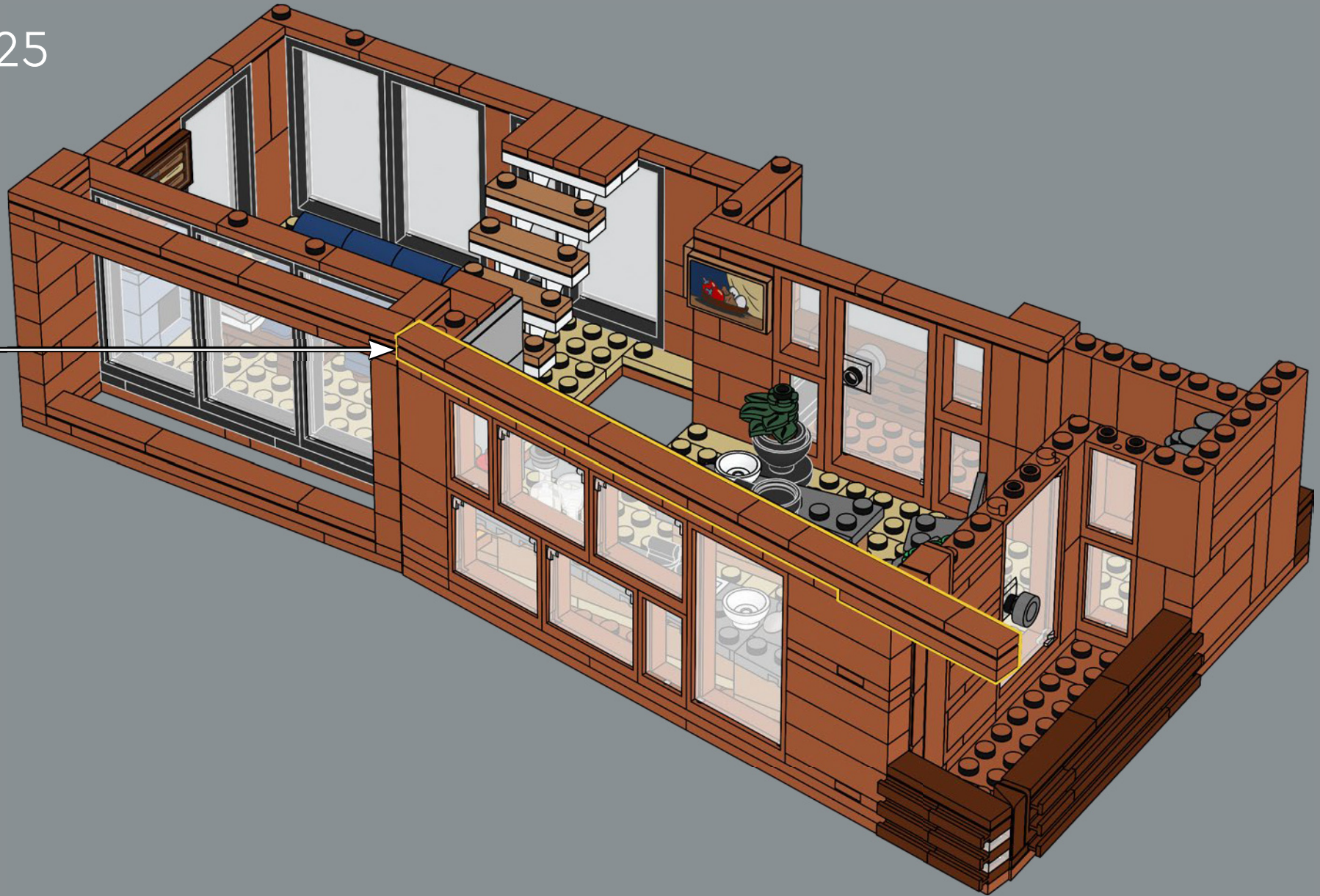

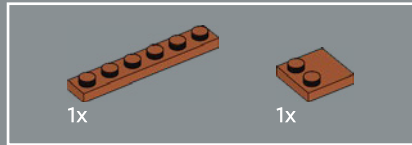
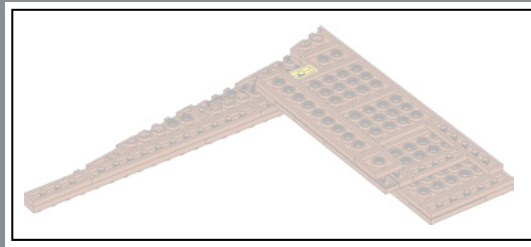

226

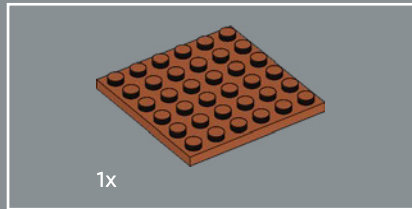
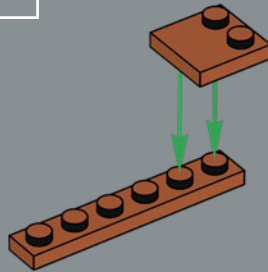

227

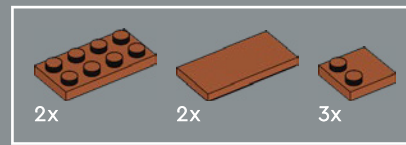
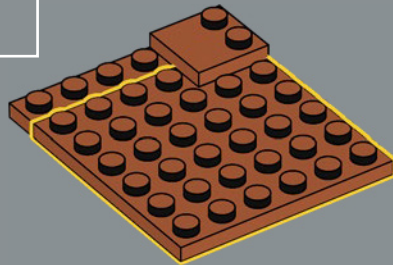

228

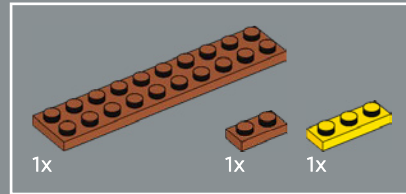
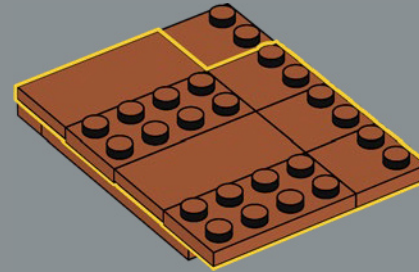

229

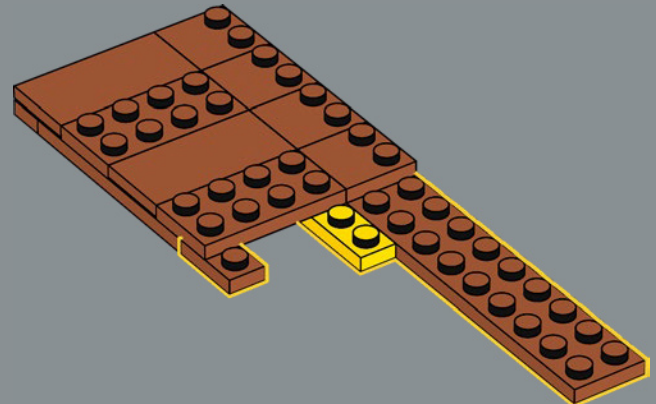

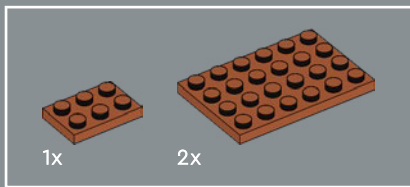

233

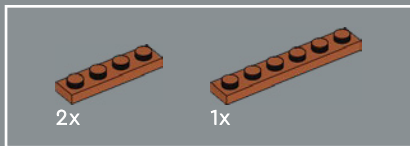
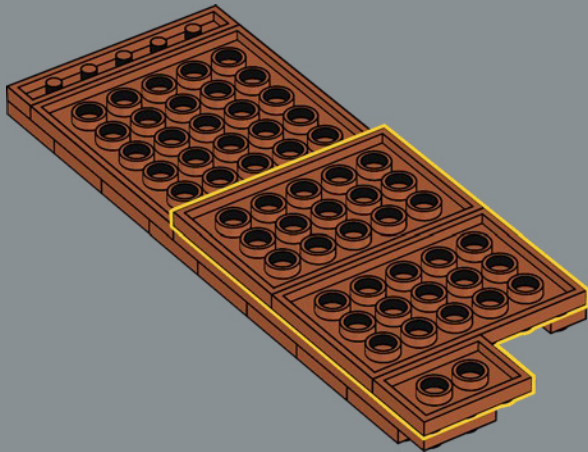

234

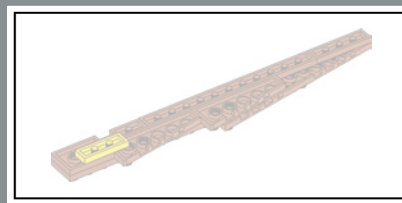
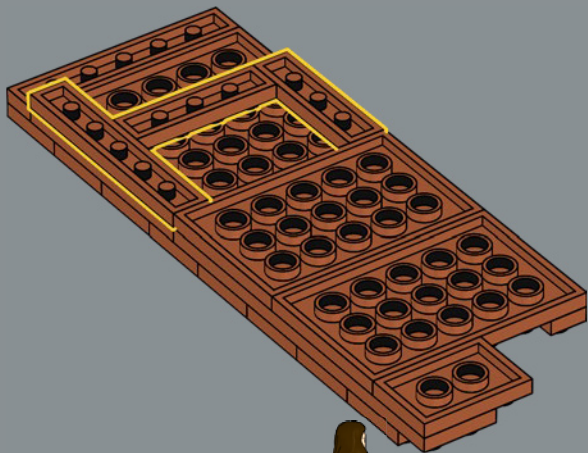

235

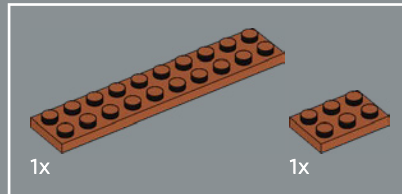

236

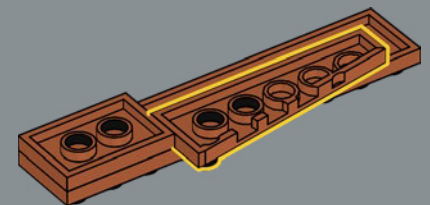
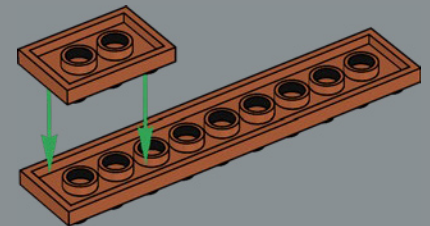
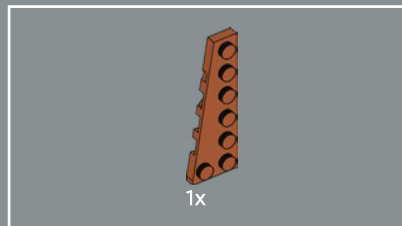

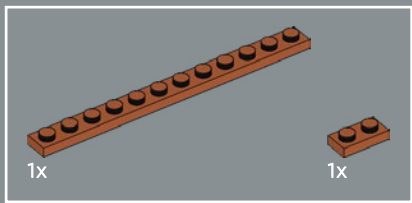

237

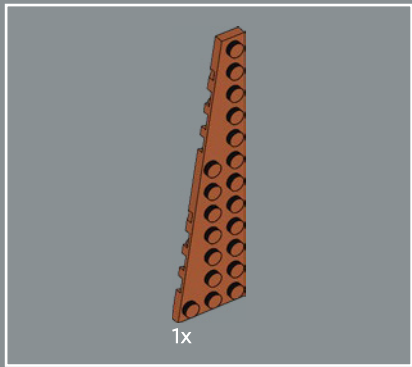
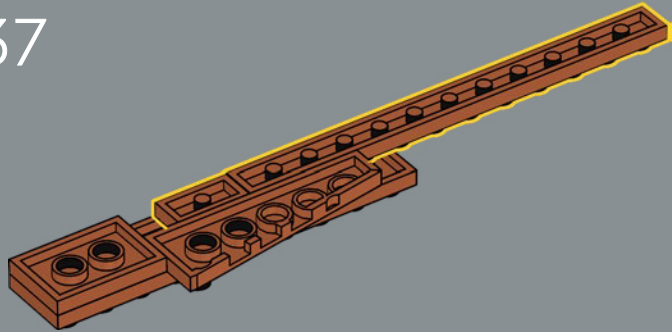

238

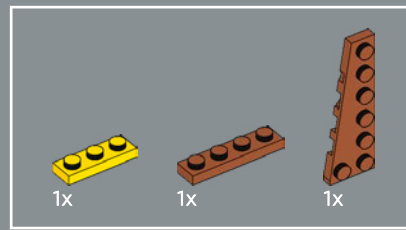
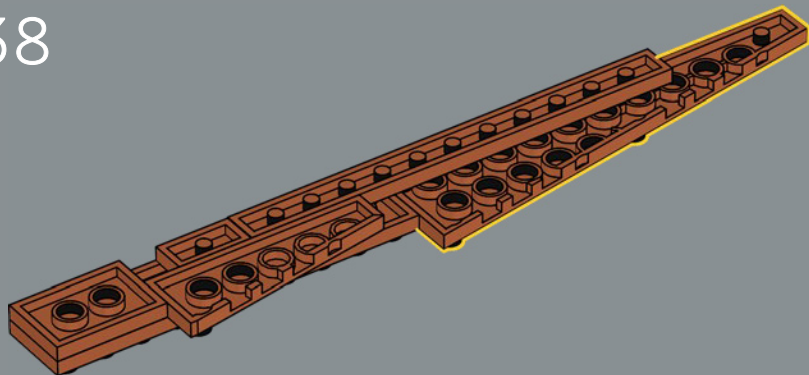

239

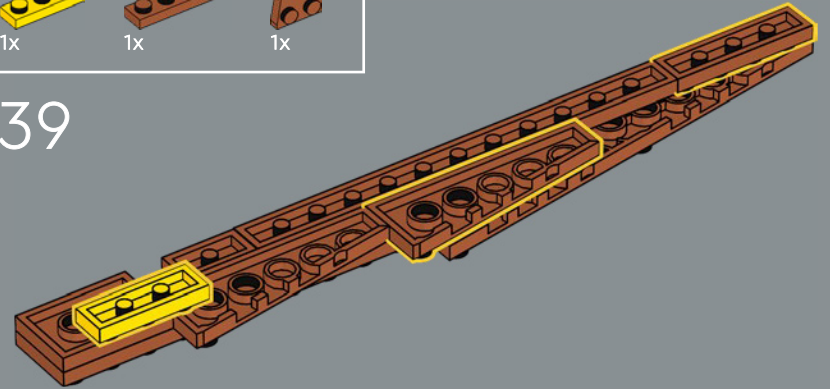

240

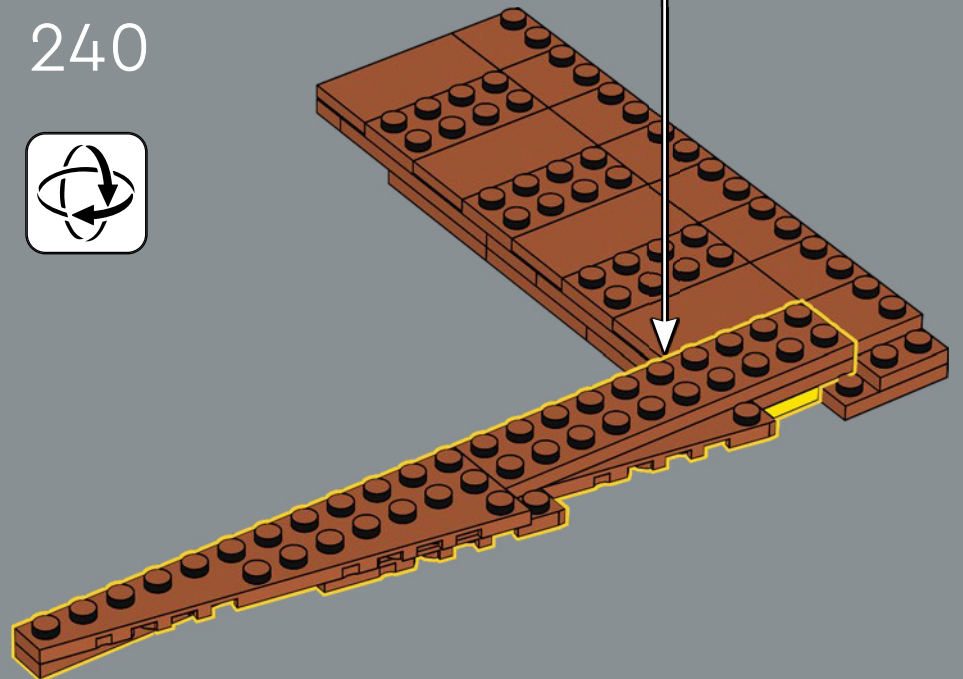

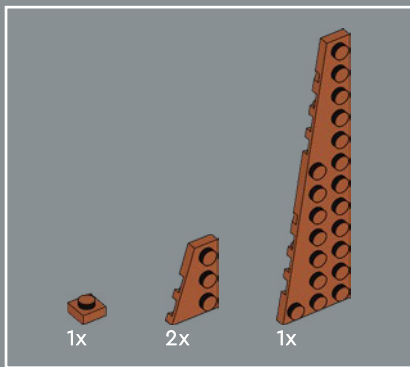

241

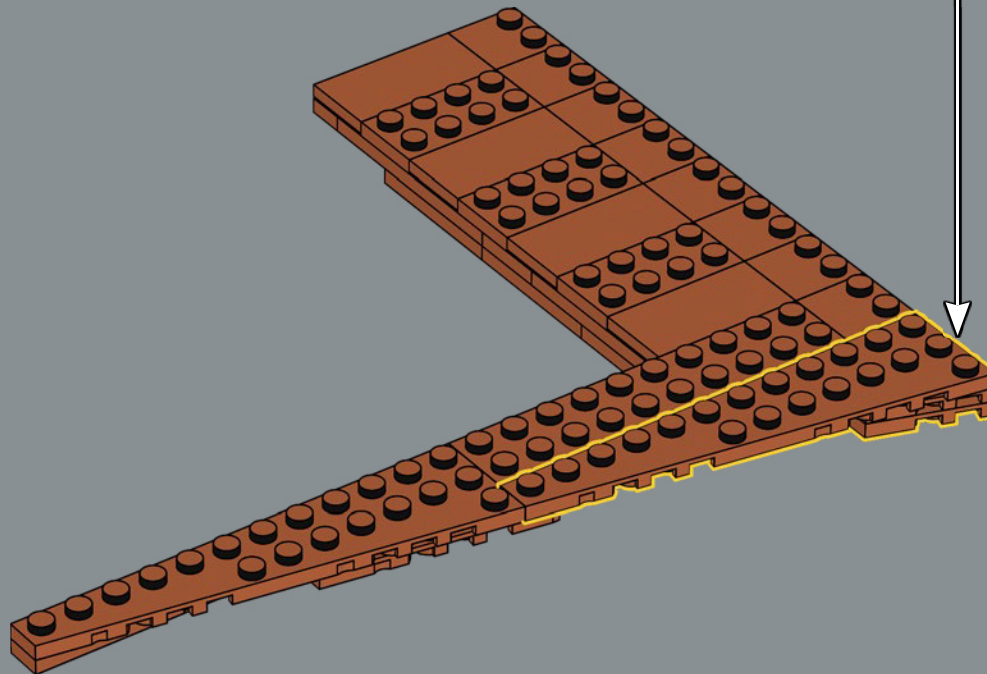
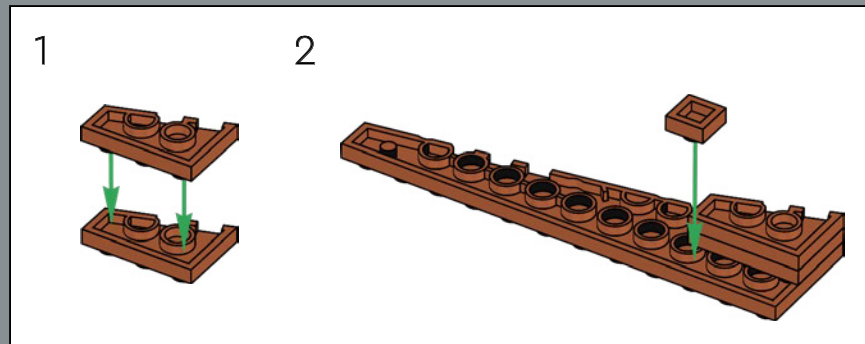

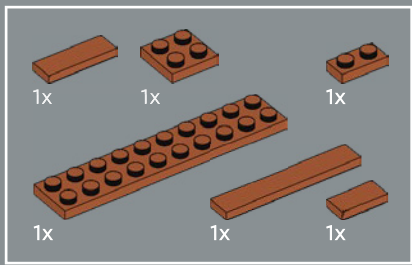

242

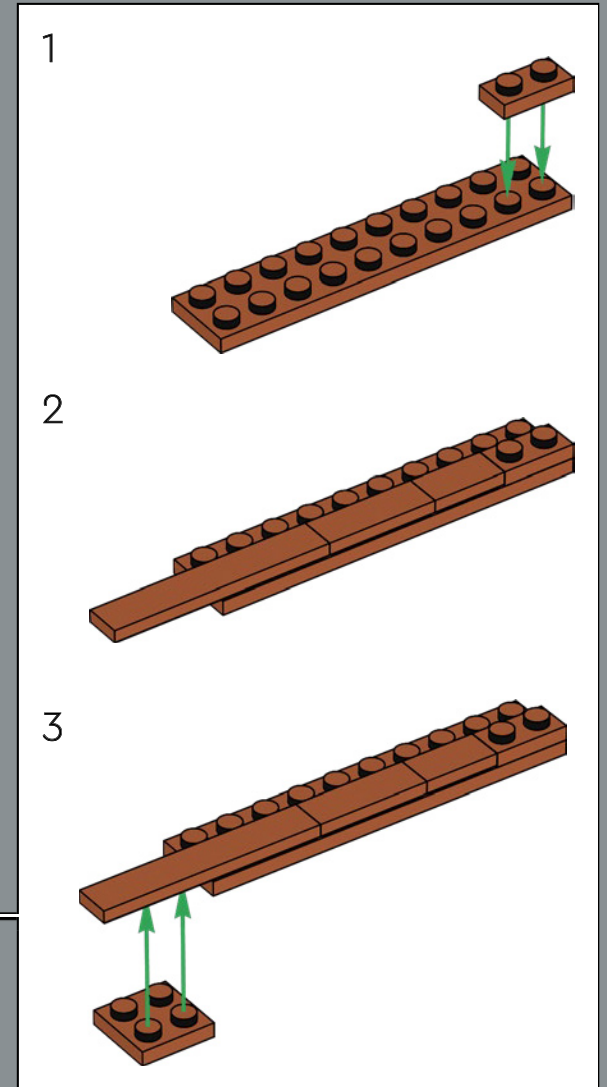
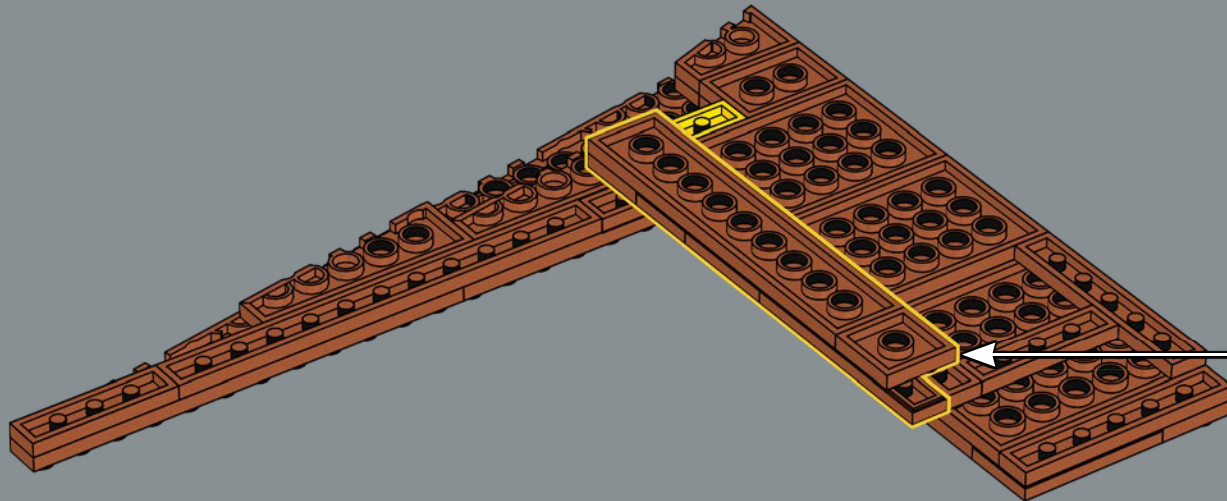

243



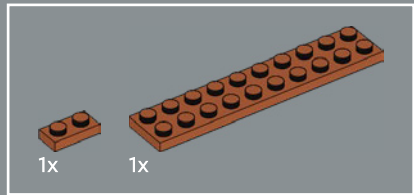
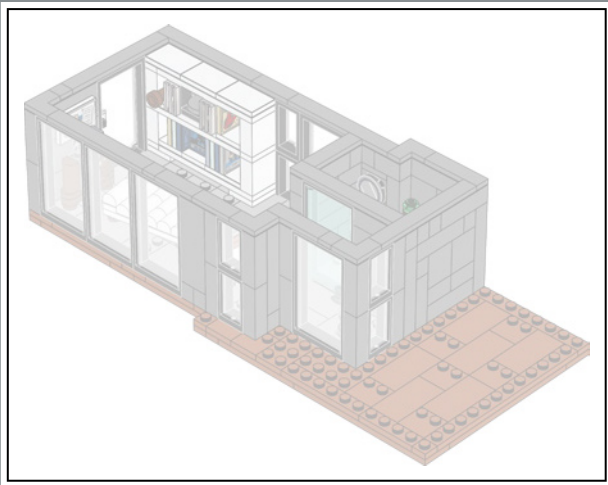

244

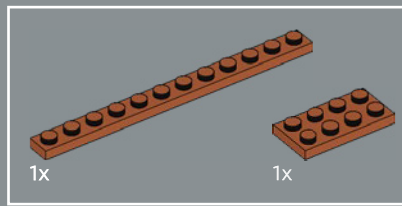
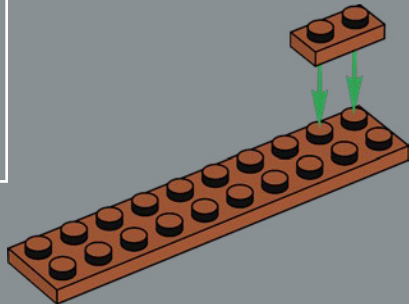

245

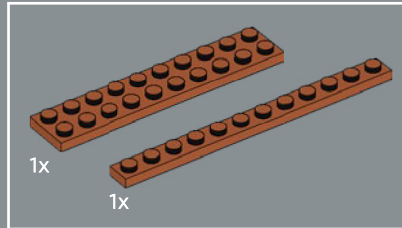
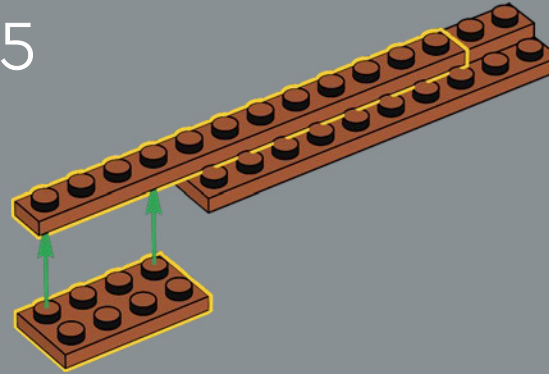

246

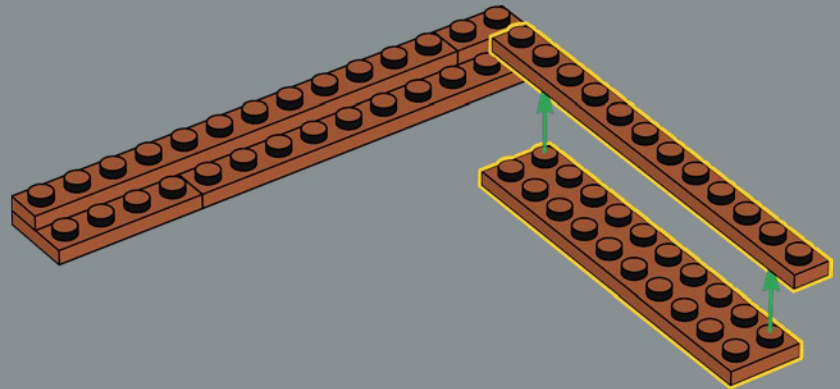

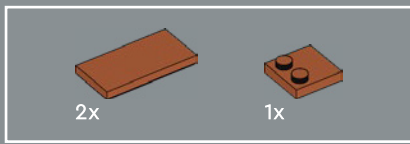

247

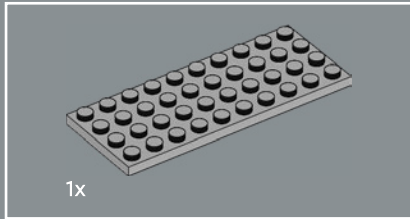
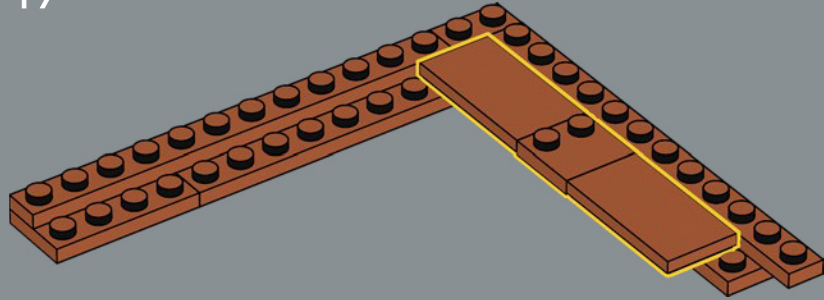

248

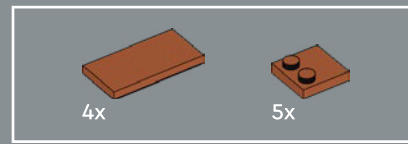
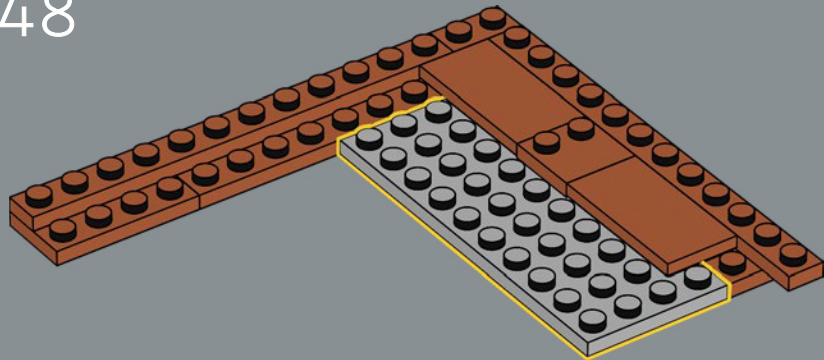

249

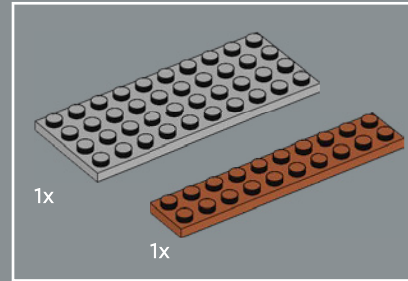
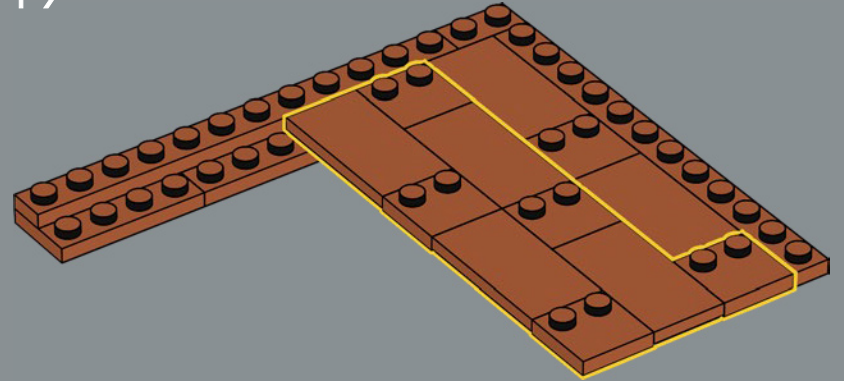

250

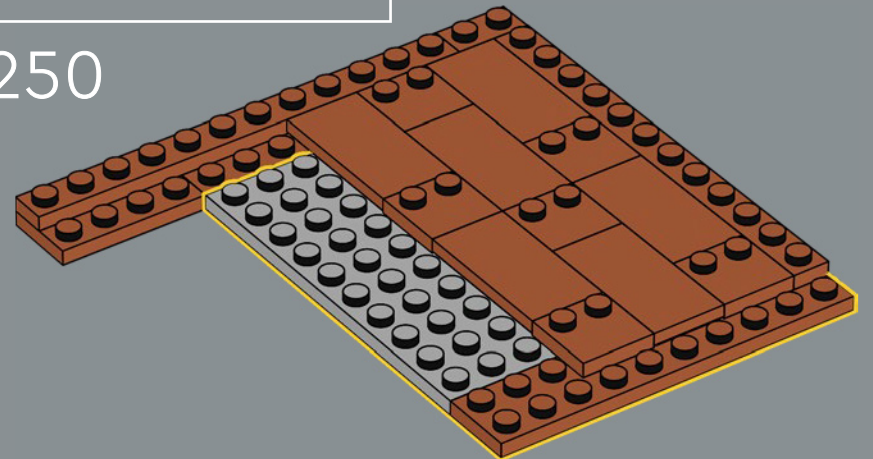

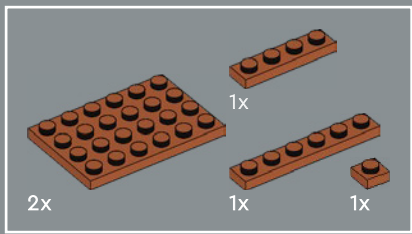

251

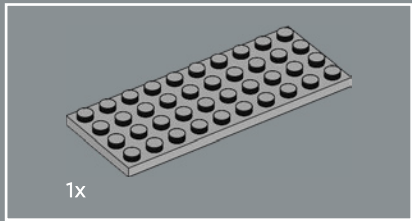
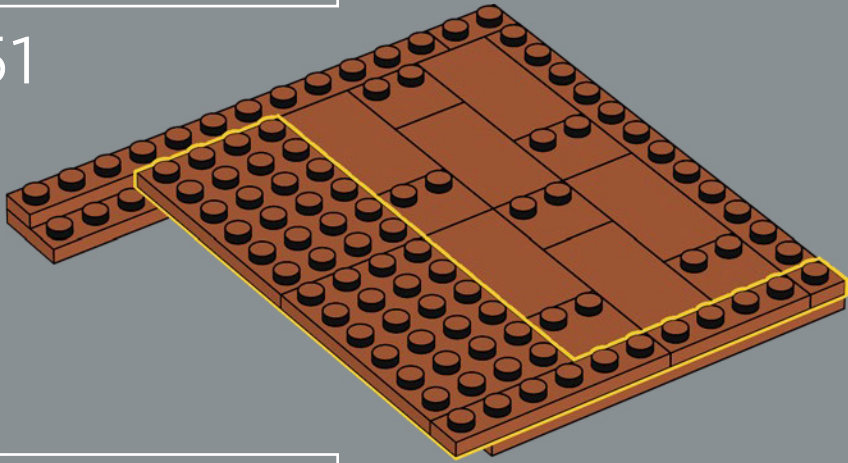

252

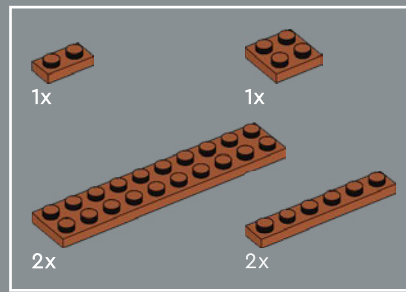
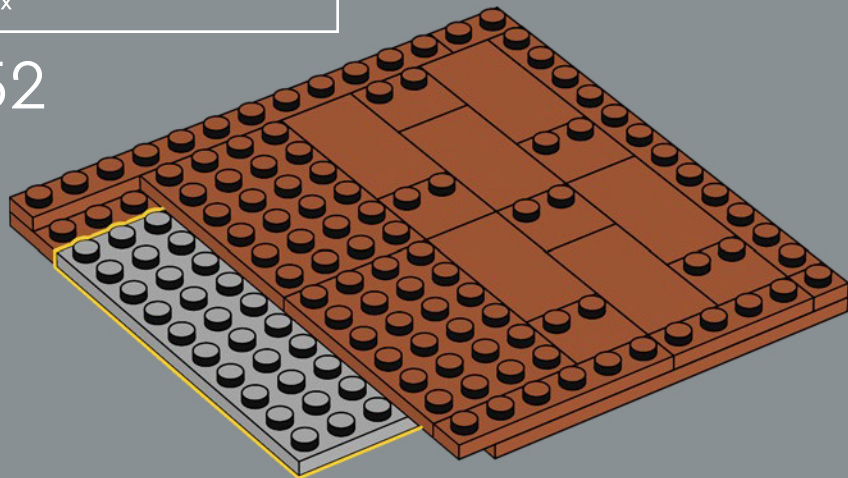

253

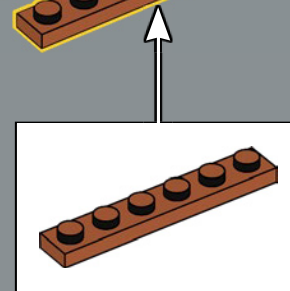
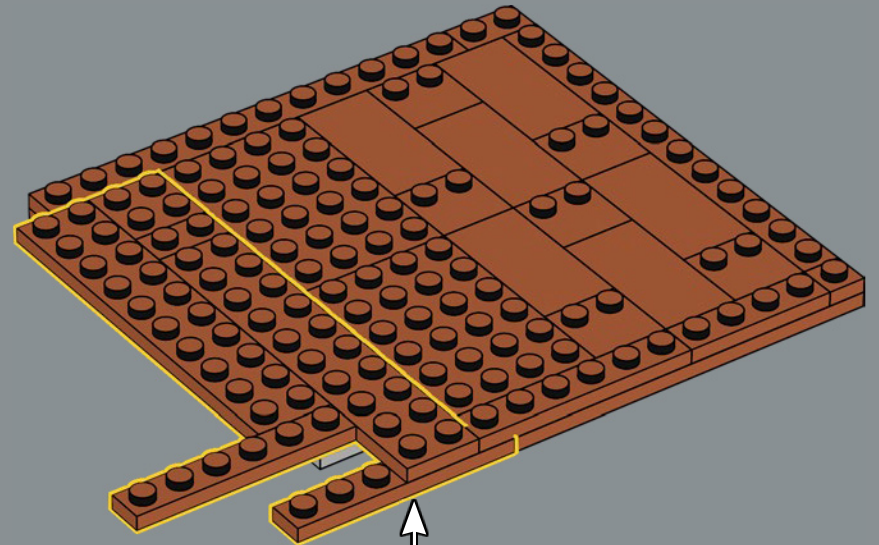

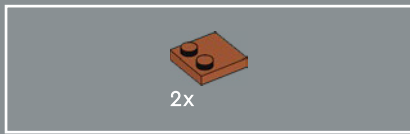

254

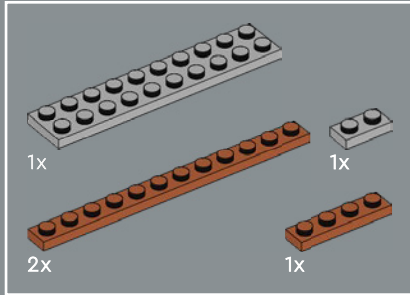
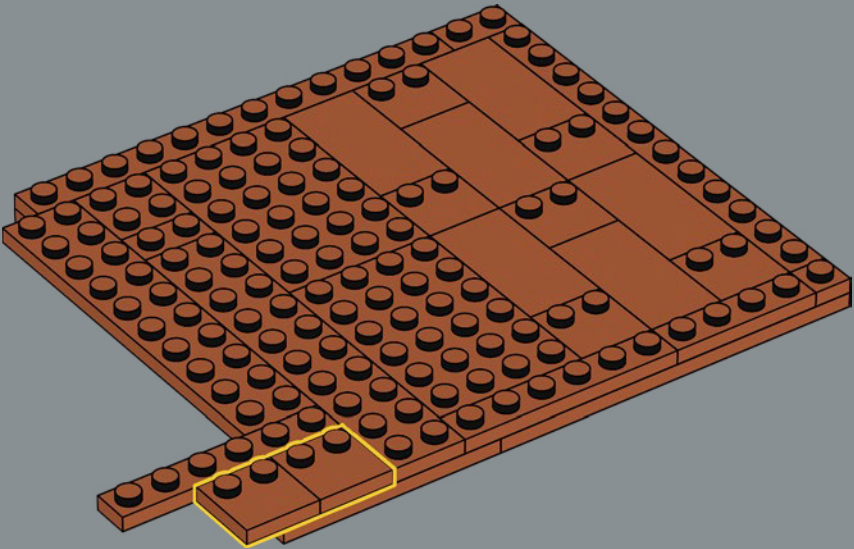

255

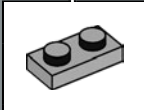
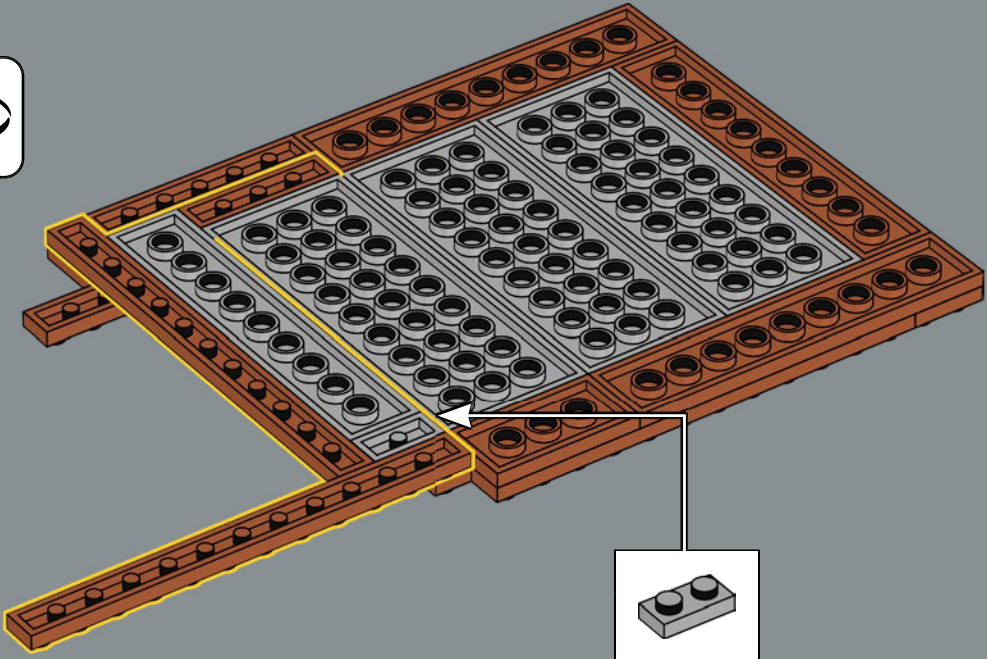

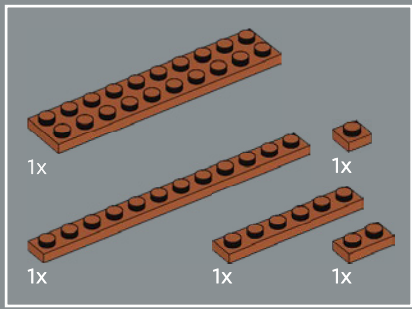

256

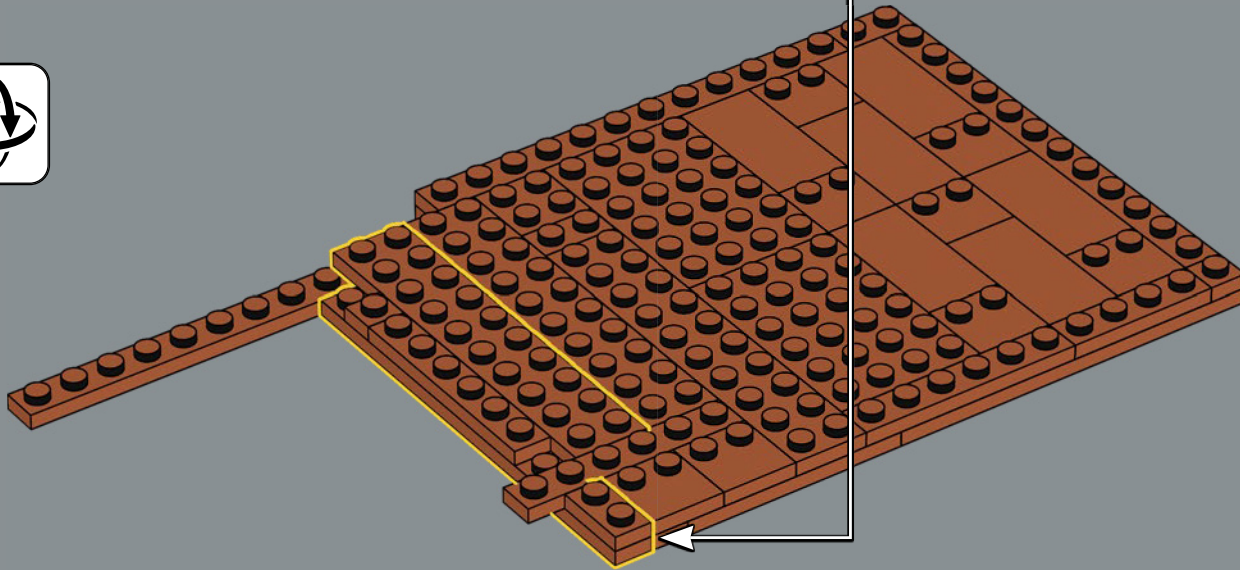
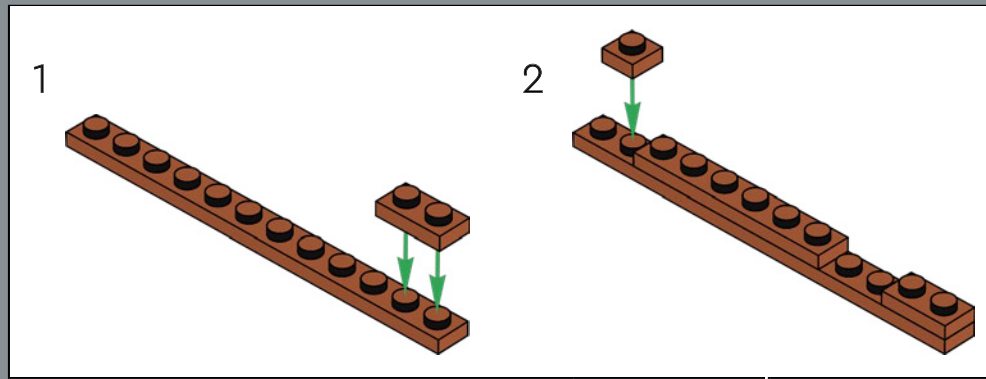

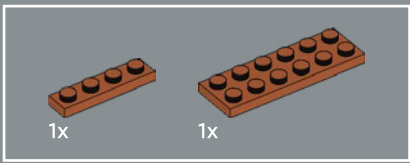

257

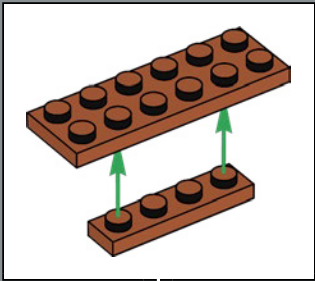

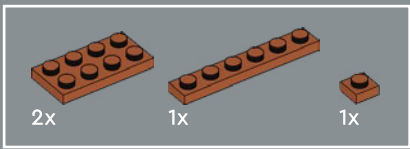

258

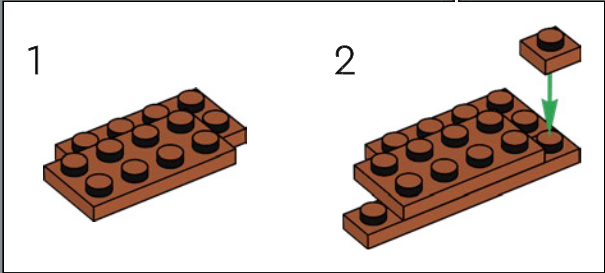
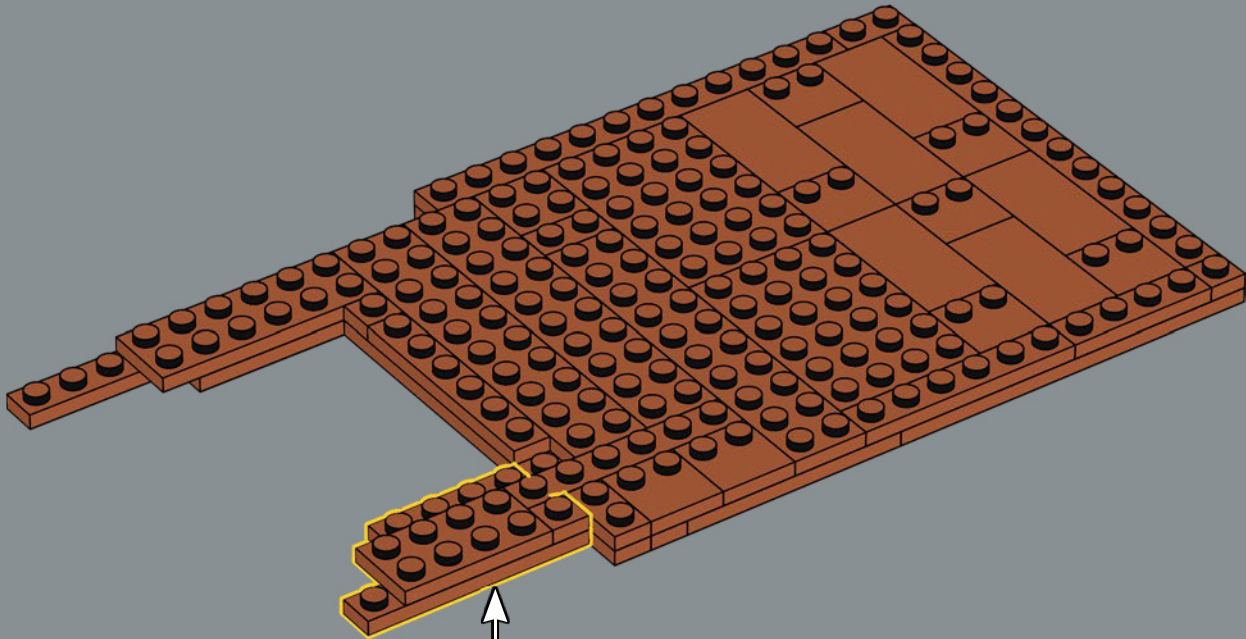

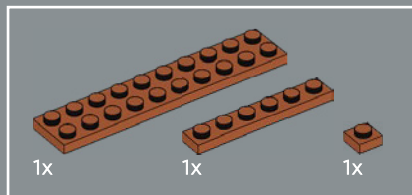

259

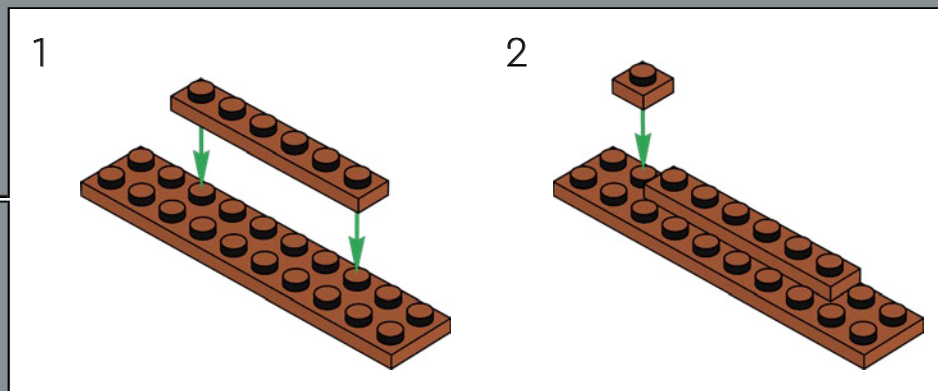
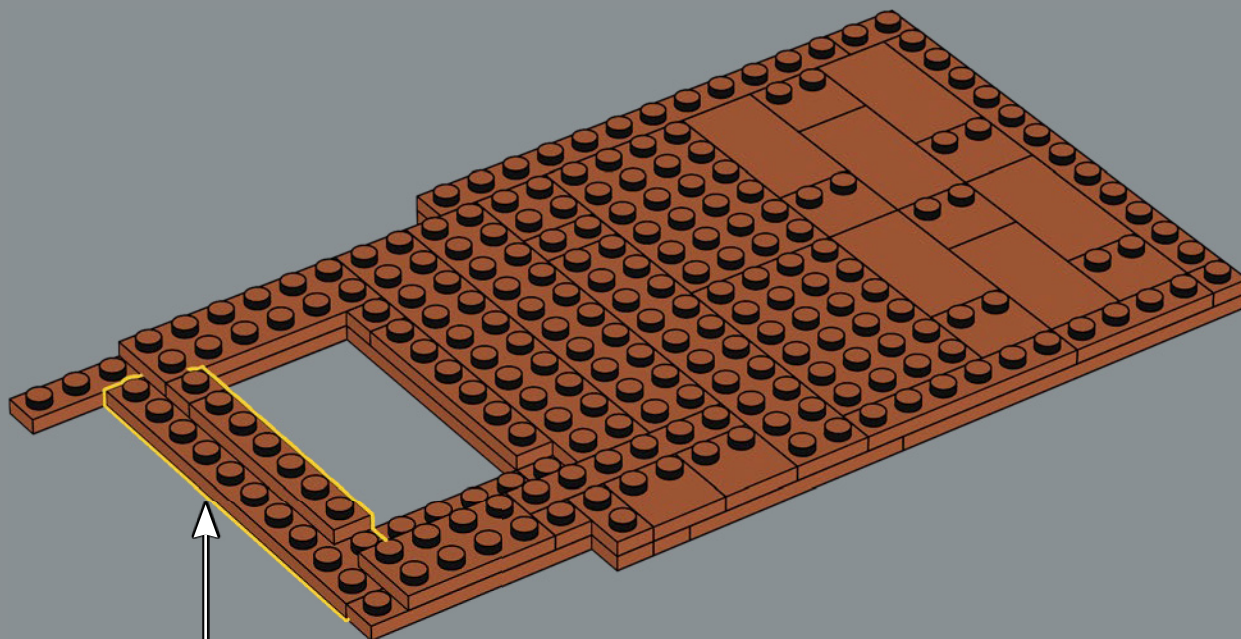

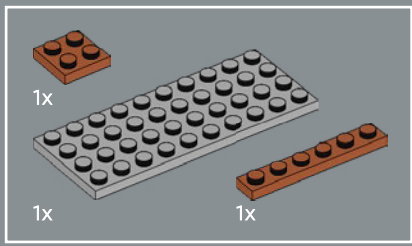

260

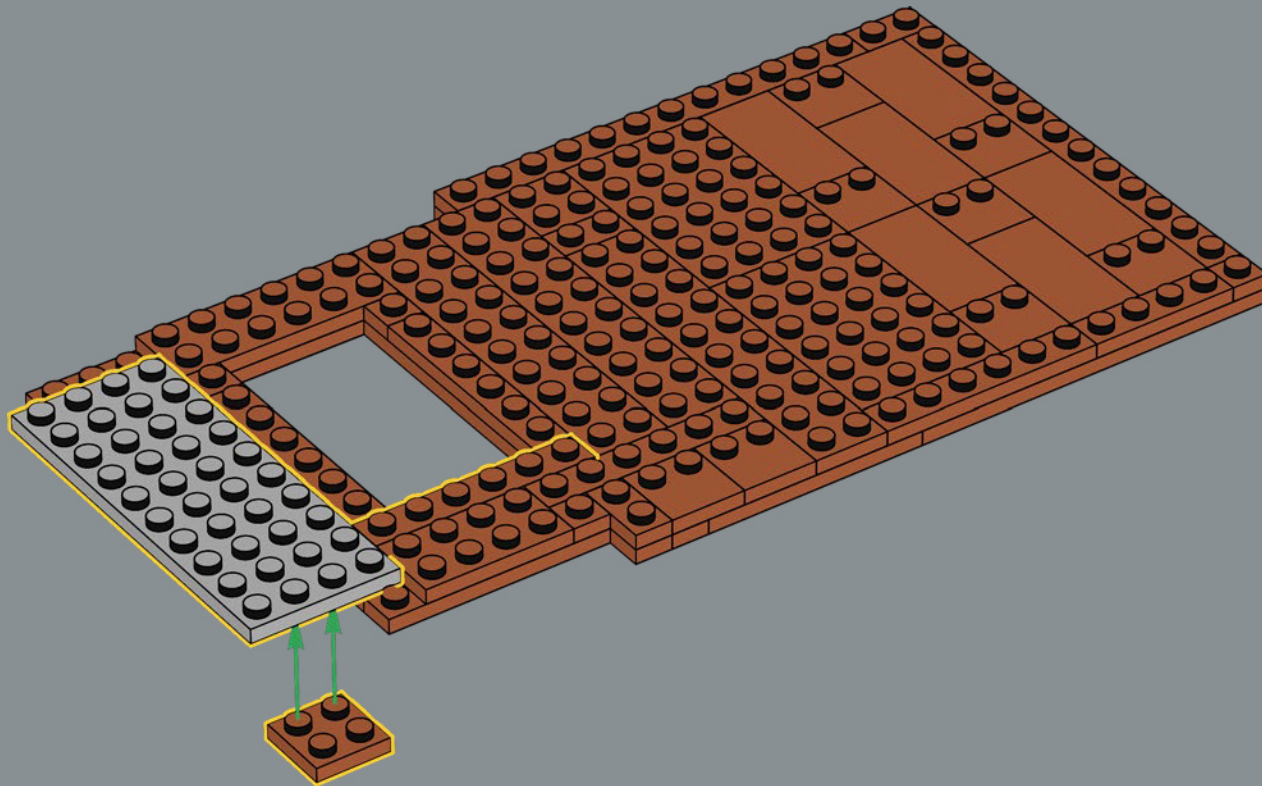

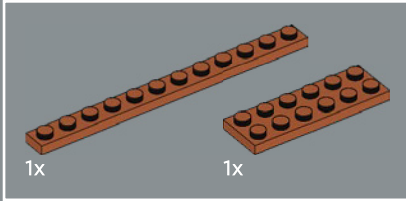
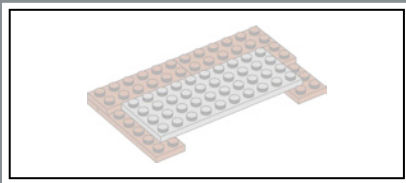

261

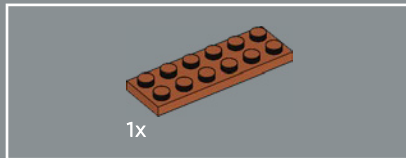
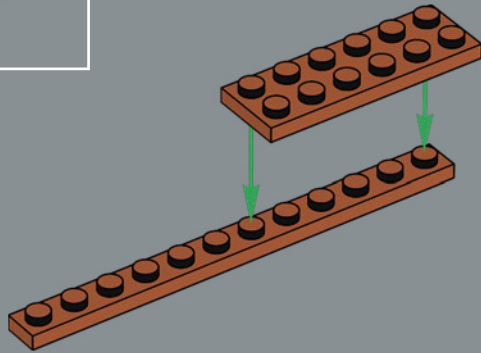

262

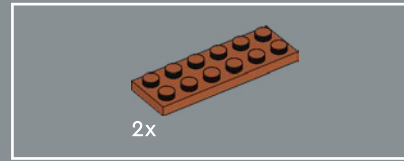
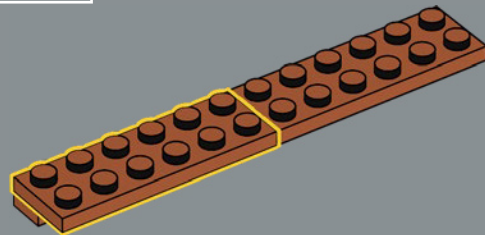

263

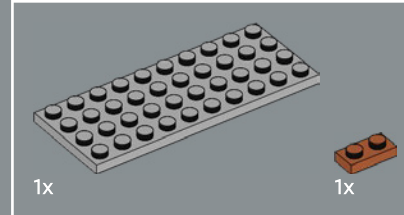
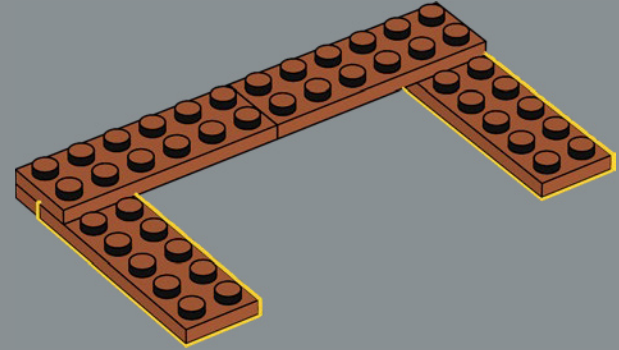

264

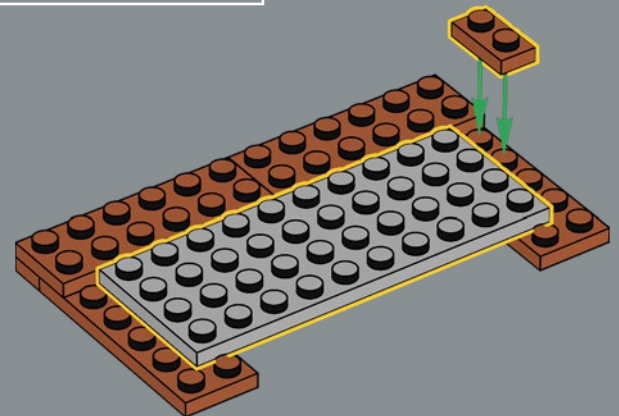

265

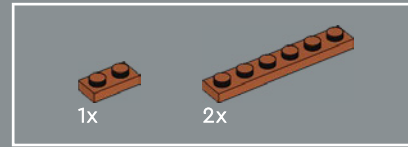
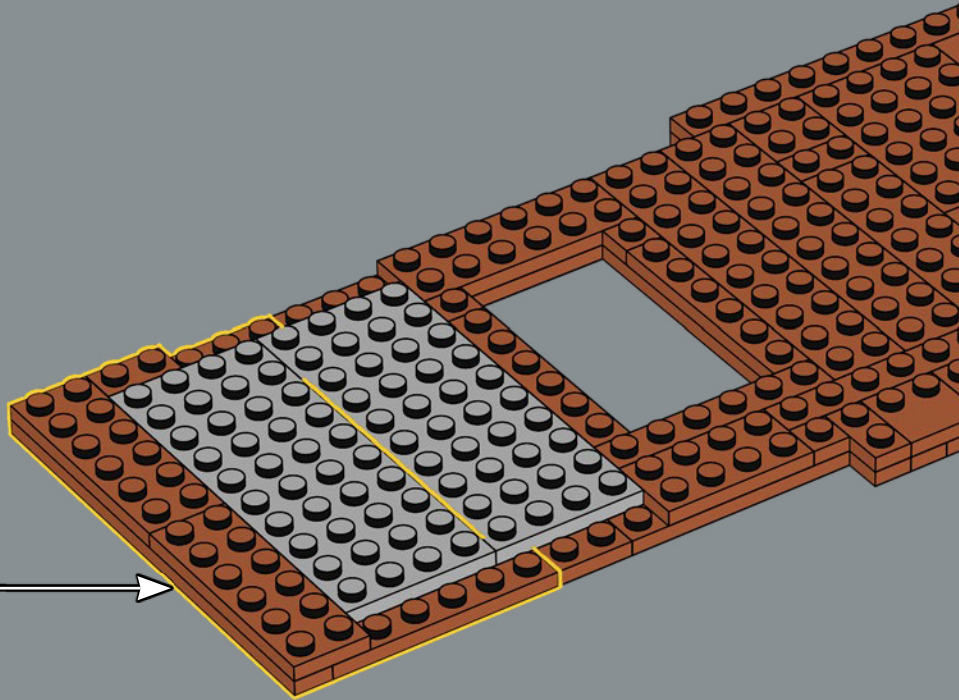

266

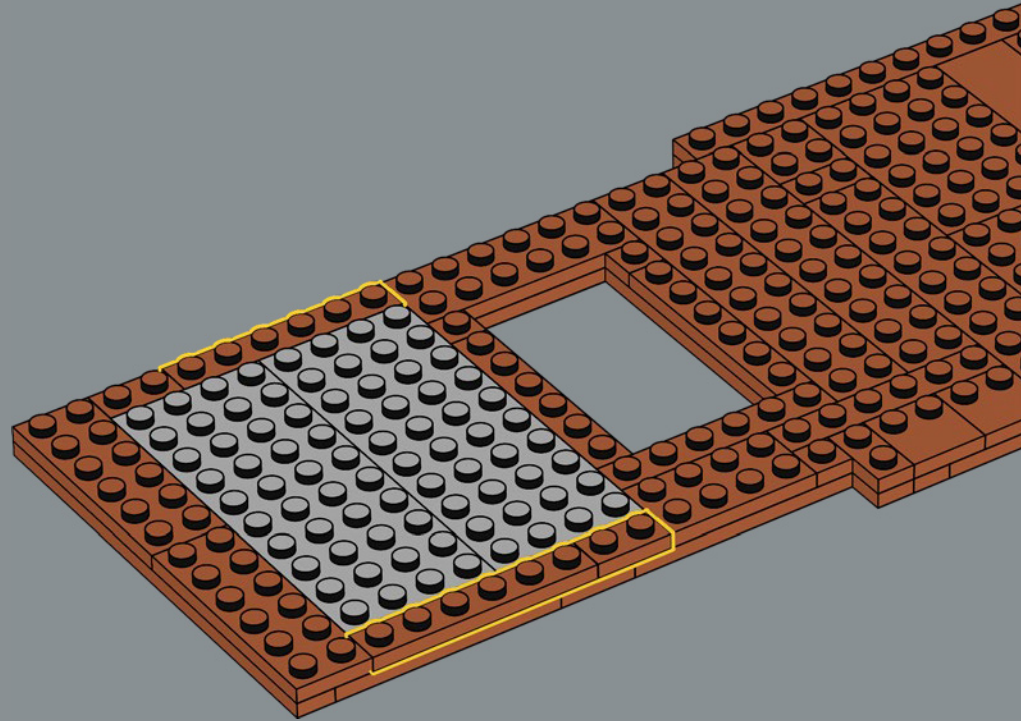

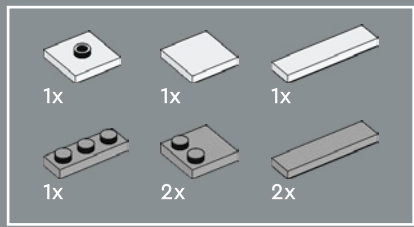

269

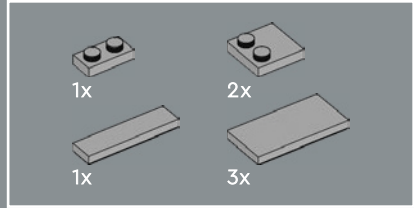
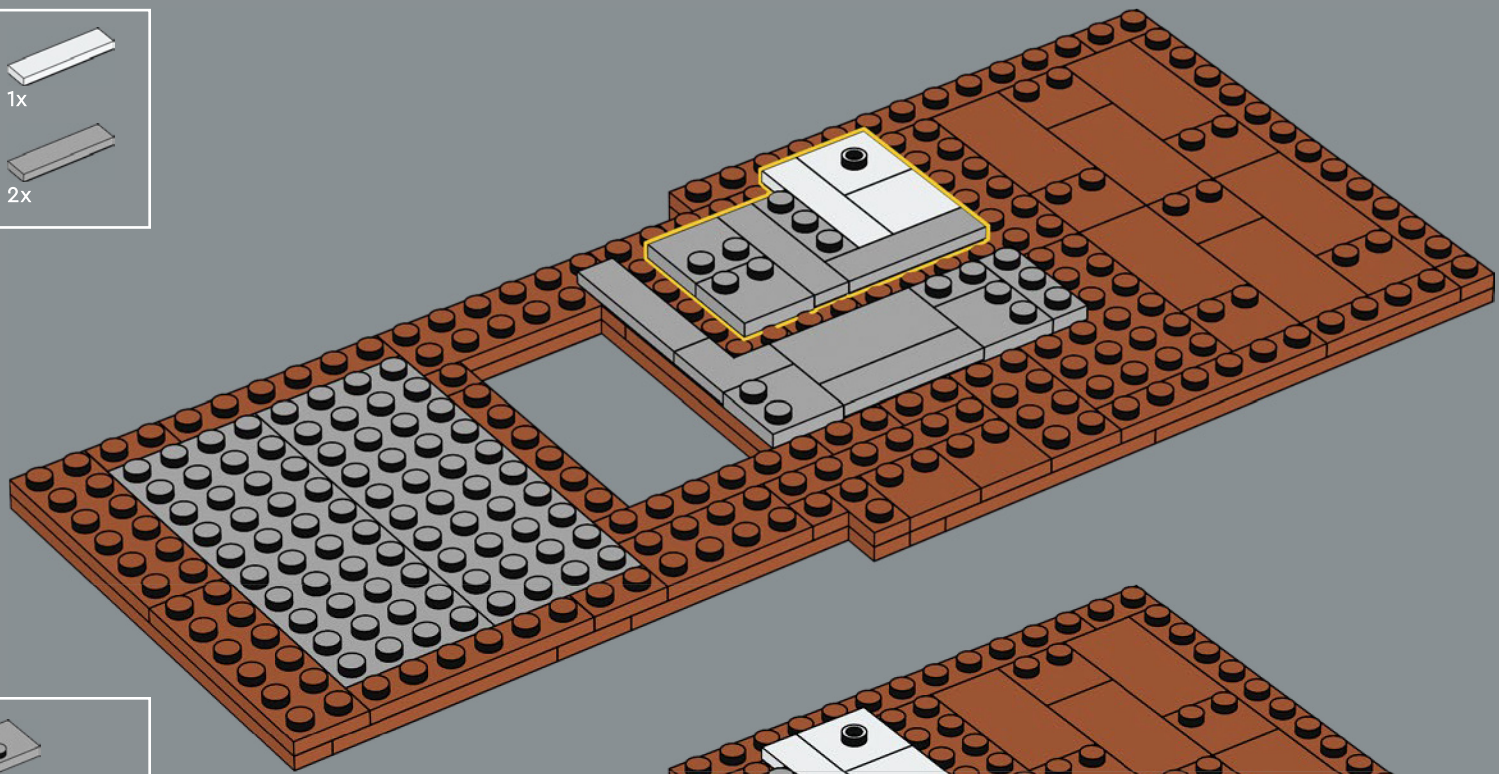

270

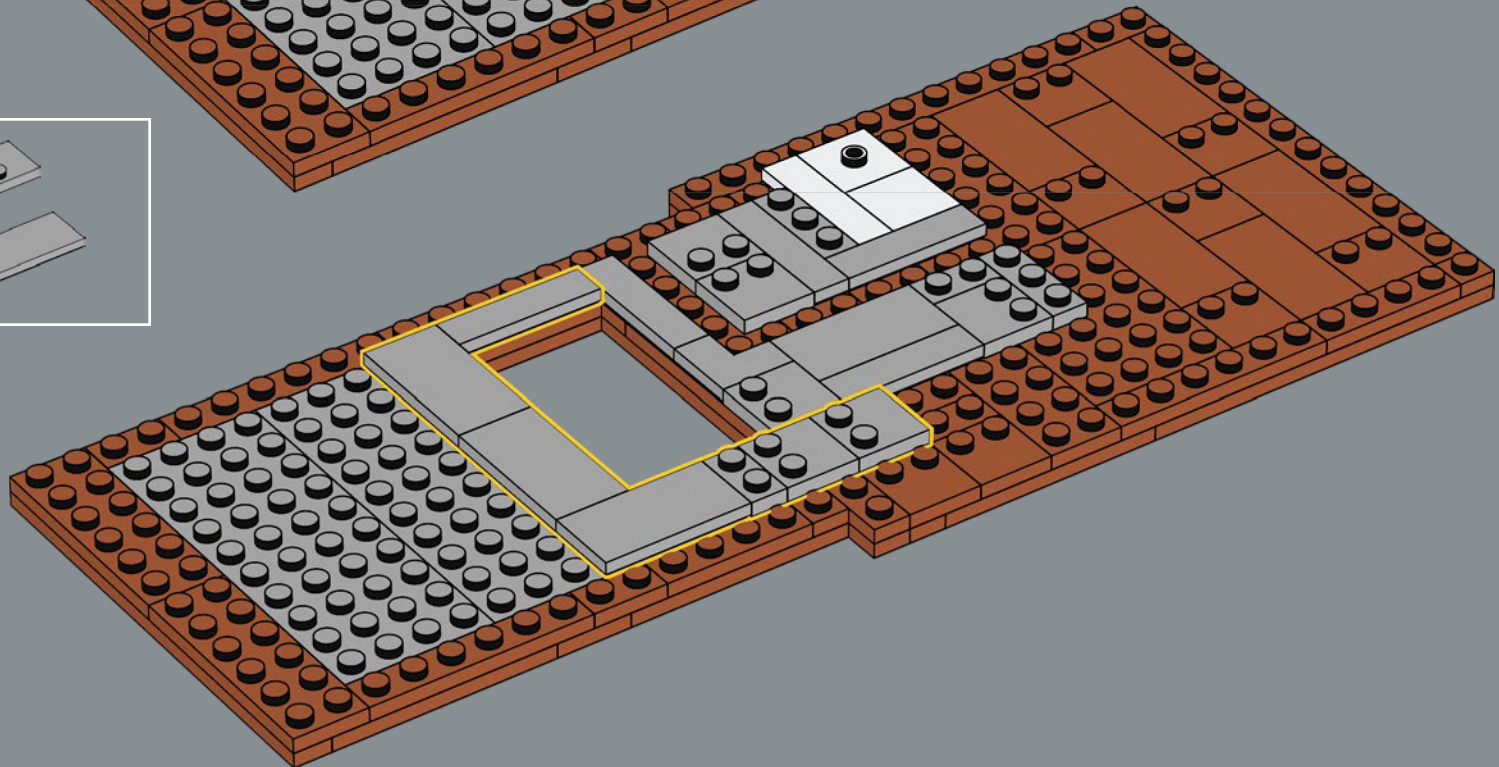

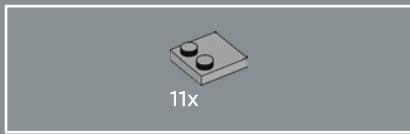

271

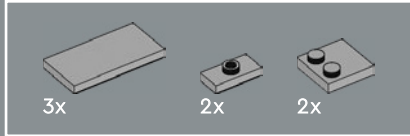
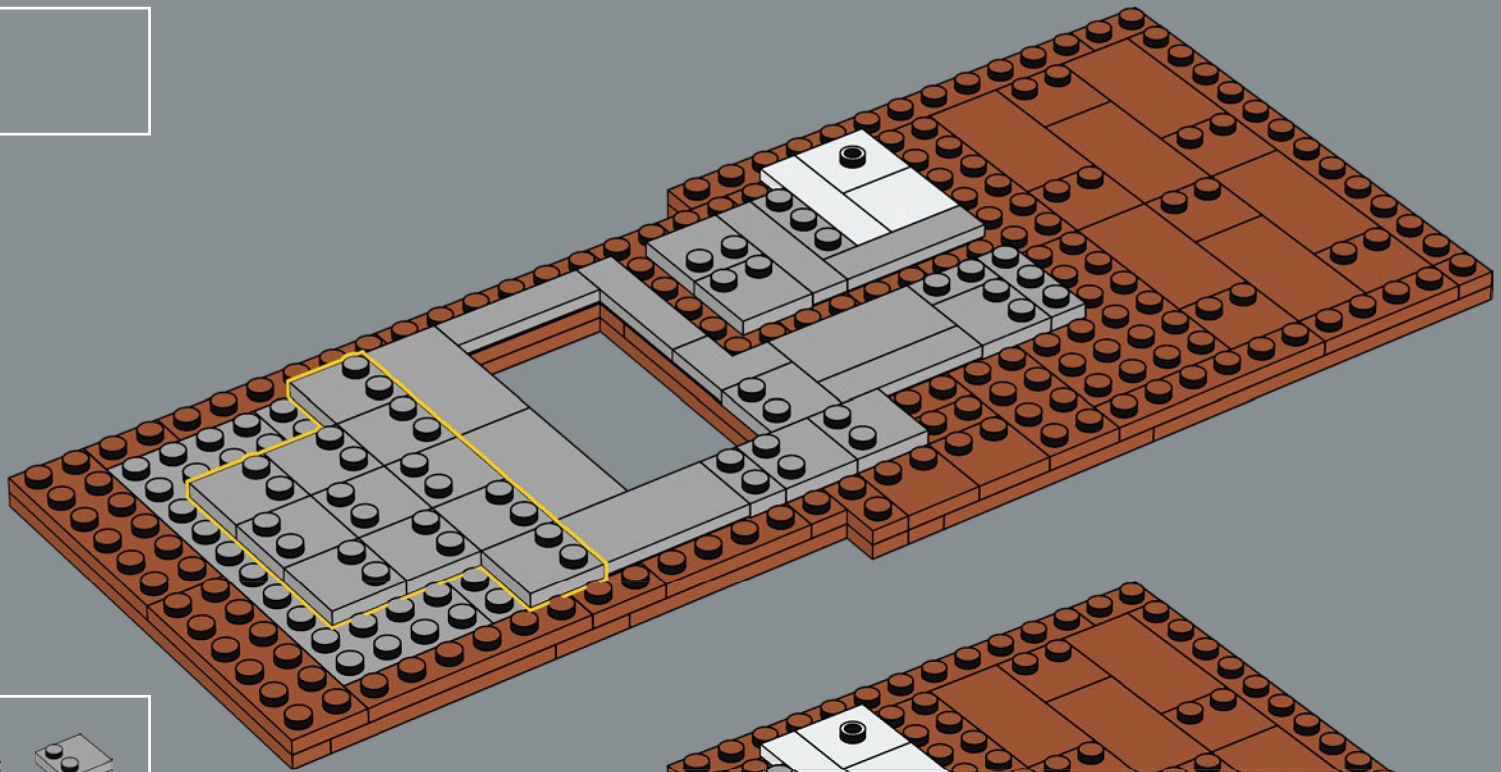

272

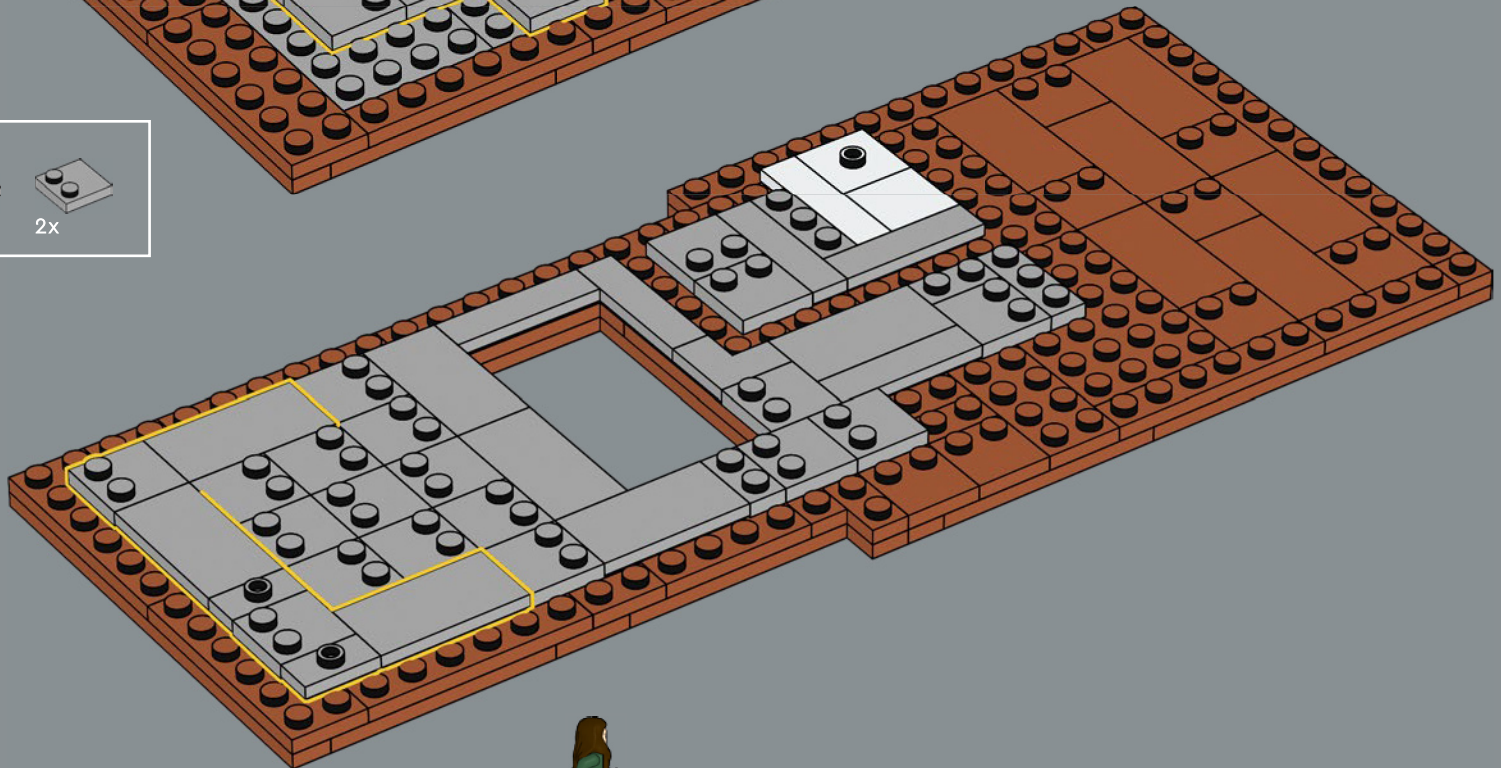

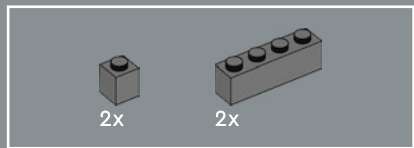

273

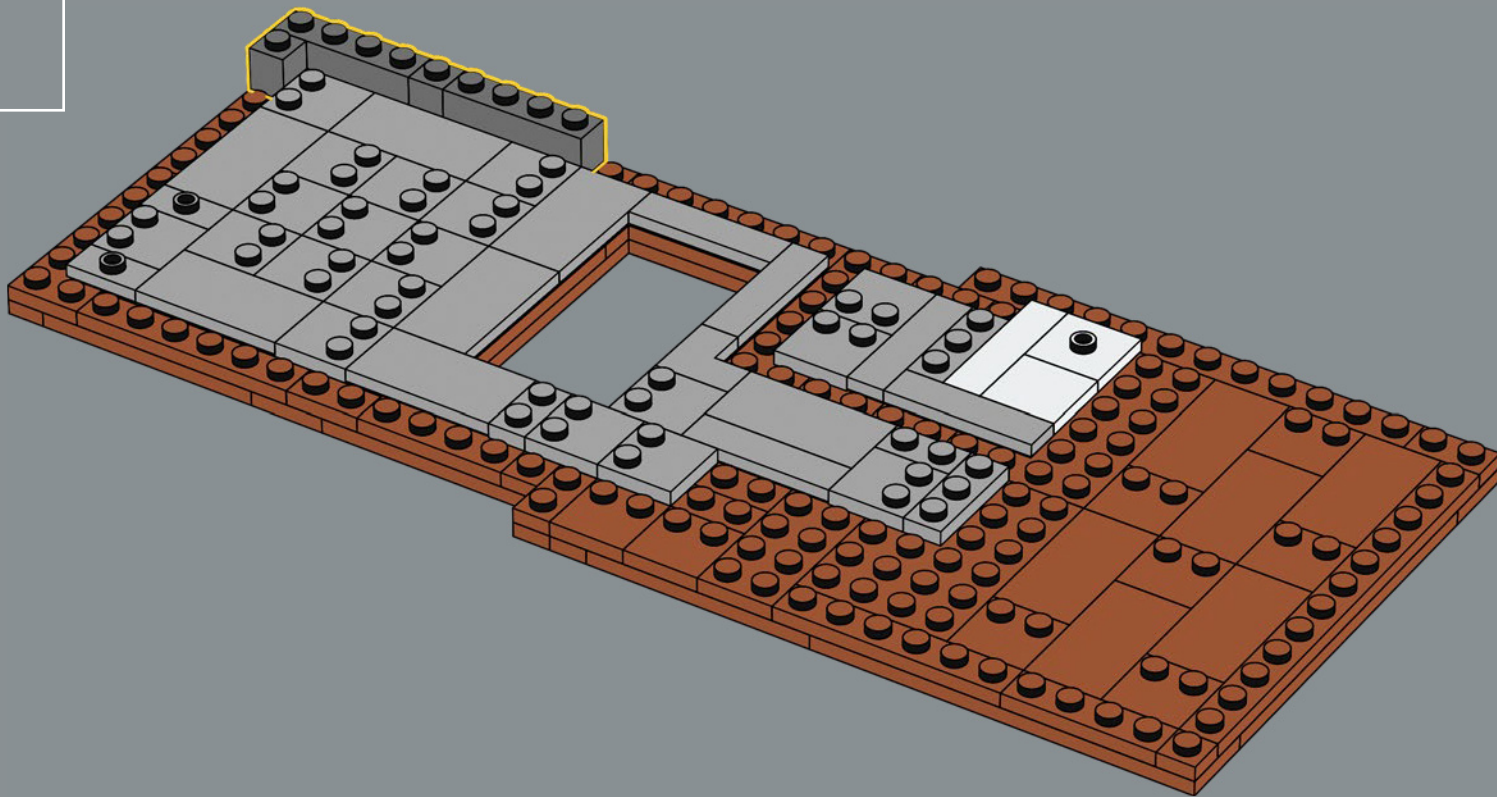

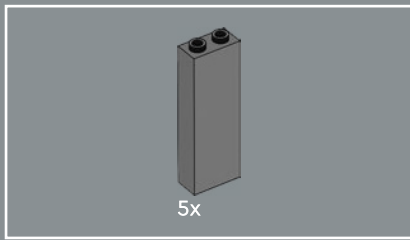

274

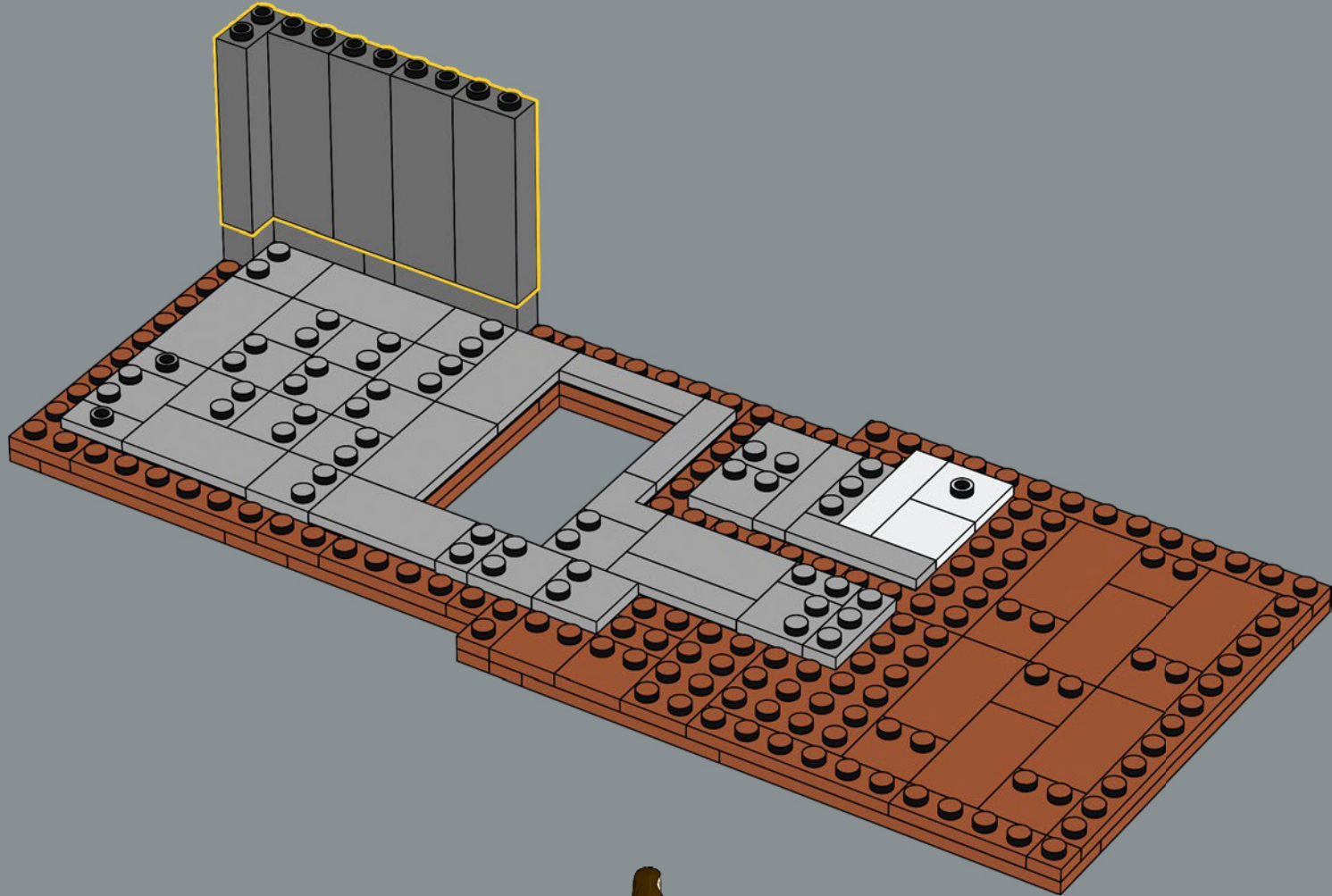

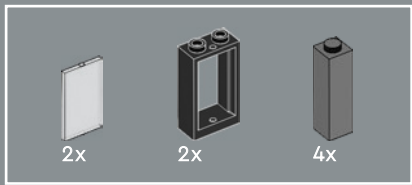

275

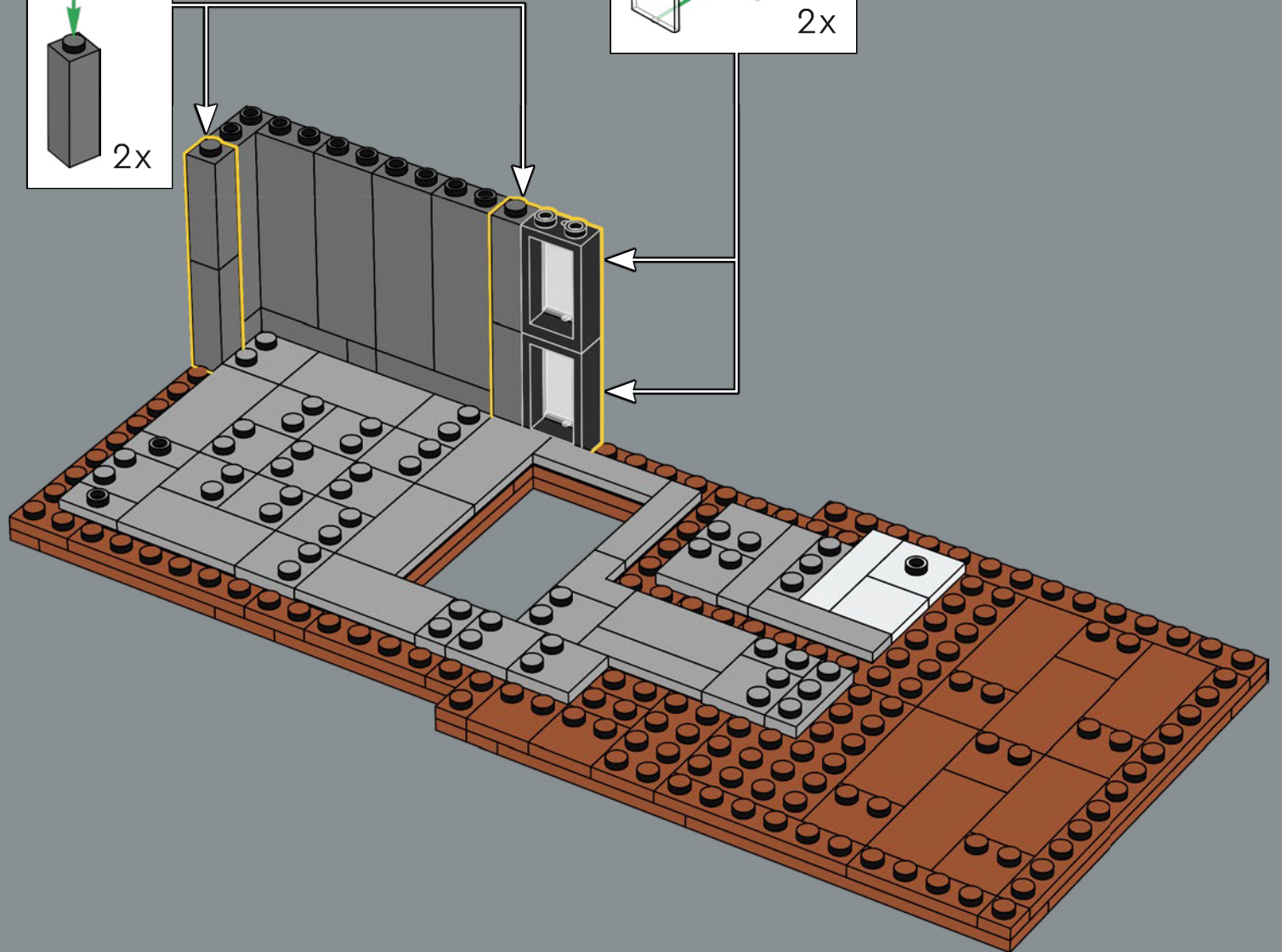
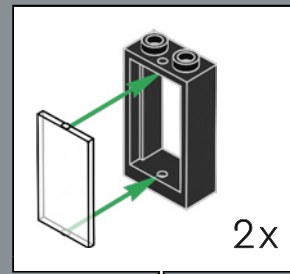
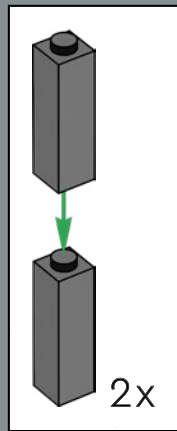

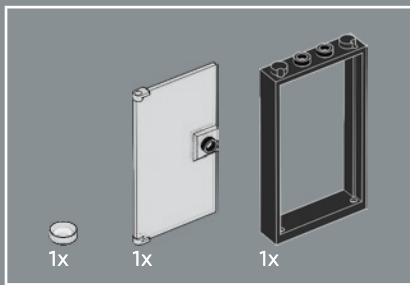

276

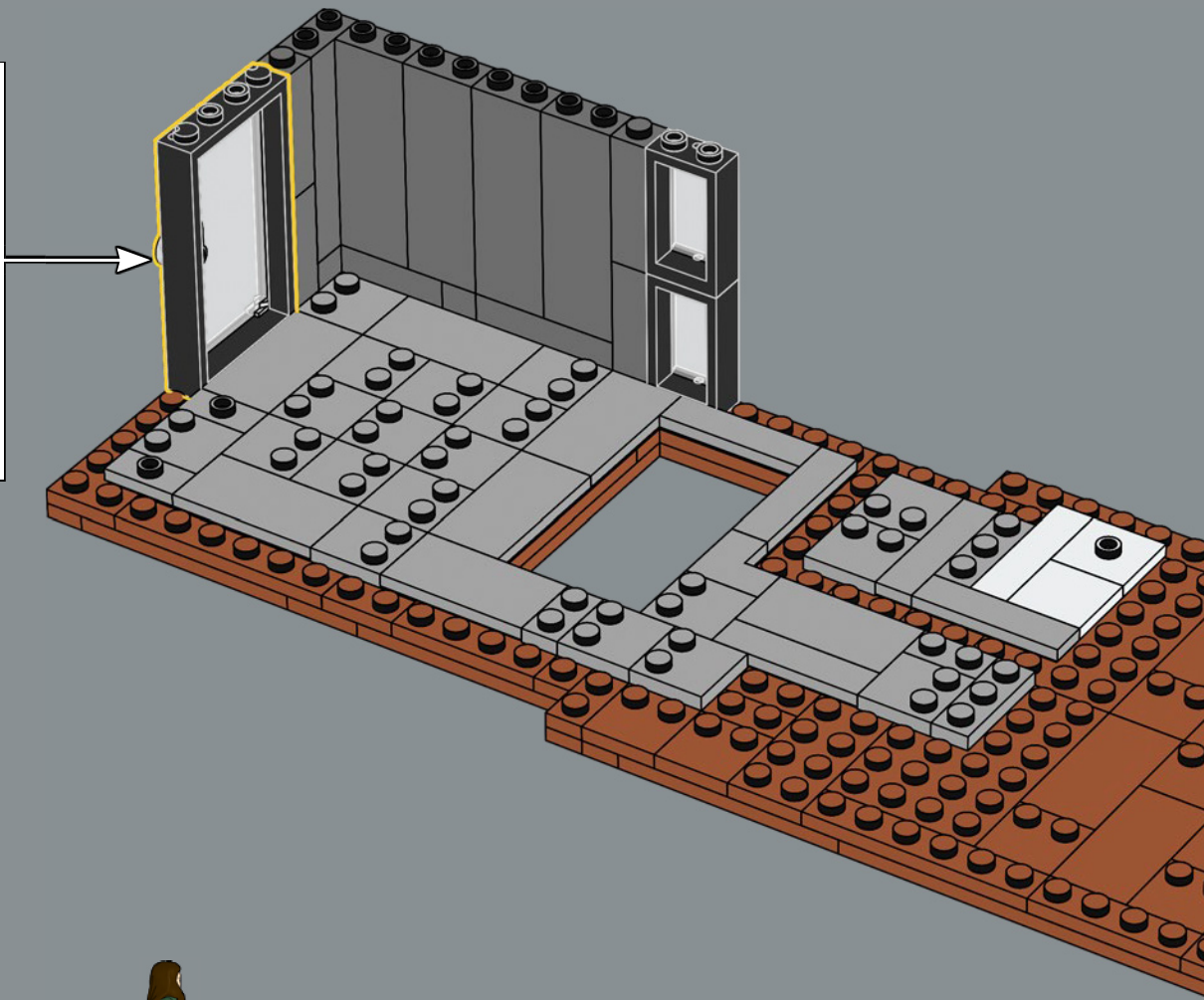
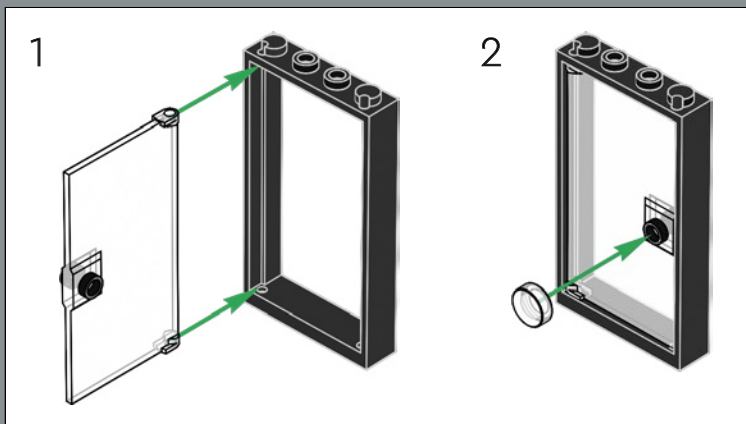

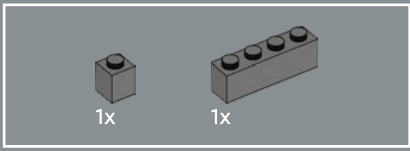

277

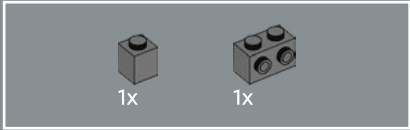
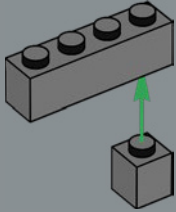

278

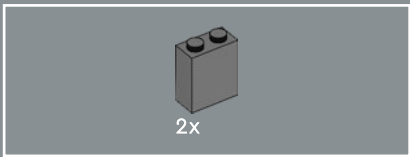
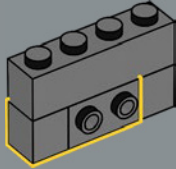

279

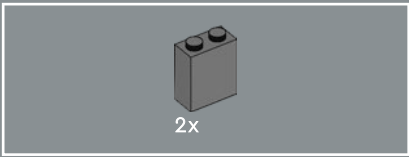
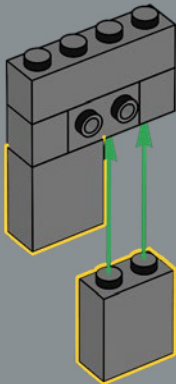

280

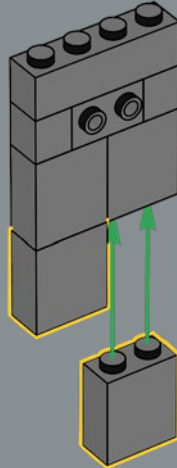

281

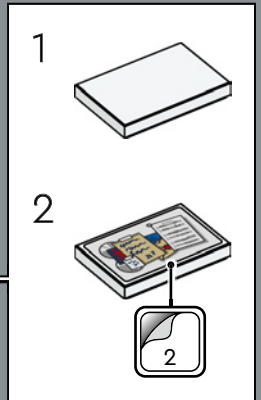

282

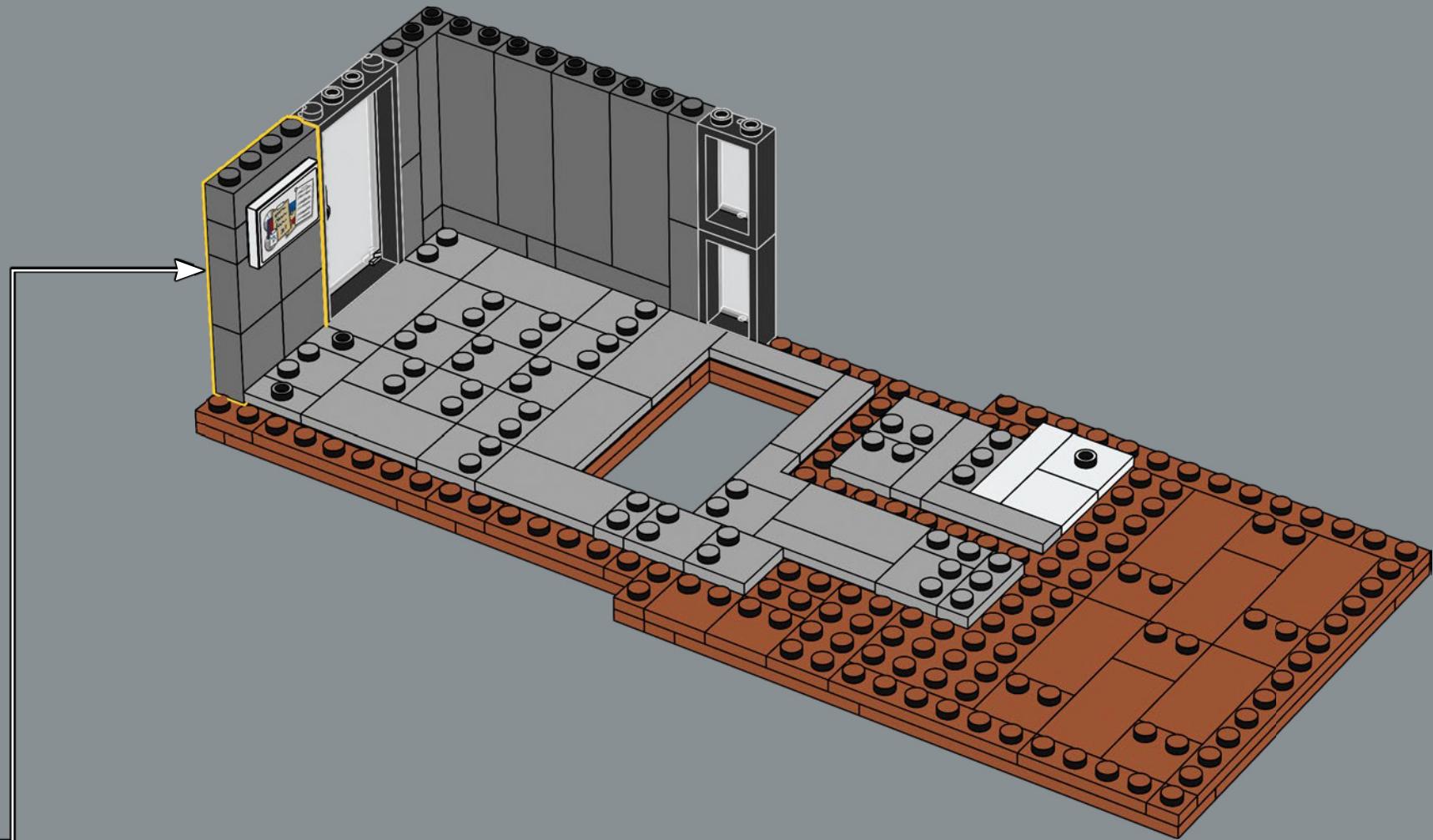

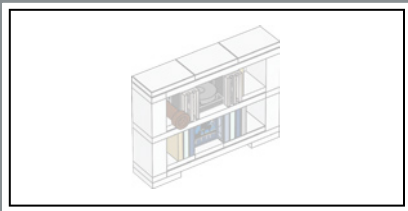

283

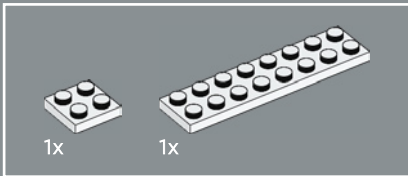
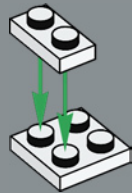

284

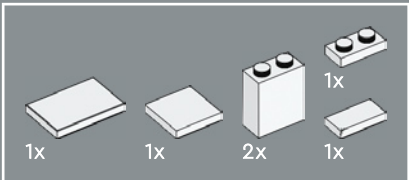
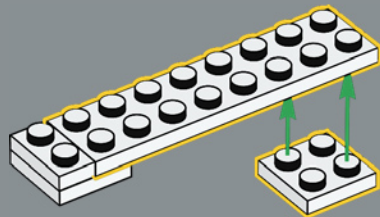

285

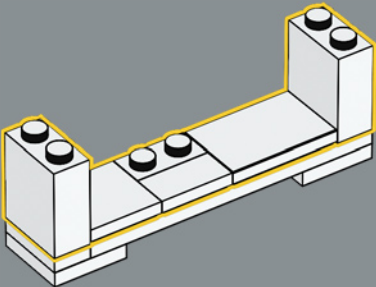

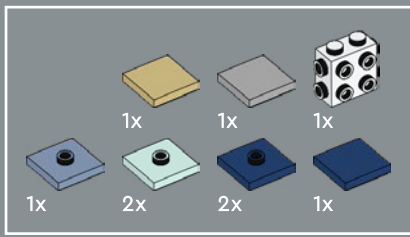

286

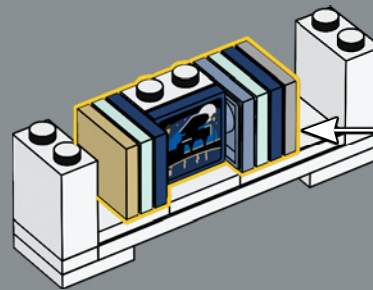
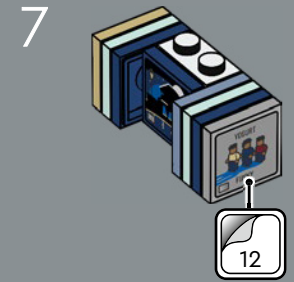
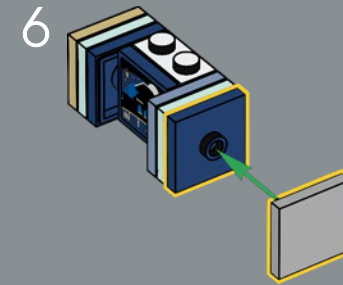
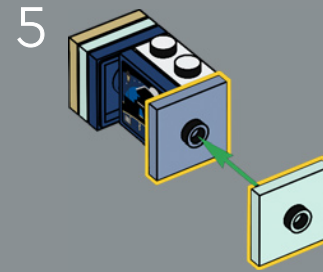
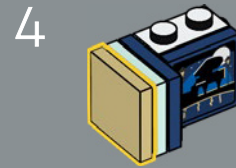
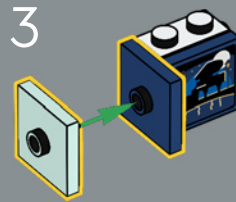
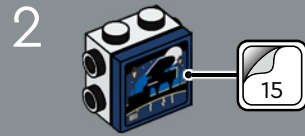
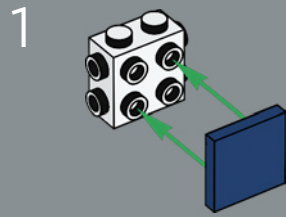

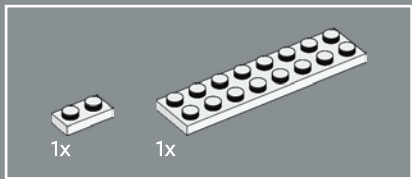

287

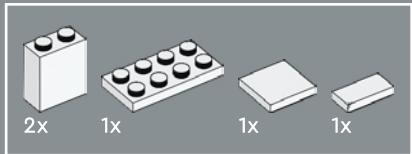
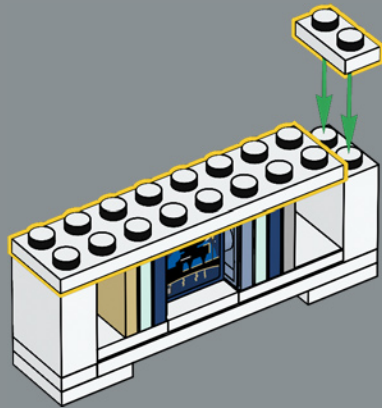

288

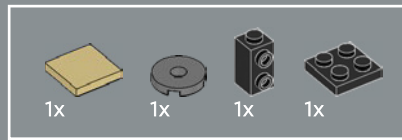
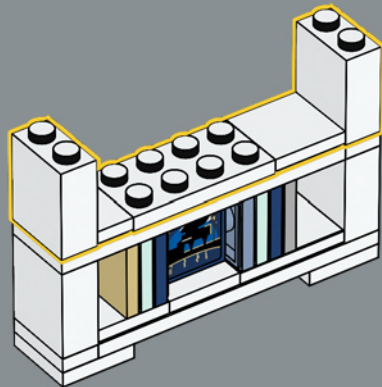

289

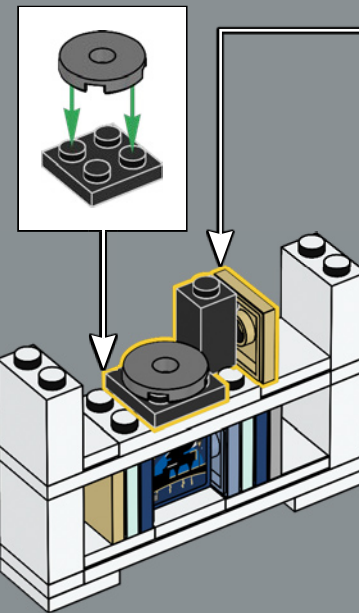
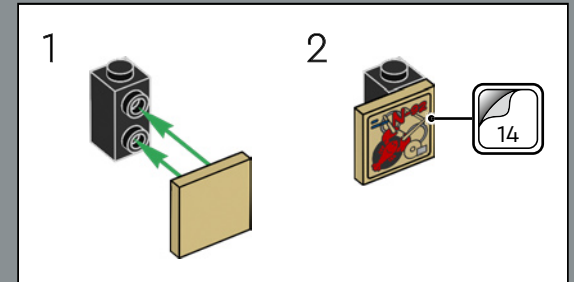



290

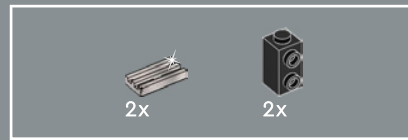
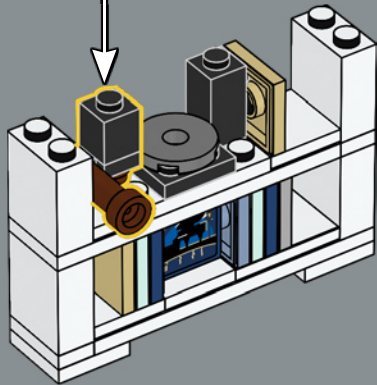
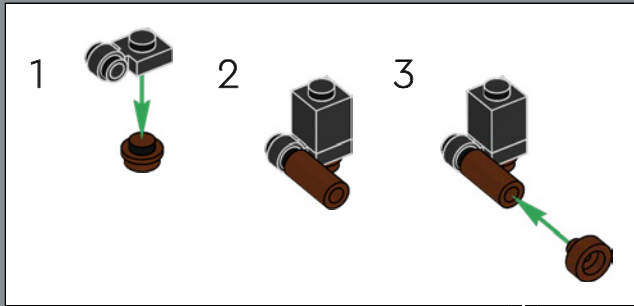

291

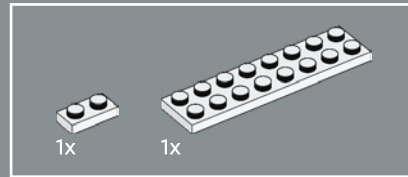
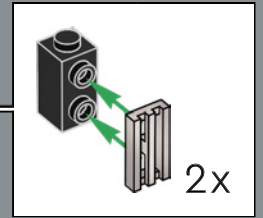
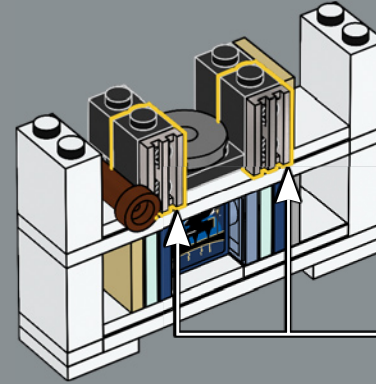

292

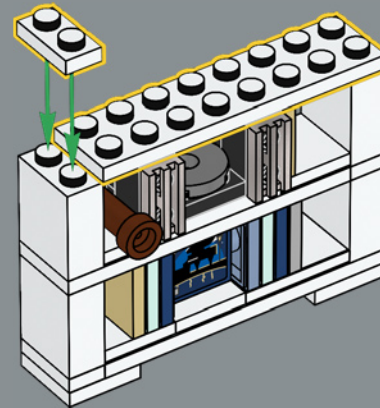



293

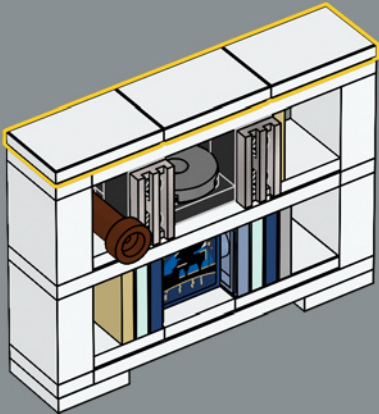

294

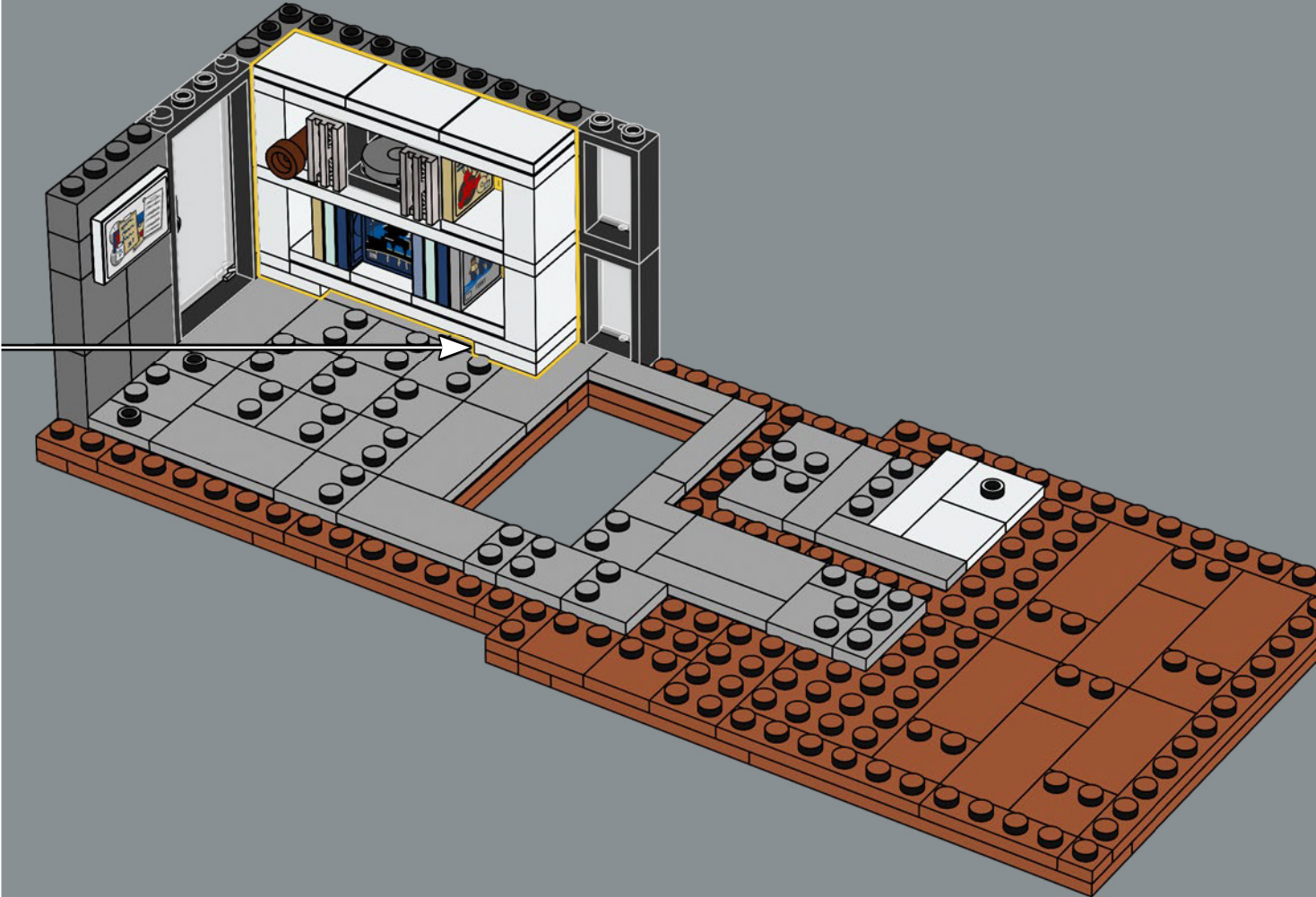

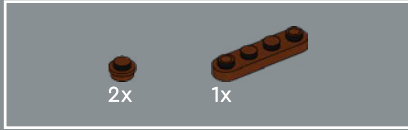

295

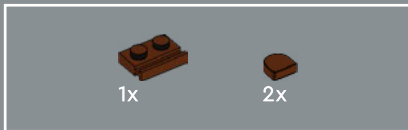
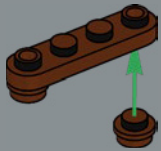

296

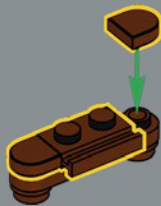

297

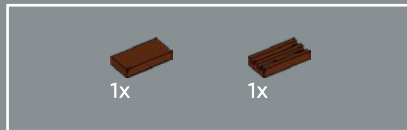

298

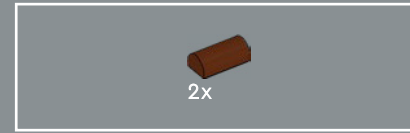
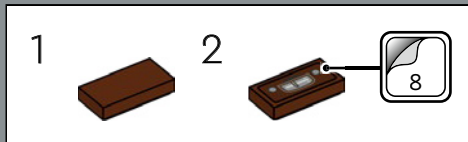

299

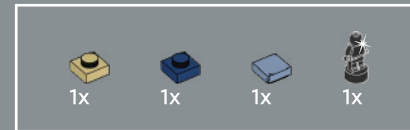
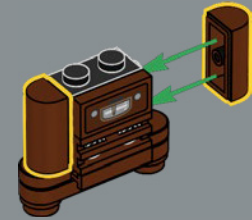

300

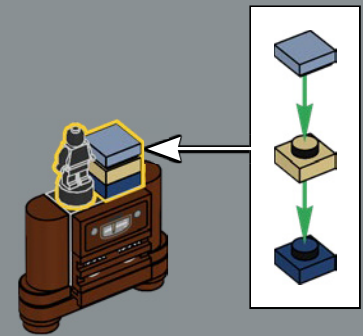

301

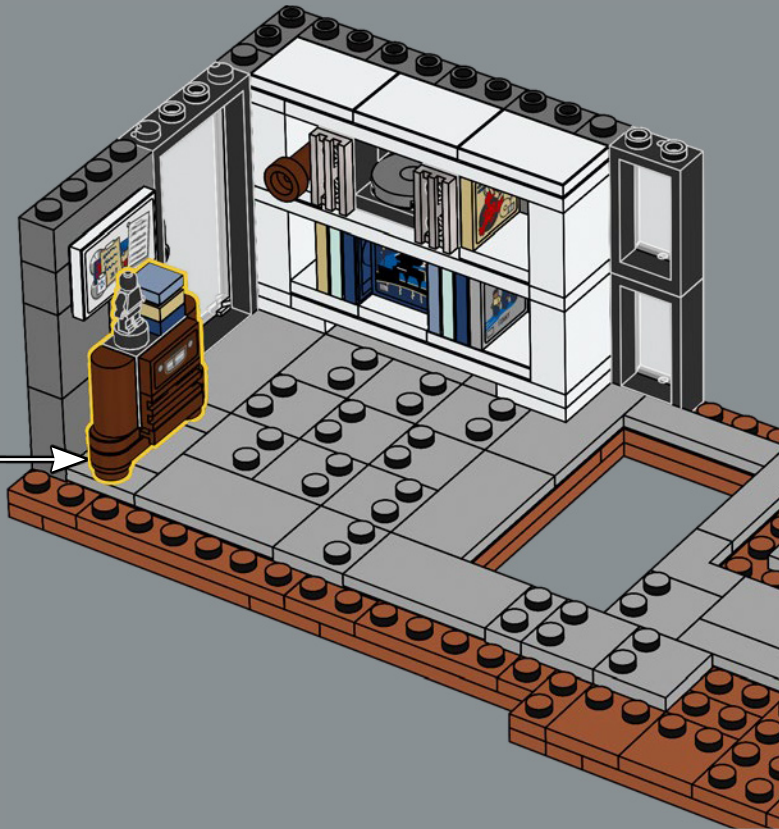

302

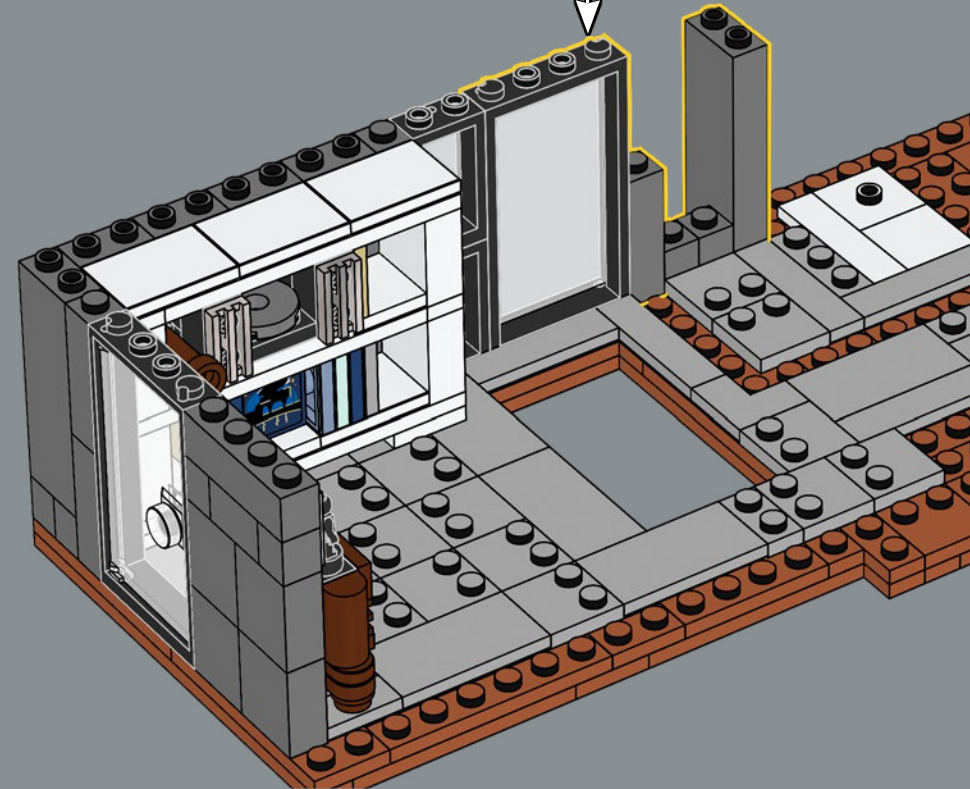
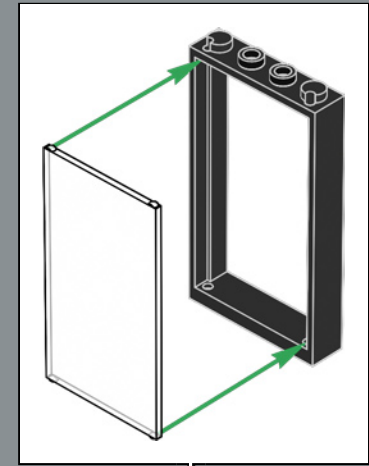
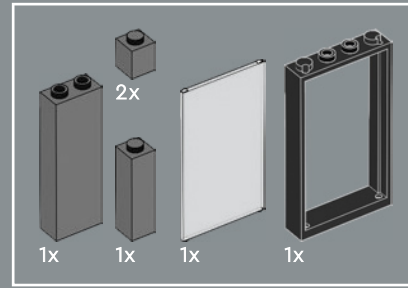

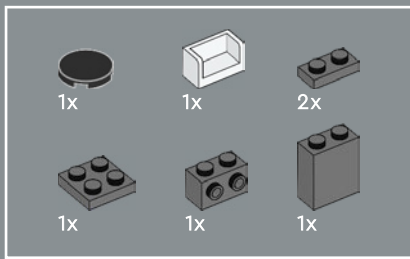

303

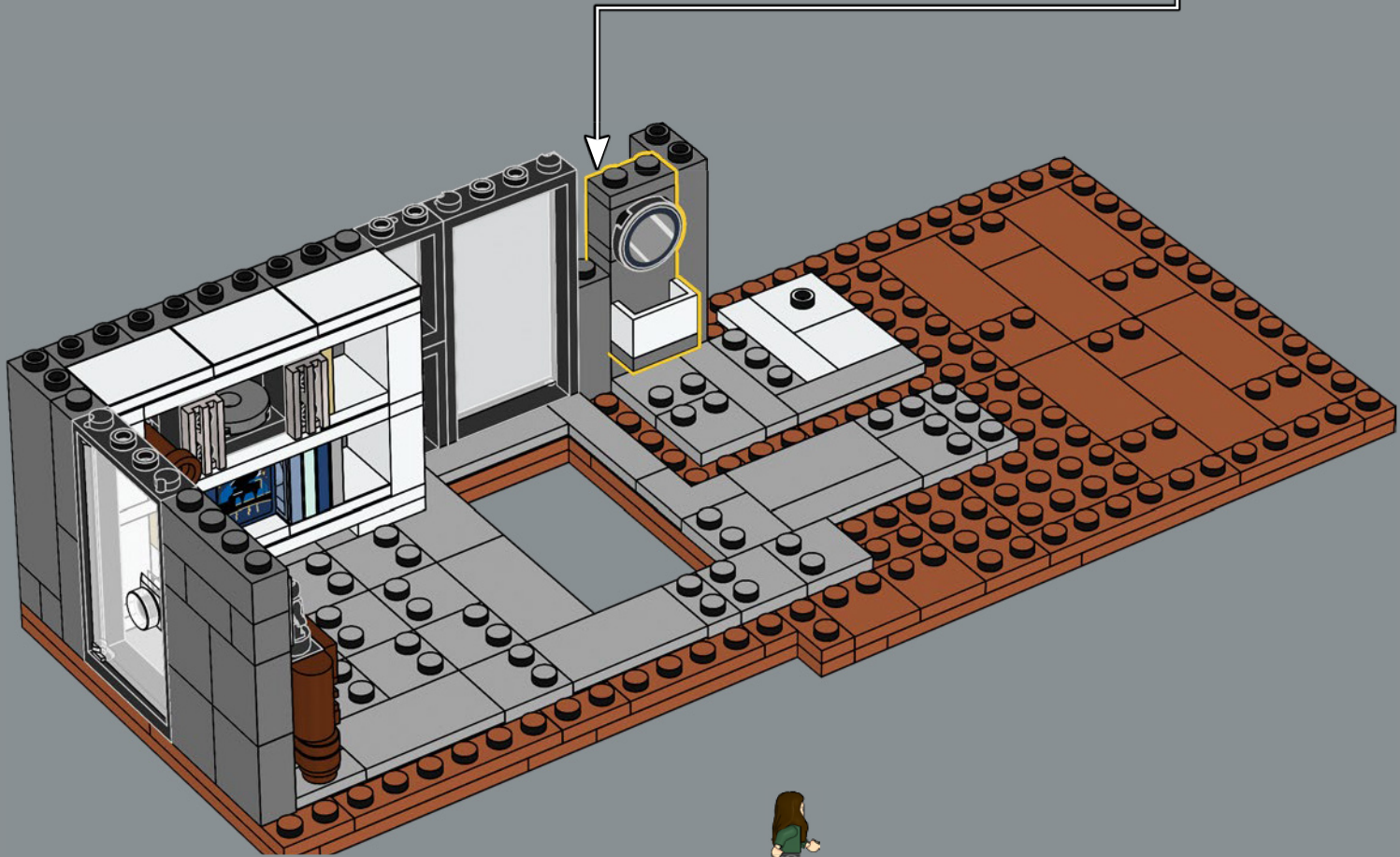
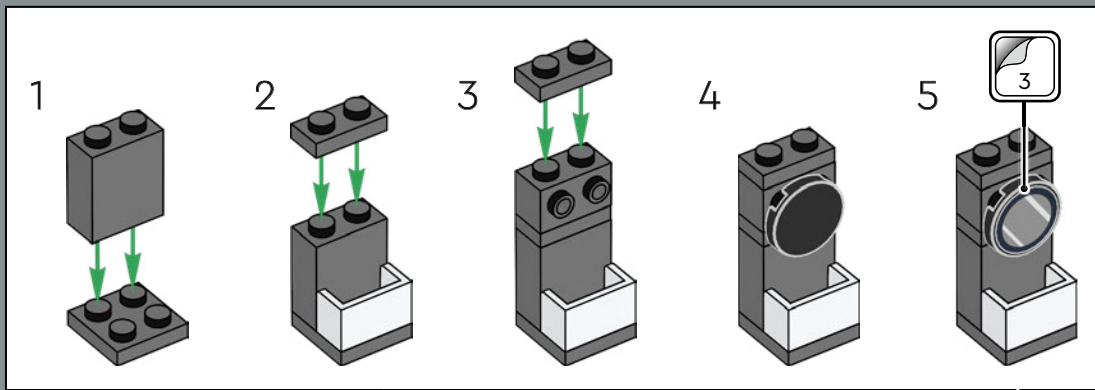

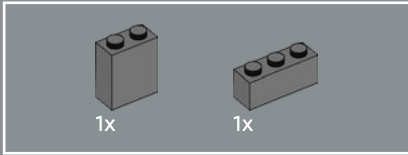
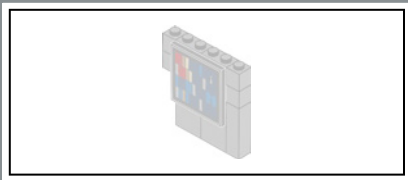

304

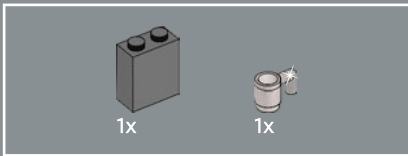
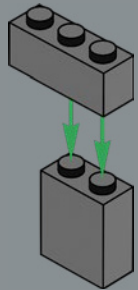

305

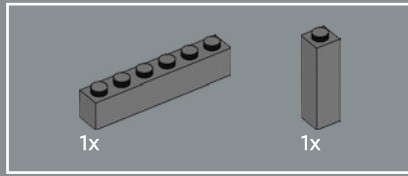
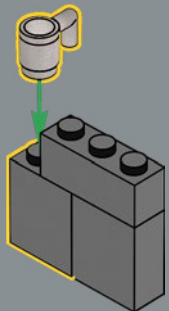

306

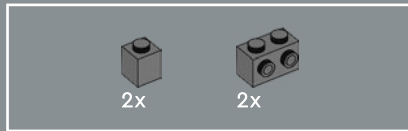
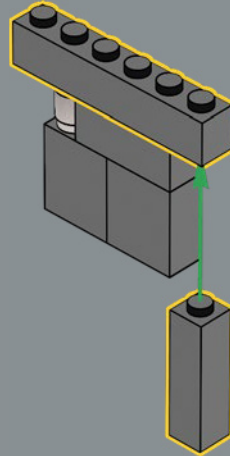

307

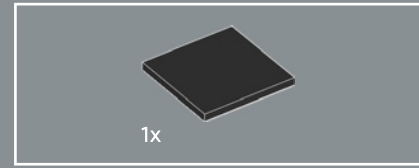
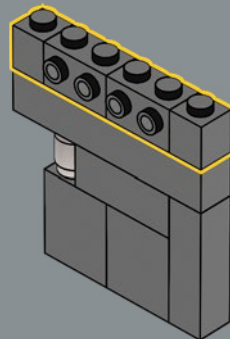

308

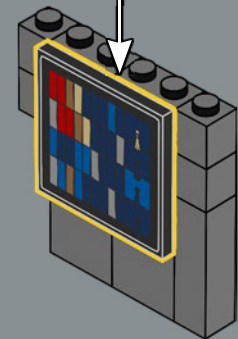
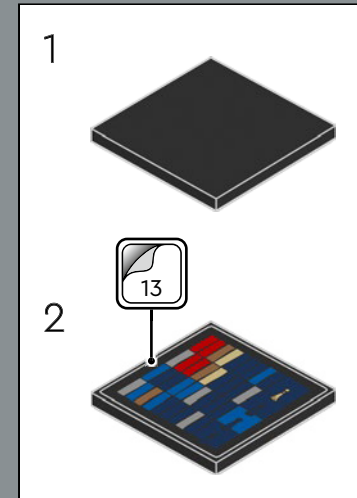

309

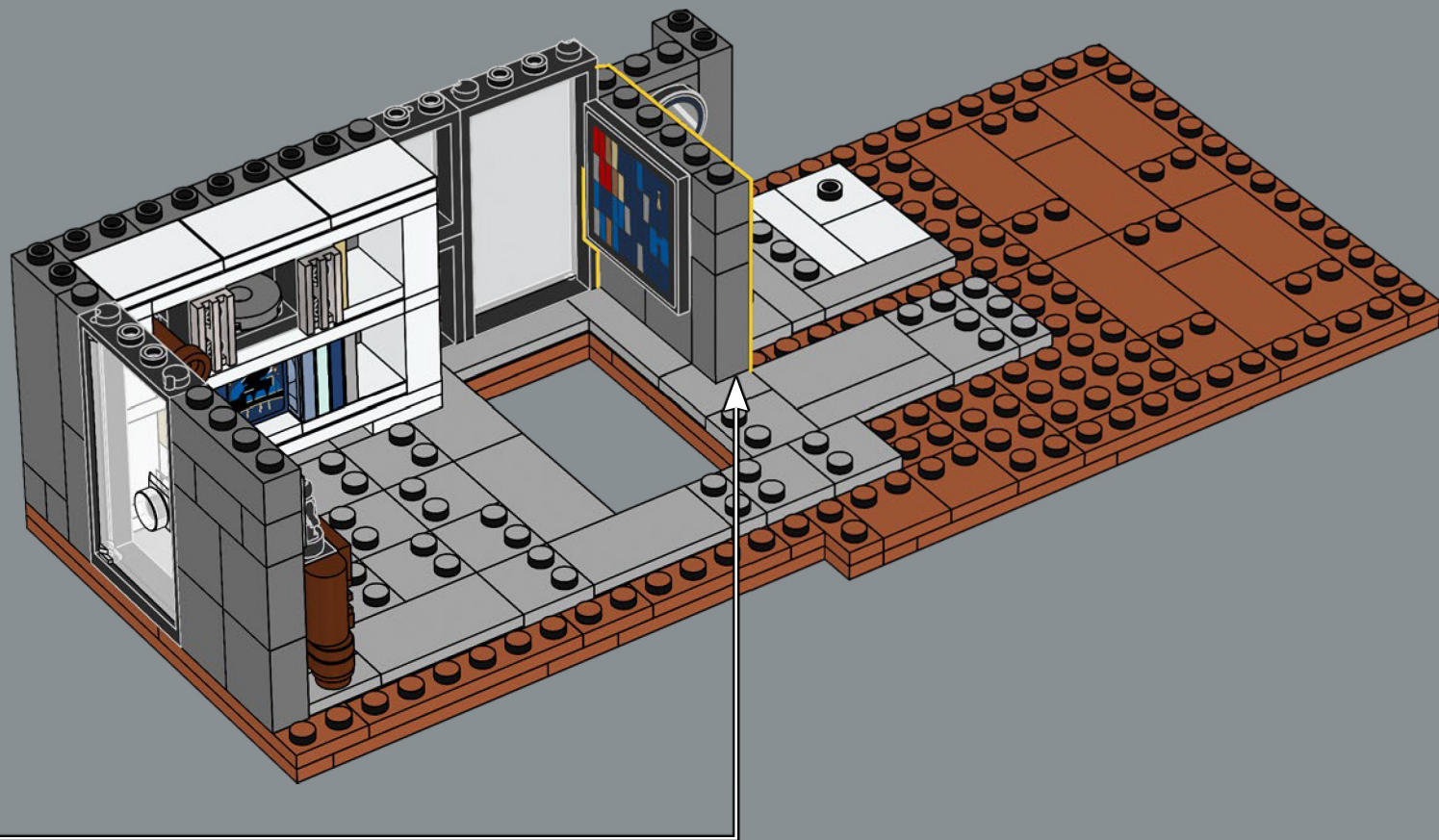

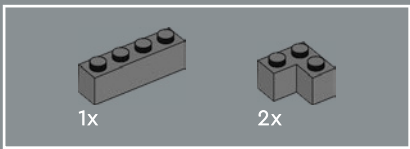

310

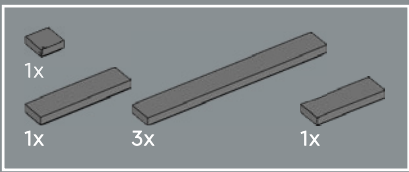
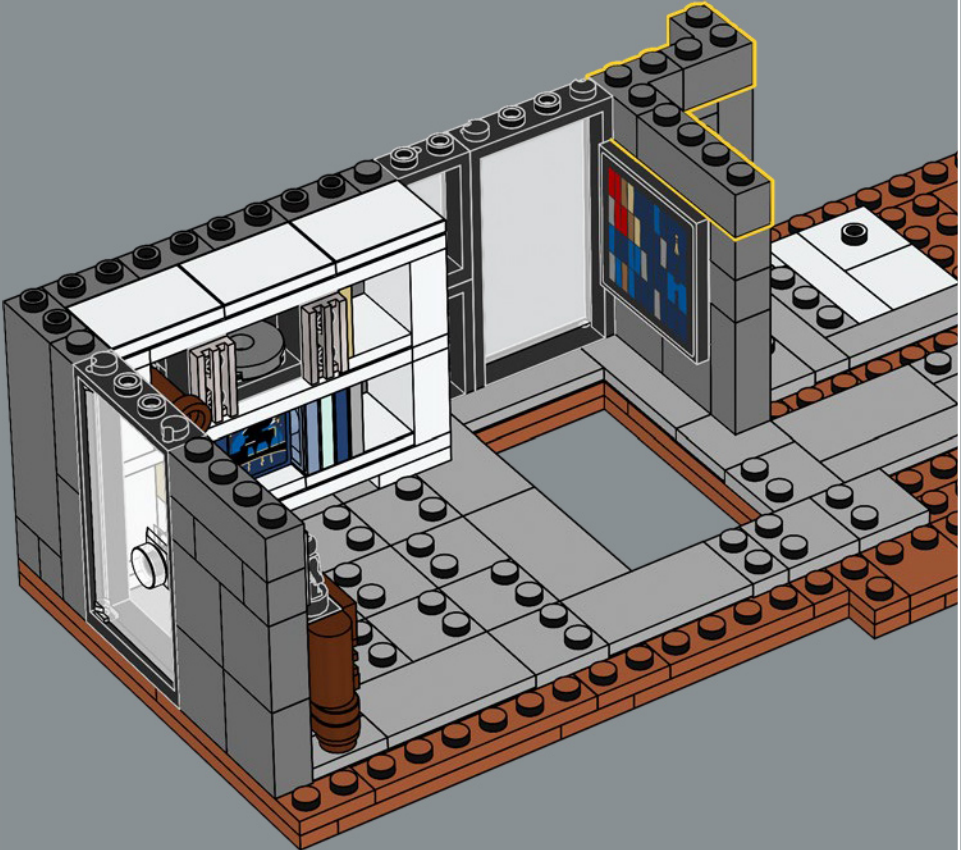

311

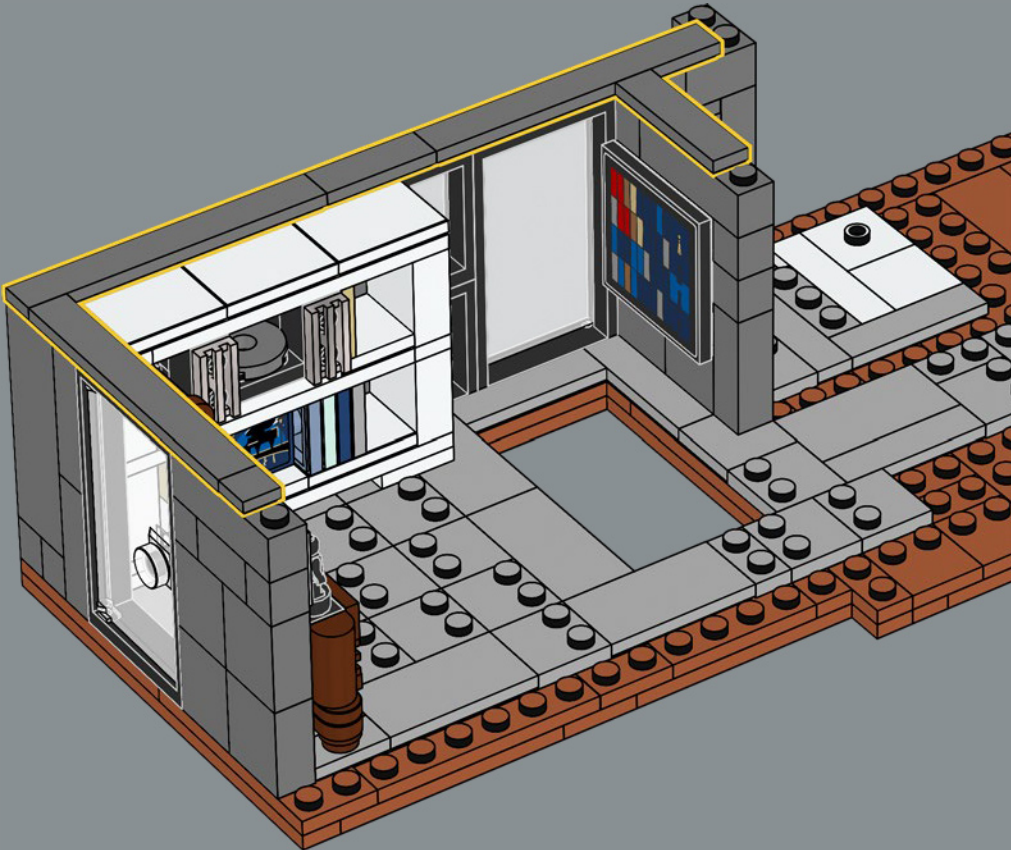

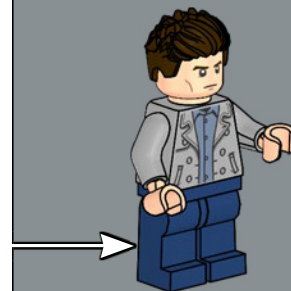
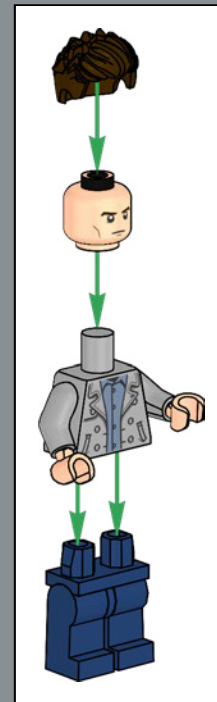

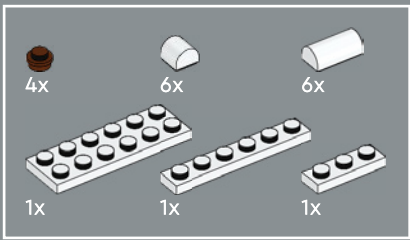

312

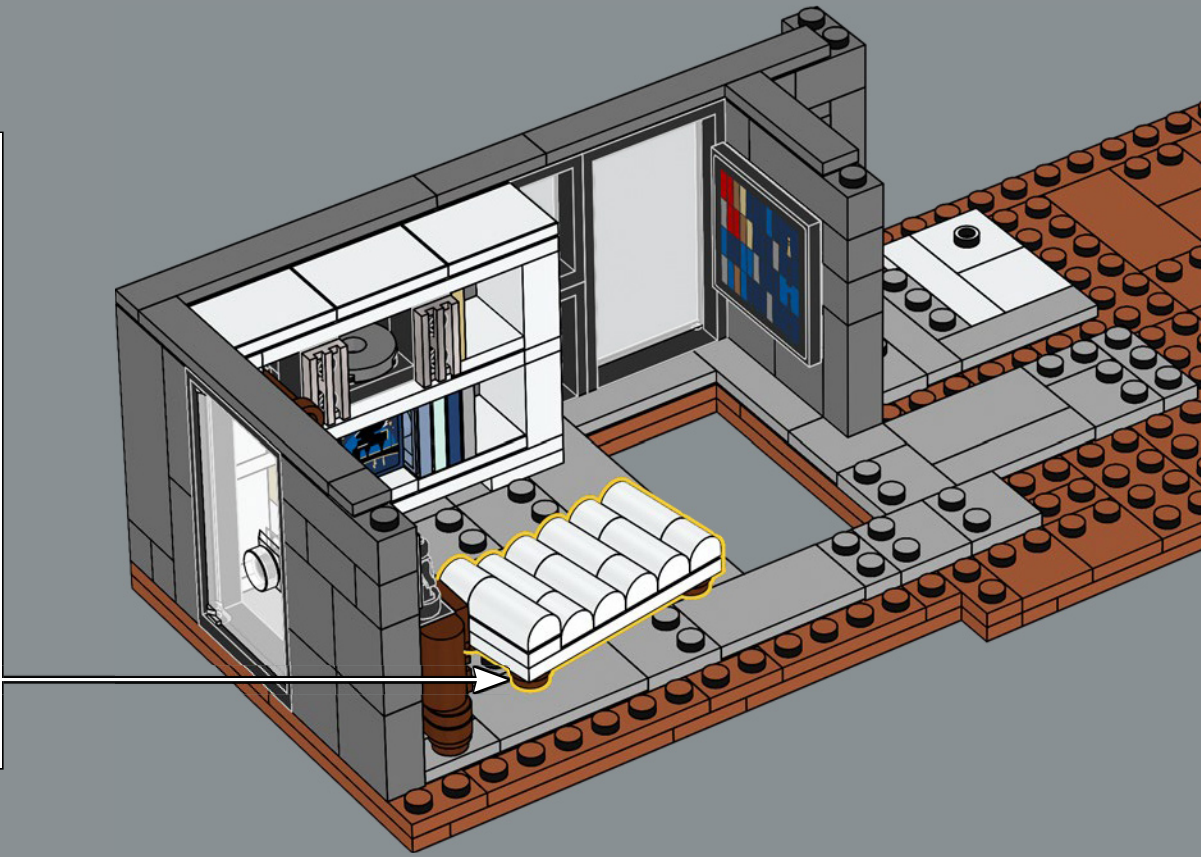
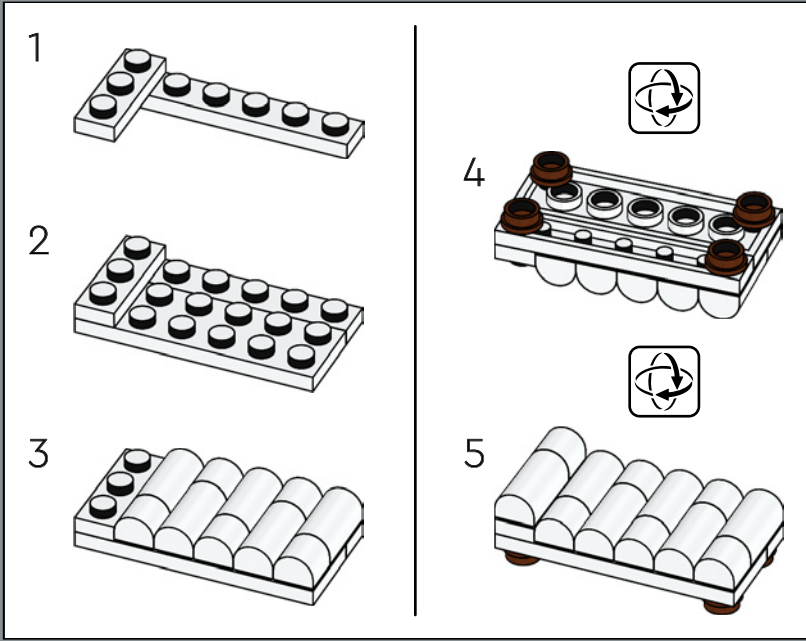

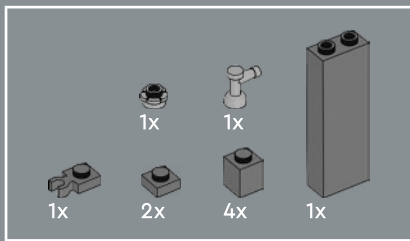

313

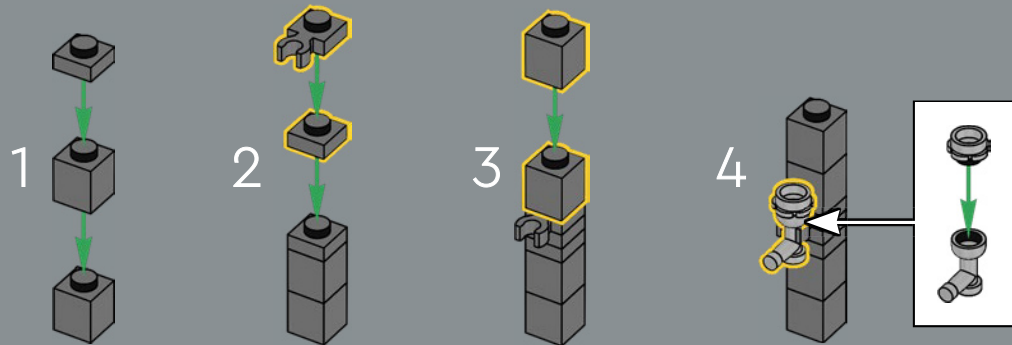

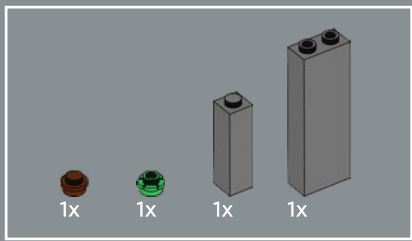

314

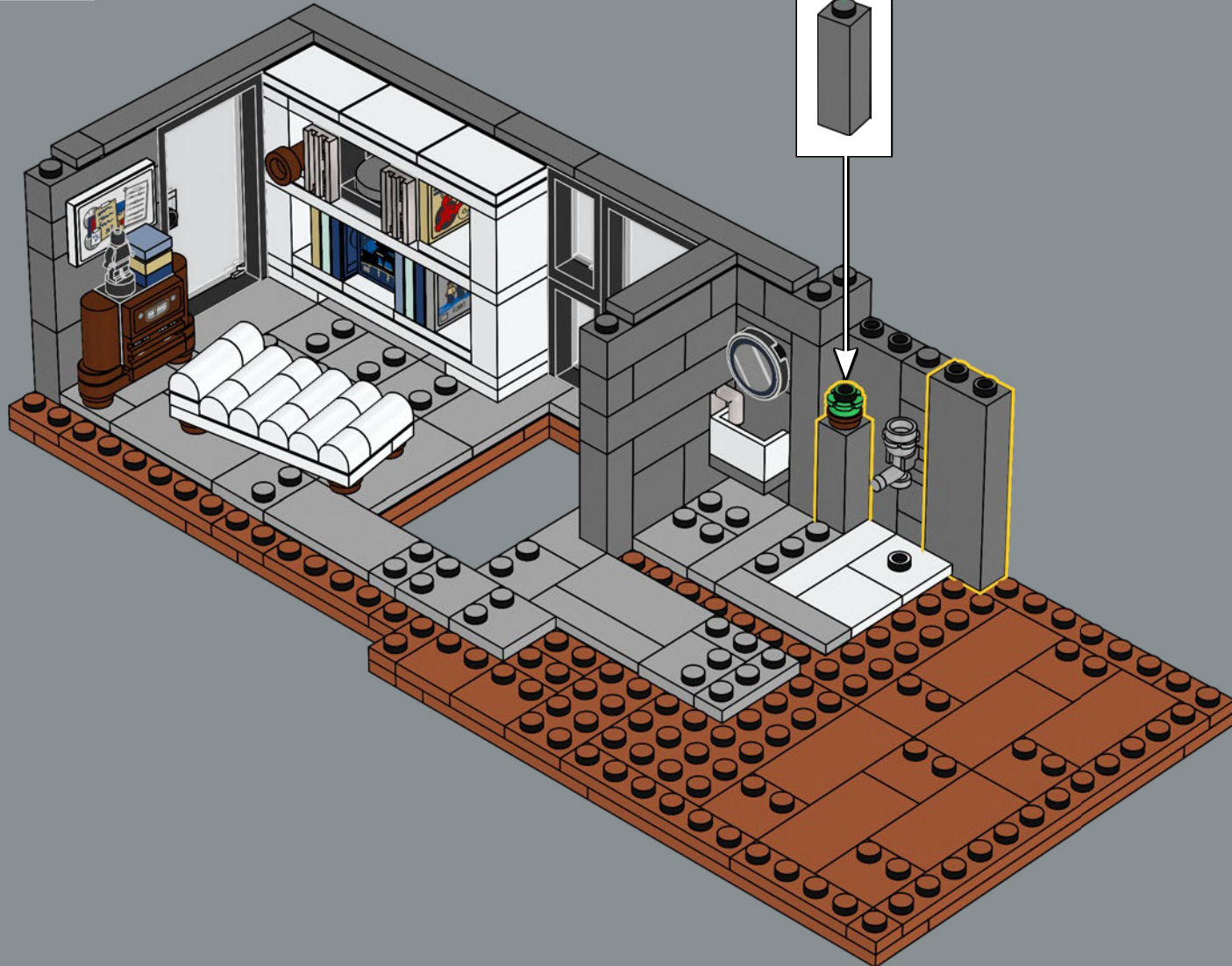

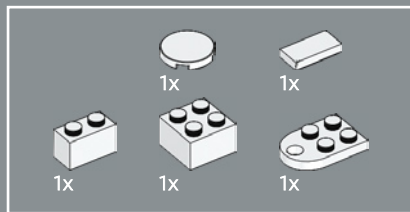

315

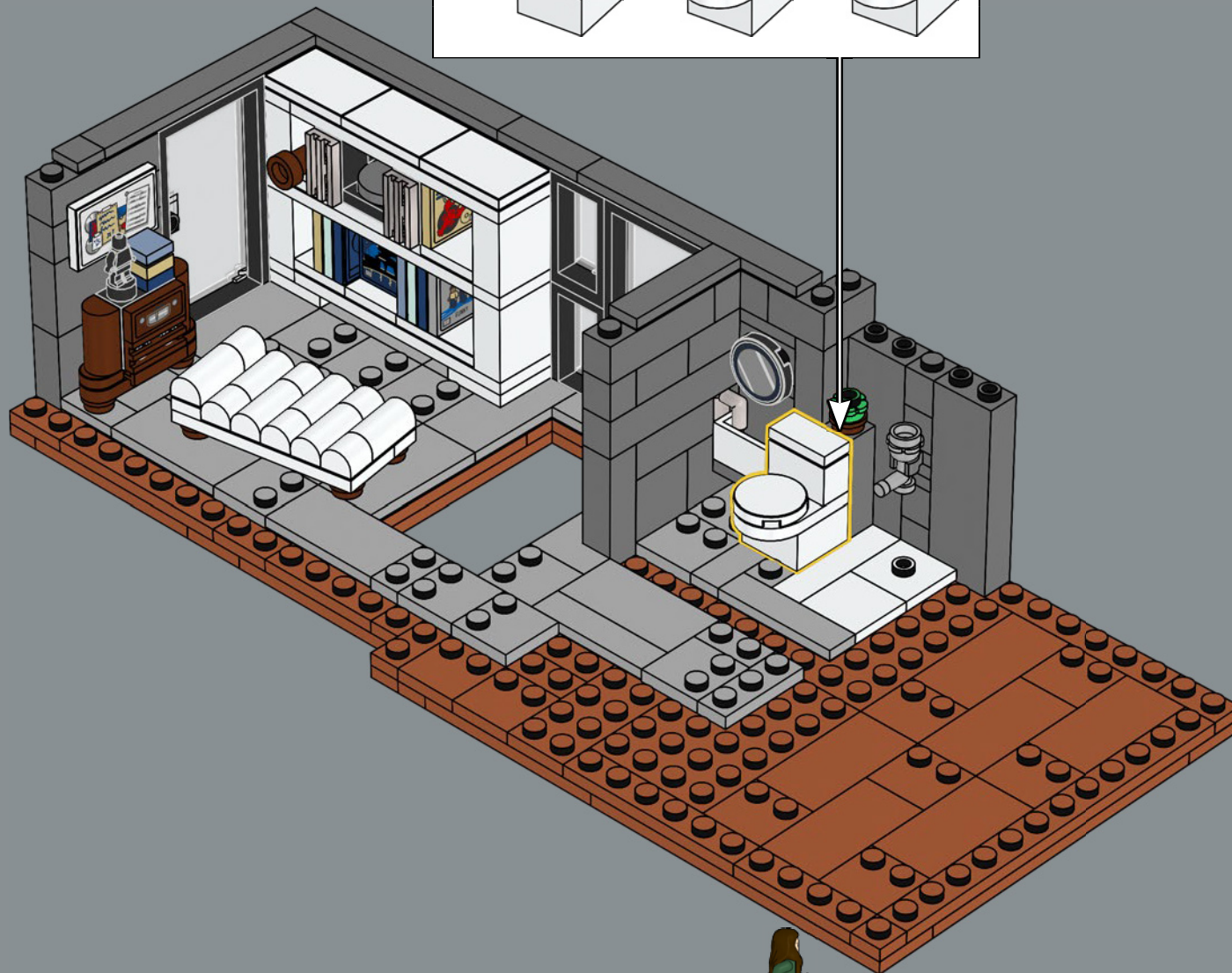
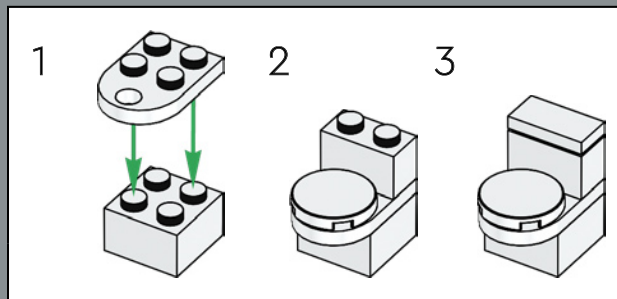

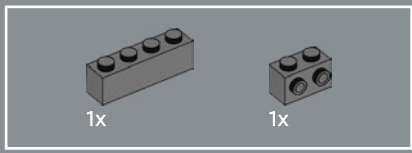

316

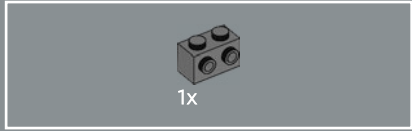
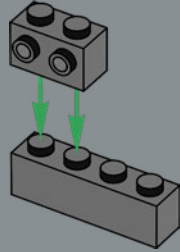

317

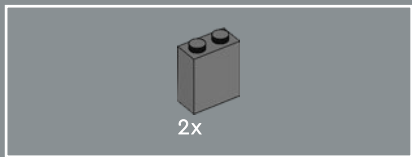
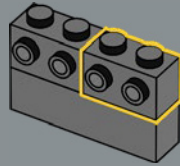

318

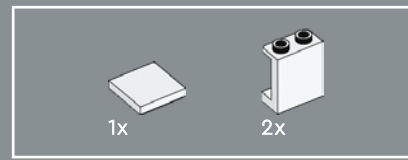
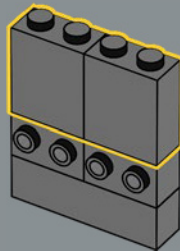

319

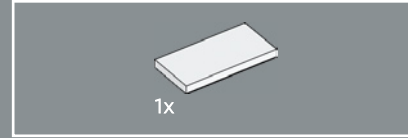
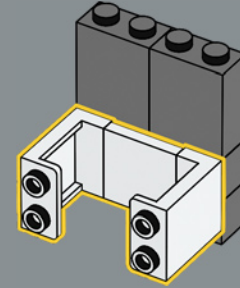

320

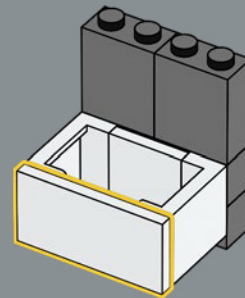

321

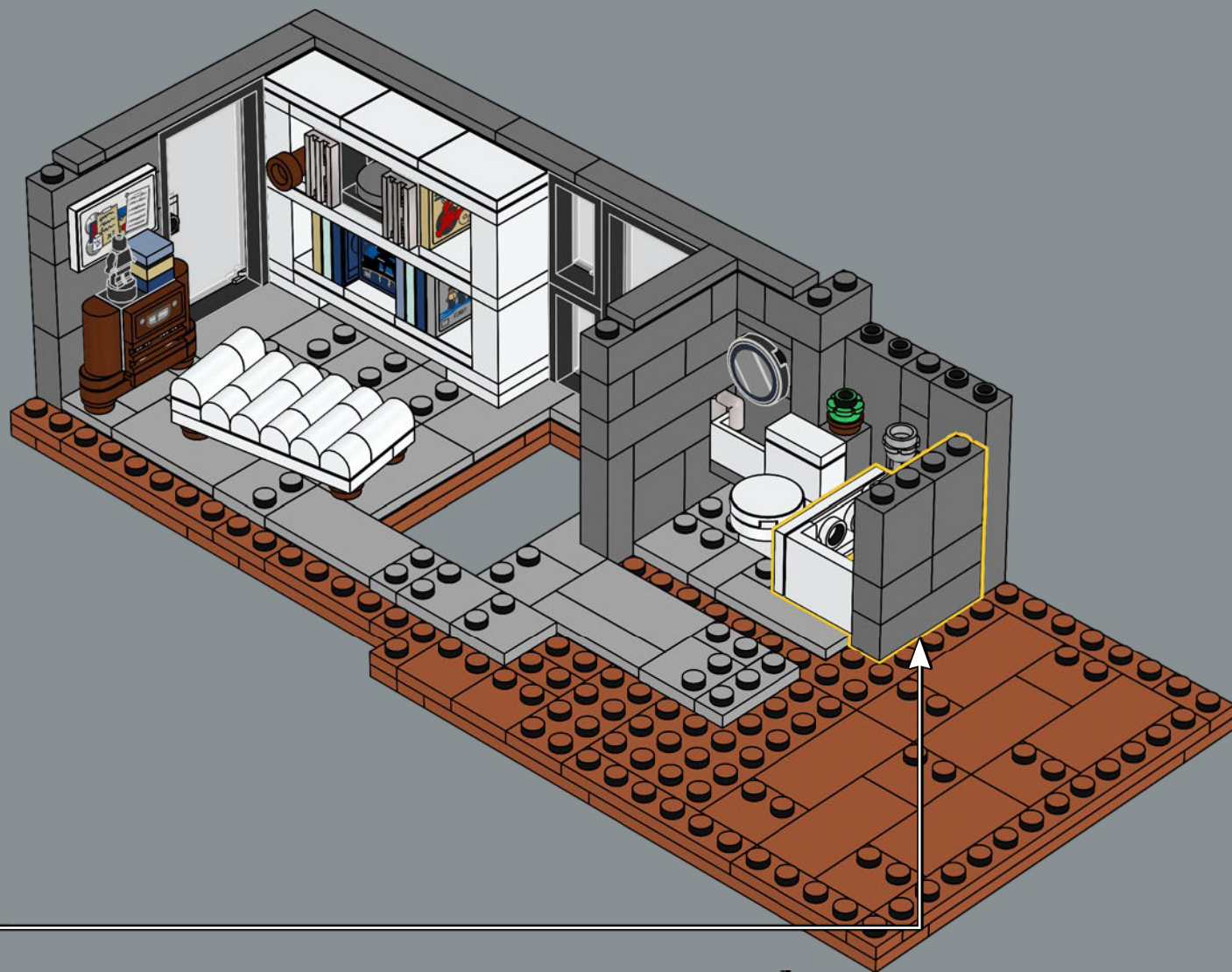

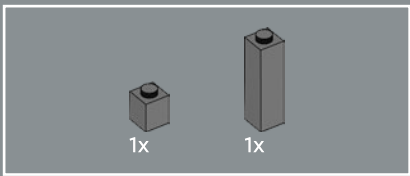

322

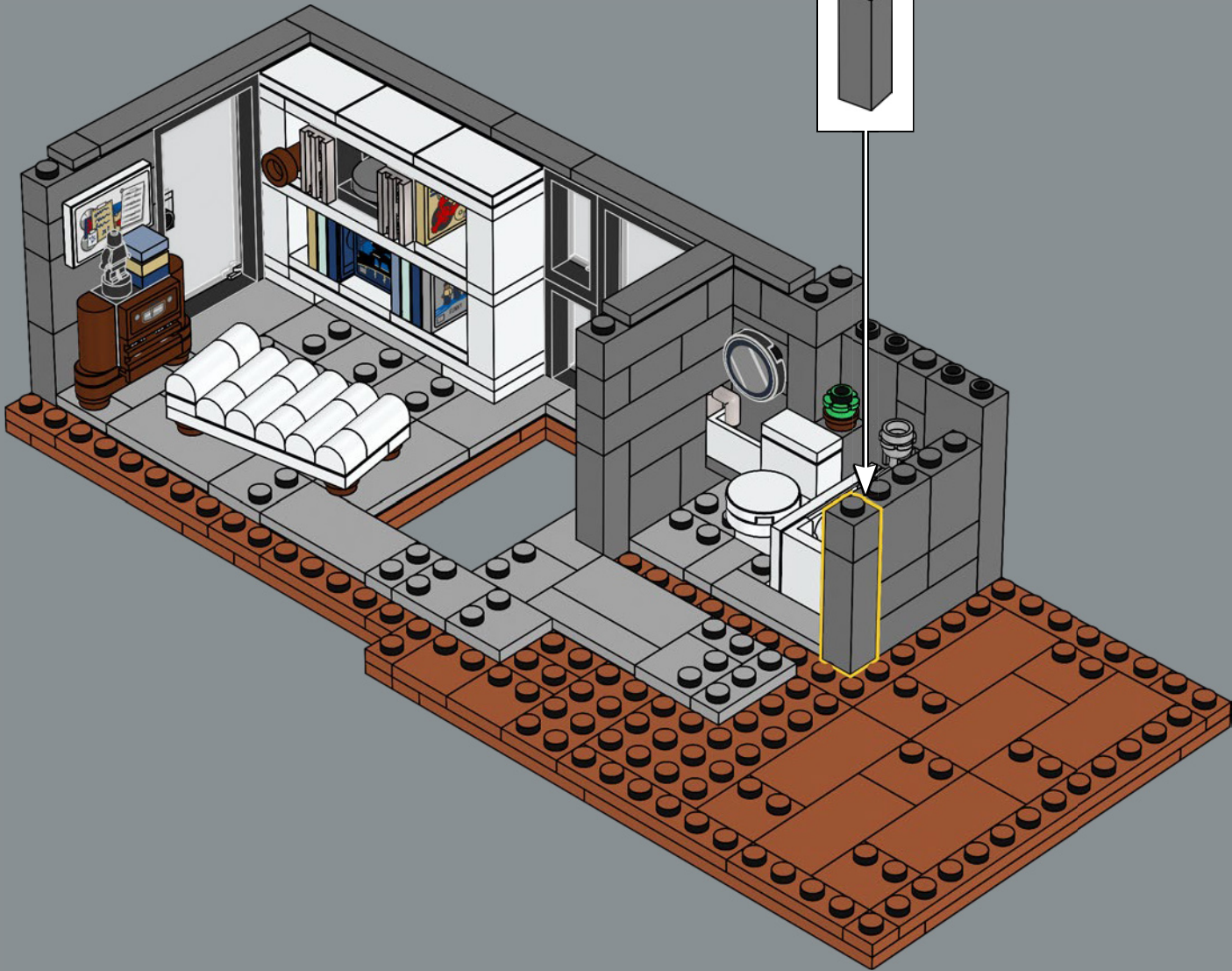

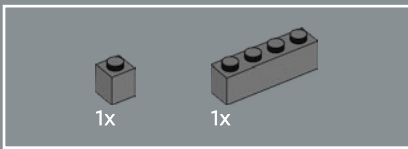

323

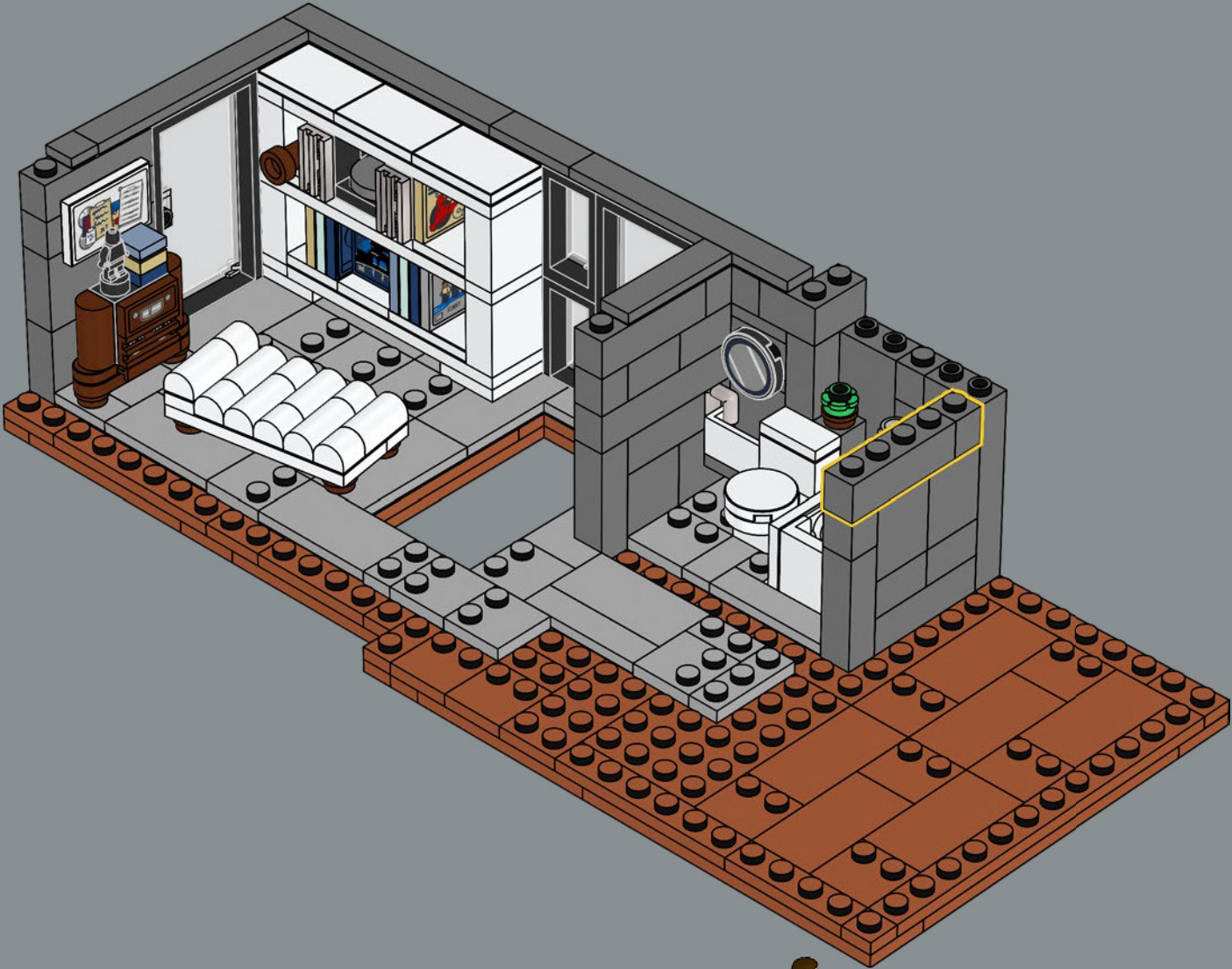

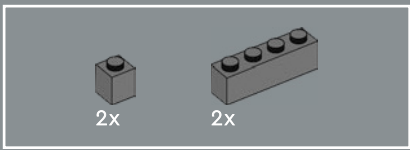

324

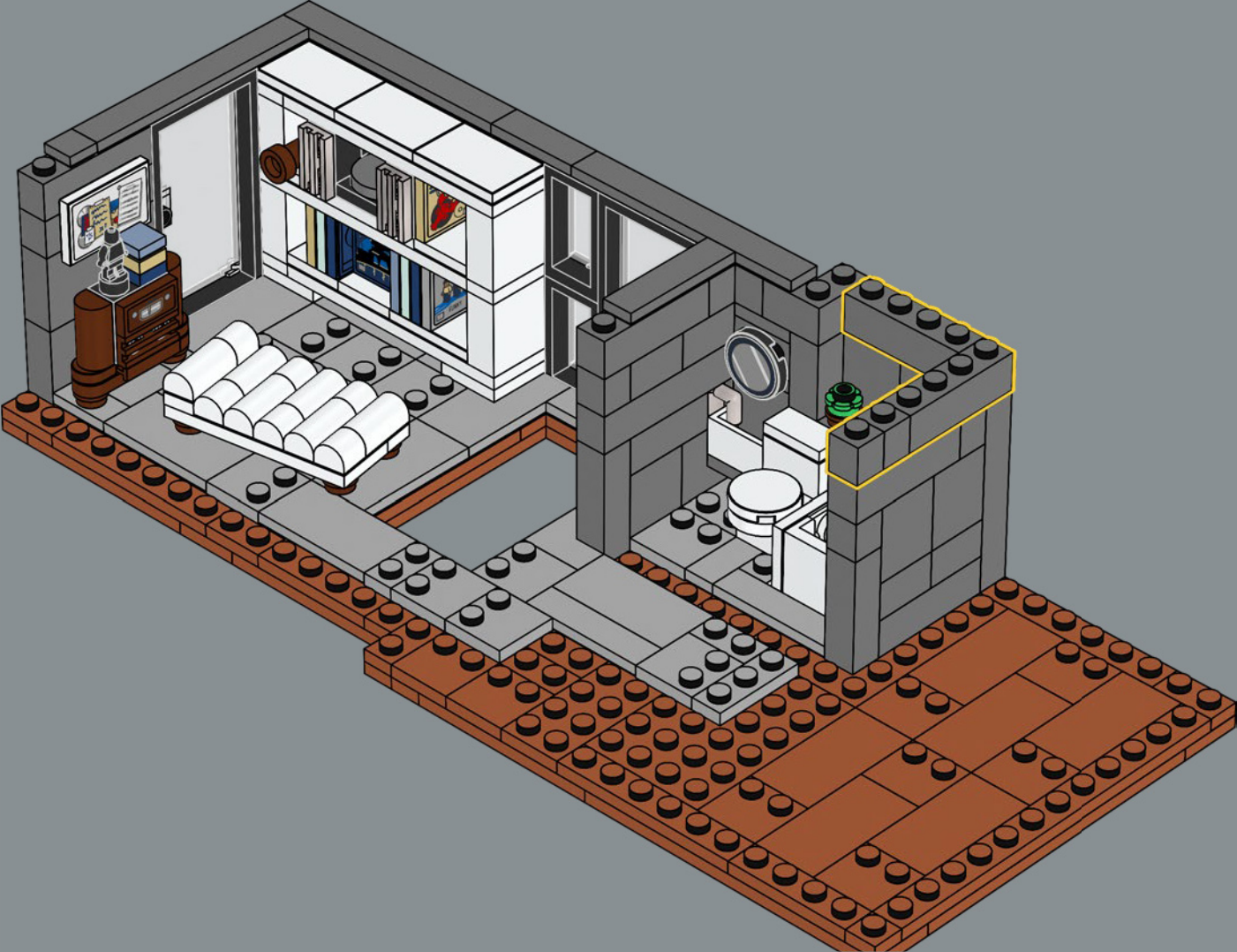

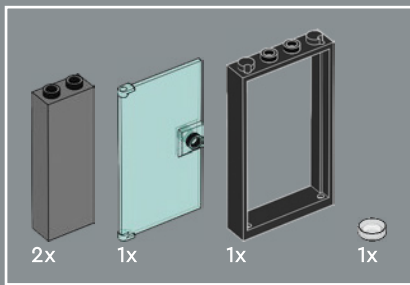

325

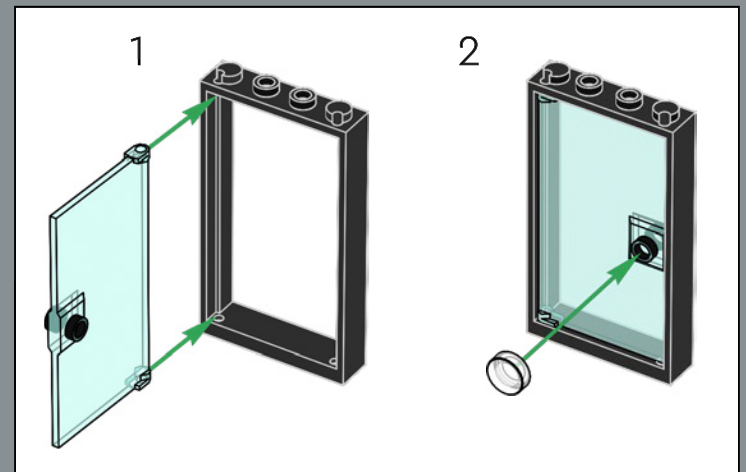
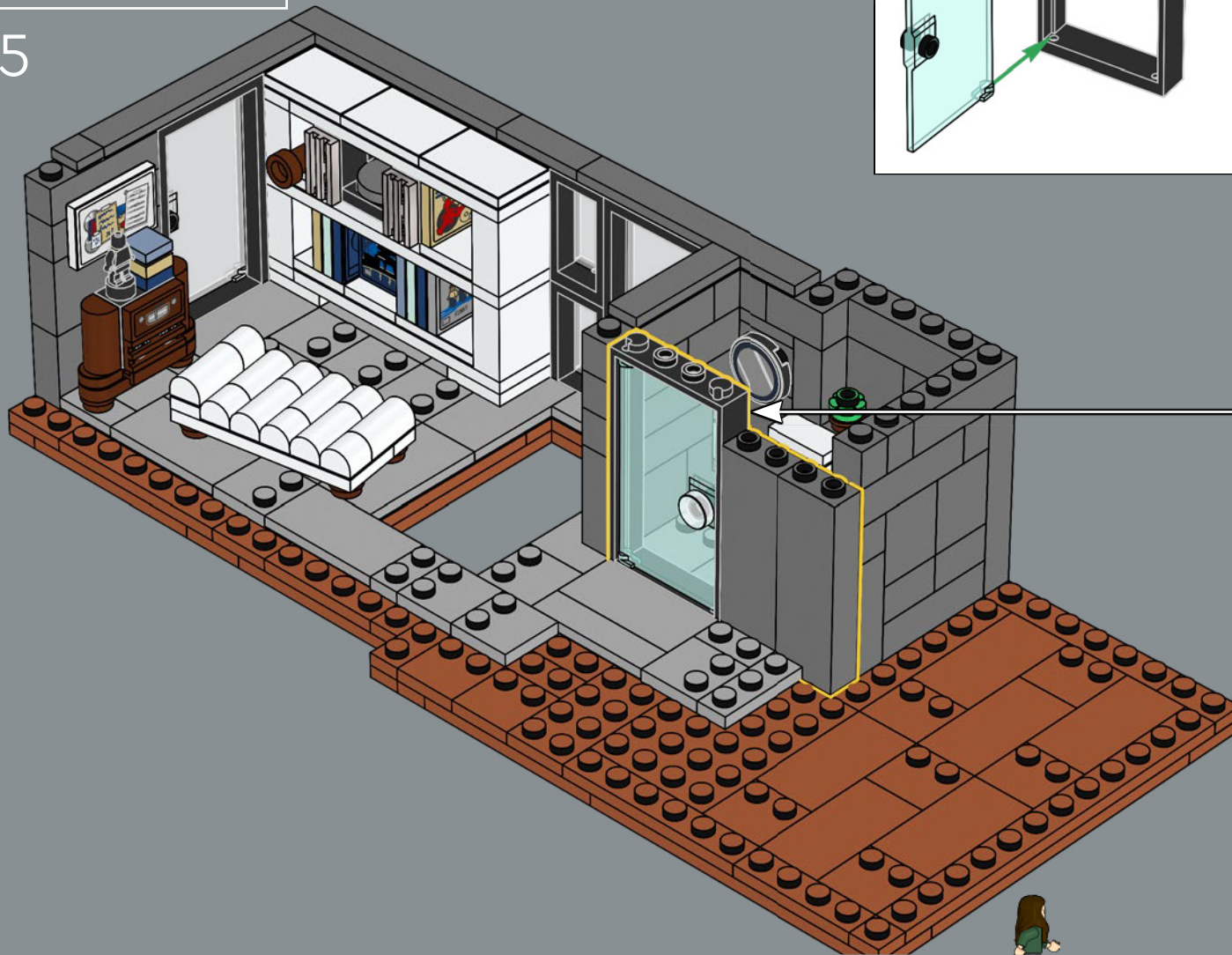

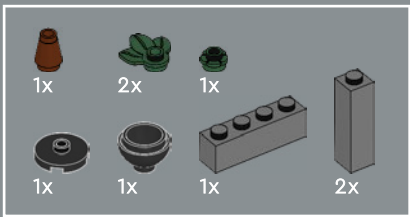

326

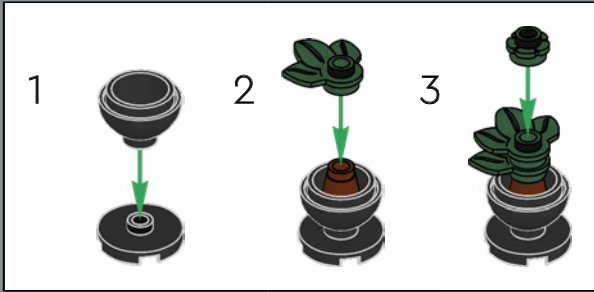
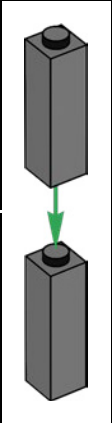

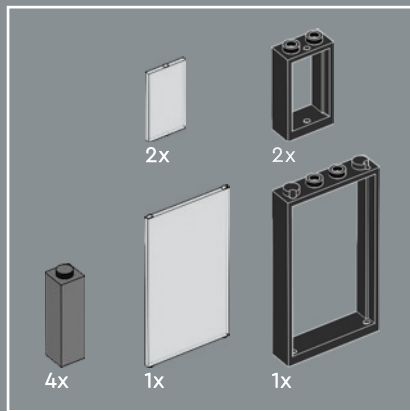

327

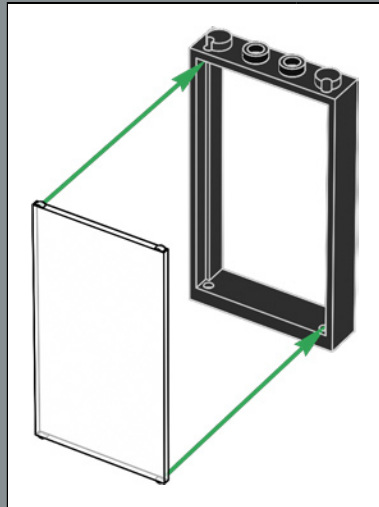
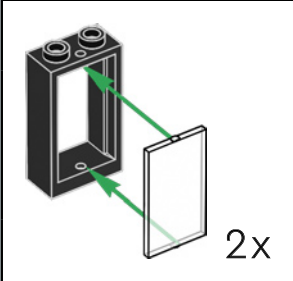
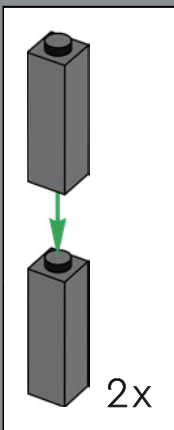
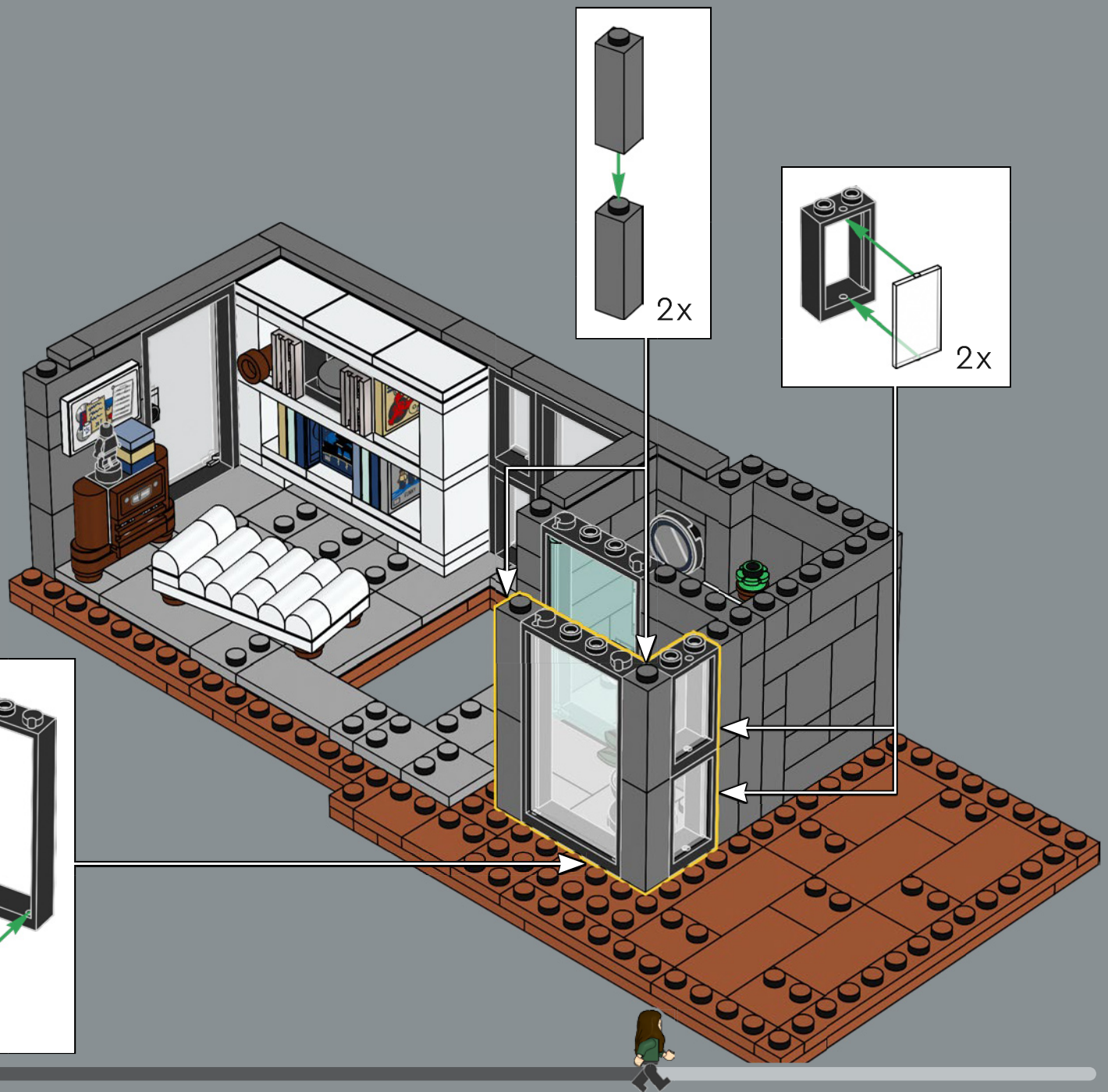

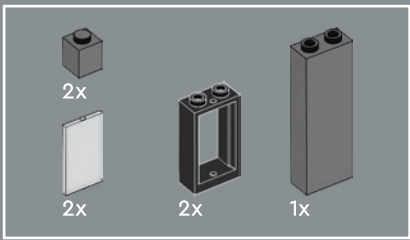

328

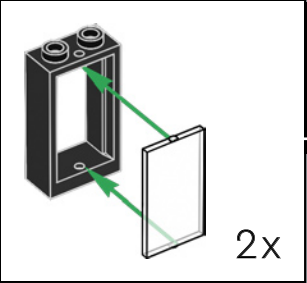
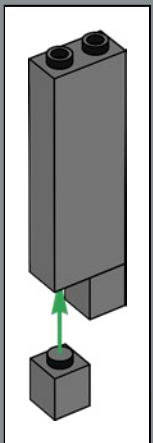

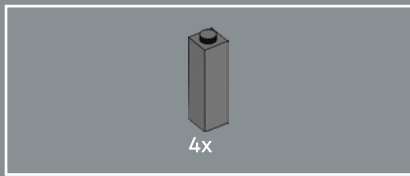

329

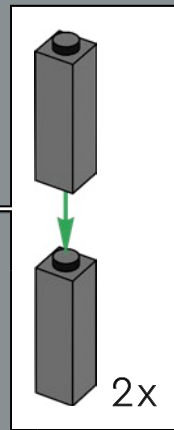

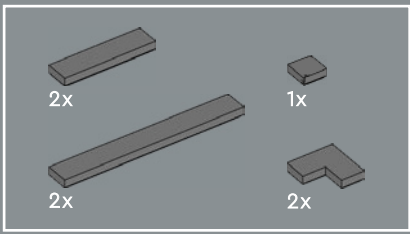

330

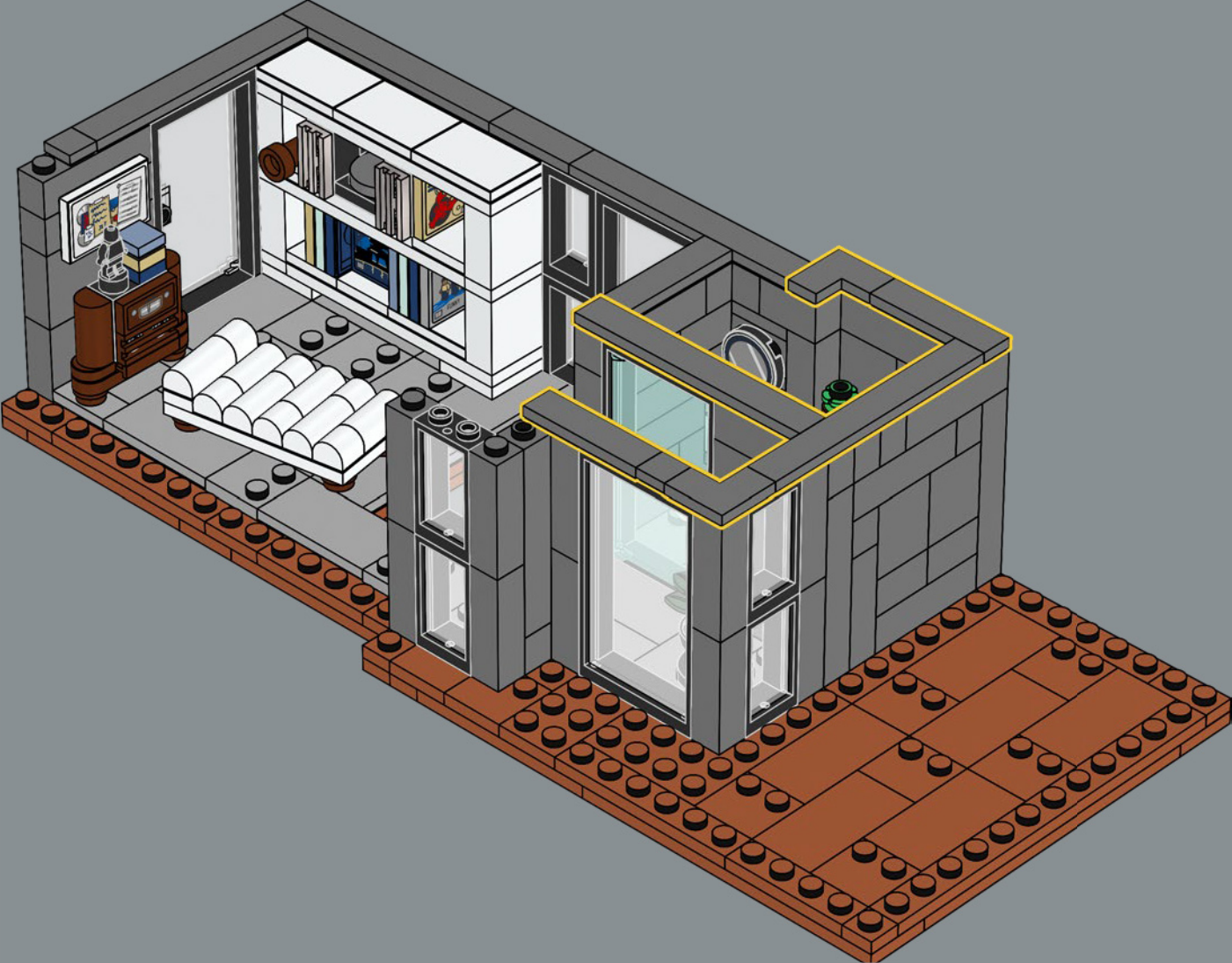

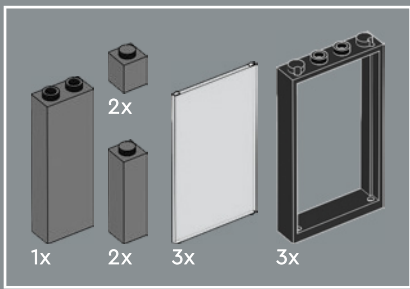

331

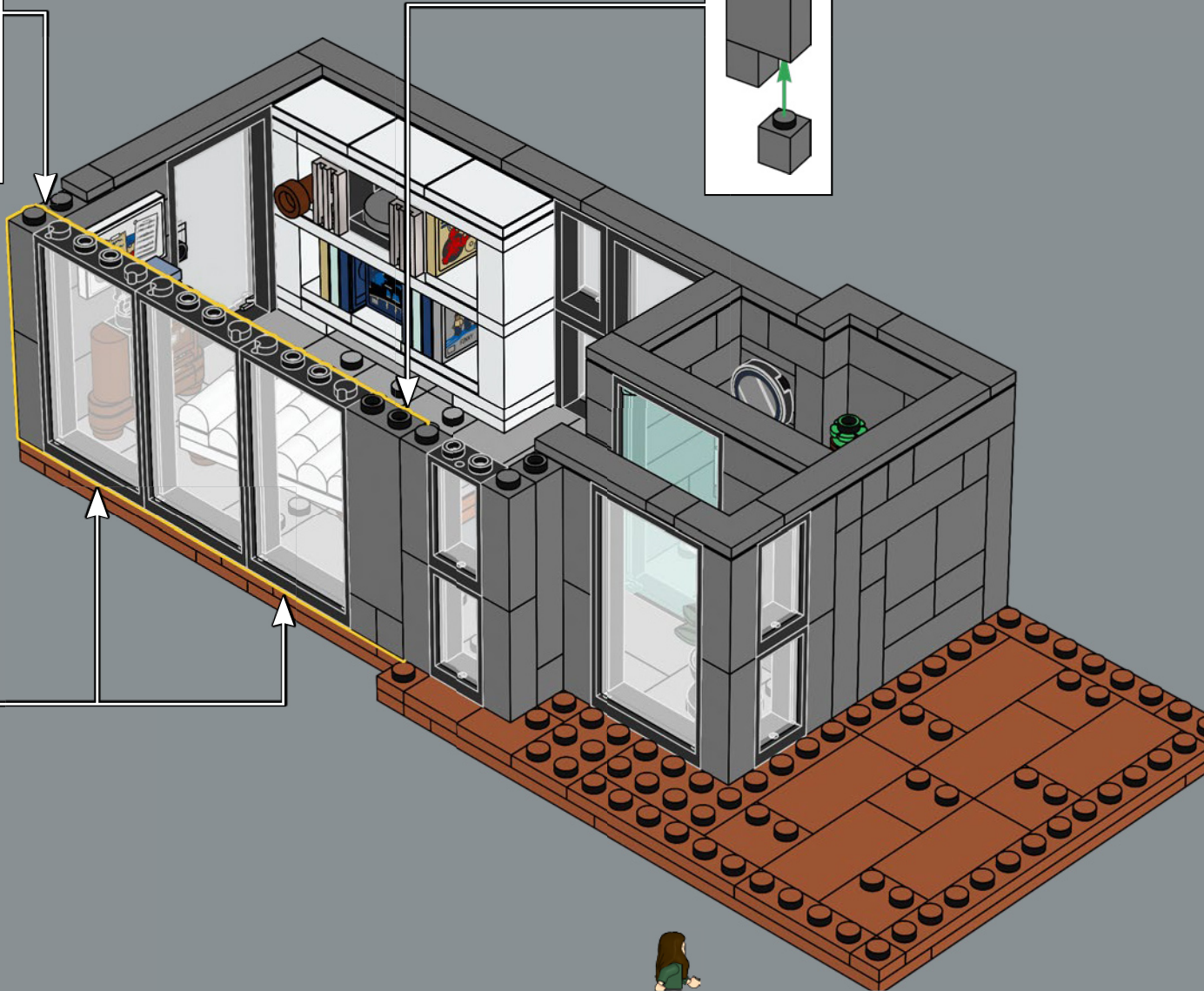
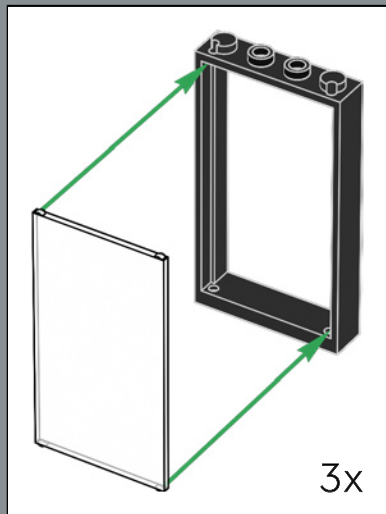
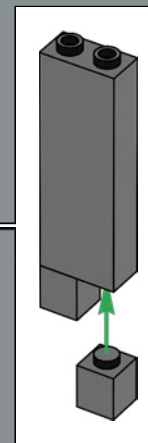
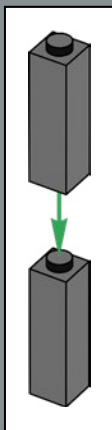

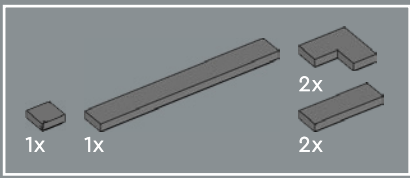

332

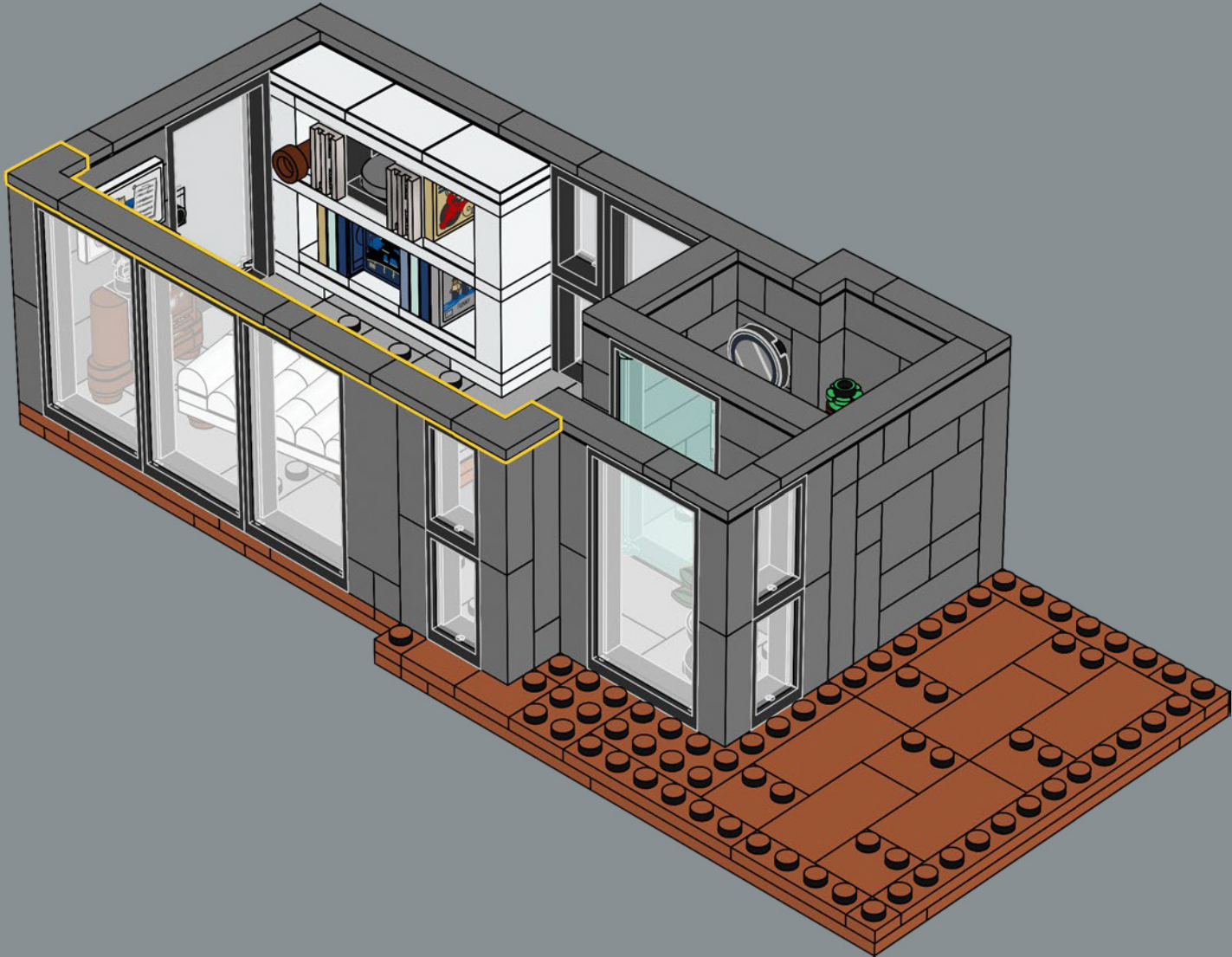

333

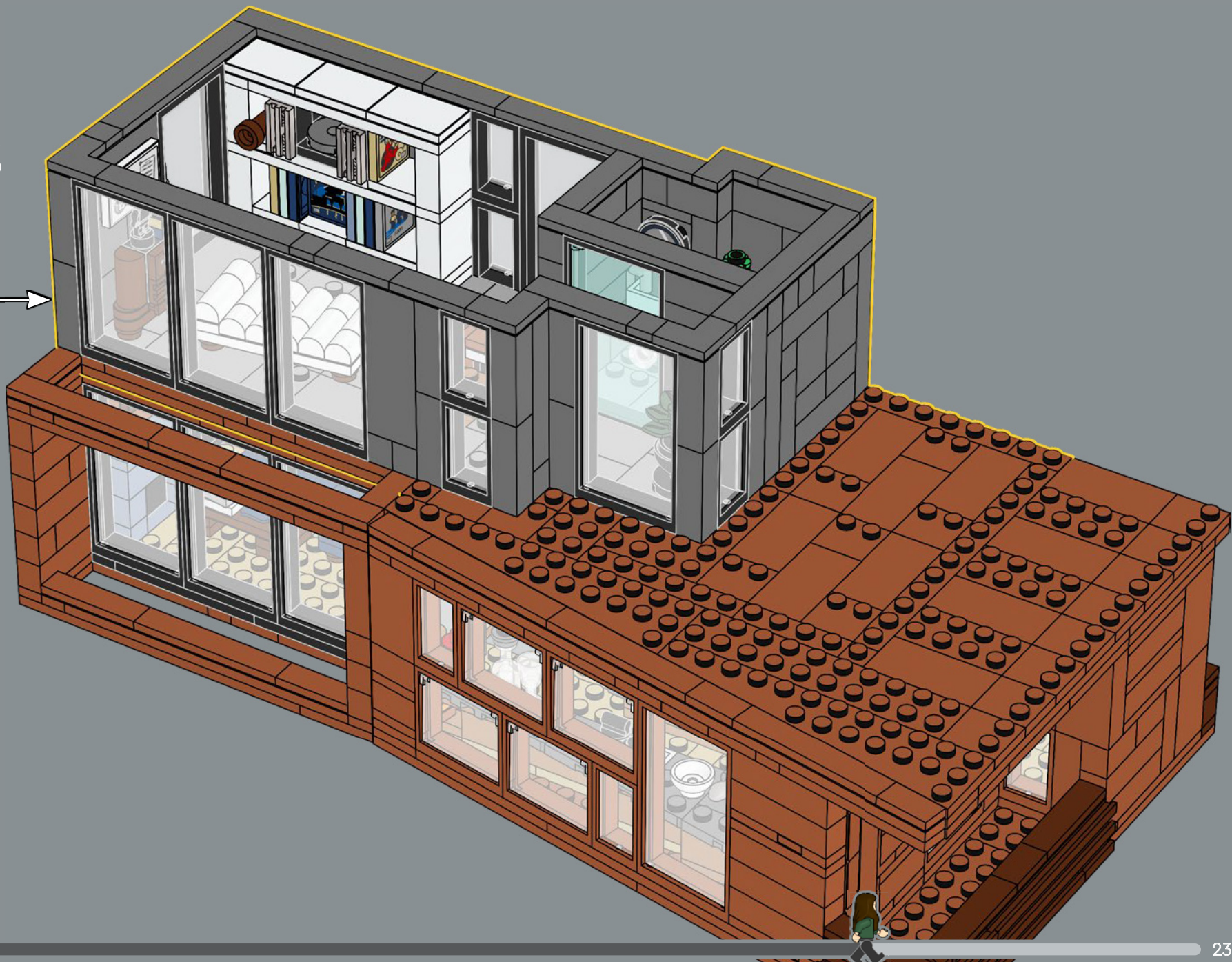

334



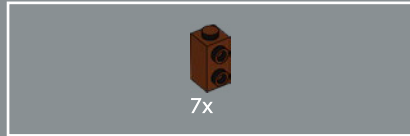
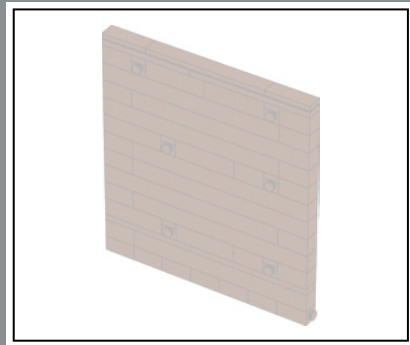

335

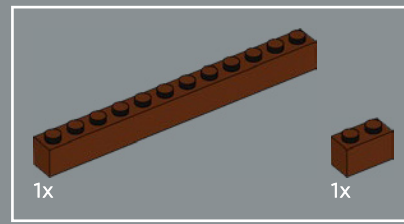
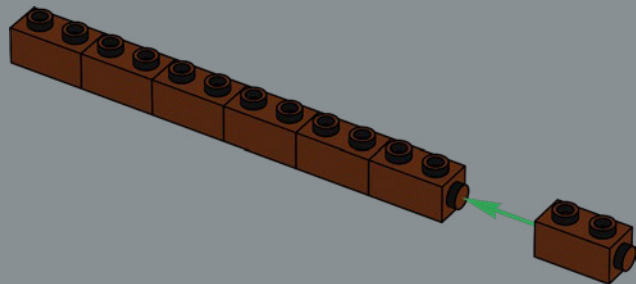

336

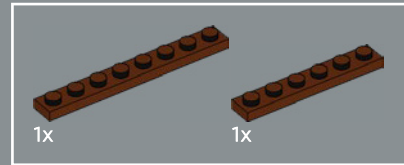
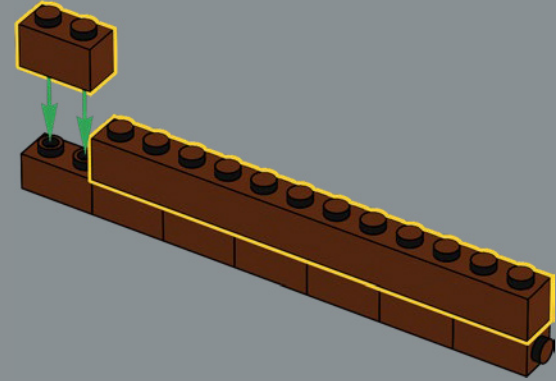

337

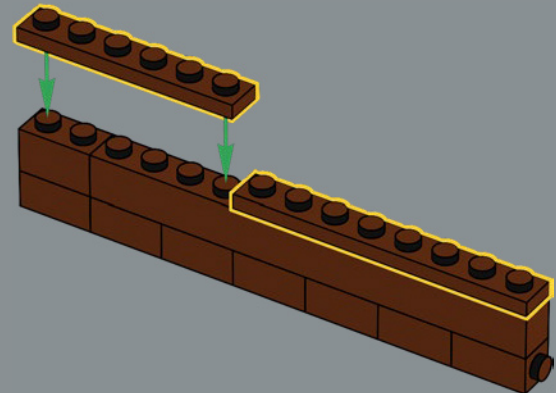

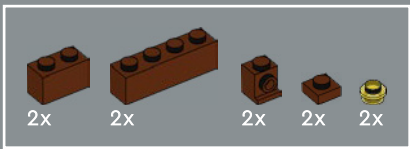

338

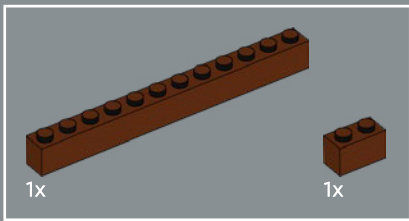
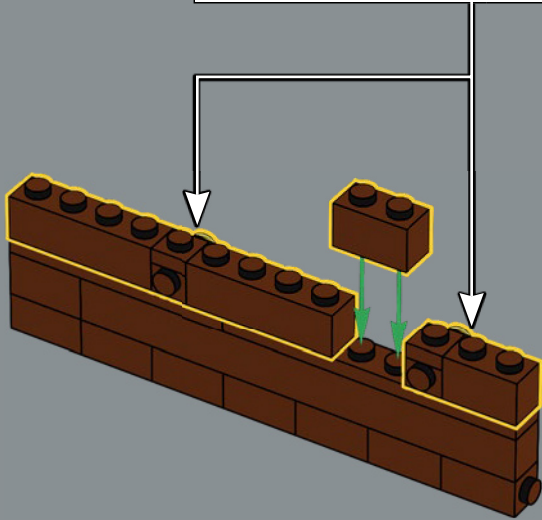
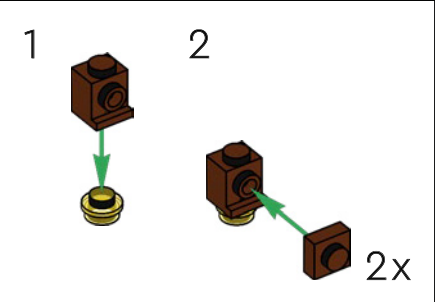

339

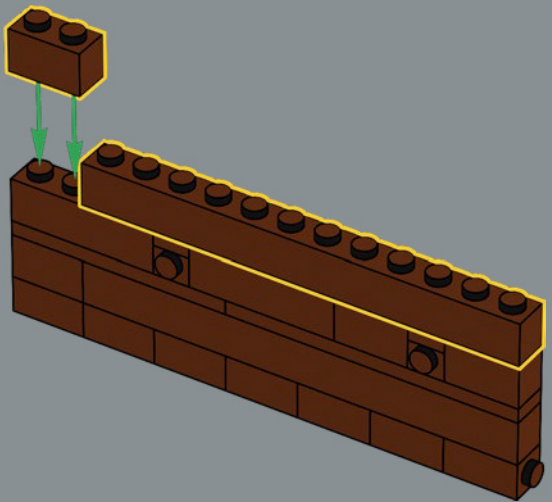

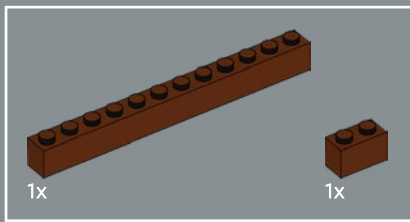

340

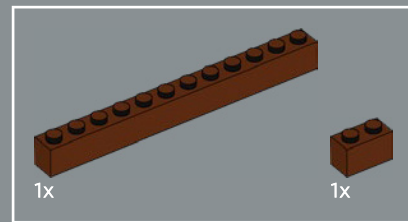
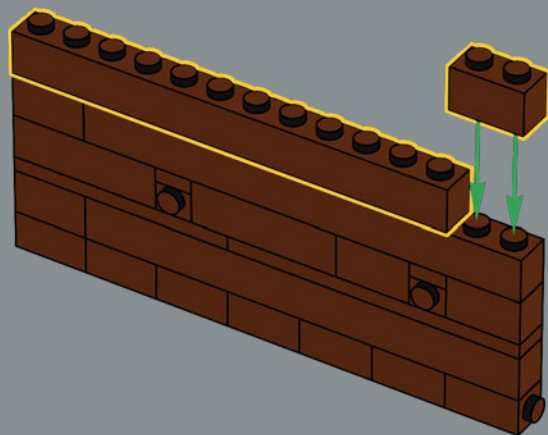

341

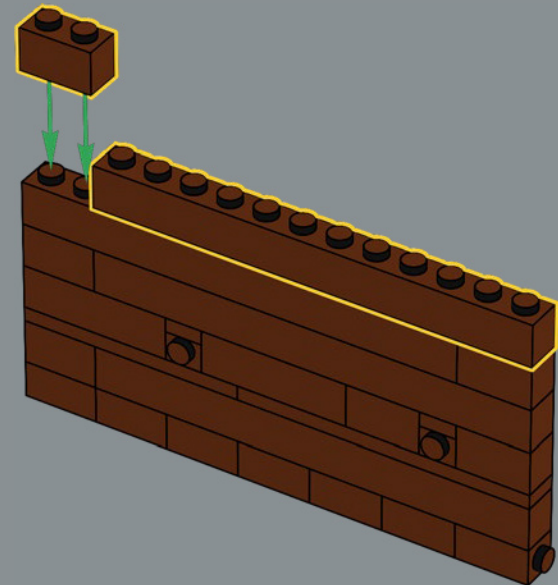

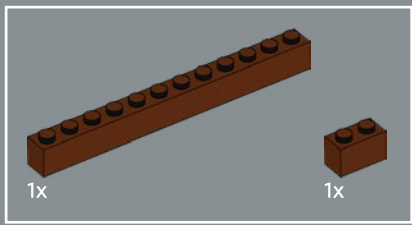

342

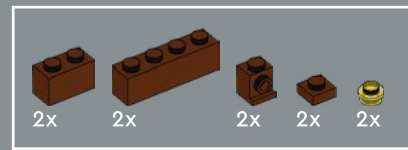
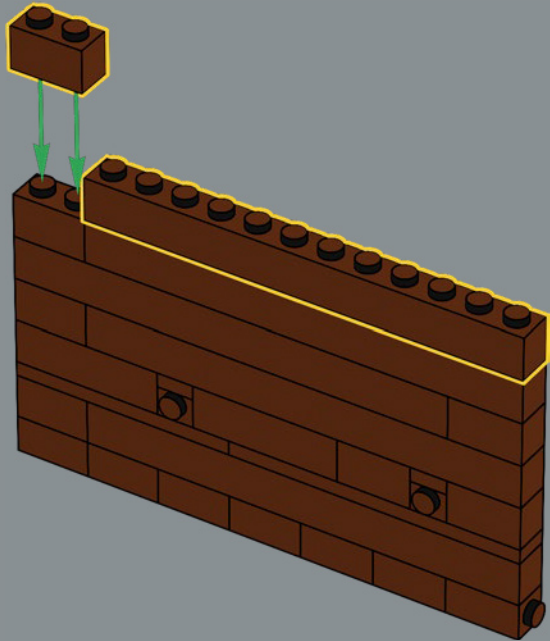

343

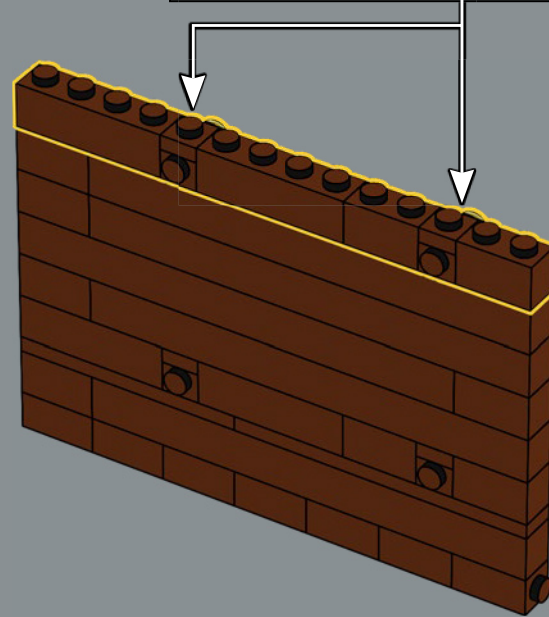
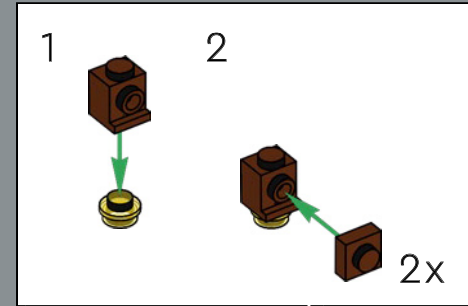

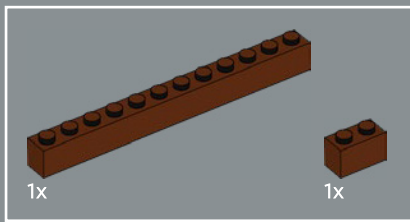

344

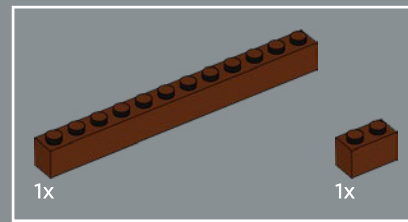
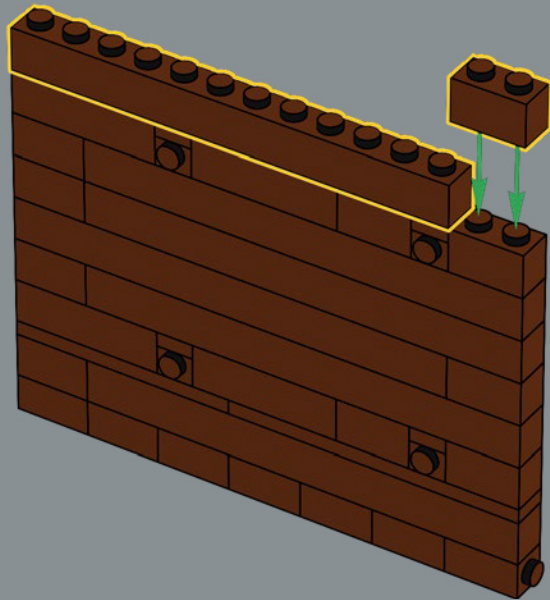

345

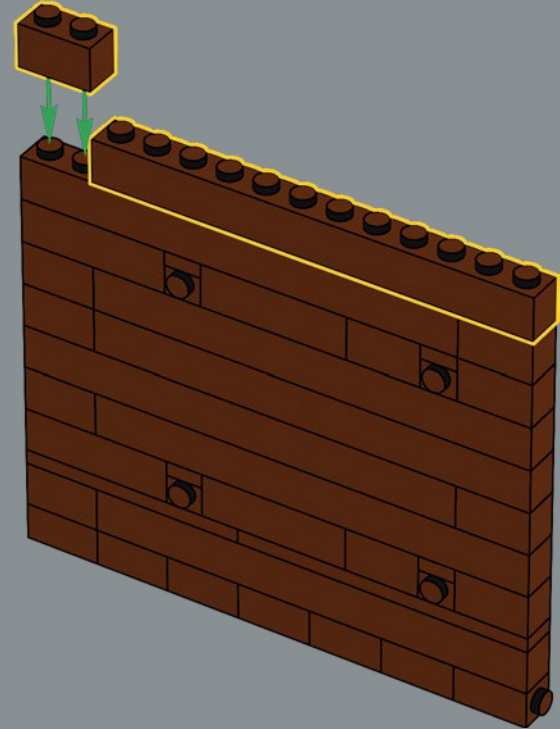

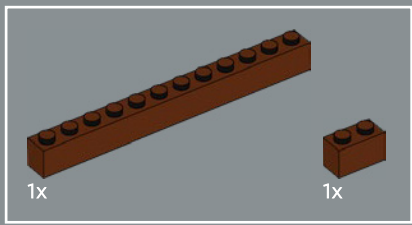

346

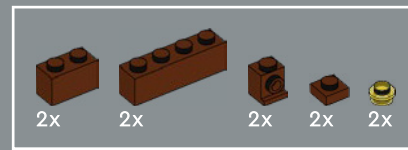
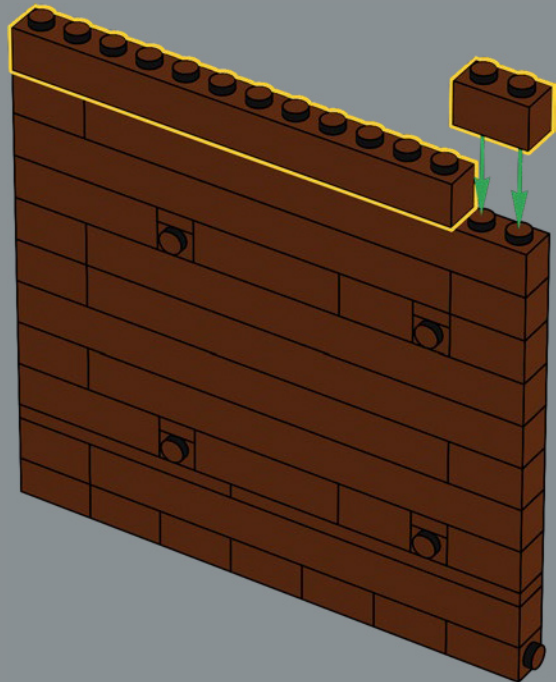

347

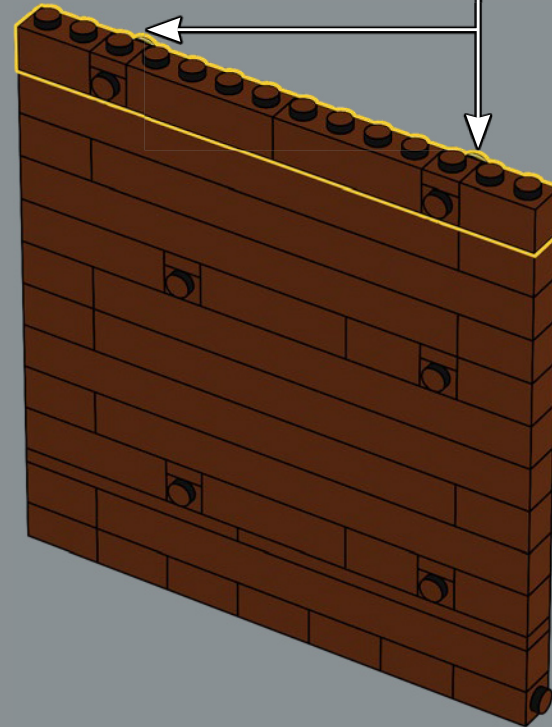
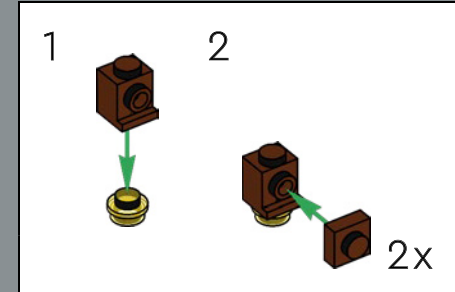

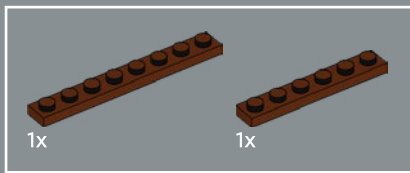

348

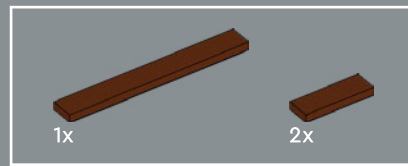
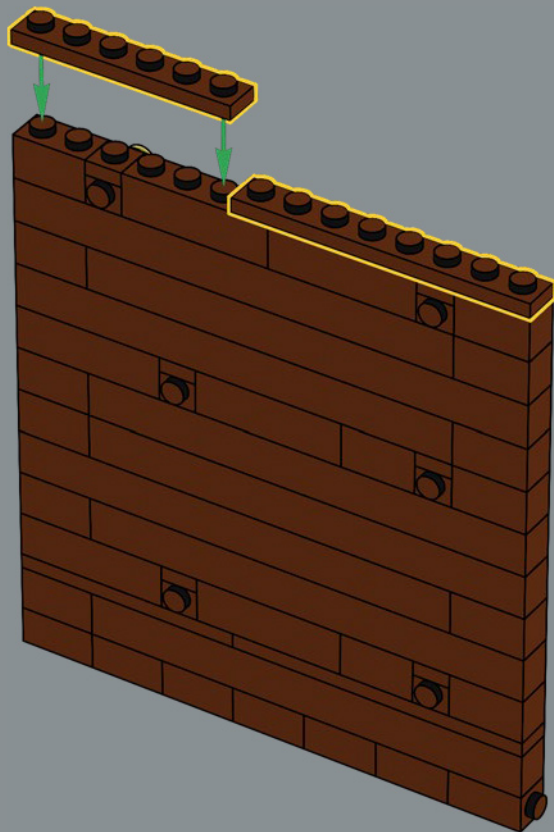

349

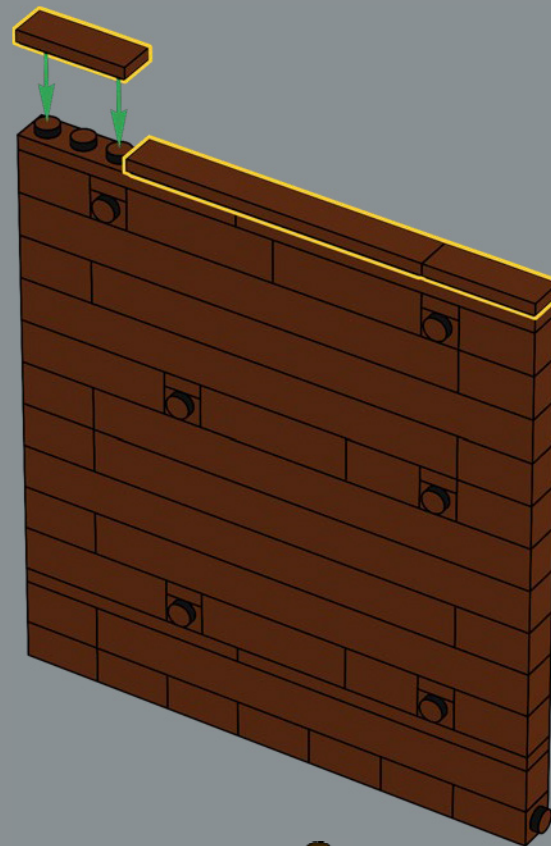

350

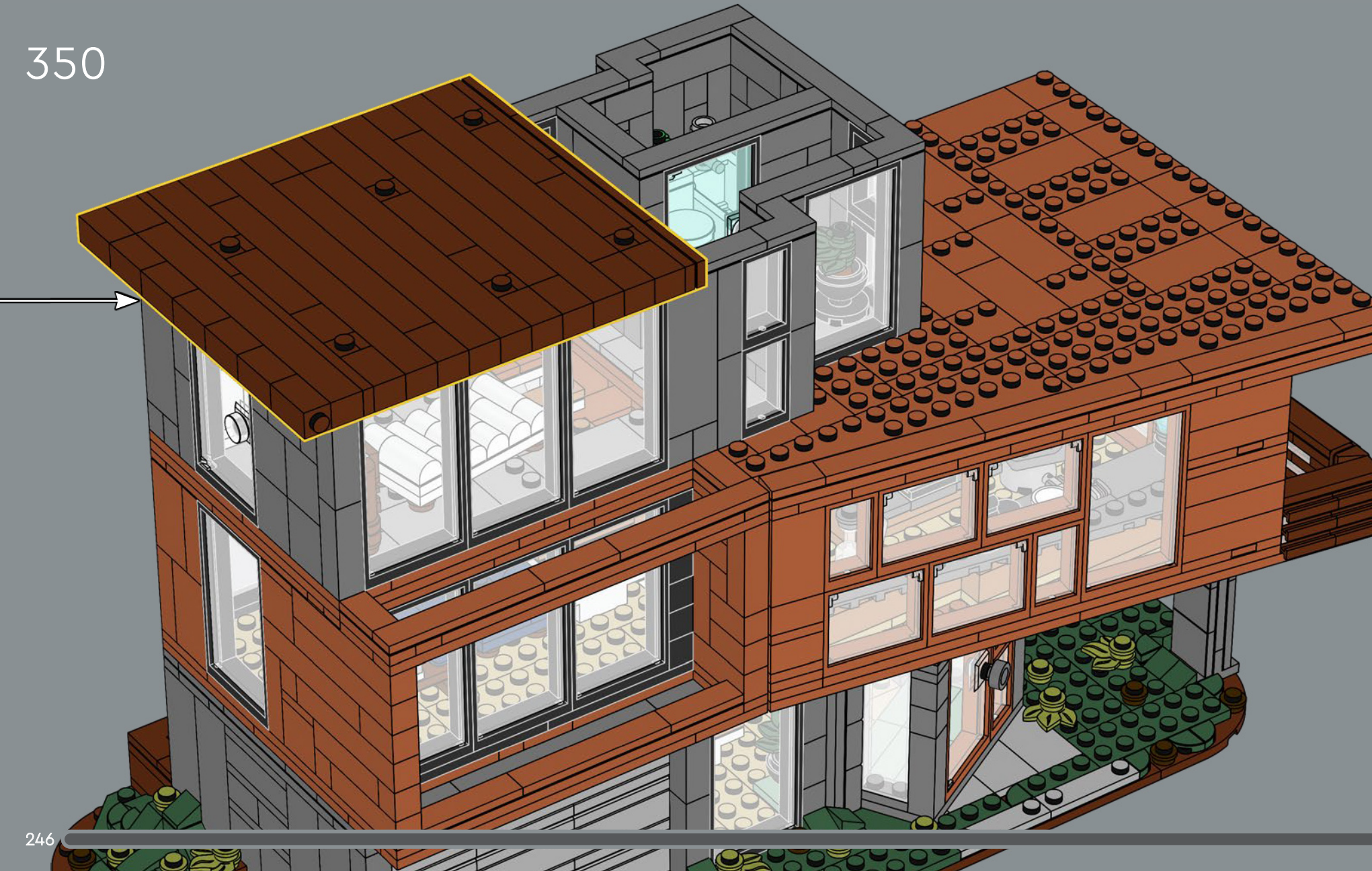

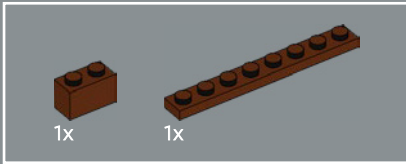
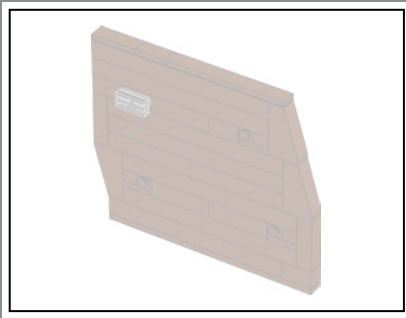

351

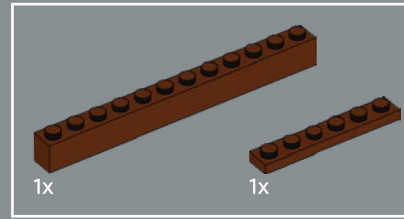
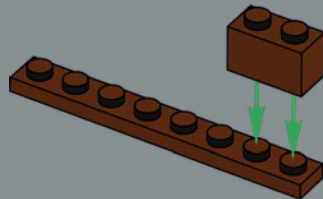

352

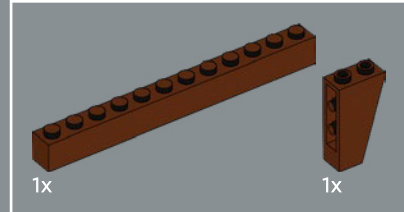
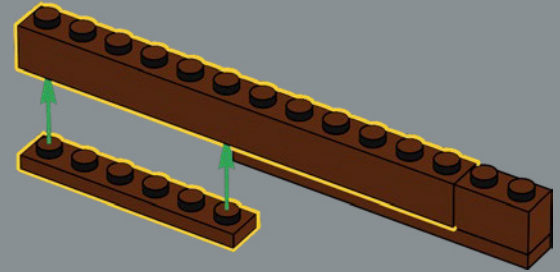

353

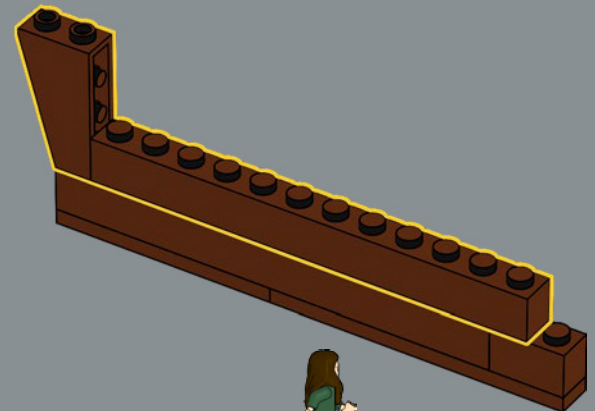

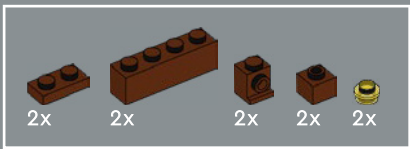

354

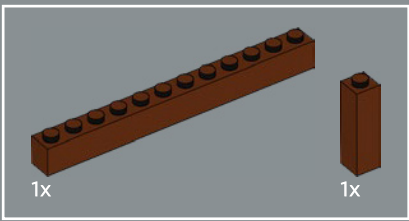
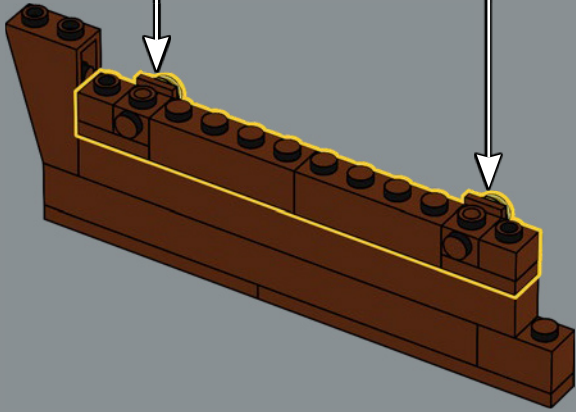
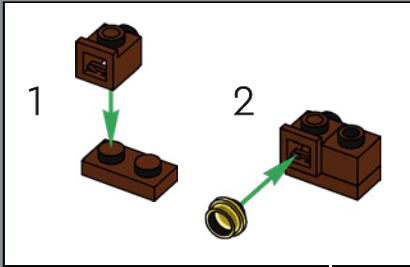
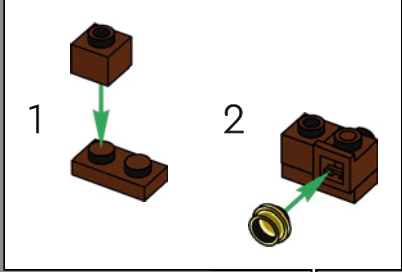

355

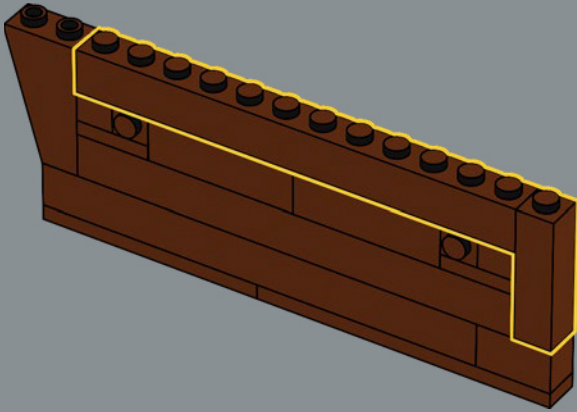

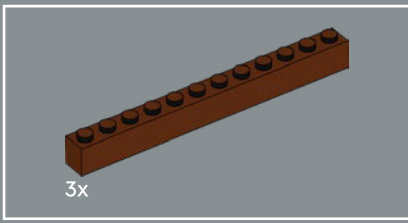

356

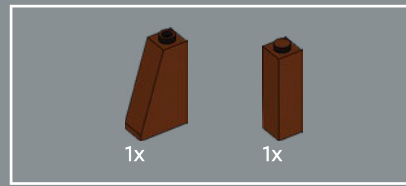
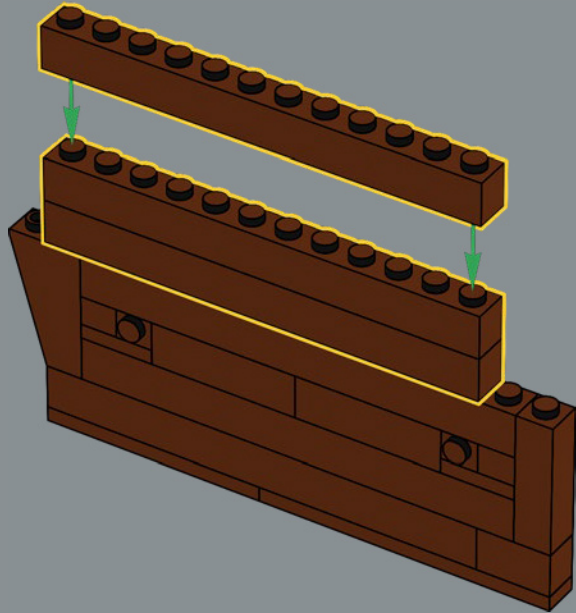

357

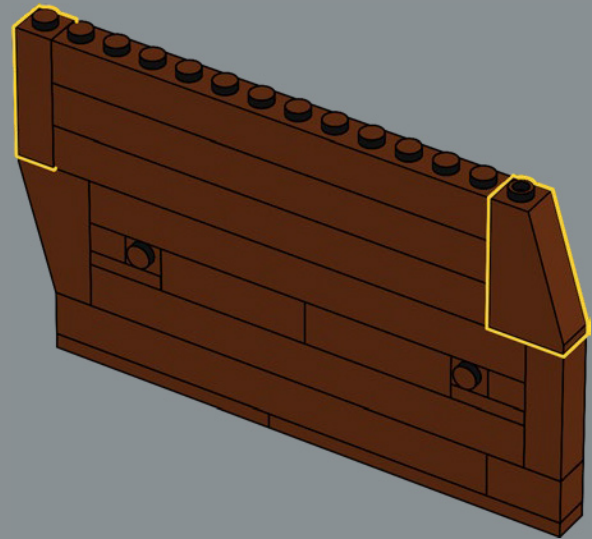

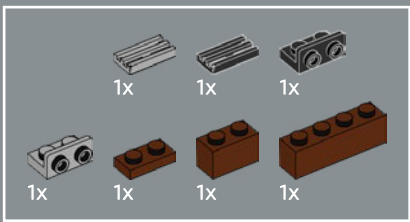

358

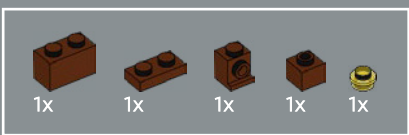
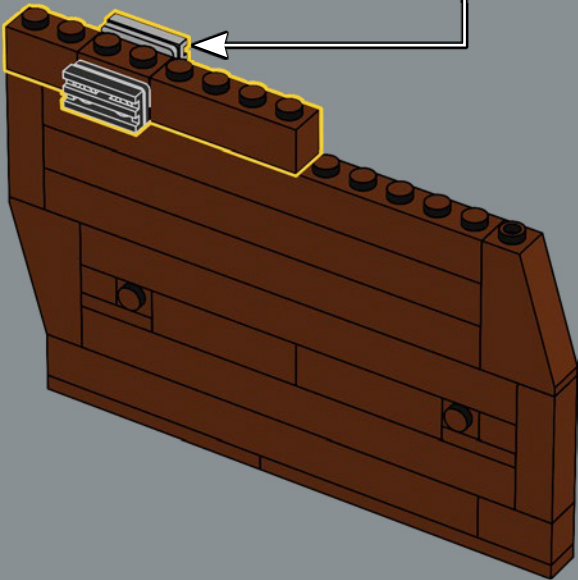
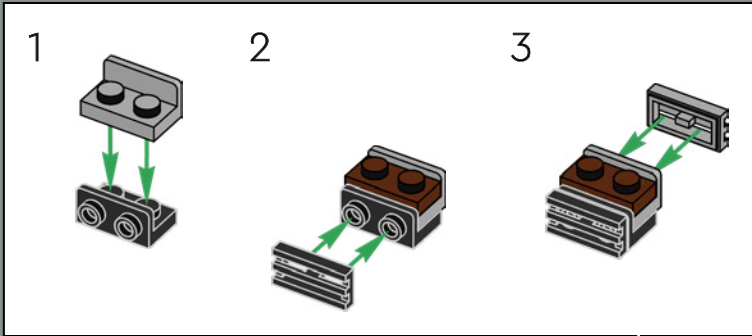

359

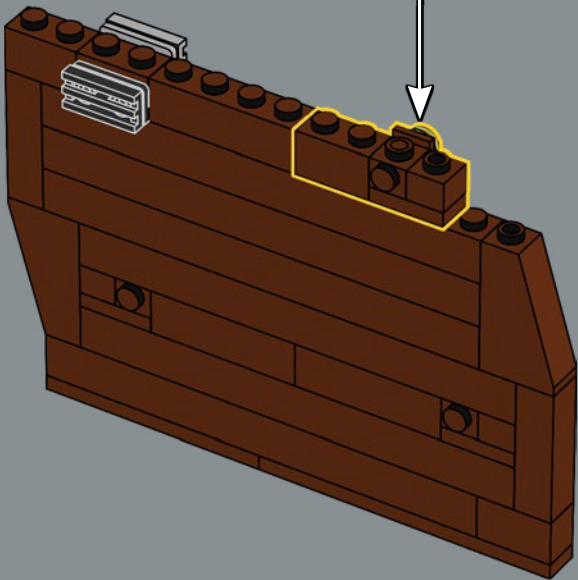
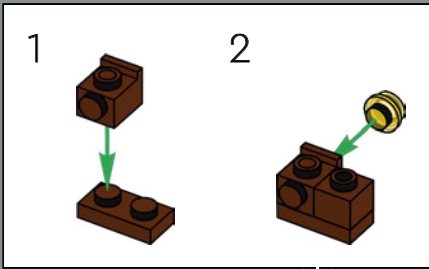

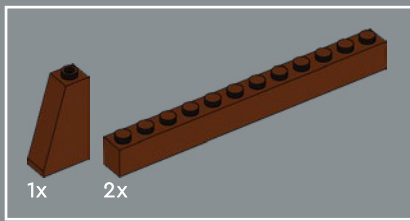

360

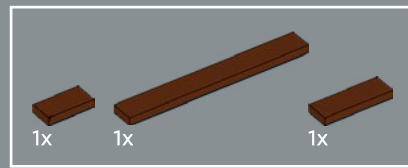
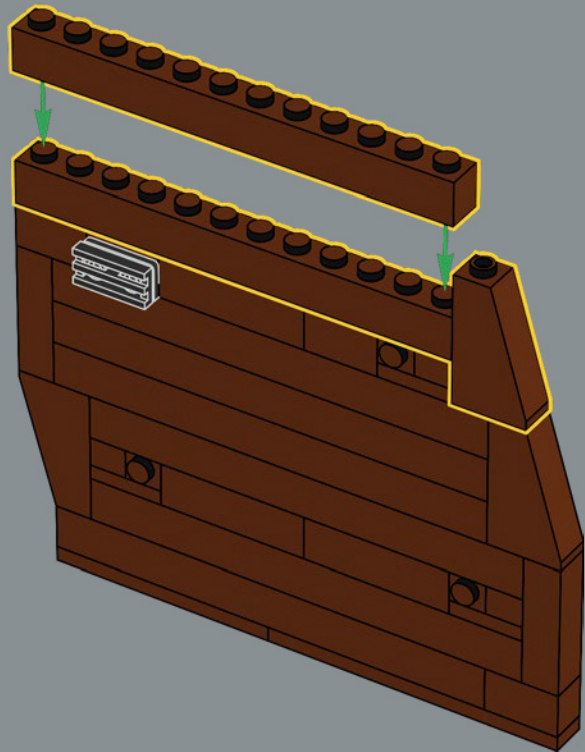

361

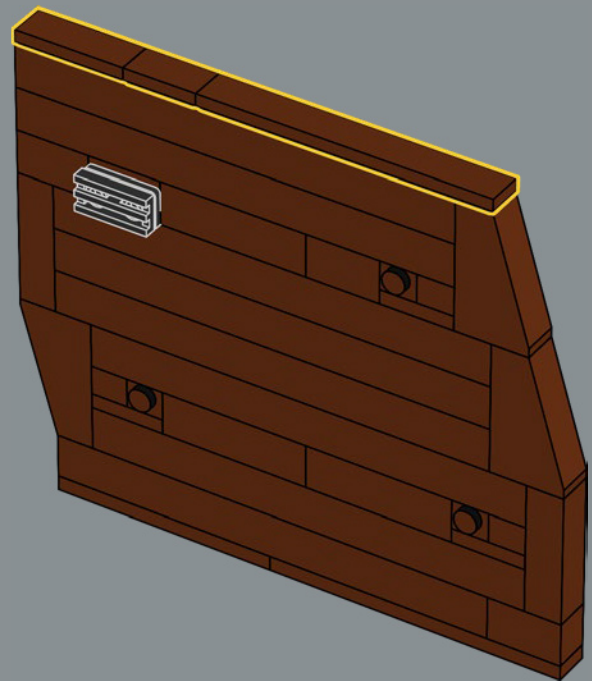

362

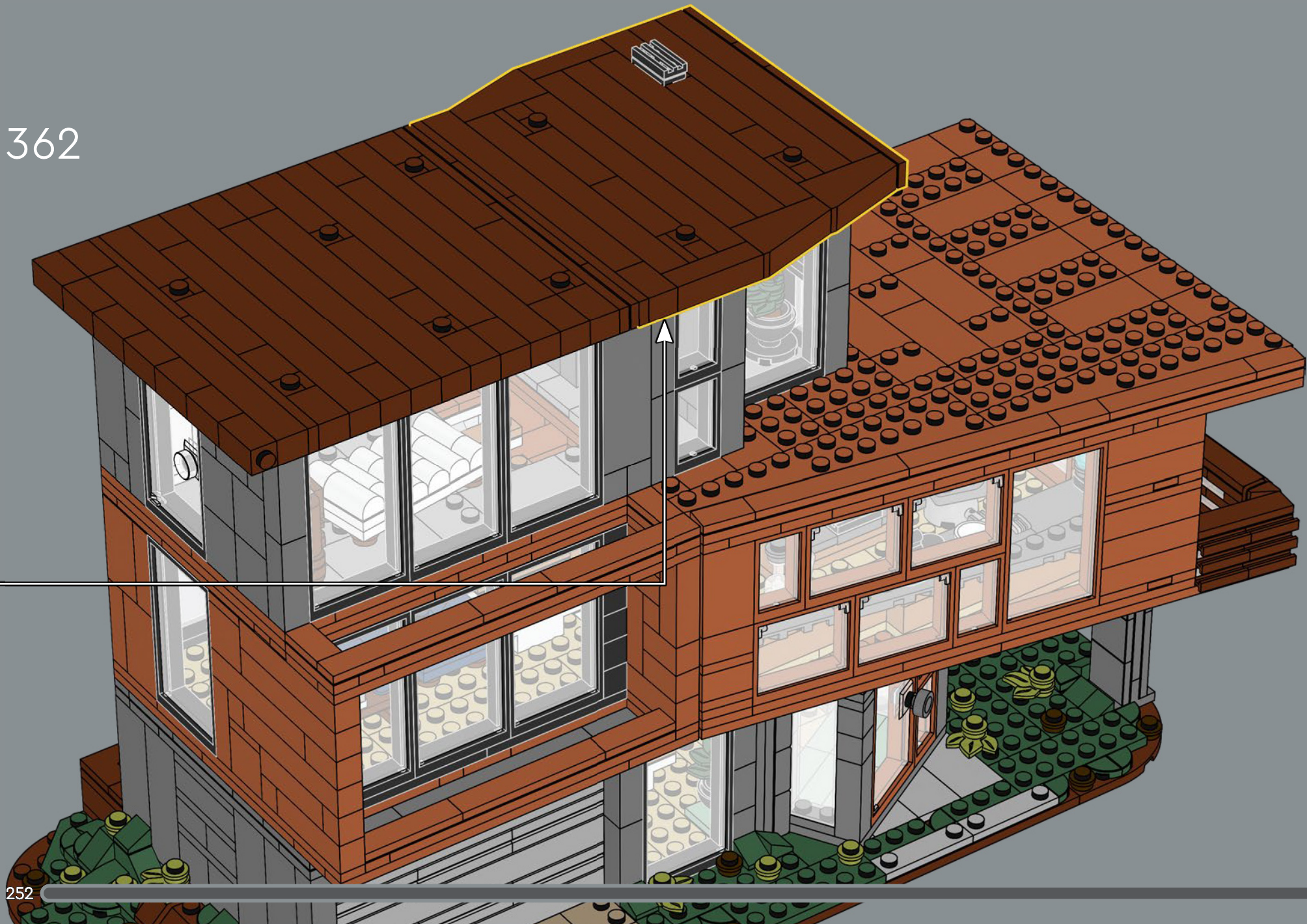

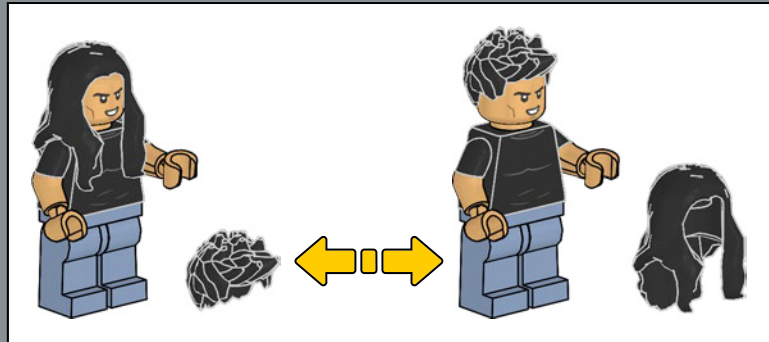
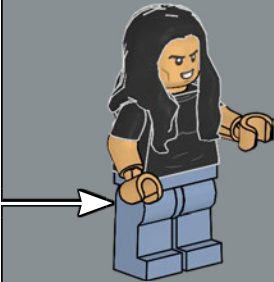
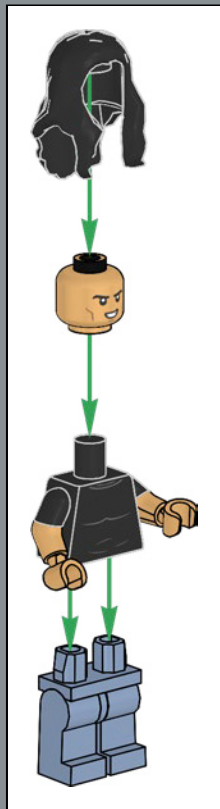

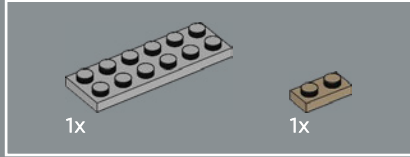
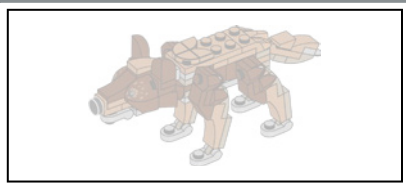

363

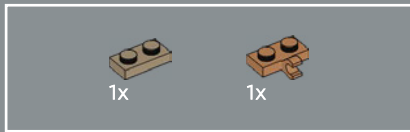
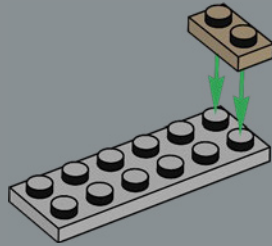

364

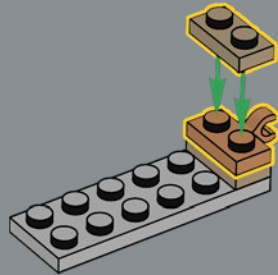

365

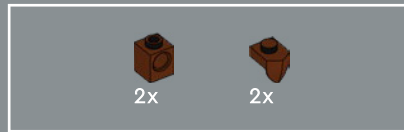
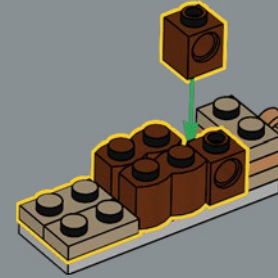

366

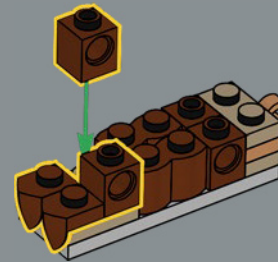



1x

371

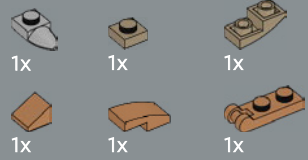
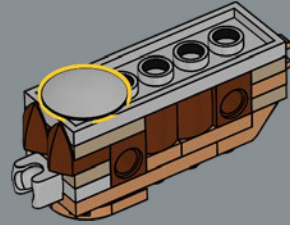

1x

1x

1x

1x

1x

1x

372

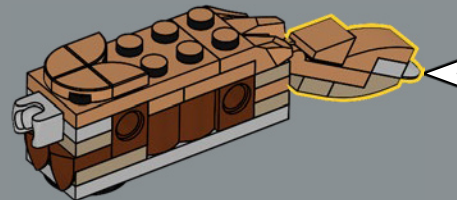
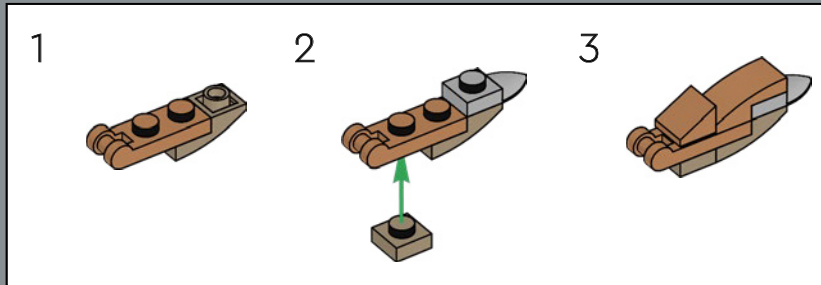

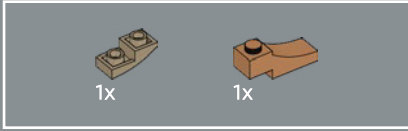
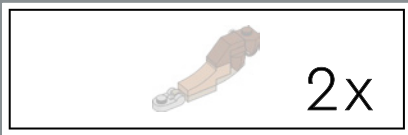

373

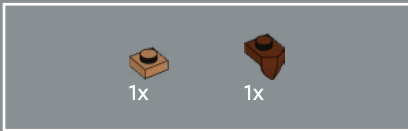
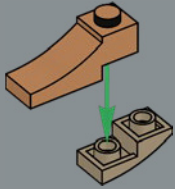

374

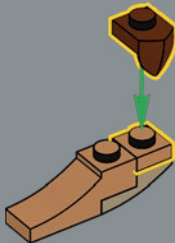

375

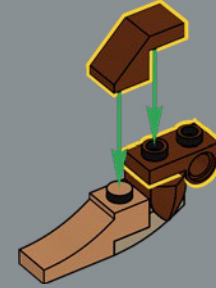

376

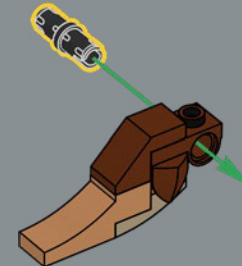



1x

377

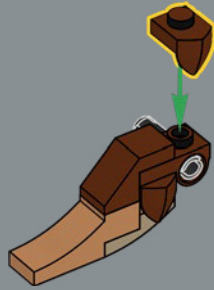

1x

1x

378

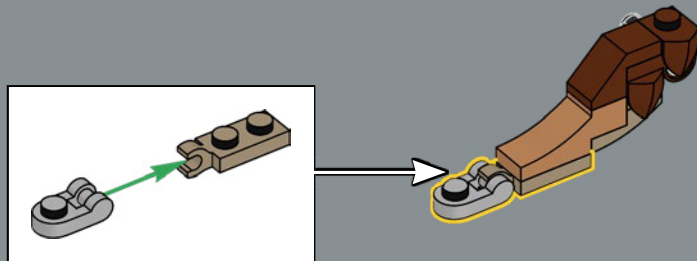

2x

379

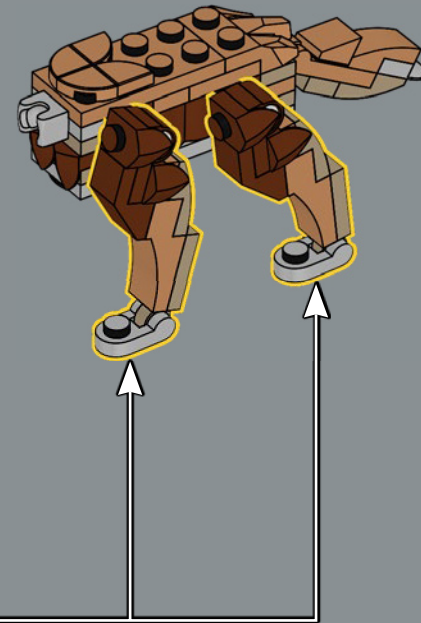

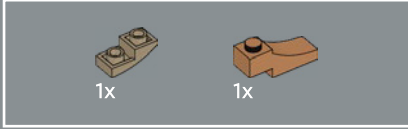
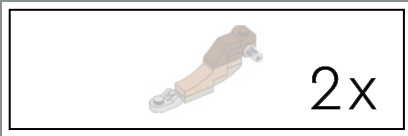

380

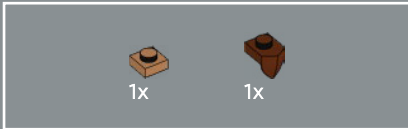
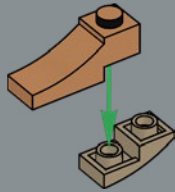

381

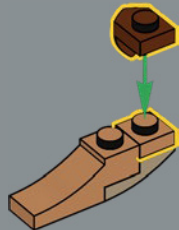

382

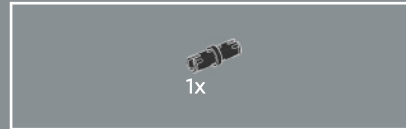
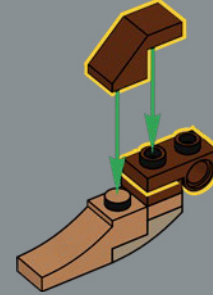

383

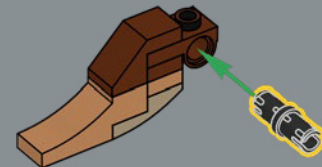



1x

384

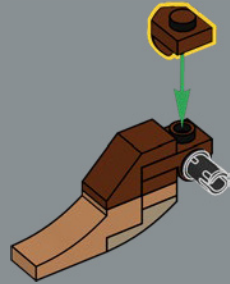

1x



1x

385

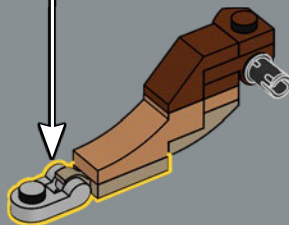
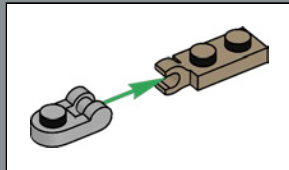

2x

386

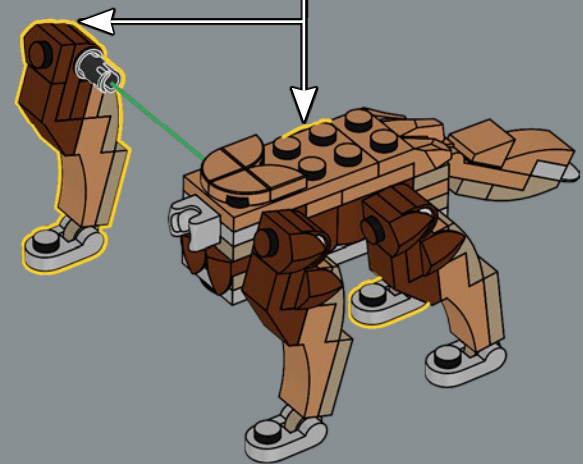

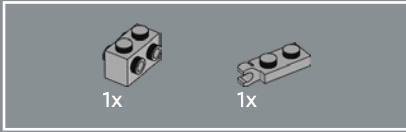

387

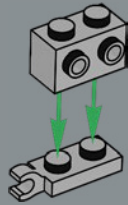

388

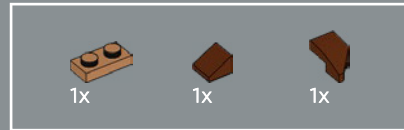
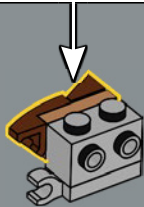
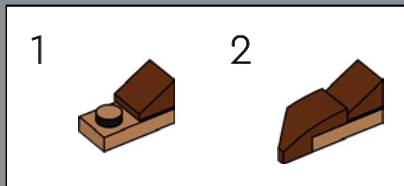

389

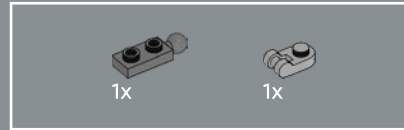
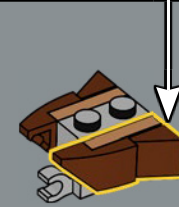
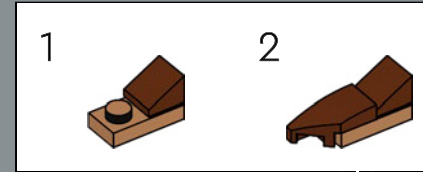

390

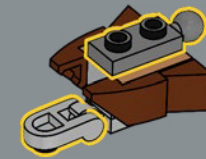

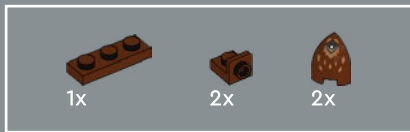

391

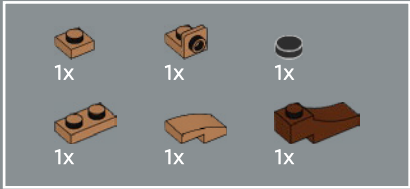
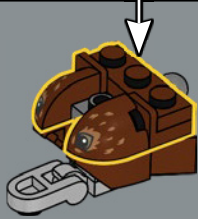
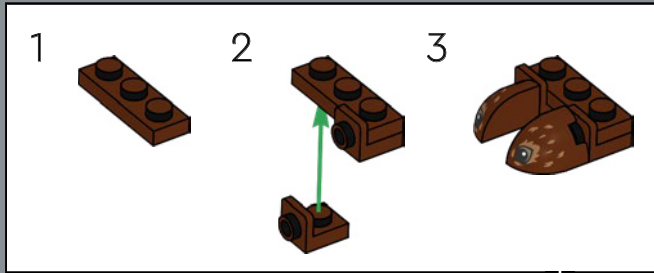

392

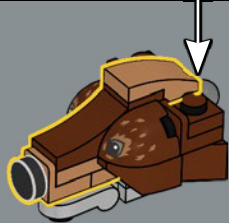
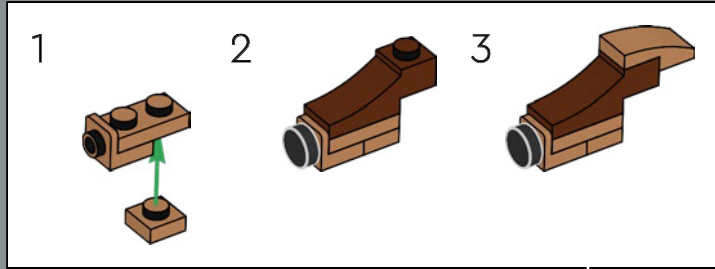

393

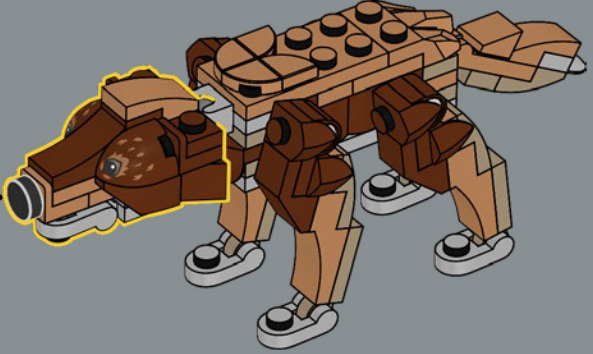

394

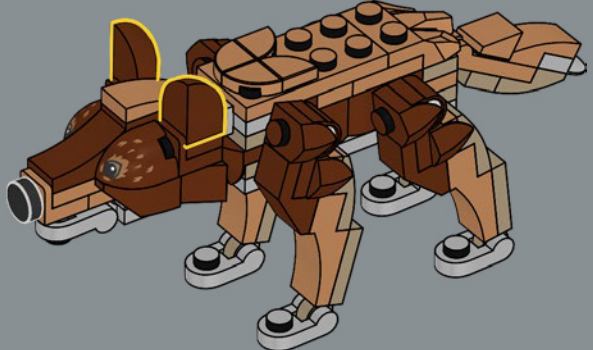

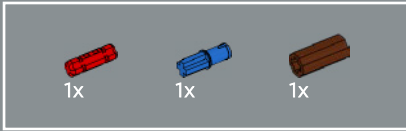
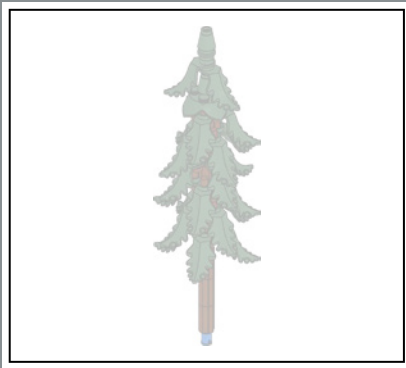

395

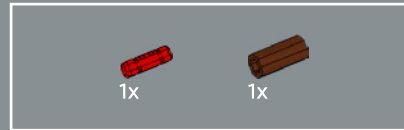

396

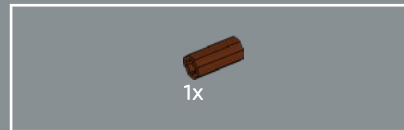

397



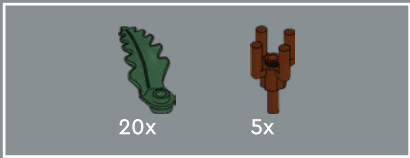

398

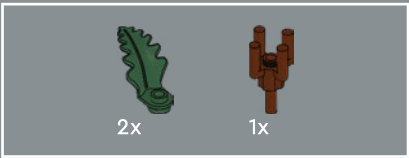
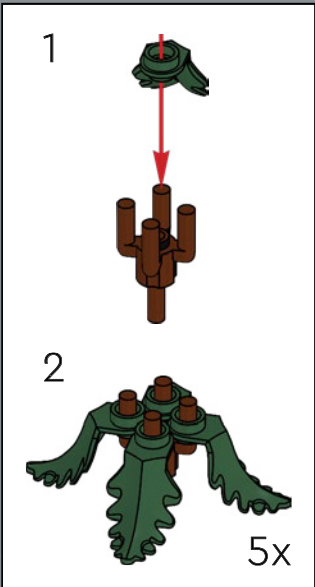

399

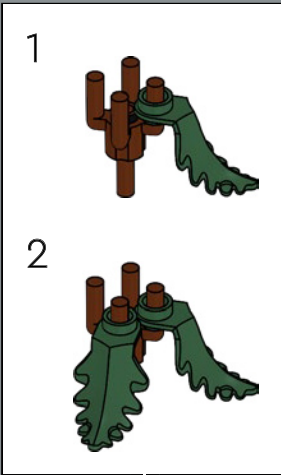



400

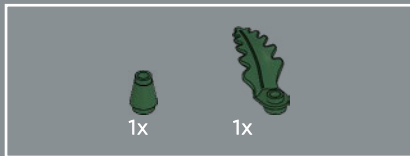
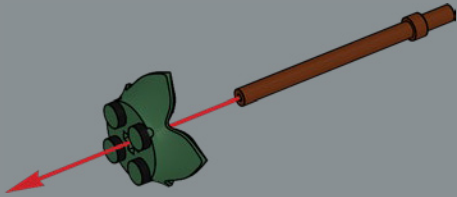

401

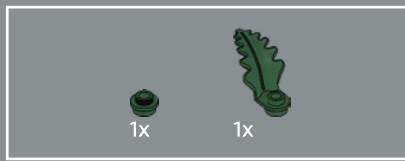
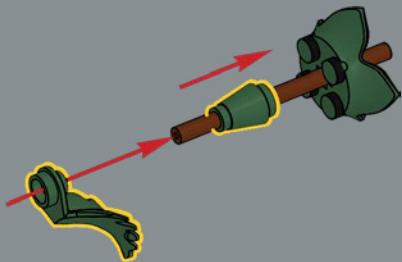

402

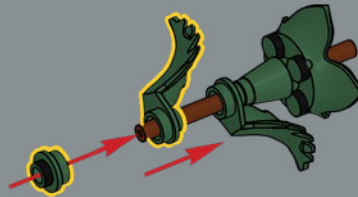

403

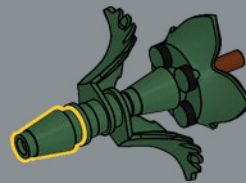

404



405



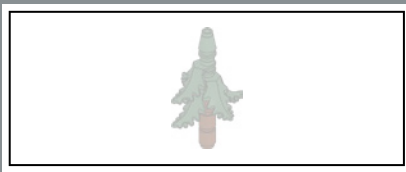

406



407

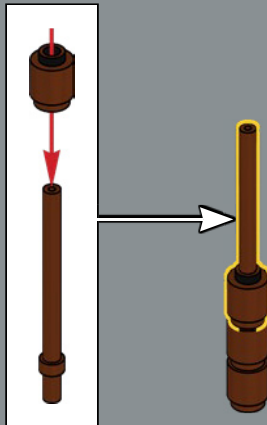

408





2x

409



1x



1x

410



1x

411



412

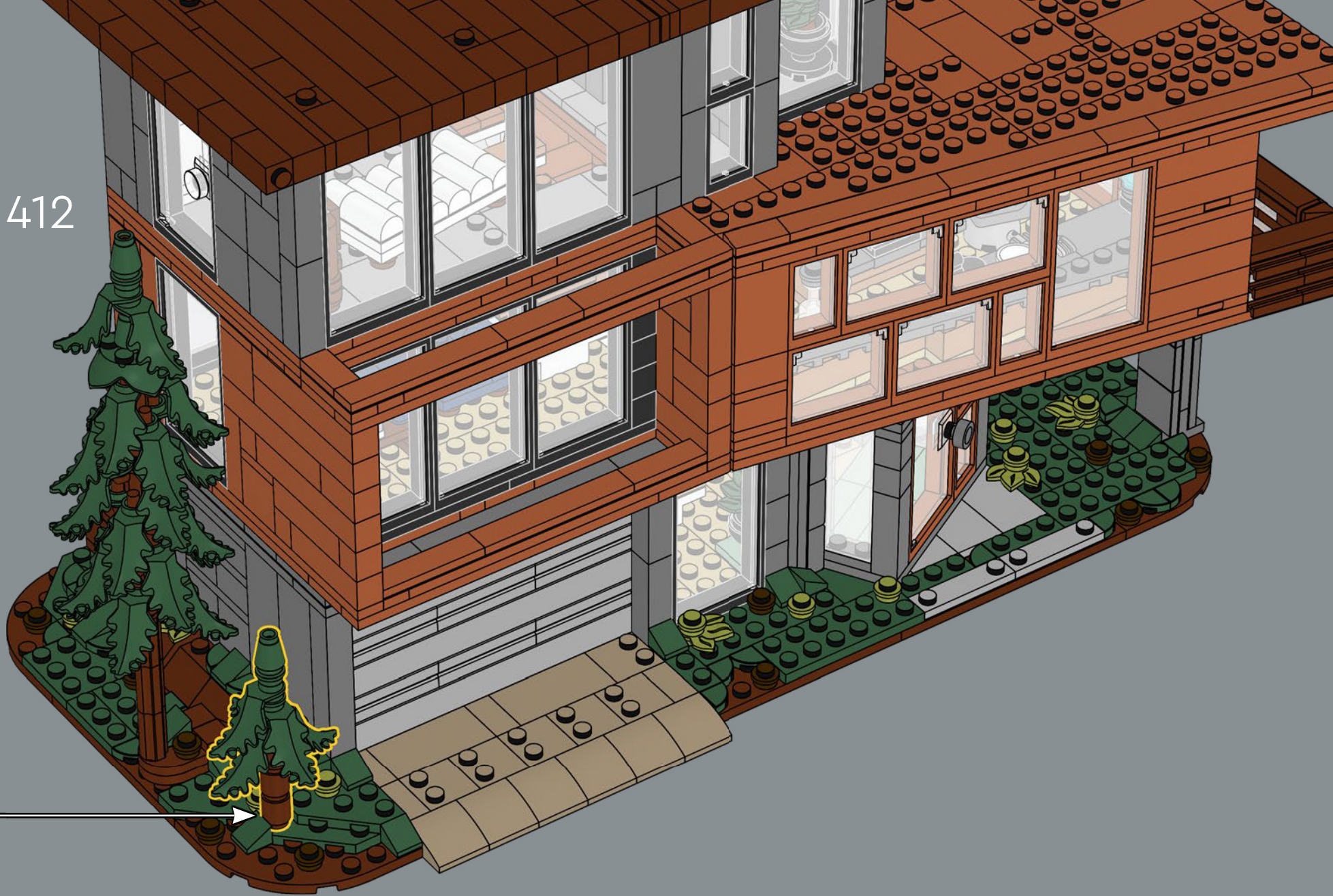

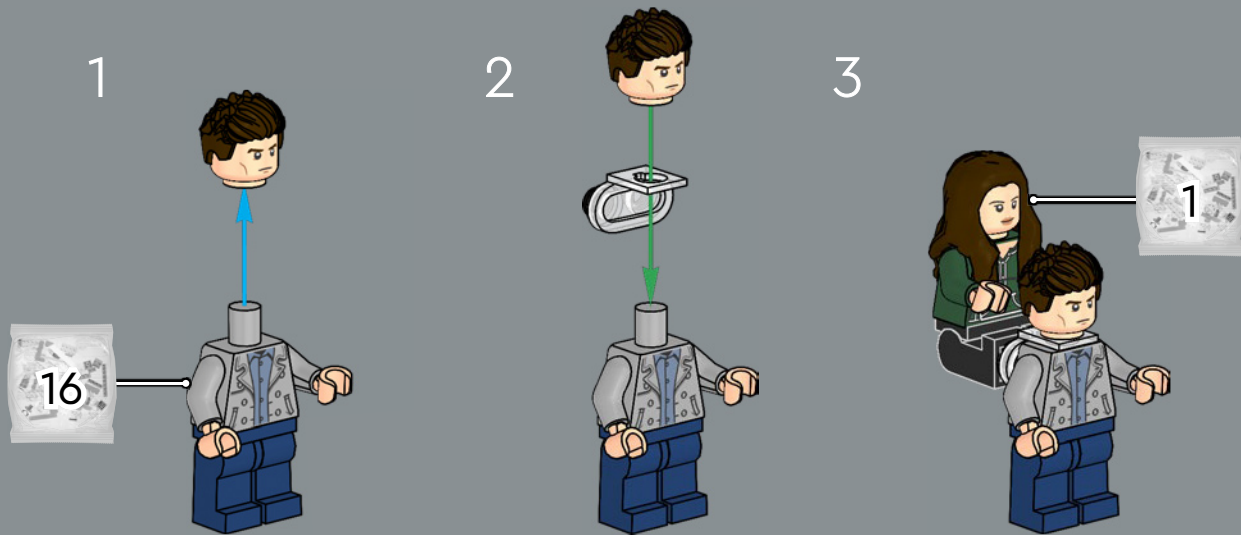



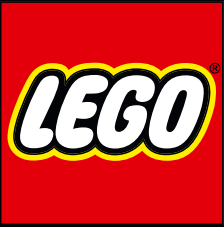

IDEAS

GATHER SUPPORT
OBTENEZ DE L'APPUI
OBTÉN APOYOS

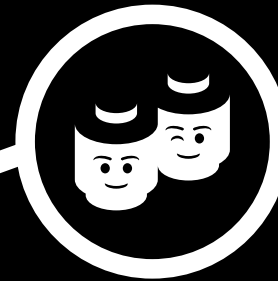

SHARE YOUR IDEA
PARTAGEZ VOTRE IDÉE
COMPARTE TU IDEA

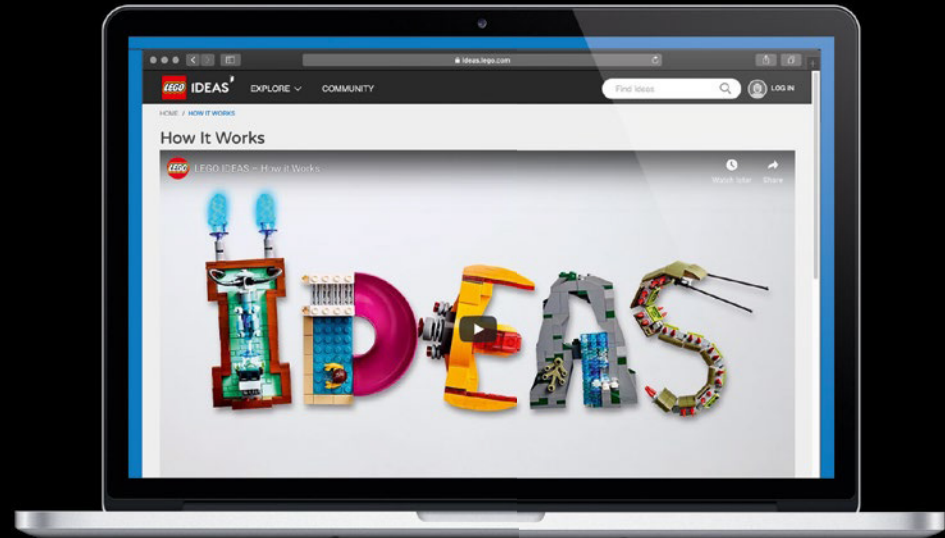
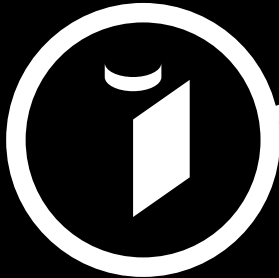

NEW LEGO® PRODUCT
NOUVEAU PRODUIT LEGO®
NUEVO PRODUCTO LEGO®

LEGO® REVIEW
EXAMEN LEGO®
REVISIÓN DE LEGO®



ideas.LEGO.com

2x 6206149
3x 614101
2x 302401
2x 6383985
6x 6258135
2x 6474222
1x 6044691
9x 306901
2x 6248490
4x 4113261
4x 302301
1x 300401
2x 4585458
3x 241201
6x 6450822
1x 6312480

2x 302201
4x 306801
2x 6126046
1x 300301
1x 362301
1x 6535730
1x 6089696
5x 6156667
2x 243101
1x 371001
1x 302001
1x 4560178
1x 366601
3x 379501

2x 6522741
3x 303401
2x 4125253
4x 4159553
1x 6535031
1x 6356348
2x 4140562
3x 4113917
4x 4114026
4x 6092587
5x 4185177
3x 6469454
2x 6131896
1x 4121921

6x 6257600
3x 6115031
1x 6122047
11x 4114309
3x 4124067
3x 4113993
12x 4113988
6x 6070501
1x 6093864
1x 306221
1x 6215539
4x 307021
2x 4190219

6x 6278441
11x 302421
1x 6397571
2x 6345637
2x 6435047
6x 6372478
2x 4142865
7x 302321
2x 6146217
4x 6184782
2x 6261351
2x 6393287
2x 6105976
4x 6219819
6x 242021
2x 366021

4x 362321
4x 6211447
2x 302121
4x 6170507
4x 243121
1x 301021
1x 302021
1x 4560179
4x 366621
1x 4616342
1x 6335578
1x 6432005
1x 4206482

8x 6135287
2x 6229130
3x 6228968
12x 6186012
17x 6397875
4x 6143431
4x 6254484
4x 6522737
2x 6490607
2x 6360214
4x 6188477
14x 6533058
26x 4570877
10x 4579659

1x 6228840
11x 4614158
22x 6315191
4x 6361813
4x 6533064
4x 6533065
24x 6394948
2x 6341393
4x 4615606
4x 6253417
1x 6187575

10x 6186007
8x 6263221
10x 6340118
3x 6359717
4x 6522738
15x 6223040
16x 6074892
3x 6074893
3x 6257603
5x 6522740
2x 6533074
10x 6058089
8x 4535928

23x 6253418
12x 6359696
4x 6000743
8x 6219673
1x 6264069
5x 6426644
2x 6310668
14x 6351327
19x 6536566
5x 6263971

1x 6514232
1x 6166107
4x 6514191
1x 6507876
2x 6513962
24x 6252258
1x 6510073
1x 6166106
24x 6514001
2x 6251285
19x 6256058
5x 6514119

4x 6514142
1x 6510175
2x 6514189
1x 6514118
2x 6514233
2x 6514018
1x 6514056
2x 6514234
1x 6510144
1x 6213778
1x 6254100
4x 4620077
1x 6138232

2x 4267425
2x 6142505
1x 6198156
1x 6057880
1x 4620993
1x 4549436
5x 6353065
5x 4528604
2x 4496699
4x 6354662
8x 6396392
6x 6093038
2x 6164288
1x 4255413
1x 4184108
1x 6056241

2x 4162916
6x 6384915
1x 4528981
8x 6092588
4x 6214810
1x 4205004
2x 6389696
1x 6135597
1x 6384913
1x 6027627
2x 6230571
3x 6446790
3x 6411591
17x 4504375
22x 6315608
6x 6400754

29x 6447541
3x 4255624
2x 6326011
3x 6055225
1x 6013102
1x 6426730
2x 4528778
5x 6328333
9x 6013975
1x 6535642
2x 6253285
10x 6253283
4x 6223913
7x 6184432
6x 6133896

1x 393724
2x 302224
4x 362324
1x 6335910
1x 6321194
2x 6284070
1x 6186675
3x 6538443
1x 6510216
3x 6477141
2x 300526
1x 6065496
3x 6228987
2x 307026
3x 6172383
1x 6335388
1x 6388352

1x 302426
1x 6508269
1x 6433936
1x 6134617
1x 6079896
7x 6210270
1x 6196548
3x 6102341
4x 6279875
1x 6070695
2x 6106280
2x 6195325
1x 6281993
2x 4644456
1x 452826
3x 9339

2x 241226
1x 4226995
4x 6288175
1x 6535029
10x 6468344
3x 6382697
3x 302326
2x 300426
1x 6146220
2x 6369578
1x 393726
1x 306926
1x 6020193
1x 6308883

1x 6428168
4x 6029208
4x 6482959
1x 306826
4x 302226
4x 6191630
1x 242026
3x 6211476
3x 4567436
1x 4124096
2x 6382491
1x 4558170
1x 6535691
1x 4227392
1x 6428167

1x 6162892
3x 302126
1x 371026
20x 6337273
1x 4515350
1x 6439175
1x 4560182
4x 6350415
2x 366626
1x 6469830
1x 6318582
2x 6001494

1x 6186826
14x 6202626
5x 4539090
2x 6214309
1x 6509398
1x 6422088
1x 6345847
12x 4216581
3x 421183
1x 6186673
3x 4529242
2x 6328180
2x 6452011
2x 6523171
2x 4504376
1x 6290397

4x 4620075
9x 4225469
2x 6177699
3x 6492305
7x 6201911
11x 4221744
3x 4211288
1x 6149677
2x 4211242
10x 6329114
2x 6238874
1x 6341553
6x 6483392
3x 6248944
1x 6290396
1x 6035291

2x 4211180
3x 4531751
6x 6248854
4x 6192310
9x 4211150
17x 4211149
2x 4270470
5x 4211151
8x 6092590
1x 4224243
2x 6433392
1x 4264755
19x 4645103
1x 6266770
1x 6430841

3x 4211202
1x 6221608
1x 6452321
4x 4211152
6x 6100769
1x 4211220
2x 6172636
1x 6463591
1x 6311441
9x 4211225
7x 4211194
1x 6307618
2x 6170468
3x 4221590

3x 4216945
2x 4585337
12x 6313736
4x 6368433
2x 4223729
16x 4222627
6x 4225715
1x 6343322
1x 4211503
2x 6308012
2x 4211389

1x 6061702
1x 4215513
1x 4211399
1x 6213644
2x 6248890
5x 6225246
1x 4278273
2x 6429052
1x 4657459
1x 6043656
1x 4211350
4x 6134378
1x 4211470
7x 4211398
4x 4211388
3x 6123809

1x 4211414
2x 6066097
1x 6004990
1x 6319336
1x 4494475
23x 6212077
2x 4211397
1x 6065824
2x 4211413
3x 4211429
1x 6535830
1x 6535590
1x 6168615
4x 4211396
3x 6171894

2x 4211445
9x 6314891
2x 6257593
6x 4211356
10x 4560183
3x 6079461
3x 4211438
1x 4211452
1x 4211462
3x 4211522
3x 4211360
5x 4211402

3x 6452523
11x 4210633
4x 6284596
4x 6271752
31x 6396489
33x 4211098
9x 4210719
3x 6228923
3x 4210848
2x 6344022
1x 4210690
3x 6448323
3x 6448325

1x 6296892
4x 4567887
1x 6055313
14x 4211063
11x 4210978
6x 4211088
7x 4211052
6x 6230233
19x 4211075
1x 6250018
1x 6123814
4x 6013082
2x 4210635
2x 4211055
2x 4211094

1x
6363148

1x
6361354

1x
6236213

2x
4619636

1x
6151664

2x
4655256

1x
6251854

2x
6251841

20x
6258990

7x
6398008

1x
6523160

1x
6523162

1x
6523164

1x
6523158

1x
6523156

1x
6060800

1x
6186672

13x
6315780

1x
6537328

1x
6240208

1x
6223143

19x
6215606

1x
6167690

4x
6248536

1x
6378362

2x
6057986

9x
6422082

2x
6177146

1x
6324205

6x
6218360

2x
6356566

1x
6313132

3x
4569382

1x
6226646

7x
6021997

1x
6372265

1x
6056383

1x
6435640

1x
6102990

1x
6177535

2x
6528998

1x
6102994

1x
6167699

4x
6433732

2x
6187006

5x
6167700

15x
6257605

2x
6093494

2x
6218359

2x
6099341

2x
6350413

1x
6313600

5x
6474197

4x
6247784

2x
4211109

2x
4524930

10x
4568734

4x
4211133

1x
4211104

1x
6535678

1x
4211043

11x
4211001

5x
4211053

1x
4210725

3x
6257592

9x
4211103

2x
6416526

3x
4211065

3x
4560184

1x
4211100

2x
4211002

12x
4211008

4x
4210998

1x
4210997

1x
4211061

1x
4210798

1x
6523166

1x
6523168



 [LEGO.com/service](https://www.LEGO.com/service)



YOU COULD WIN



YOU COULD WIN

Your feedback will help shape the future development of this product series.

Visit:

DU KÖNNTEST GEWINNEN

Dein Feedback trägt zur Weiterentwicklung dieser Produktreihe bei.

Geh auf:

VOUS POURRIEZ GAGNER

Vos commentaires nous aideront à concevoir les futurs produits de cette gamme.

Visitez :

POTRESTI VINCERE TU

La tua opinione ci aiuterà a migliorare la creazione futura di questa linea di prodotti.

Visita:

PUEDES GANAR

Tu opinión contribuirá al futuro de esta serie de productos.

Visita:

轻松获奖

您的反馈将有助于我们在今后改进本产品系列。

请访问:

LEGO.com/productfeedback

You also have the chance to win a LEGO® set.

Terms and conditions apply.*

Außerdem hast du die Chance, ein LEGO® Set zu gewinnen.

Es gelten die Teilnahmebedingungen.*

Vous pourriez également gagner un ensemble LEGO®.

Des conditions s'appliquent.*

Hai anche la possibilità di vincere un set LEGO®.

Termini e condizioni sono applicabili.*

También tienes la oportunidad de ganar un set LEGO®.

Aplican términos y condiciones.*

您还有机会赢取乐高®套装。

条款和条件适用。*

*LEGO.com/productfeedback-terms

