



10350



Booklet available in English  
Livret disponible en français  
Folleto disponible en español



LEGO® Builder





## WE'RE MAKING OUR PACKAGING MORE SUSTAINABLE

We're transitioning from single-use plastic to paper-based packaging. As we progress, you may find a mix of paper and plastic in our boxes.

## NOUS RENDONS NOS EMBALLAGES PLUS DURABLES

Nous passons des emballages en plastique à usage unique aux emballages à base de papier. Durant la transition, vous pourriez trouver un mélange de papier et de plastique dans nos boîtes.

## QUEREMOS HACER MÁS SUSTENTABLES NUESTROS MATERIALES DE EMBALAJE

Estamos cambiando las bolsas de plástico desechables por bolsas con base de papel. Conforme avanzamos en este propósito, puedes encontrar una mezcla de papel y de plástico en nuestras cajas.

[LEGO.com/sustainable-packaging](https://LEGO.com/sustainable-packaging)



# BUILDER



Apple and the Apple logo are trademarks of Apple Inc., registered in the U.S. and other countries and regions. App Store is a service mark of Apple Inc. Google Play and the Google Play logo are trademarks of Google LLC. Tencent and the Tencent logo are trademarks of Tencent Inc.

Q [LEGO.com/devicecheck](https://www.lego.com/devicecheck)



Q LEGO® Builder



FRANÇOIS ZAPF  
LEGO® Icons Designer  
Concepteur LEGO® Icons  
Diseñador de LEGO® Icons

## Timeless Tudor charm

Welcome to a modular corner with a strong, undeniably British accent! This is the first time we are celebrating Tudor architecture in the Modular Buildings Collection. This gave us a chance to create new, interesting building experiences, specifically for the upper section with its steeply pitched roof, prominent cross gables and half-timbered jettied top floor. We hope you will have as much fun building it as we had designing it.

## Un charme intemporel

Bienvenue dans un bâtiment en coin modulaire à l'accent britannique indéniable ! C'est la première fois que nous célébrons le style Tudor dans la collection des bâtiments modulaires. Cela nous a donné l'occasion de créer de nouvelles expériences de construction intéressantes, en particulier pour la partie supérieure avec le toit à forte pente, les pignons croisés en déport et l'étage supérieur à colombages. Nous espérons que vous aurez autant de plaisir à construire le modèle que nous en avons eu à le concevoir.

## El encanto eterno del estilo tudor

¡Te damos la bienvenida a una esquina con un marcado y auténtico acento británico! Es la primera vez que rendimos tributo a la arquitectura tudor en nuestra colección Modular Buildings. Esta fue una gran oportunidad para crear nuevas e interesantes formas de construcción, especialmente para la parte más alta, con su techo inclinado, sus llamativos frontones entrecruzados y su piso superior con estructura de madera. Esperamos que te diviertas tanto construyendo el set como nosotros nos divertimos diseñándolo.





## Make yourself at home

If these walls could talk! Inside and out, the Tudor Corner is buzzing with activity, as it might have since it was built five centuries ago. Times have ushered in more modern amenities, but the atmosphere is saturated with a rich history. Stories of everyday events and local legends are still told over delicious meals in the coziest venue in town, the Old Guarded Inn. A deep affection for craftsmanship and traditional British culture are felt in the finest haberdashery notions. The clockmaker proudly repairs precious family heirlooms. The tenant upstairs always has time for visitors (and room for more cats). Yes, this place truly feels like home for all who walk through the doors. (Or climb down the chimney!)



## Faites comme chez vous

Si ces murs pouvaient parler ! À l'intérieur comme à l'extérieur, la bâtisse Tudor en coin est aussi animée qu'elle devait l'être à l'époque de sa construction, il y a cinq siècles. La modernité s'est installée au fil du temps, mais l'atmosphère reste imprégnée d'un riche passé. Des histoires du quotidien et des légendes locales sont toujours racontées autour de délicieux repas dans le lieu le plus accueillant de la ville, la vieille auberge. Les articles de mercerie les plus raffinés témoignent d'une profonde affection pour l'artisanat et la culture britannique traditionnelle. L'horloger répare avec fierté les précieux trésors familiaux. La locataire à l'étage a toujours du temps à consacrer aux visiteurs (et de la place pour d'autres chats). Oui, cet endroit est un véritable havre de paix pour tous ceux qui franchissent les portes (ou qui descendent par la cheminée !).



## Te sientes como en casa

¡Si estas paredes pudieran hablar...! Por dentro y por fuera, la Esquina Tudor está siempre llena de vida, como ha sido desde su construcción hace cinco siglos. La modernidad ha traído consigo nuevas comodidades, pero el lugar sigue impregnado de una historia fascinante. Aún se relatan historias de acontecimientos cotidianos y leyendas locales mientras se disfrutaban exquisitos platillos en el establecimiento más acogedor de la ciudad, el Old Guarded Inn. El profundo cariño por las tradiciones artesanales y culturales británicas se refleja en las mejores piezas de mercería. El relojero repara con orgullo valiosas reliquias familiares. La inquilina del piso superior siempre tiene tiempo para las visitas (¡y espacio para más gatos!). En efecto, este lugar realmente se siente como un hogar para todos quienes cruzan sus puertas. (¡O bajan por la chimenea!).



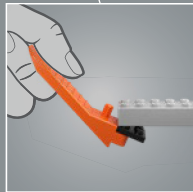
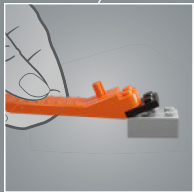
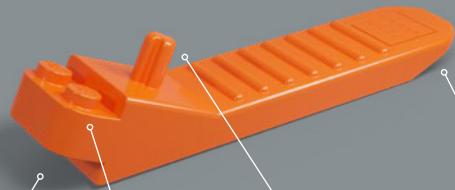



The weather forecast calls for rain! Fortunately, this lady is well prepared. Her hat fashion style was influenced by passengers on the LEGO® Ideas The Orient Express Train (21344).

Les prévisions météorologiques annoncent de la pluie ! Heureusement, cette dame est bien préparée. Son chapeau est inspiré du style des passagers du train Orient-Express LEGO® Ideas (21344).

¡El pronóstico del tiempo anuncia lluvia! Por suerte, esta señora va bien preparada. Su elegante sombrero está inspirado en los pasajeros del Expreso de Oriente LEGO® Ideas (21344).

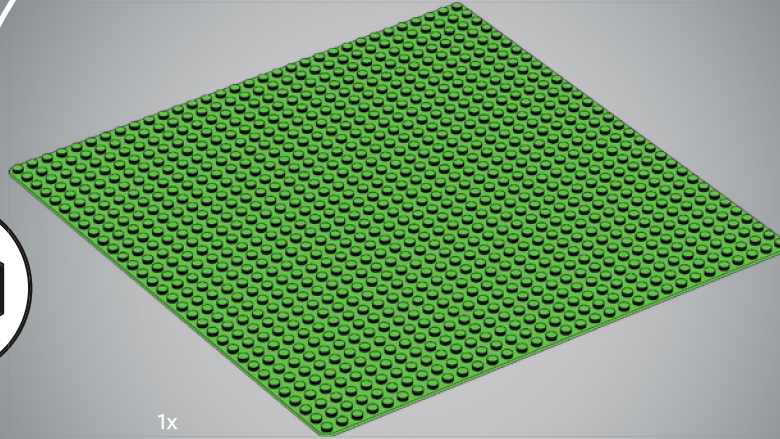

1x

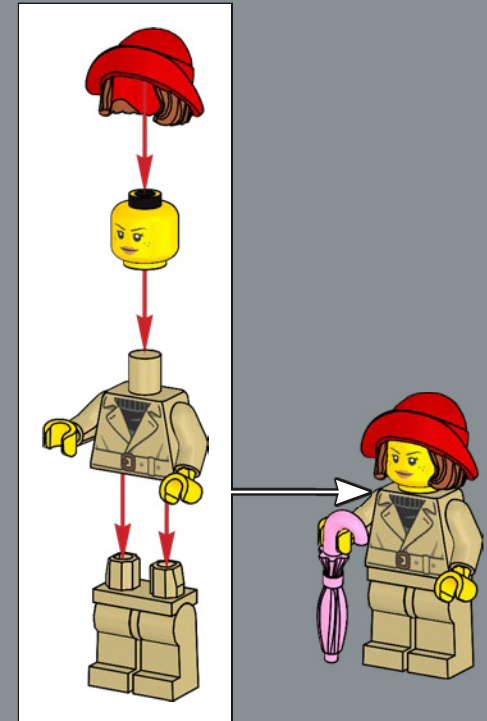

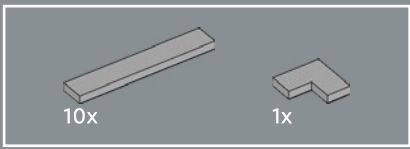

1

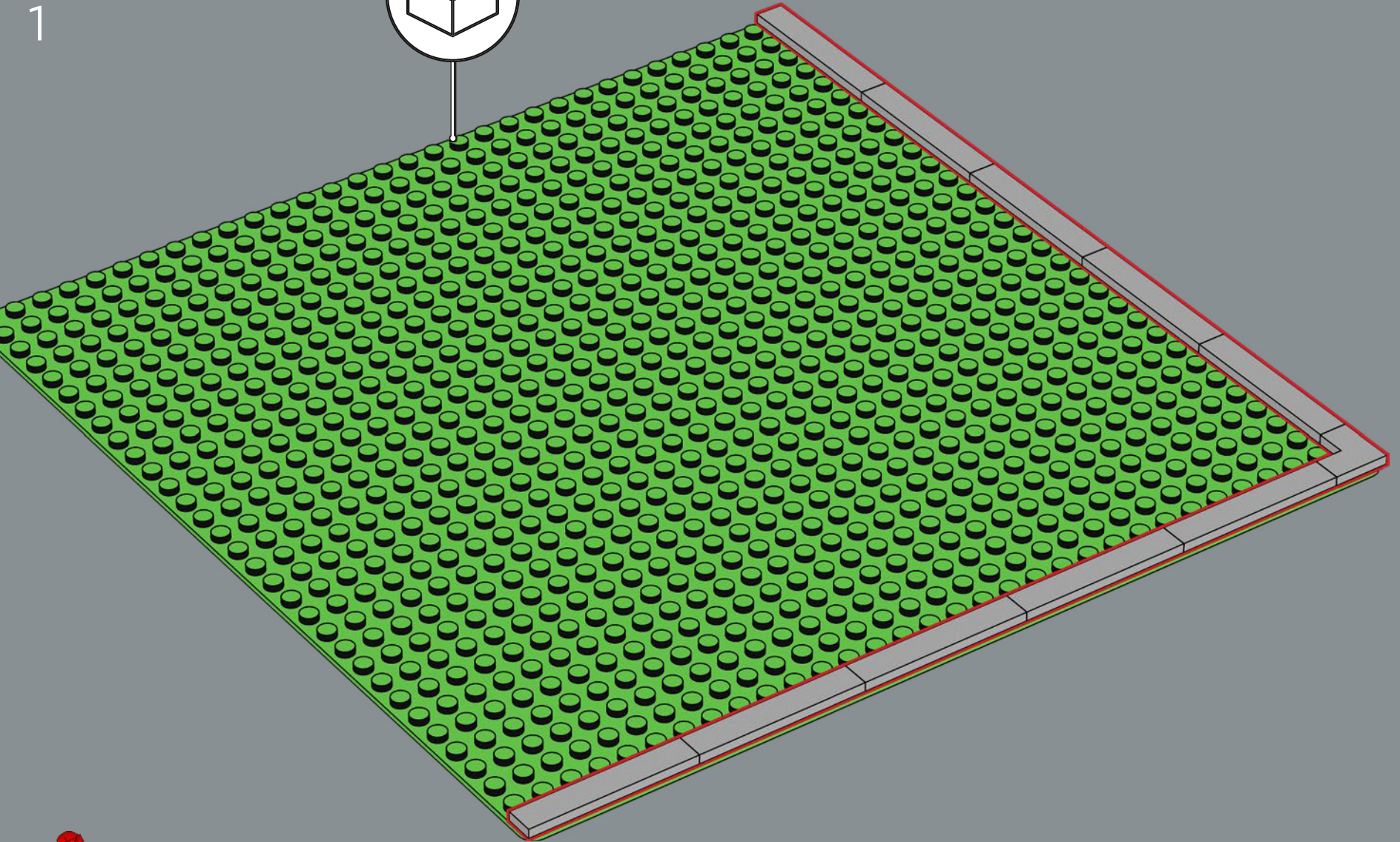
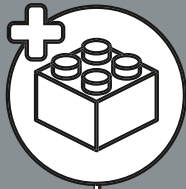



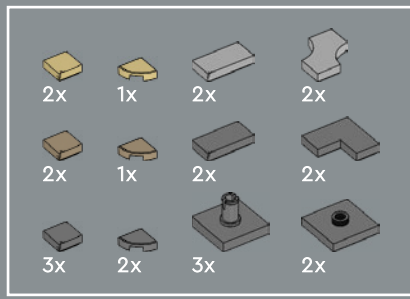

2

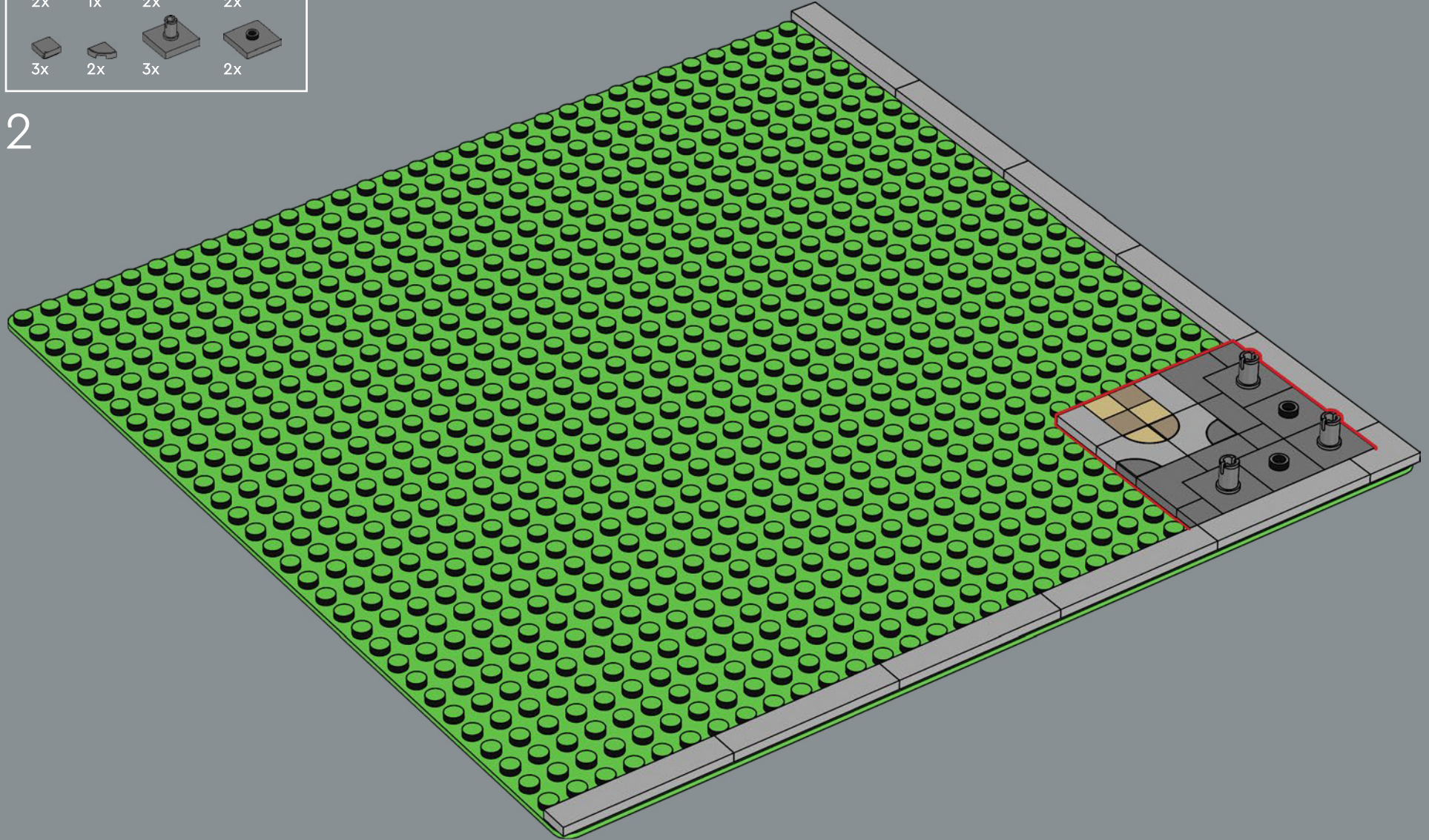

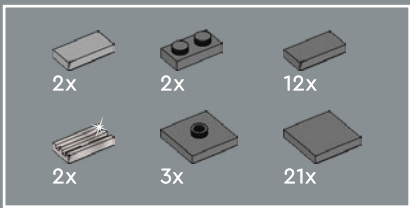

3

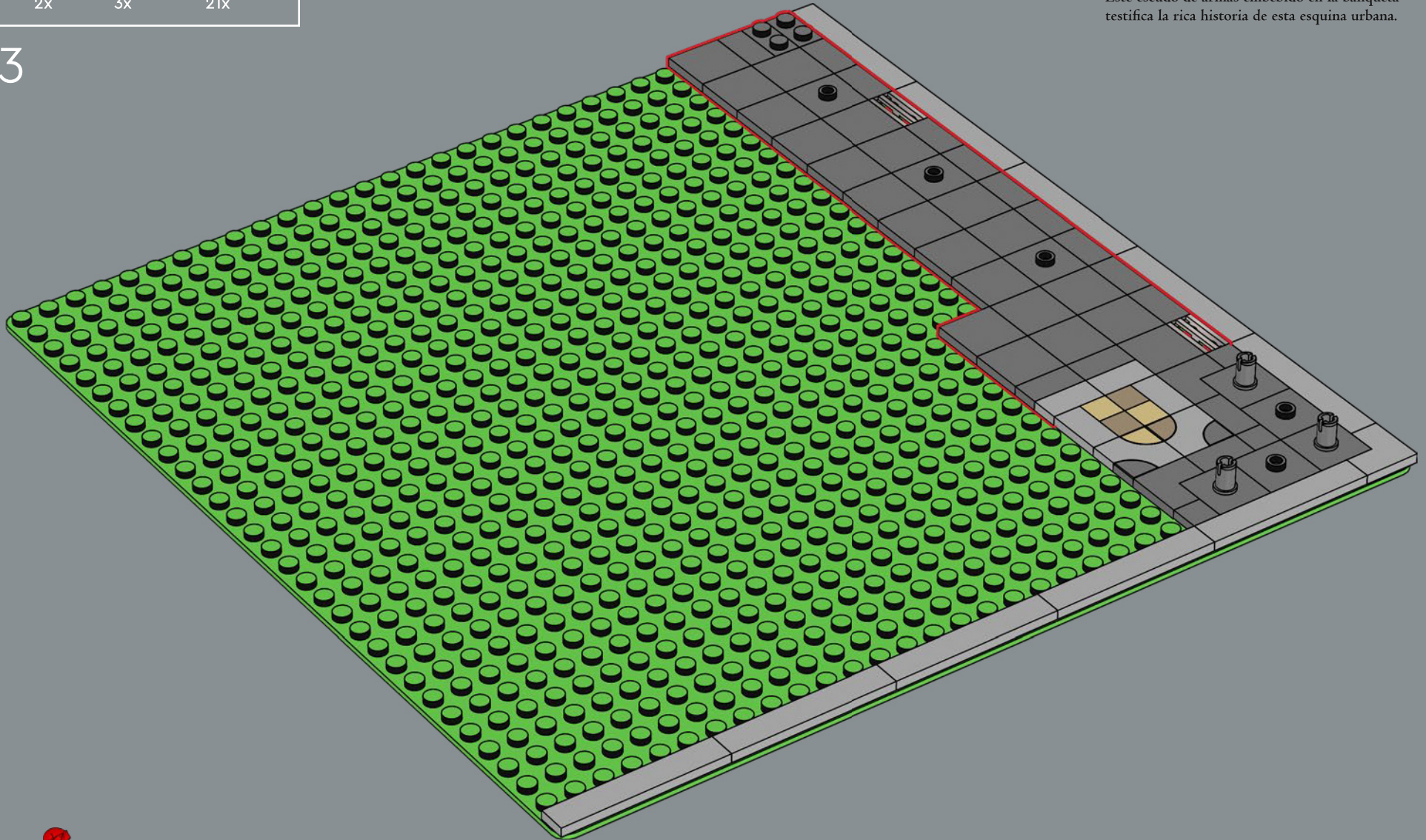

This coat of arms embedded in the sidewalk testifies to the rich history of this street corner.

Ce blason incrusté dans le trottoir témoigne de la riche histoire de ce coin de rue.

Este escudo de armas embebido en la banqueta testifica la rica historia de esta esquina urbana.



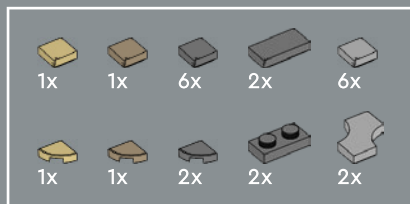

4

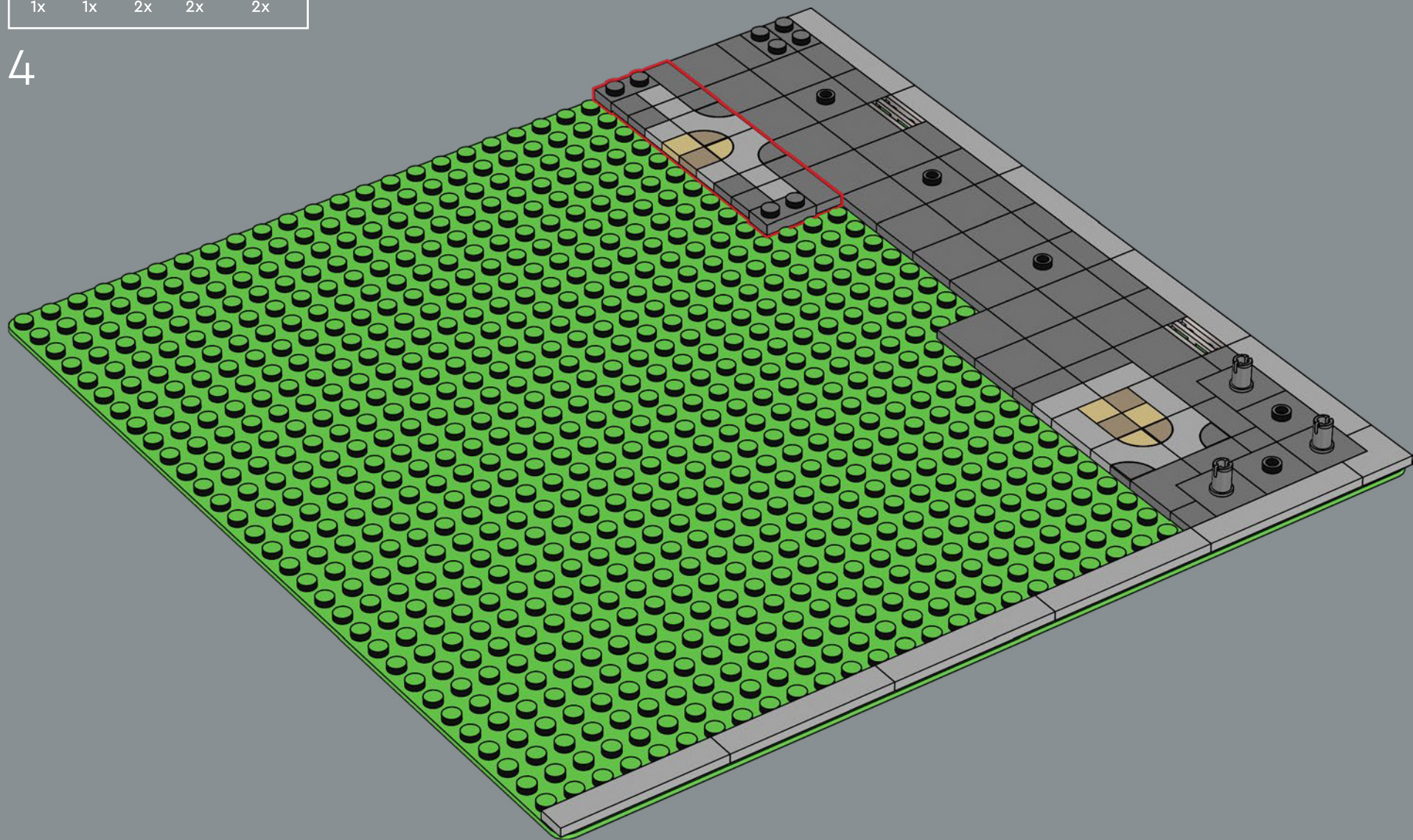

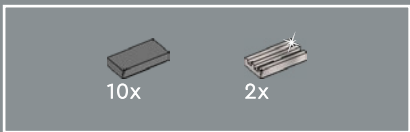

5

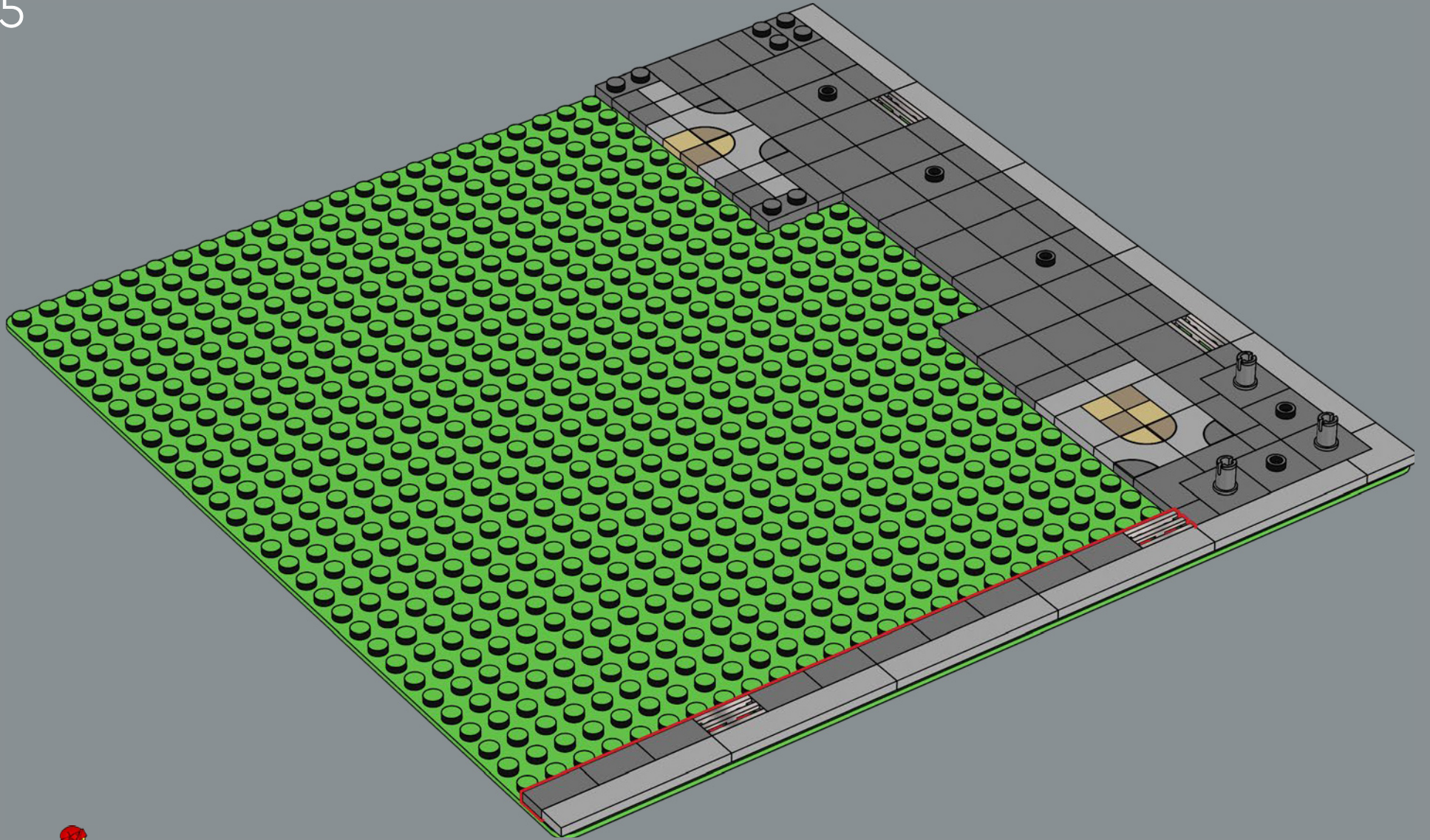

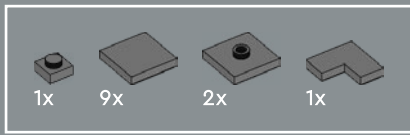

6

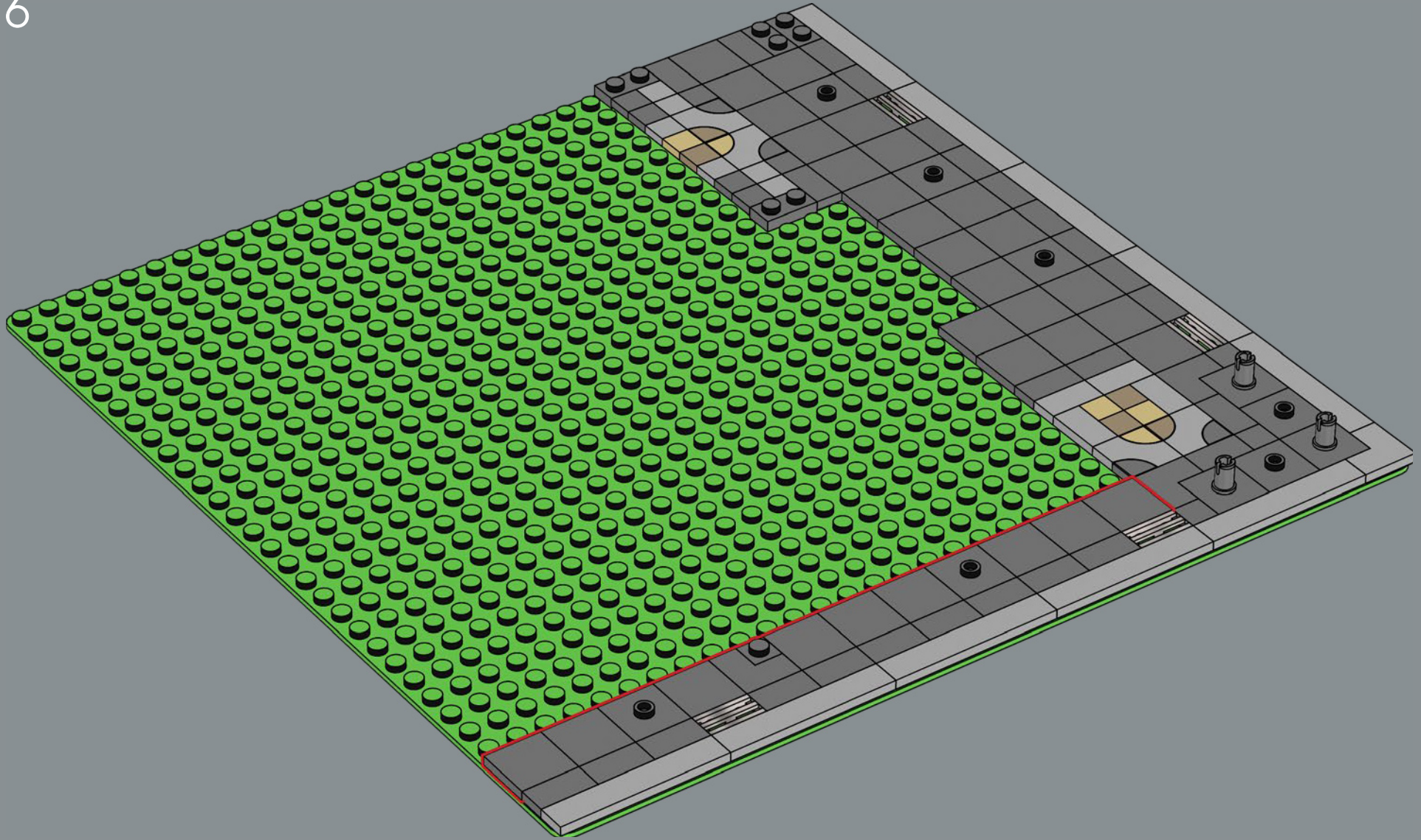

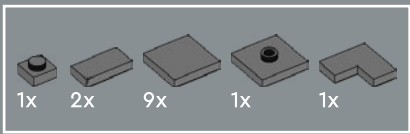

7

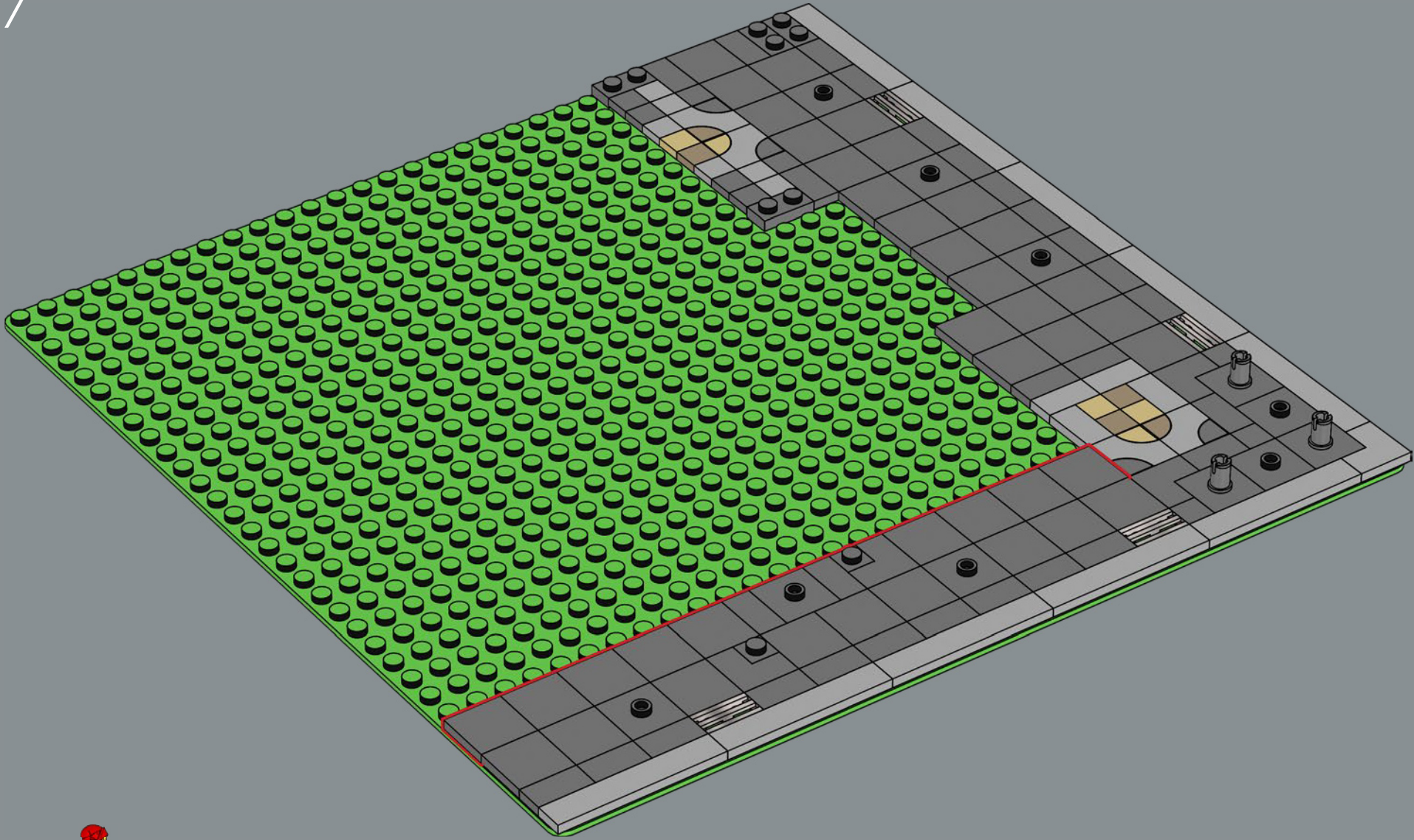

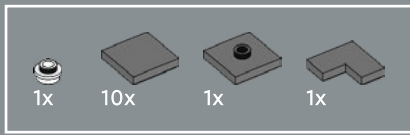

8

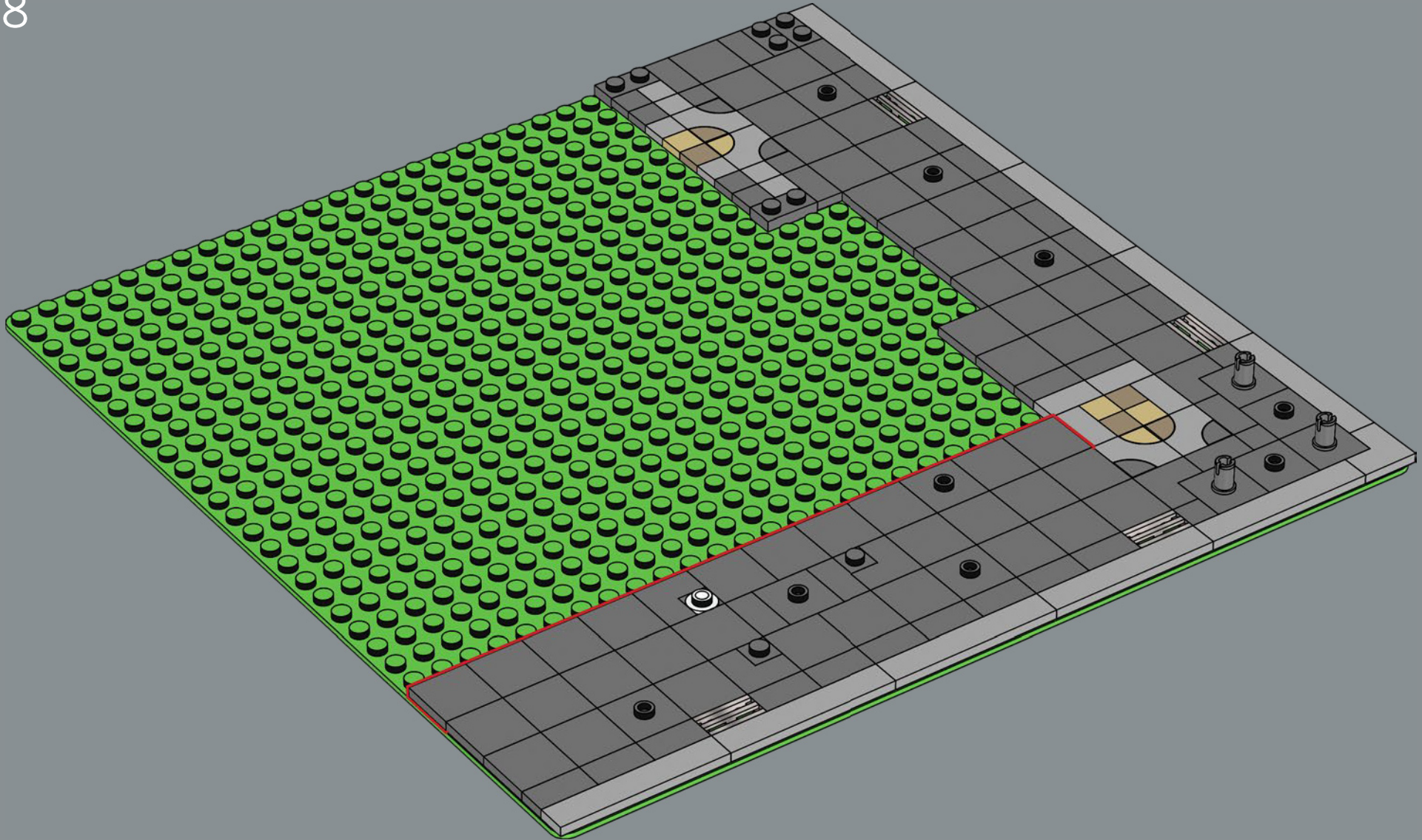

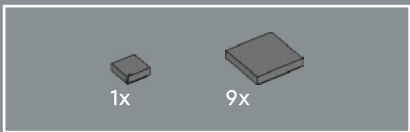

9

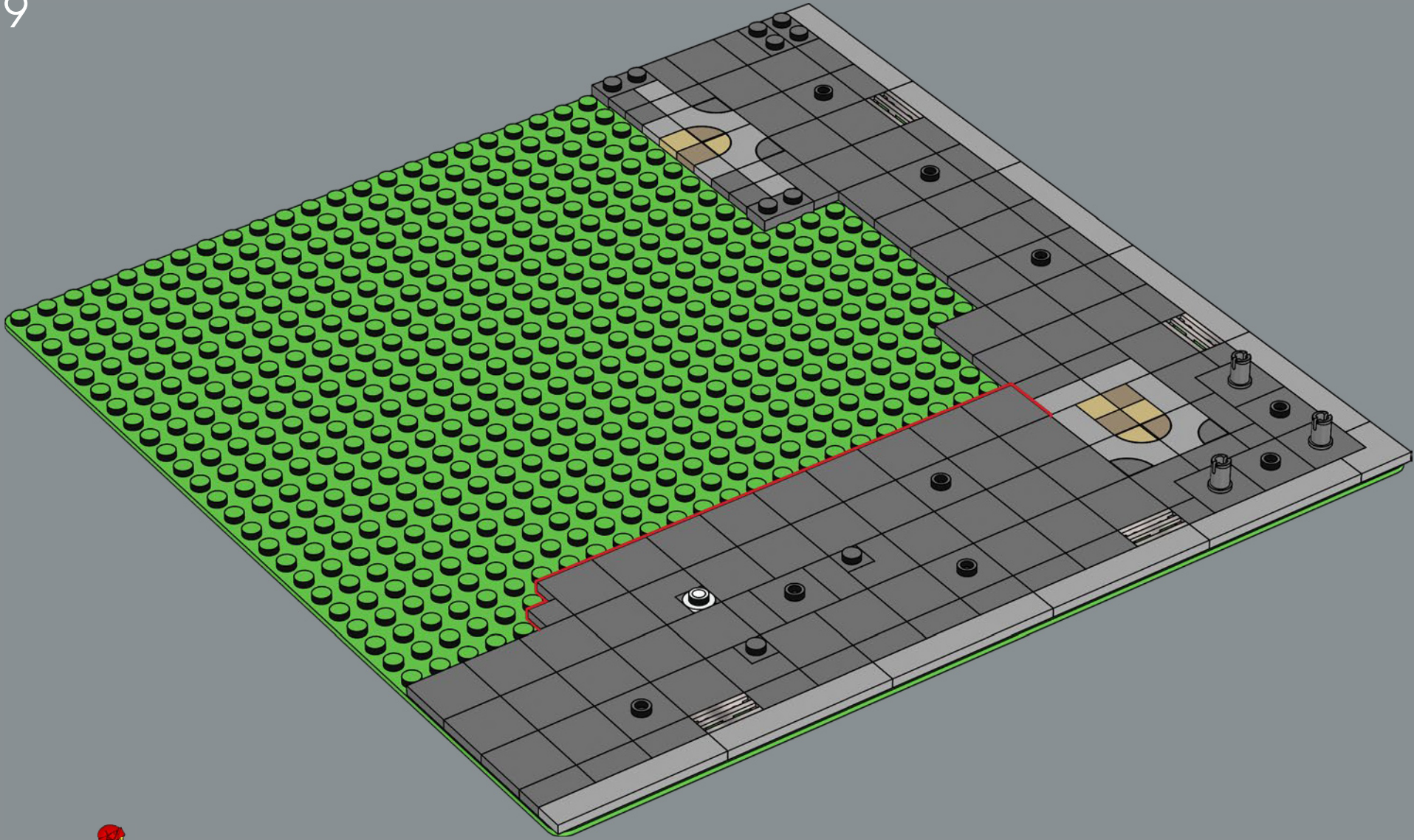



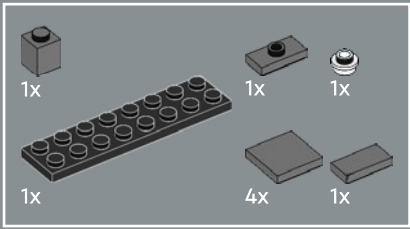

10

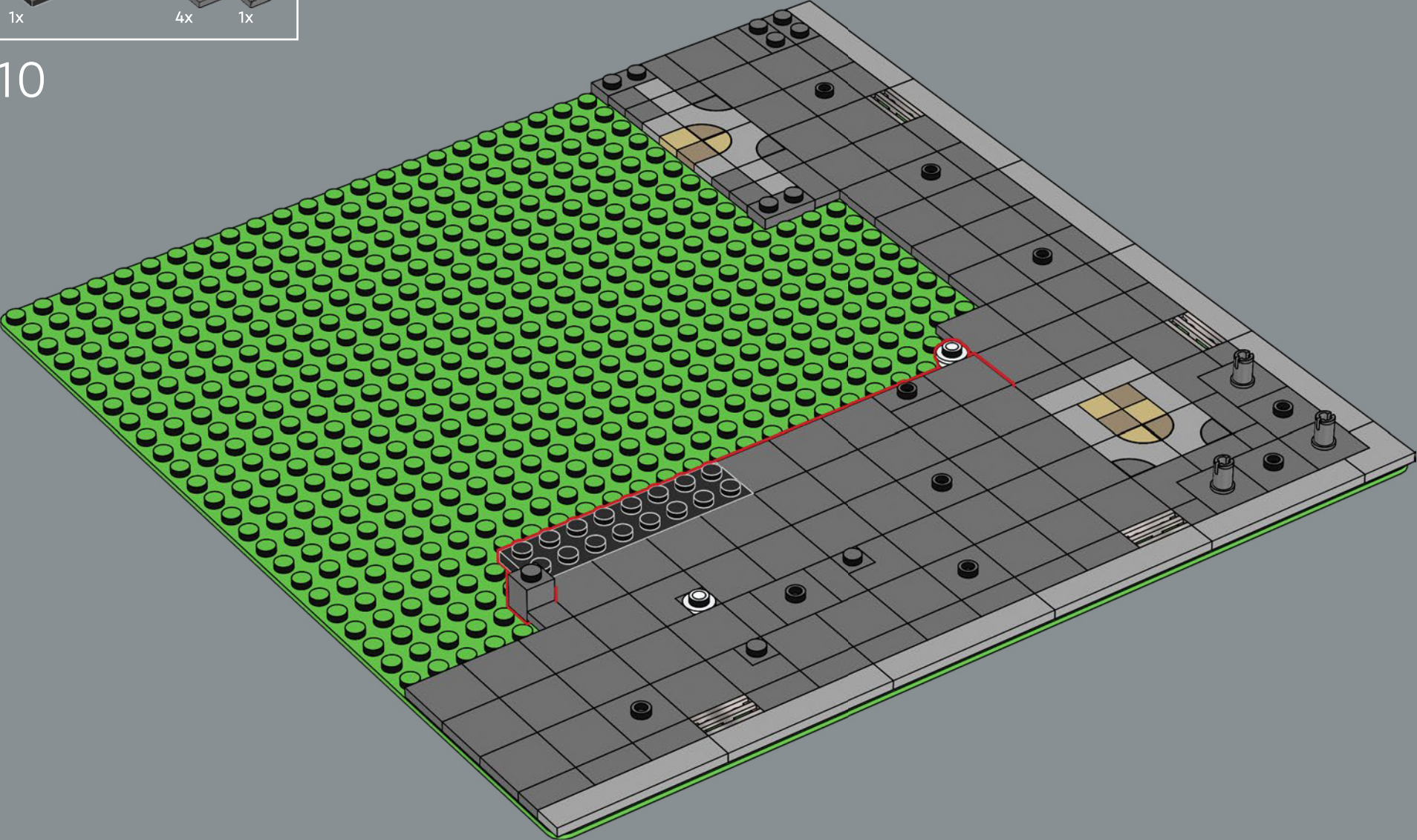

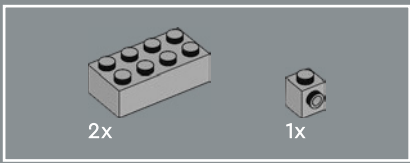

11

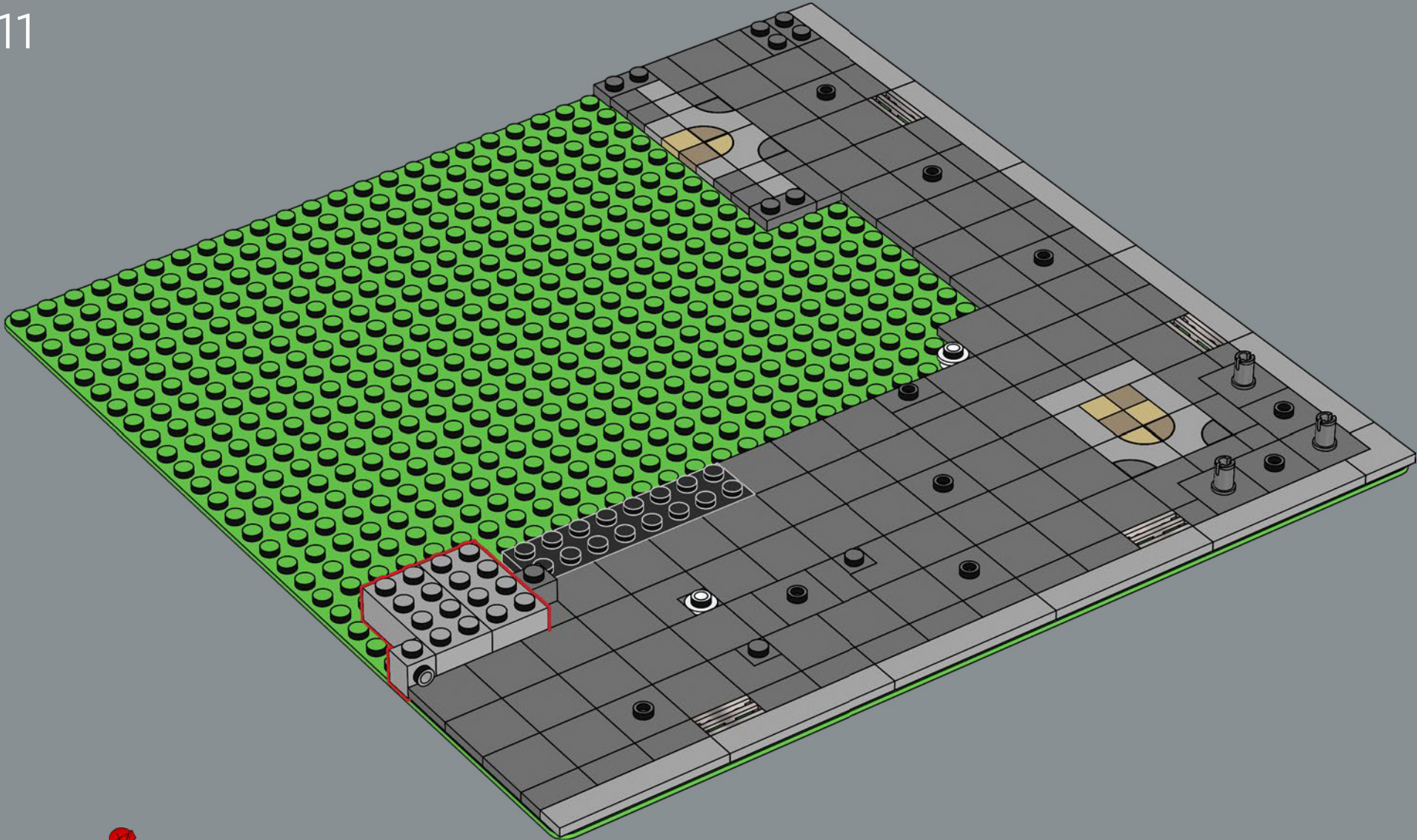

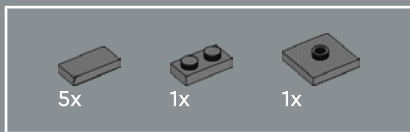

12

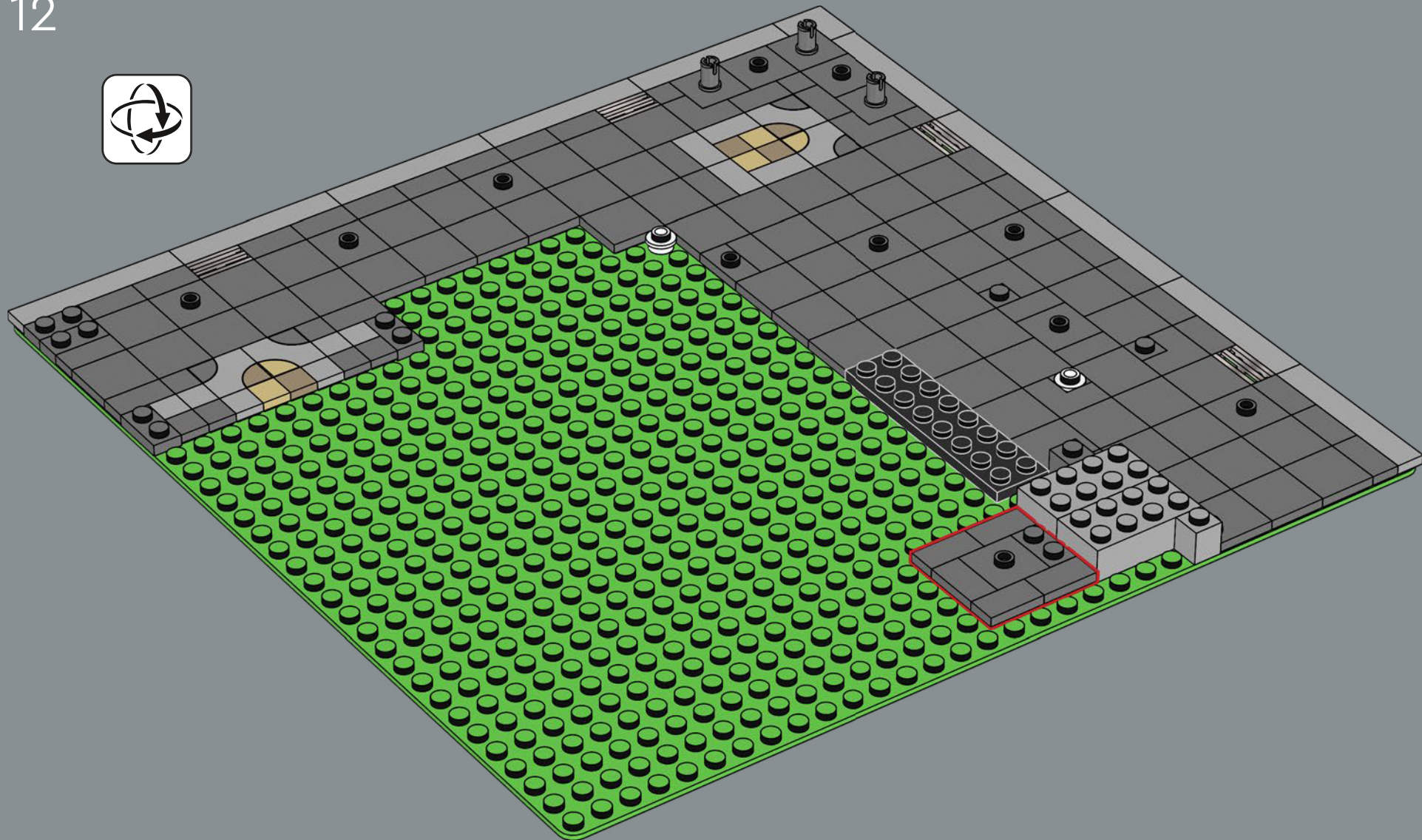

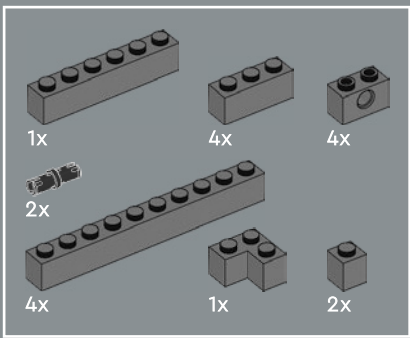

13

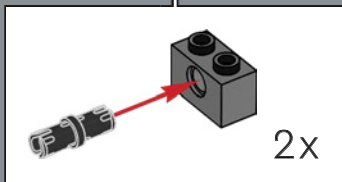
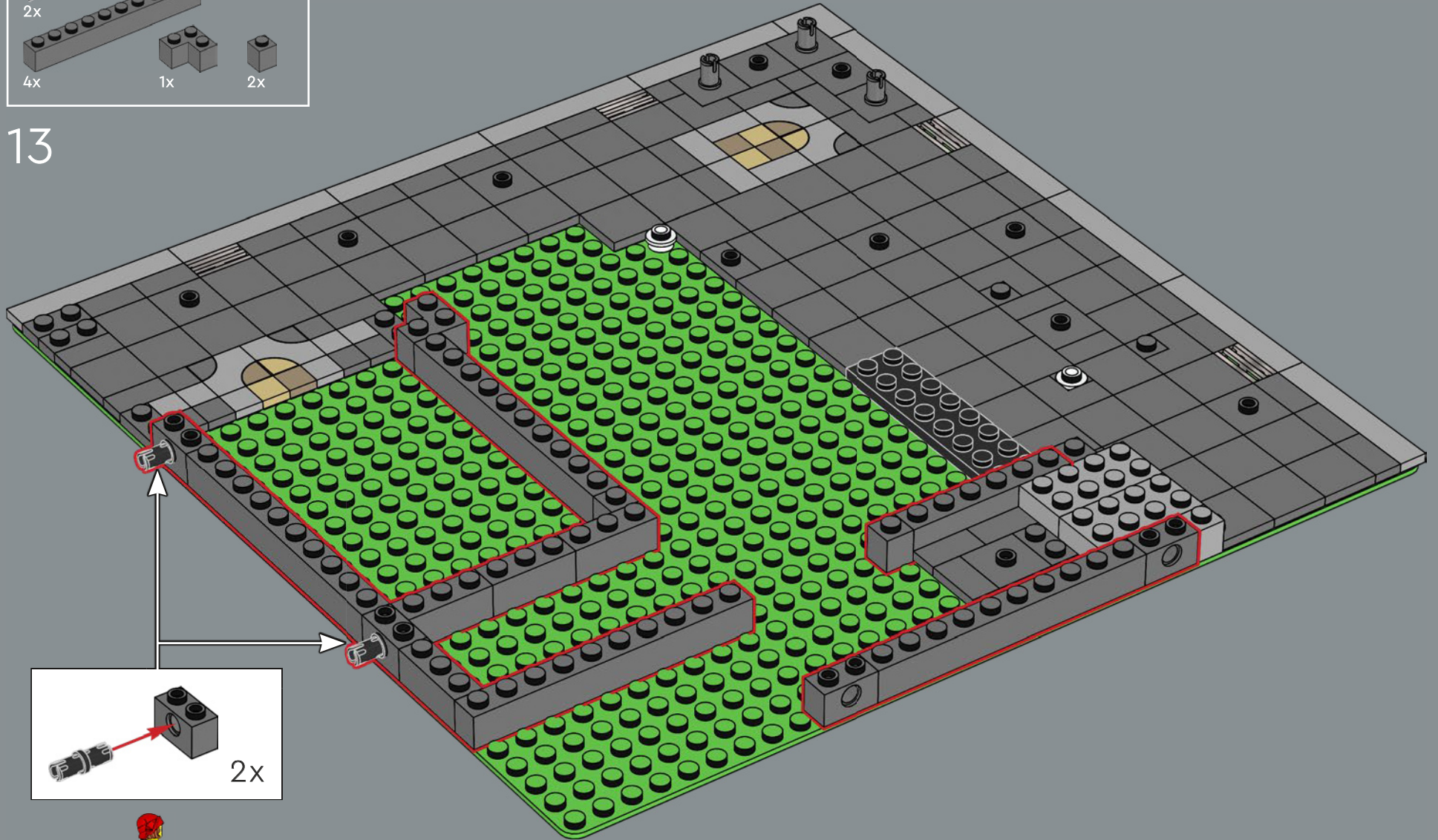

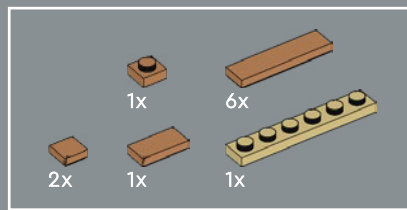

14

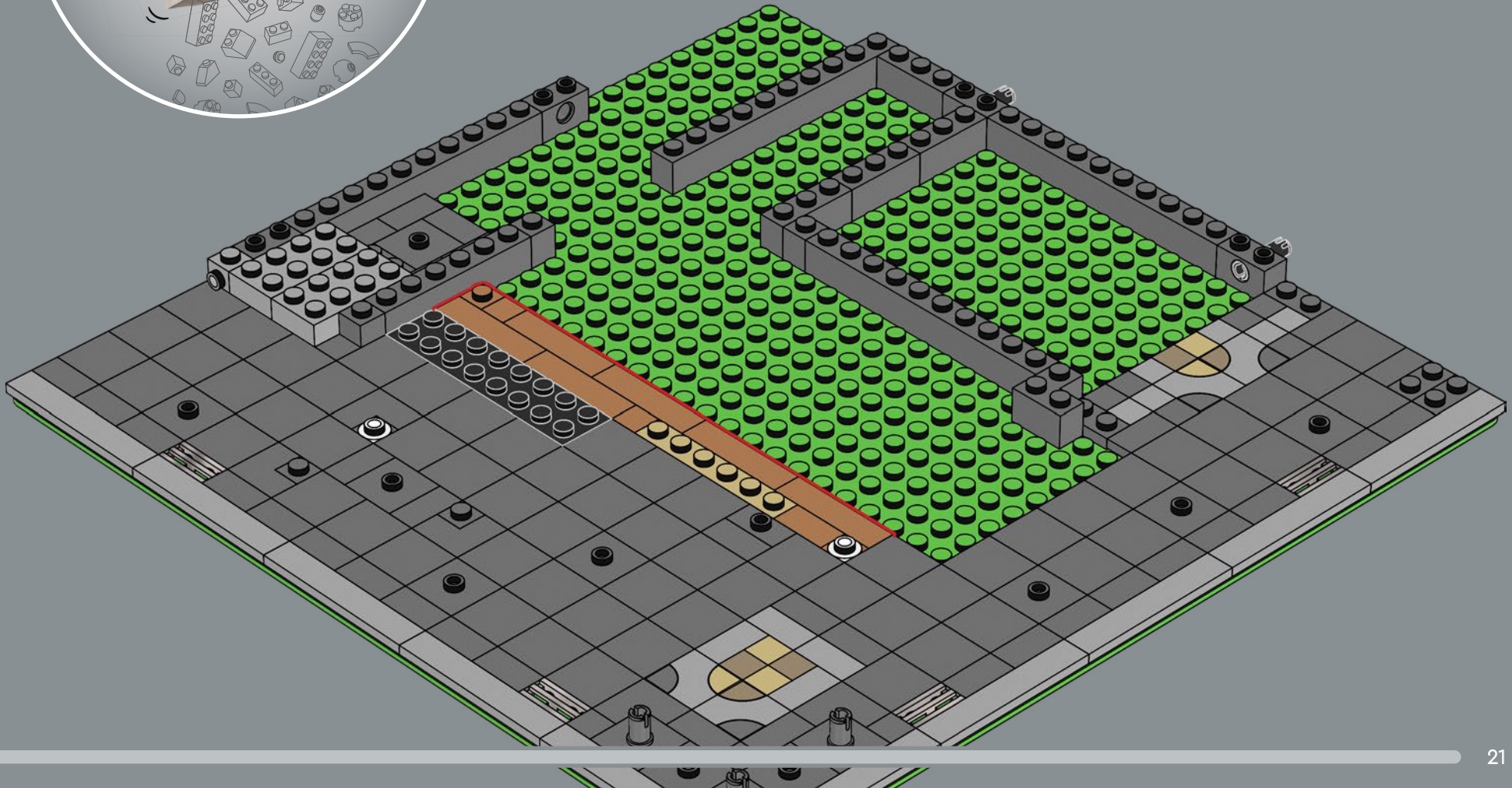

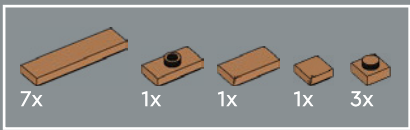

15

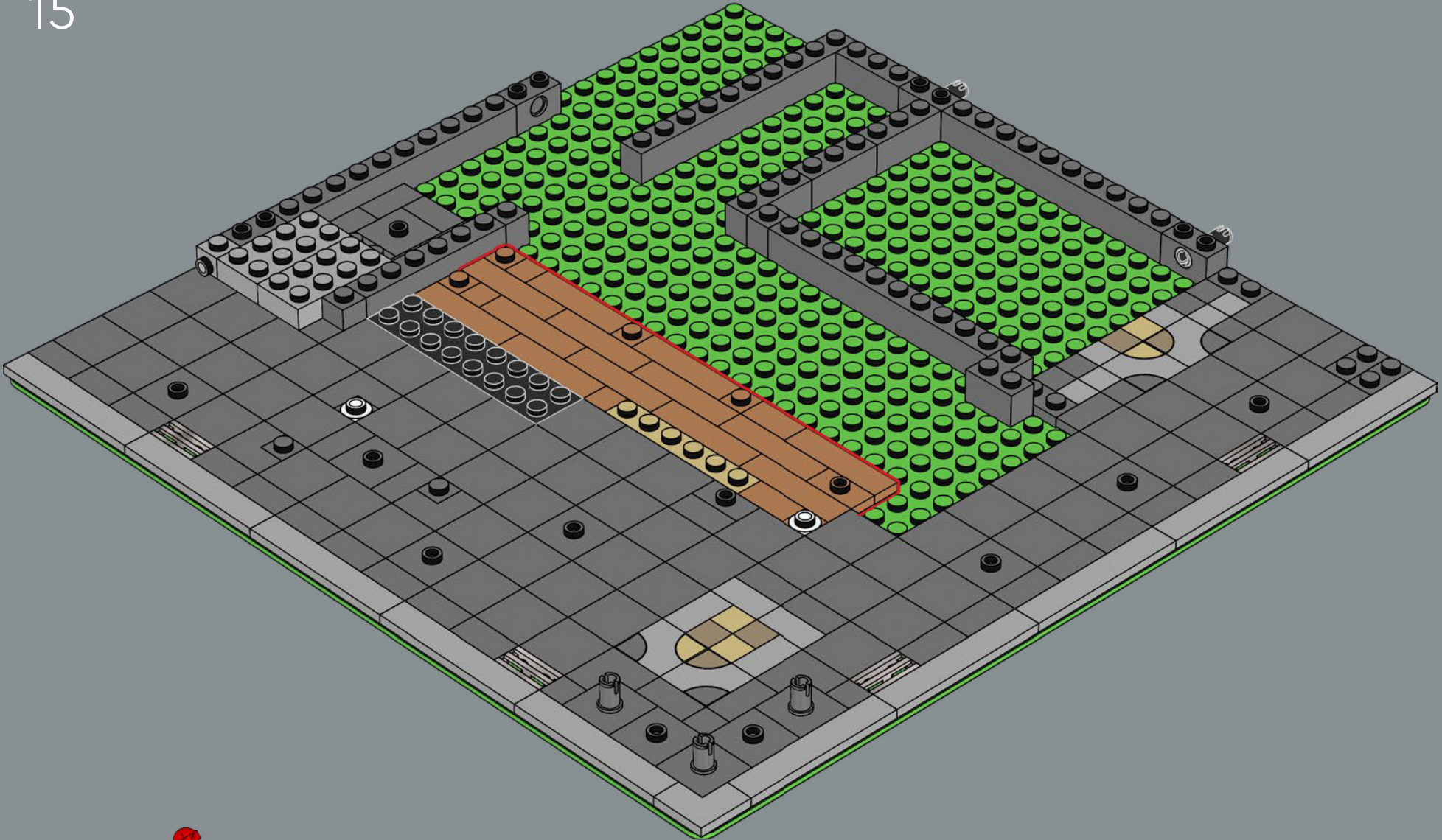

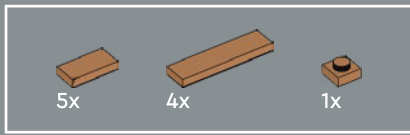

16

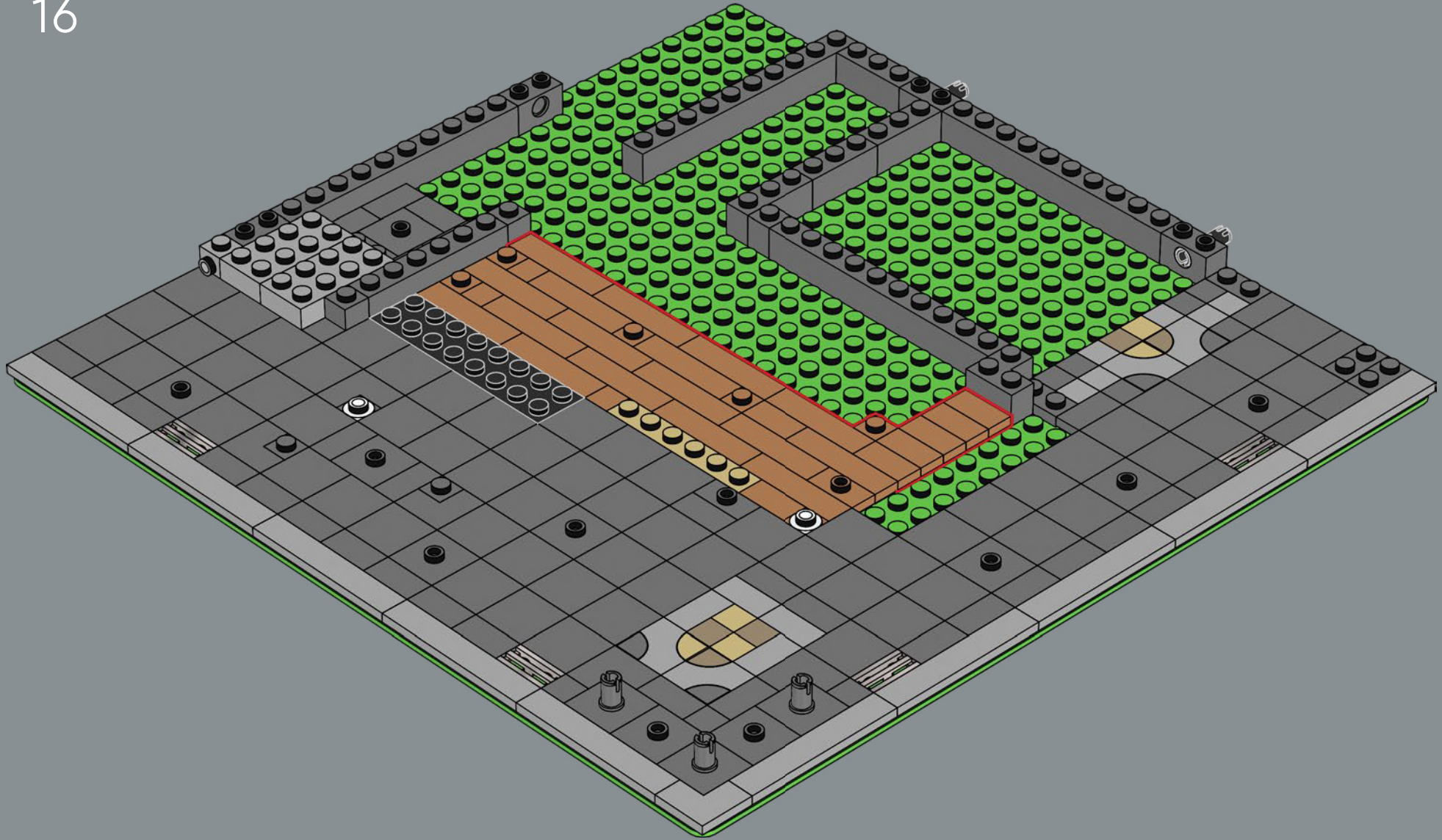

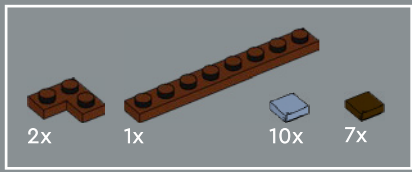

17

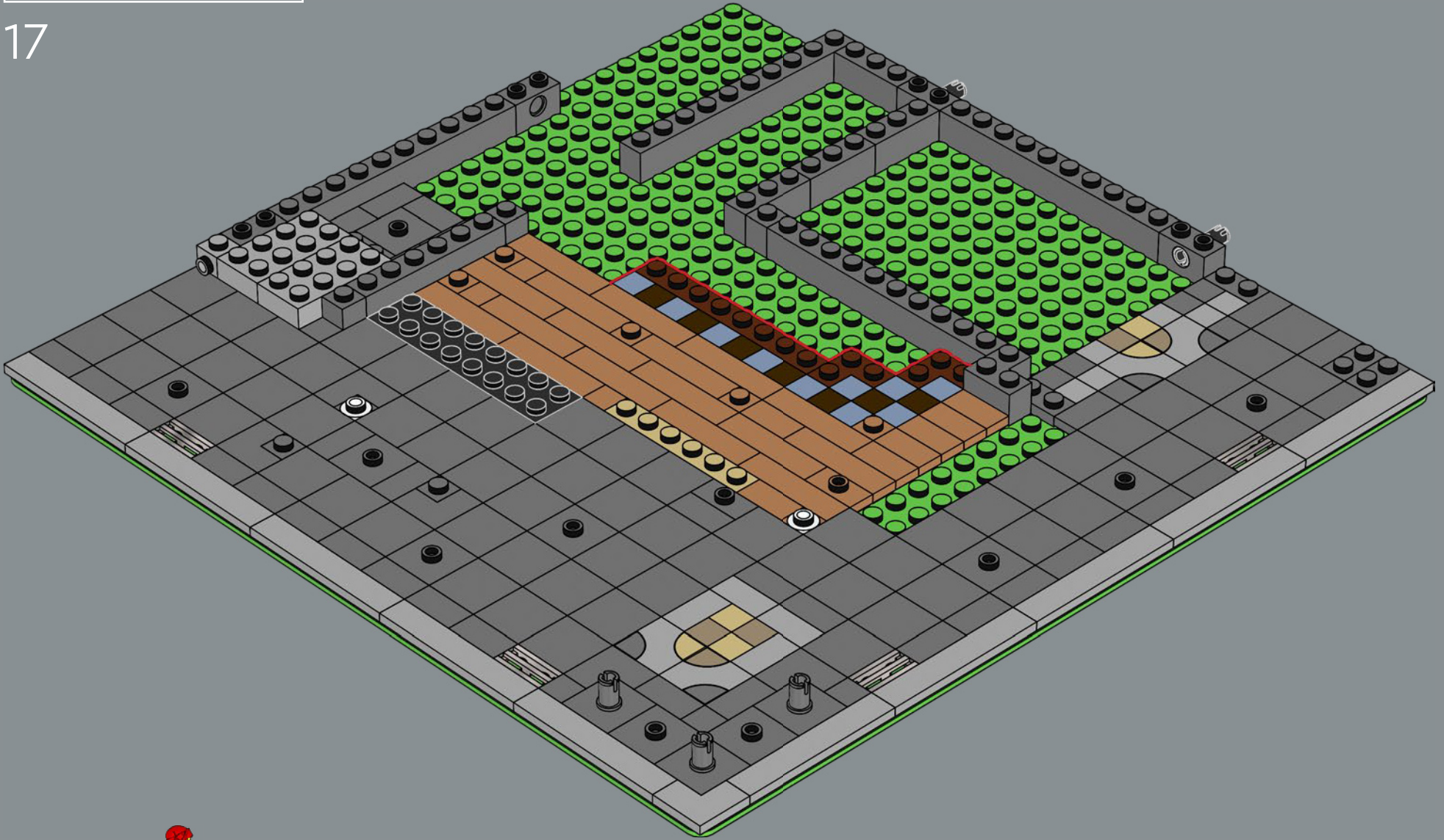



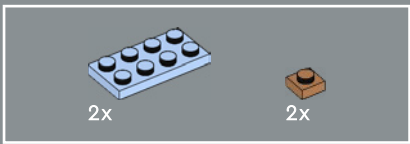

18

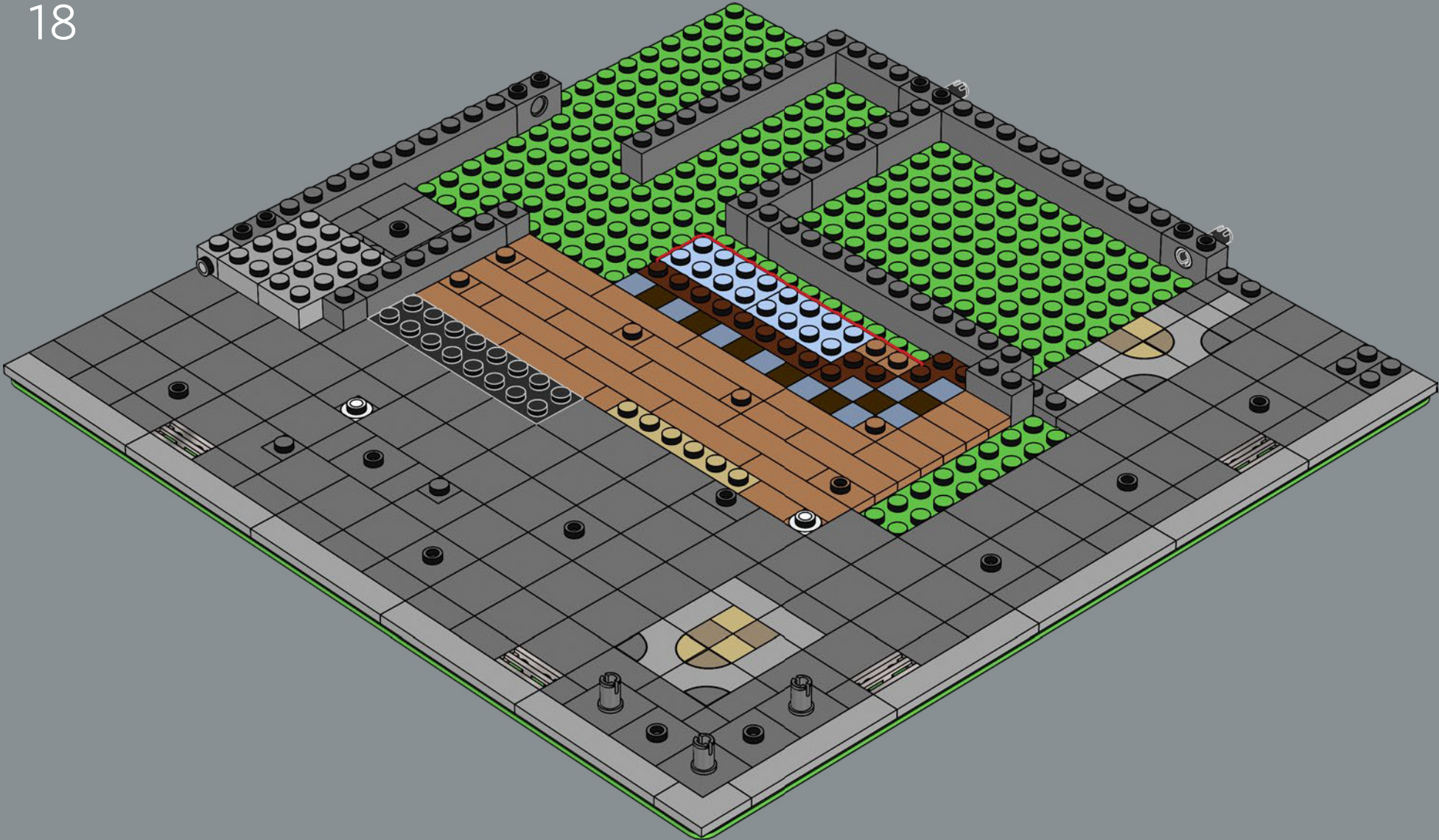

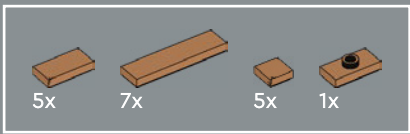

19

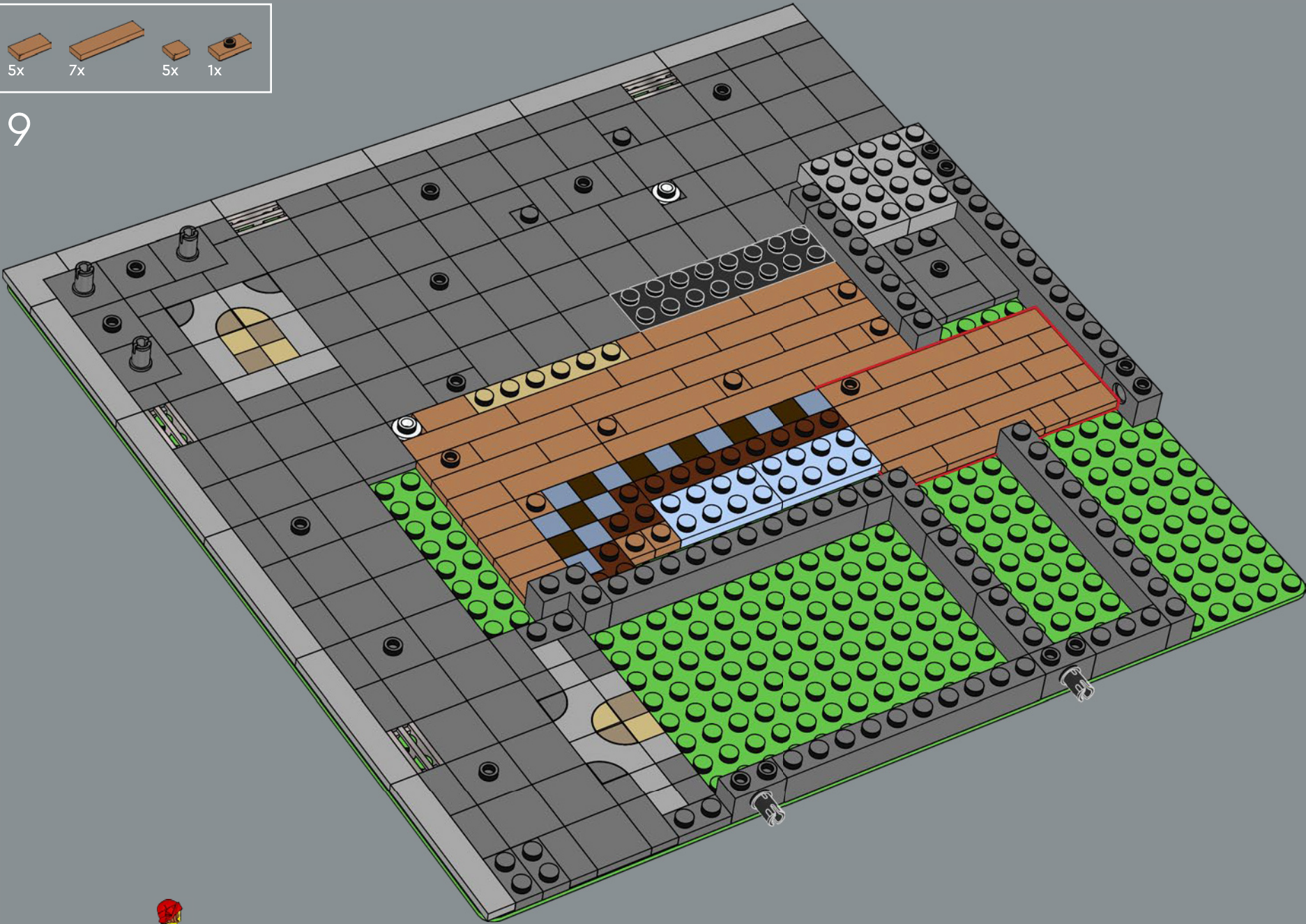

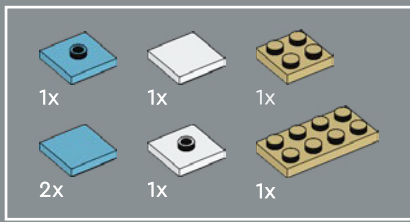

20

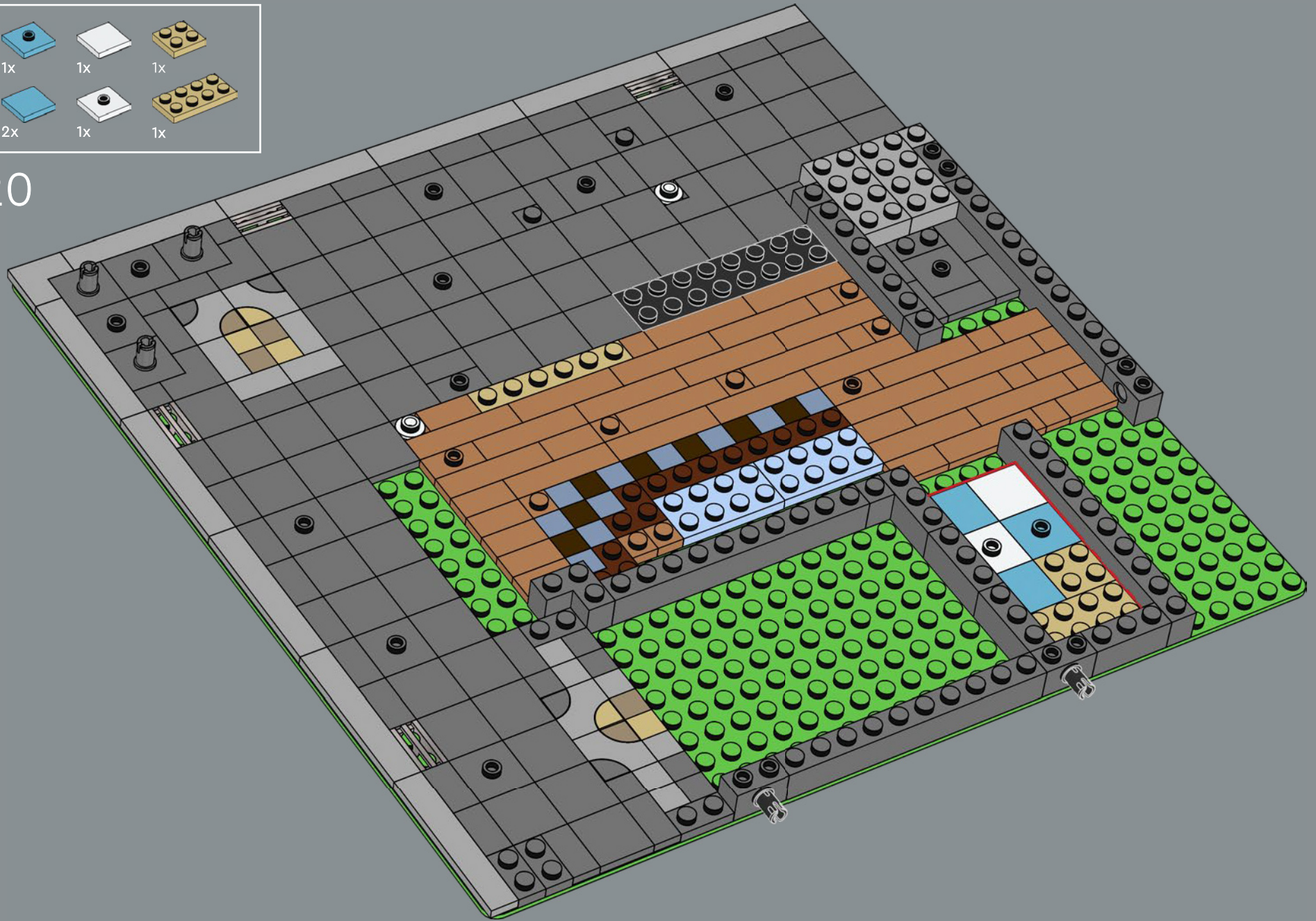

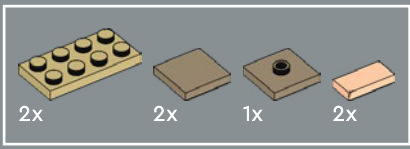

21

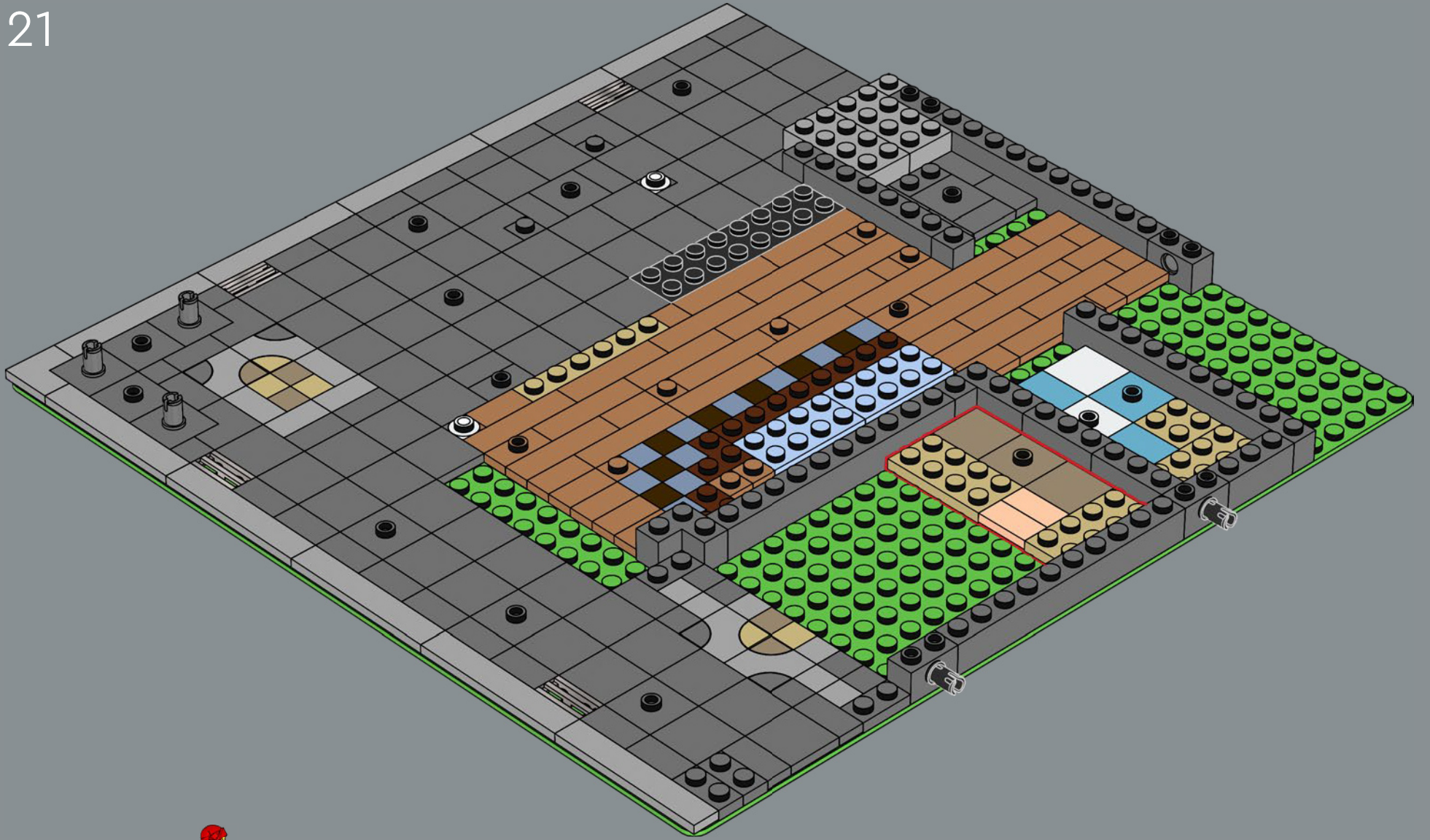



22

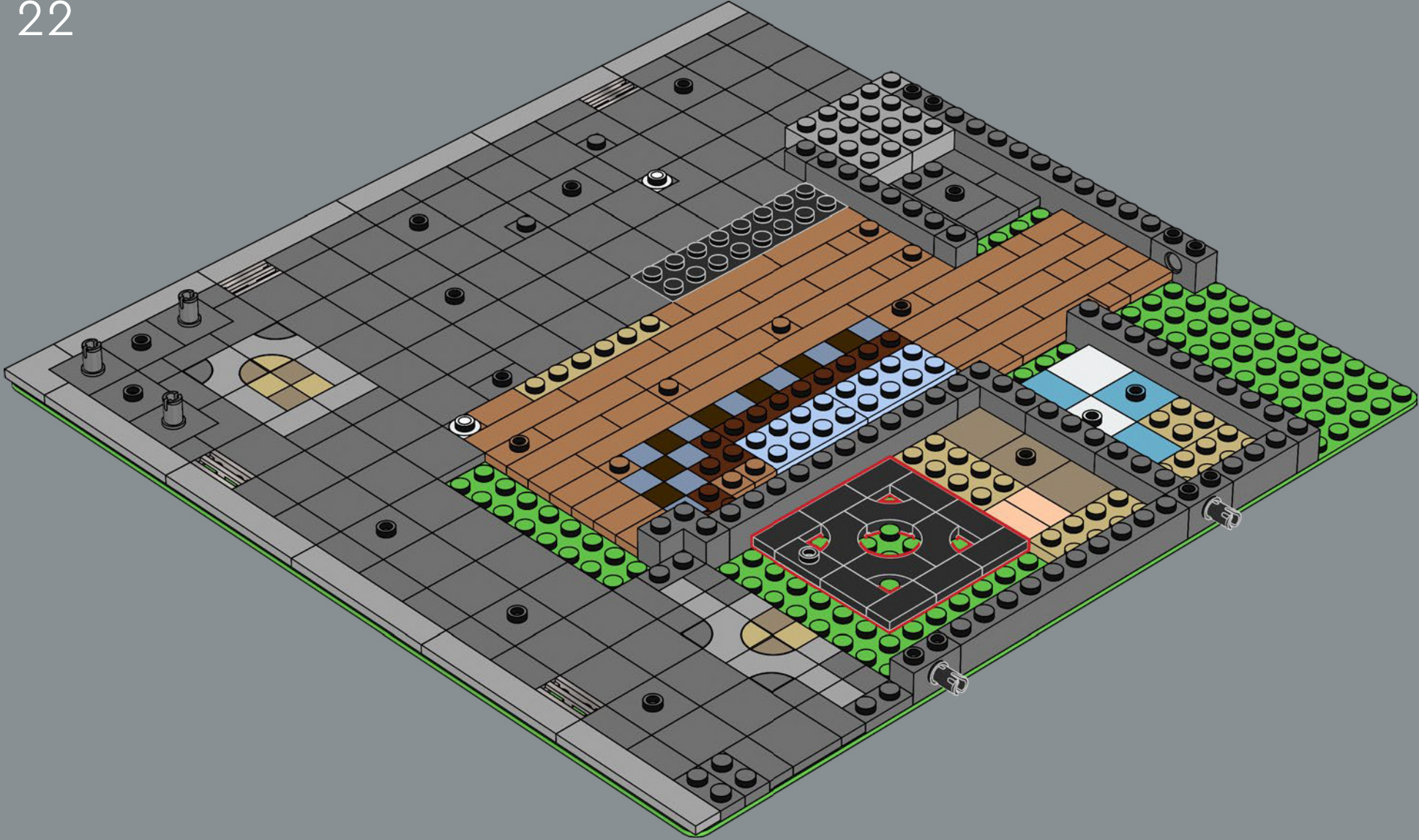

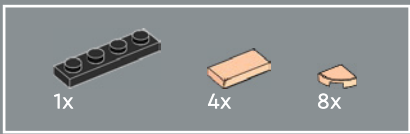

23

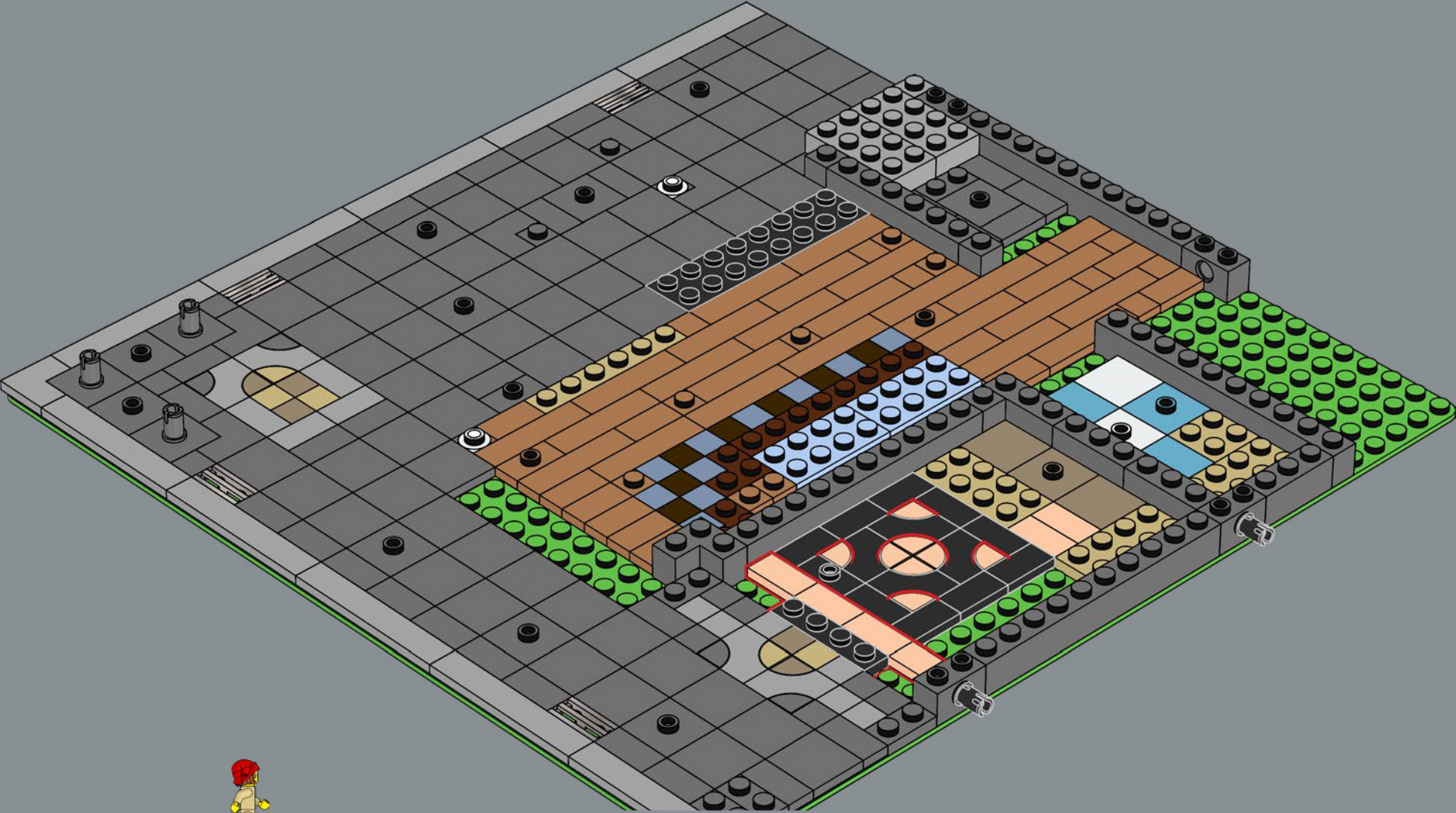

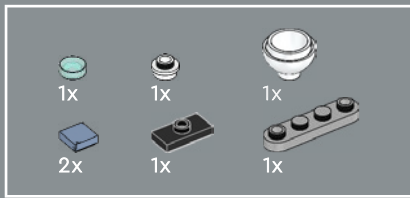

24

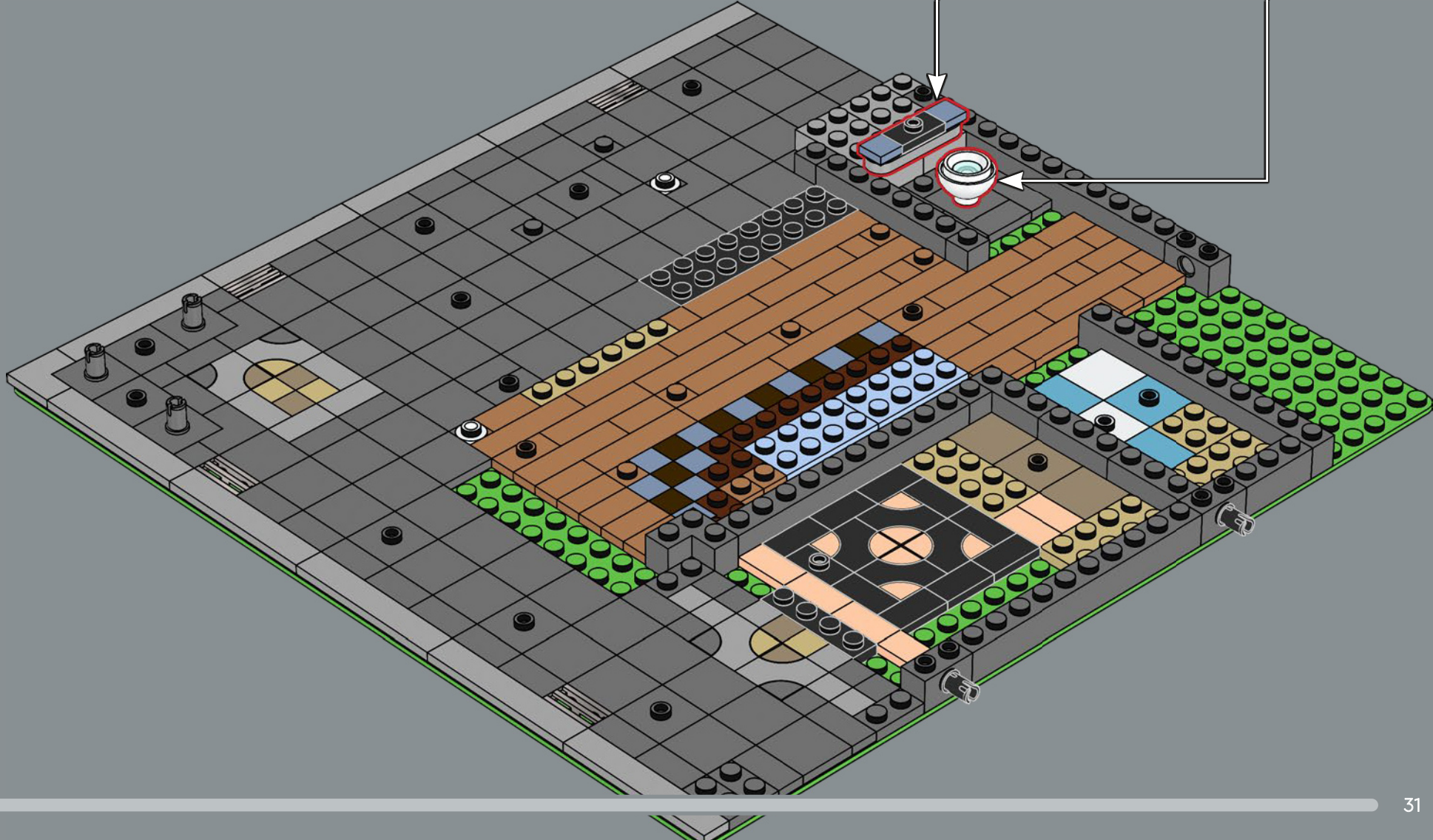
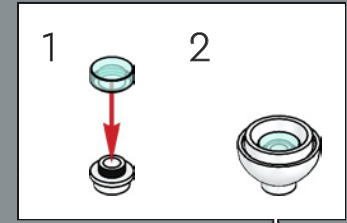
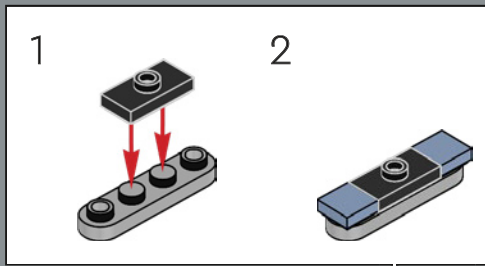

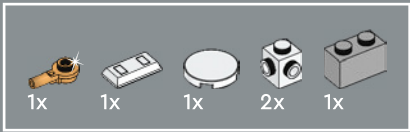

25

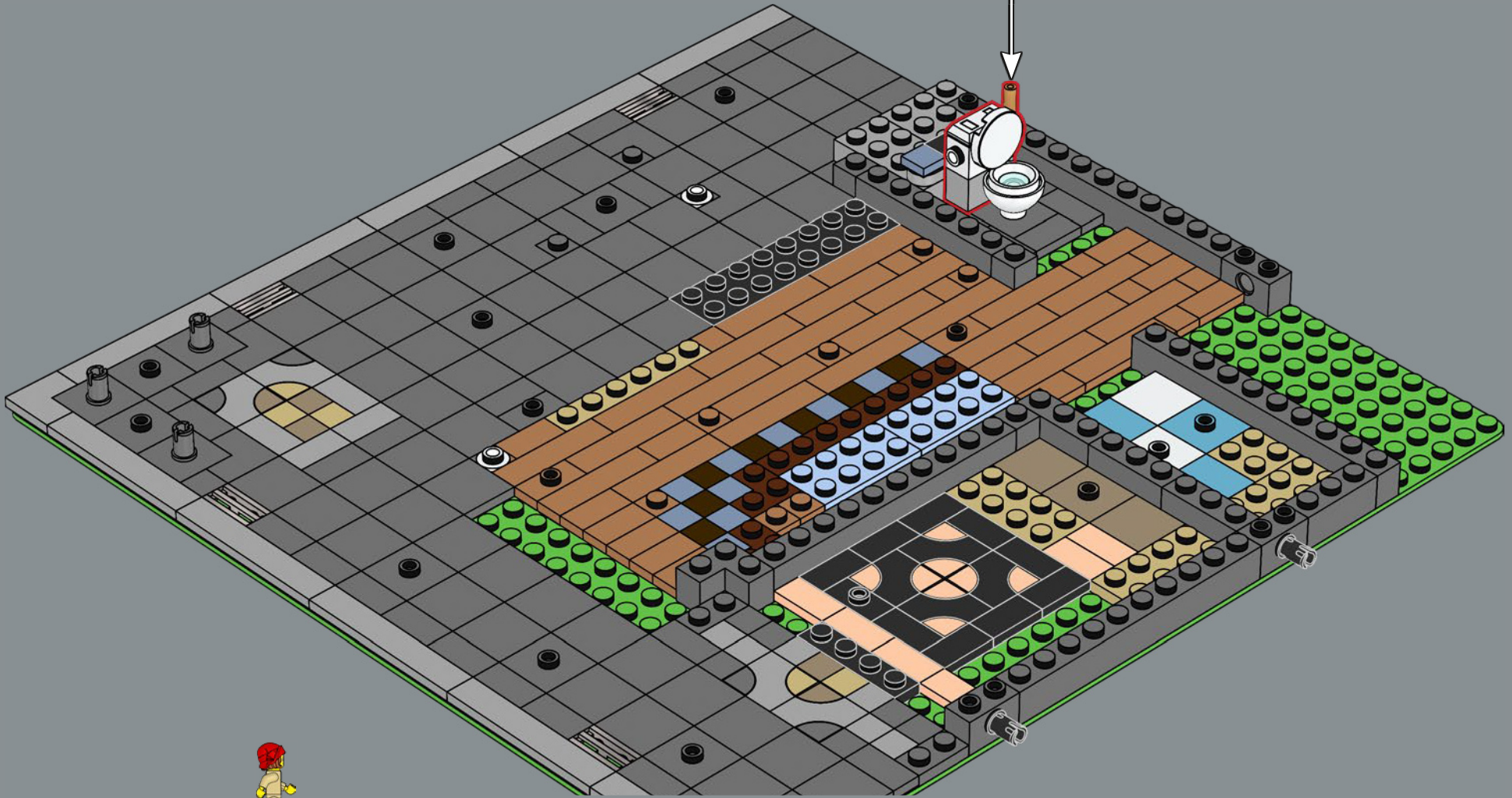
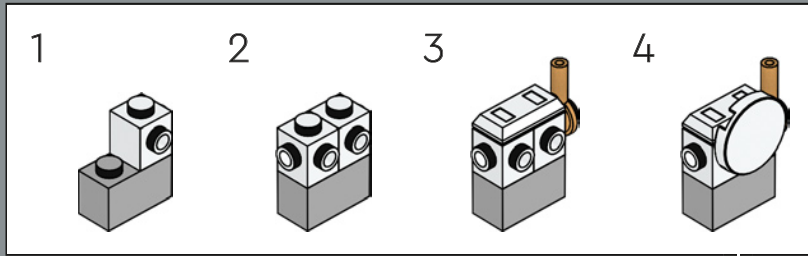



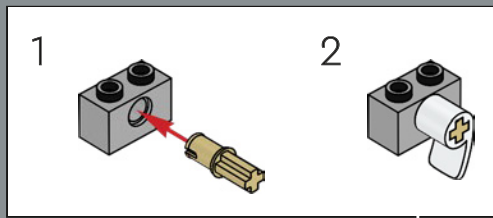
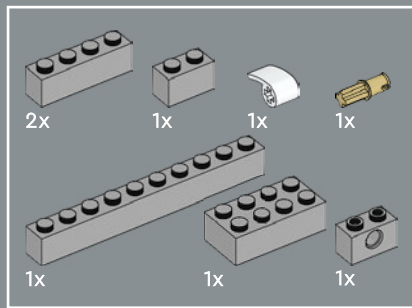

26

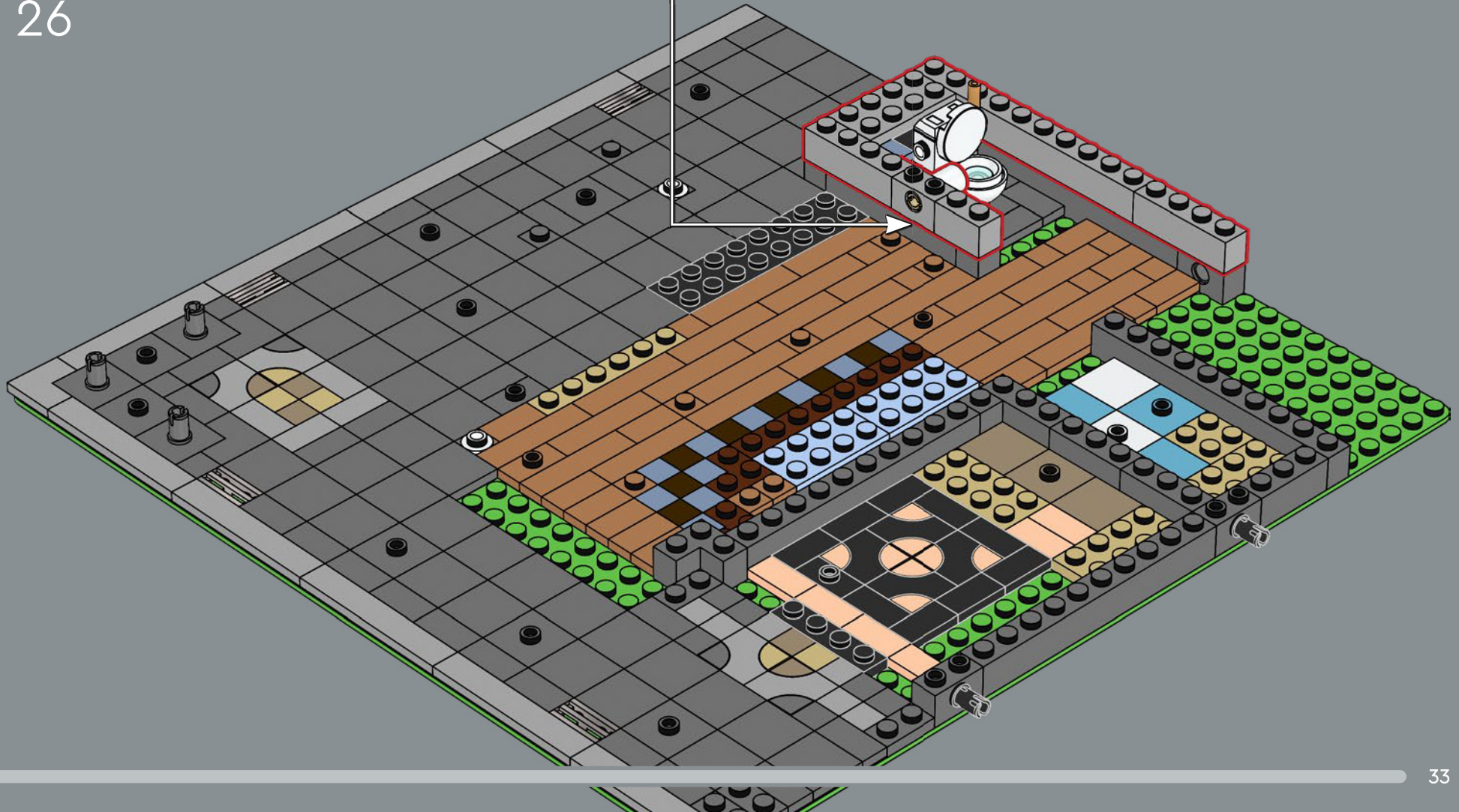

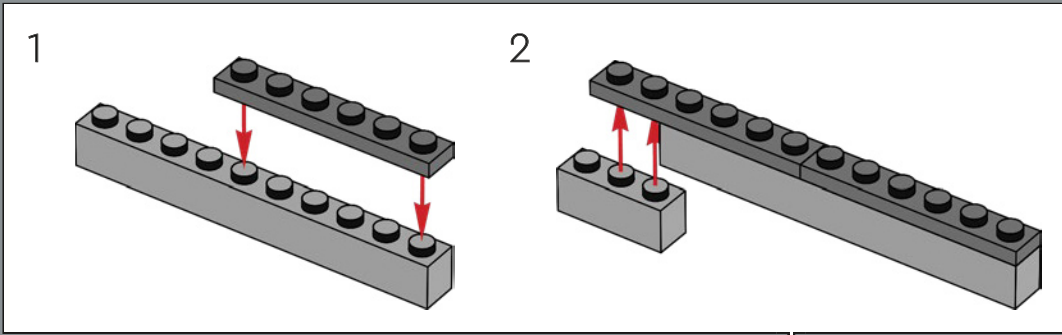
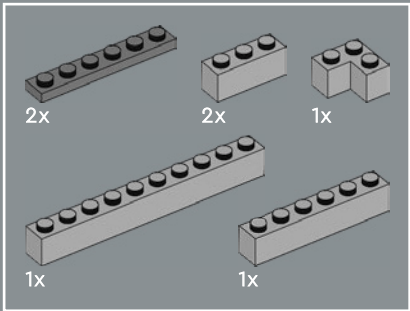

27

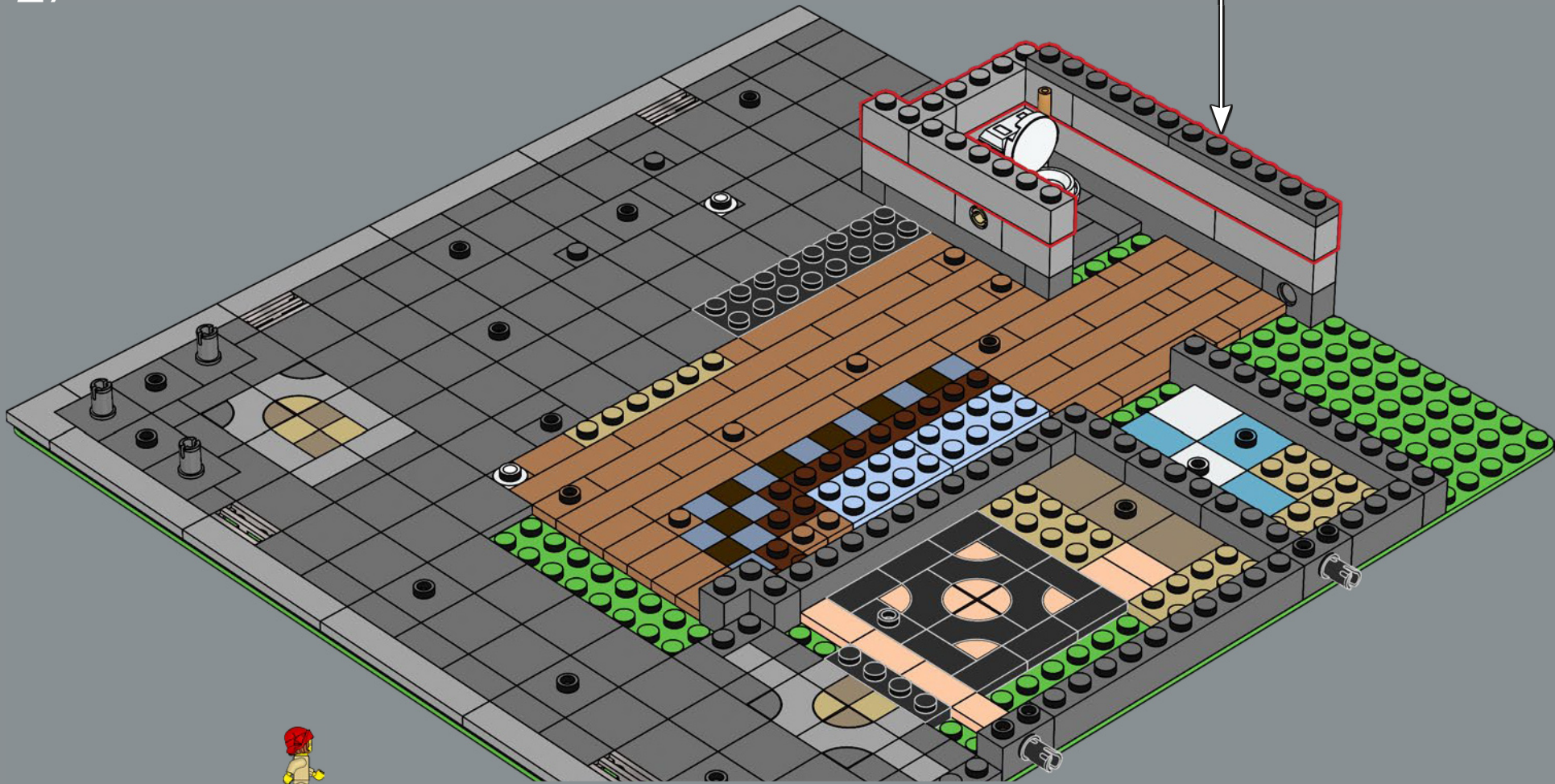

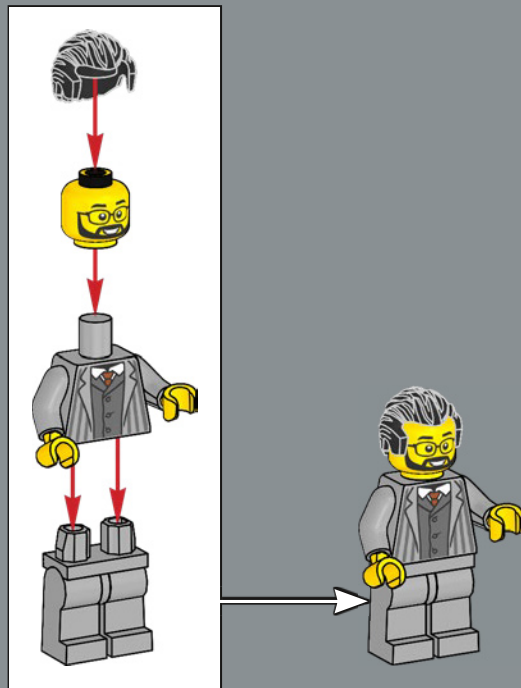

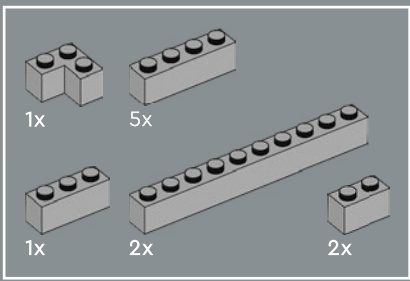

28

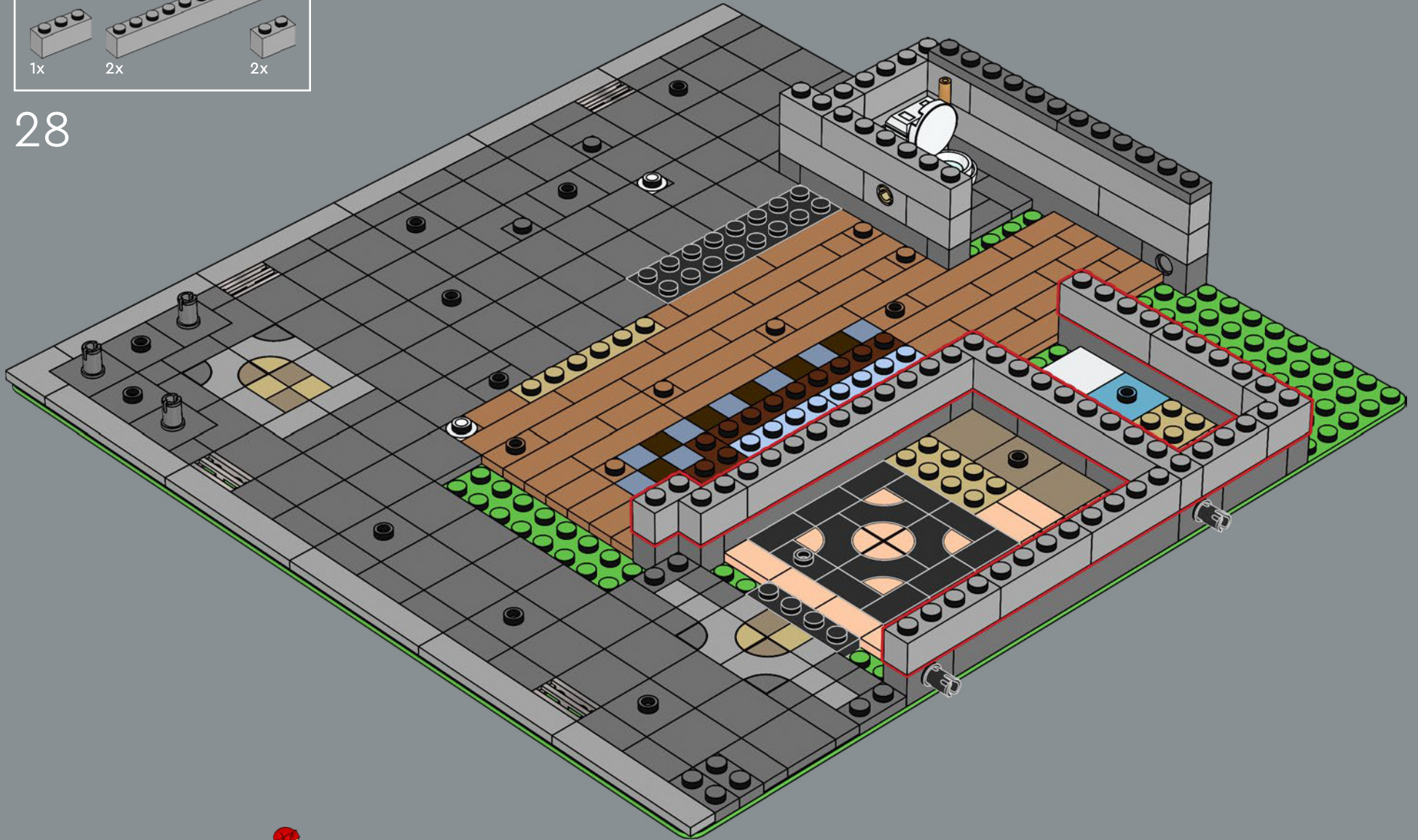

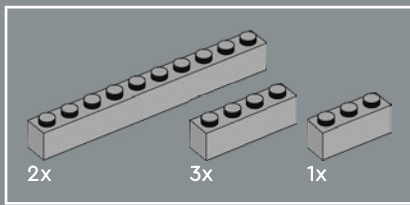

29

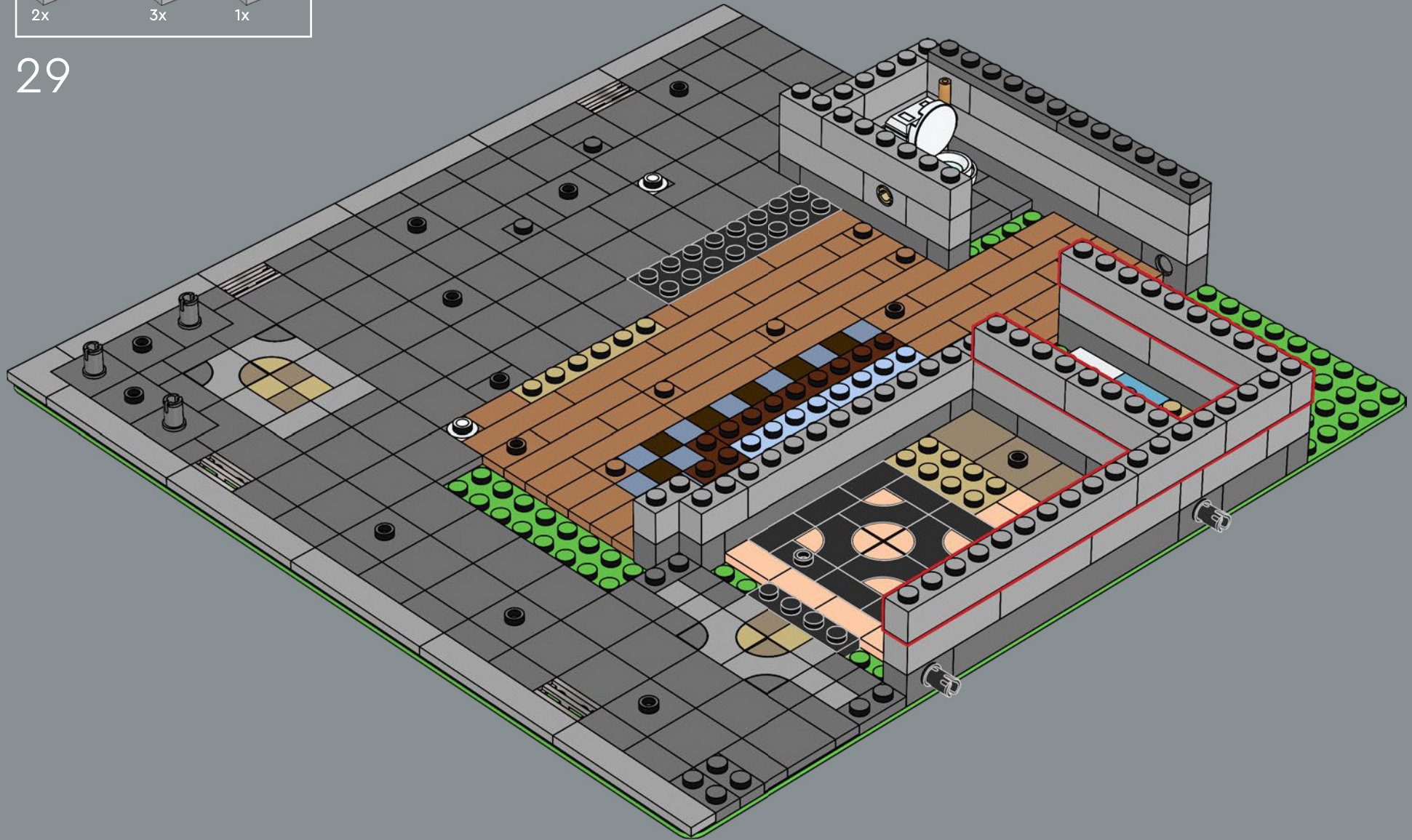

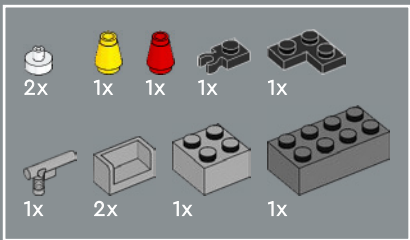

30

1

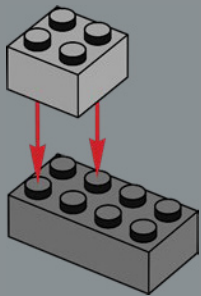

2

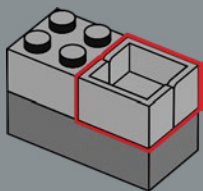

3

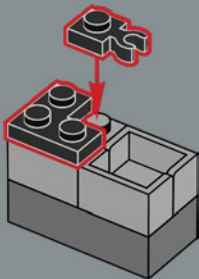

4

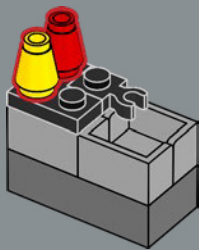

5

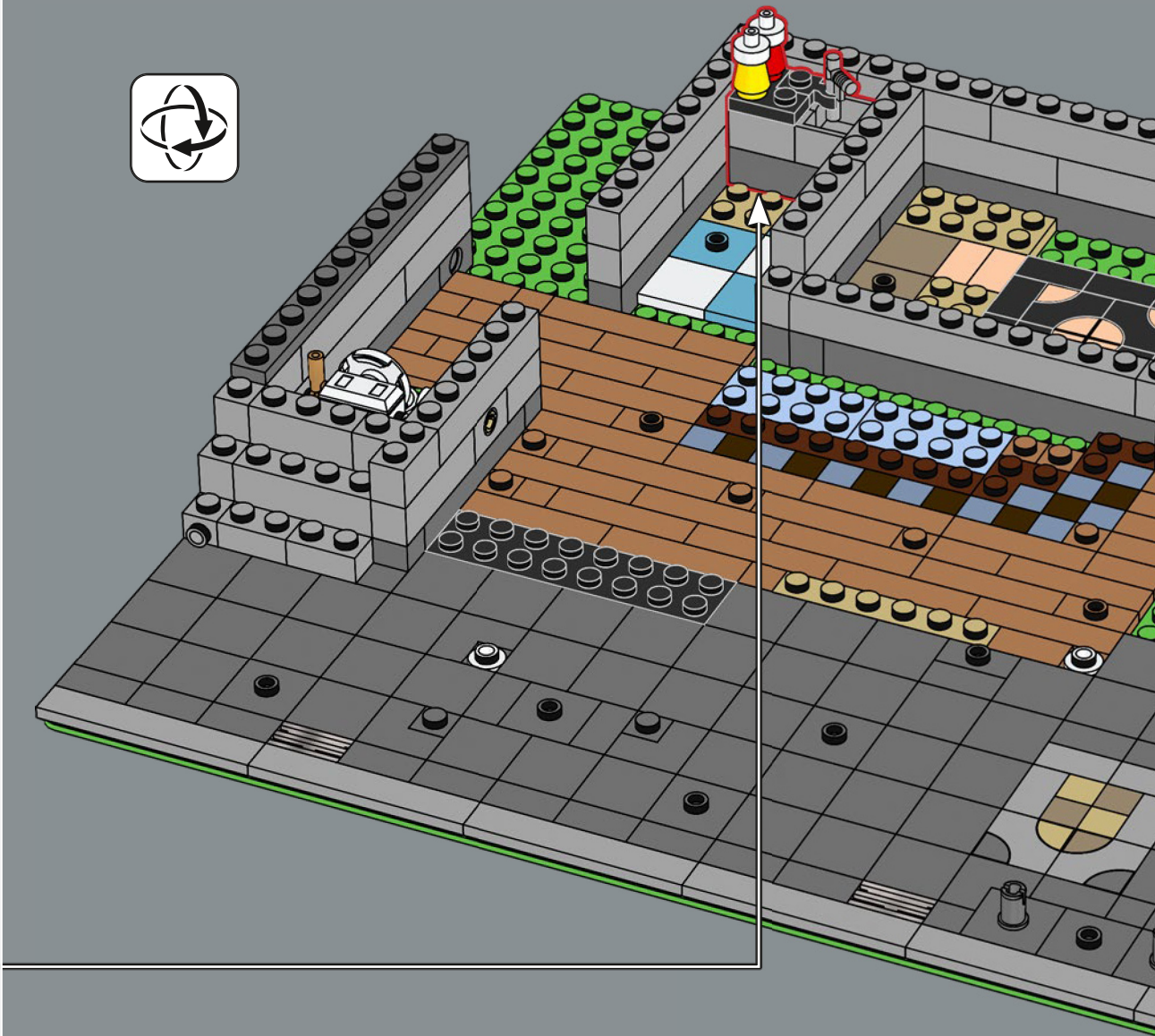
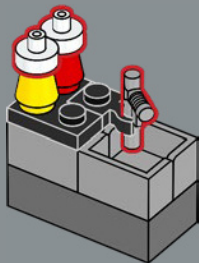

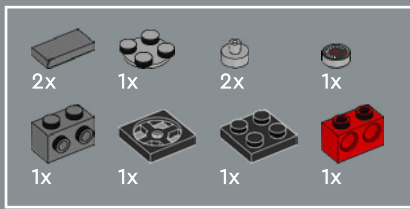

31

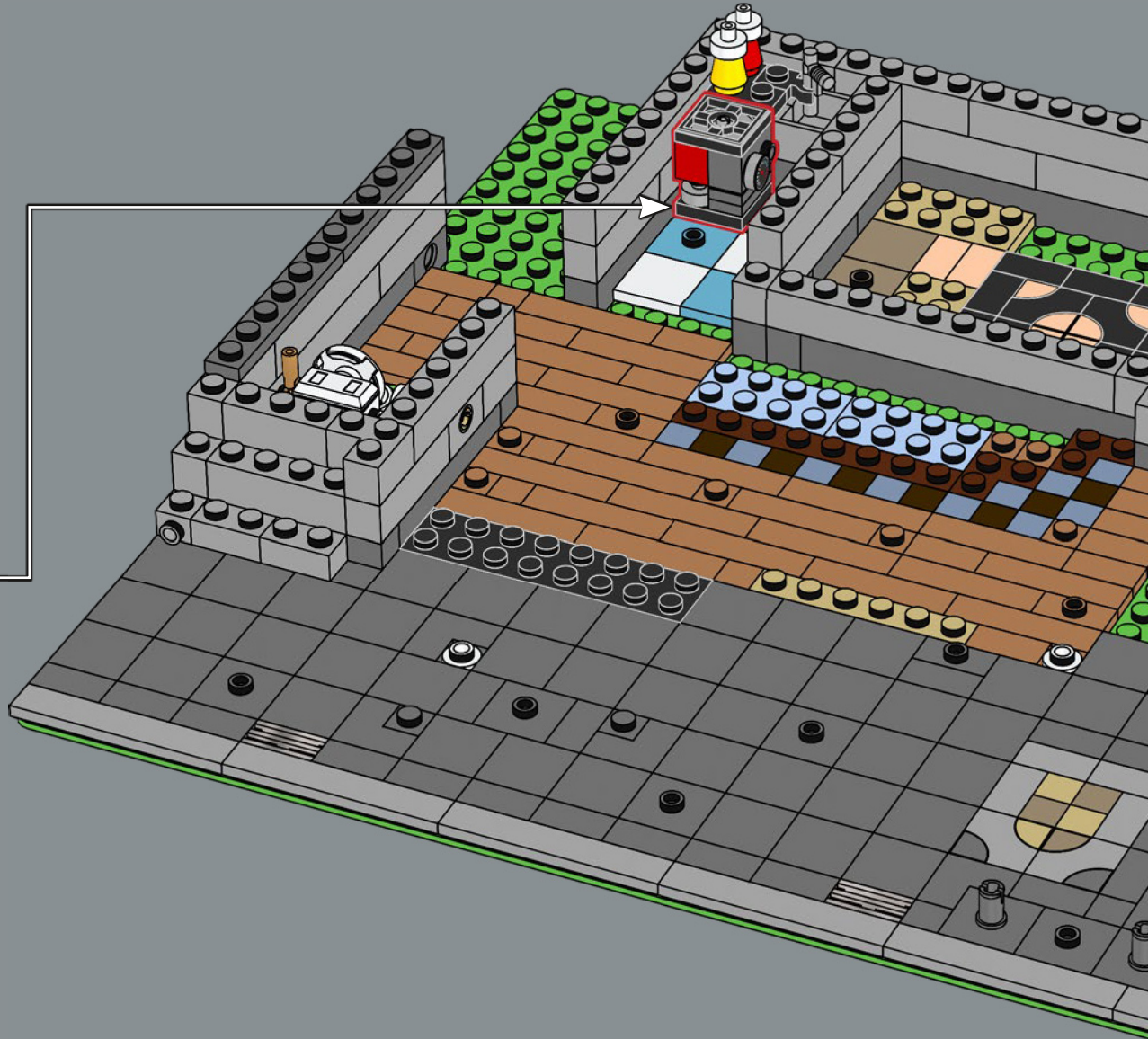
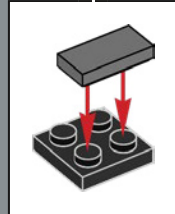
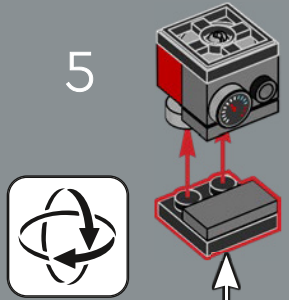
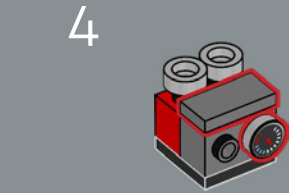
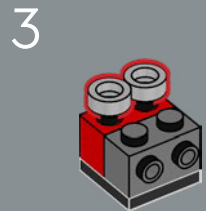
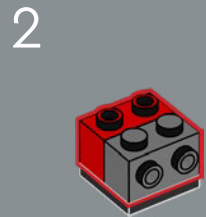
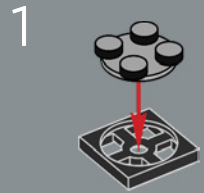

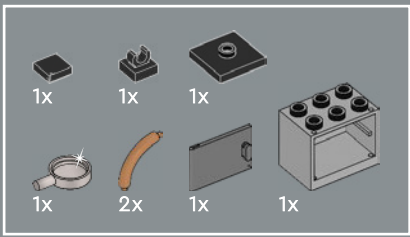

32

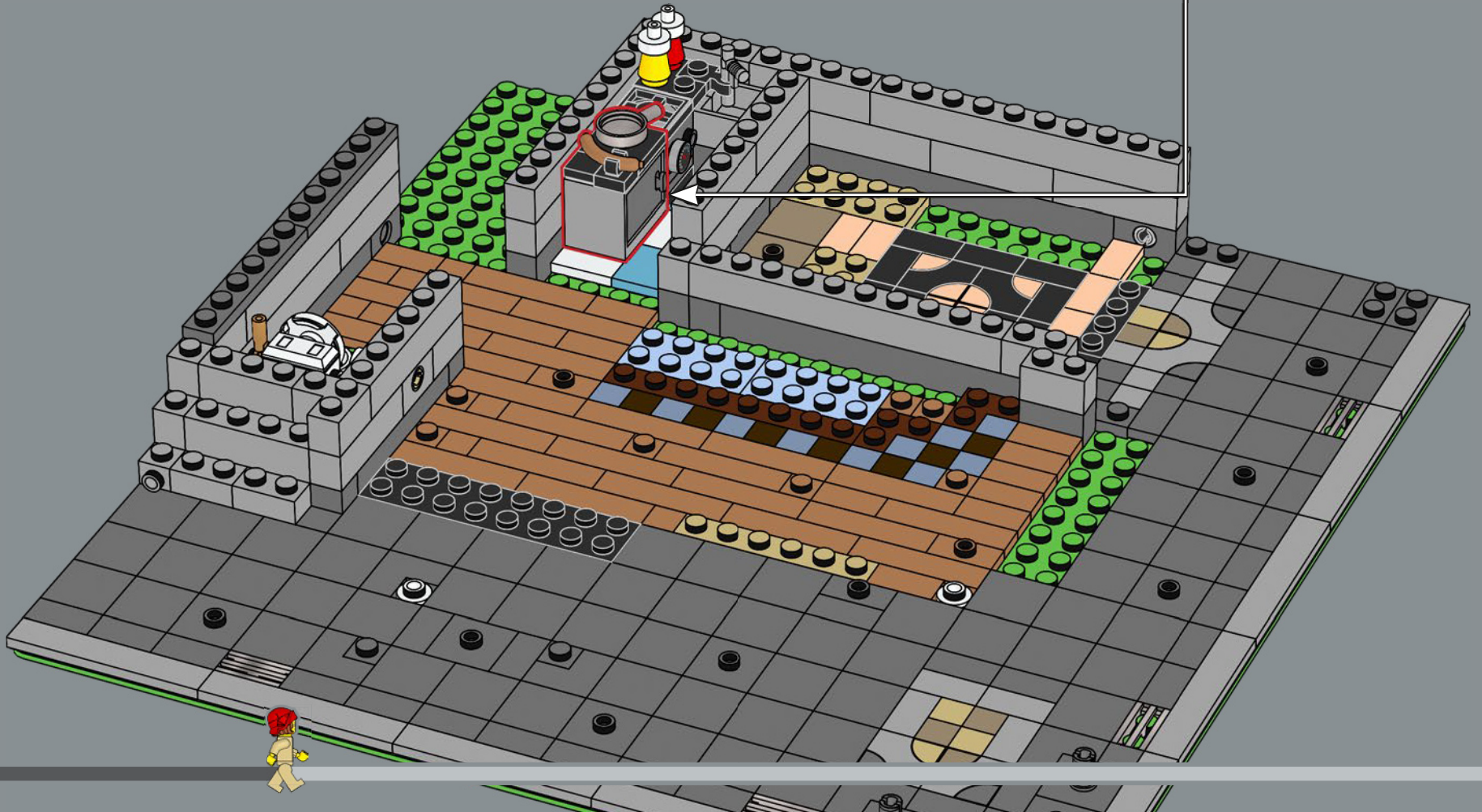
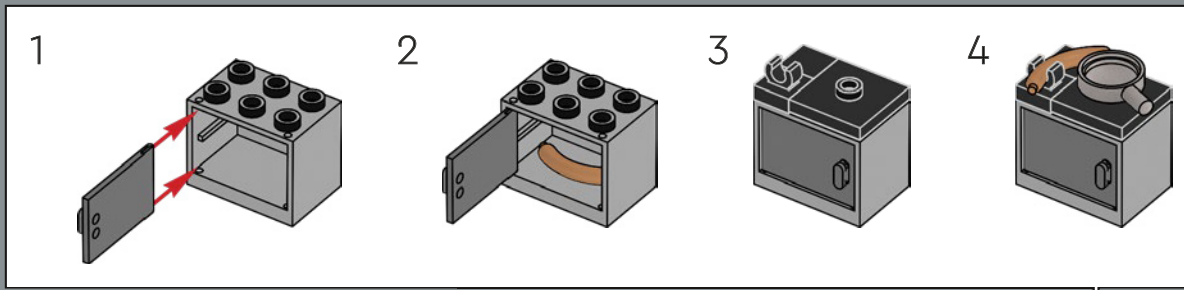



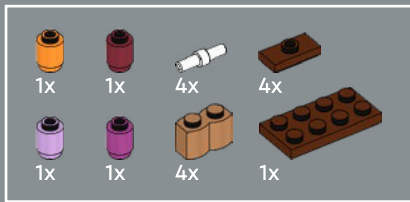

33

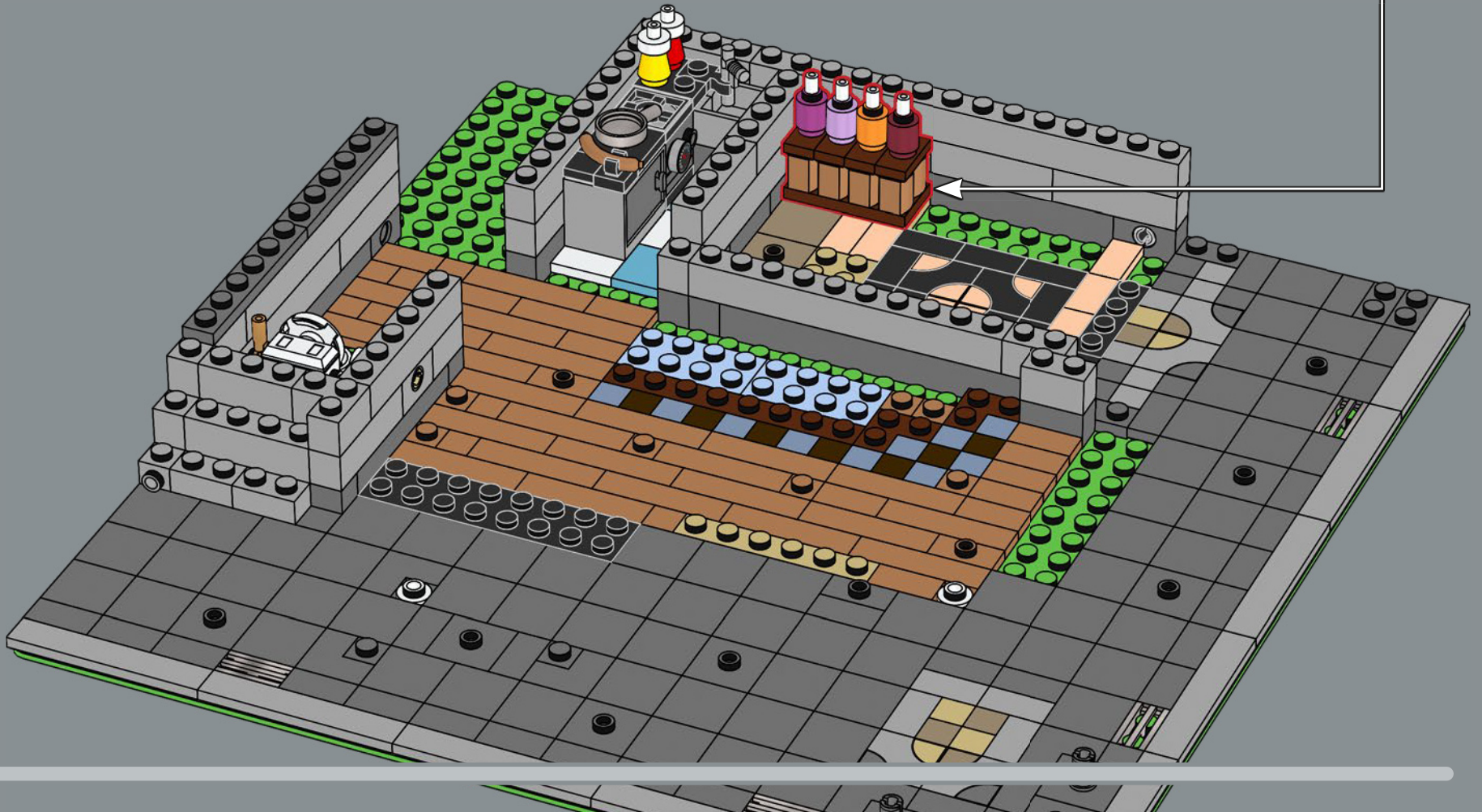
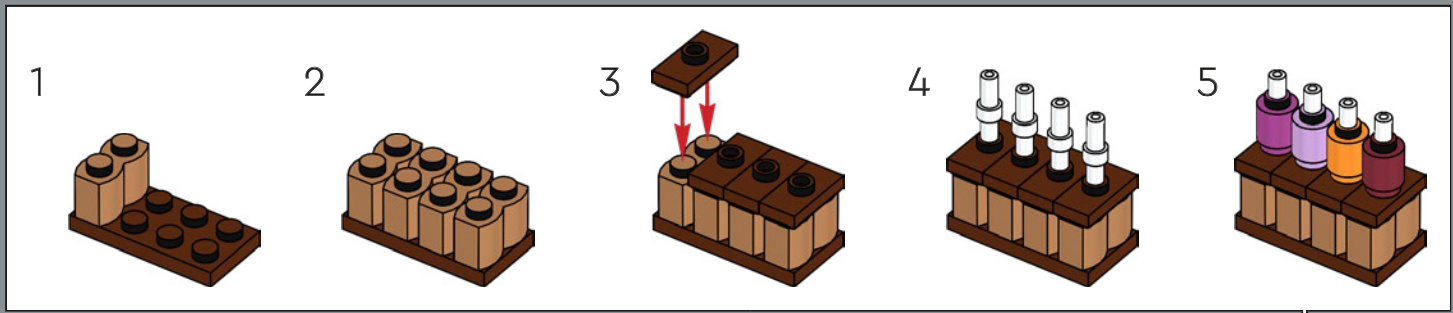

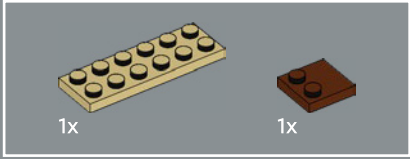

34

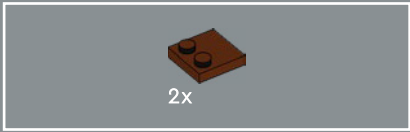
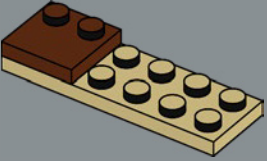

35

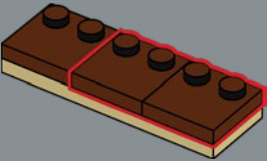

36

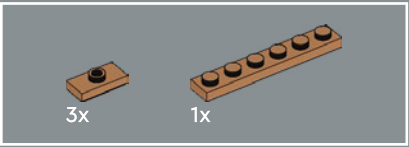
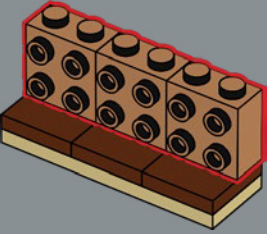

37

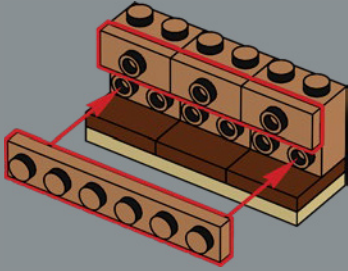

38

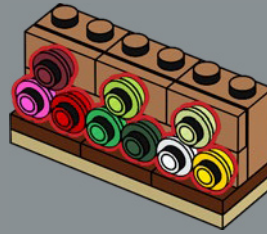

39

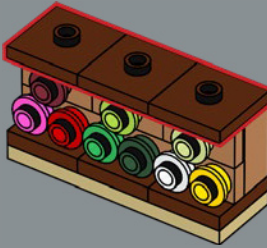



40

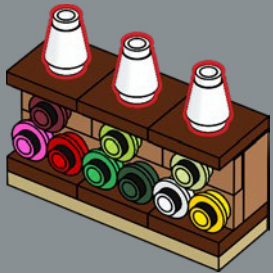

41



42



It is in this haberdashery that the tailor from LEGO® Icons Jazz Club (10312) obtains his supplies for many of his sumptuous creations.

C'est dans cette mercerie que le tailleur du club de jazz LEGO® Icons (10312) s'approvisionne pour nombre de ses somptueuses créations.

Es aquí, en esta mercería, donde el sastre del Club de Jazz LEGO® Icons (10312) obtiene los materiales para muchas de sus lujosas creaciones.

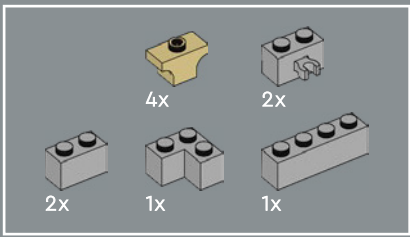

43



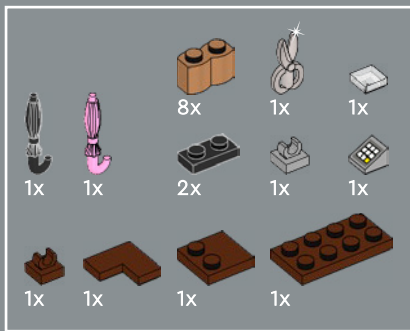

44

1

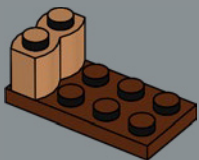

2

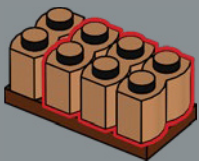

3

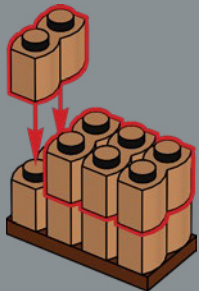

4

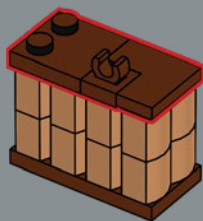

5

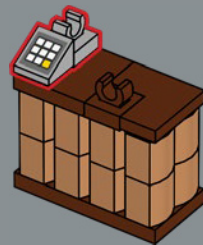

6



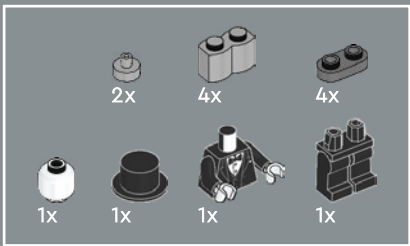

45

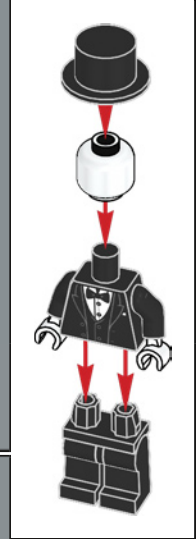
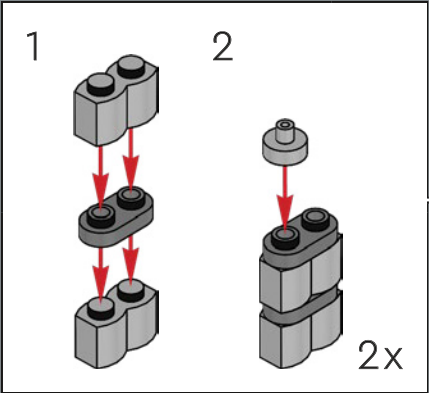

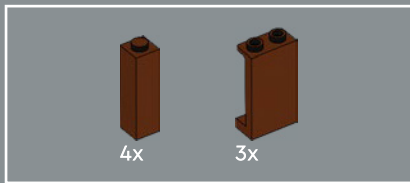

46



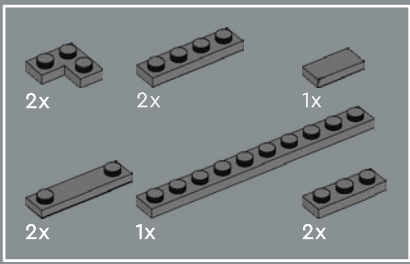

47





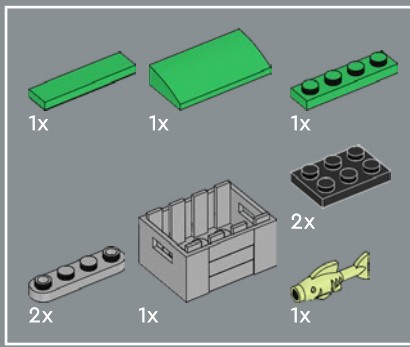

48

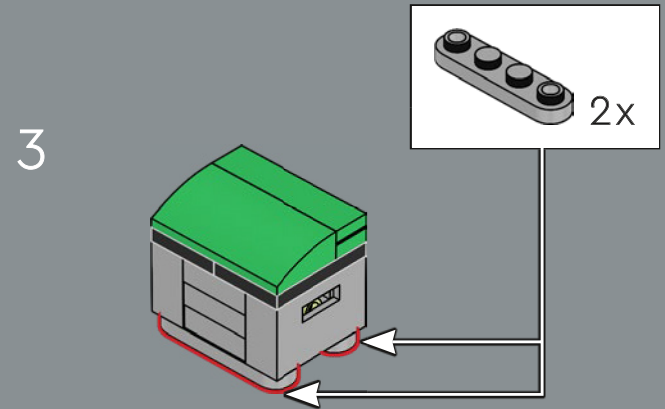
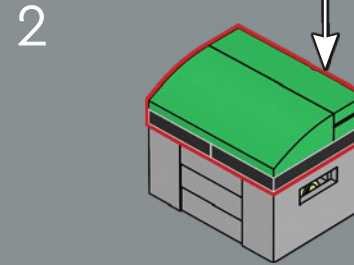
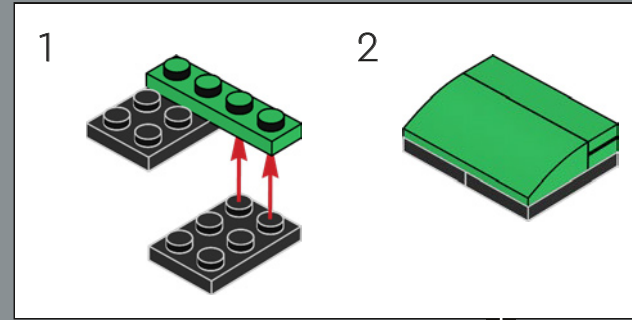
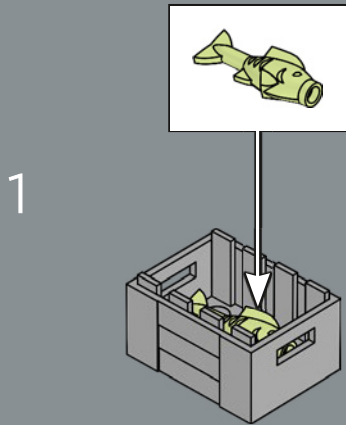



Although this fish might not be fresh from the kitchen, the local kittens are very excited to get a free meal!

Même si ce poisson n'est pas fraîchement sorti de la cuisine, les chatons du quartier sont très heureux d'avoir un repas gratuit !

Aunque este pescado no esté recién salido de la cocina, ¡a los gatitos locales les encanta recibir comida gratis!



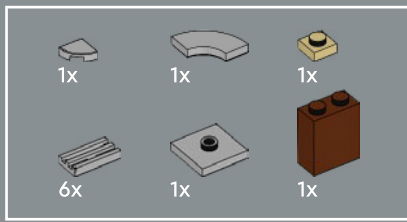

49

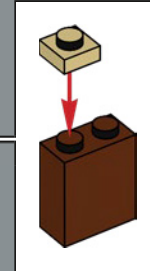

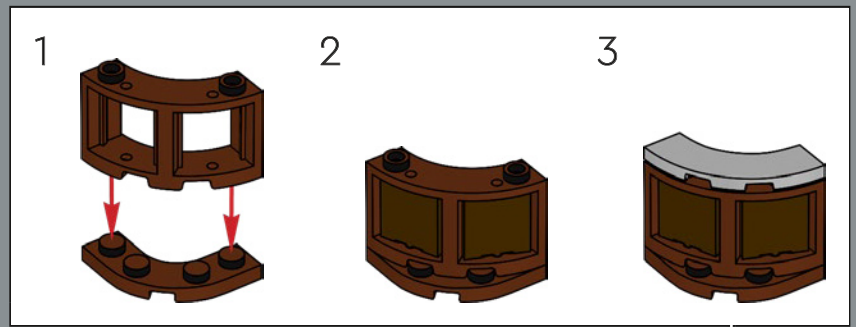
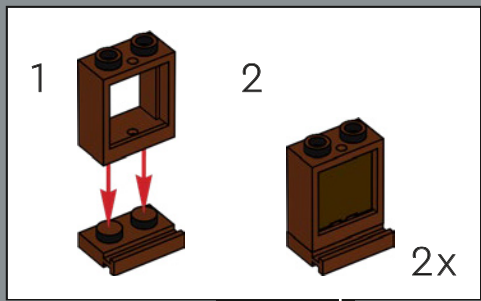
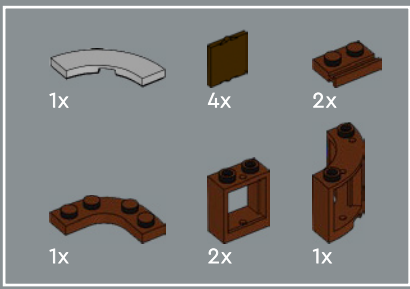

50

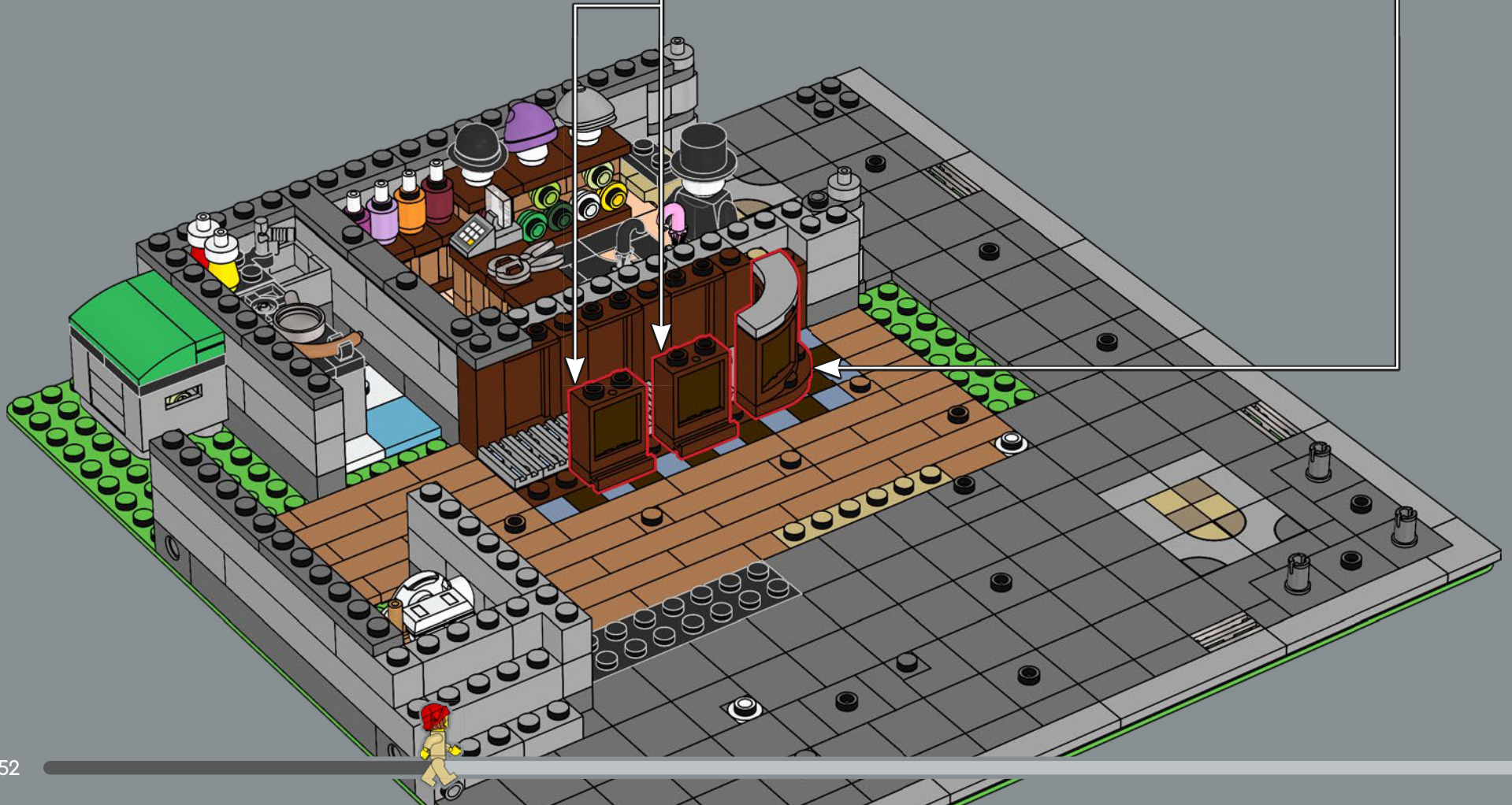

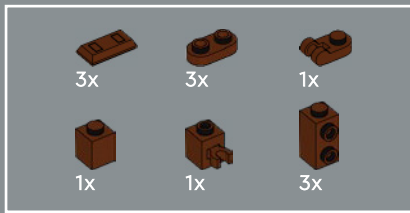

51

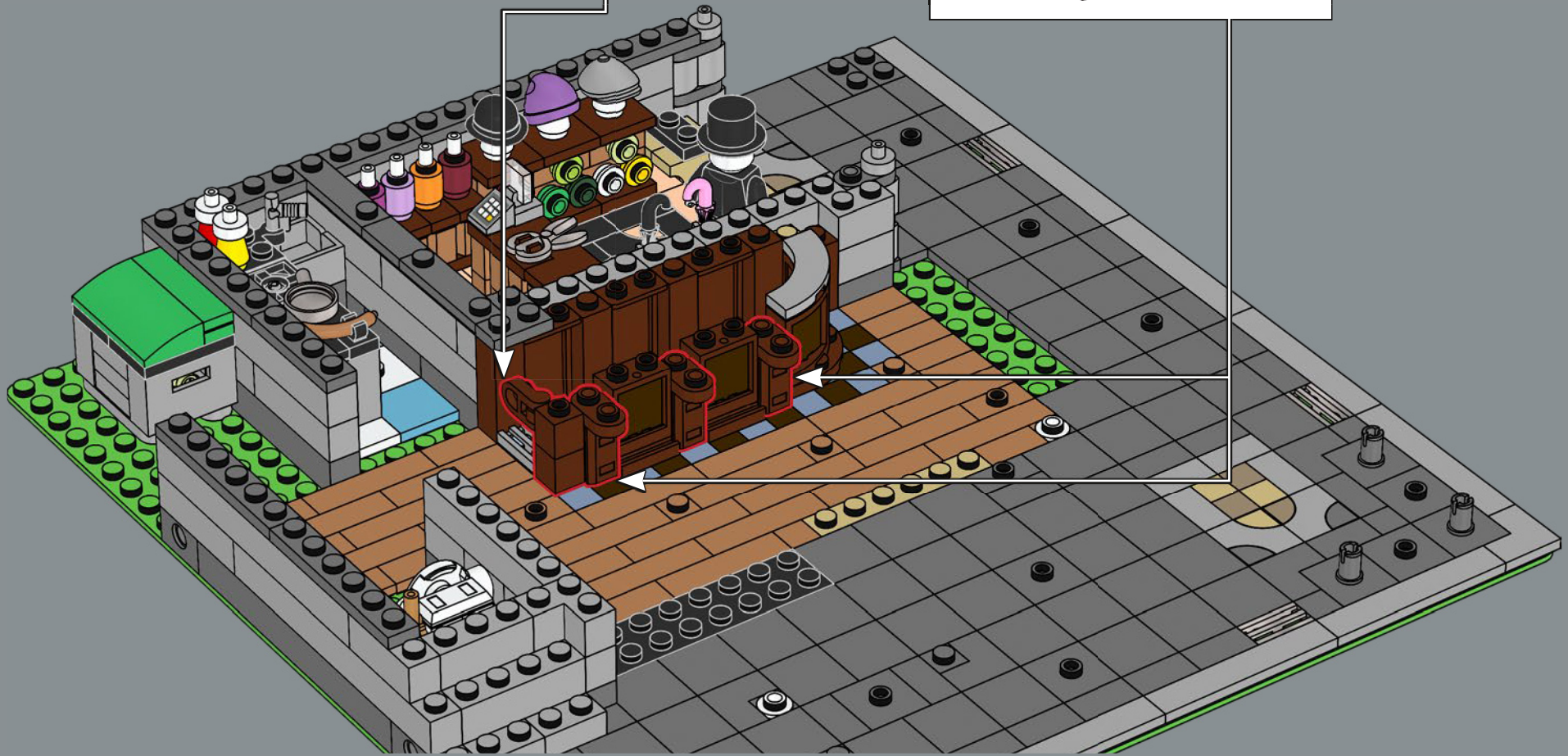
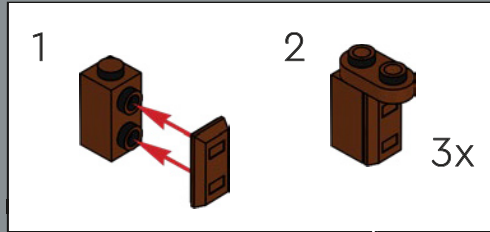
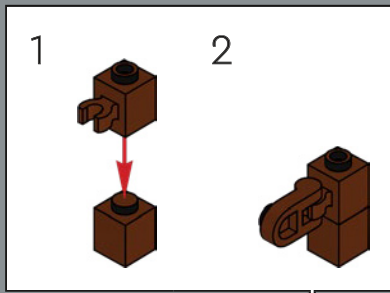

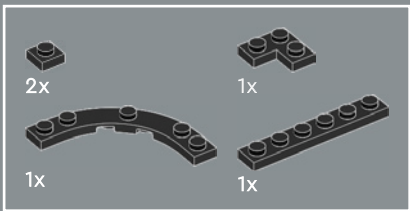

52



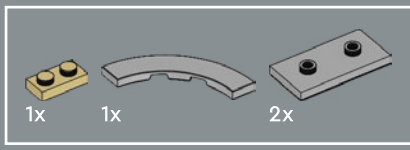

53

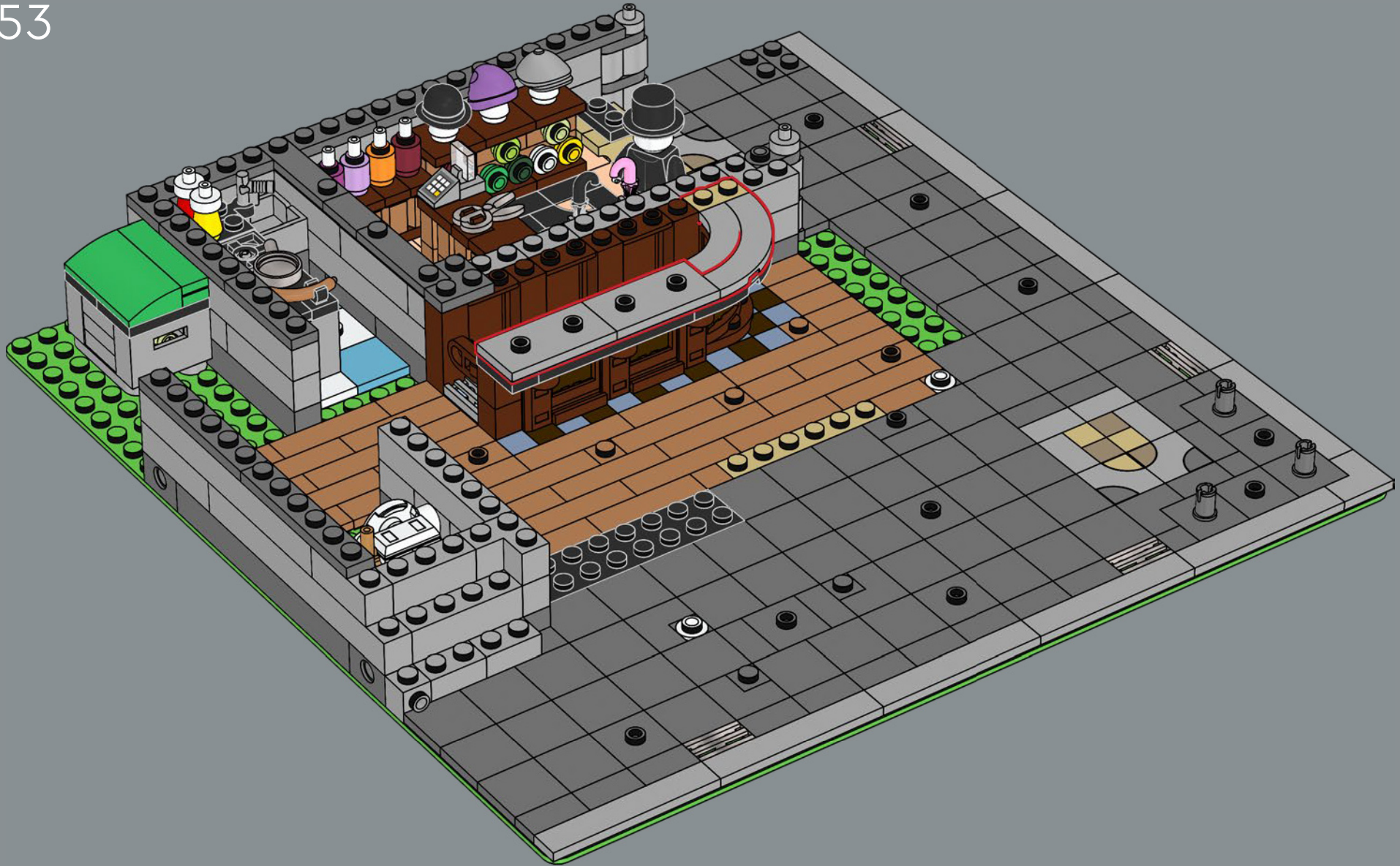

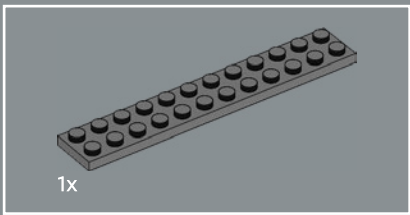

54





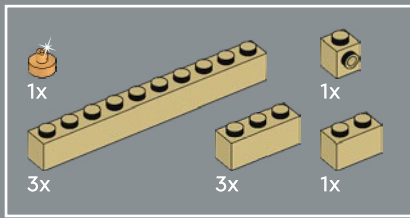

55

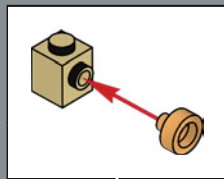

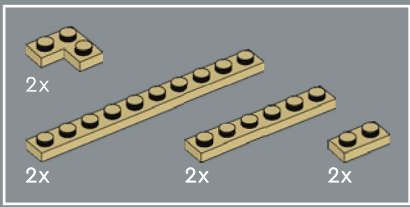

56



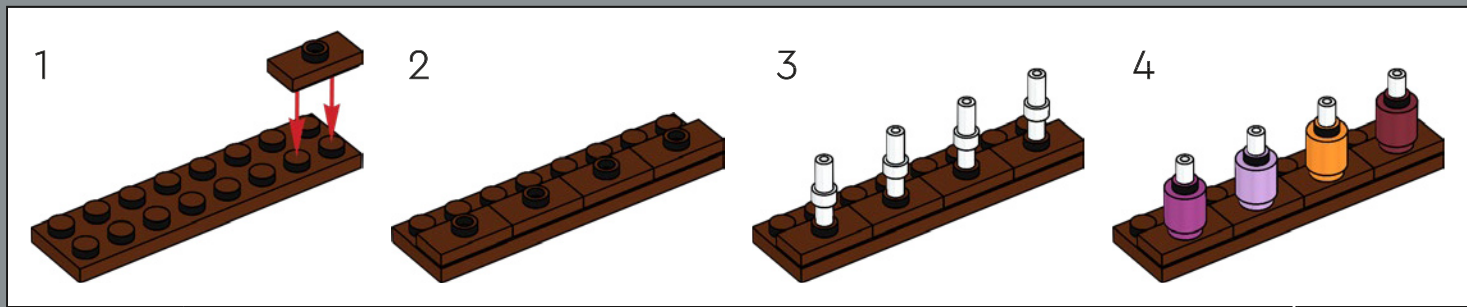
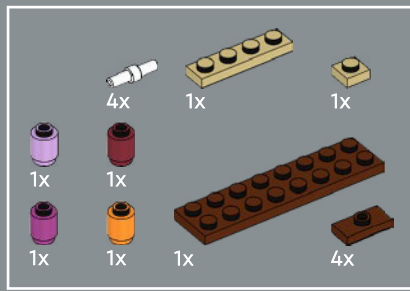

57

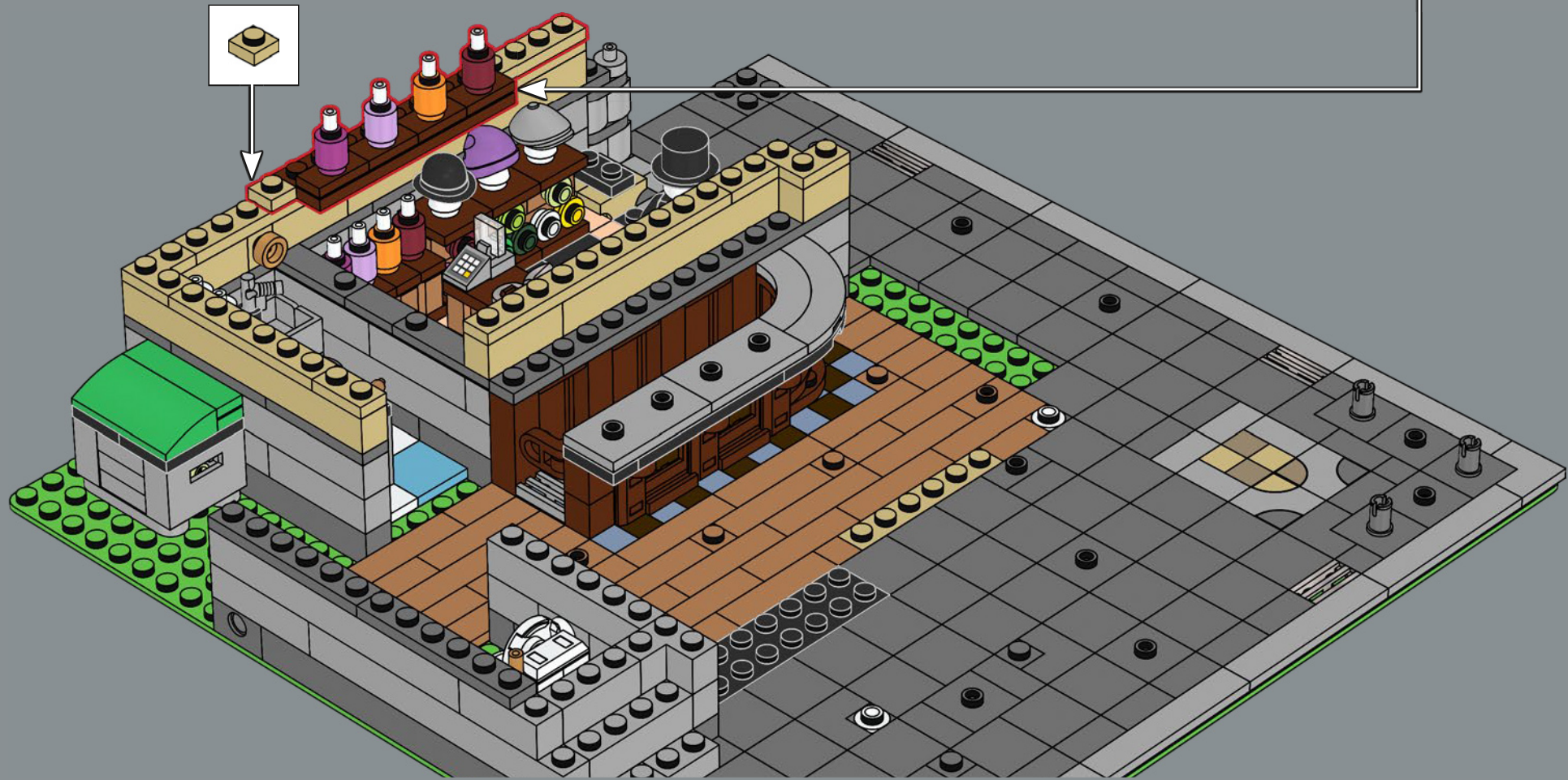

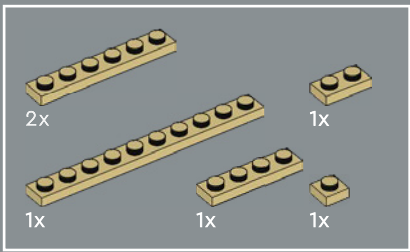

58



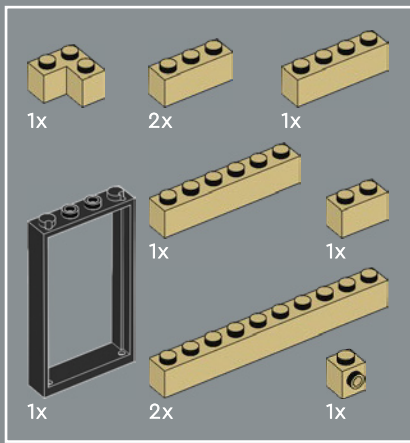

59

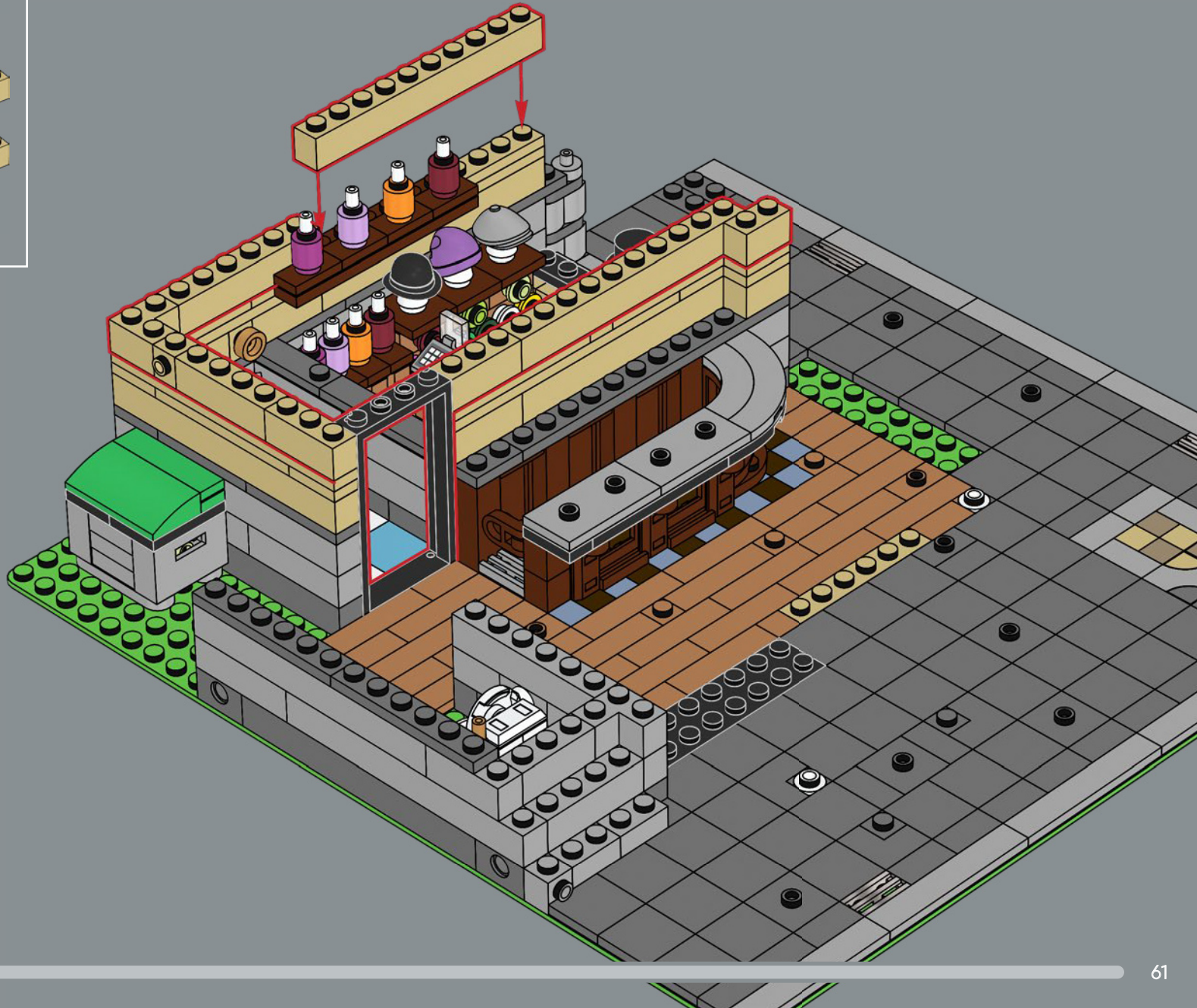

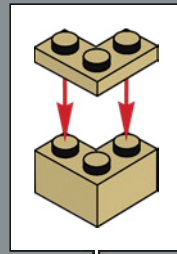
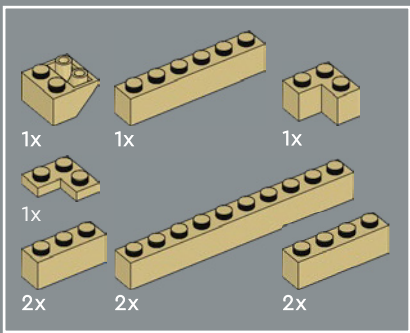

60



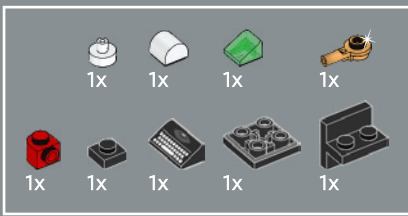

61

1

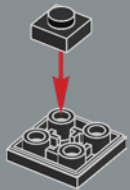

2



3



4



5

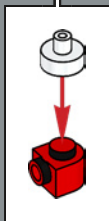



62

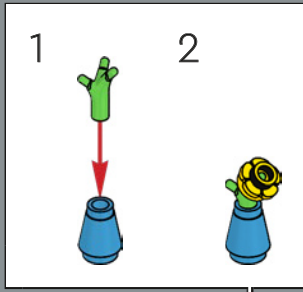
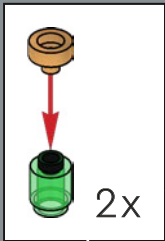





63

1

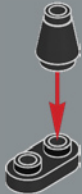

2



3

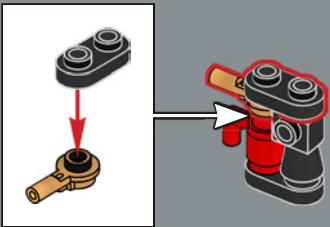

4





64

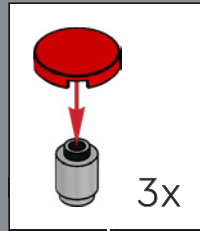
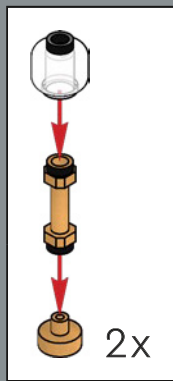
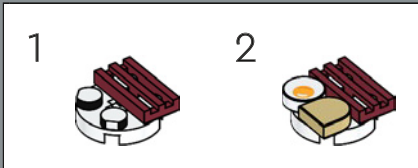

This gigantic, richly decorated counter is as old as the building itself. The perfect corner to drink your coffee (according to the owner!).

Ce gigantesque comptoir richement décoré est aussi vieux que le bâtiment lui-même. Le coin idéal pour boire son café (selon la propriétaire!).

Este viejo mostrador, ricamente decorado, es tan antiguo como el edificio mismo. El rincón perfecto para disfrutar de un café (según el dueño!).



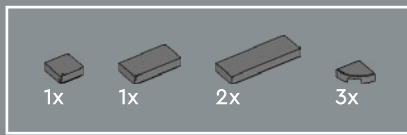

65



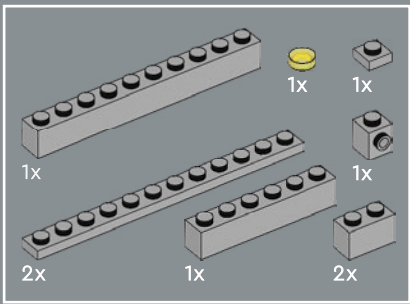

66

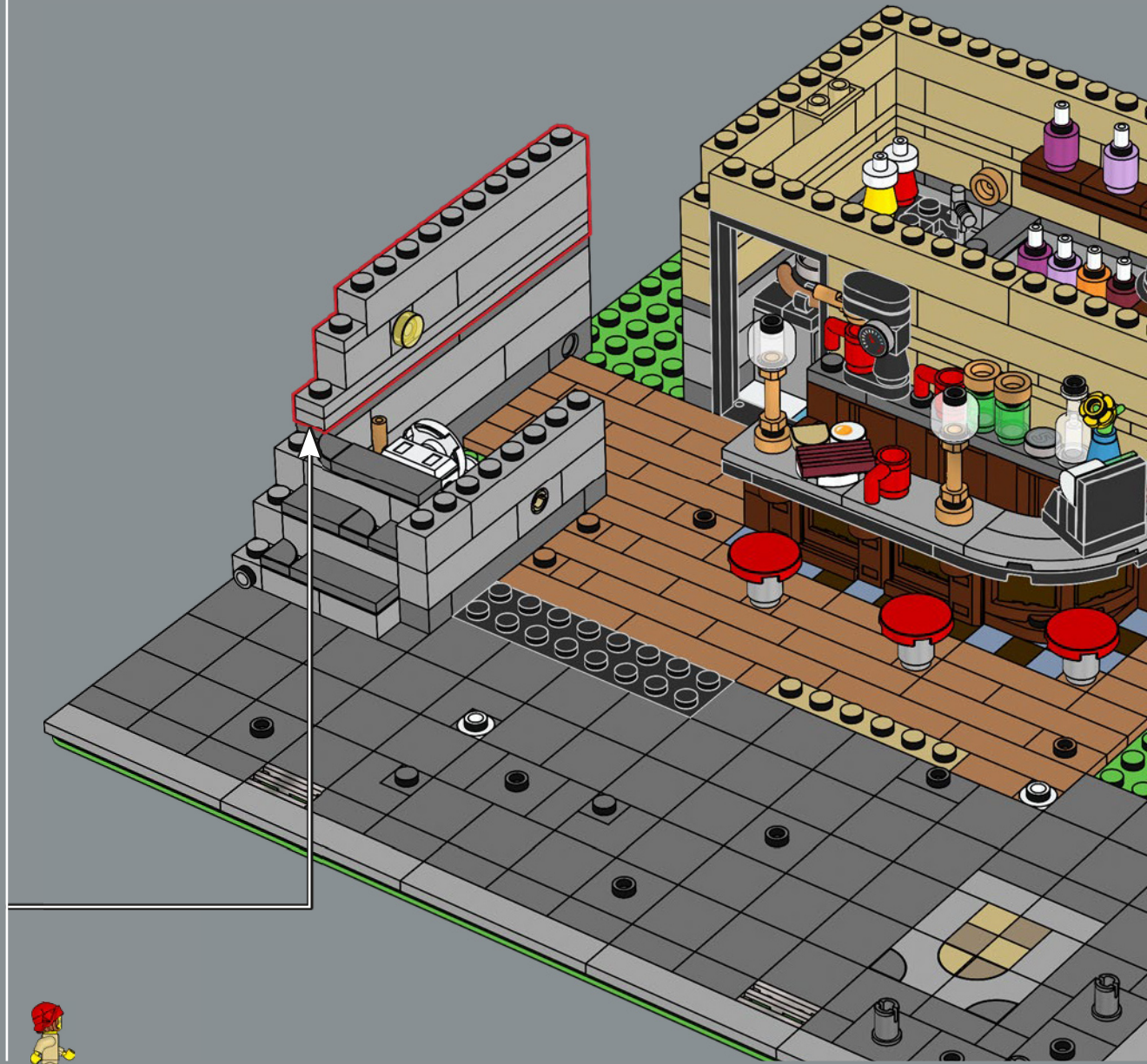
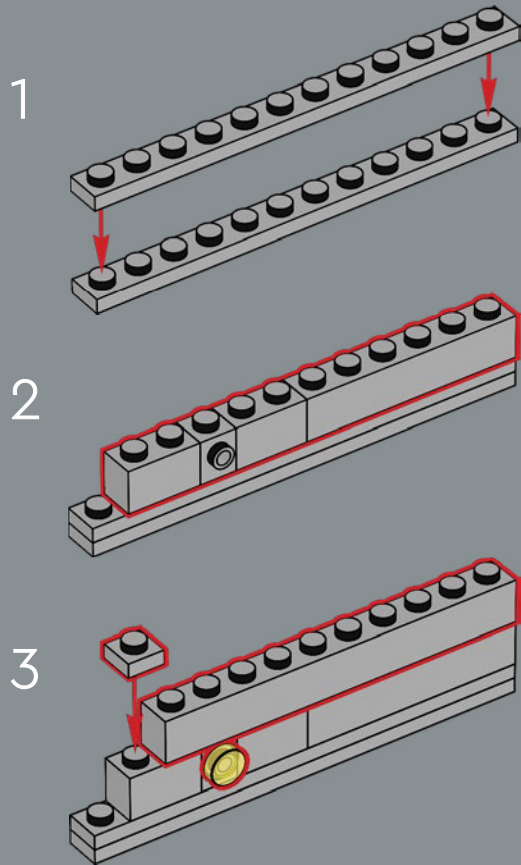

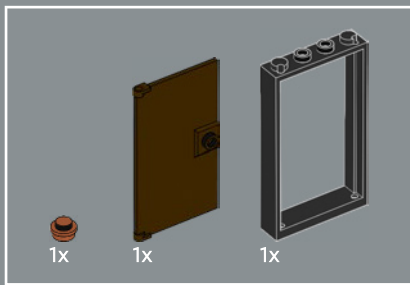

67

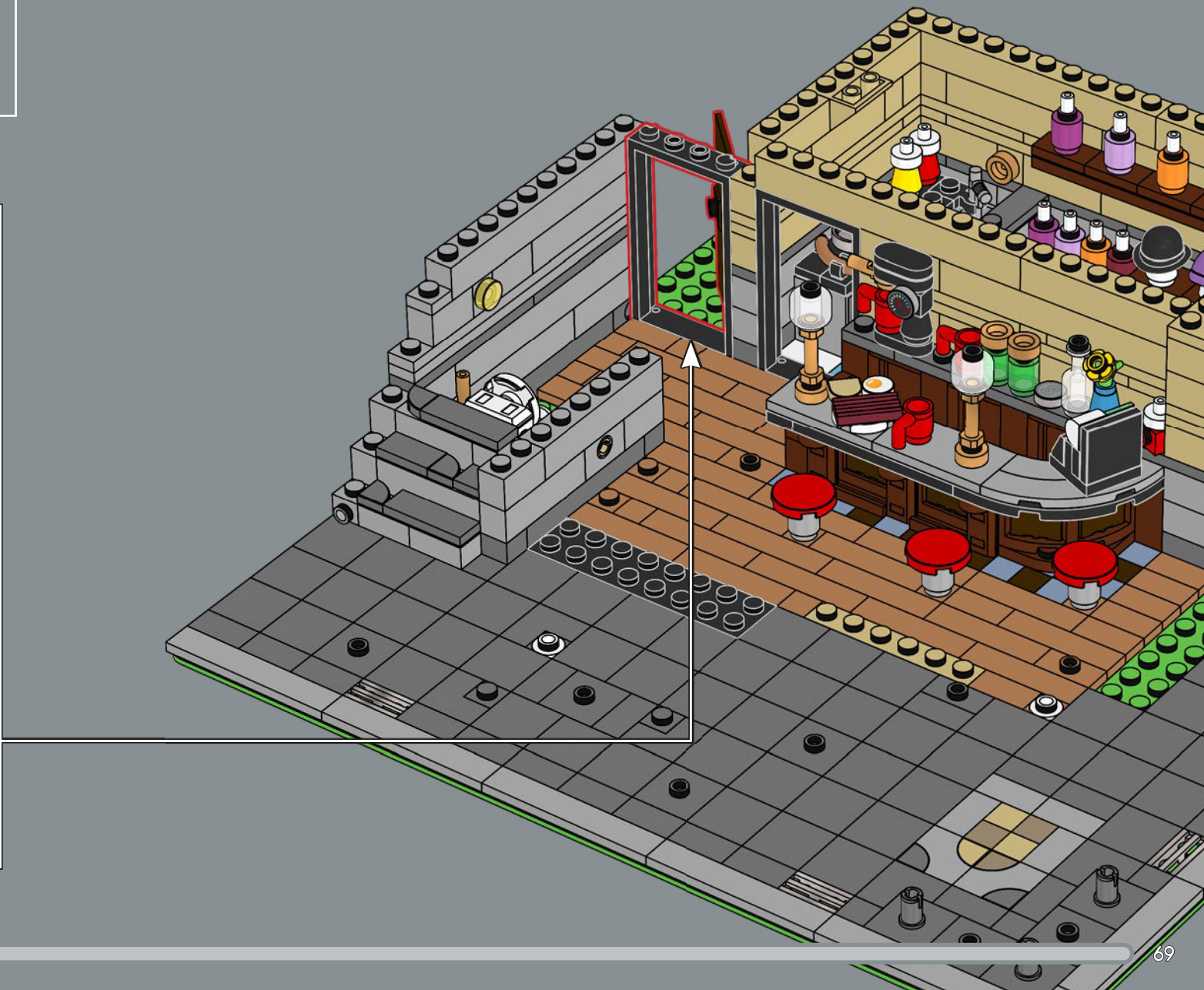
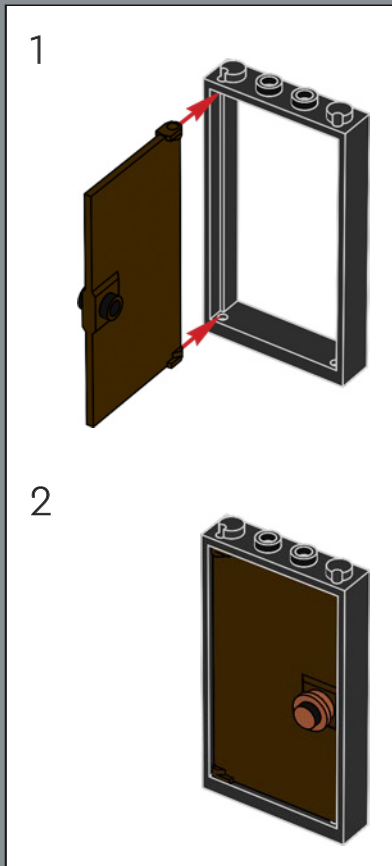

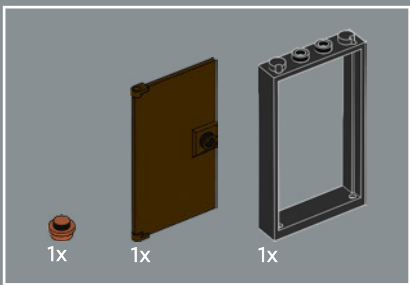

68

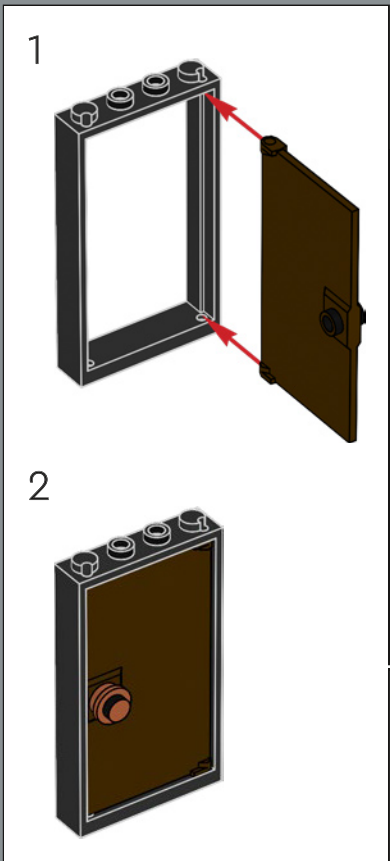

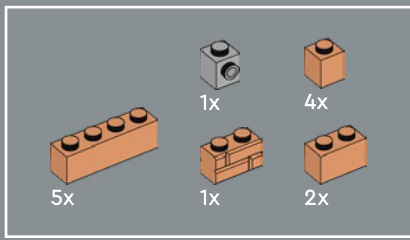

69

1

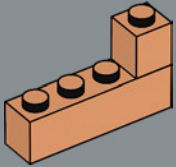

2

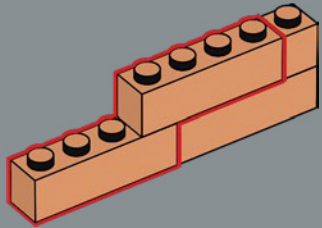

3

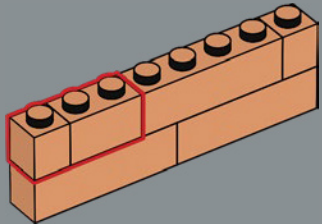

4

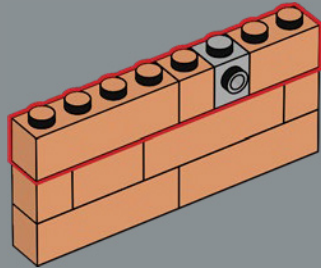

5

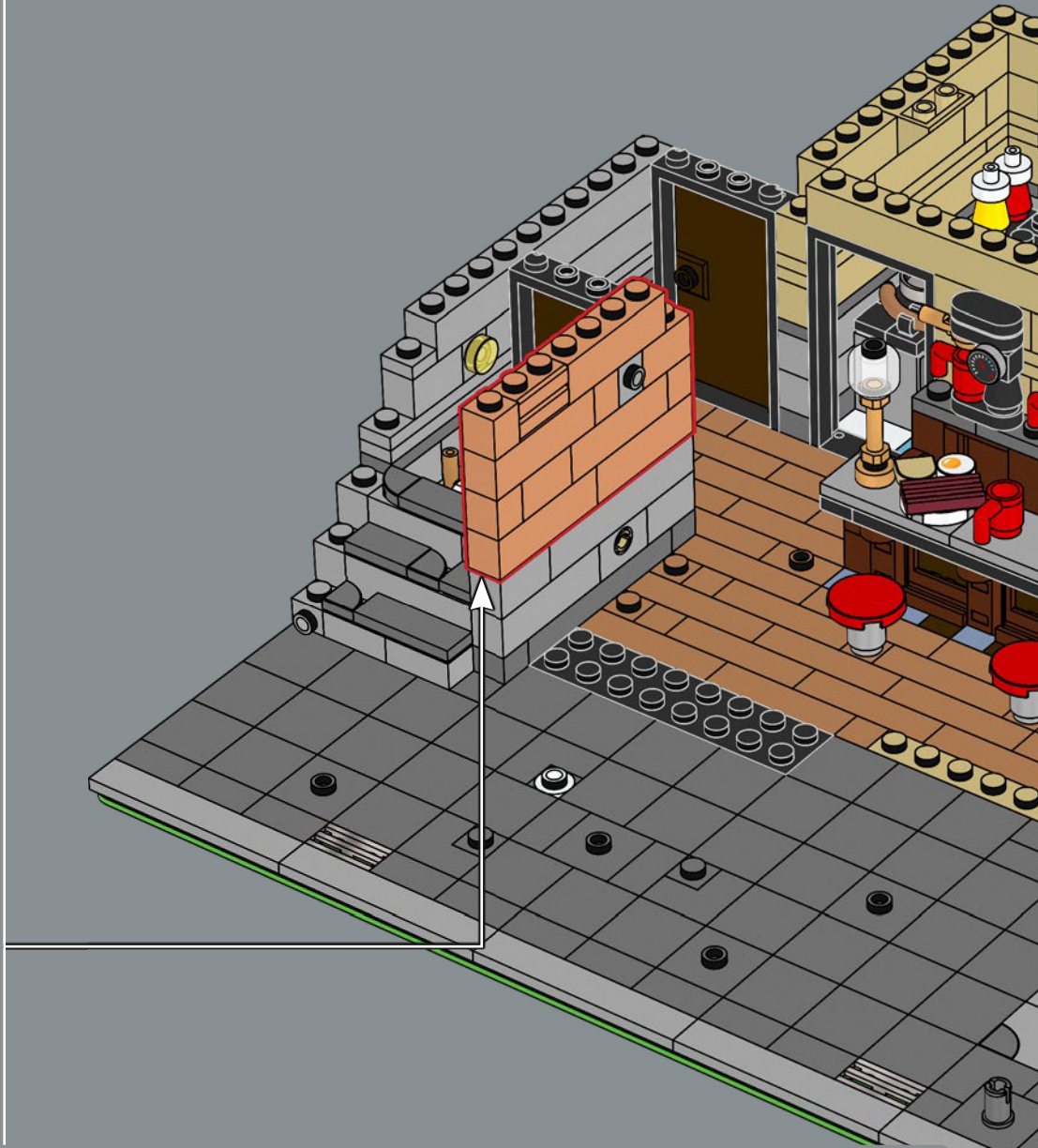
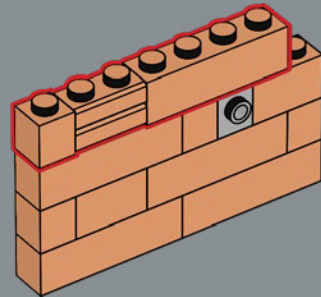

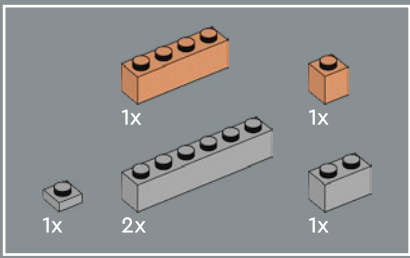

70





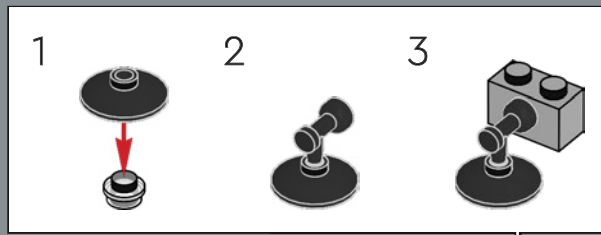
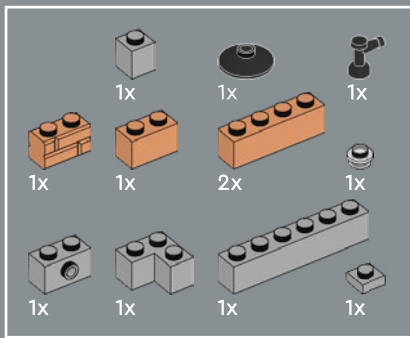

71



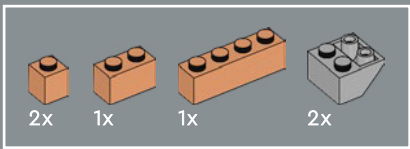

72



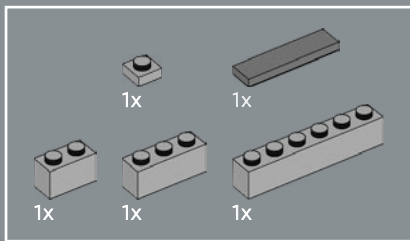

73



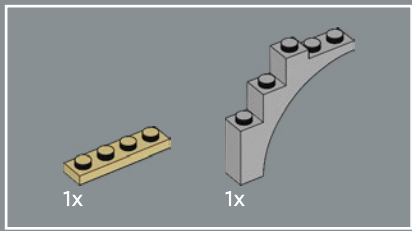

74

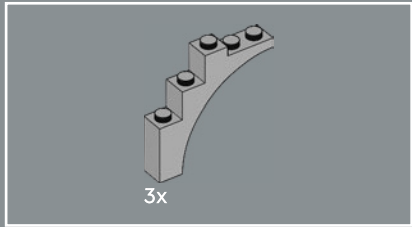
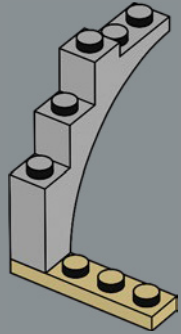

75

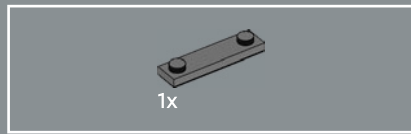
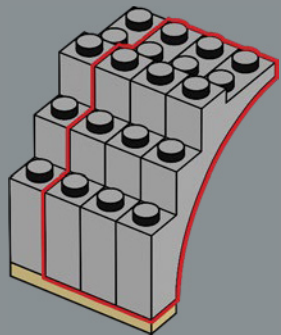

76

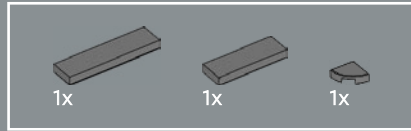
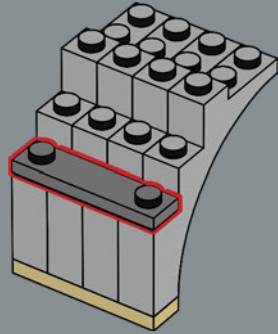

77

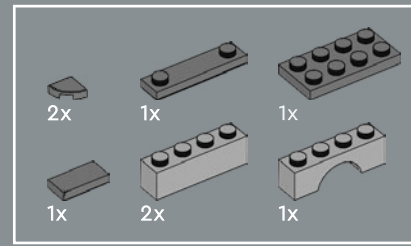
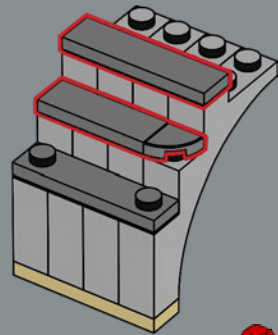

78

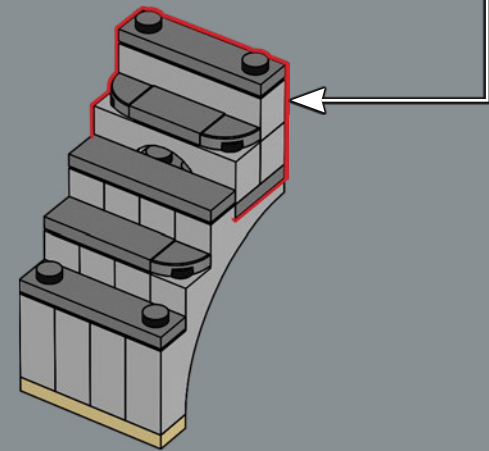
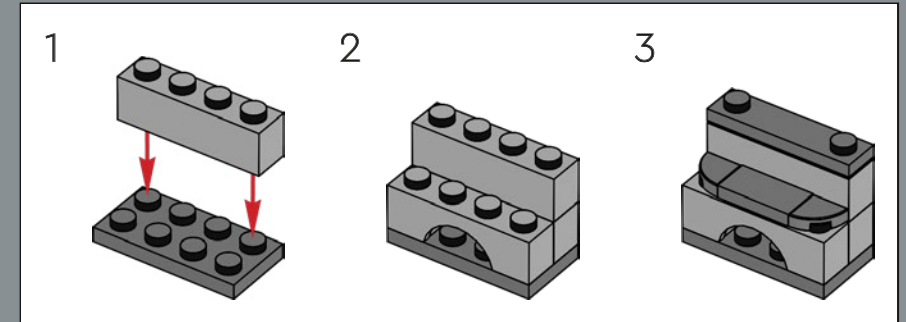



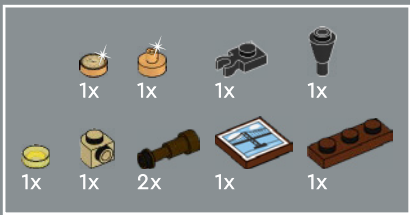

80

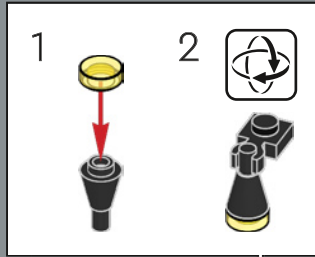
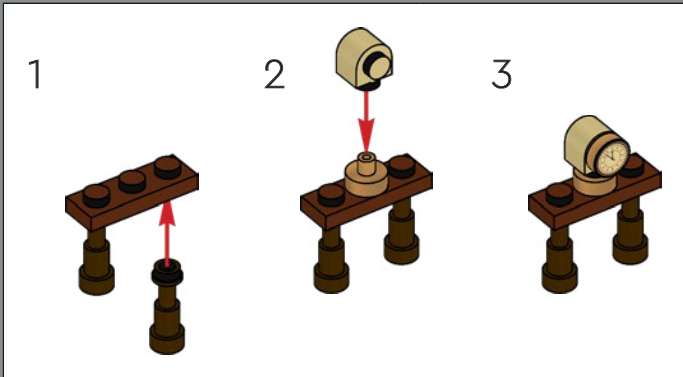

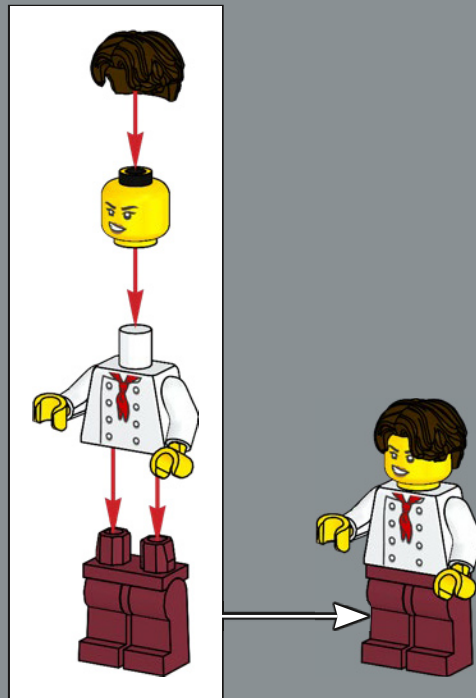

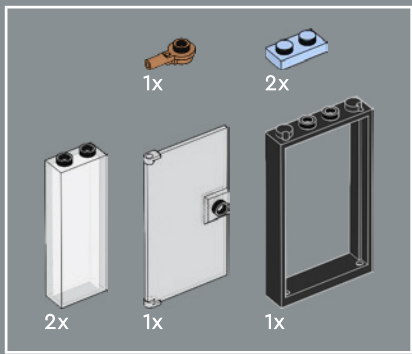

81

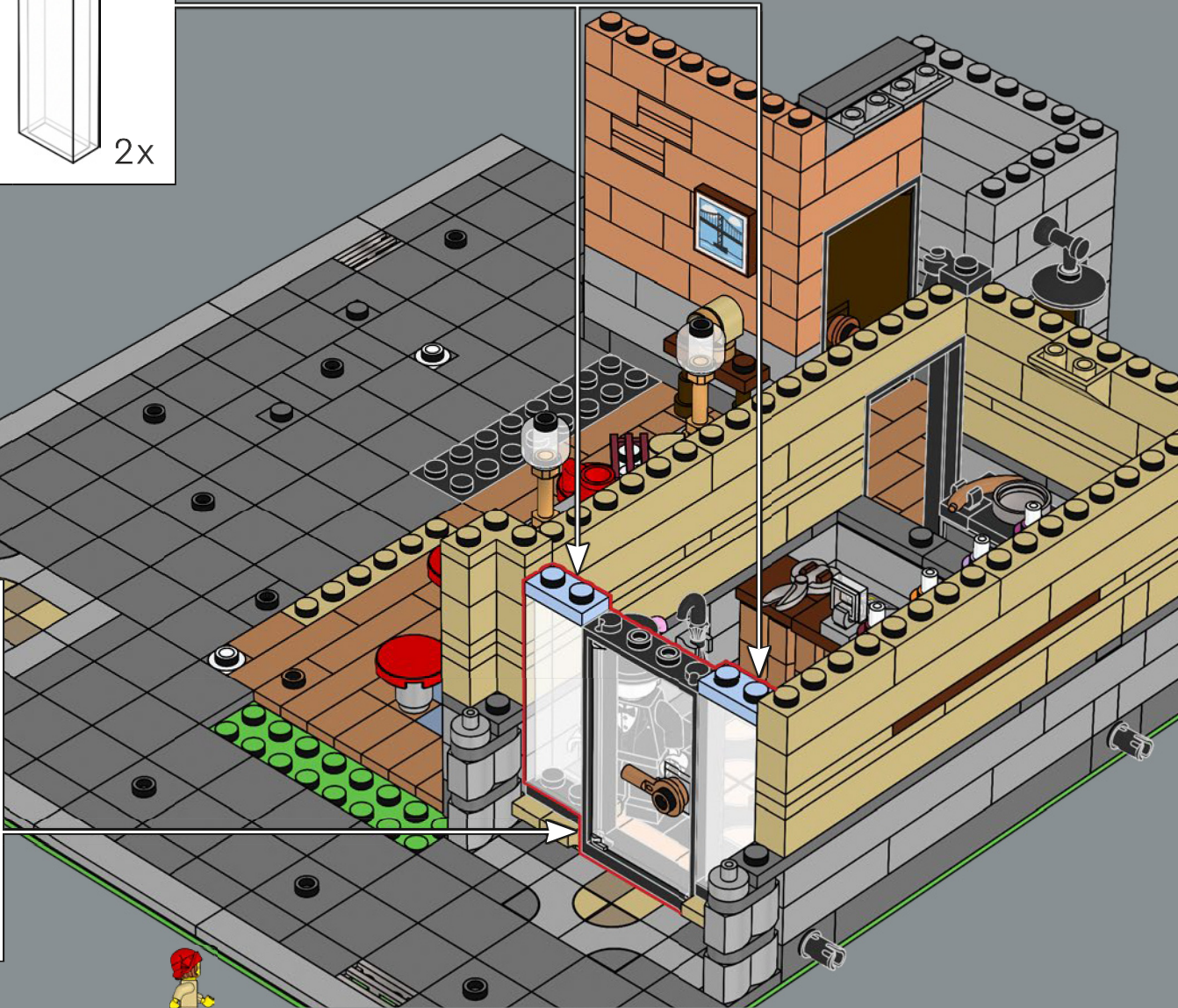
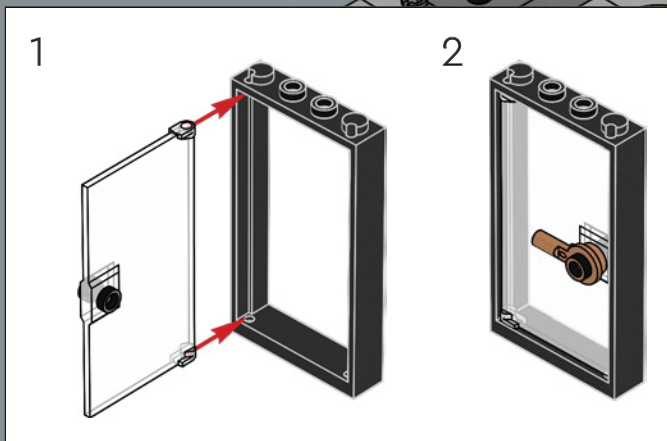
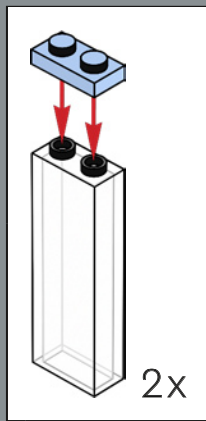



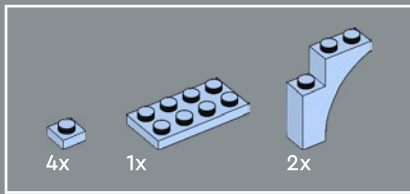

82

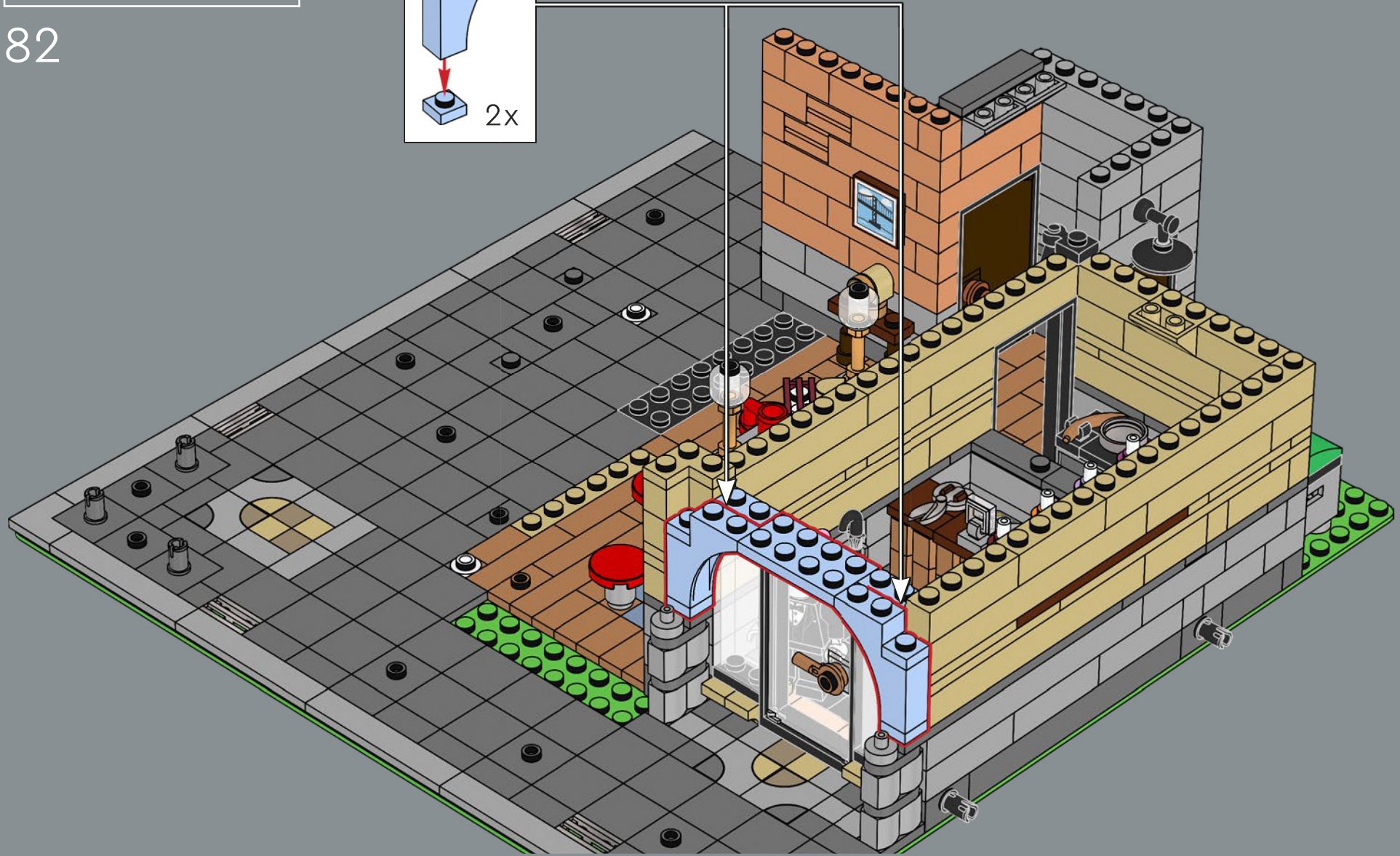
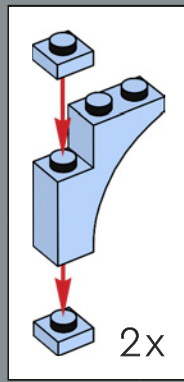

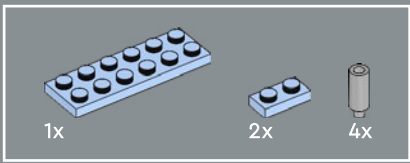

83

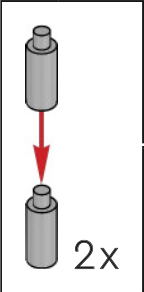

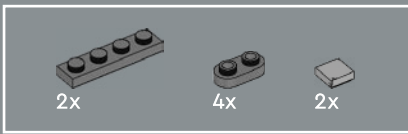

84

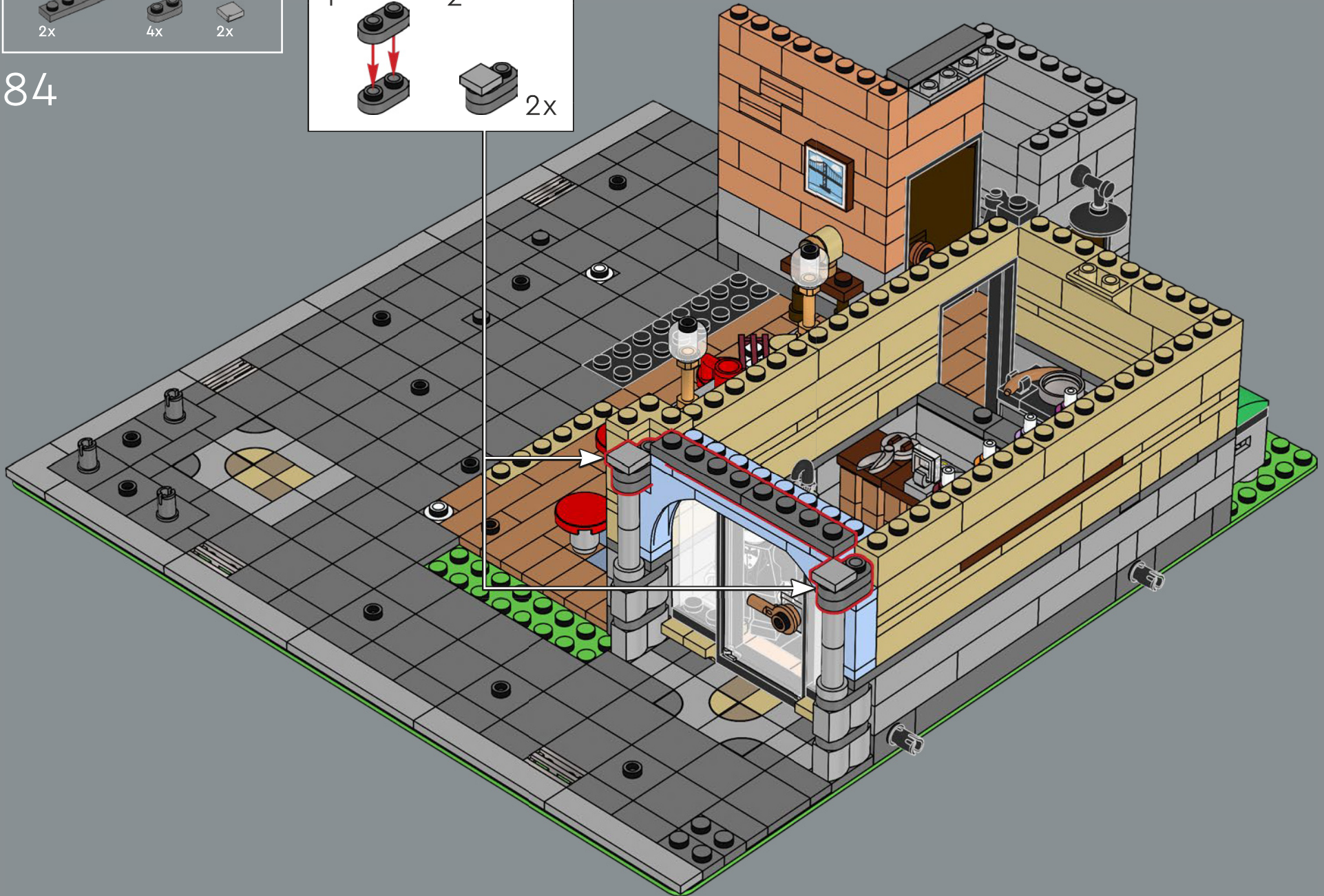
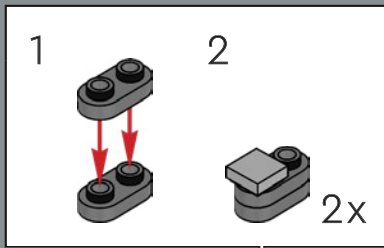

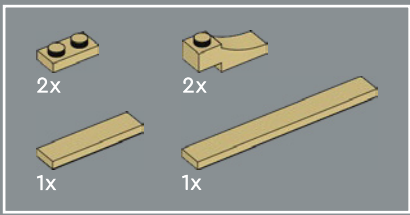

85

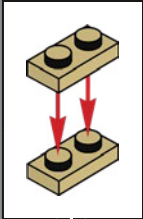

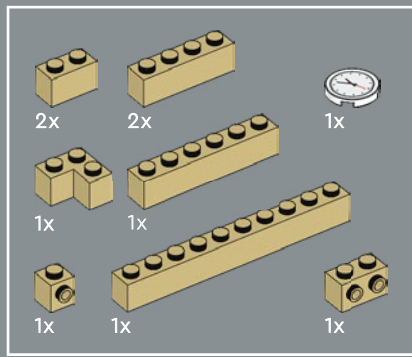

86

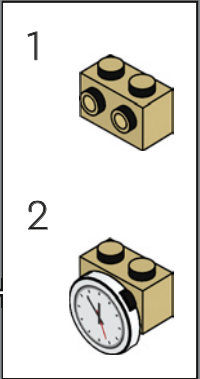
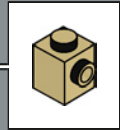
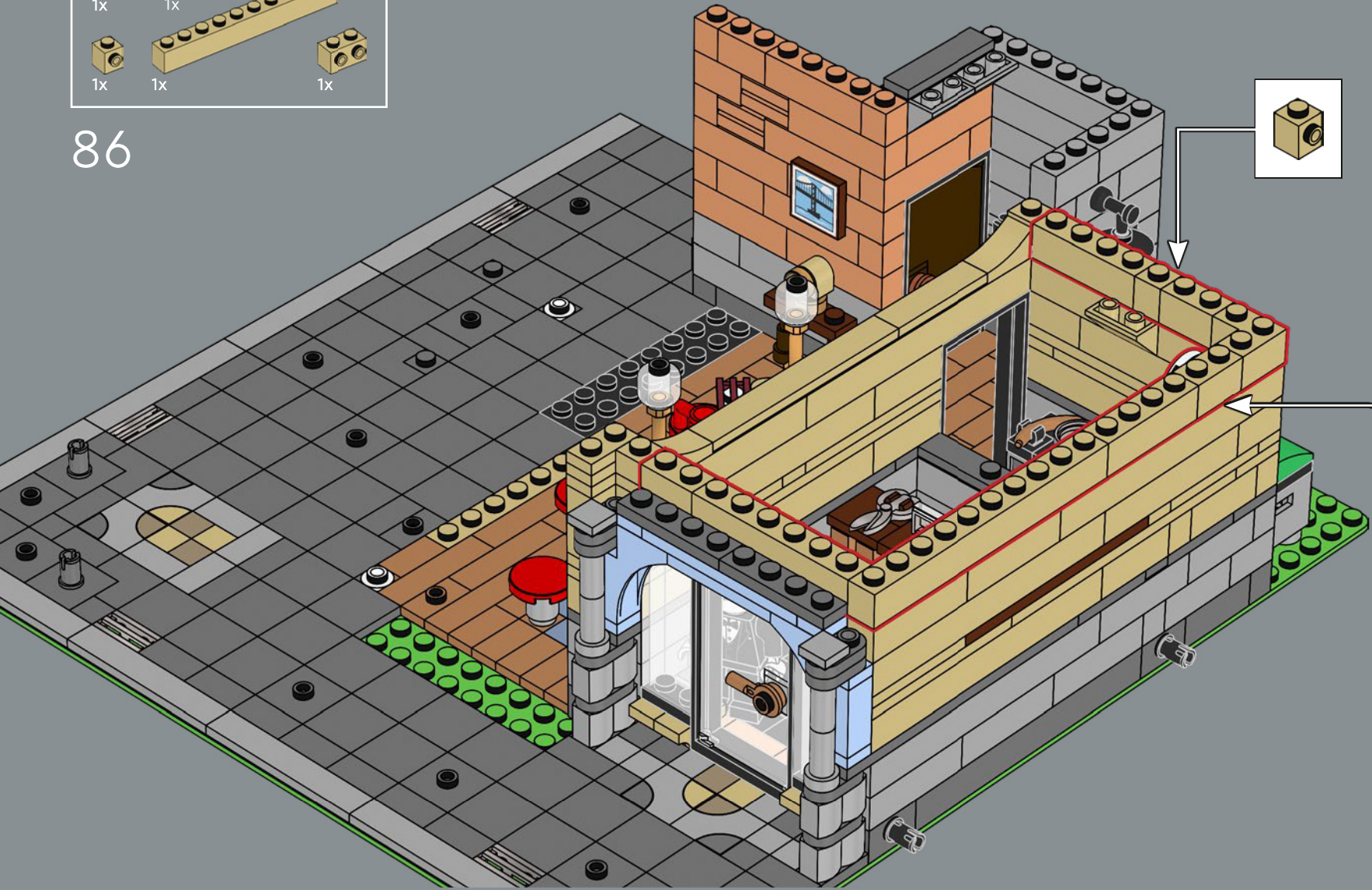

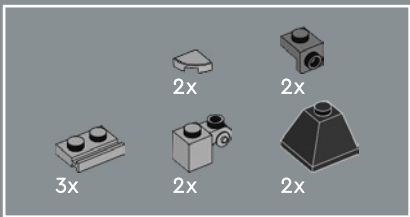

87

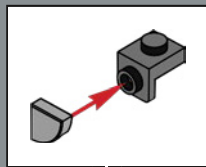

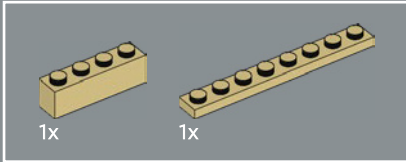
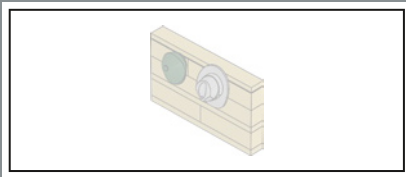

88

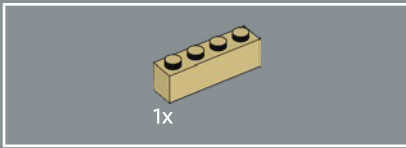
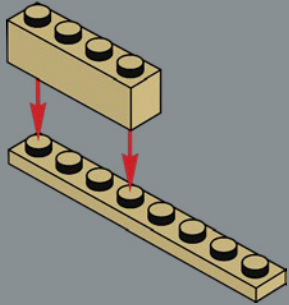

89

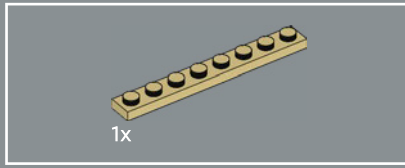
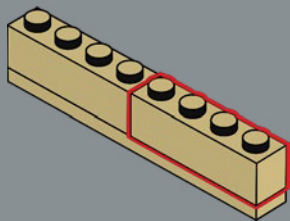

90

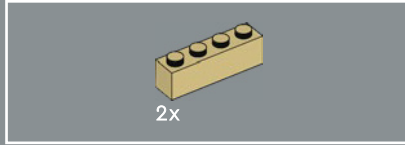
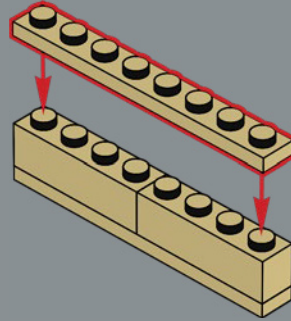

91

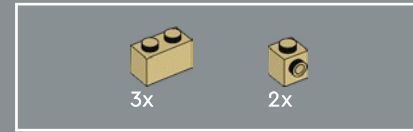
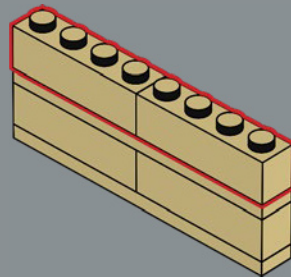

92

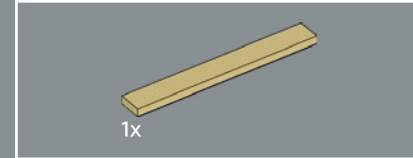
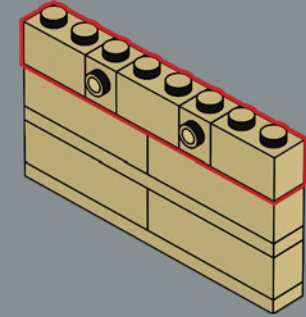

93

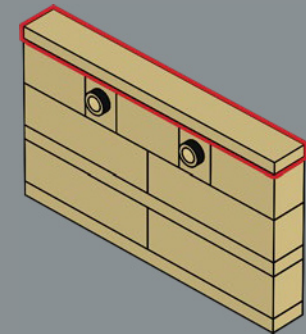



4x

94

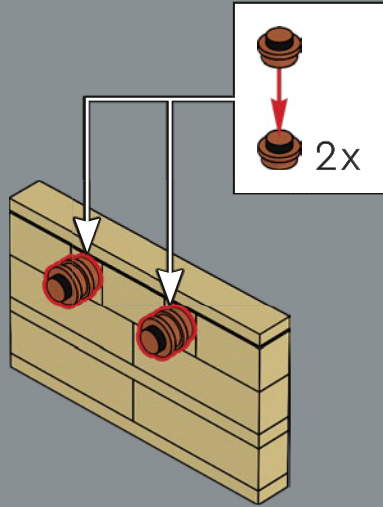

1x



1x

95

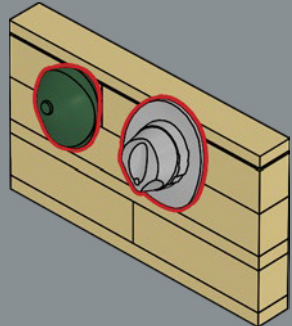

96

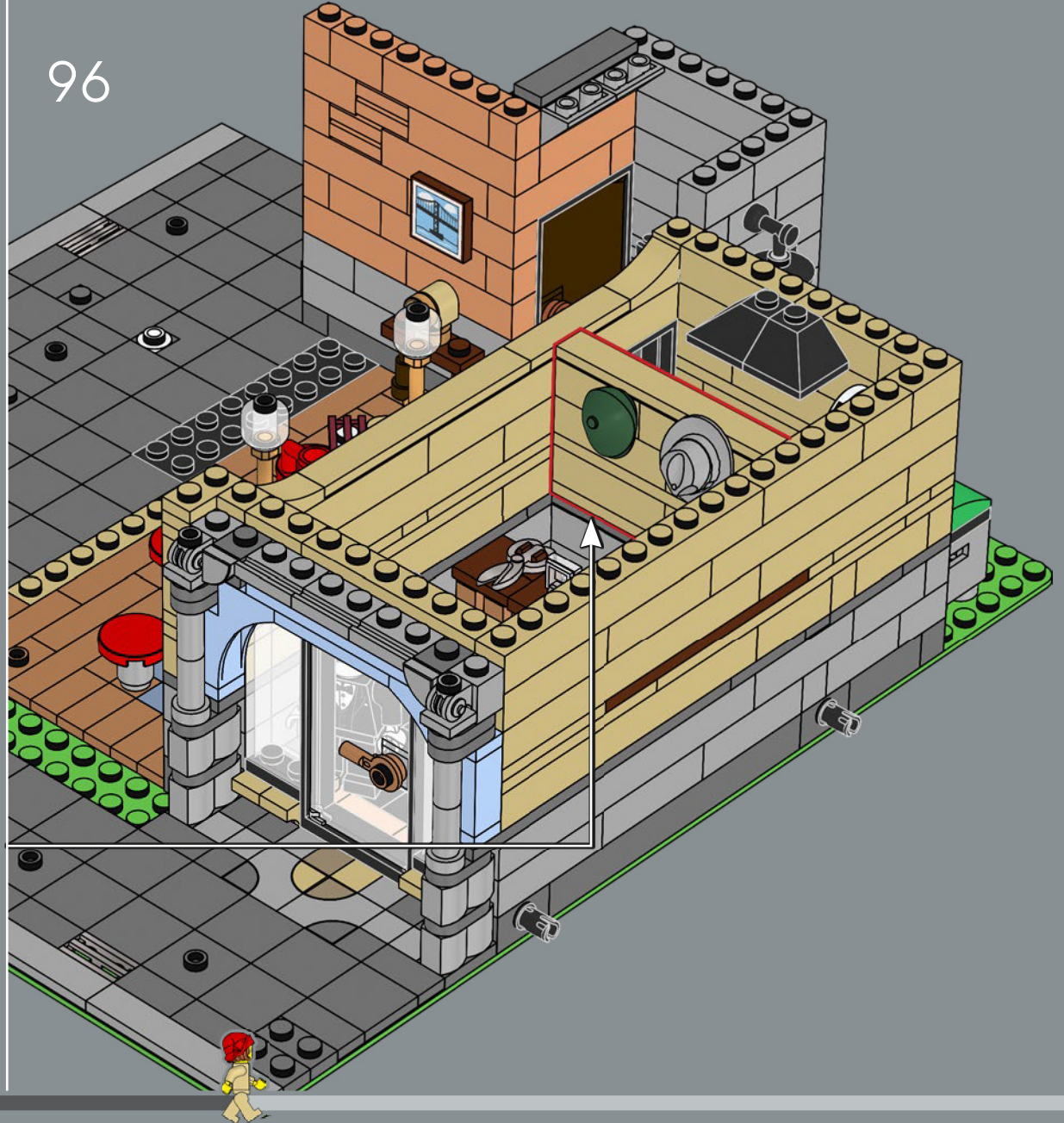



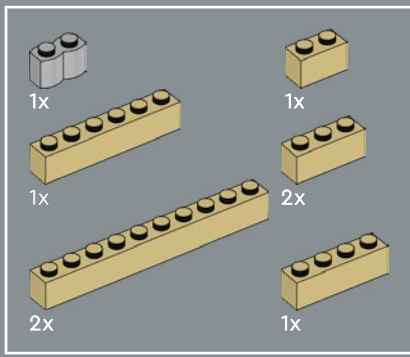

97

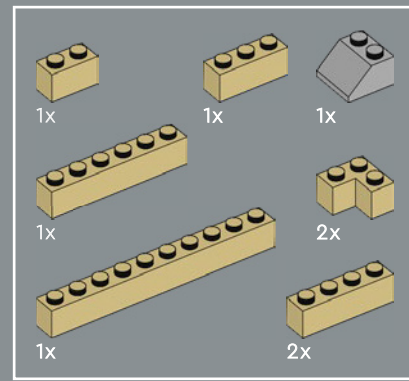
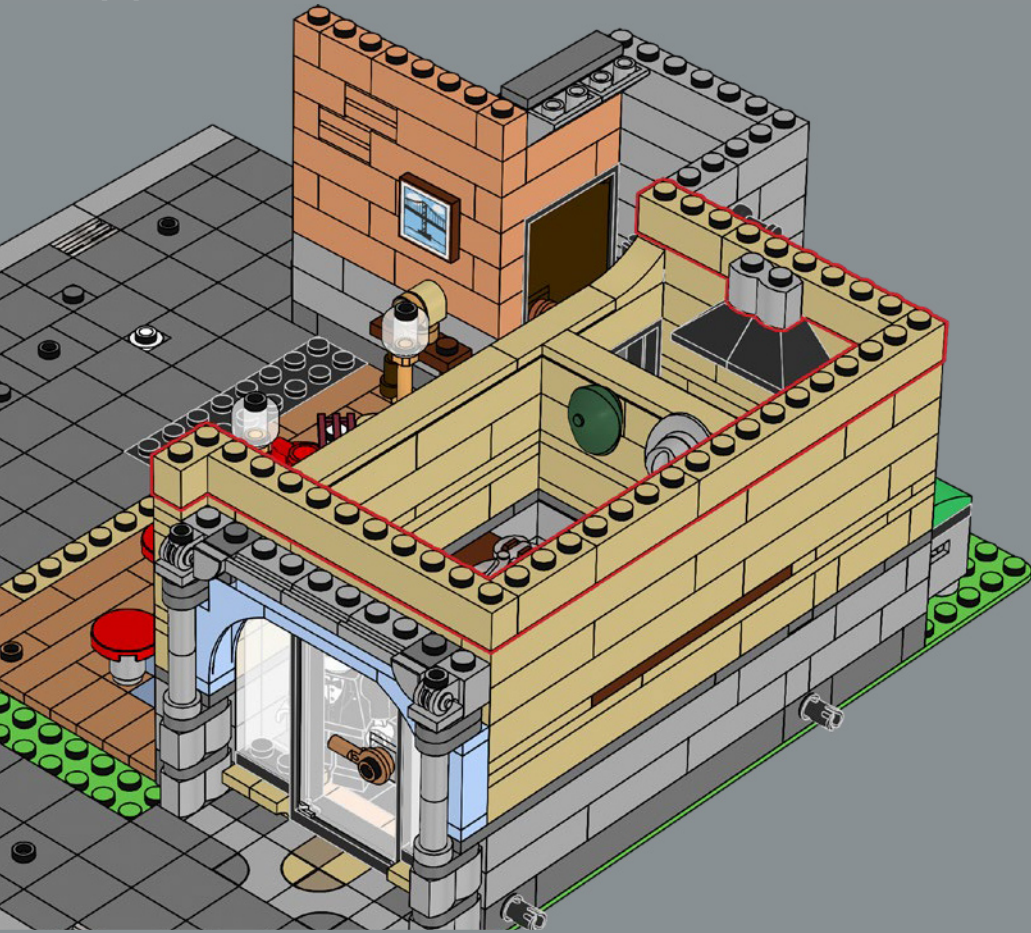

98





99

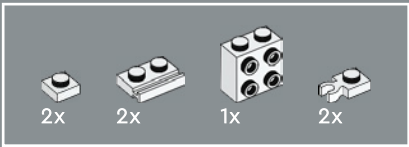

100

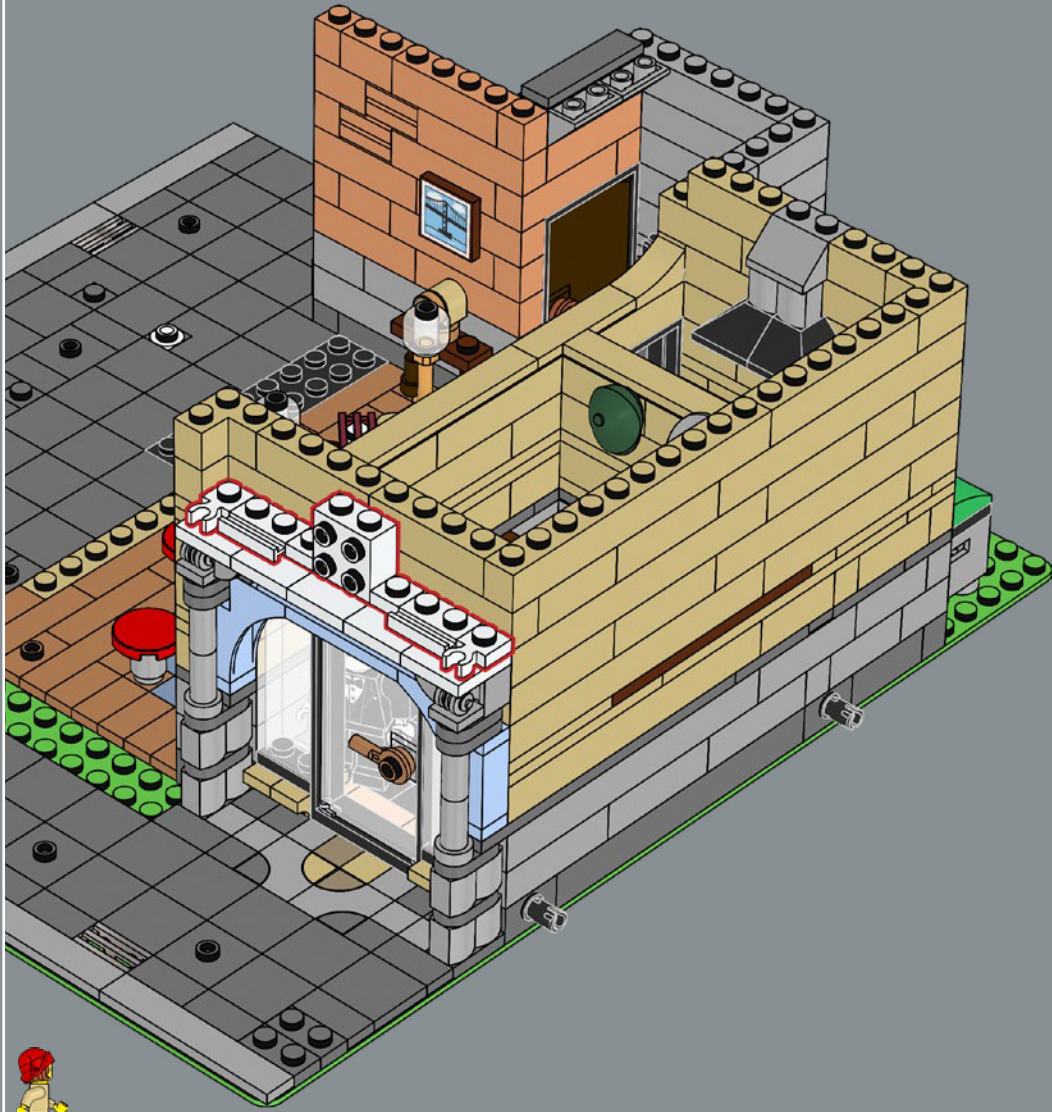

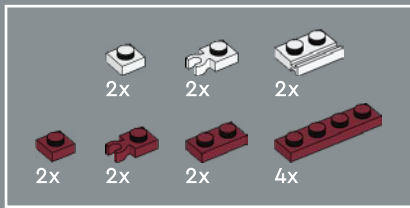

101

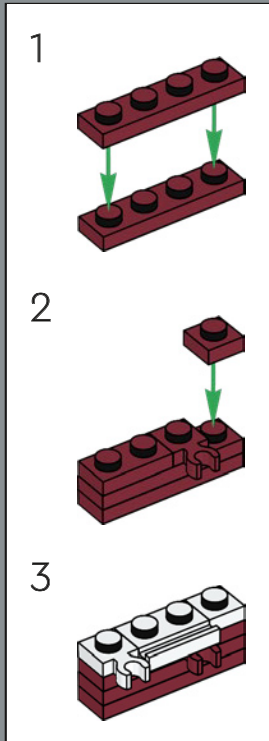
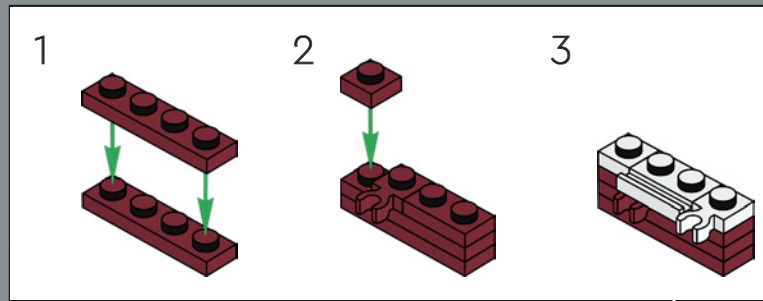



102



103



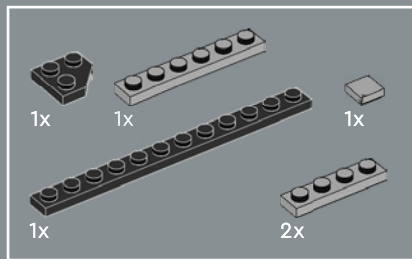

104

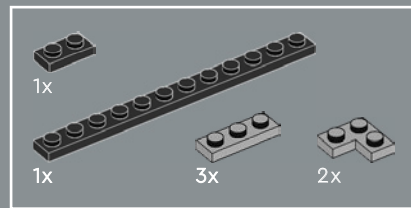

105



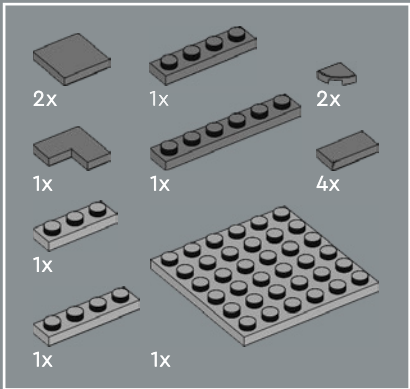

106

1

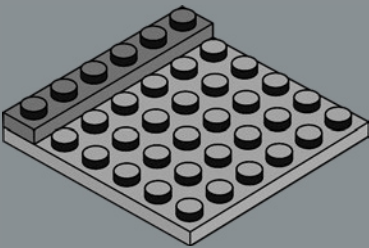

2

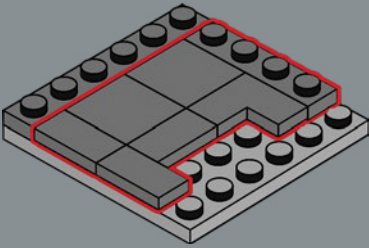

3

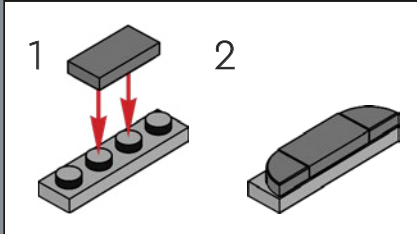
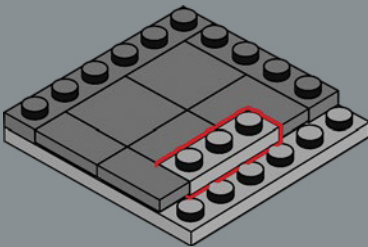

4

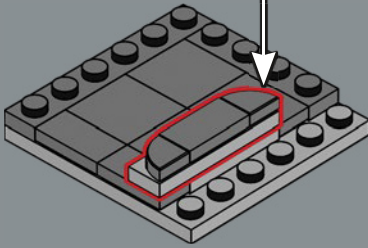

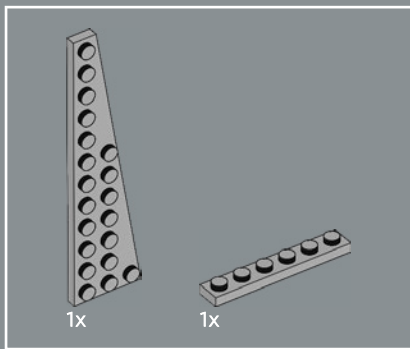

107

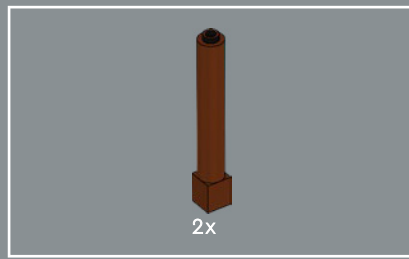

108



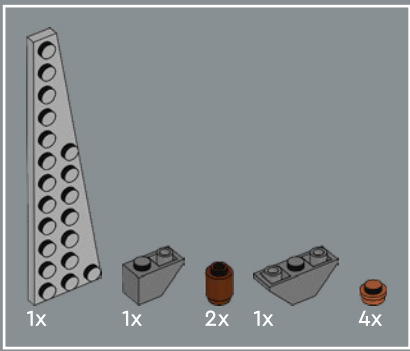

109

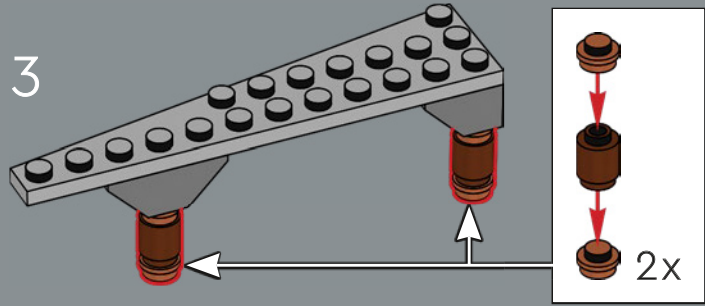
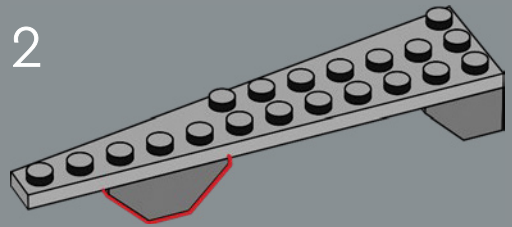
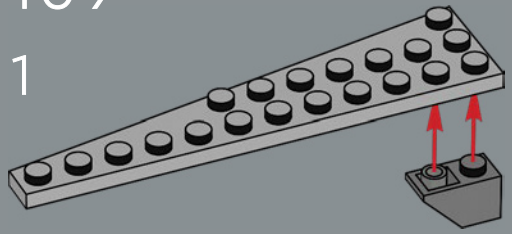



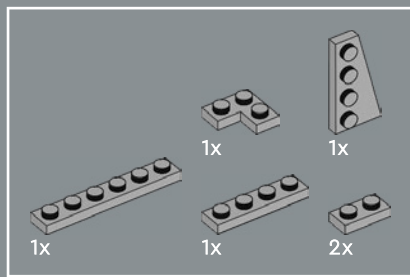

110



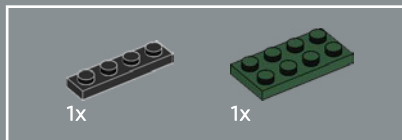
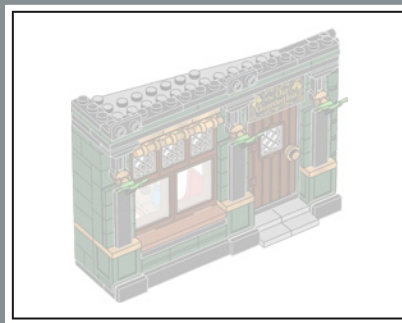
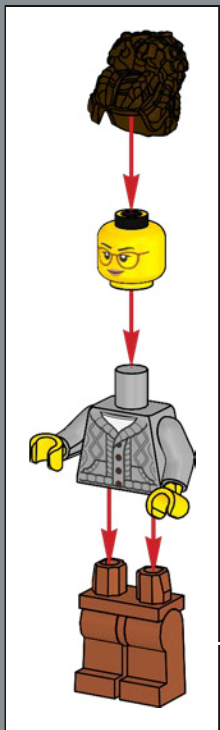

111

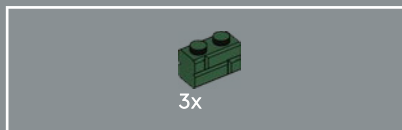
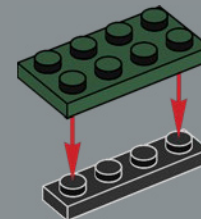

112

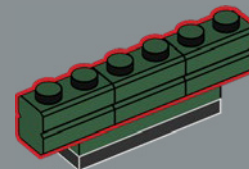



113

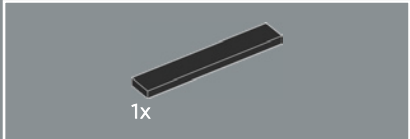
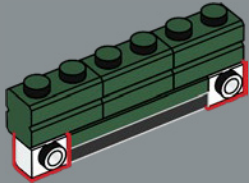

114

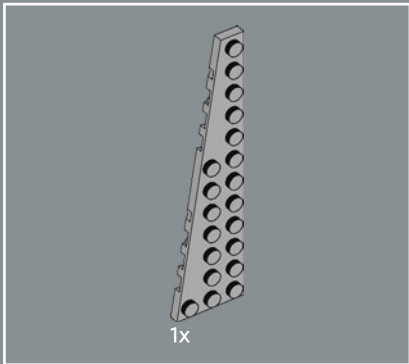
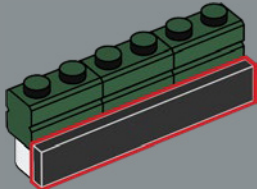

115

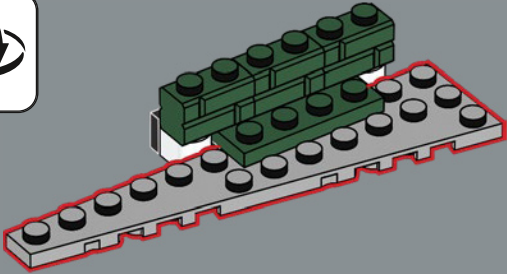

116

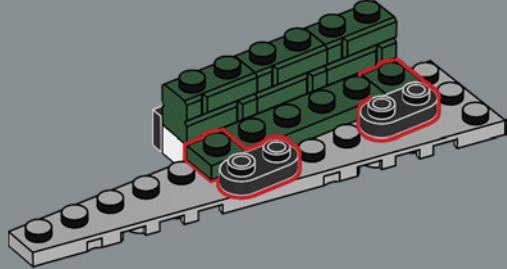



117

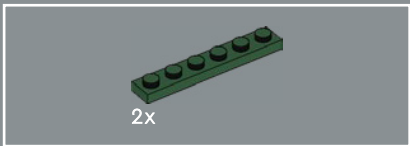
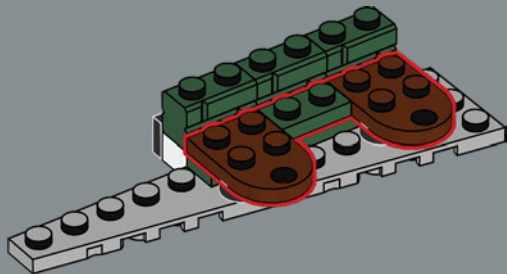

118

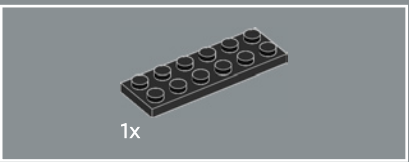
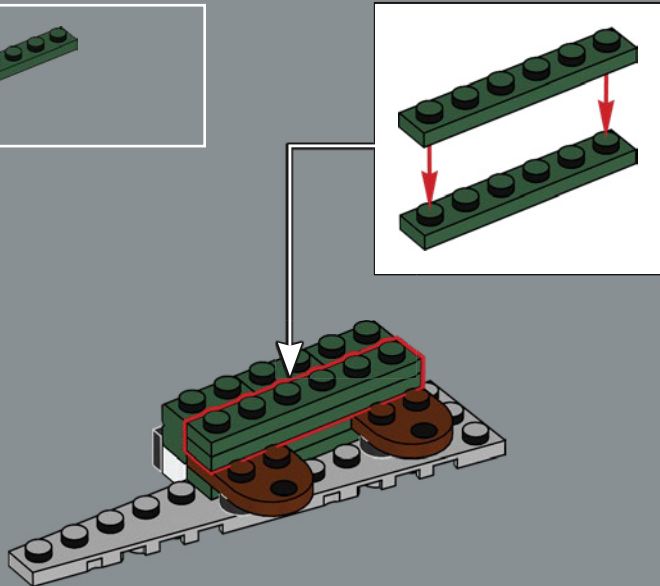

119

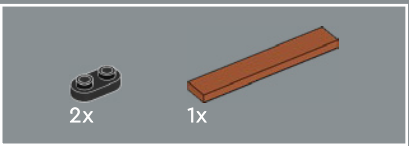
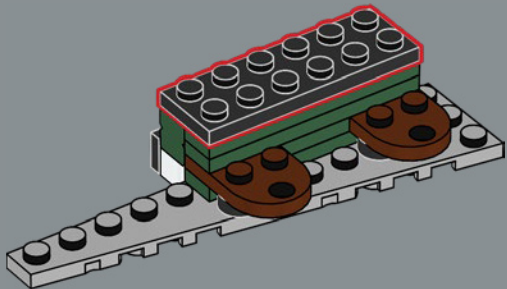

120

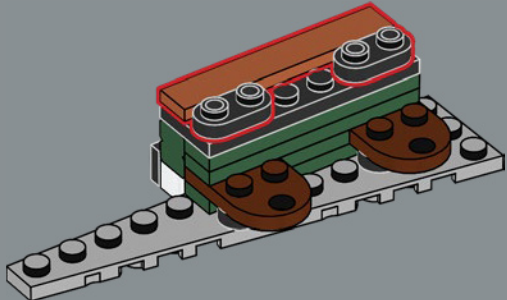

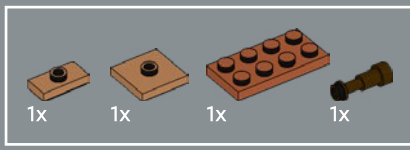

121

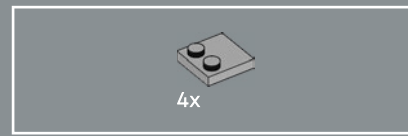
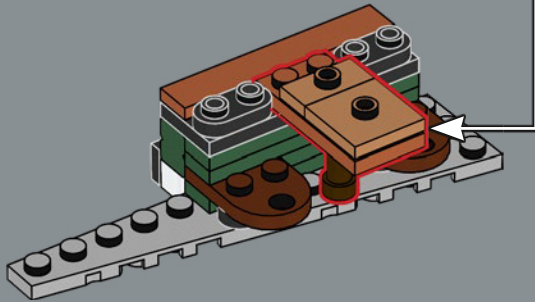
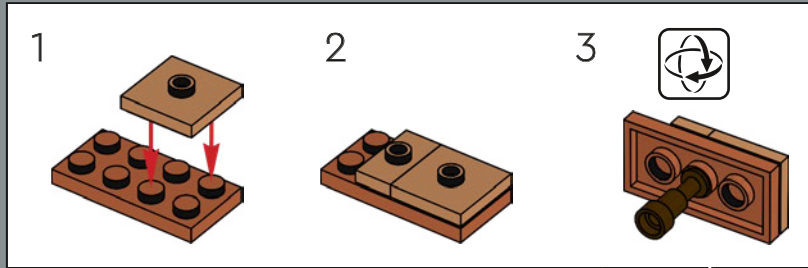

122

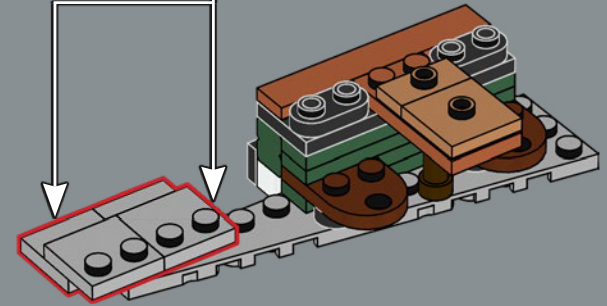
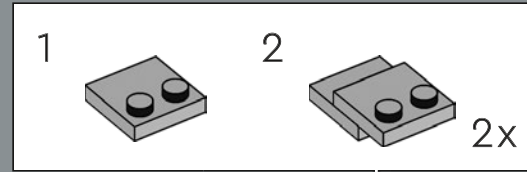

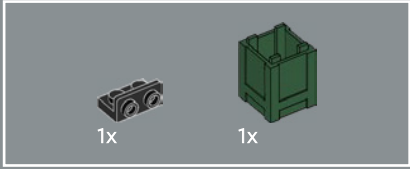
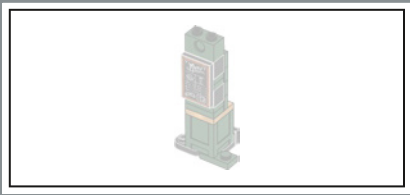

123

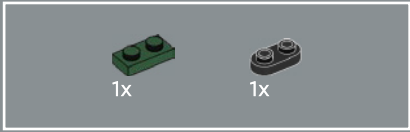
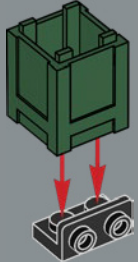

124

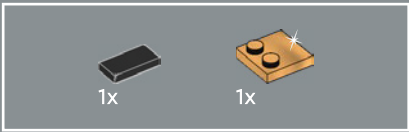
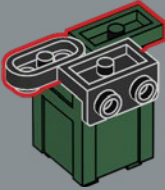

125

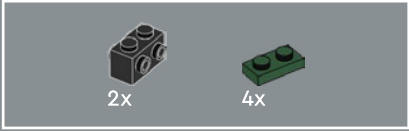
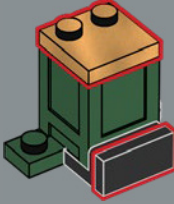

126

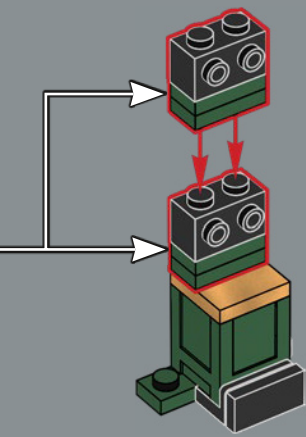
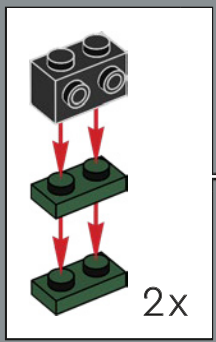



127

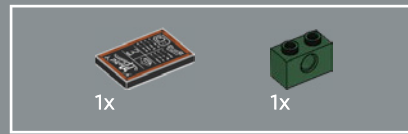
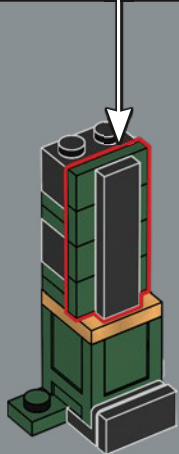
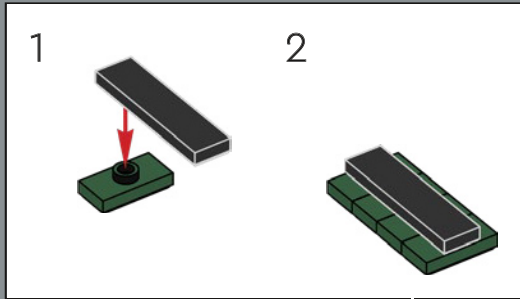

128



129

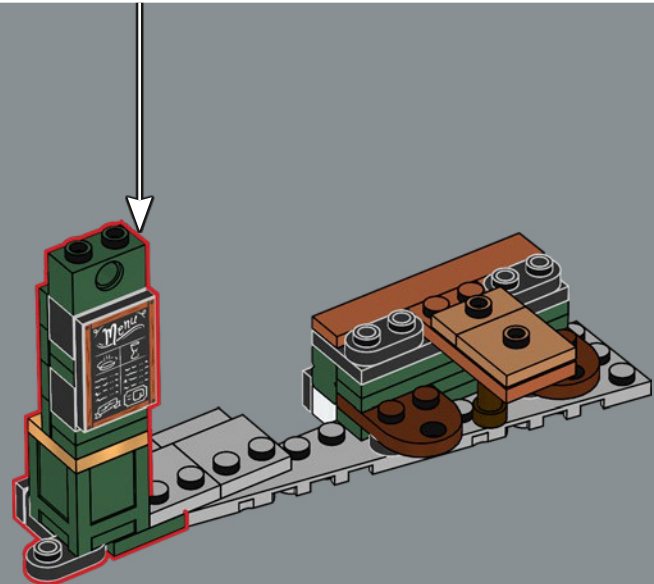

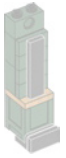

2x

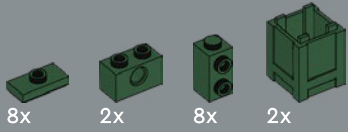
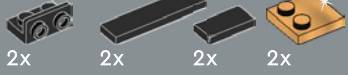

130

1

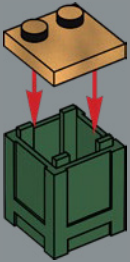

2



3

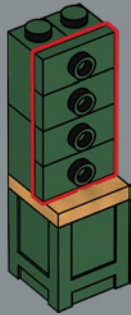

4

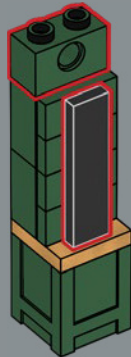

5

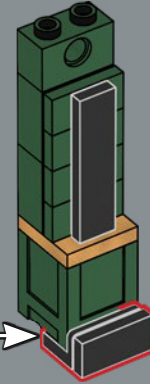
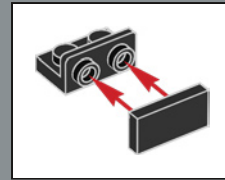

2x

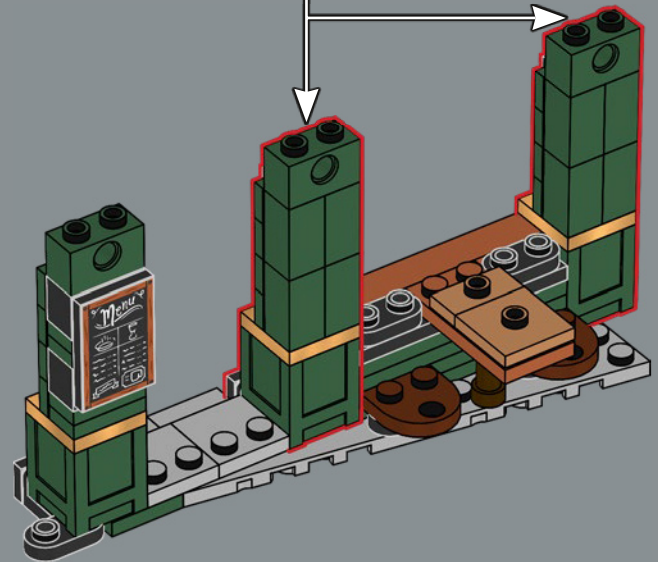



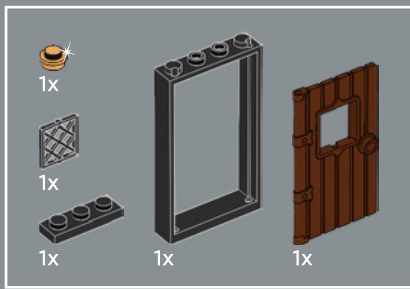

131

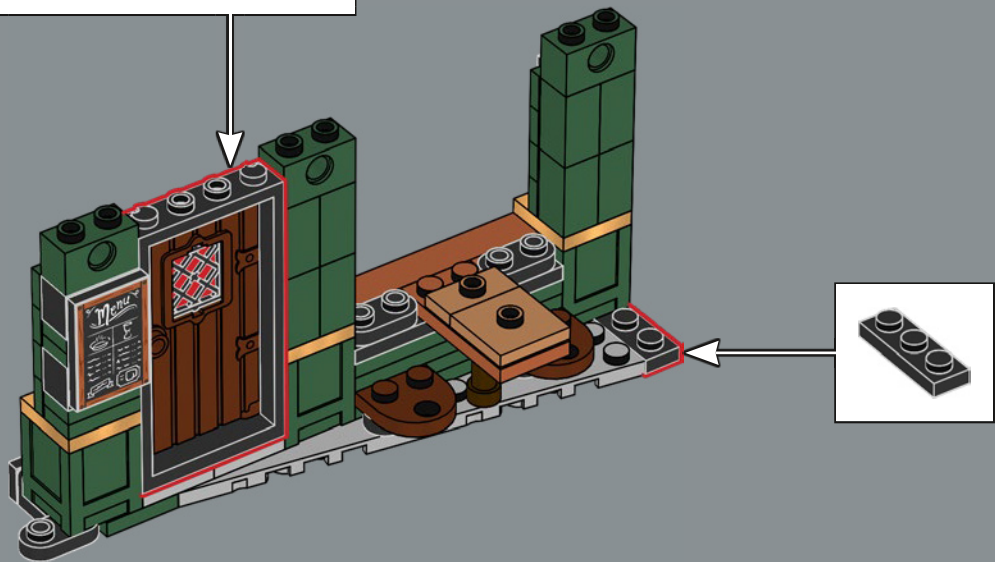
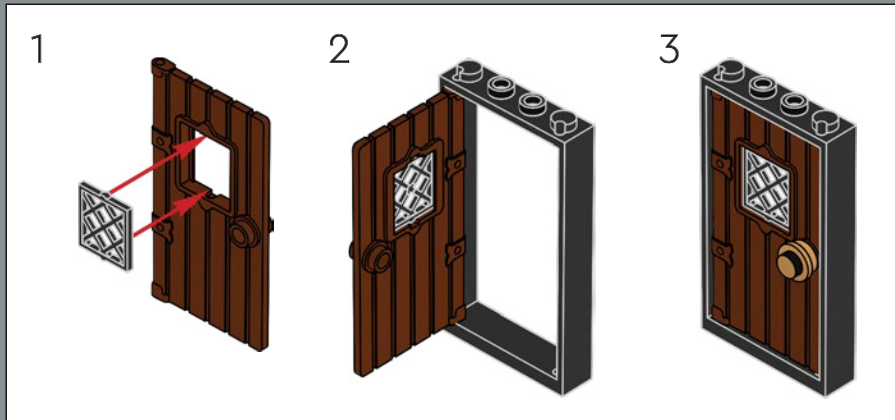

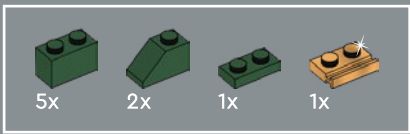

132

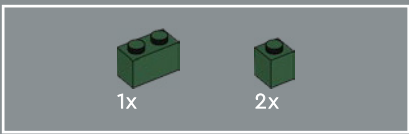
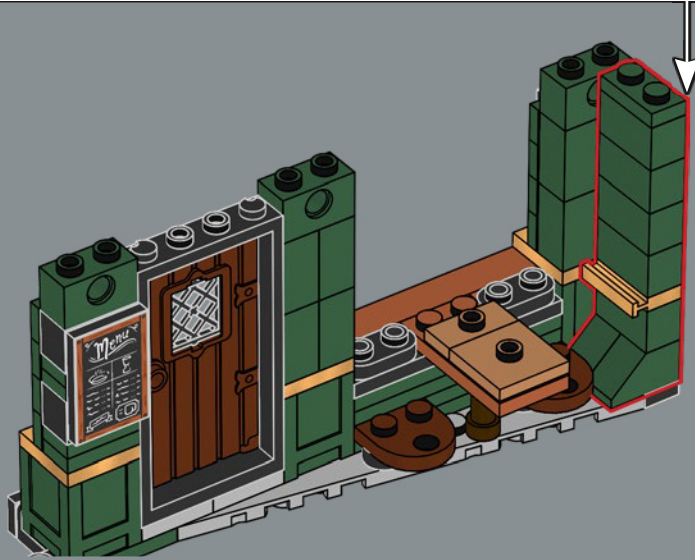
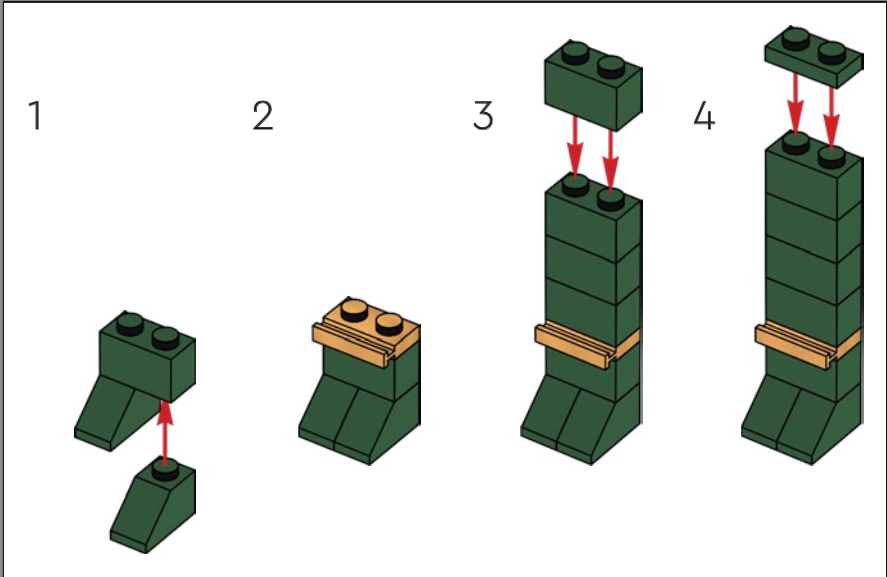

133

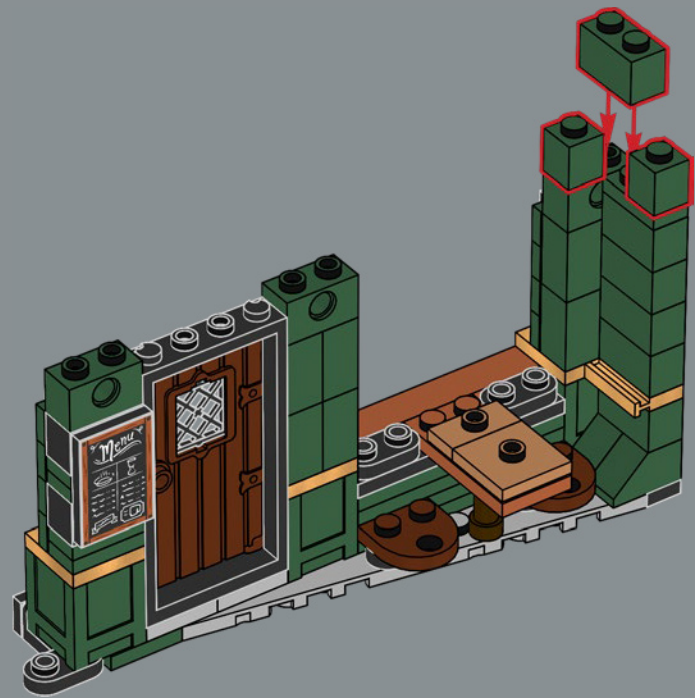

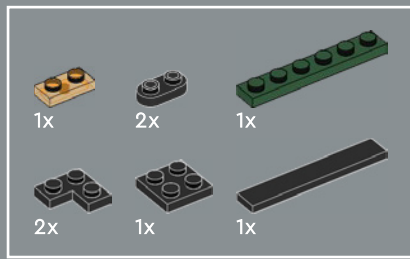

134

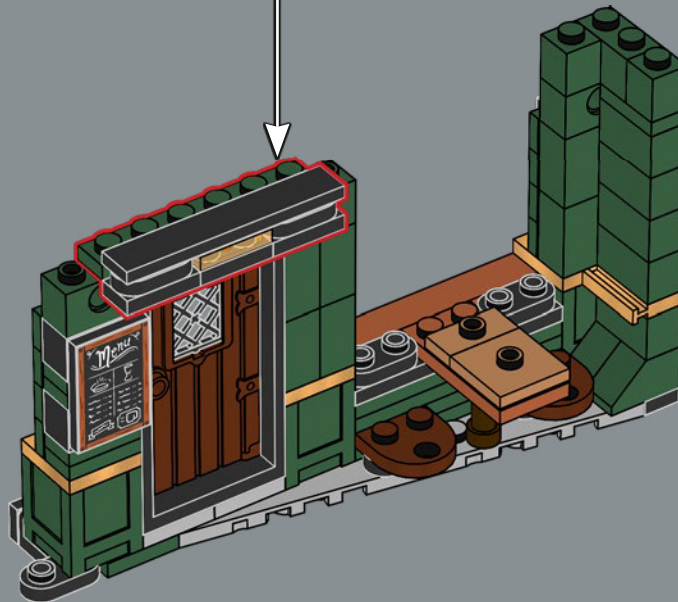
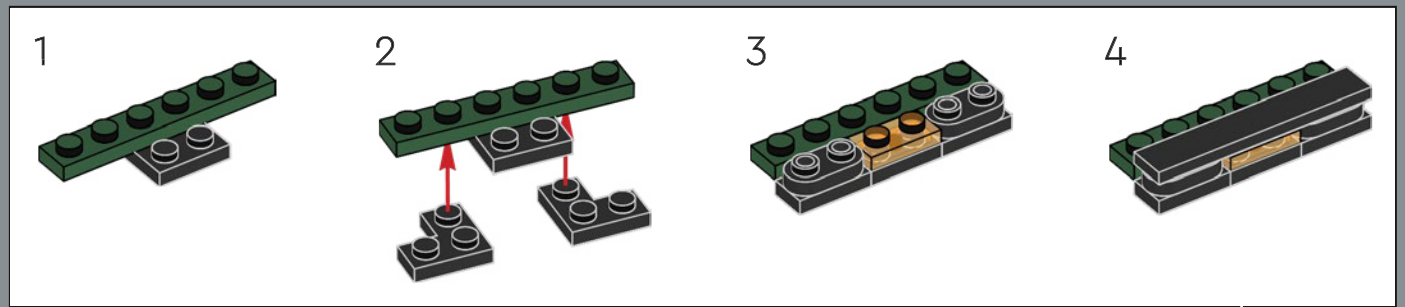



2x

135

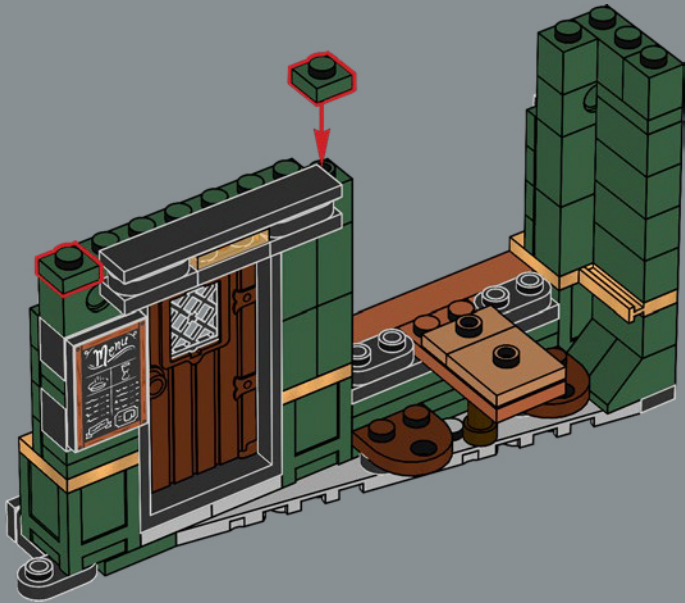

1x



2x



2x



2x

136

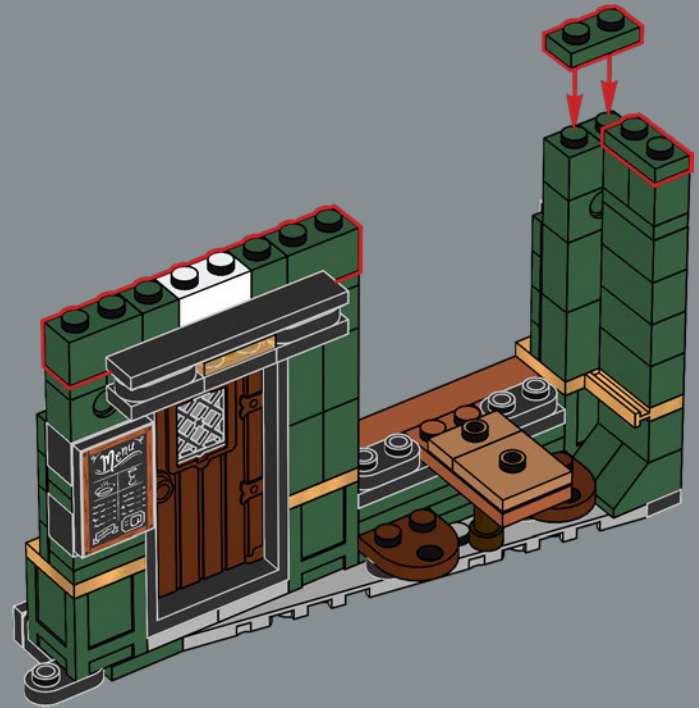

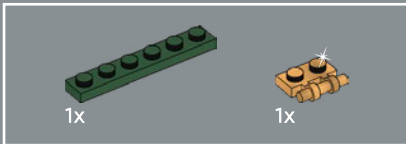

137

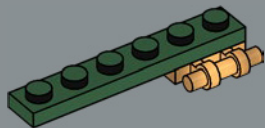

138

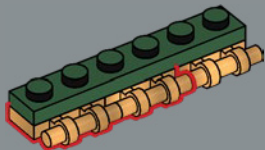

139

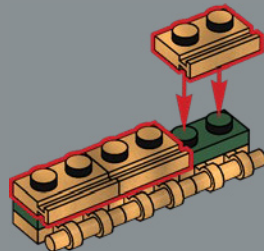

140

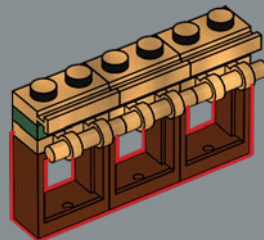

141

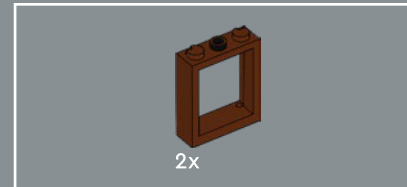
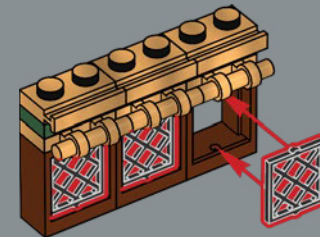

142

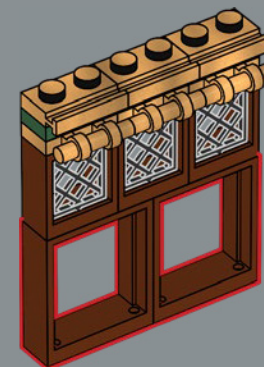



2x

143

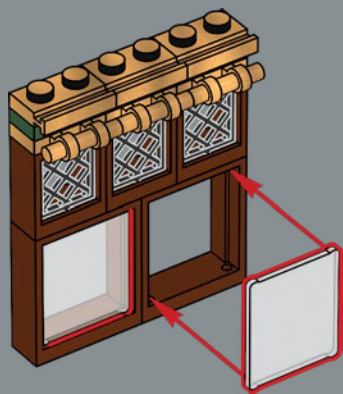

144

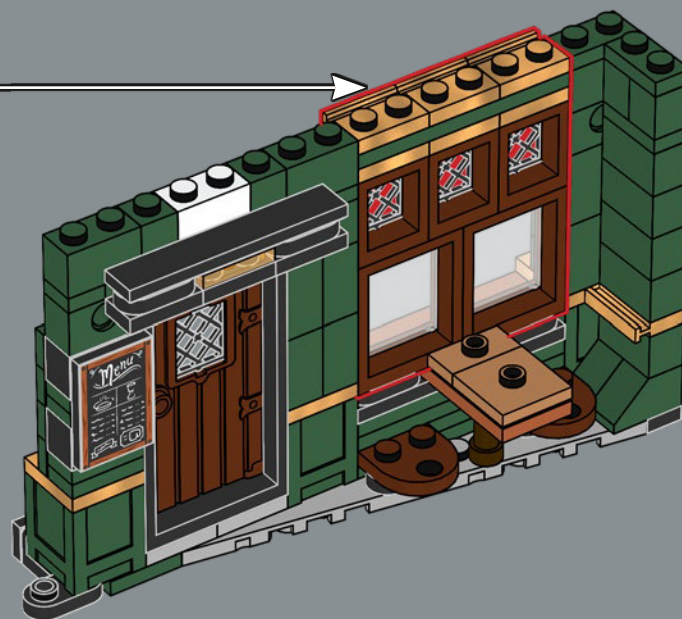

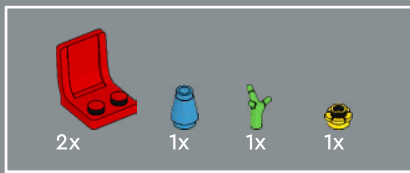

145

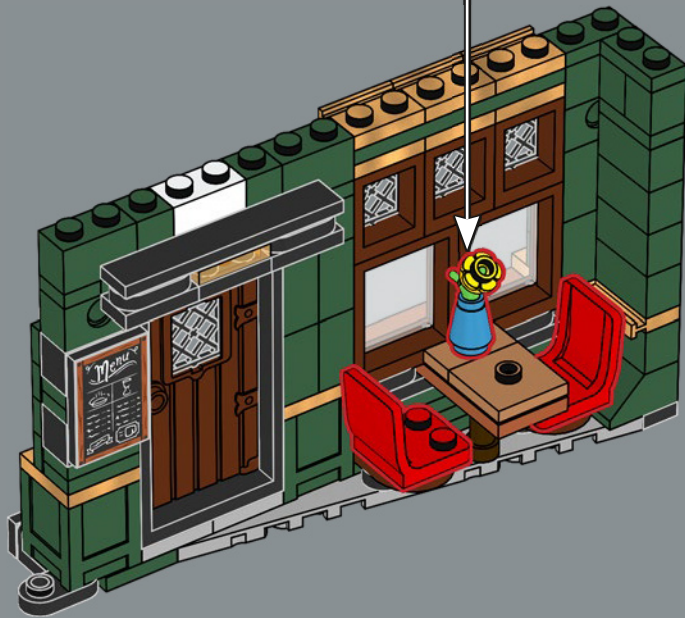
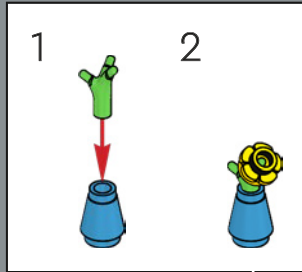

146

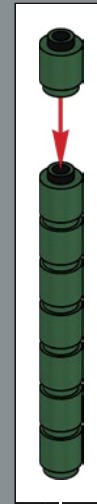

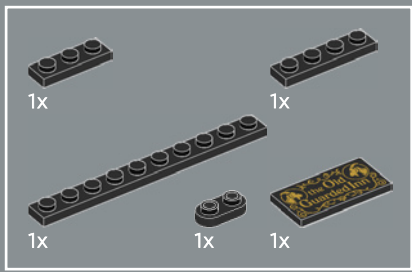

147

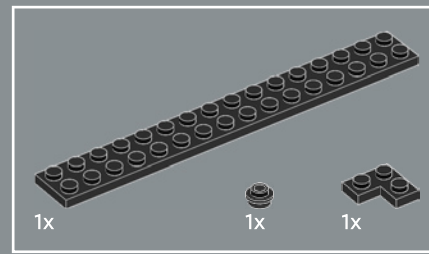

148





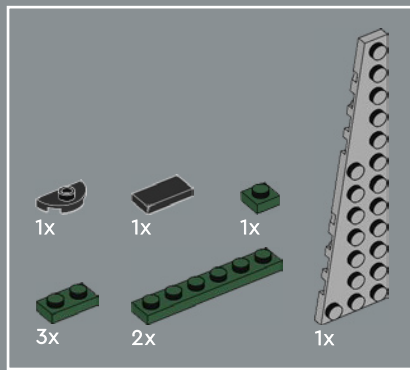

149

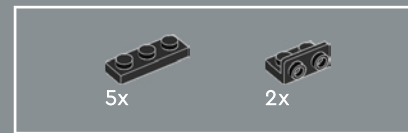

150





151

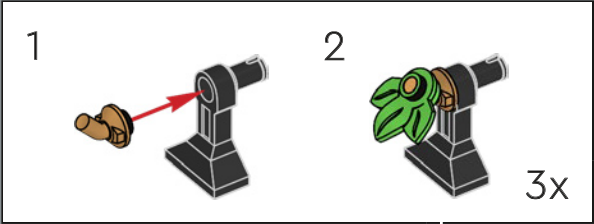

What a peculiar angle! Is it a leftover from a time when the route of the street was not yet clearly defined? Or maybe the restaurant owner just wanted to add an extension after seeing the LEGO® Icons Boutique Hotel (10297) on the other street corner!

152

Quel angle particulier ! Est-ce un vestige de l'époque où le tracé de la rue n'était pas encore clairement défini ? Ou peut-être que la propriétaire du restaurant a simplement voulu ajouter une extension après avoir vu l'hôtel-boutique LEGO® Icons (10297) à l'autre coin de rue !

¿Qué ángulo tan peculiar! ¿Es un vestigio de una época en la que el trazado de la calle aún no estaba claramente definido? ¿Tal vez el dueño del restaurante decidió añadir una ampliación después de ver el Hotel Boutique LEGO® Icons (10297) en la otra esquina?



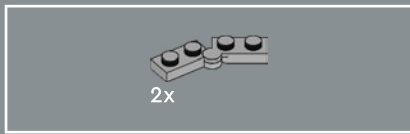

153

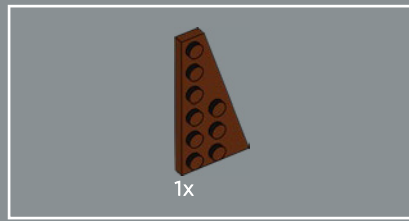

154

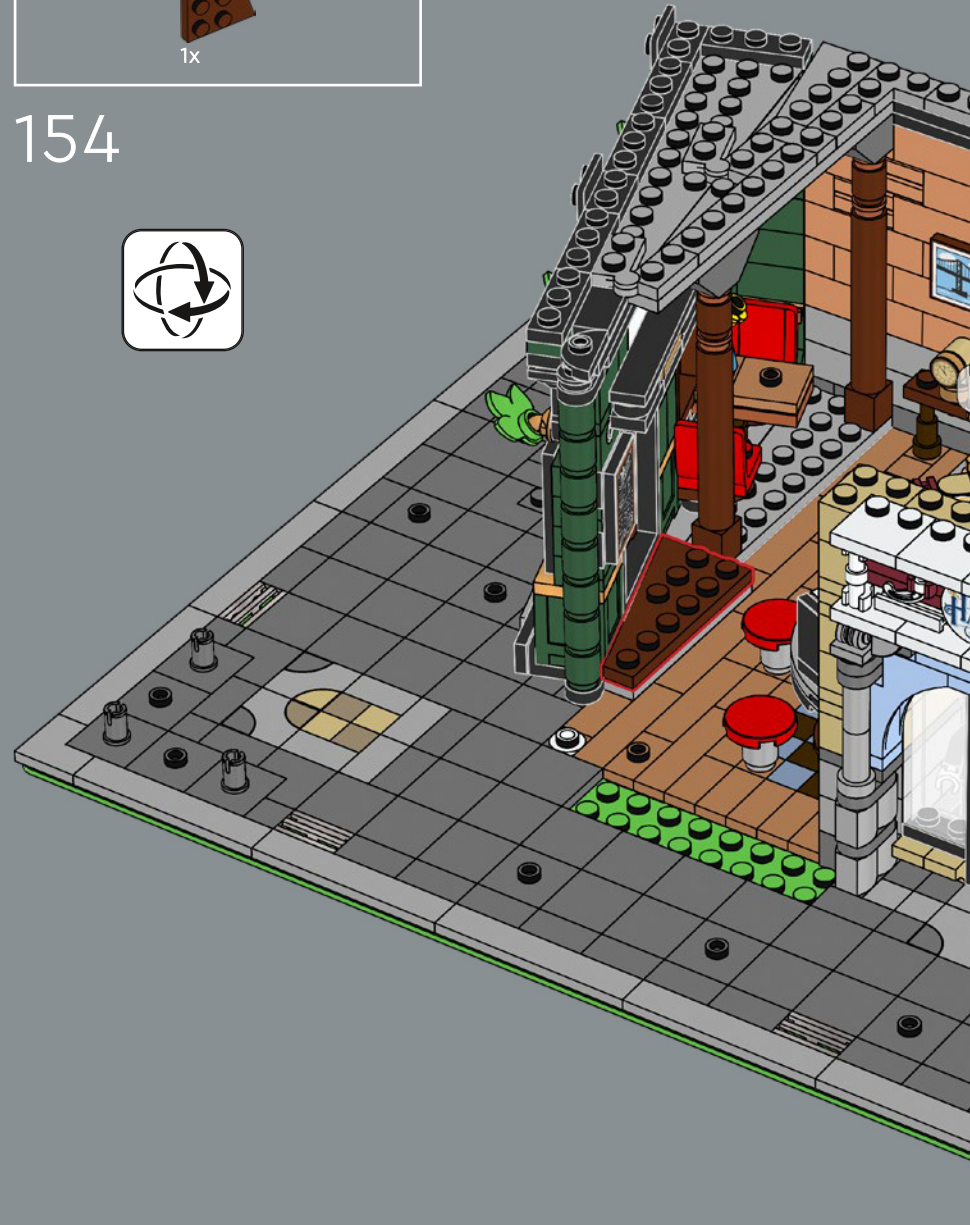

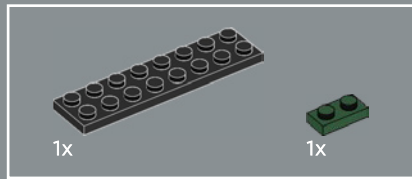
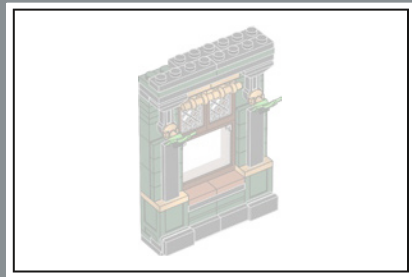

155

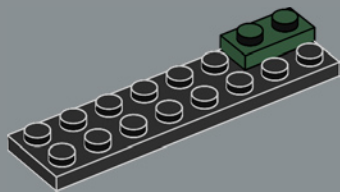

156

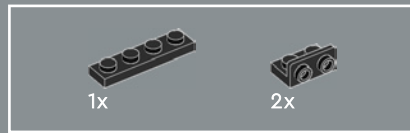
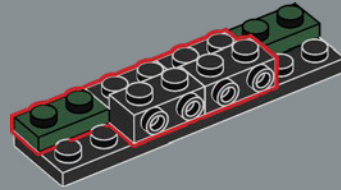

157

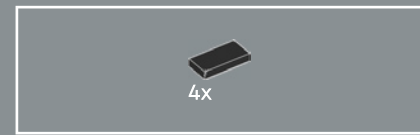
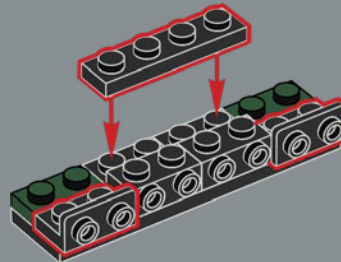

158

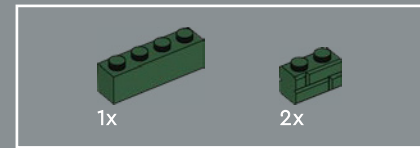
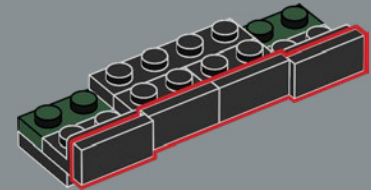

159

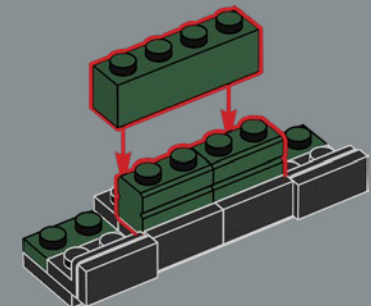

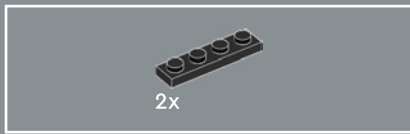

160

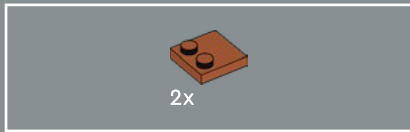
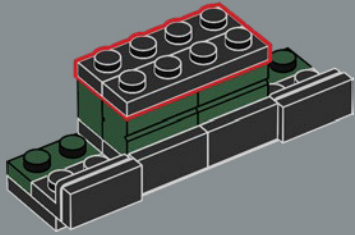

161

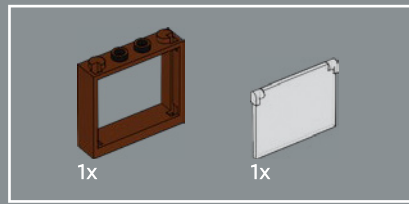
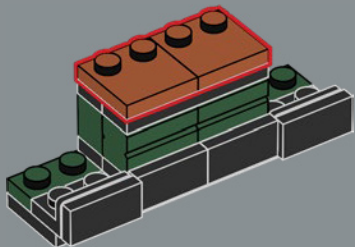

162

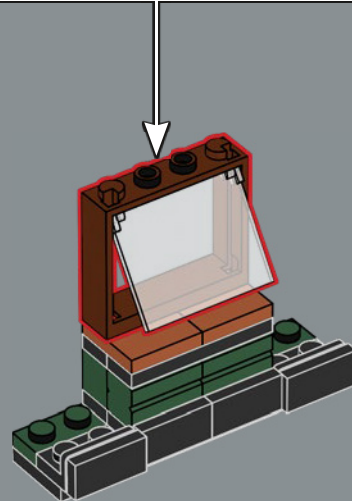
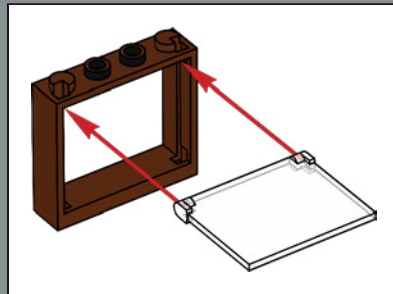

163

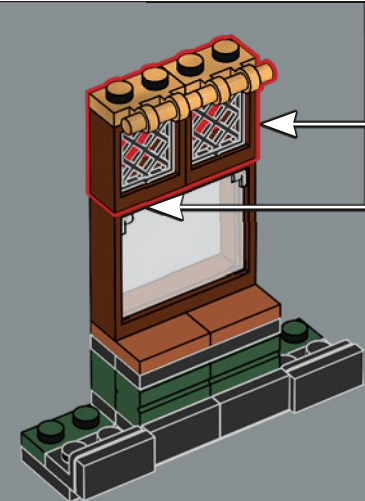
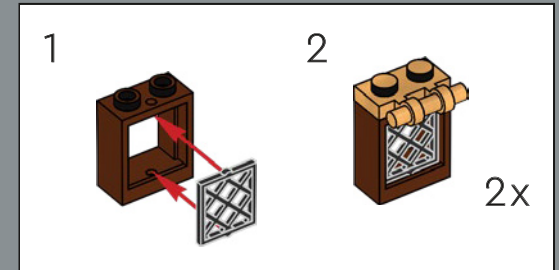

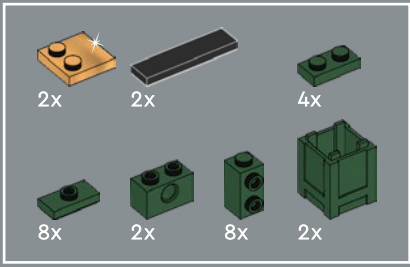

164

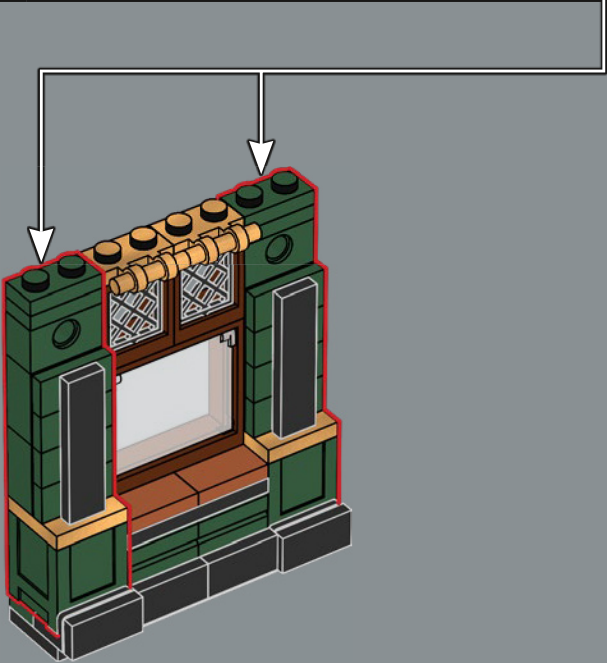
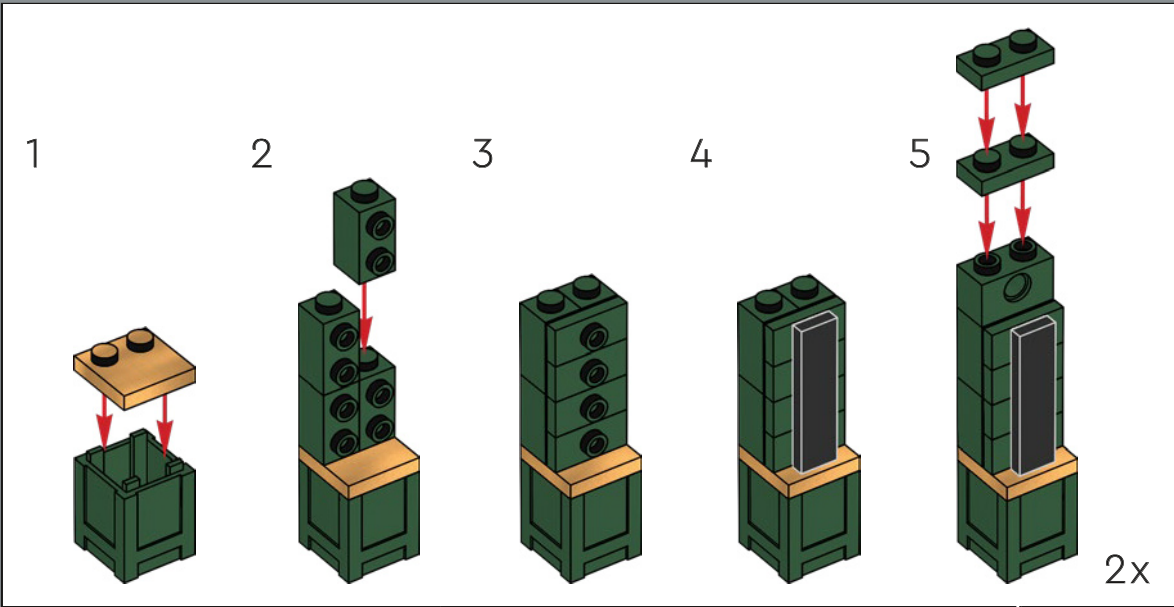

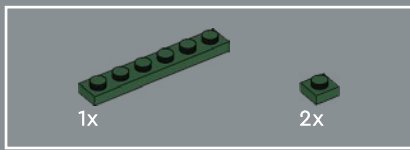

165

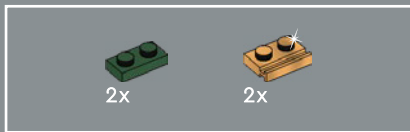
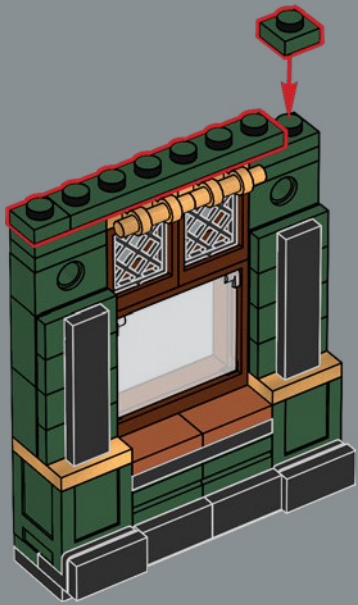

166

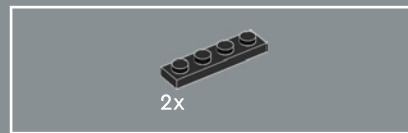
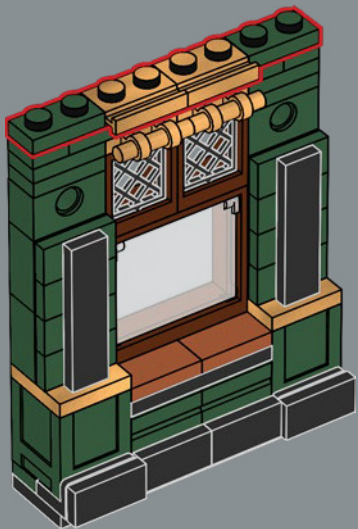

167

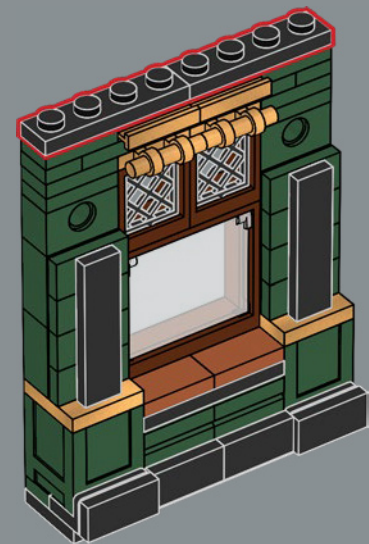

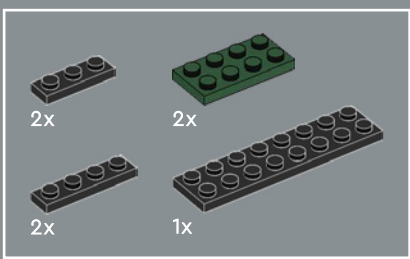

168

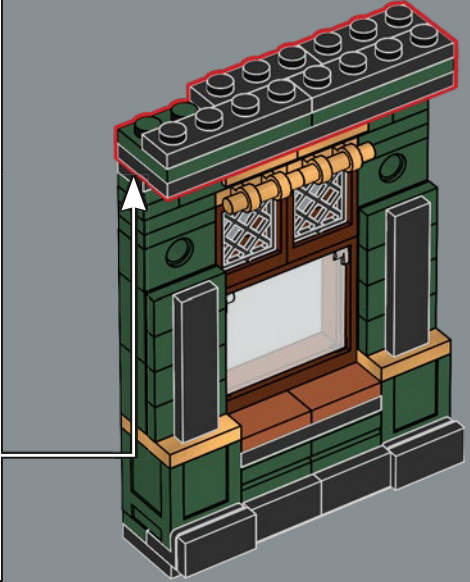
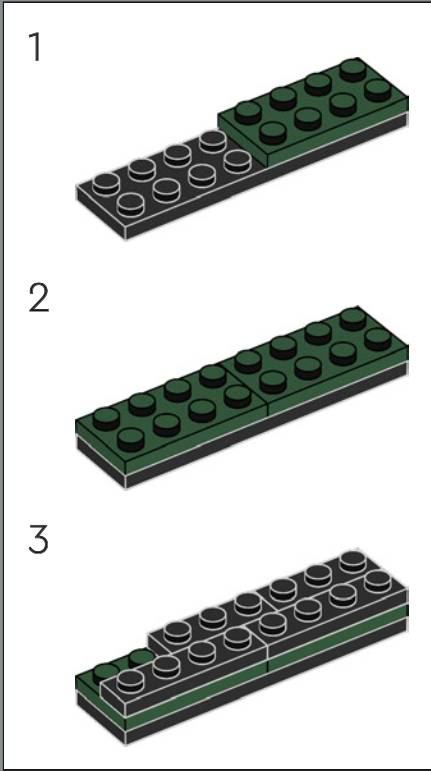

169

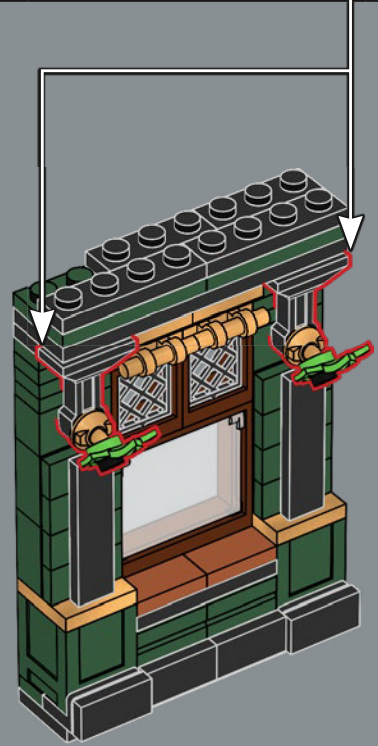
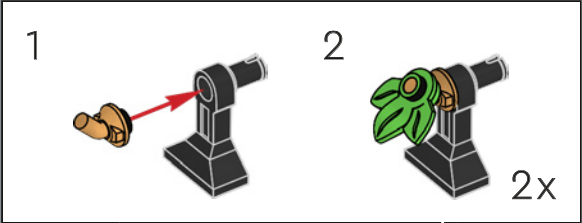



170



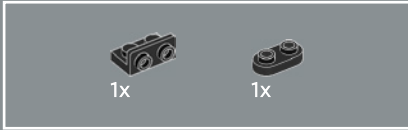
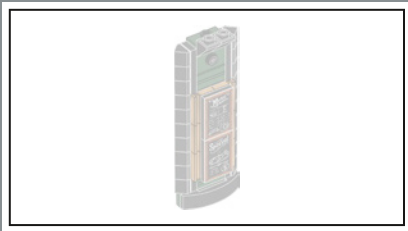

171

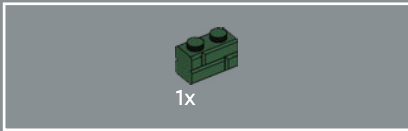
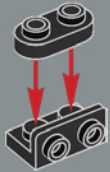

172

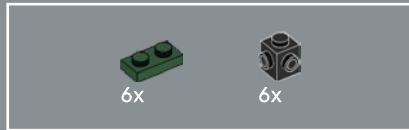
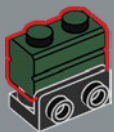

173

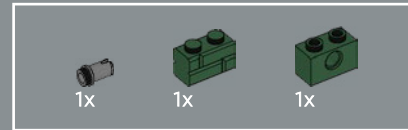
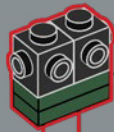
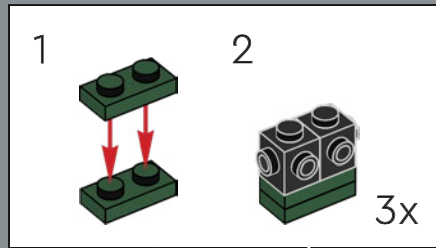

174

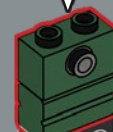
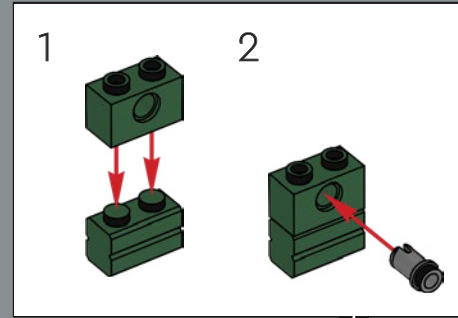



175

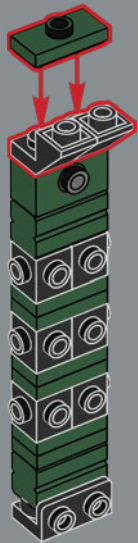

176

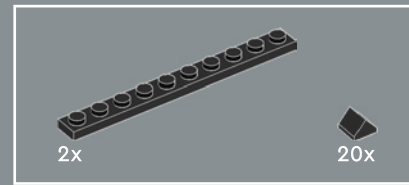
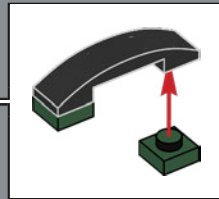
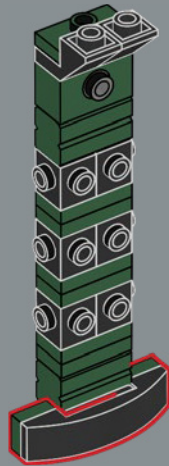

177

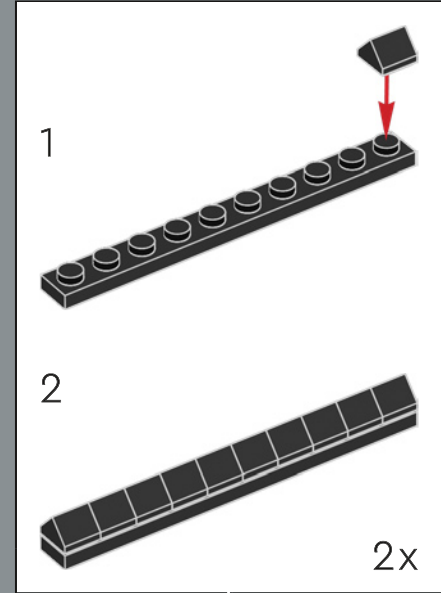
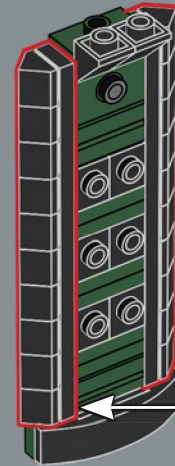



6x

178

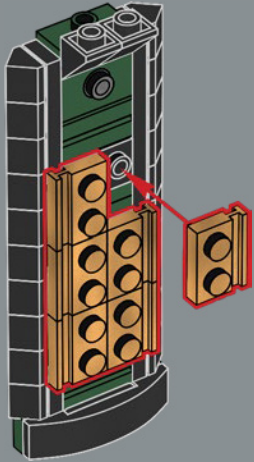

1x



1x

179



180



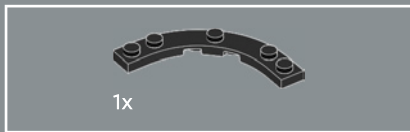

181



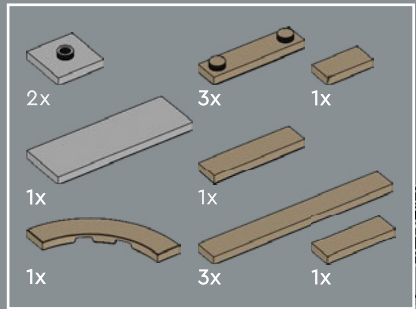

182





What might the Old Guarded Inn have looked like back in the day? The curator of the LEGO® Icons Natural History Museum (10326) must surely have more information in his archives.

À quoi aurait pu ressembler la vieille auberge à l'époque ? Le conservateur du musée d'histoire naturelle LEGO® Icons (10326) doit sûrement avoir plus d'informations dans ses archives.

¿Cómo habrá sido el Old Guarded Inn en sus buenos tiempos? Seguramente, el curador del Museo de Historia Natural LEGO® Icons (10326) tiene más información en sus archivos.

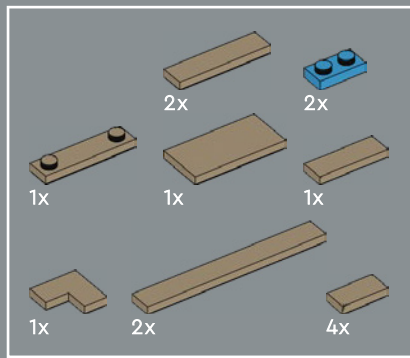

183



1x  1x 

184



2x 

185





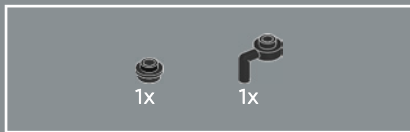

186



187



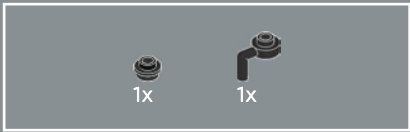

188

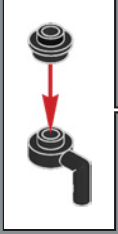

189





190

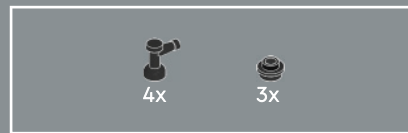
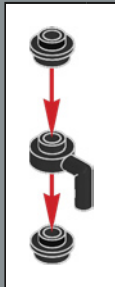
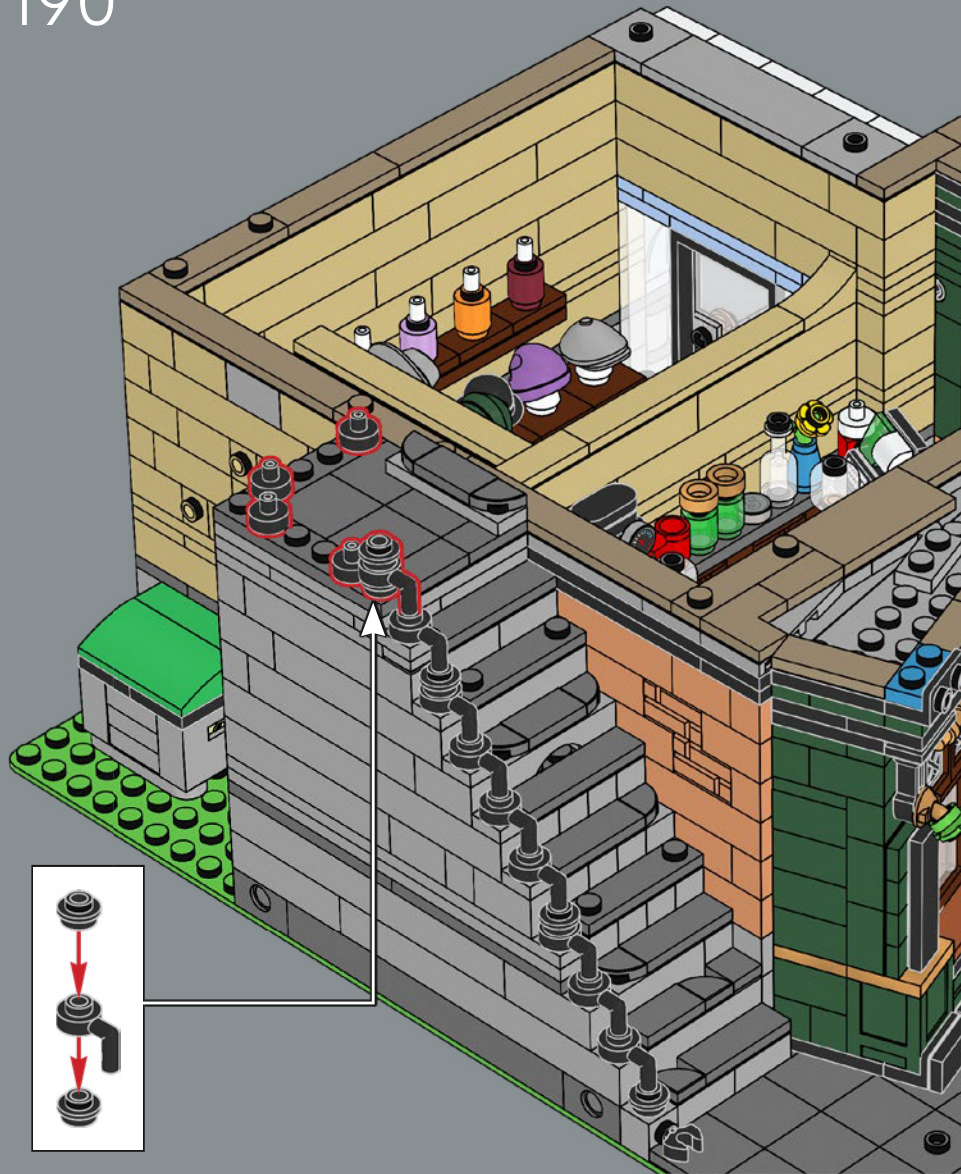

191



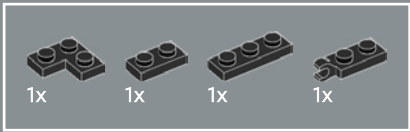

192

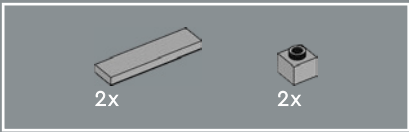

193



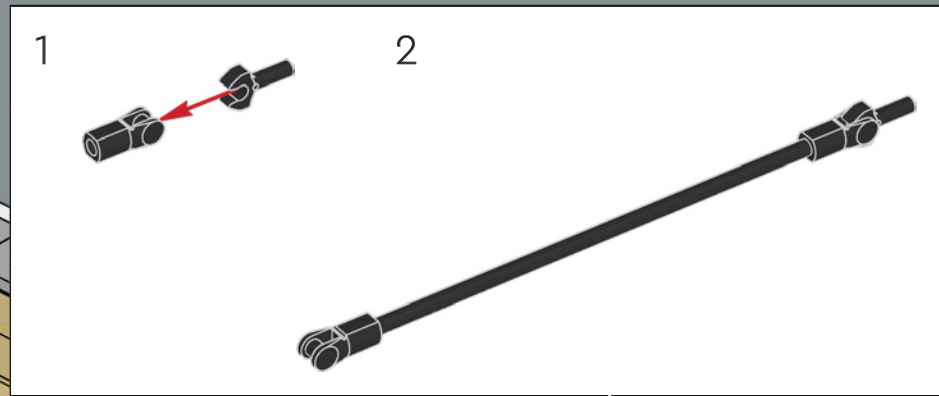
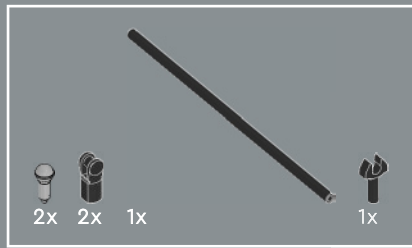

194

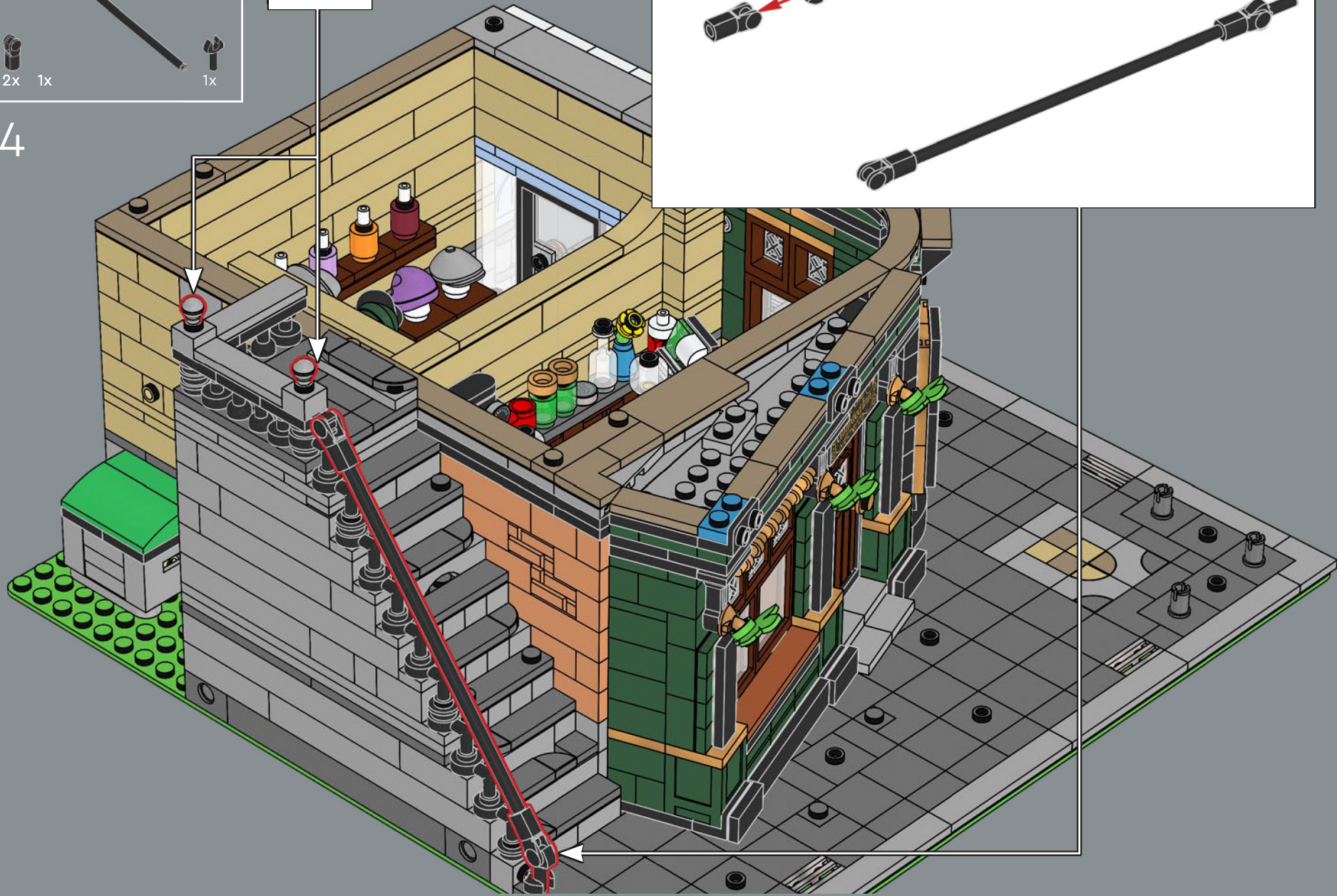

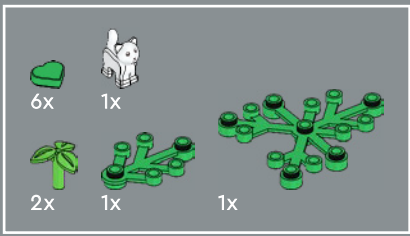

195

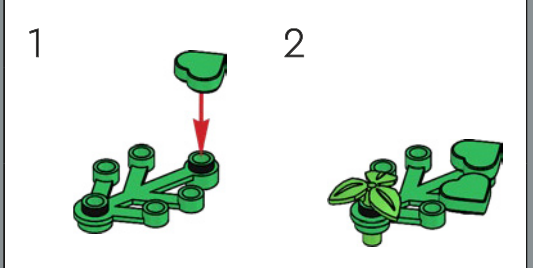
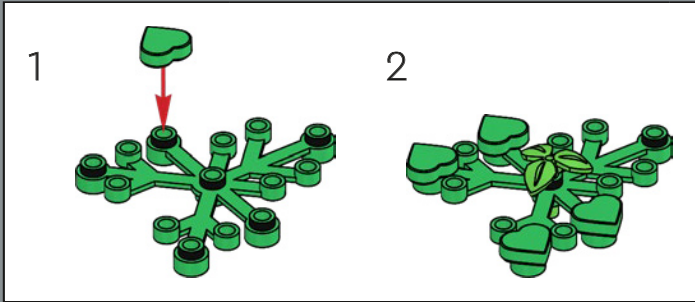



196

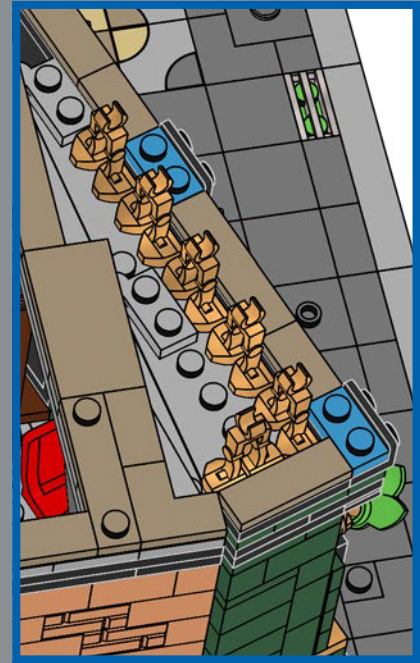

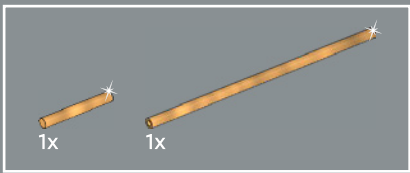

197







198





199

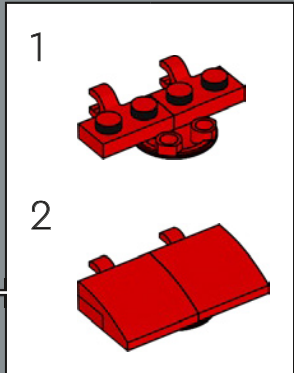
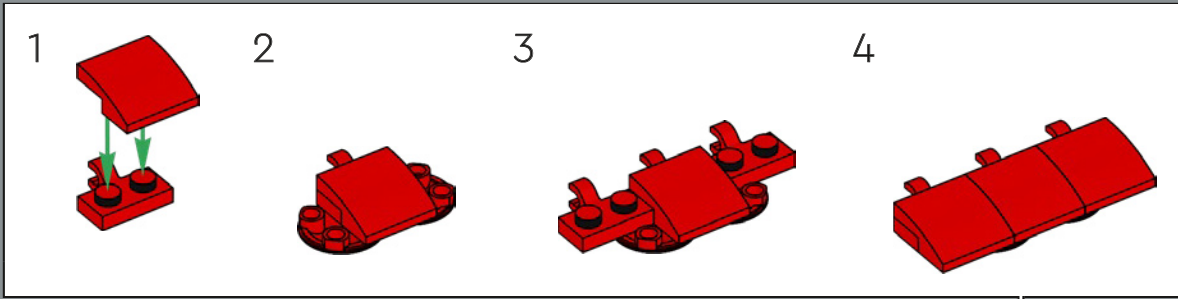



200

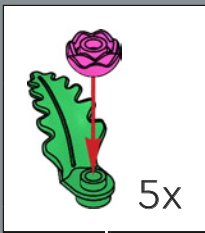



8x



4x



4x

201

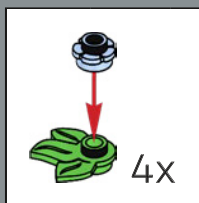
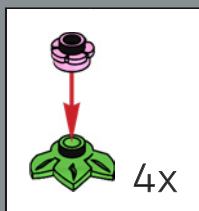

All these flowers come from the florist in LEGO® Creator Expert Assembly Square (10255). She always manages to find new floral arrangements!

Toutes ces fleurs proviennent de la fleuriste de la place de l'assemblée LEGO® Creator Expert (10255). Elle parvient toujours à trouver de nouvelles compositions florales !

Todas estas flores vienen de la florería de la Gran Plaza LEGO® Creator Expert (10255). ¡Siempre hay nuevos y creativos arreglos florales!

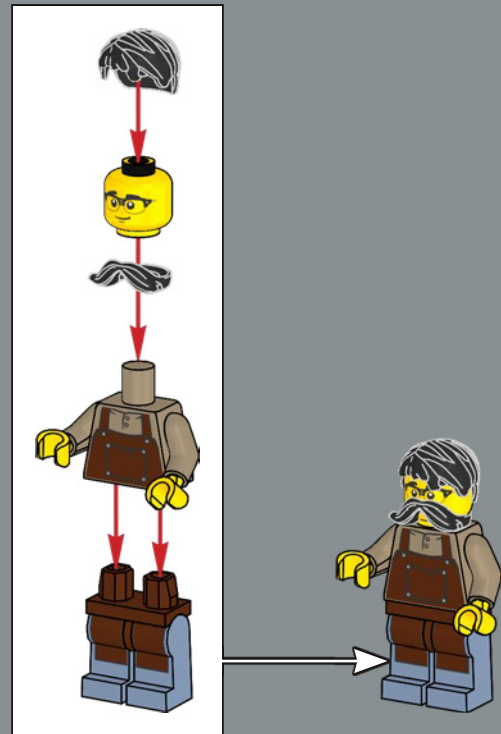
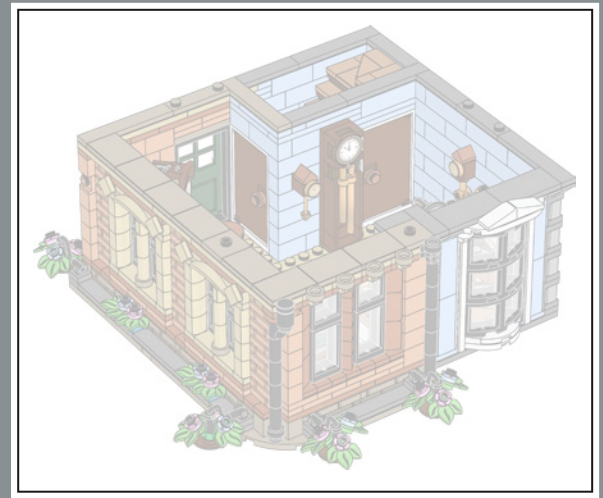
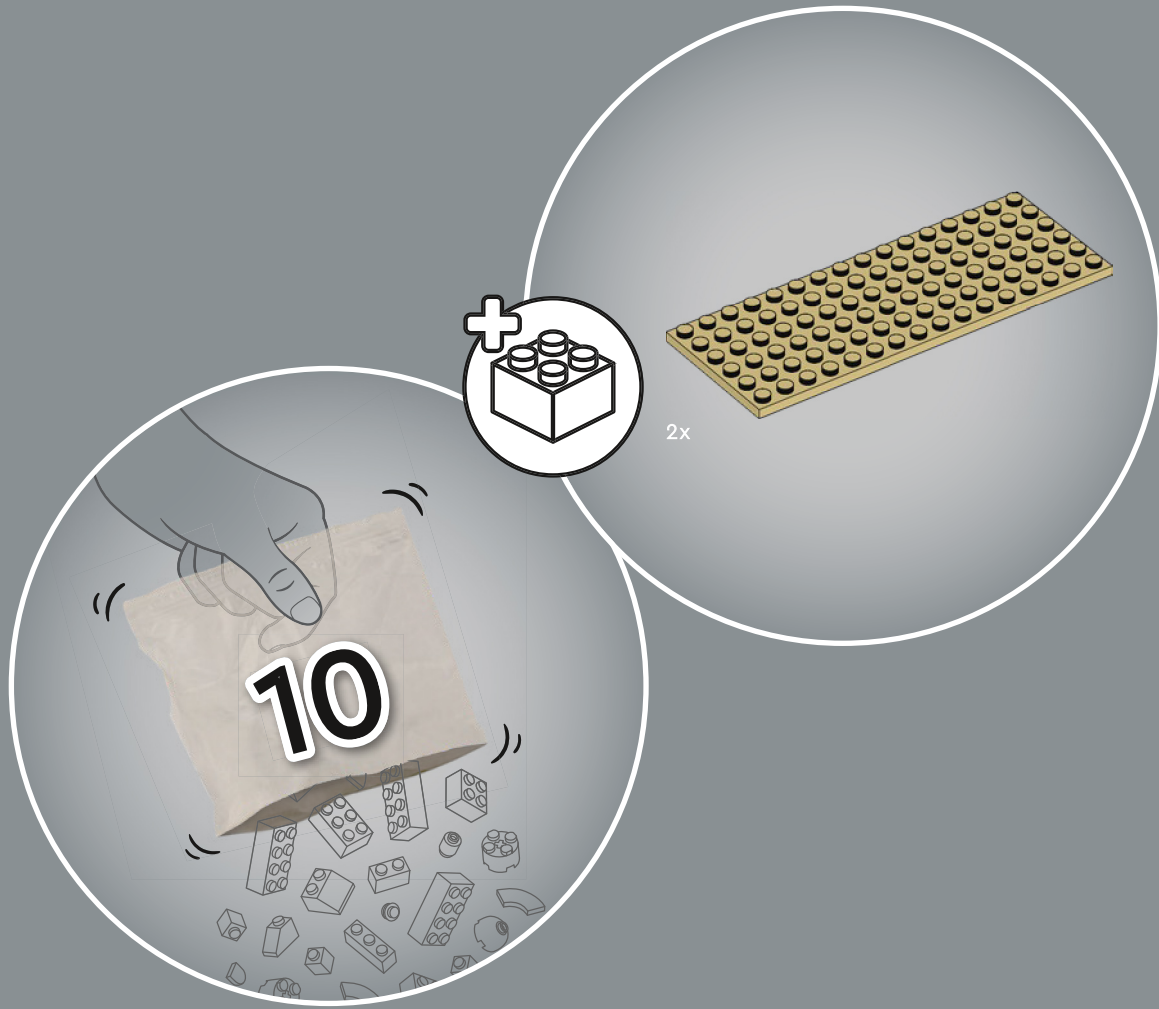

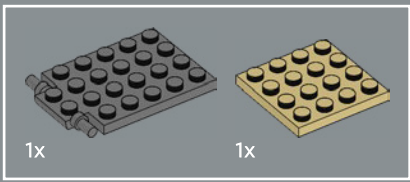

202

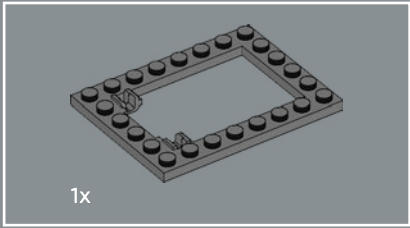
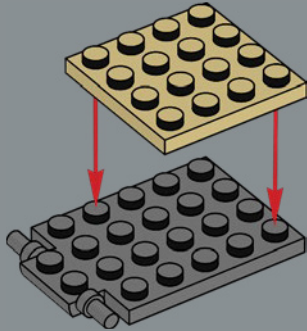

203

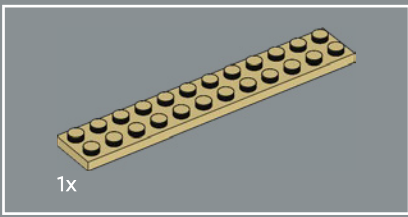
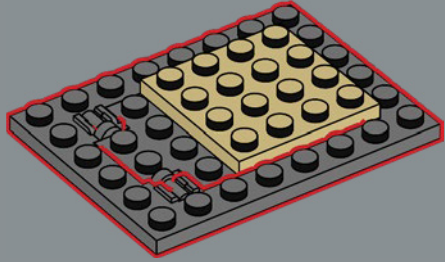

204

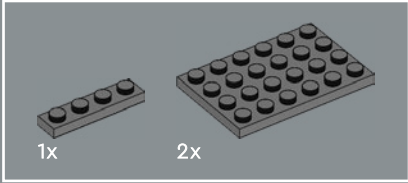
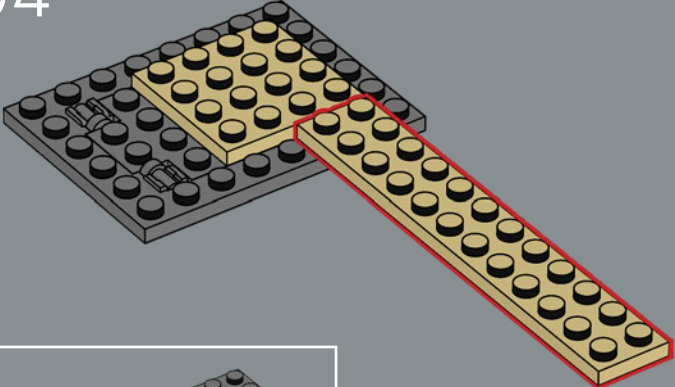

205

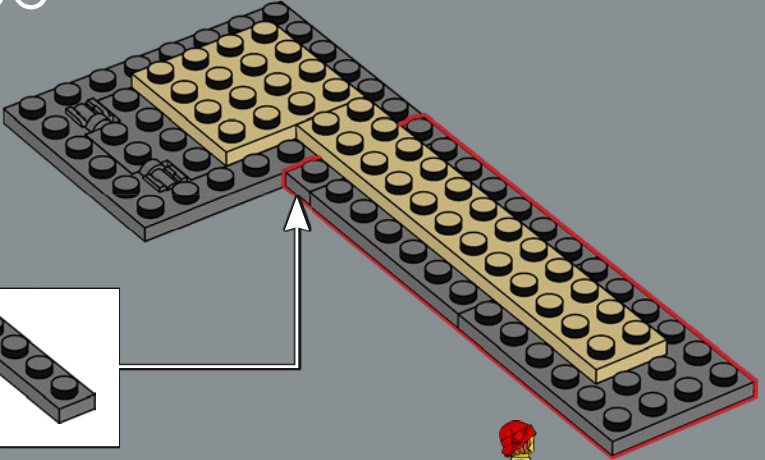

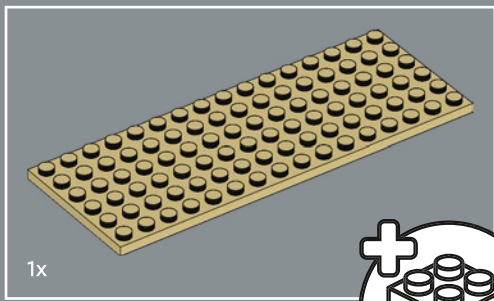

1x

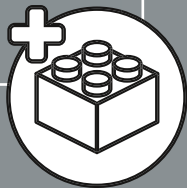

206

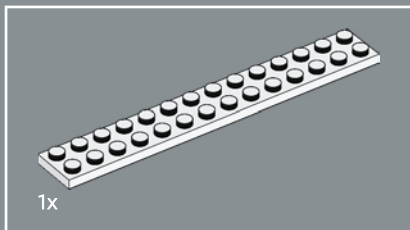
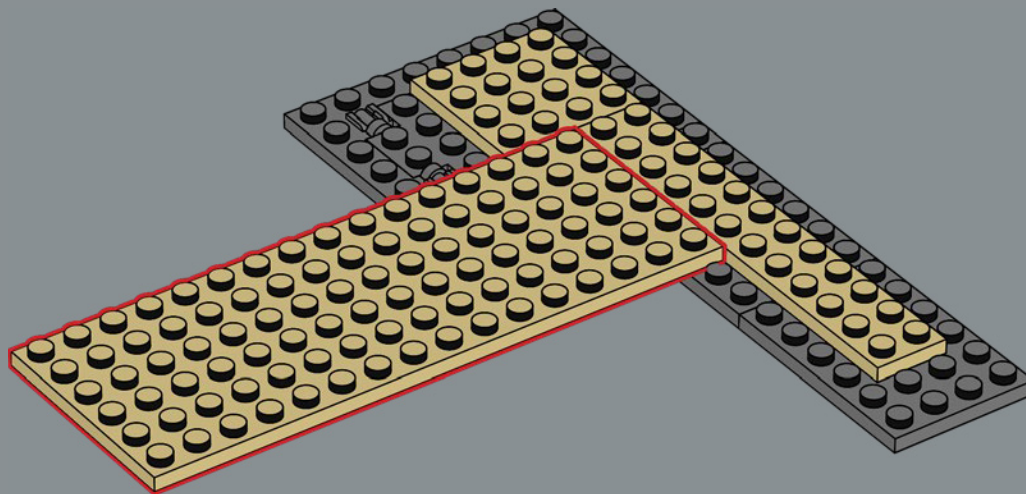

1x

207

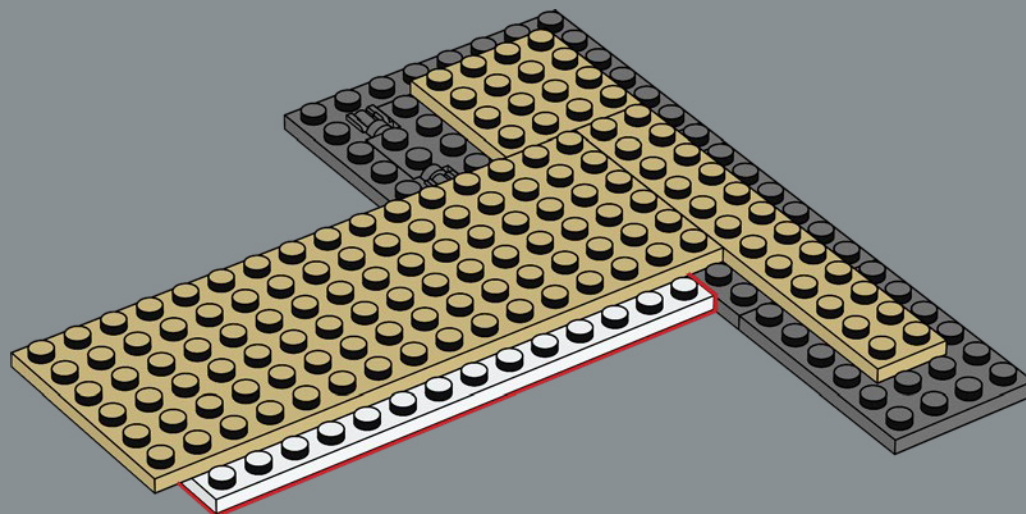

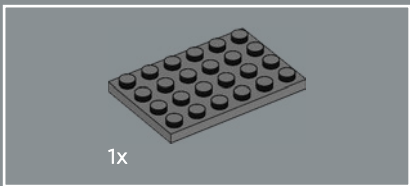

208

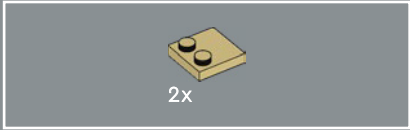
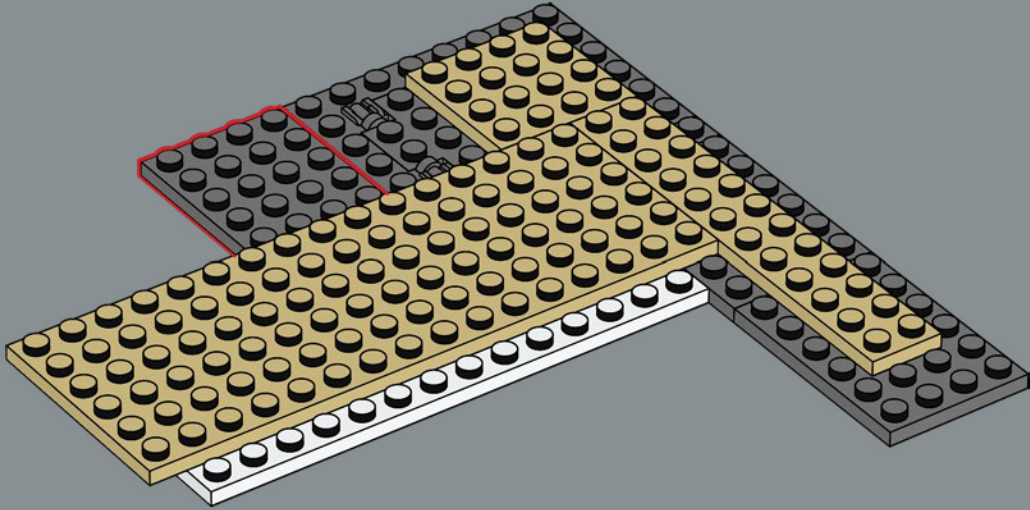

209

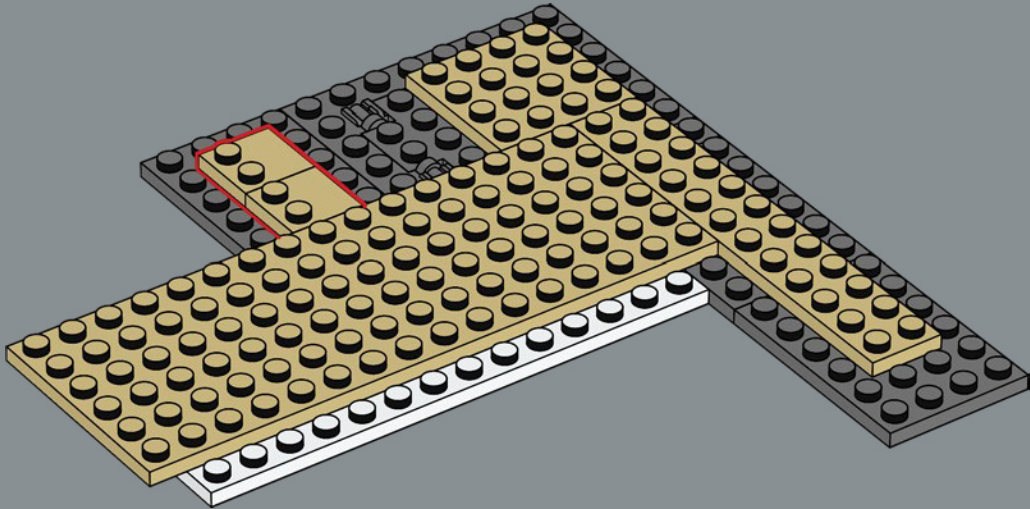



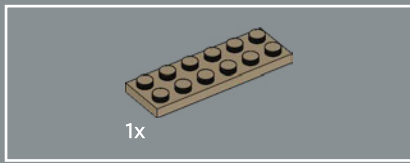

210

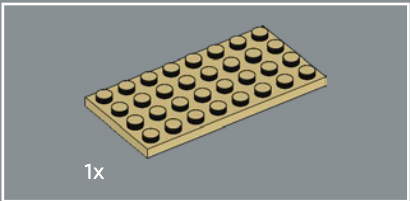
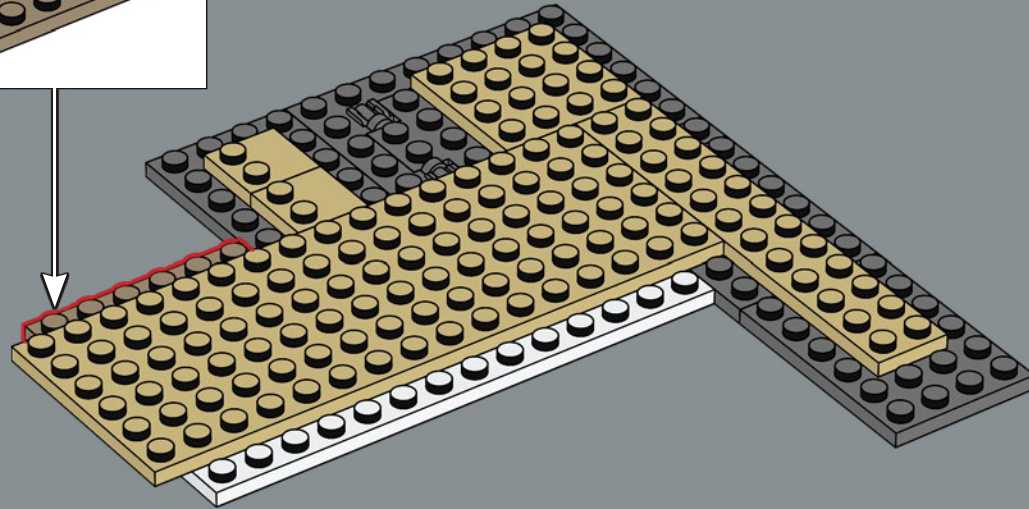
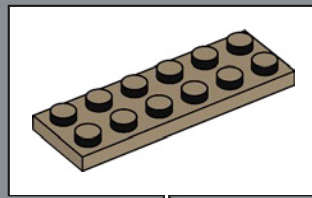

211

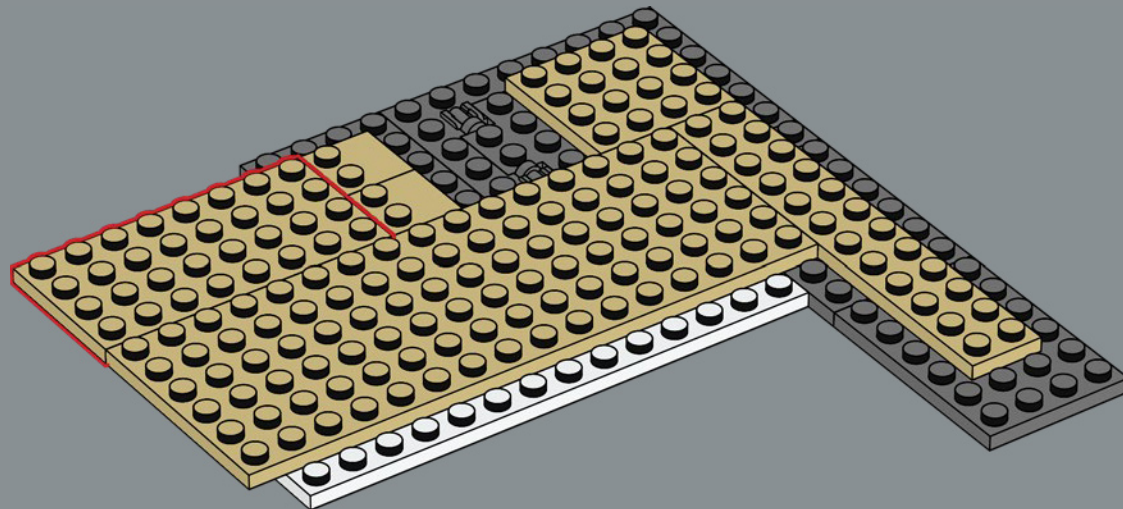

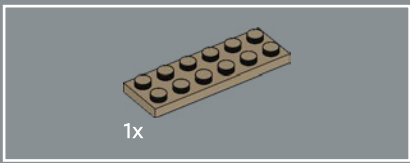

212

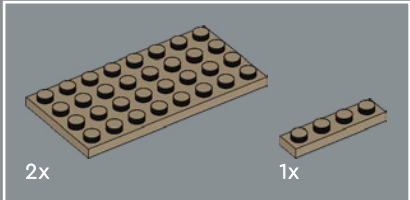
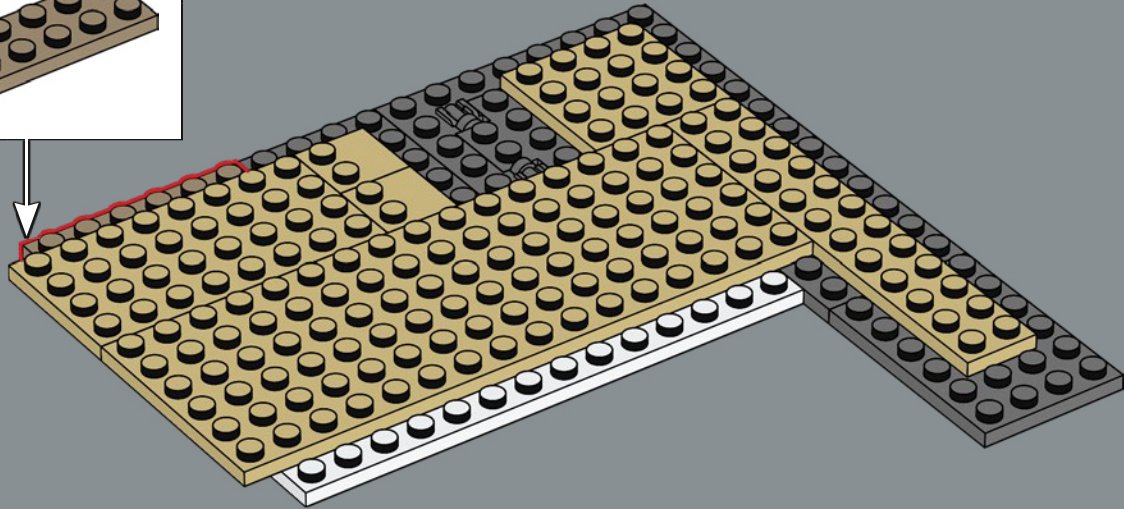
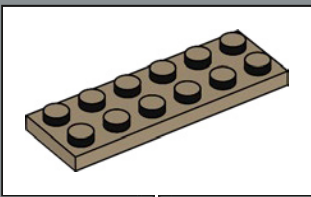

213

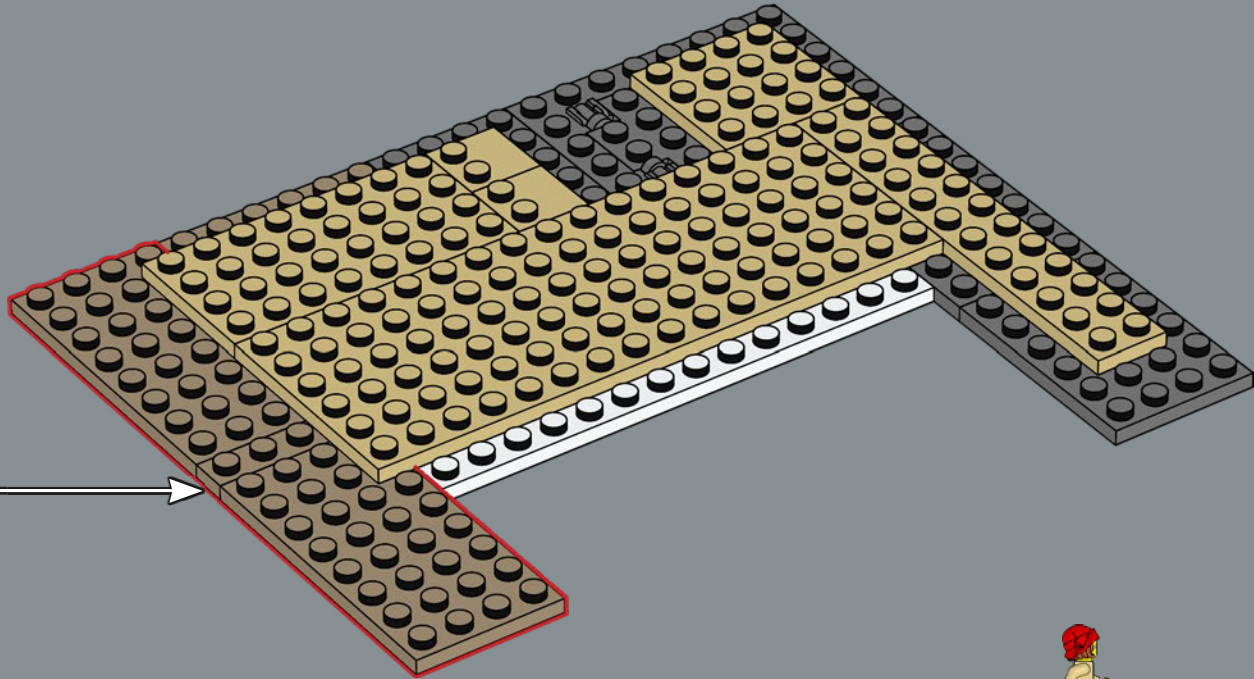
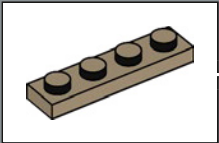

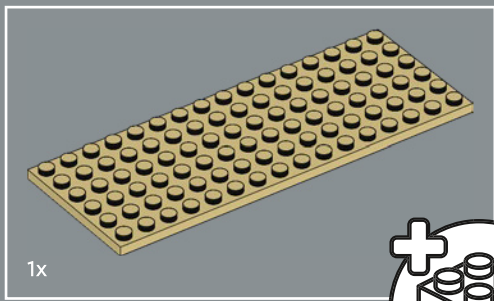

1x

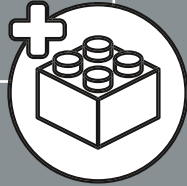

214

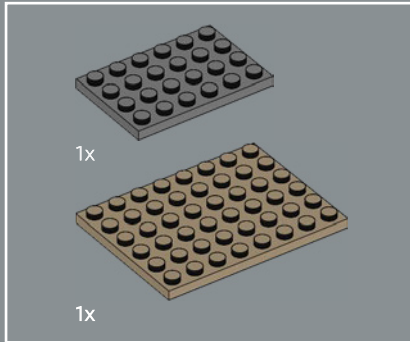
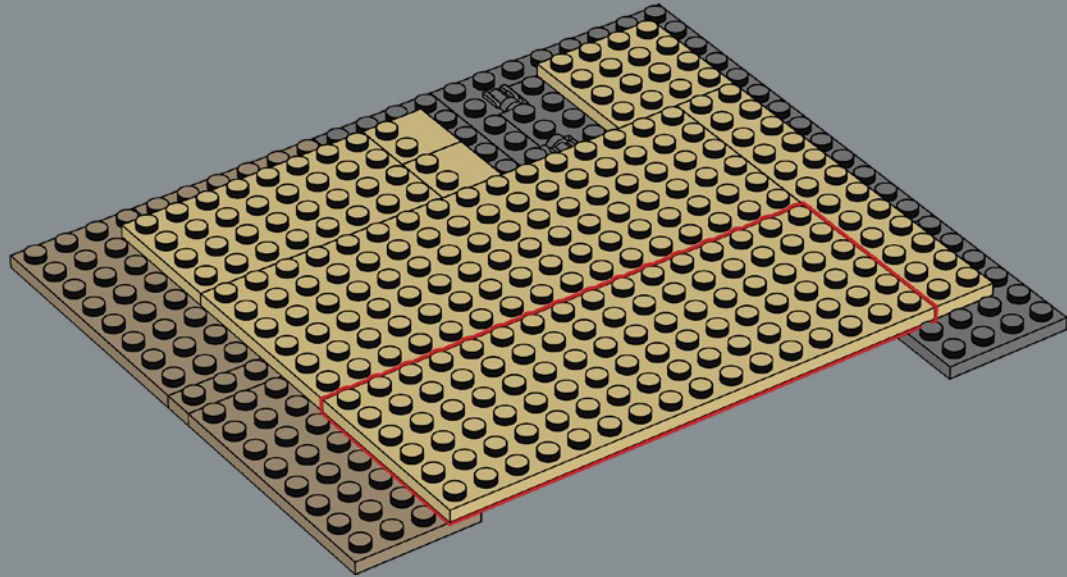

1x

1x

215

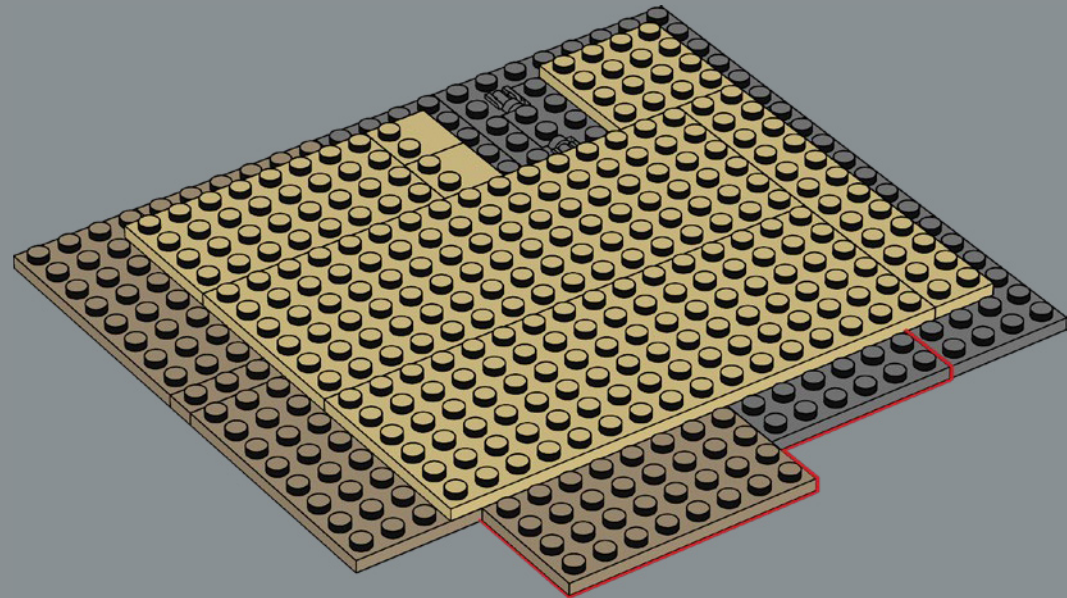

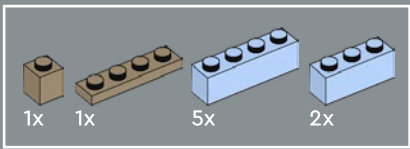

216

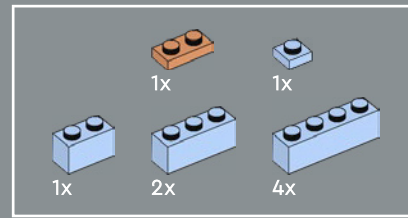
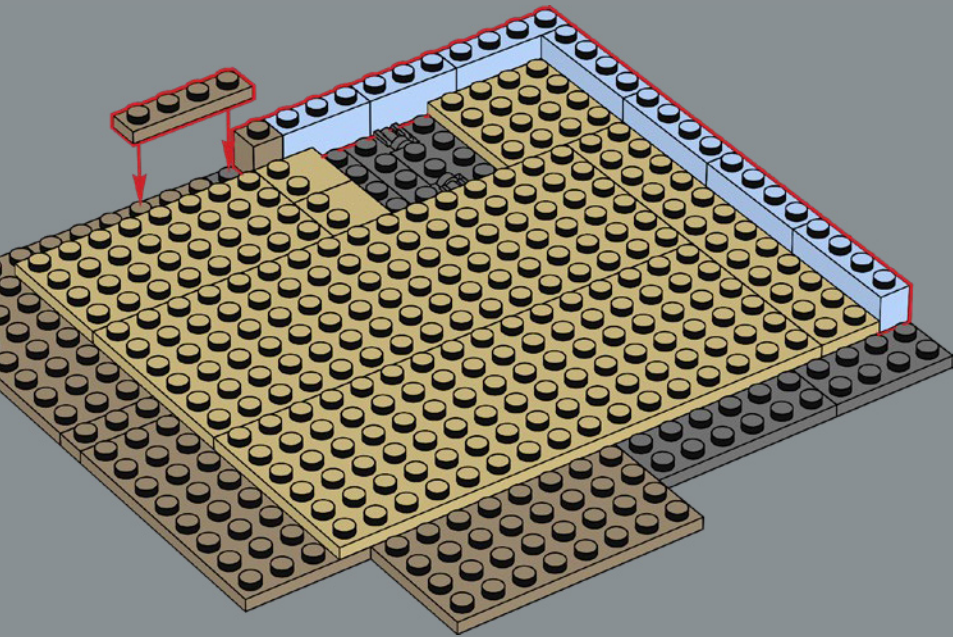

217

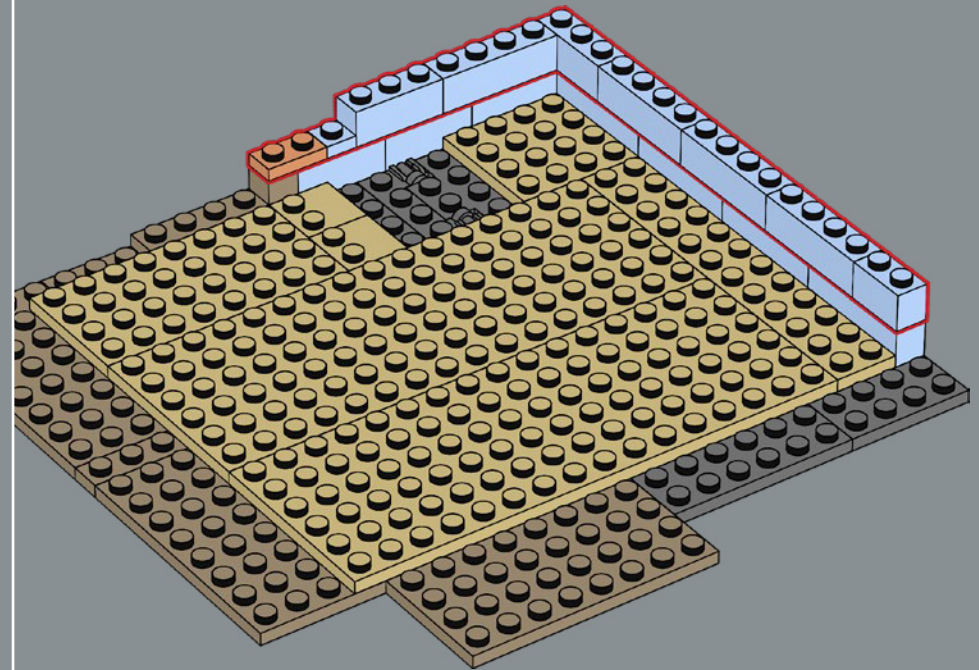

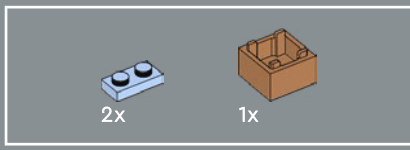

218

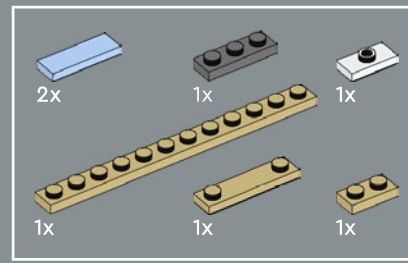
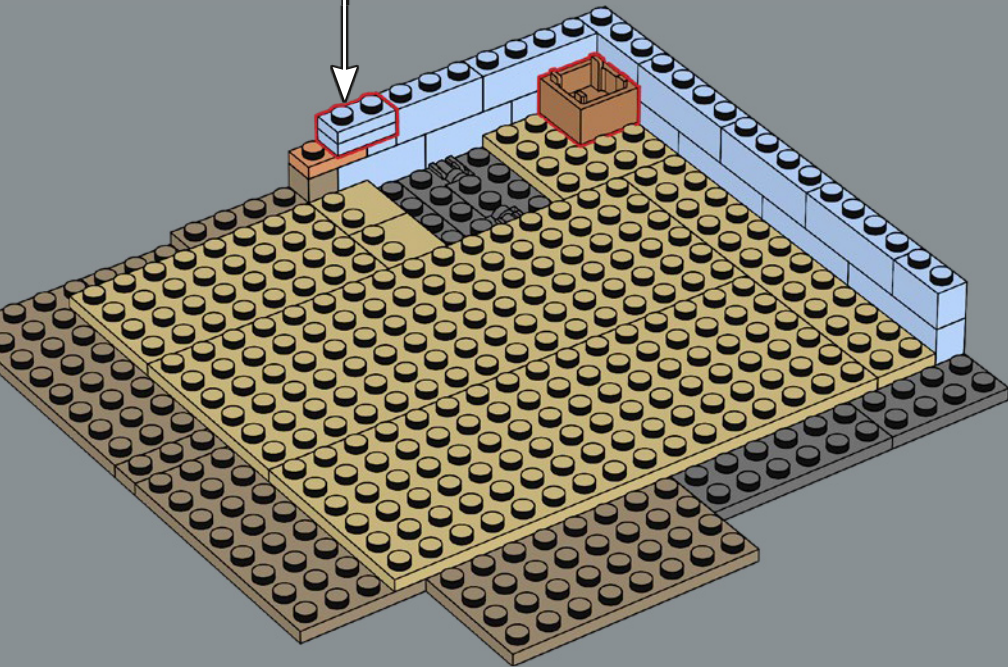
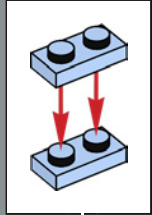

219

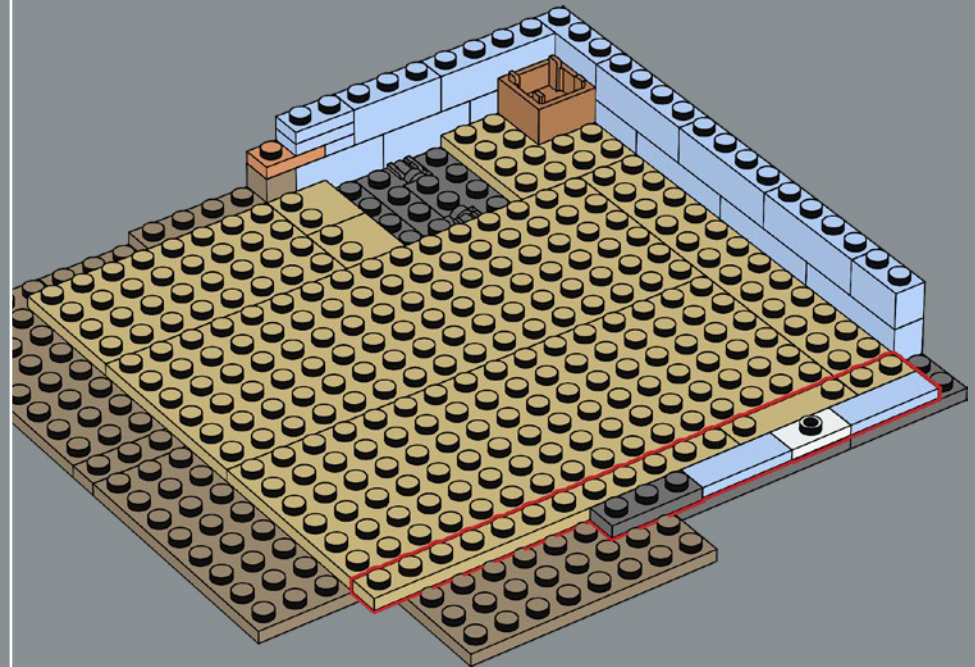

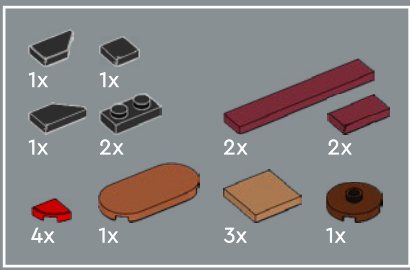

220

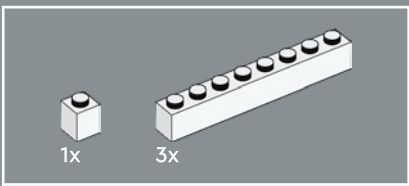
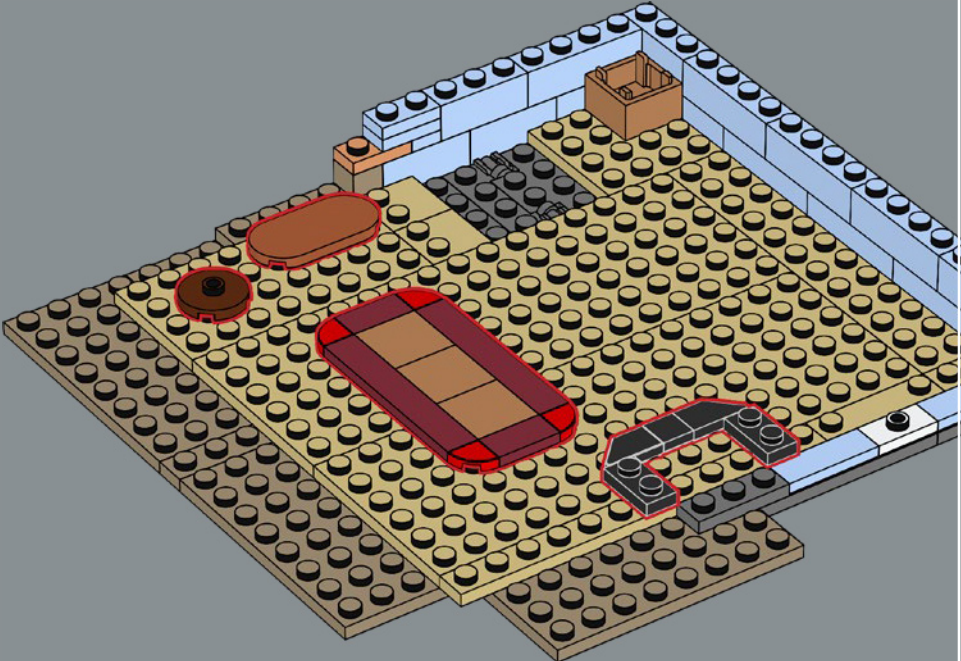

221

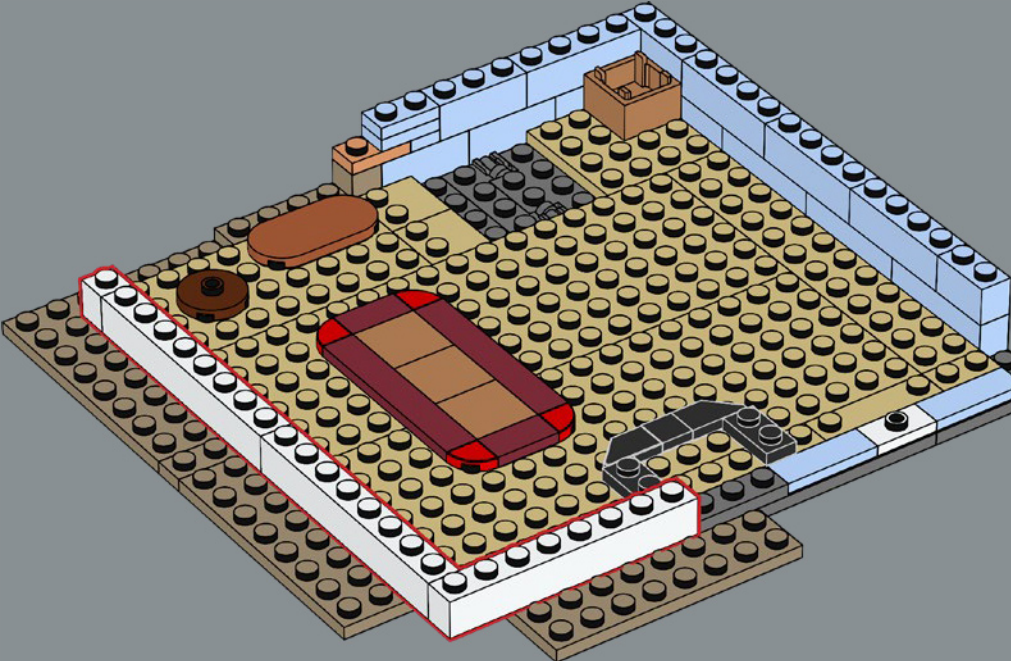

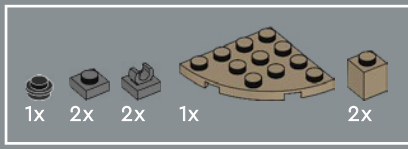

222

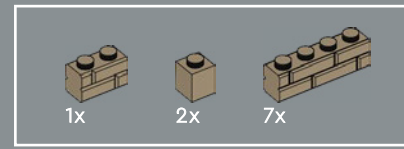
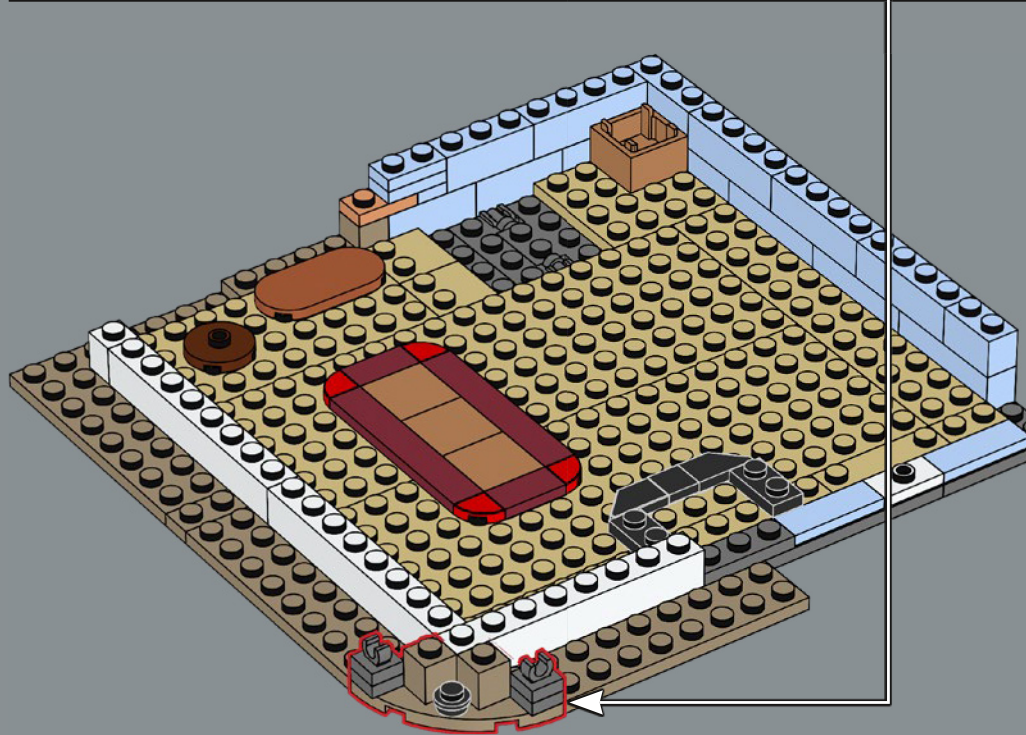
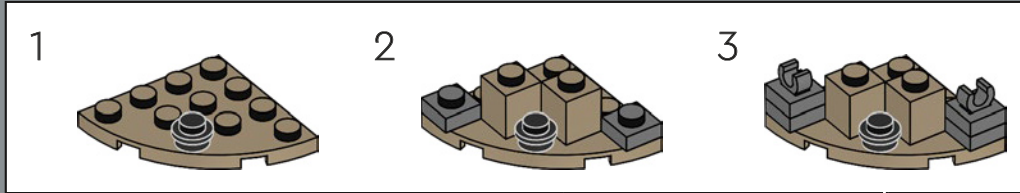

223

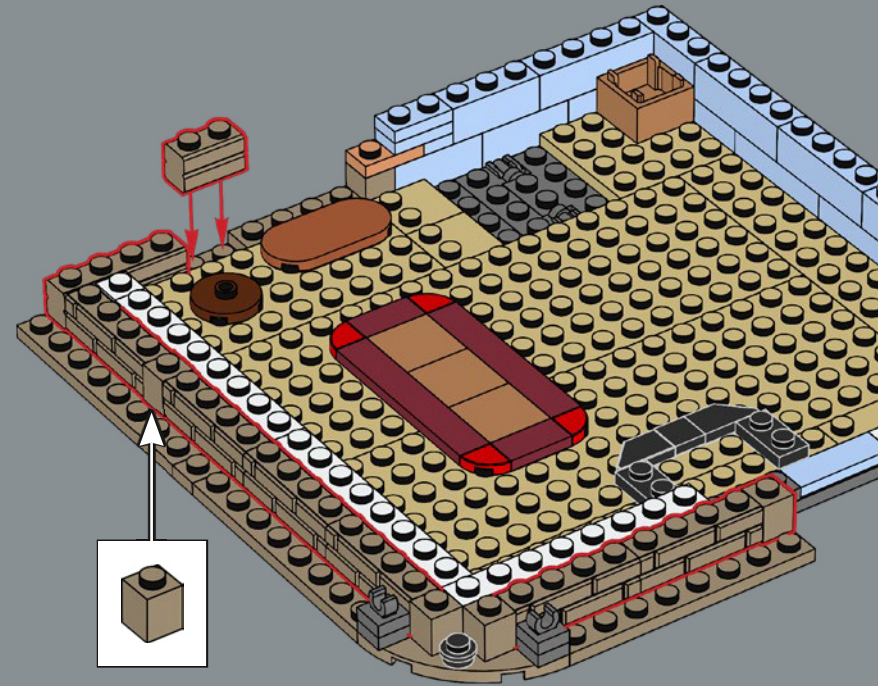

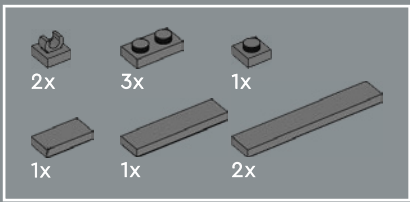

224

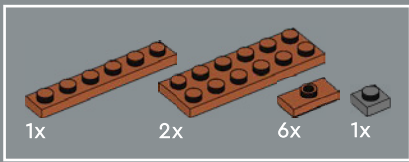
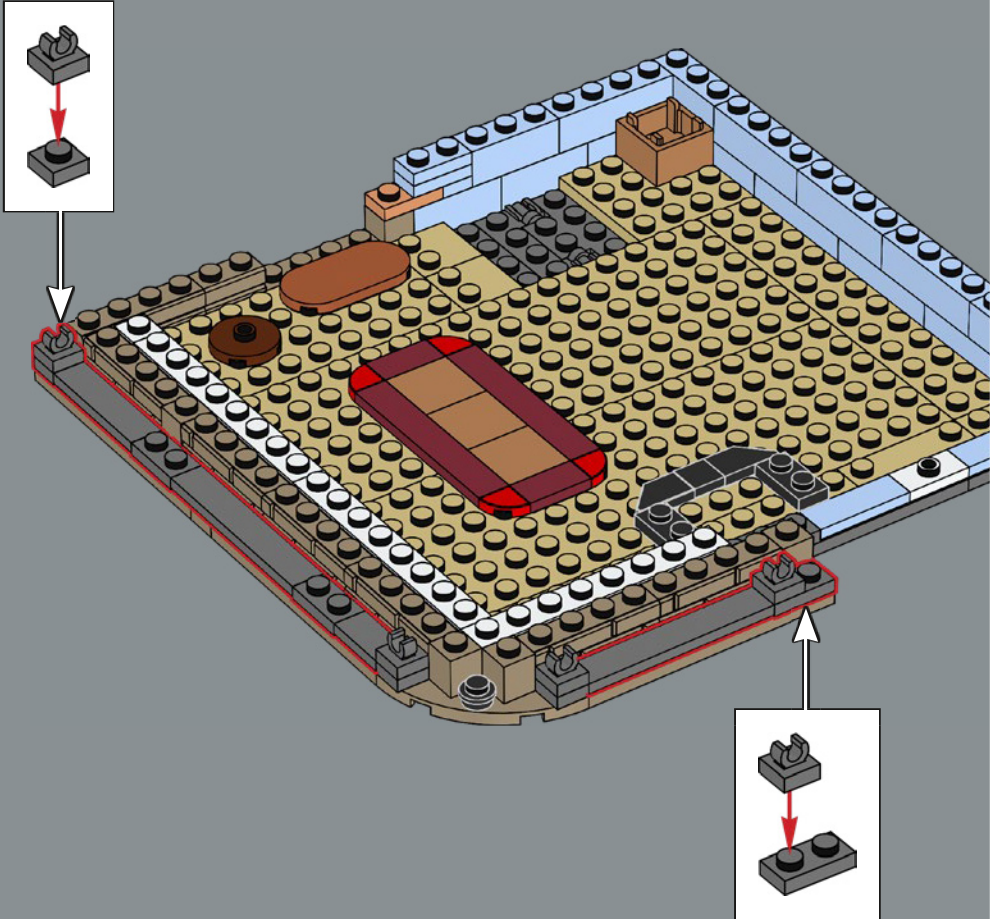

225

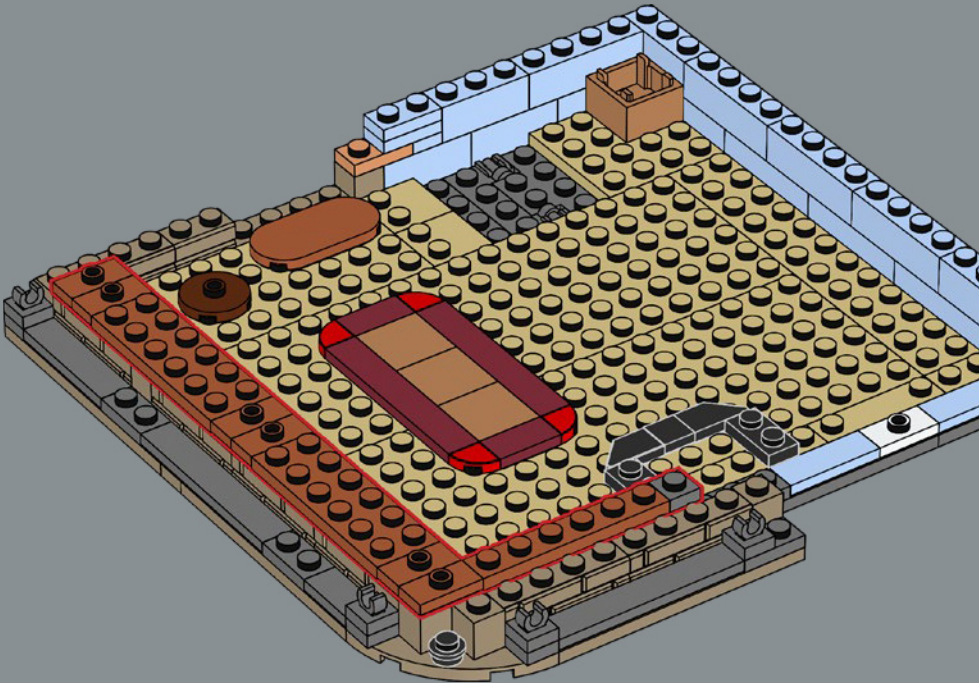



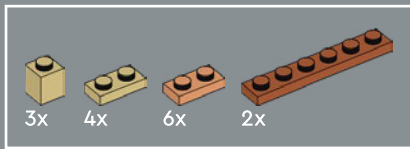

226

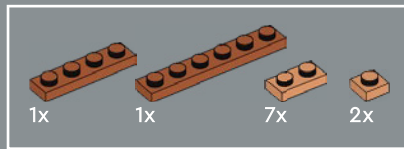
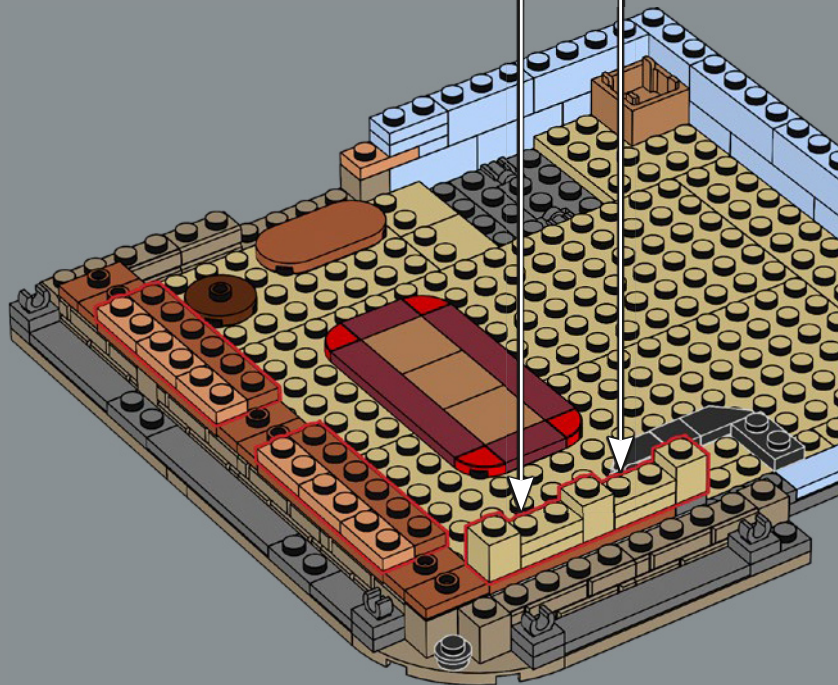
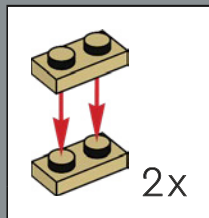

227

1

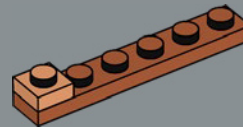

2

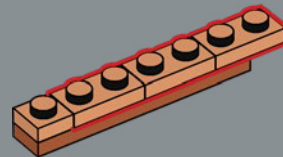

3

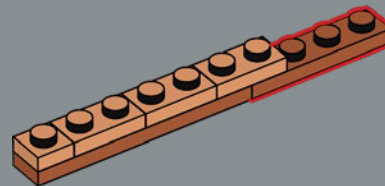

4

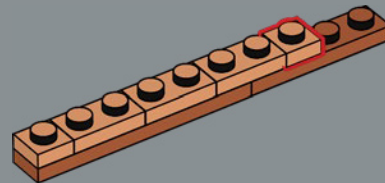

5

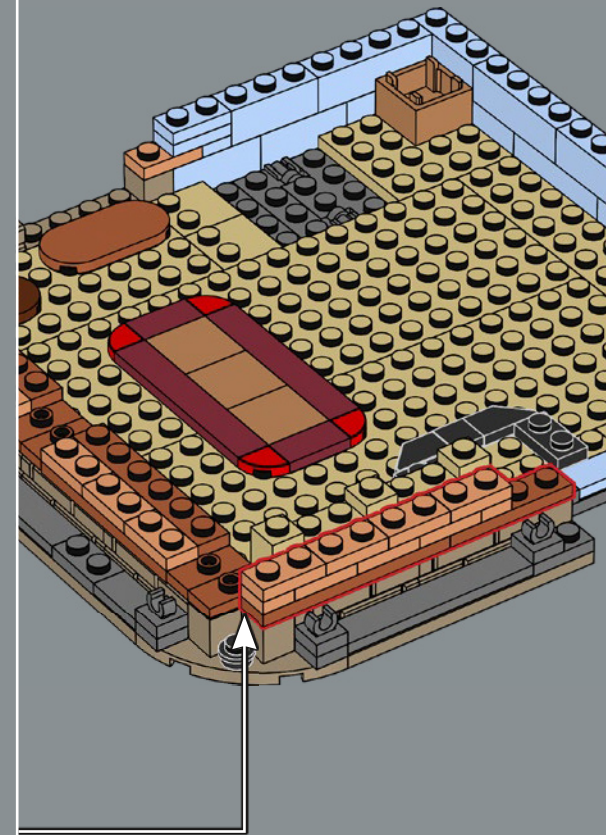
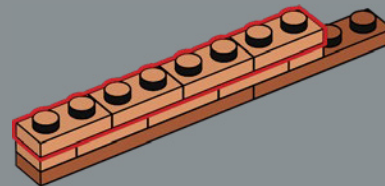

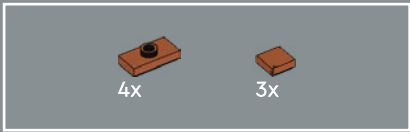

228

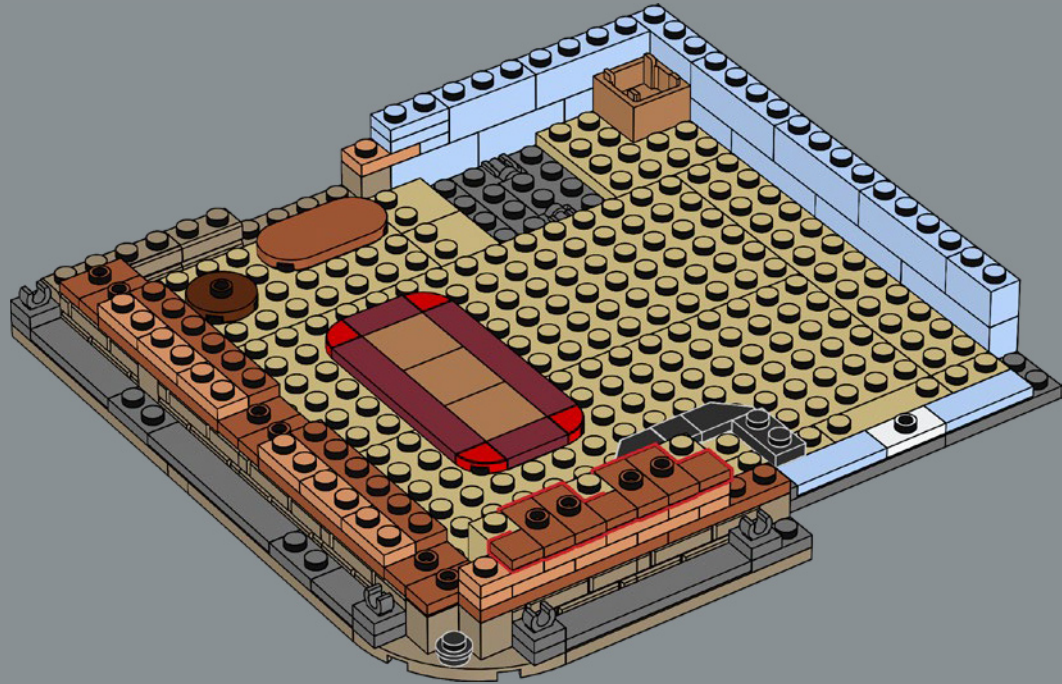

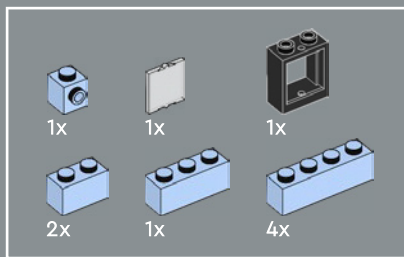

229

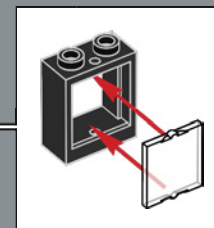
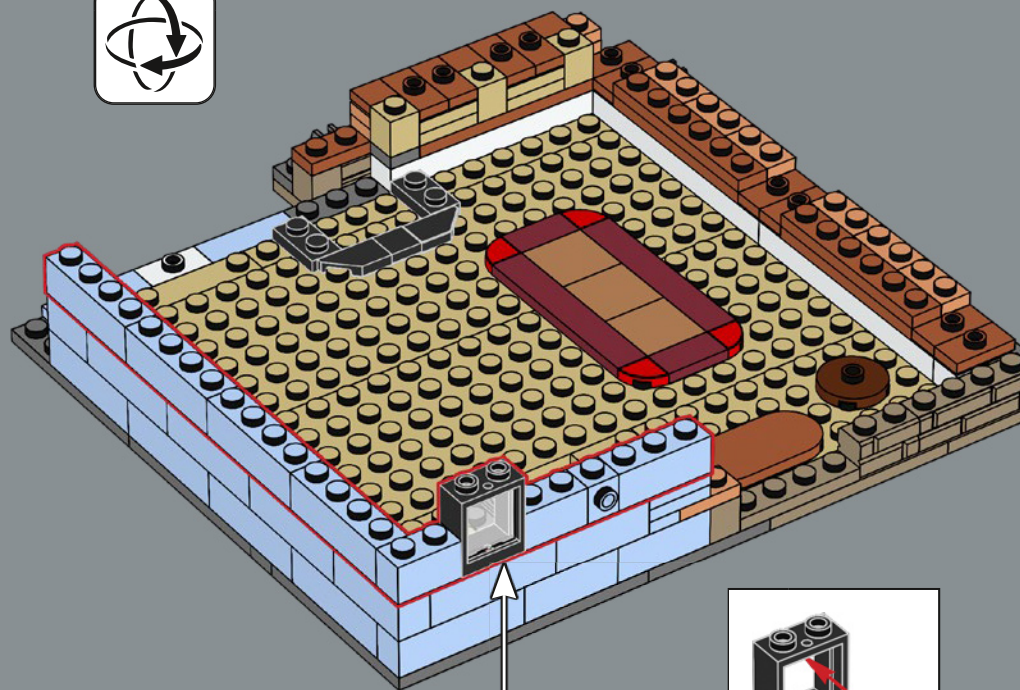

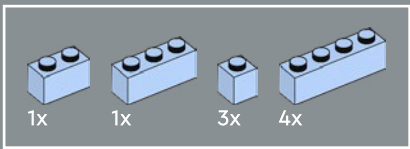

230

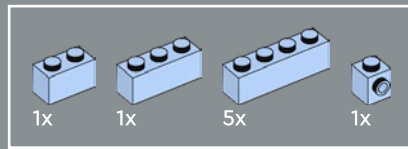
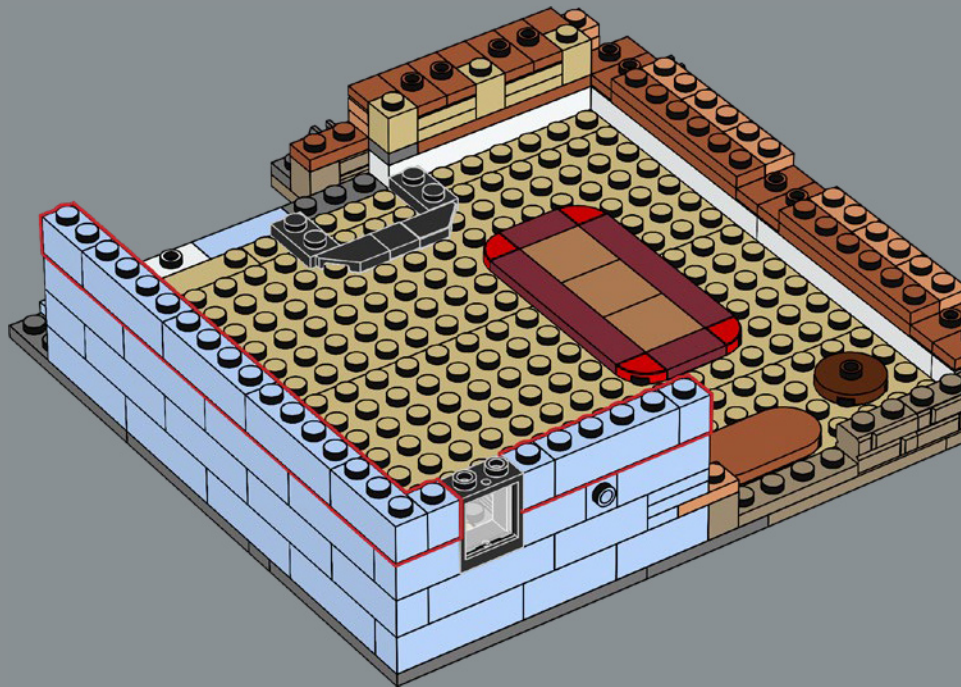

231

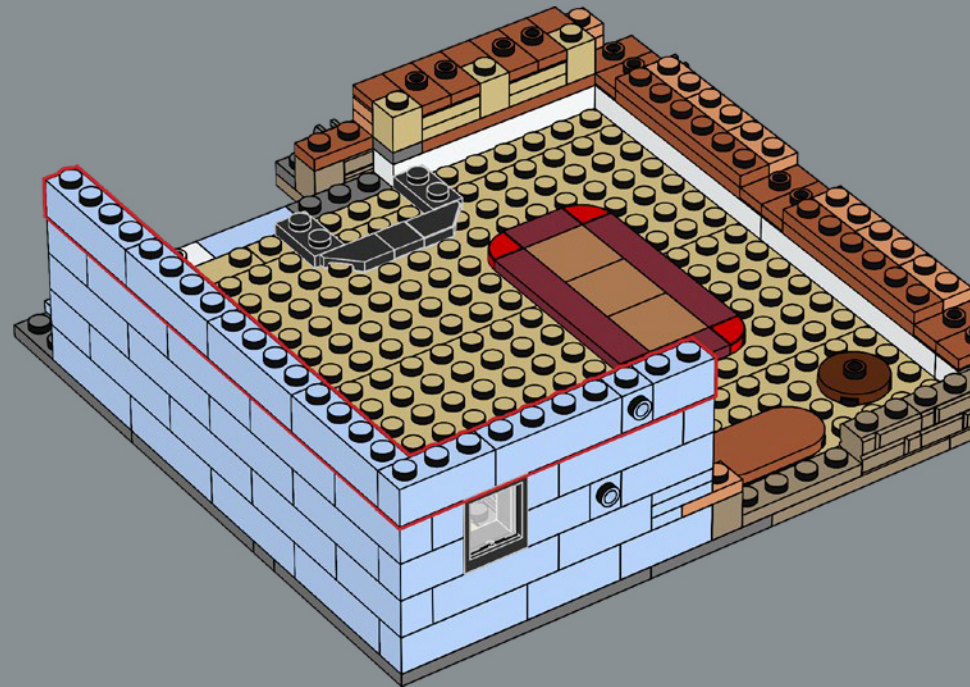

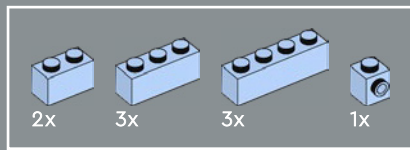

232

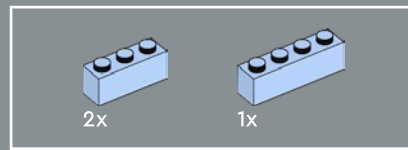
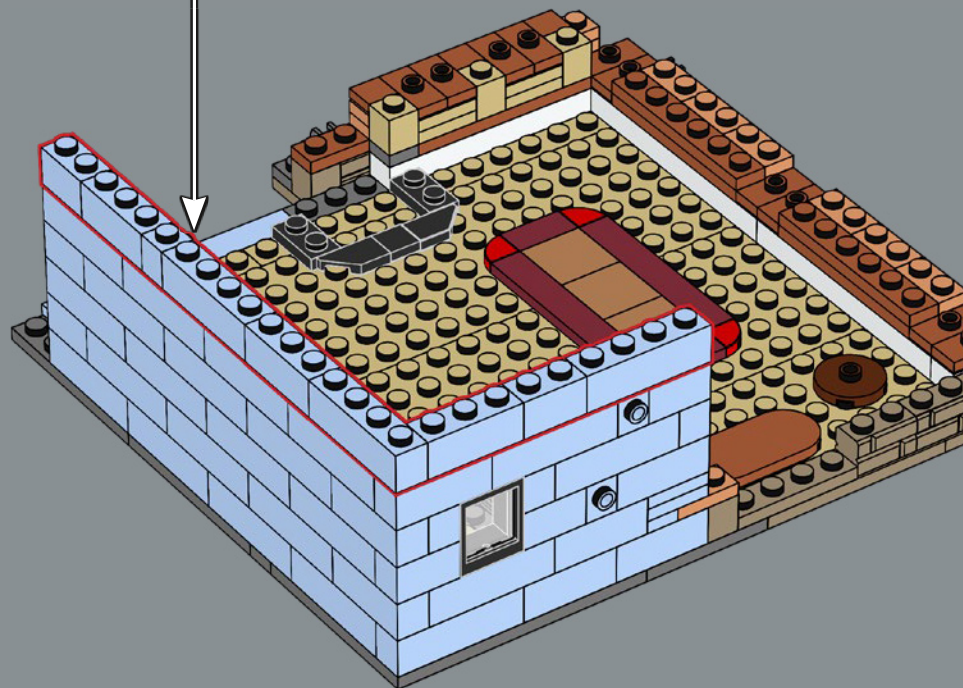
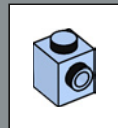

233

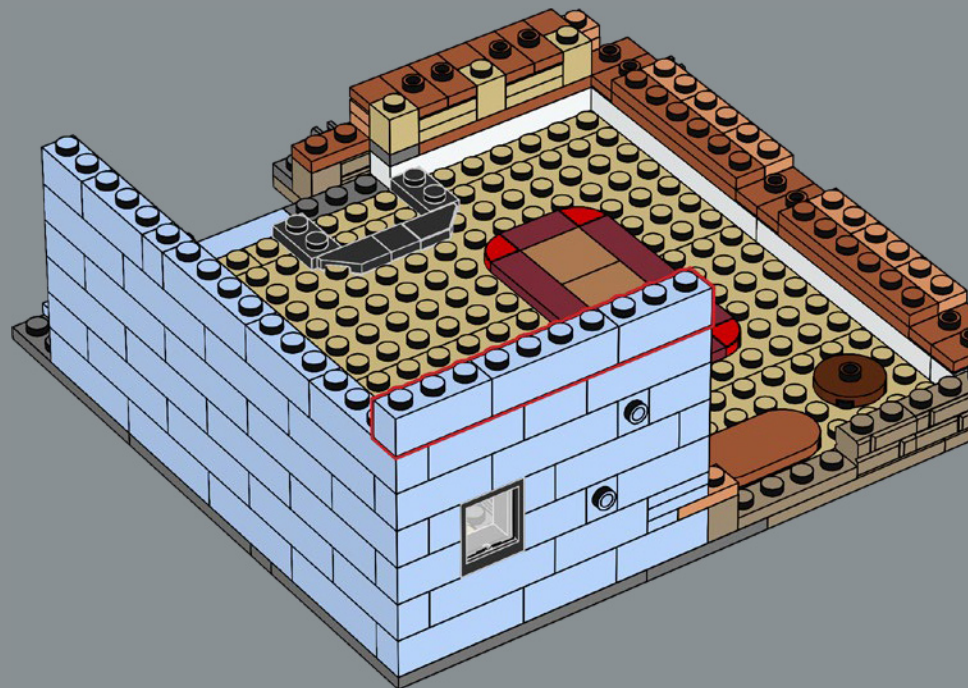

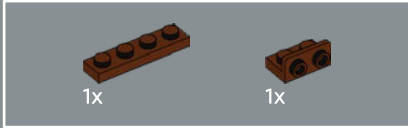
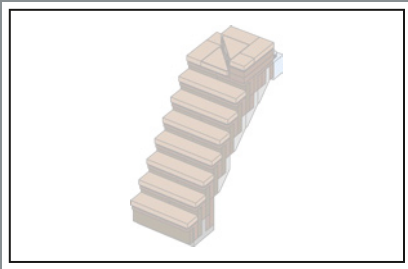

234

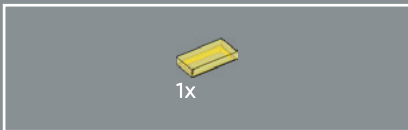
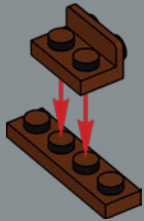

235

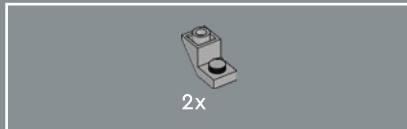
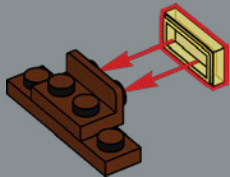

236

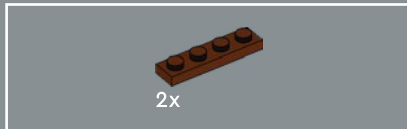
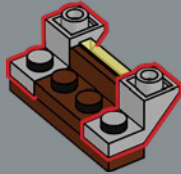

237

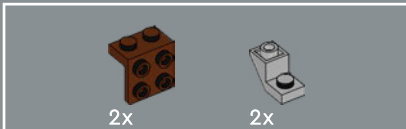
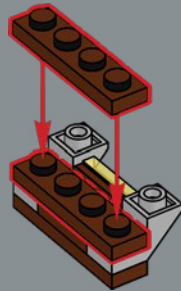

238

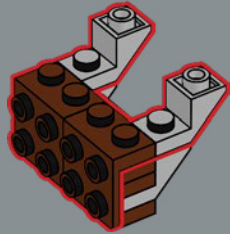

239

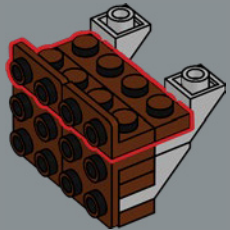

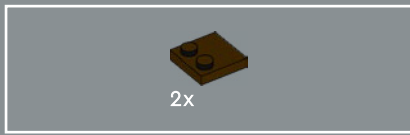

240

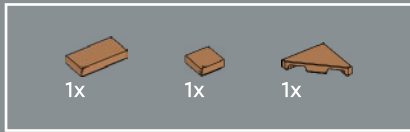
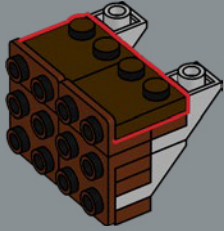

241

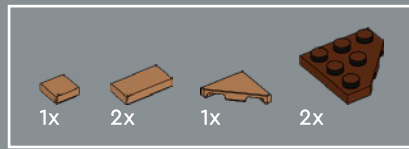
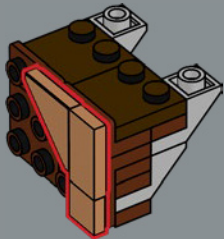

242

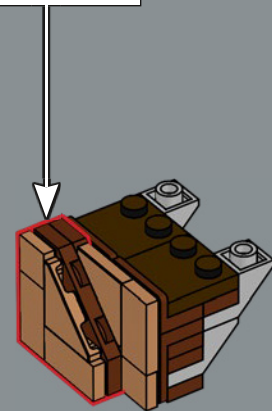
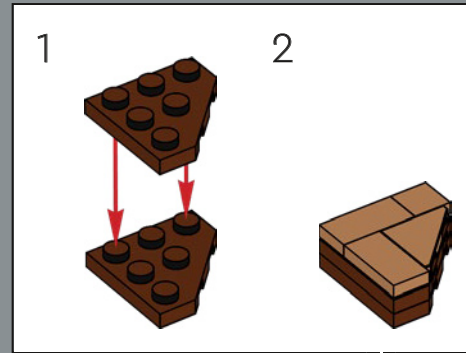

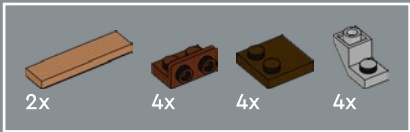
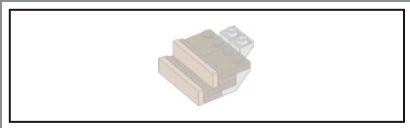

# 243

1

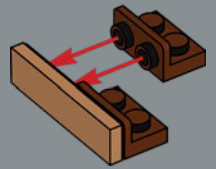

2

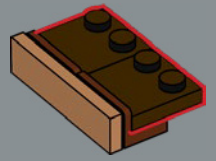

3

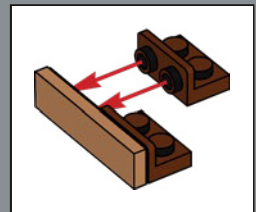
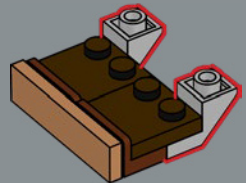

4

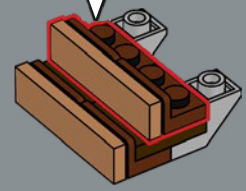

5

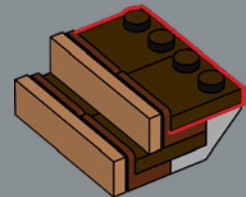

6

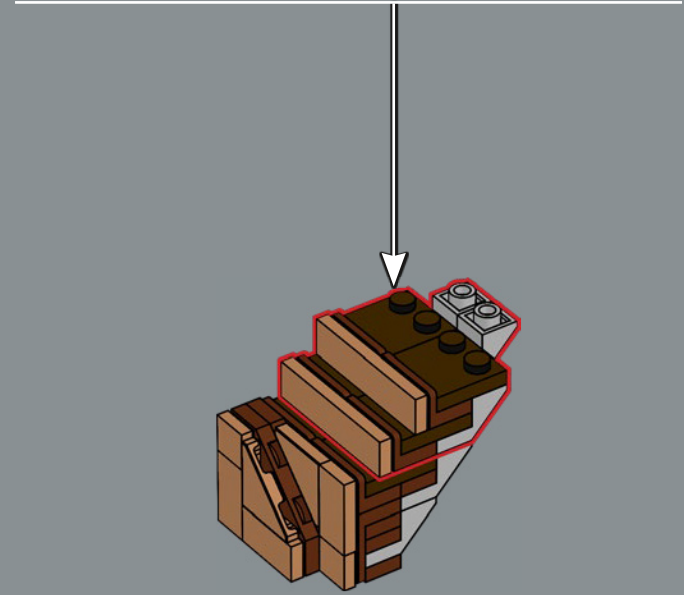
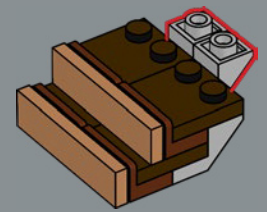



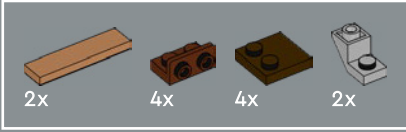
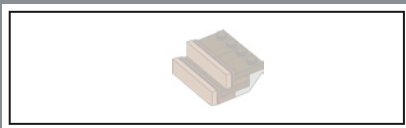

244

1

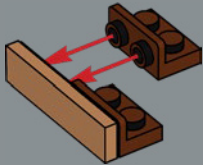

2

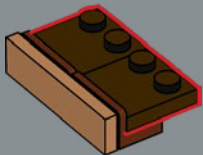

3

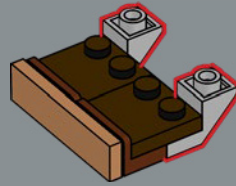

4

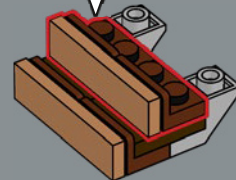
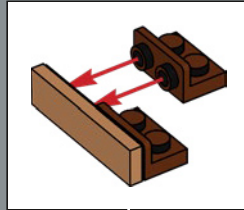

5

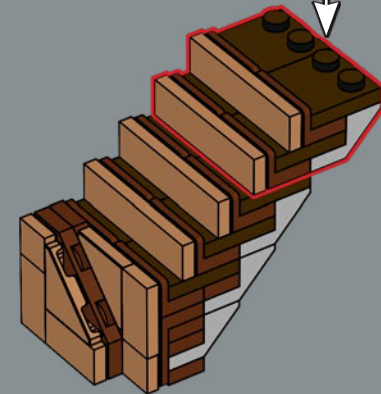
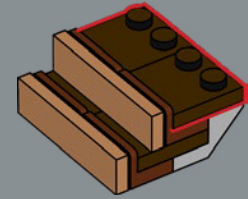

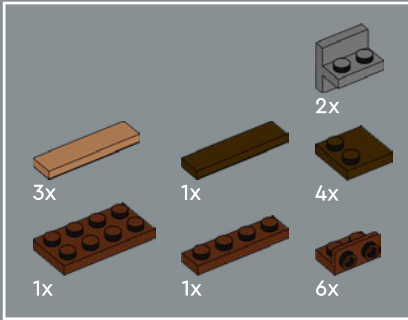
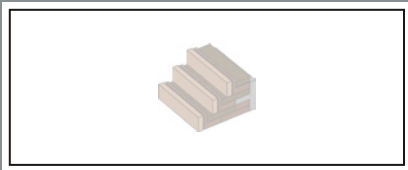

245

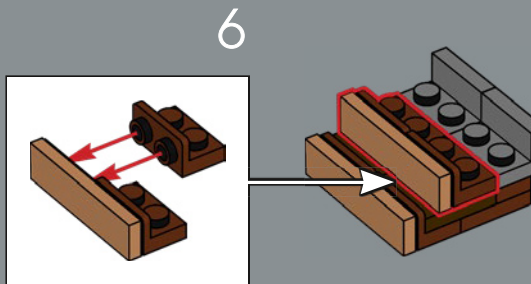
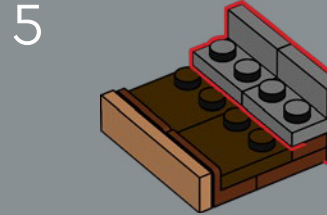
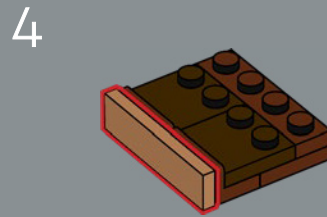
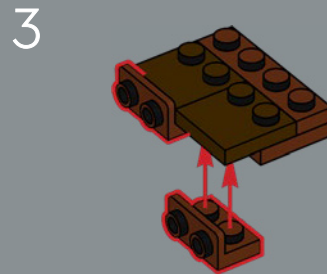
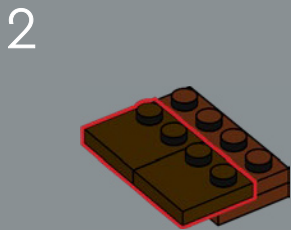
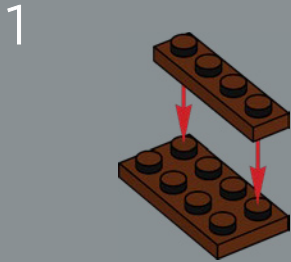

7

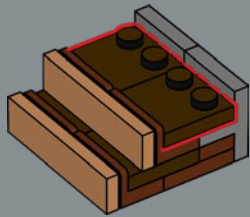

8

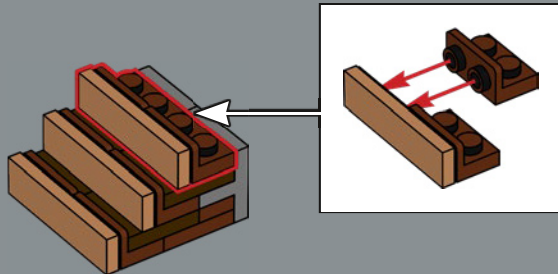

9

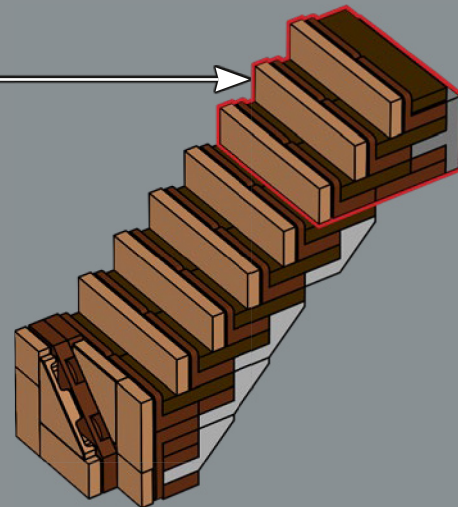
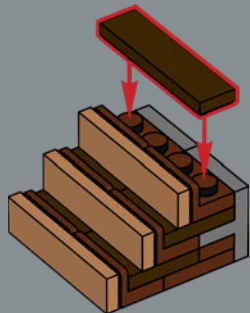



2x

246

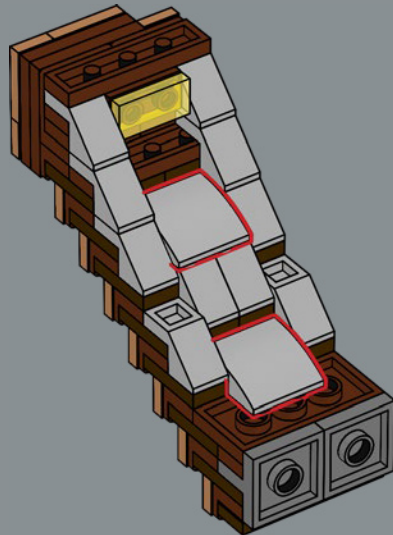

2x

247

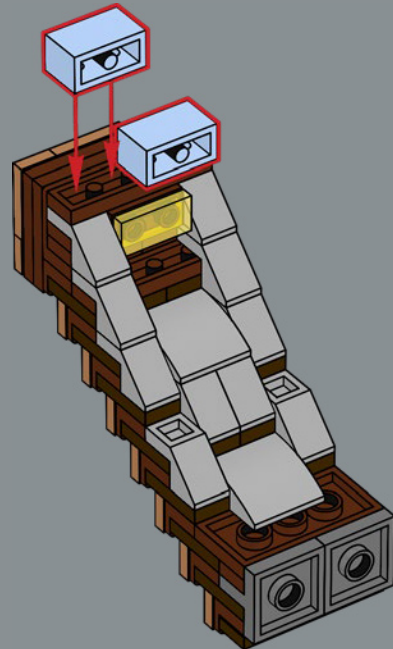

248

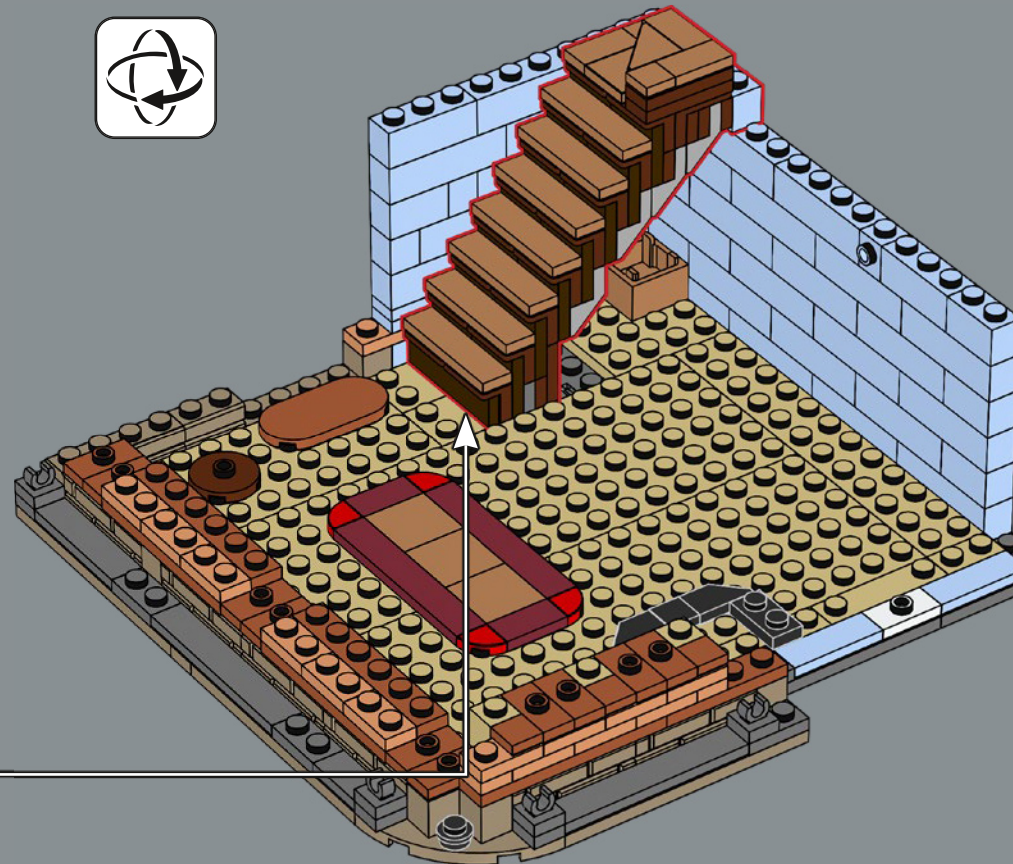

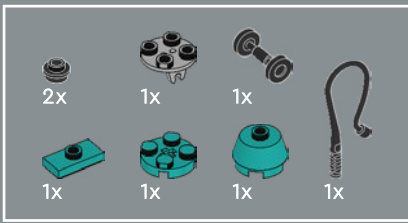

249

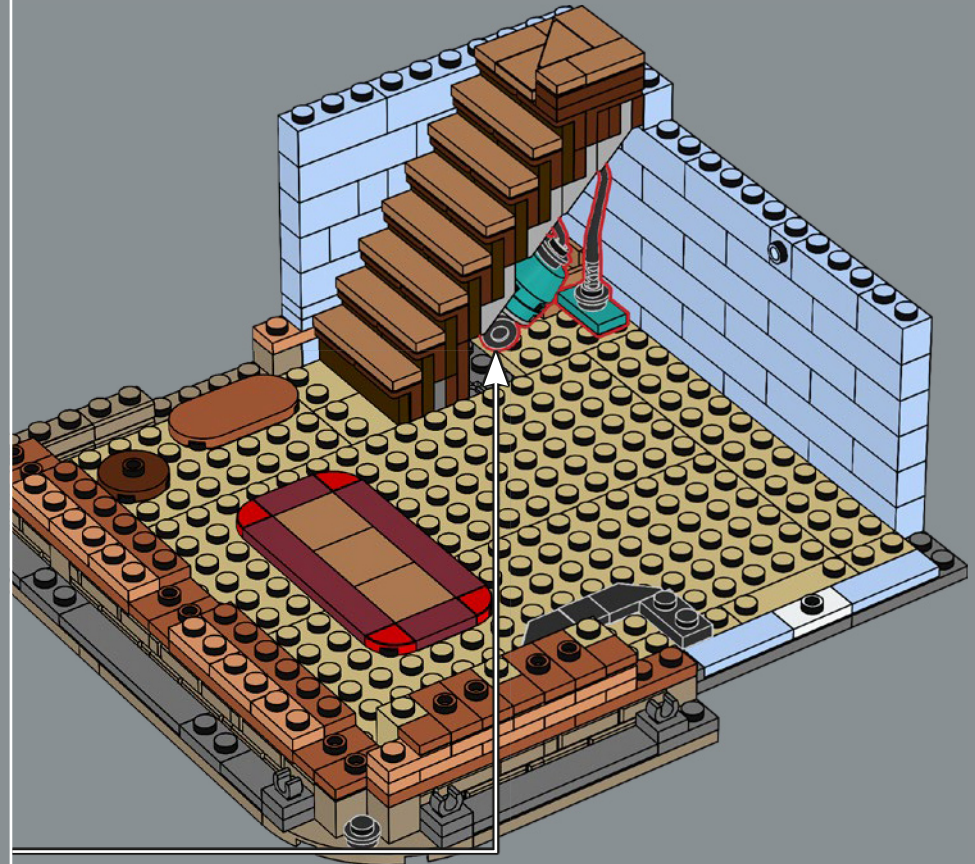
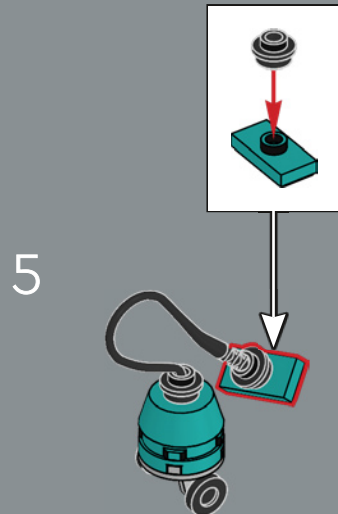
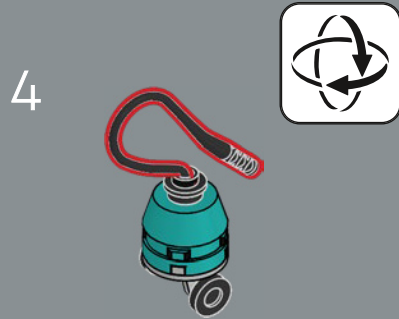
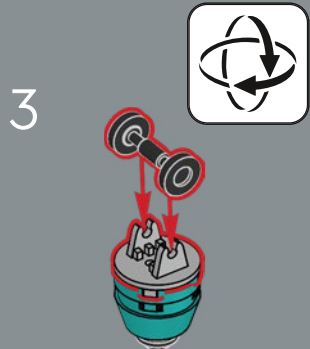
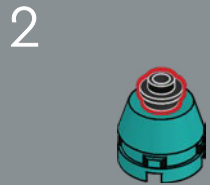
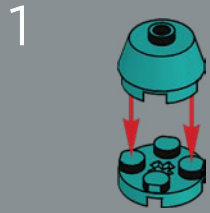

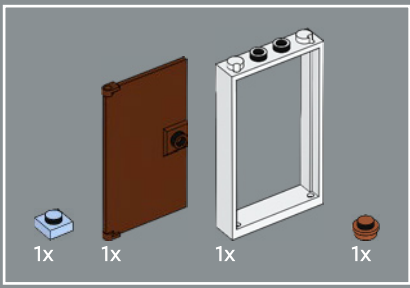

250

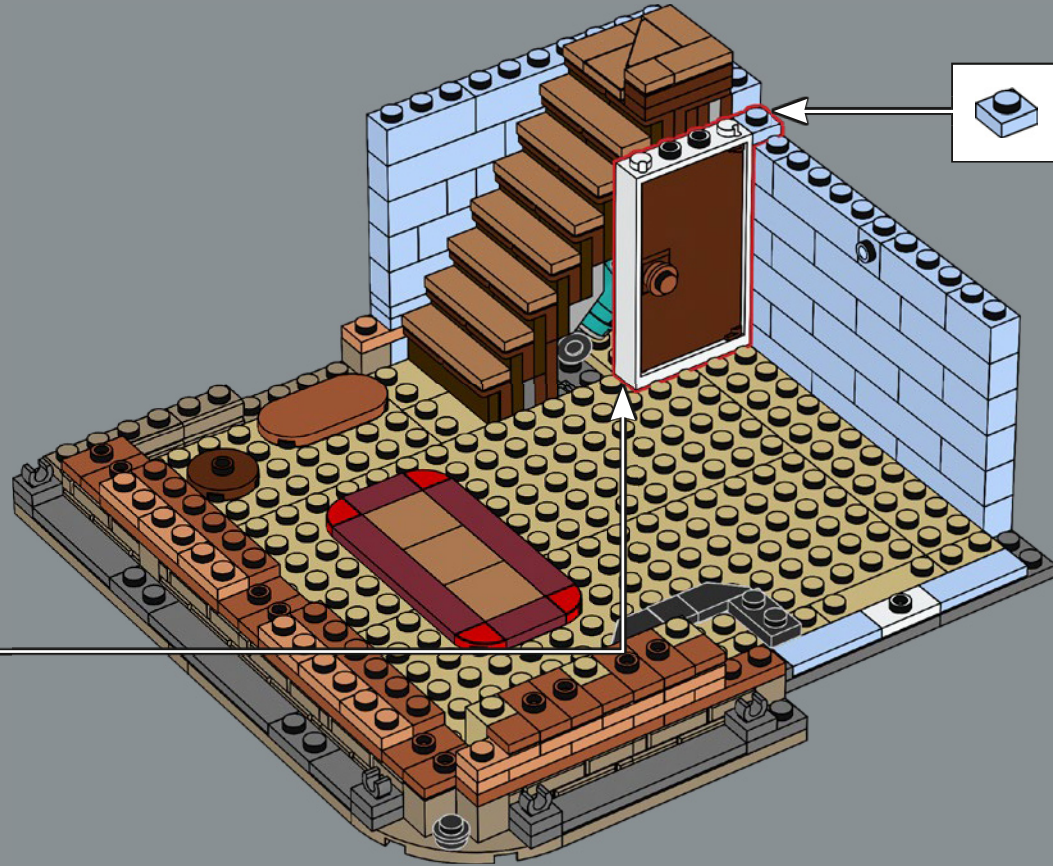
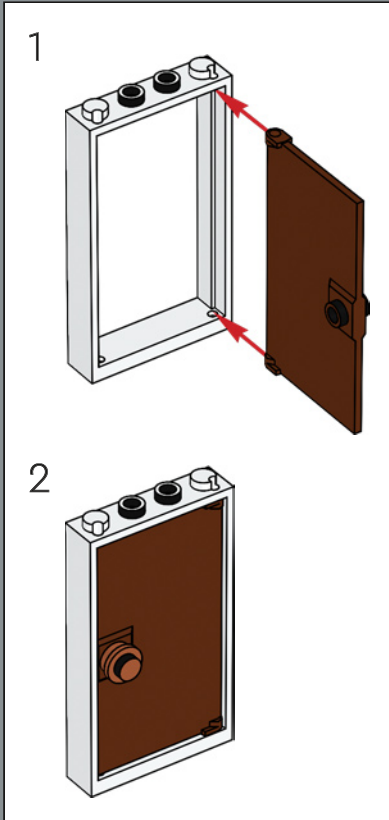

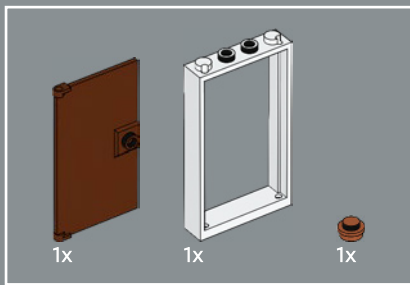

251

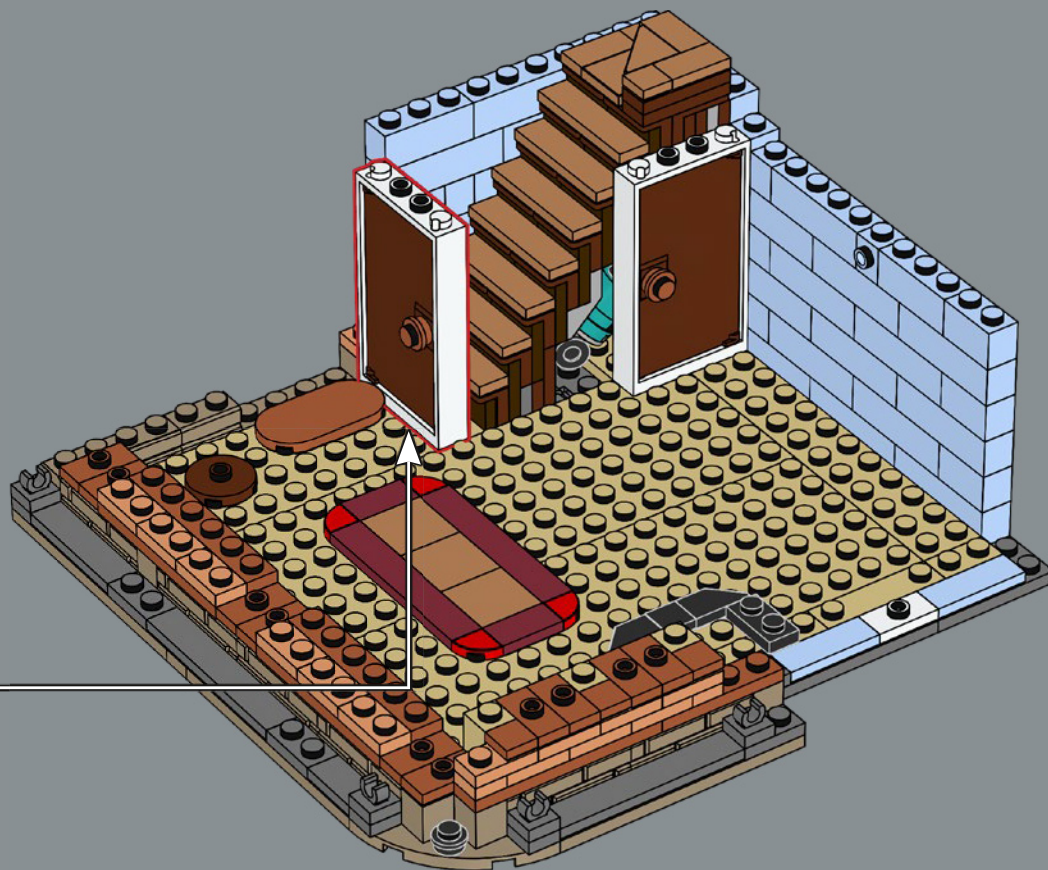
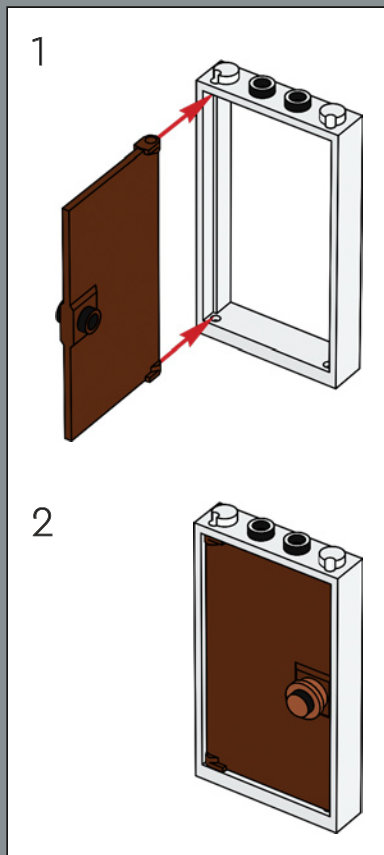

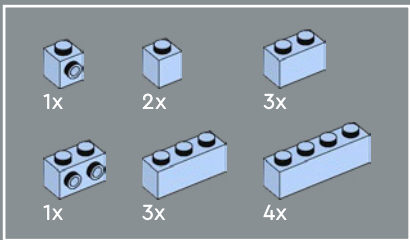

252

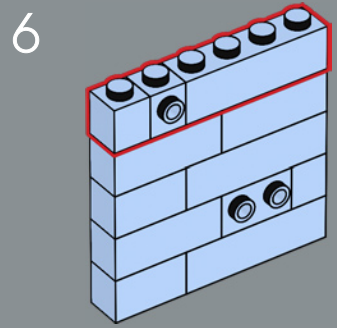
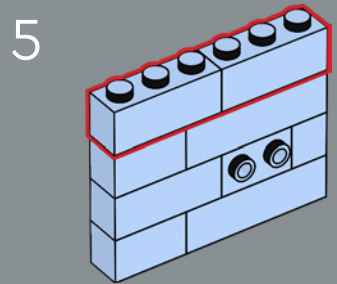
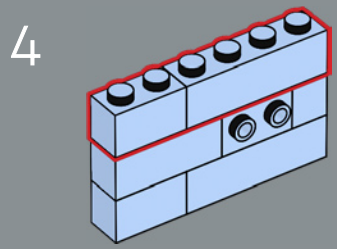
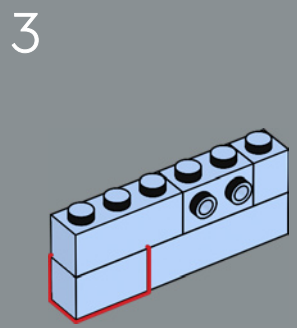
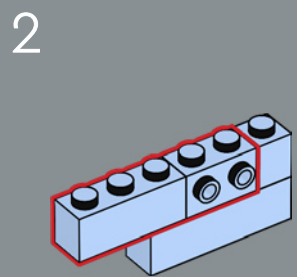
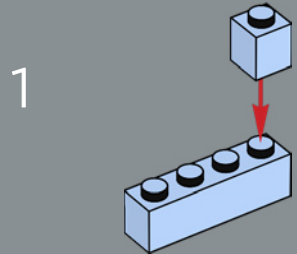

7

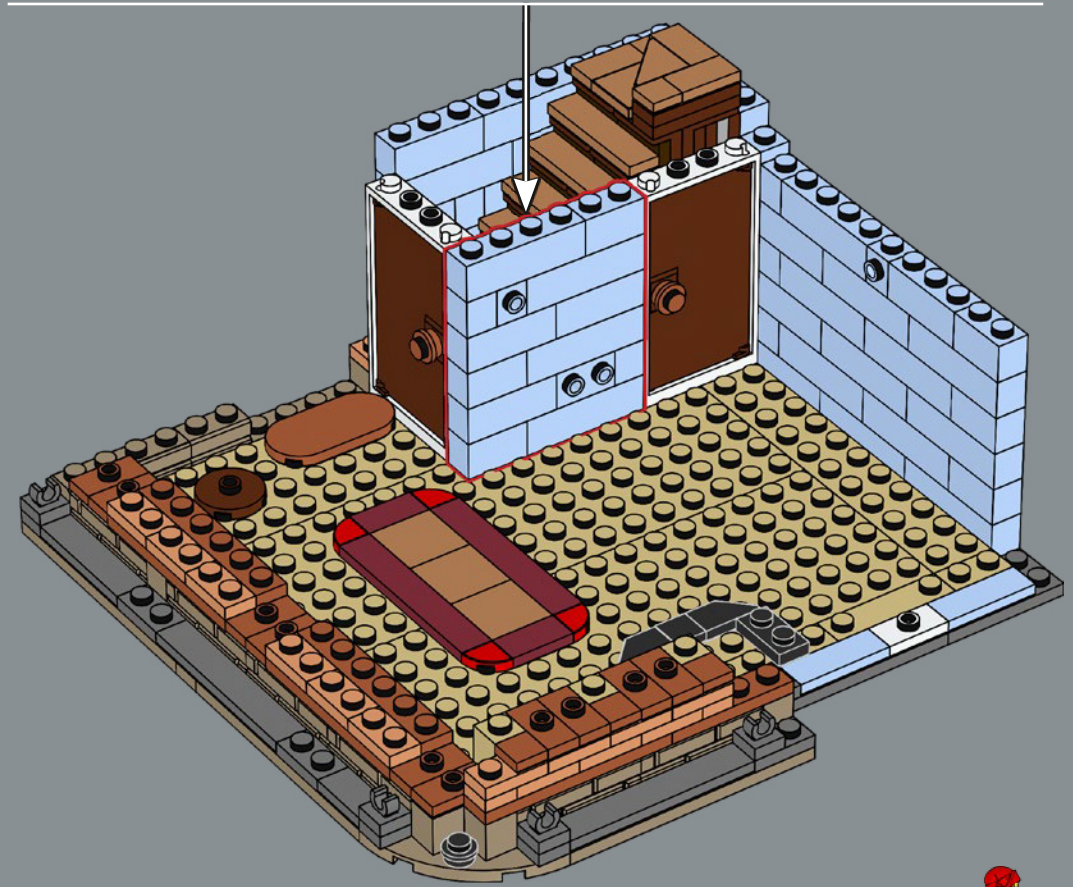
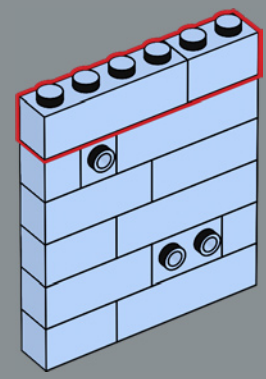



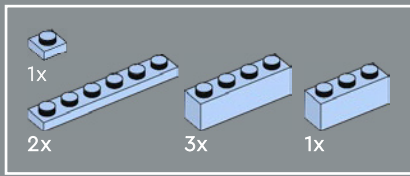

253

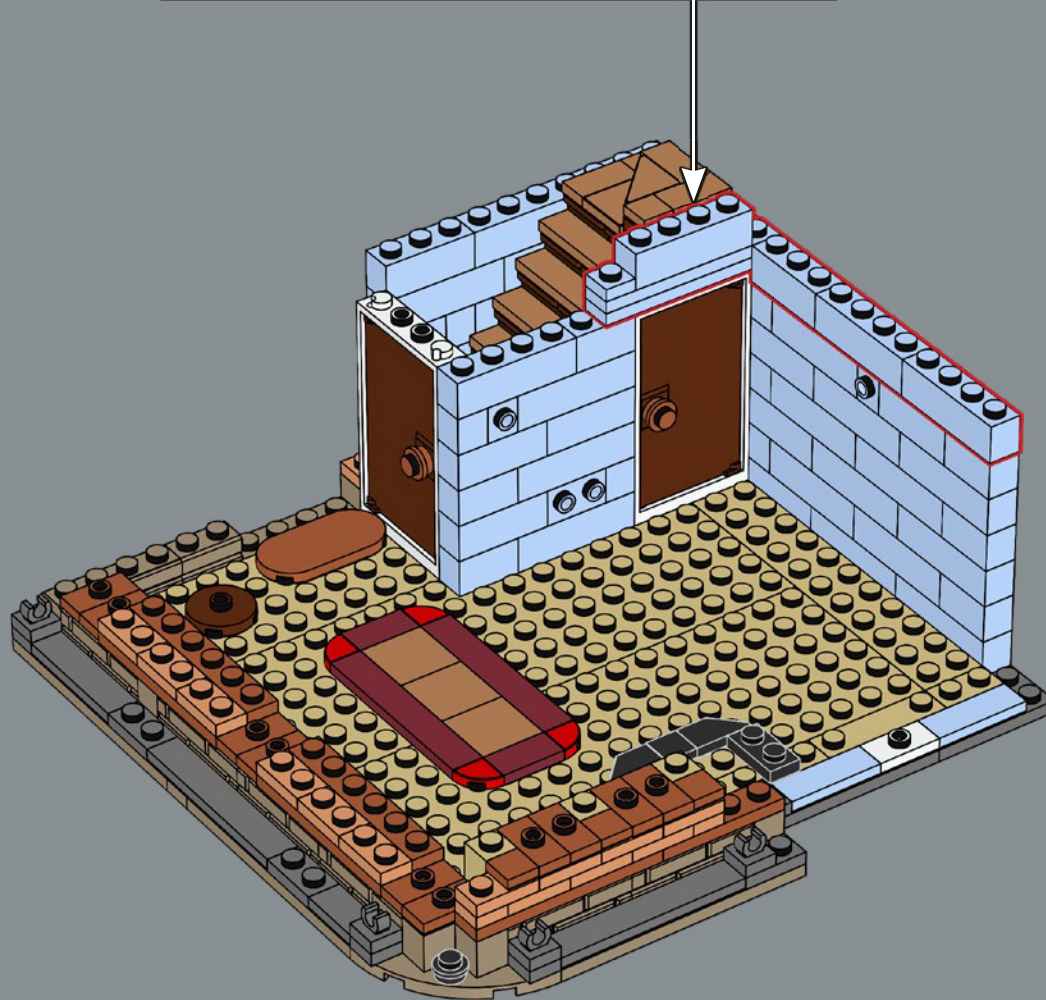
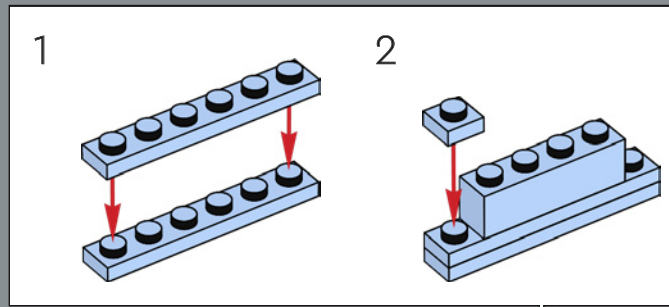

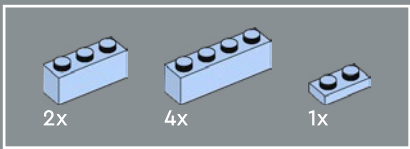

254

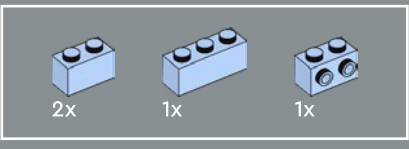
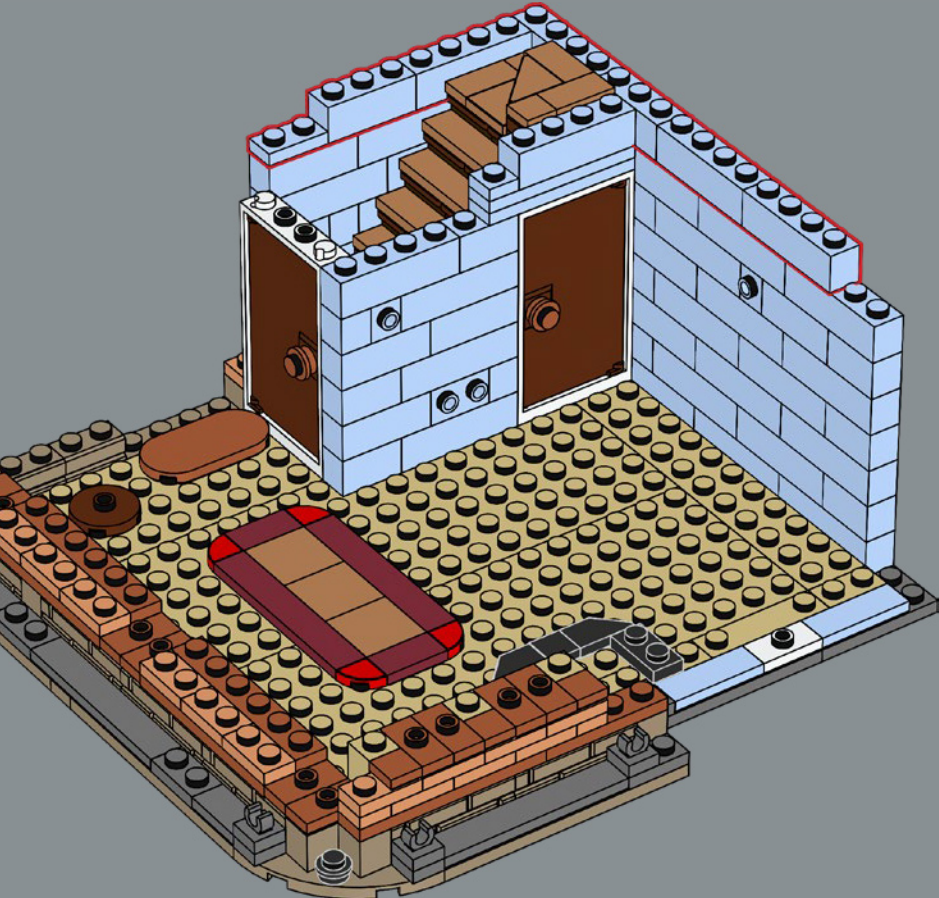

255

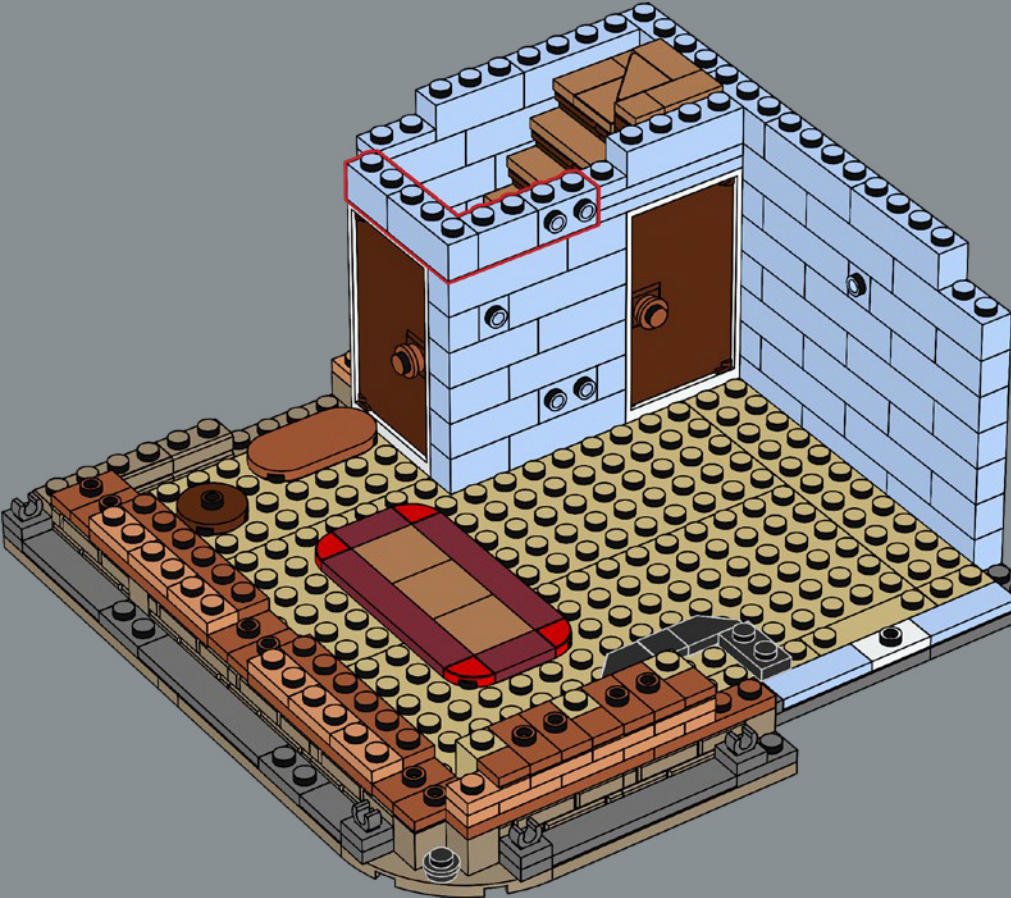

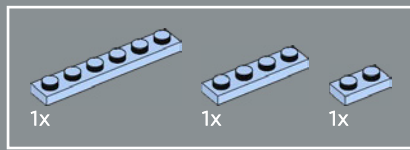

256

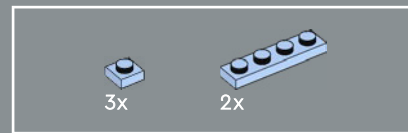
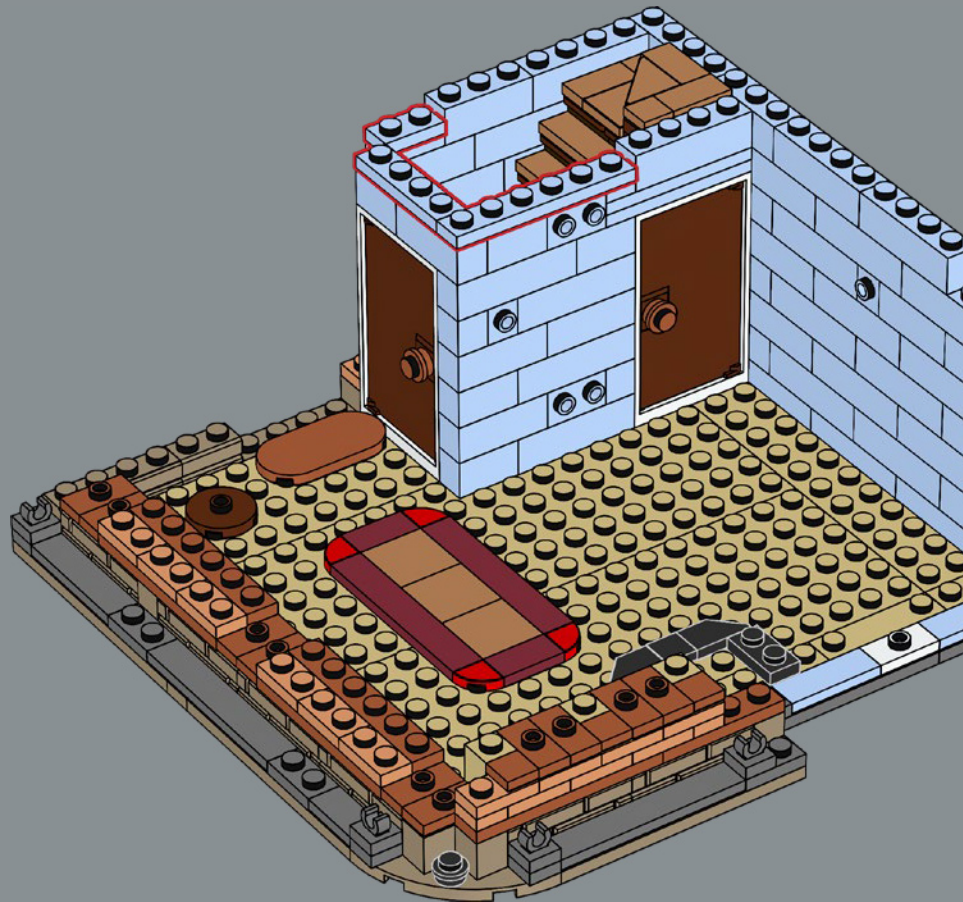

257

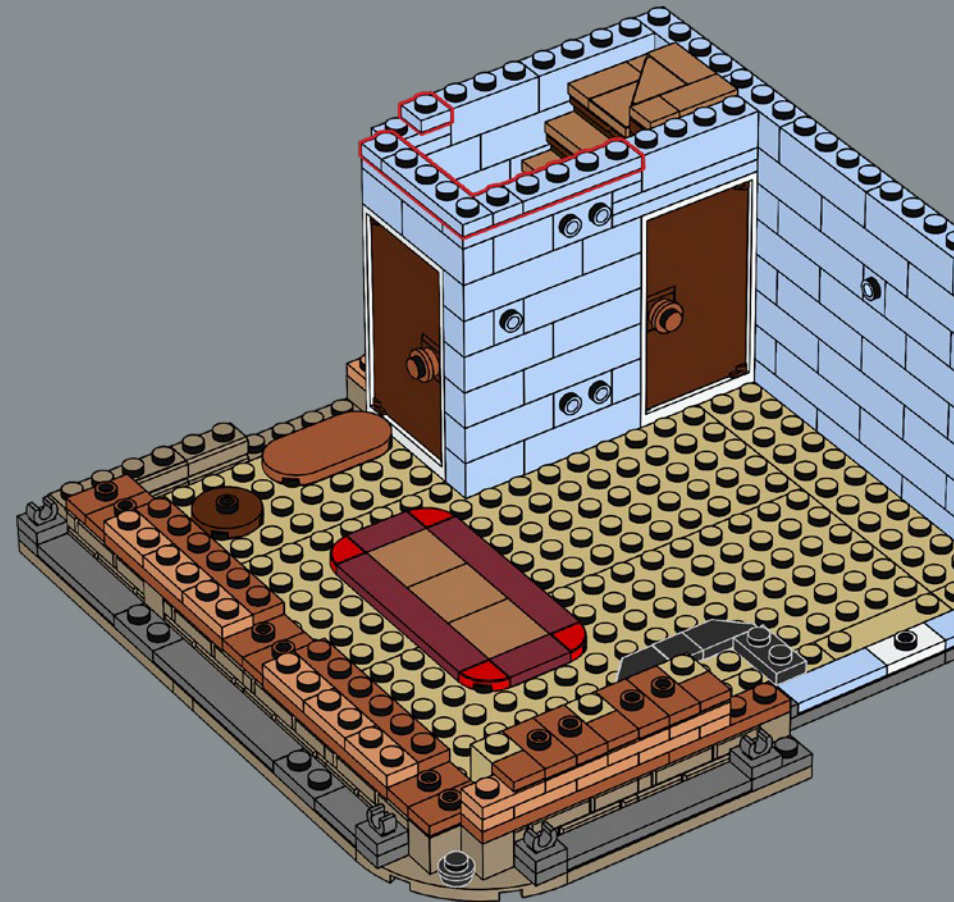

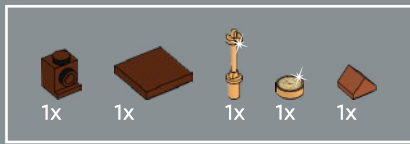

258

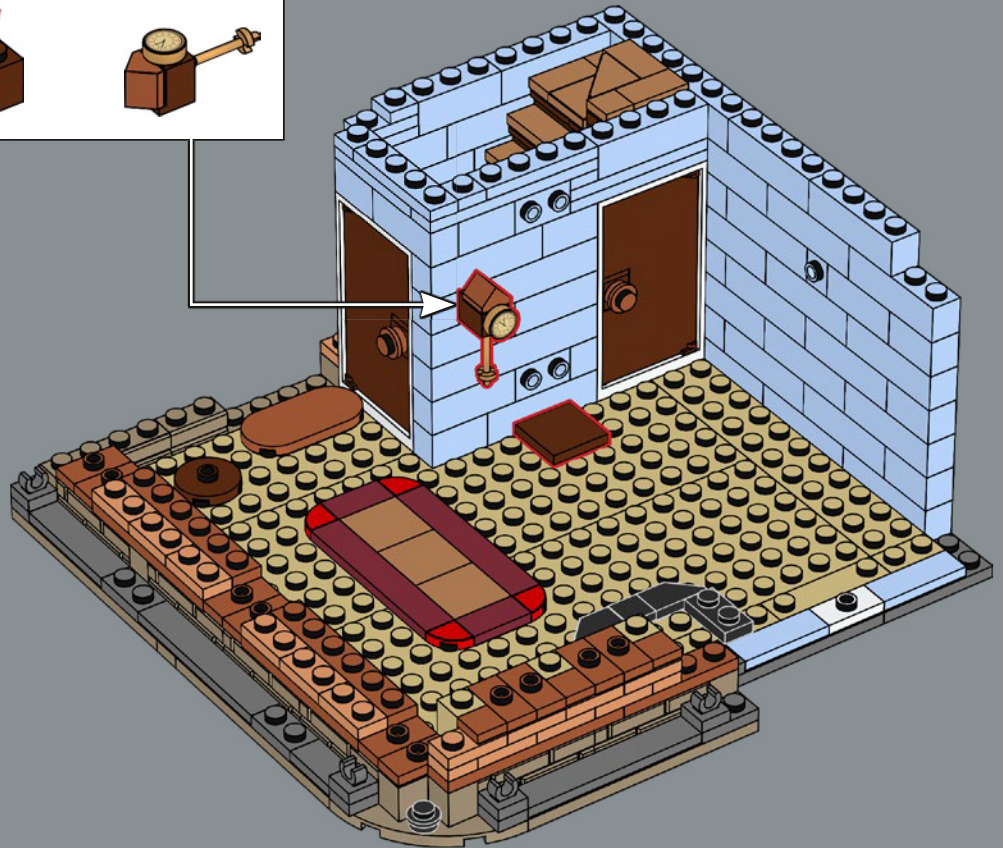
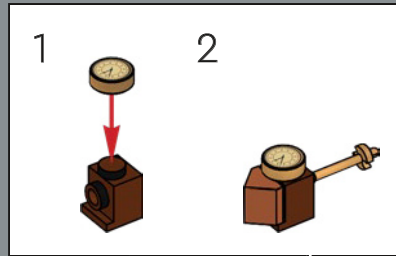

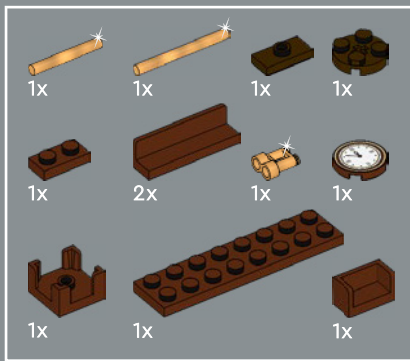

259

1



2



3

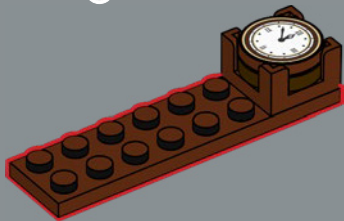

4

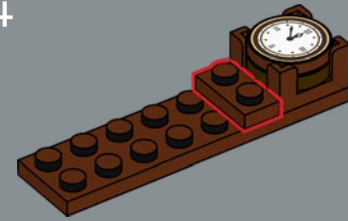

5

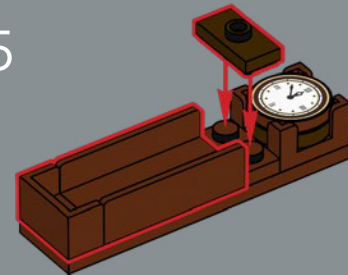

1

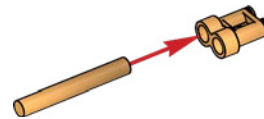

2

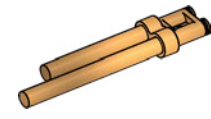

6

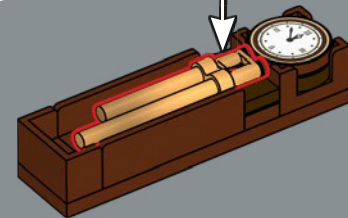

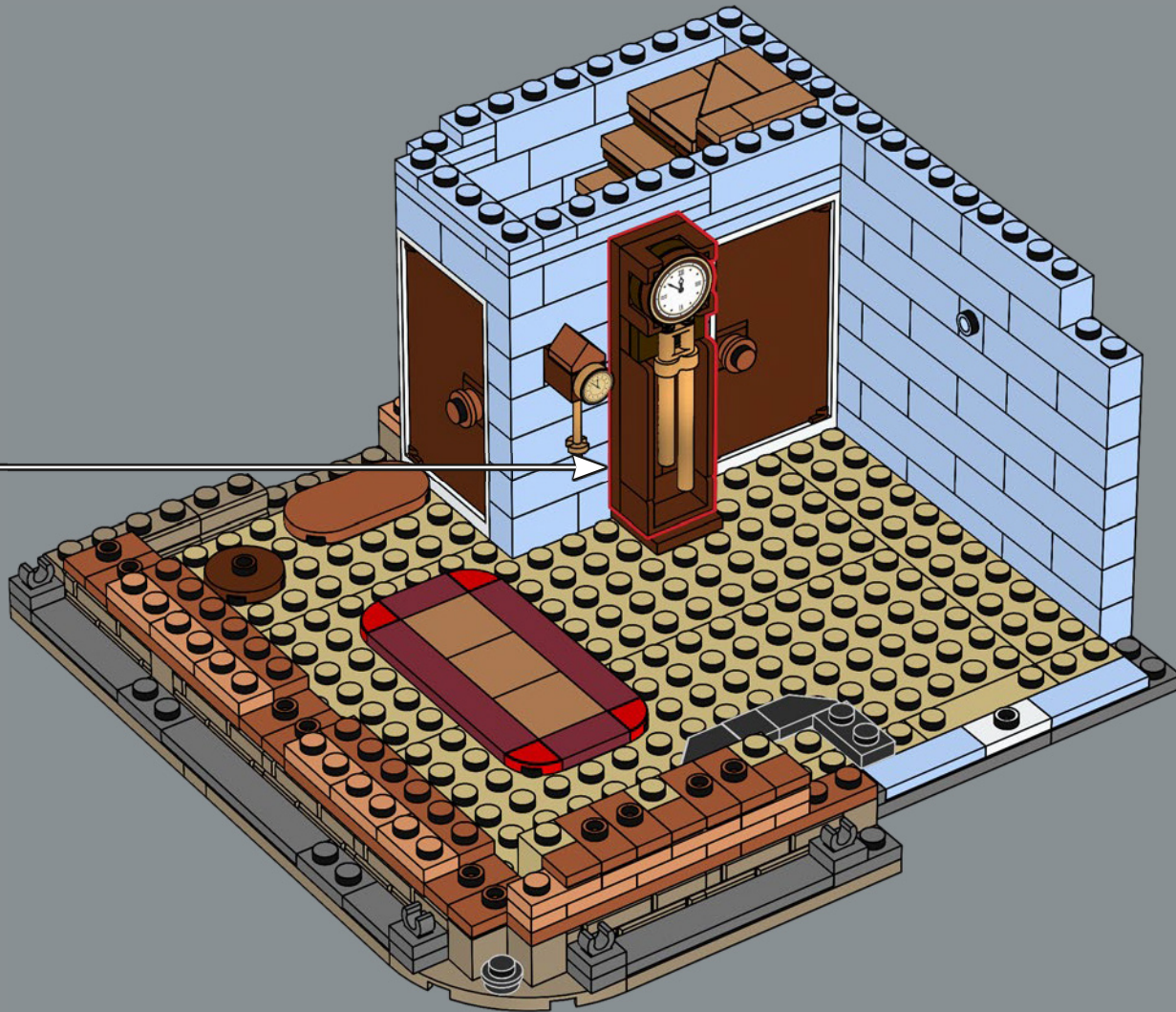



260

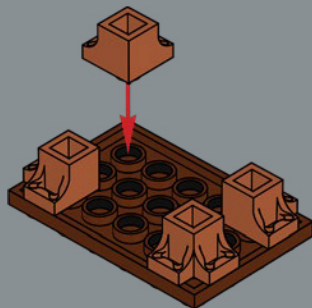

261

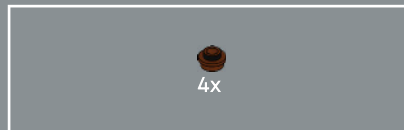
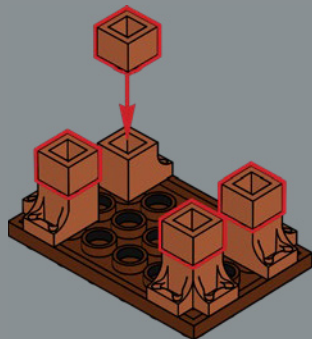

262

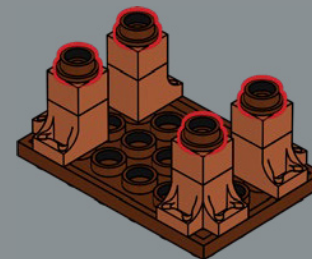

263

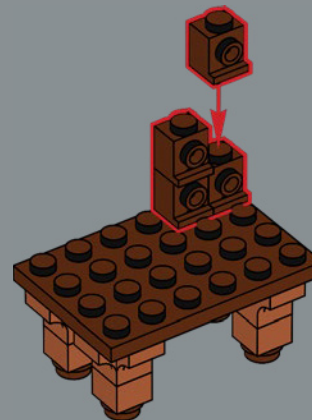

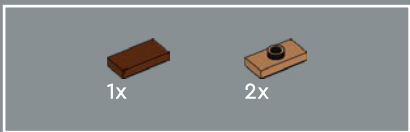

264

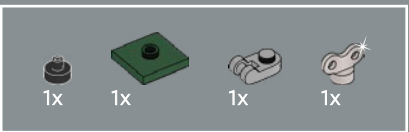
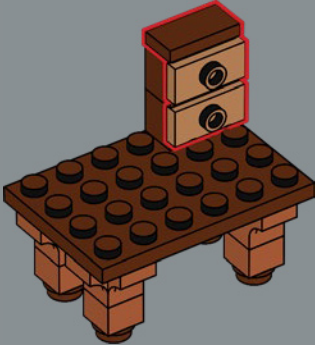

266

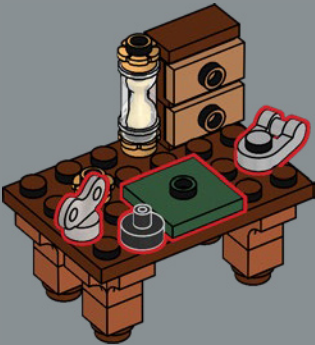

265

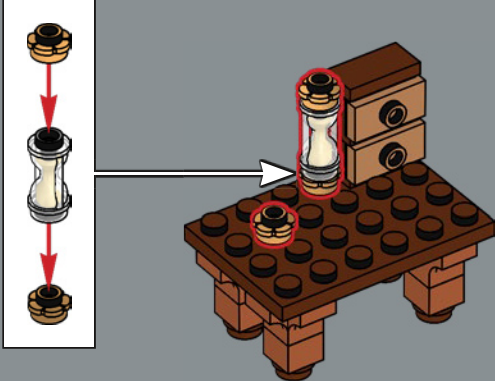

267

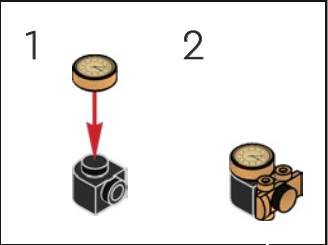





268

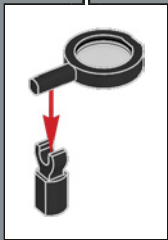
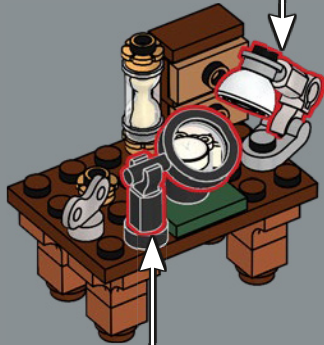
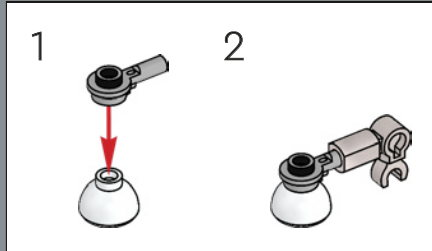

269



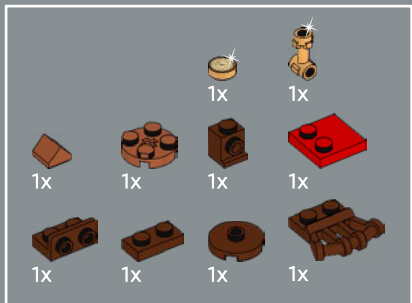

270

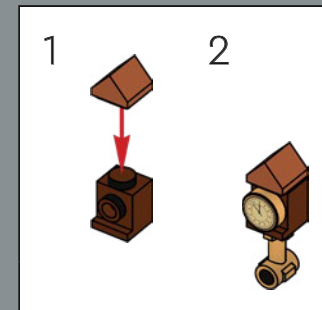
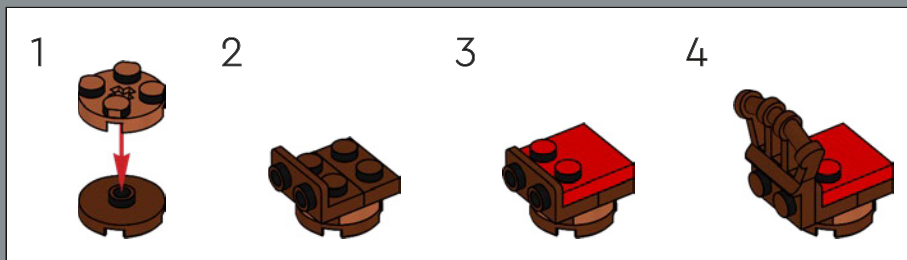

The clockmaker is a passionate craftsman appreciated by locals. His greatest pride is having designed the large clock of the LEGO® Creator Expert Town Hall (10224). He has fond memories of the mayor's long speech at the inauguration.



L'horloger est un artisan passionné apprécié des habitants. Sa plus grande fierté est d'avoir conçu la grande horloge de la mairie LEGO® Creator Expert (10224). Il garde de bons souvenirs du long discours du maire lors de l'inauguration.

El relojero es un artesano apasionado muy querido por los vecinos. Su mayor orgullo es haber diseñado el gran reloj del Ayuntamiento LEGO® Creator Expert (10224). Todavía recuerda el largo discurso del alcalde durante la inauguración.

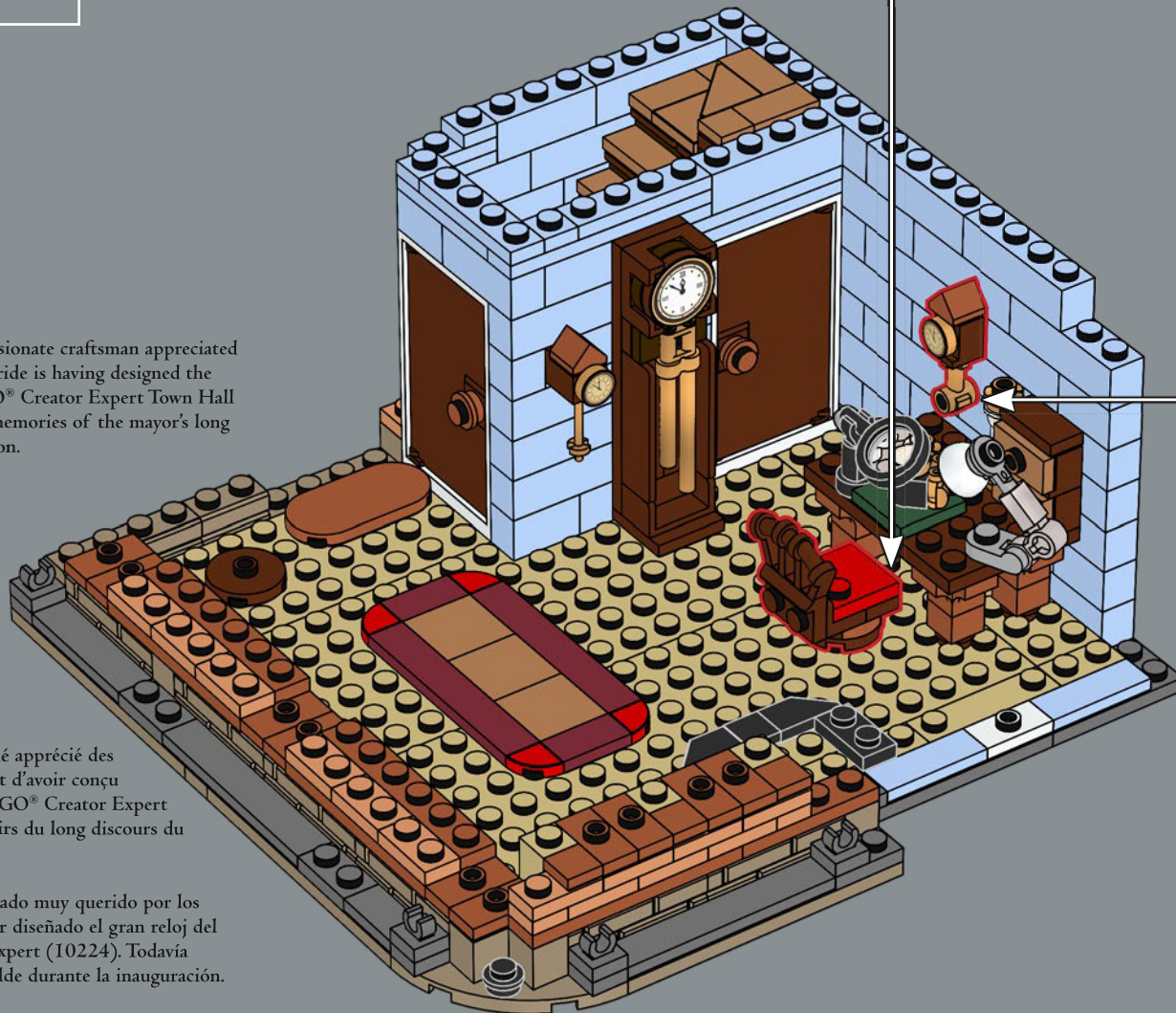

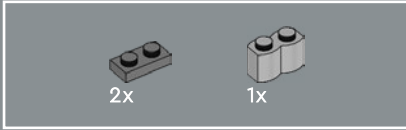
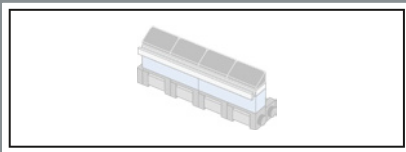

271

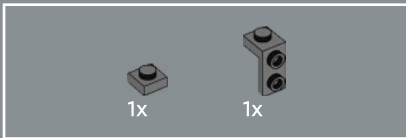
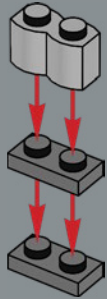

272

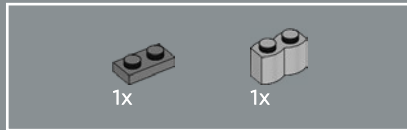

273

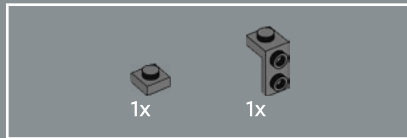
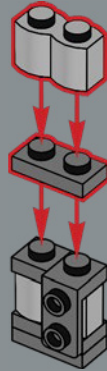

274

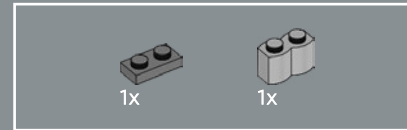
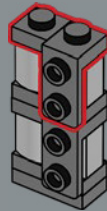

275

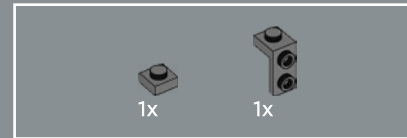
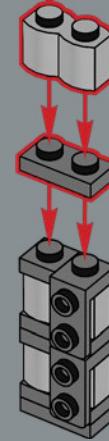

276

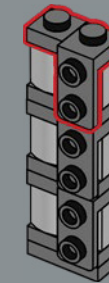

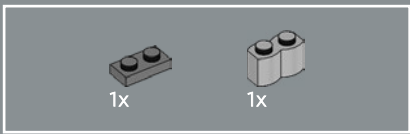

277

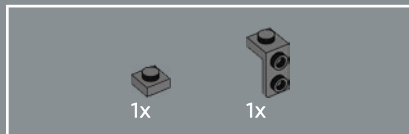
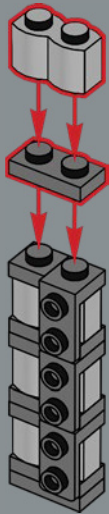

278

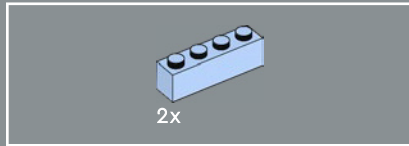
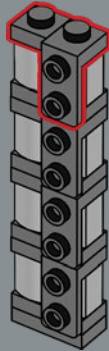

279

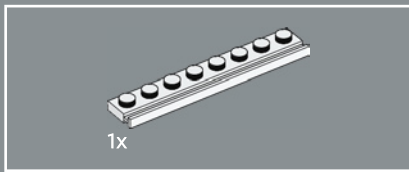
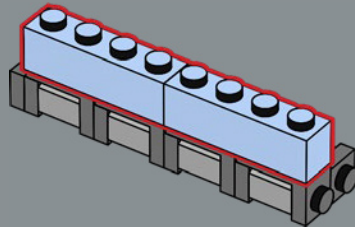

280

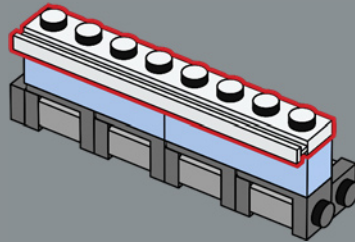

281

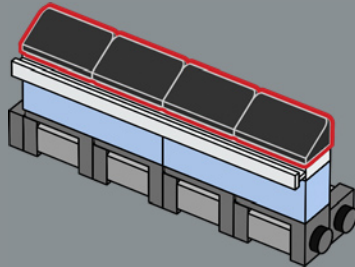

282



283

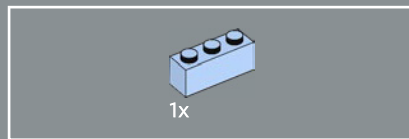

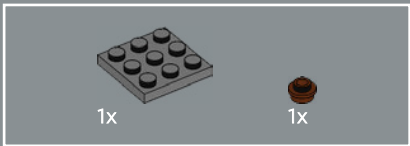

284

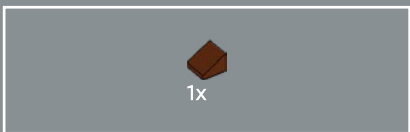
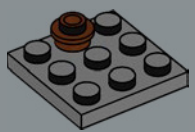

285

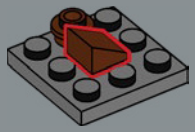

286

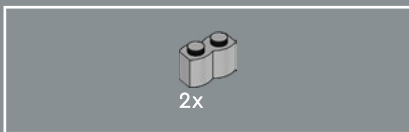
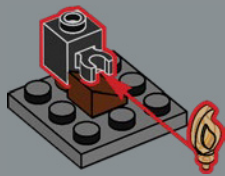

287

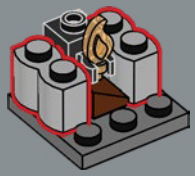

288

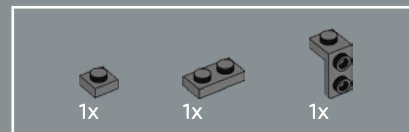
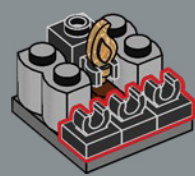

289

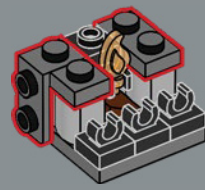

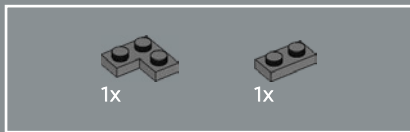

290

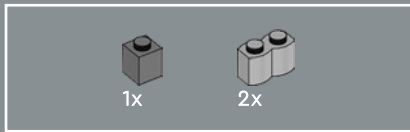
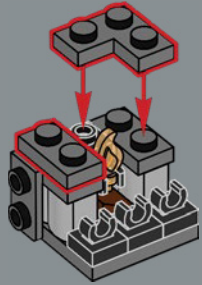

291

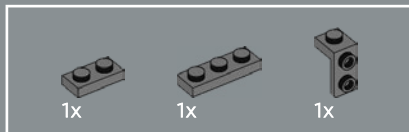
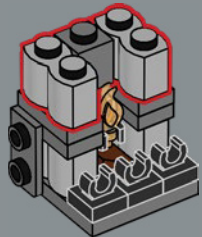

292

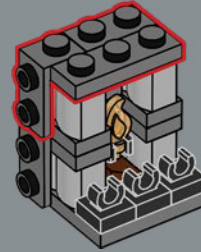

293



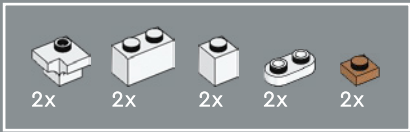

294

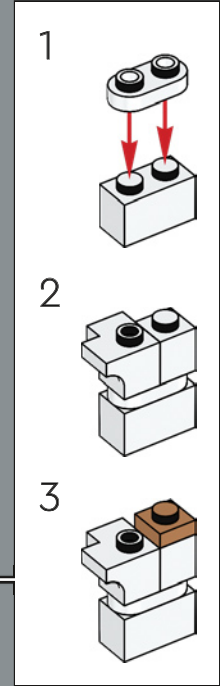
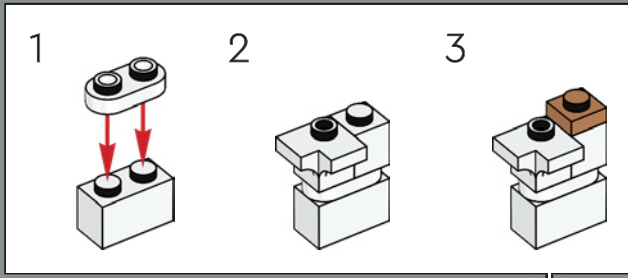



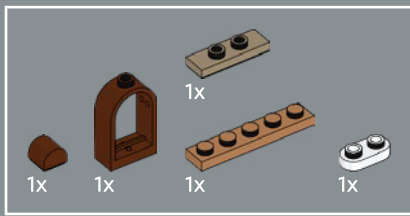

295

1

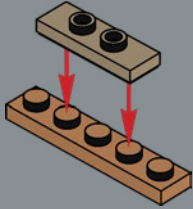

2

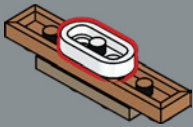

3

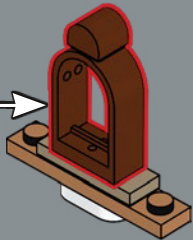
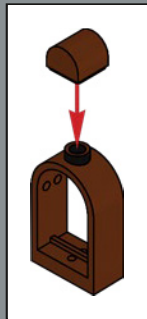

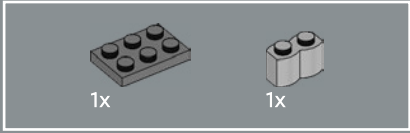
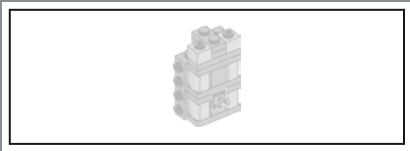

296

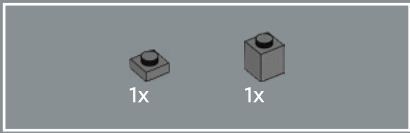
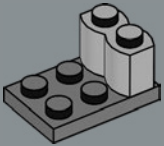

297

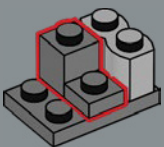

298

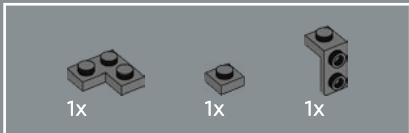
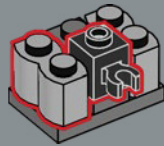

299

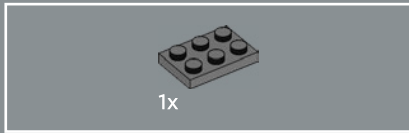
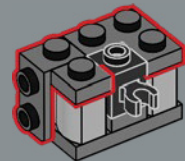

300

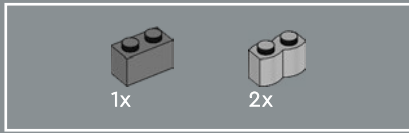
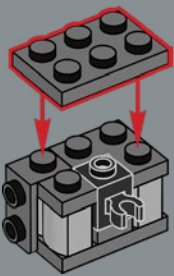

301

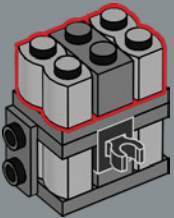

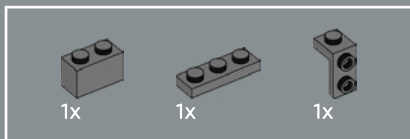

302

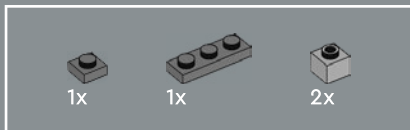
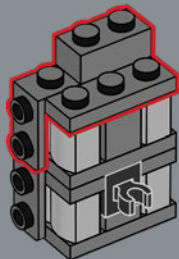

303

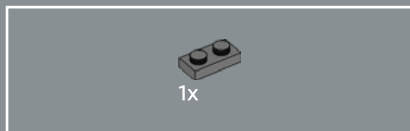
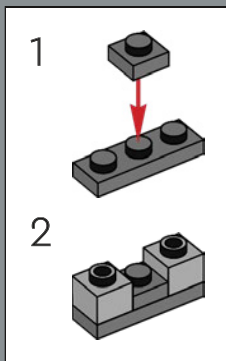

304

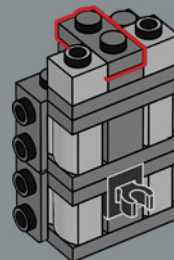

305





306

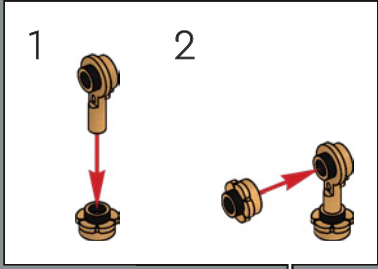

307



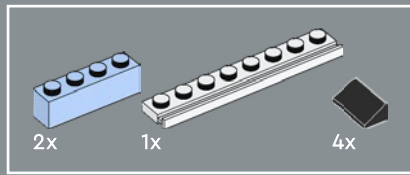

308

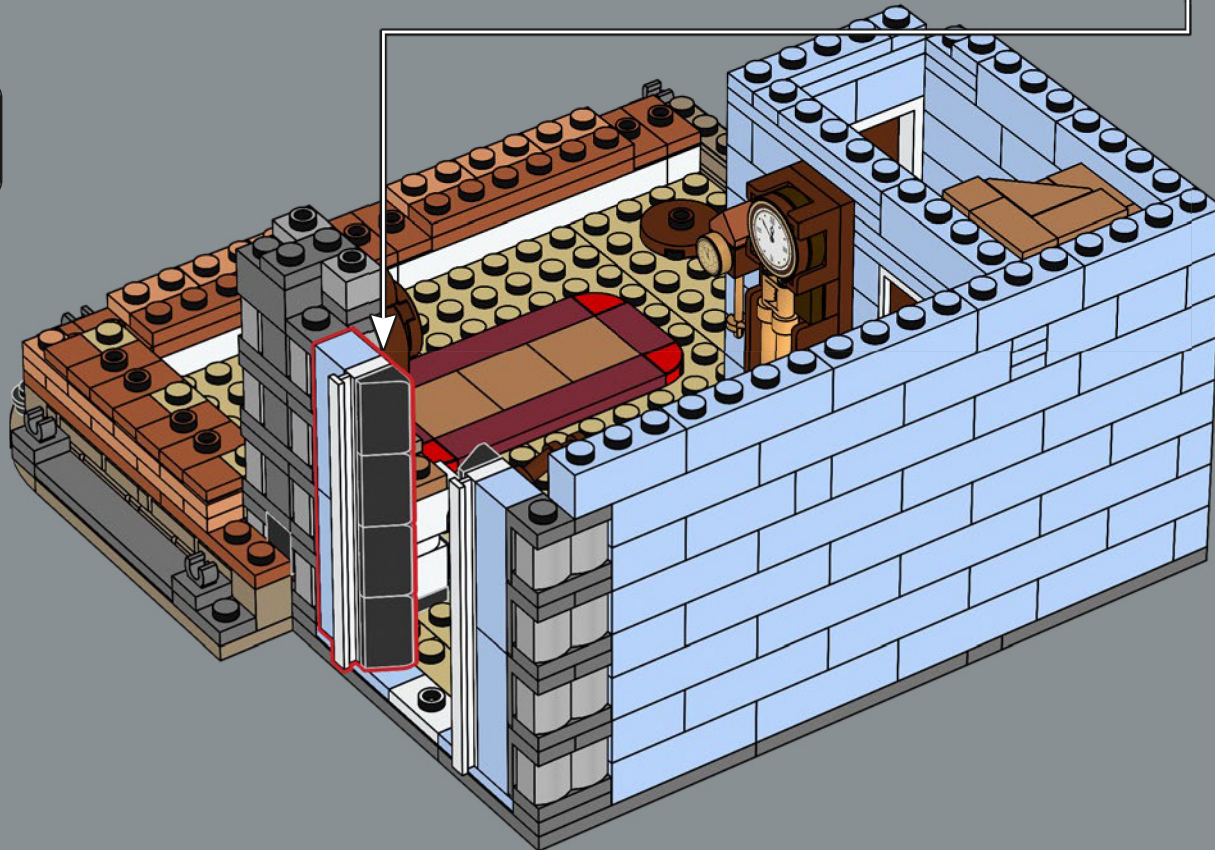
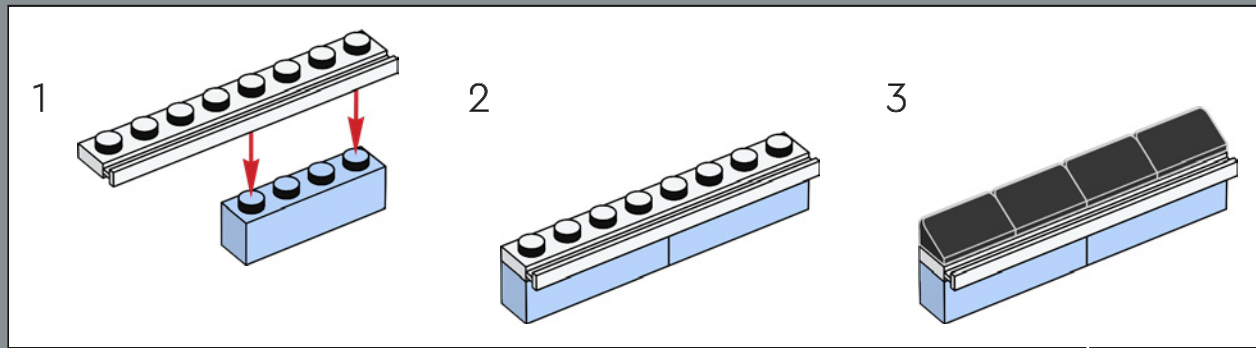

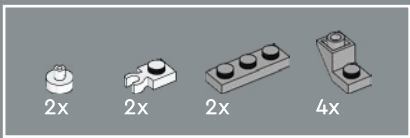

# 309

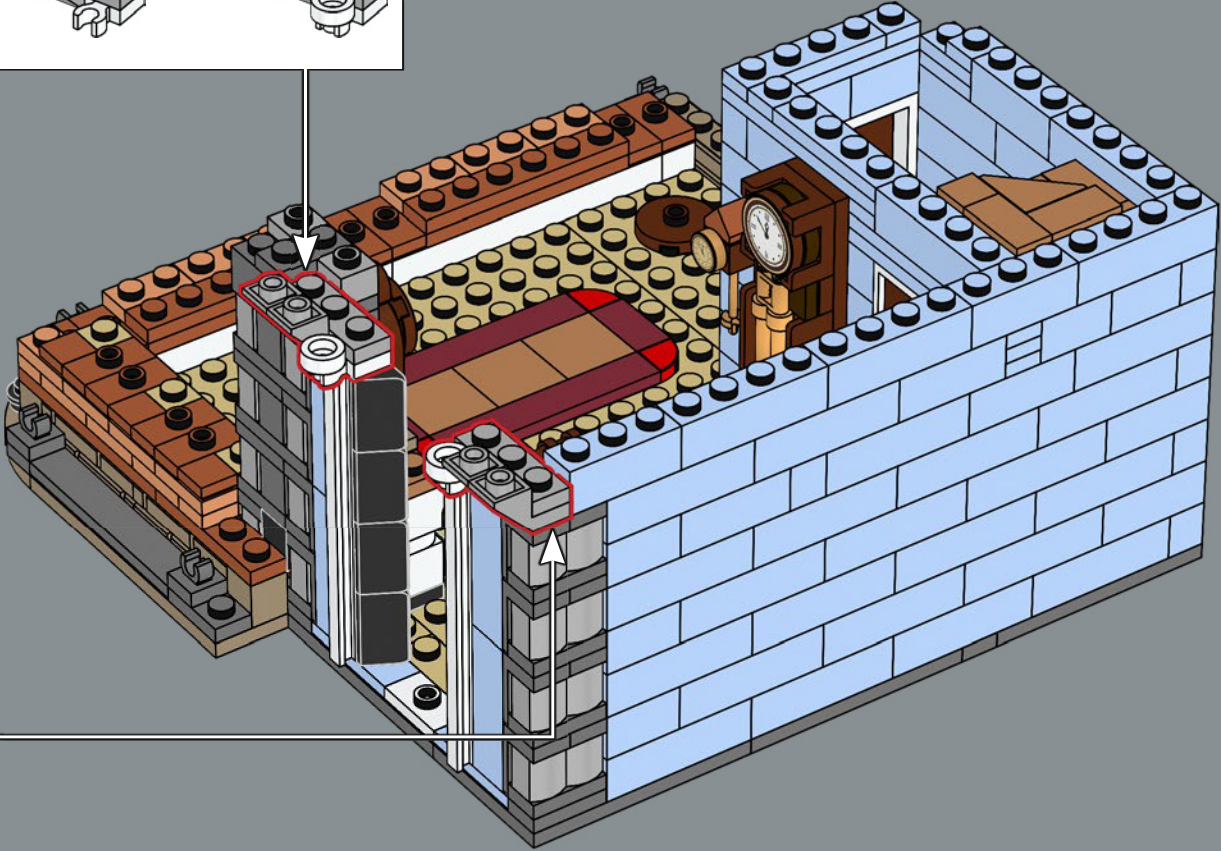
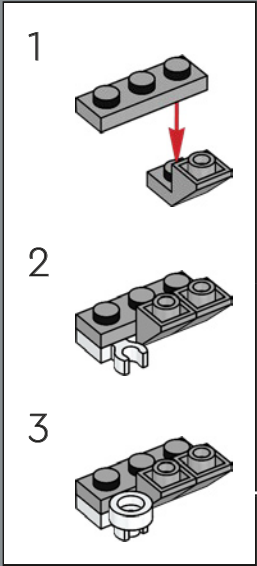
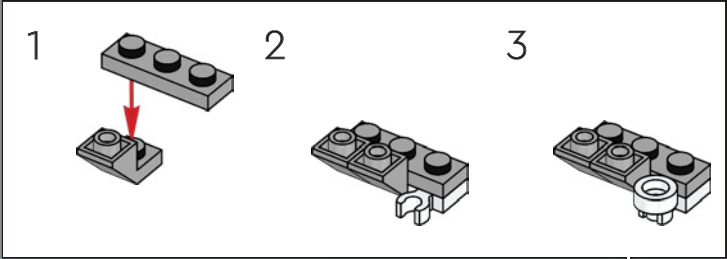

310

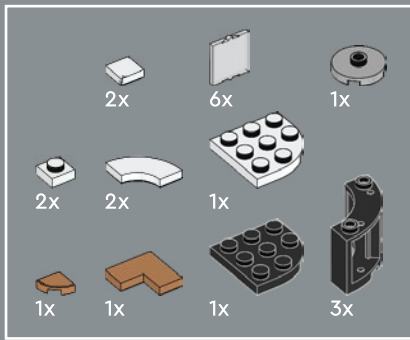

1



2



3

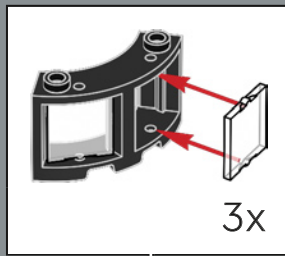
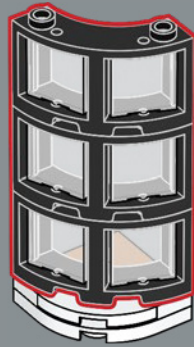

1

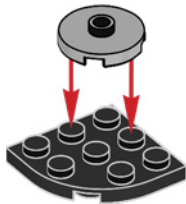

2

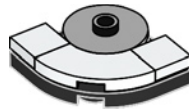

4

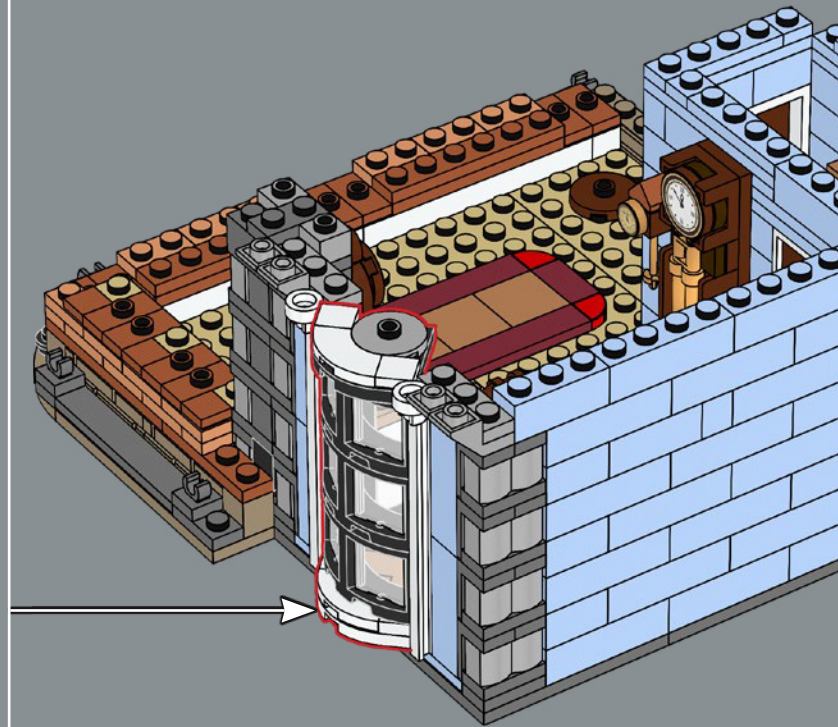
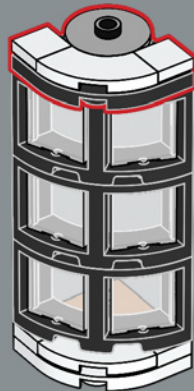

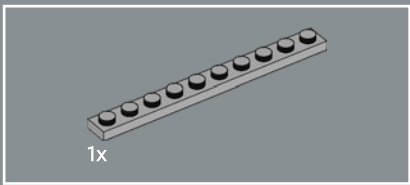

311

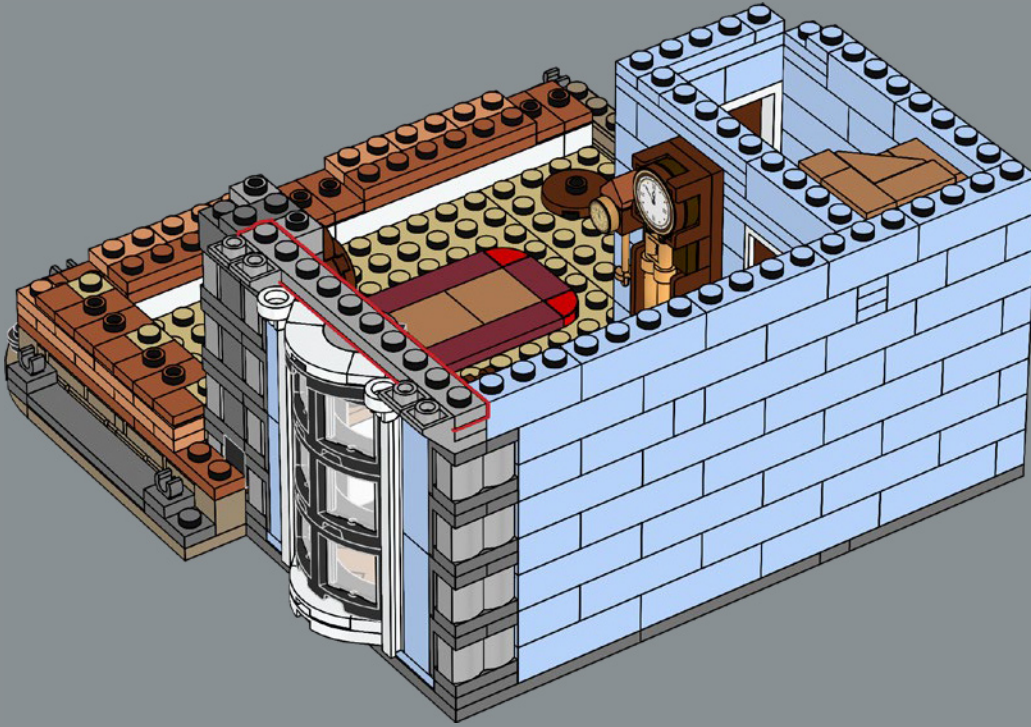



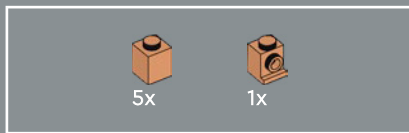

312

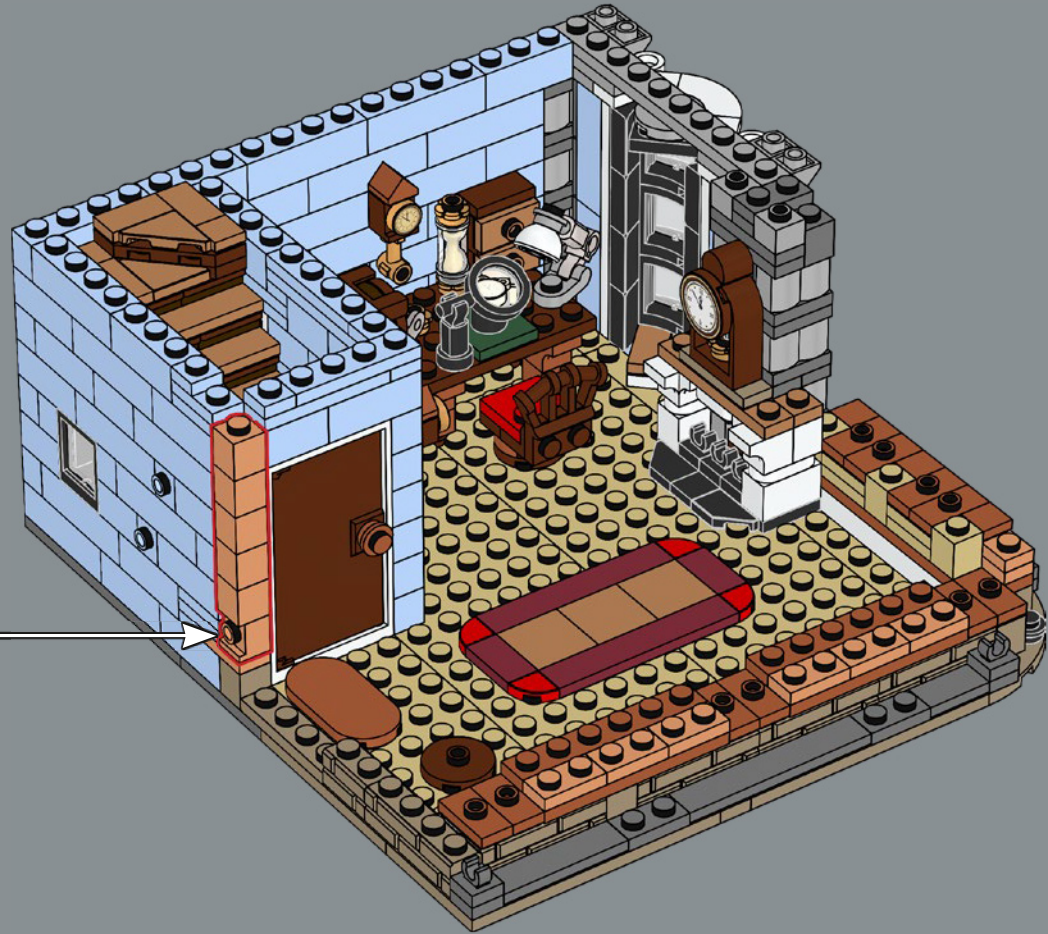
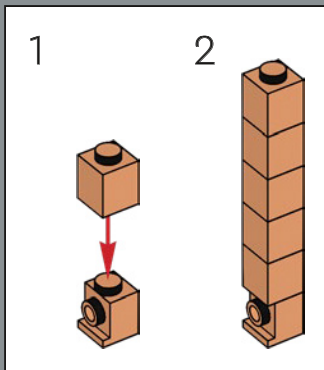

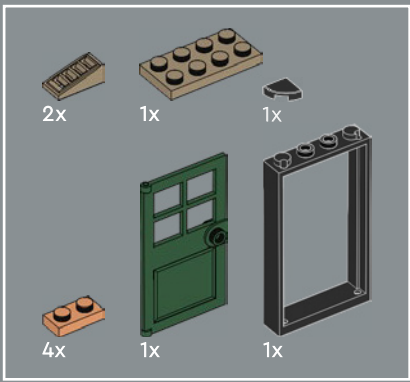

313

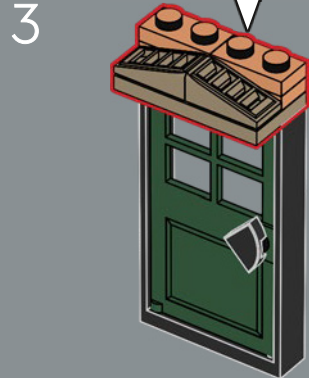
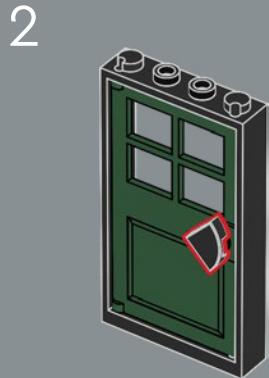
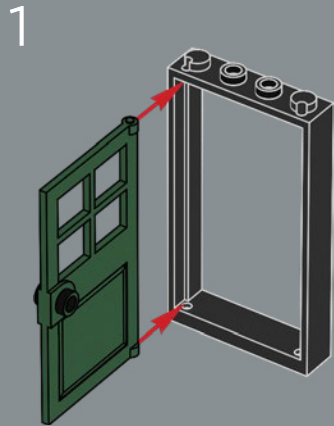
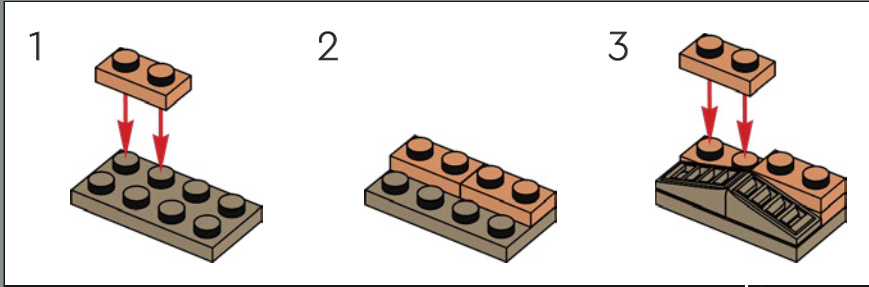

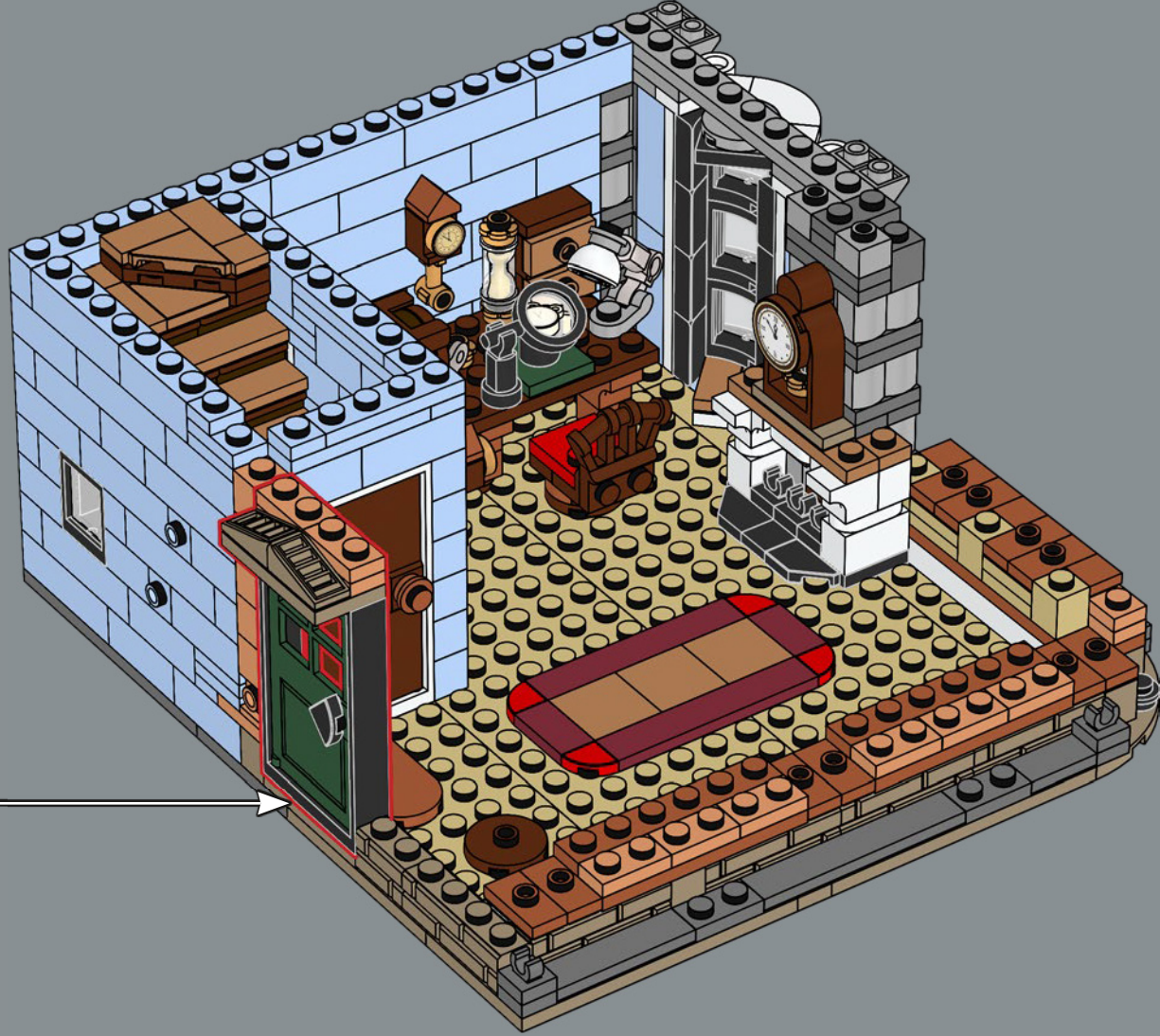

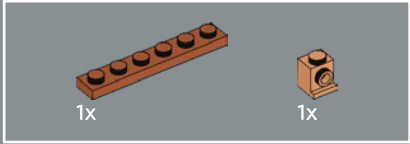
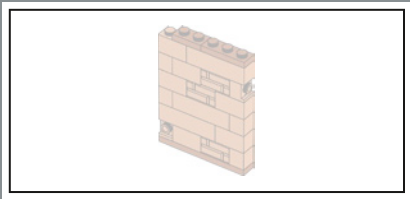

314

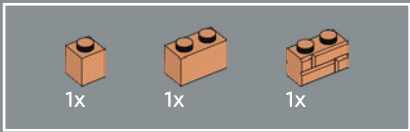
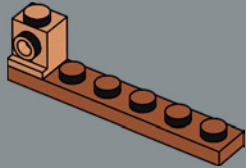

315

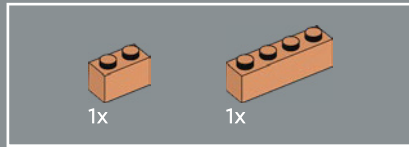
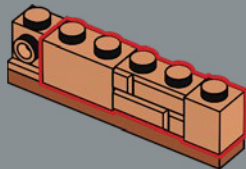

316

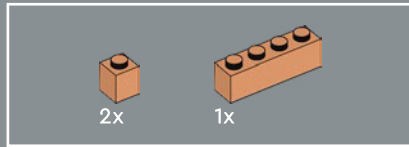
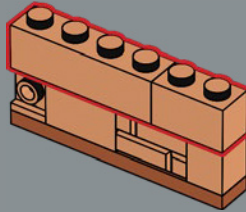

317

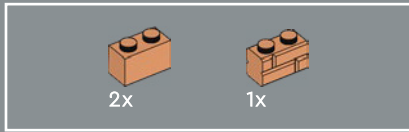
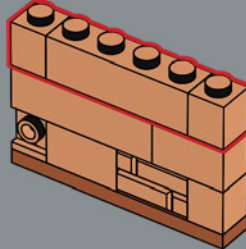

318

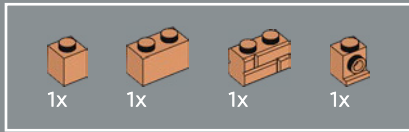
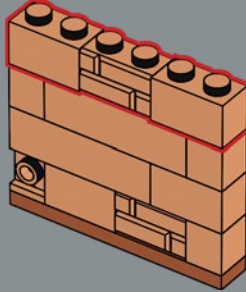

319

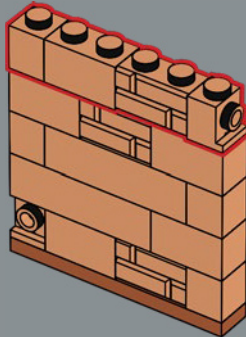

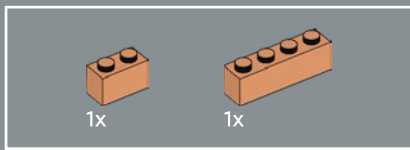

320

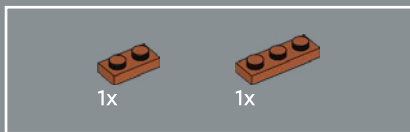
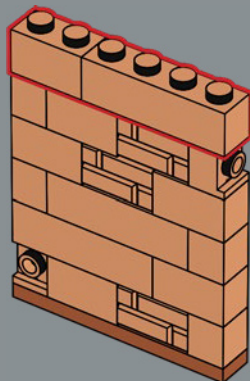

321

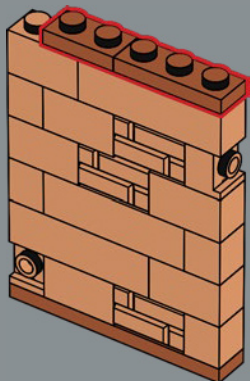

322

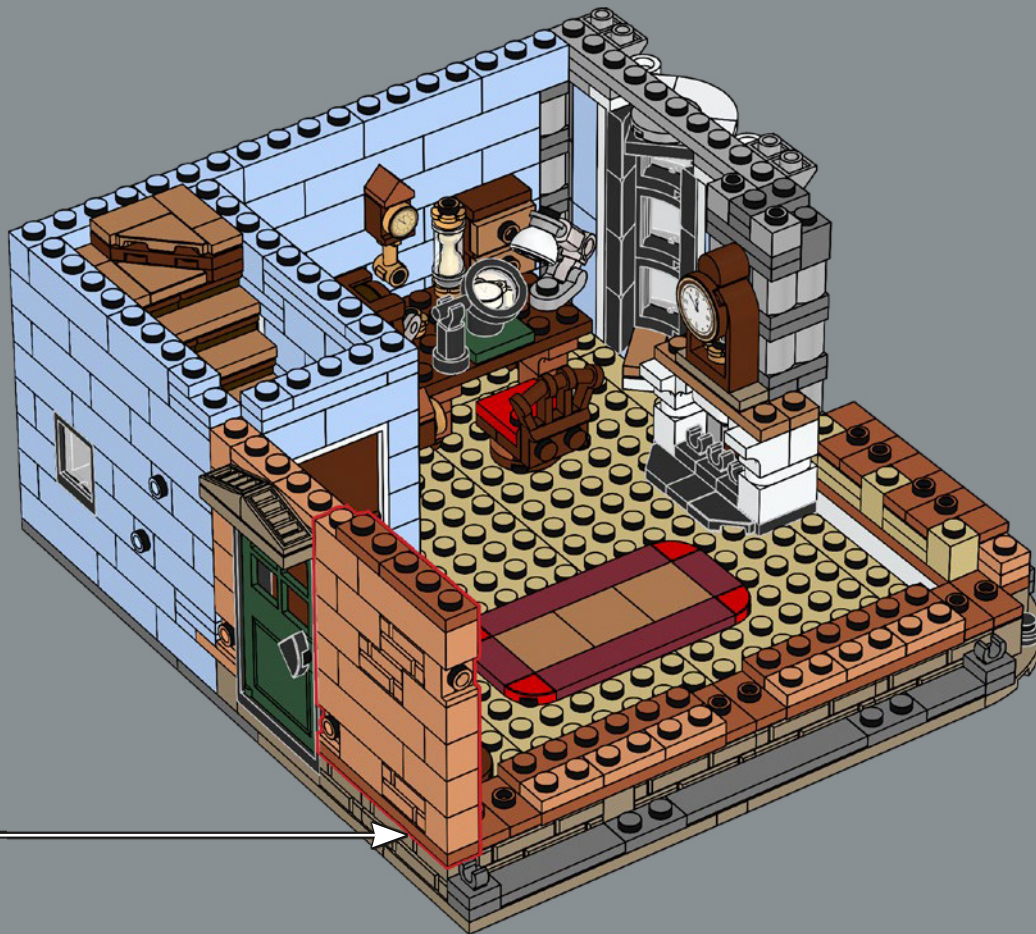

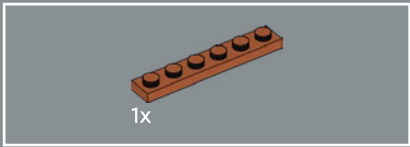

1x

323

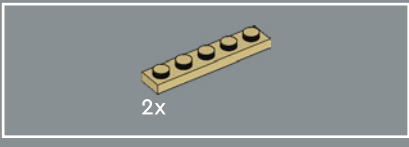
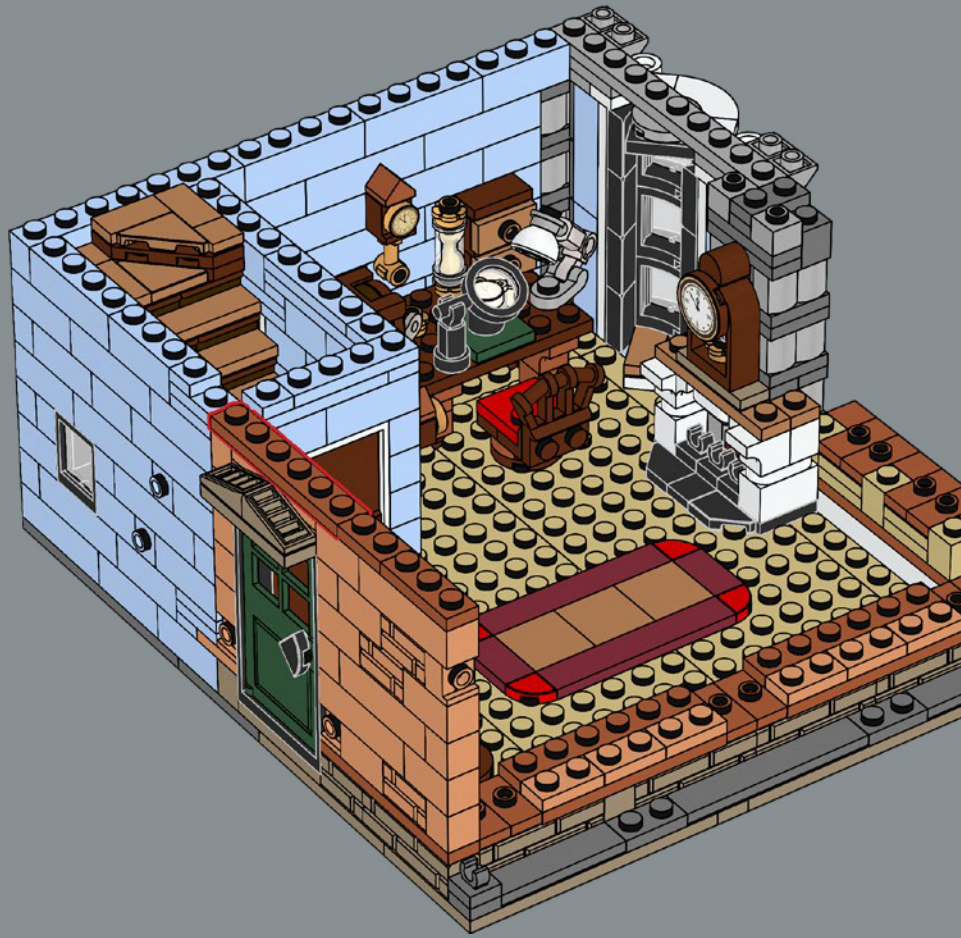

2x

324

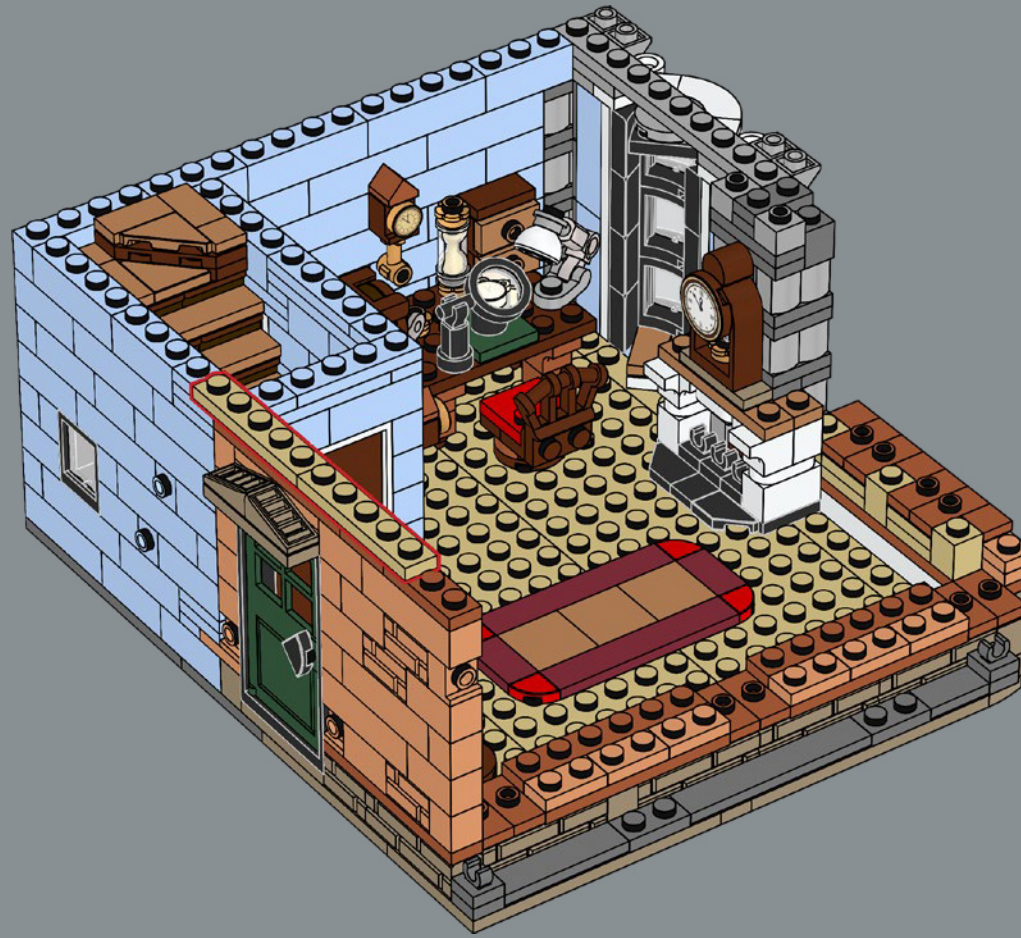

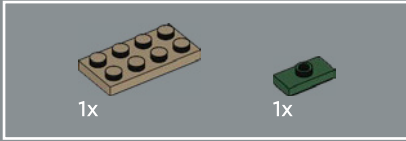

325

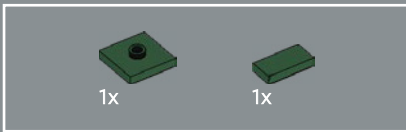
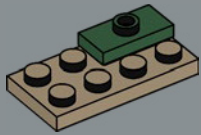

326

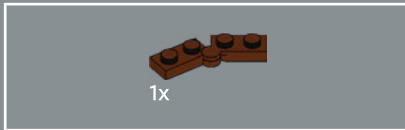
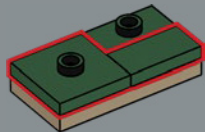

327

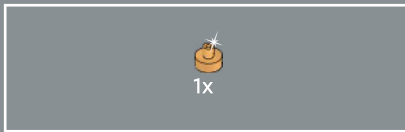
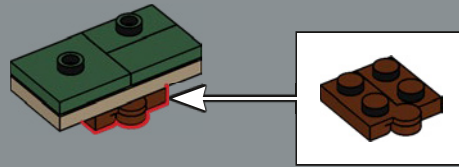

328

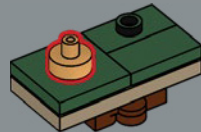

329

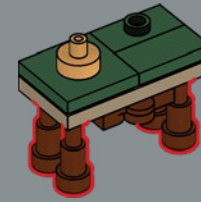

330

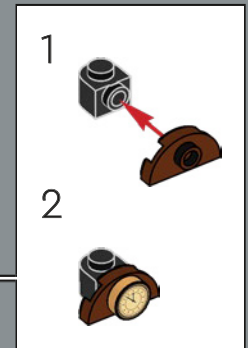
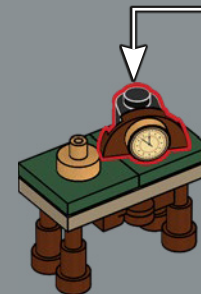

1x

1x

331

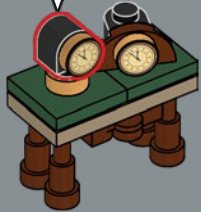
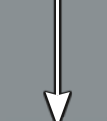
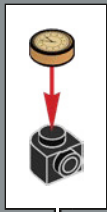

332





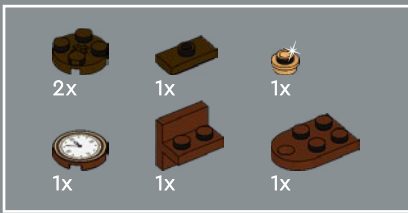

333

1

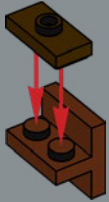

2

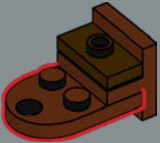

3

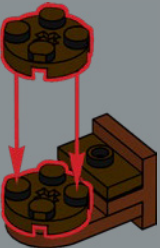

4





334

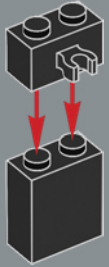

335

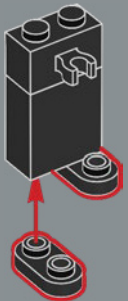

336



337



338



339



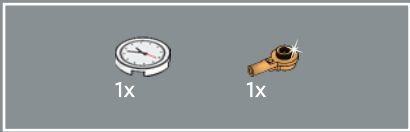

340



341

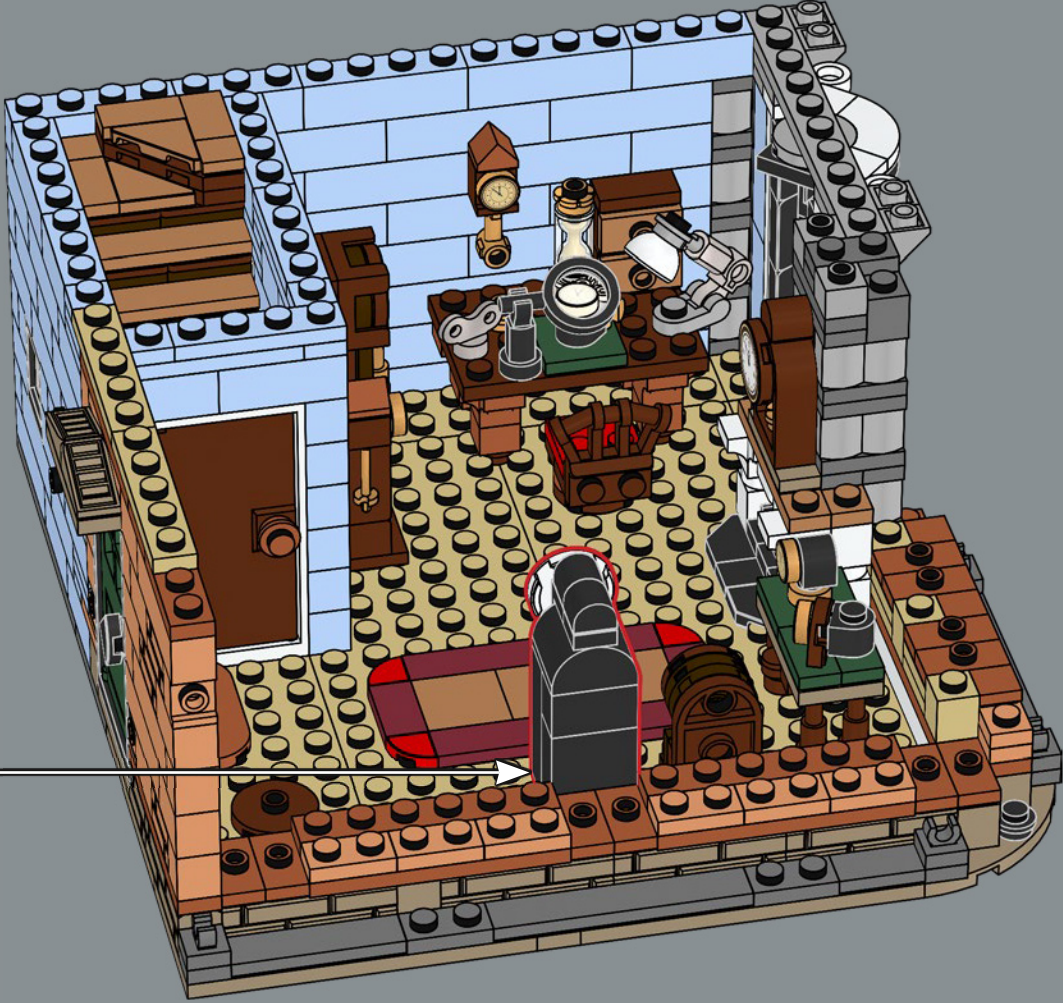



342

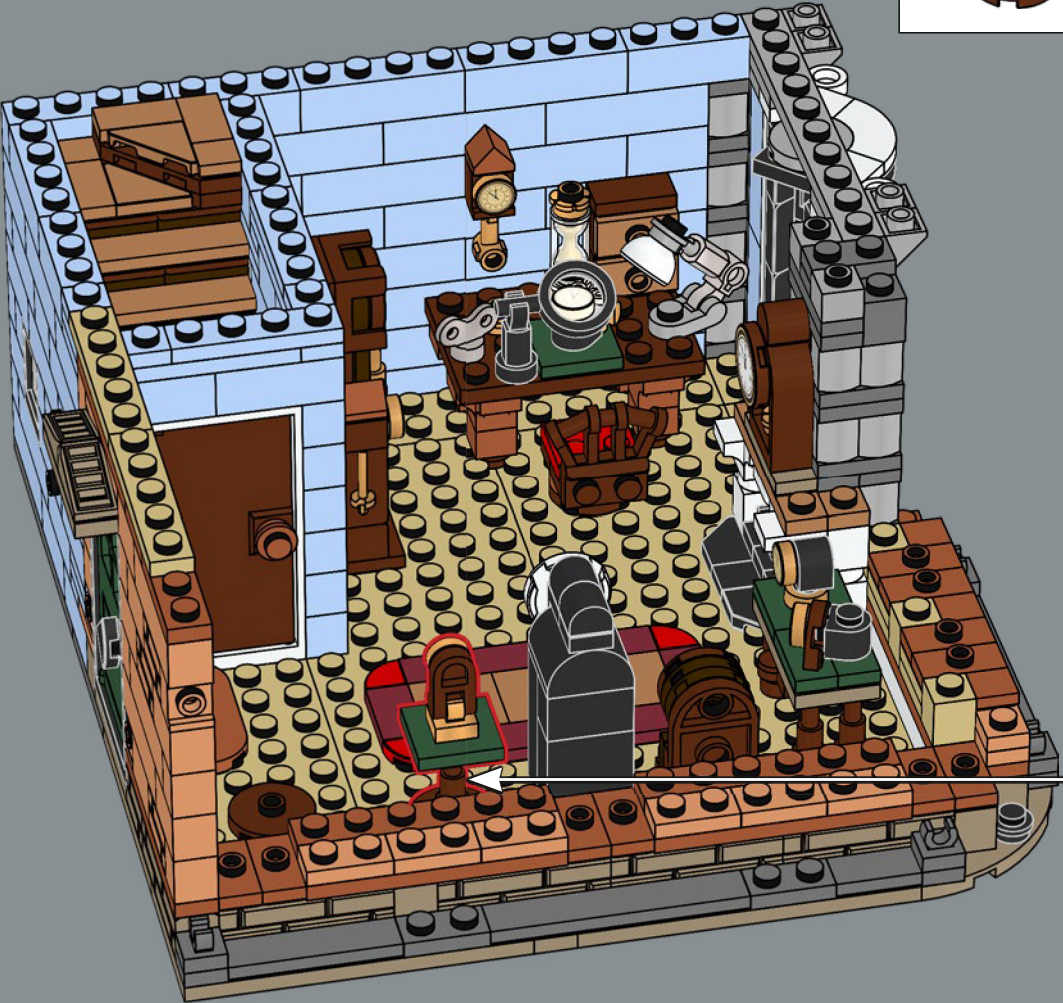
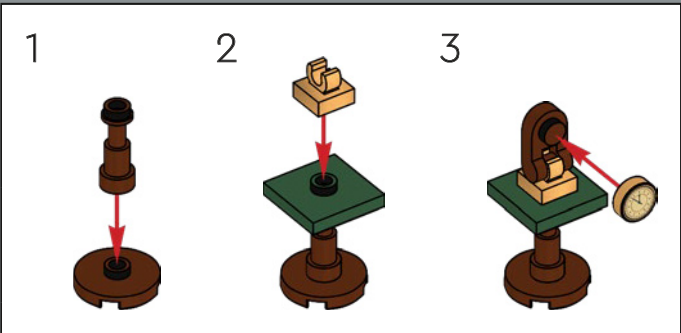

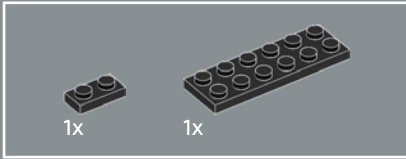
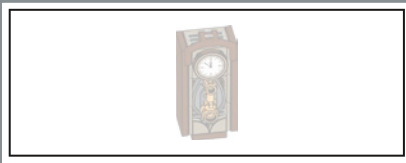

343

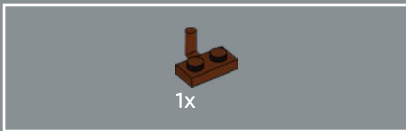
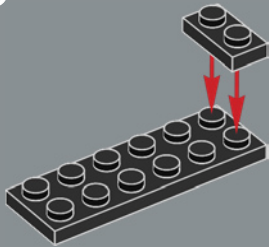

344

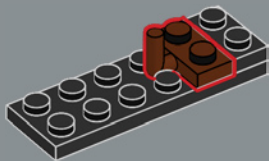

345

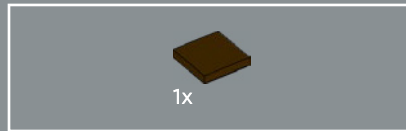
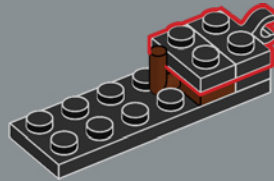

346

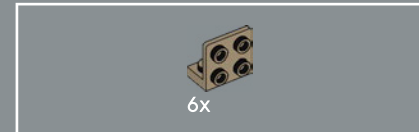
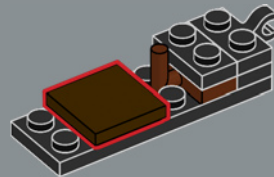

347

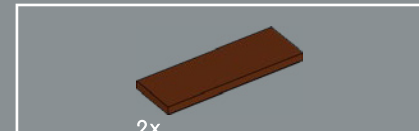
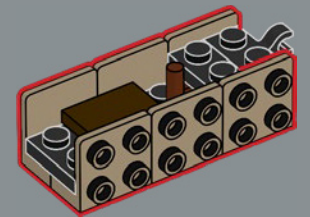

348

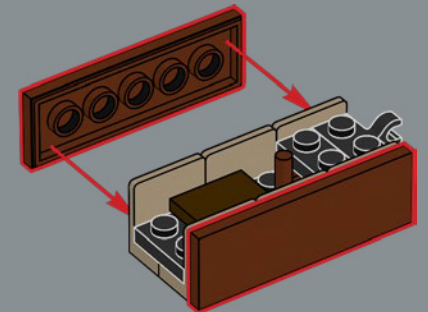

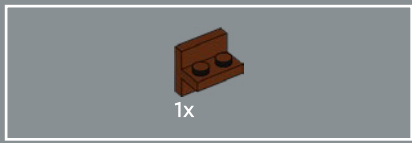

349

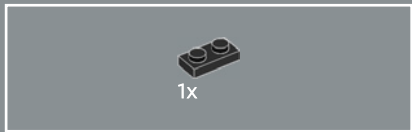
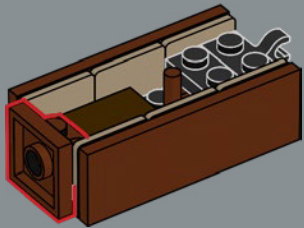

350

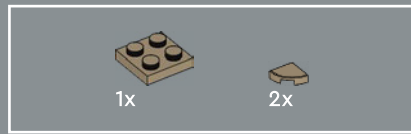
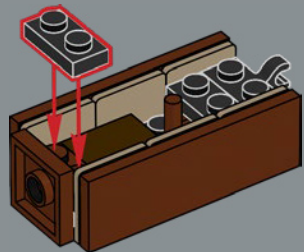

351

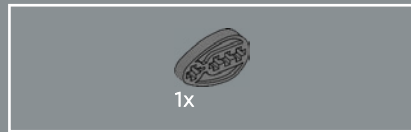
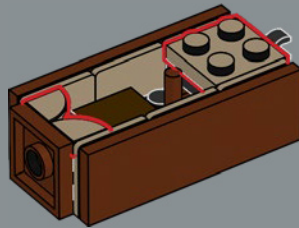

352

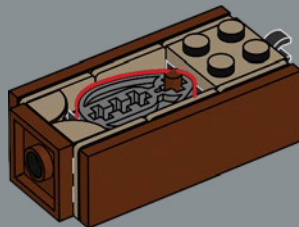

353

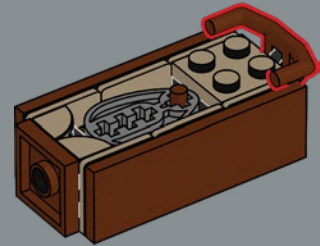

354

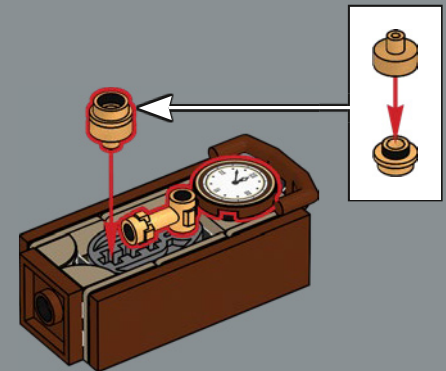

355



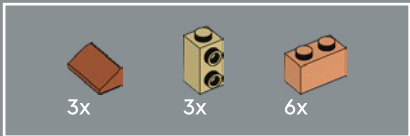

356

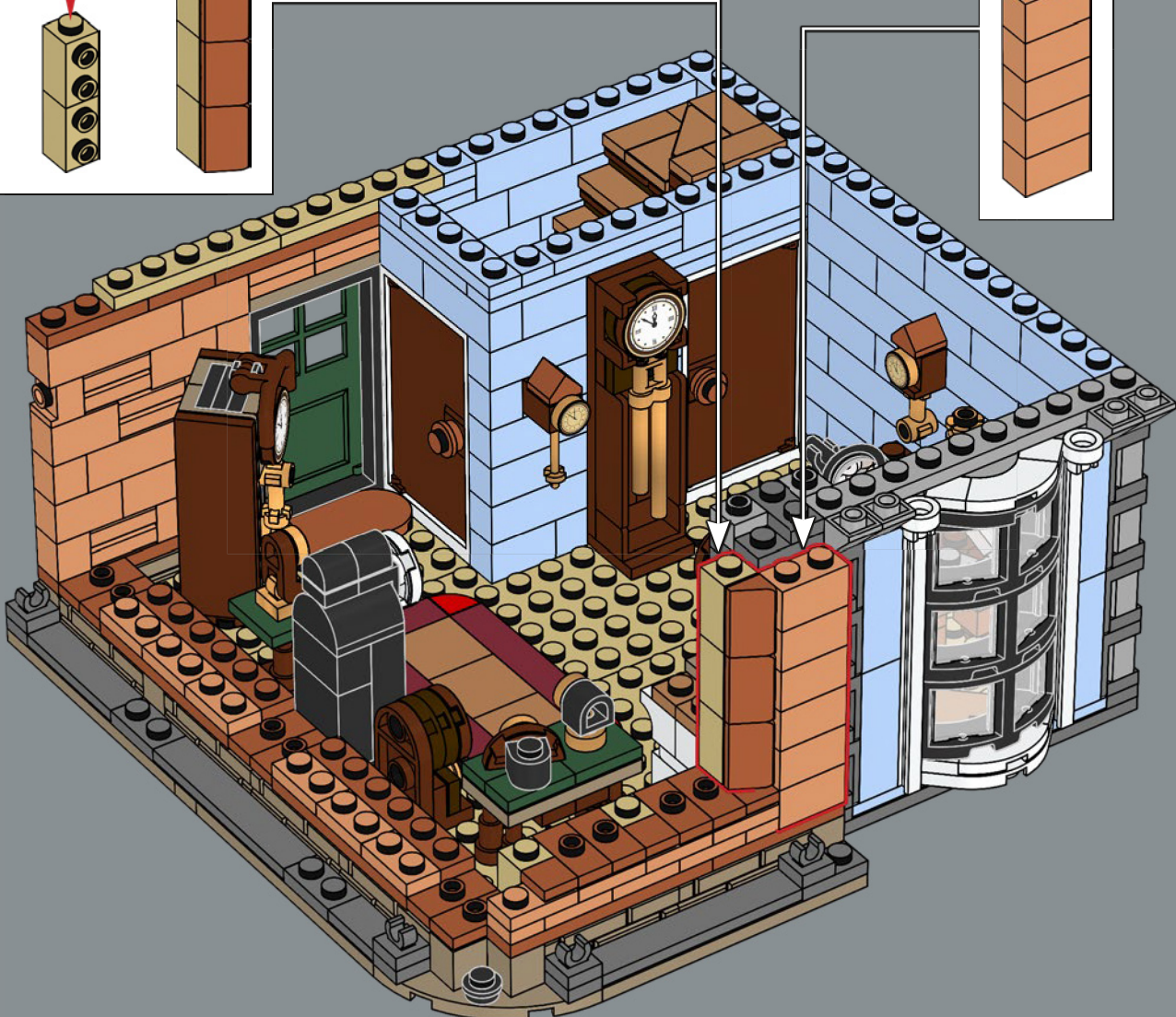
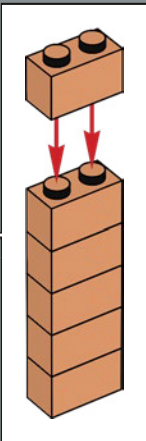
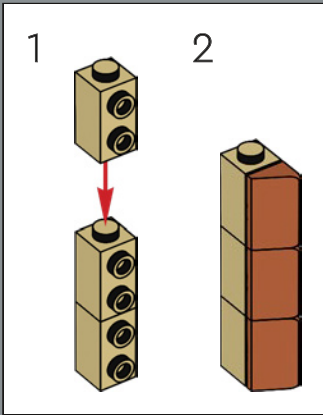



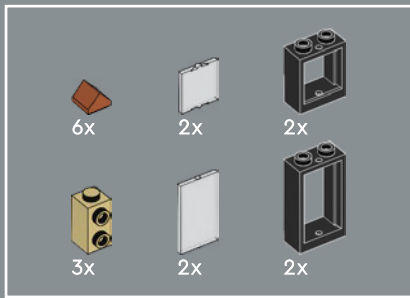



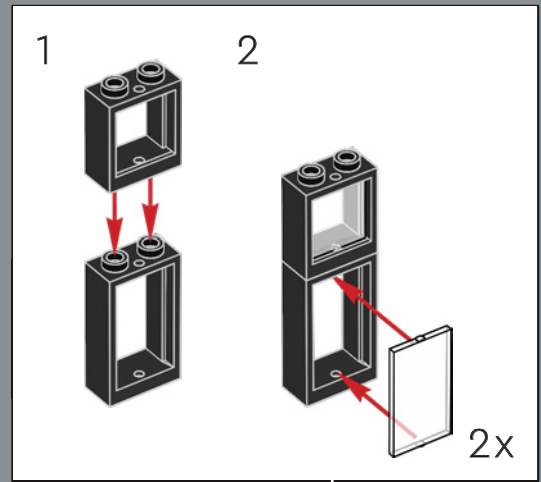
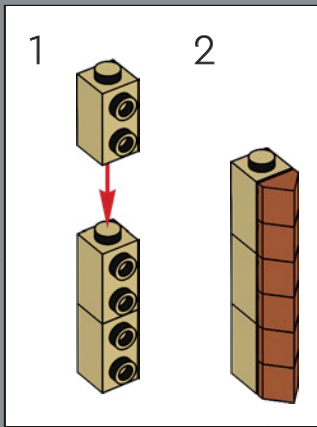

357



- 1x 
- 3x 
- 3x 
- 2x 

358

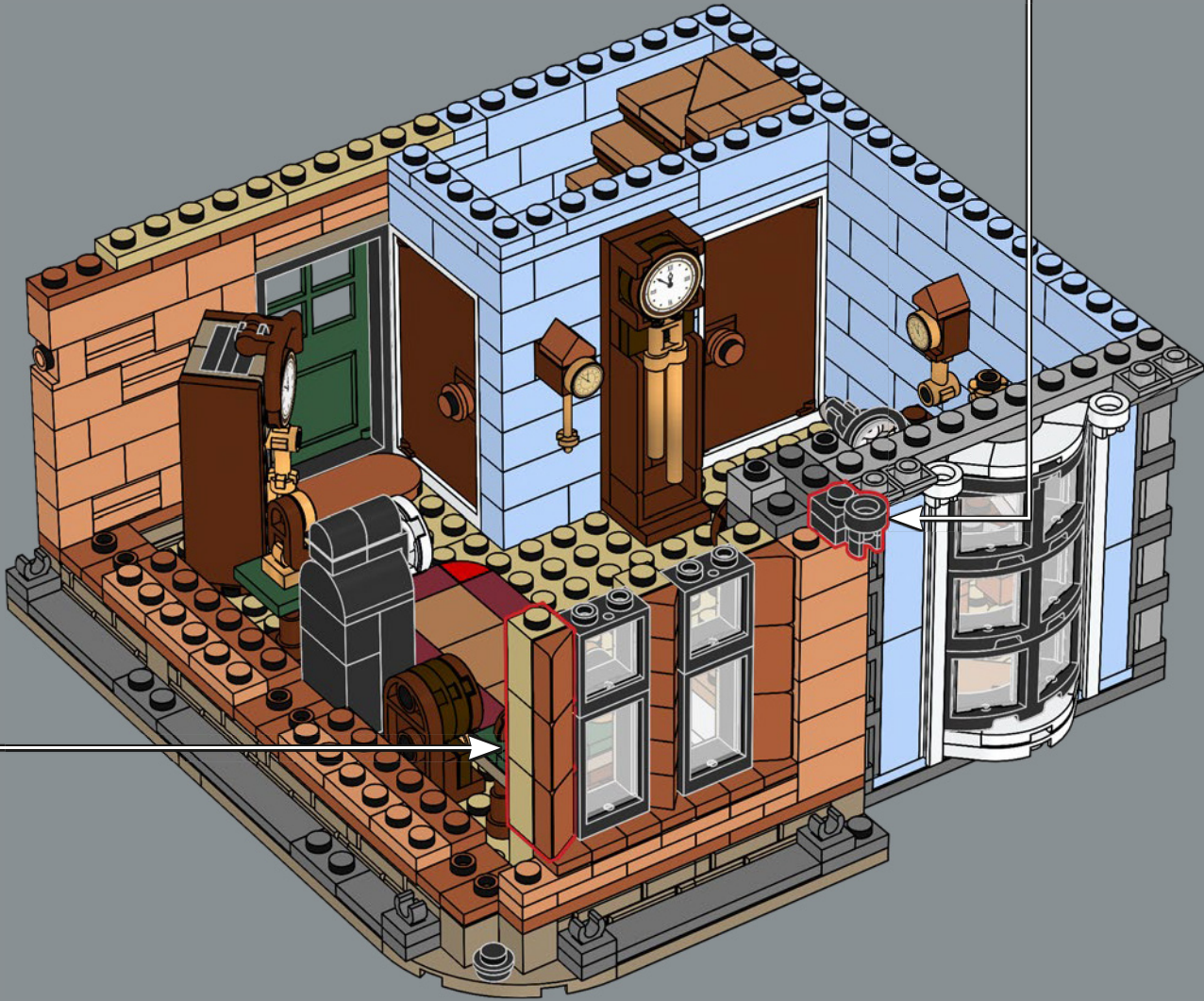
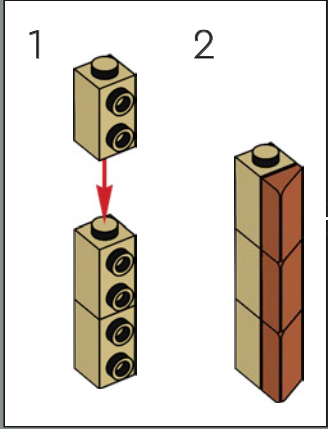
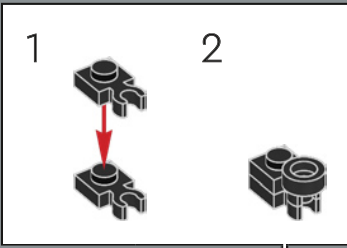

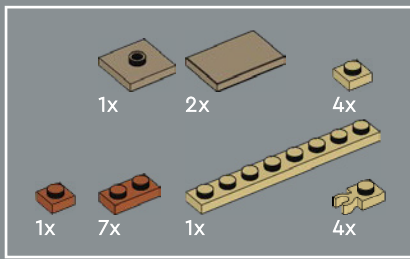

359

1

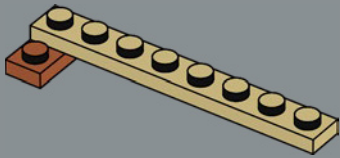

2

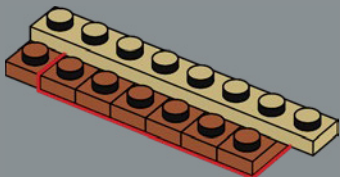

3

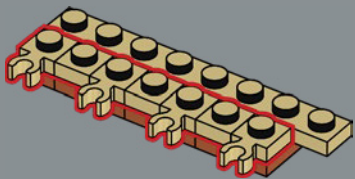

4

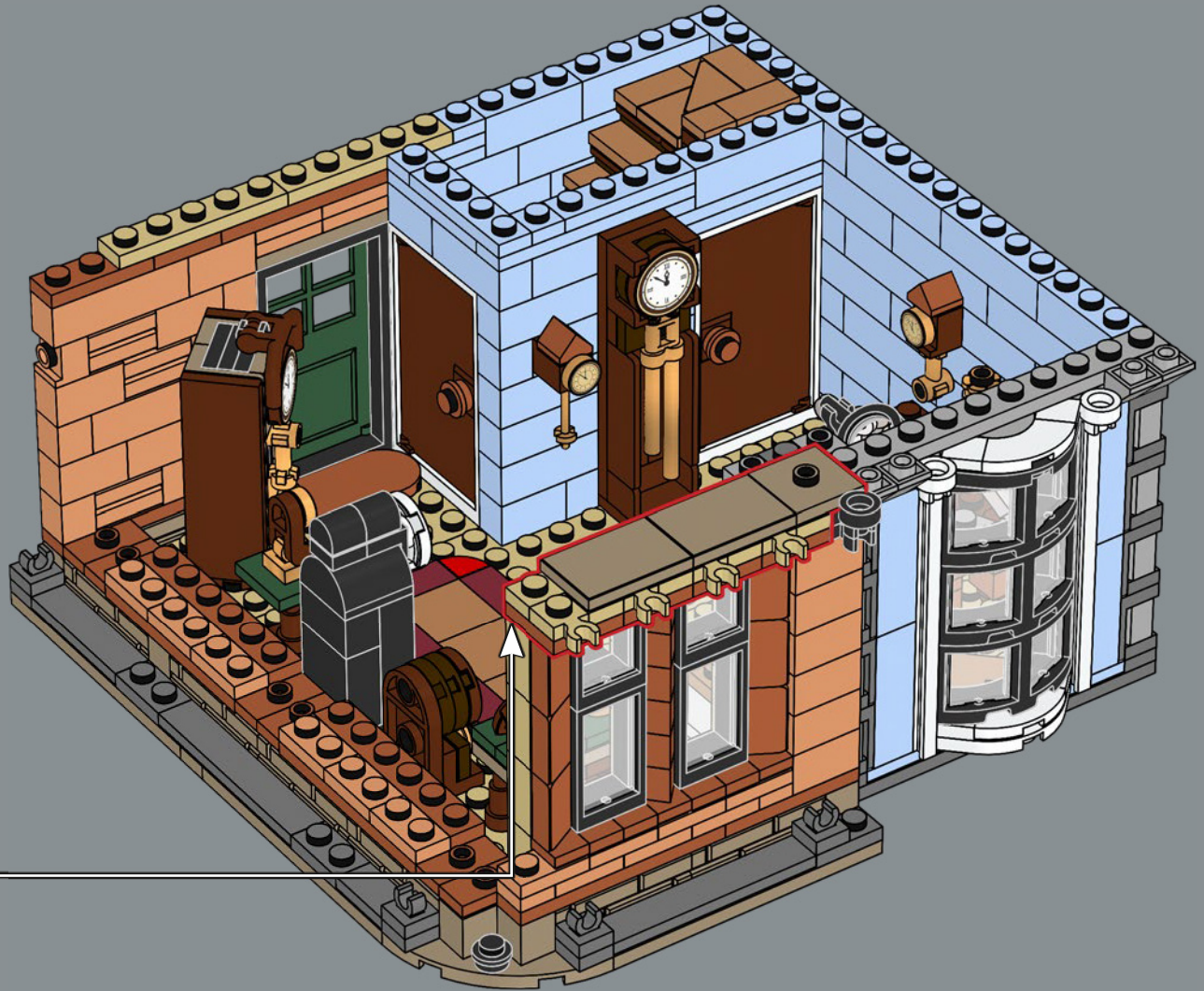
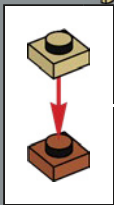
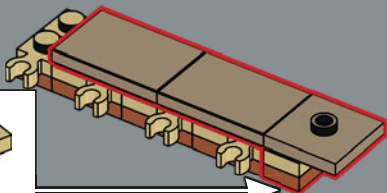

-   
1x
-   
5x
-   
5x

360

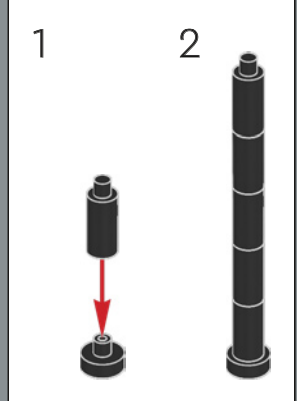
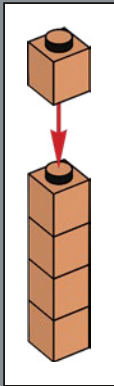
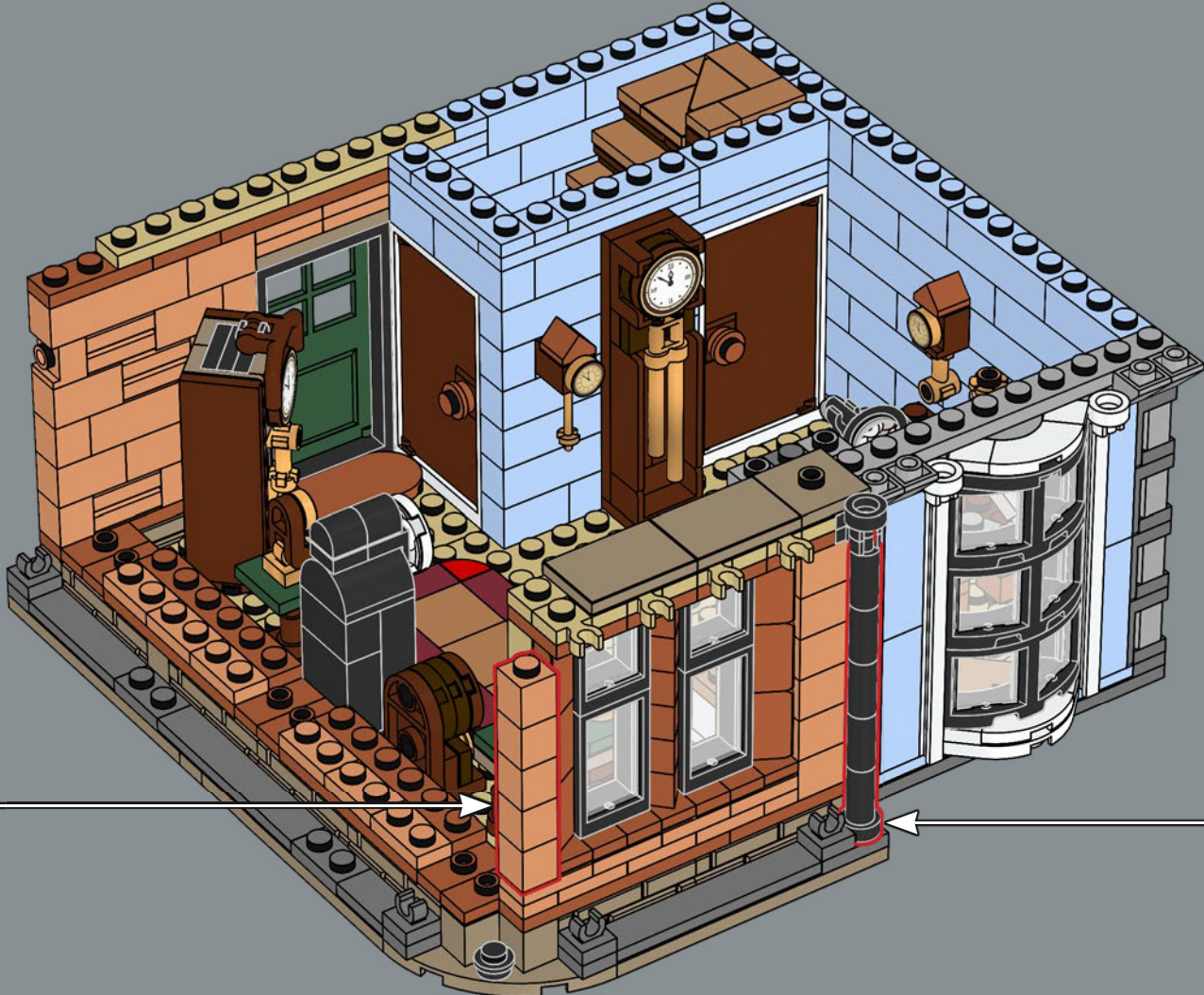

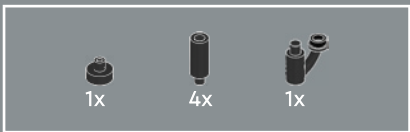

361

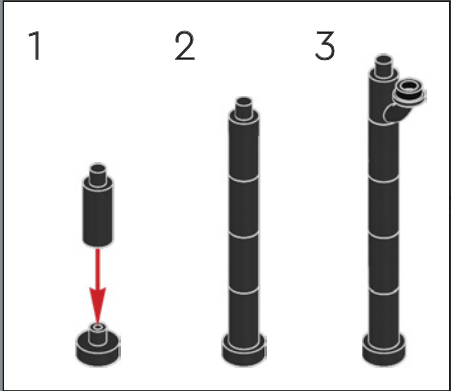
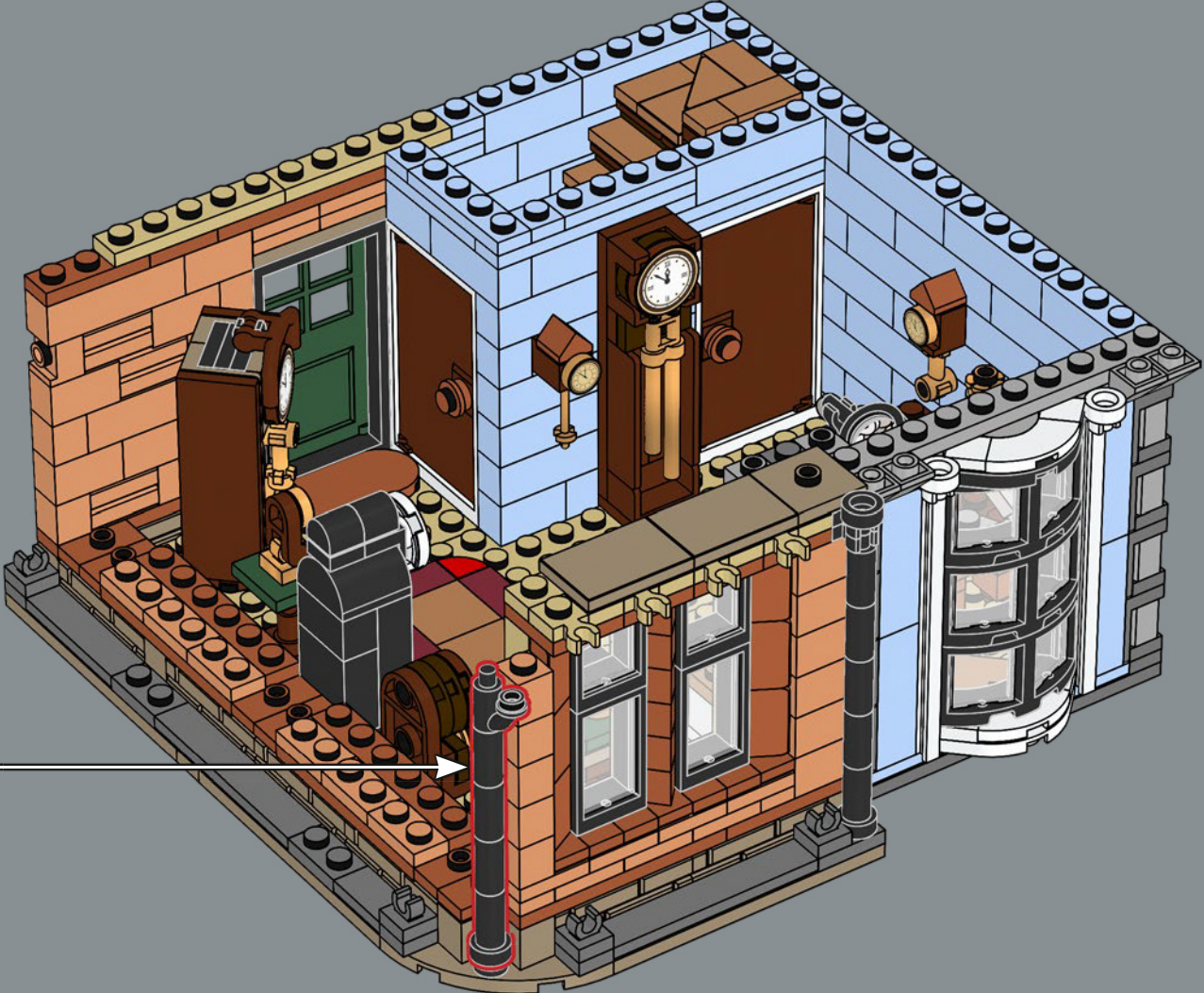

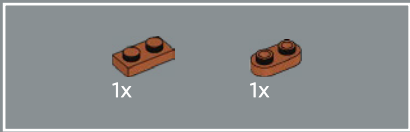

362

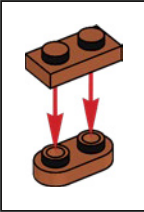
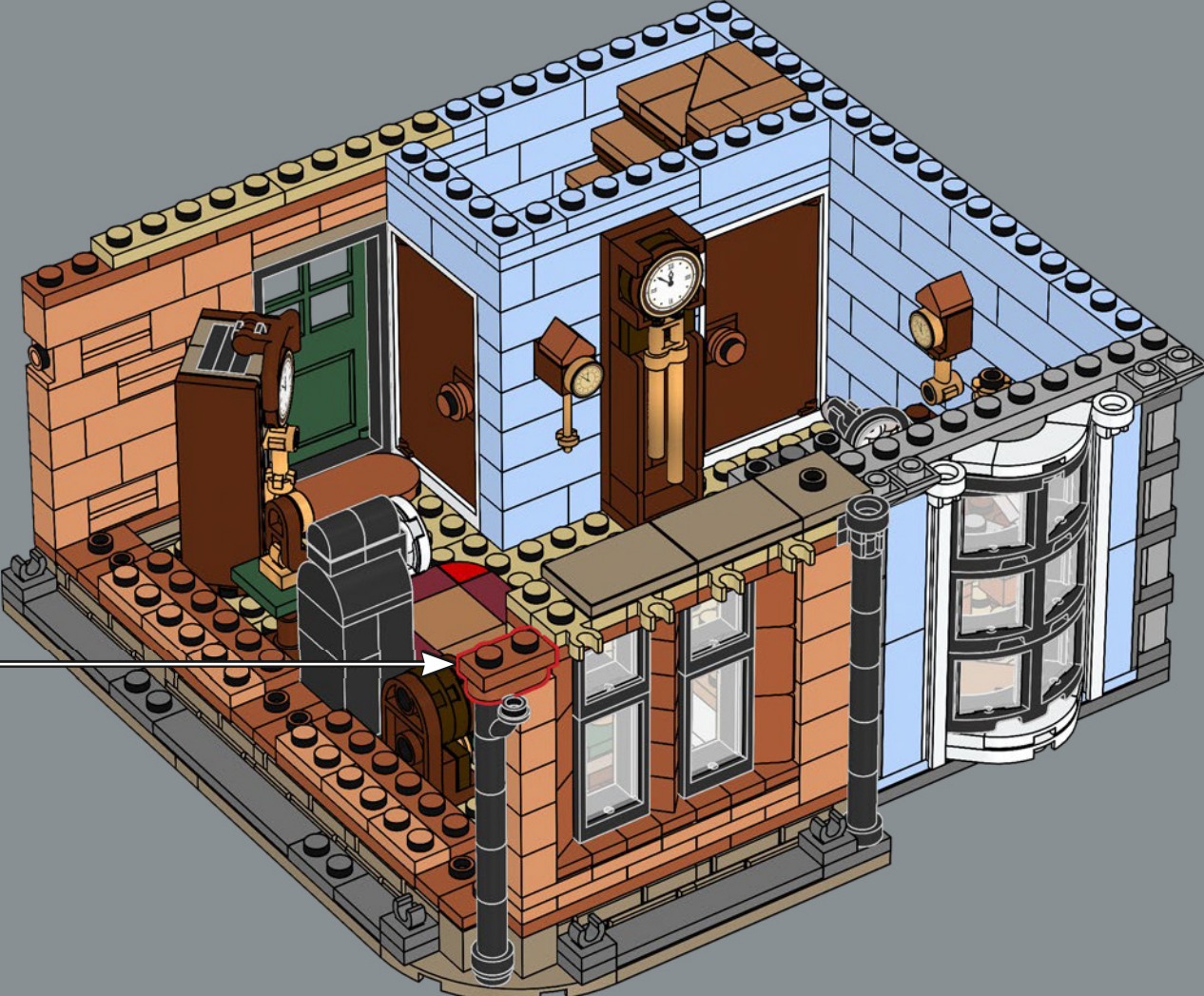

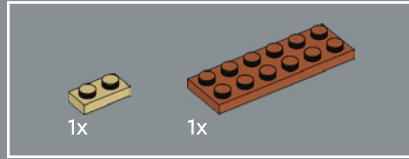
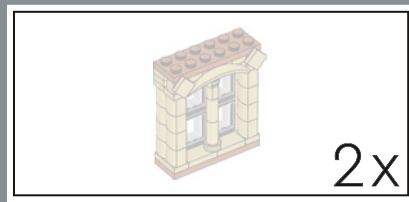

363

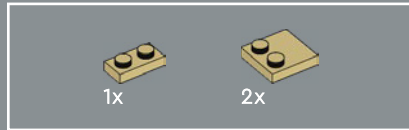
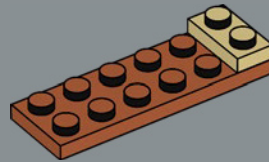

364

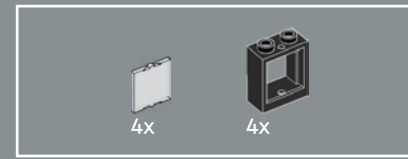
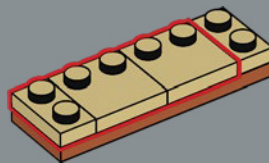

365

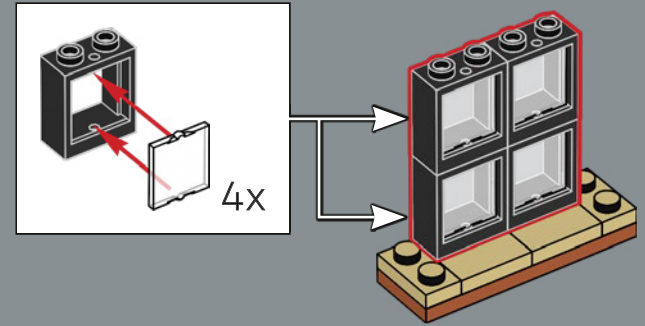

366

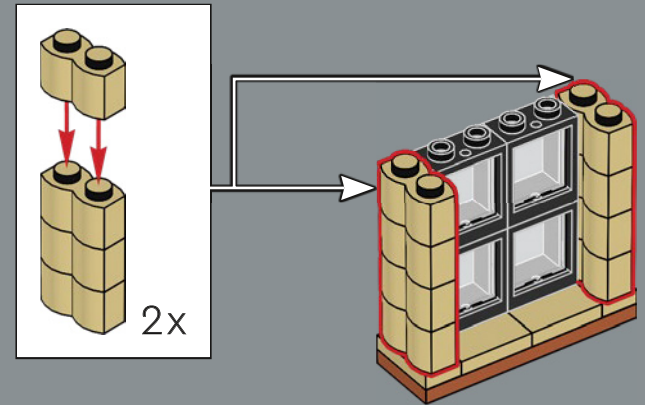

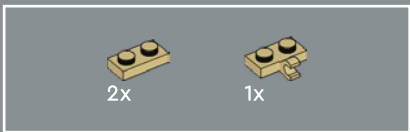

367

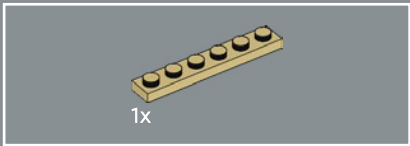
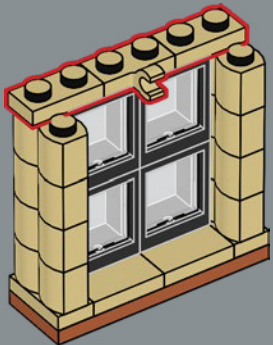

368

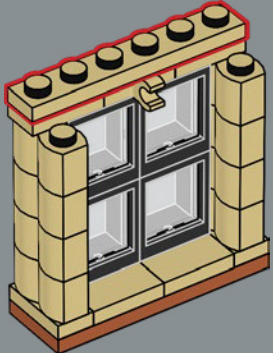

369

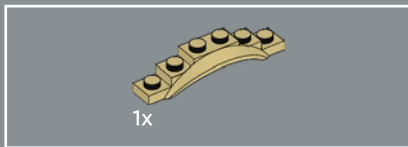
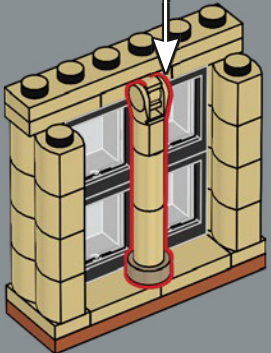
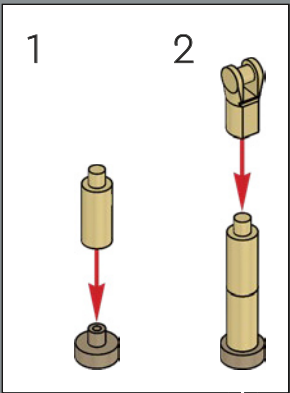

370

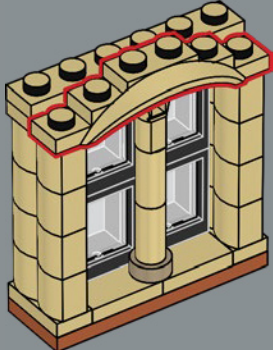

371

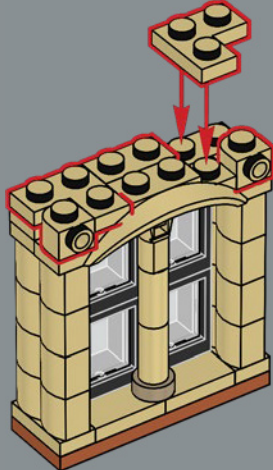



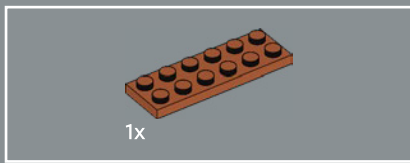

1x

372

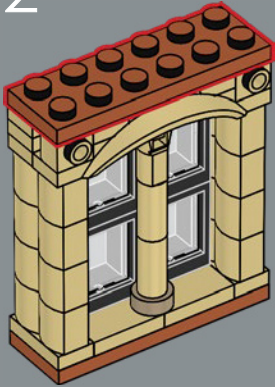

2x

373

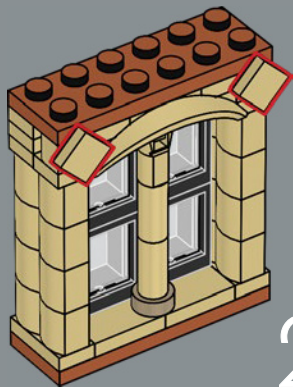

2x



374

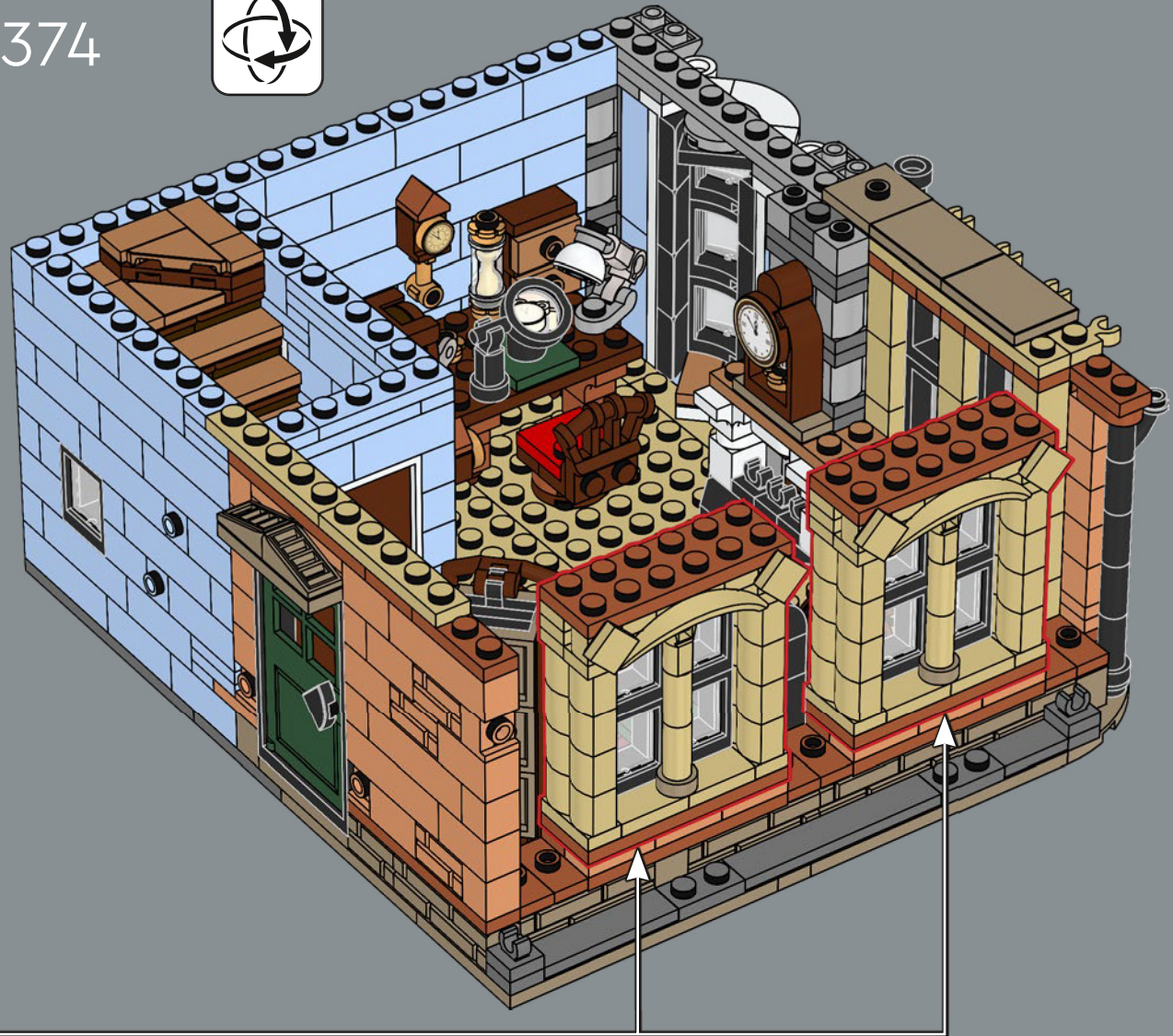

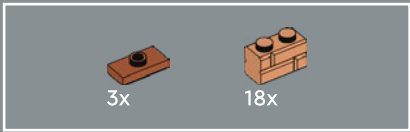

375

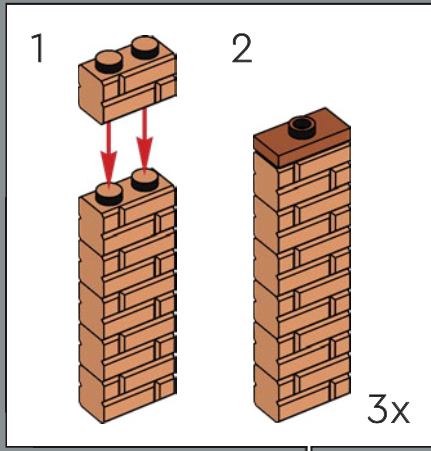
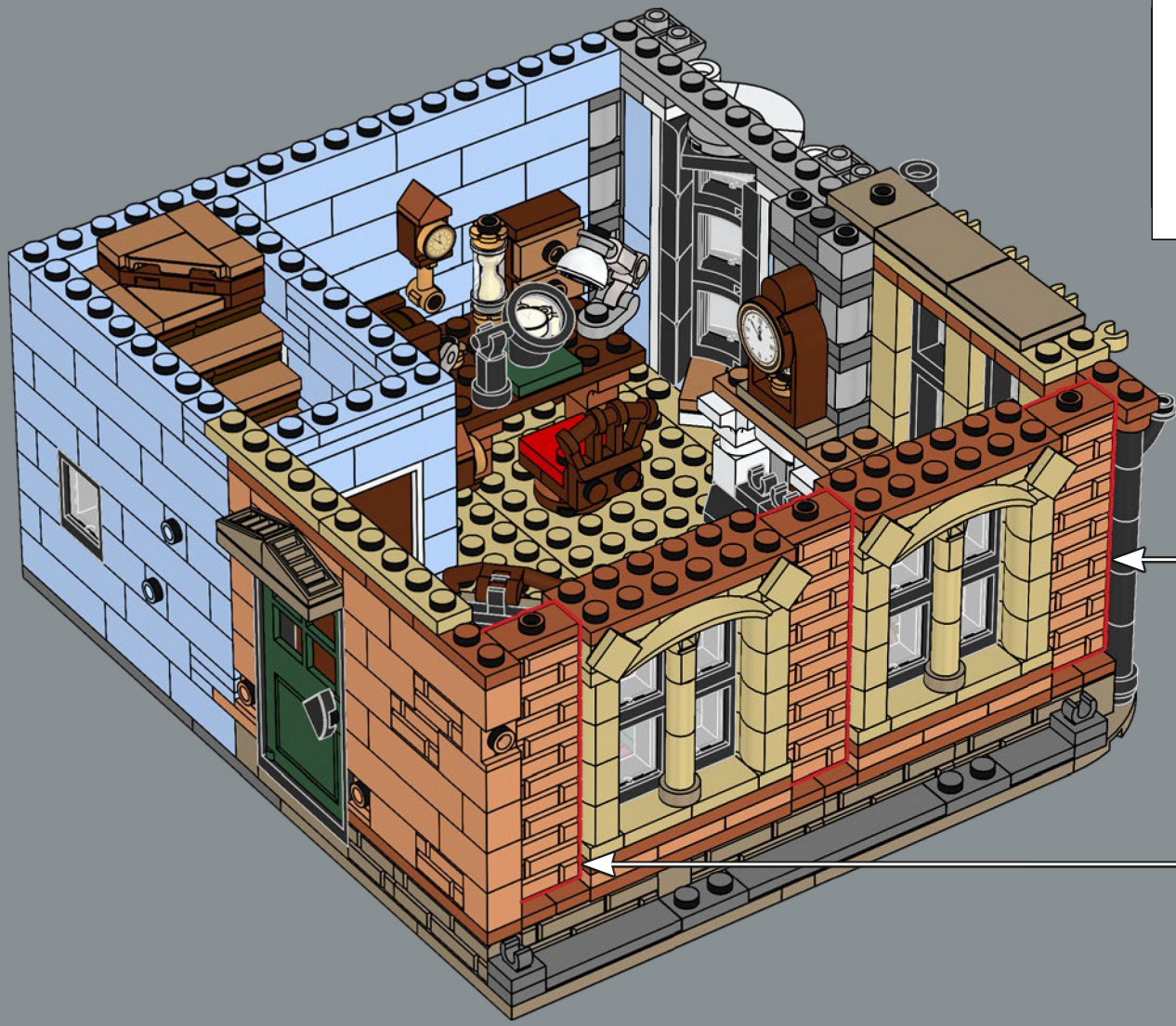

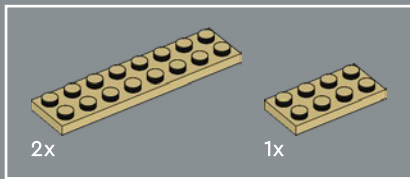

376



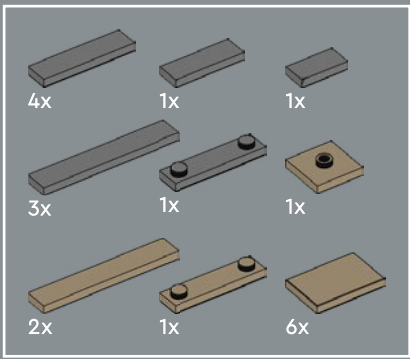

377





378

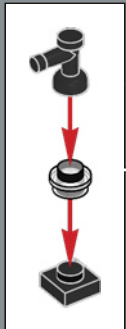
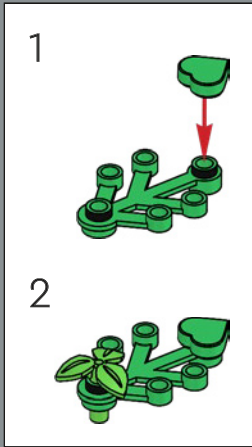

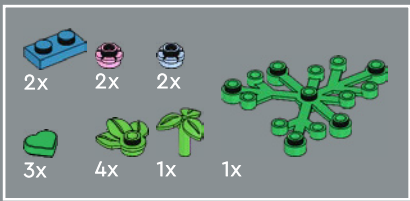

379

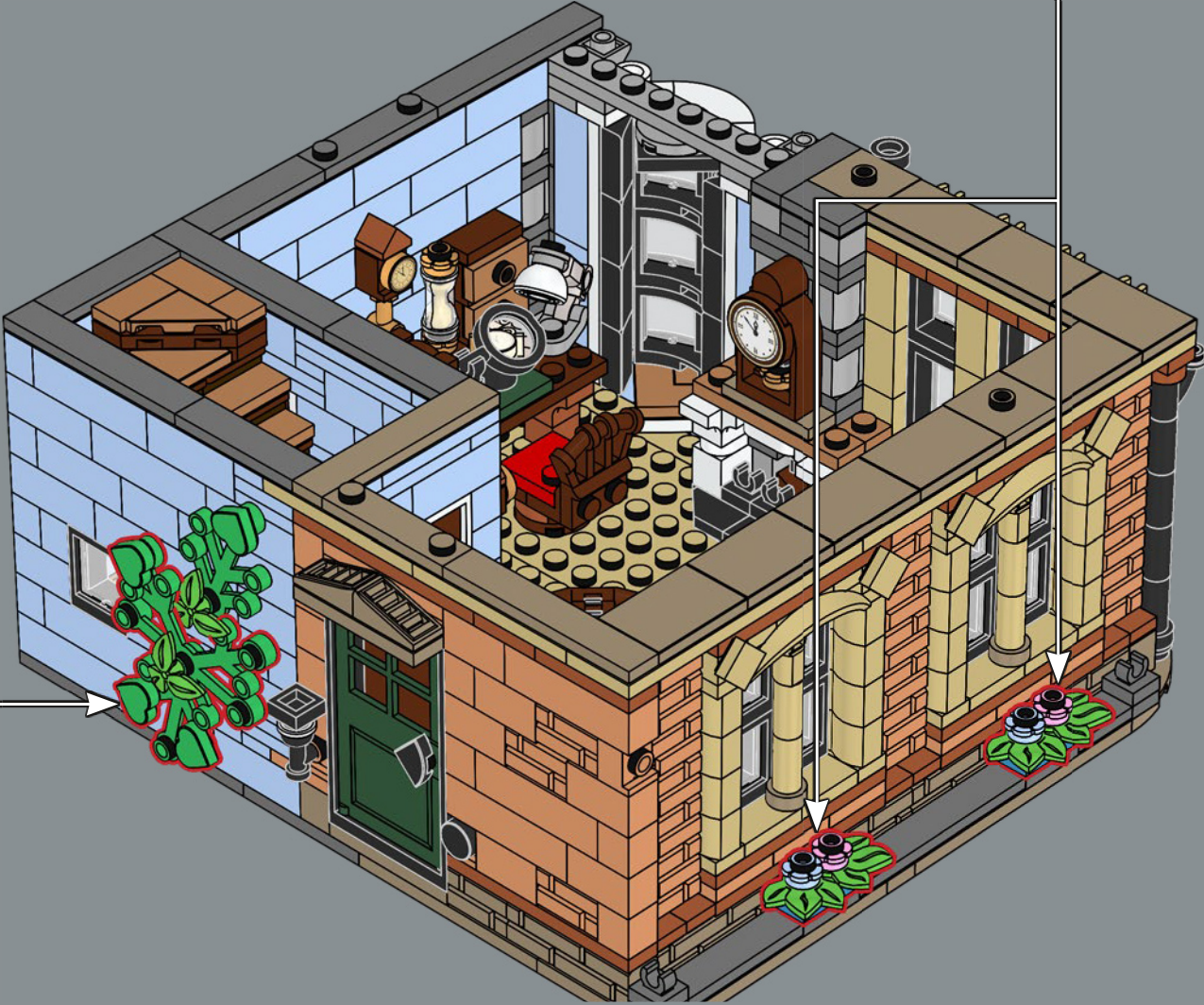
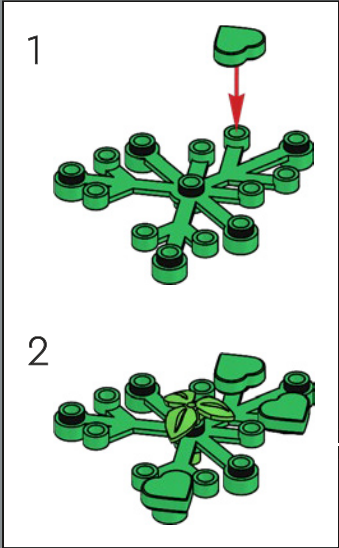
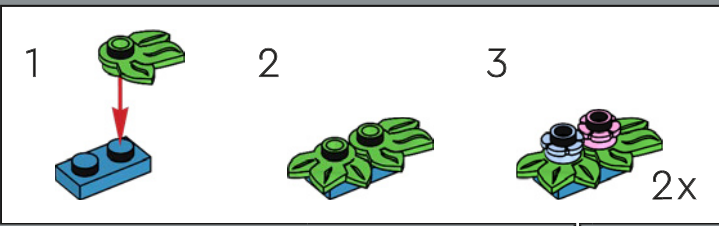

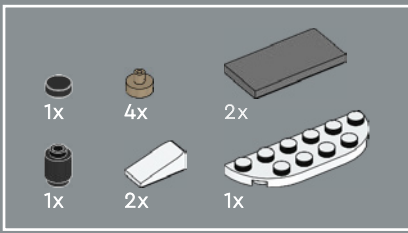

380

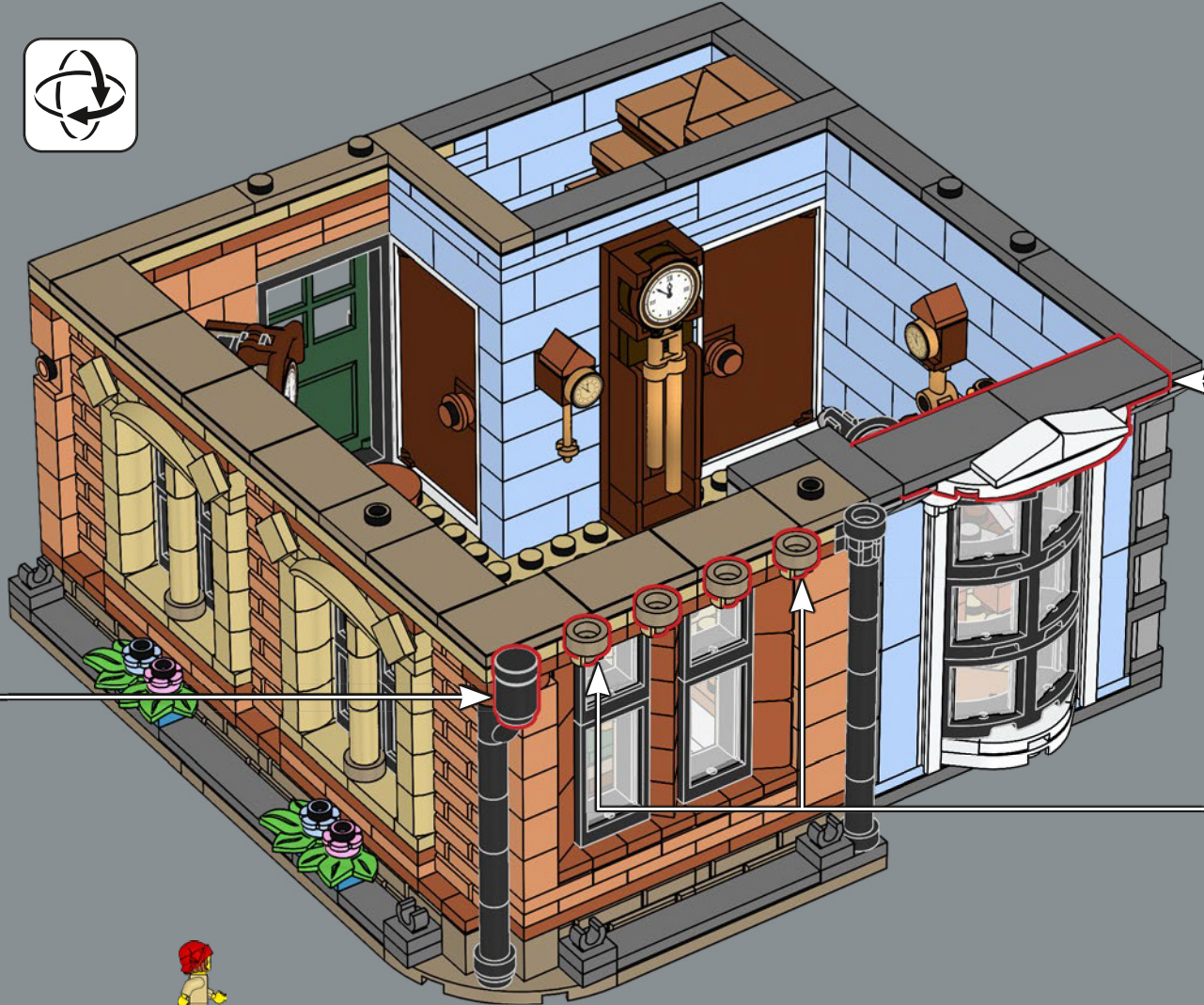
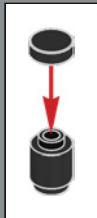
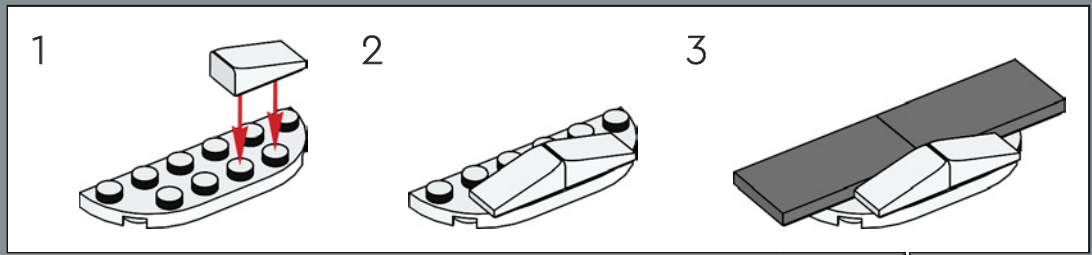



381

1

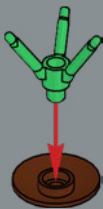

2



3

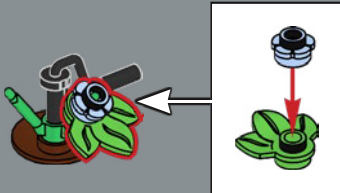

4

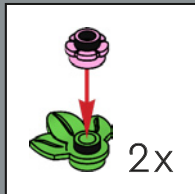

4x





382



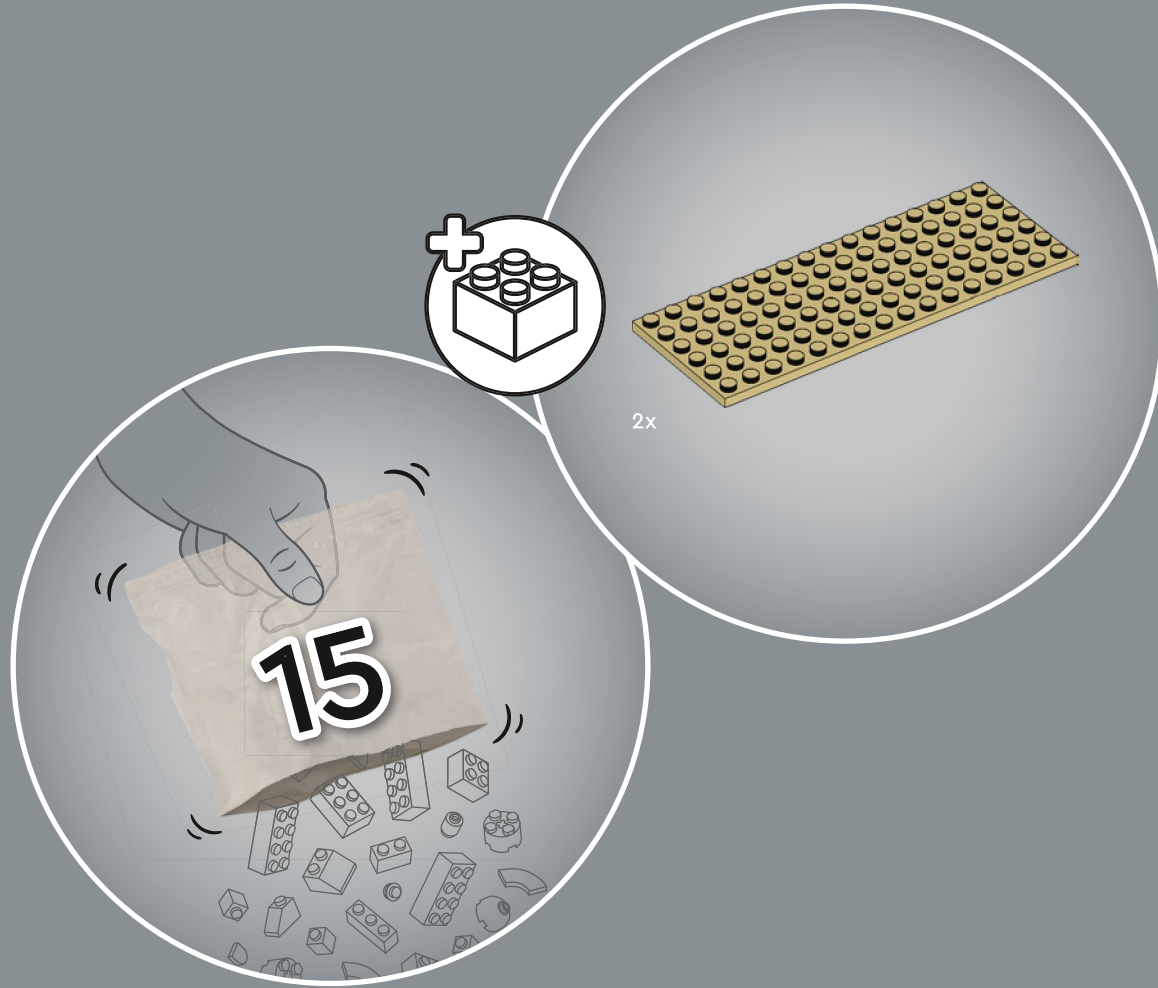

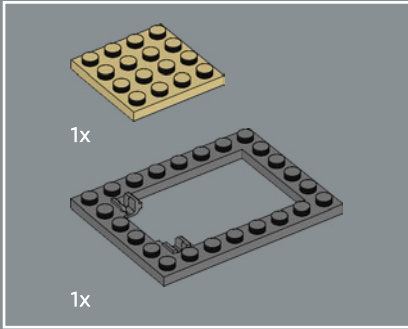
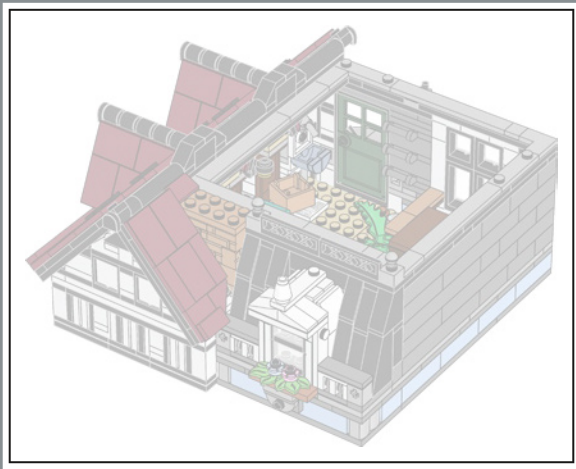

383

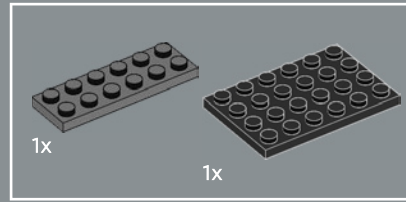
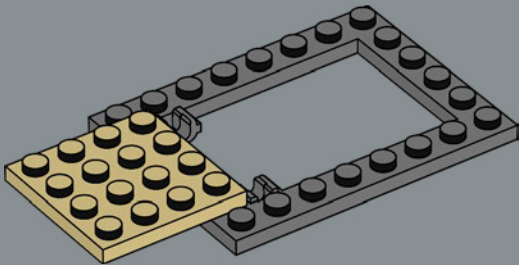

384

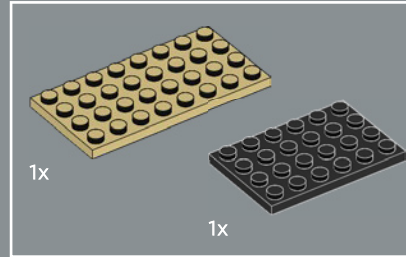
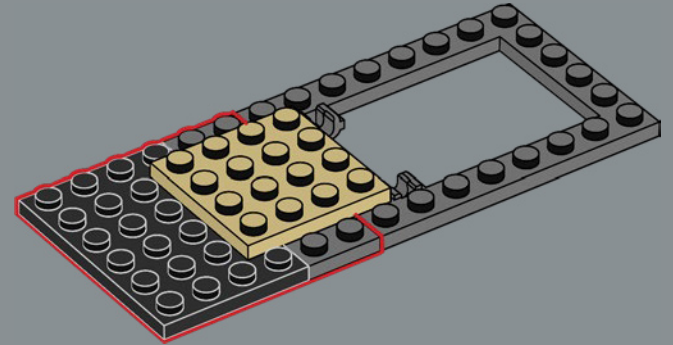

385

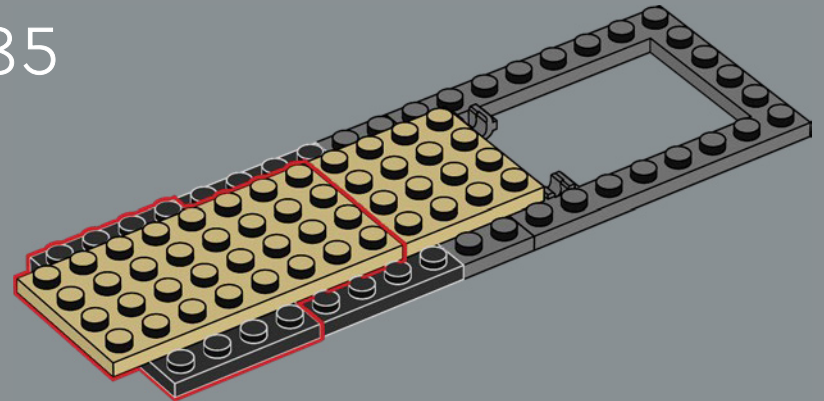

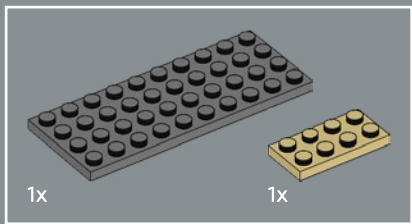

386

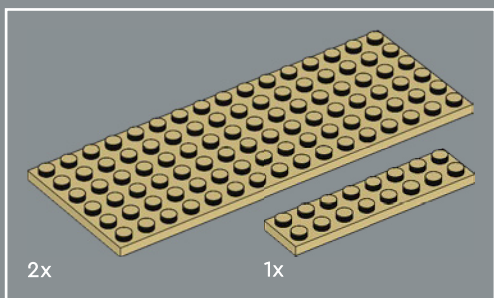
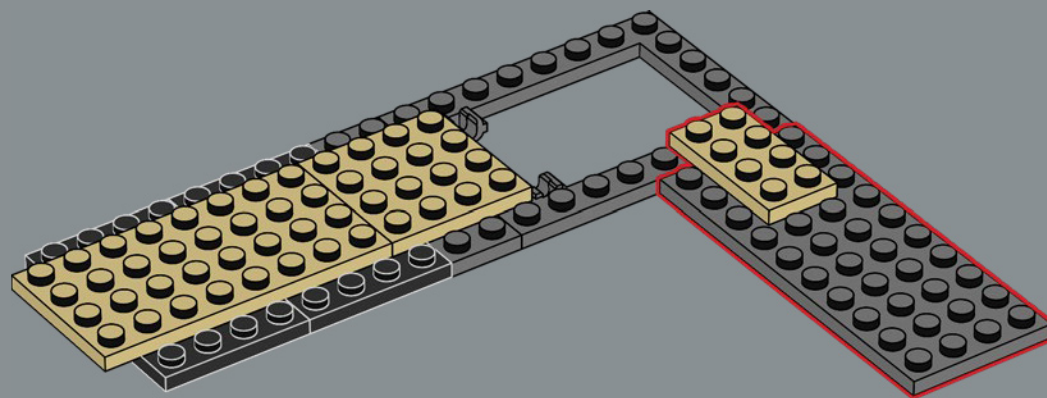

387

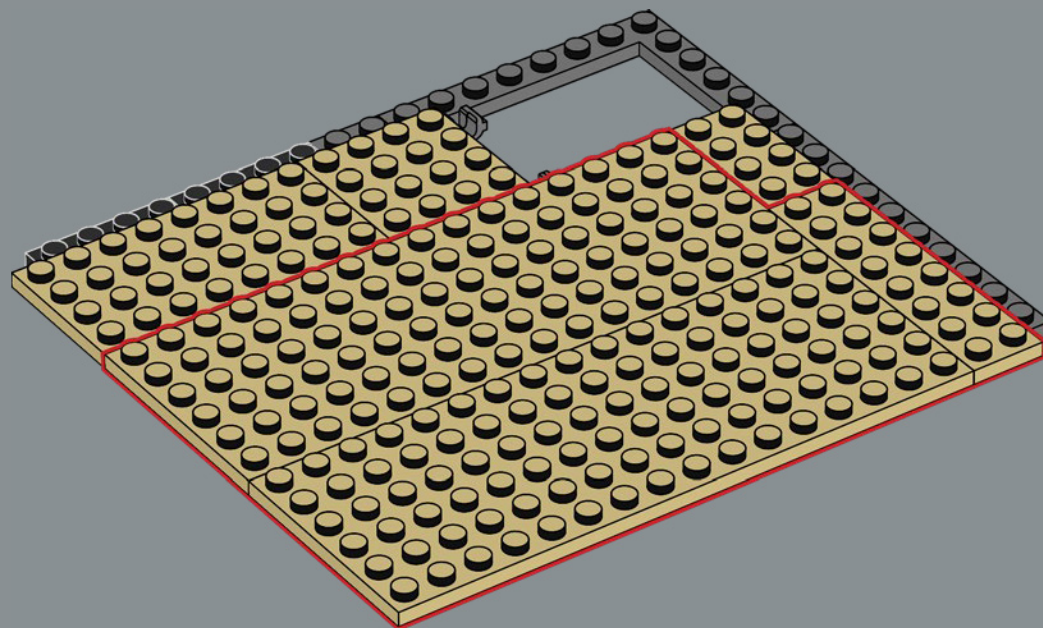

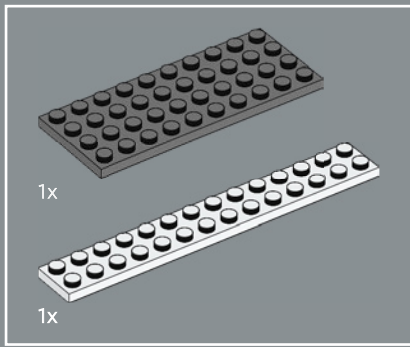

388

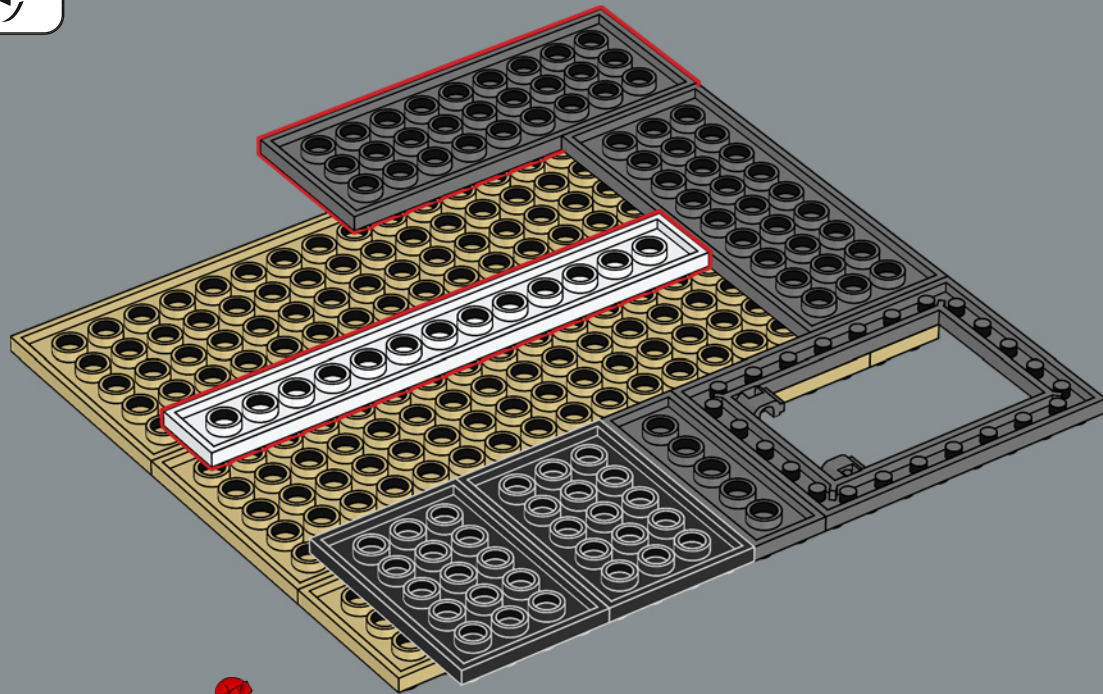

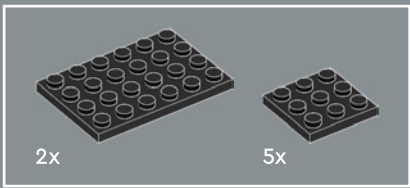

389

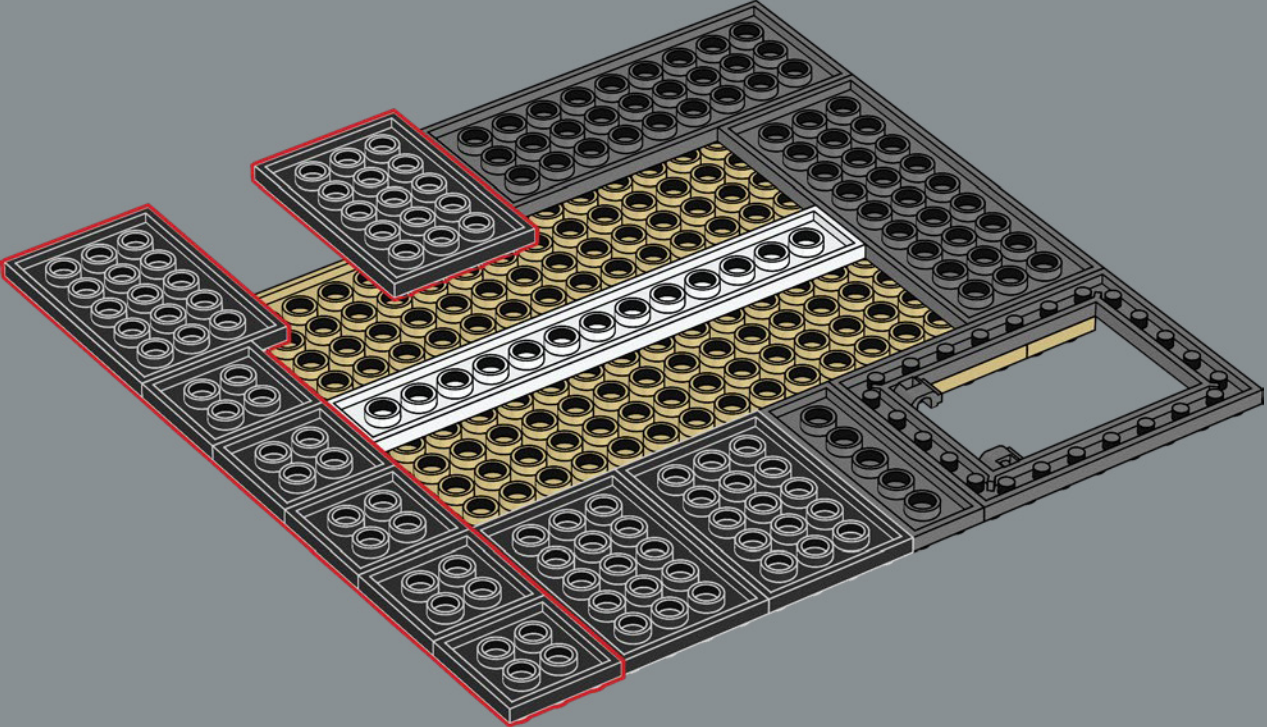

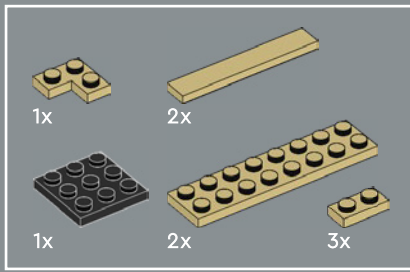

390

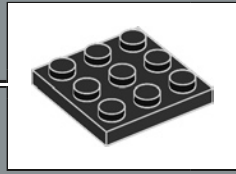
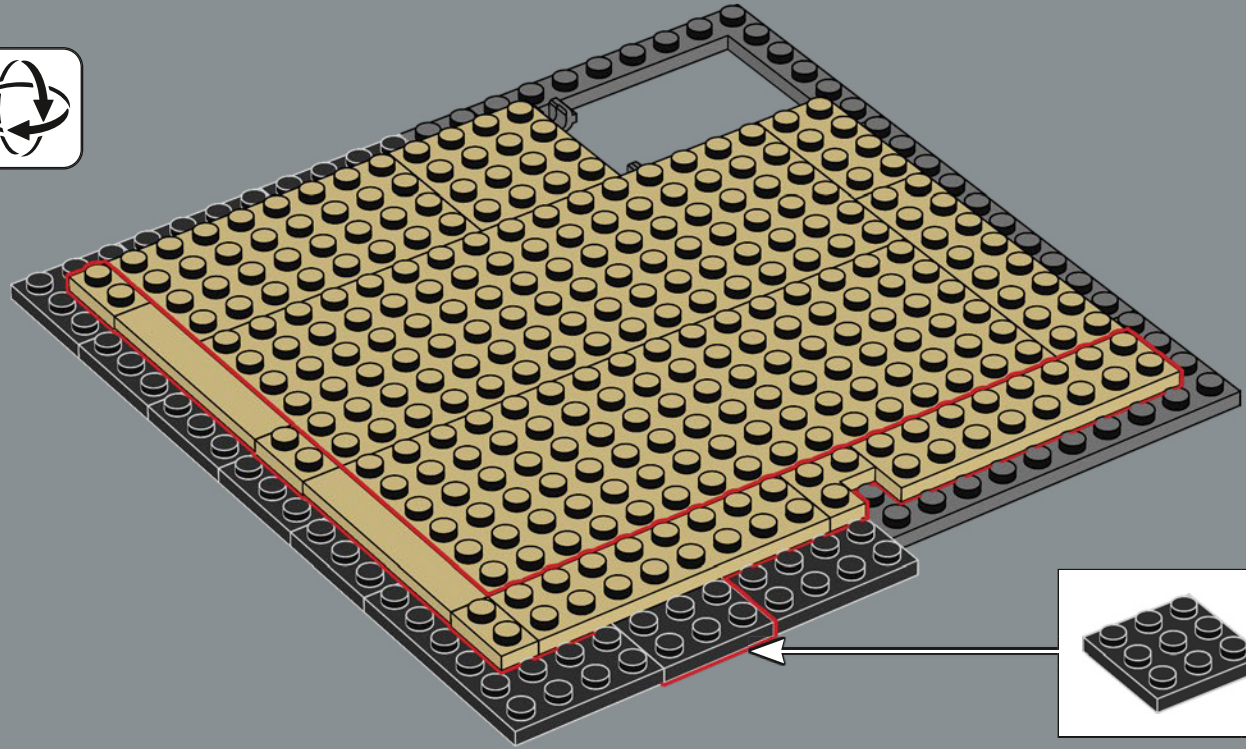

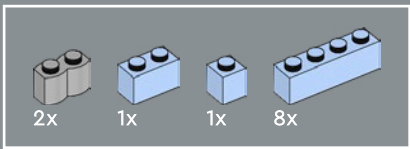

391

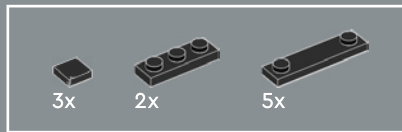
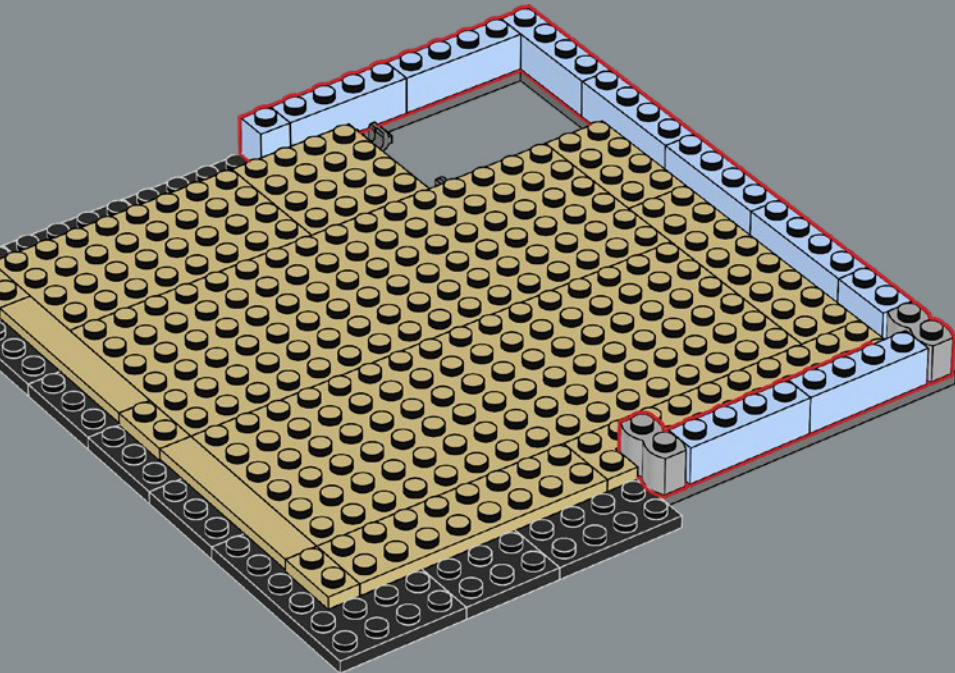

392

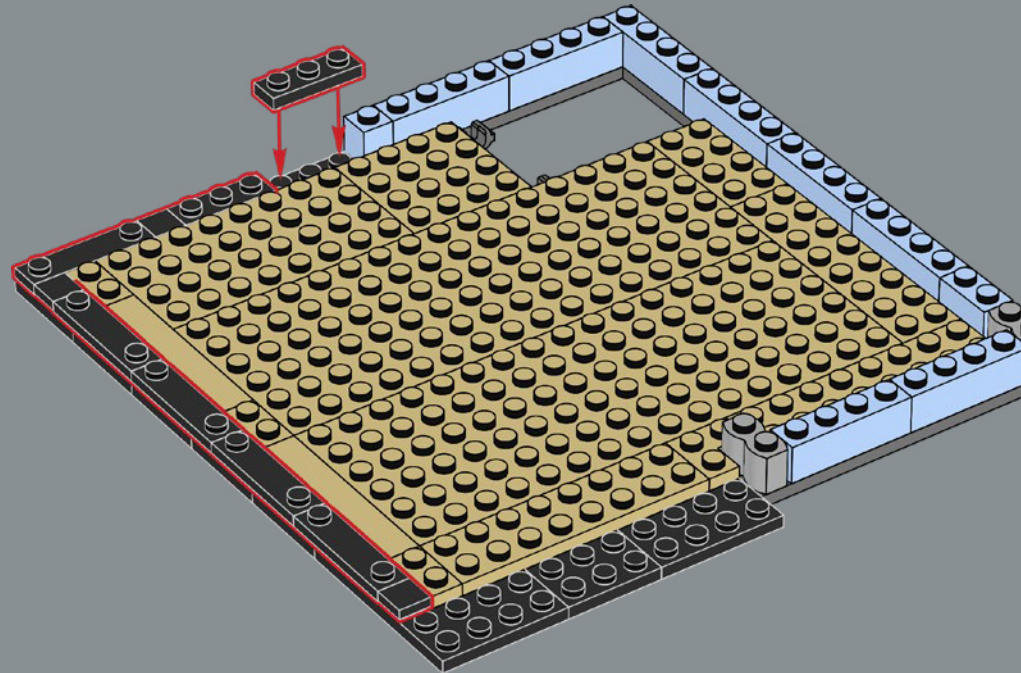



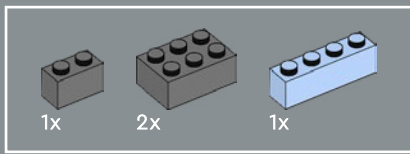

393

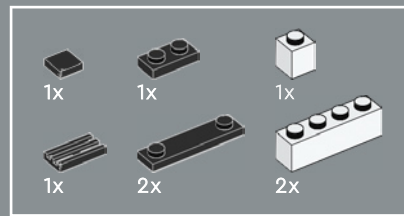
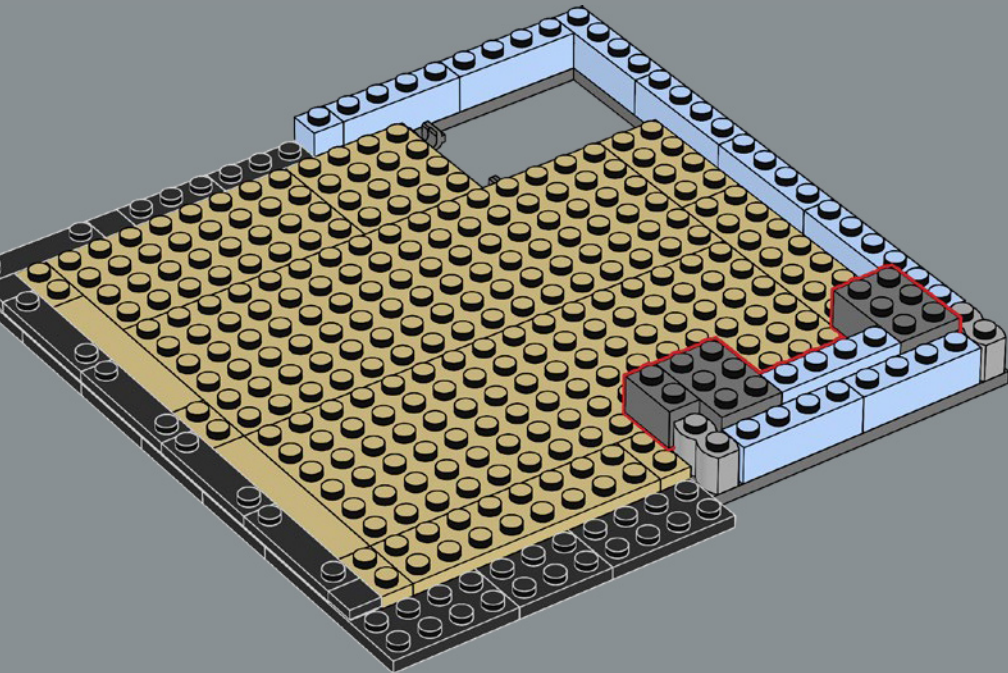

394

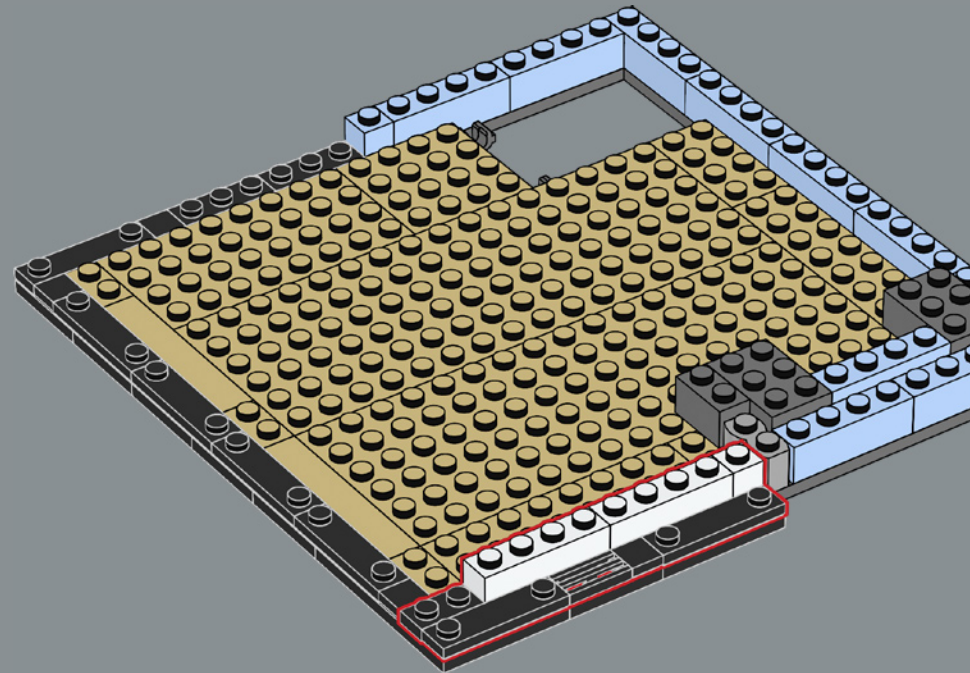

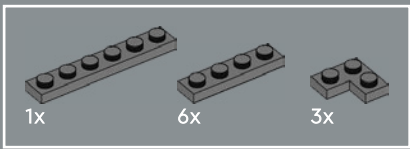

395

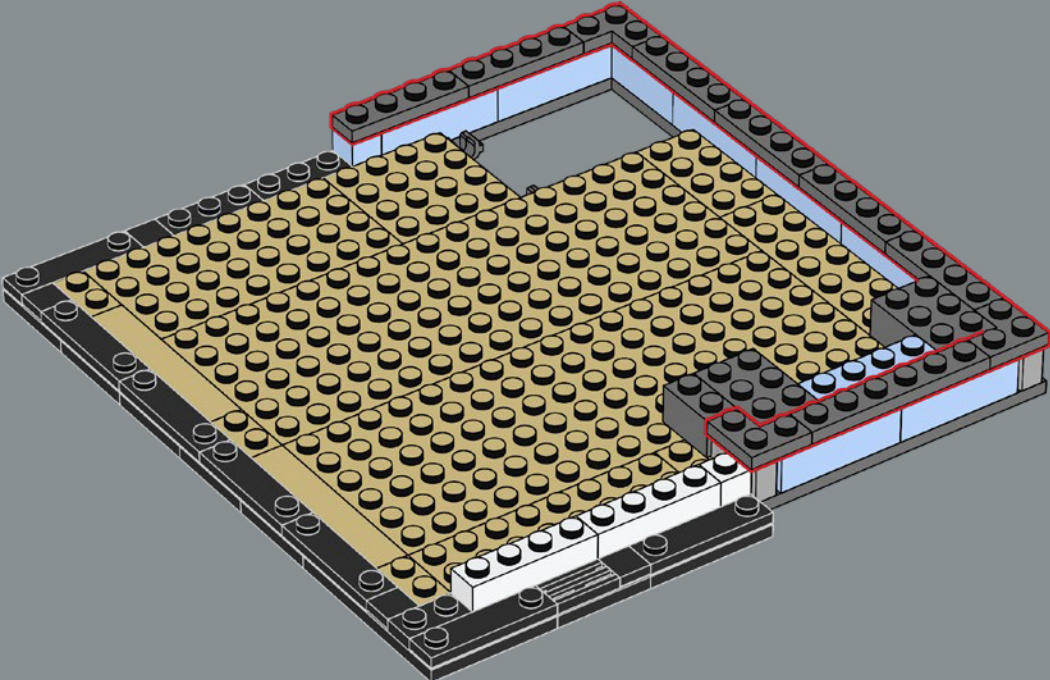

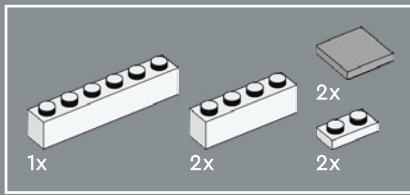

396

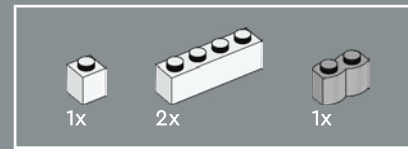
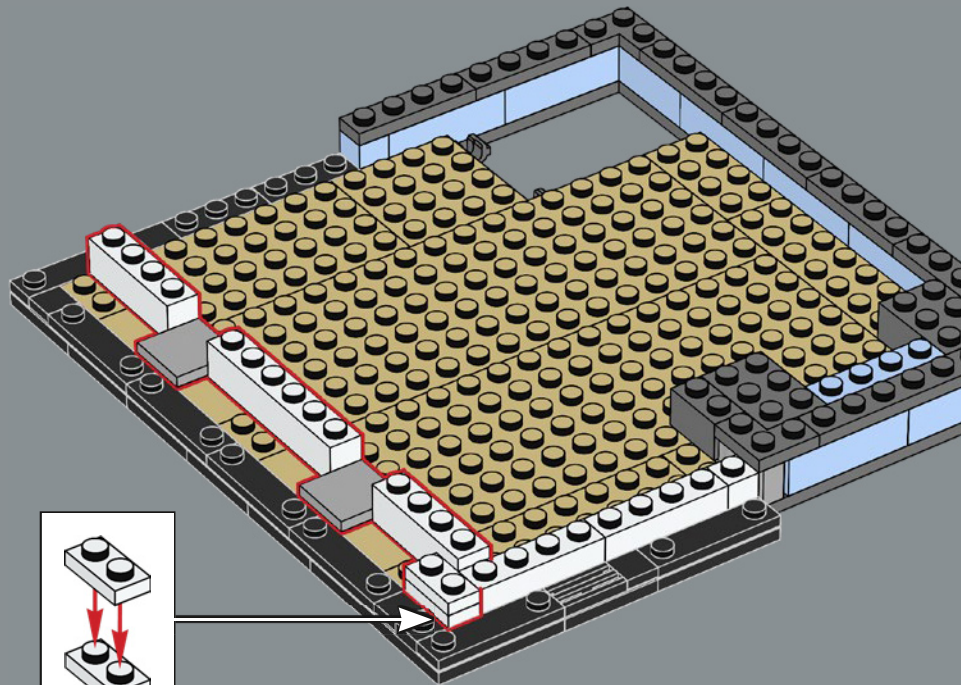

397

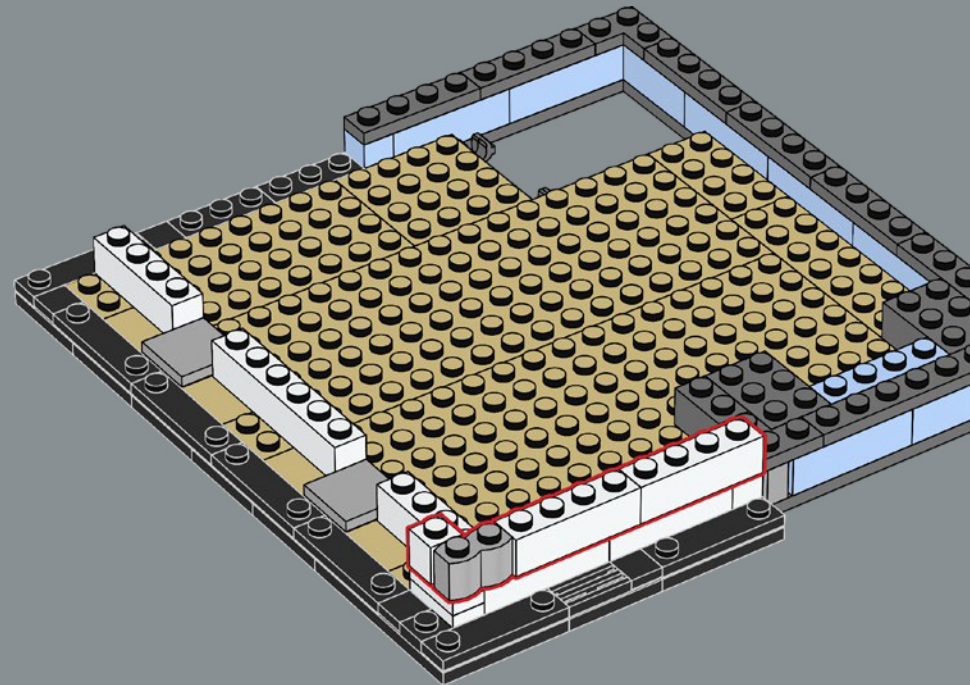

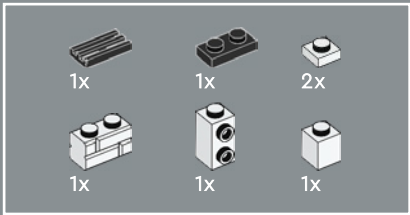

398

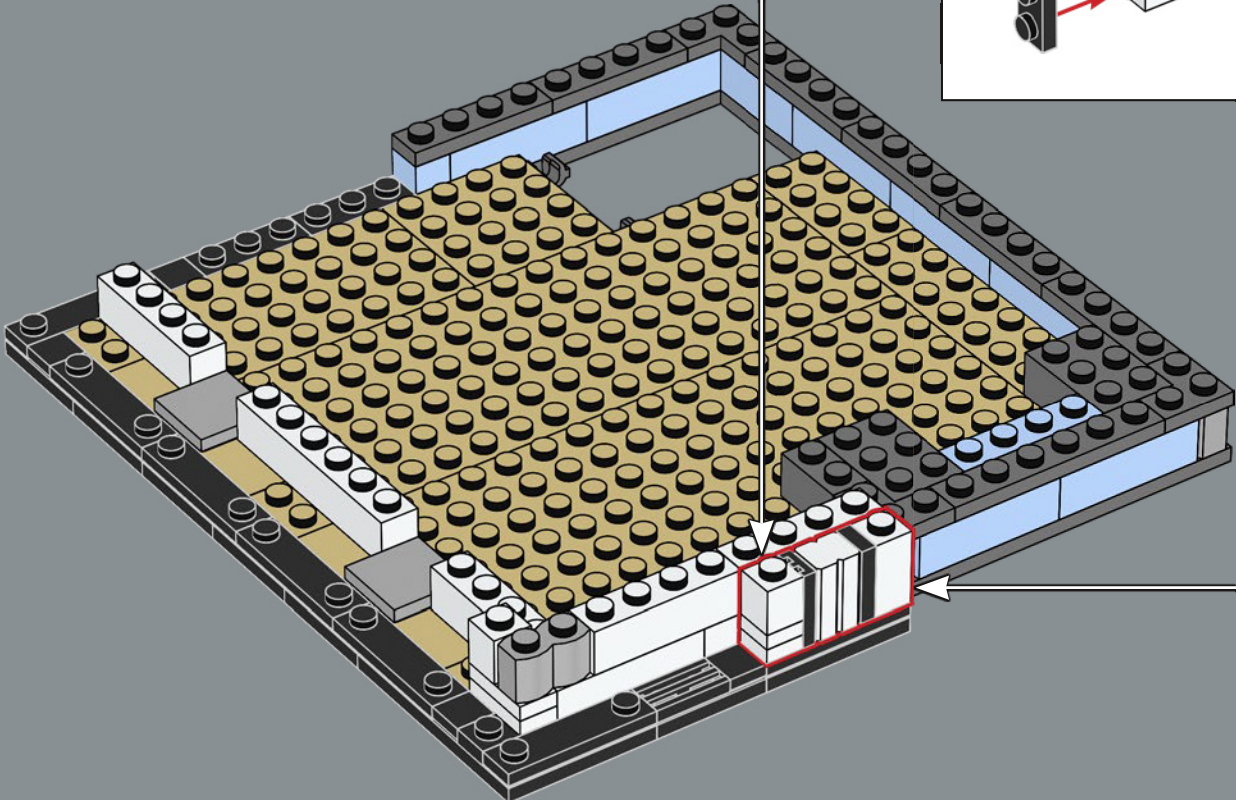
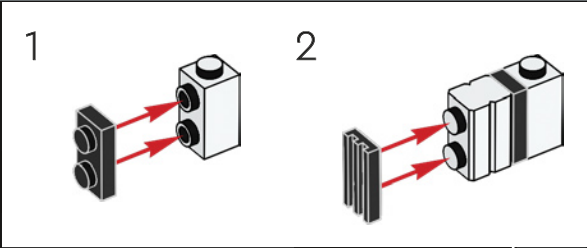
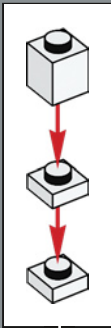

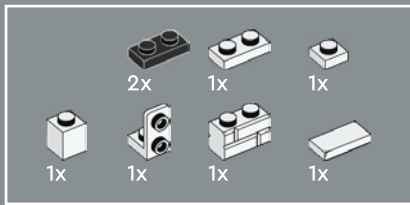

399

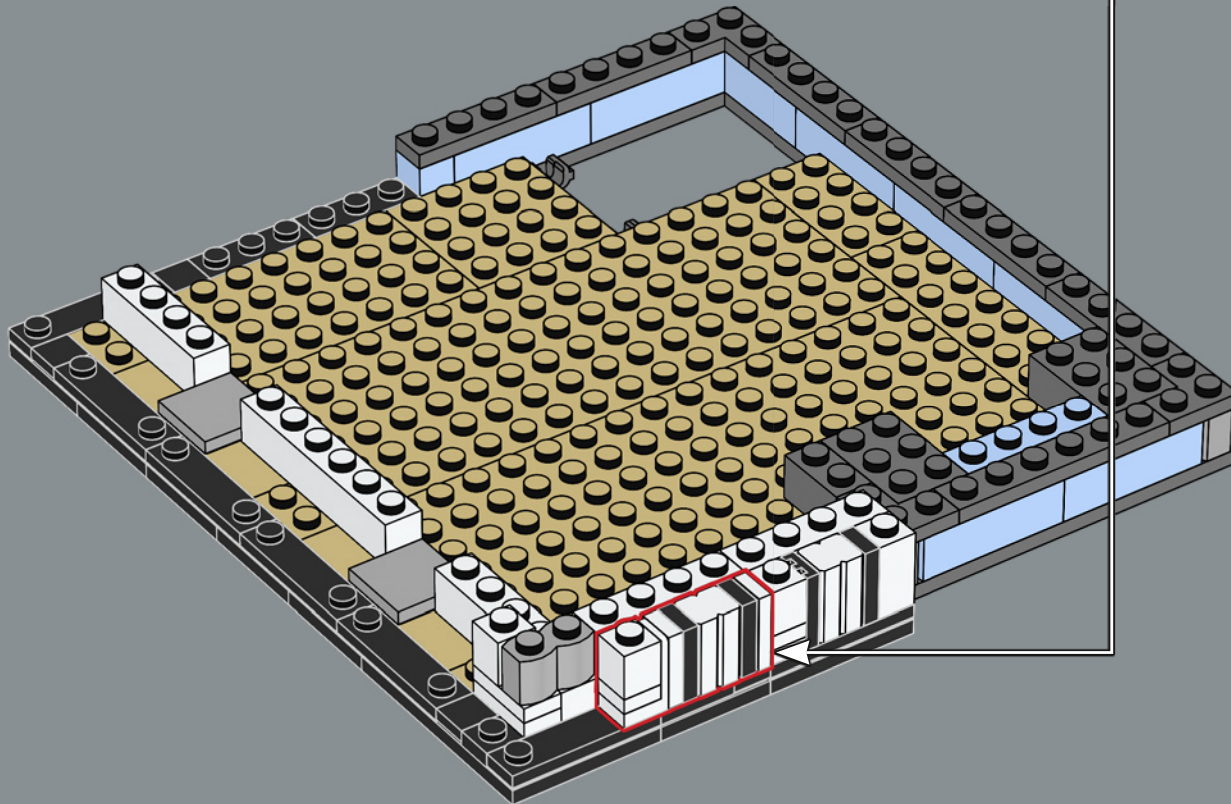
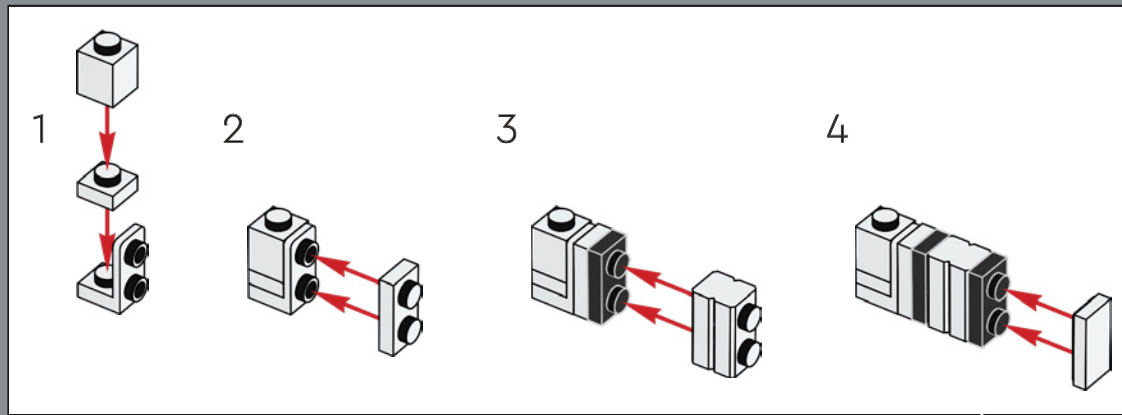

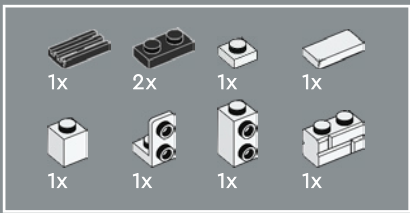

400

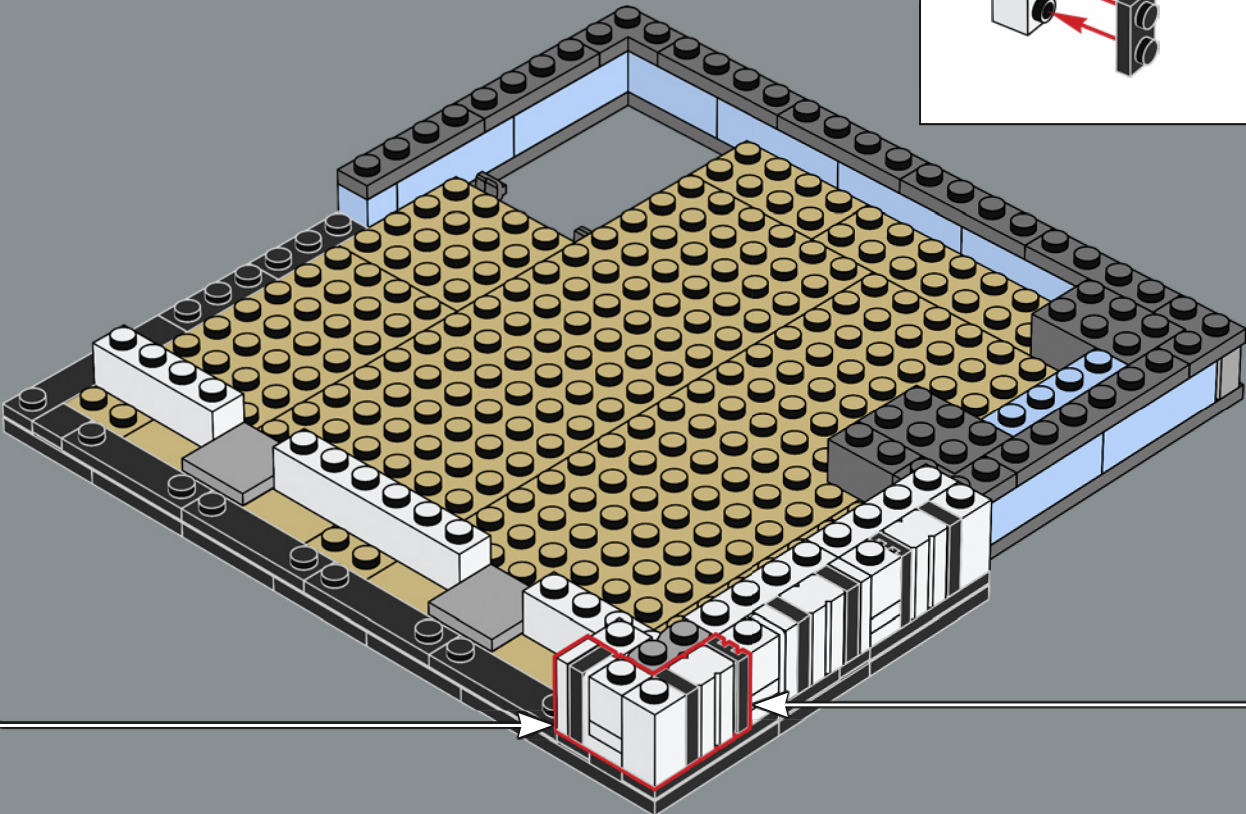
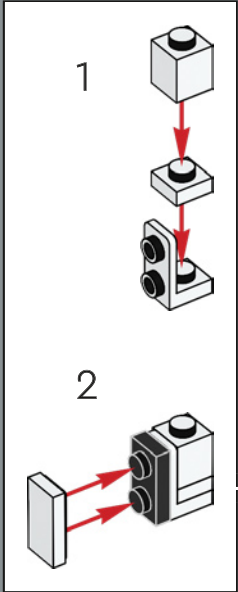
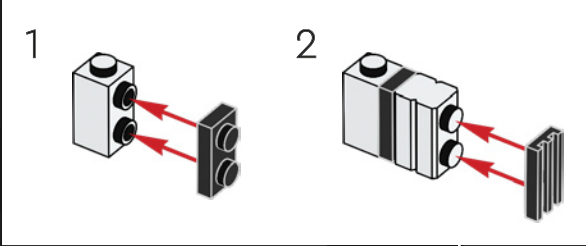

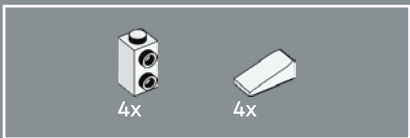

401

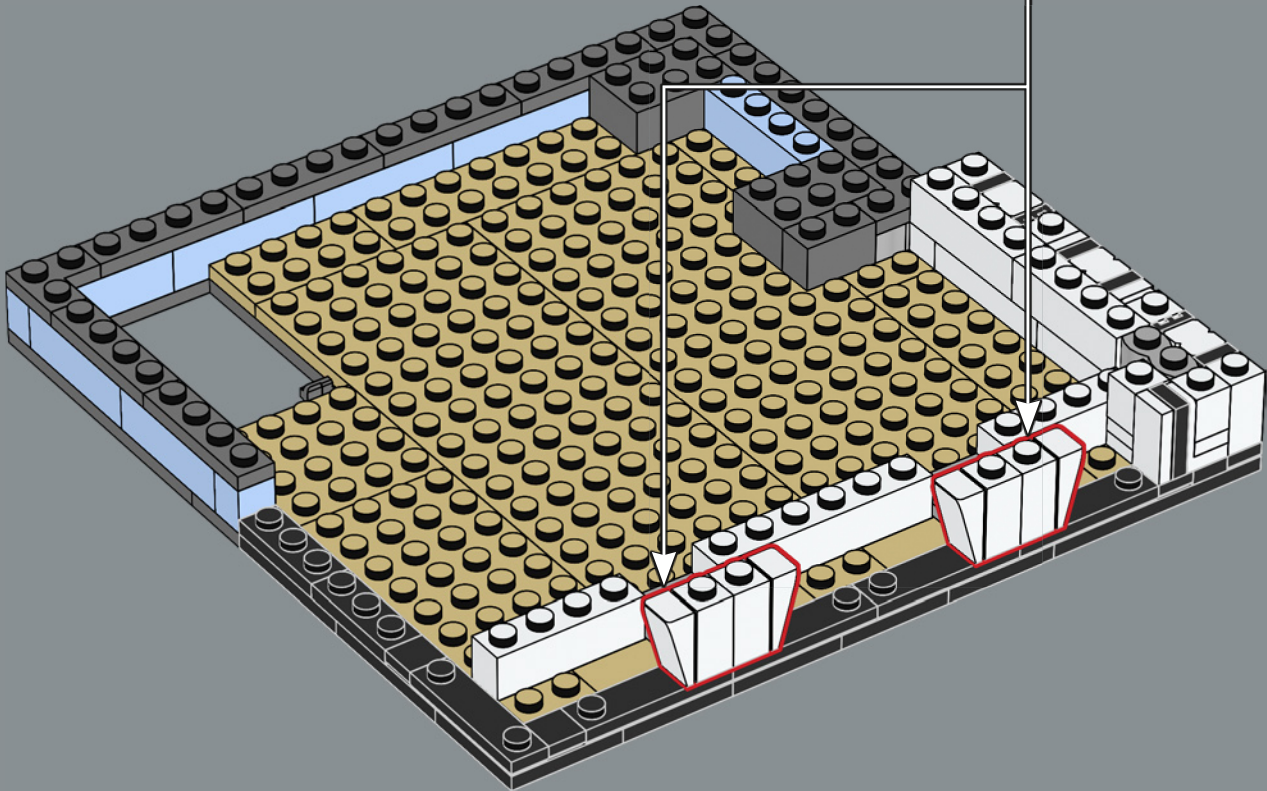
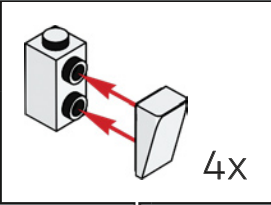

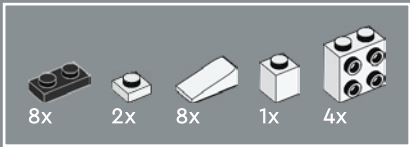

402

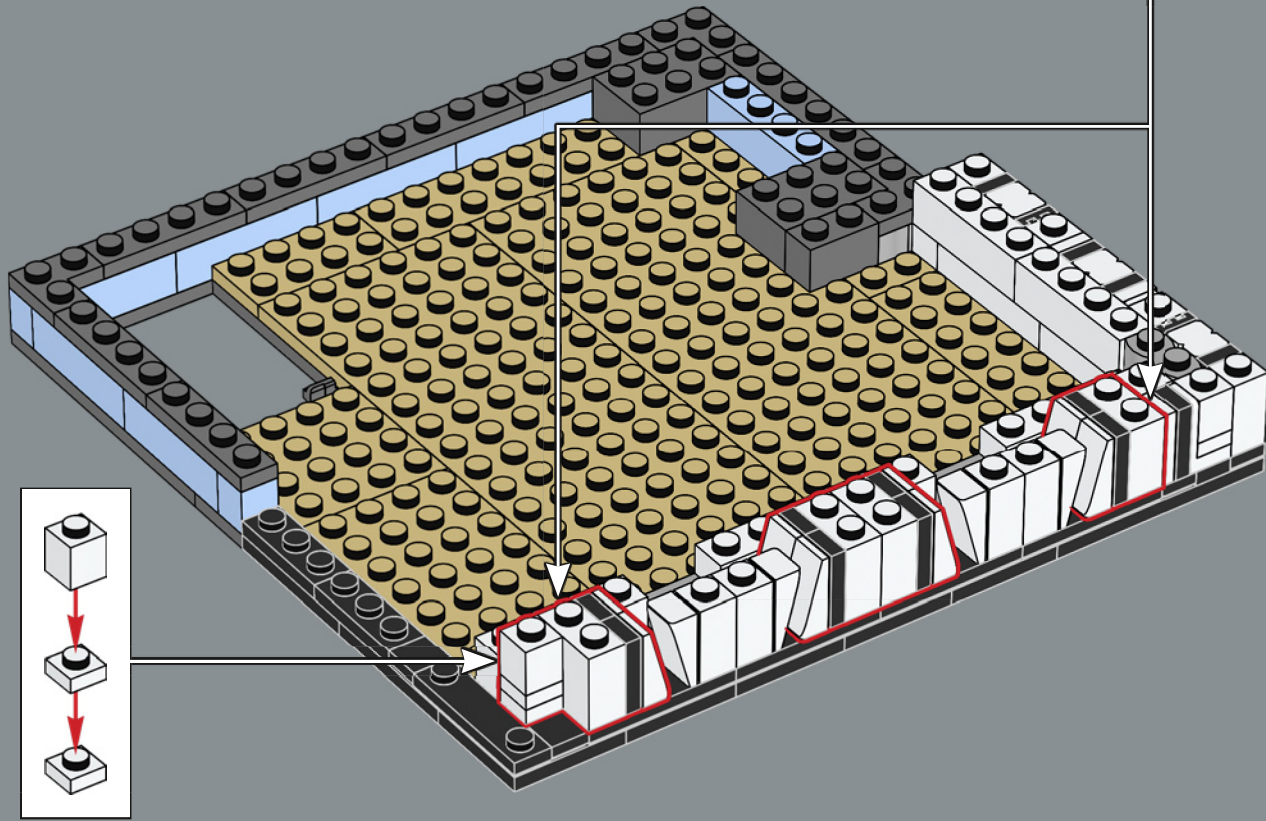
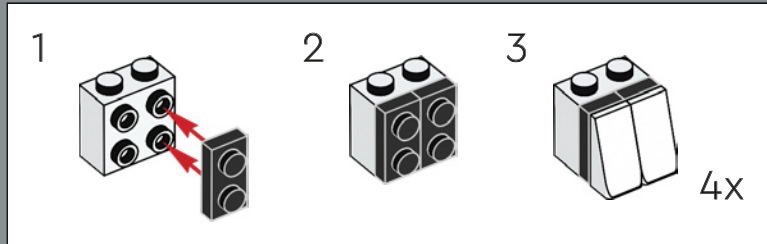



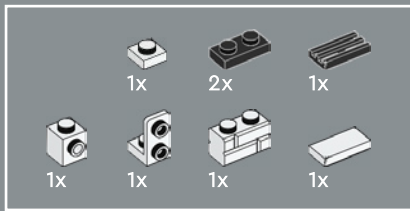

403

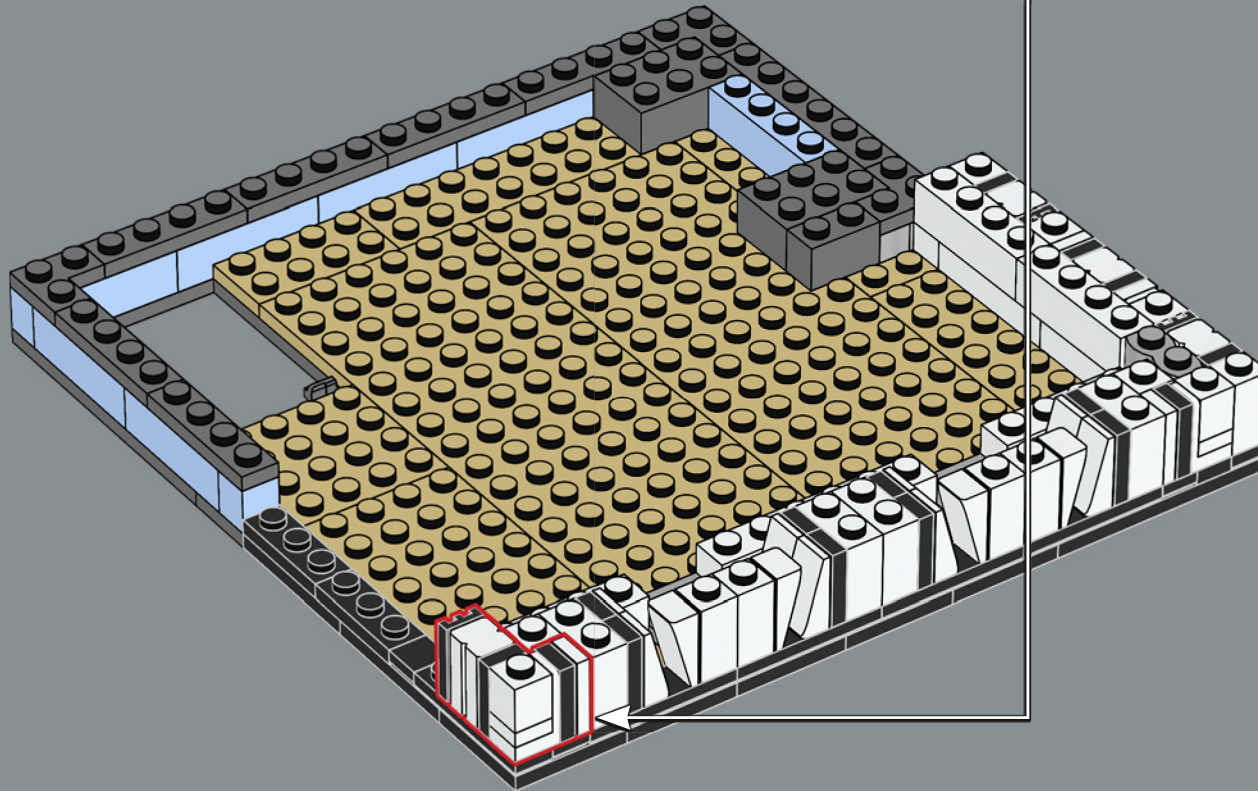
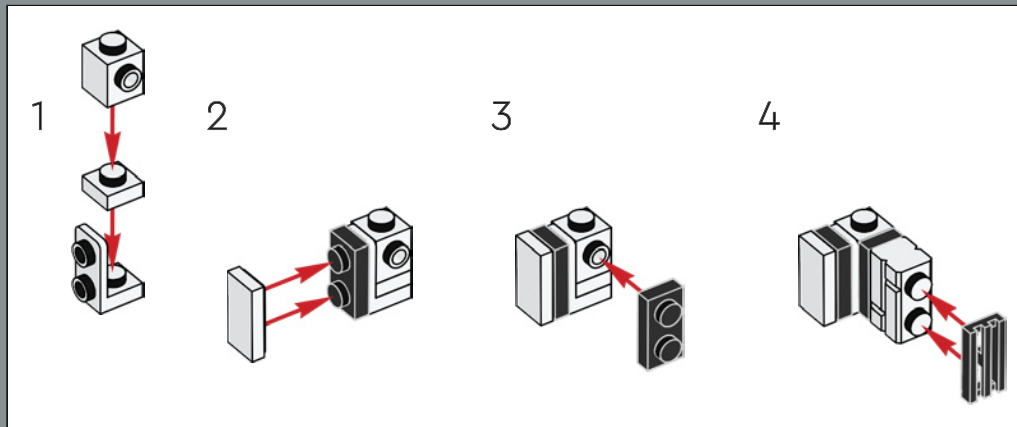

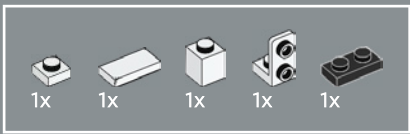

404

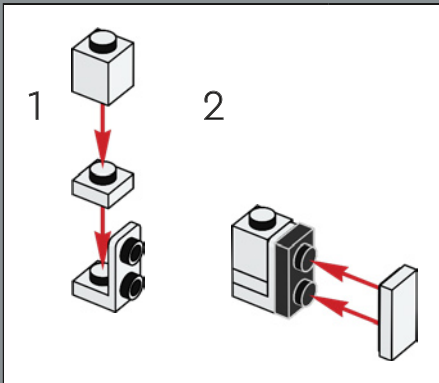
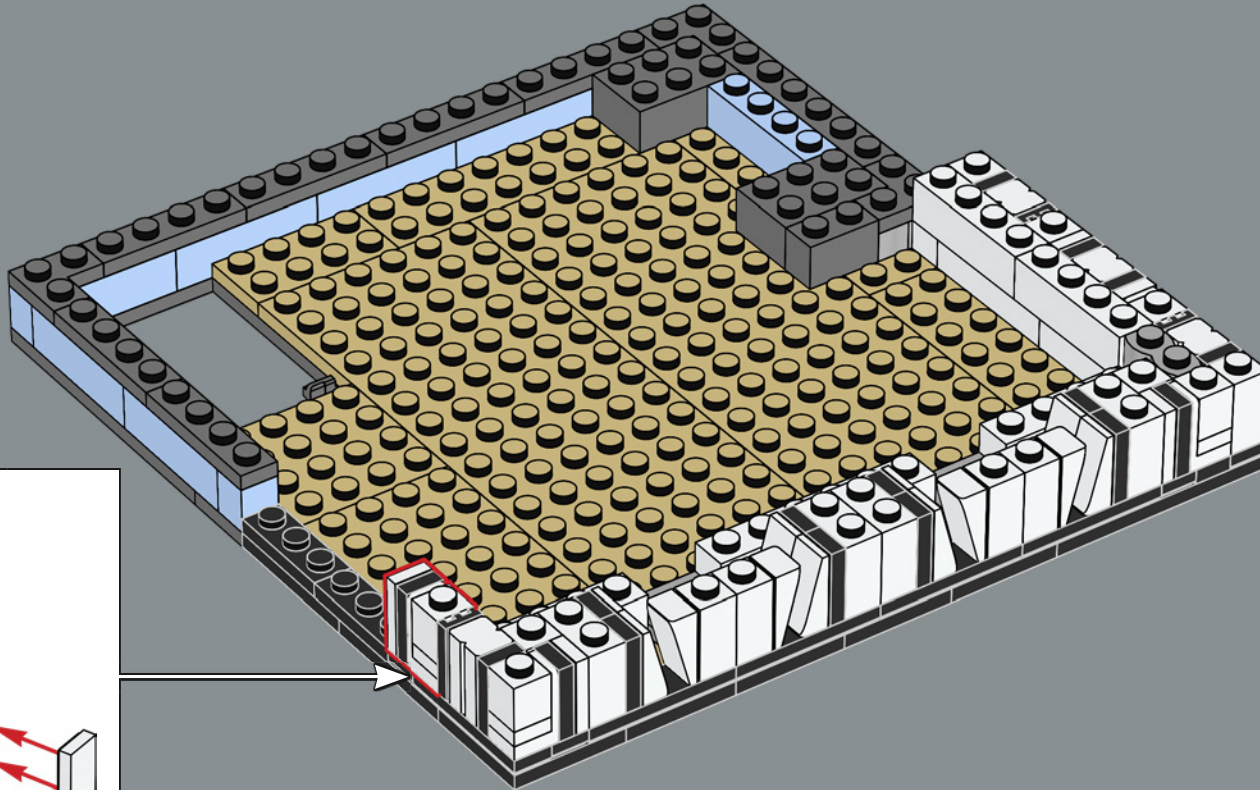

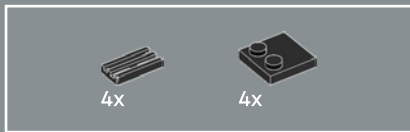

405

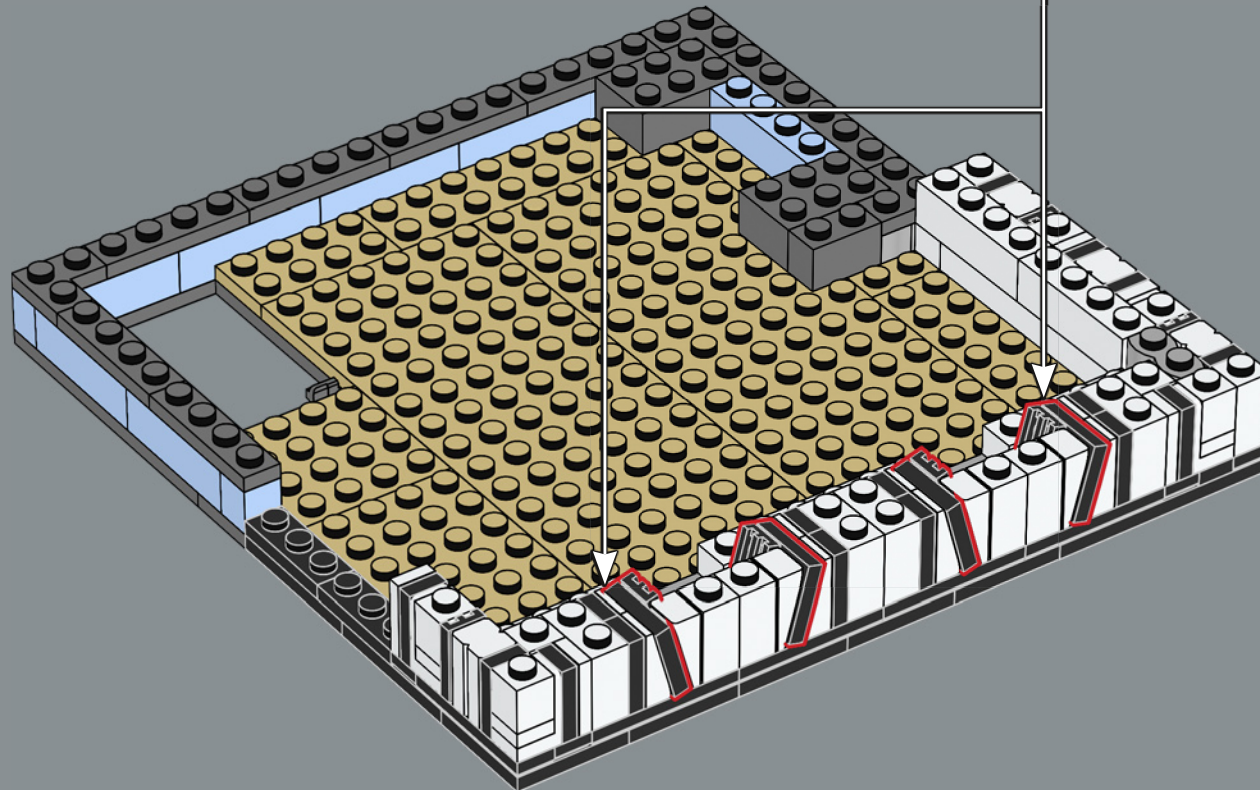
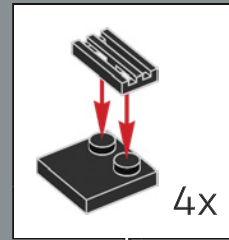

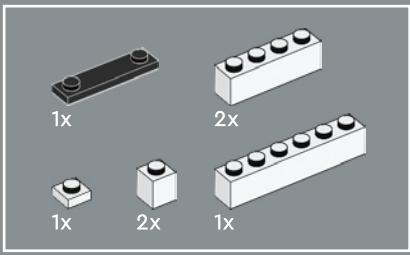

406

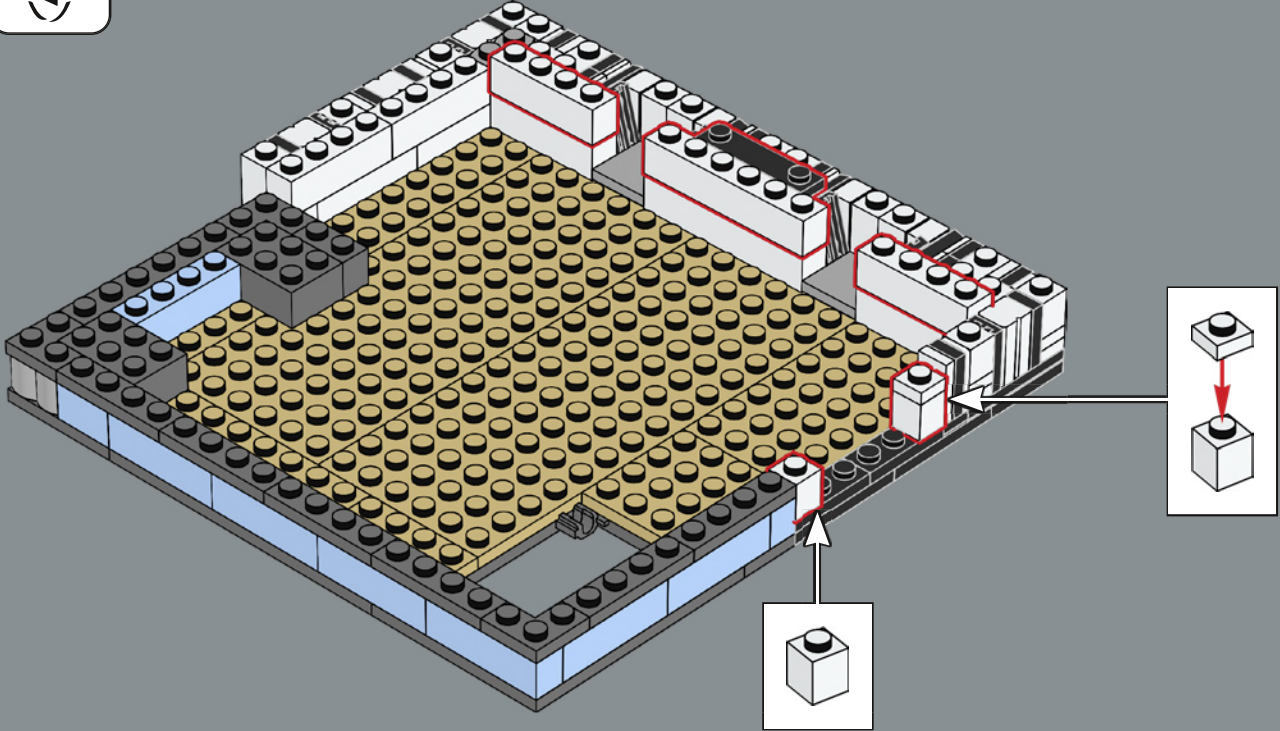

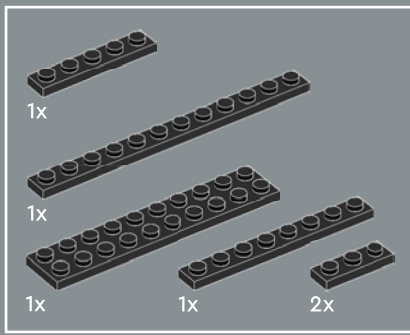

407

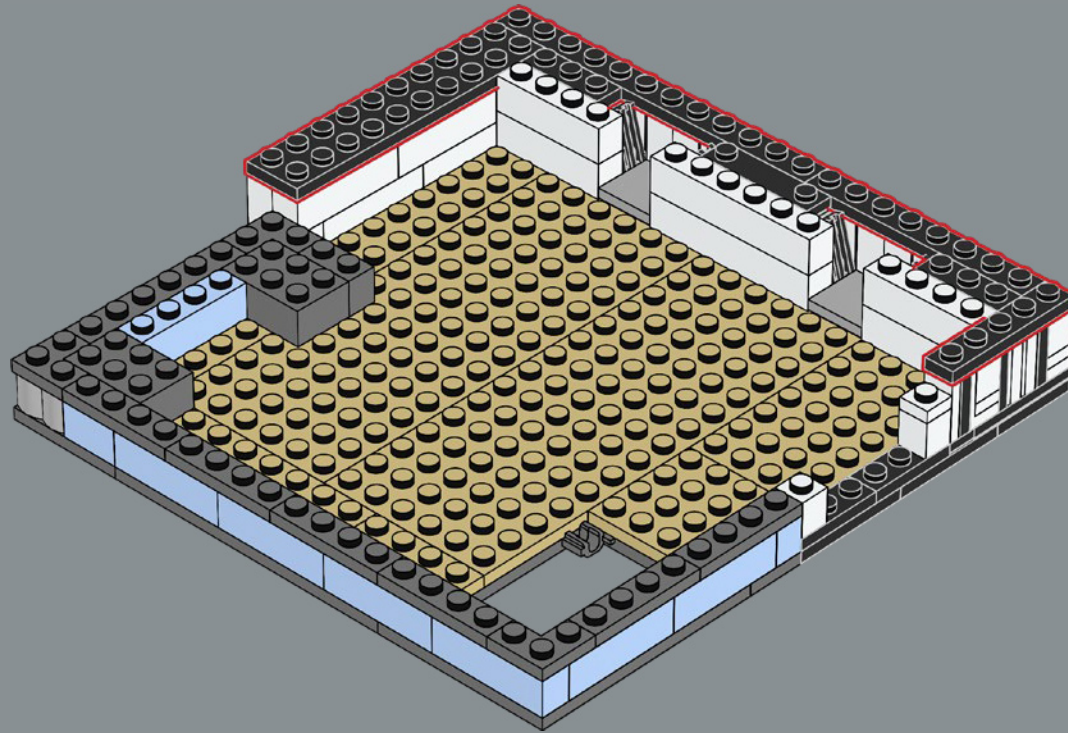

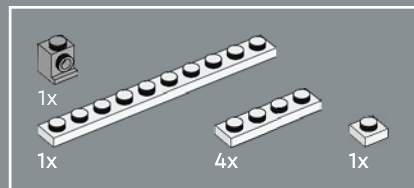

408

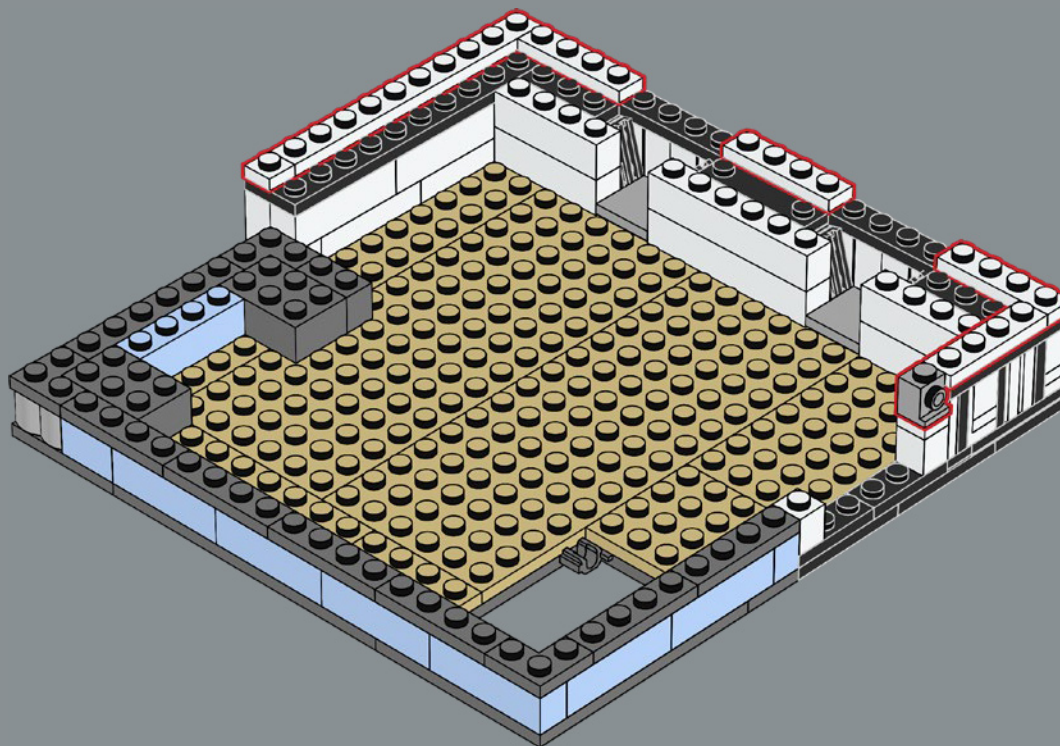

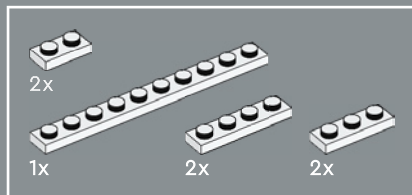

409

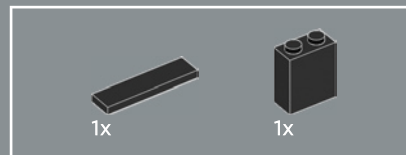
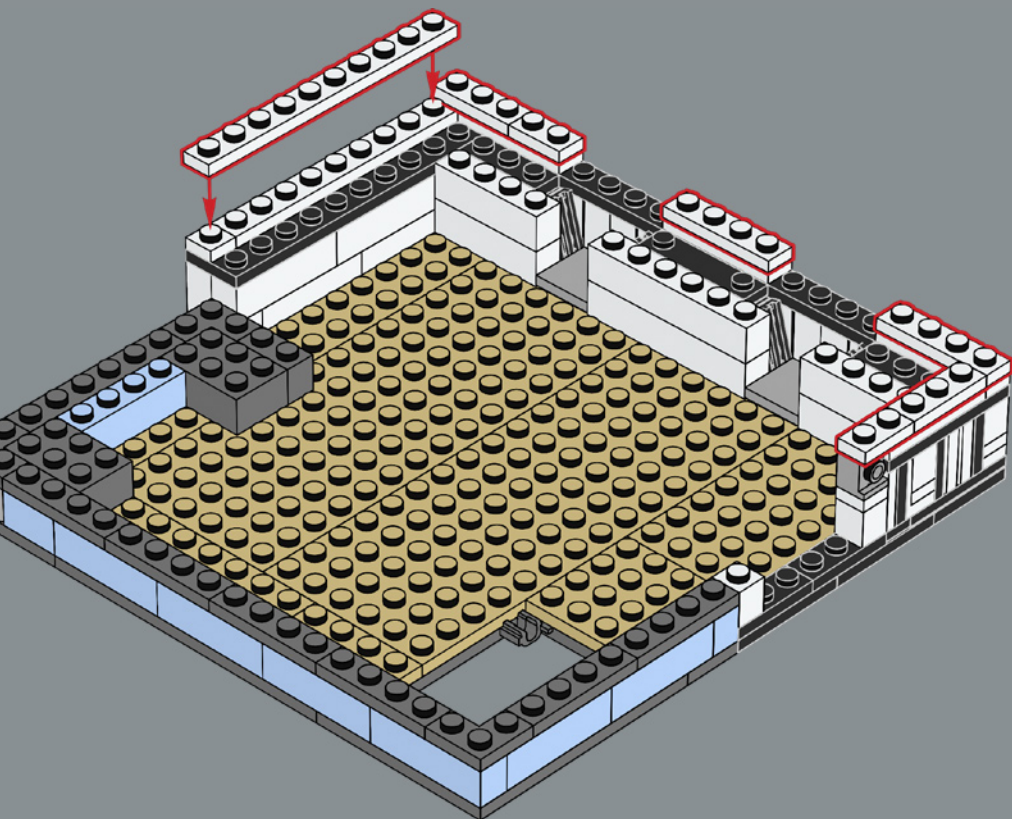

410

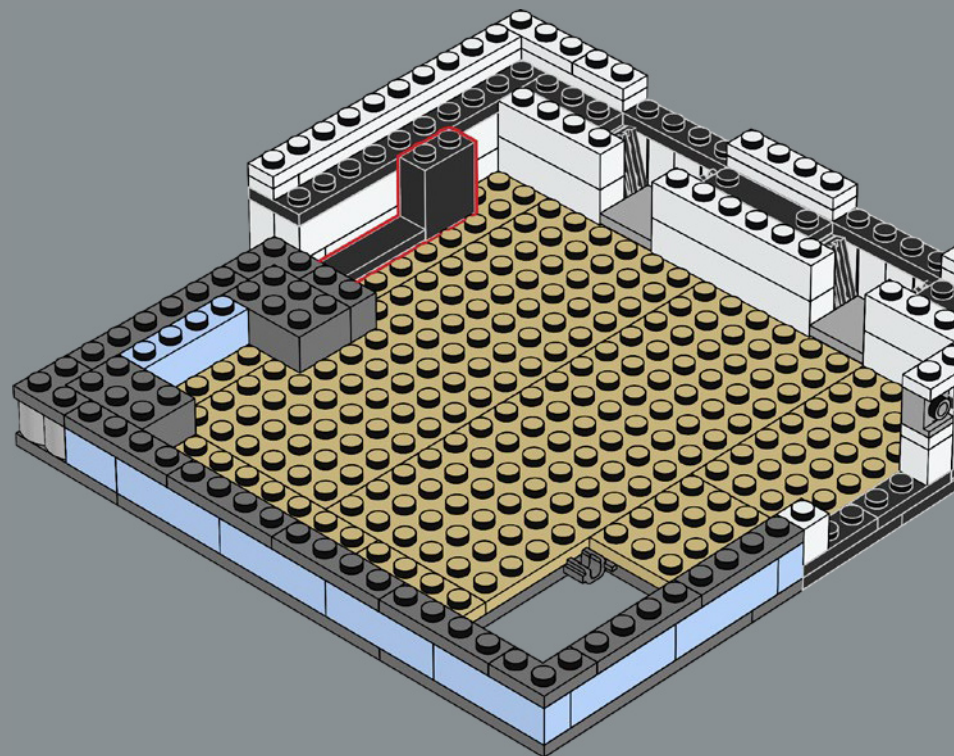

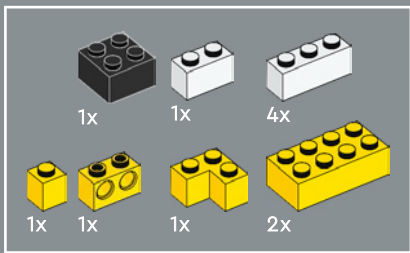

411

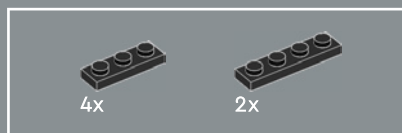
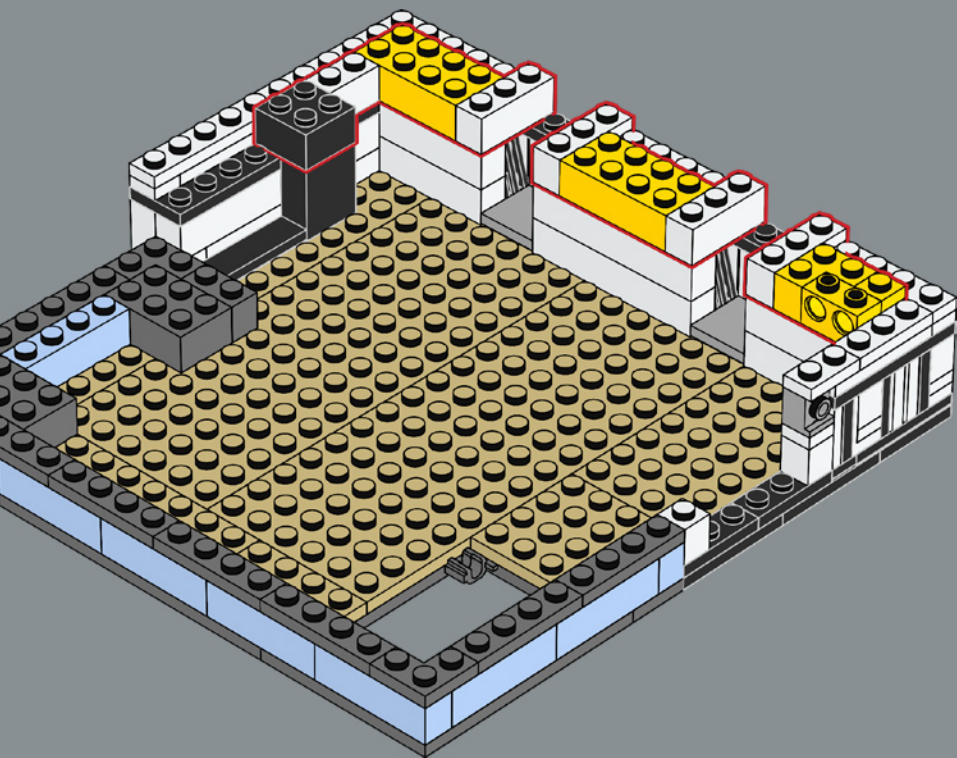

412

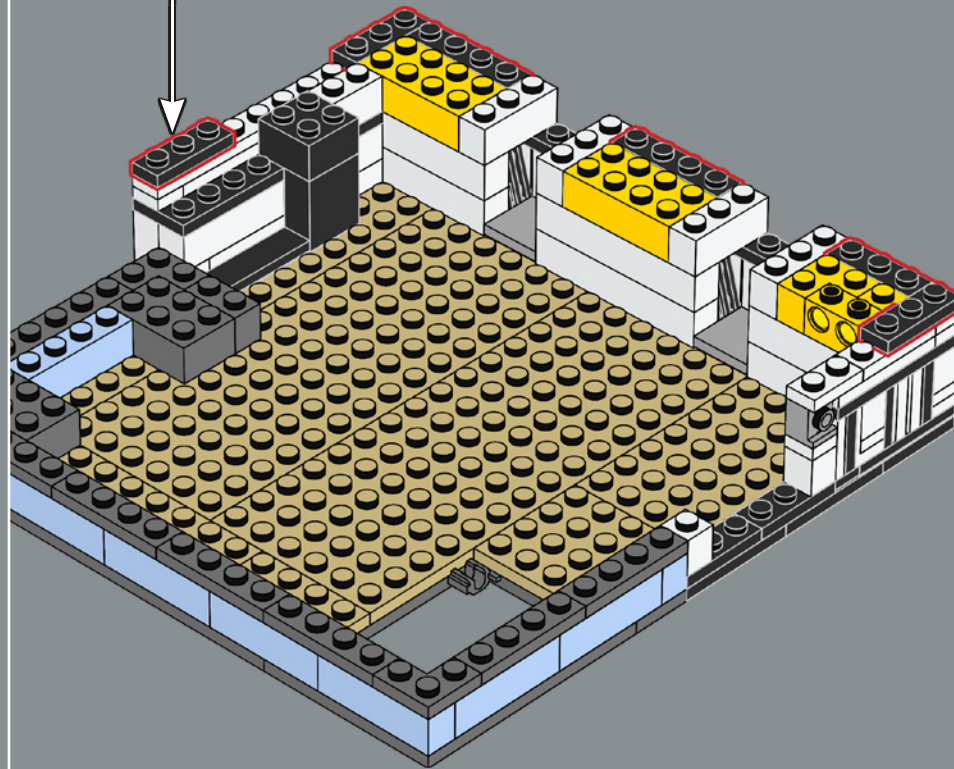
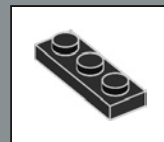



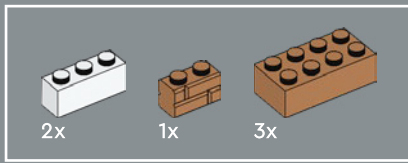

413

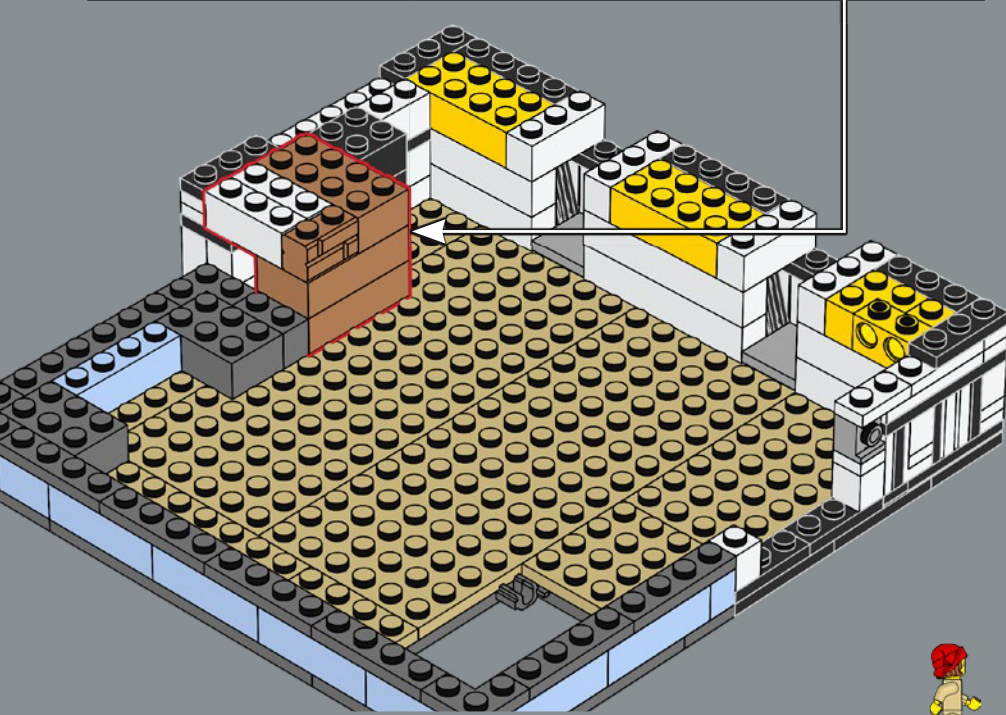
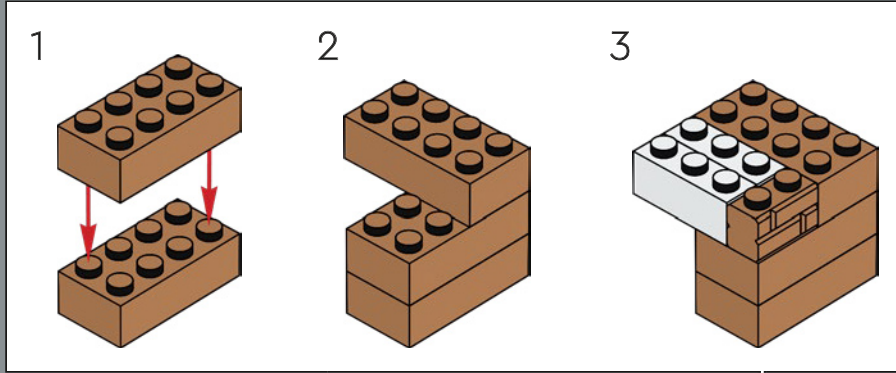

414

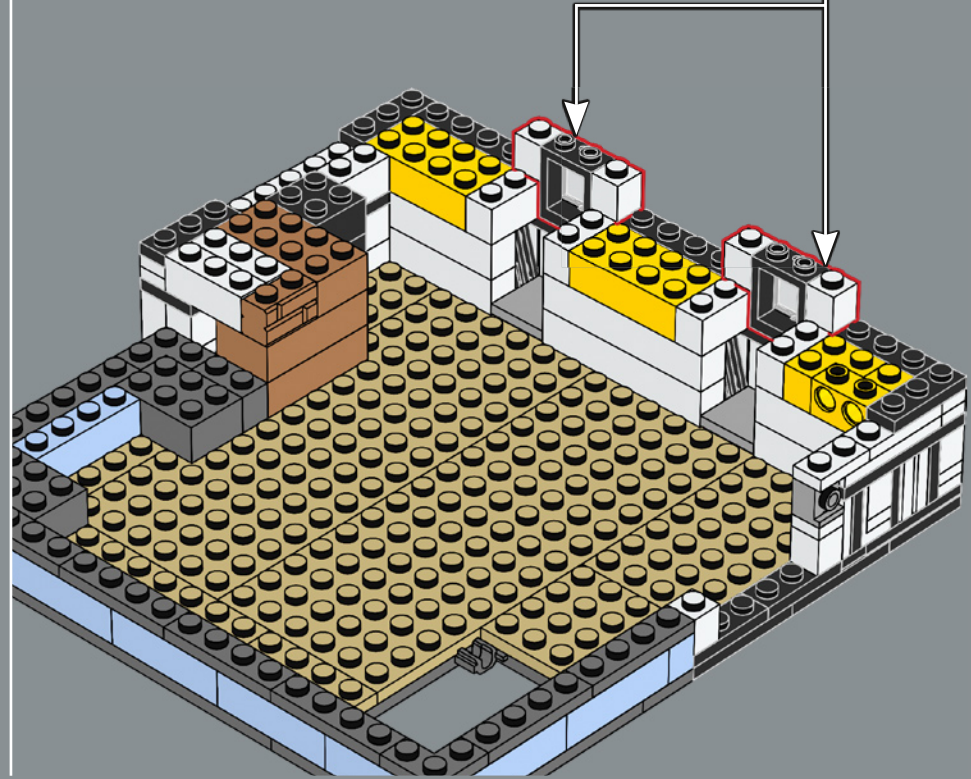
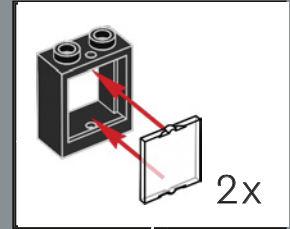

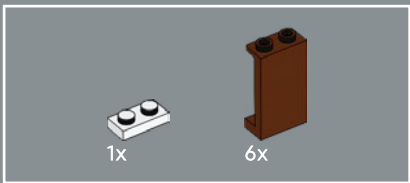

415

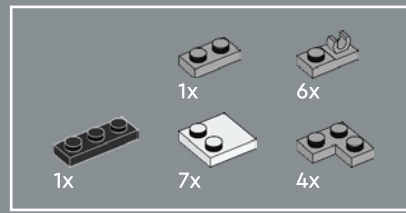
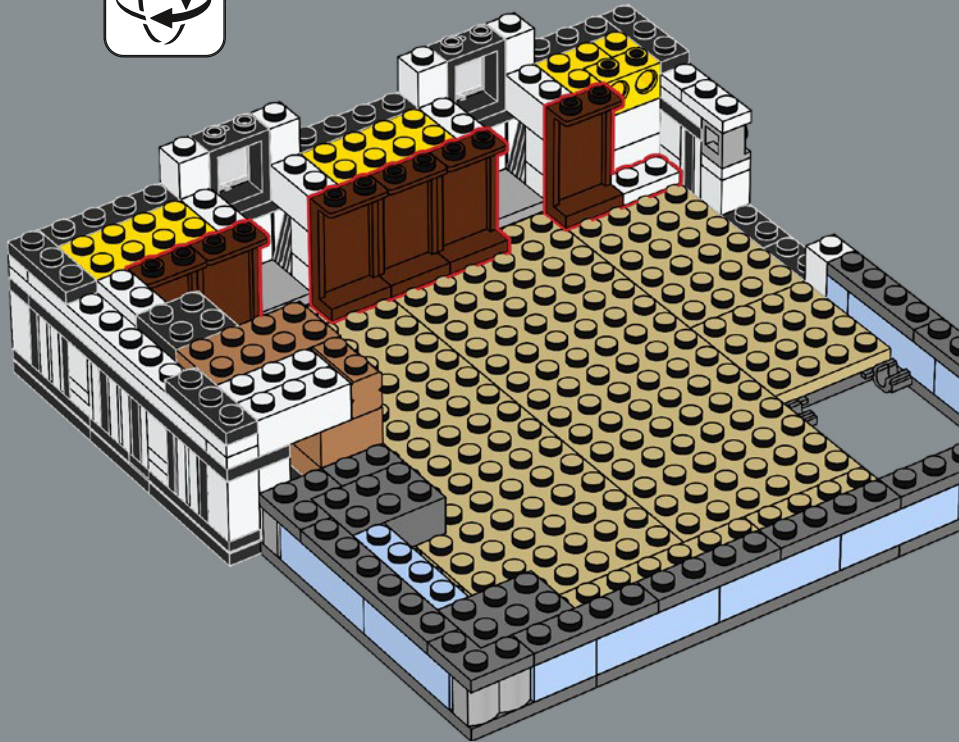

416

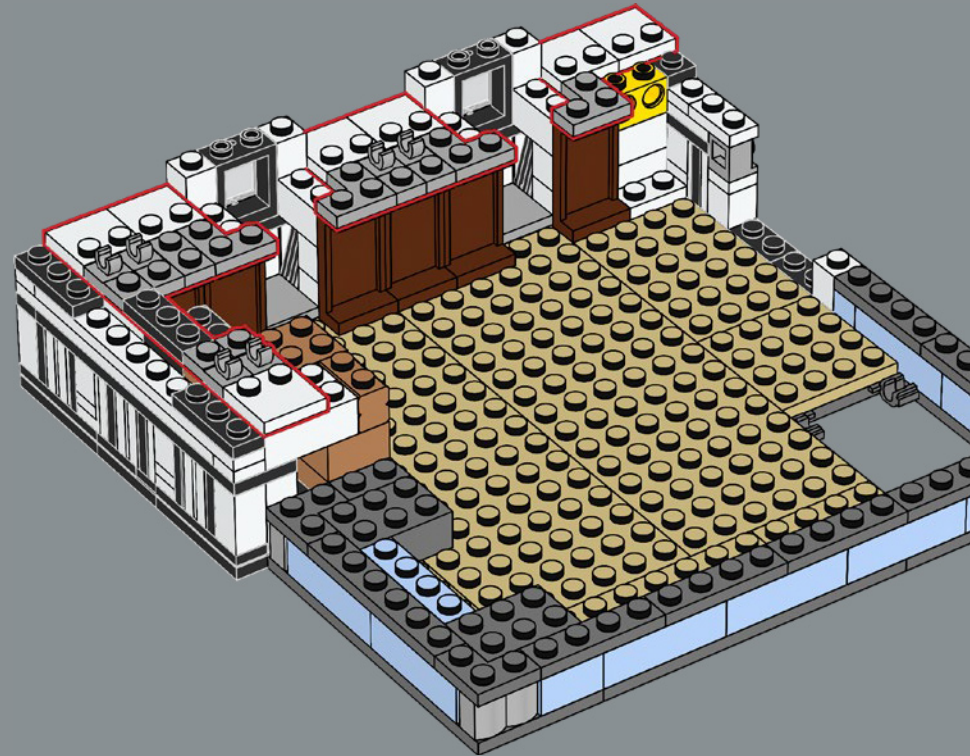

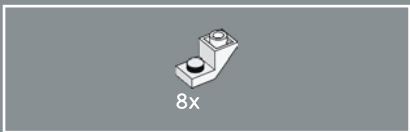

417

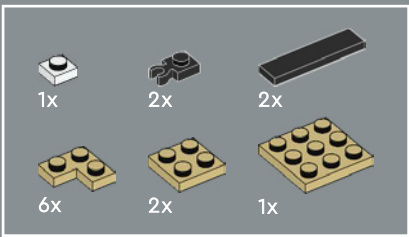
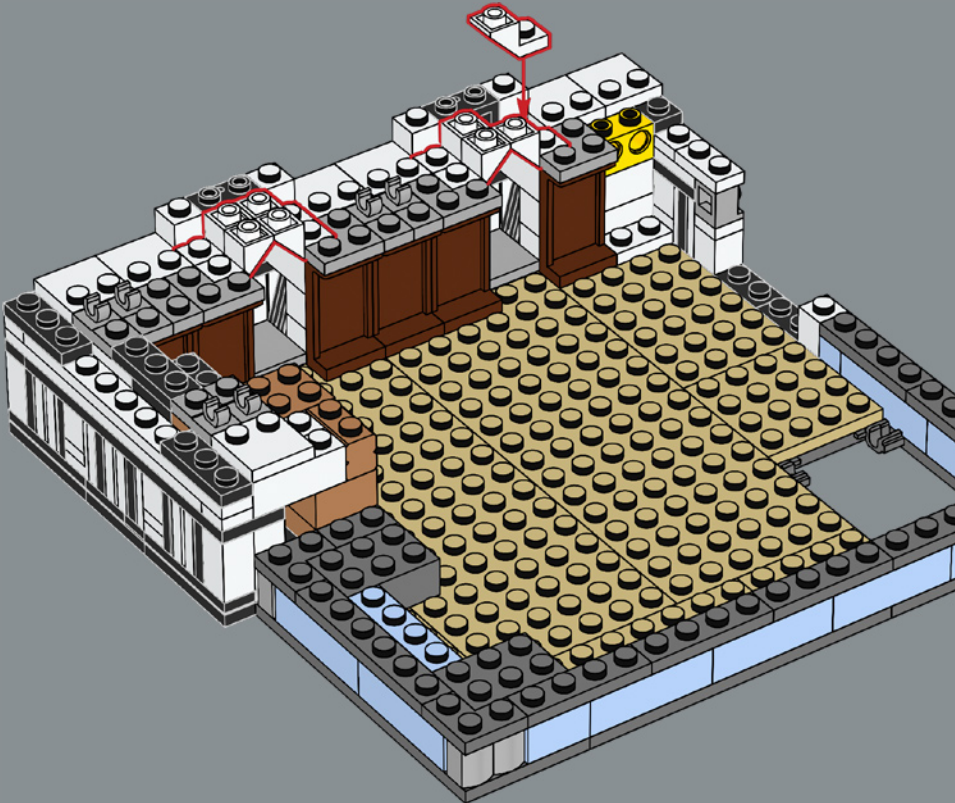

418

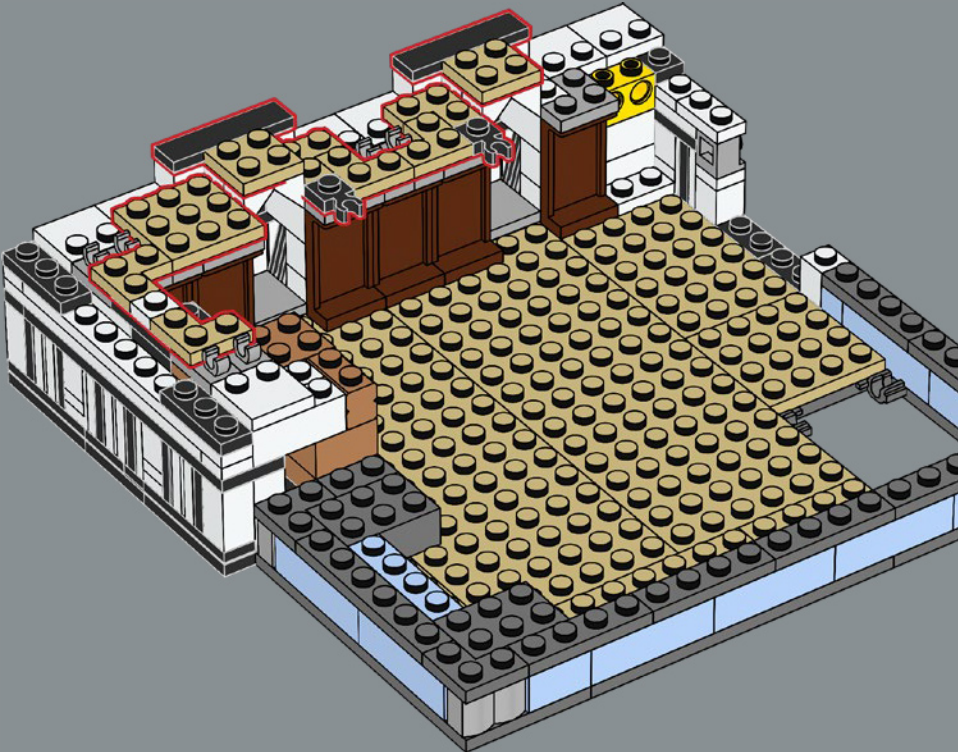



419

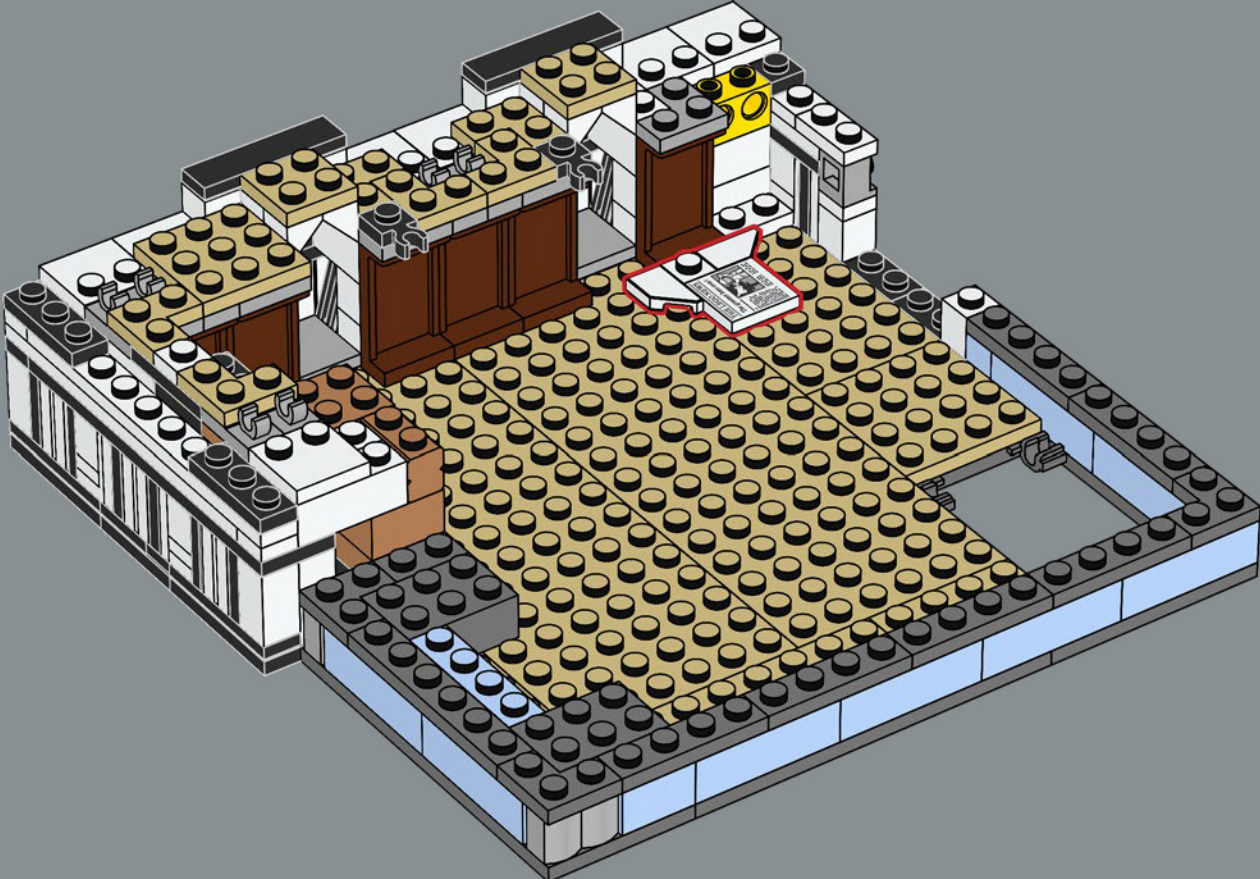

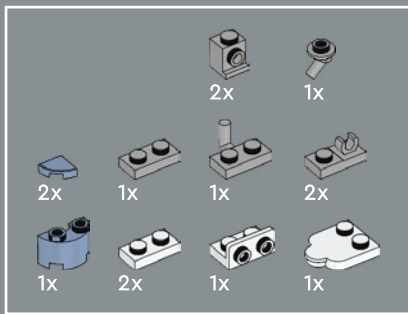

420

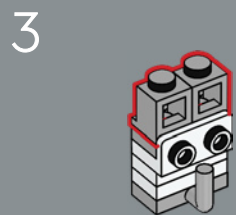
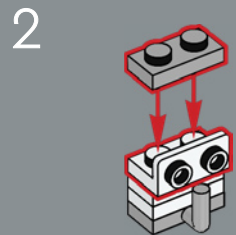
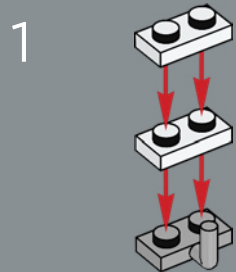

4

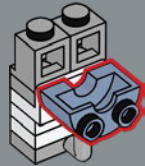

5

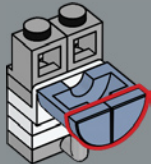

6

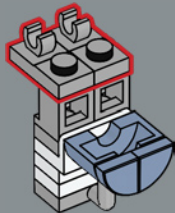

7

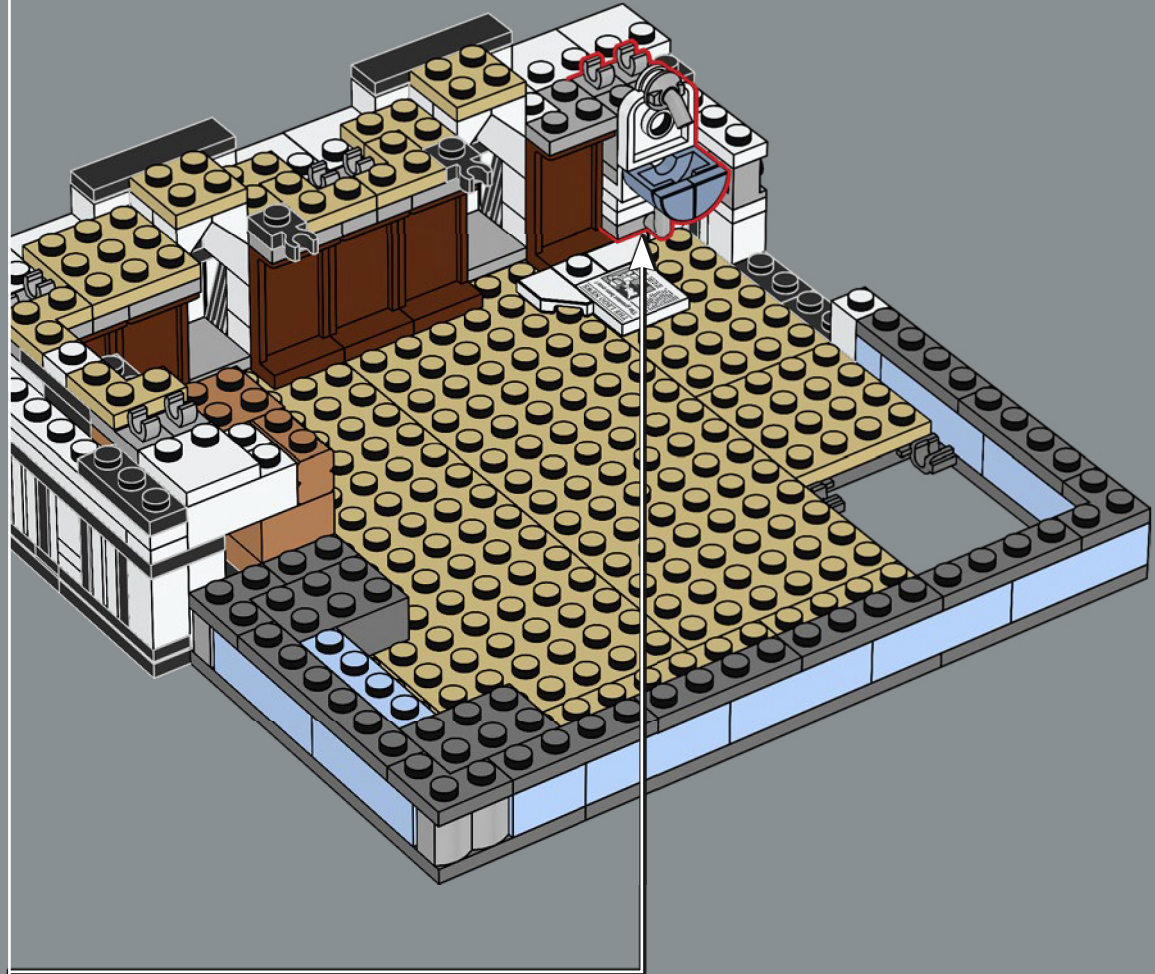
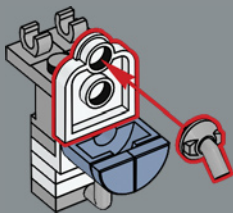

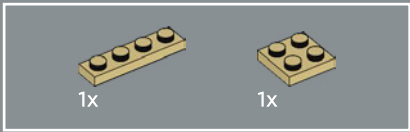

421

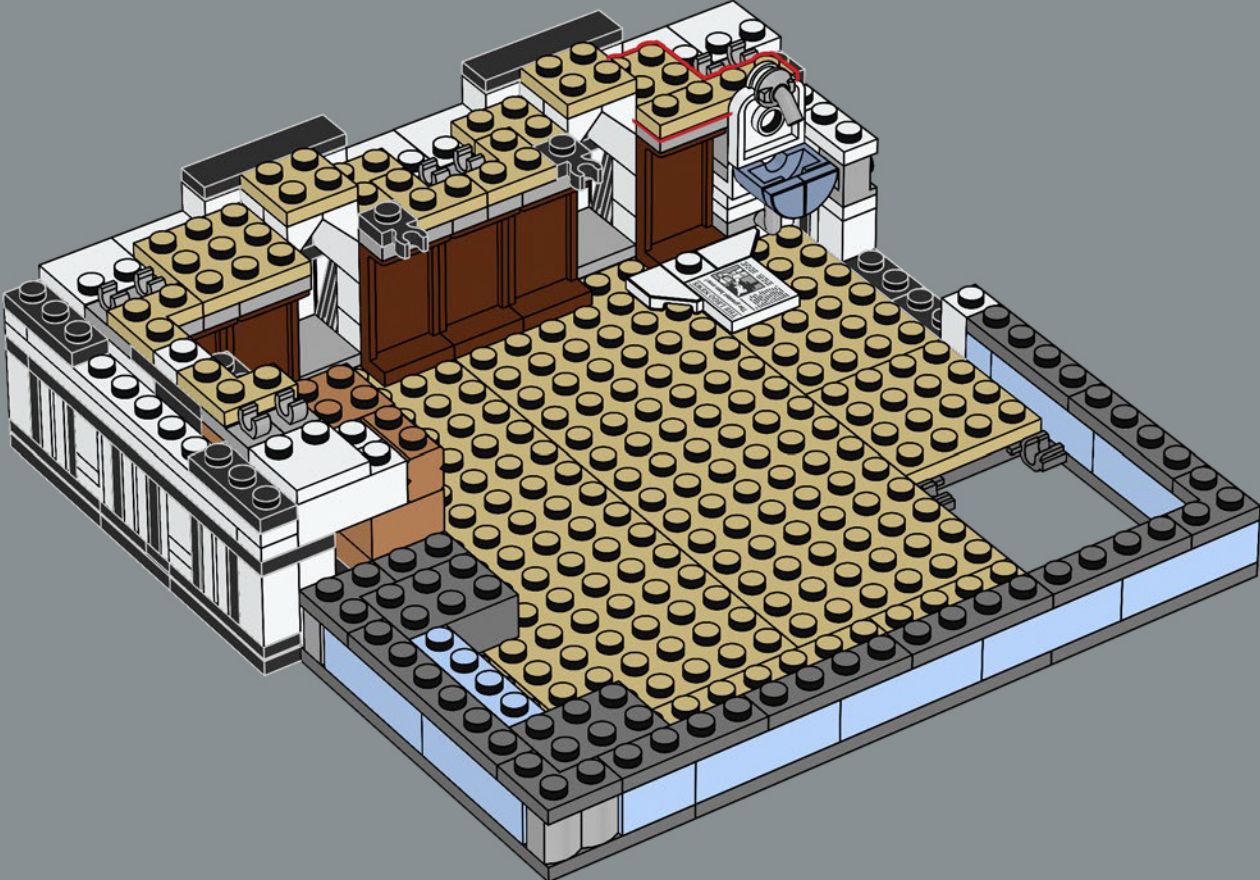

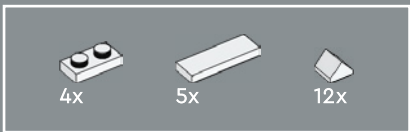

422

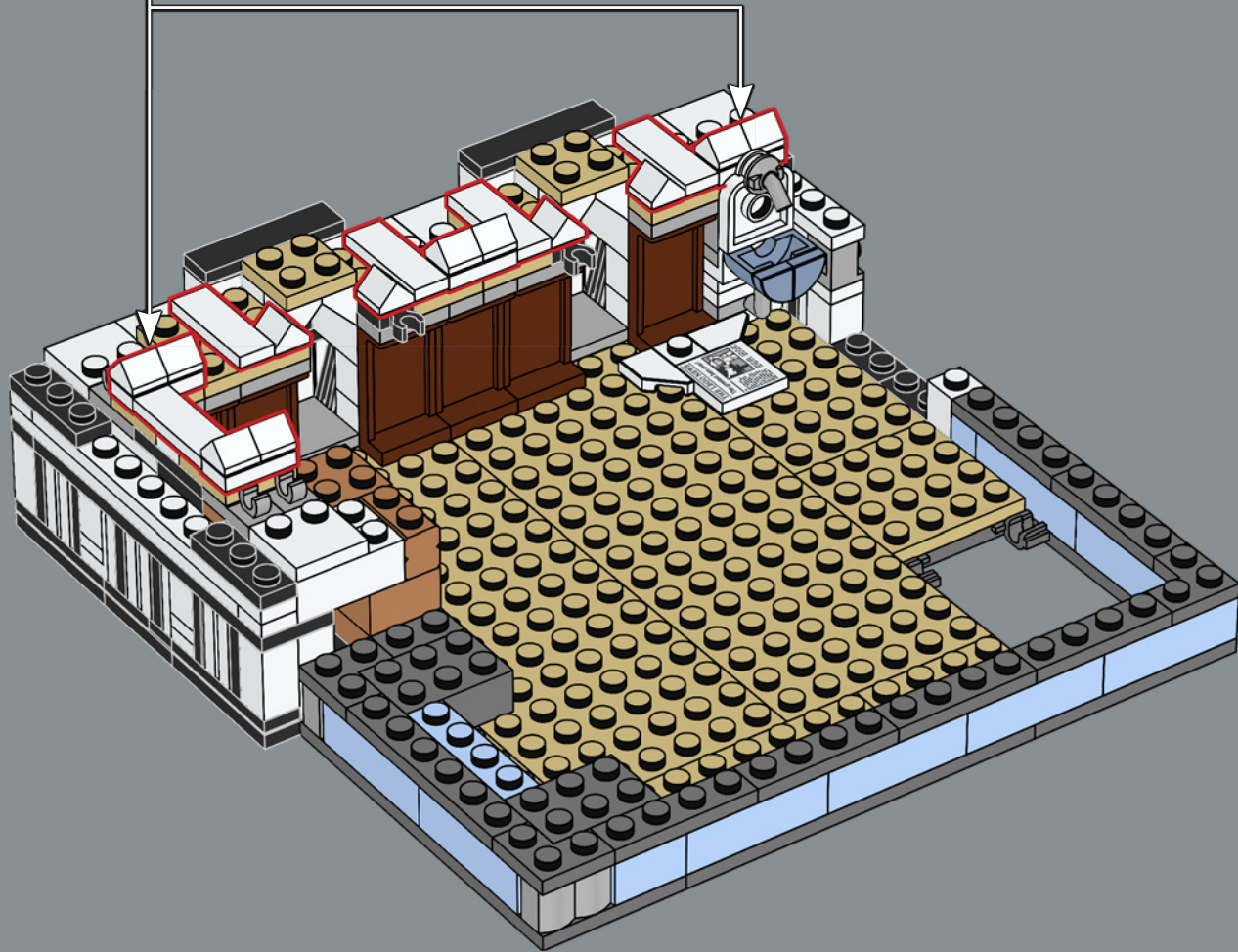
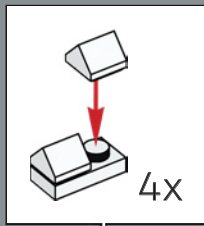

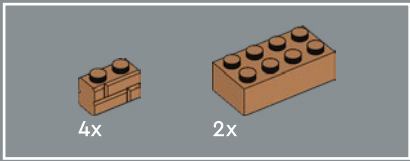

423

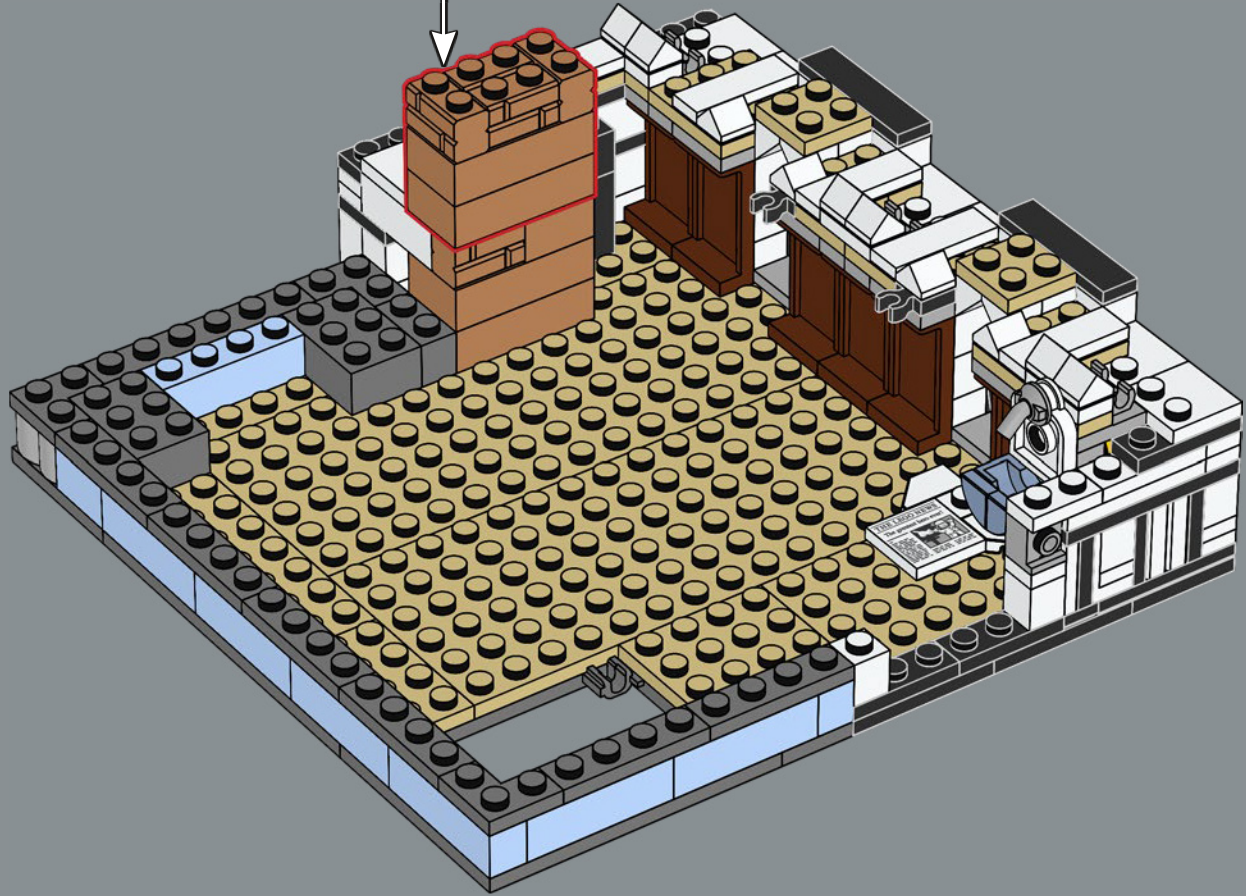
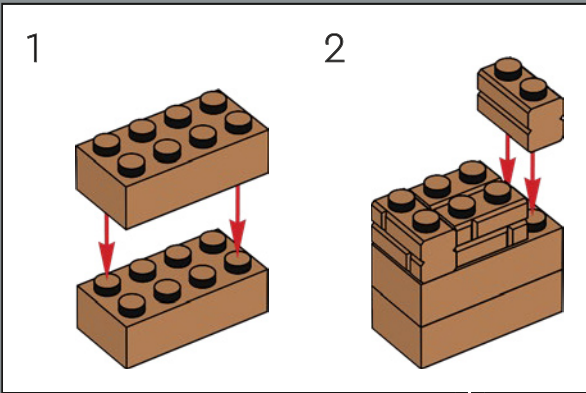





424

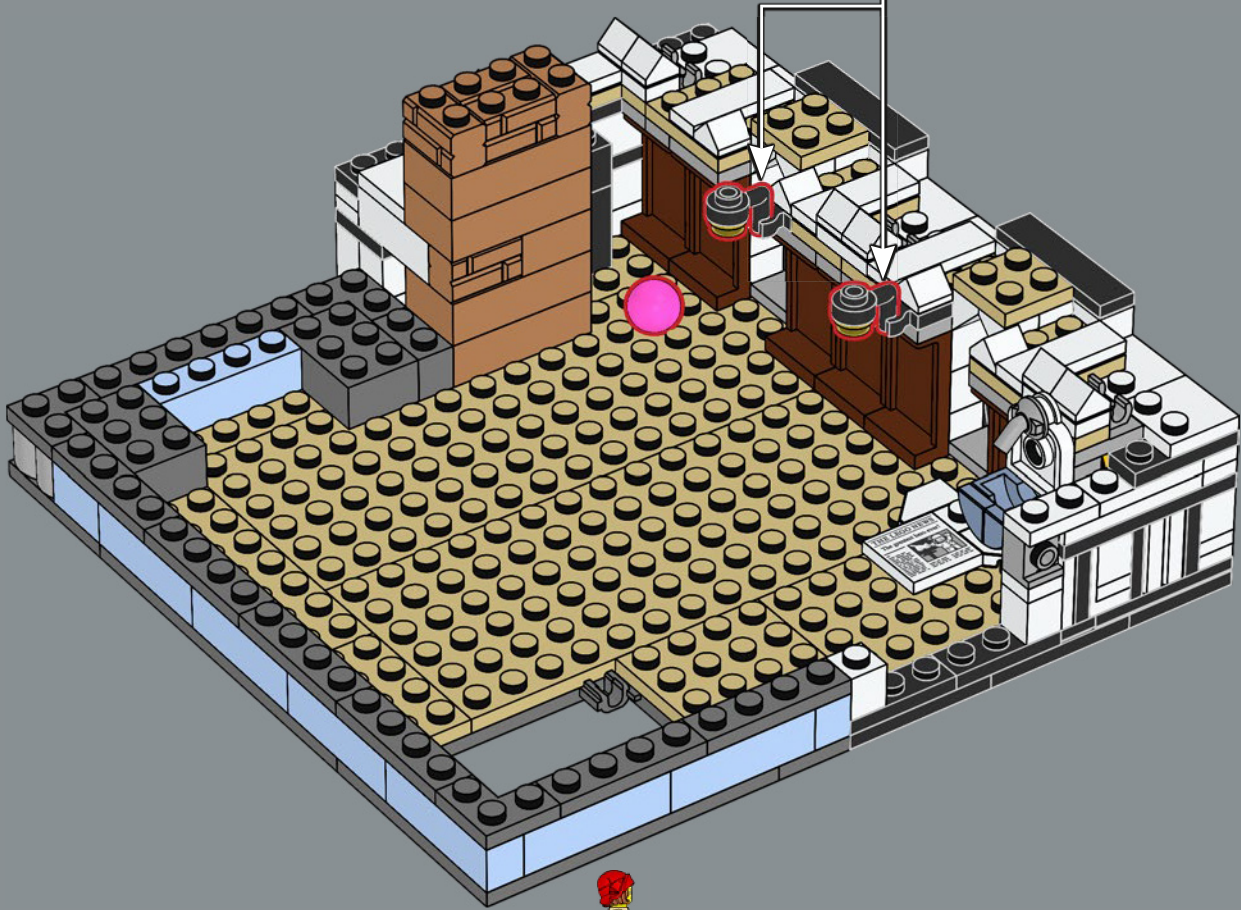

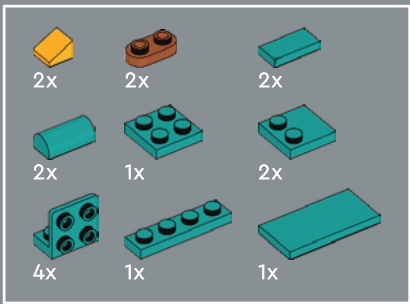

425

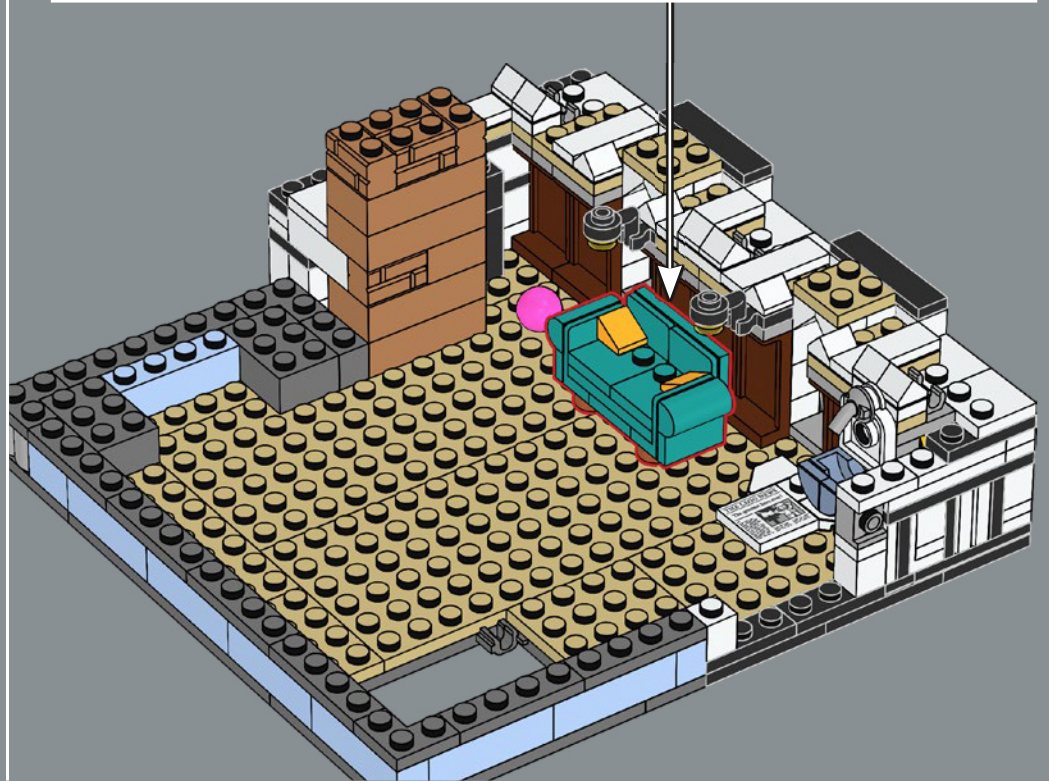
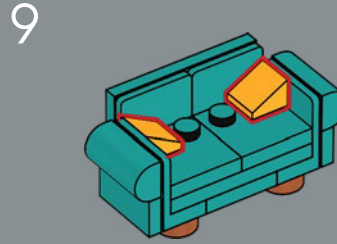
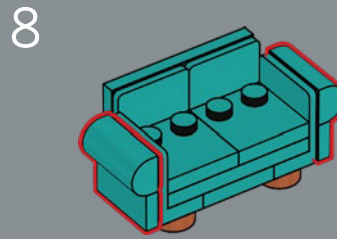
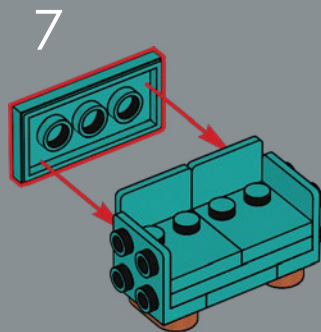
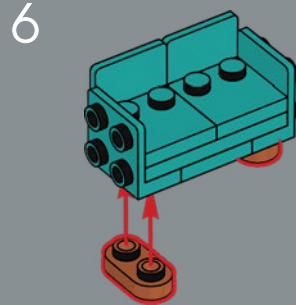
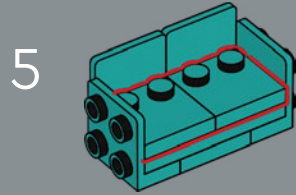
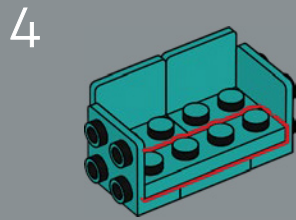
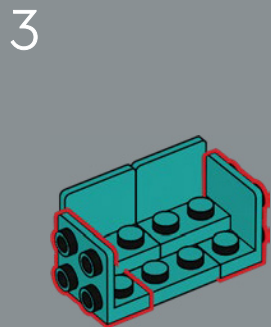
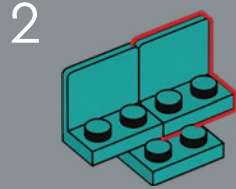
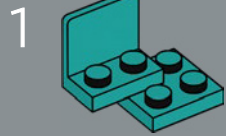

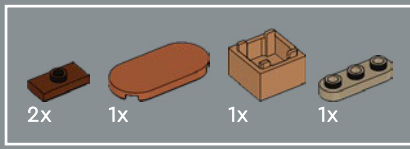

426

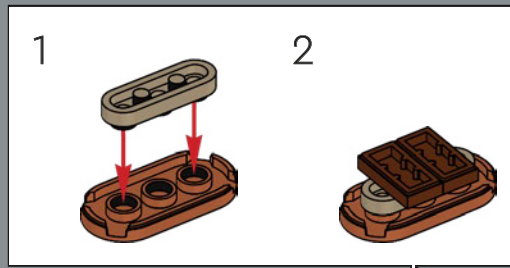

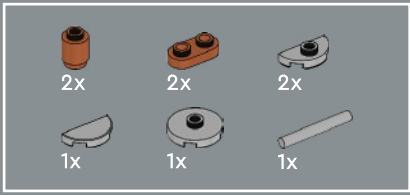

427

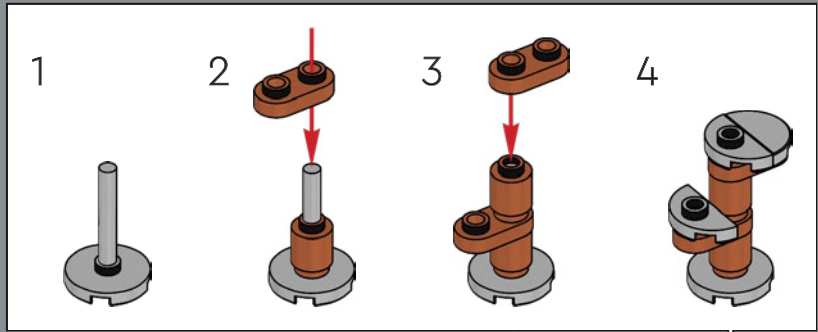

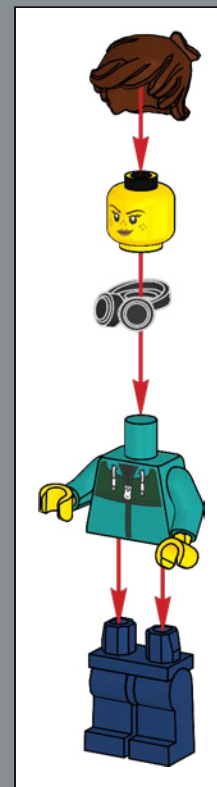

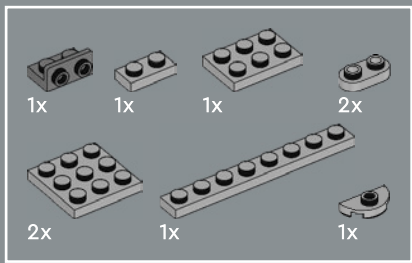

428

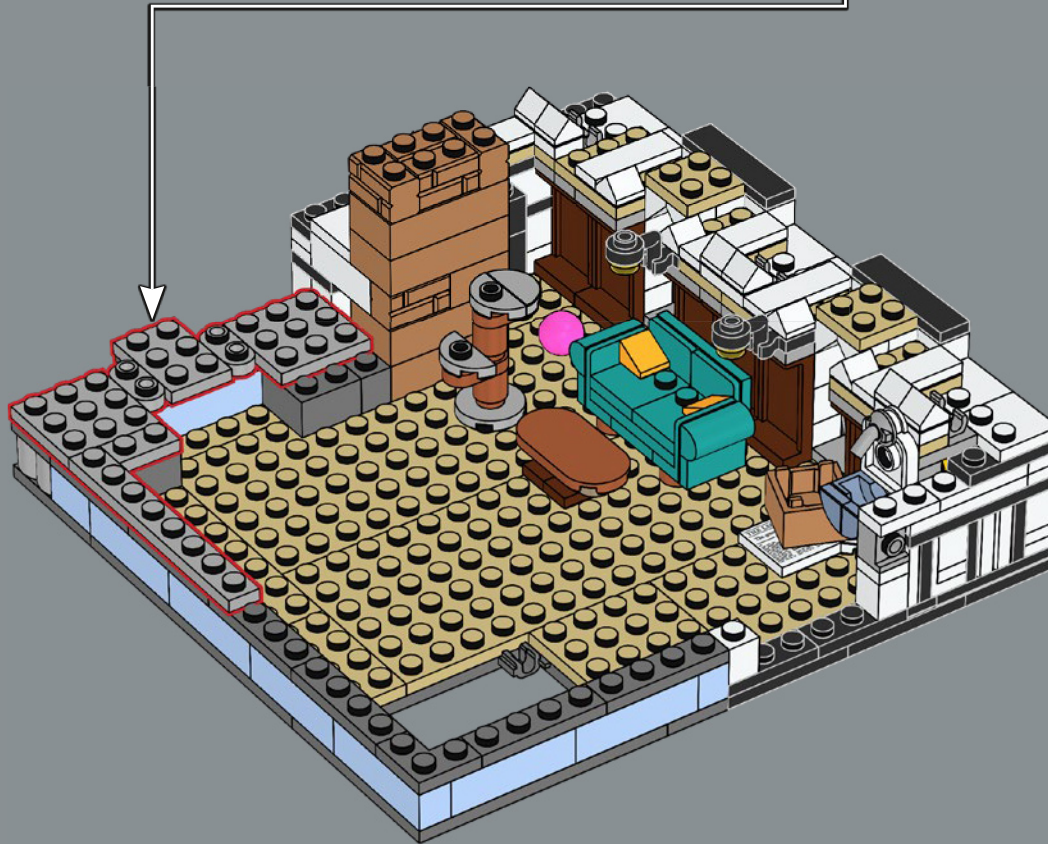
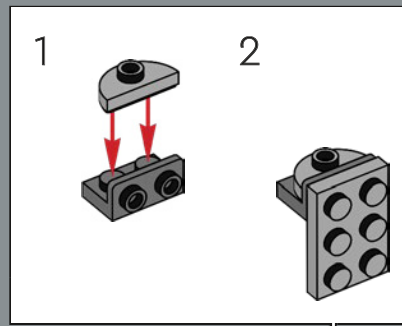

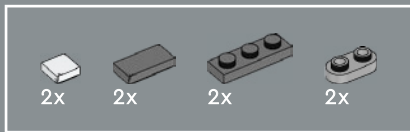

429

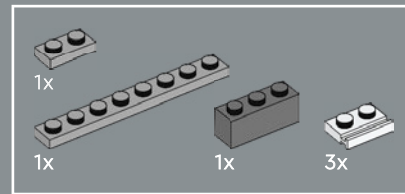

430

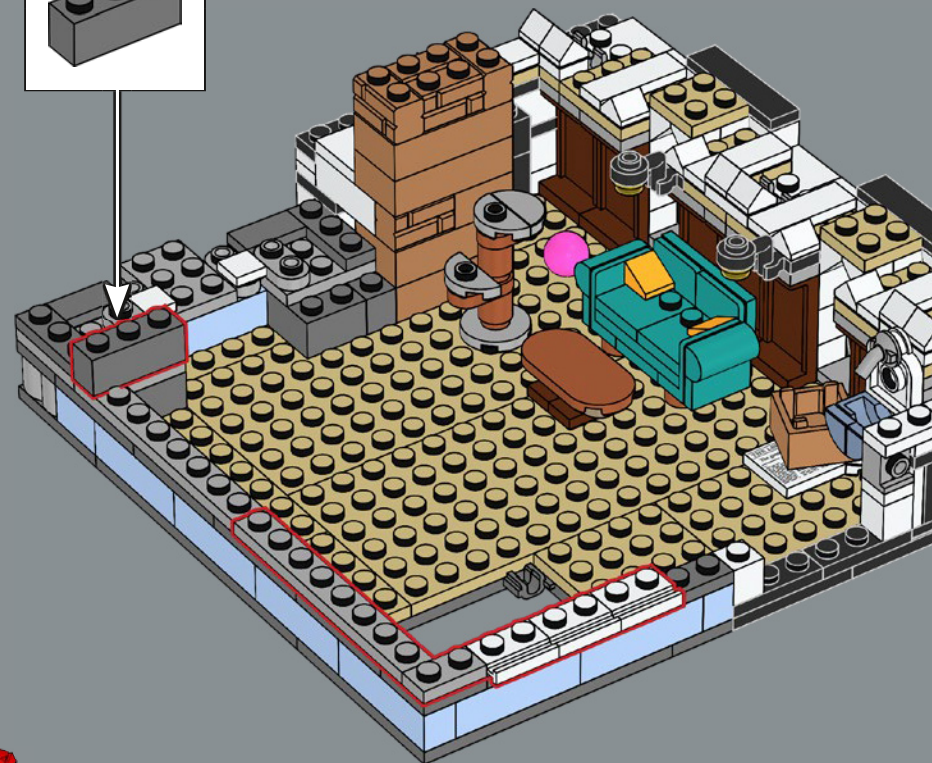
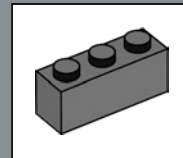

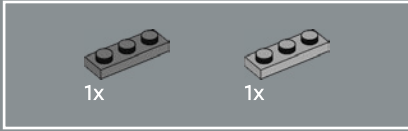

431

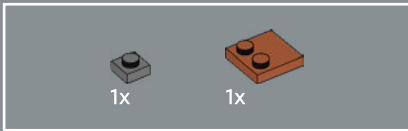
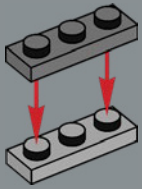

432

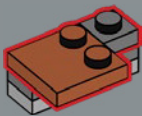

433

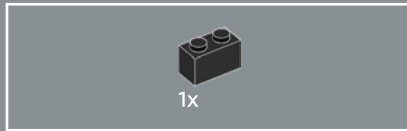
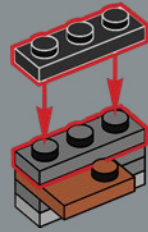

434

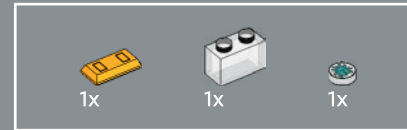
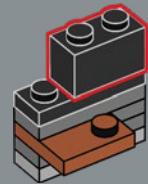

435

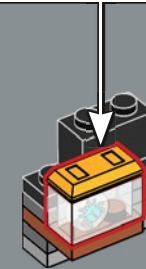
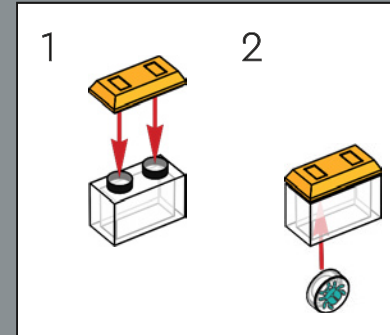



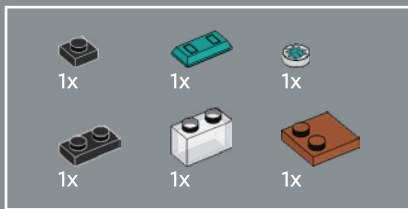

436

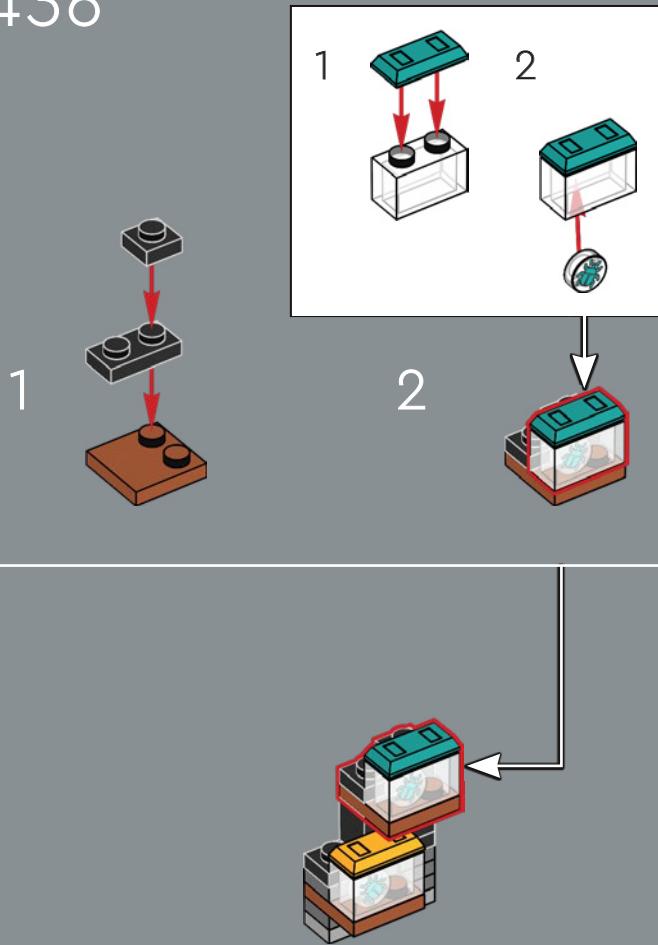

The tenant's collection of insects is very valuable. This is why she will never let her friend's chameleon, who lives next to the bookshop, come over.

La collection d'insectes de la locataire est d'une valeur inestimable. C'est pourquoi elle ne laisse jamais venir le caméléon de son amie, qui habite à côté de la librairie.

La colección de insectos de esta inquilina es muy valiosa. Por eso nunca permite que su amiga, que vive al lado de la librería, la visite con su camaleón.

437

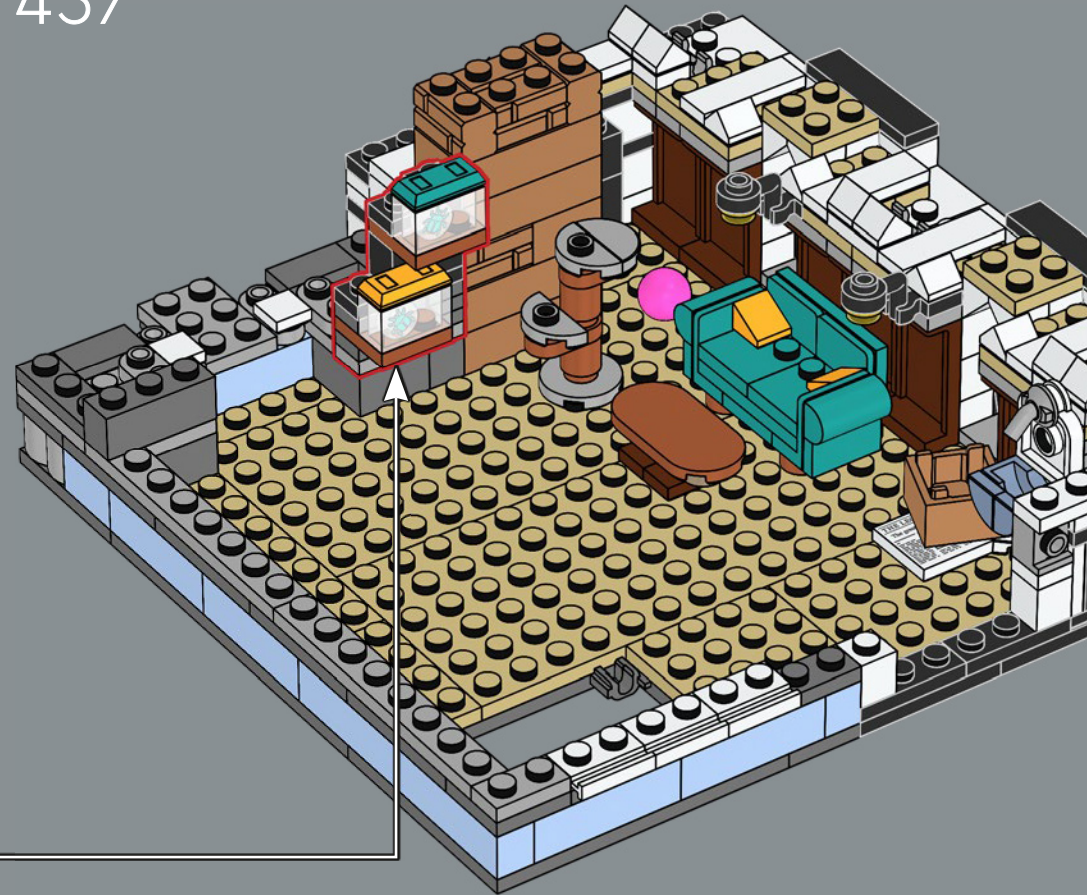

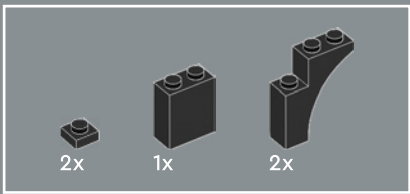

438

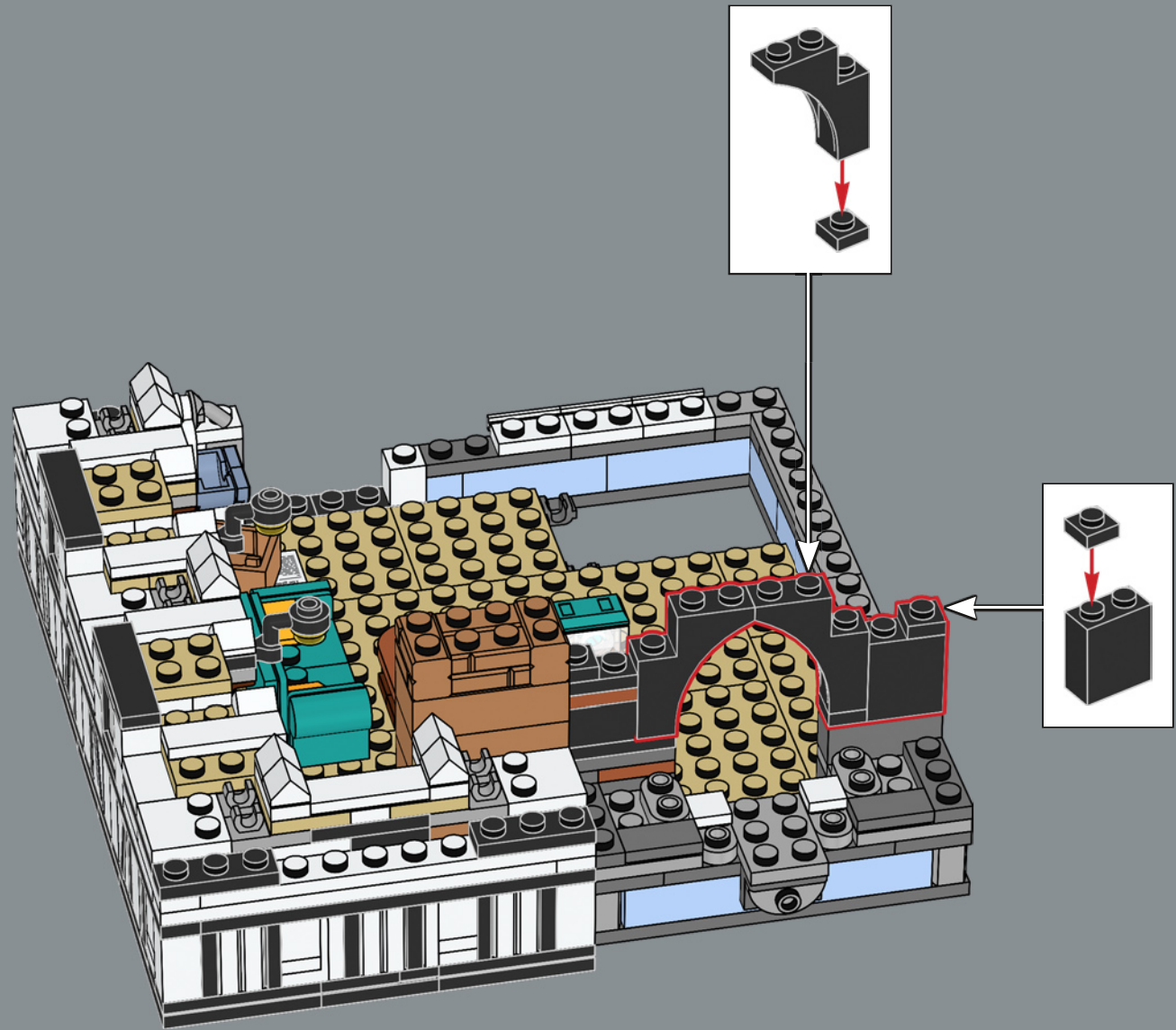

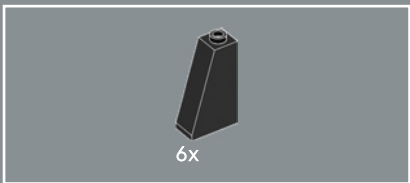

439

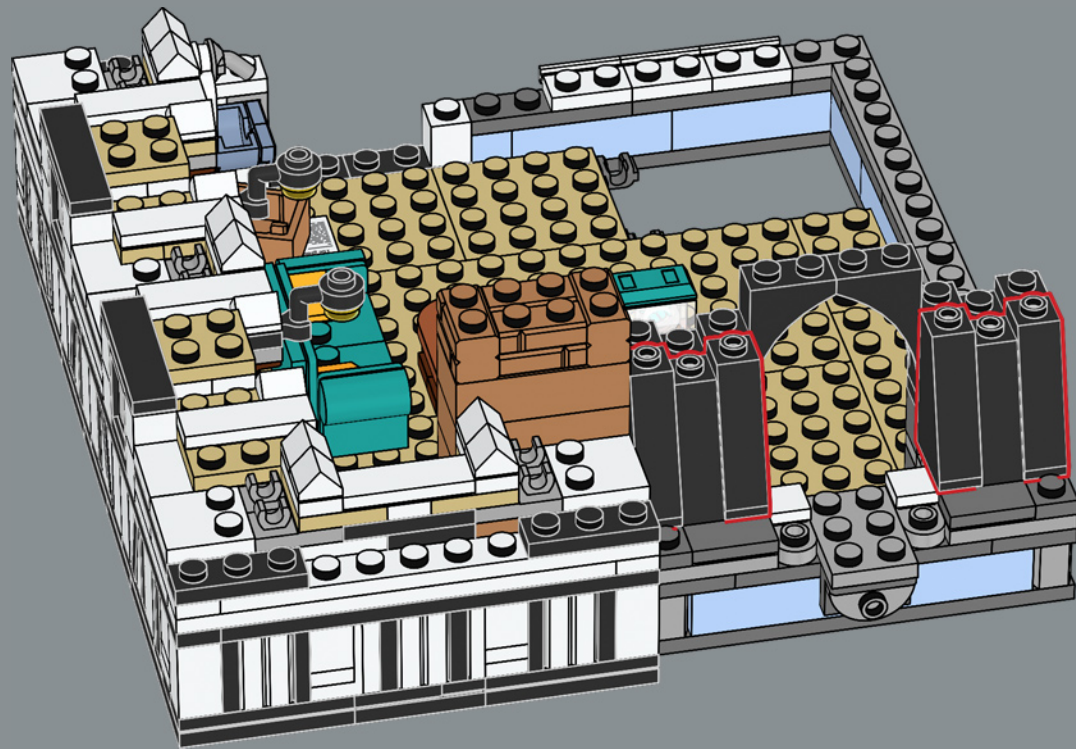

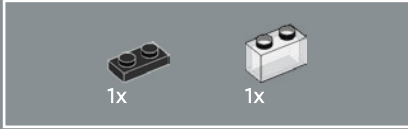
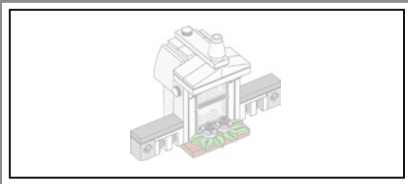

440

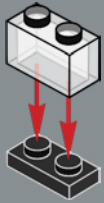

441

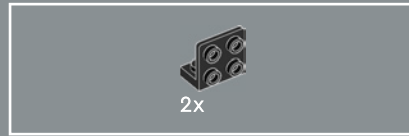
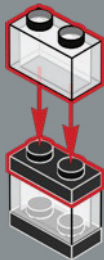

442

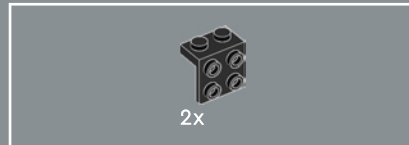
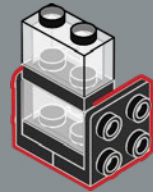

443

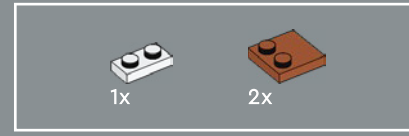
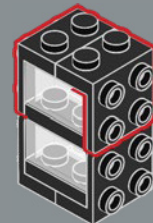

444

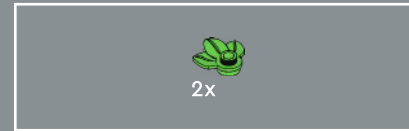
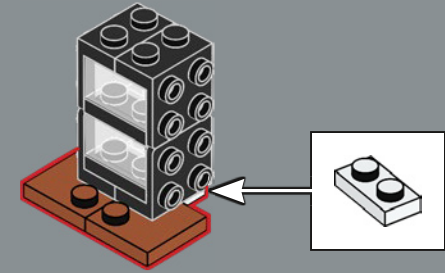

445





446

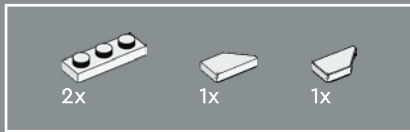

447

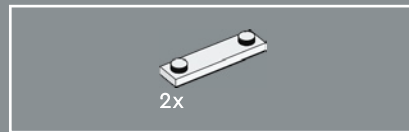

448

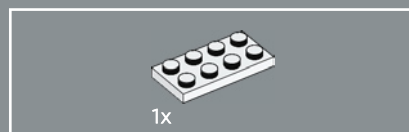
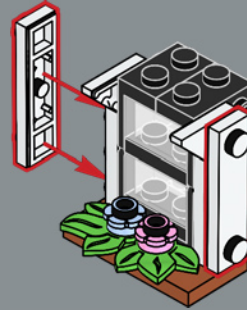

449

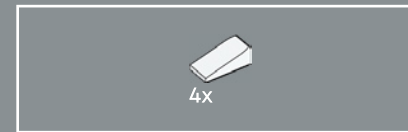

450



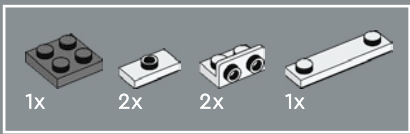

451

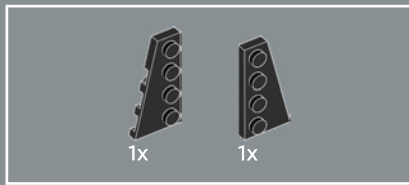
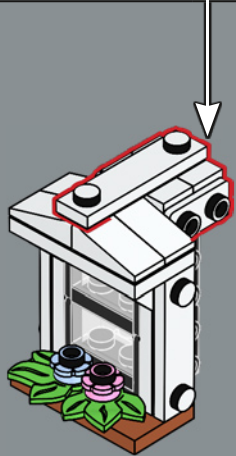
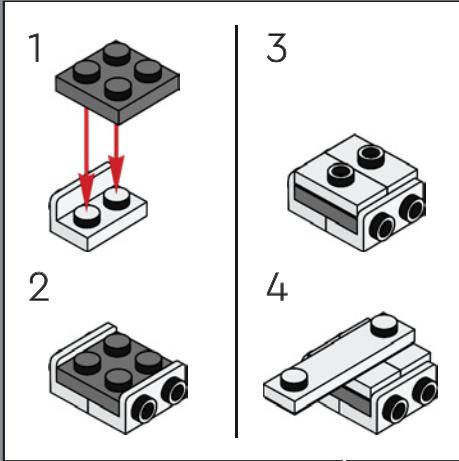

452

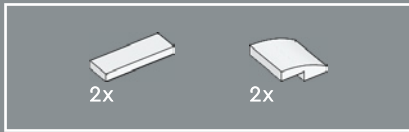
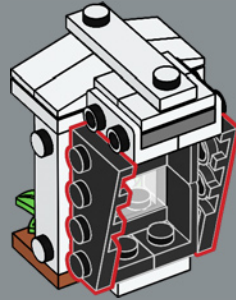

453

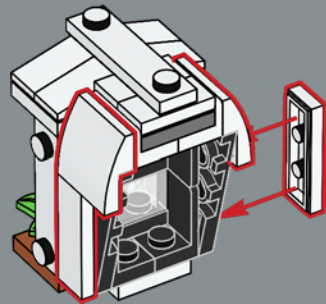

454



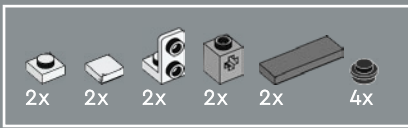

455

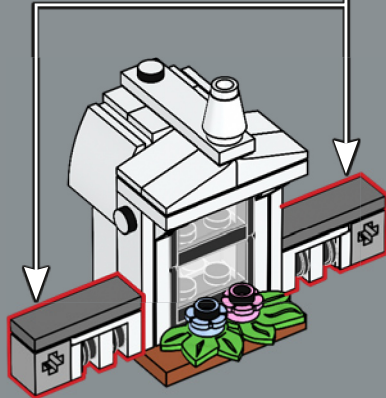
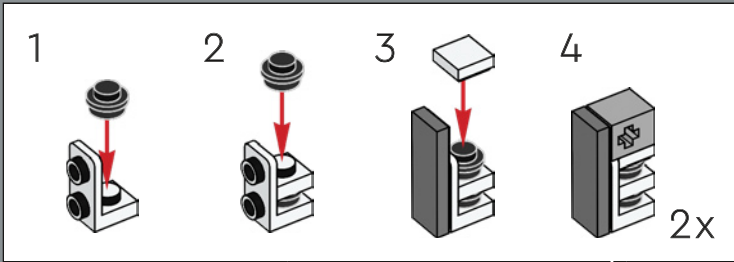

456

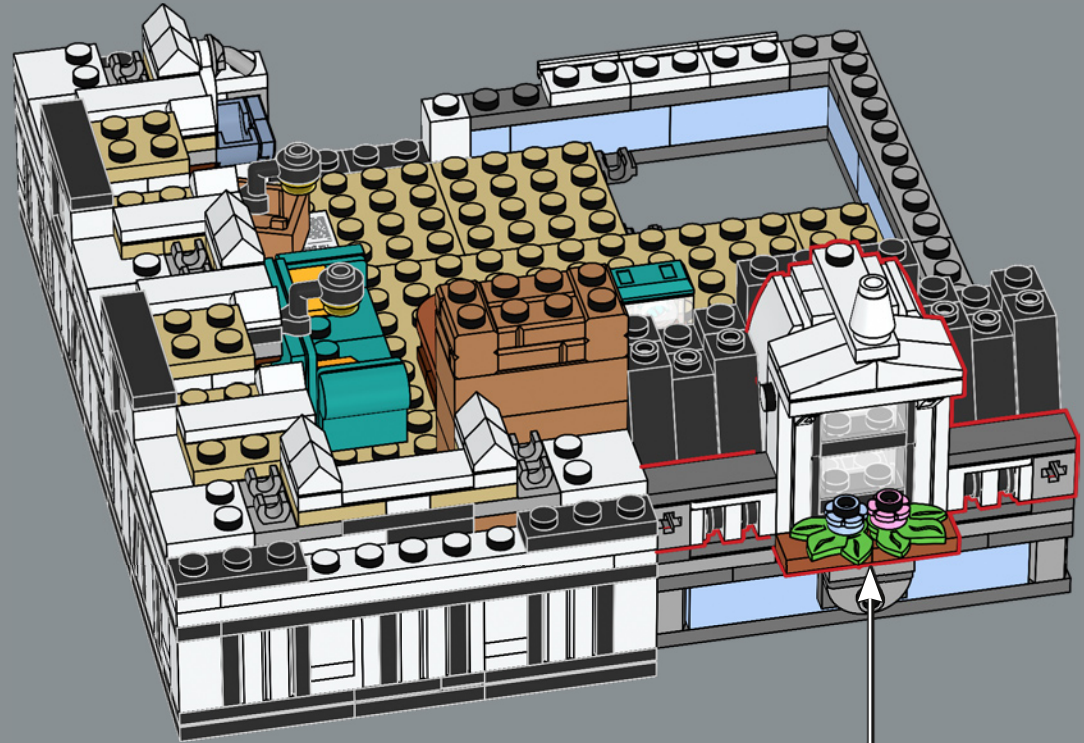

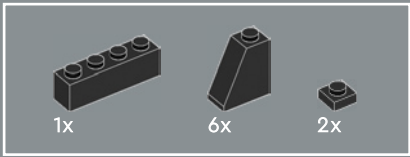

457

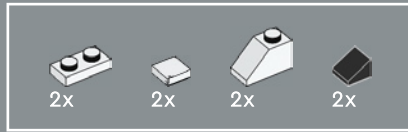
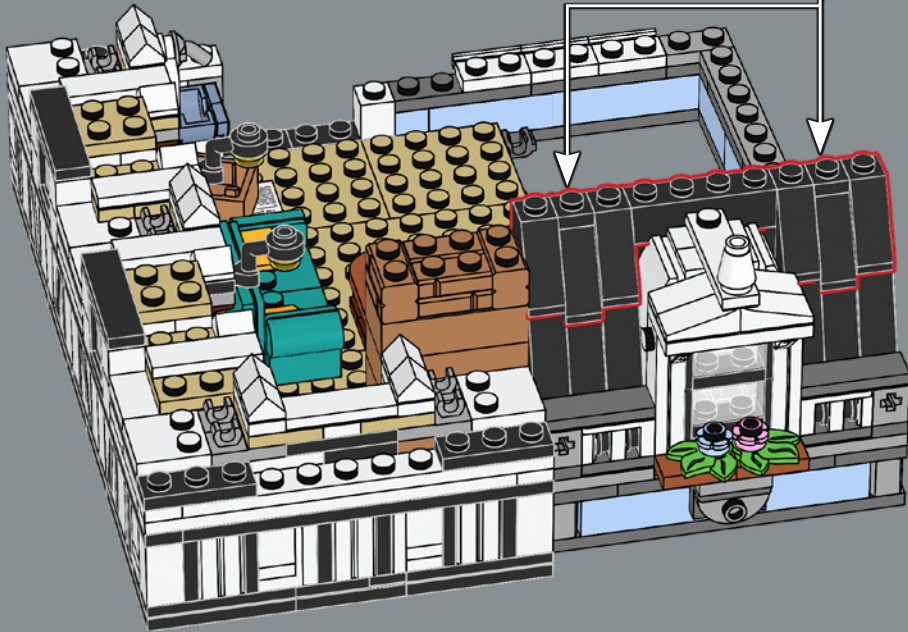
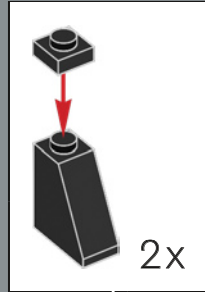

458

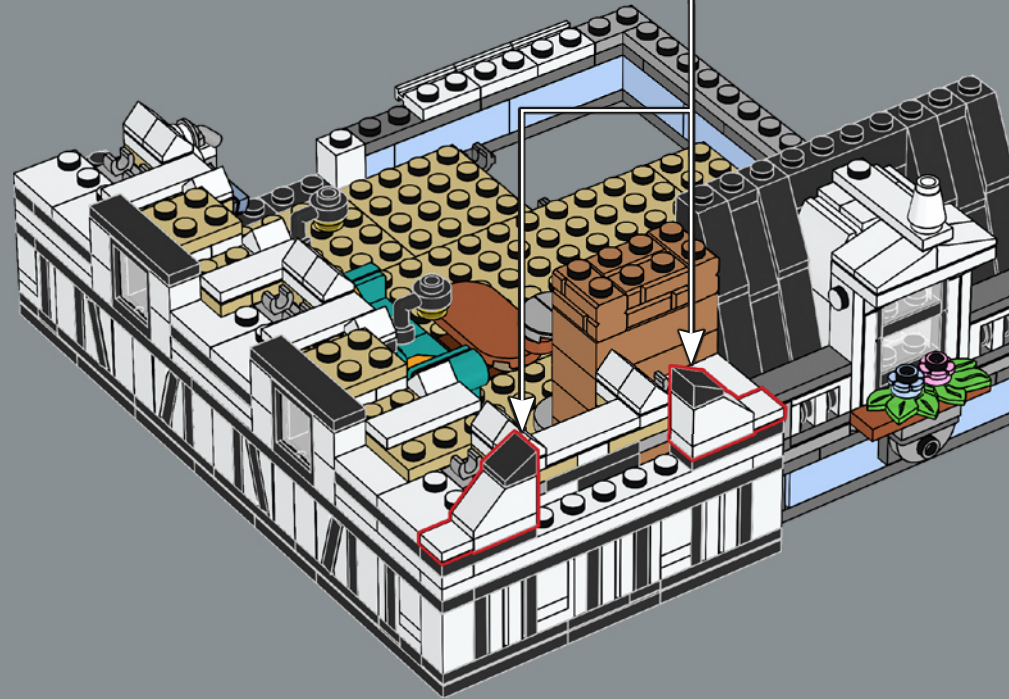
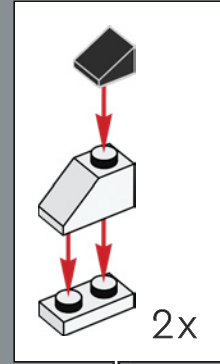



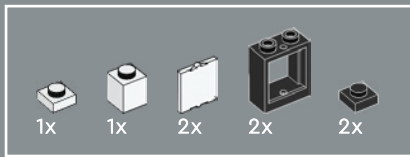

459

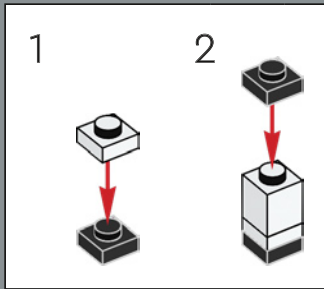
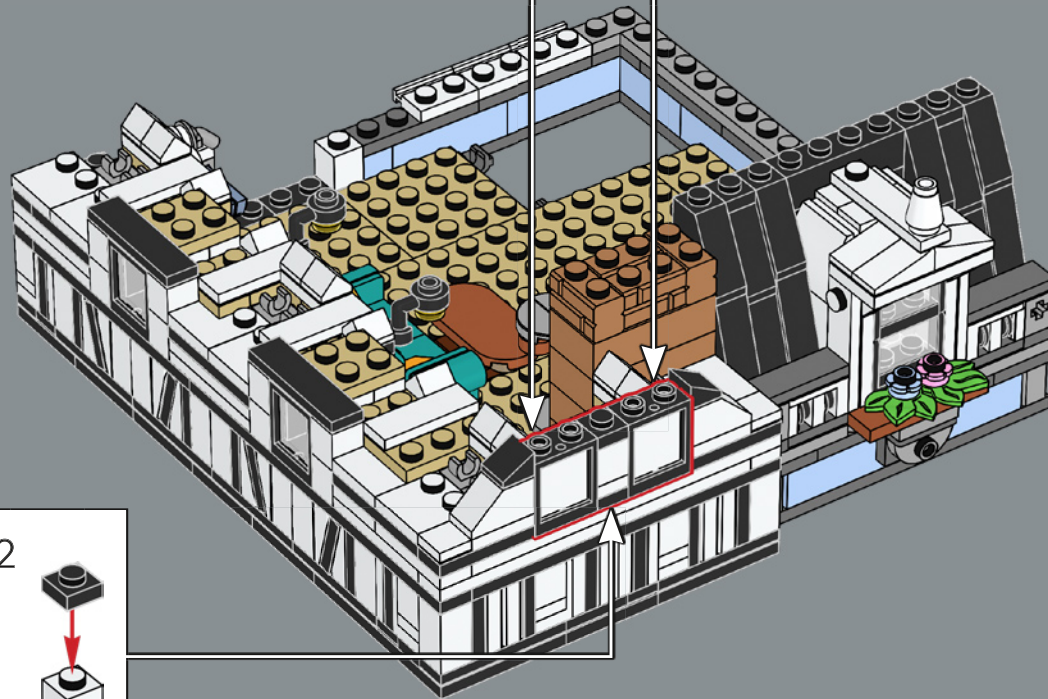
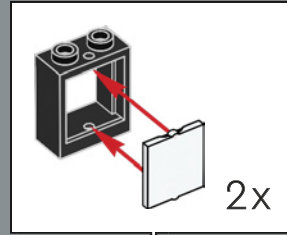

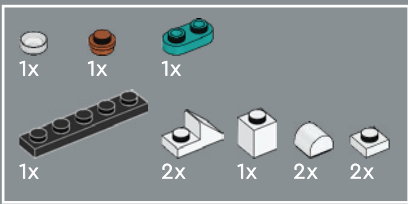

460

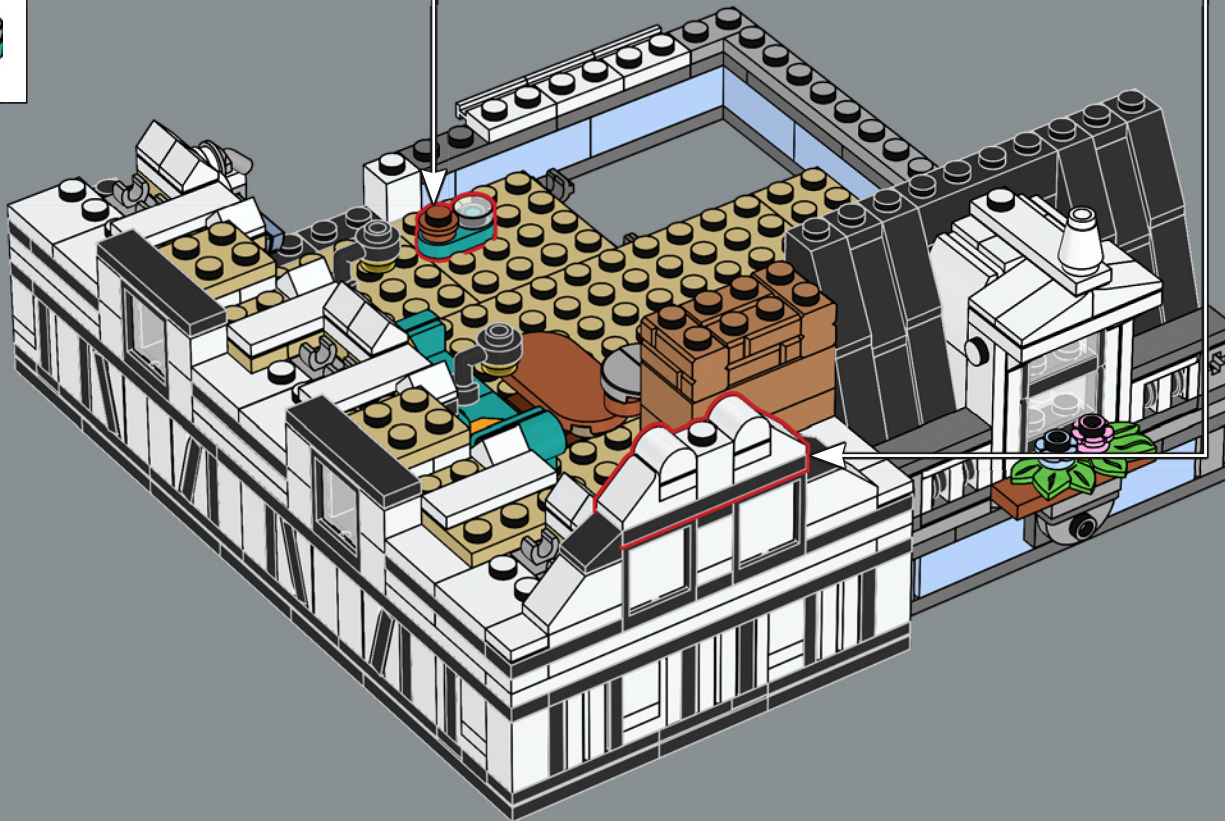
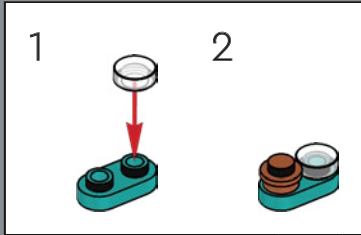
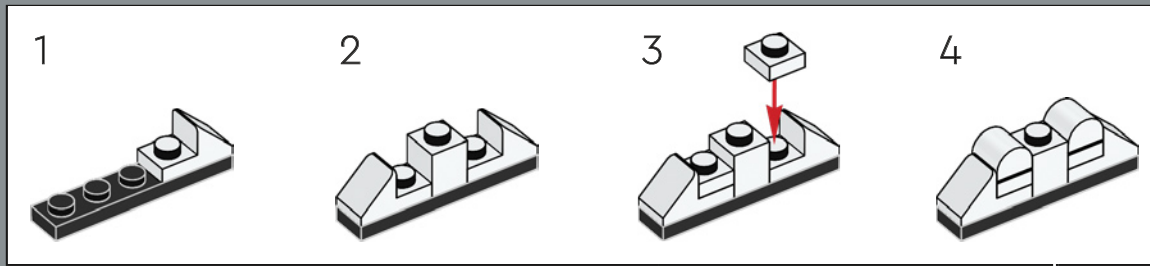

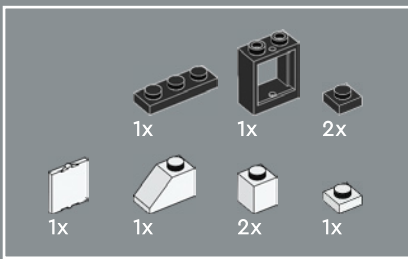

461



1

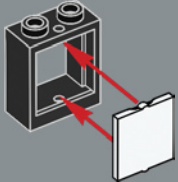

3



1



2



2



4

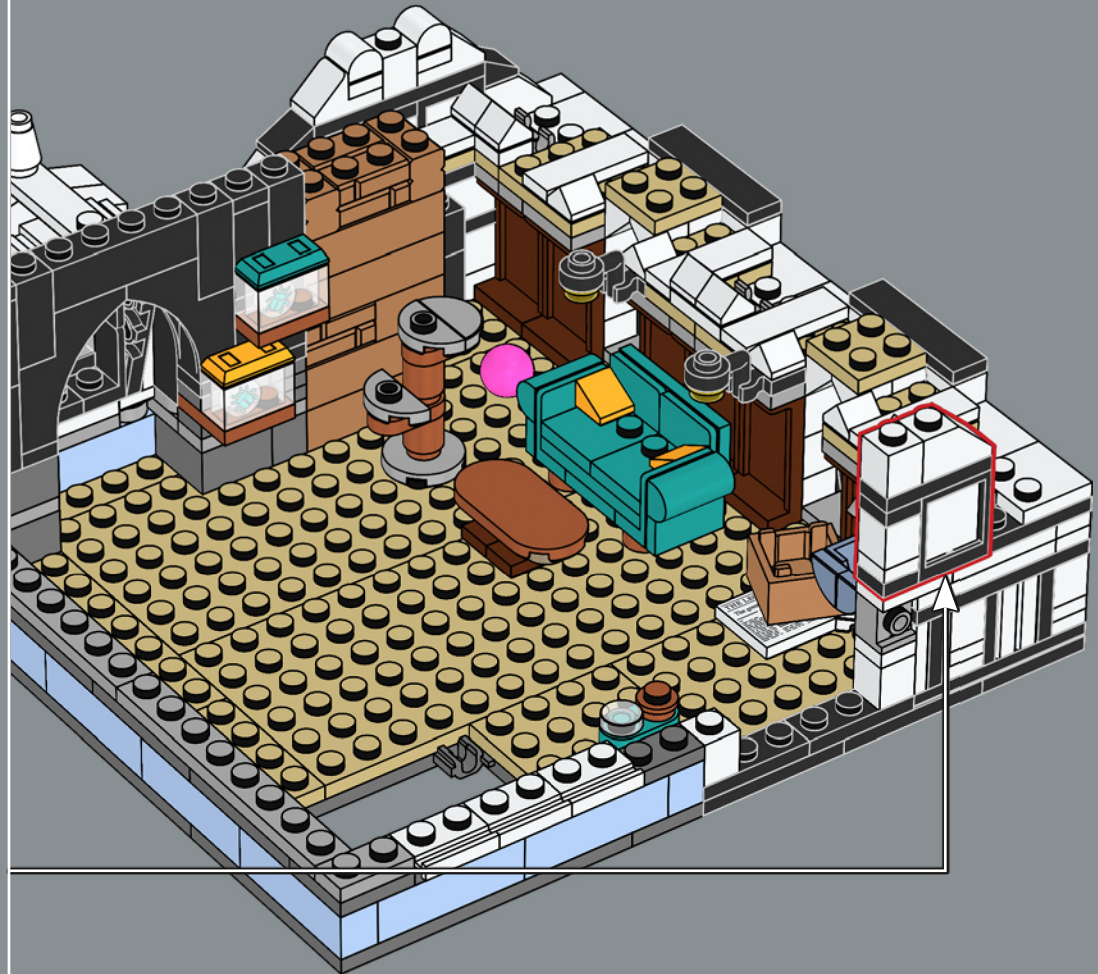
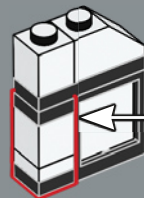

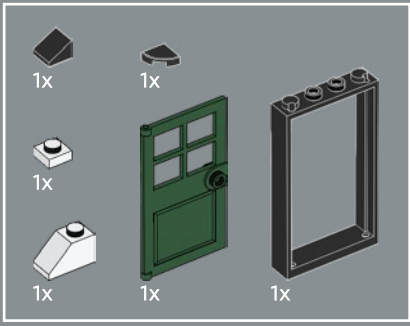

462

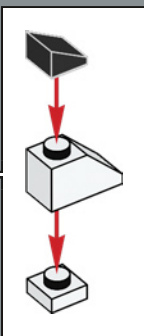
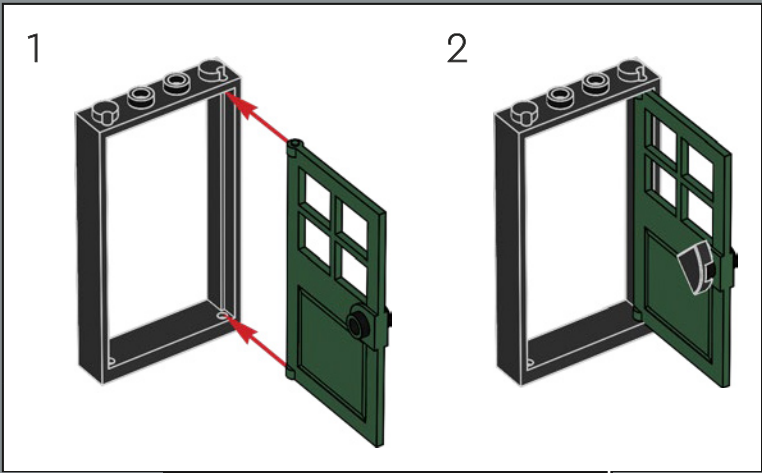

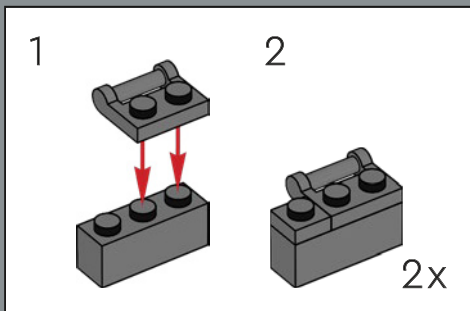
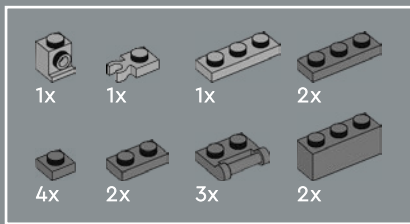

463

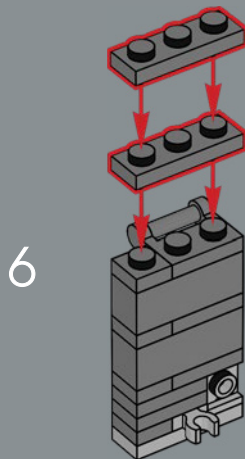
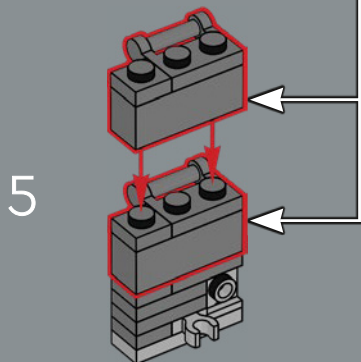
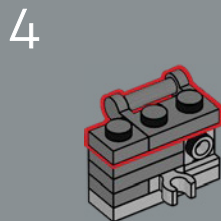
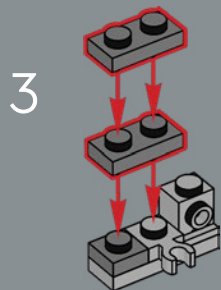
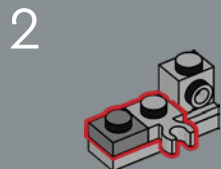
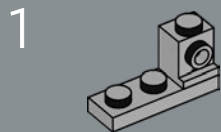

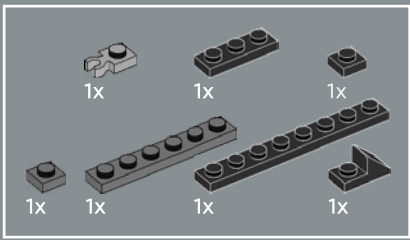

464

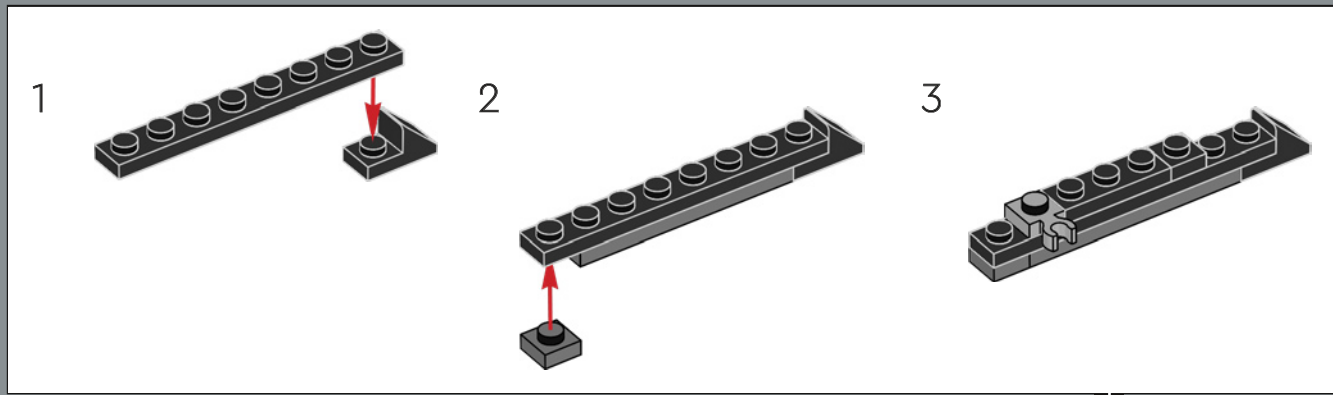

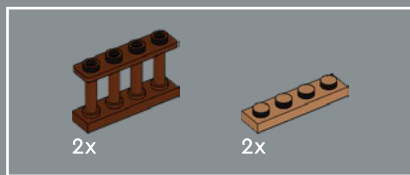

465

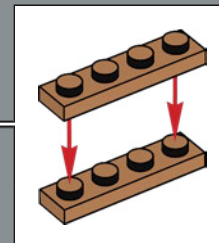

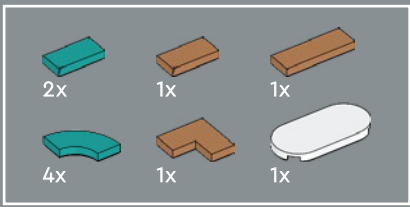

466







467

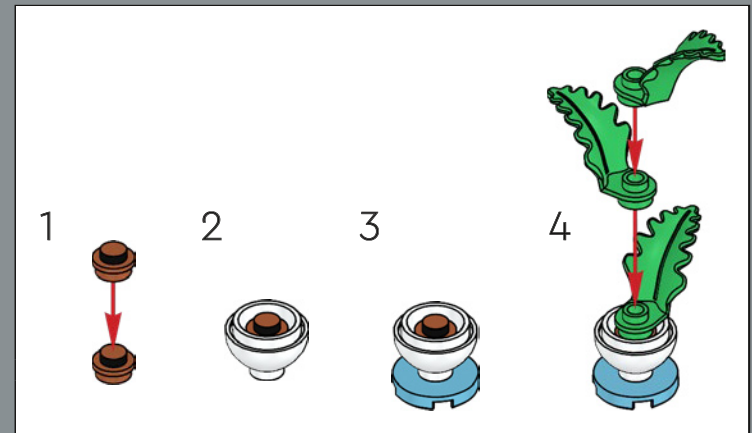

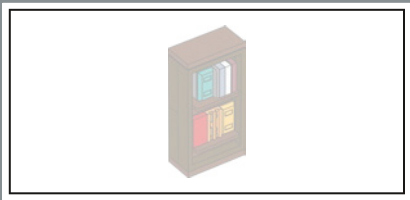

468

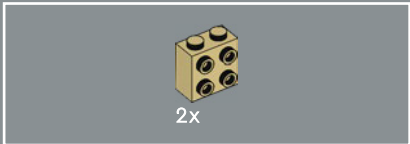
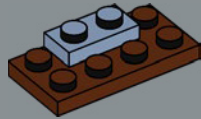

469

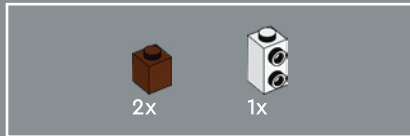
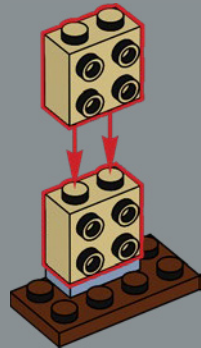

470

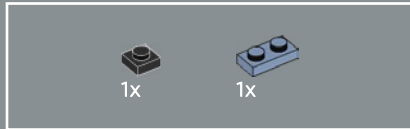
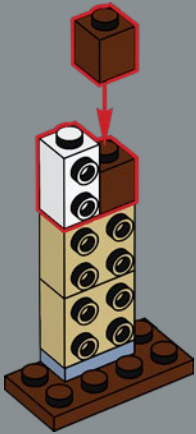

471

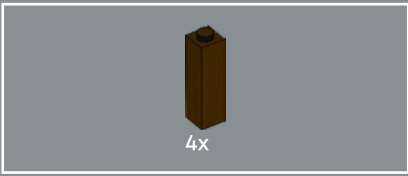
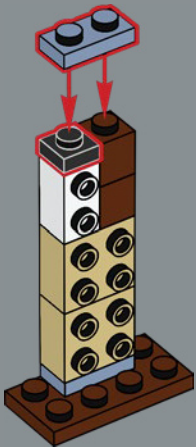

472

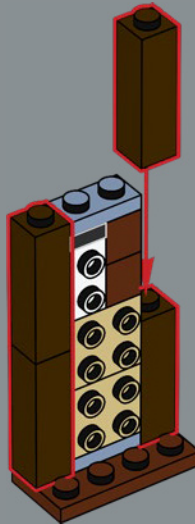

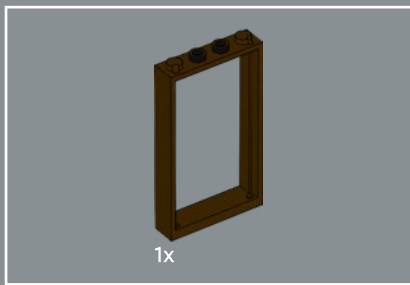

473

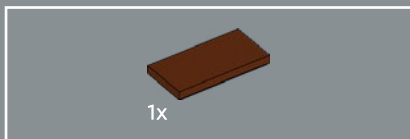

474

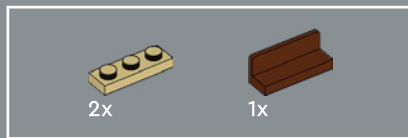
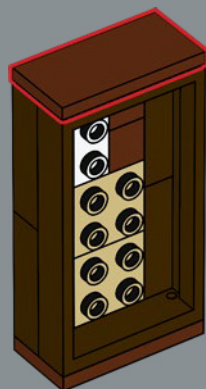

475

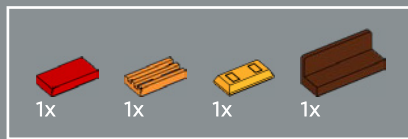
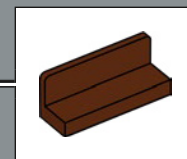
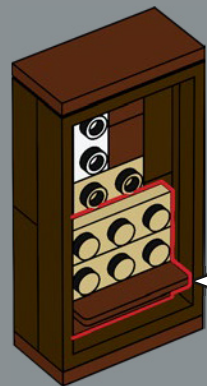

476

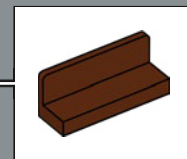

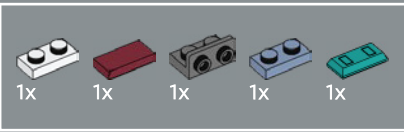

477

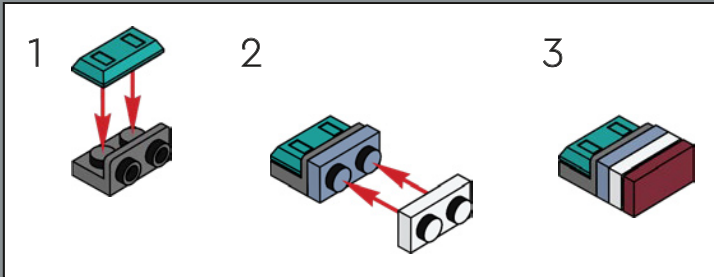

478



The tenant of this cozy studio loves rainy days so she can stay at home and read the new books that she bought at the LEGO® Creator Expert Bookshop (10270).

La locataire de ce studio douillet adore passer les jours de pluie chez elle à lire les nouveaux livres qu'elle a achetés à la librairie LEGO® Creator Expert (10270).

A la inquilina de este acogedor estudio le encantan los días lluviosos para quedarse en casa leyendo los libros que compra en la Librería LEGO® Creator Expert (10270).

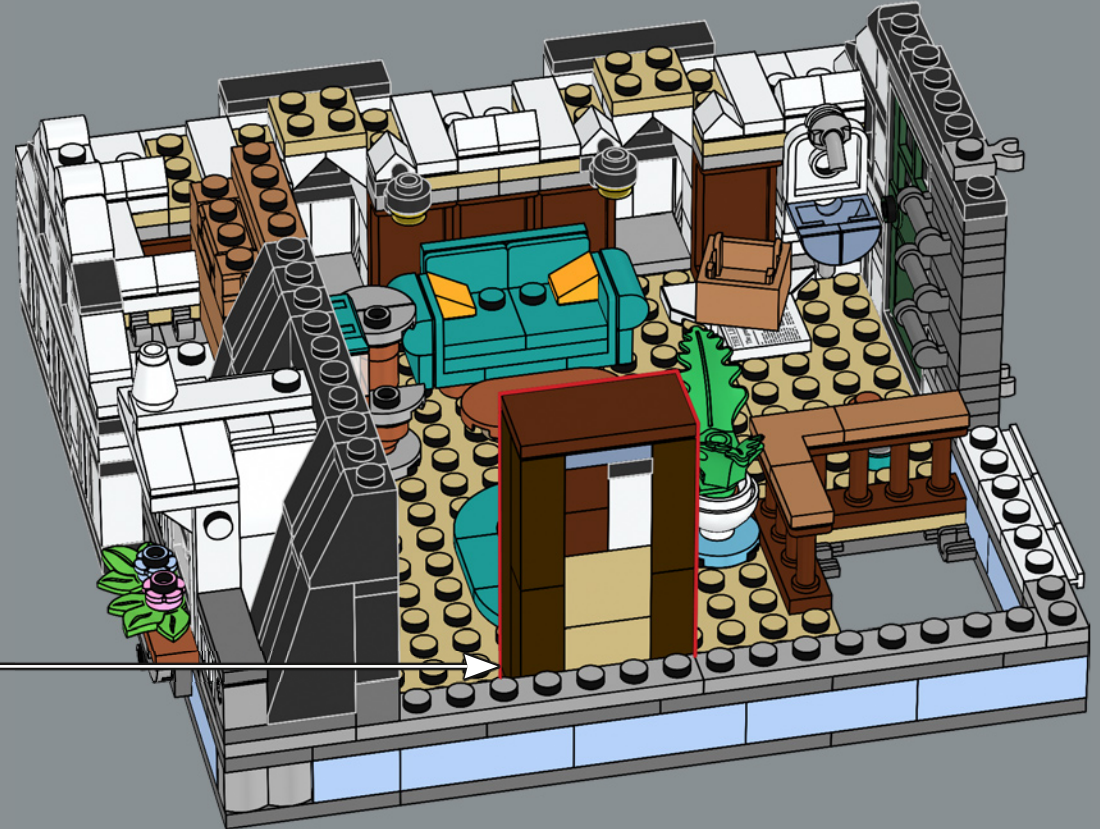

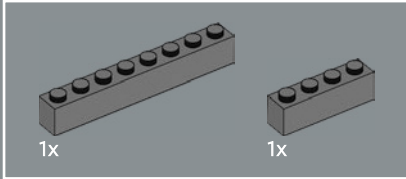
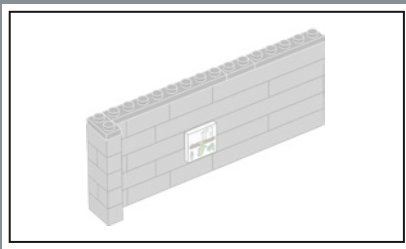

479

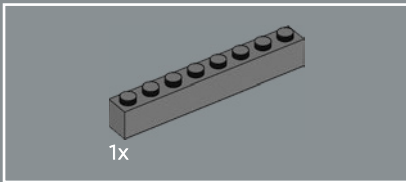
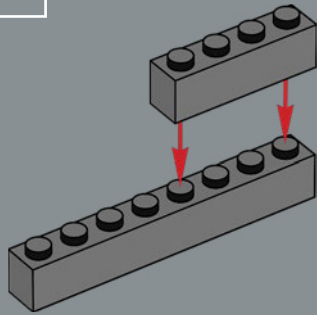

480

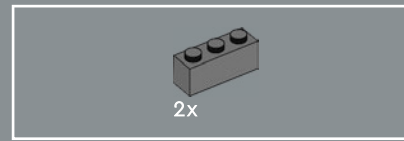
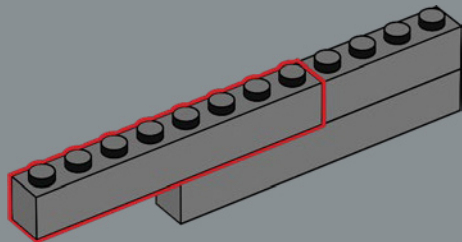

481

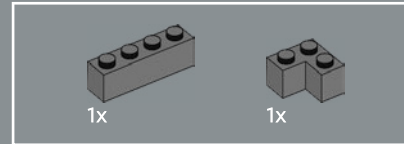
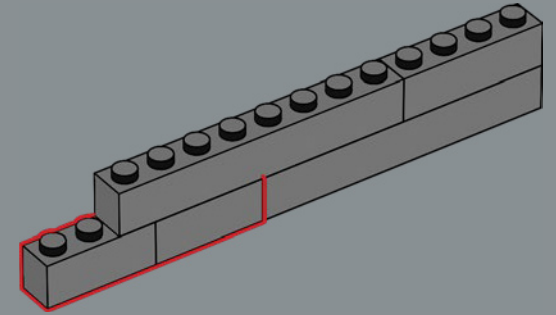

482

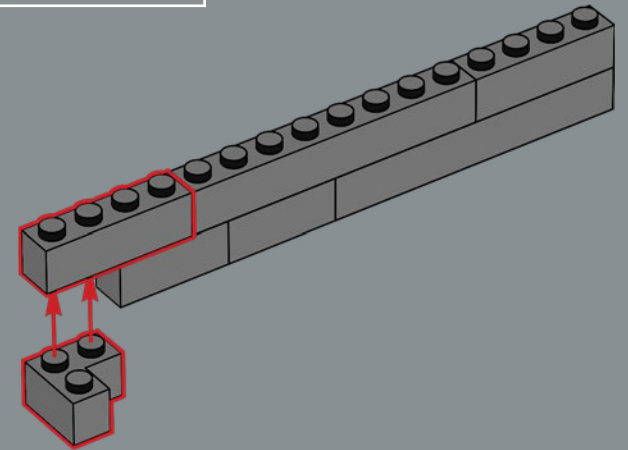



1x

483

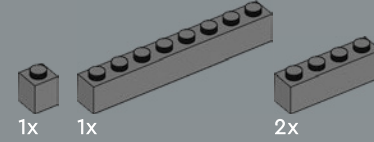
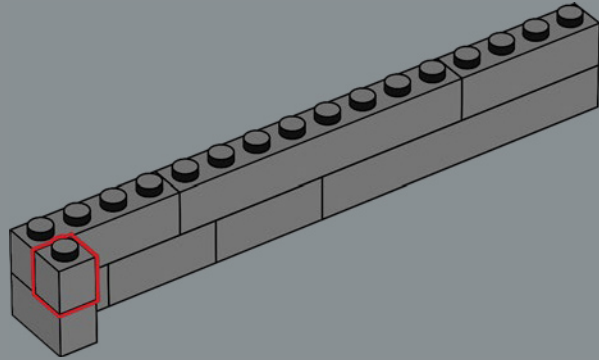

1x

1x

2x

485

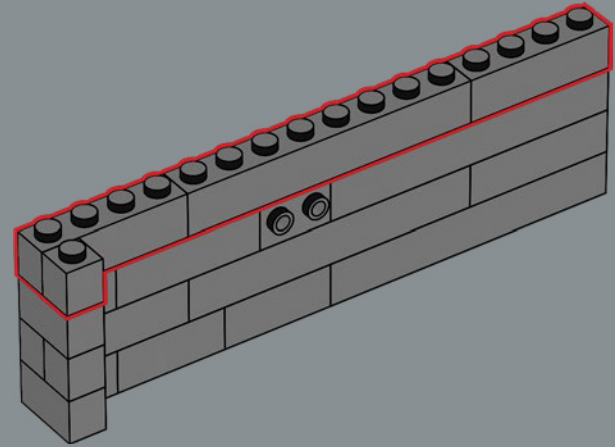

1x

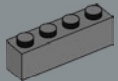

1x



1x

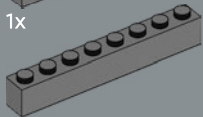

1x

484

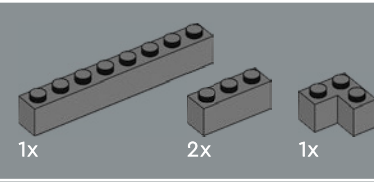
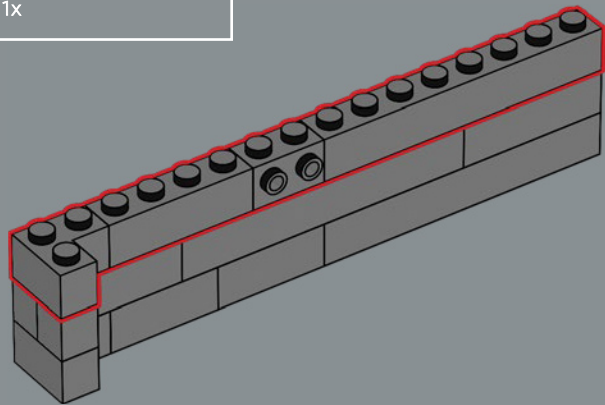

1x

2x

1x

486

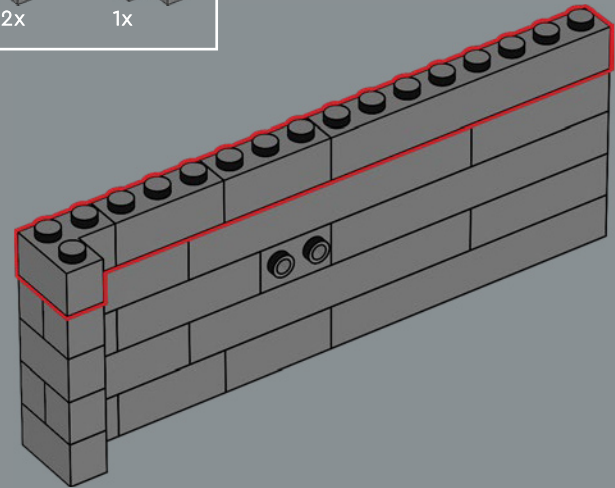

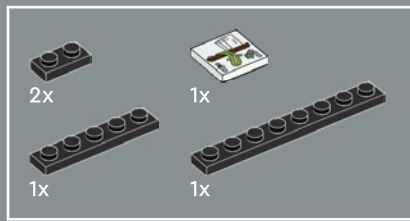

487

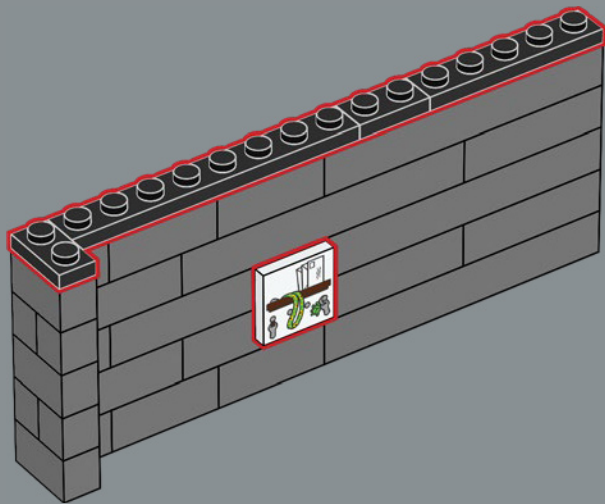

488



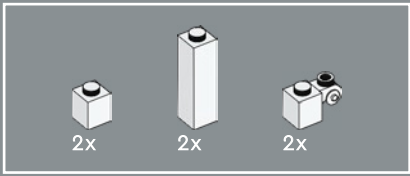

489

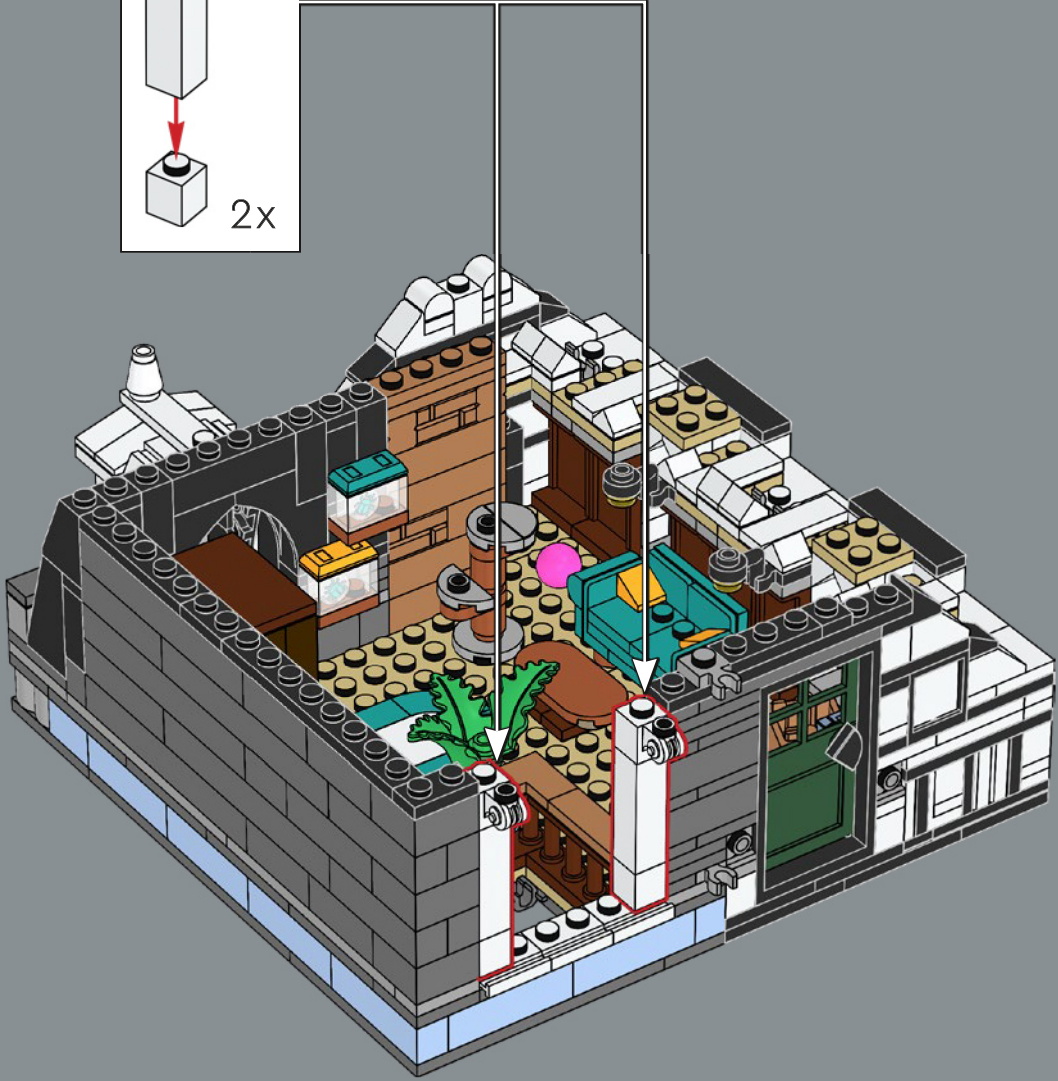
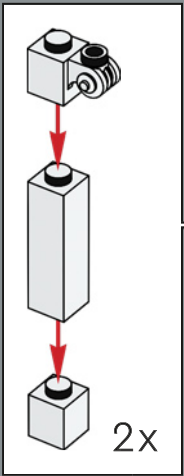



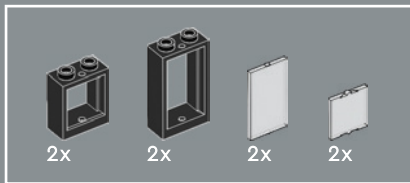

490

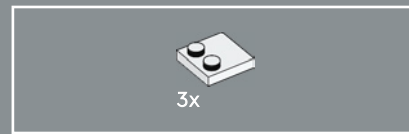
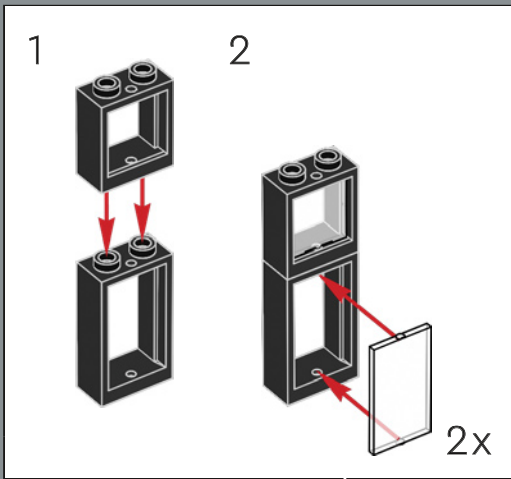

491



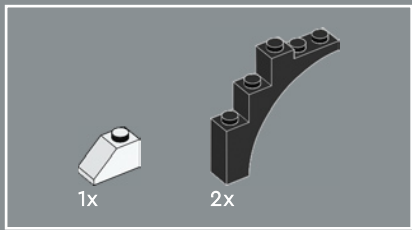

492

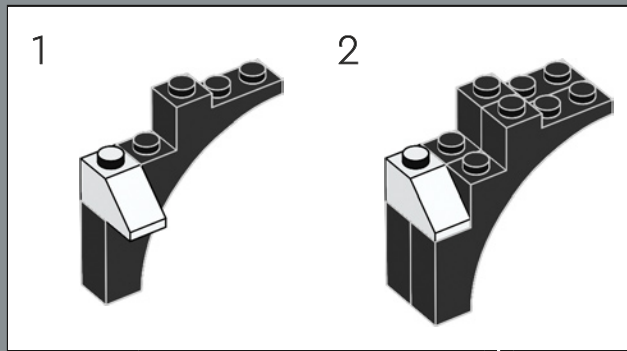

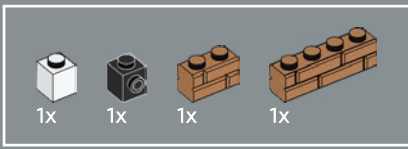

493



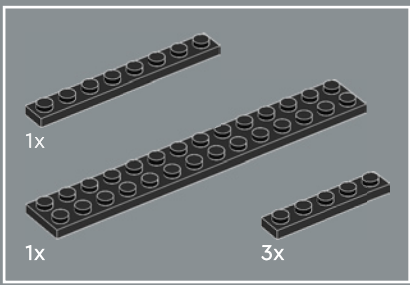

494

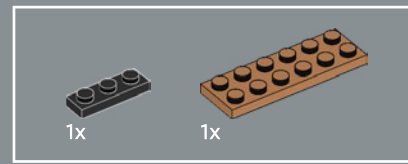

495



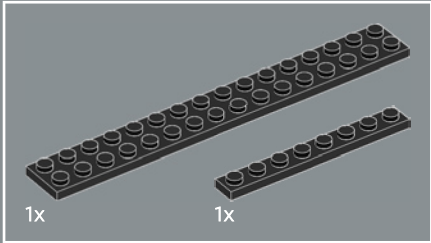
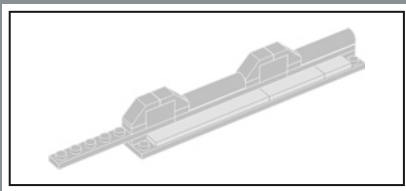

496

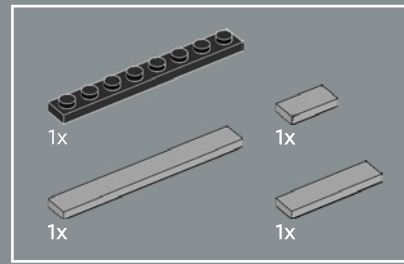
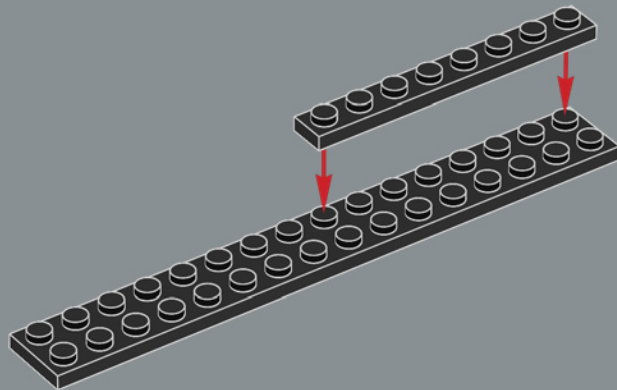

497

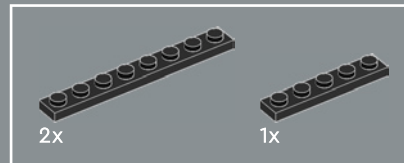
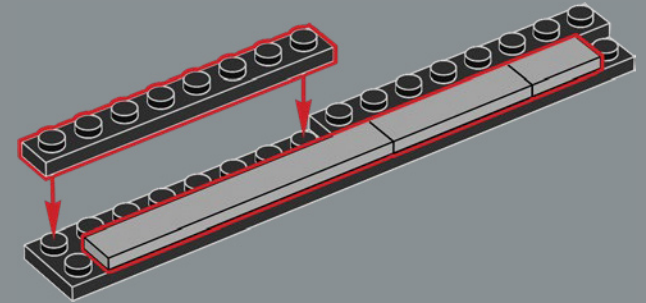

498

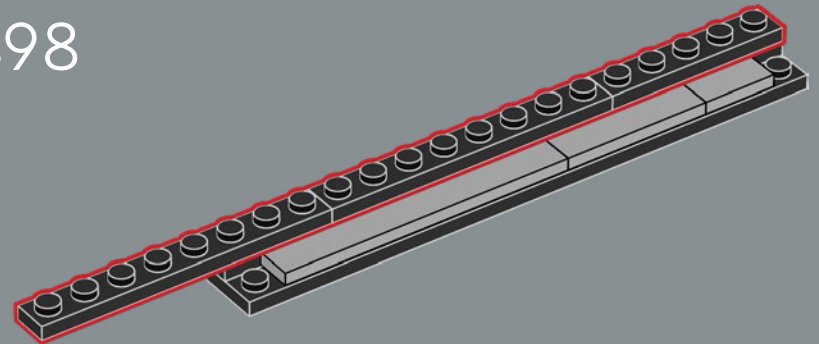



499

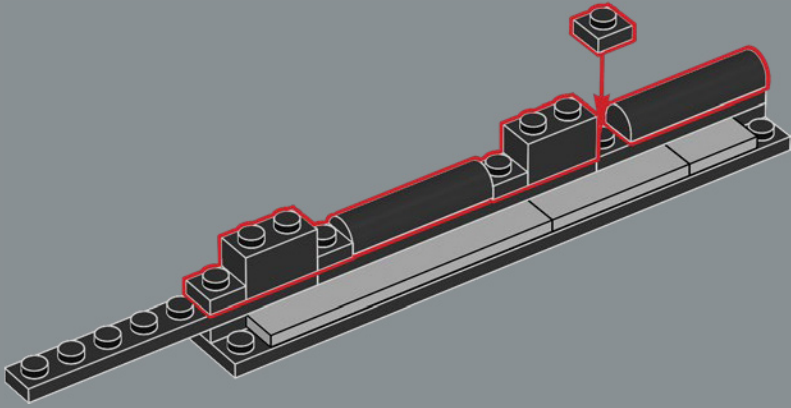

500

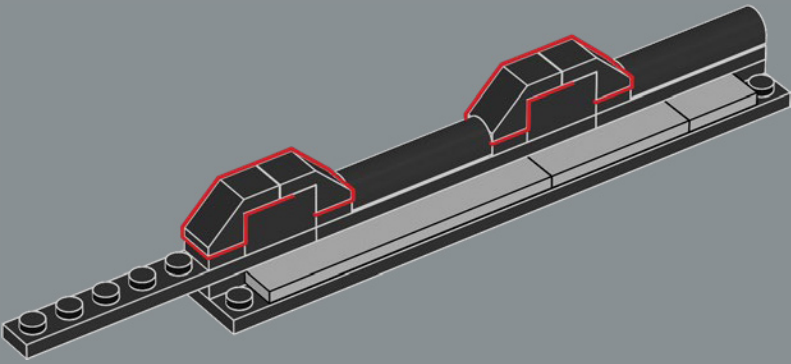

501

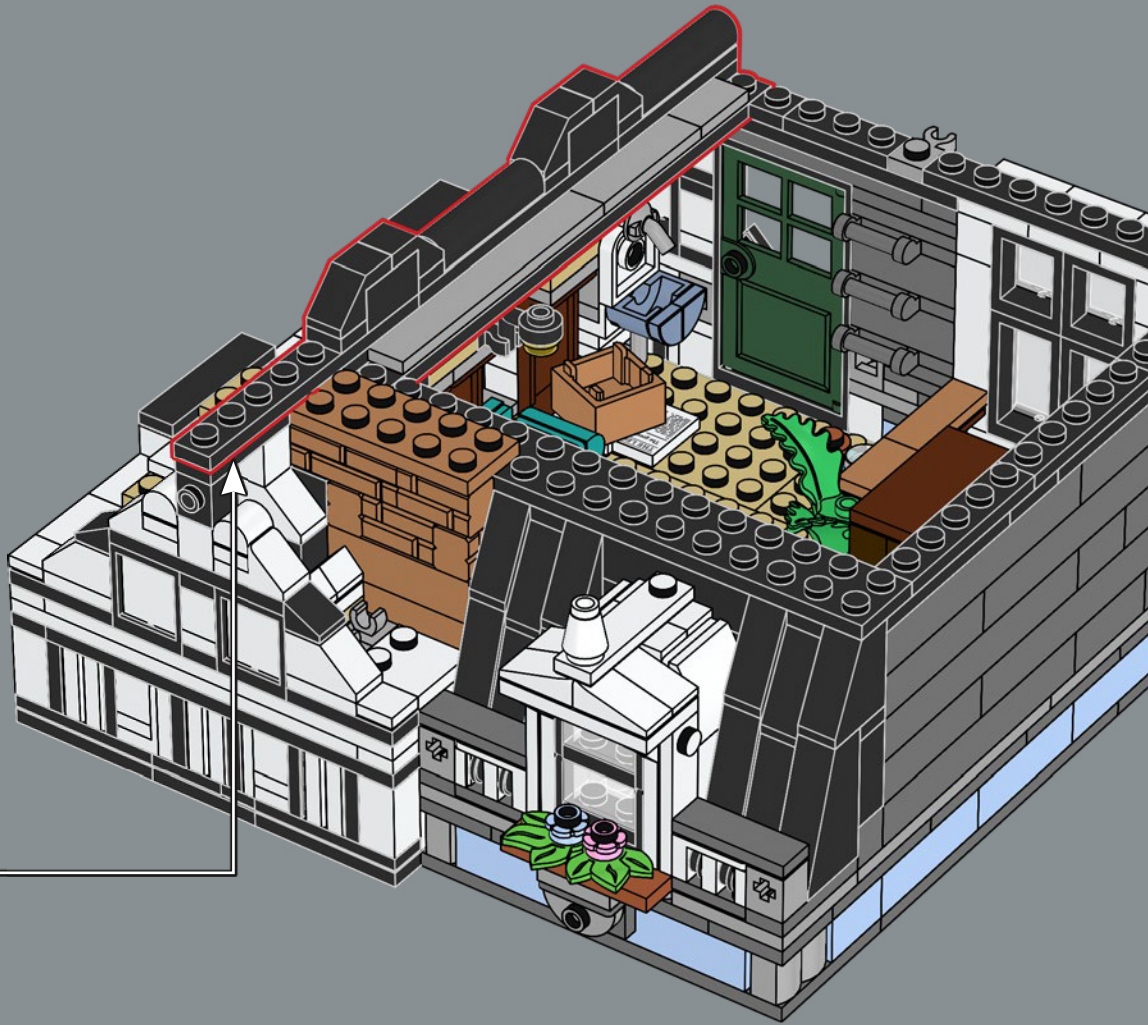

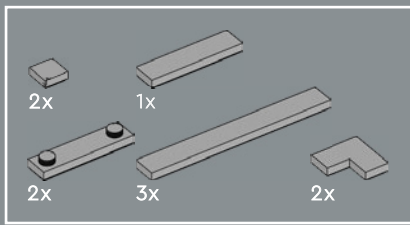

502





503



504





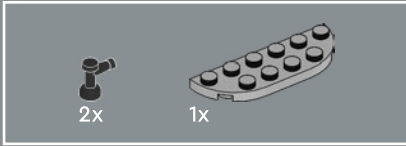

505

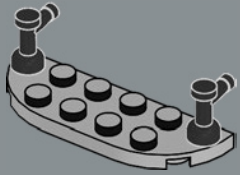

506

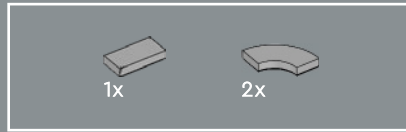
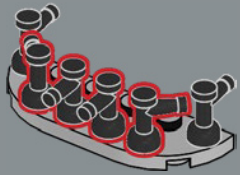

507

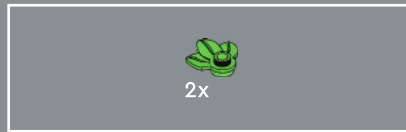
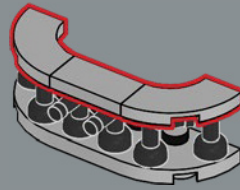

508

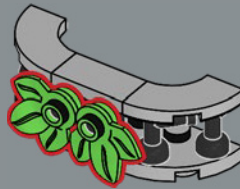

509

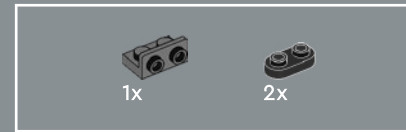
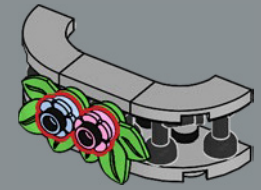

510

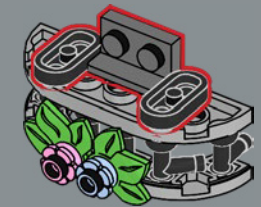



1x



2x

511

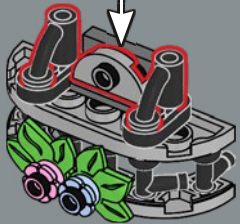

512



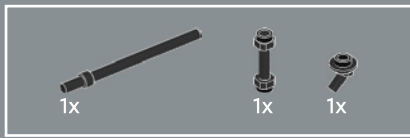

513

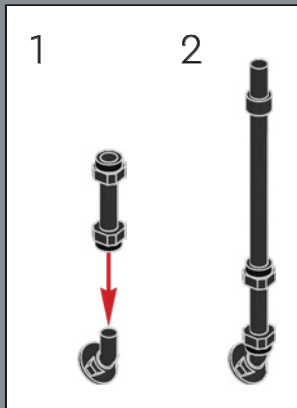



514



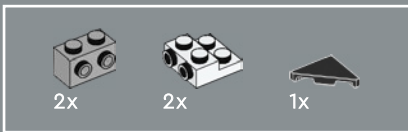

515

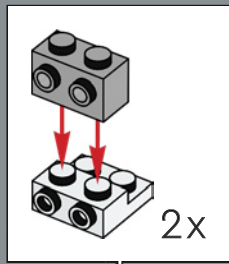

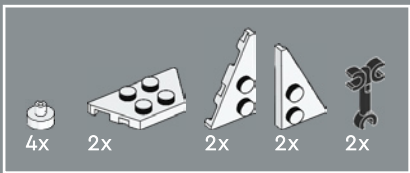

# 516

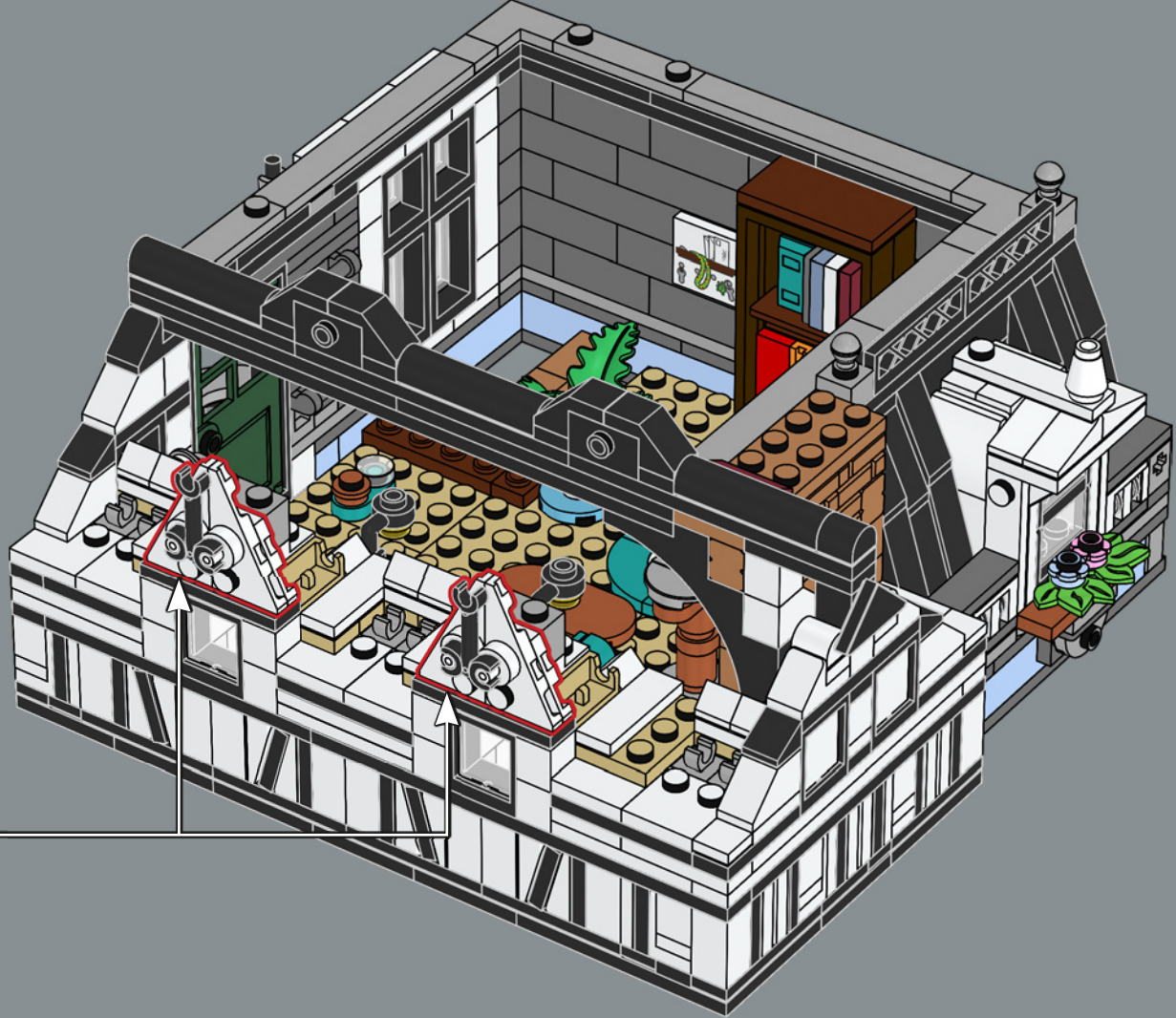
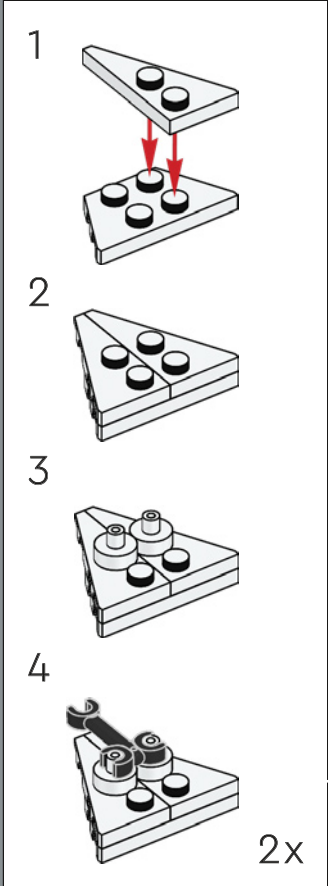

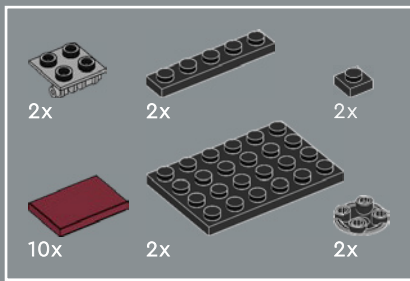

517

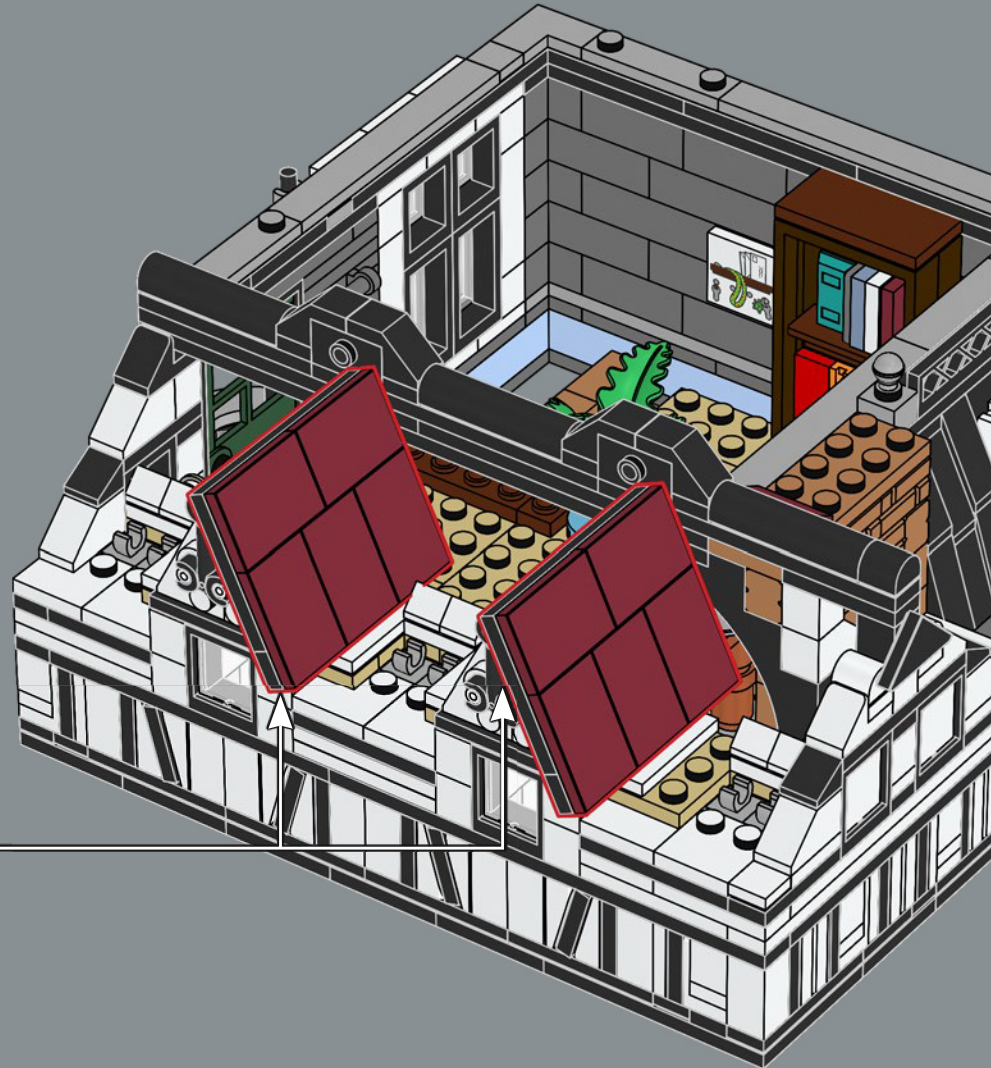
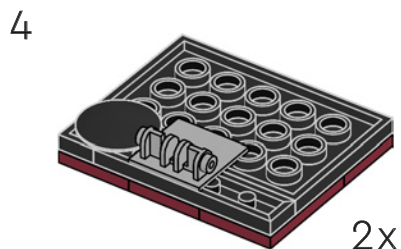
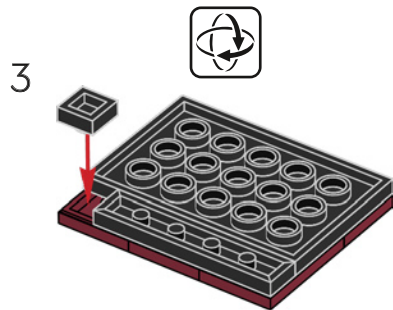
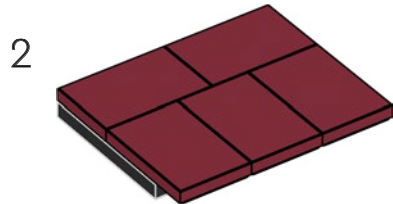
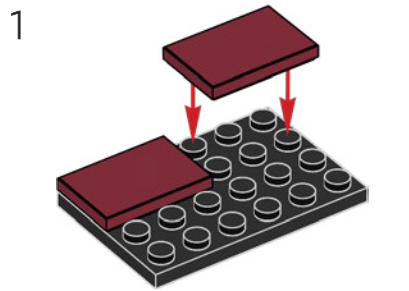

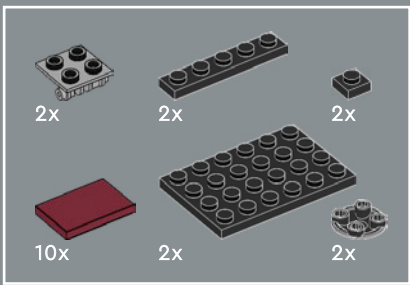

518

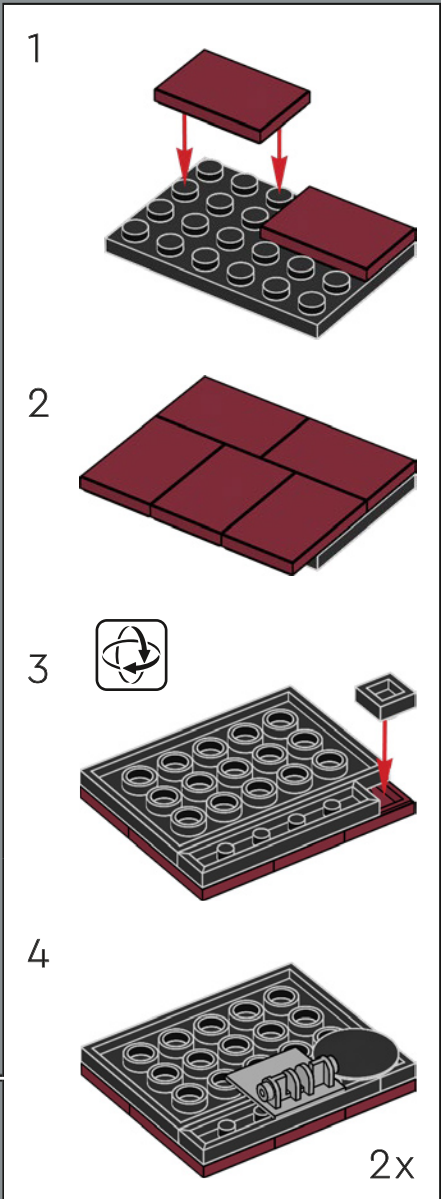



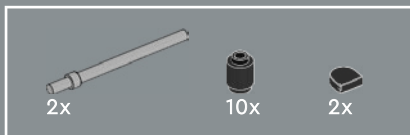

519

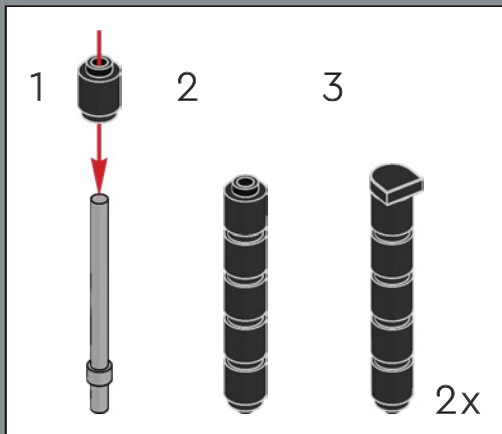

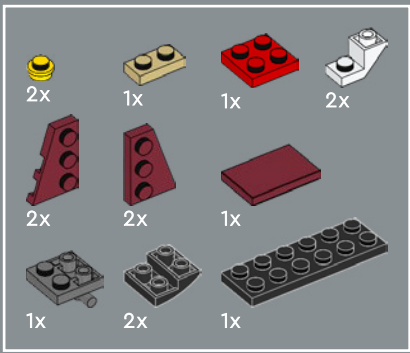

520

1

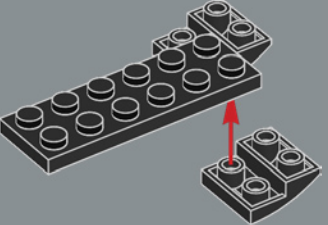

2

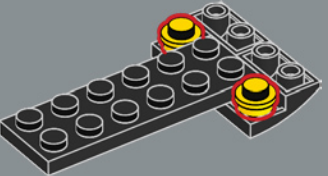

3

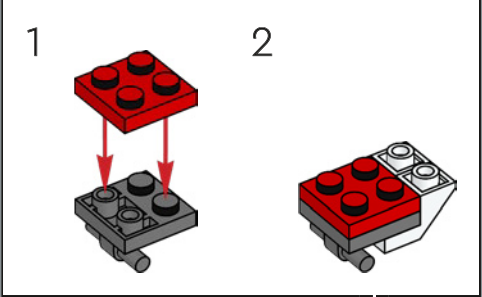
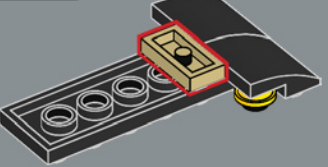

4

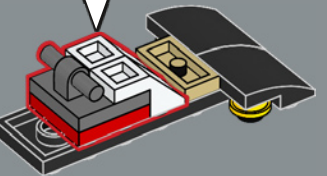

5

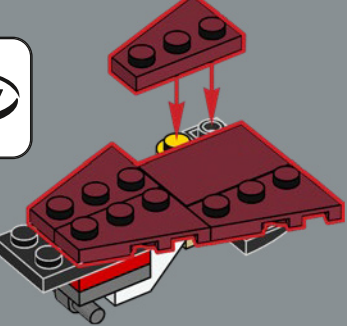

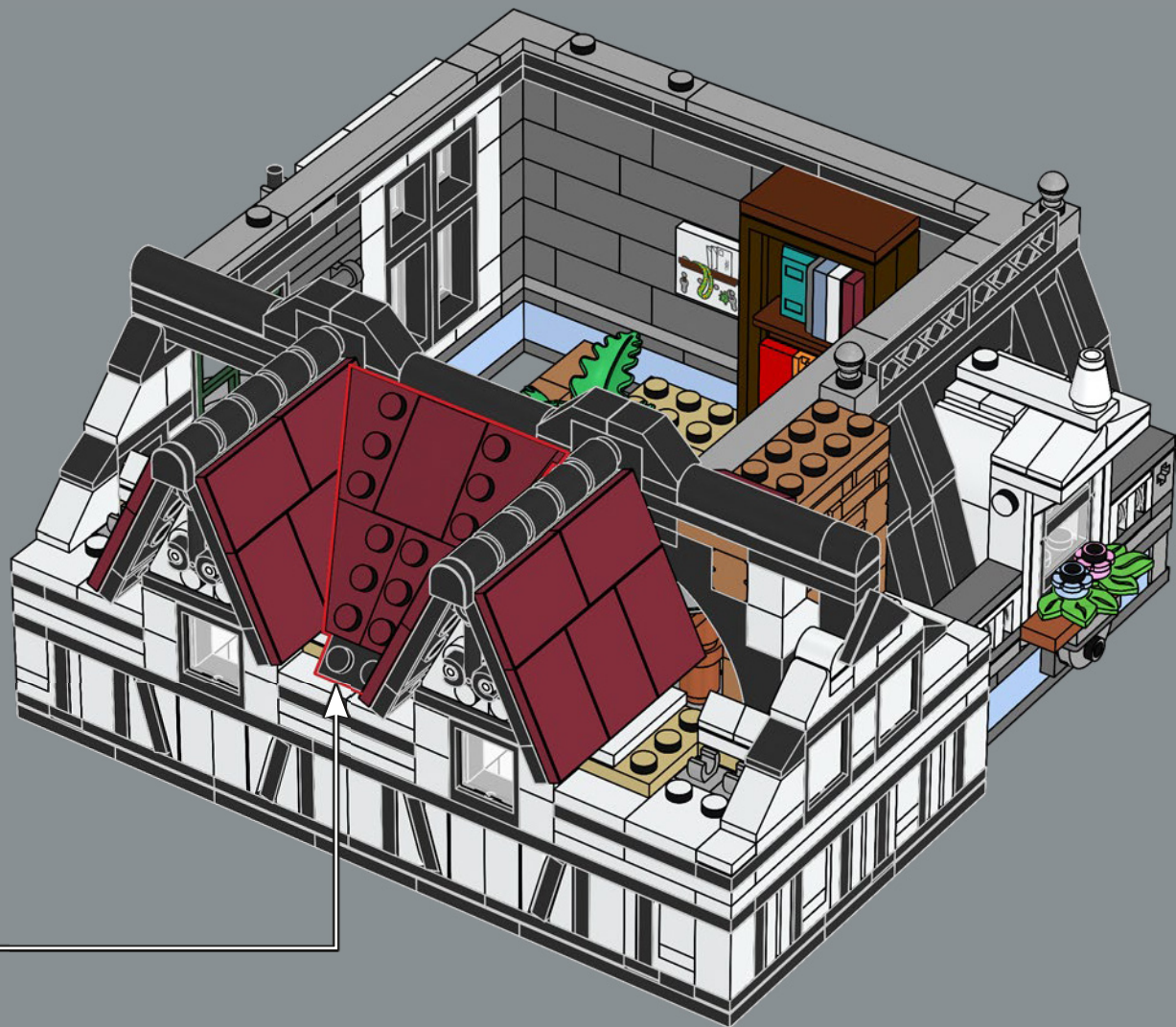

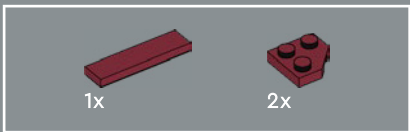

521

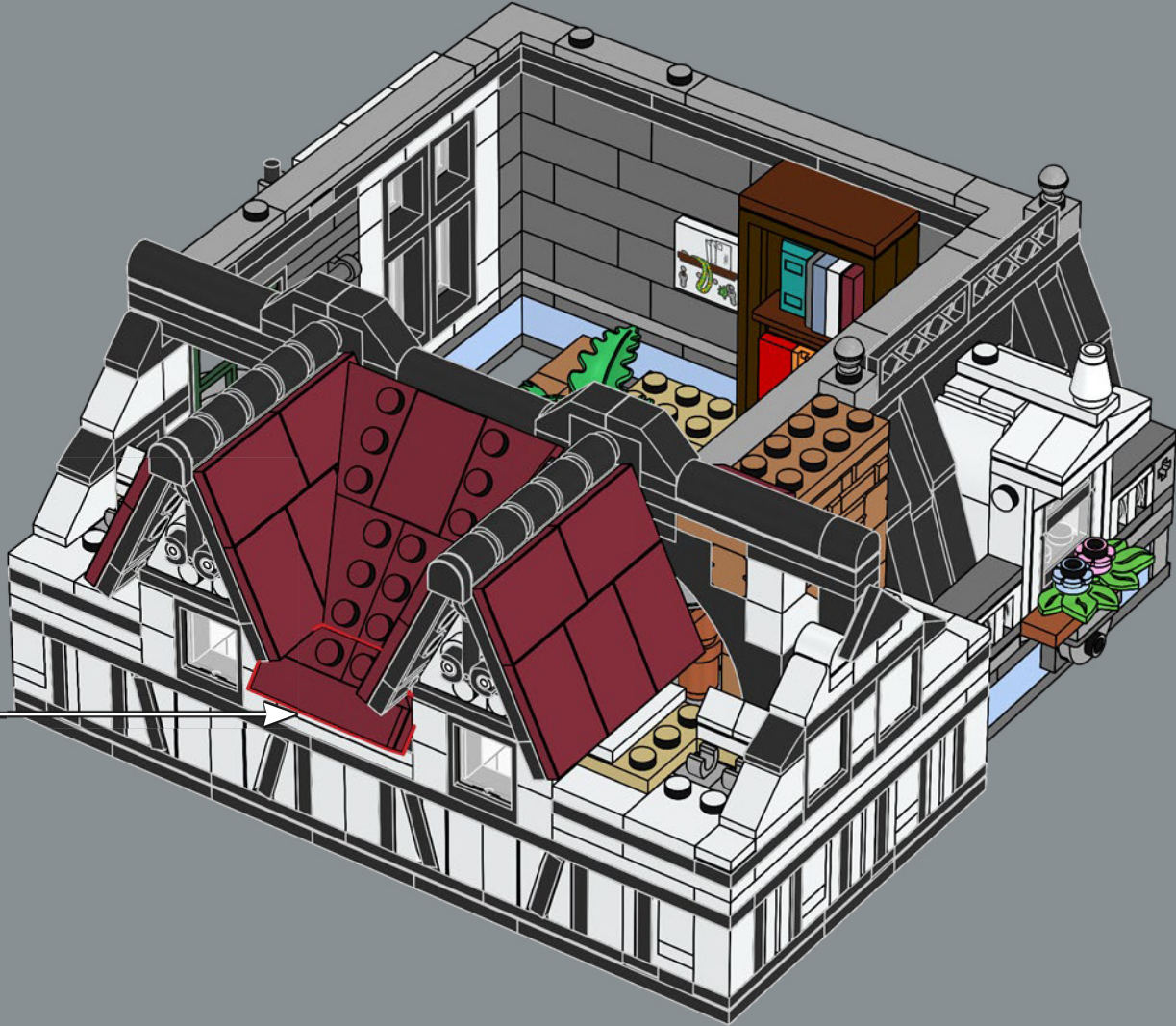
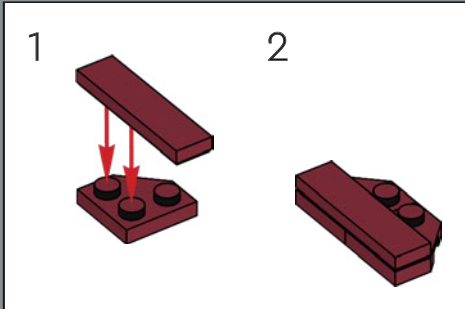

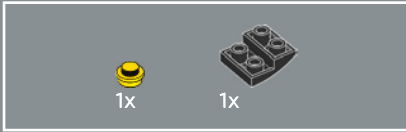
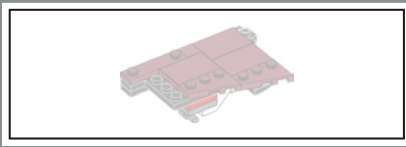

522

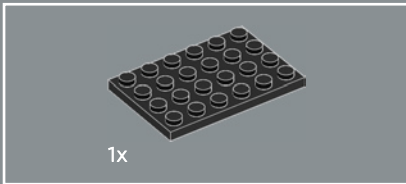
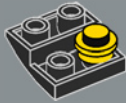

523

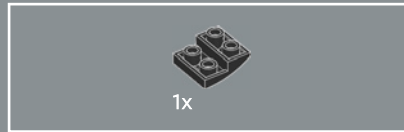
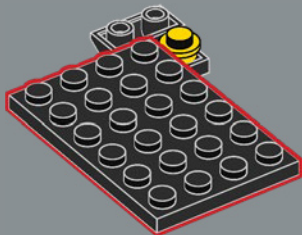

524

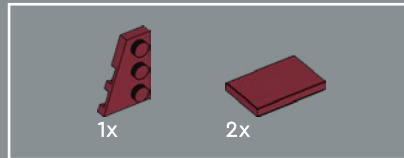
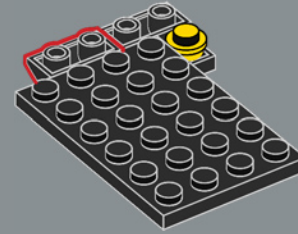

525

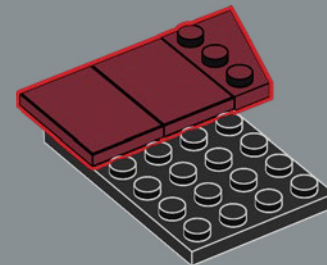

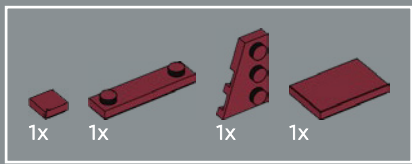

526

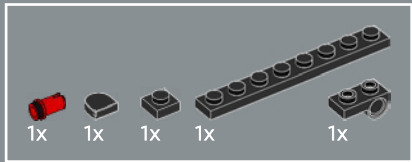
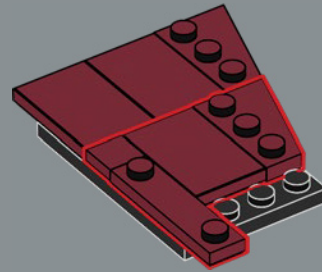

527

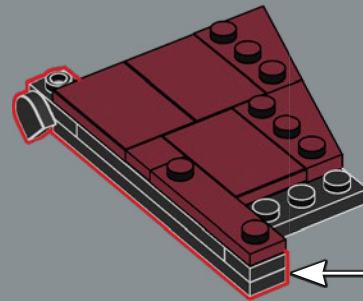
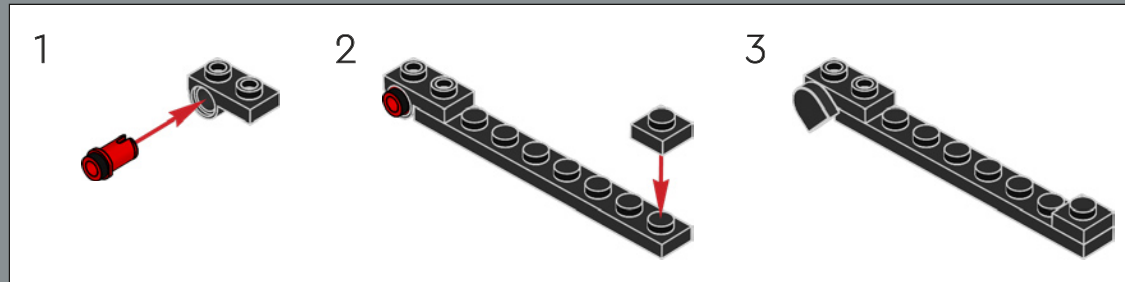

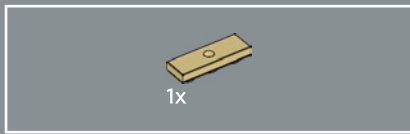

528

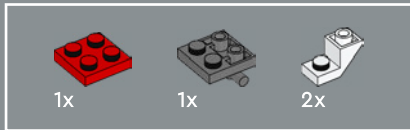
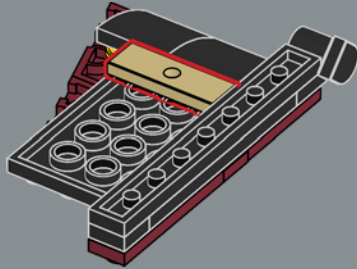

529

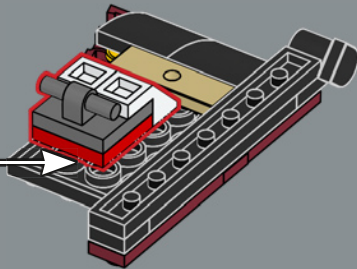
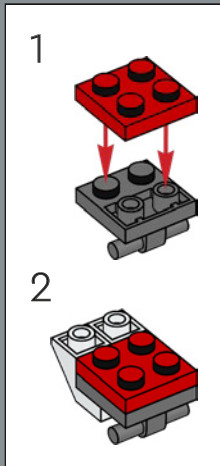

530

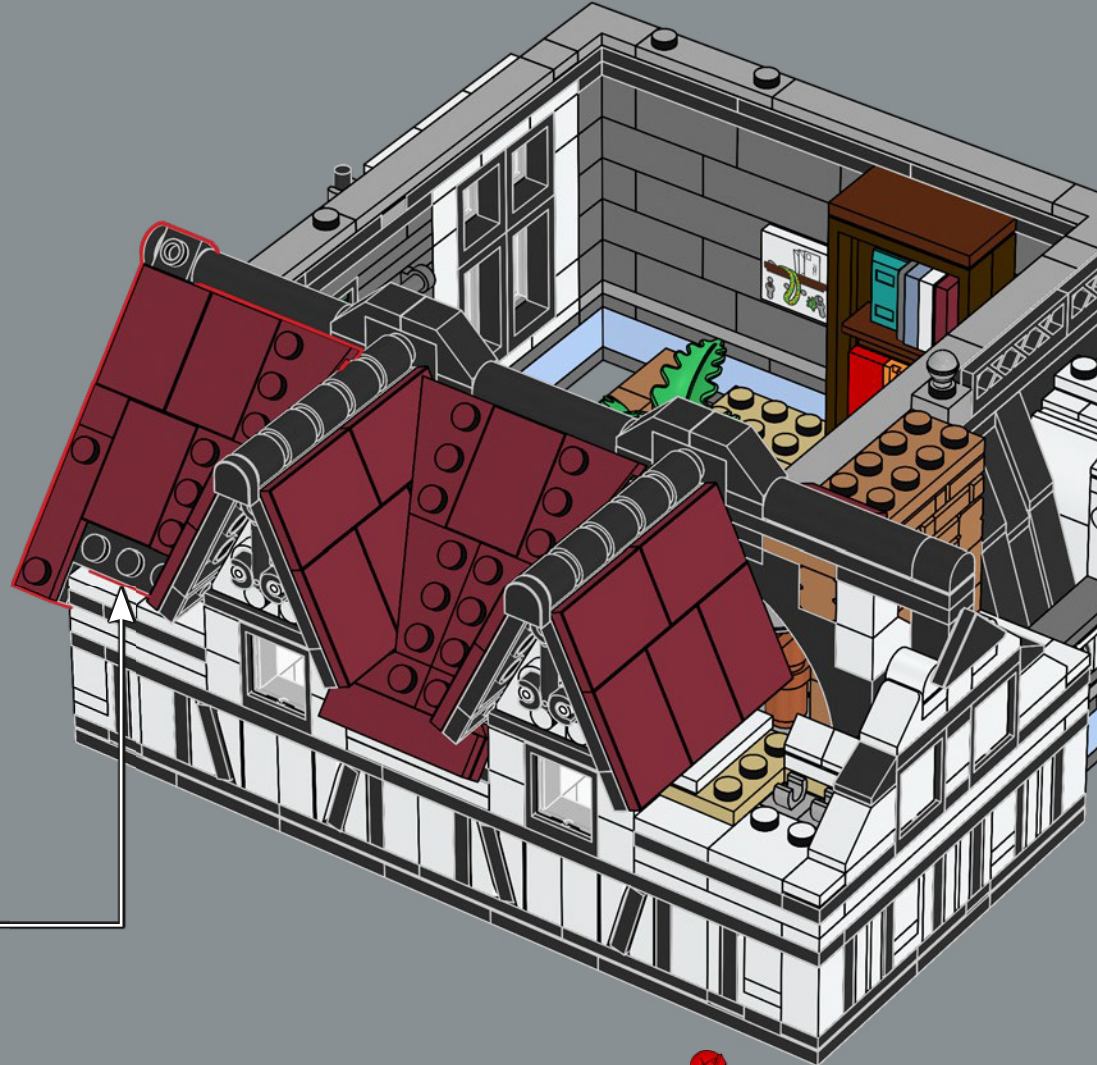

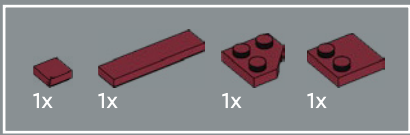

531

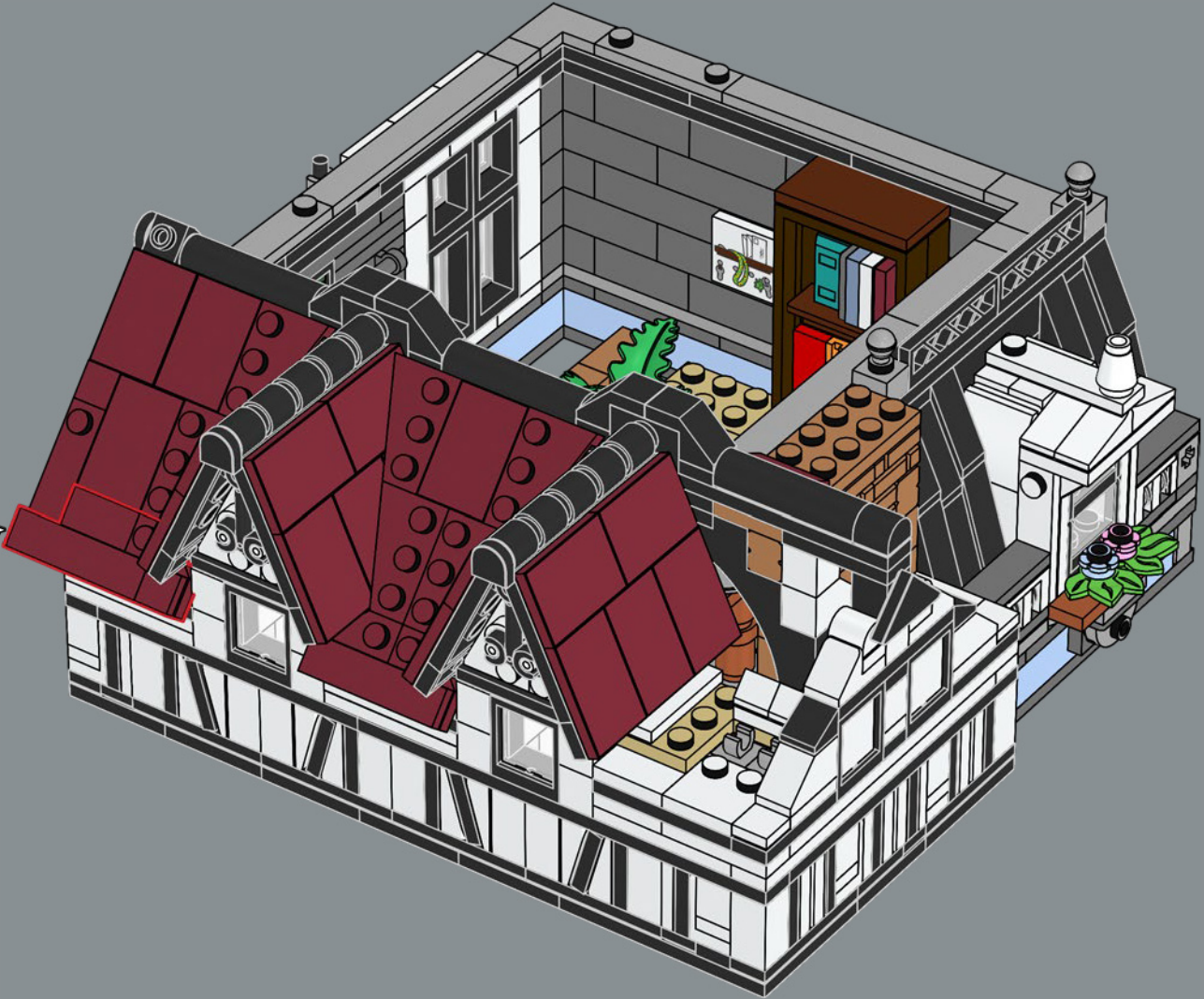
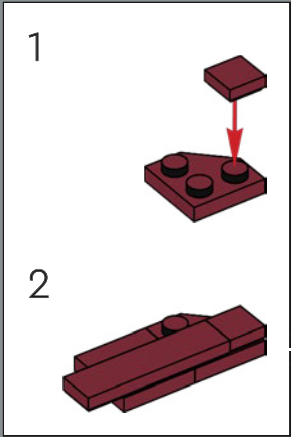



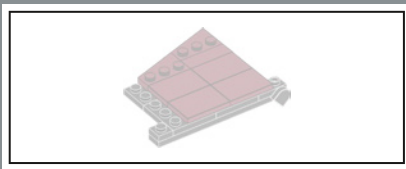

532

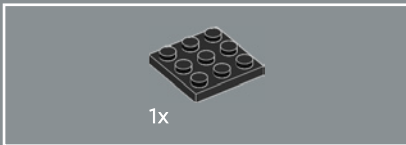

533

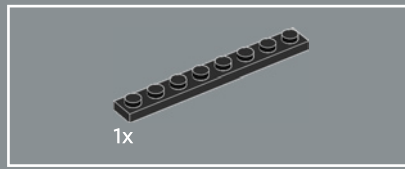
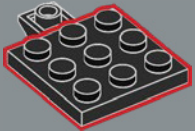

534

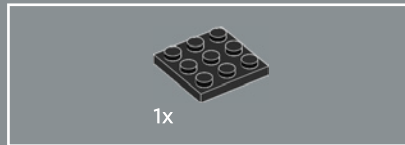
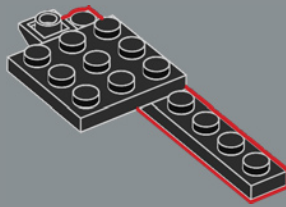

535

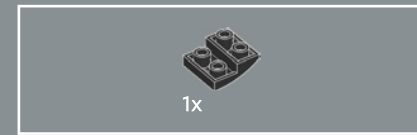
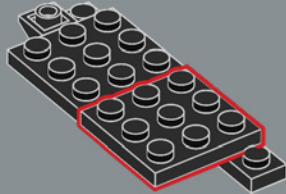

536

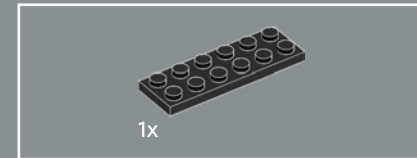
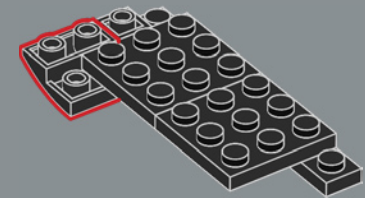

537

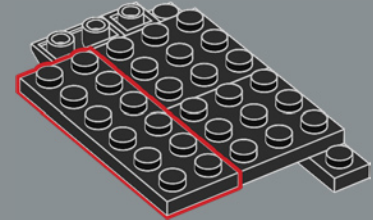



538

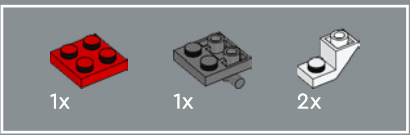
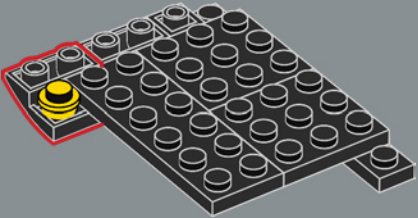

540

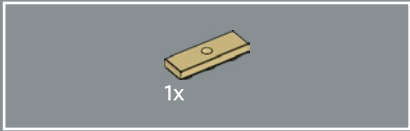
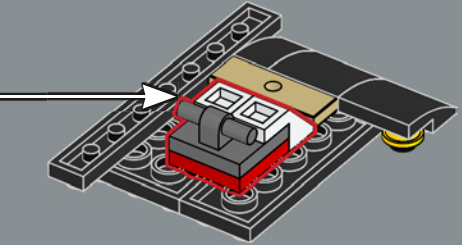
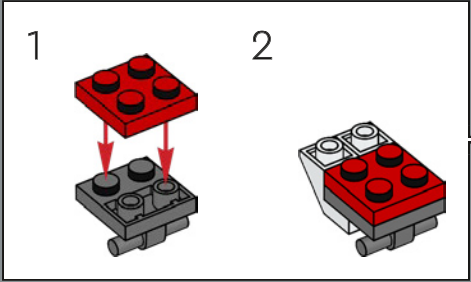

539

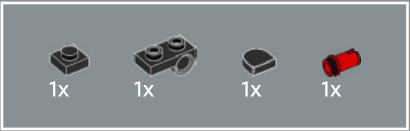
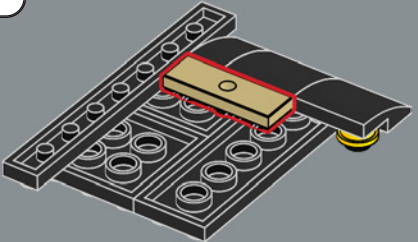

541

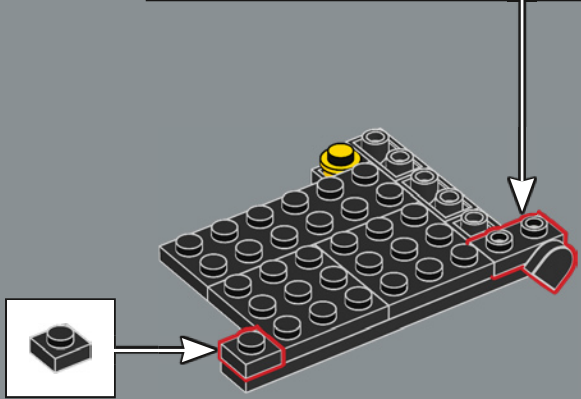
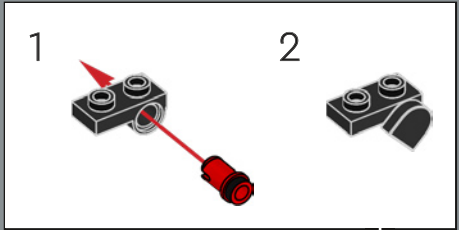

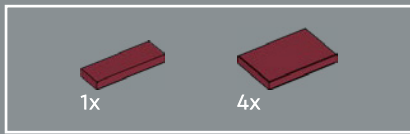

542

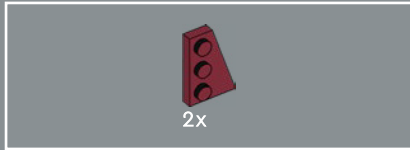
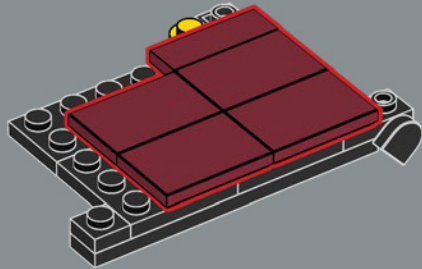

543

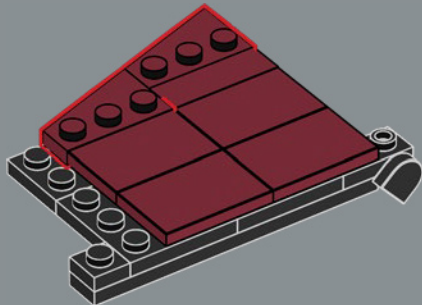

544

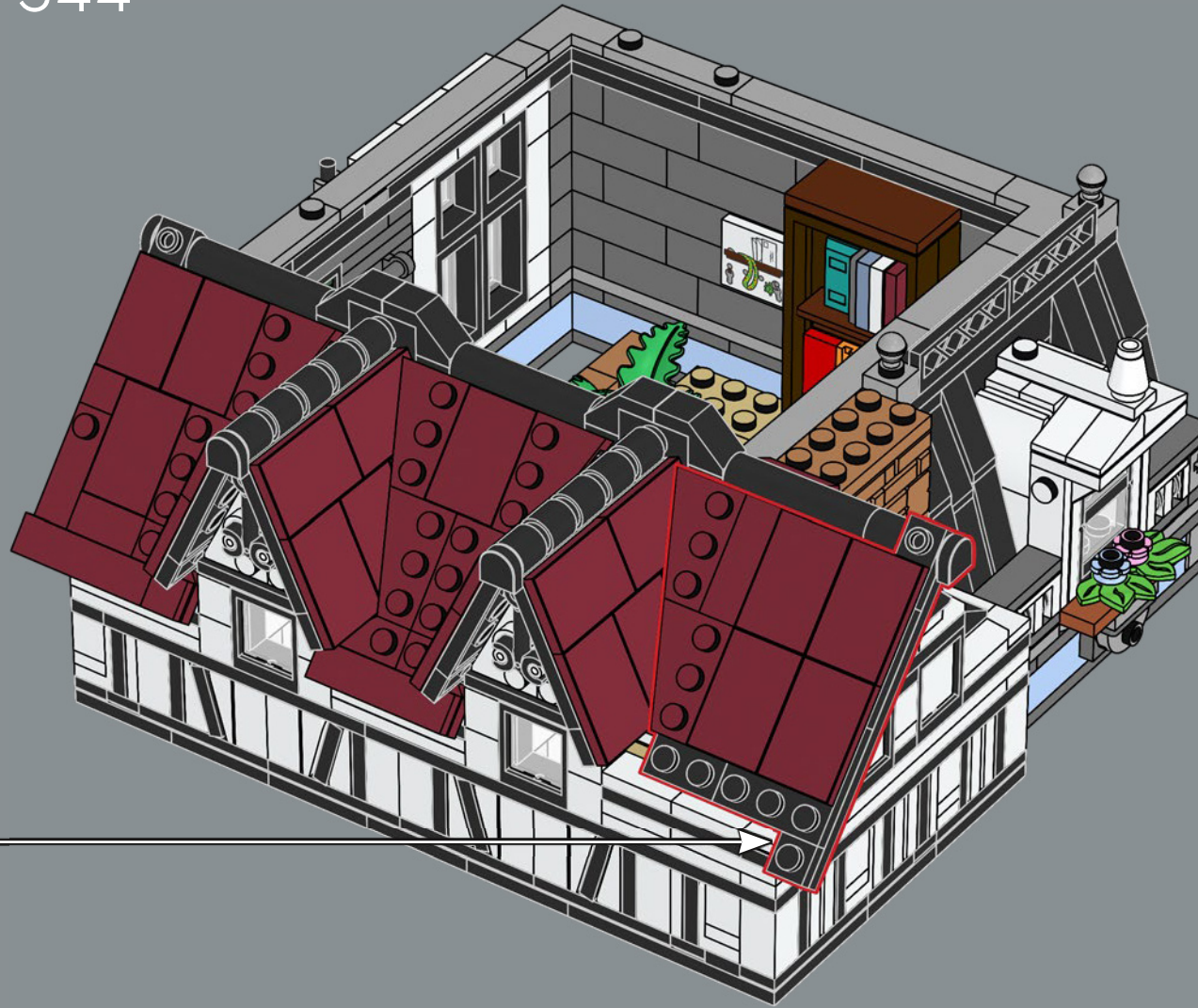

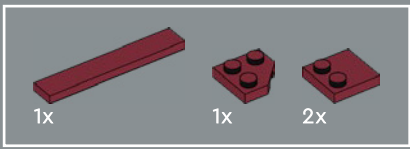

545

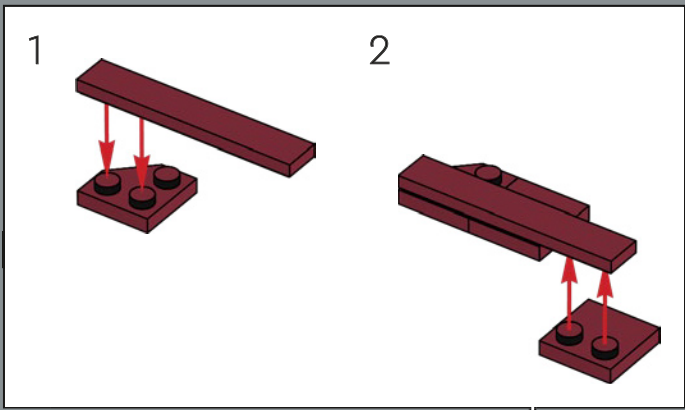
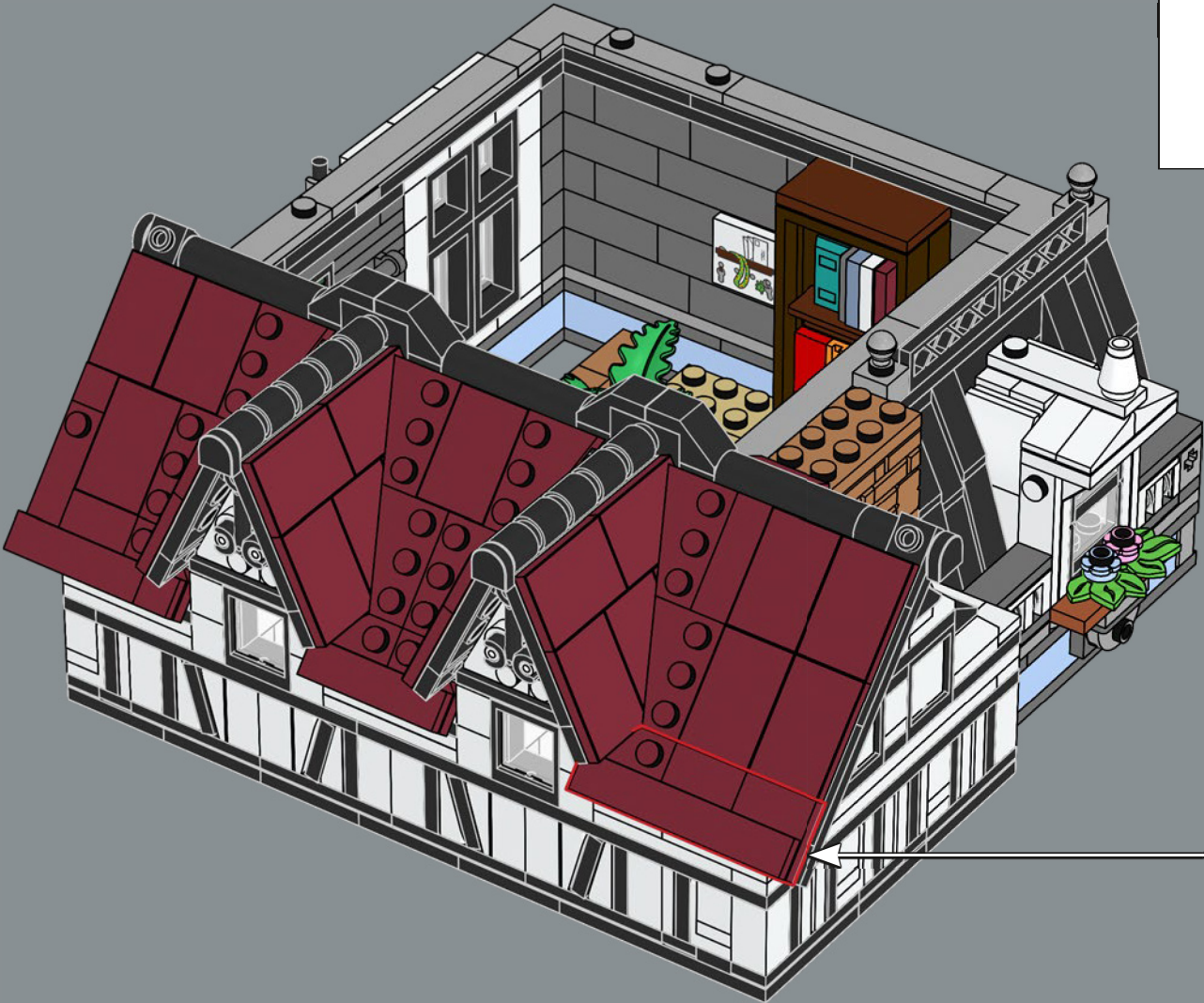

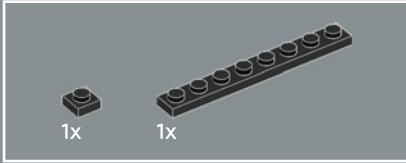
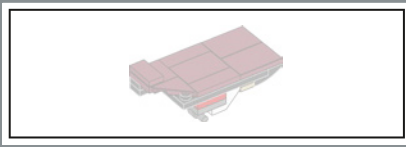

546

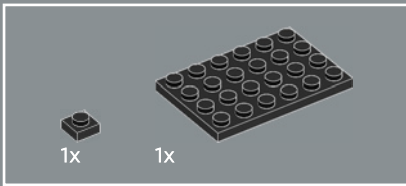
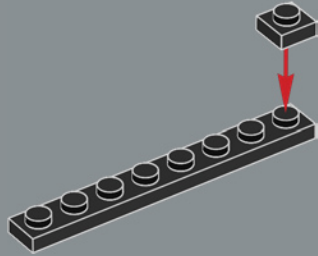

547

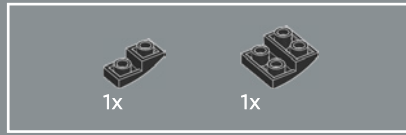
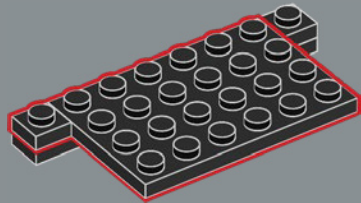

548

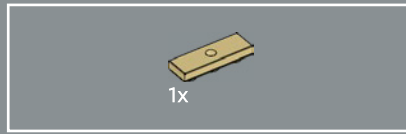
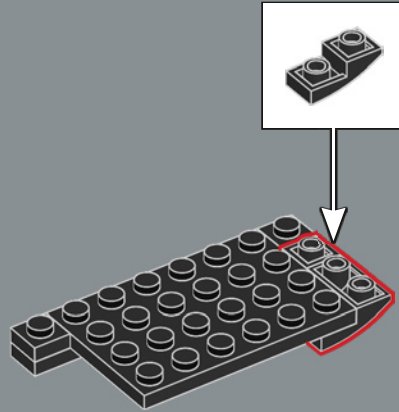

549

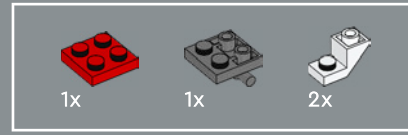
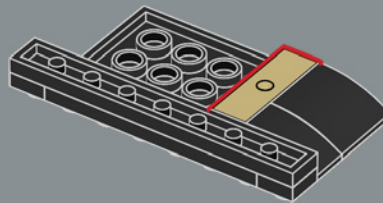

550

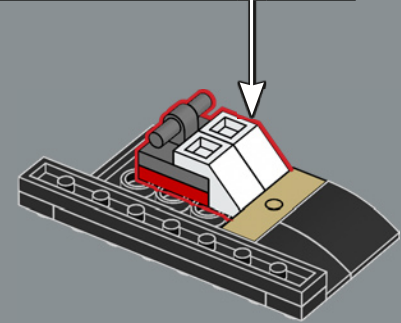
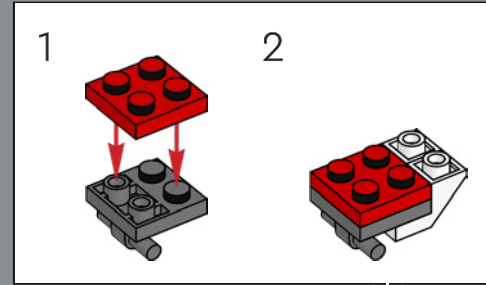

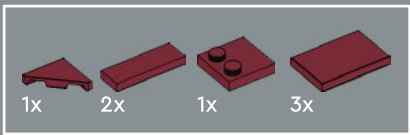

551

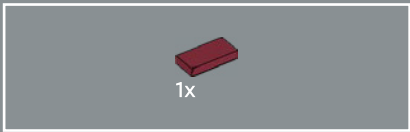
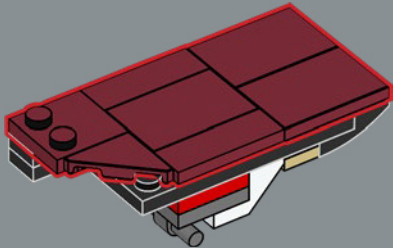

552

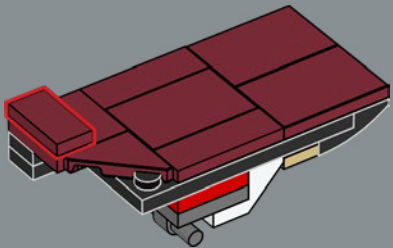

553

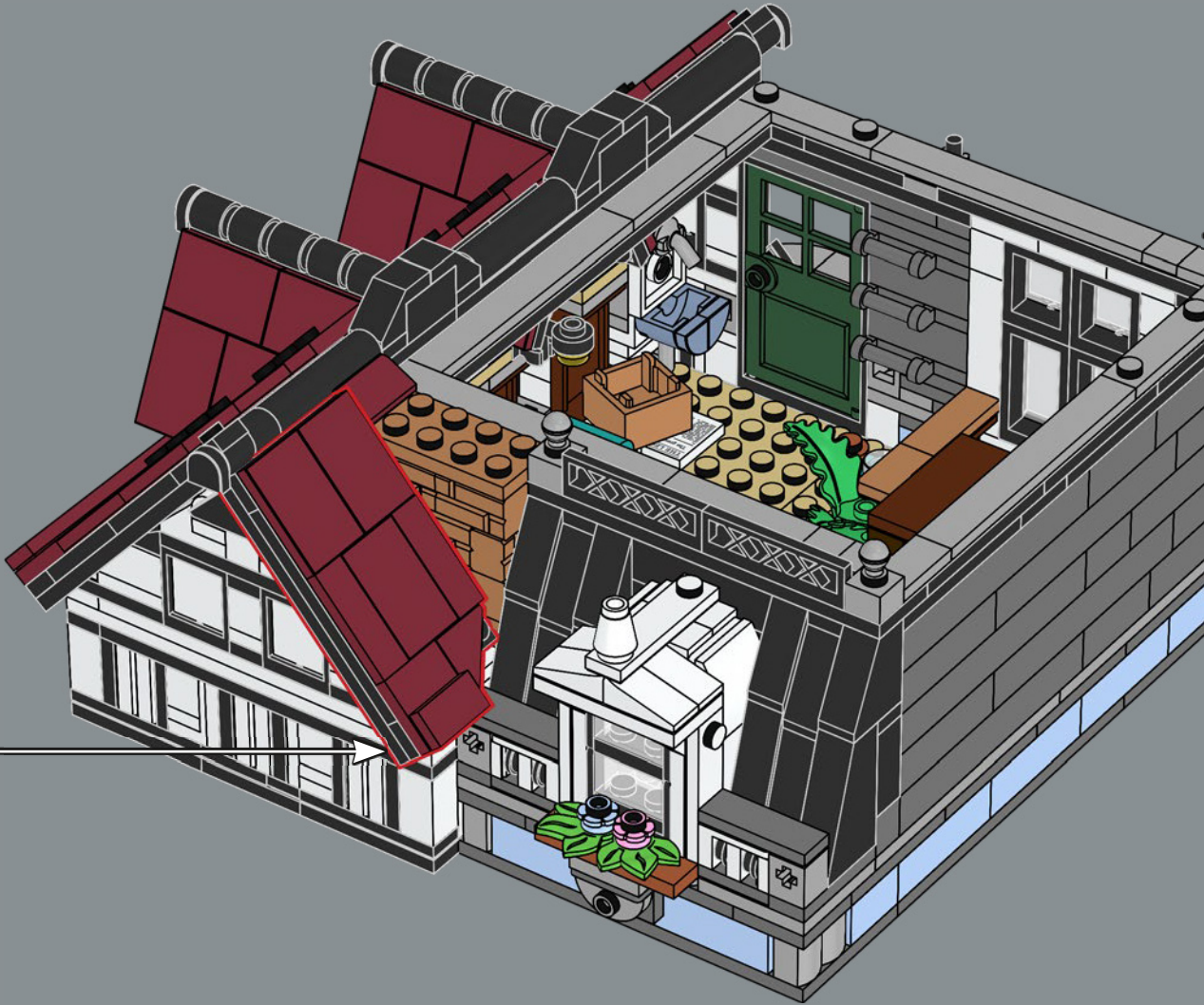

554

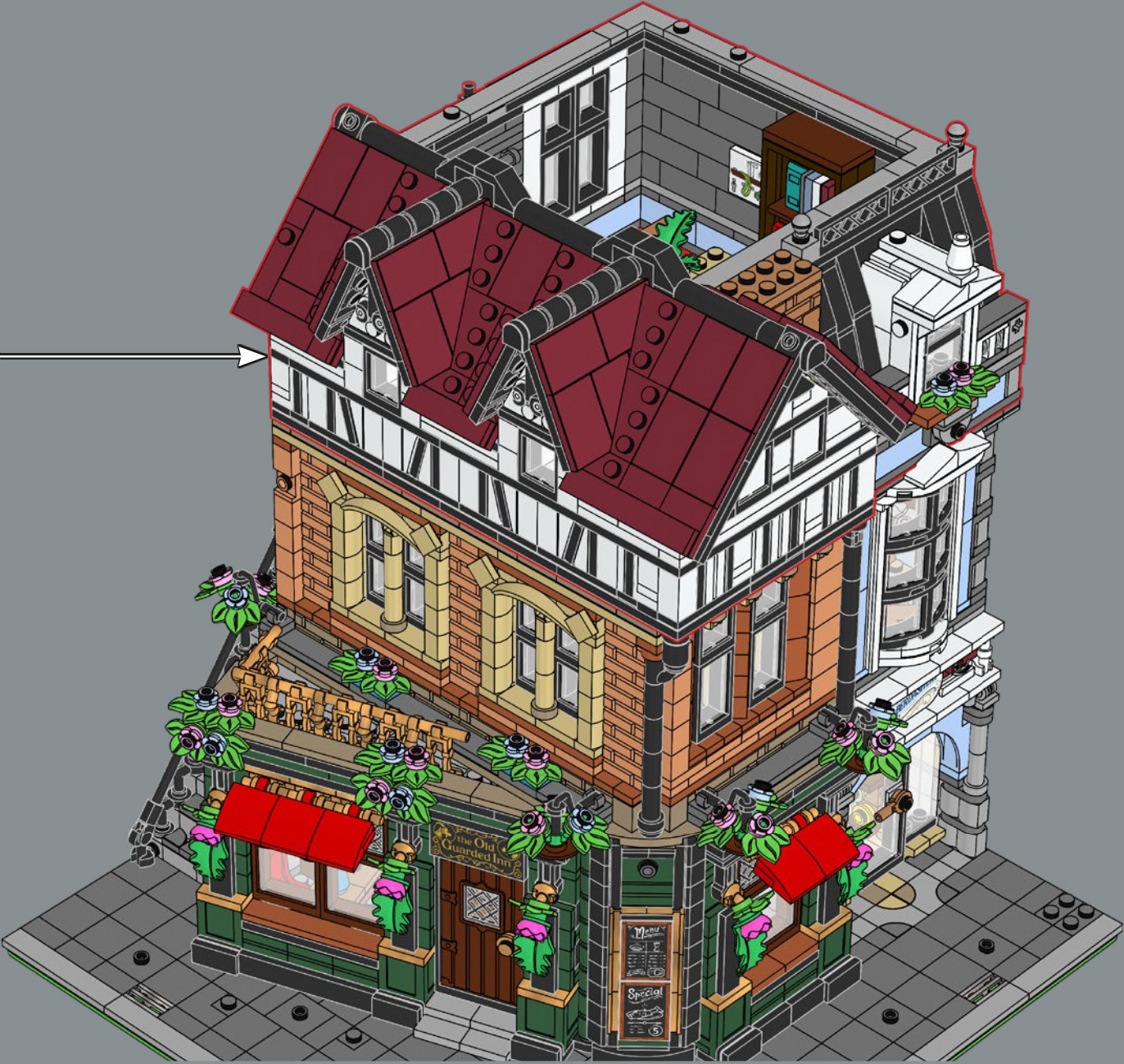

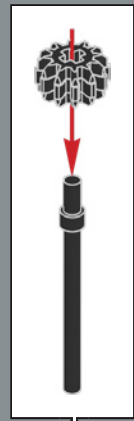
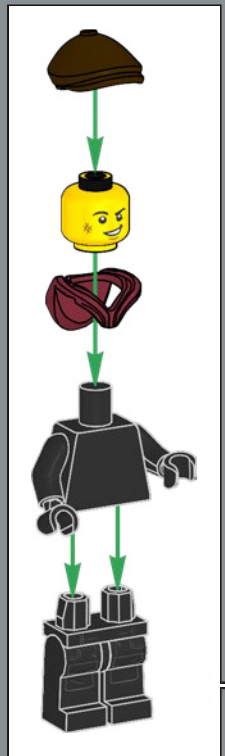
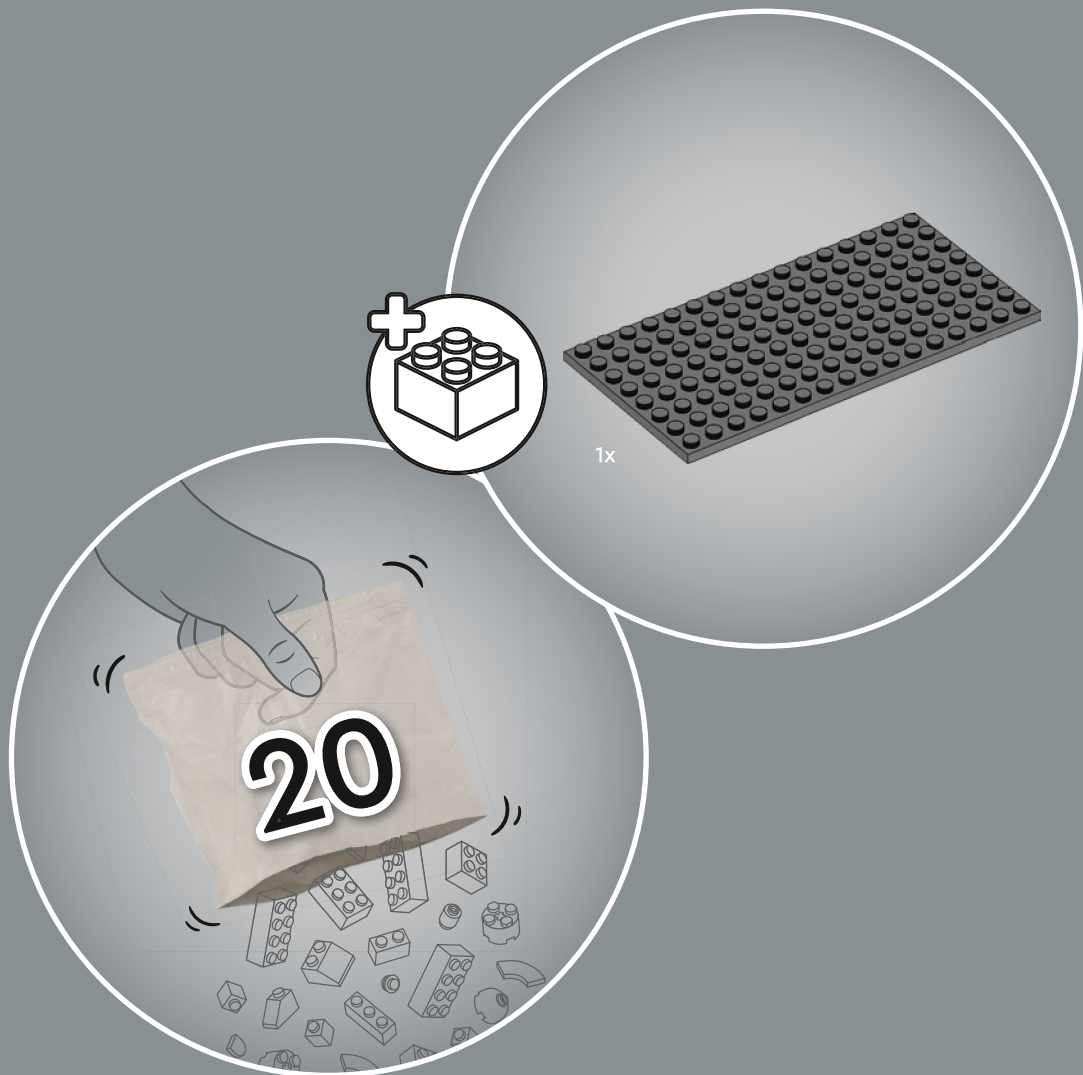



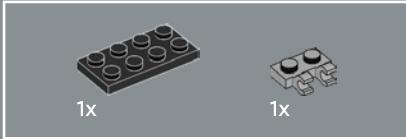
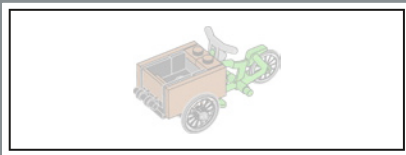

555

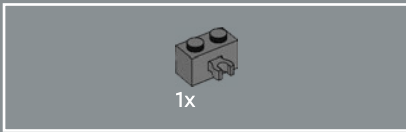
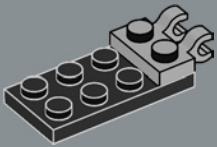

556

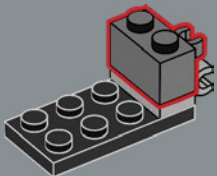

557

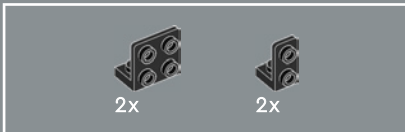
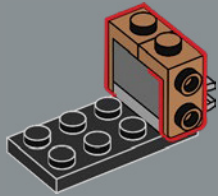

558

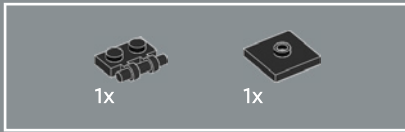
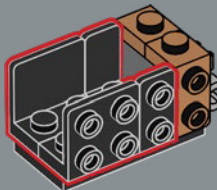

559

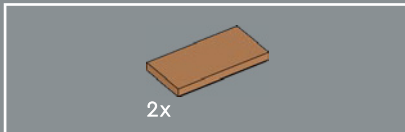
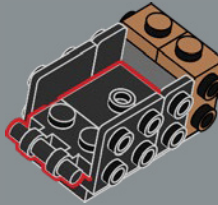

560

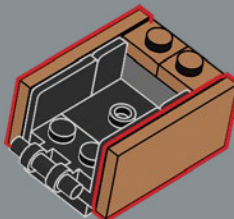



1x

561

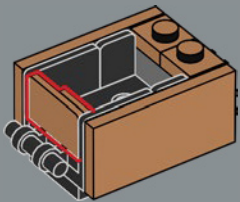

2x

563

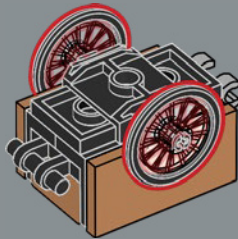

1x

565

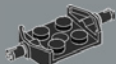
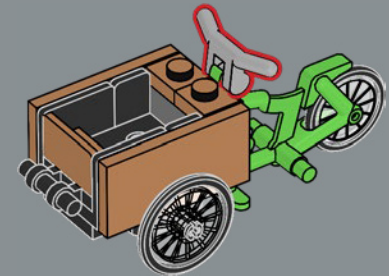

1x

562

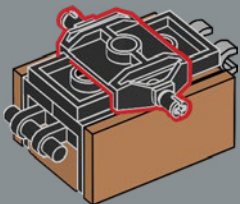

1x



1x

564

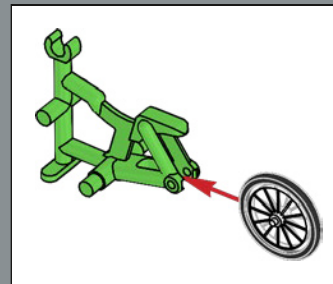
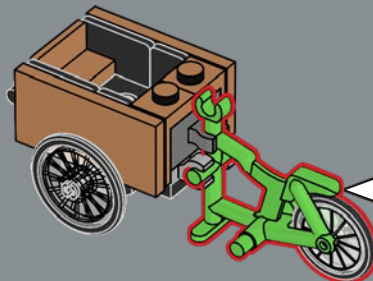

This cargo bike is perfect for getting around town and transporting your groceries, books or even your cats to the veterinarian above the LEGO® Creator Expert Corner Garage (10264).

Ce vélo cargo est parfait pour parcourir la ville et transporter les courses, les livres ou même les chats chez le vétérinaire au-dessus du garage du coin LEGO® Creator Expert (10264).

Esta bicicleta de carga es perfecta para moverse por la ciudad y transportar compras, libros o incluso gatos para llevarlos a la clínica de mascotas encima del Taller de la Esquina LEGO® Creator Expert (10264).

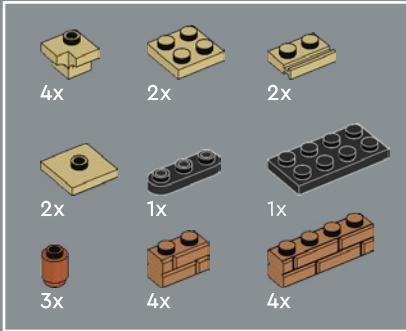
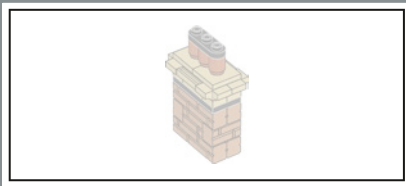

566

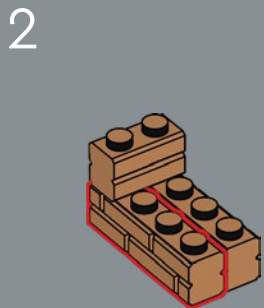
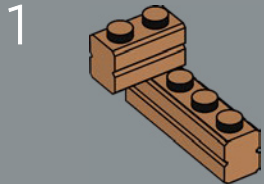

3

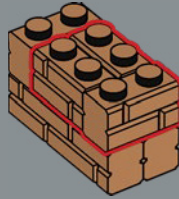

4

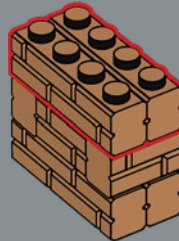

5

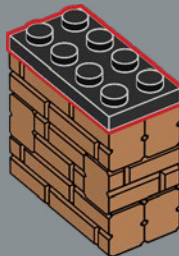

6

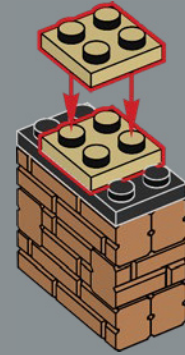

7

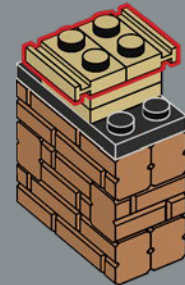

8

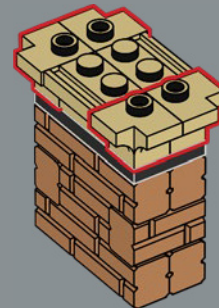

9

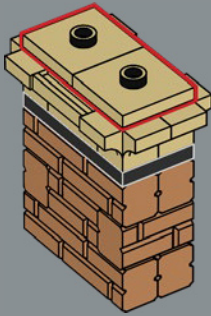

10

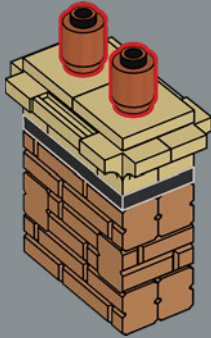

11

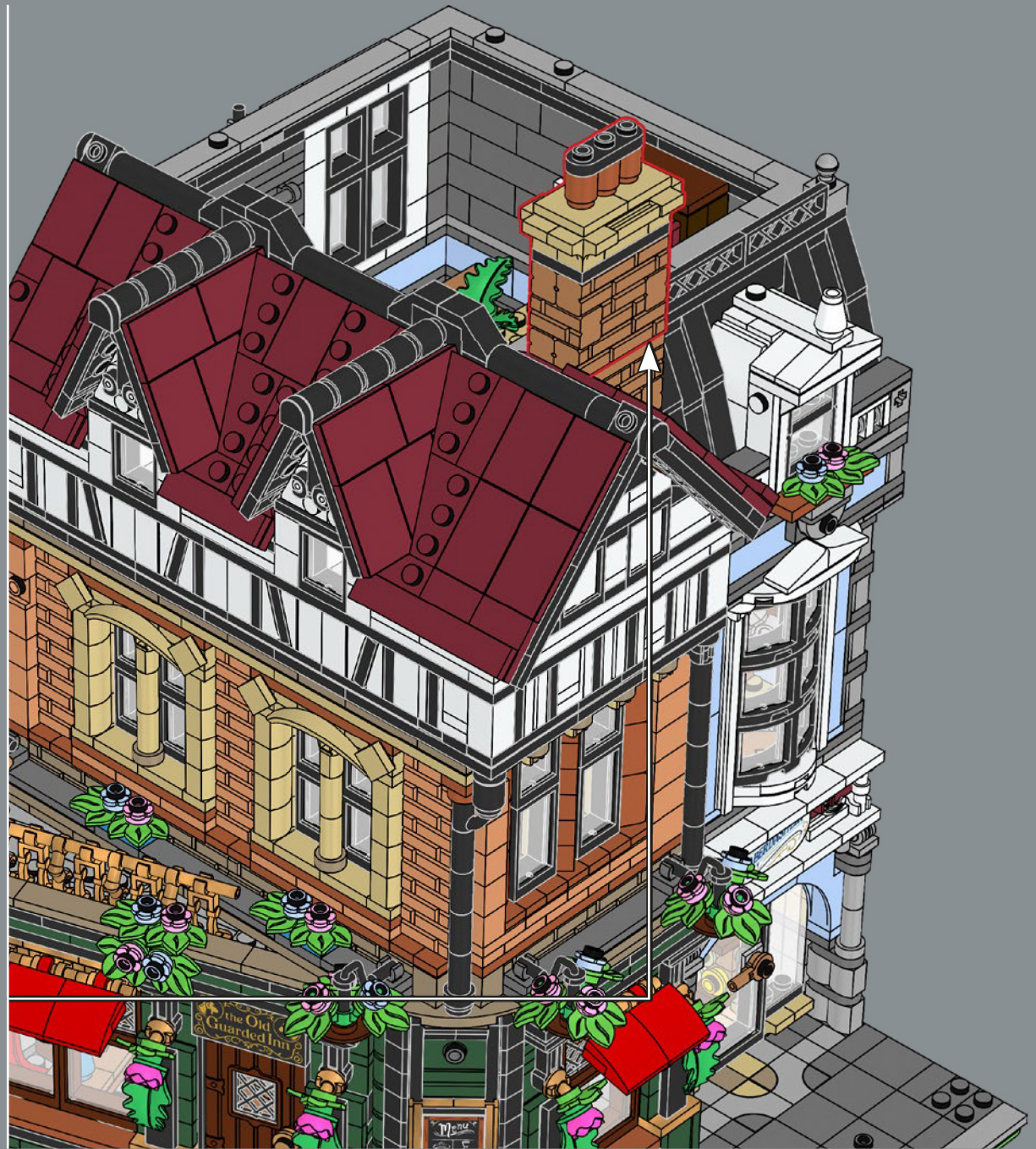
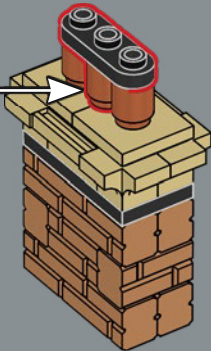
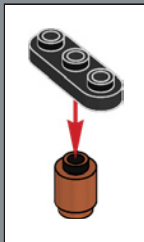

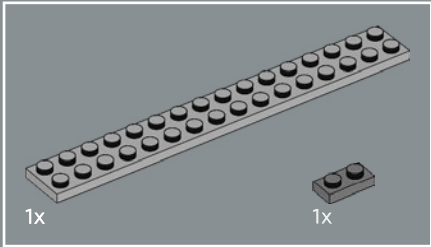
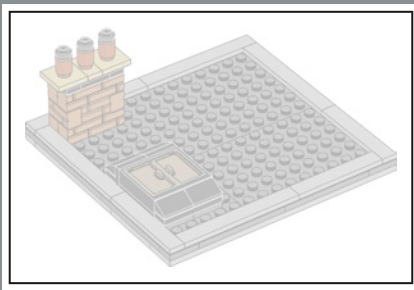

567

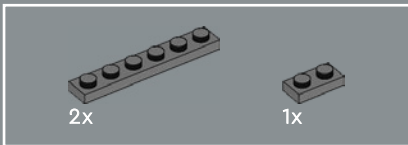
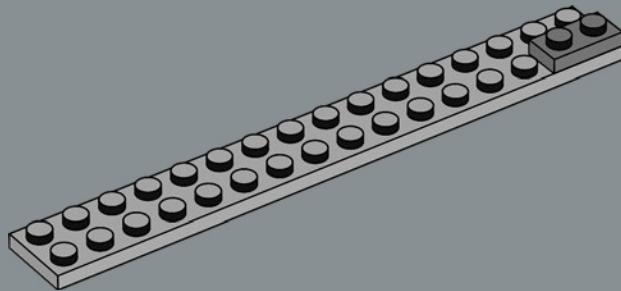

568

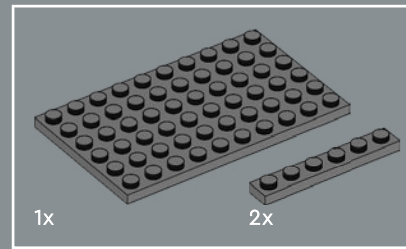
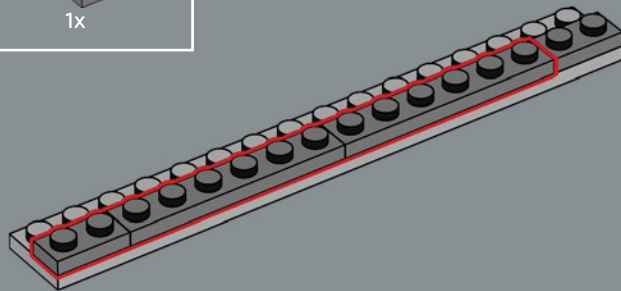

569

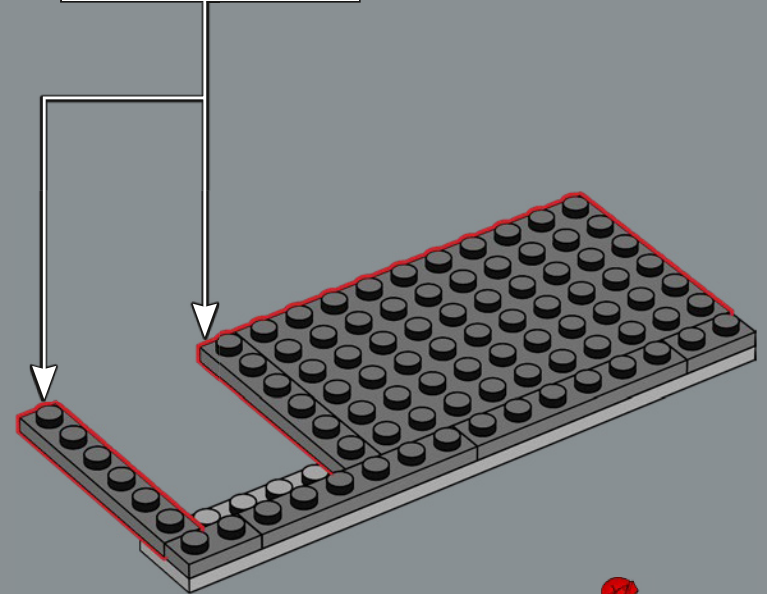
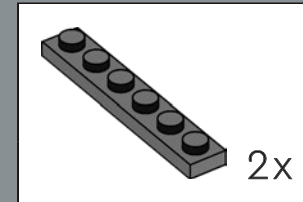

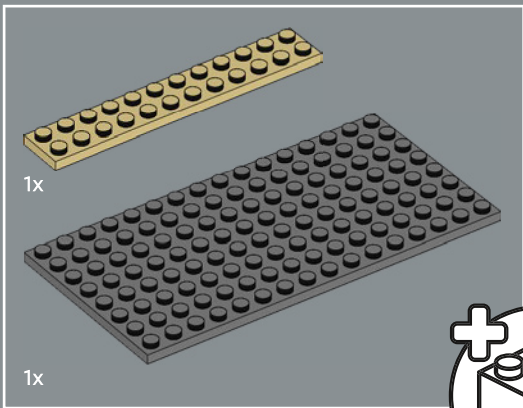

1x

1x

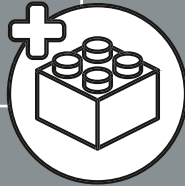

570

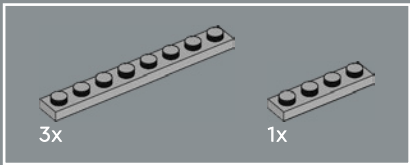
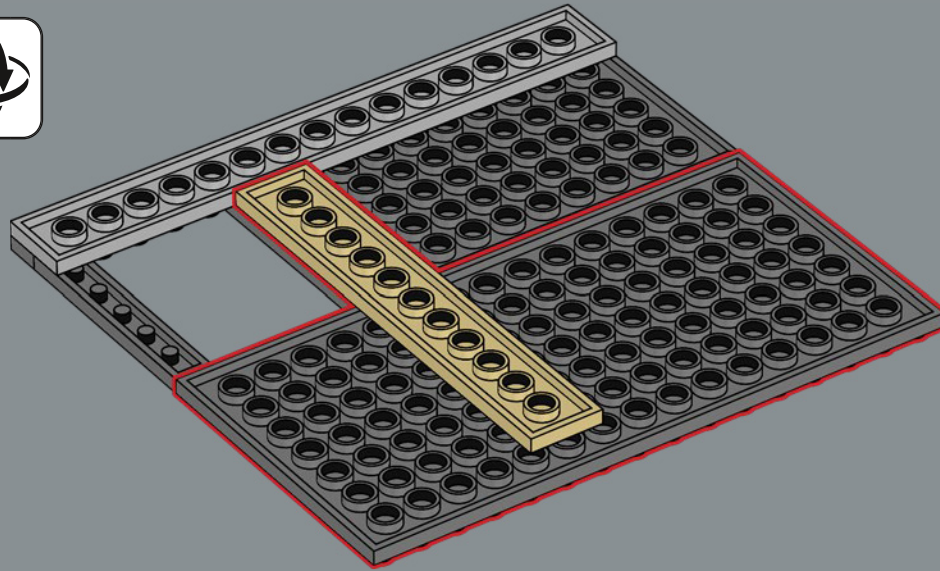

3x

1x

571

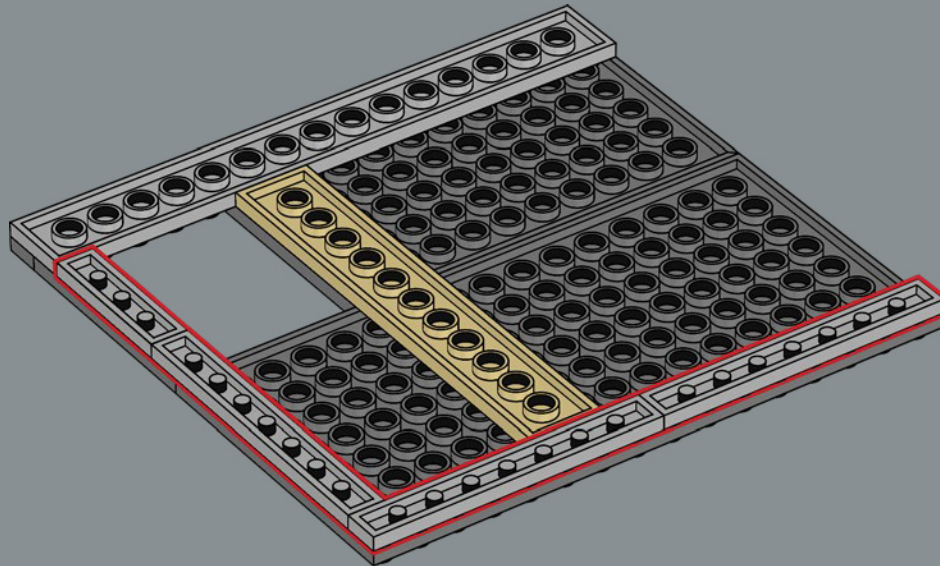

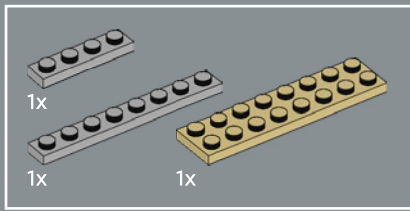

572

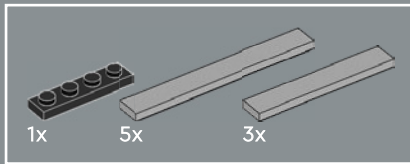
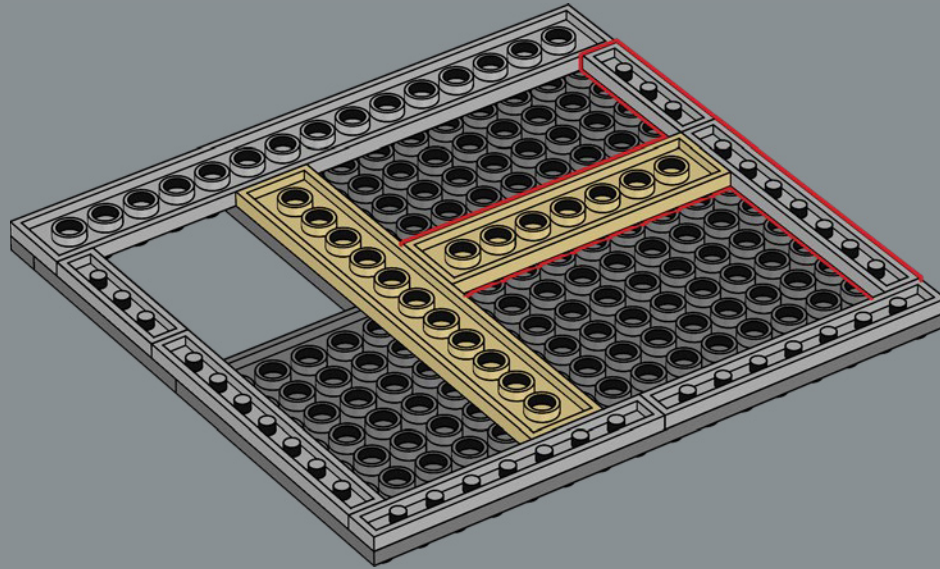

573

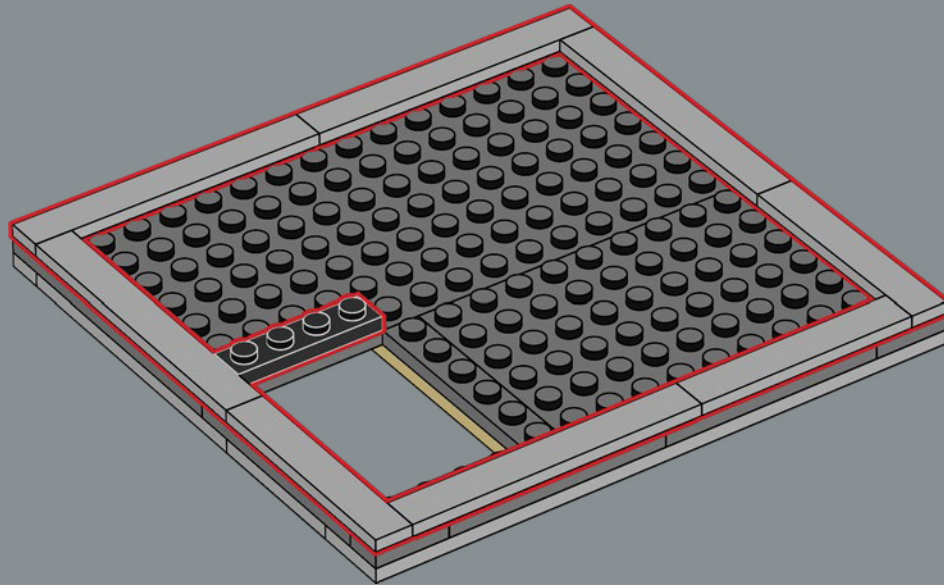

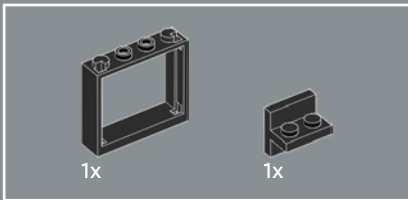
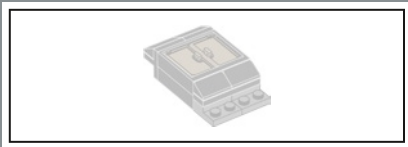

574

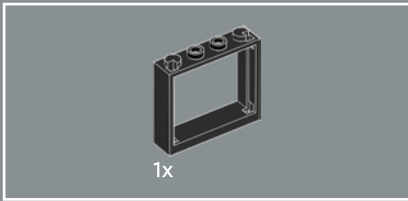
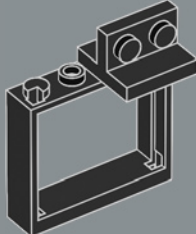

575

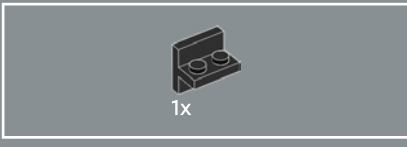
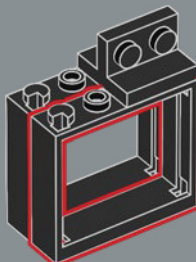

576

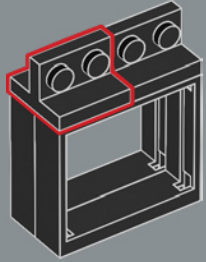

577

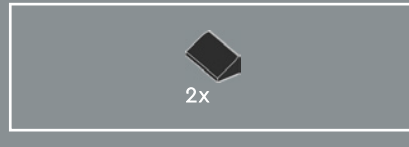
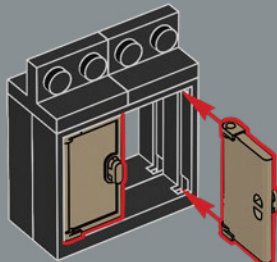

578

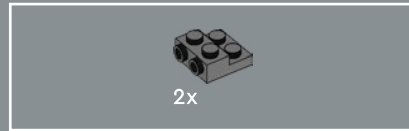
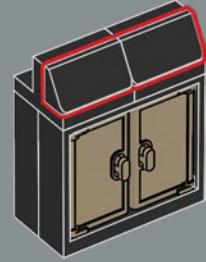

579

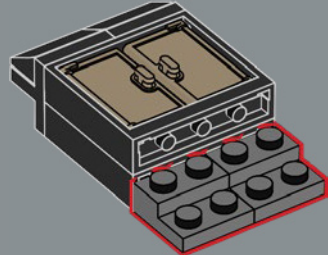



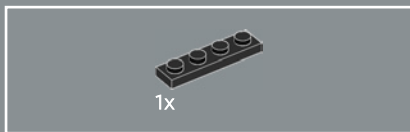

580

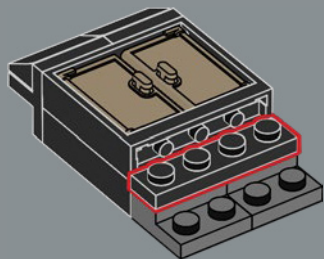

581

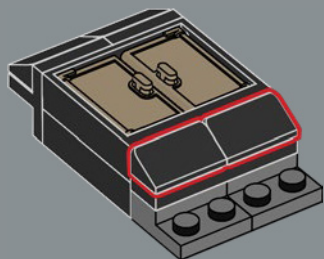

582

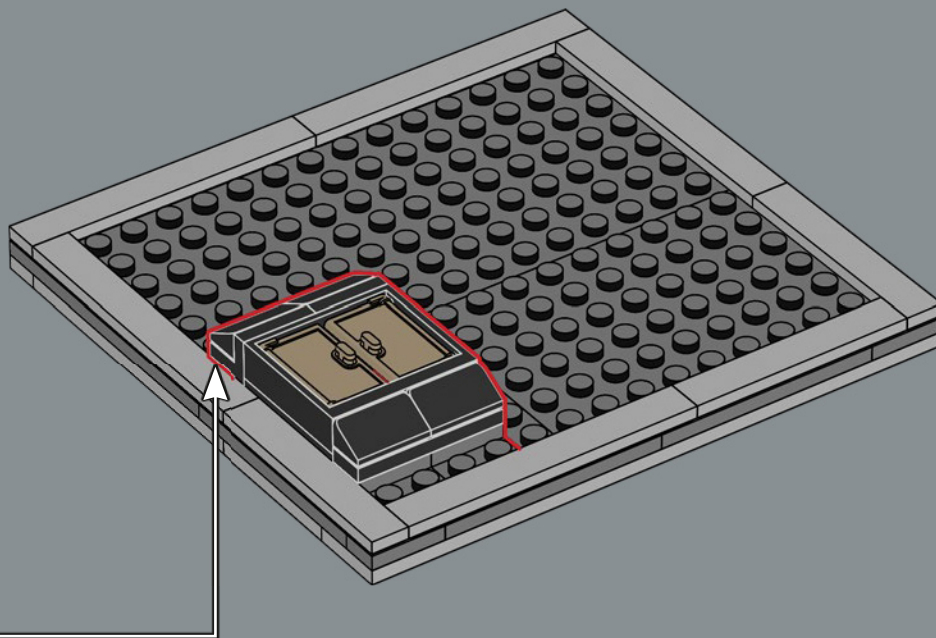

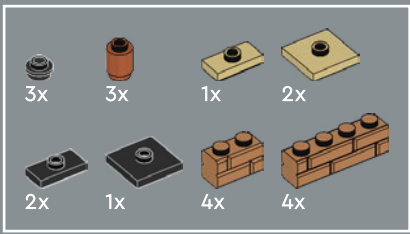

583

1

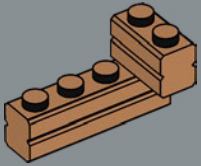

2

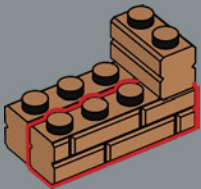

3

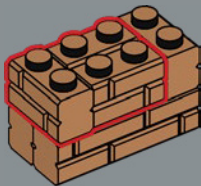

4

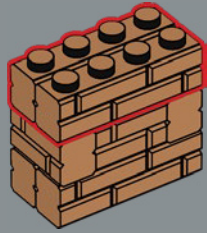

5

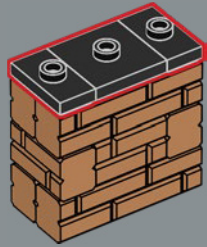

6

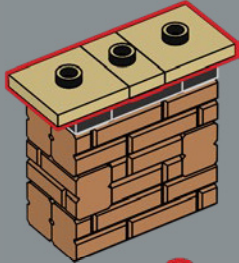

7

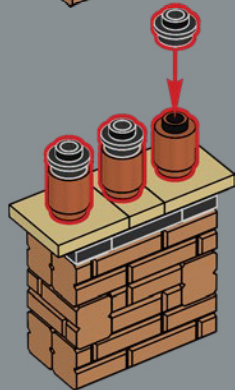

This chimney was condemned after the attic conversion work. It was nevertheless preserved for aesthetic reasons after a petition from the chimney sweep.

Cette cheminée a été condamnée après les travaux d'aménagement des combles. Elle a néanmoins été conservée pour des raisons esthétiques suite à une pétition du ramoneur.

Esta chimenea fue inutilizada después de las reformas del ático. Sin embargo, se conservó por razones estéticas a petición del limpiachimeneas.

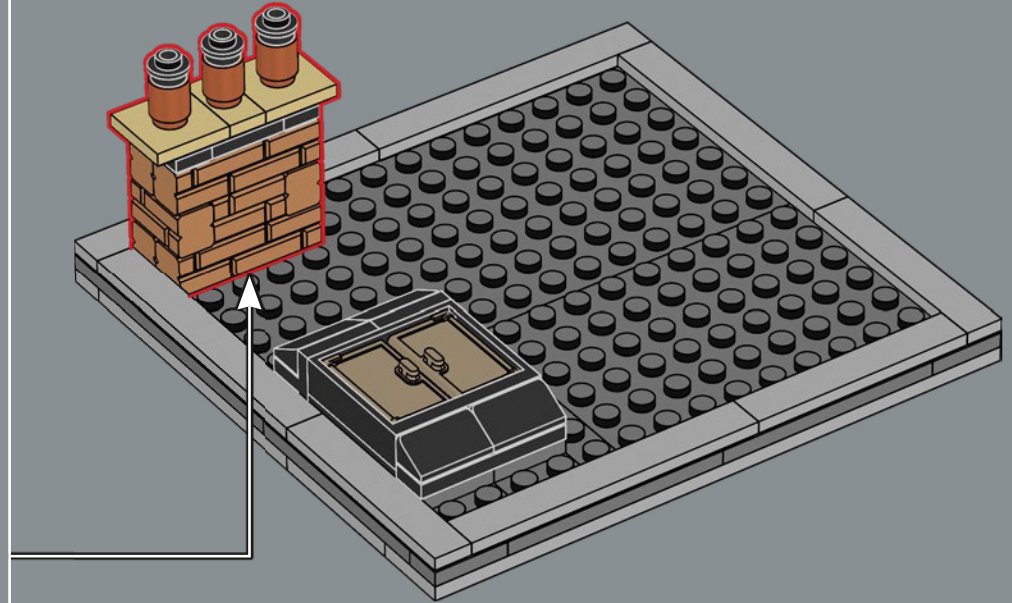

584



From the top, the chimney sweep enjoys a breathtaking view of the city's rooftops! All the beautiful buildings together make for quite a skyline!

Du haut de la cheminée, le ramoneur profite d'une vue imprenable sur les toits de la ville ! Tous ces beaux bâtiments forment une superbe ligne d'horizon !

Desde lo alto, el limpiachimeneas disfruta de una vista impresionante de los tejados de la ciudad. ¡Juntos, los hermosos edificios crean un horizonte espectacular!



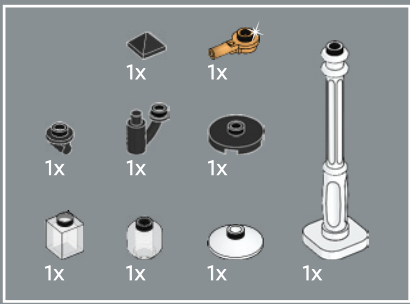

585

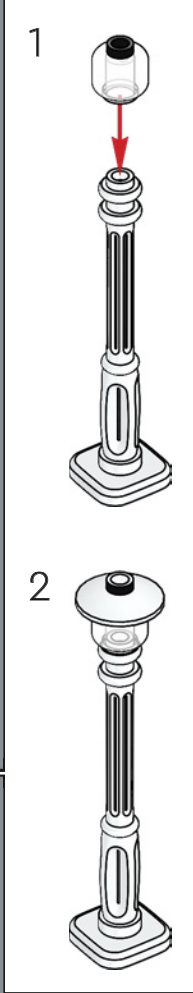
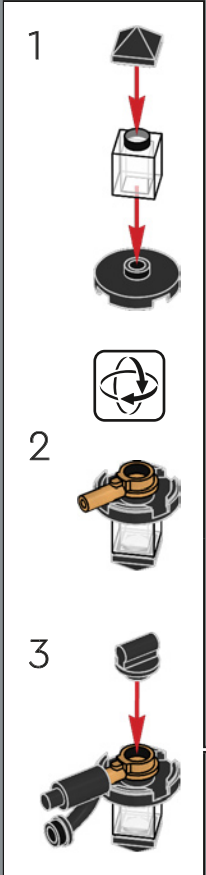



586



These bollards are in fact old cannons planted in the ground, trophies of a distant naval victory on the Sea Hawk from the LEGO® Pirates Caribbean Clipper (6274).

Ces bornes sont en fait de vieux canons plantés dans le sol, trophées d'une lointaine victoire navale sur le Sea Hawk du clipper des Caraïbes LEGO® Pirates (6274).

Estos bolardos son en realidad viejos cañones sembrados en el suelo, trofeos de una antigua victoria naval del Sea Hawk, del LEGO® Pirates Caribbean Clipper (6274).

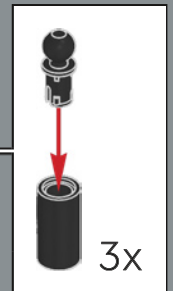

3x

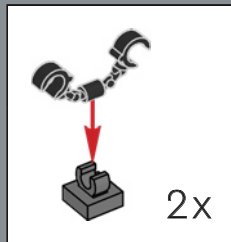

2x





587

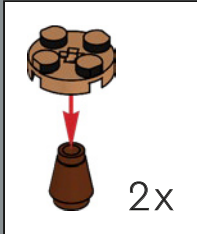
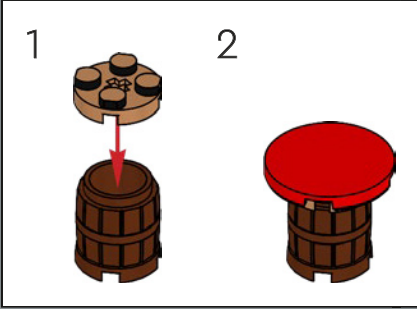

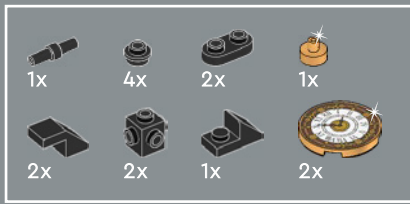

588

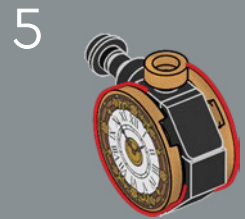
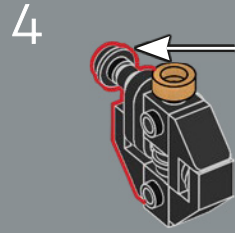
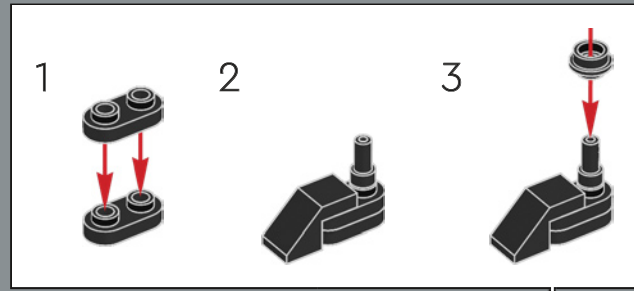
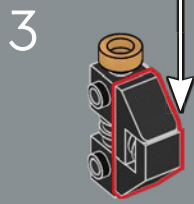
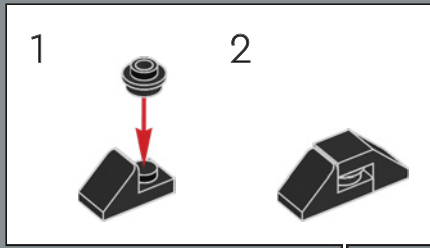
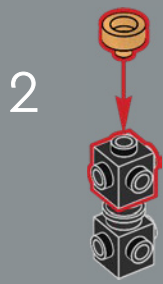
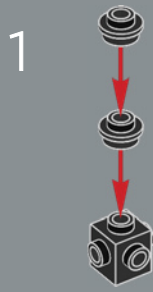

589



Hmm, the old clock is running a little late...  
The clockmaker can take care of it after  
his lunch break.

Hum, la vieille horloge est un peu en retard...  
L'horloger s'en occupera après sa pause dîner.

Hum, parece que el viejo reloj va un poco atrasado...  
El relojero se encargará de ajustarlo después de su  
descanso para comer.





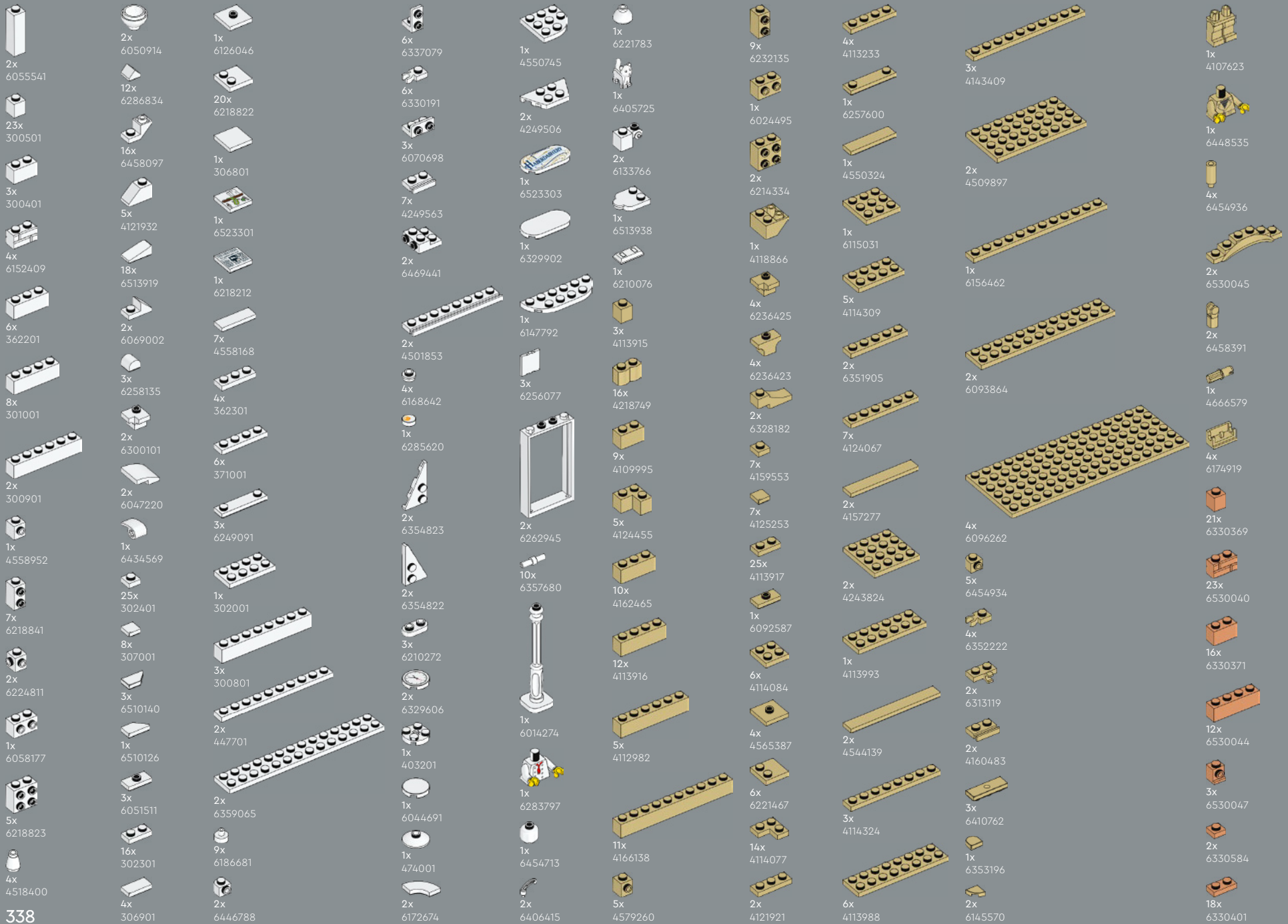



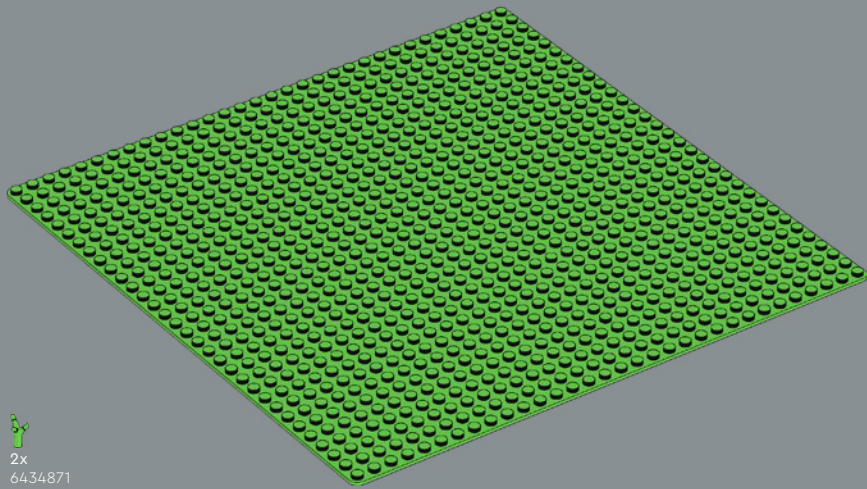

2x 6434871

4x 6235080

33x 6182261

1x 6513728

8x 6074890

8x 6374150

6x 6188477

4x 6517935

4x 6382577

3x 6143431

340

1x 6097276

1x 6186012

13x 6092602

9x 4570877

6x 6394948

1x 6186007

1x 6074892

1x 4535928

6x 6253418

1x 6359696

1x 6219673

15x 6315782

5x 6369194

1x 4616027

2x 6359041

1x 6172566

4x 6514262

2x 6251285

1x 6220959

1x 6254254

2x 6514052

2x 6532094

1x 6514191

21x 6254552

4x 6252258

1x 6514119

2x 6278710

1x 6514142

3x 6513992

1x 6507876

1x 6514192

1x 6514221

2x 6514056

2x 6514193

2x 6514234

1x 6245270

2x 6278710

1x 6514142

3x 6513992

1x 6507876

1x 6514192

1x 6514221

2x 6514056

2x 6514193

2x 6514234

1x 6245270

2x 6220715

1x 4125254

1x 6240515

1x 6278463

2x 6466044

1x 6210399

4x 6213779

2x 6422225

1x 6249390

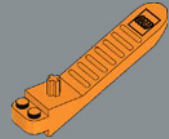

2x 6220715

1x 4125254

1x 6240515

1x 6278463

2x 6466044

1x 6210399

4x 6213779

2x 6422225

1x 6249390

1x 6350418

1x 6223065

4x 6513766

1x 6482693

1x 6210400

4x 6213876

1x 6494418

2x 6391344

1x 6190251

2x 6172869

12x 6138232

3x 6198156

2x 6400305

1x 6492725

1x 6202224

5x 6001824

1x 4646577

7x 6502374

3x 6055172

5x 4496699

3x 6126075

1x 6398654

1x 6047415

2x 4507045

2x 6015452

1x 6449594

8x 6328307

3x 6175927

5x 6257599

2x 4626904

2x 4267874

1x 6164288

2x 4507047

2x 4550329

5x 6395744

2x 6006524

1x 4251796

6x 6300320

6x 6330148

4x 6362967

1x 6449564

1x 6490609

1x 4570451

2x 6428821

1x 6335769

1x 6523305

2x 6446789

1x 4162916

4x 4521915

7x 6400283

8x 4245570

1x 4245571

16x 6252591

8x 6253282

6x 6530046

2x 4255624

9x 6055169

22x 6192250

26x 6013102

1x 6326011

3x 6186827

3x 4586057

7x 4245566

1x 6230571

2x 6314882

5x 6530042

1x 6454462

2x 4539099

1x 6083977

2x 4550169

2x 4539114

2x 4539097

4x 4539090

1x 4541506

1x 6288635

4x 6214309

3x 4583299

31x 6359681

4x 4539061

2x 4539060

1x 6257594

3x 4650865

2x 6359695

1x 6168645

4x 6267490

4x 6267492

4x 6210310

4x 4541496

1x 6443359

1x 6514005

1x 6514274

2x 6023173

2x 6236454

4x 6177699

3x 4211242

1x 6172808

3x 6201911

6x 4225469

1x 6325717

2x 4211183

2x 4529242

2x 4520612

1x 4504376

1x 6371437

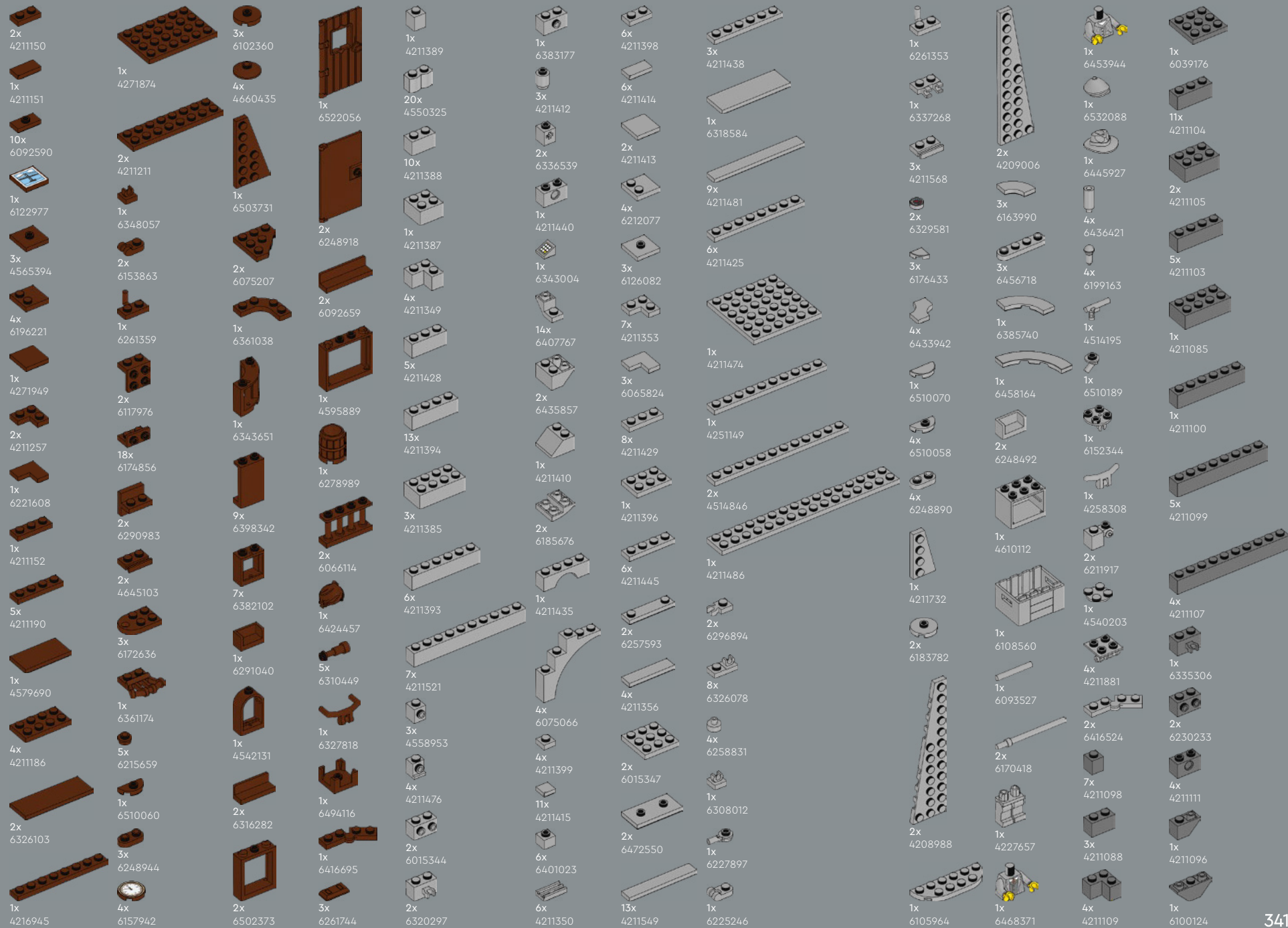

- 2x 4560184
- 1x 4211065
- 5x 42110651
- 5x 6257592
- 9x 4211056
- 1x 4211002
- 4x 4211115
- 1x 4257526
- 1x 4211114
- 1x 4211067
- 12x 6199549
- 20x 4210719
- 11x 4210848
- 1x 6092572
- 21x 4211063
- 47x 4211052
- 6x 6247784
- 1x 4211094
- 10x 6126083
- 7x 4210635
- 64x 4211055
- 12x 4211001
- 12x 4211133
- 6x 4568734
- 2x 4211043
- 7x 4211053
- 6x 6344022
- 8x 6435043
- 2x 6413106
- 3x 6000606
- 2x 6250018
- 3x 6146321
- 4x 6457961
- 3x 6313189
- 2x 6469463
- 1x 4595710
- 8x 6221607
- 1x 4210759
- 1x 4210811
- 1x 6395635
- 2x 4211122
- 1x 4654613
- 6x 6285271
- 13x 6100322
- 20x 6182777
- 50x 6287903
- 4x 6383074
- 4x 6361990
- 2x 6387467
- 1x 4210759
- 1x 4210811
- 1x 6395635
- 2x 4211122
- 1x 4654613
- 6x 6285271
- 13x 6100322
- 20x 6182777
- 50x 6287903
- 4x 6383074
- 4x 6361990
- 2x 6387467
- 2x 4595708
- 1x 6435762
- 8x 6362254
- 2x 6372225
- 3x 6361988
- 10x 6184484
- 12x 6209683
- 3x 6132418
- 3x 6361985
- 1x 6132422
- 1x 6228091
- 1x 6230582
- 5x 6513737
- 6x 6330199
- 8x 6275872
- 16x 6212501
- 2x 6359834
- 1x 4523159
- 7x 6372427
- 2x 6190252
- 2x 6523304
- 5x 6209691
- 2x 6093529
- 1x 6147169
- 6x 6523396
- 6x 6530041
- 1x 6292254
- 1x 6132266
- 1x 6034543
- 5x 6508090
- 9x 6186672
- 1x 6262138
- 6x 6445925
- 12x 6338242
- 5x 6279731
- 2x 6378168
- 2x 6328909
- 5x 6501270
- 4x 6443652
- 7x 6516867
- 2x 6404033
- 1x 6179803
- 14x 6347604
- 3x 4623298
- 4x 6492338
- 2x 6272143
- 1x 6337282
- 1x 6436364
- 1x 6372359
- 1x 6501311
- 3x 4538950
- 1x 6313874
- 12x 4651231
- 14x 6346783
- 9x 6055309
- 5x 6135191
- 3x 6431328
- 9x 6215606
- 10x 6177146
- 8x 6292154
- 16x 6021997
- 2x 6445925
- 3x 6102990
- 2x 6349274
- 1x 6102994
- 1x 6365746
- 2x 6167700
- 31x 6102998
- 2x 6218359
- 1x 6343854
- 1x 6295464
- 1x 6313600
- 2x 6474266
- 1x 6433634
- 1x 6248536
- 3x 6167643
- 1x 6226646
- 2x 6356640
- 2x 6417964
- 4x 4619636
- 1x 6329604
- 1x 6096993
- 1x 6363150
- 1x 4624615
- 1x 6338570
- 2x 6404754
- 4x 4653988
- 2x 6060857
- 1x 6126090
- 1x 6136419
- 1x 6354763
- 2x 6209673
- 1x 6256092
- 1x 6291414



 [LEGO.com/service](https://www.LEGO.com/service)



# YOU COULD WIN



## YOU COULD WIN

Your feedback will help shape the future development of this product series.

Visit:

## DU KÖNNTEST GEWINNEN

Dein Feedback trägt zur Weiterentwicklung dieser Produktreihe bei.

Geh auf:

## VOUS POURRIEZ GAGNER

Vos commentaires nous aideront à concevoir les futurs produits de cette gamme.

Visitez :

## POTRESTI VINCERE TU

La tua opinione ci aiuterà a migliorare la creazione futura di questa linea di prodotti.

Visita:

## PUEDES GANAR

Tu opinión contribuirá al futuro de esta serie de productos.

Visita:

## 轻松获奖

您的反馈将有助于我们在今后改进本产品系列。

请访问:

---

[LEGO.com/productfeedback](https://www.lego.com/productfeedback)

---

You also have the chance to win a LEGO® set.

Terms and conditions apply.\*

Außerdem hast du die Chance, ein LEGO® Set zu gewinnen.

Es gelten die Teilnahmebedingungen.\*

Vous pourriez également gagner un ensemble LEGO®.

Des conditions s'appliquent.\*

Hai anche la possibilità di vincere un set LEGO®.

Termini e condizioni sono applicabili.\*

También tienes la oportunidad de ganar un set LEGO®.

Aplican términos y condiciones.\*

您还有机会赢取乐高®套装。

条款和条件适用。\*

\*[LEGO.com/productfeedback-terms](https://www.lego.com/productfeedback-terms)

