



10341



Booklet available in English on  
Livret disponible en français sur  
Folleto disponible en español en



LEGO® Builder

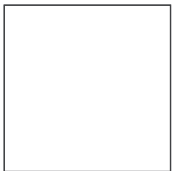



## WE'RE MAKING OUR PACKAGING MORE SUSTAINABLE

We're transitioning from single-use plastic to paper-based packaging. As we progress, you may find a mix of paper and plastic in our boxes.

## NOUS RENDONS NOS EMBALLAGES PLUS DURABLES

Nous passons des emballages en plastique à usage unique aux emballages à base de papier. Durant la transition, vous pourriez trouver un mélange de papier et de plastique dans nos boîtes.

## QUEREMOS HACER MÁS SUSTENTABLES NUESTROS MATERIALES DE EMBALAJE

Estamos cambiando las bolsas de plástico desechables por bolsas con base de papel. Conforme avanzamos en este propósito, puedes encontrar una mezcla de papel y de plástico en nuestras cajas.

[LEGO.com/sustainable-packaging](https://LEGO.com/sustainable-packaging)



# BUILDER



Apple and the Apple logo are trademarks of Apple Inc., registered in the U.S. and other countries and regions. App Store is a service mark of Apple Inc. Google Play and the Google Play logo are trademarks of Google LLC. Tencent and the Tencent logo are trademarks of Tencent Inc.

LEGO.com/devicecheck



LEGO® Builder



## A MATCH MADE IN SPACE

Our most important LEGO® mission is to inspire the builders of tomorrow. And why settle for the sky if we can push our limits into space? For more than 50 years, NASA has inspired new generations of creative, brave and ground-breaking explorers. Now, with the first Artemis mission successfully completed (in 2022), and more to follow in years to come, NASA returns to the Moon to establish a long-term human presence and scientific exploration on and in the orbit of the Moon. To begin this journey of discovery, NASA, in collaboration with international space agencies and experts in the field, has spearheaded the Space Launch System (SLS) and Orion spacecraft – their most powerful rocket and most capable spacecraft to date. Inspired by NASA's Artemis Block 1 rocket with the Orion spacecraft, this model replicates authentic details to land you in the front seat to as many imaginary rocket launches and thrilling space missions as you can imagine. Get ready to build your way to the Moon and beyond.

## EN ROUTE VERS L'ESPACE

La mission la plus importante de LEGO® est d'inspirer les constructeurs de demain. Et pourquoi garder les pieds sur terre si nous pouvons repousser nos limites jusque dans l'espace ? Depuis plus de 50 ans, la NASA inspire de nouvelles générations d'explorateurs créatifs, courageux et novateurs. Avec la première mission Artemis achevée avec succès (en 2022) et d'autres qui suivront dans les années à venir, la NASA retourne maintenant sur la Lune pour établir une présence humaine à long terme et une exploration scientifique sur sa surface et dans son orbite. Pour entamer ce voyage de découverte, la NASA, en collaboration avec des agences spatiales internationales et des experts du domaine, a mis au point le système de lancement spatial (SLS) et le vaisseau spatial Orion, sa fusée la plus puissante et son vaisseau spatial le plus performant à ce jour. Inspiré par la fusée Artemis Block 1 et le vaisseau spatial Orion de la NASA, ce modèle reproduit des détails authentiques pour vous permettre d'être aux premières loges d'autant de lancements de fusées et de missions spatiales palpitantes que vous pouvez imaginer. Préparez-vous à construire votre voie vers la Lune et au-delà.

## UNA COLABORACIÓN ESTELAR

La misión más importante de LEGO® es inspirar a los constructores del mañana. ¿Y por qué habríamos de conformarnos con el cielo, si podemos llevar nuestros límites al espacio exterior? Durante más de 50 años, la NASA ha inspirado a nuevas generaciones de exploradores creativos, valientes e innovadores. Y ahora que se ha completado con éxito la primera misión del programa Artemis (en 2022) y se tienen previstas otras más para los próximos años, la NASA regresa a la Luna para establecer una presencia humana de largo plazo en su superficie y su órbita con fines de exploración científica. Para iniciar este viaje de descubrimiento, la NASA, en colaboración con agencias espaciales internacionales y expertos en la materia, ha creado el sistema de lanzamiento espacial (SLS) y la nave Orion, su cohete más potente y su nave espacial más capaz hasta la fecha. Inspirado en el cohete SLS Block 1 con la nave espacial Orion de la misión Artemis I de la NASA, este modelo reproduce detalles auténticos para que ocupes tu lugar en el asiento del capitán de tantos lanzamientos y misiones espaciales como puedas imaginar. Prepárate para construir el vehículo que te llevará a la Luna y más allá.



## ▼ HISTORY IN THE MAKING

As part of the Artemis missions, NASA will land the first woman and first person of color on the Moon.

At 8,818,490 lbs. (4 million kg) of thrust, the NASA SLS is the most powerful rocket built to date.

The Orion spacecraft traveled 42,874.6 miles (69,000 km) beyond the Moon during the Artemis I mission, farther than any other spacecraft built for humans.

## ▼ L'HISTOIRE EN ÉVOLUTION

Dans le cadre des missions Artemis, la NASA fera atterrir la première femme et la première personne de couleur sur la Lune.

Avec une poussée de 4 millions de kilos, le SLS de la NASA est le lanceur le plus puissant construit à ce jour.

Le vaisseau spatial Orion a parcouru 69 000 km au-delà de la Lune lors de la mission Artemis I, plus loin que tout autre vaisseau spatial construit pour les humains.

## ▼ HACIENDO HISTORIA

Como parte de las misiones Artemis, la NASA hará aterrizar en la Luna a la primera mujer y a la primera persona de color.

Con 4.000.000 kg de empuje, el cohete SLS de la NASA es el más potente construido hasta la fecha.

La nave espacial Orion viajó 69.000 km más allá de la Luna durante la misión Artemis I, más lejos que cualquier otra nave espacial construida para una tripulación humana.

# THE ARTEMIS I JOURNEY

## LA MISSION ARTEMIS I

### MISIÓN ARTEMIS I: EL VIAJE

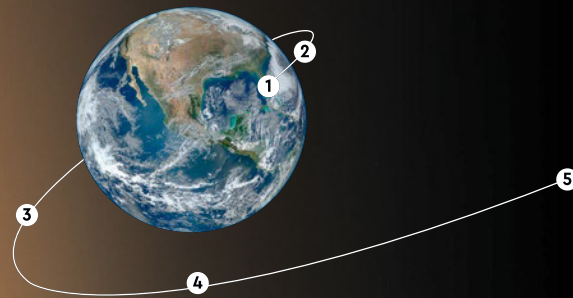

#### 1 LIFTOFF

To overcome the pull of Earth's gravity, the NASA SLS produced nearly 8,818,490 lbs. (4 million kg) of thrust.

#### DÉCOLLAGE

Pour surpasser la force gravitationnelle de la Terre, le SLS de la NASA a produit près de 4 millions de kilos de poussée.

#### DESPEGUE

Para superar la atracción de la gravedad terrestre, el cohete SLS de la NASA produjo casi 4.000.000 kg de empuje.

#### 2 CORE STAGE AND BOOSTERS

Core stage and boosters broke off after their fuel had been used.

#### ÉTAGE PRINCIPAL ET PROPULSEURS D'APPOINT

L'étage principal et les propulseurs d'appoint se détachent après l'épuisement de leur carburant.

#### ETAPA CENTRAL Y PROPULSORES

La etapa central y los propulsores se desprendieron una vez agotado su combustible.

#### 3 LOW-EARTH ORBIT (LEO)

The upper part of the rocket, the interim cryogenic propulsion stage and Orion, accelerating at more than 17,398 mph (28,000 km/h), began a circular orbit around Earth. Orion journeys out of LEO without completing a full orbit of Earth!

#### ORBITE TERRESTRE BASSE (OTB)

La partie supérieure de la fusée, l'étage intermédiaire de propulsion cryogénique et Orion, accélérant à plus de 28 000 km/h, entament une orbite circulaire autour de la Terre. Orion quitte l'orbite terrestre basse sans avoir effectué une orbite complète autour de la Terre !

#### ÓRBITA TERRESTRE BAJA (LEO)

La parte superior del cohete, la etapa de propulsión criogénica provisional (ICPS) y la nave Orion, acelerando a más de 28.000 km/h, iniciaron una órbita circular alrededor de la Tierra. ¡La nave Orion abandonó la LEO sin siquiera completar una órbita alrededor de la Tierra!

6



#### 4 TRANS-LUNAR INJECTION (TLI)

The interim cryogenic propulsion stage accelerated the vehicle to overcome the pull of Earth's gravity, propel Orion out of low-Earth orbit and get it close enough to be captured by the Moon's gravity.

#### INJECTION TRANSLUNAIRE (ITL)

L'étage intermédiaire de propulsion cryogénique fait accélérer le véhicule pour surpasser la force gravitationnelle de la Terre, propulser Orion hors de l'orbite terrestre basse et le rapprocher suffisamment pour qu'il soit attiré par la force gravitationnelle de la Lune.

#### INYECCIÓN TRANSLUNAR (TLI)

La ICPS aceleró el vehículo para superar la atracción de la gravedad terrestre, propulsar la Orion fuera de la órbita terrestre baja y acercarla lo suficiente a la Luna para que fuera capturada por su gravedad.

#### 5 TO THE MOON

The interim cryogenic propulsion stage separated from Orion. Orion headed to the Moon for its three-week mission, while the CubeSats deployed from the OSA/ICPS continued on a similar path to study the Moon and deep space.

#### VERS LA LUNE

L'étage intermédiaire de propulsion cryogénique se sépare d'Orion. Orion se dirige vers la Lune pour une mission de trois semaines, tandis que les CubeSats déployés par l'OSA/ICPS poursuivent leur route vers l'étude de la Lune et de l'espace lointain.

#### A LA LUNA

La ICPS se separó de la Orion. La Orion se puso rumbo a la Luna para su misión de tres semanas, mientras que los satélites CubeSat desplegados desde el adaptador de la Orion (OSA)/ICPS continuaron un camino similar para estudiar la Luna y el espacio profundo.

#### 6 SYSTEMS AND ENVIRONMENT TESTING

Orion fired the maneuvering engines on its service module to bring the spaceship around the far side of the Moon. NASA tested critical systems in the environment of deep space.

#### TESTS DES SYSTÈMES ET DE L'ENVIRONNEMENT

Orion allume les moteurs de manœuvre de son module de service pour conduire le vaisseau spatial autour de la face cachée de la Lune. La NASA teste des systèmes critiques dans l'environnement de l'espace lointain.

#### PRUEBAS DE LOS SISTEMAS Y EL ENTORNO

La Orion encendió los motores de maniobra de su módulo de servicio para sobrevolar la cara oculta de la Luna. La NASA probó los sistemas críticos en el entorno del espacio profundo.

7

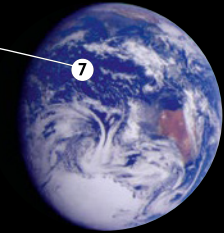

#### 7 RETURN TO EARTH

Upon Orion's re-entry to Earth, the heat shield endures temperatures up to 5,000° F (2,760° C, or half as hot as the surface of the Sun!) and is recovered from the Pacific Ocean off the coast of California.

#### RETOUR SUR TERRE

Lors de la rentrée d'Orion sur Terre, le bouclier thermique supporte des températures allant jusqu'à 2 760 °C (soit moitié moins que la surface du soleil !) Orion est ensuite récupéré dans l'océan Pacifique, au large des côtes californiennes.

#### REGRESO A LA TIERRA

Luego del reingreso de la Orion a la atmósfera terrestre, su escudo térmico tuvo que soportar temperaturas de hasta 2760 °C (¡la mitad de la temperatura de la superficie del Sol!) y fue recuperada en el océano Pacífico frente a las costas de California.

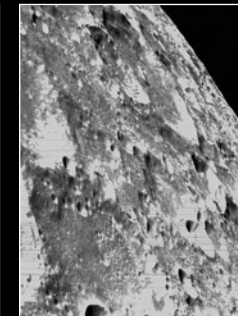
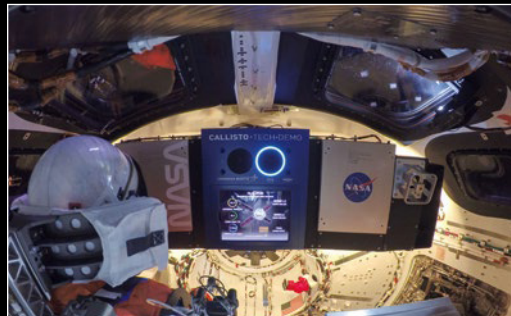



NASA

ESA



# ARTEMIS I-V

▶ Honoring the Apollo missions (1961-1972), the name of NASA's Artemis missions also draws inspiration from Greek mythology, which revered Artemis as the goddess of the Moon and twin sister to Apollo. With its first flight test completed successfully, four additional Artemis missions have been confirmed for the coming years. Each mission aims to test and optimize SLS and Orion performance, lunar re-entry velocities, deep space operations and deployment of payloads. Ultimately, the goal is to expand the potential for crewed missions to Mars – and beyond.

▶ Suivant la tradition des missions Apollo (1961-1972), le nom des missions Artemis de la NASA s'inspire également de la mythologie grecque, qui célèbre Artémis comme déesse de la Lune et sœur jumelle d'Apollon. Puisque le premier essai en vol a été effectué avec succès, quatre autres missions Artemis ont été confirmées pour les années à venir. Chaque mission vise à tester et à optimiser les performances du SLS et d'Orion, les vitesses de rentrée lunaire, les opérations dans l'espace lointain et le déploiement de charges utiles. À terme, l'objectif est d'élargir le potentiel des missions avec équipage vers Mars et plus loin encore.

▶ En honor a las misiones Apolo (1961-1972), el nombre de las misiones Artemis de la NASA también está inspirado en la mitología griega, que veneraba a Artemisa como diosa de la Luna y hermana gemela de Apolo. Con el éxito de su primera prueba de vuelo, se han confirmado otras cuatro misiones Artemis para los próximos años. Cada misión tiene por objetivo probar y optimizar el desempeño del SLS y la Orion, las velocidades de reingreso lunar, las operaciones en el espacio profundo y el despliegue de cargas útiles. En última instancia, la meta es ampliar su potencial para llevar misiones tripuladas a Marte y más allá.

## I

▶  
FIRST MISSION  
(UNCREWED FLIGHT TEST)

▶  
PREMIÈRE MISSION  
(ESSAI EN VOL SANS ÉQUIPAGE)

▶  
PRIMERA MISIÓN  
(PRUEBA DE VUELO SIN  
TRIPULACIÓN)

## II

▶  
FIRST CREWED FLIGHT TEST

▶  
PREMIER ESSAI EN VOL AVEC  
ÉQUIPAGE

▶  
PRIMERA PRUEBA DE VUELO  
CON TRIPULACIÓN

## III

▶  
CREWED LANDING AND  
SURFACE EXPEDITION

▶  
ATTERRISSAGE AVEC  
ÉQUIPAGE ET EXPÉDITION  
EN SURFACE

▶  
ATERRIZAJE TRIPULADO  
Y EXPEDICIÓN POR LA  
SUPERFICIE

## IV

▶  
FIRST LUNAR SPACE STATION  
ASSEMBLY MISSION

▶  
PREMIÈRE MISSION  
D'ASSEMBLAGE DE LA  
STATION SPATIALE LUNAIRE

▶  
PRIMERA MISIÓN DE  
ENSAMBLE DE UNA ESTACIÓN  
ESPACIAL LUNAR

## V

▶  
CREWED MOBILE SURFACE  
EXPLORATION AND GATEWAY  
EXPANSION

▶  
EXPLORATION MOBILE DE LA SURFACE  
AVEC ÉQUIPAGE ET EXPANSION DE LA  
STATION GATEWAY

▶  
EXPLORACIÓN MÓVIL TRIPULADA DE  
LA SUPERFICIE Y AMPLIACIÓN DE LA  
ESTACIÓN GATEWAY



# FROM THE LEGO® DESIGNER UN MOT DU CONCEPTEUR LEGO® EN PALABRAS DEL DISEÑADOR DE LEGO®

“Every LEGO® set based on reality has a history. With the NASA SLS, we can't even begin to imagine its role in future space exploration! A little bit of LEGO rocket science was required when designing this model, as we wanted to have different functional stages of the rocket. The launch tower required a special way of building, using sticks and LEGO Technic™ connectors to make and stack the latticework sections. Just like in real life, a vehicle safety system secures the rocket to the launch tower, and retractable service umbilicals can be disengaged prior to launch by turning a small wheel. Details like staircases and doors help demonstrate the scale of the model. The rocket itself can be removed from the pad. Both boosters can be detached, and after removing a panel, the upper rocket stage is released. When opened, it reveals the Orion spacecraft, featuring deployable solar panels. The rocket can also be separated into smaller pieces just like a real launch rocket, and the Orion spacecraft can be displayed outside the model.”

- Hans Burkhard Schlömer, LEGO® Model Designer

« Chaque ensemble LEGO® basé sur la réalité a une histoire. En ce qui concerne le SLS de la NASA, nous ne pouvons même pas imaginer le rôle qu'il jouera dans l'exploration spatiale à venir ! La conception de ce modèle a nécessité un peu d'ingénierie aérospatiale LEGO, car nous voulions donner plusieurs étages fonctionnels à la fusée. La tour de lancement a nécessité une méthode de construction particulière, avec des bâtons et des clavettes de connexion LEGO Technic™ pour réaliser et empiler les sections en treillis. Comme dans la vraie vie, un système de sécurité fixe la fusée à la tour de lancement, et les ombilicaux de service rétractables peuvent être désengagés avant le lancement en tournant une petite roue. Des détails tels que des escaliers et des portes aident à illustrer l'échelle du modèle. La fusée elle-même peut être détachée de la rampe de lancement. Les deux propulseurs d'appoint peuvent être retirés et l'étage supérieur de la fusée est libéré une fois un panneau ôté. Lorsqu'il est ouvert, l'étage supérieur révèle le vaisseau spatial Orion, doté de panneaux solaires déployables. La fusée peut également être divisée en éléments plus petits, comme une vraie fusée de lancement, et le vaisseau spatial Orion peut être exposé à l'extérieur du modèle. »

- Hans Burkhard Schlömer, concepteur de modèles LEGO®

“Todo set LEGO® basado en la realidad tiene una historia. En el caso del cohete SLS de la NASA, ¡no podemos ni empezar a imaginar su papel en la futura exploración del espacio! El diseño de este modelo nos obligó a aplicar un poco de ciencia de cohetes al estilo de LEGO, ya que queríamos que el cohete tuviera diferentes etapas funcionales. La torre de lanzamiento requirió de una técnica particular basada en el uso de varillas y conectores LEGO Technic™ para dar forma y unir las secciones de celosía. Al igual que en la vida real, hay un sistema de seguridad que sujeta el cohete a la torre de lanzamiento y líneas umbilicales de servicio retráctiles que pueden desconectarse justo antes del lanzamiento girando una pequeña rueda. Detalles como las escaleras y puertas ayudan a poner de manifiesto la escala del modelo. El propio cohete puede retirarse de la plataforma. Ambos propulsores pueden desmontarse, y la etapa superior del cohete se libera al retirar un panel. Cuando está abierta, deja al descubierto la nave espacial Orion, equipada con paneles solares desplegados. Al igual que un vehículo espacial de verdad, el cohete puede separarse en secciones más pequeñas, y la nave espacial Orion también puede exhibirse fuera del modelo”.

- Hans Burkhard Schlömer, modelista de LEGO®

**EACH MAJOR ELEMENT OF THE NASA SLS SERVES A UNIQUE PURPOSE**

**ORION SPACECRAFT**

The Orion spacecraft is made of three primary elements – the launch abort system, the crew module and the service module.

**CORE STAGE**

The SLS core stage is the tallest rocket stage NASA has ever built. At approximately 211.9 ft. (64.6 m) tall and 27.5 ft. (8.4 m) in diameter, its fully fueled weight, excluding engines, is 2.4 million pounds (1,088 metric tons)!

**ENGINE SECTION**

The engine section houses four RS-25 main engines, thrust structure, propellant ducts, avionics systems and thrust vector control systems.

**NOZZLE**

The aft skirt contains the thrust vector control (TVC) system that steers the booster exhaust nozzle based on commands from the booster avionics.

**CHAQUE ÉLÉMENT MAJEUR DU SLS DE LA NASA A UNE FONCTION UNIQUE**

**VAISSEAU SPATIAL ORION**

Le vaisseau spatial Orion est composé de trois éléments principaux : le système d'interruption de lancement, le module d'équipage et le module de service.

**ÉTAGE PRINCIPAL**

L'étage principal du SLS est le plus grand étage de fusée jamais construit par la NASA. Avec une hauteur d'environ 64,6 m et un diamètre de 8,4 m, il pèse 1 088 tonnes métriques avec son plein de carburant, sans compter les moteurs !

**SECTION DES MOTEURS**

La section des moteurs abrite quatre moteurs principaux RS-25, la structure de poussée, les conduits d'ergols, les systèmes avioniques et les systèmes de contrôle du vecteur de poussée.

**TUYÈRE**

La jupe arrière contient le système de contrôle du vecteur de poussée qui dirige la tuyère d'échappement du propulseur en fonction des commandes de l'avionique du propulseur.

**CADA UNO DE LOS ELEMENTOS PRINCIPALES DEL COHETE SLS DE LA NASA TIENE UNA FINALIDAD ÚNICA**

**NAVE ESPACIAL ORION**

La nave espacial Orion consta de tres elementos principales: el sistema de aborto del lanzamiento, el módulo de tripulación y el módulo de servicio.

**ETAPA CENTRAL**

La etapa central del SLS es la etapa de cohete más alta jamás construida por la NASA. Con aproximadamente 64,6 m de altura y 8,4 m de diámetro, su peso con todo el combustible, sin contar los motores, pesa de 1088 t!

**SECCIÓN DE MOTORES**

La sección de motores alberga cuatro motores principales RS-25, la estructura de empuje, los conductos del propelente, los sistemas aviónicos y los sistemas de control del vector de empuje.

**TOBERA**

El faldón posterior contiene el sistema de control del vector de empuje (TVC) que dirige la tobera de escape del propulsor en función de las órdenes de sus sistemas aviónicos.

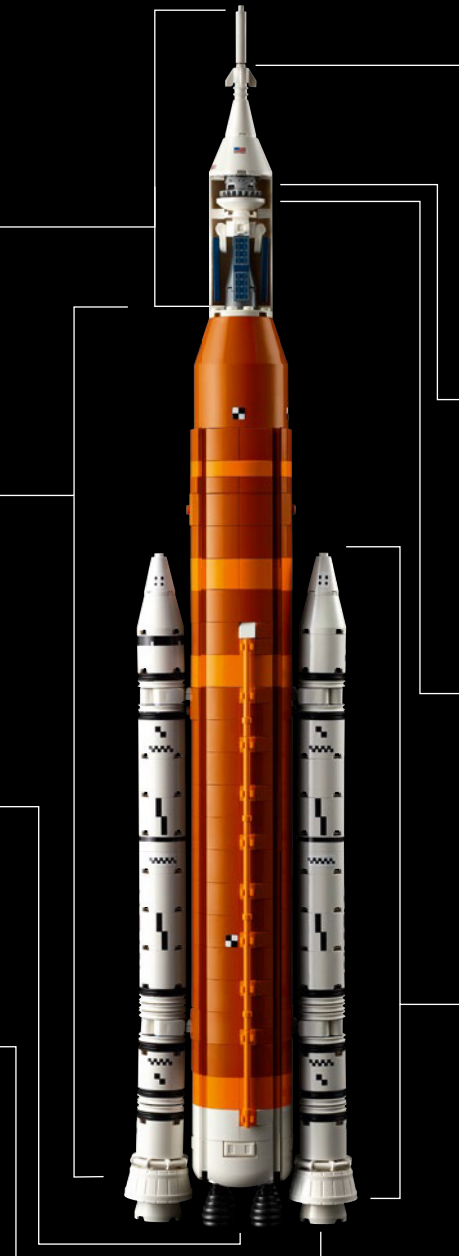

**LAUNCH ABORT SYSTEM (LAS)**

In the case of an emergency during launch, three solid rocket motors work together to propel the Orion and its crew away from the rocket for a safe landing in the ocean.

**CREW MODULE**

The Orion crew module will serve as the habitat for the crew while traveling to the Moon, and provide astronauts with food, water, oxygen and protection from hazards like space radiation.

**EUROPEAN SERVICE MODULE**

Orion's service module is the powerhouse of the spacecraft, supplying it with electricity, propulsion, thermal control and the air and water astronauts need in space. For more information please visit: [esa.int/esm](http://esa.int/esm)

**SOLID ROCKET BOOSTERS**

In real life, the SLS solid rocket boosters are the first element to be installed on the mobile launcher. When loaded with propellant, each booster weighs 1.6 million pounds (726 metric tons)!

**SYSTÈME D'INTERRUPTION DE LANCEMENT**

En cas d'urgence lors du lancement, trois propulseurs à propergol solide travaillent de concert pour projeter Orion et son équipage loin de la fusée, en vue d'un atterrissage en toute sécurité dans l'océan.

**MODULE D'ÉQUIPAGE**

Le module d'équipage d'Orion servira d'habitat à l'équipage lors de son périple vers la Lune et fournira aux astronautes de la nourriture, de l'eau, de l'oxygène ainsi qu'une protection contre les dangers tels que les radiations spatiales.

**MODULE DE SERVICE EUROPÉEN**

Le module de service d'Orion est la centrale électrique du vaisseau spatial. Il lui fournit l'électricité, la propulsion, le contrôle thermique ainsi que l'air et l'eau dont les astronautes ont besoin dans l'espace. Pour en savoir plus, visitez : [esa.int/esm](http://esa.int/esm)

**PROPULSEURS À PROPERGOL SOLIDE**

Dans la réalité, les propulseurs à propergol solide du SLS sont le premier élément à être installé sur le lanceur mobile. Une fois chargé de propergol, chaque propulseur pèse 726 tonnes métriques !

**SISTEMA DE ABORTO DEL LANZAMIENTO (LAS)**

Si llegara a producirse una emergencia durante el lanzamiento, tres cohetes de combustible sólido trabajarían en conjunto para propulsar a la Orion y su tripulación lejos del cohete para aterrizar con seguridad en el océano.

**MÓDULO DE TRIPULACIÓN**

El módulo de tripulación de la Orion servirá de hábitat para la tripulación durante el viaje a la Luna y proporcionará a los astronautas comida, agua, oxígeno y protección frente a peligros como la radiación espacial.

**MÓDULO DE SERVICIO EUROPEO**

El módulo de servicio de la Orion es la fuente de energía que suministra a la nave espacial la electricidad, la propulsión, el control térmico y el aire y el agua que los astronautas necesitan en el espacio. Para más información, visita: [esa.int/esm](http://esa.int/esm)

**PROPULSORES DE COMBUSTIBLE SÓLIDO**

En la vida real, los propulsores de combustible sólido del SLS son el primer elemento que se instala en el lanzador móvil. Cuando están cargados de propelente, ¡cada cohete pesa 726 t!

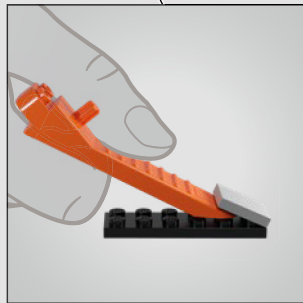
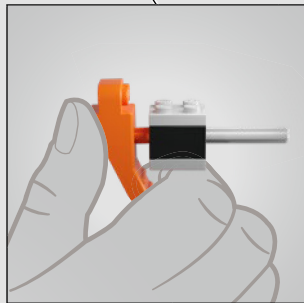
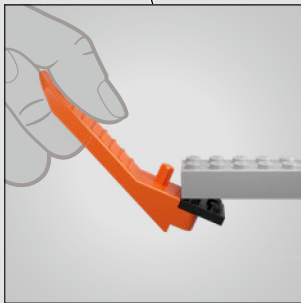
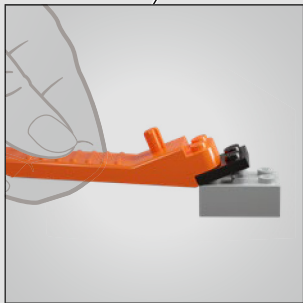
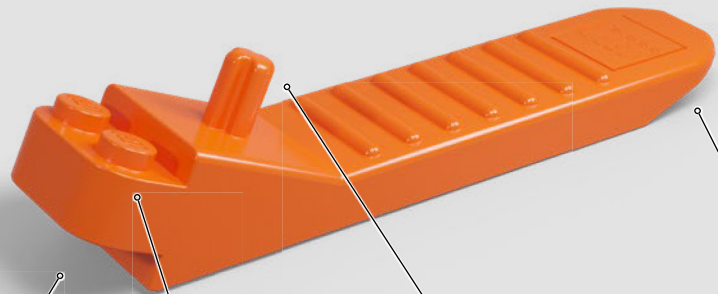

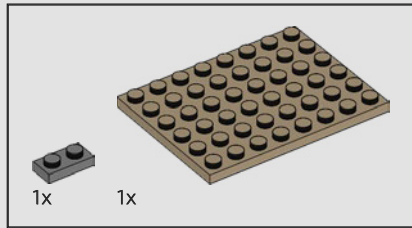

1

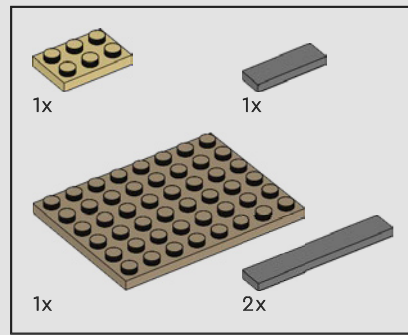
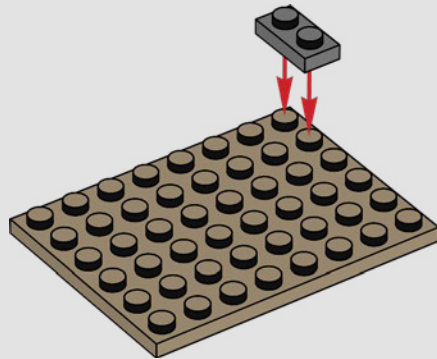

2

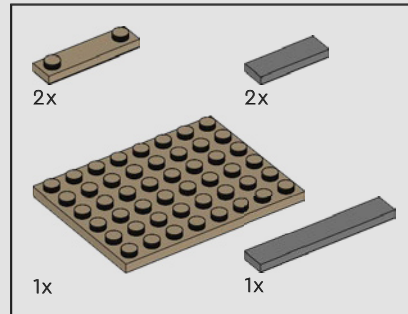
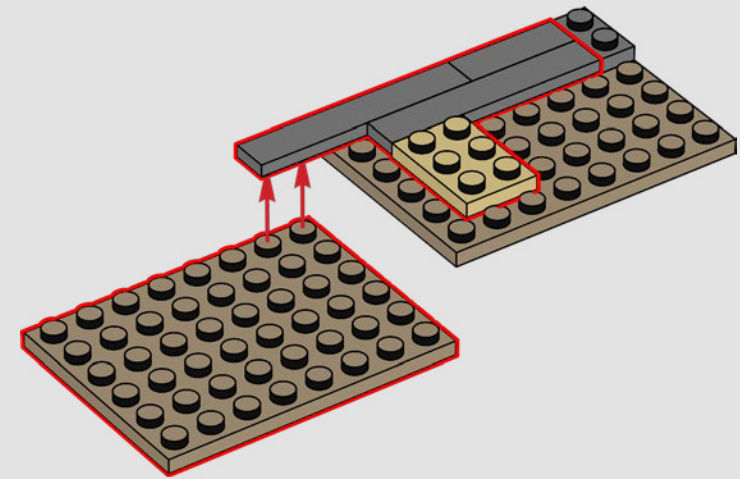

3

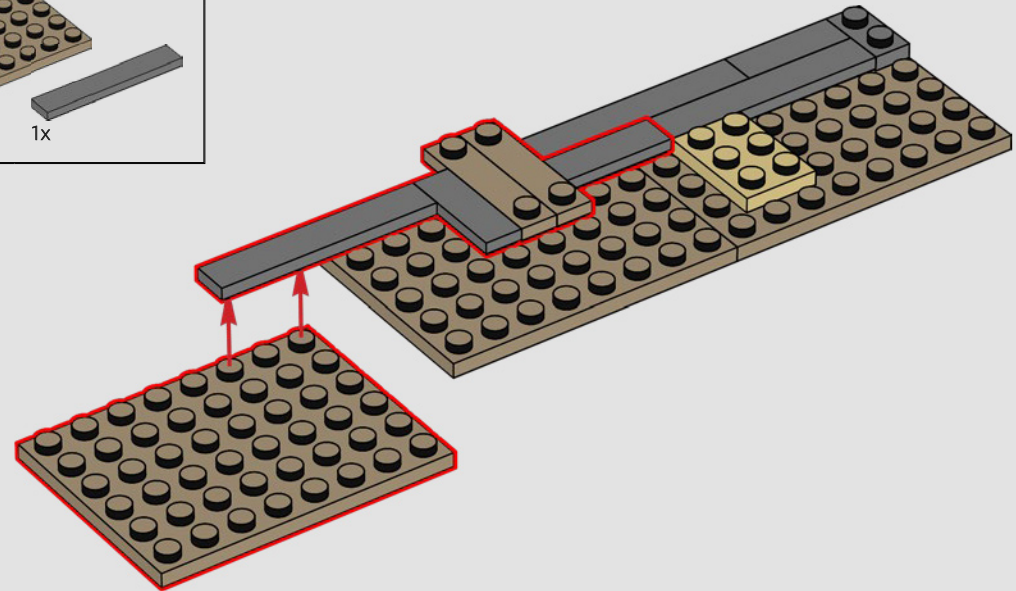

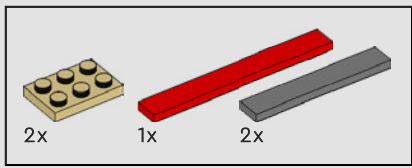

4

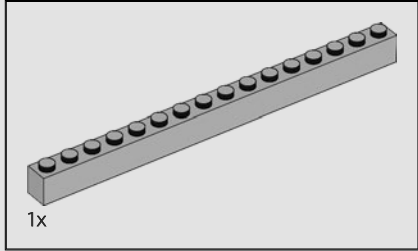
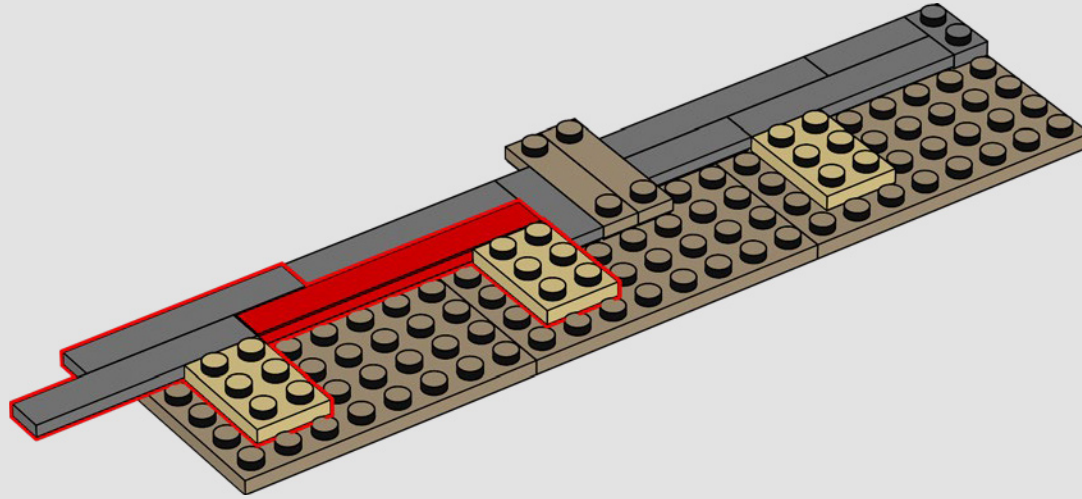

5

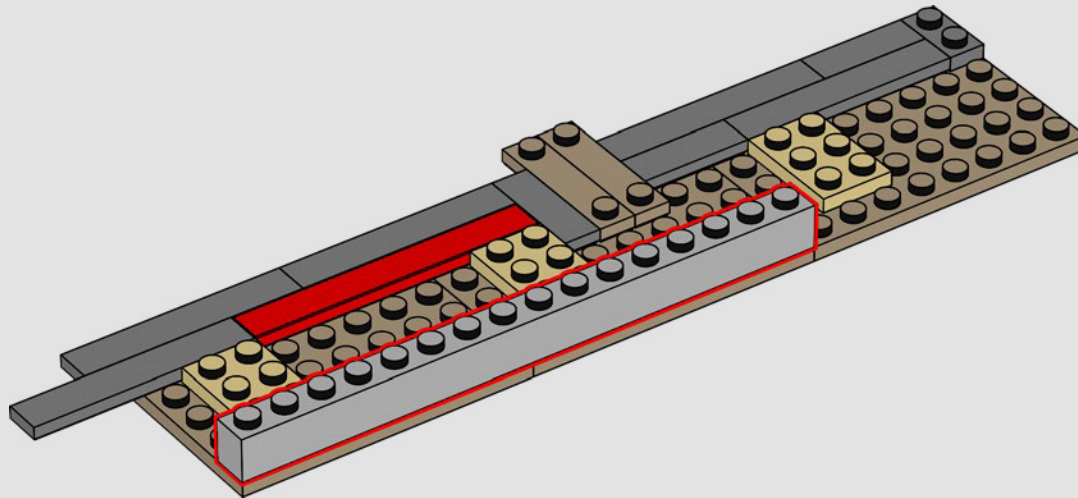

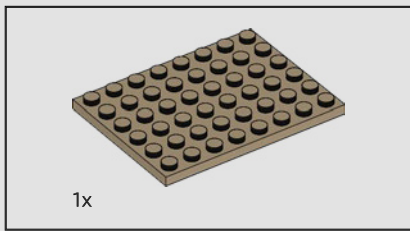

6

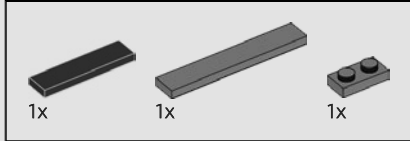
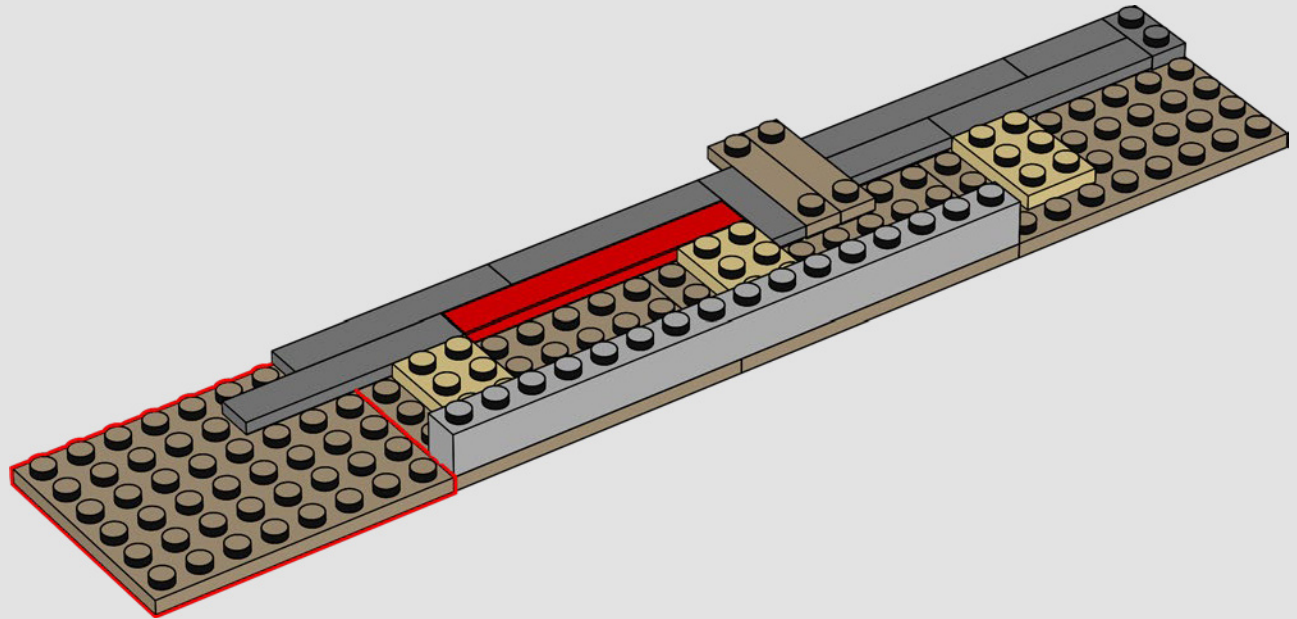

7

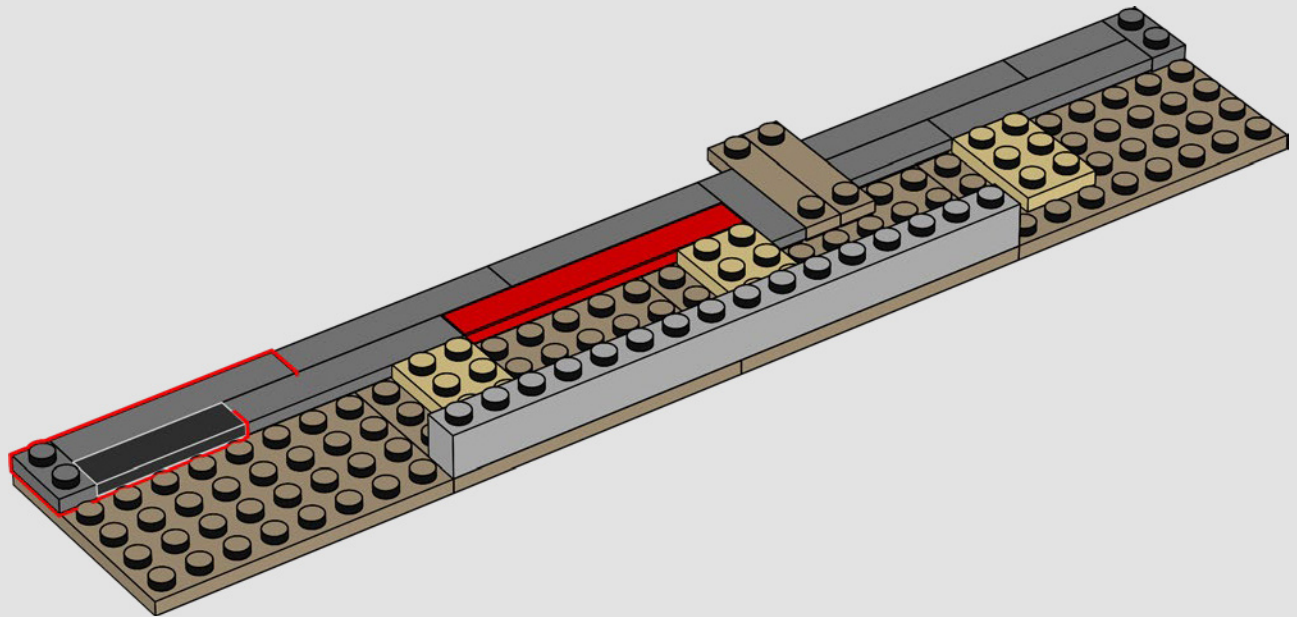

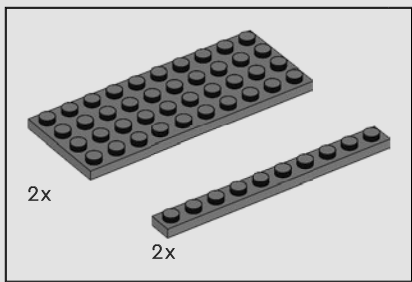

8

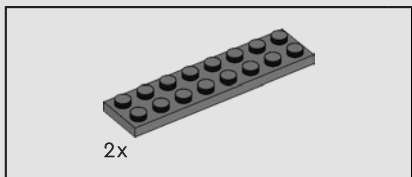
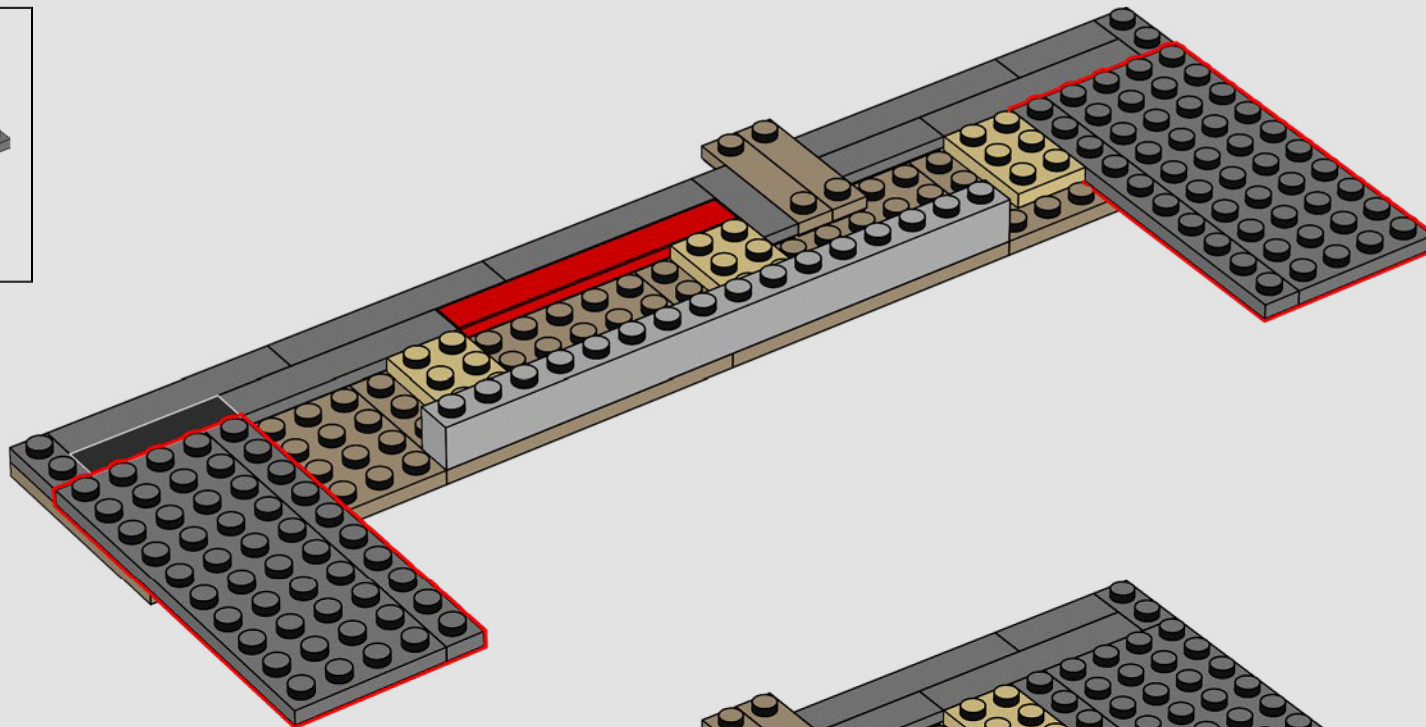

9

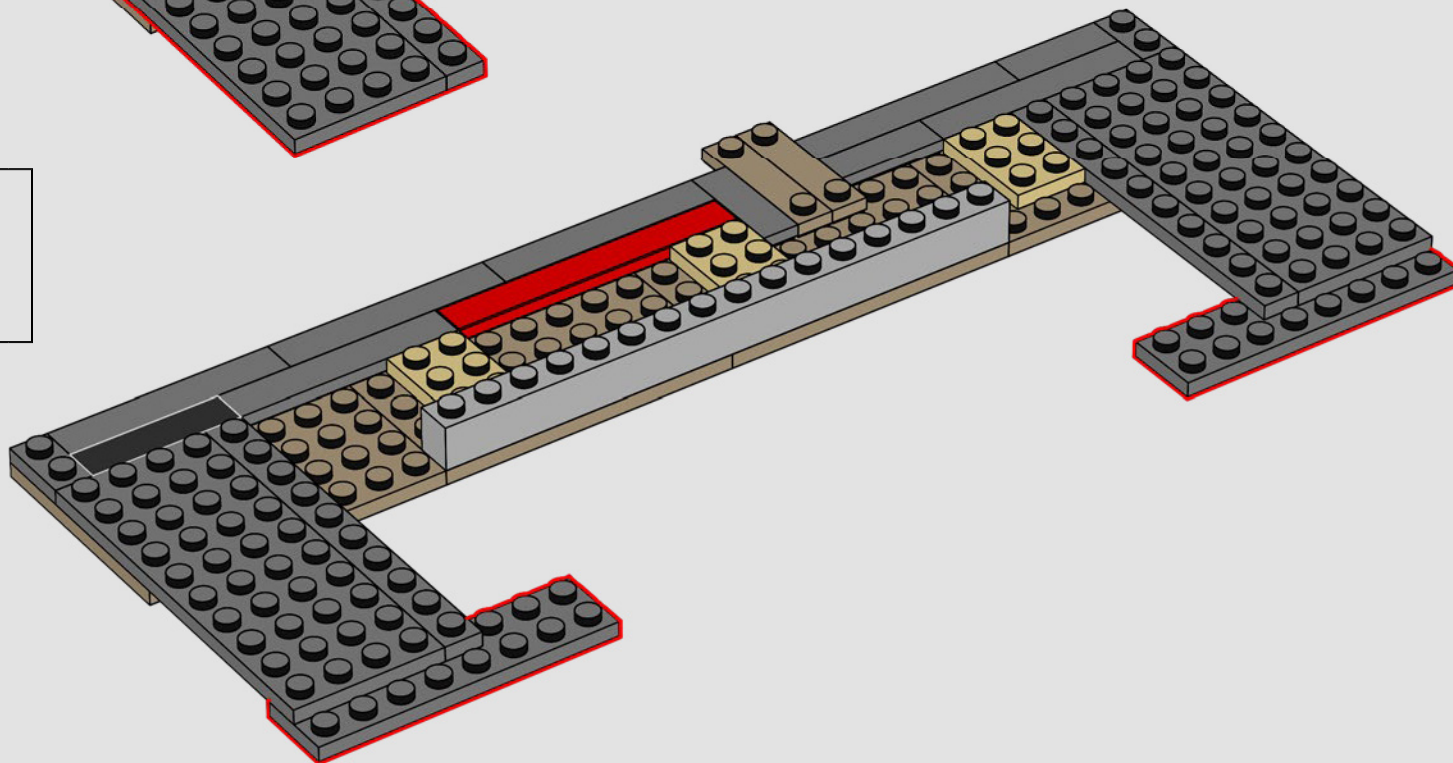



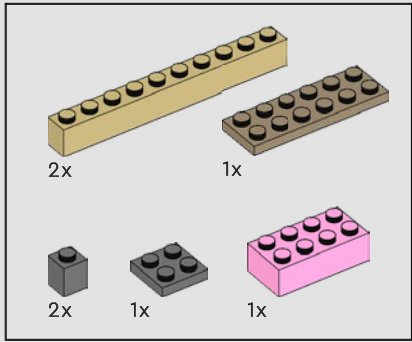

10

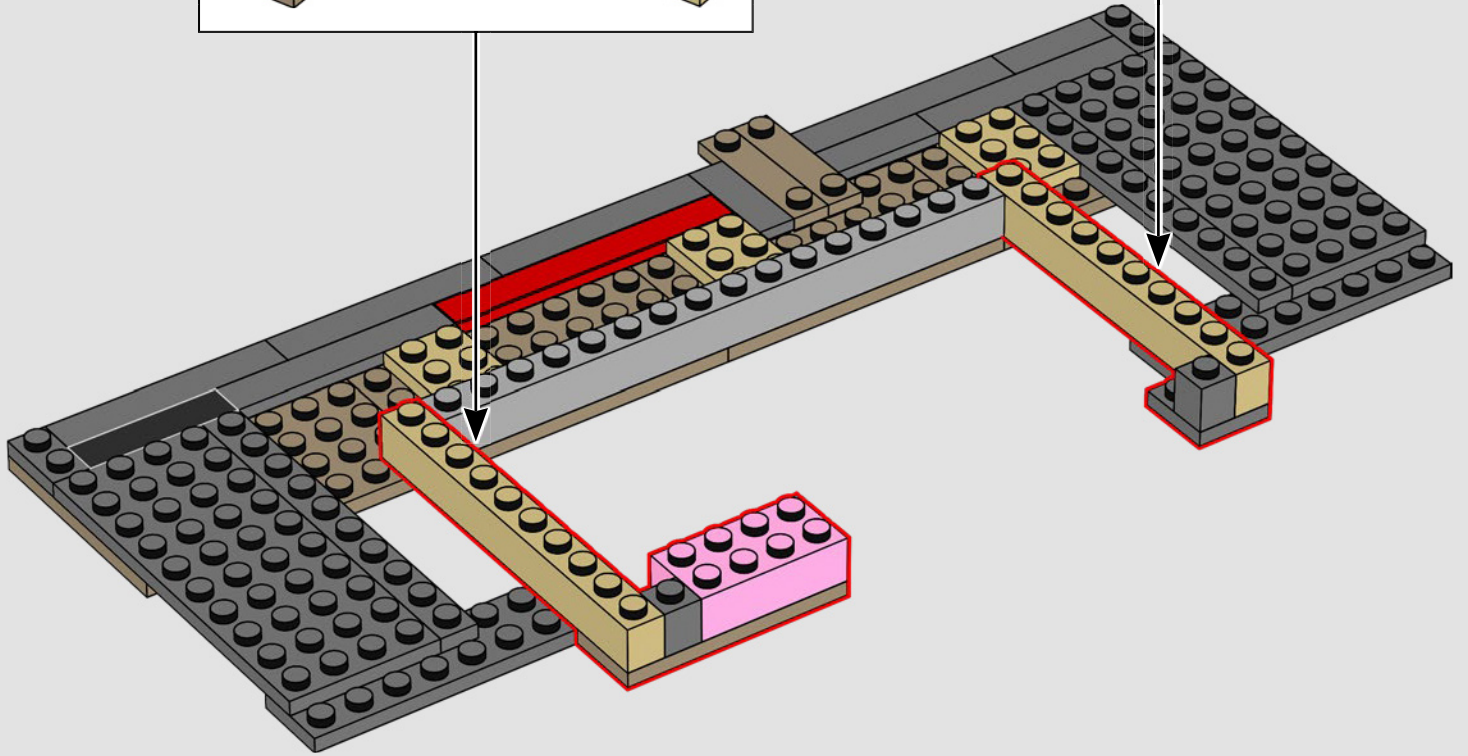
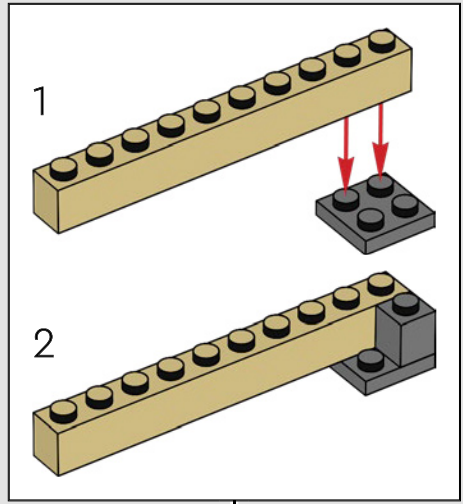
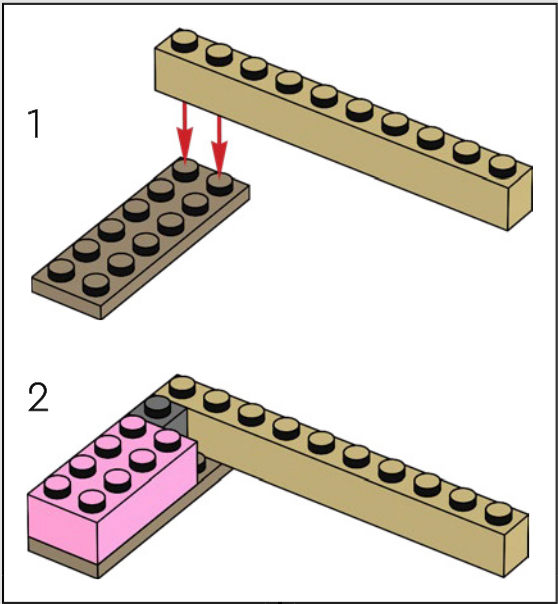

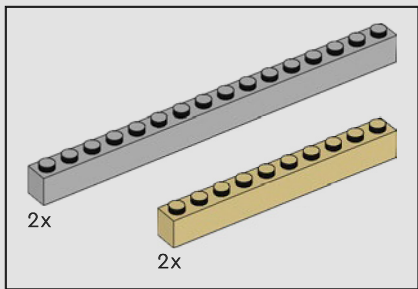

11

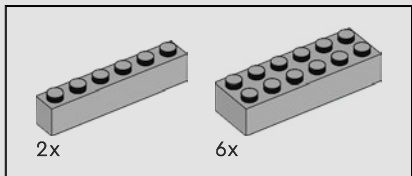
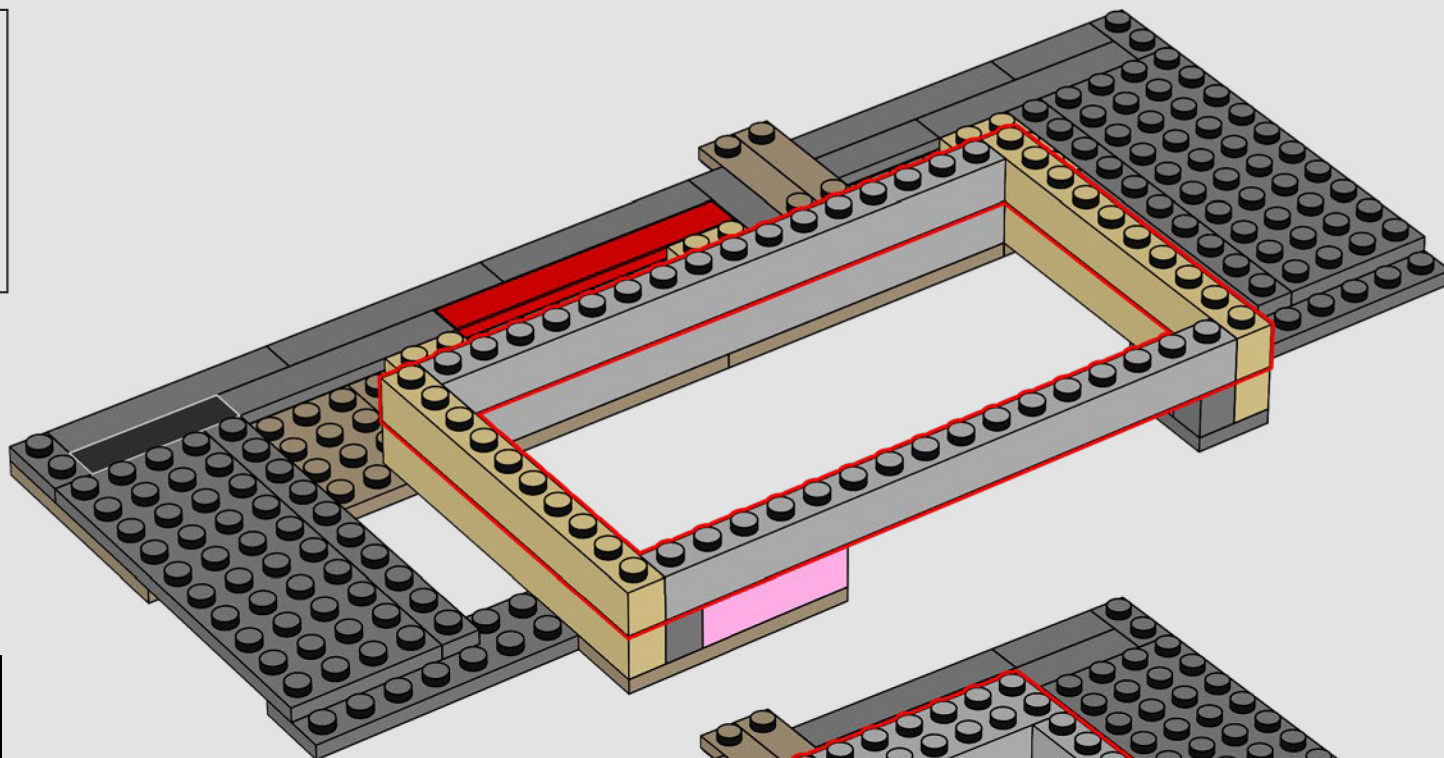

12

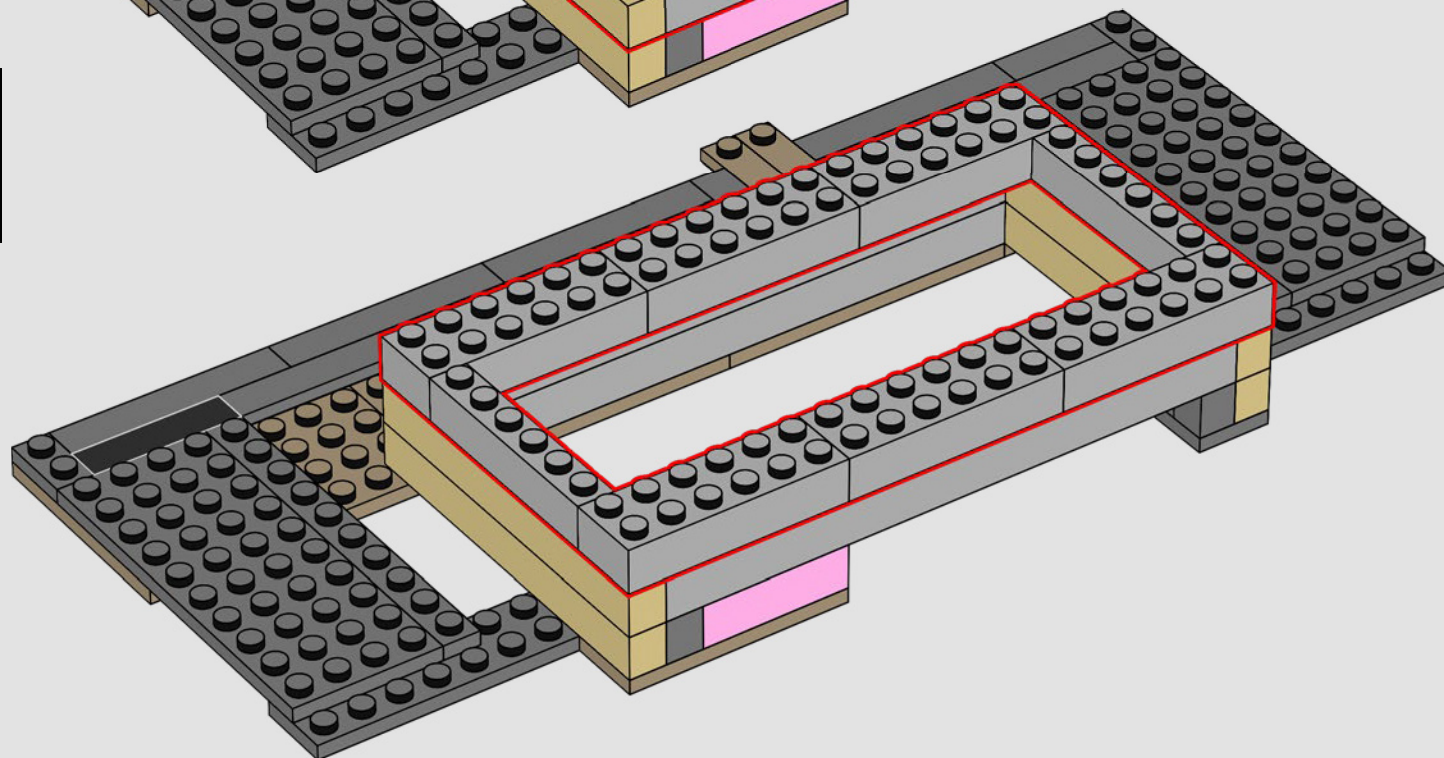

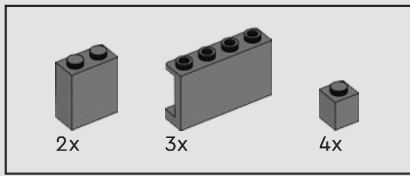

13

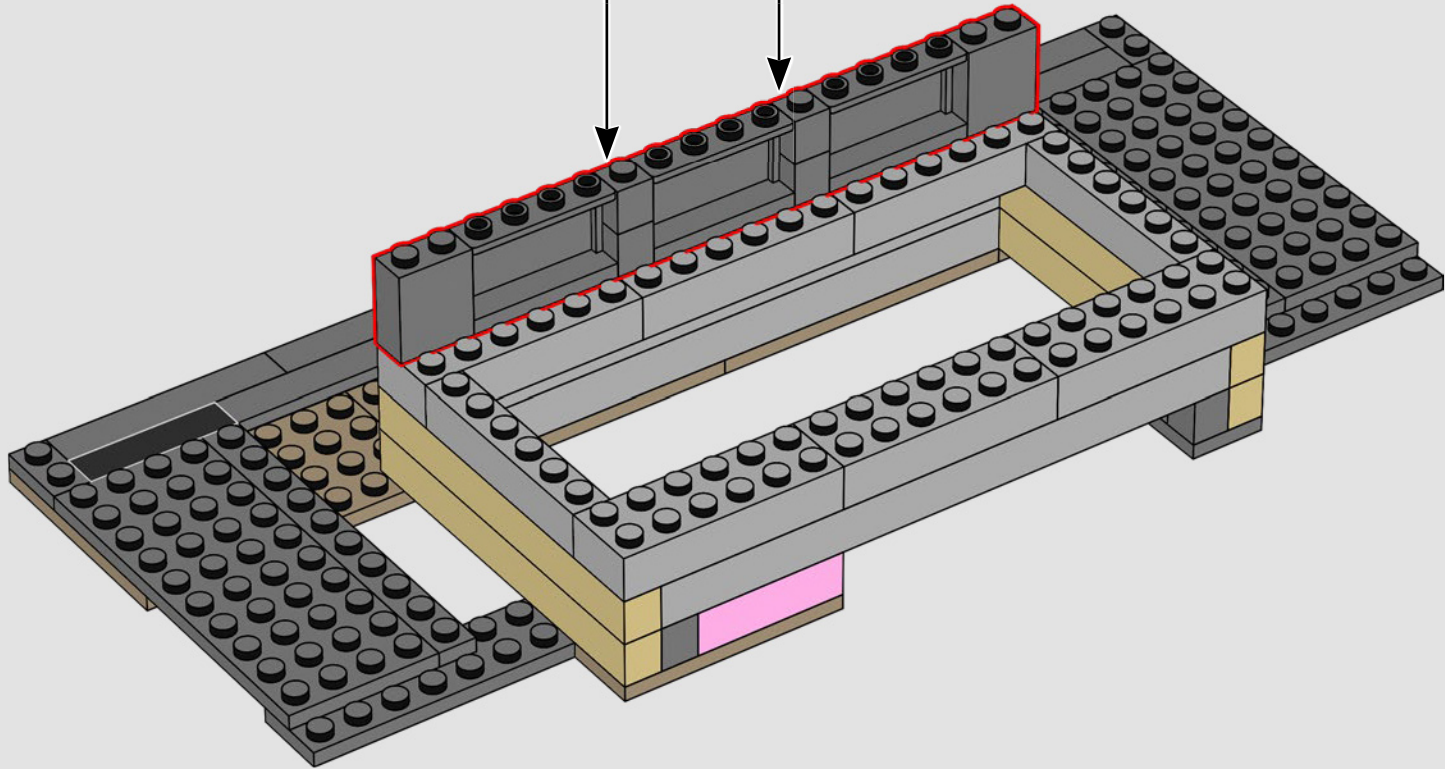
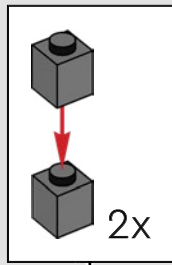

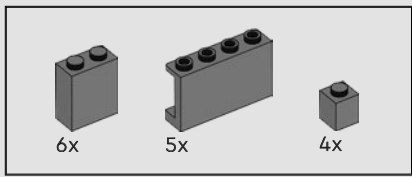

14

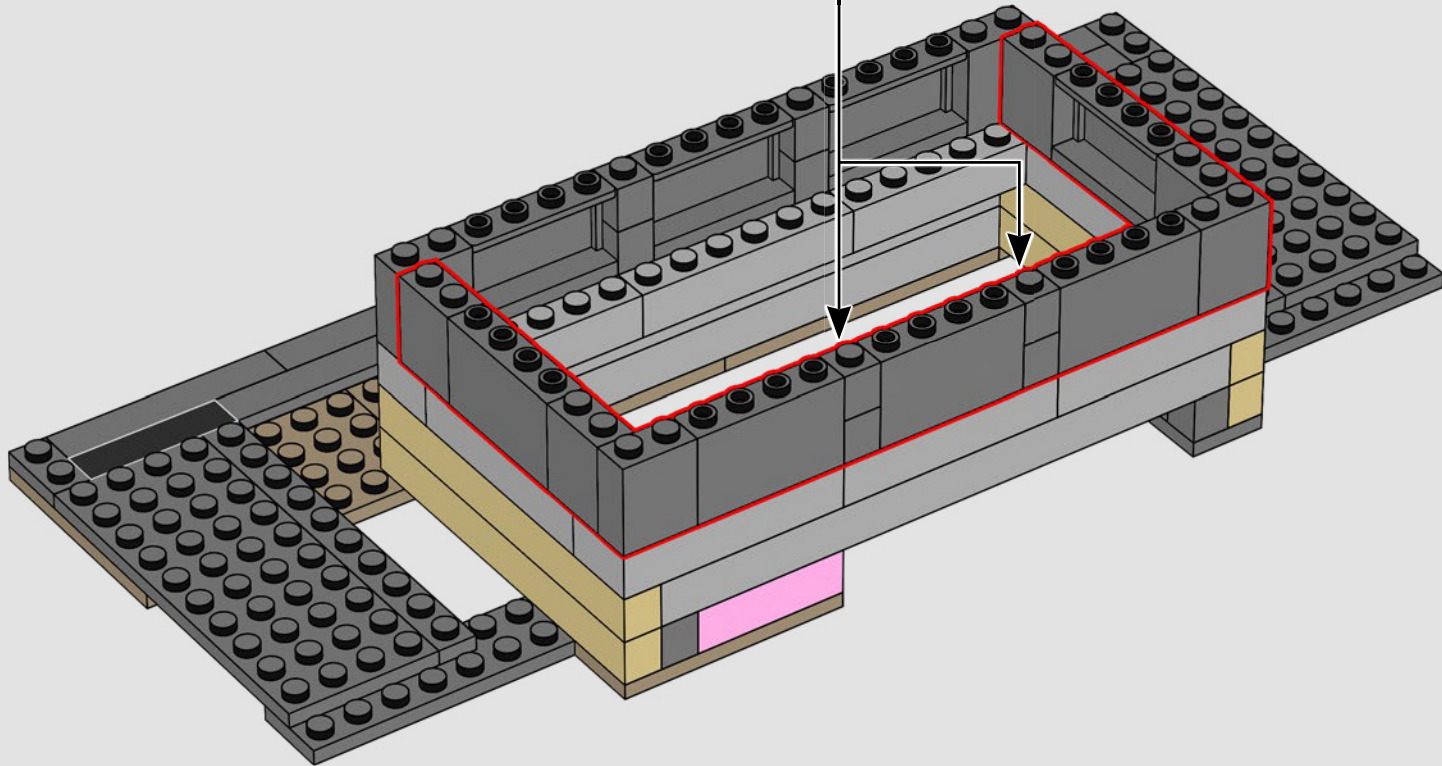
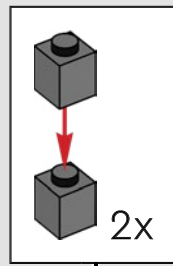

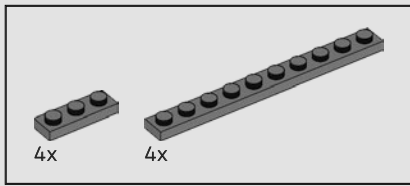

15

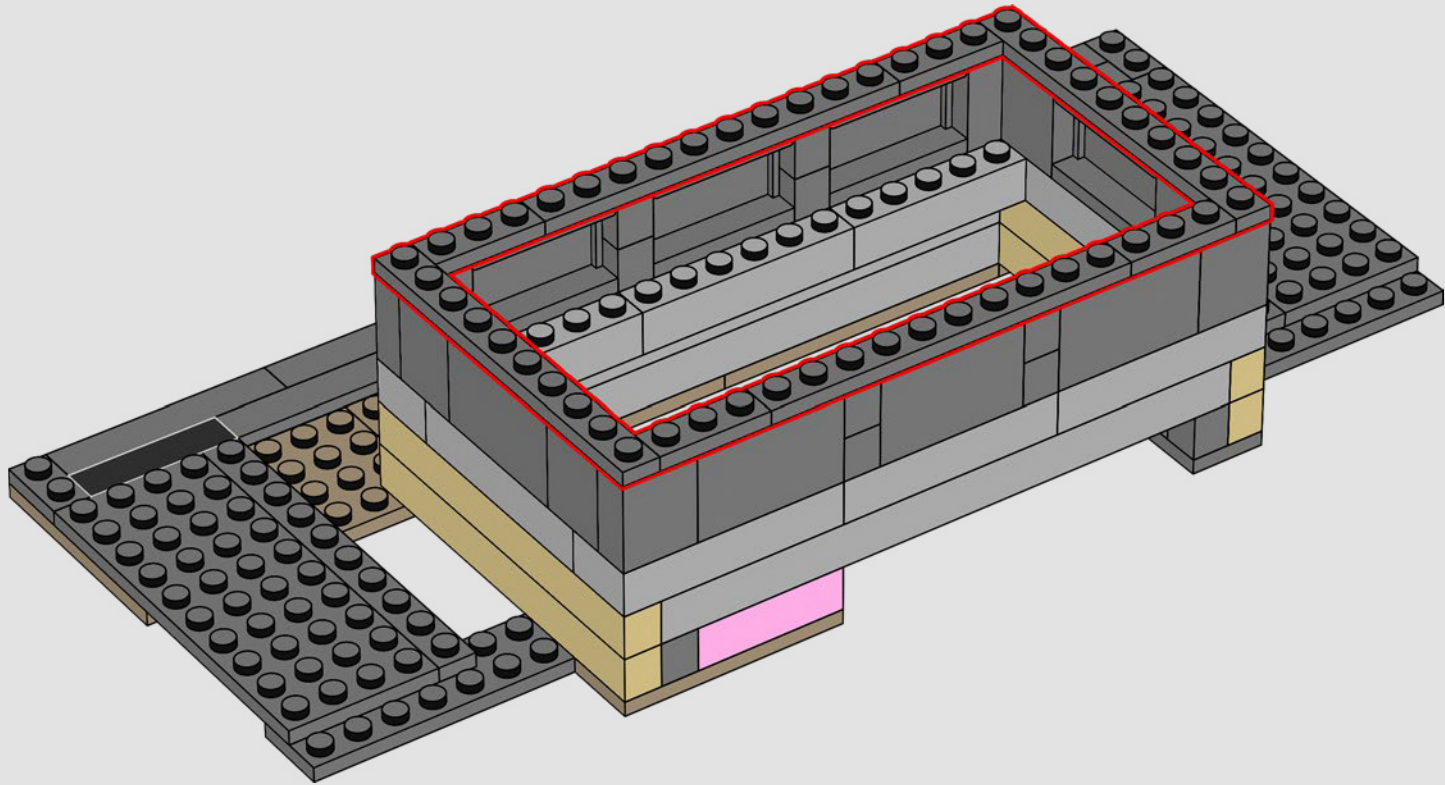

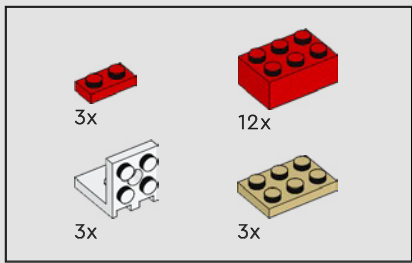

16

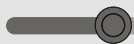
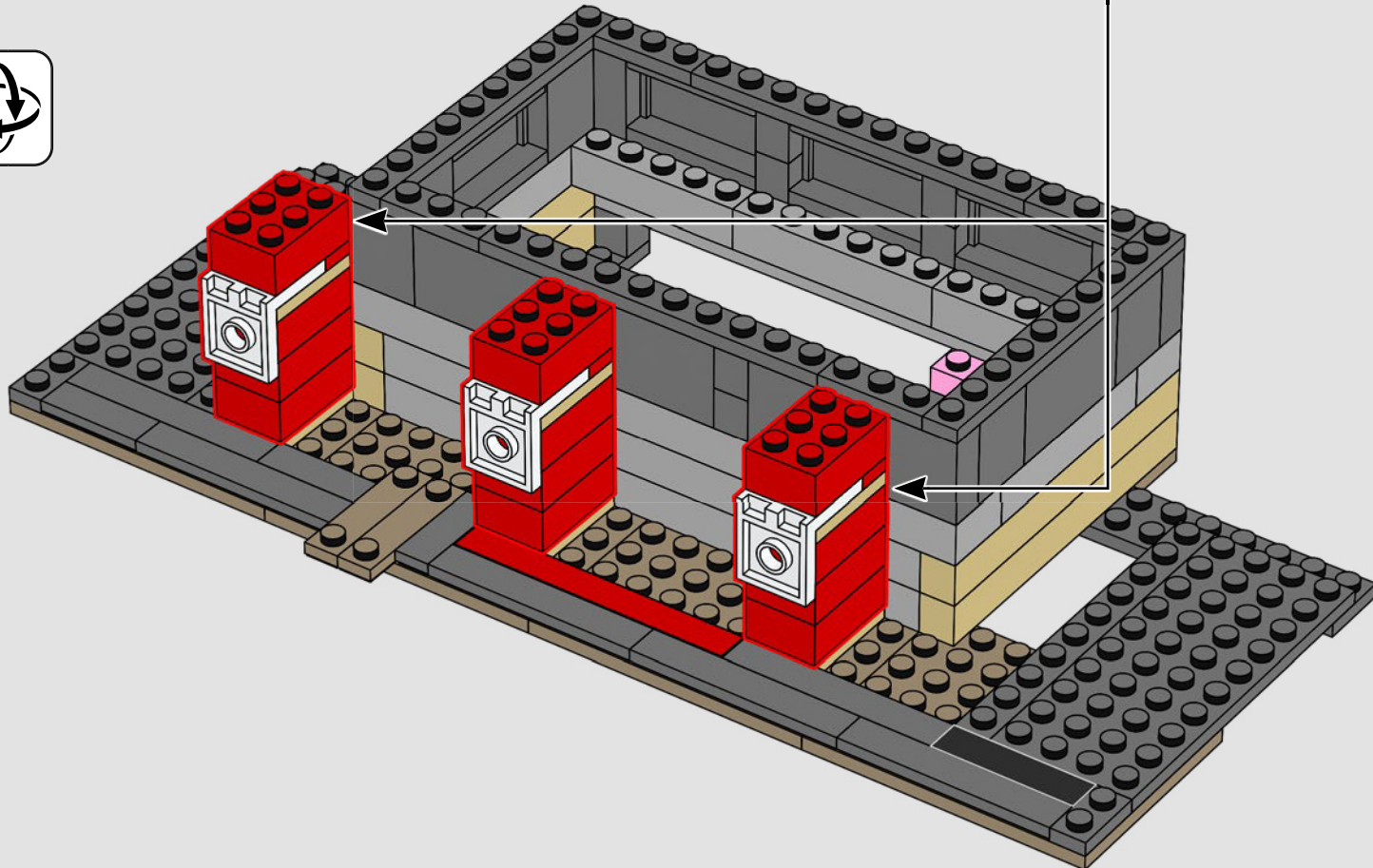
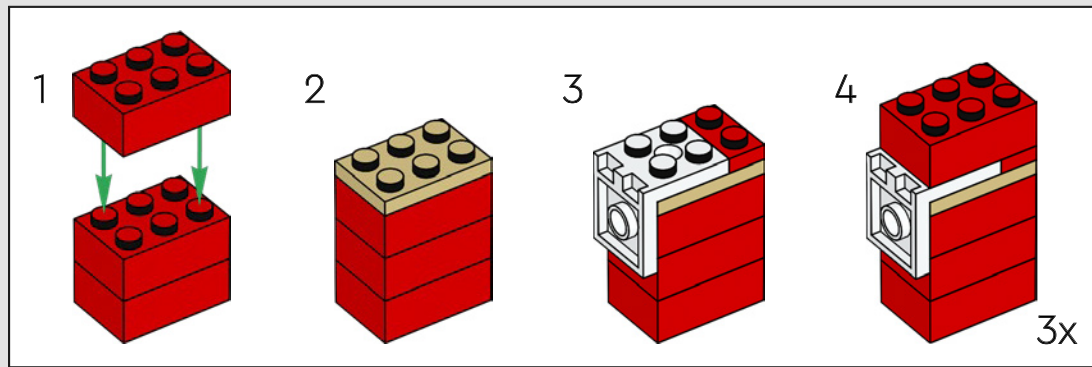

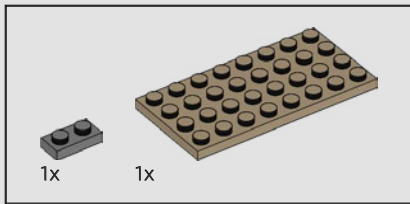
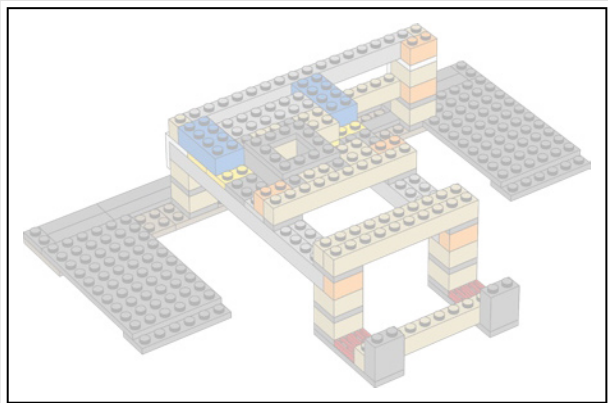

17

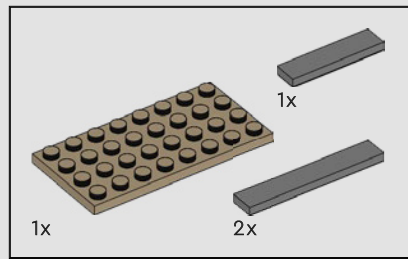
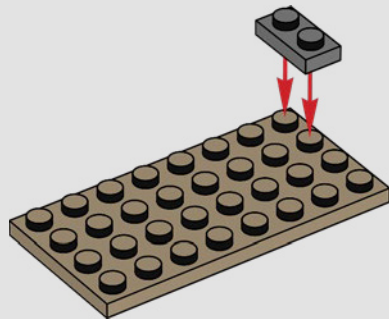

18

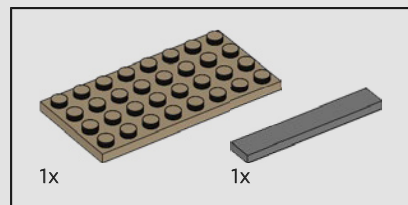
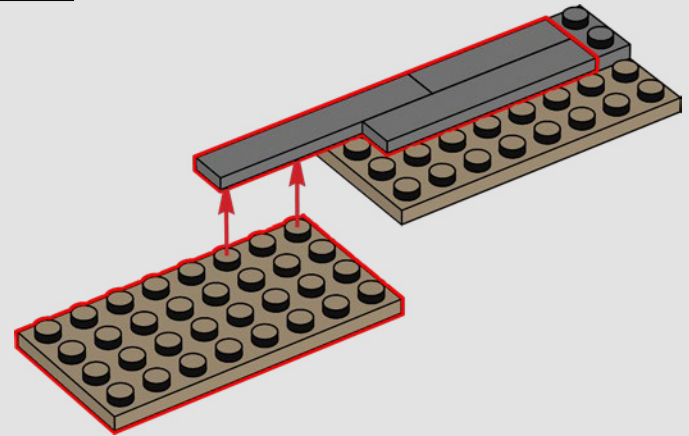

19

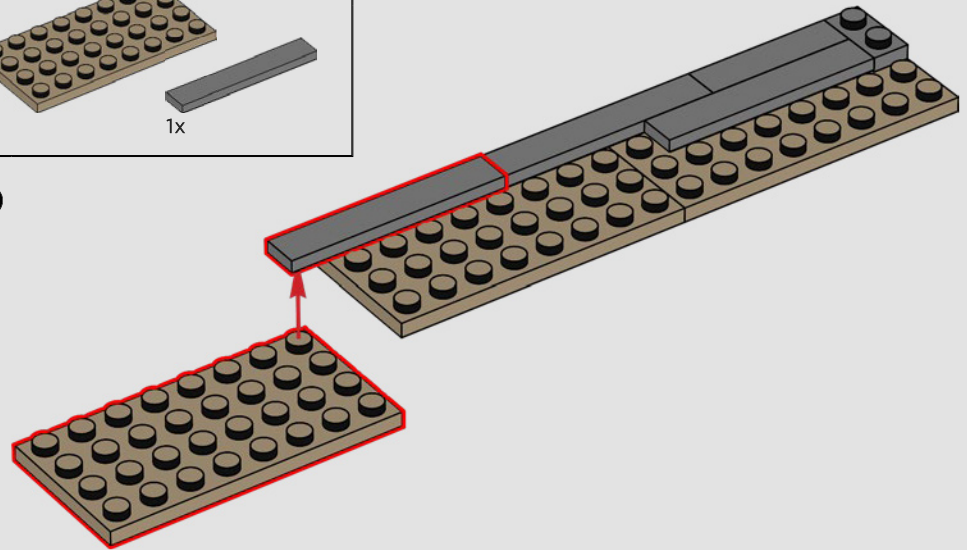

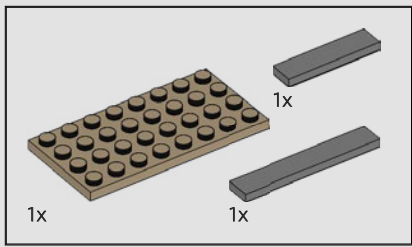

20

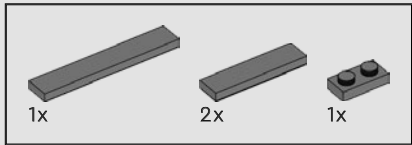
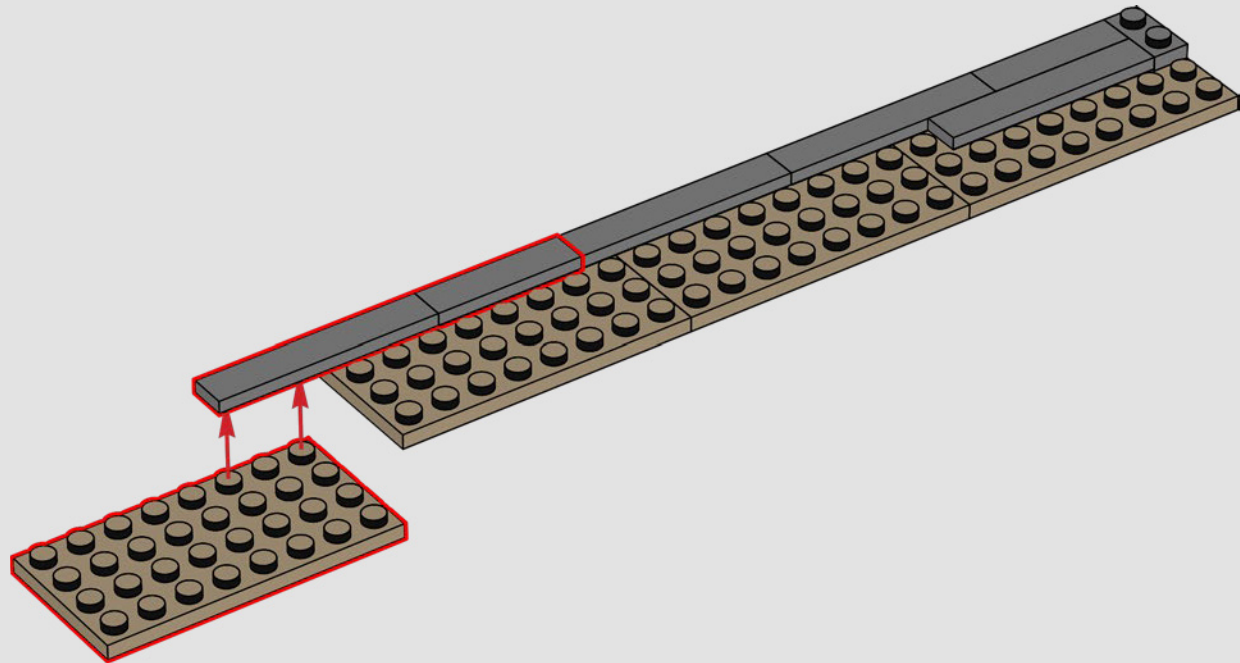

21

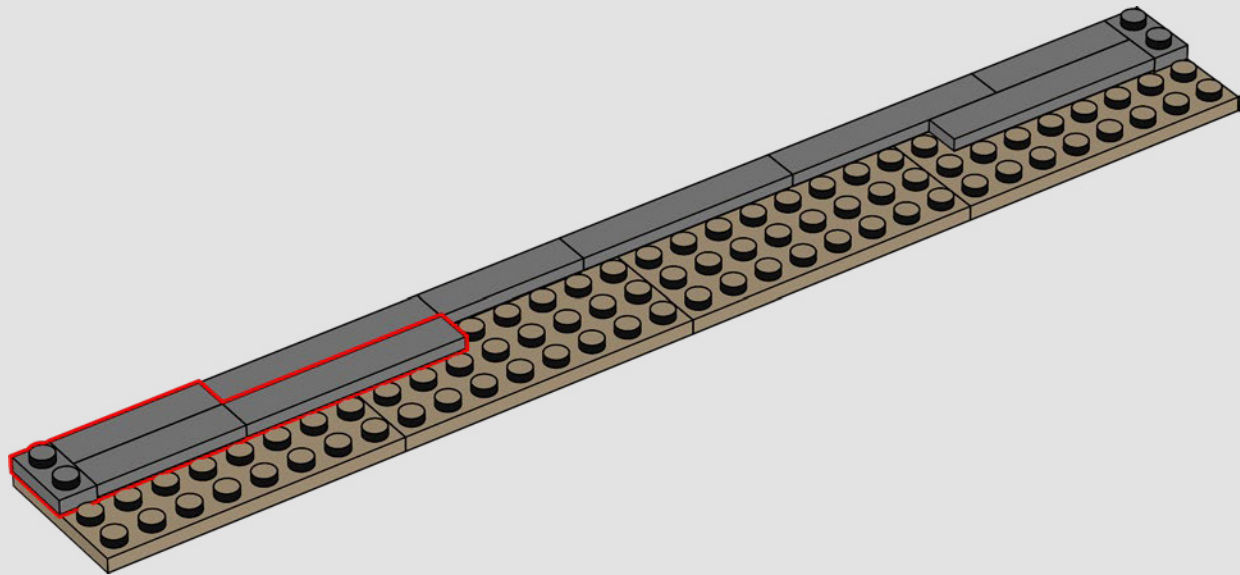



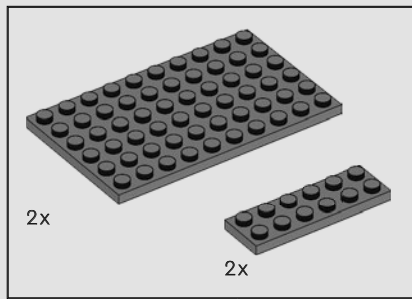

22

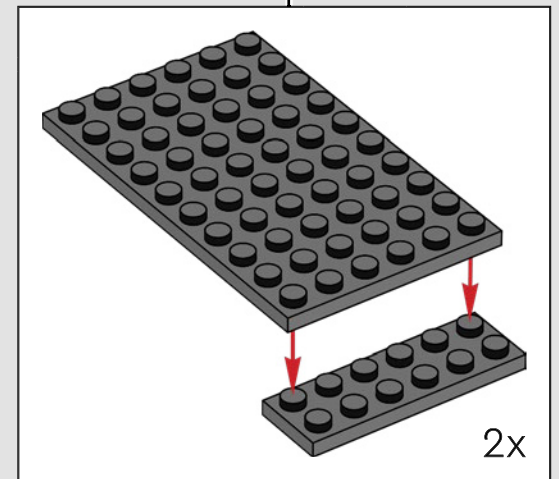
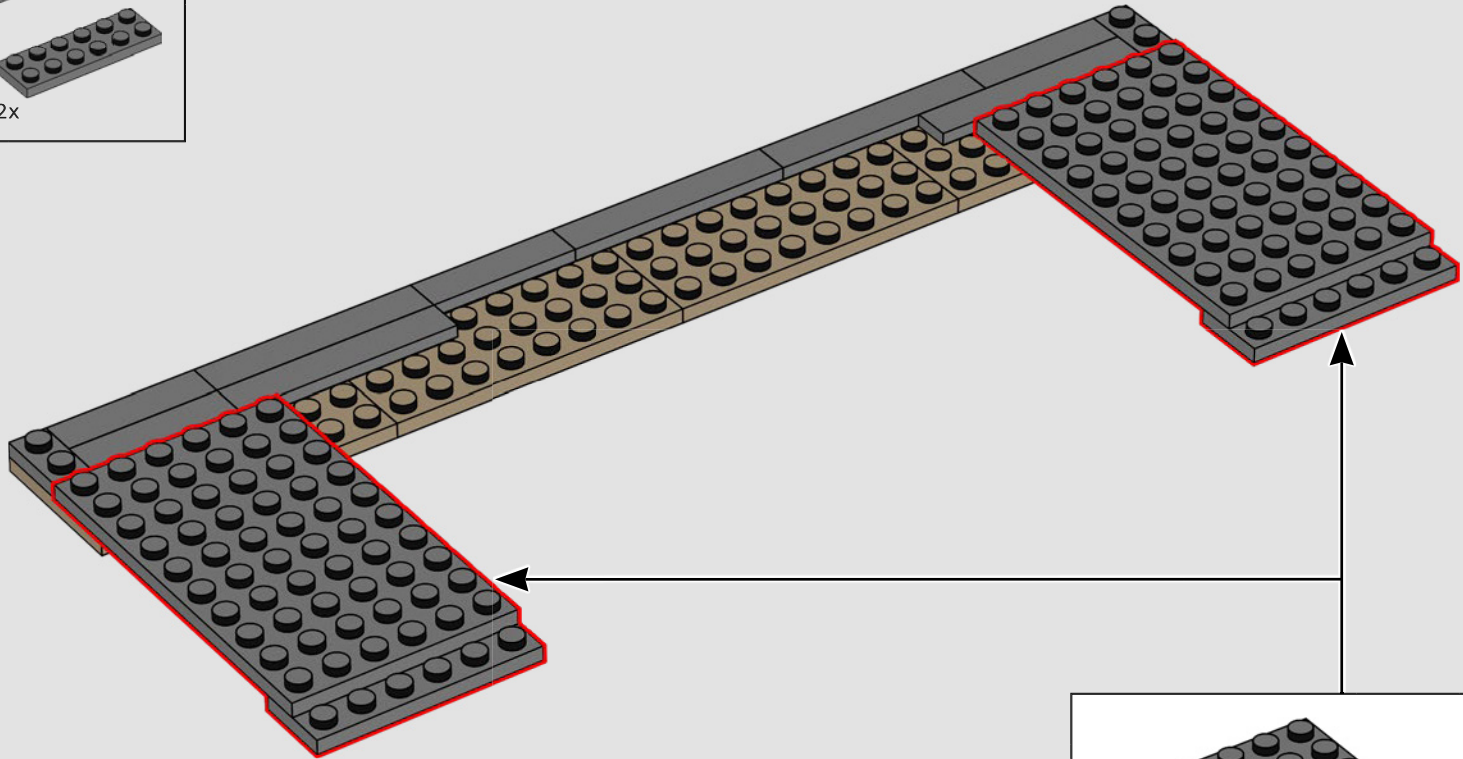

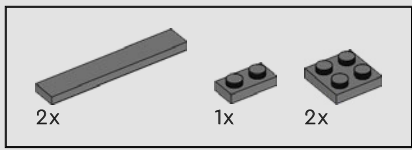

23

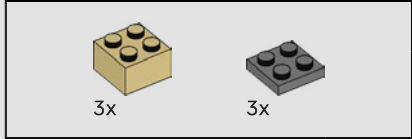
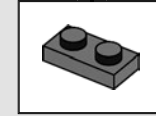
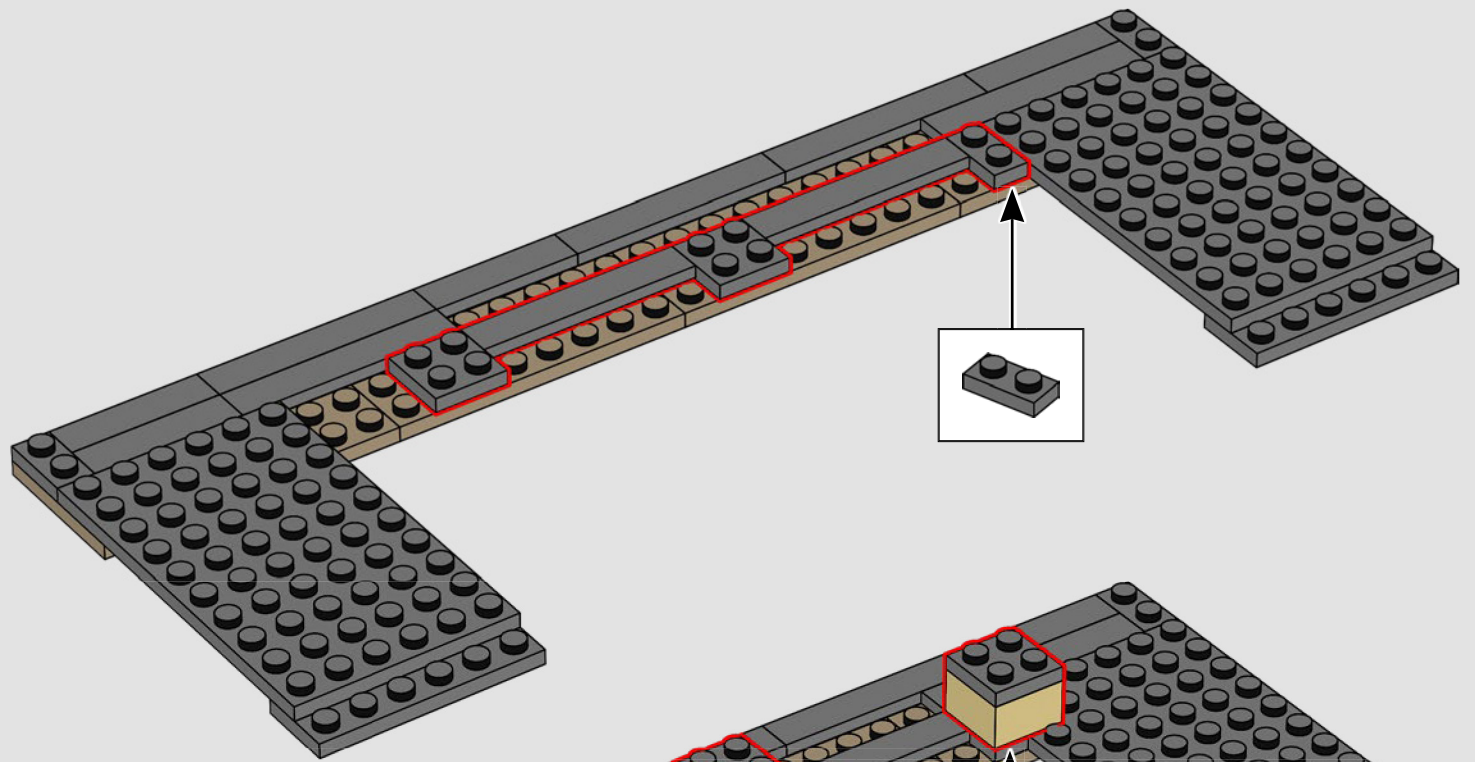

24

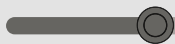
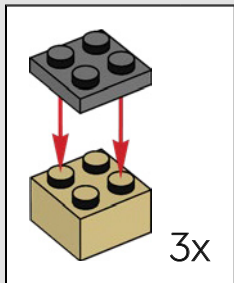
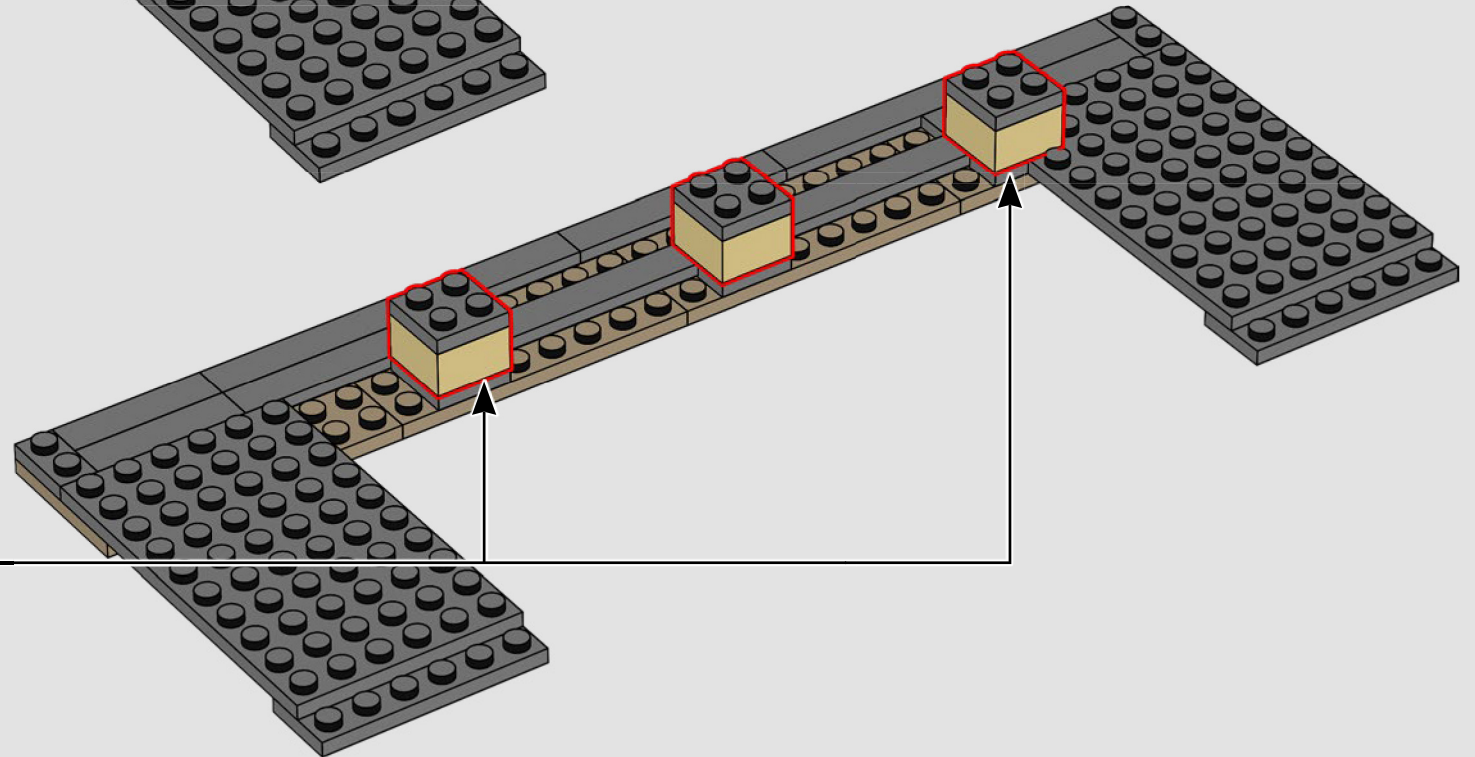

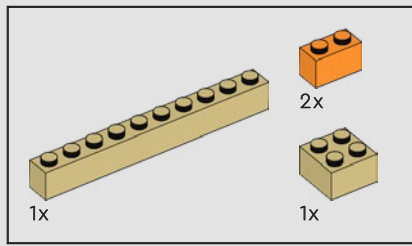

25

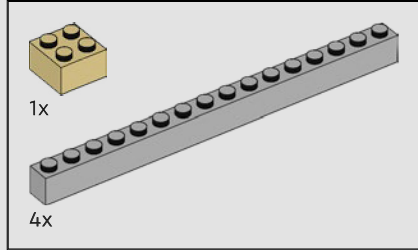
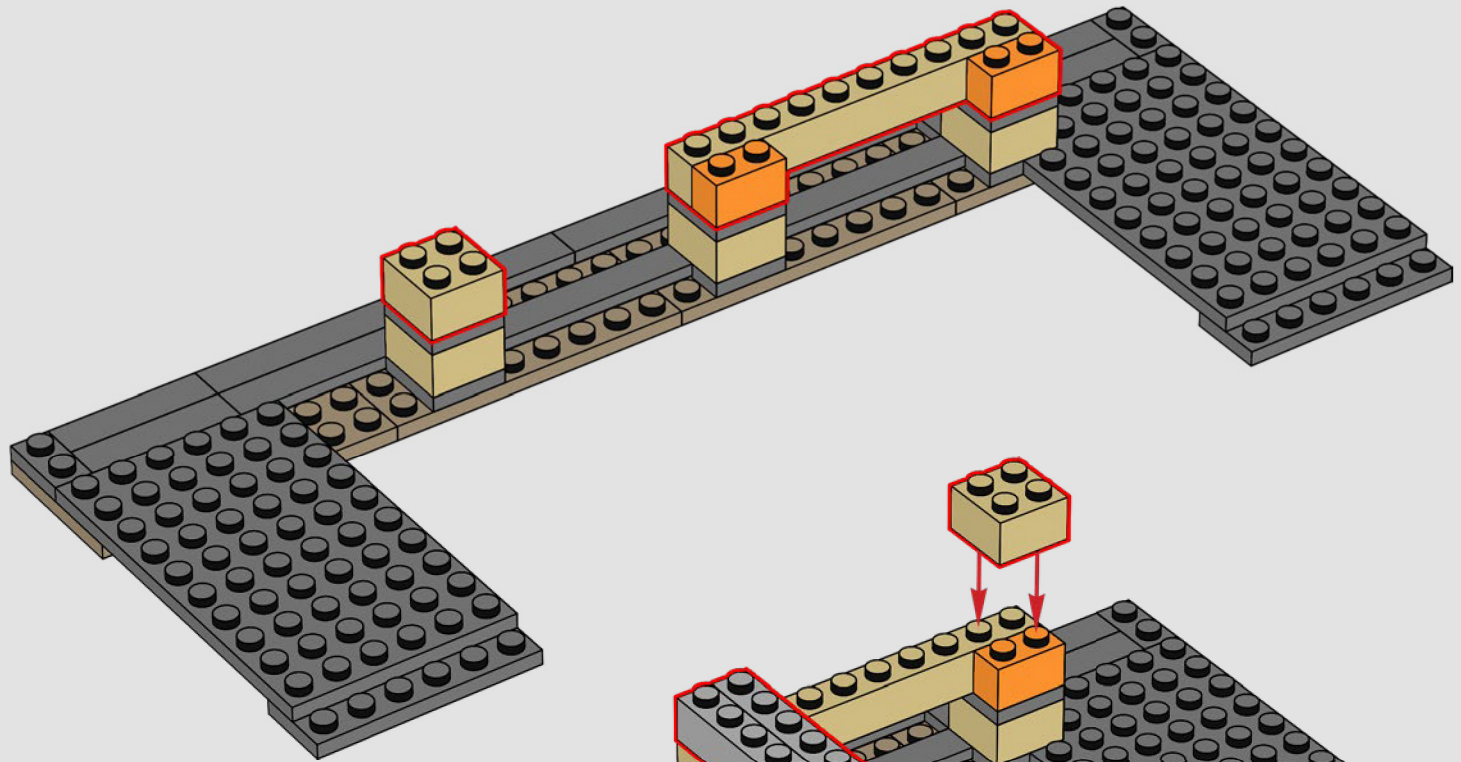

26

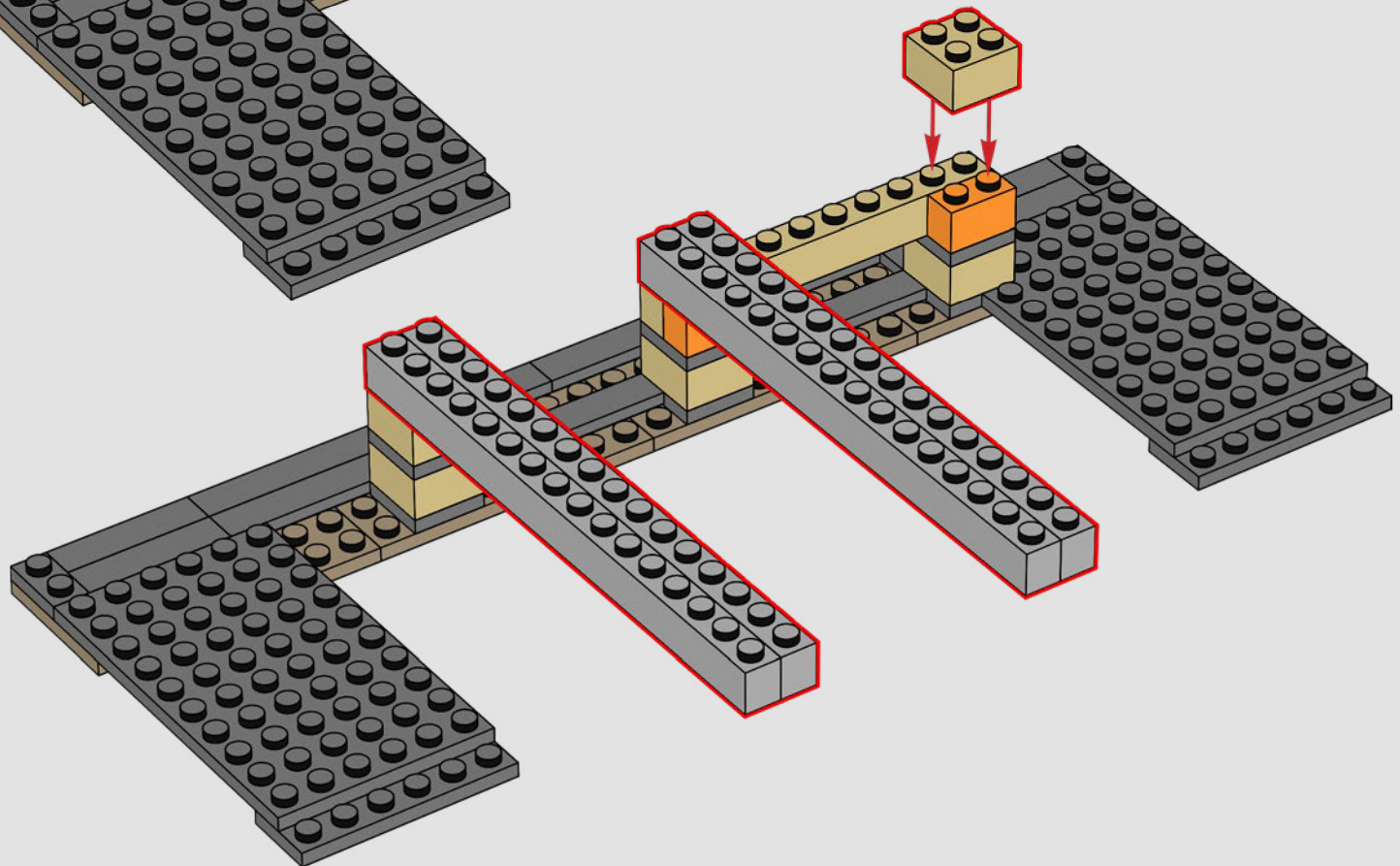

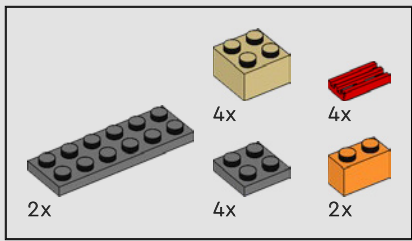

27

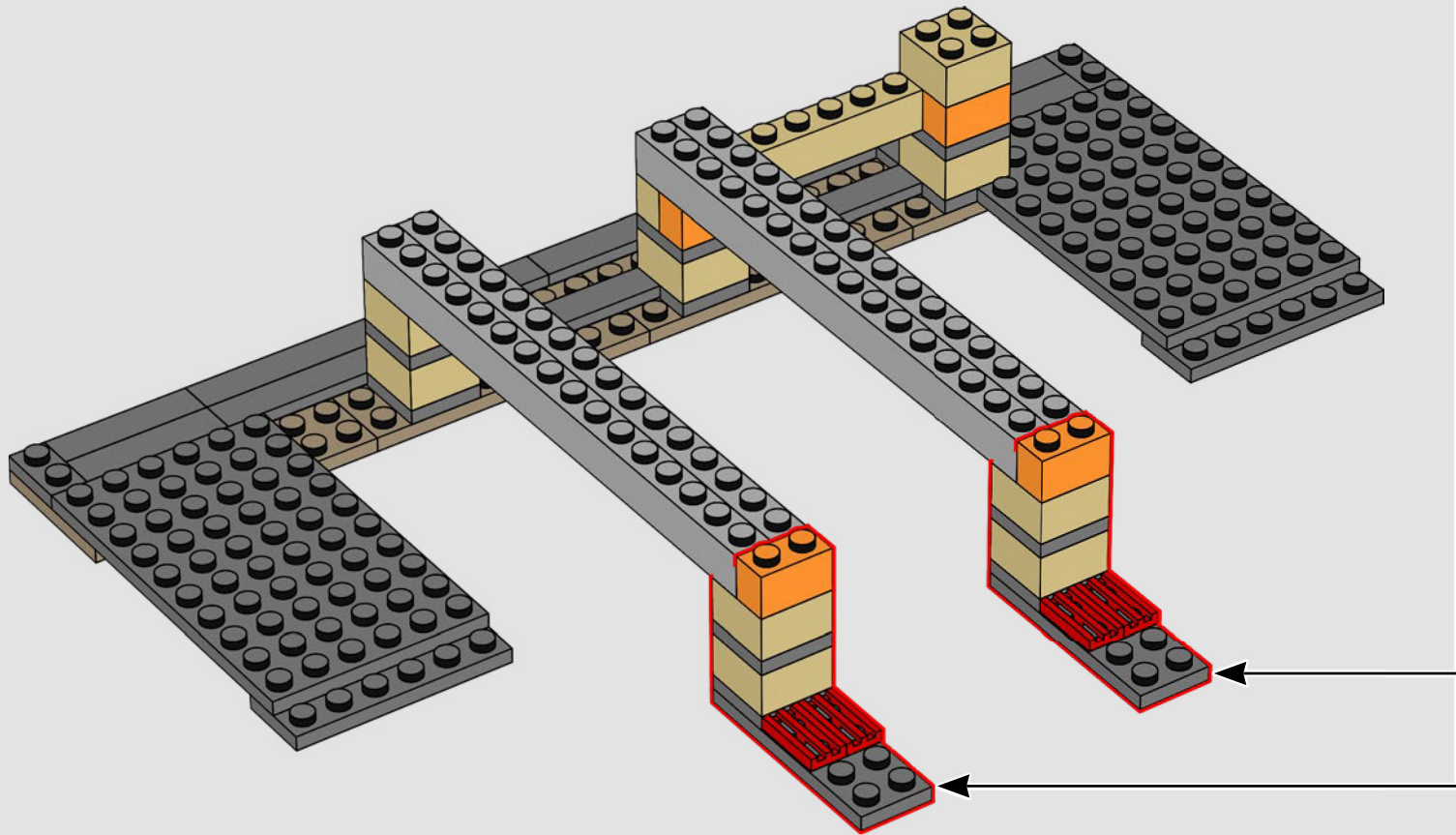
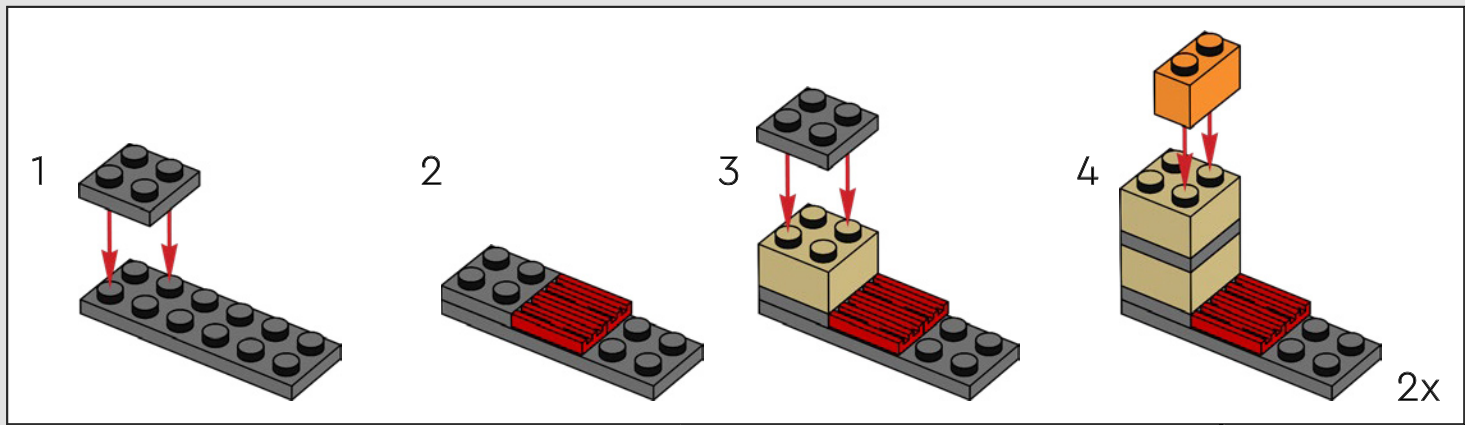

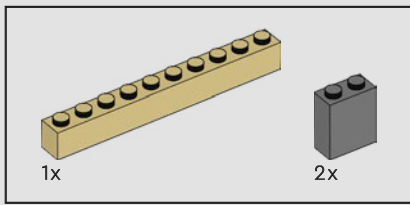

28

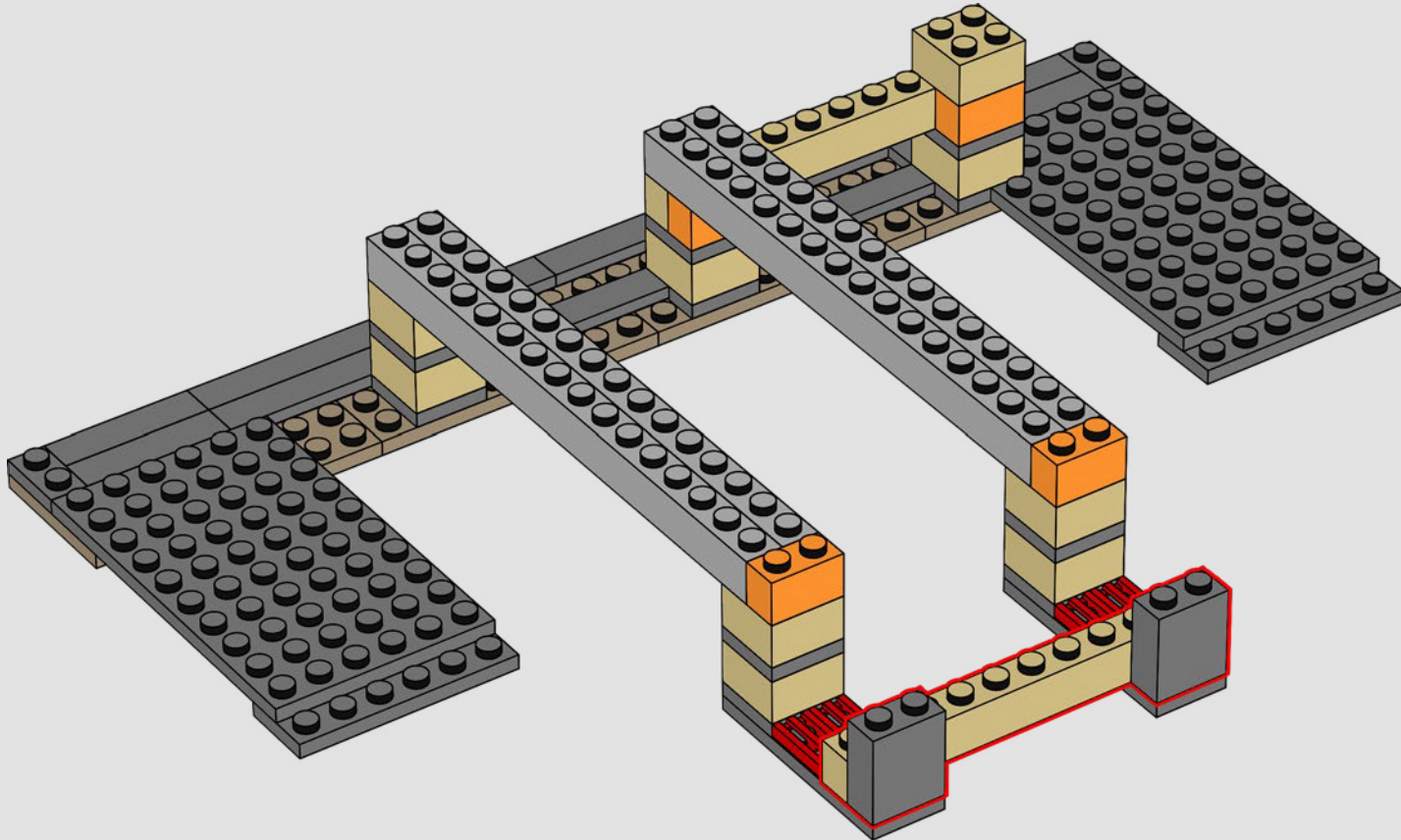

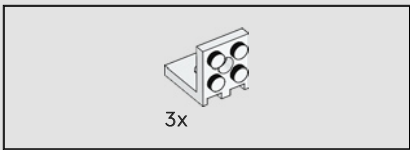

29

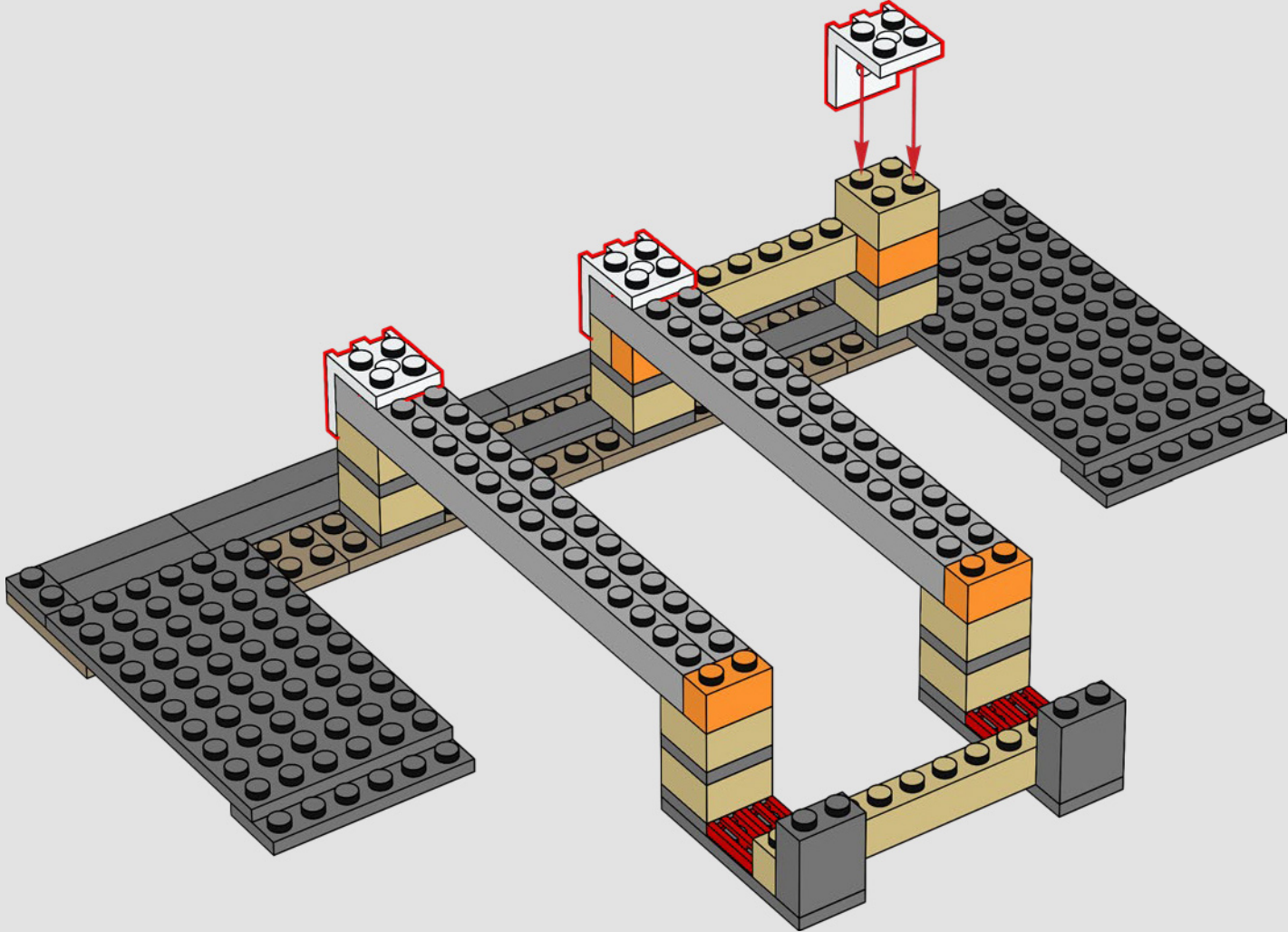

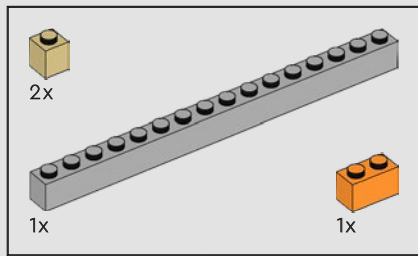

30

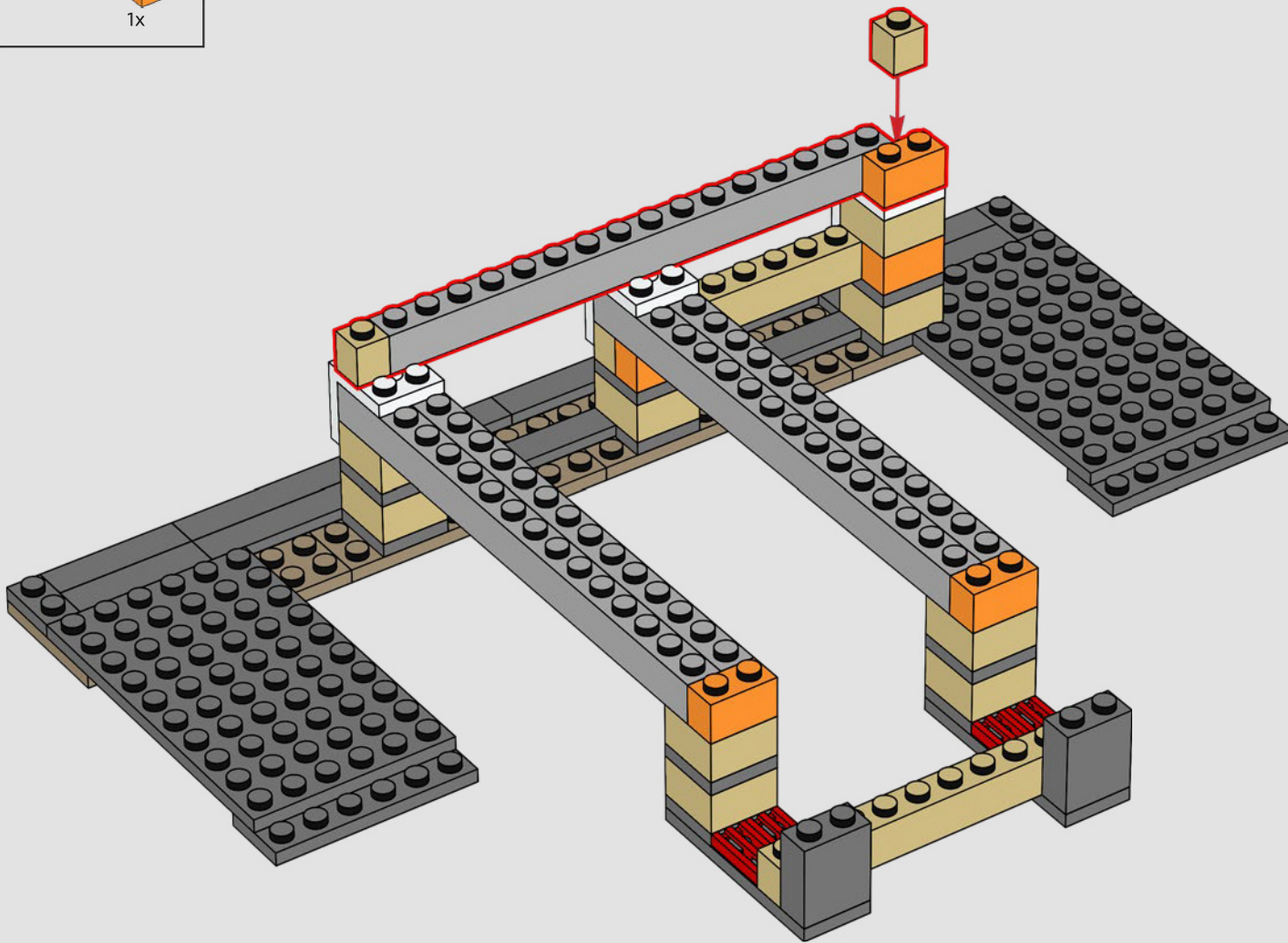

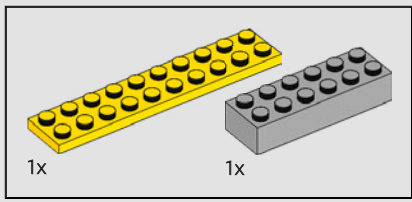

31

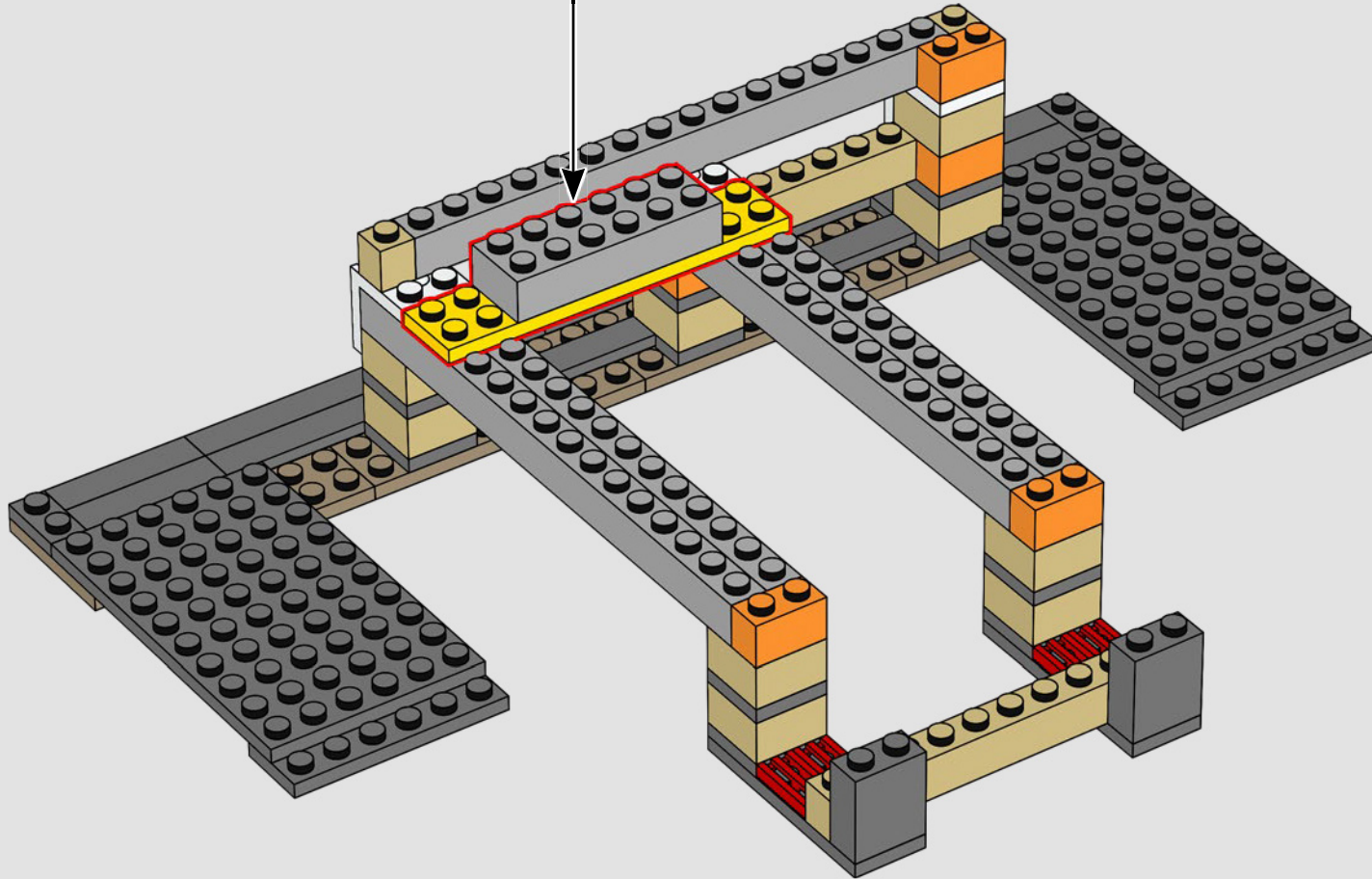
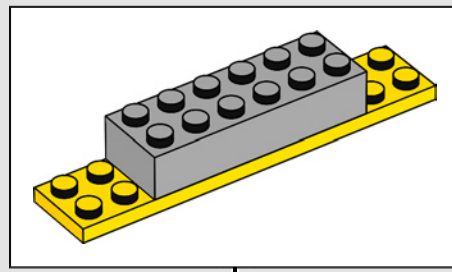



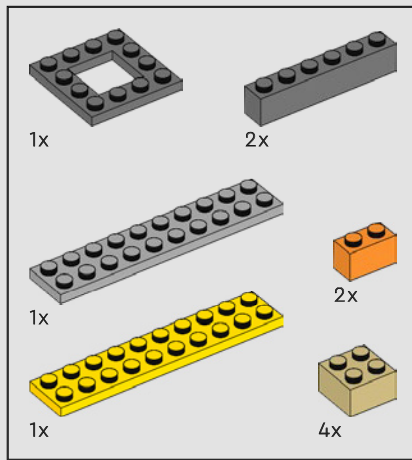

32

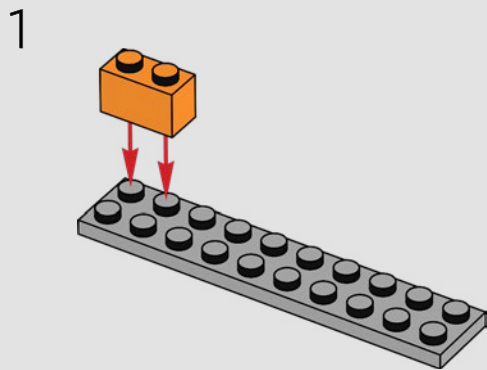

2

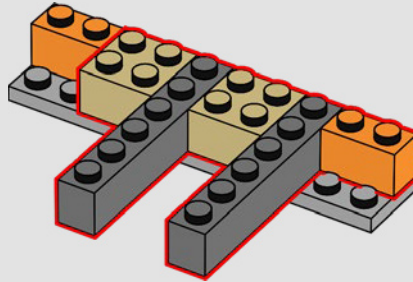

3

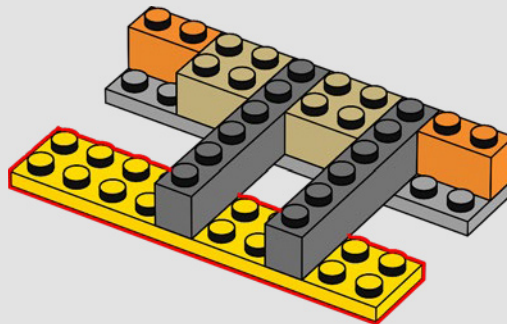

4

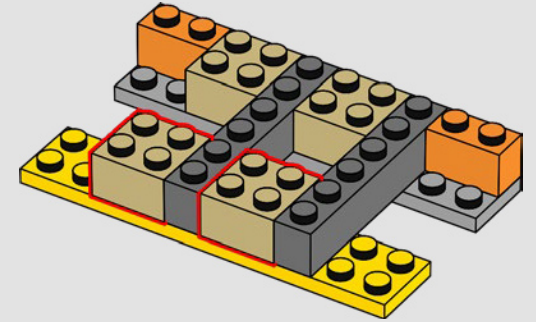

5

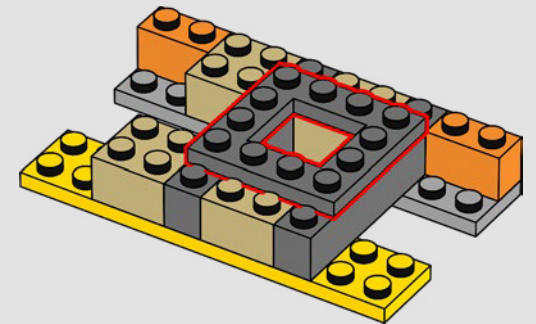

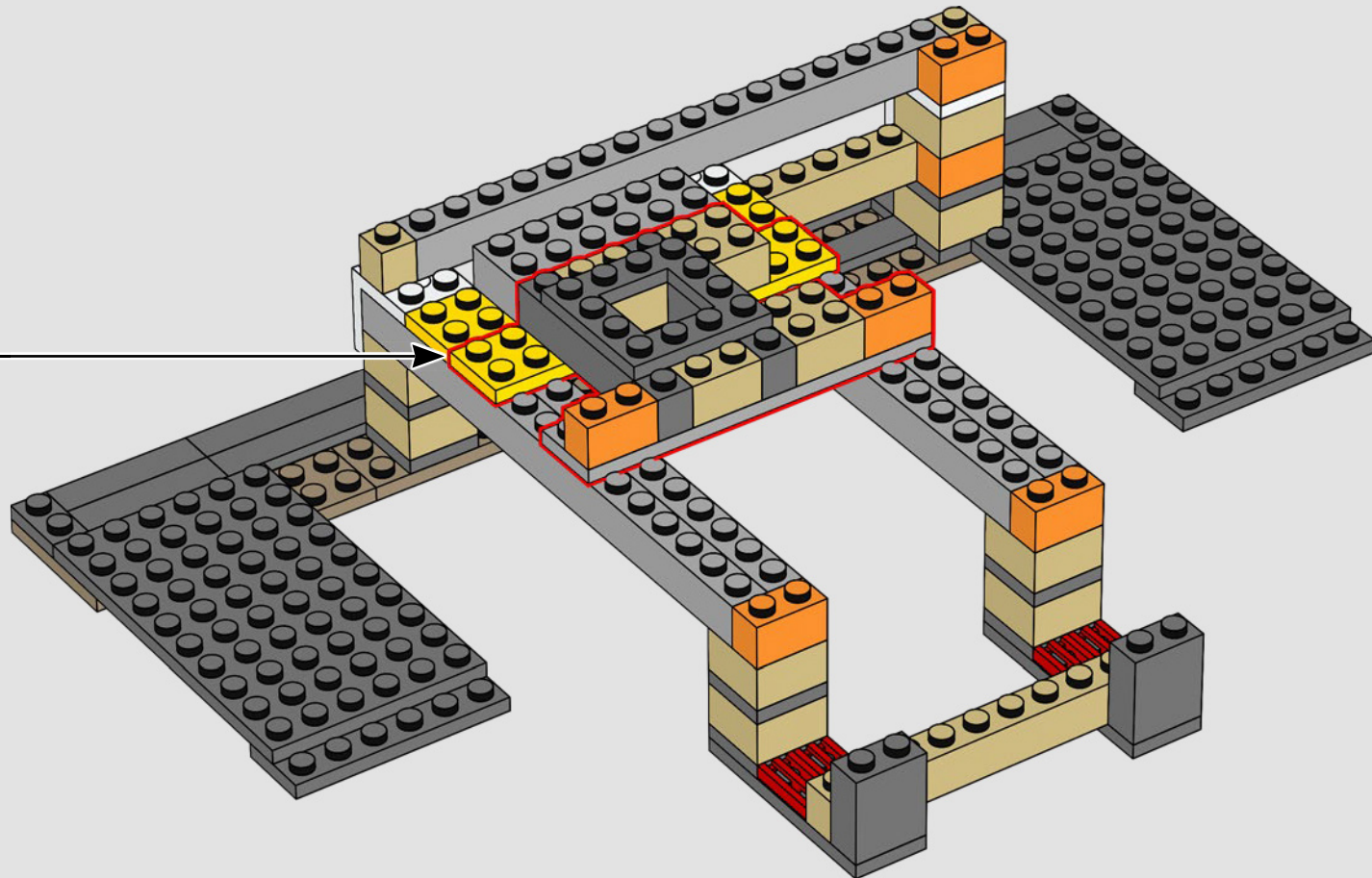

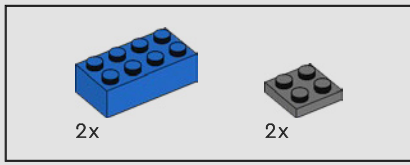

33

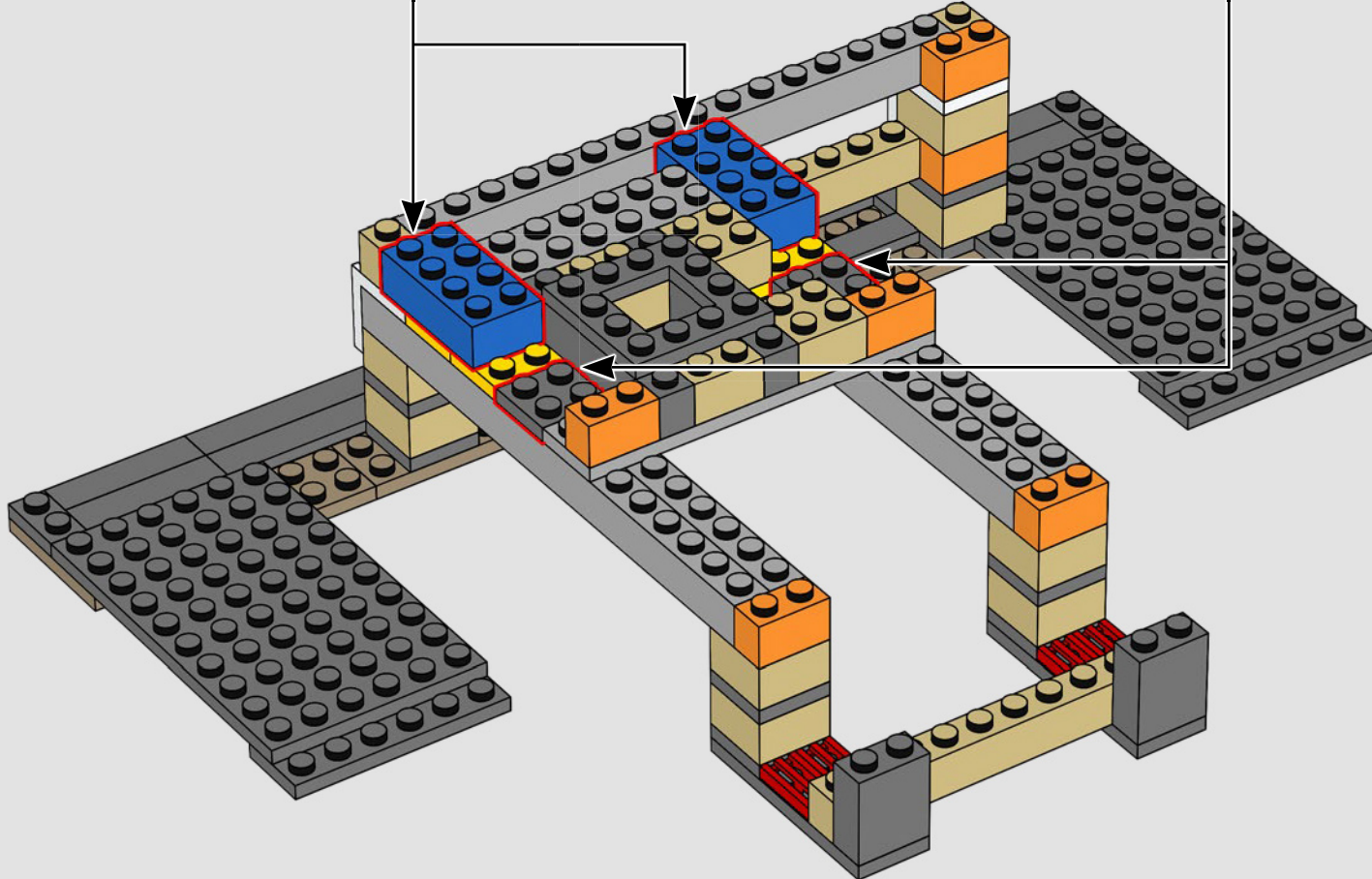
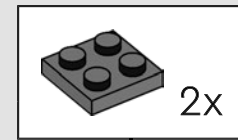
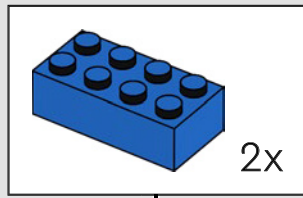

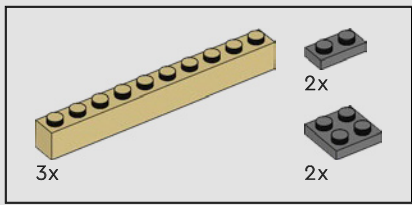

34

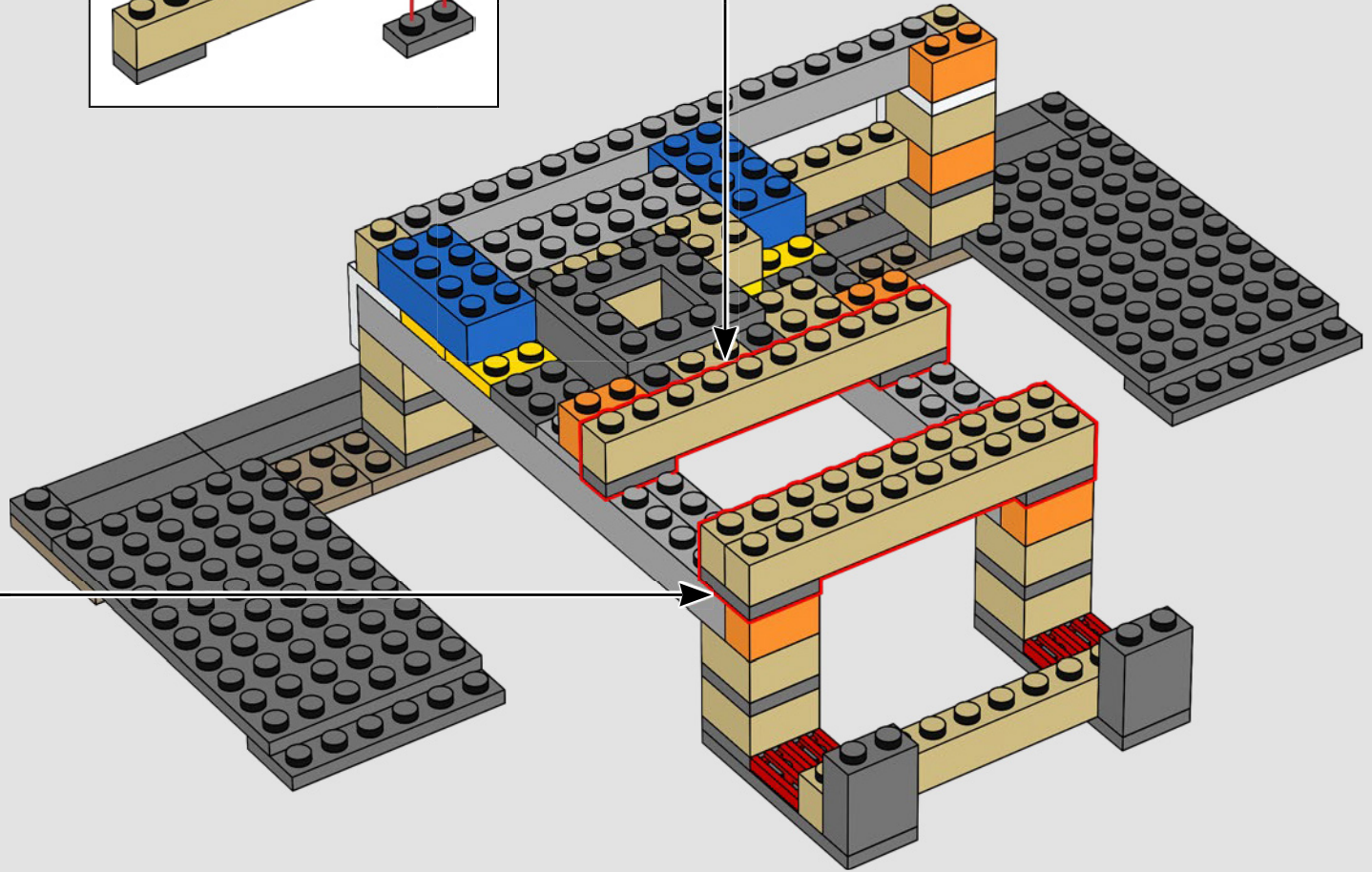
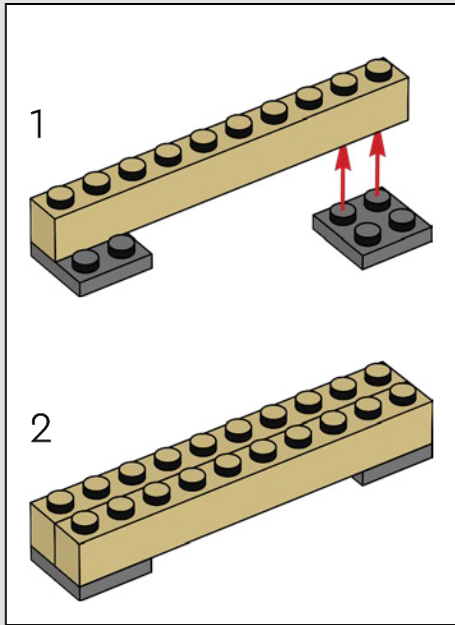
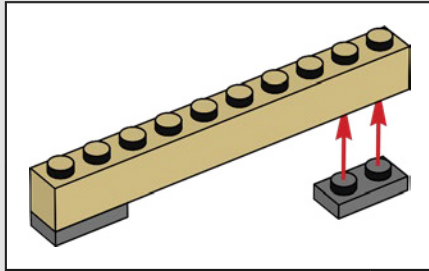

35

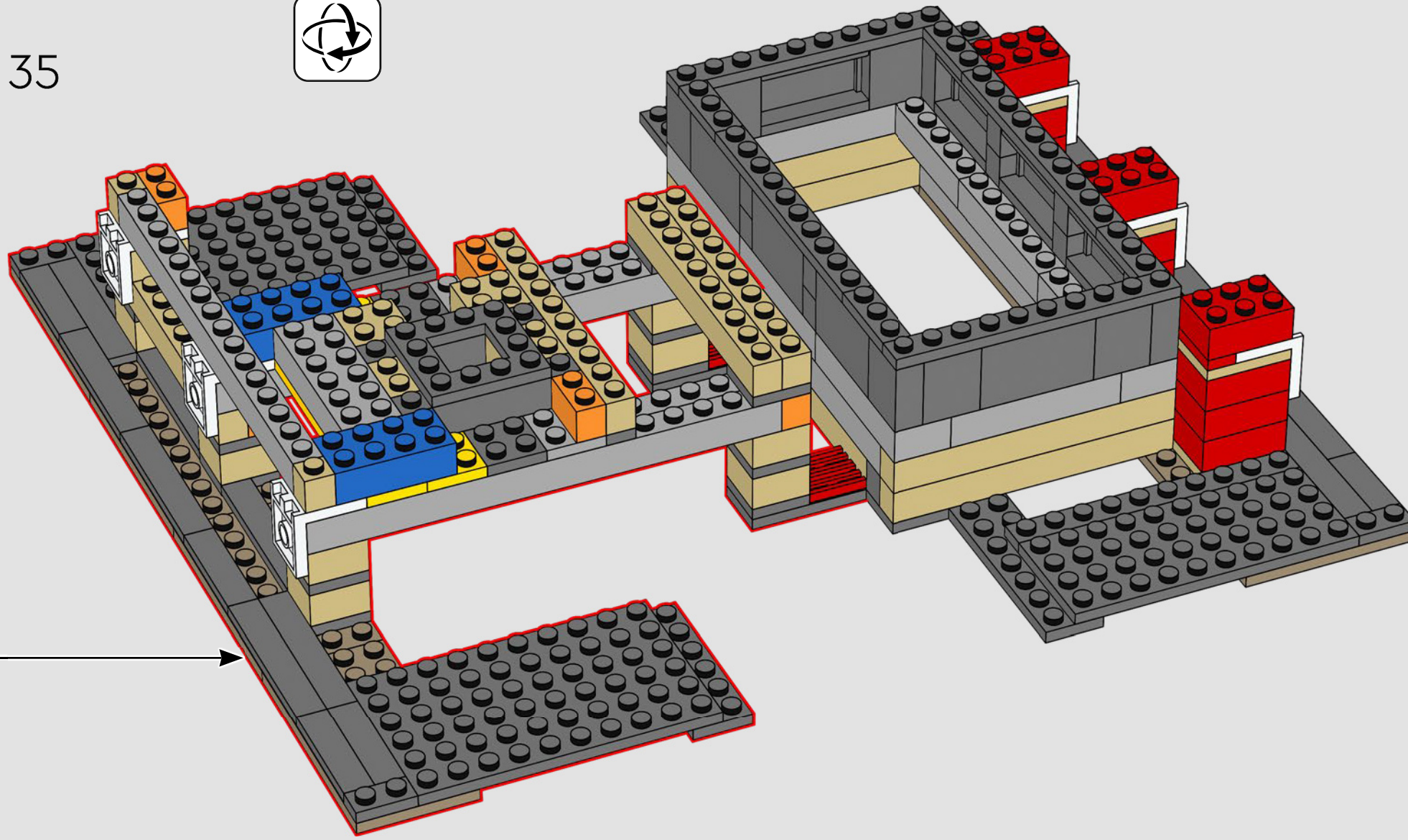

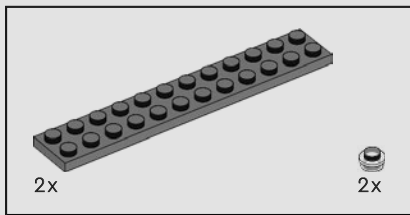

36

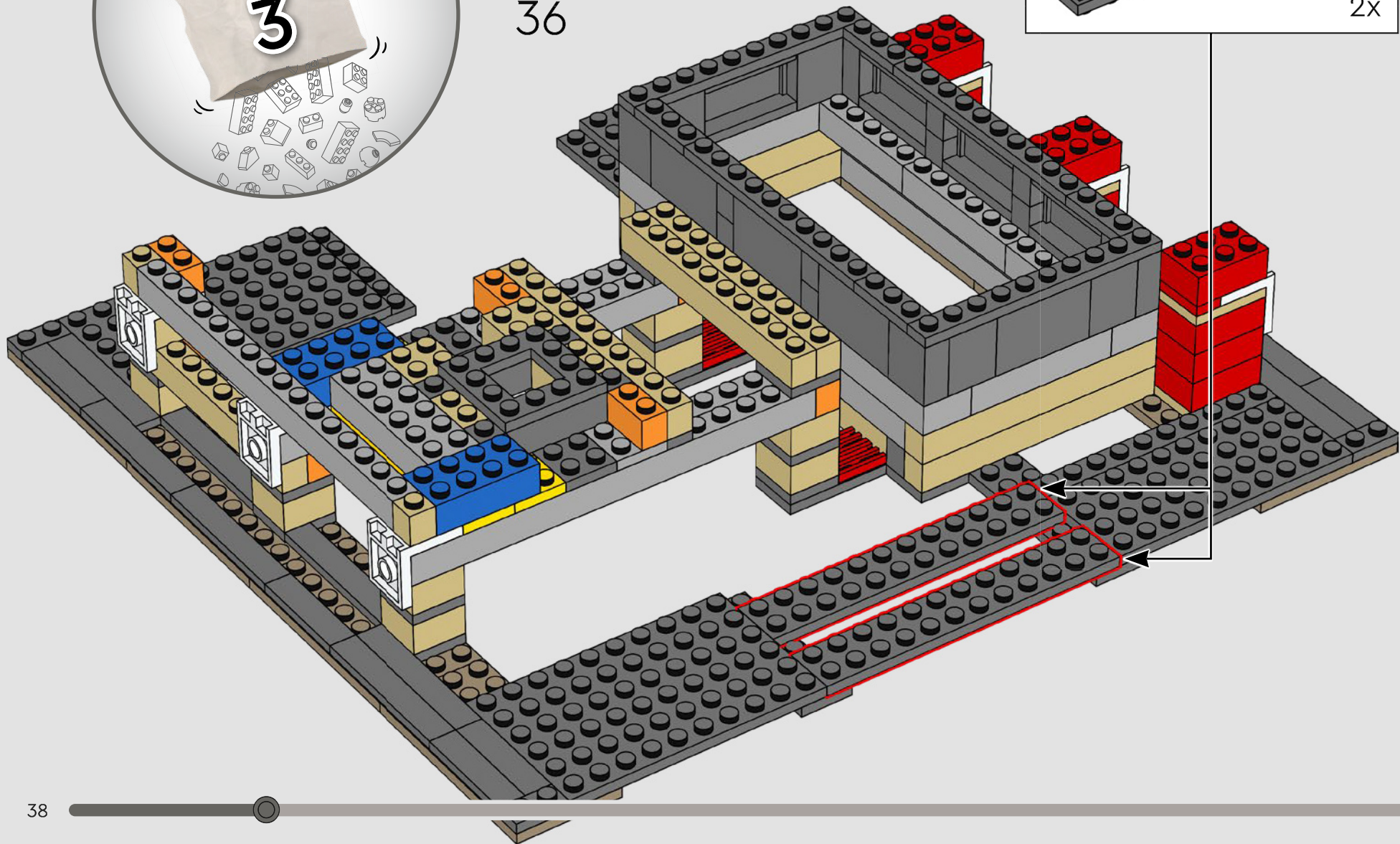
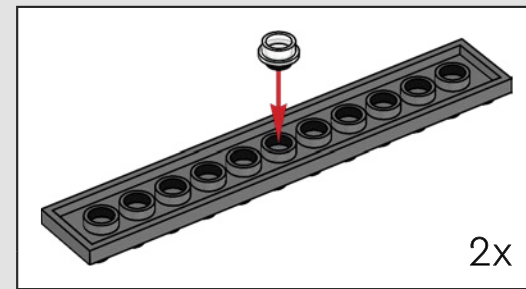

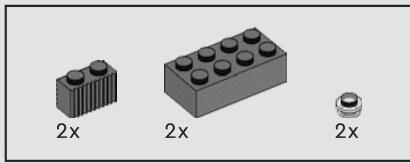

37

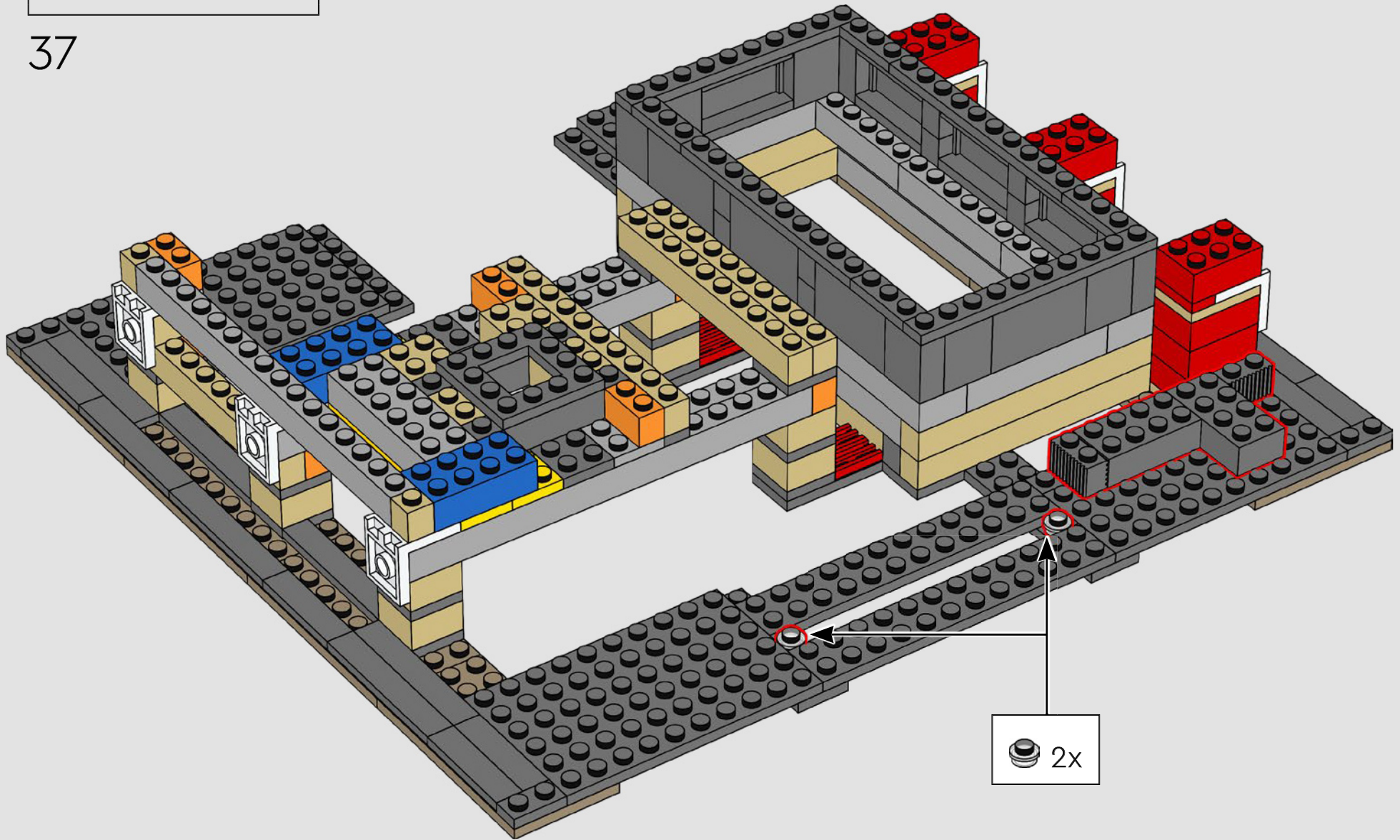

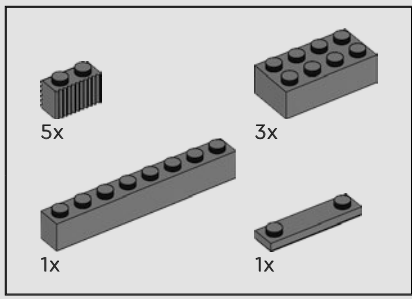

38

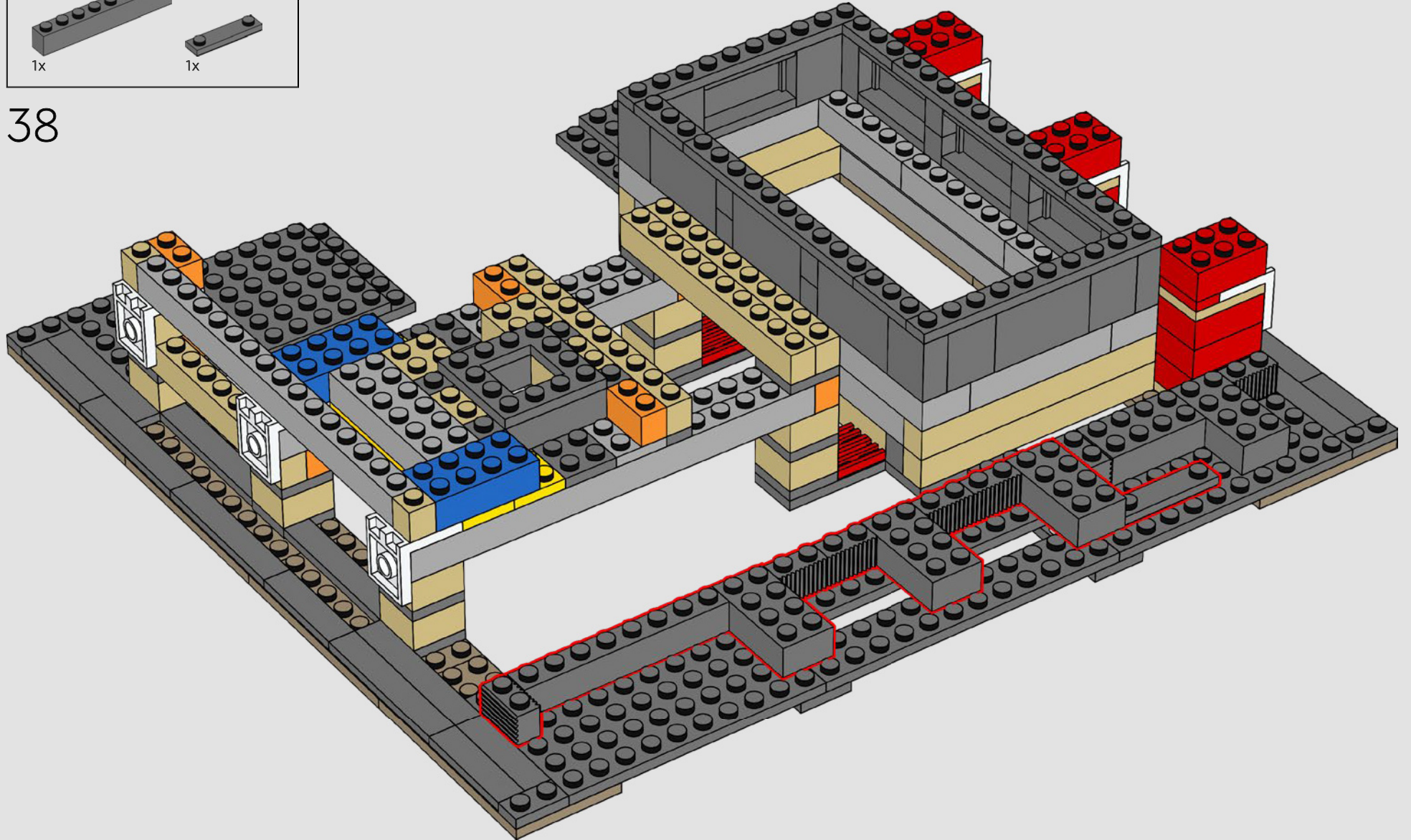



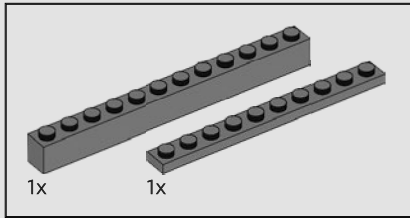
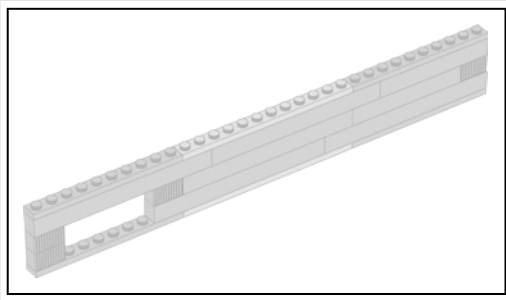

39

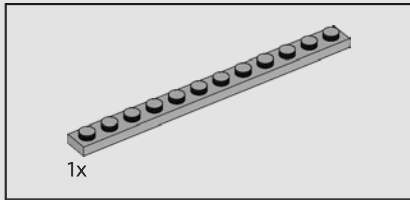

40

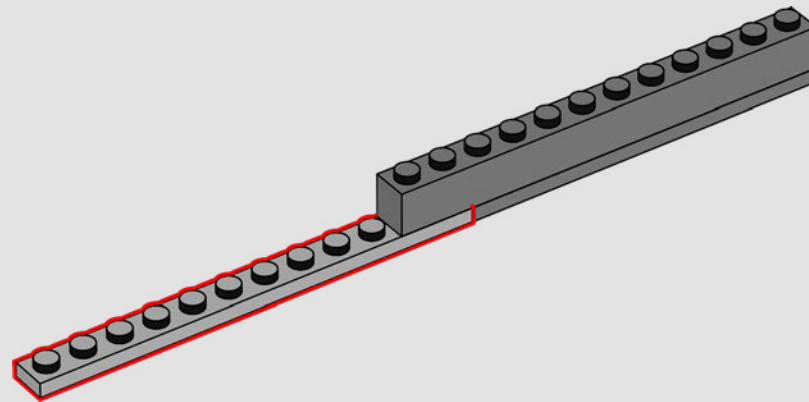
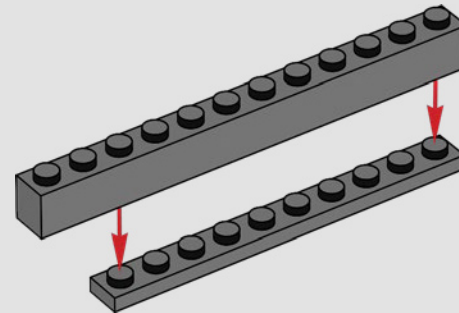

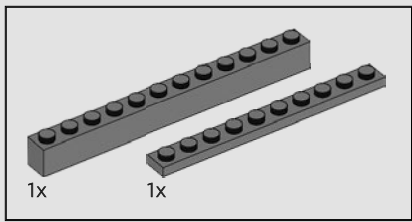

41

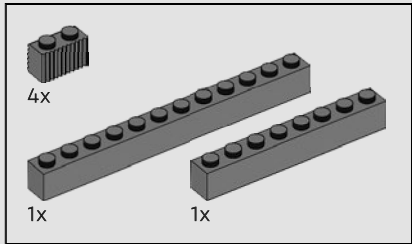
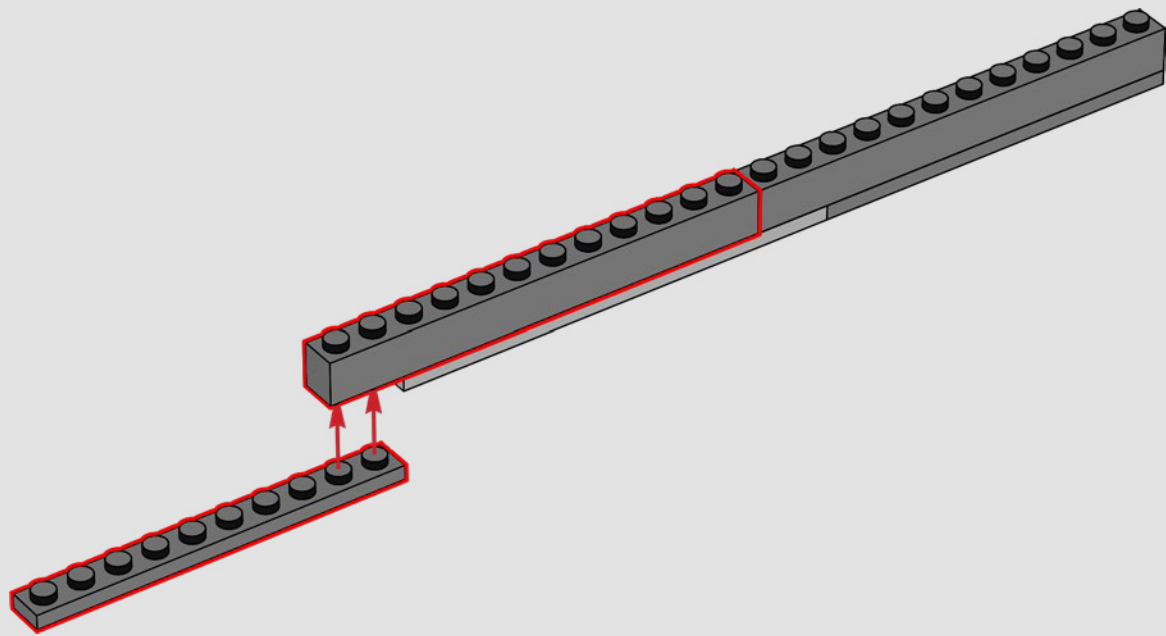

42

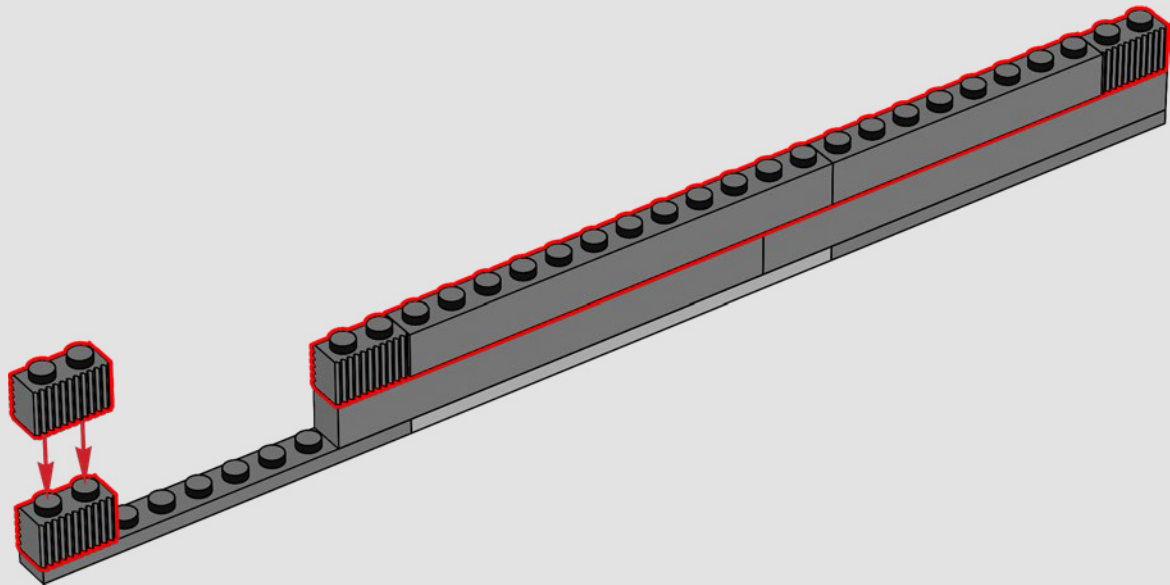

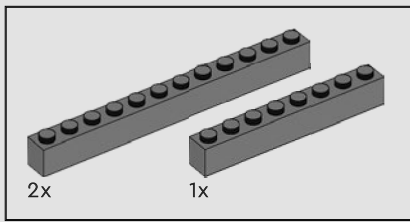

43

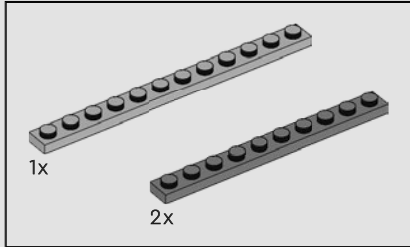
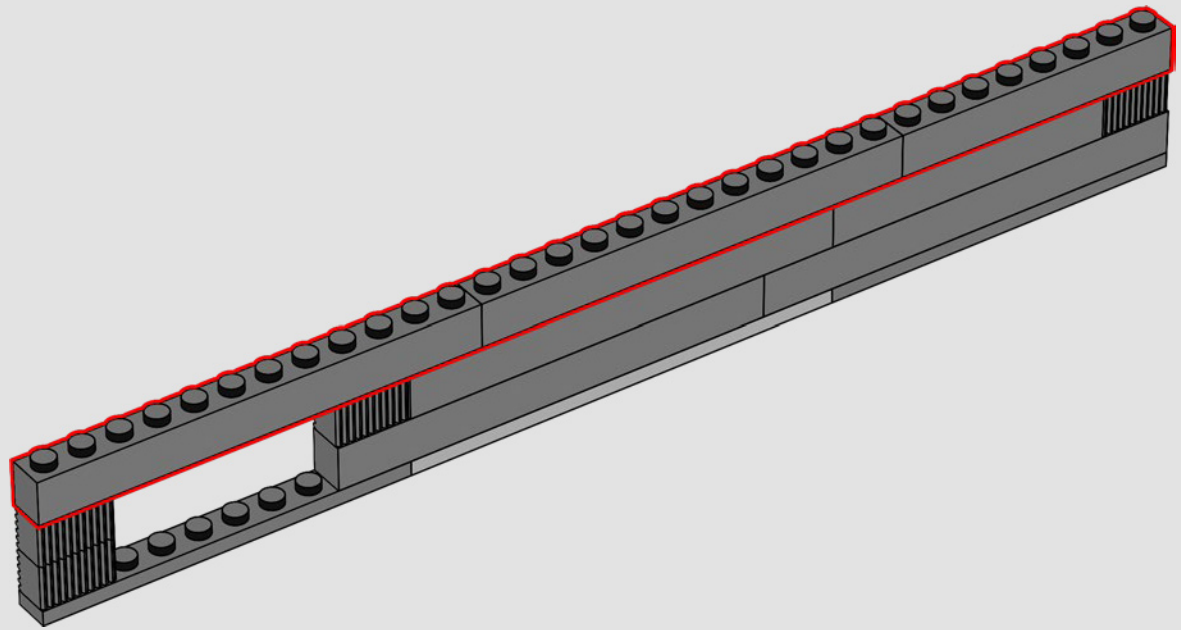

44

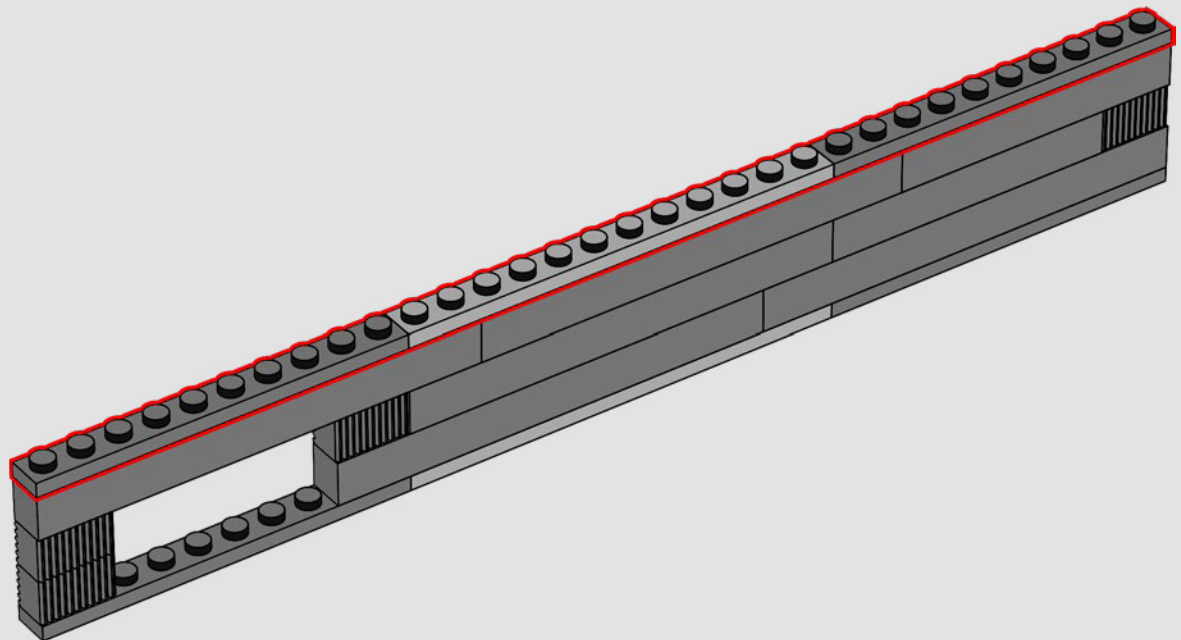

45

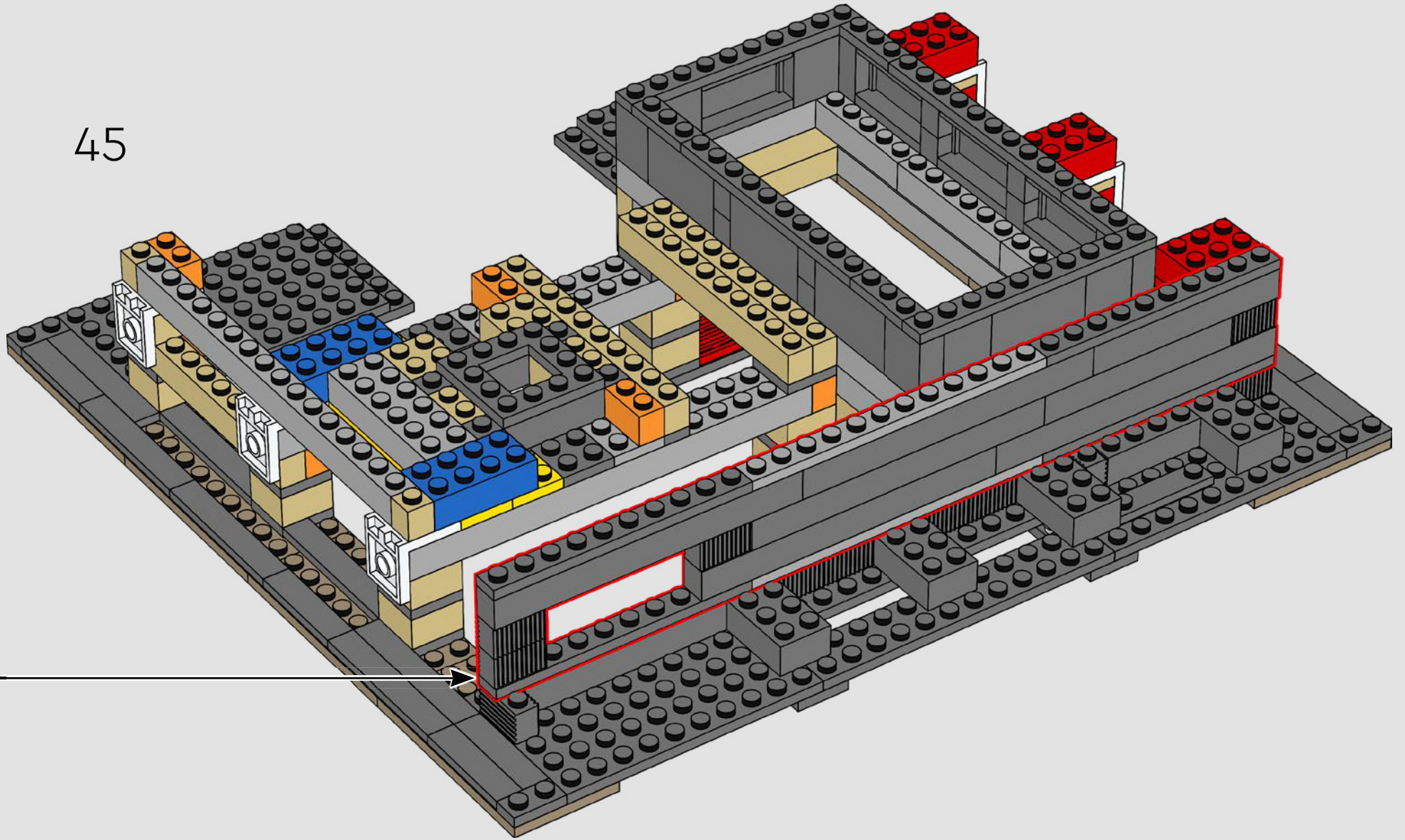

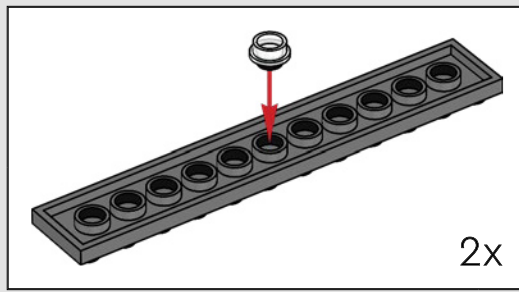
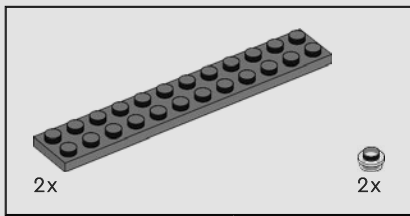

46

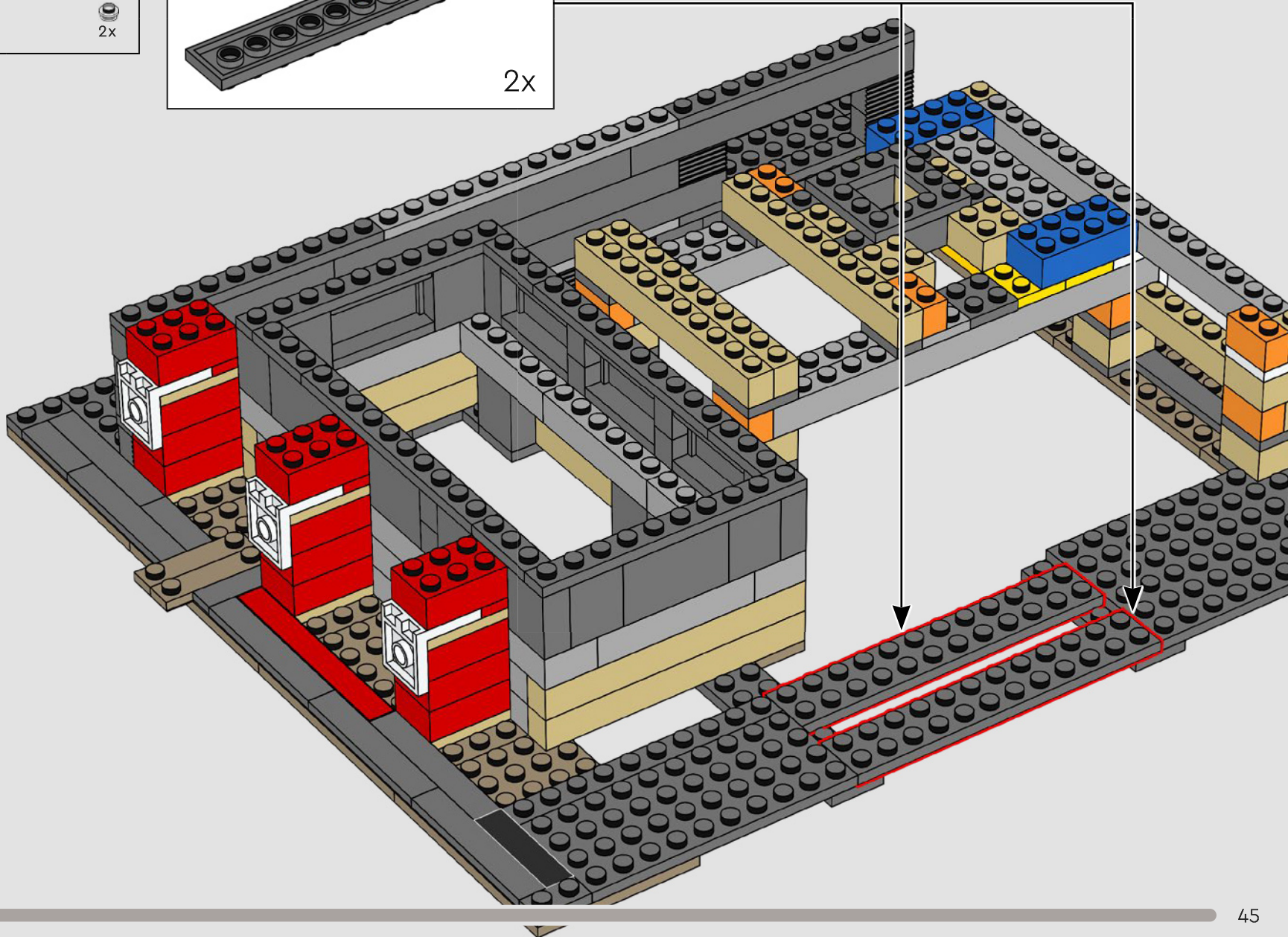

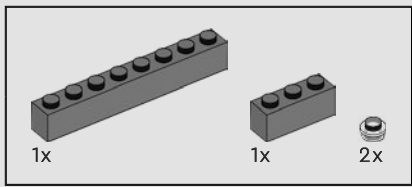

47

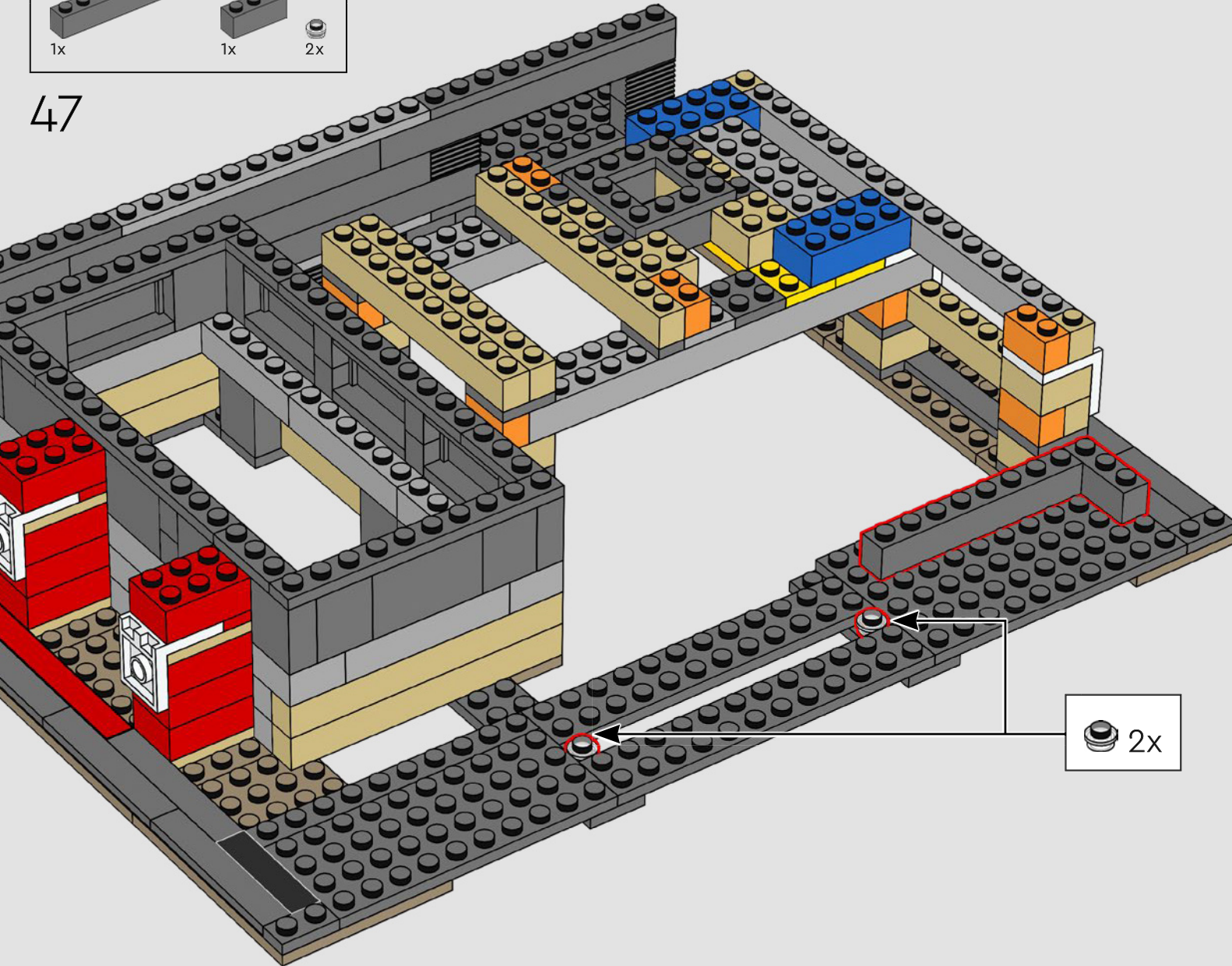

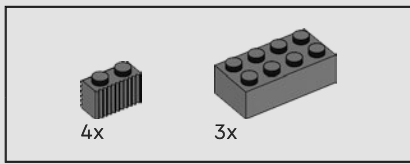

48

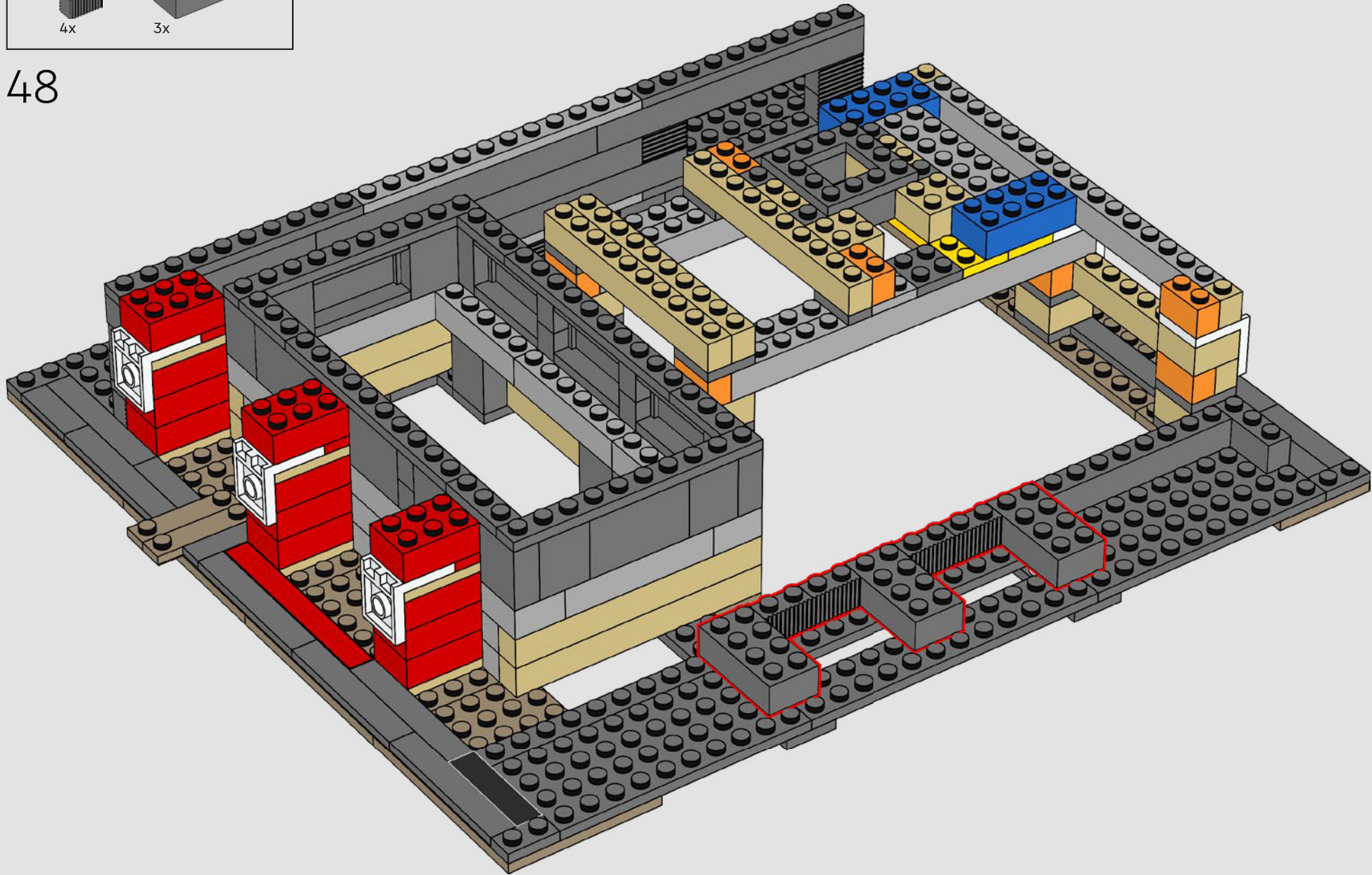

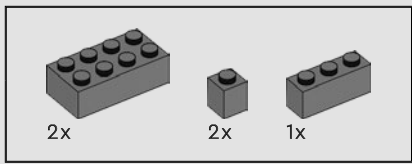

49

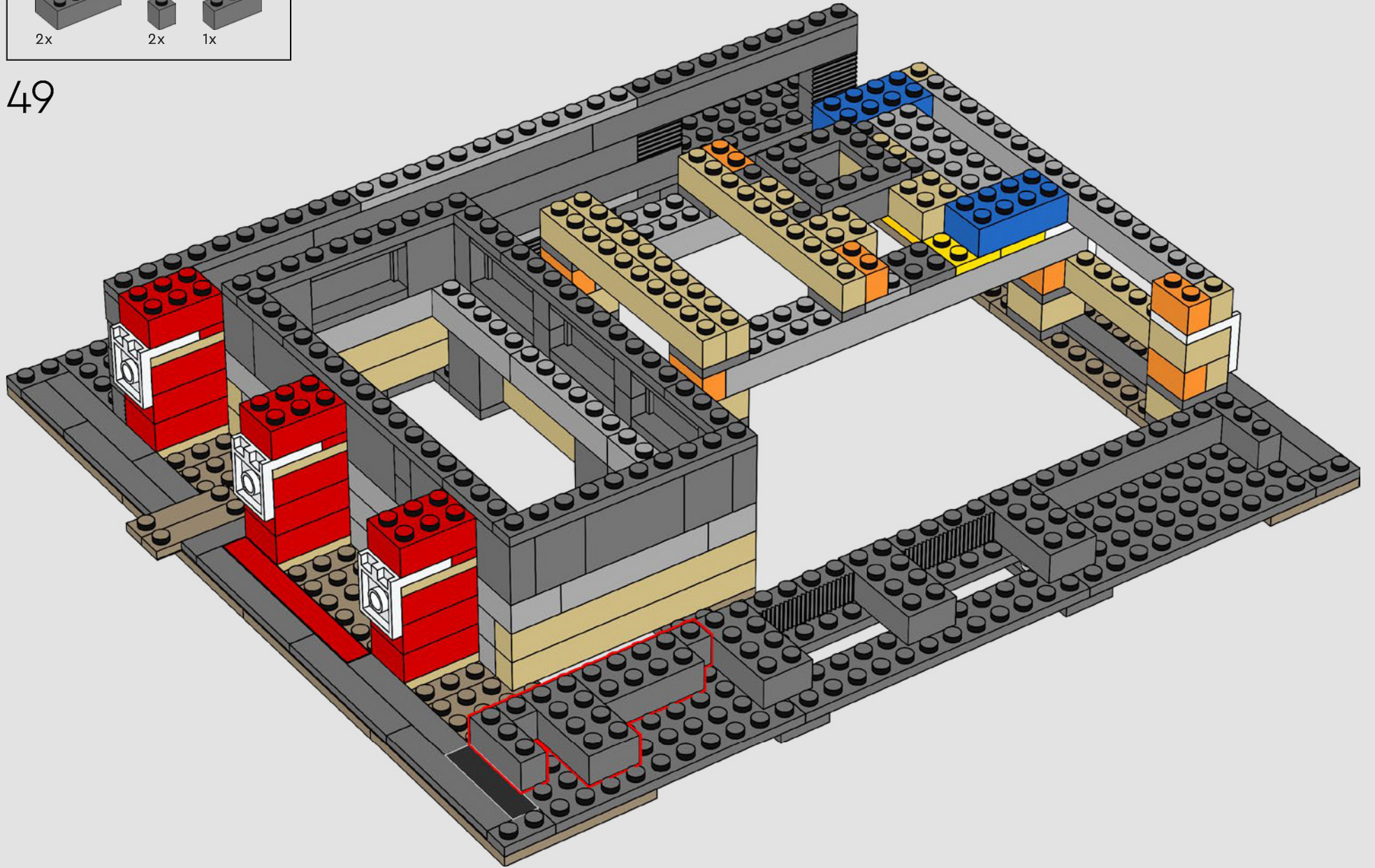



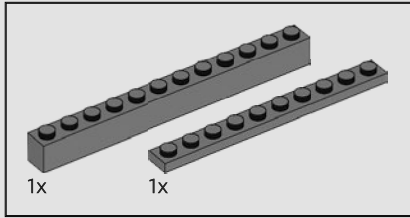
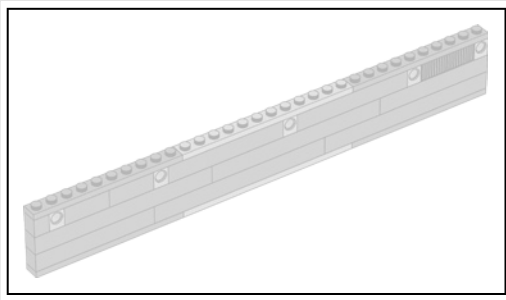

50

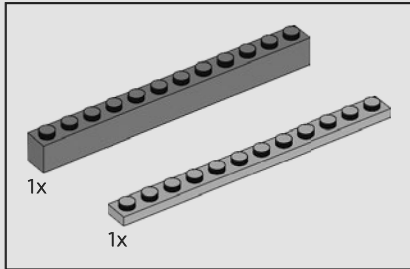

51

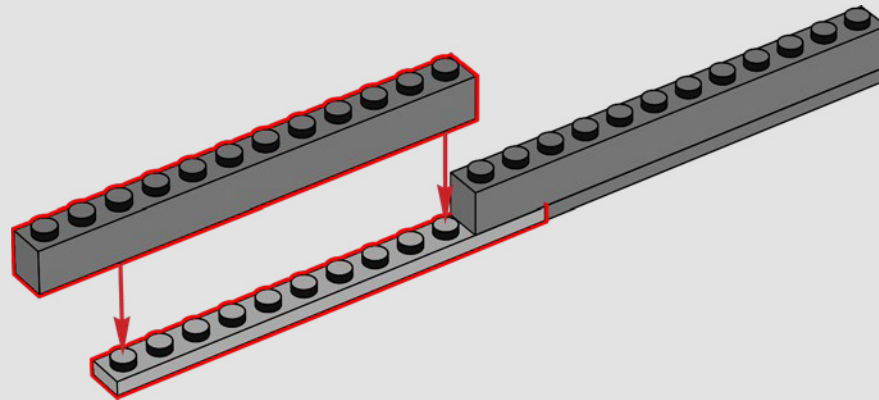
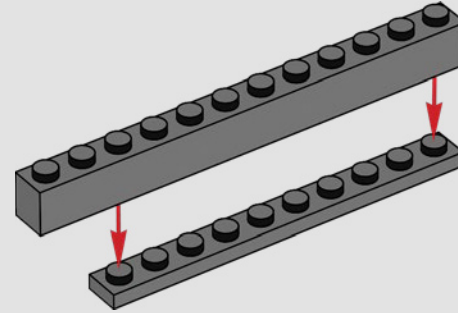

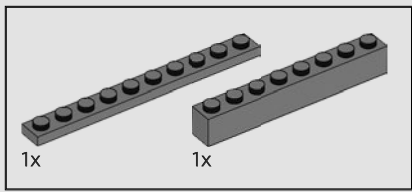

52

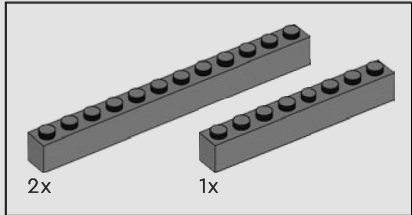
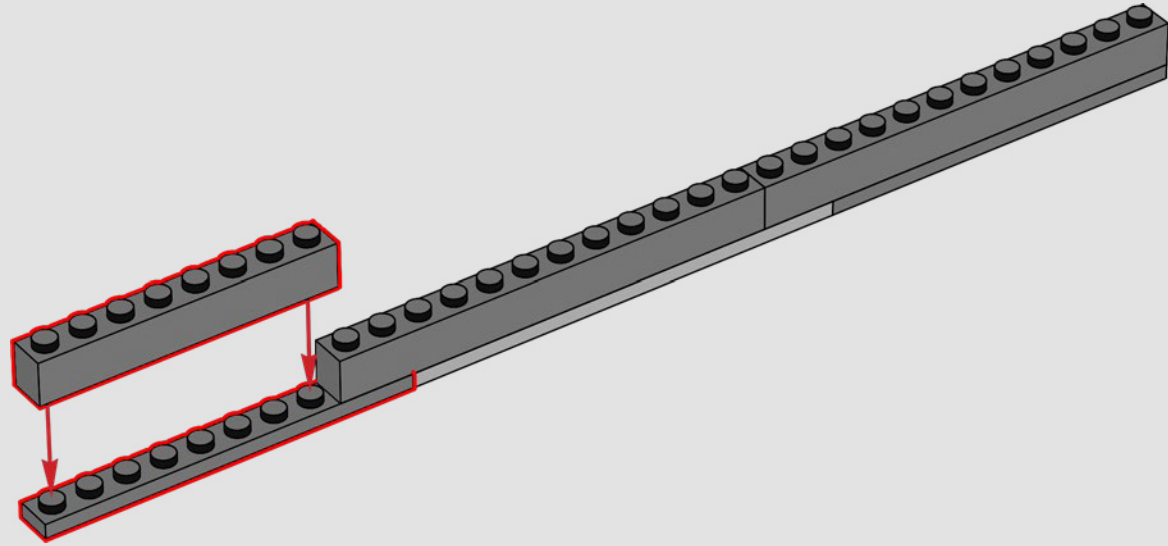

53

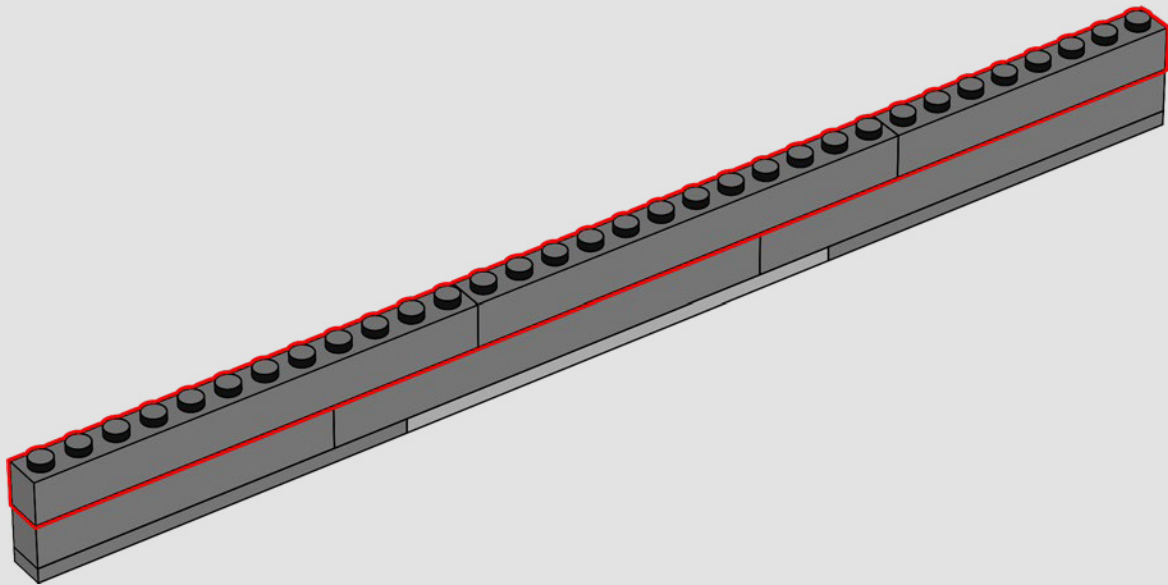

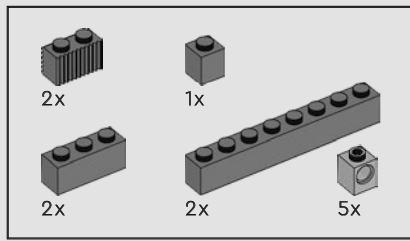

54

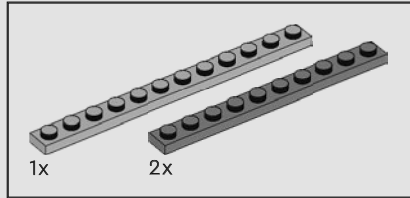
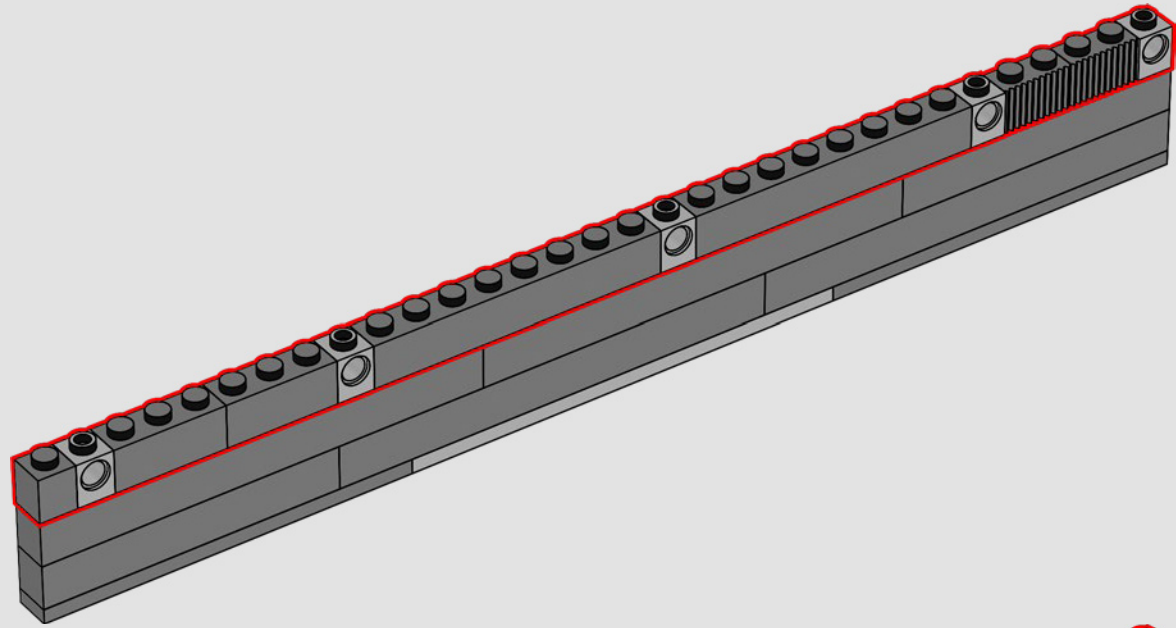

55

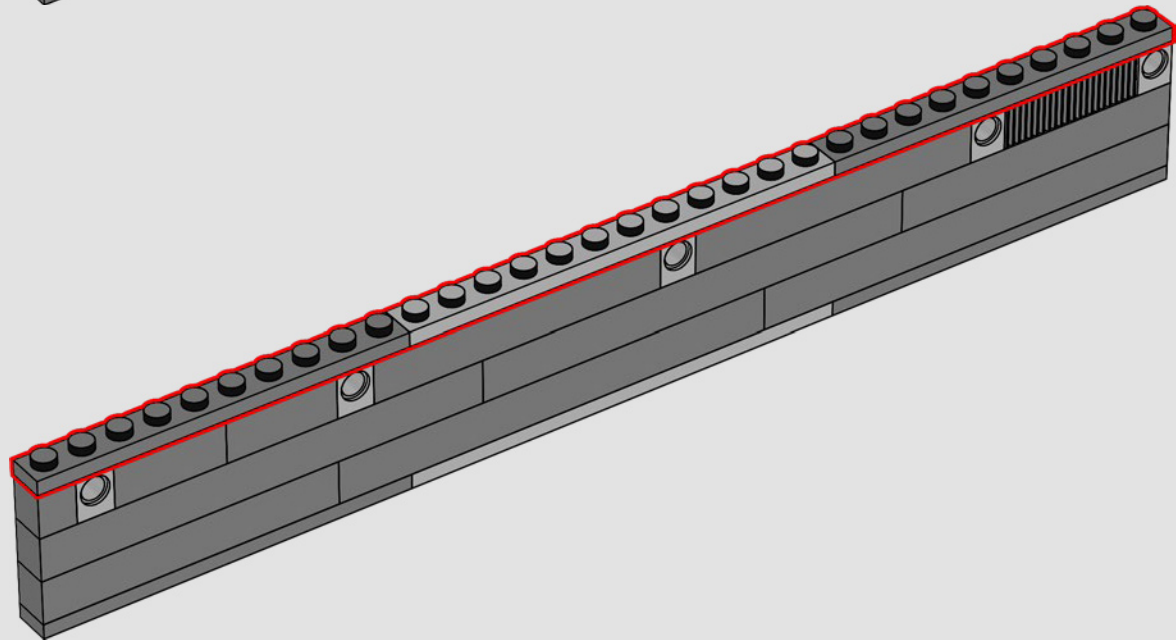

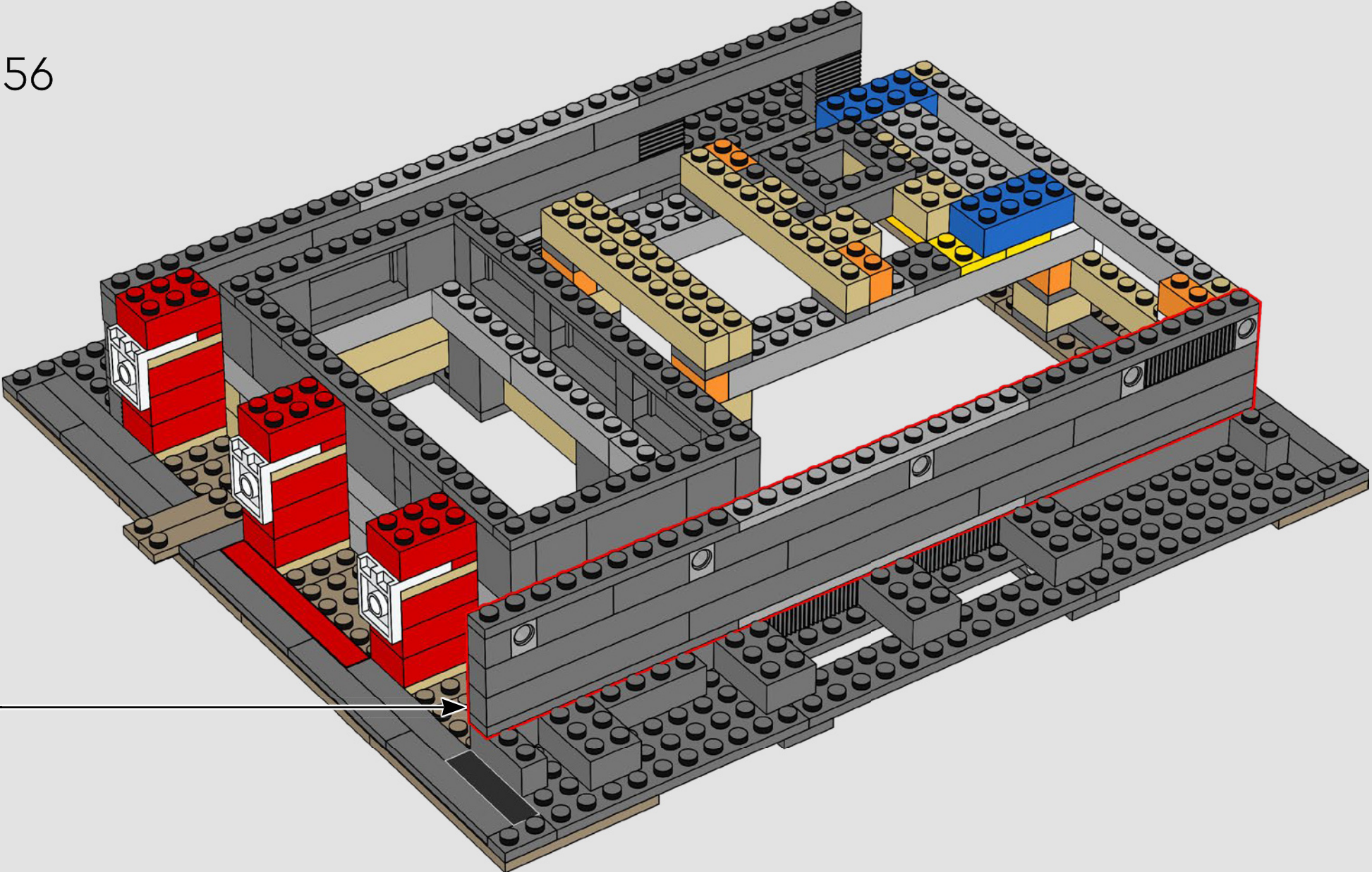

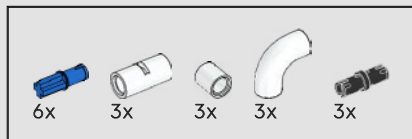

57

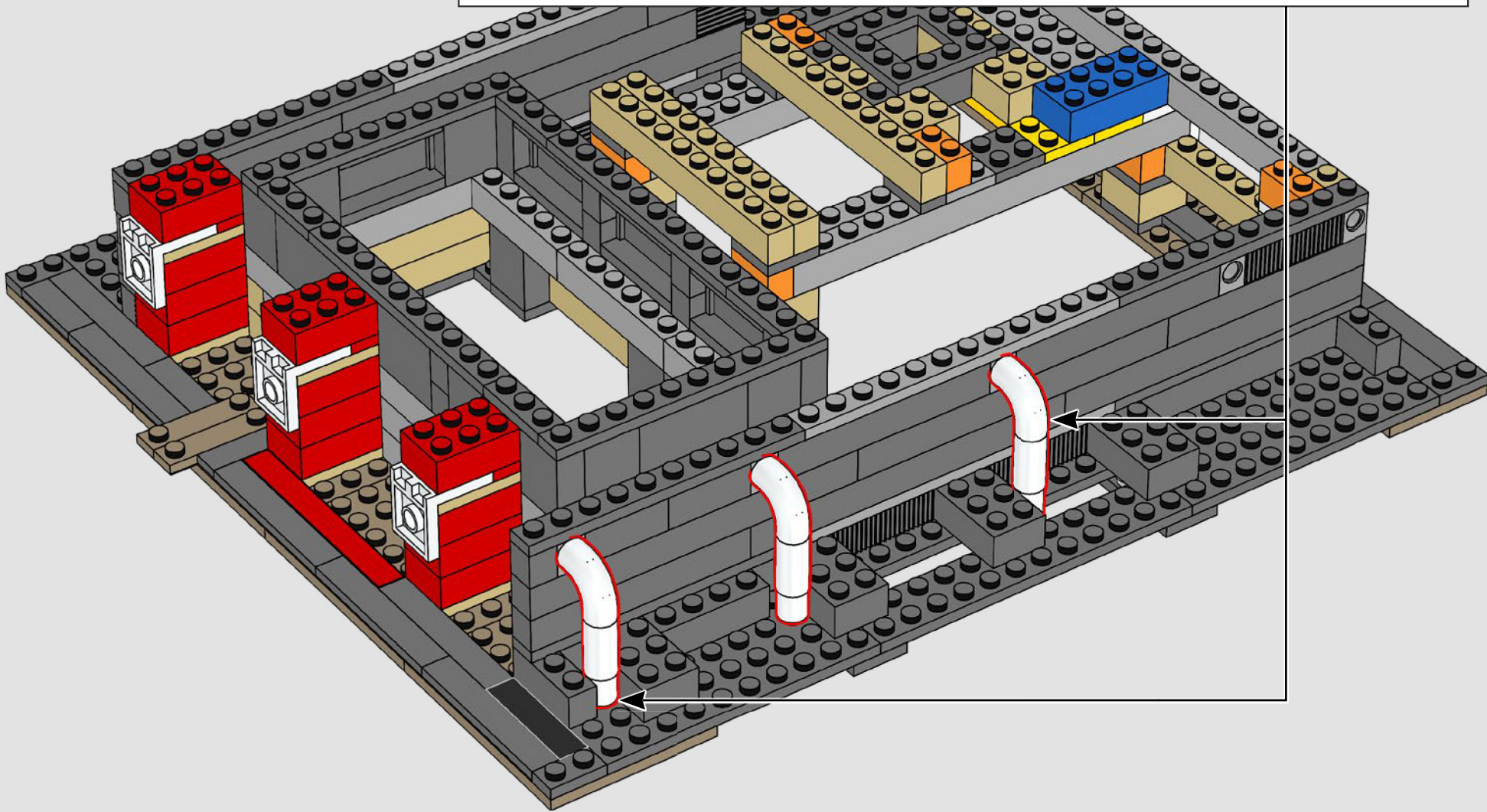
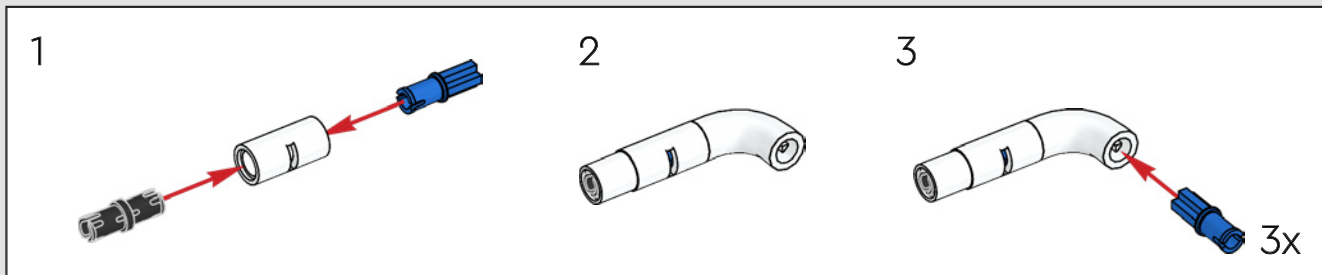

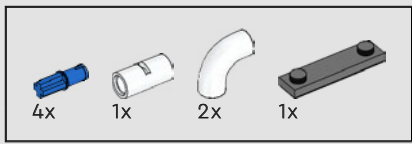

58

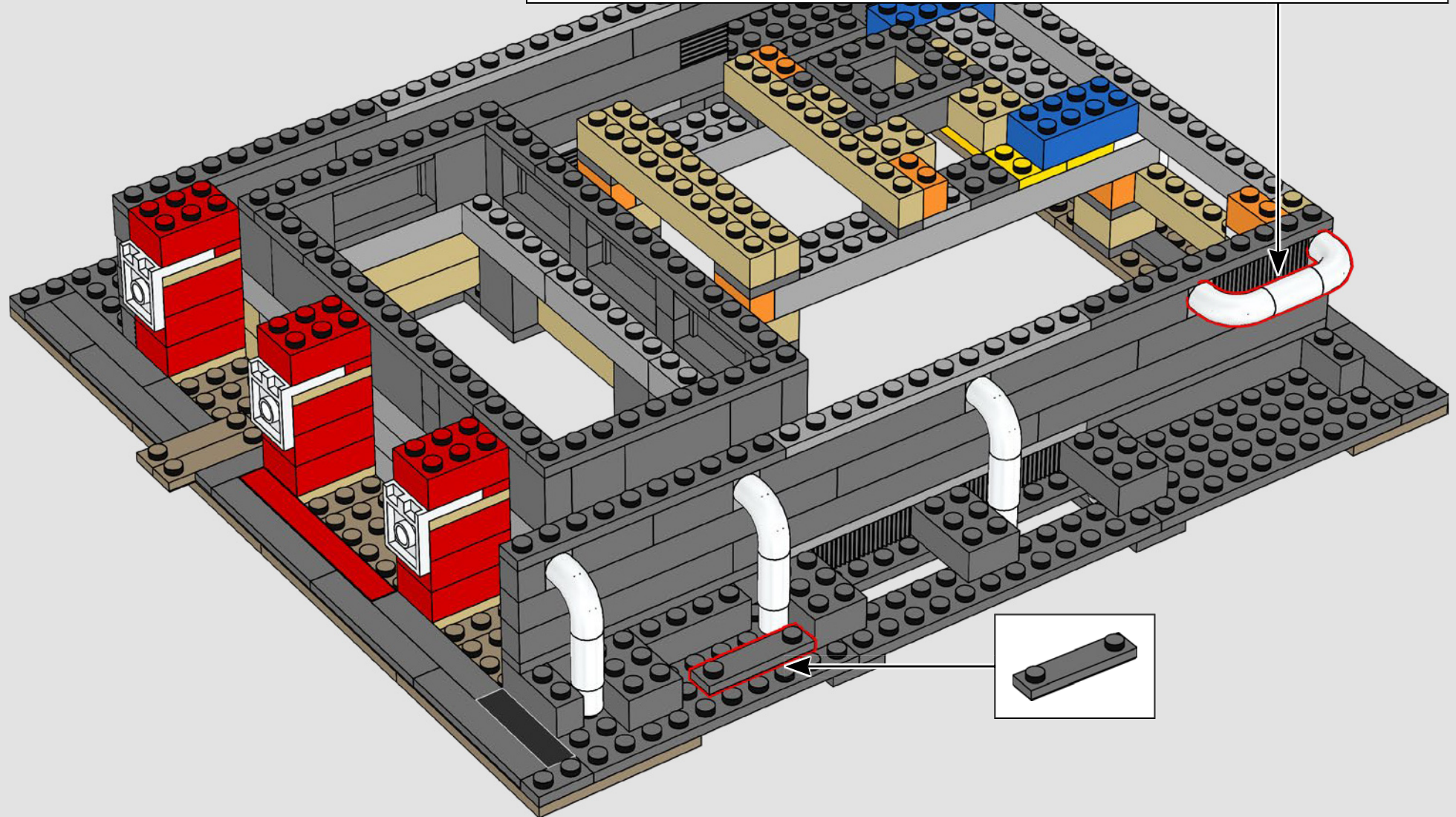
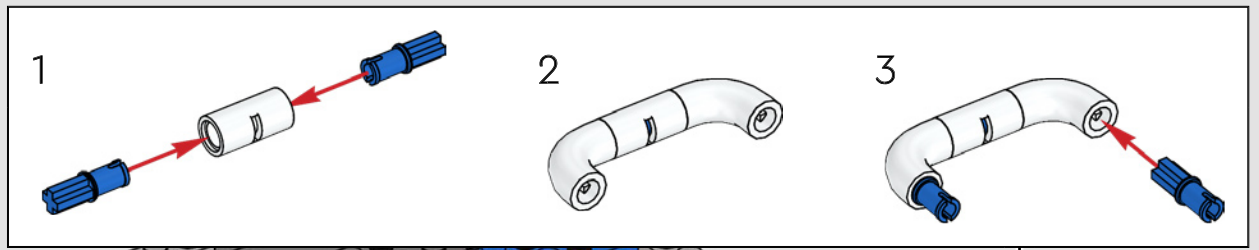

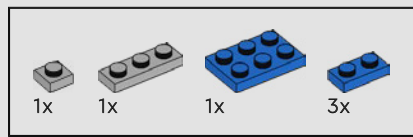

59

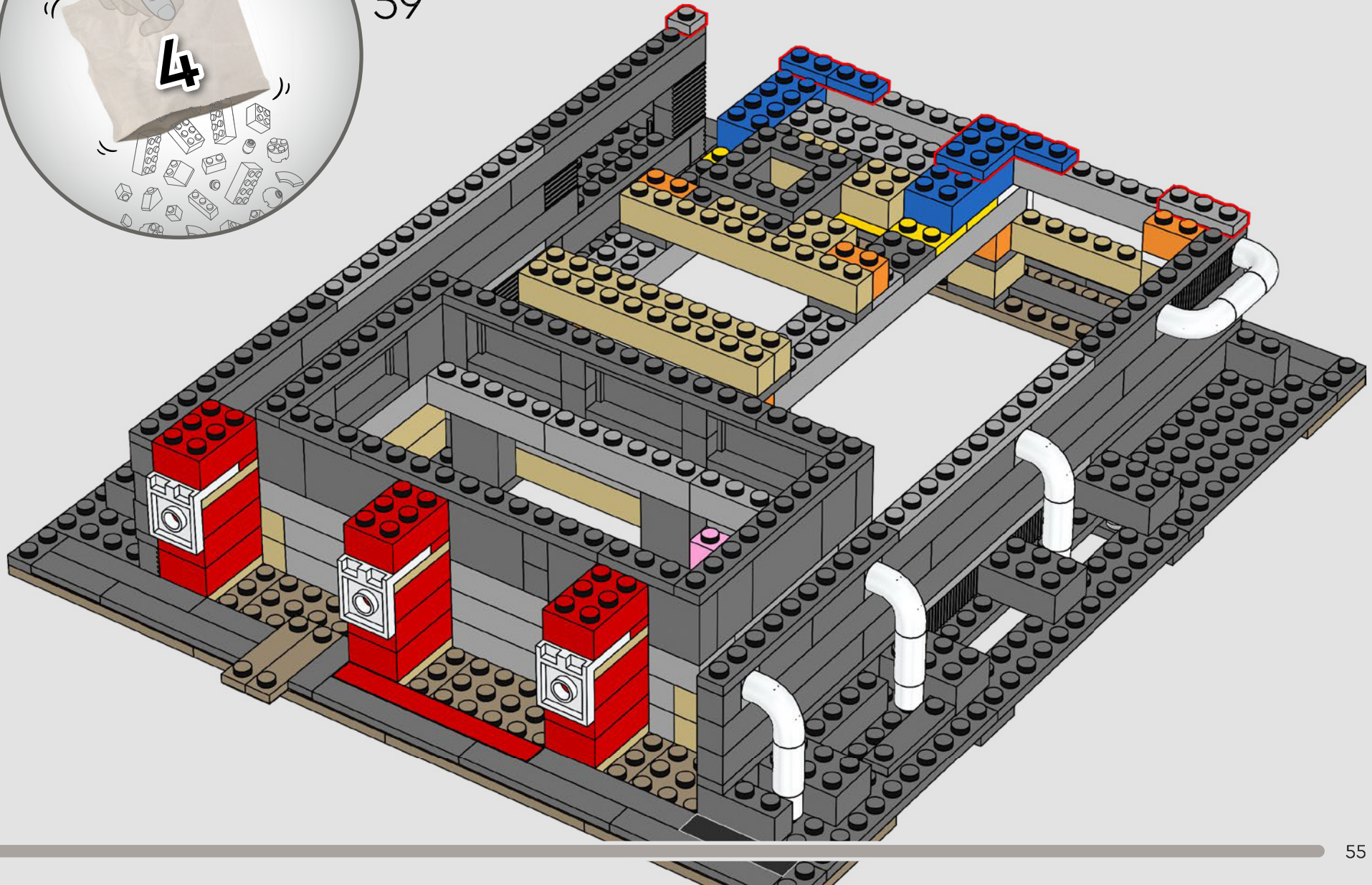

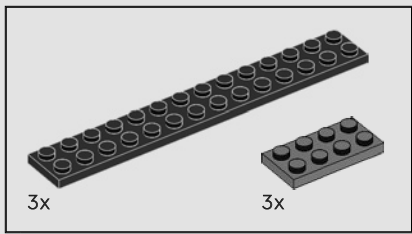

60

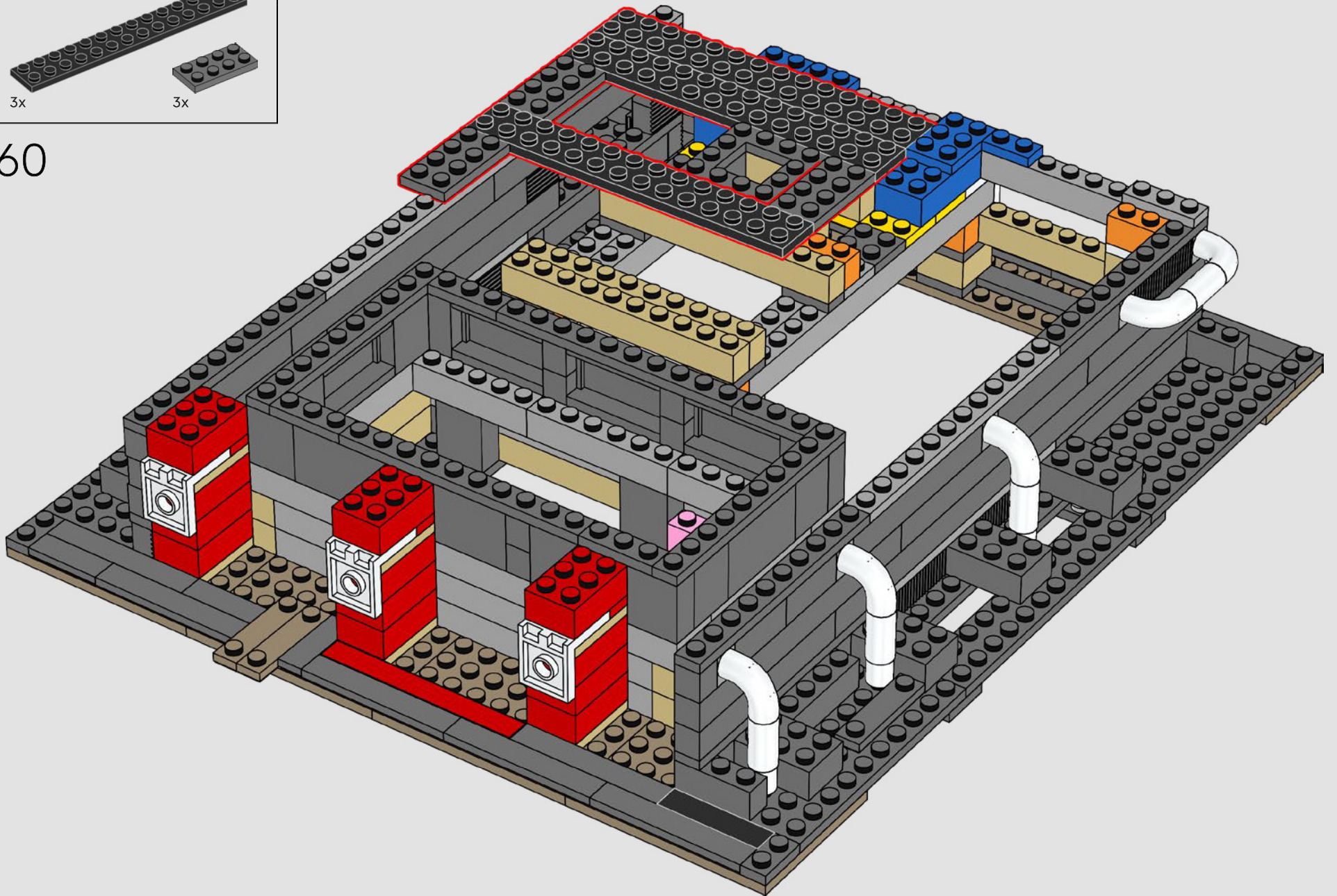



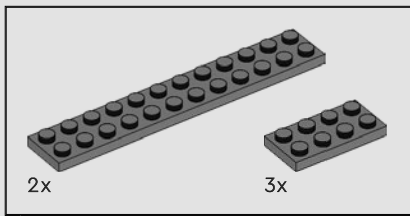

61

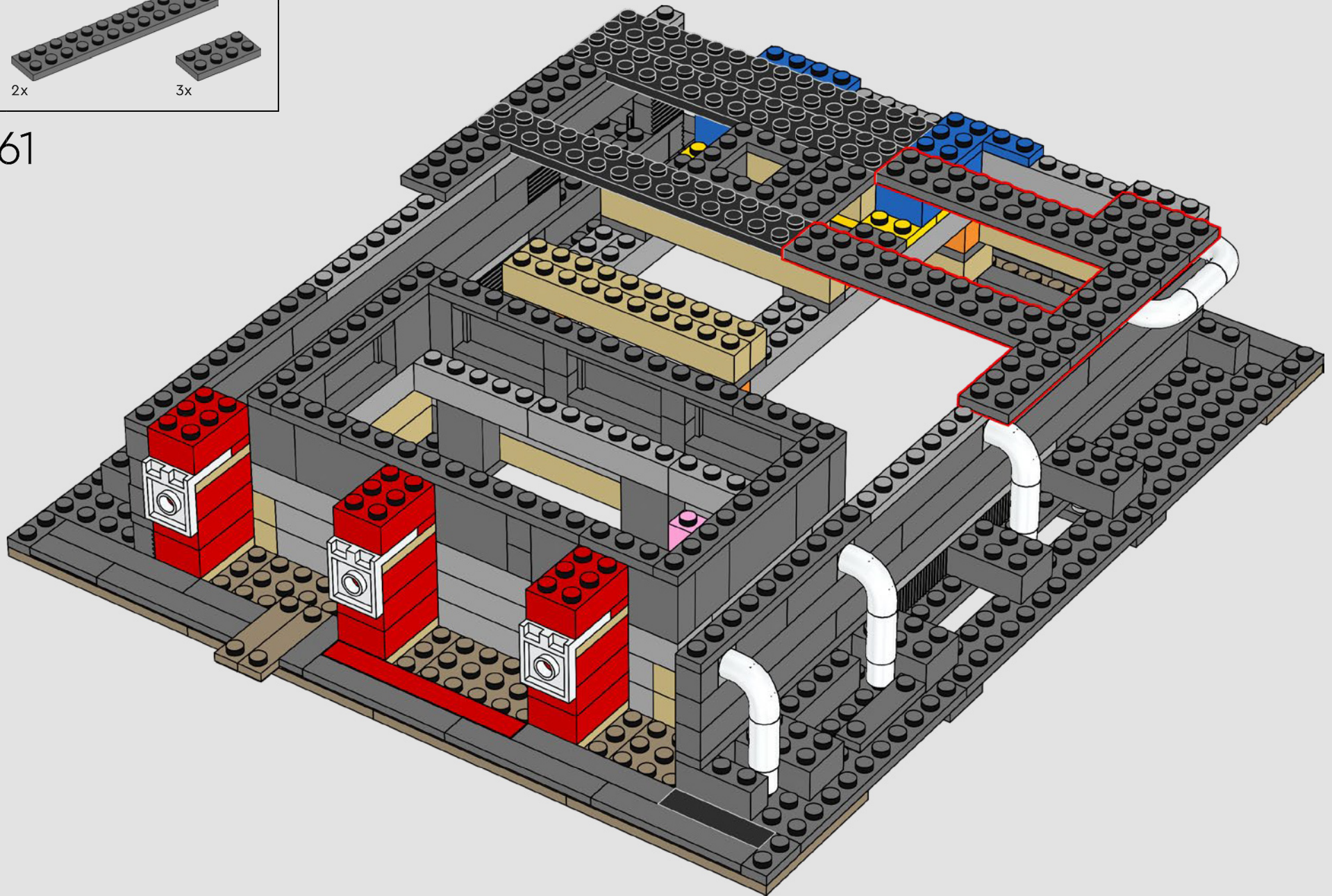

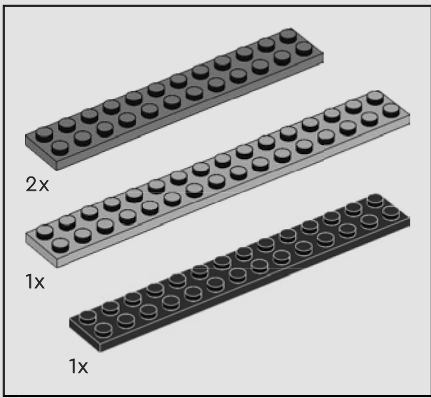

62

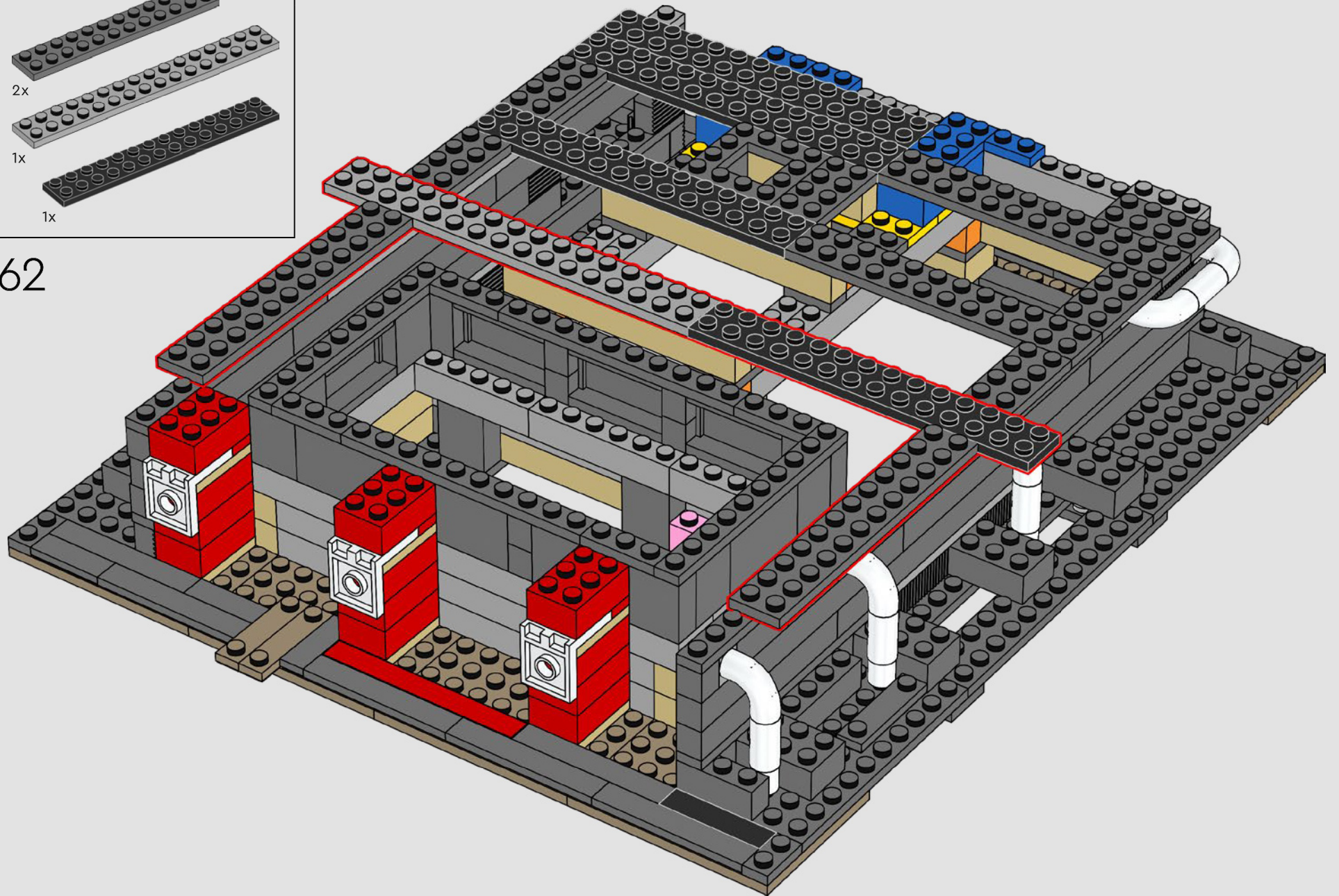

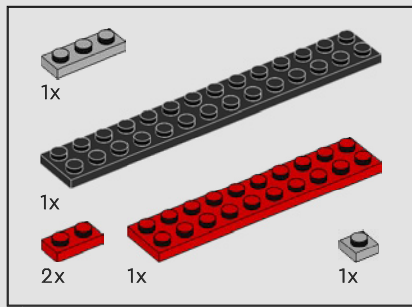

63

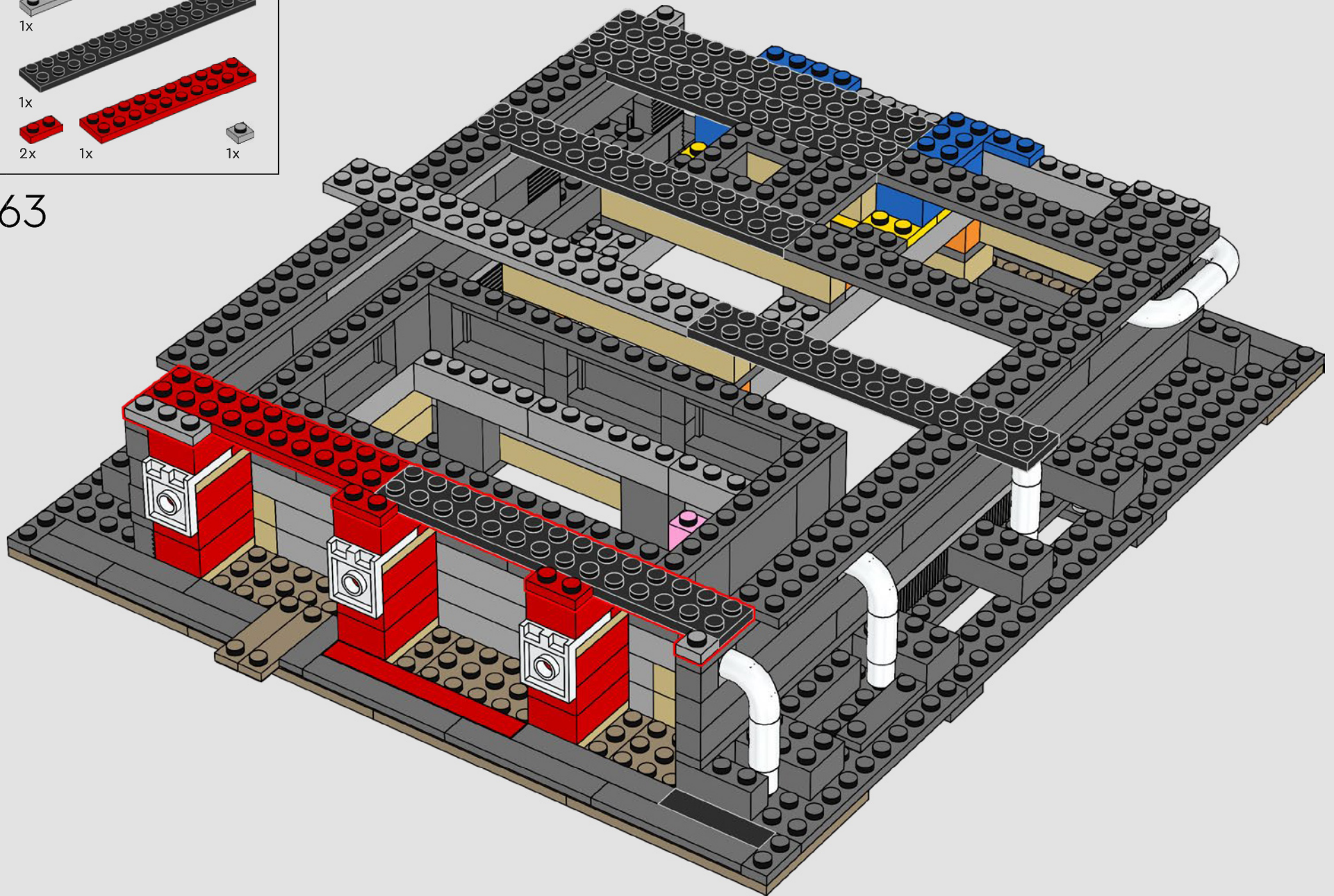

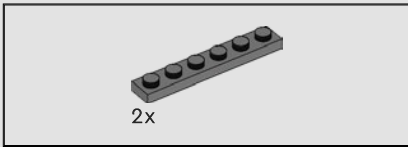
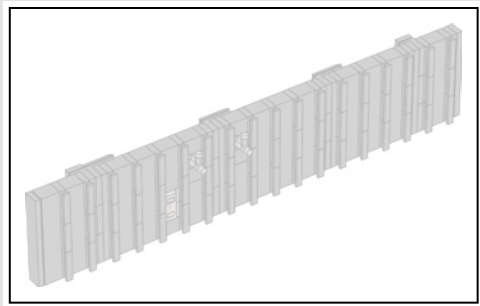

64

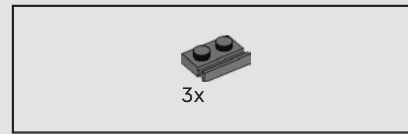
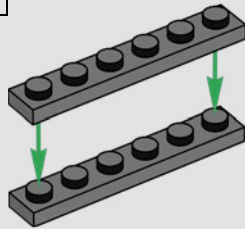

65

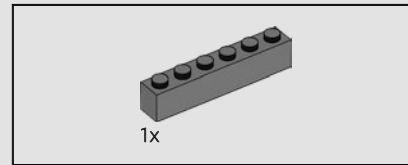
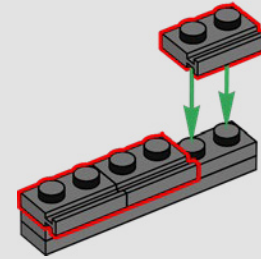

66

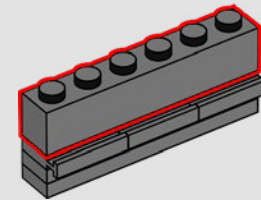

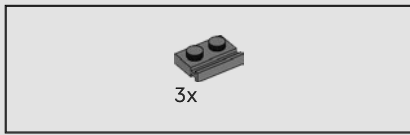

67

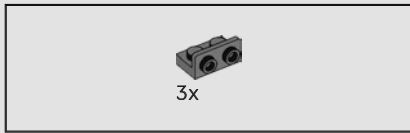
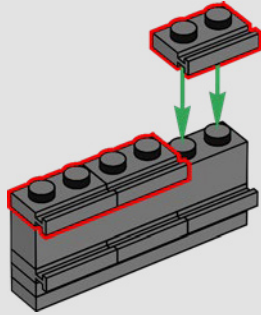

68

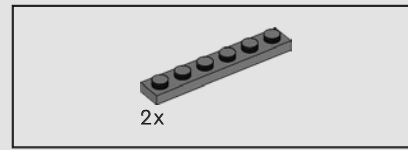
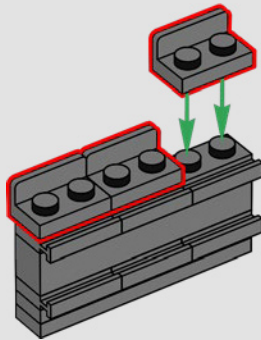

69

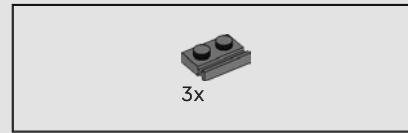
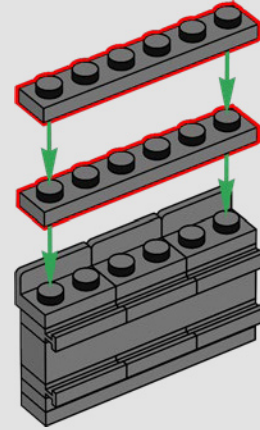

70

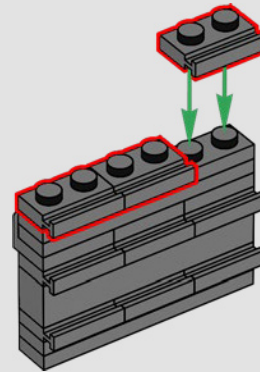

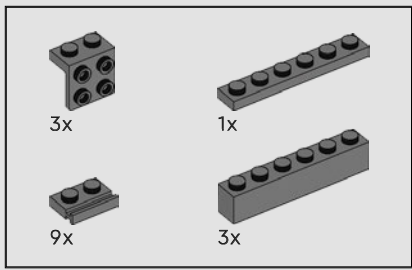

71

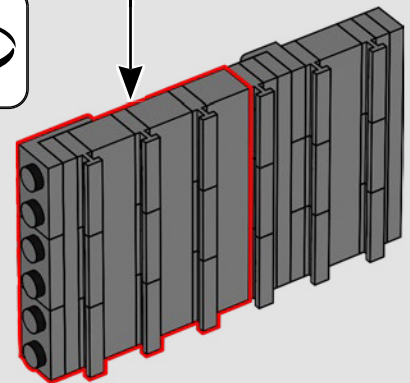
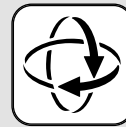
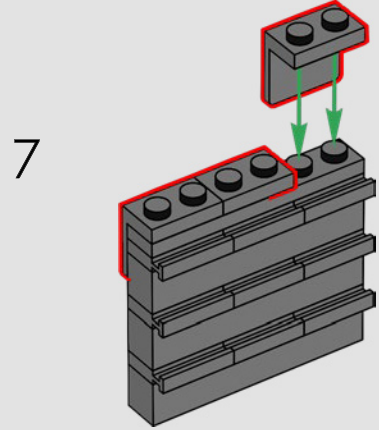
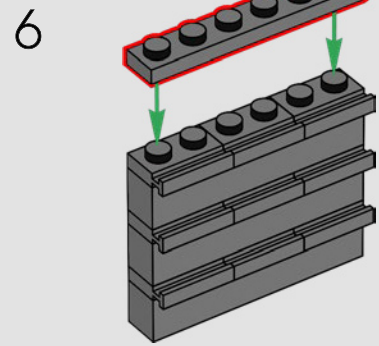
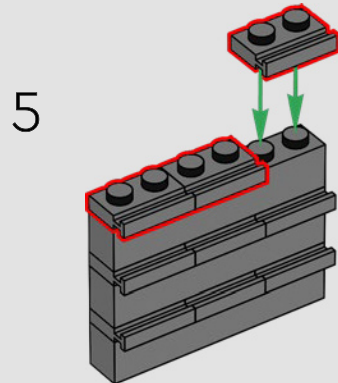
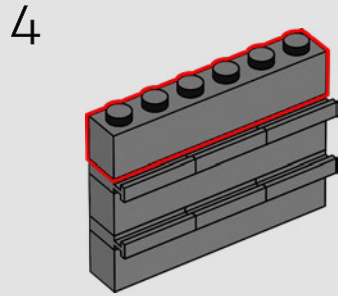
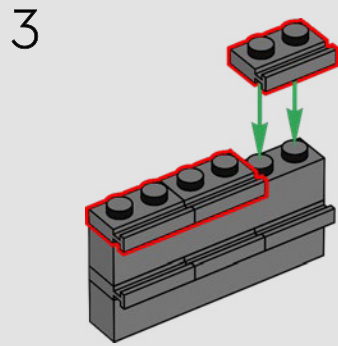
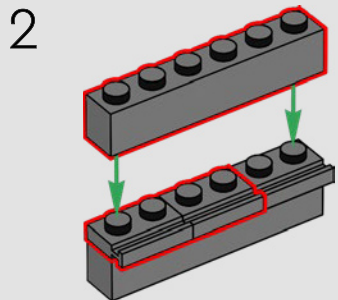
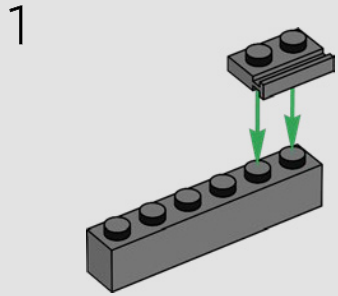

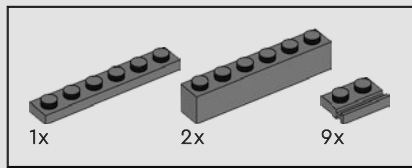

72

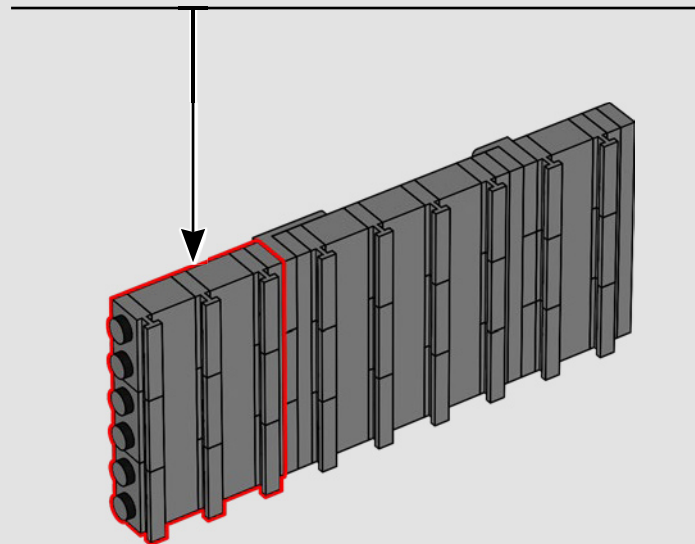
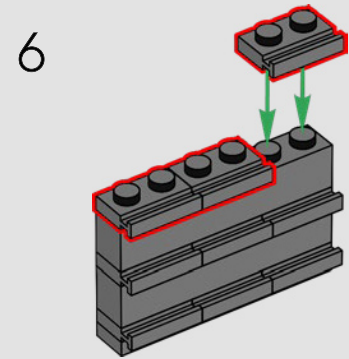
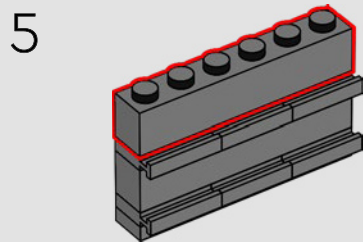
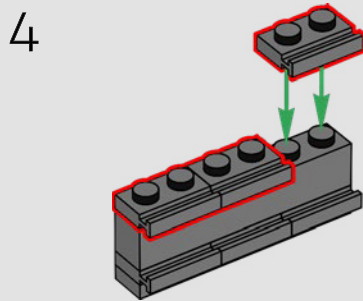
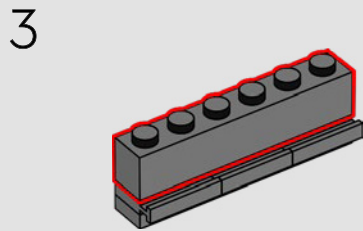
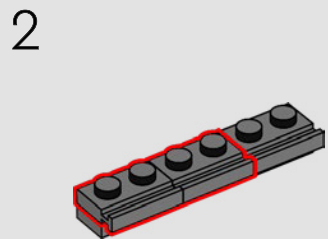
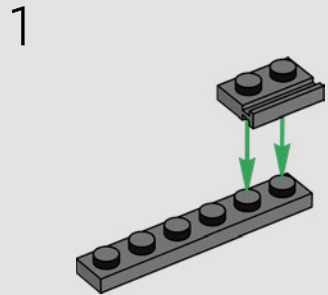

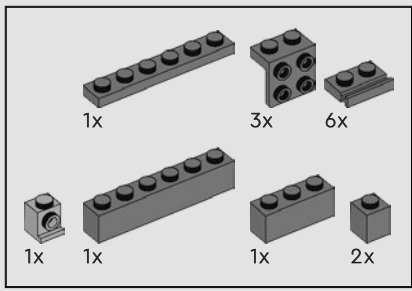

73

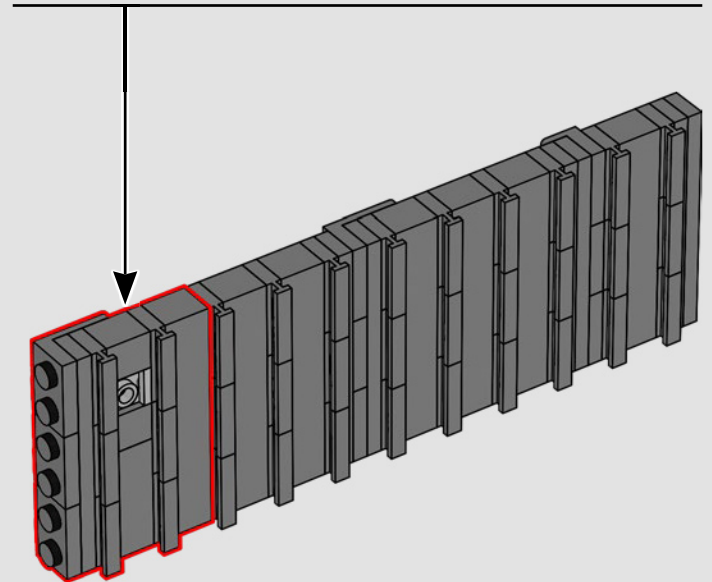
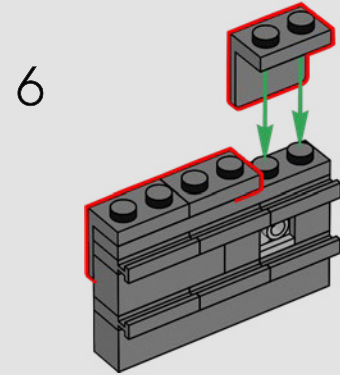
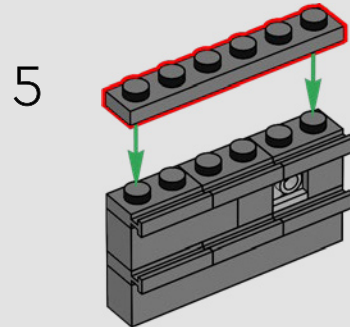
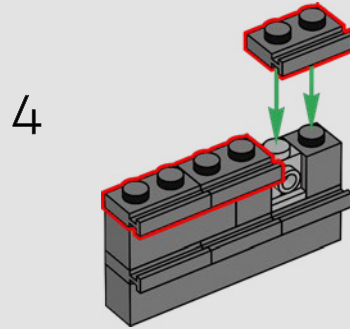
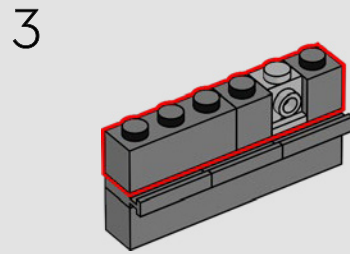
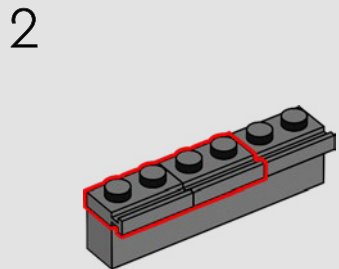
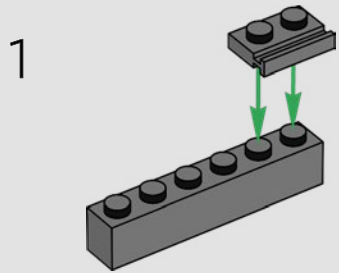



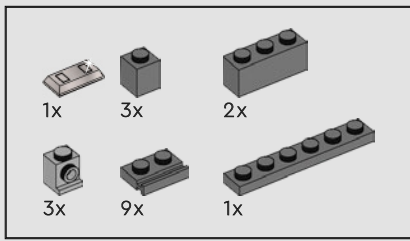

74

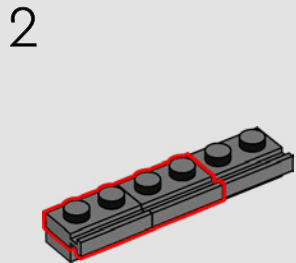
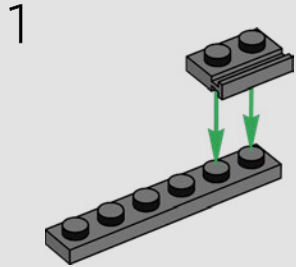

3

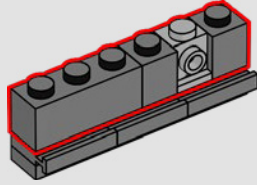

4

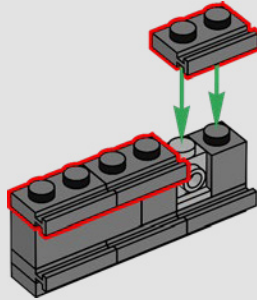

5

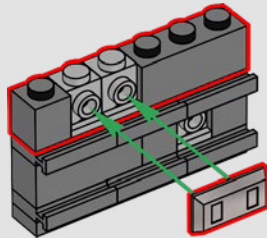

6

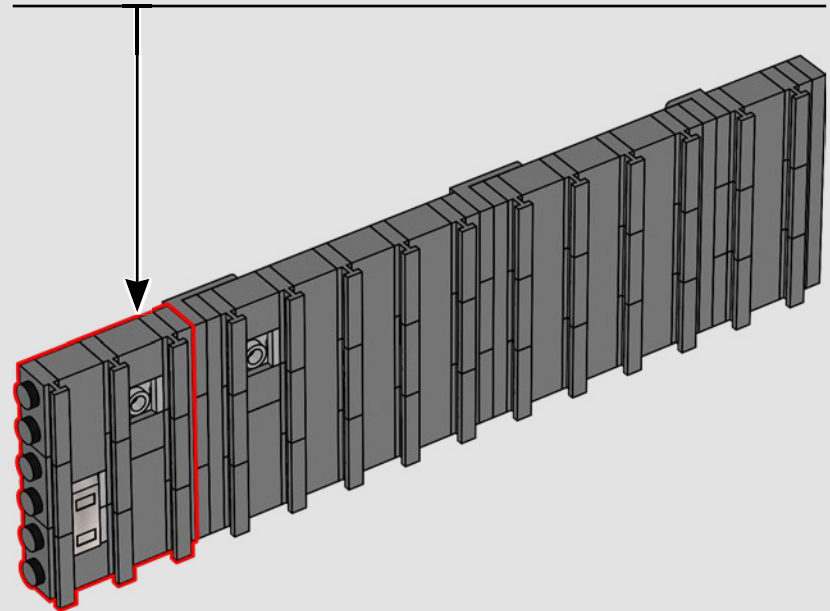
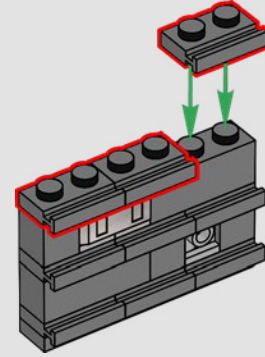

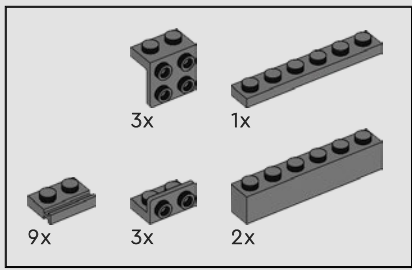

75

1

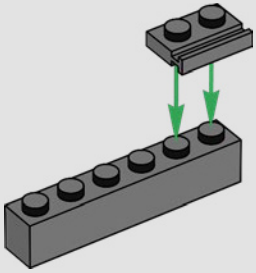

2

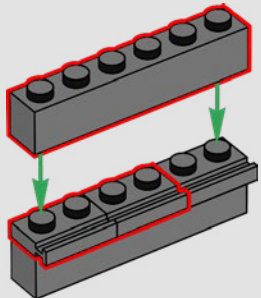

3

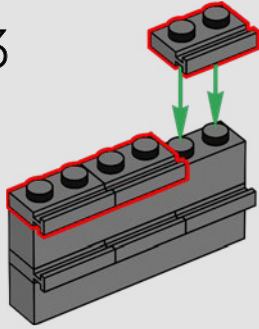

4

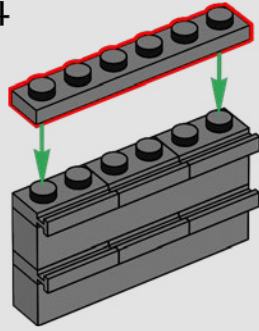

5

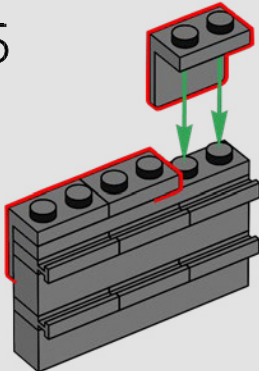

6

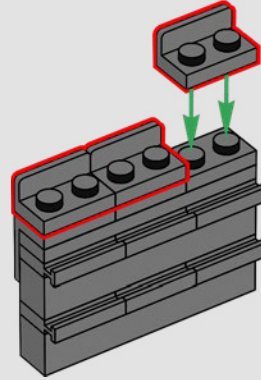

7

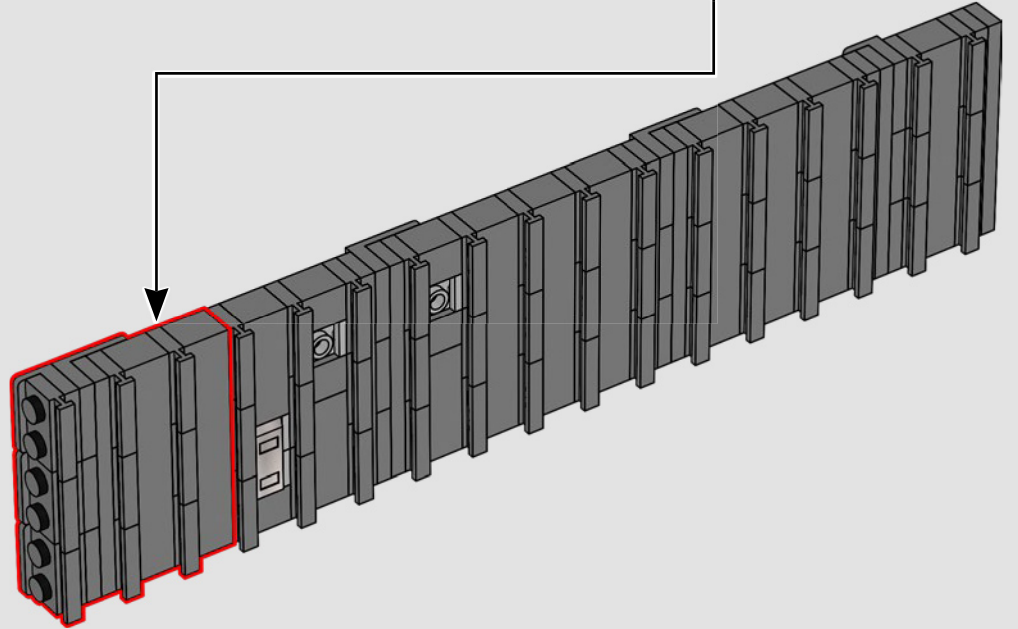
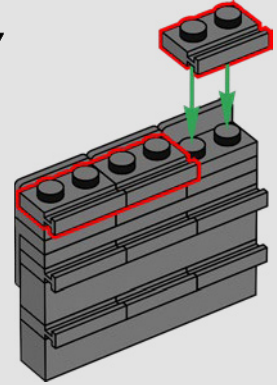

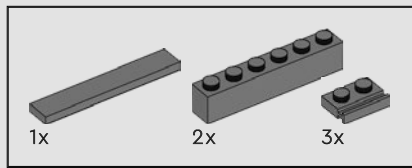

76

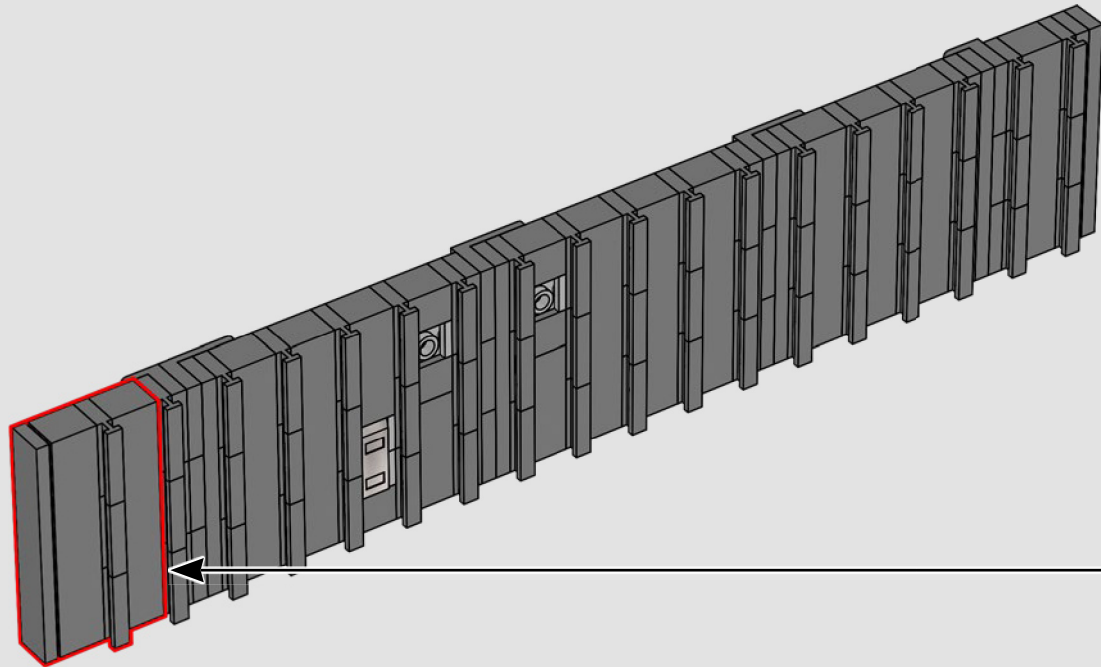
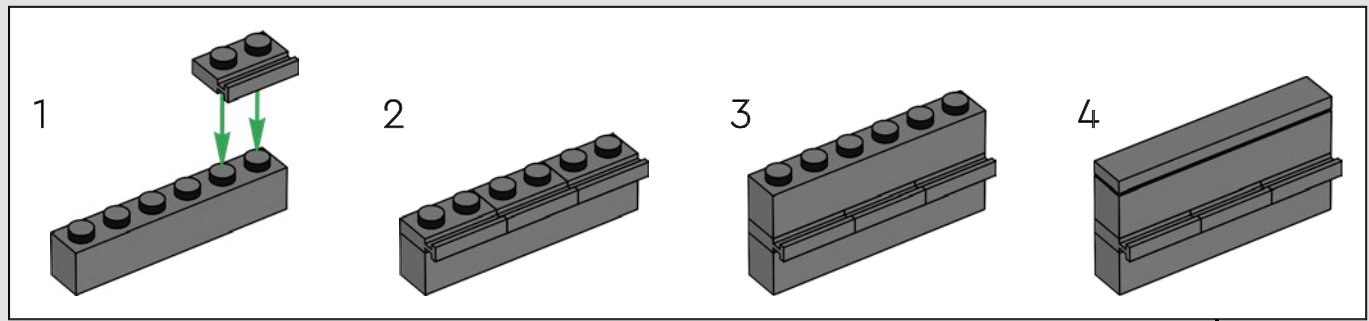

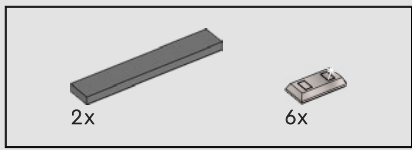

77

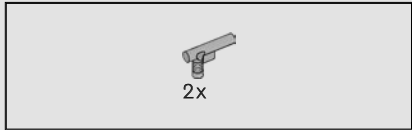
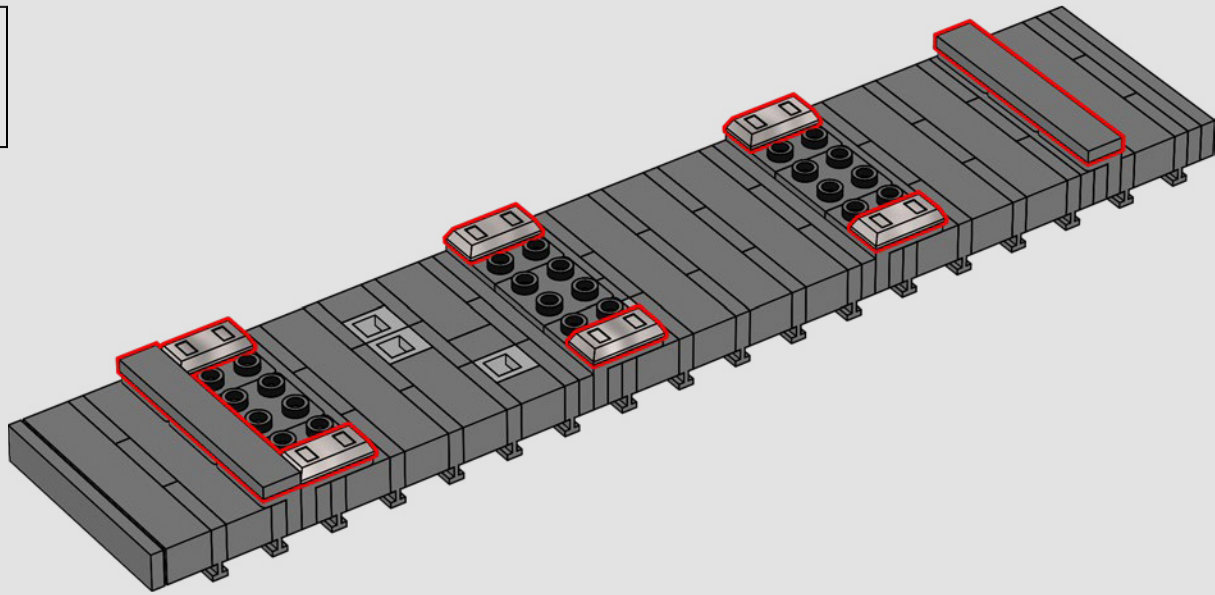

78

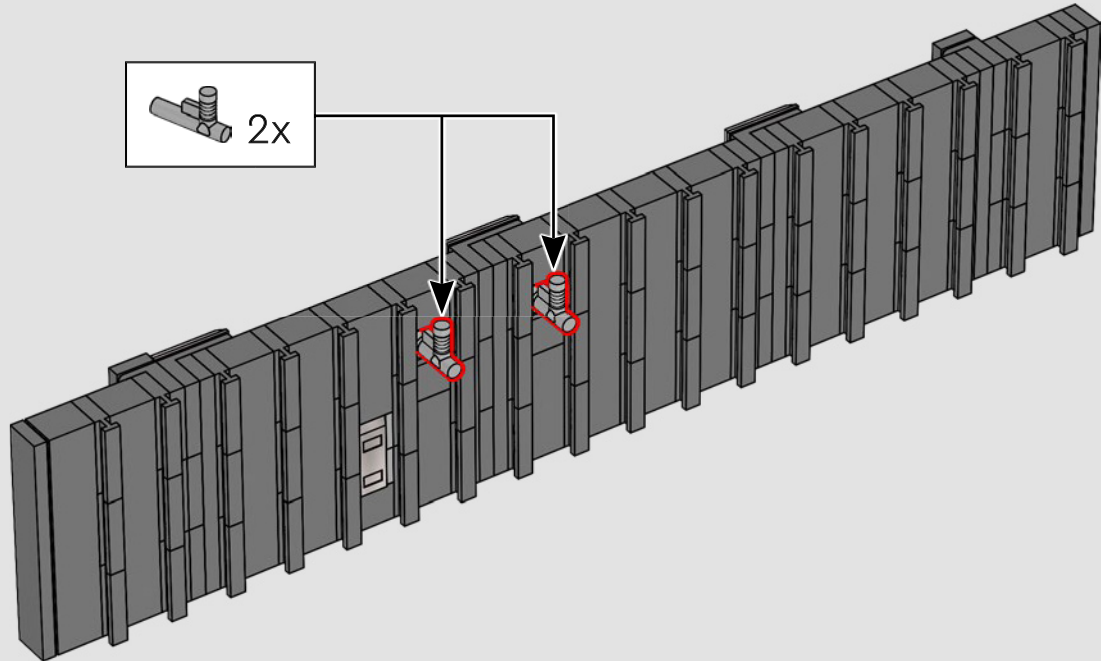
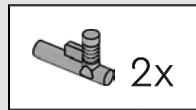

79

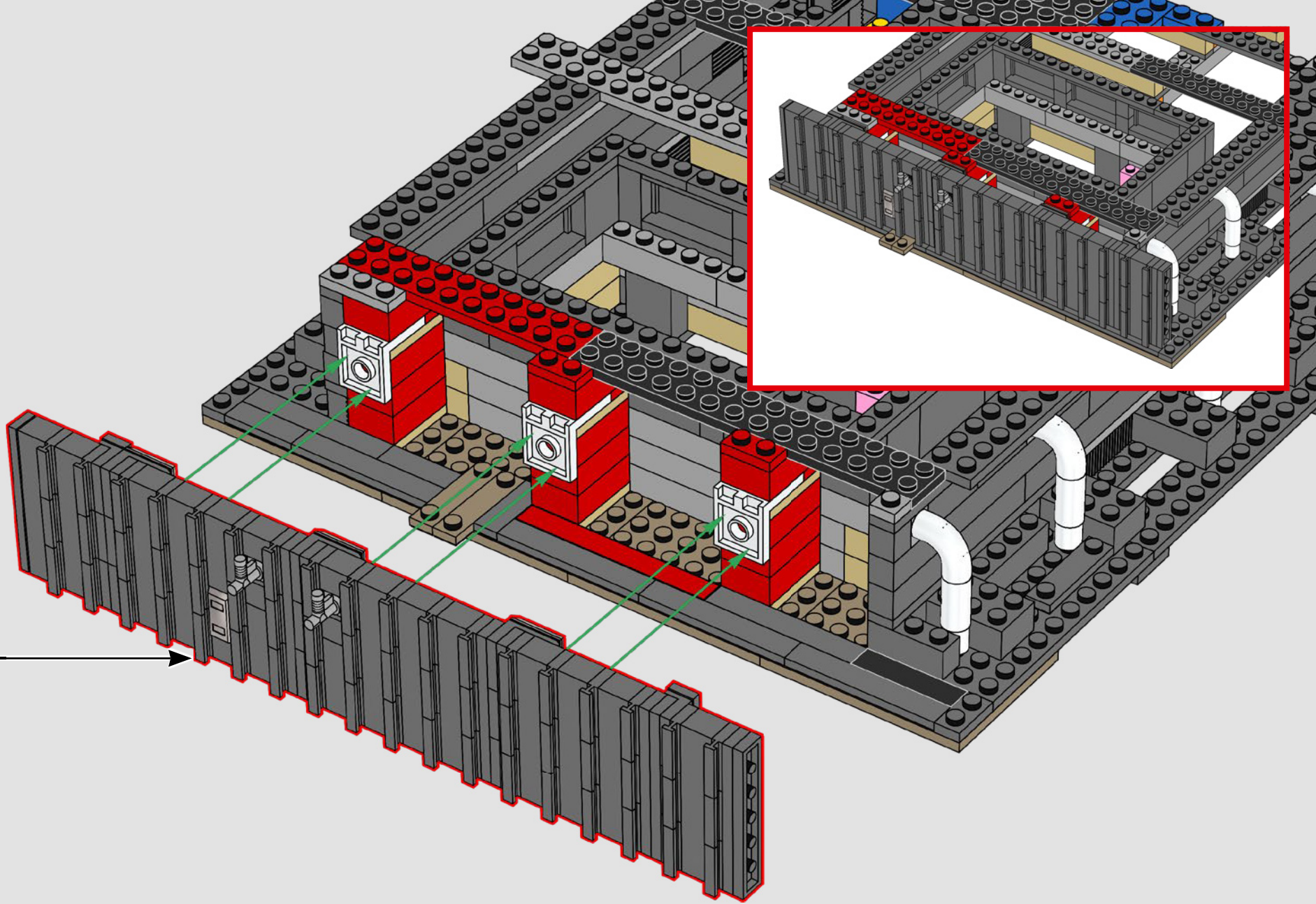

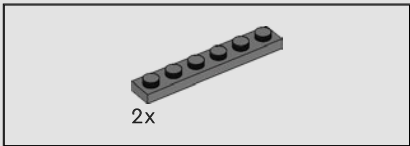
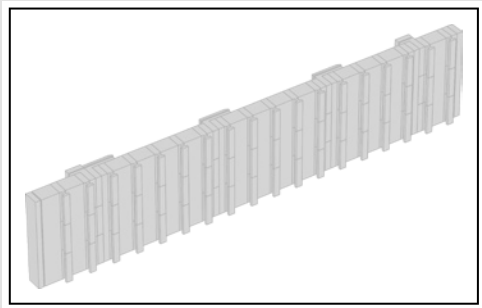

80

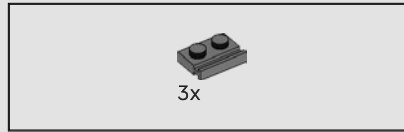
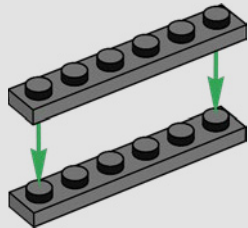

81

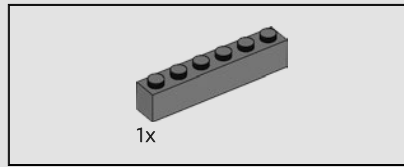
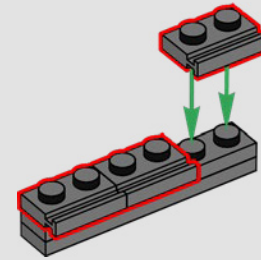

82

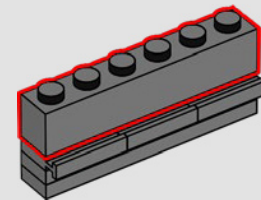

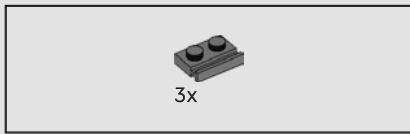

83

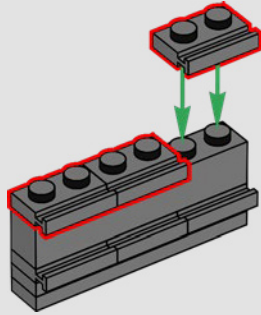

84

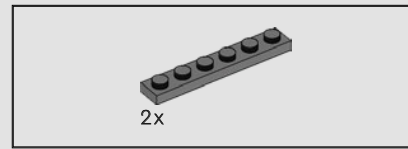
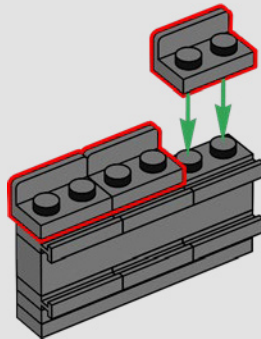

85

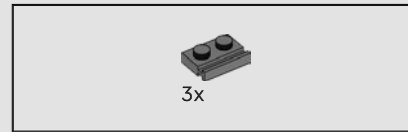
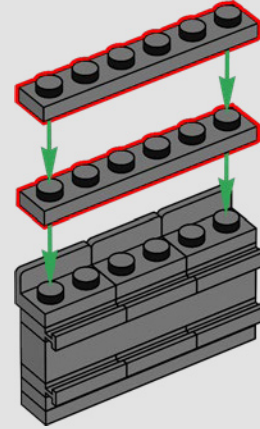

86

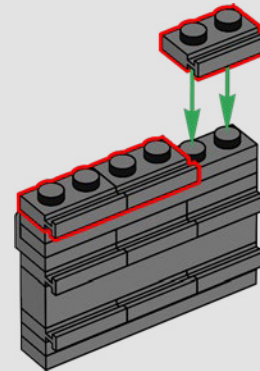

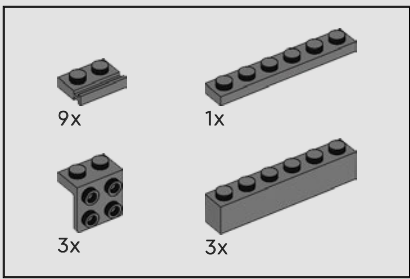

87

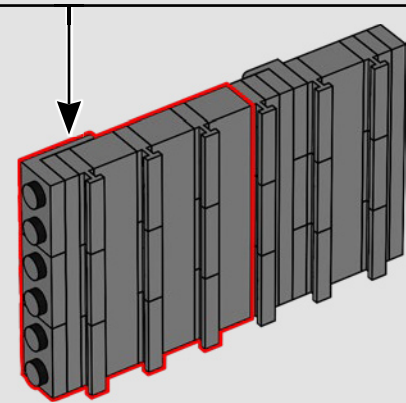
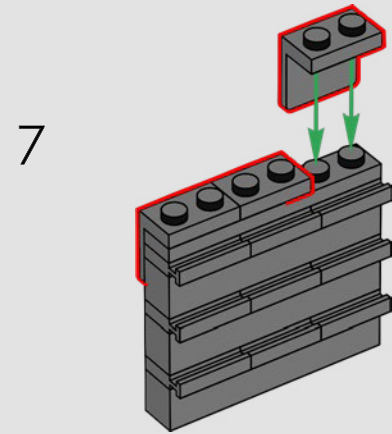
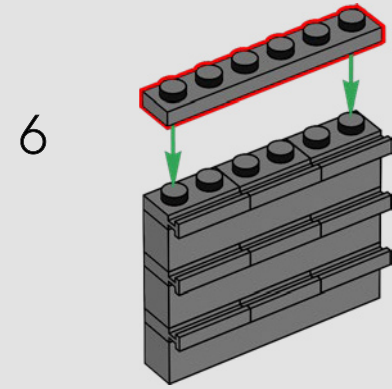
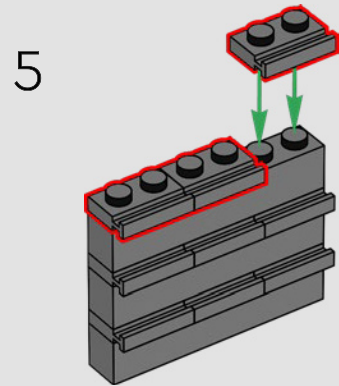
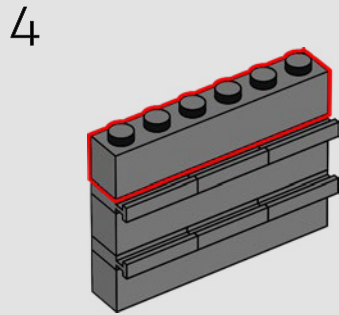
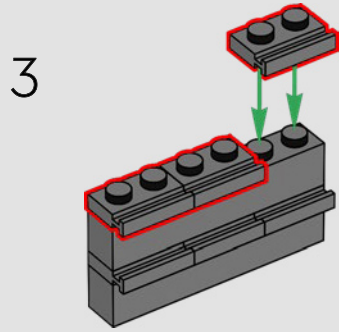
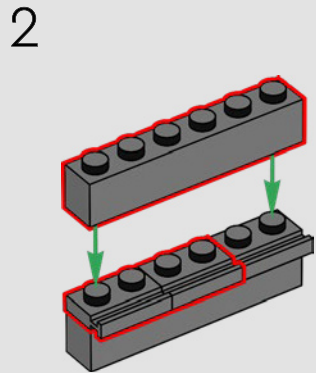
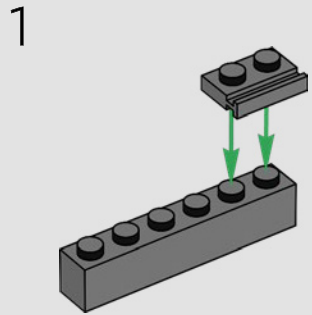



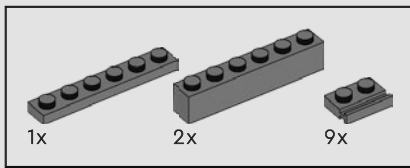

88

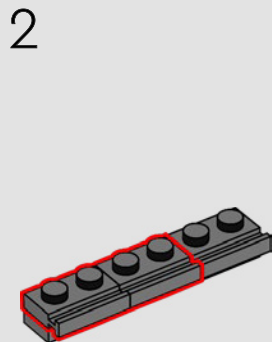
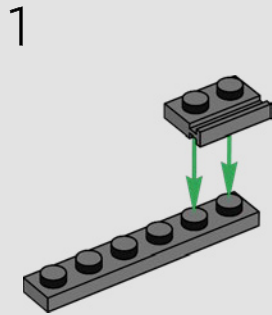

3

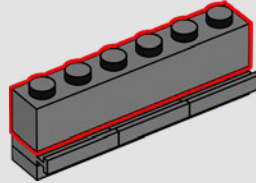

4

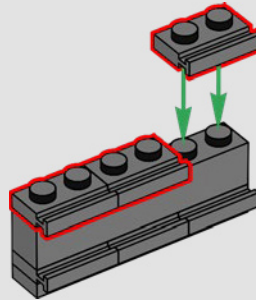

5

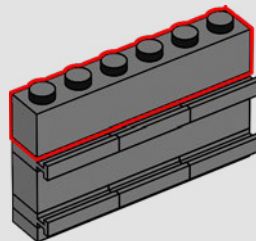

6

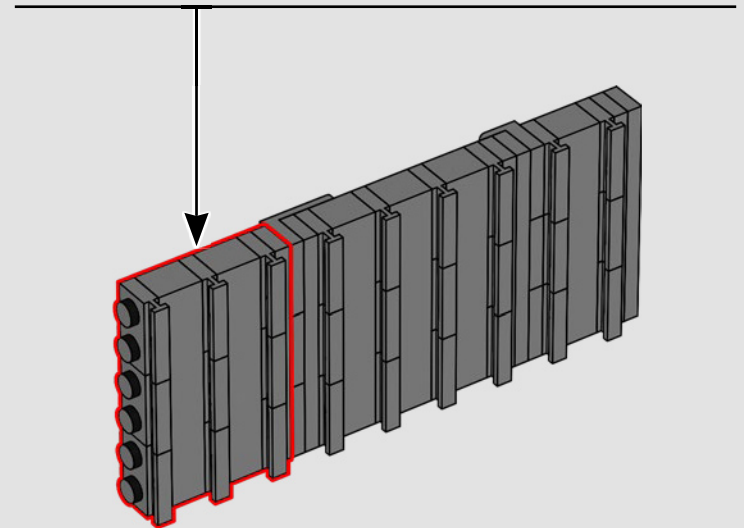
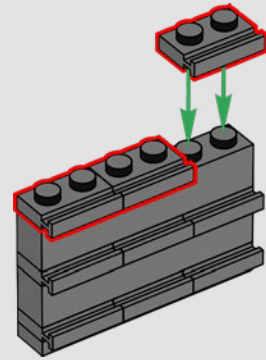

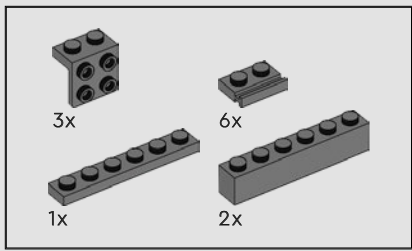

89

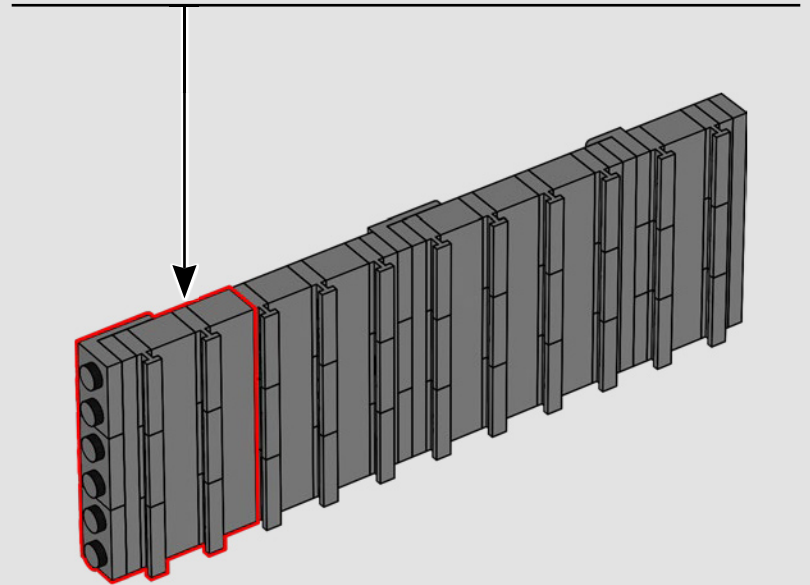
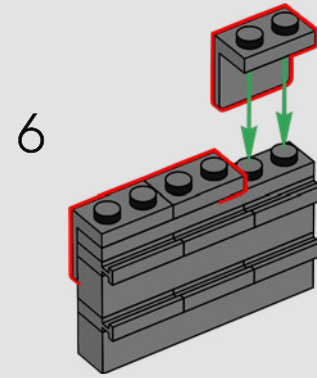
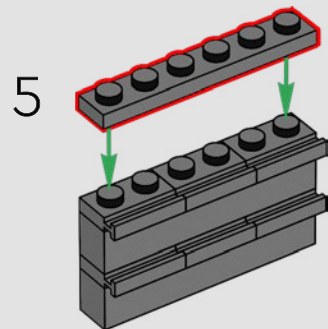
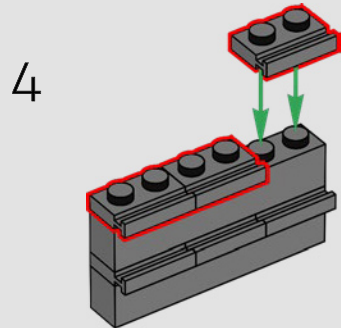
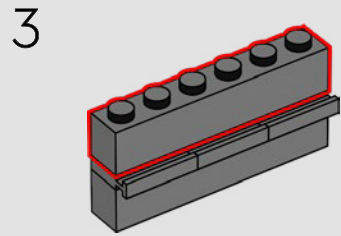
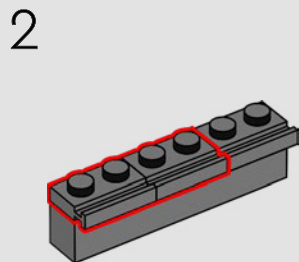
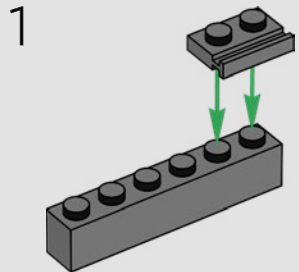

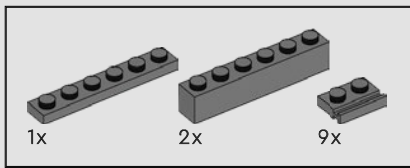

90

1

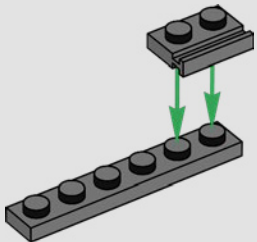

2

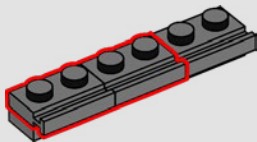

3

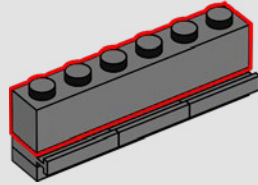

4

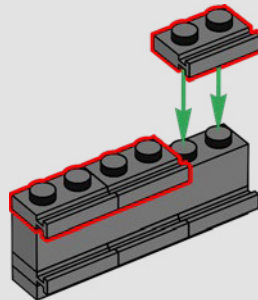

5

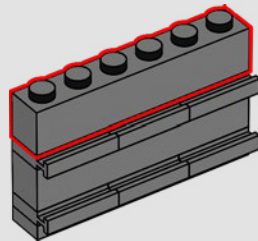

6

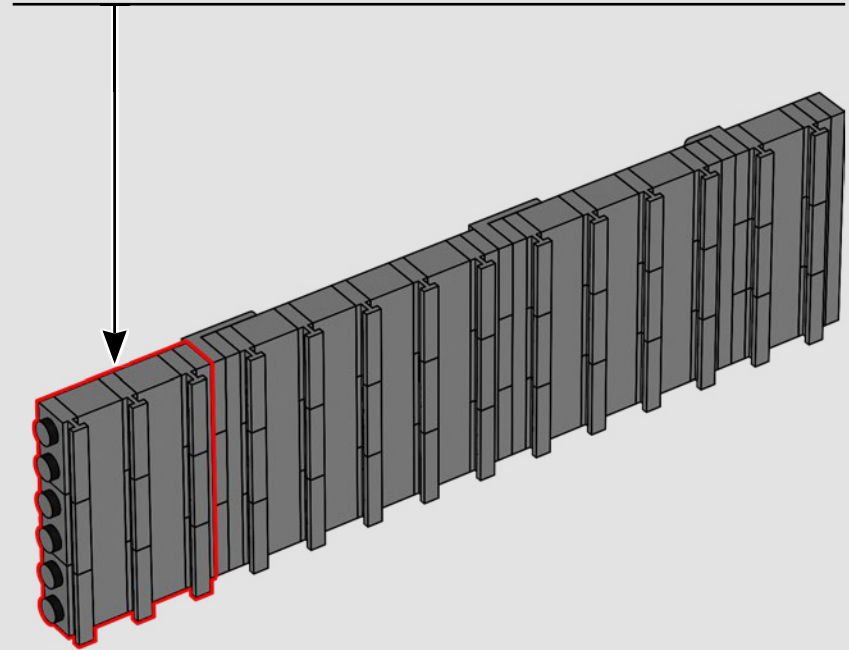
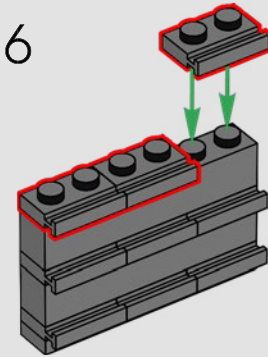

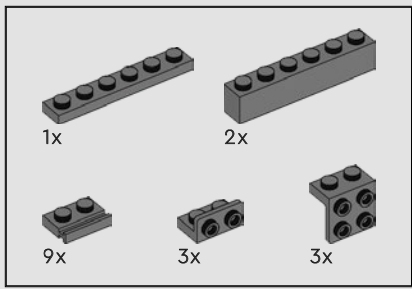

91

1

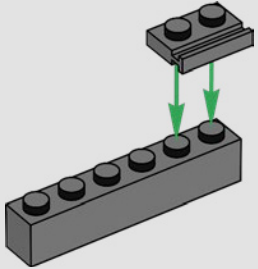

2

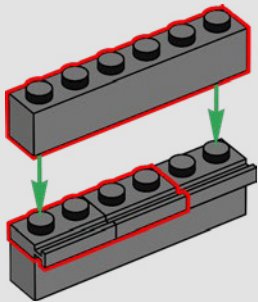

3

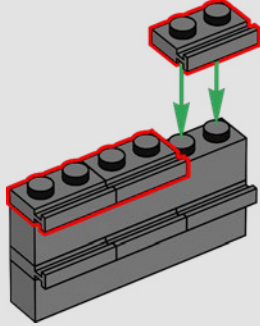

4

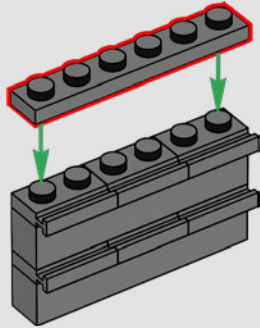

5

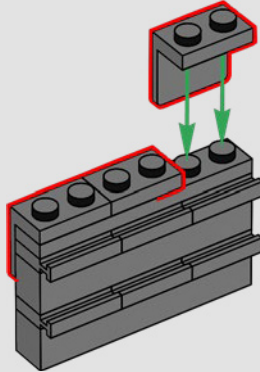

6

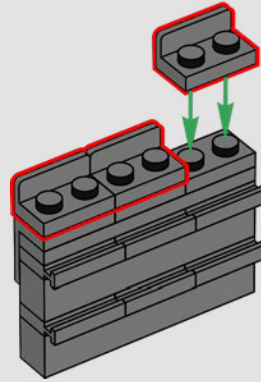

7

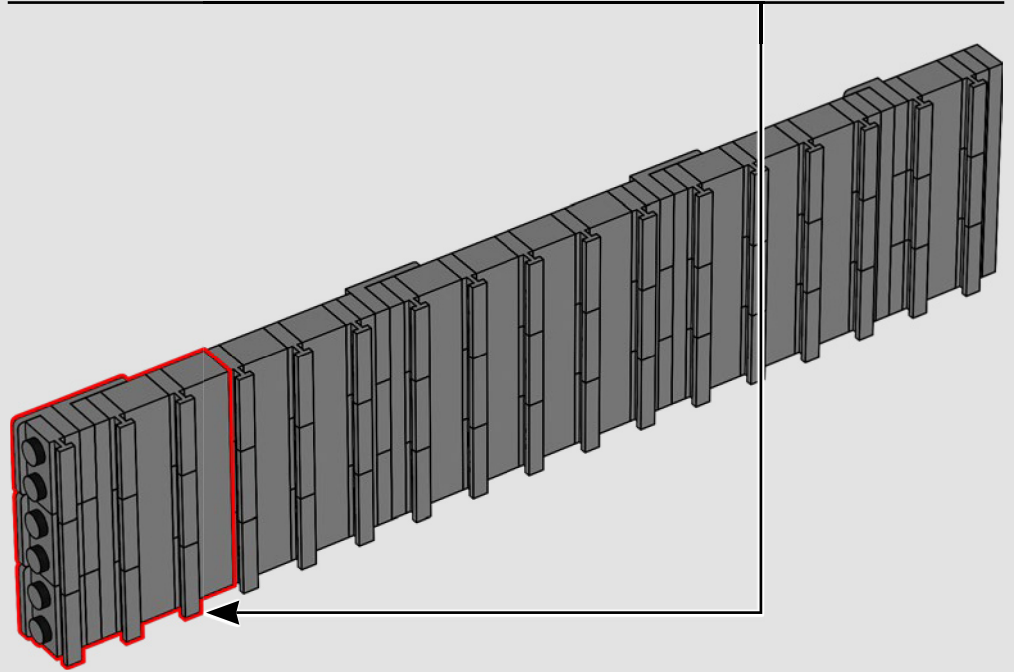
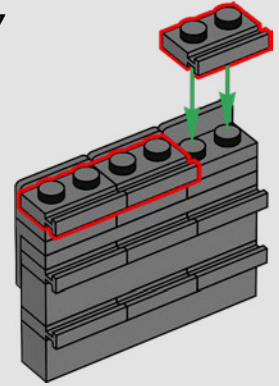

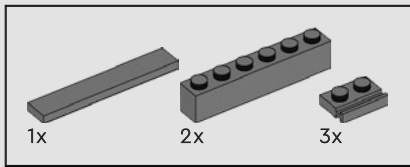

92

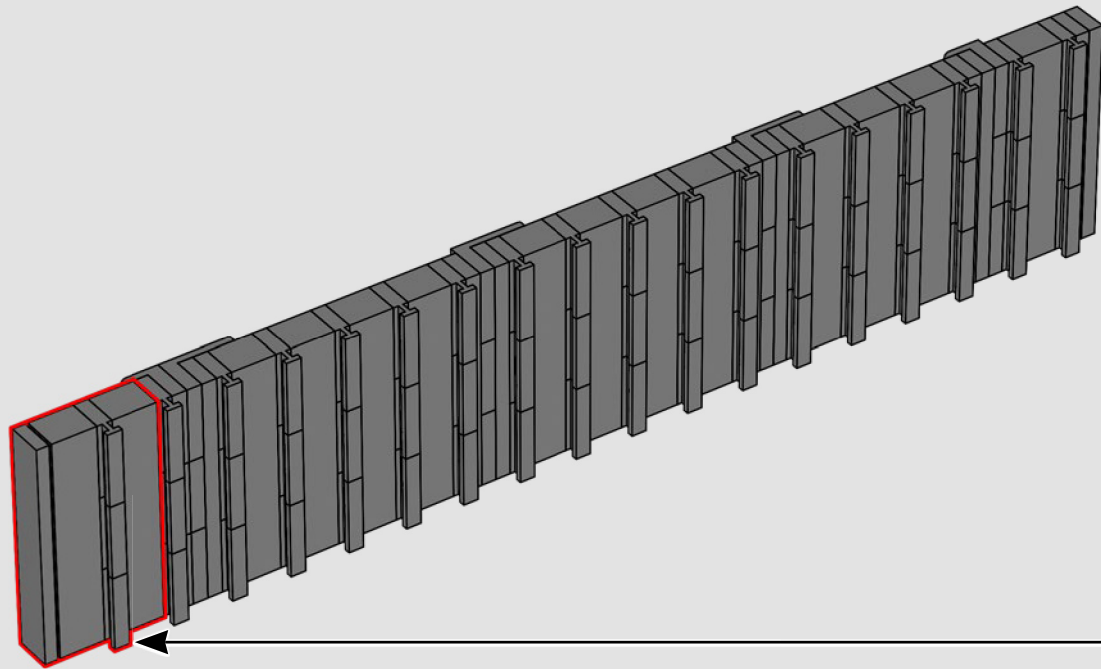
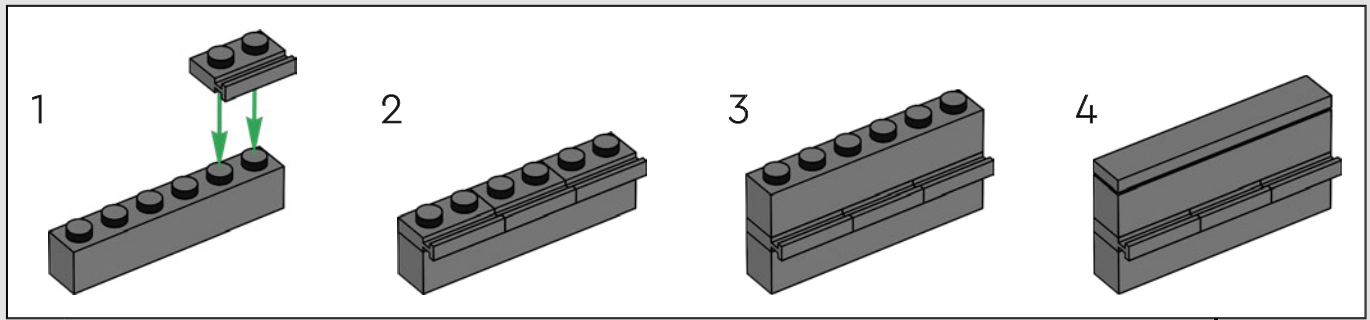

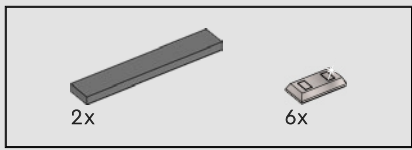

93

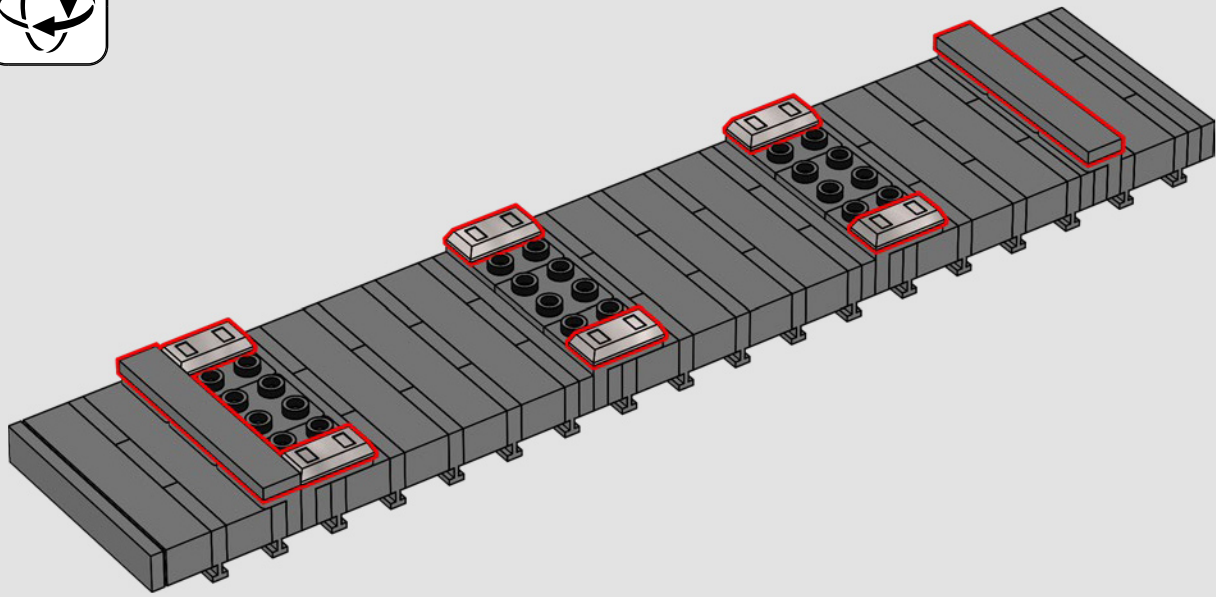

94

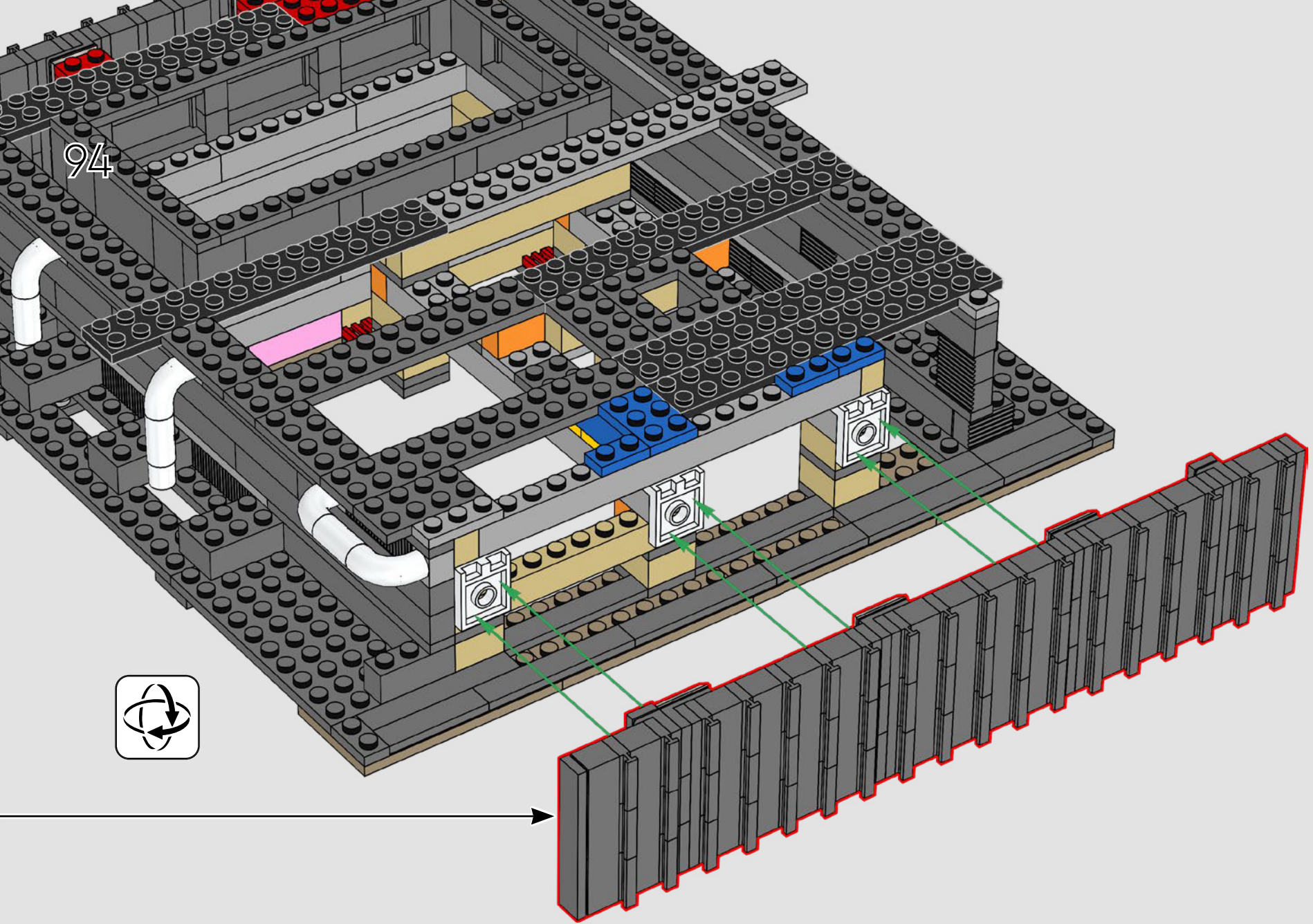

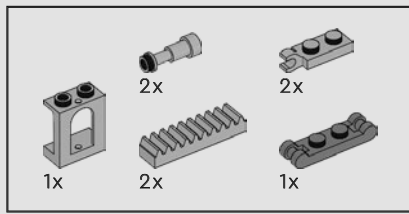

95

1

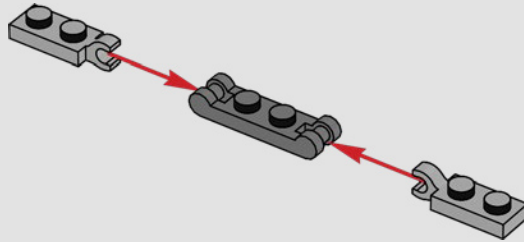

2

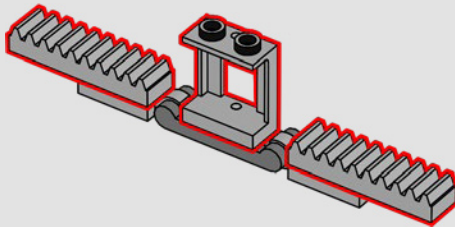

3

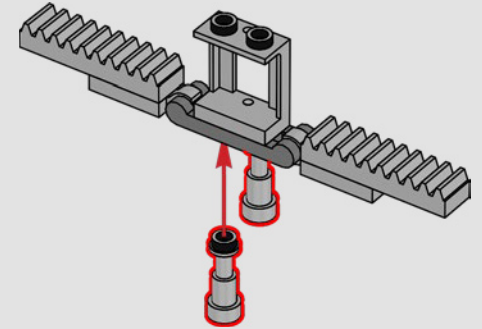

4

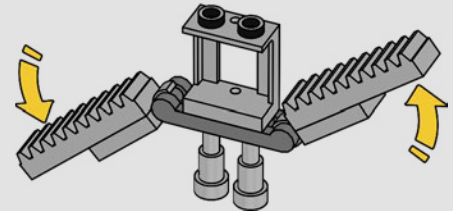



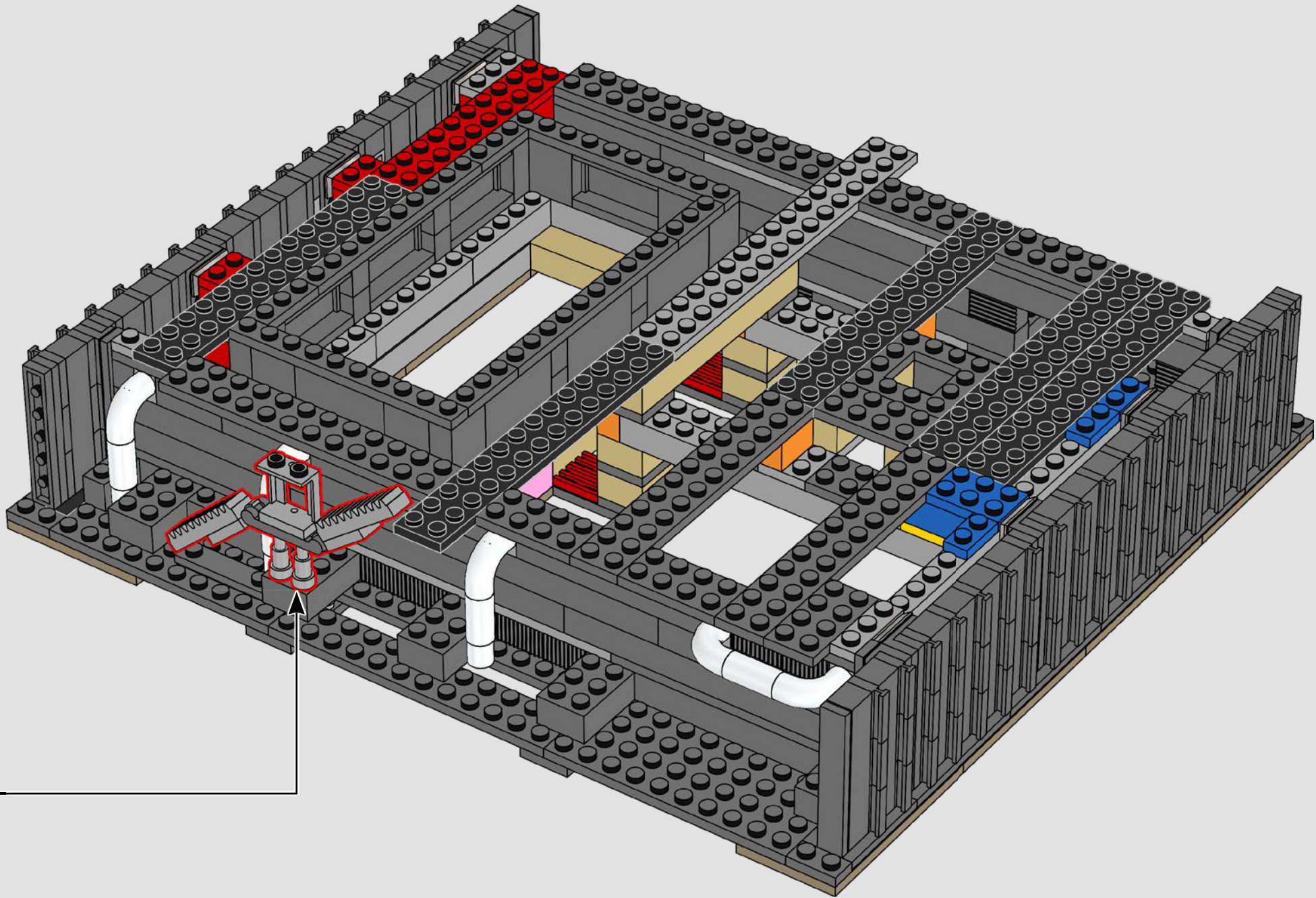

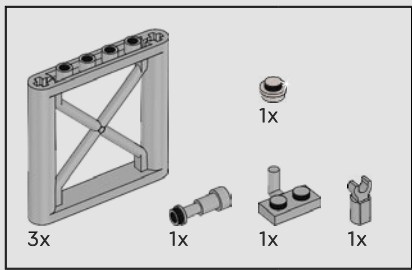

96

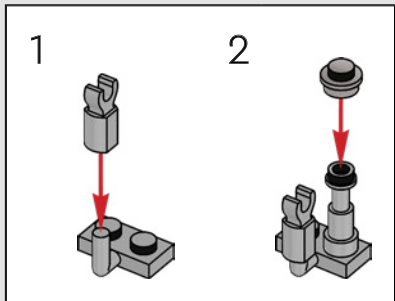
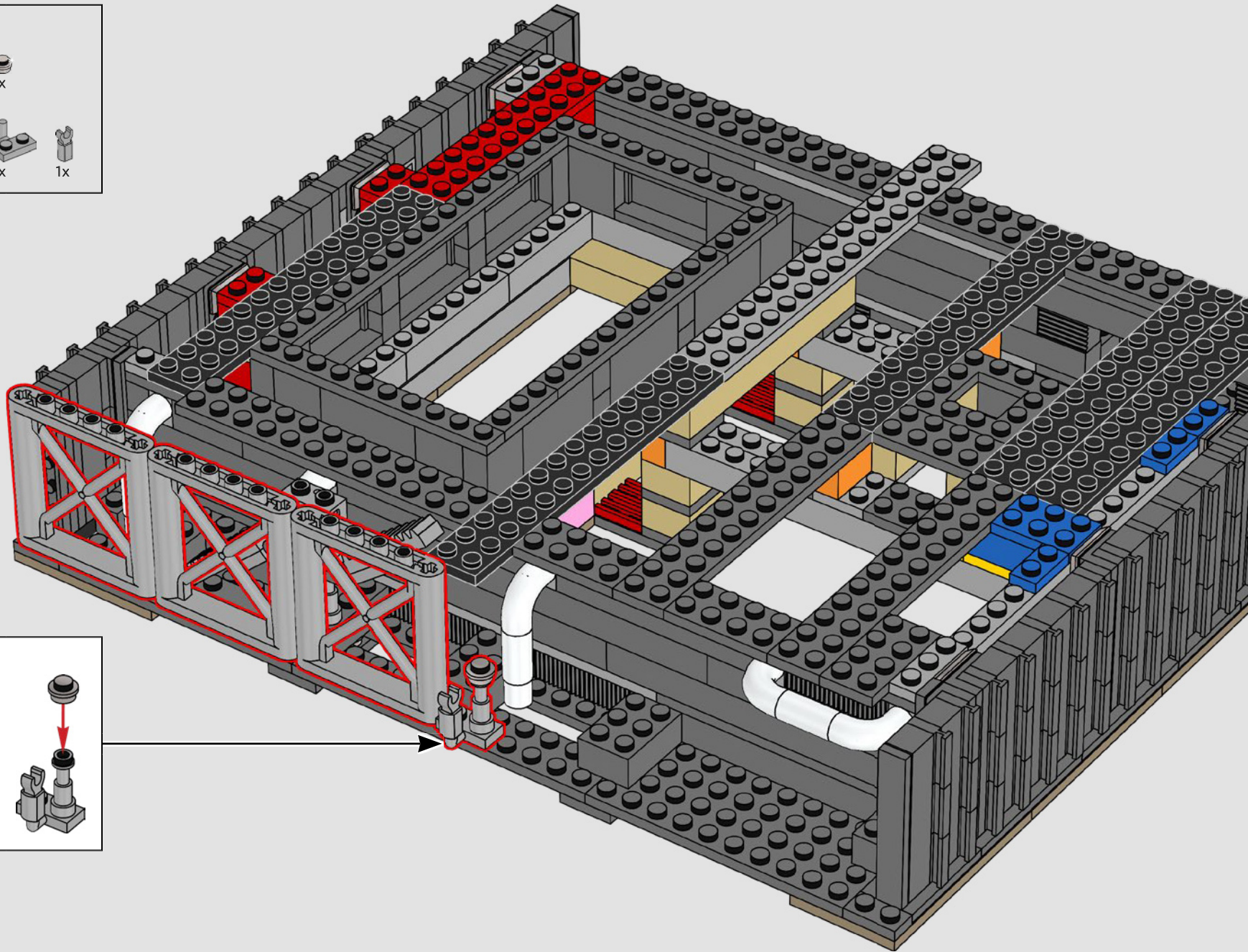

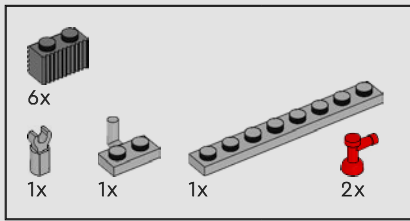

97

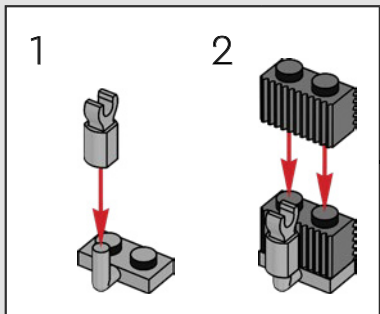
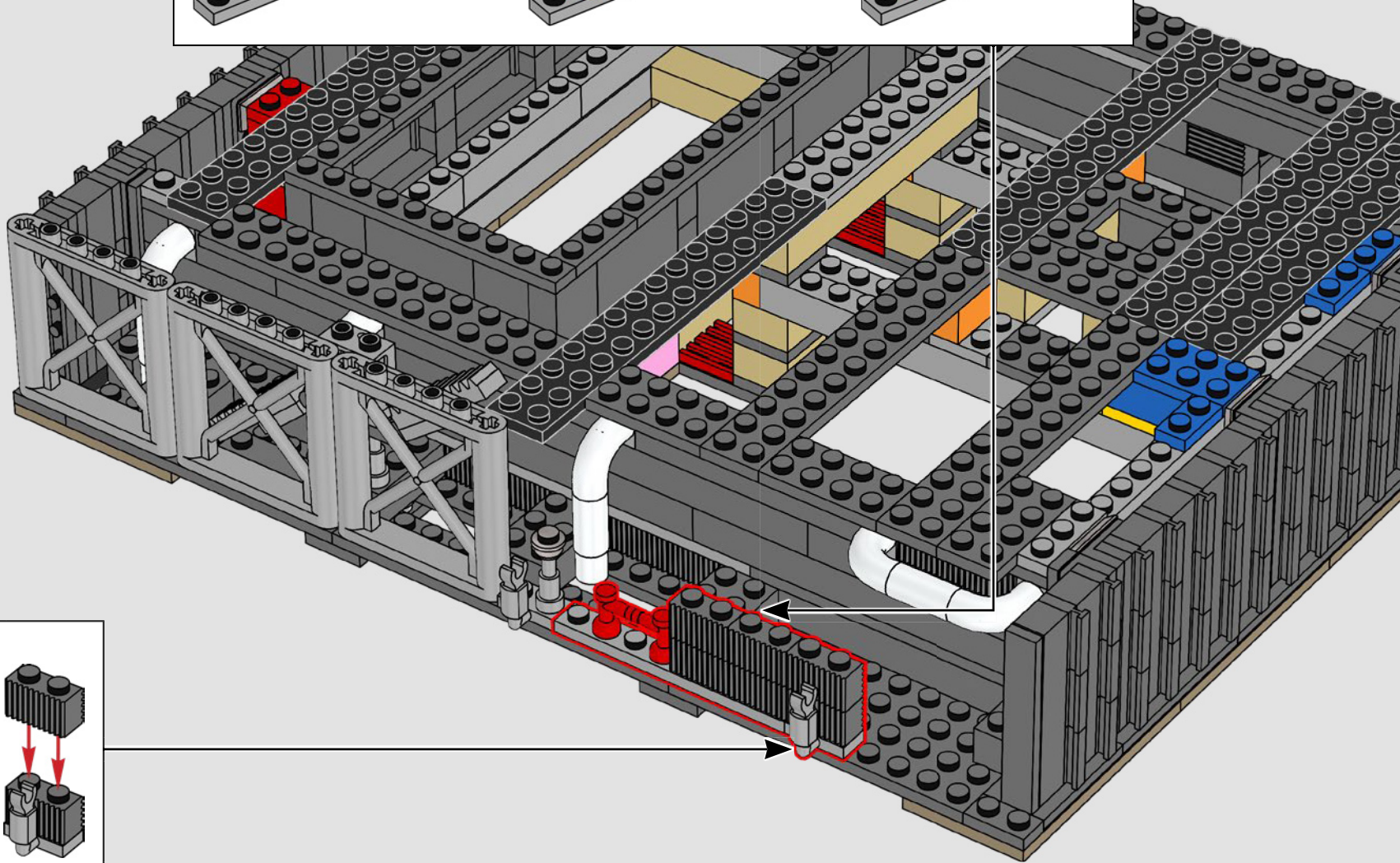
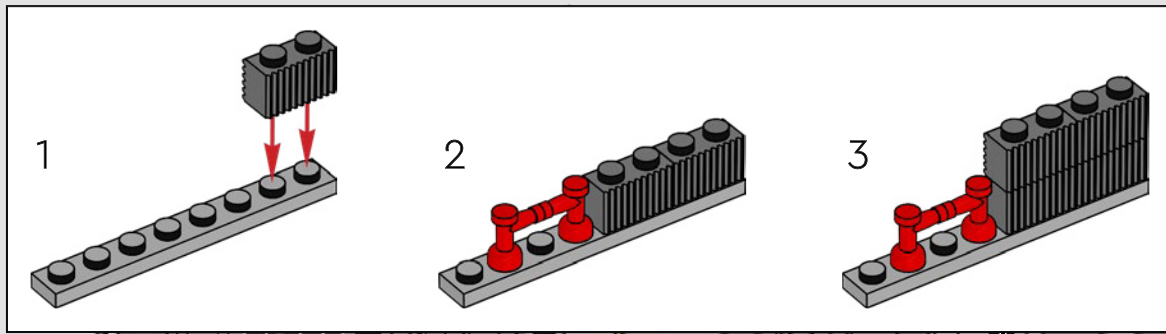

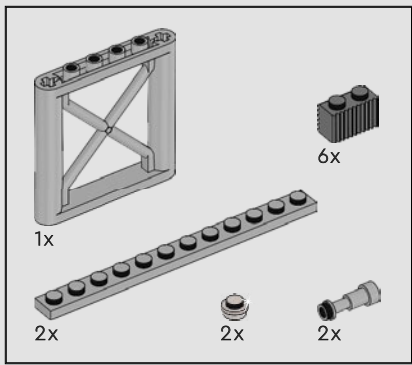

98

1

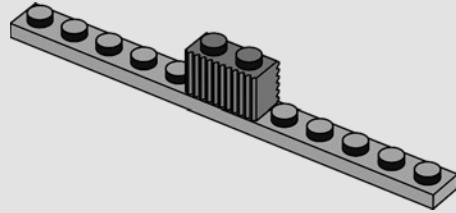

2

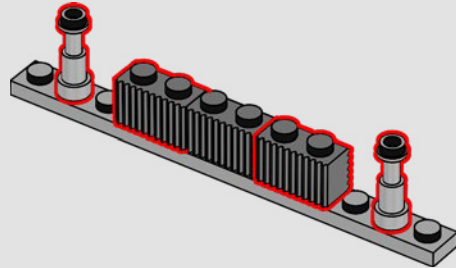

3

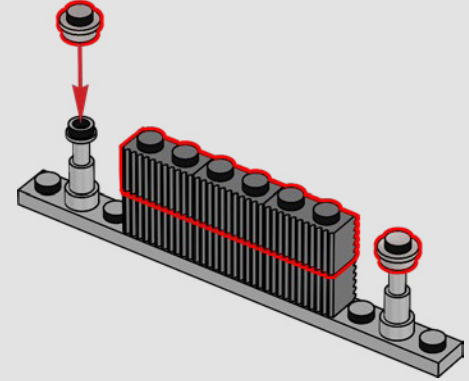

4

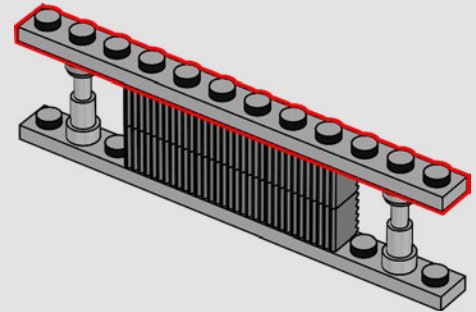

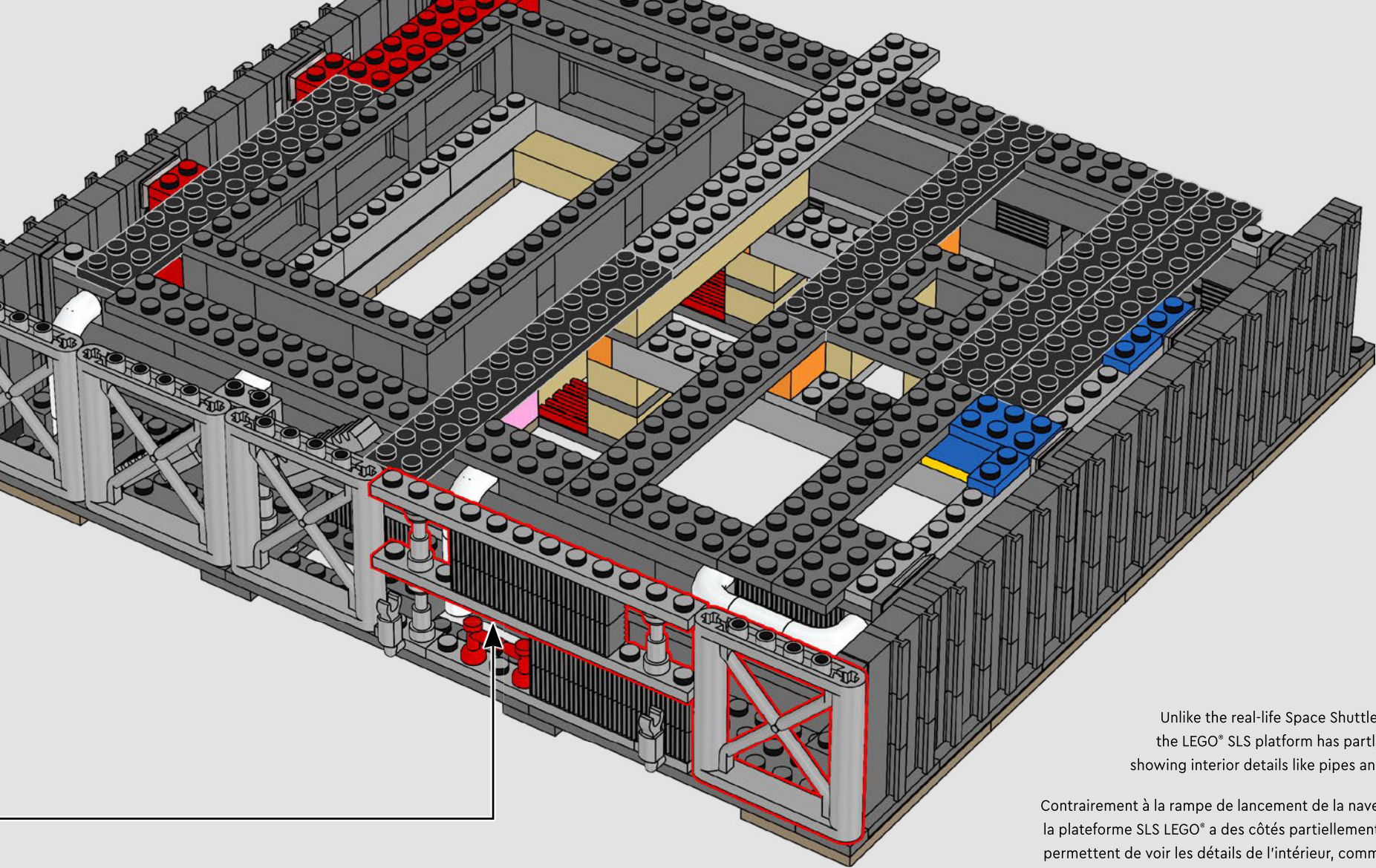

Unlike the real-life Space Shuttle launch pad, the LEGO® SLS platform has partly open sides showing interior details like pipes and staircases.

Contrairement à la rampe de lancement de la navette spatiale, la plateforme SLS LEGO® a des côtés partiellement ouverts qui permettent de voir les détails de l'intérieur, comme les tuyaux et les escaliers.

A diferencia de la plataforma de lanzamiento de los transbordadores espaciales de la vida real, la plataforma del SLS LEGO® tiene aberturas parciales a los lados para que puedan verse los detalles de su interior, como tuberías y escaleras.

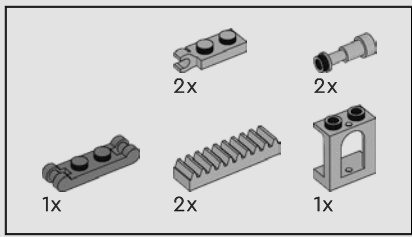

99

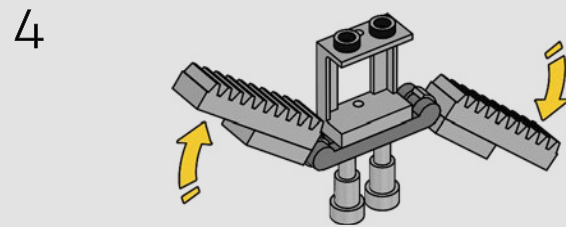
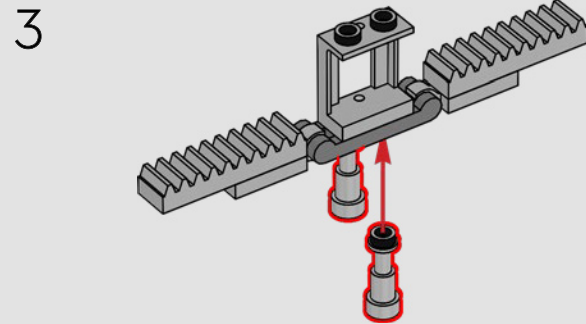
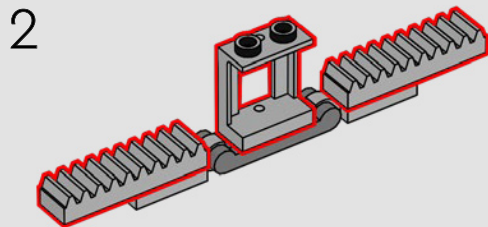
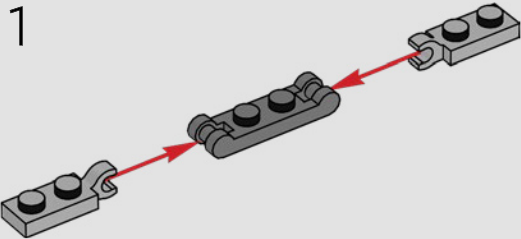

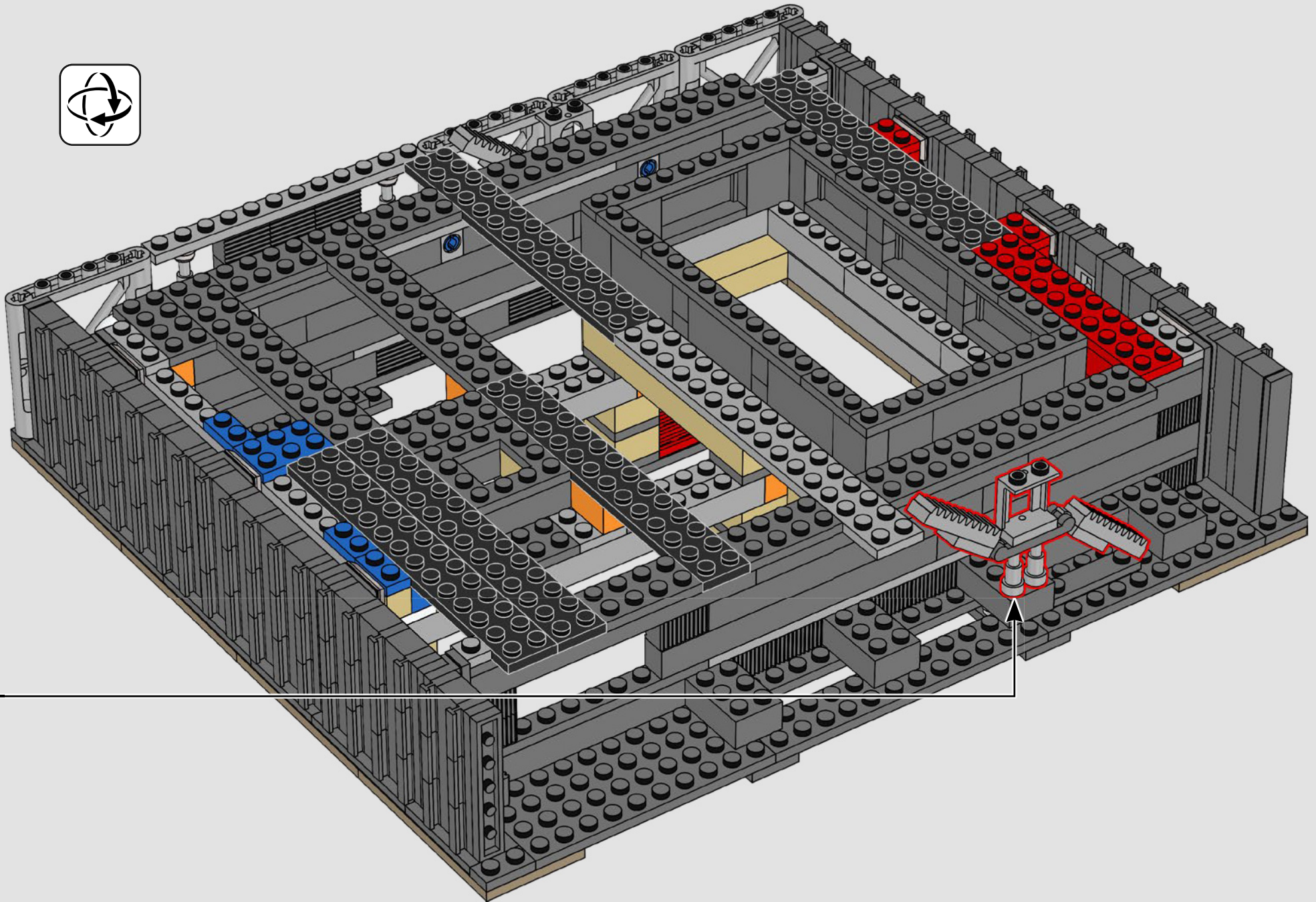

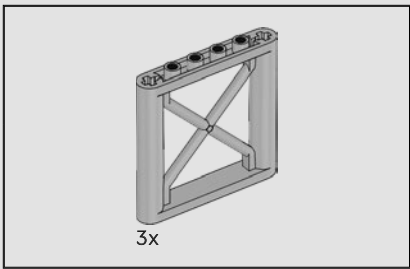

100

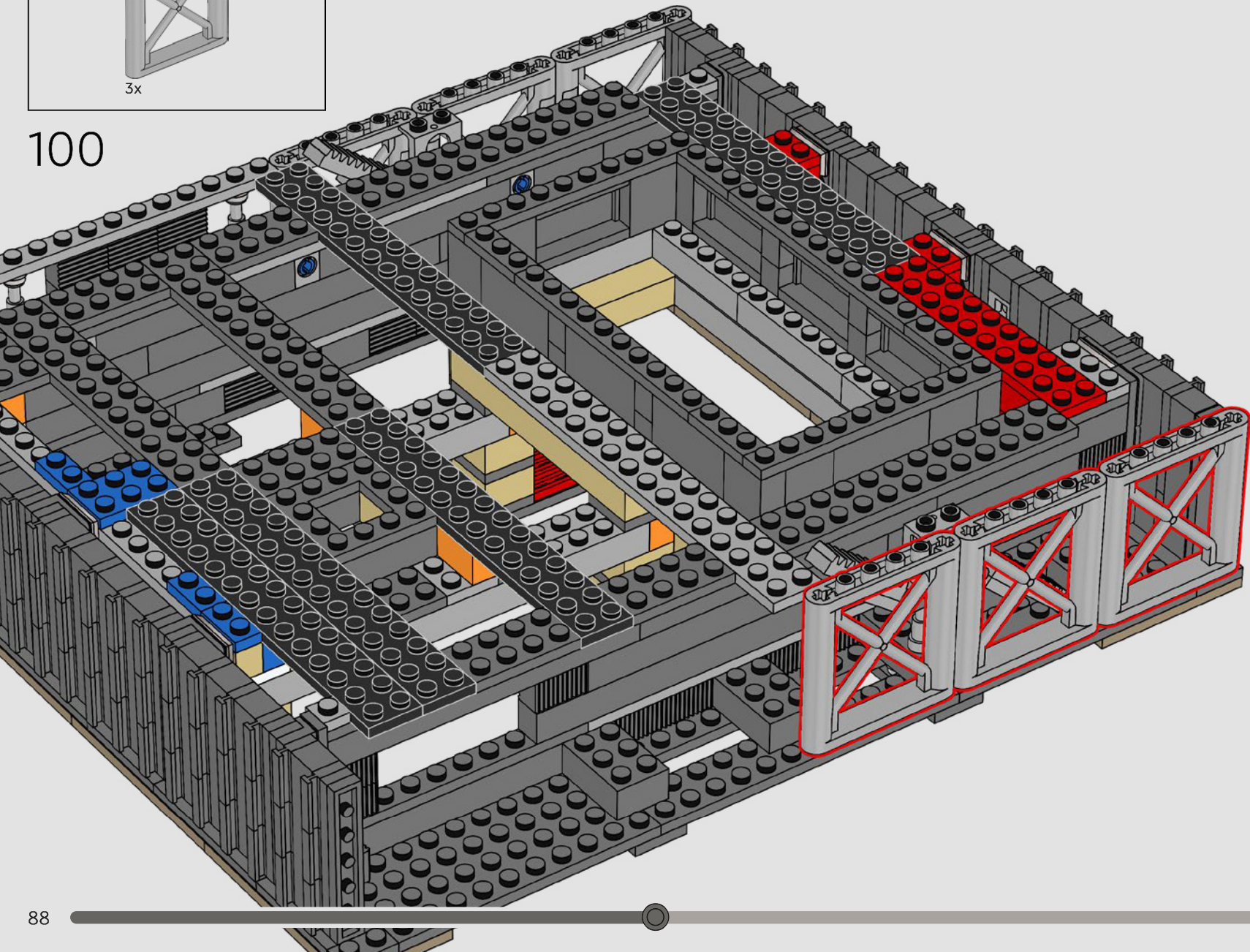



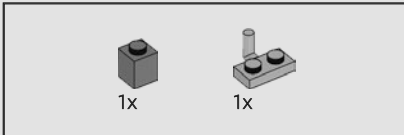
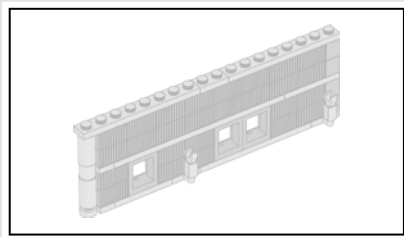

101

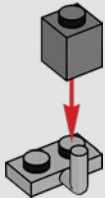

102

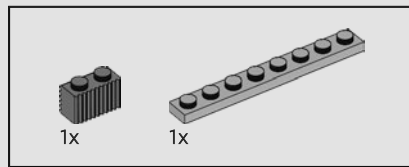
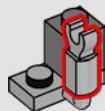

103

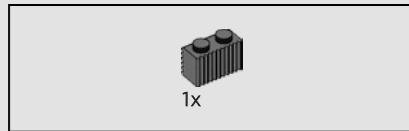
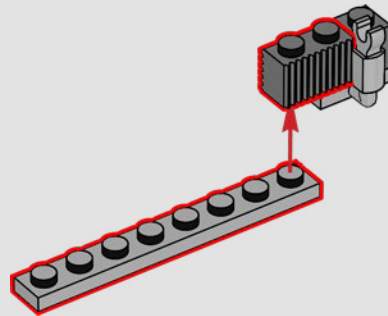

104

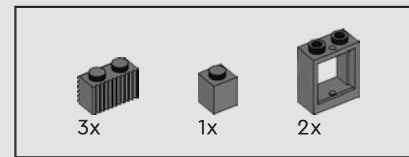
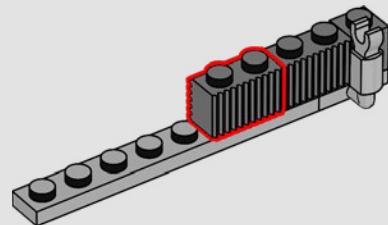

105

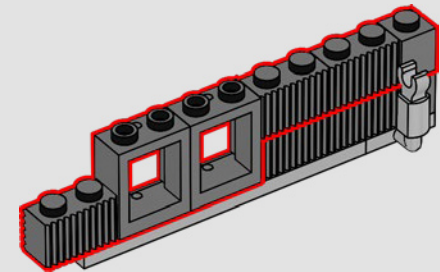

106

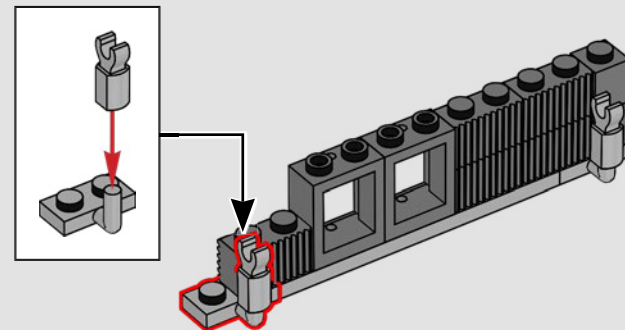

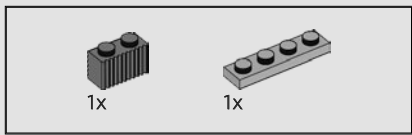

107

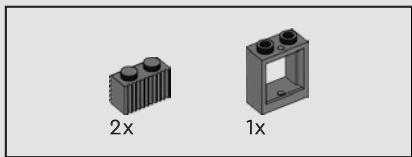
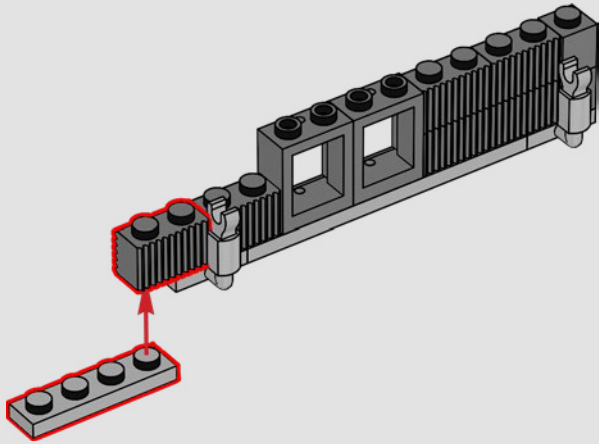

108

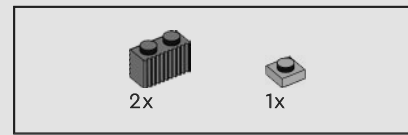
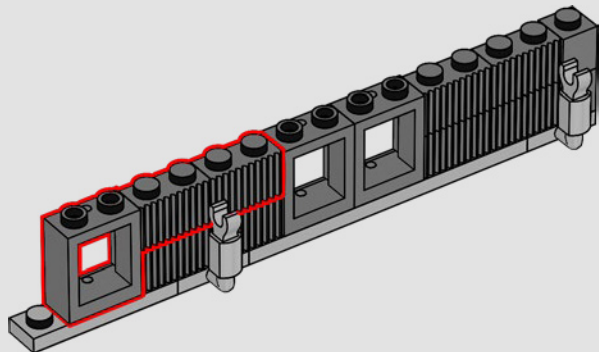

109

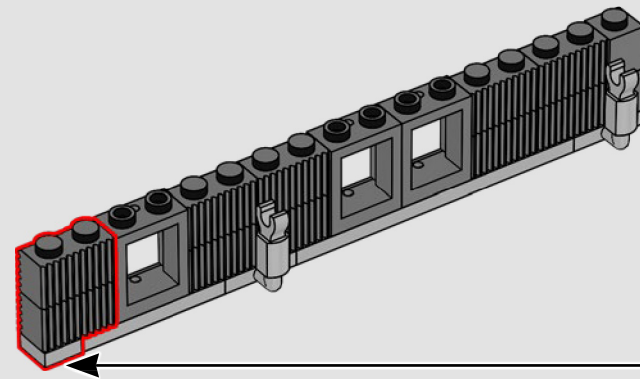
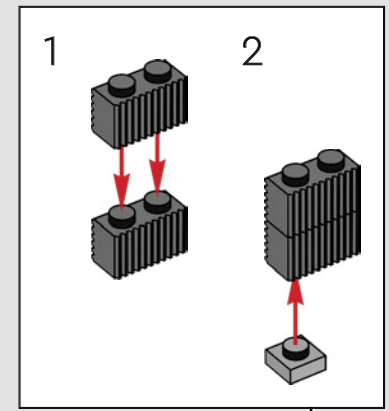

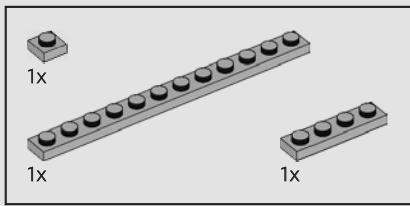

110

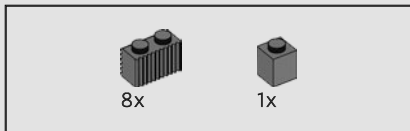
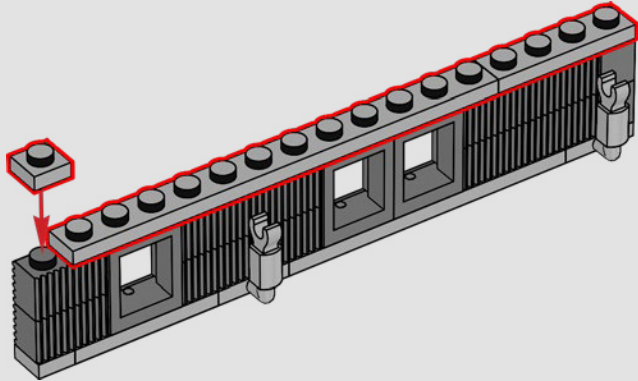

111

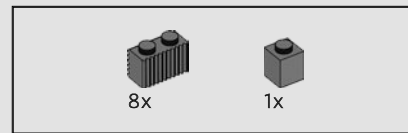
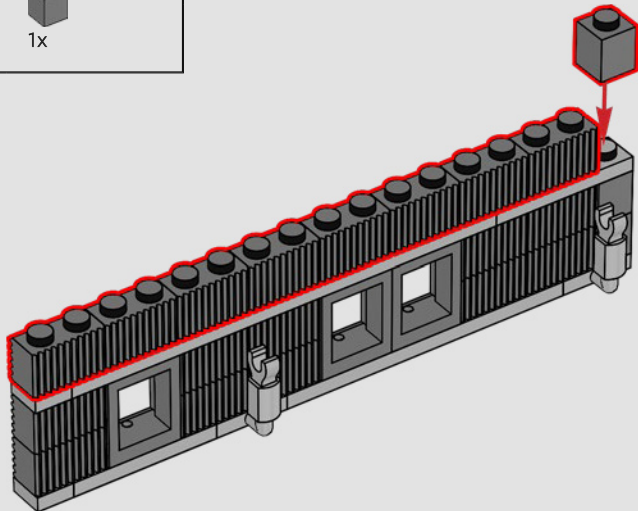

112

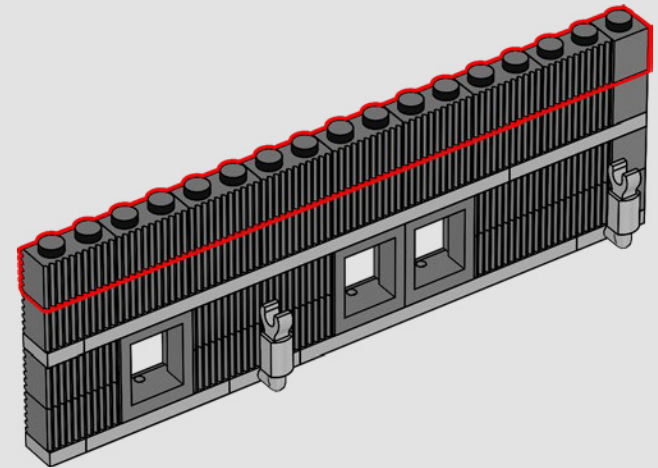

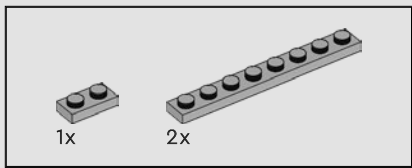

113

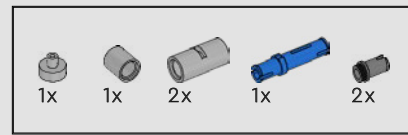
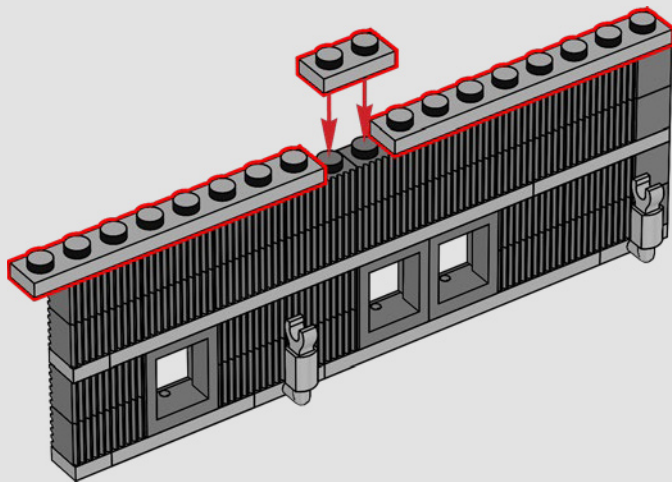

114

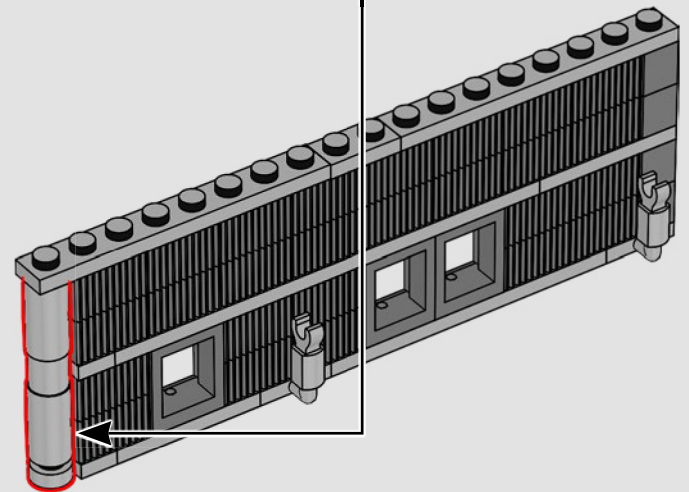
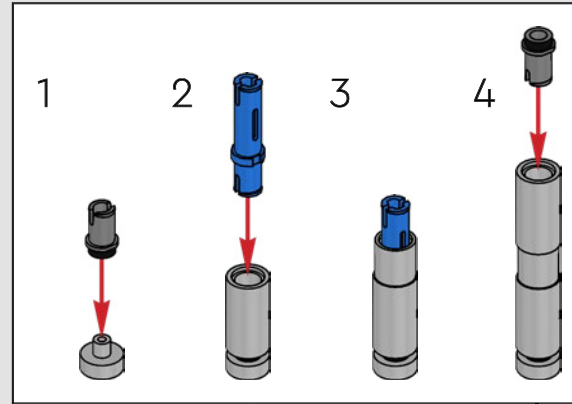

115

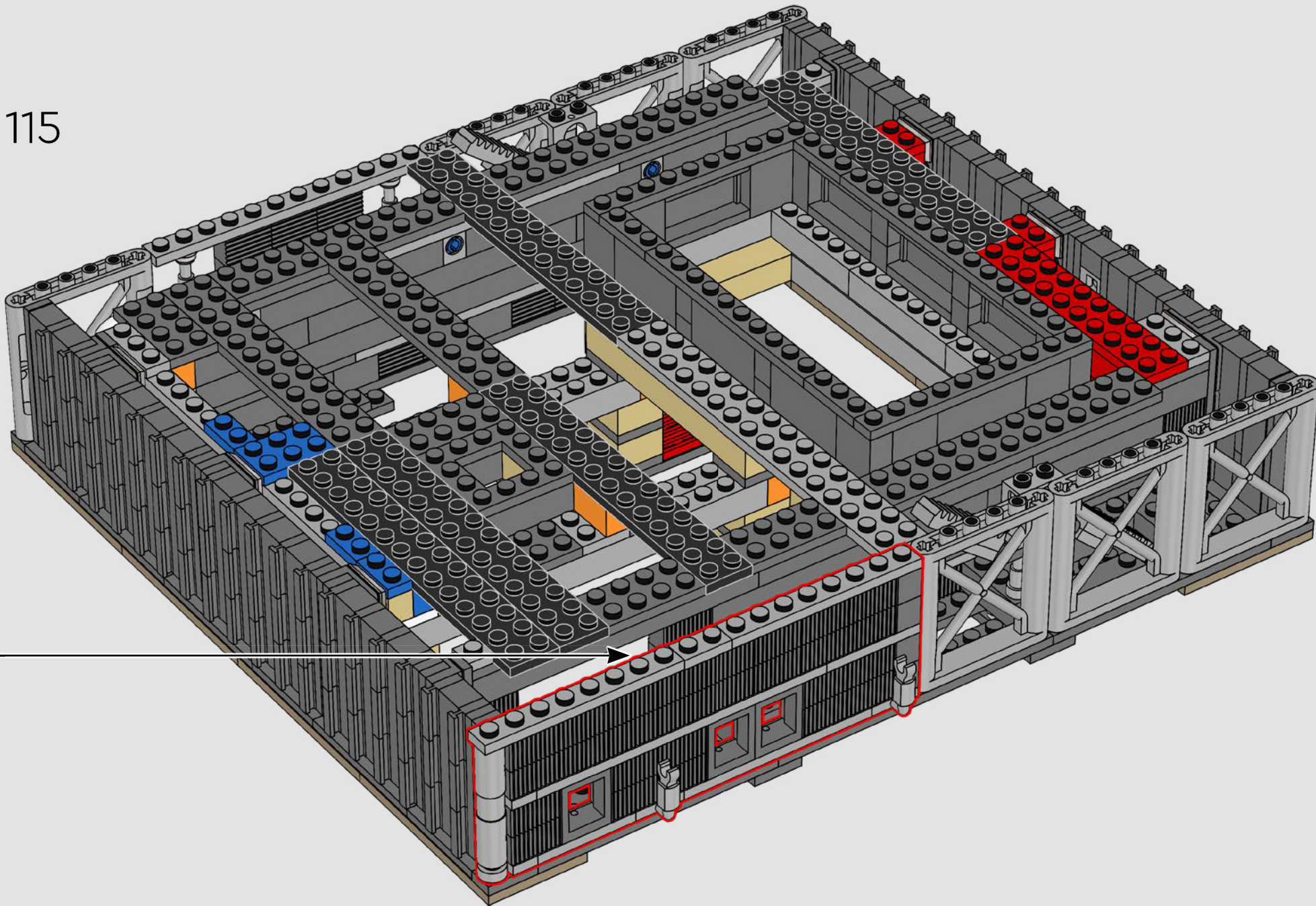

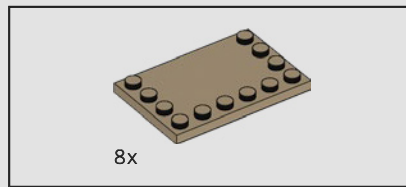

116

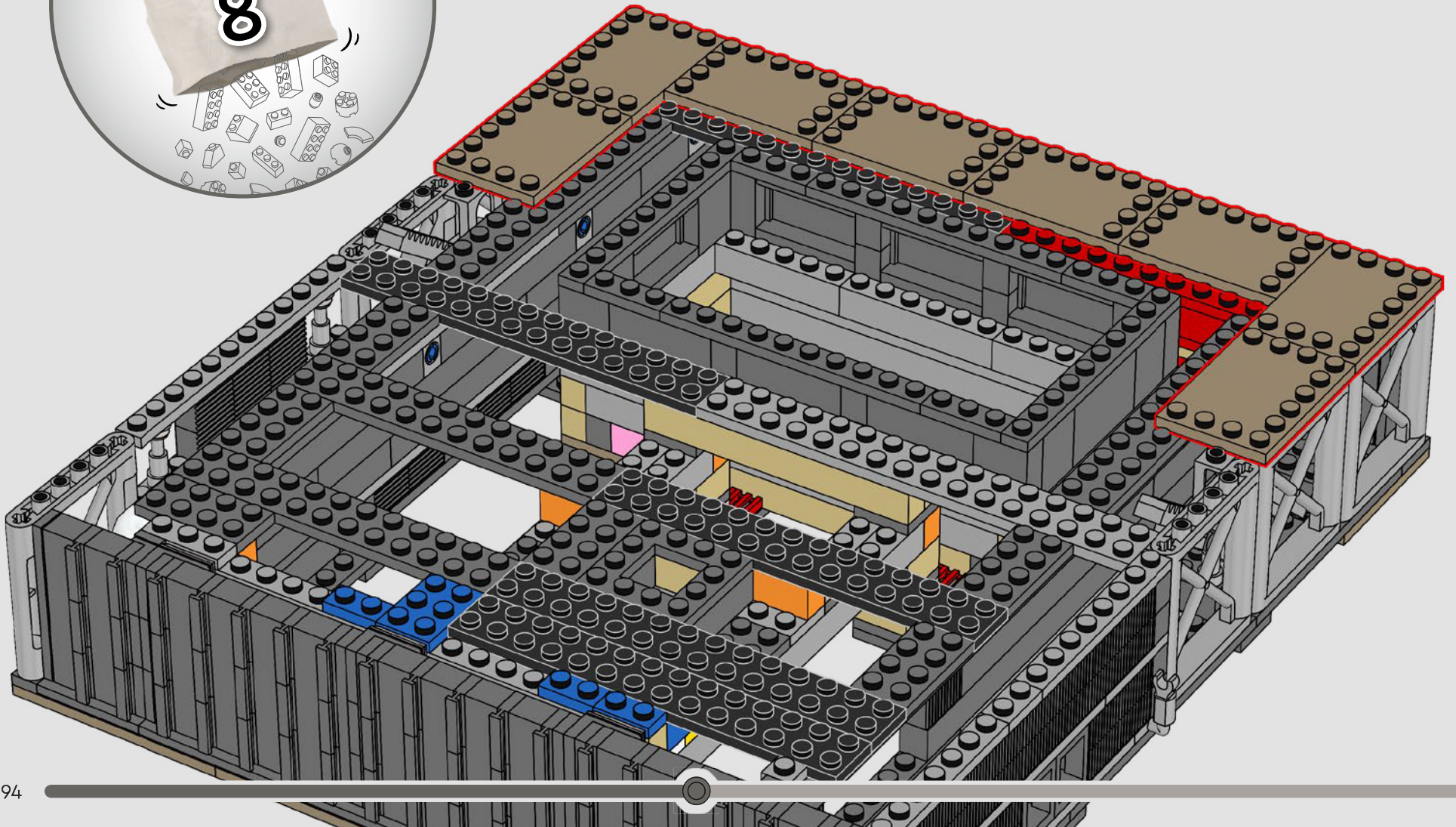

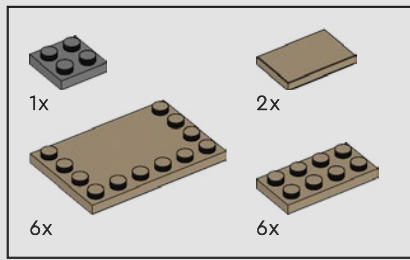

117

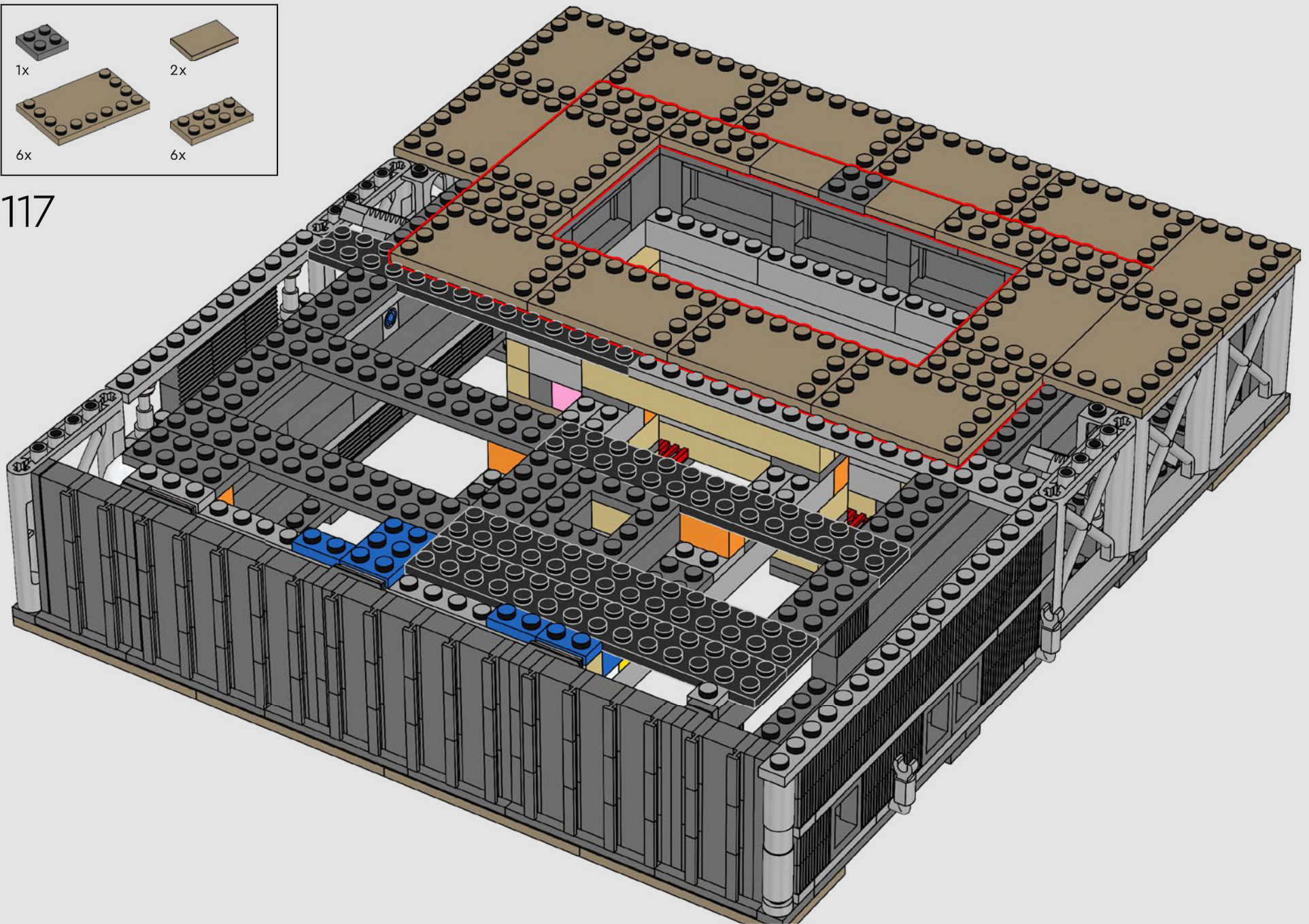

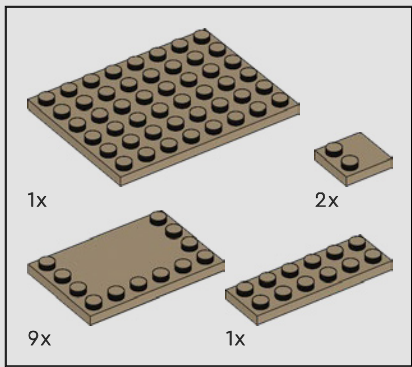

118

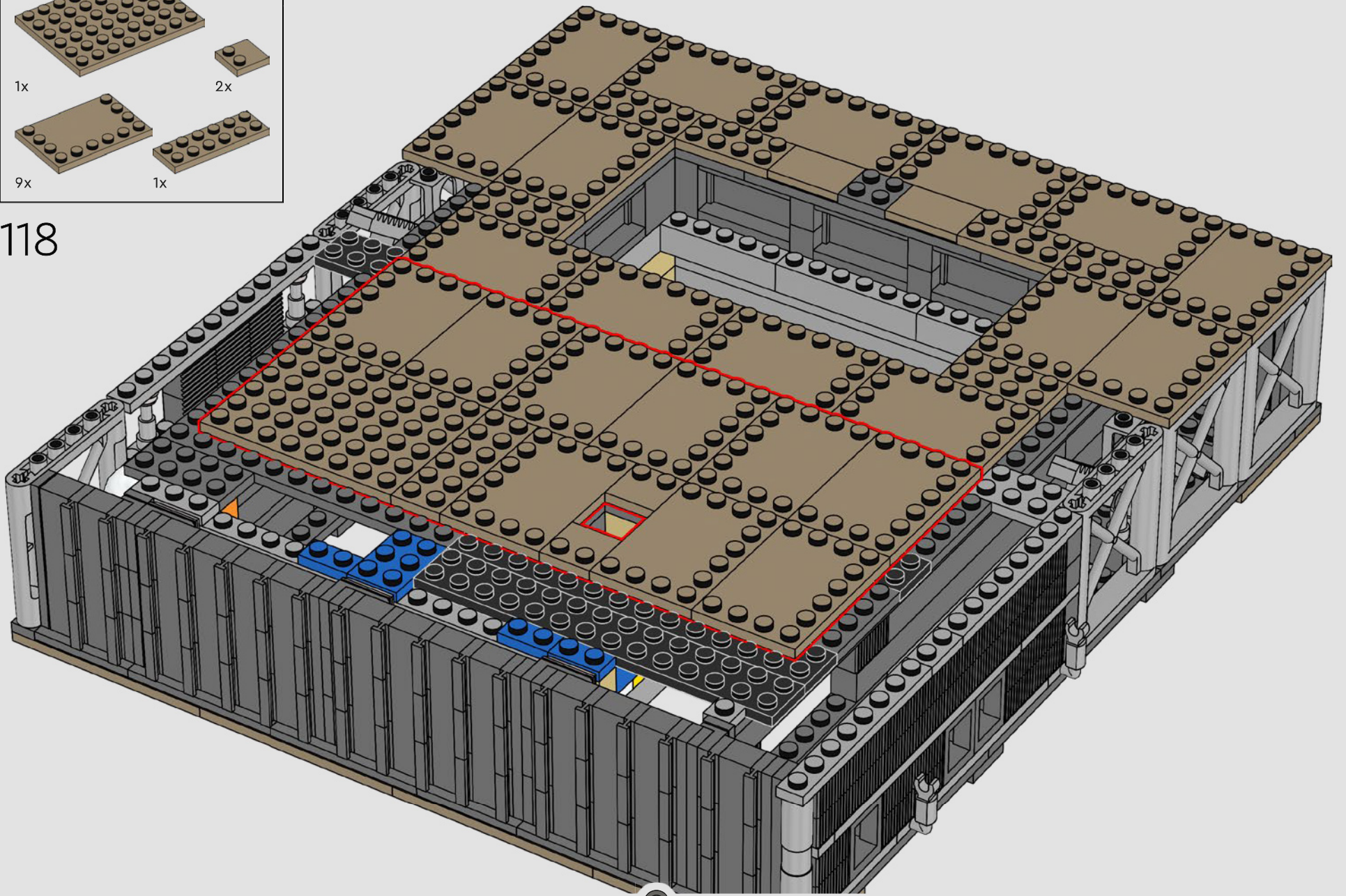



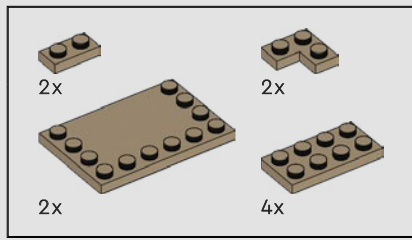

119

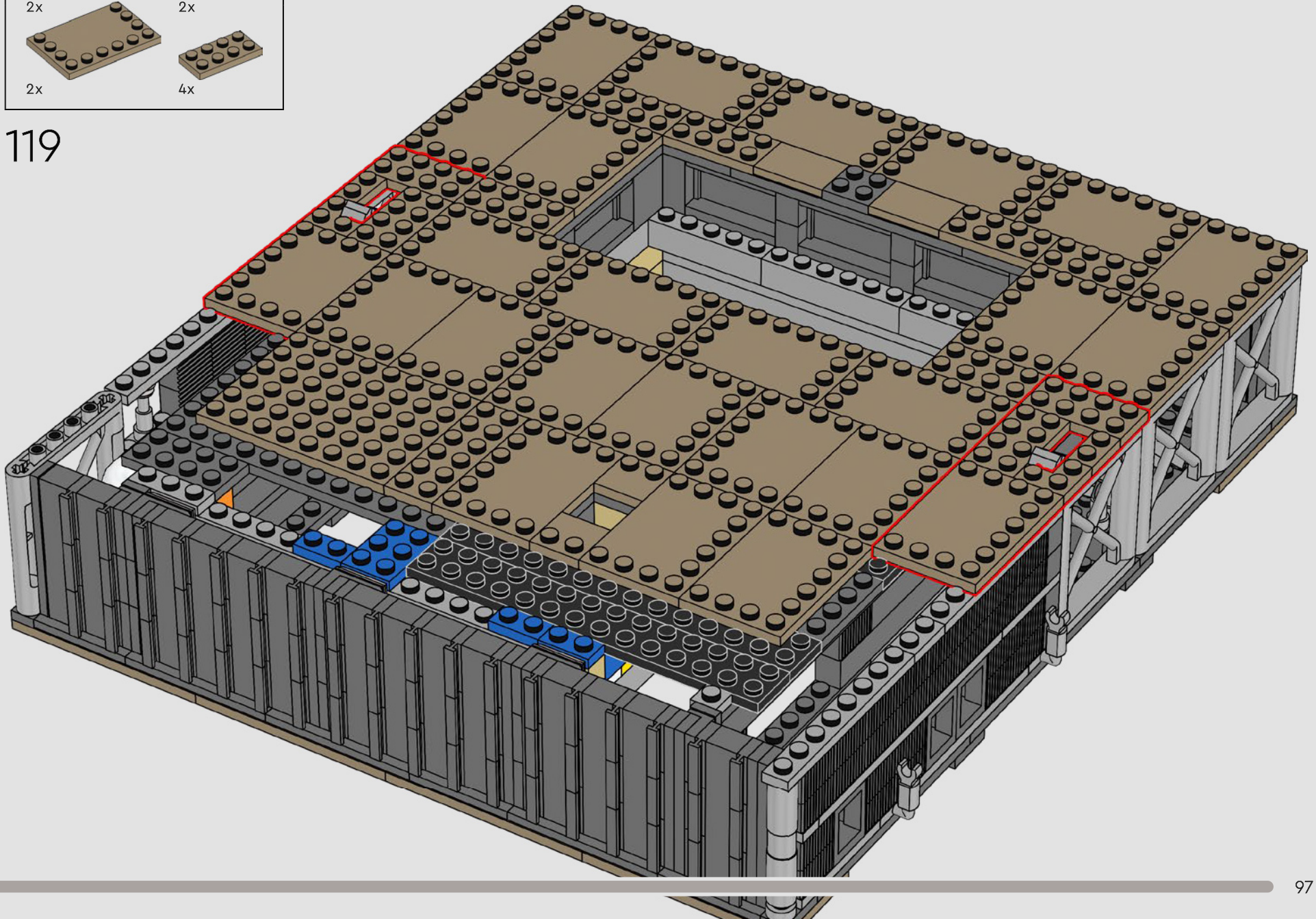

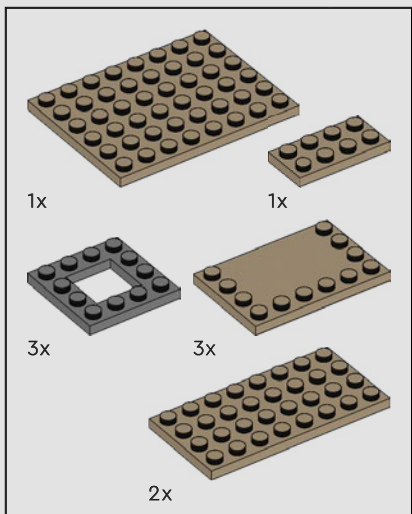

120

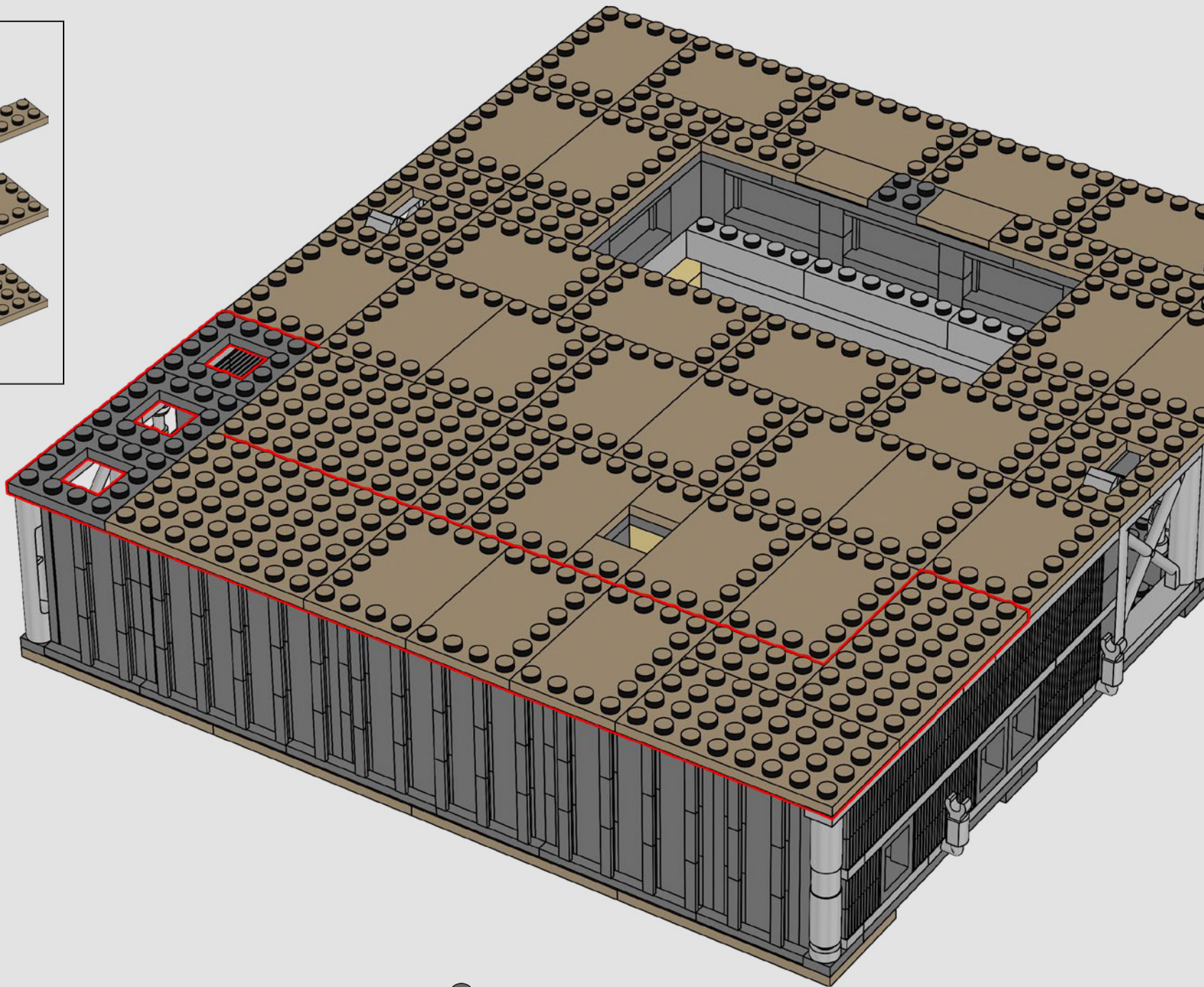

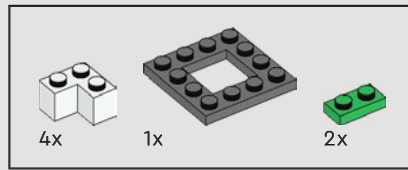

121

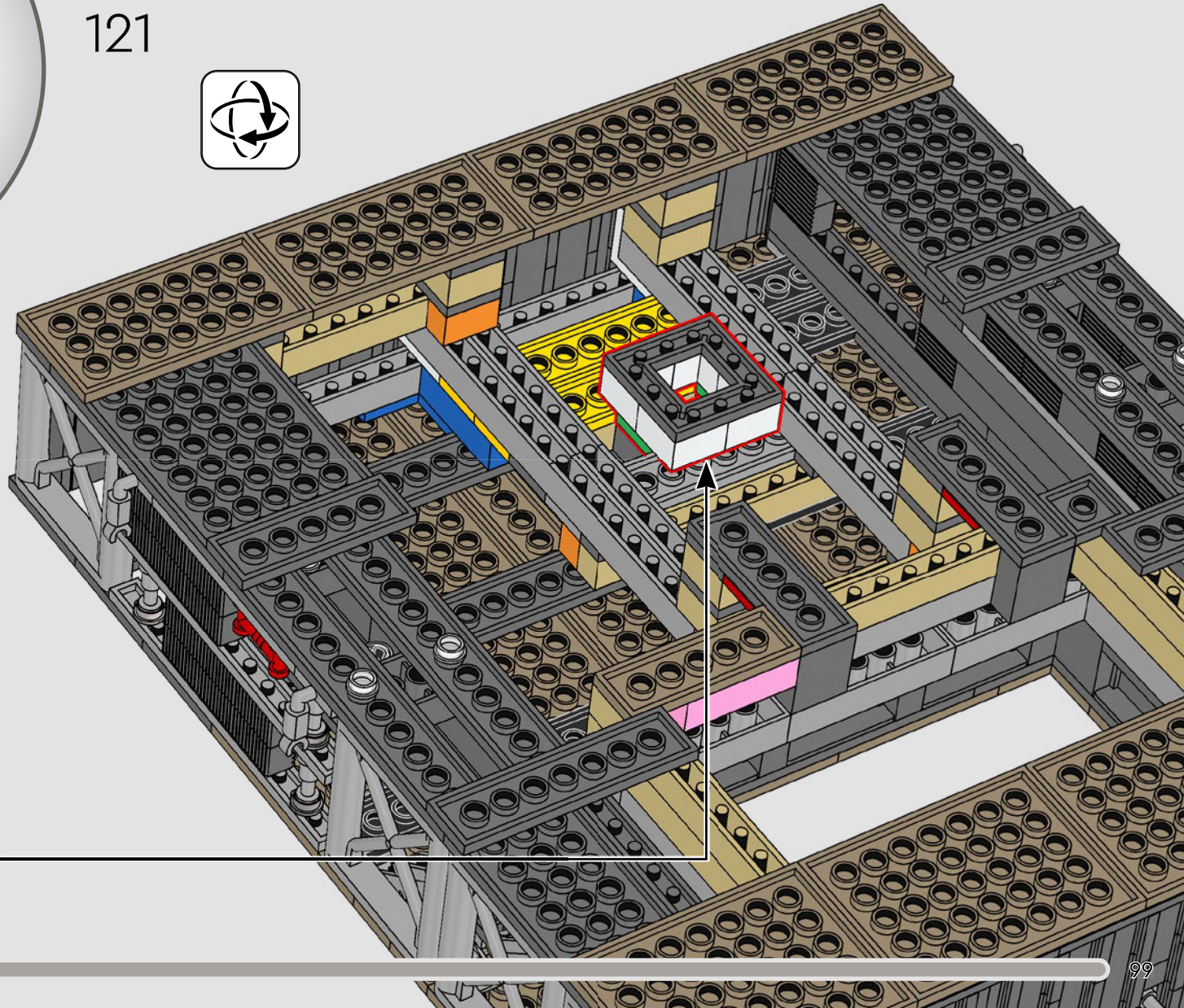
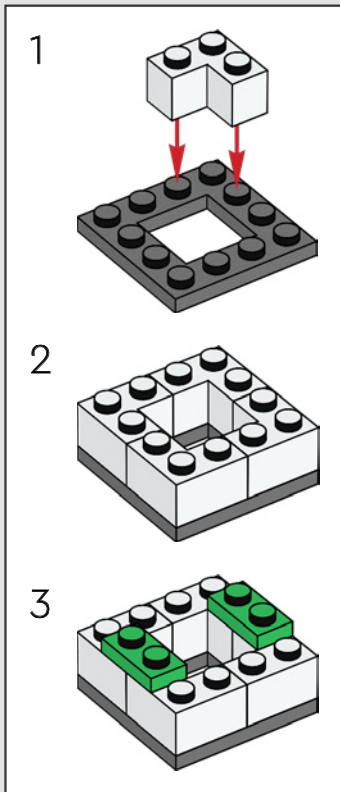

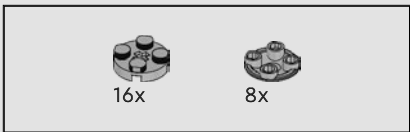

122

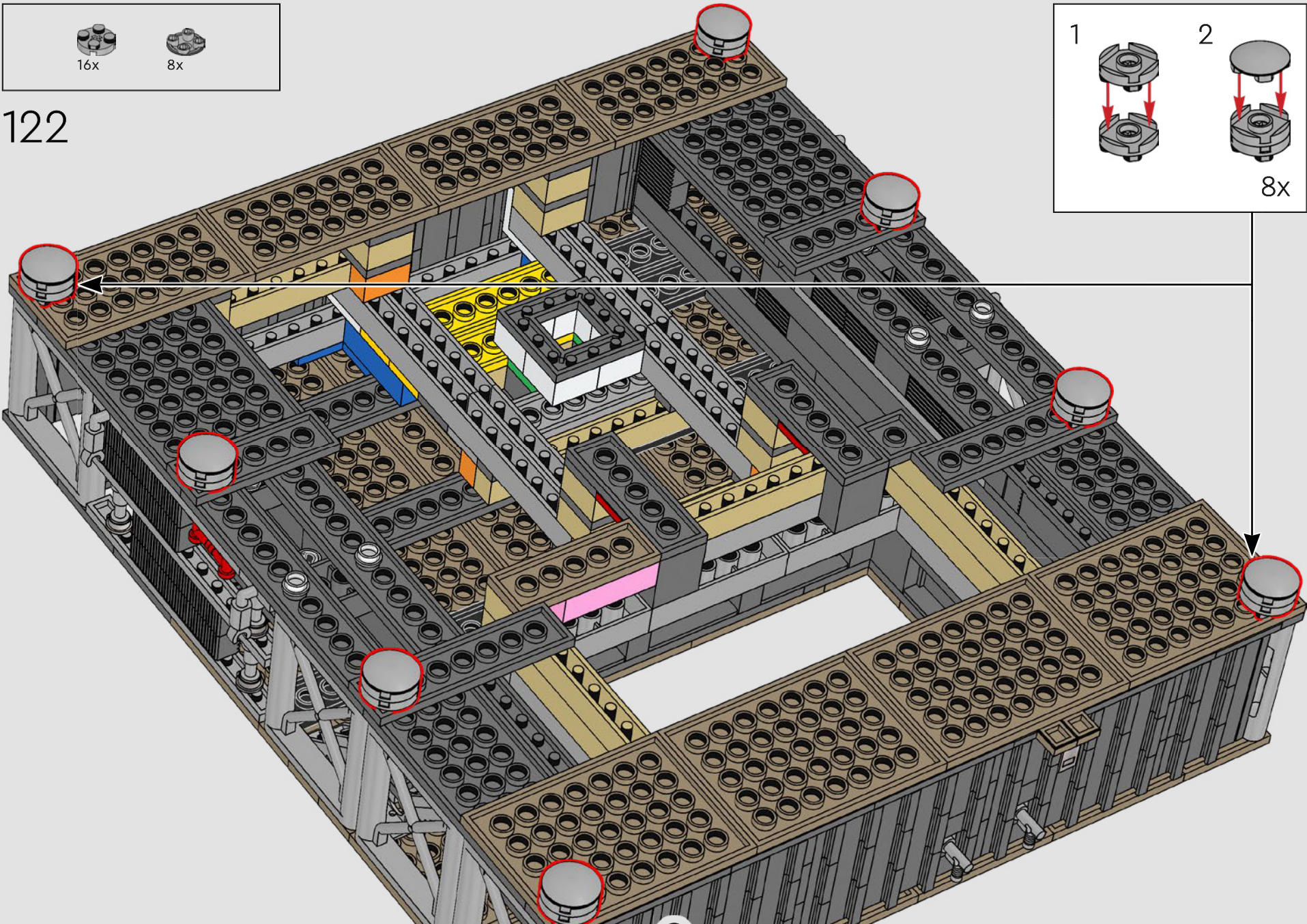
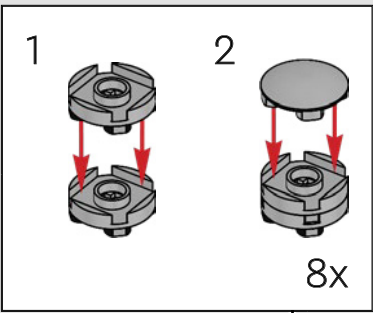

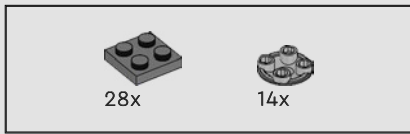

123

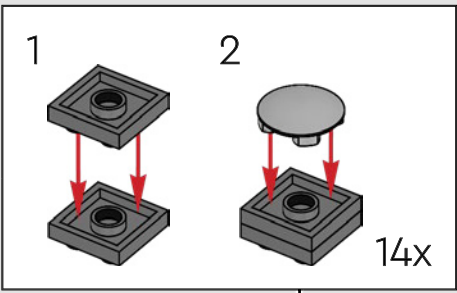
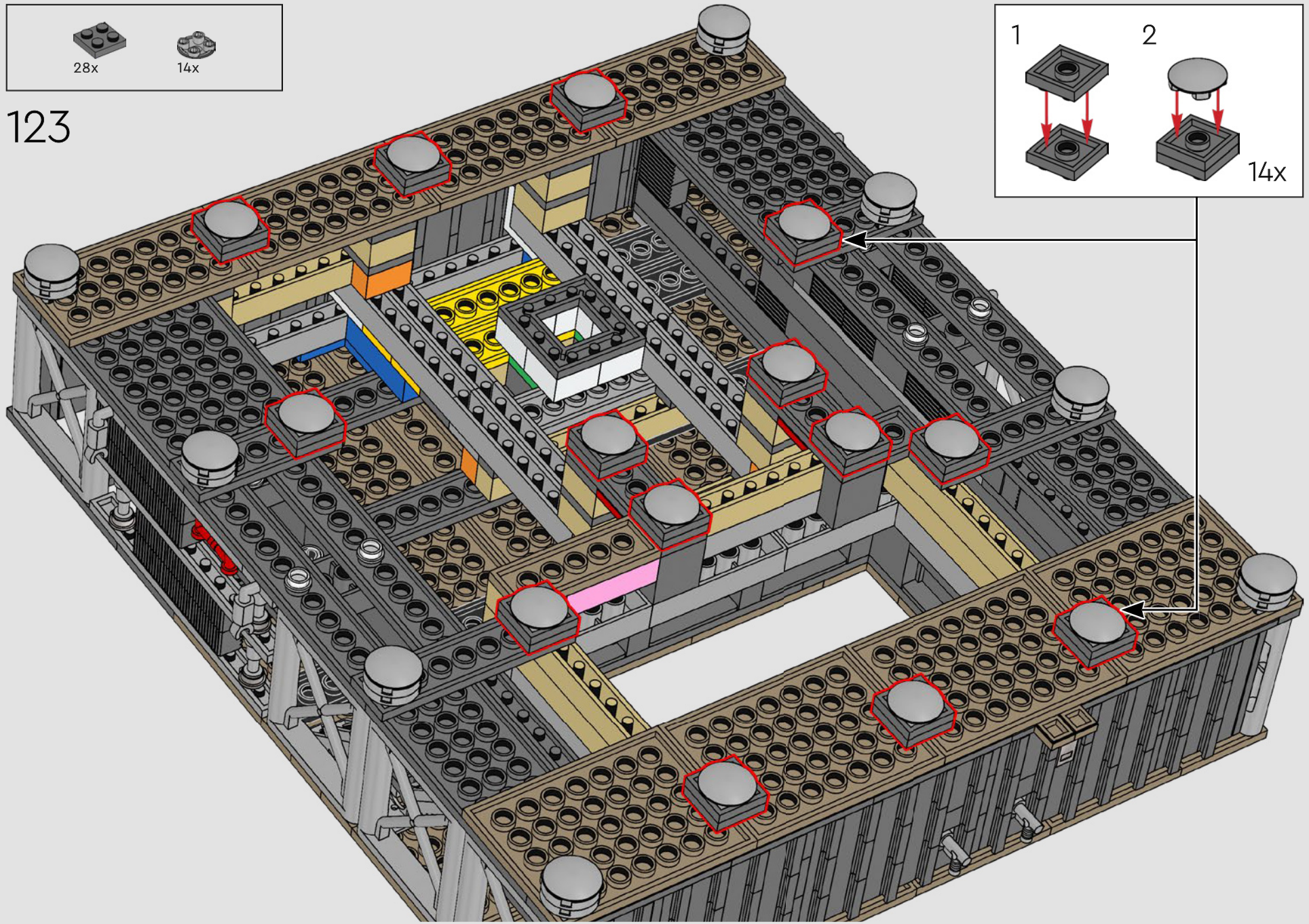

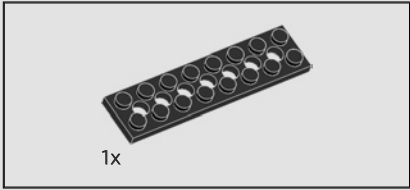
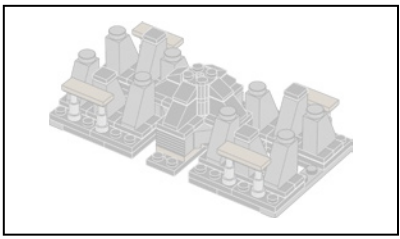

124

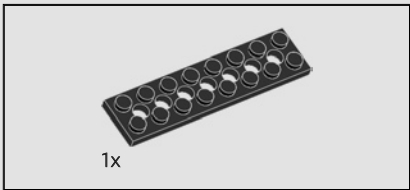

125

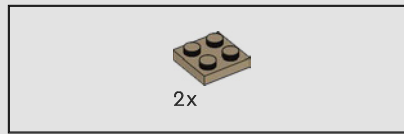
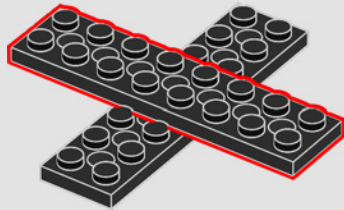
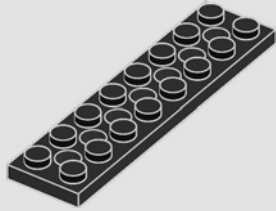

126

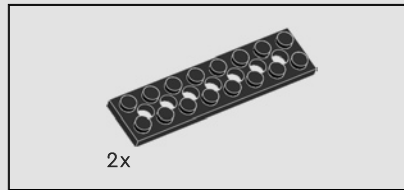
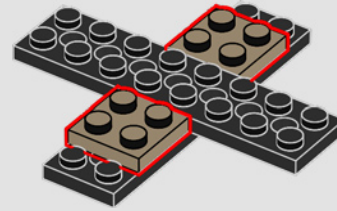

127

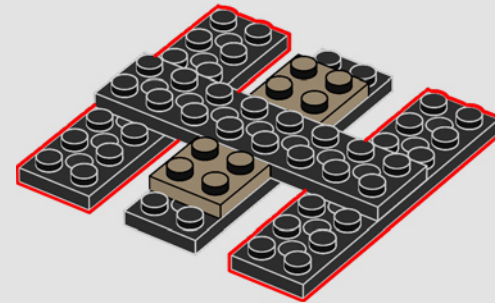

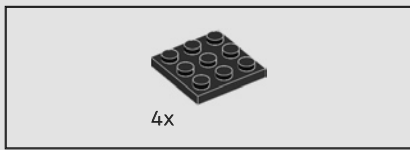

128

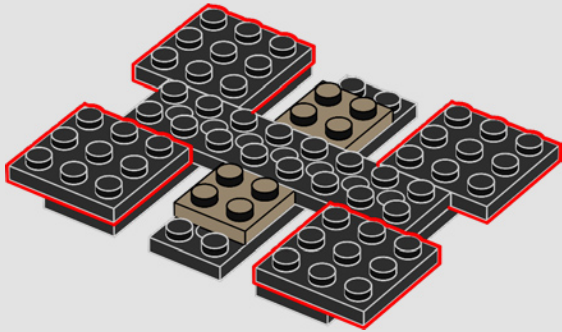

129

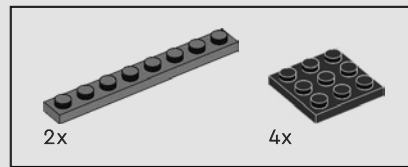
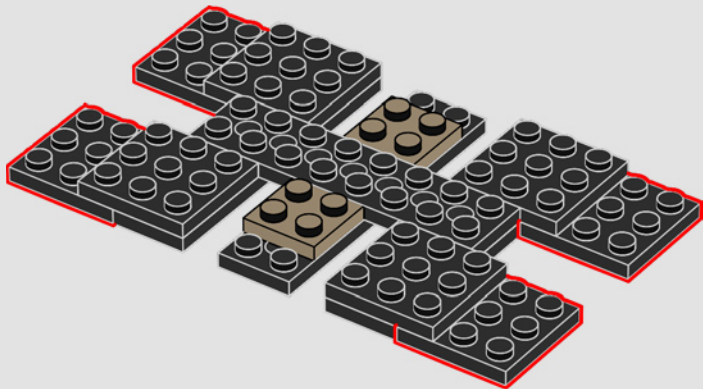

130

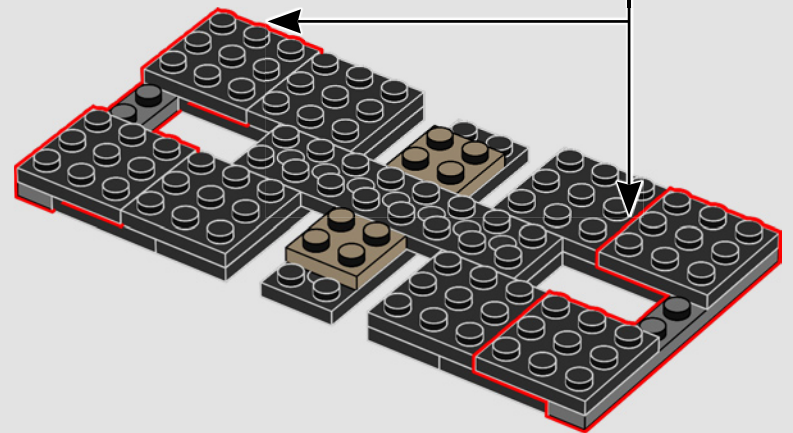
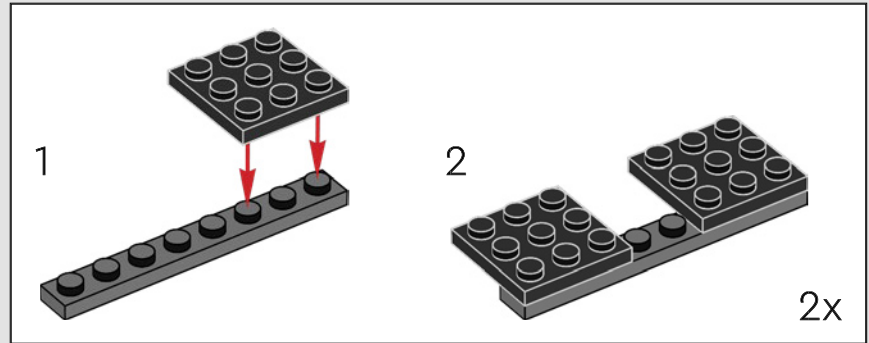



24x

131

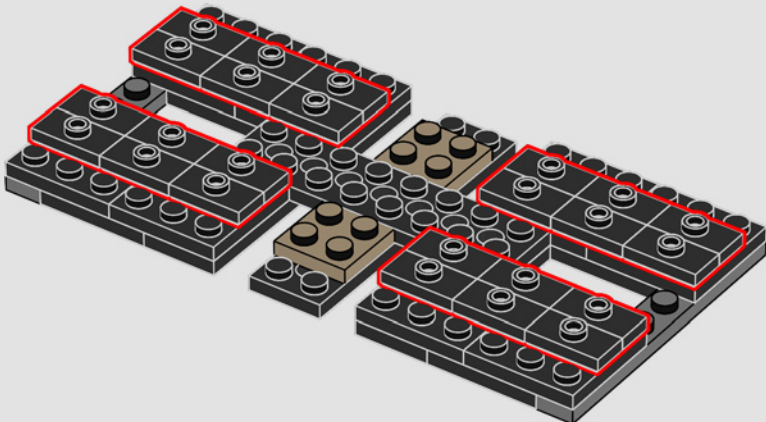

4x

132

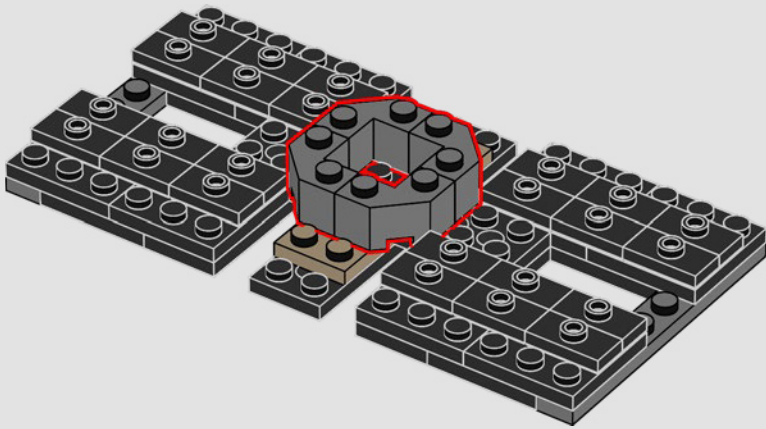

4x

133

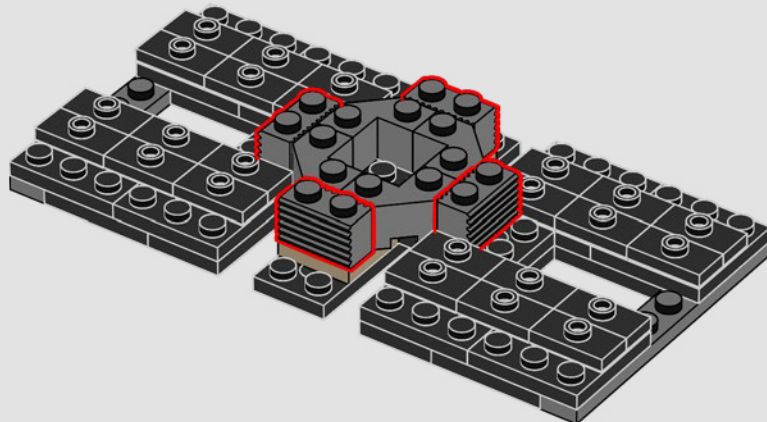

8x

134

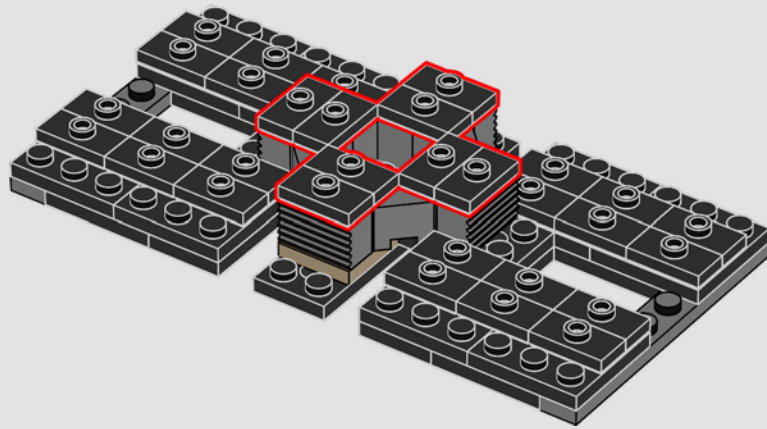





135

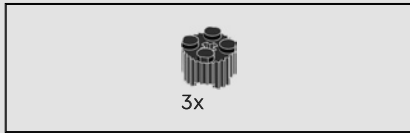
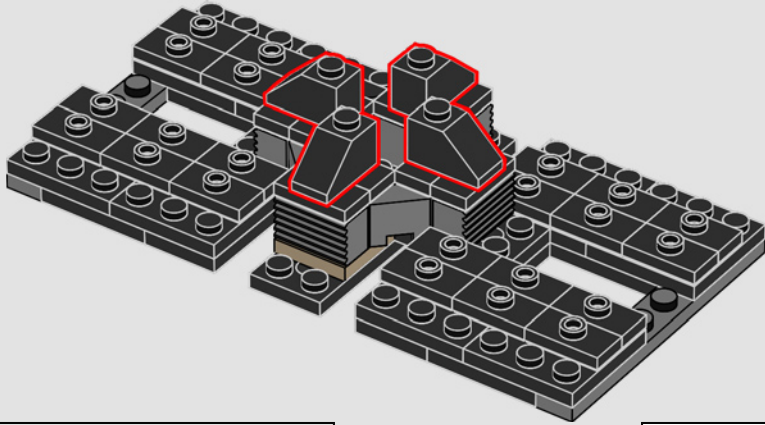

136

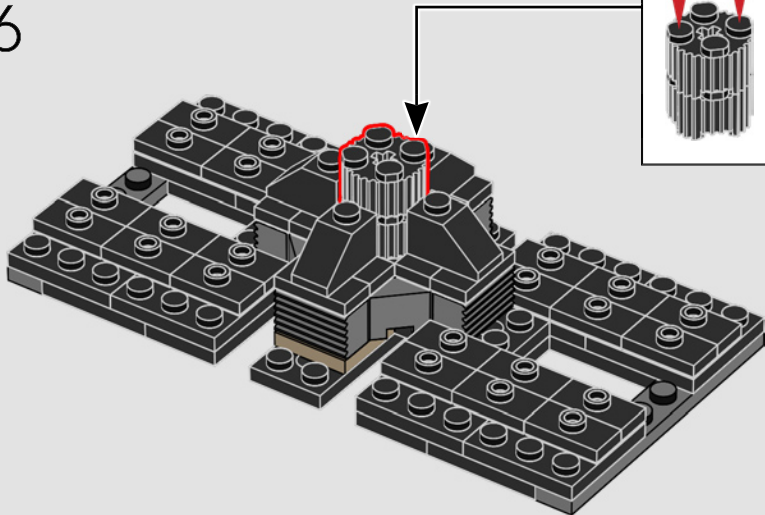

137

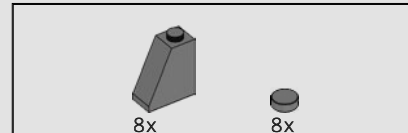
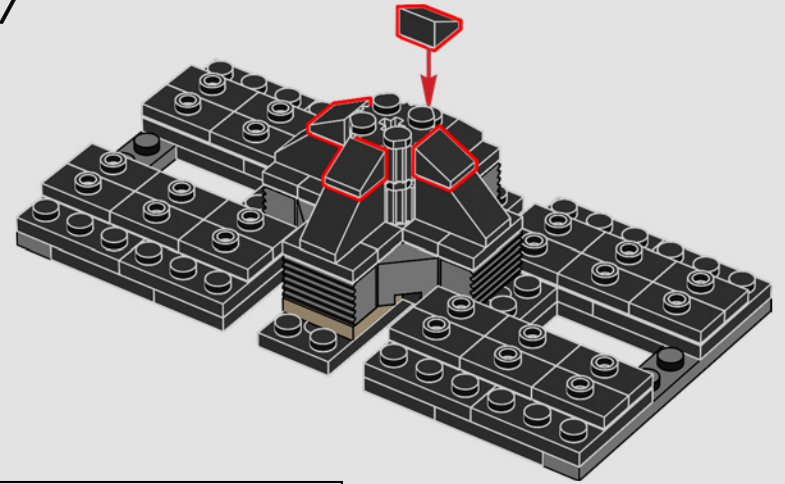

138

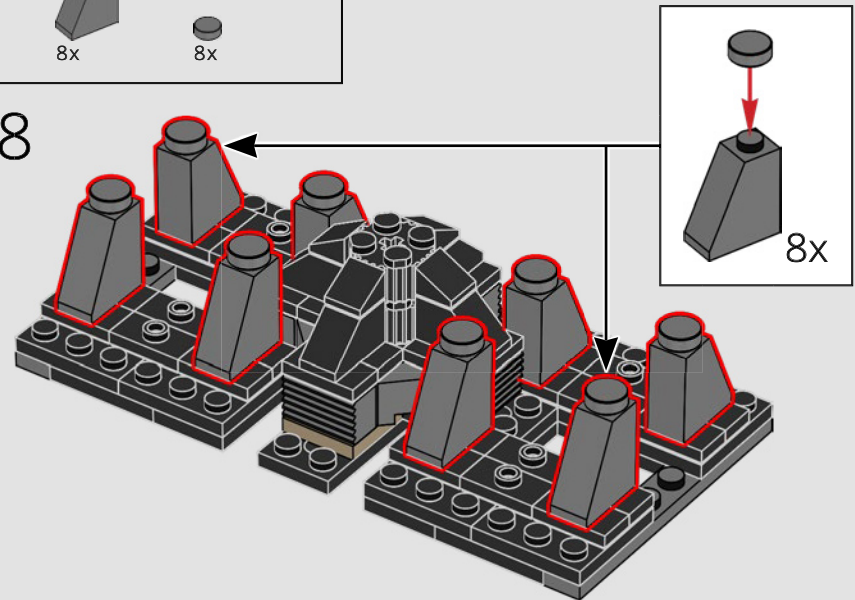

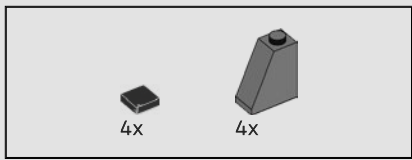

139

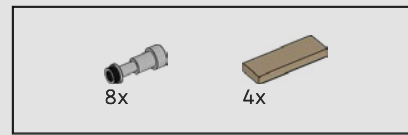
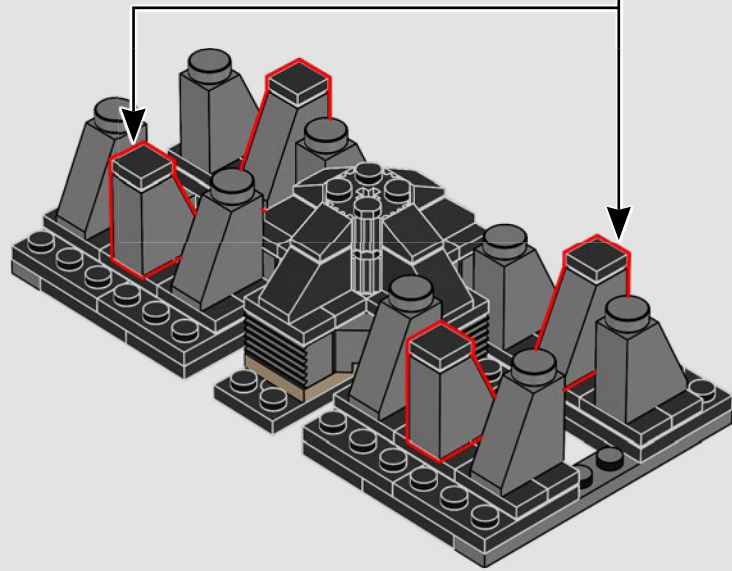
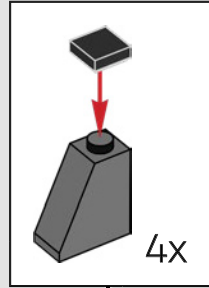

140

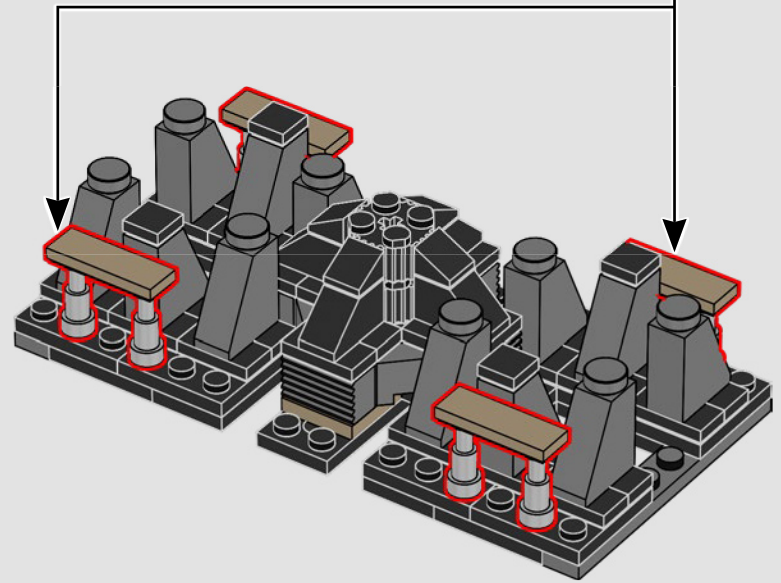
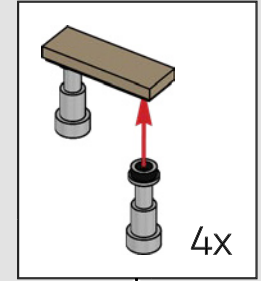

141

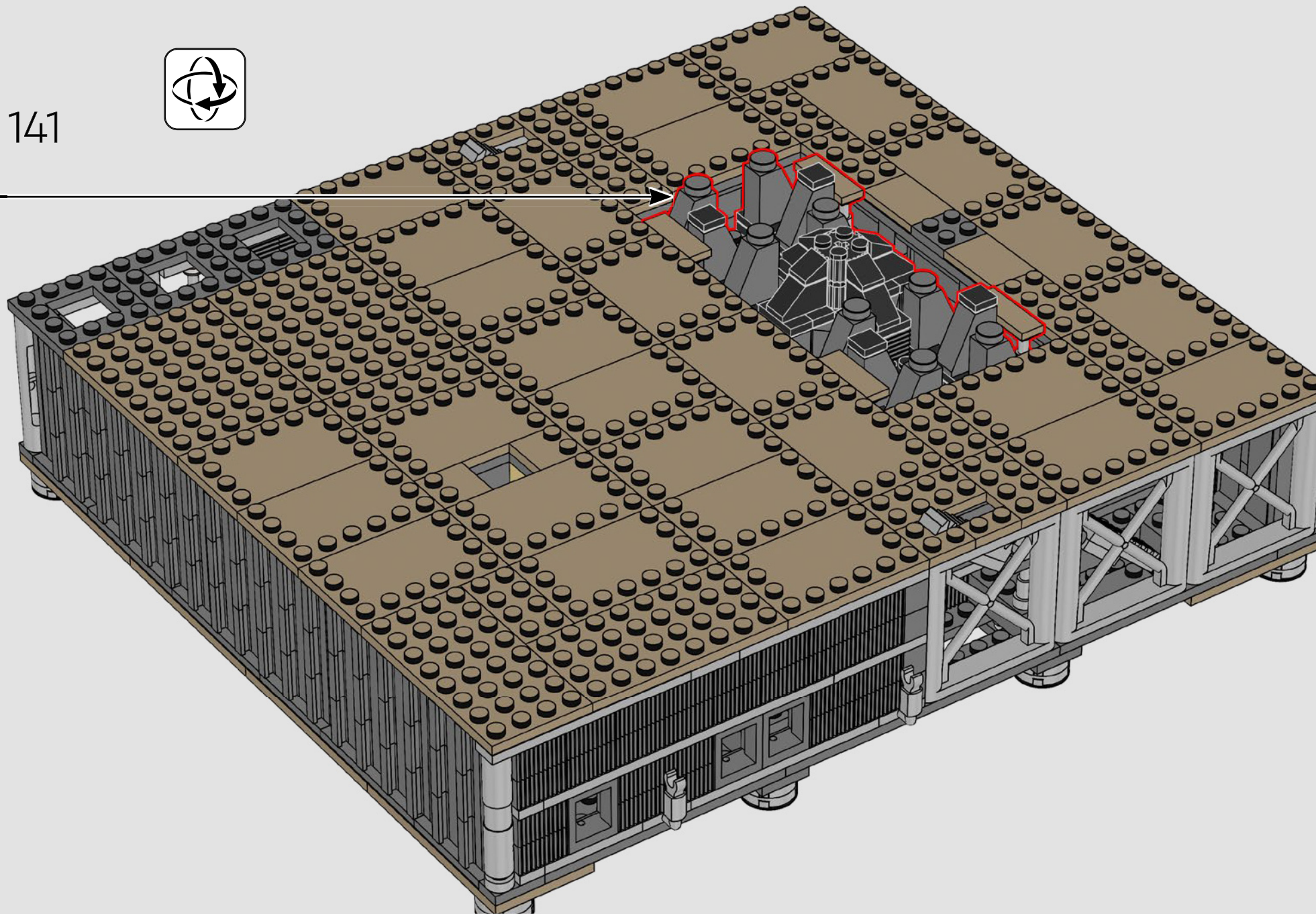

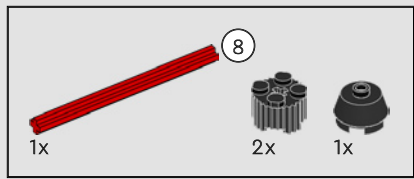

142

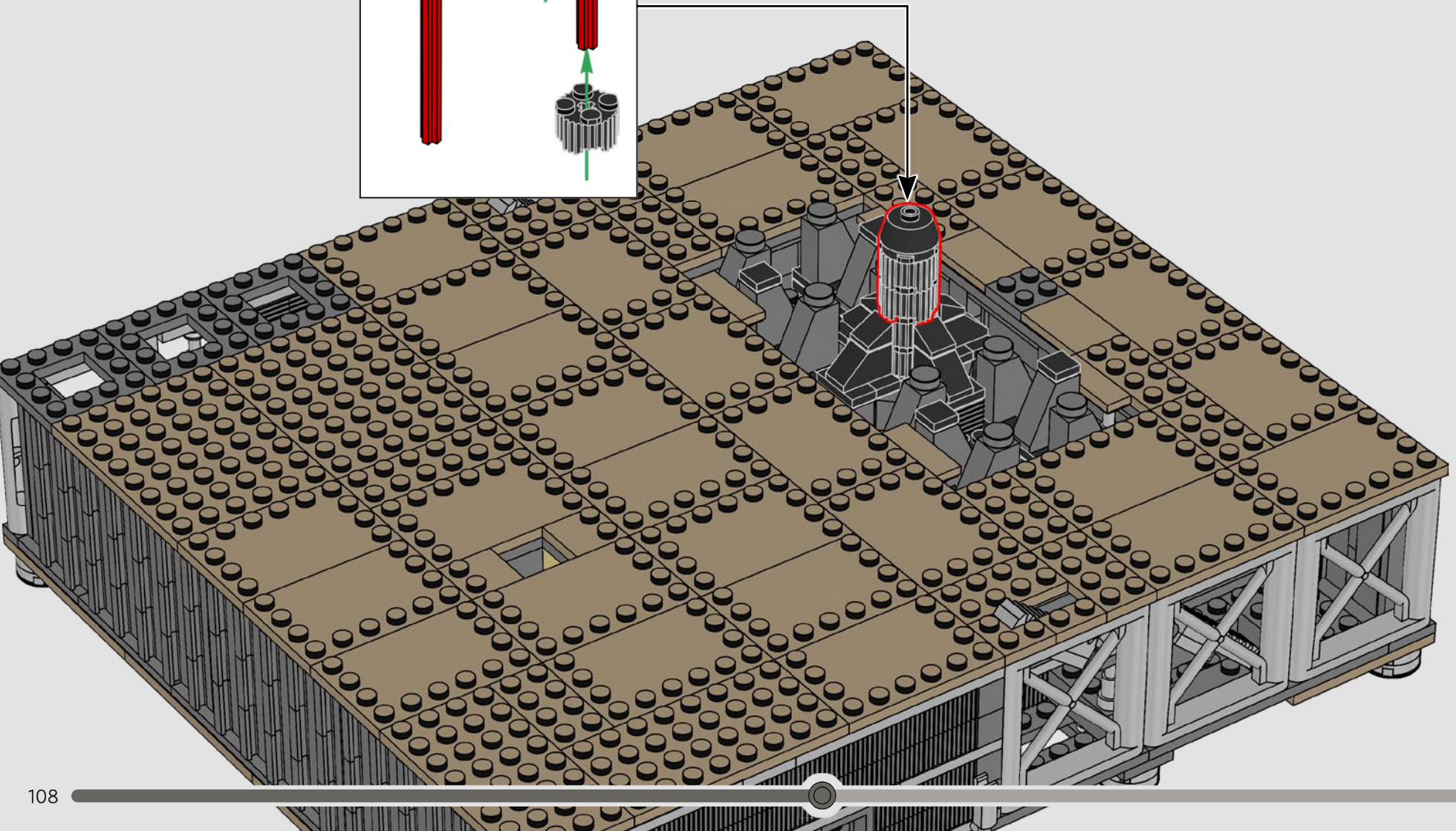
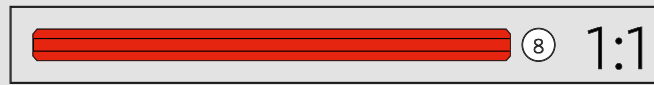
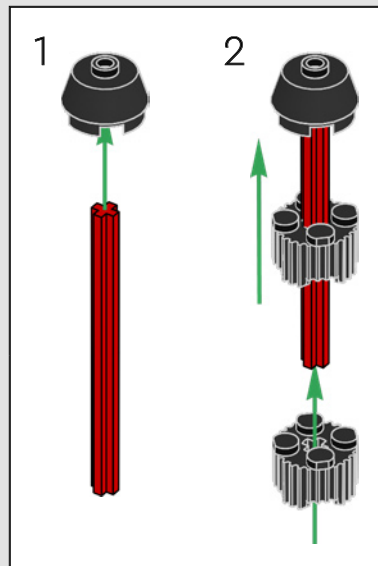

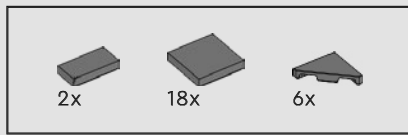

143

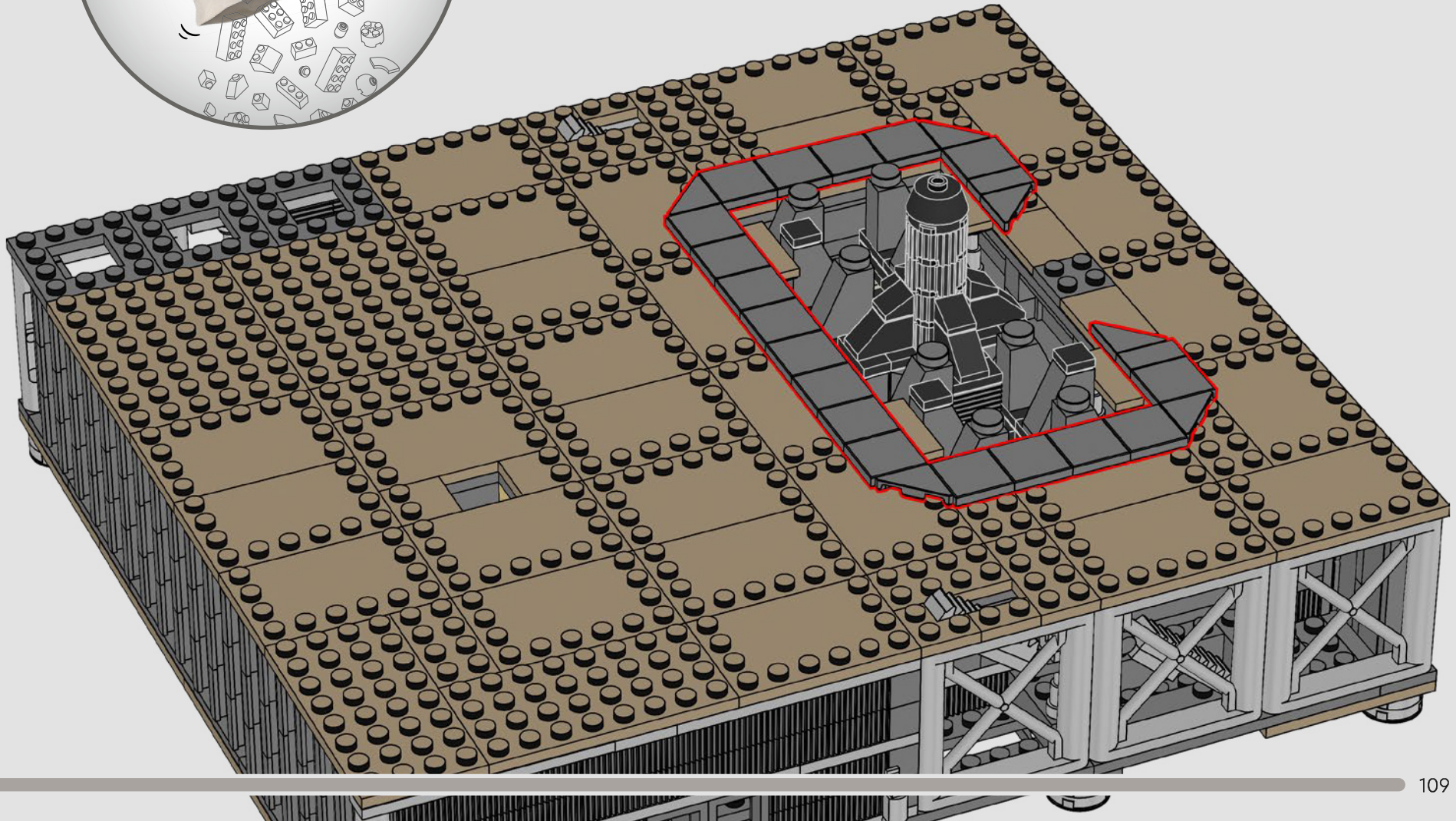

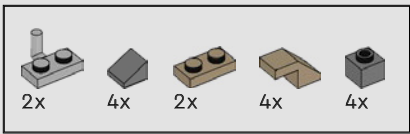

144

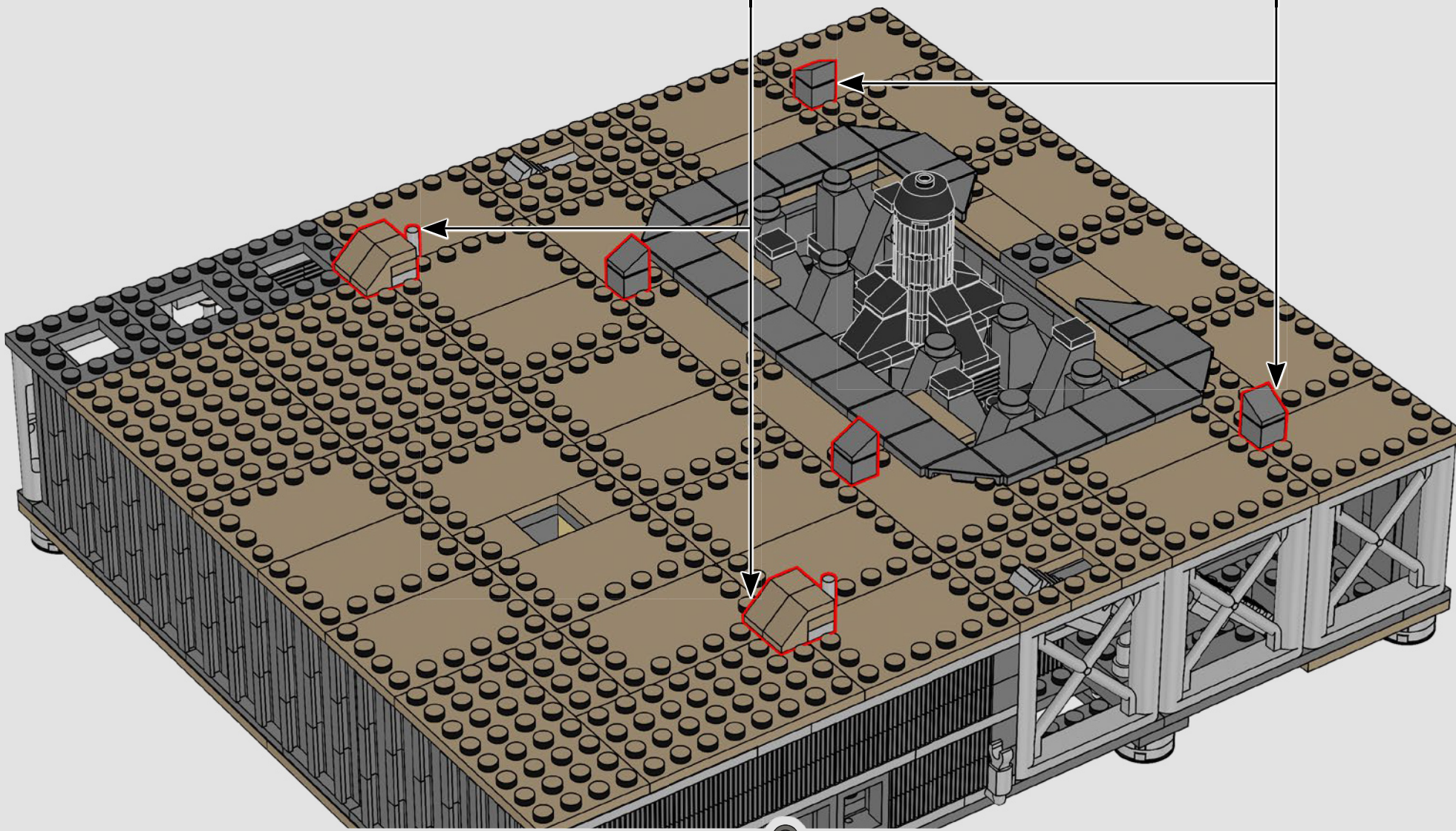
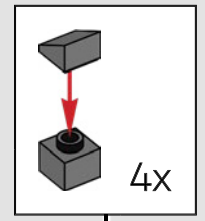
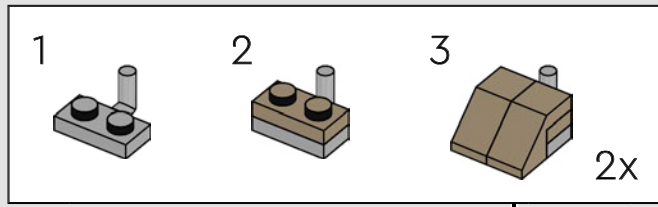

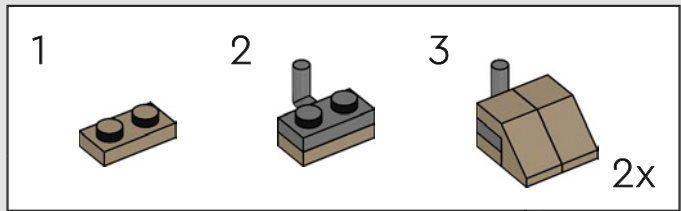
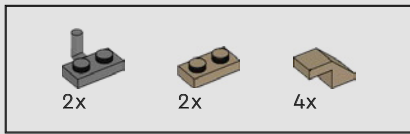

145

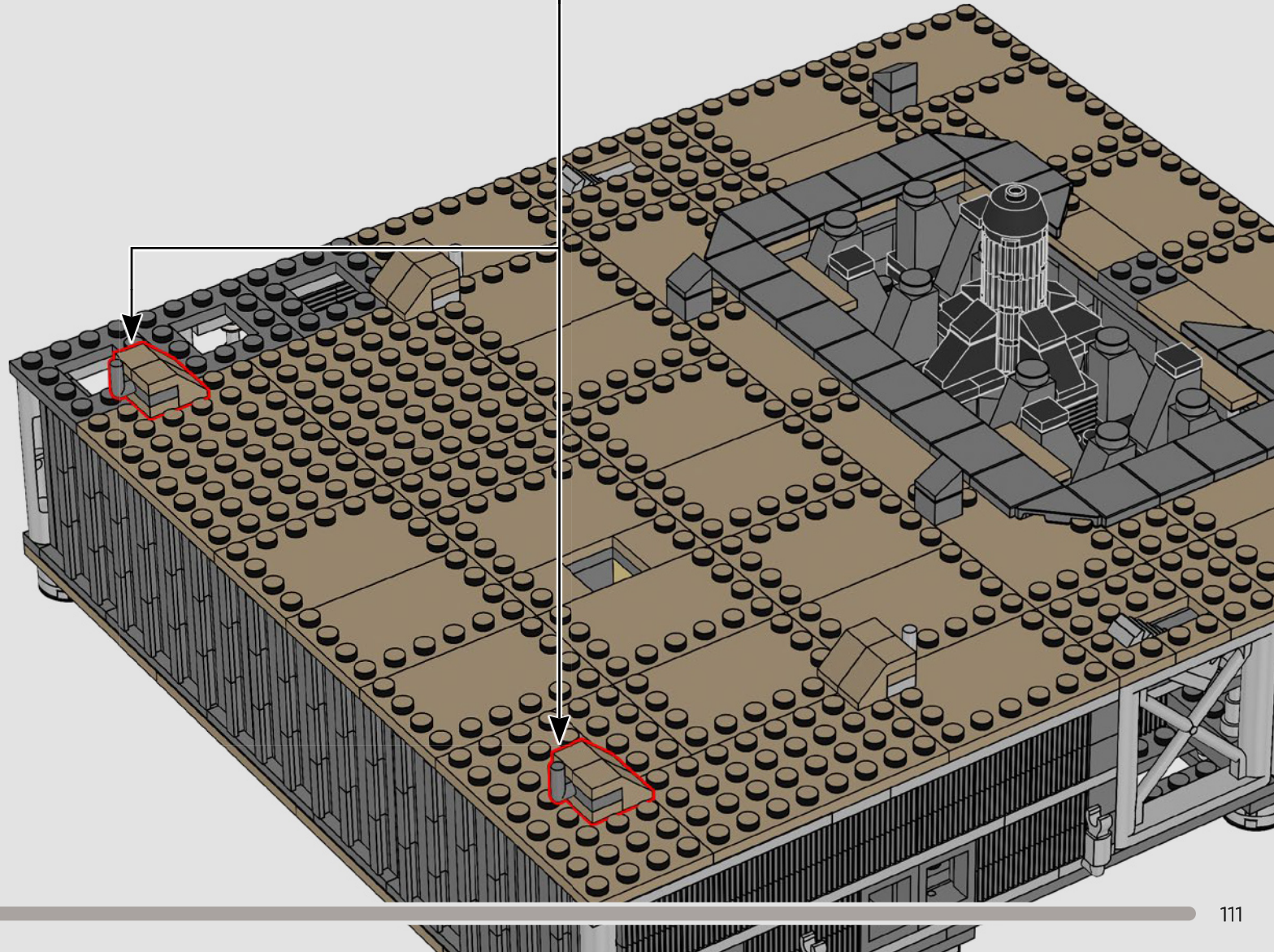



88x

146

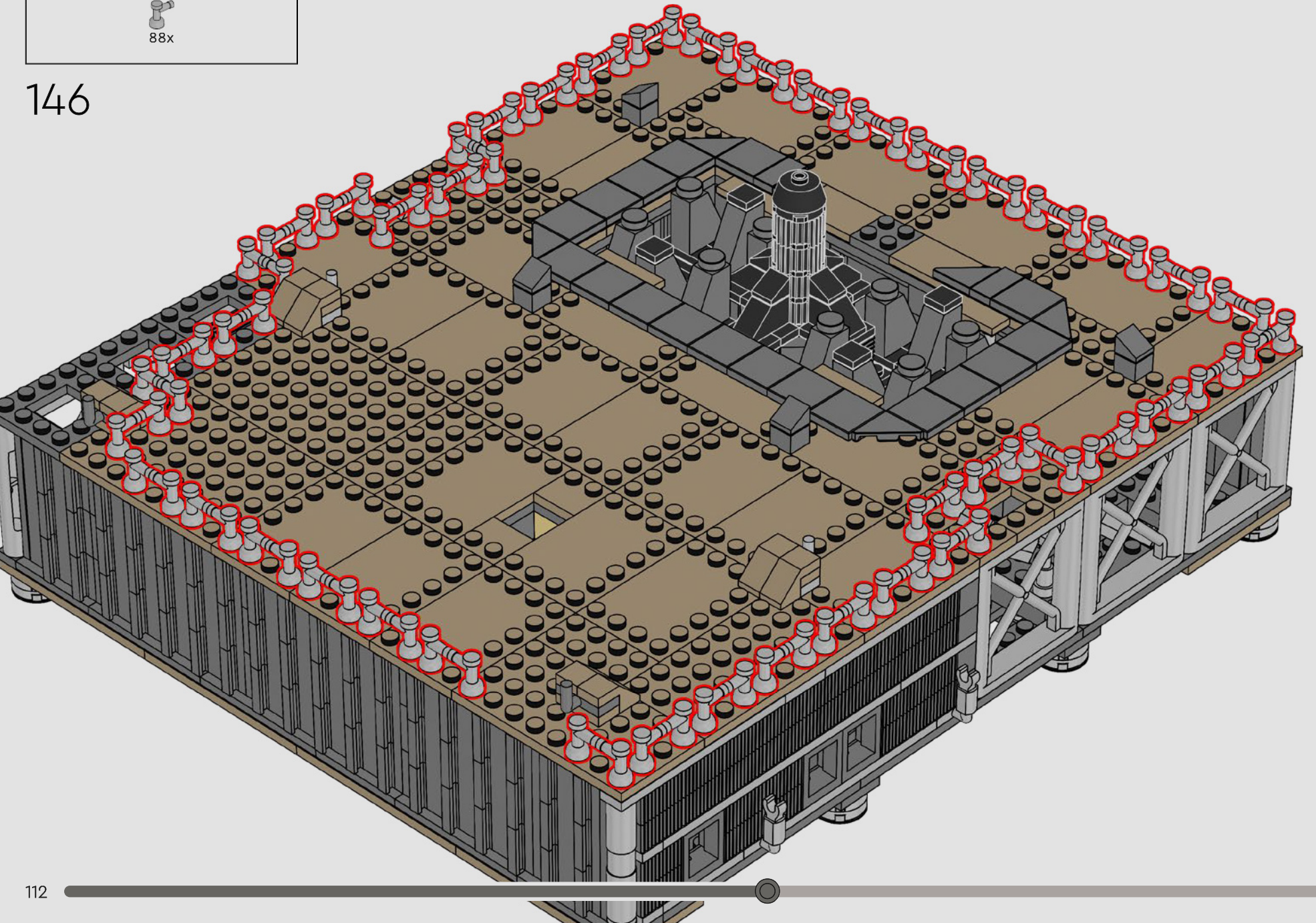



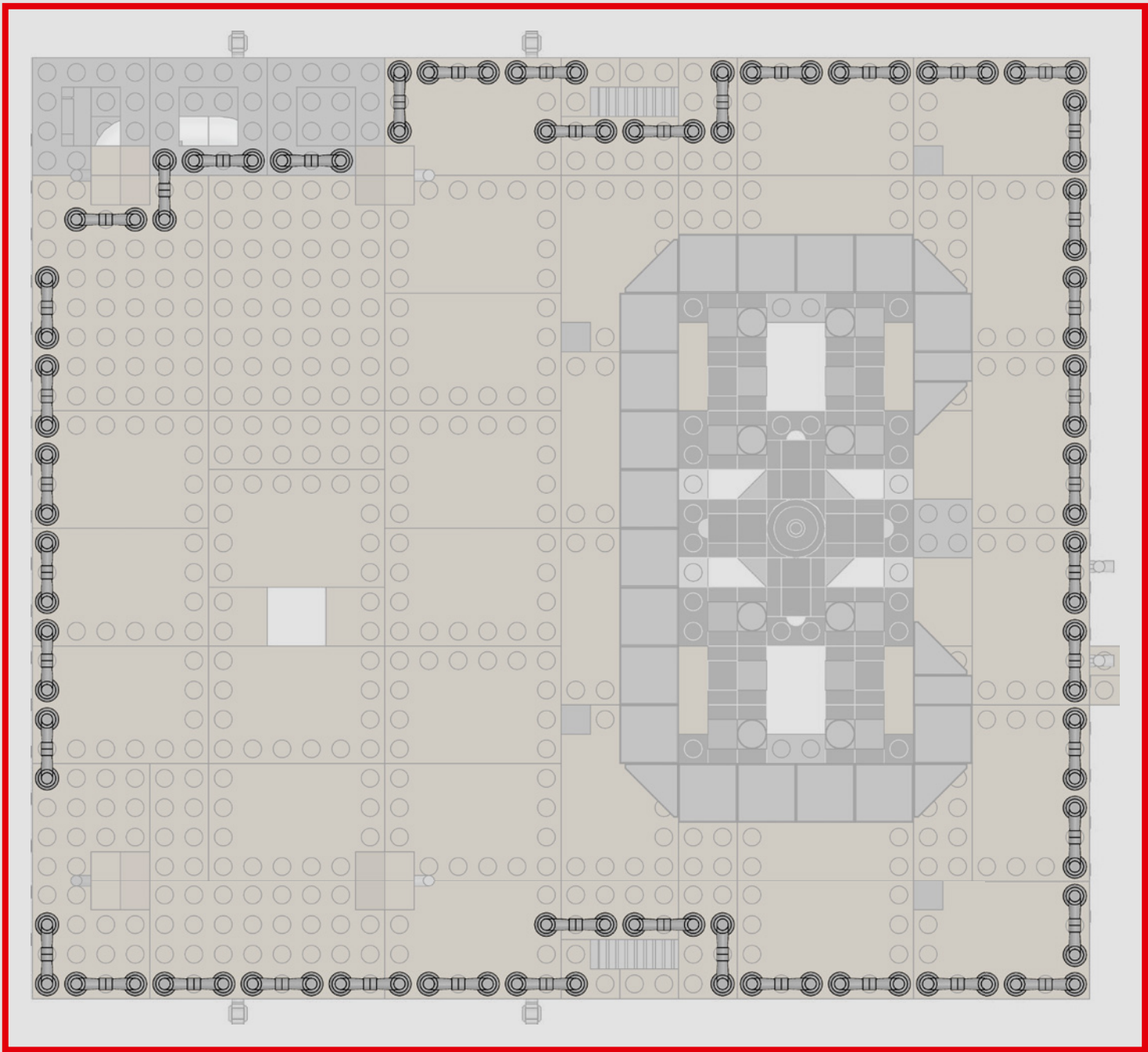

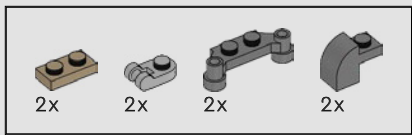

147

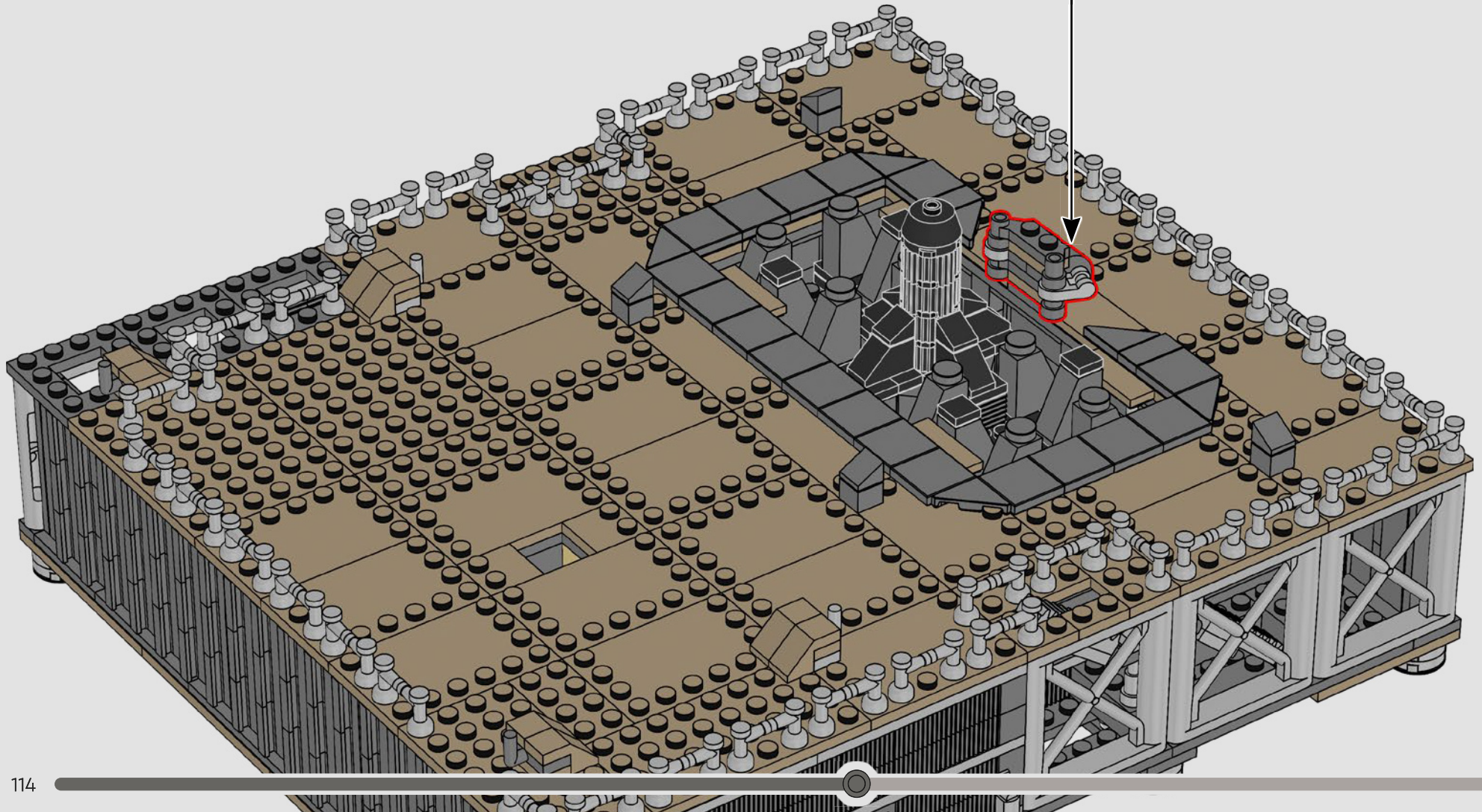
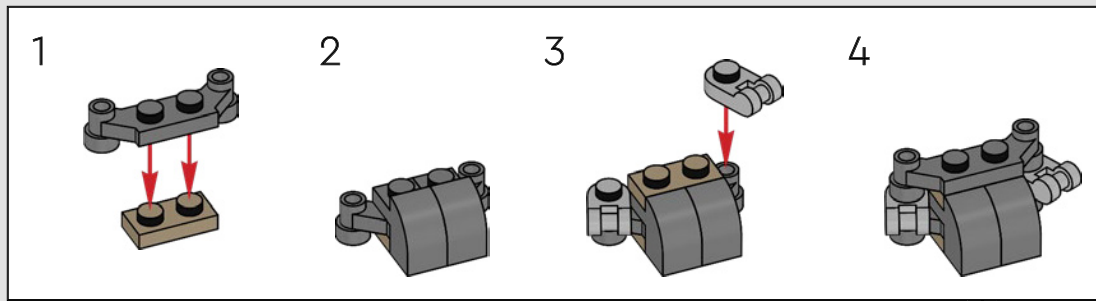

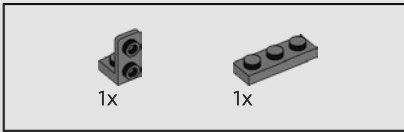
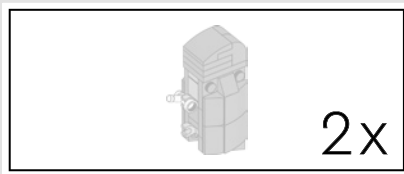

148

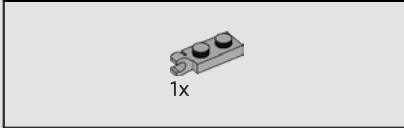
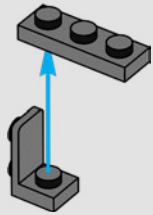

149

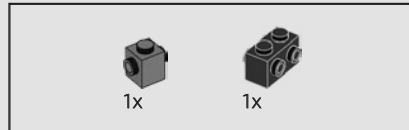
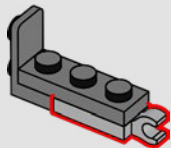

150

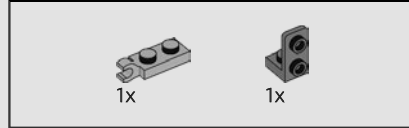
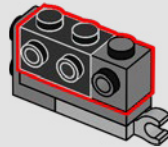

151

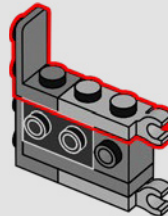

152

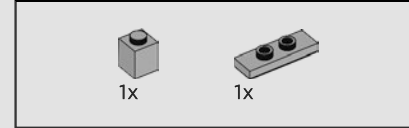
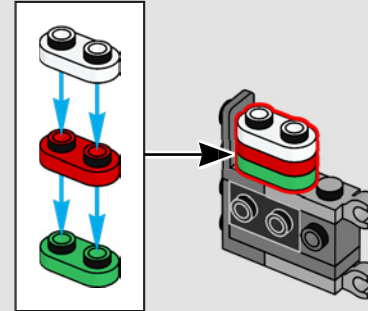

153

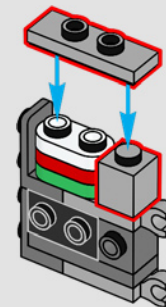

154

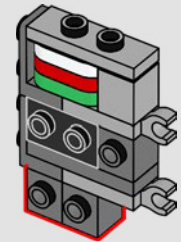

A LEGO® rocket must be powered the LEGO way, of course. The stacked rounded 1x2 plates inside the 'gas station' in front of the rocket have a long LEGO history!

Une fusée LEGO® doit bien sûr être propulsée à la manière LEGO. Les plaques rondes 1x2 empilées à l'intérieur de la « station de carburant » à l'avant de la fusée ont une longue histoire au sein de LEGO !

Un cohete LEGO® debe propulsarse a la manera de LEGO, por supuesto. ¡Las placas 1x2 redondeadas del interior de la *gasolinera* que se ubica frente al cohete tienen una larga historia en LEGO!

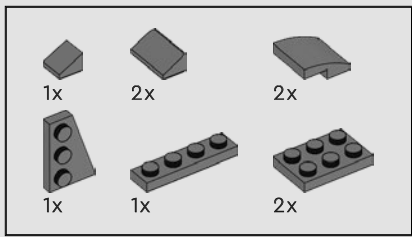

155

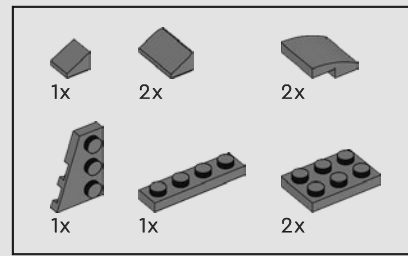
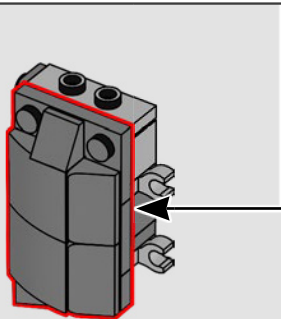
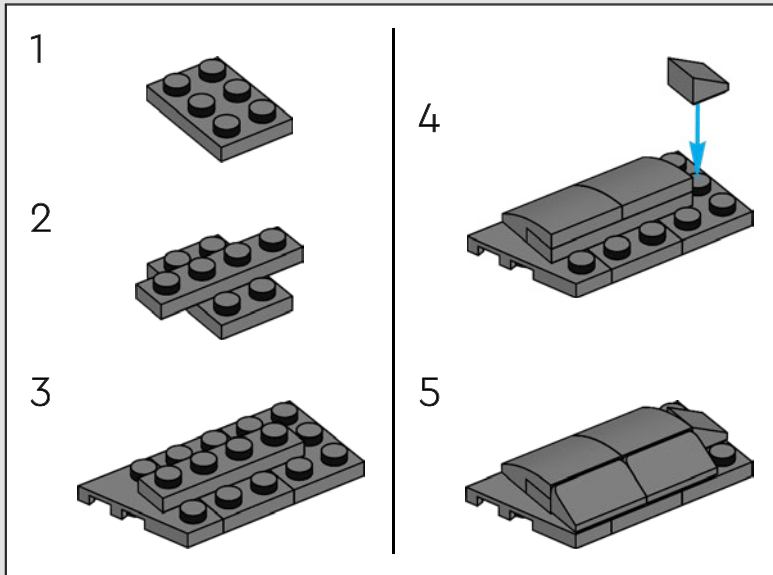

156

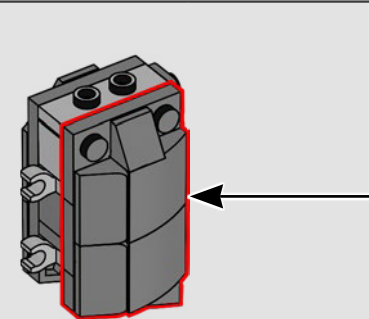
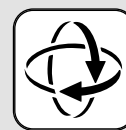
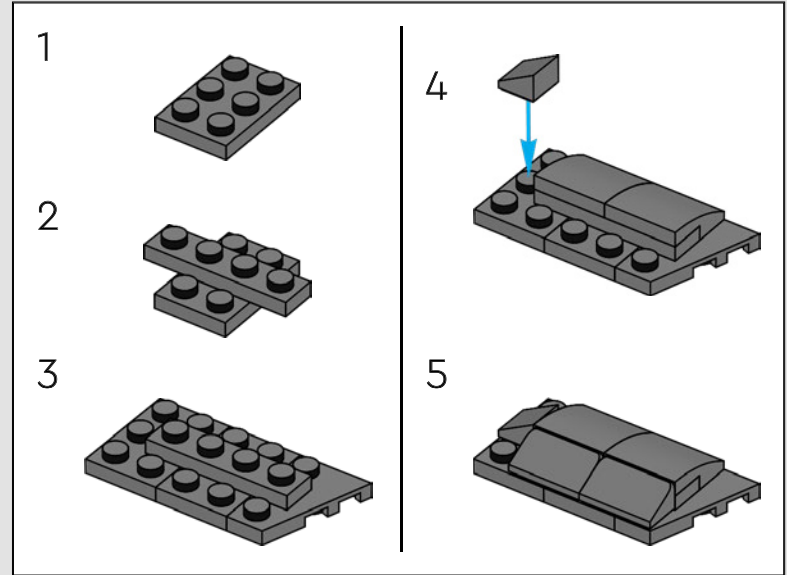

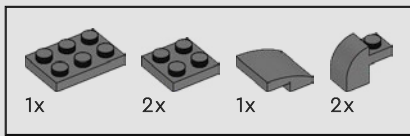

157

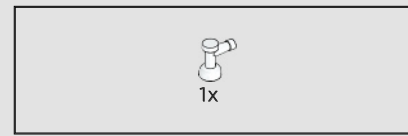
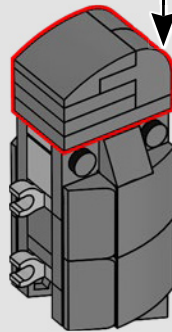
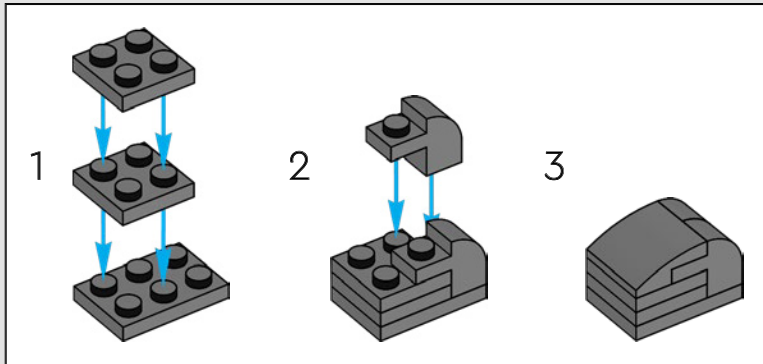

158

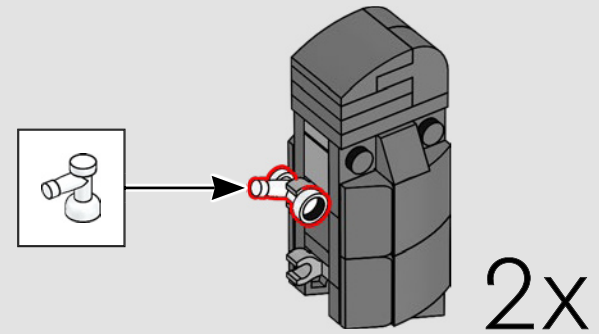

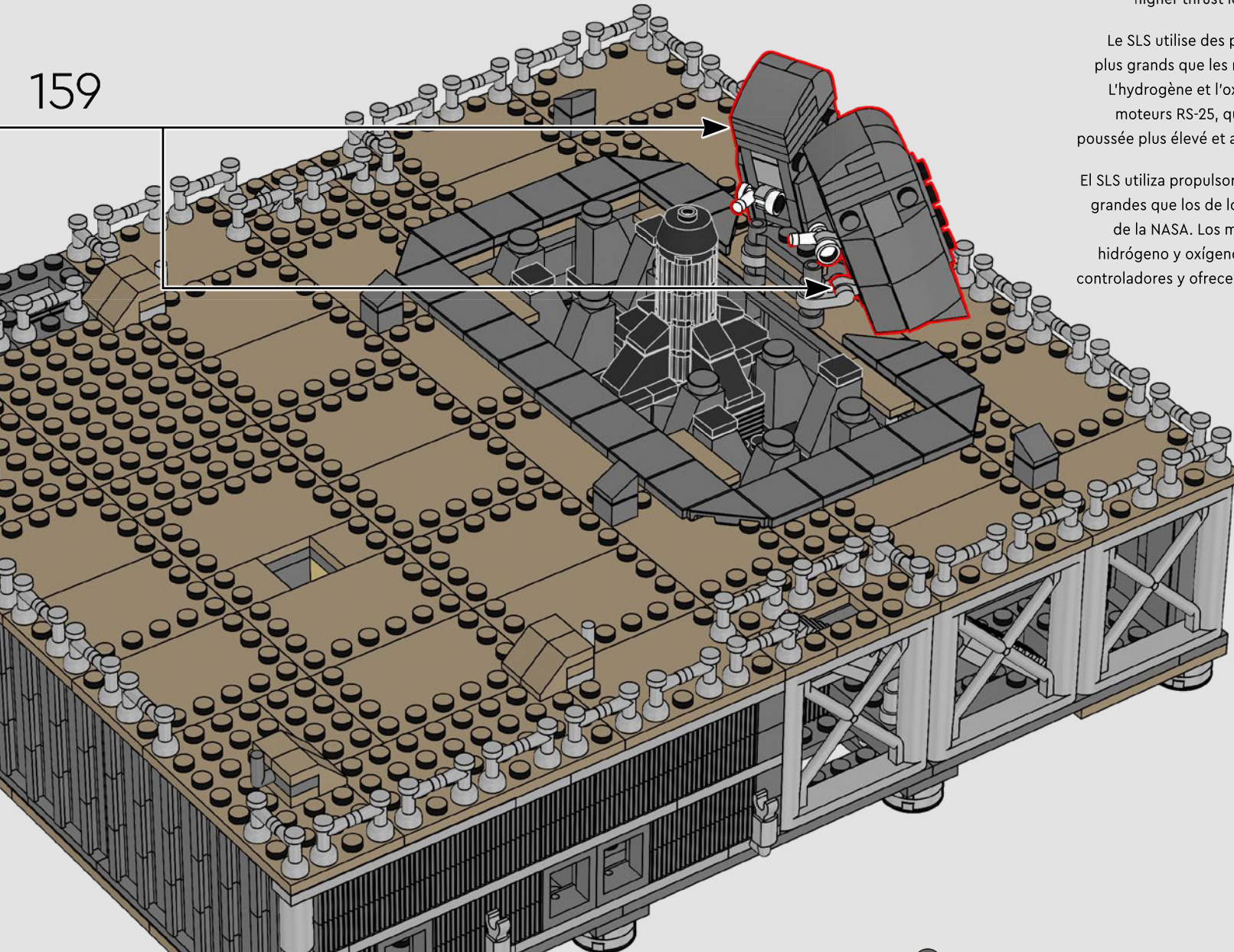

The SLS uses larger solid rocket boosters than the NASA space shuttles. Liquid hydrogen and liquid oxygen feed the RS-25 engines, which operate at a higher thrust level and with new controllers.

Le SLS utilise des propulseurs à propergol solide plus grands que les navettes spatiales de la NASA. L'hydrogène et l'oxygène liquides alimentent les moteurs RS-25, qui fonctionnent à un niveau de poussée plus élevé et avec de nouveaux contrôleurs.

El SLS utiliza propulsores de combustible sólido más grandes que los de los transbordadores espaciales de la NASA. Los motores RS-25 alimentados por hidrógeno y oxígeno líquidos cuentan con nuevos controladores y ofrecen un nivel de empuje superior.

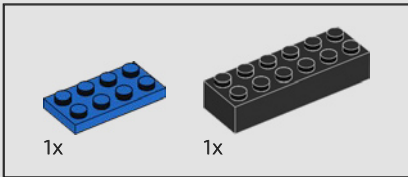
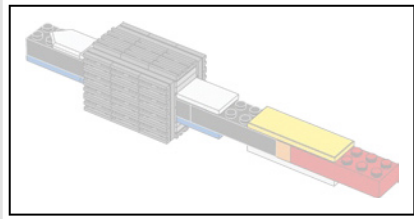

160

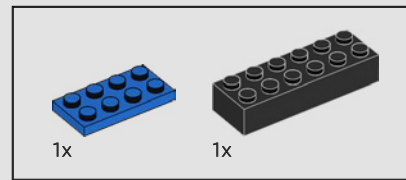
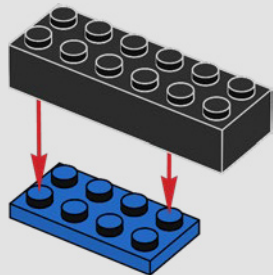

161

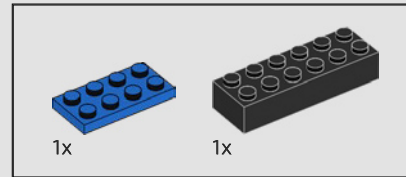
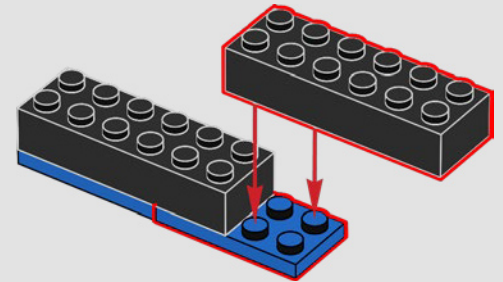

162

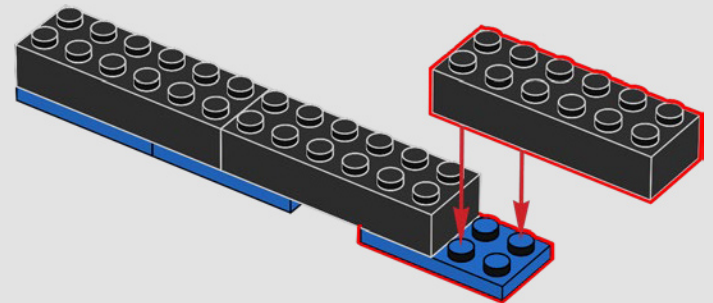

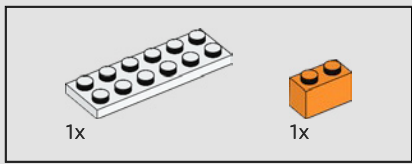

163

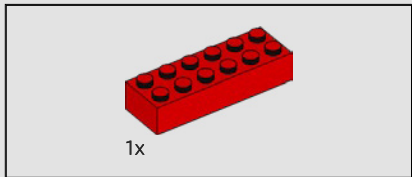
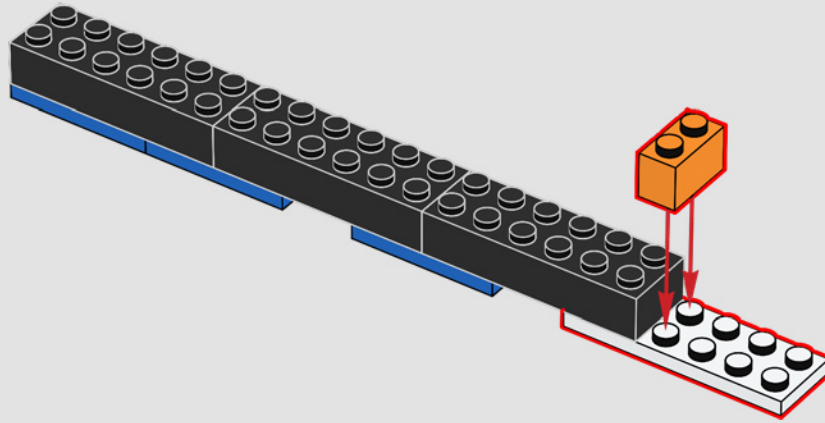

164

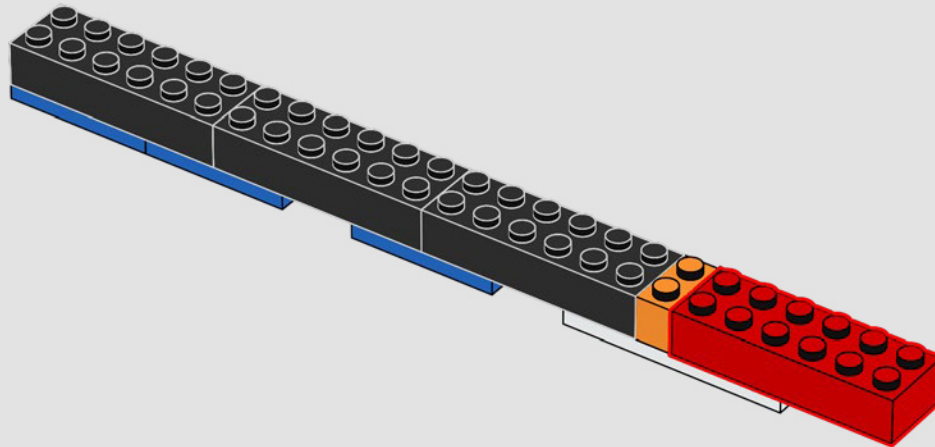



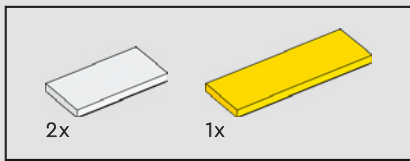

165

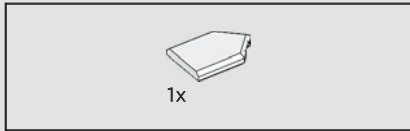
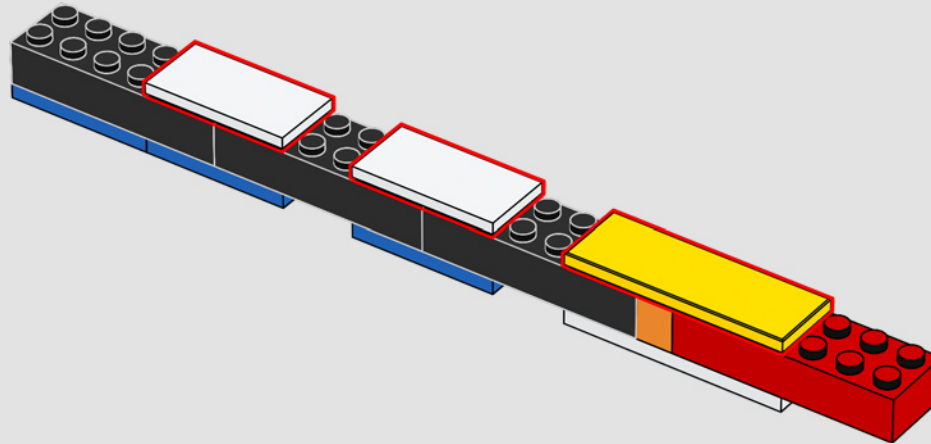

166

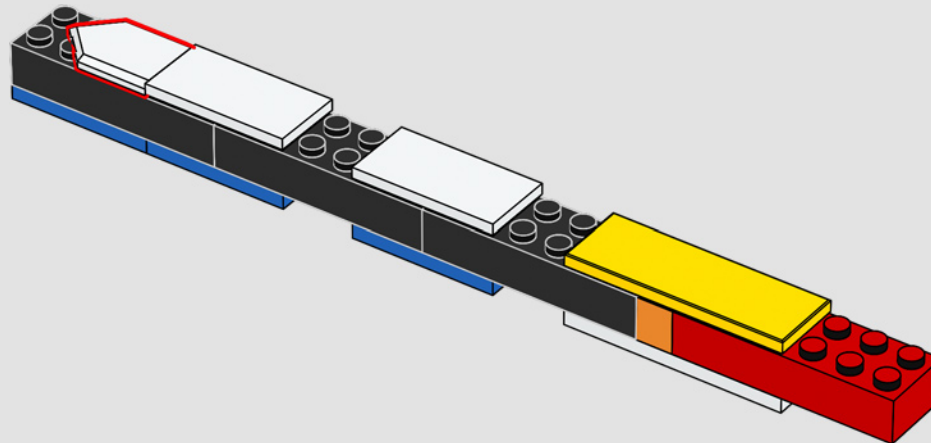

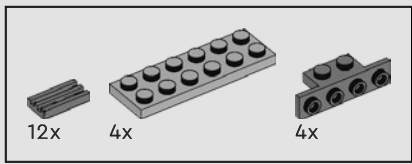

167

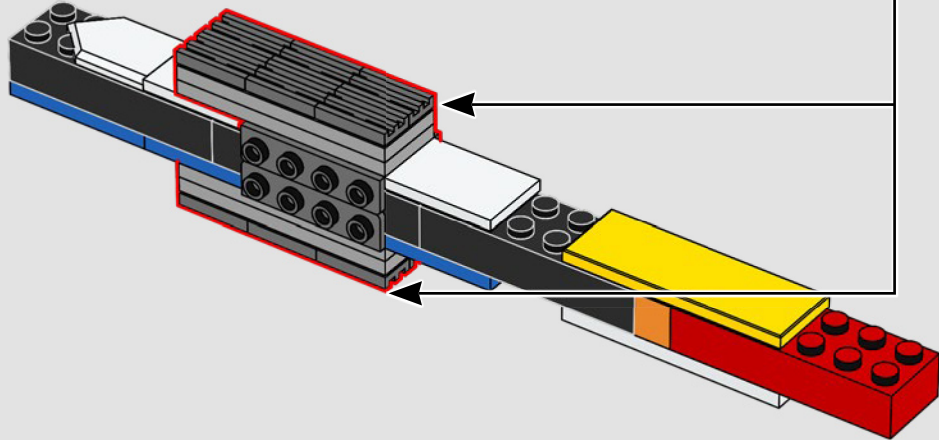
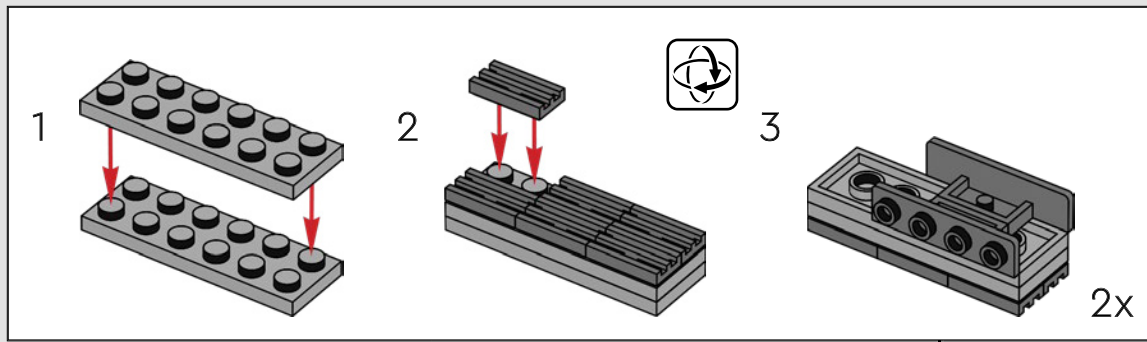

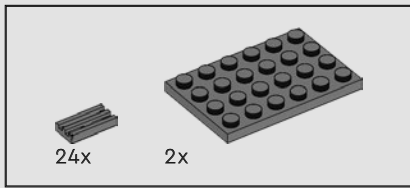

168

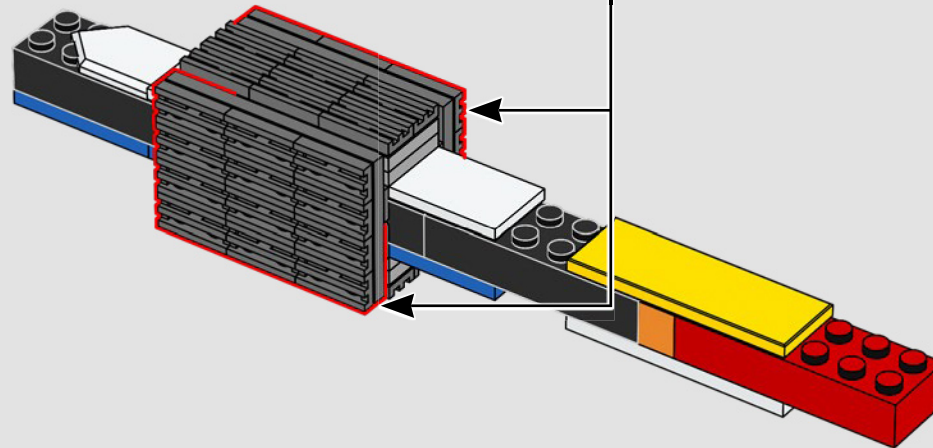
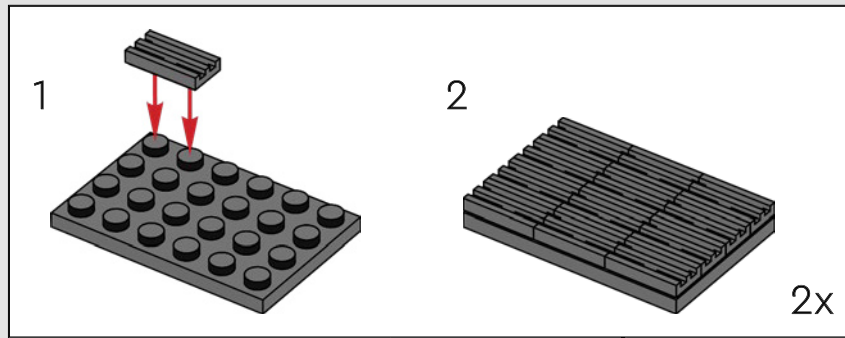

169

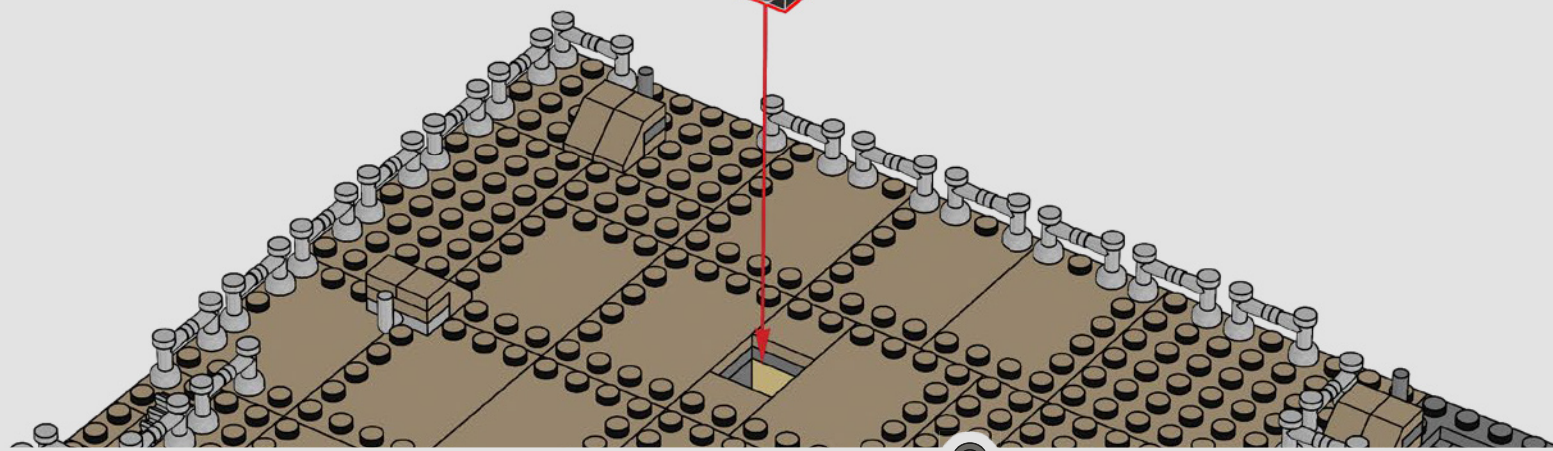
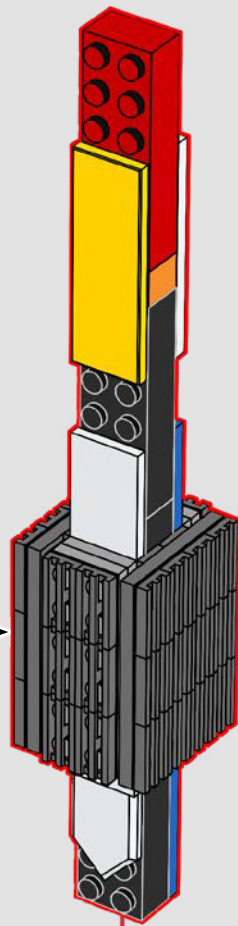

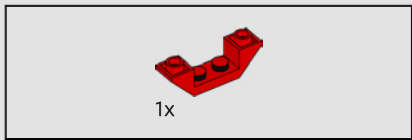

170

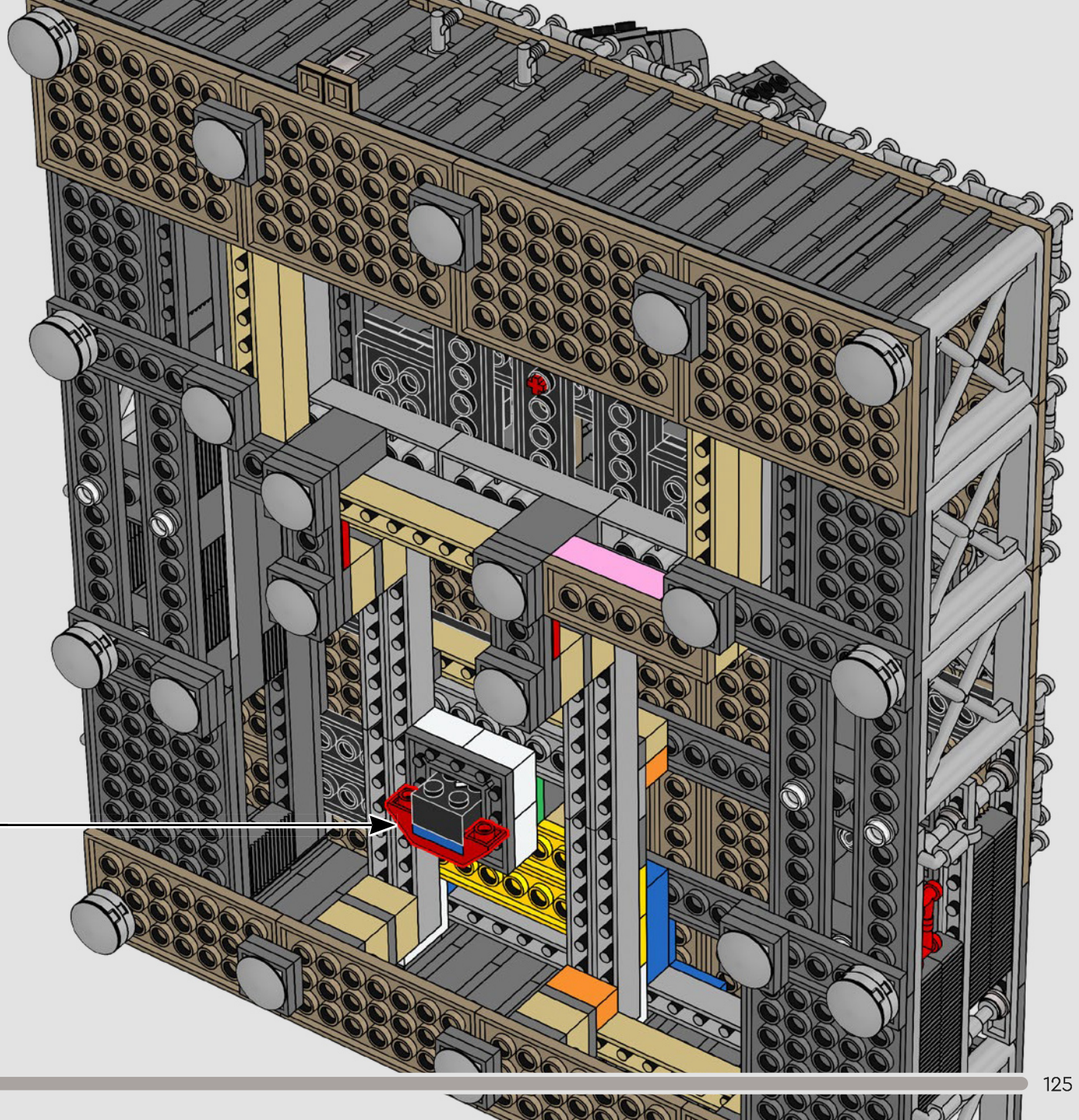
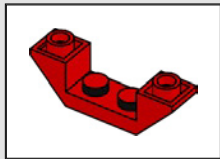



171

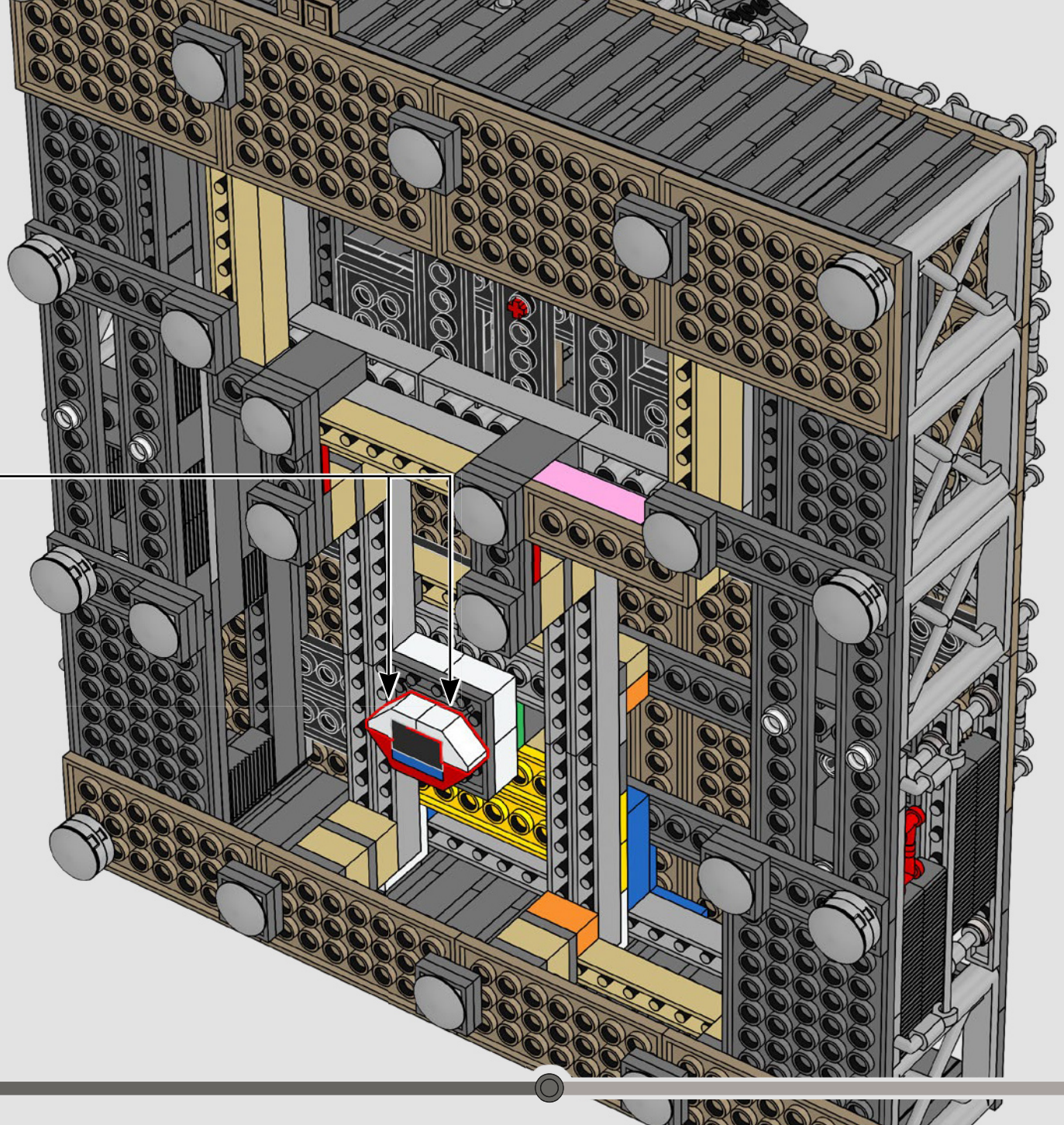
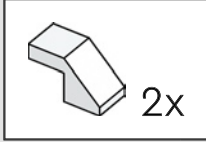

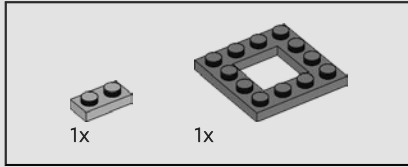
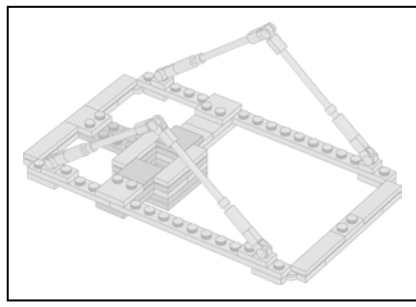

172

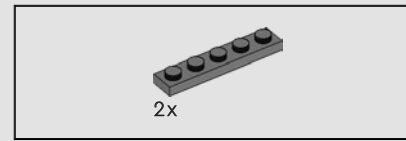
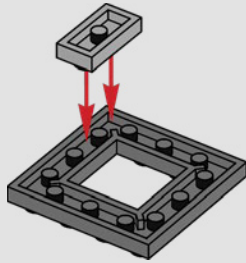

173

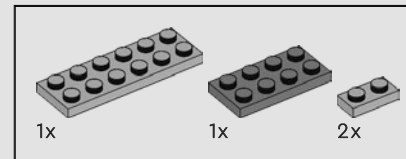
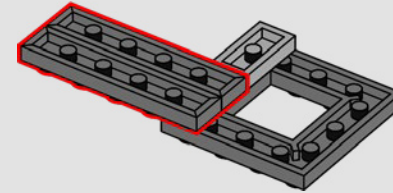

174

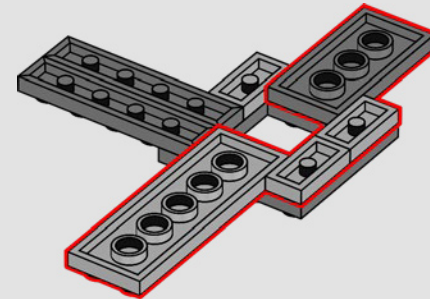

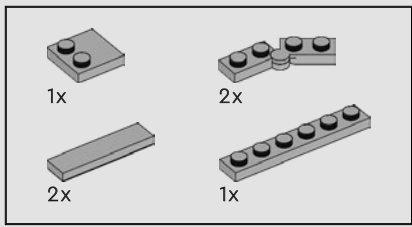

175

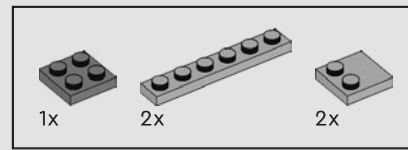
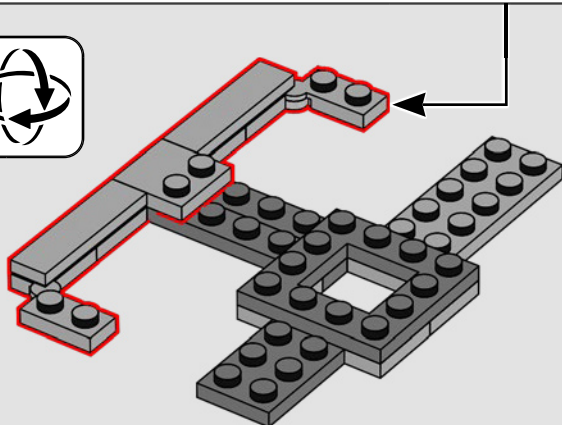
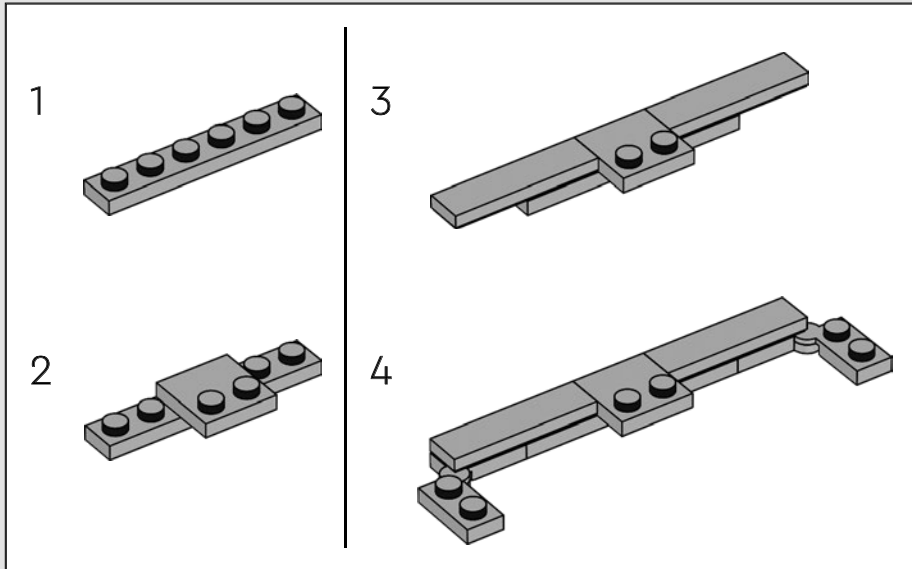

176

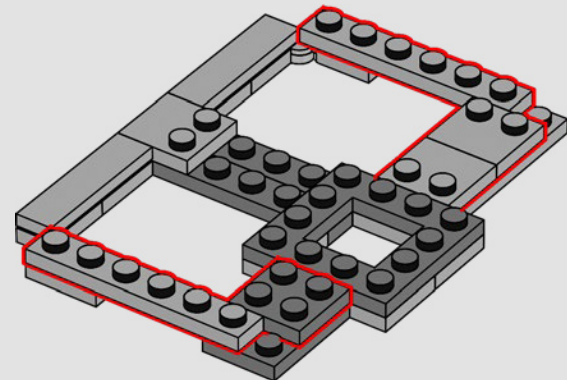



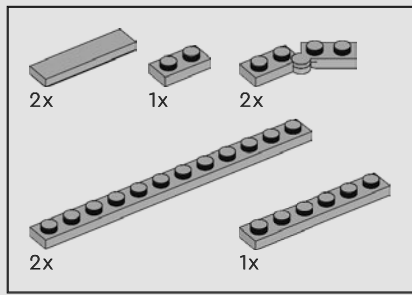

177

1

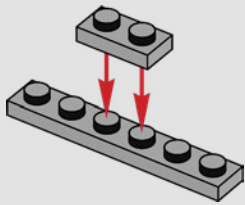

2

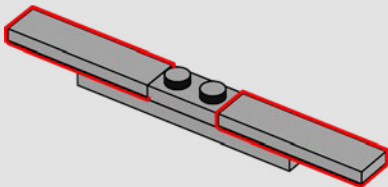

3

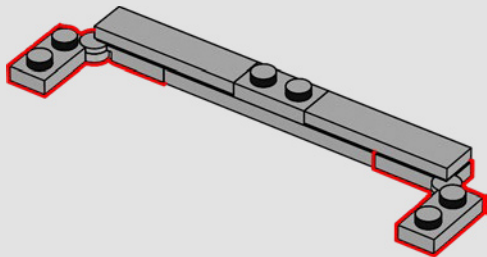

4

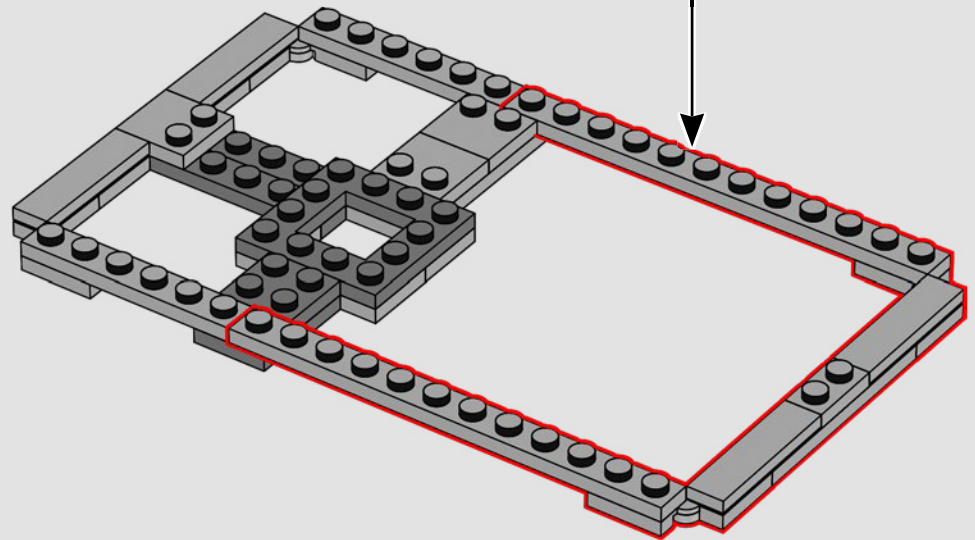
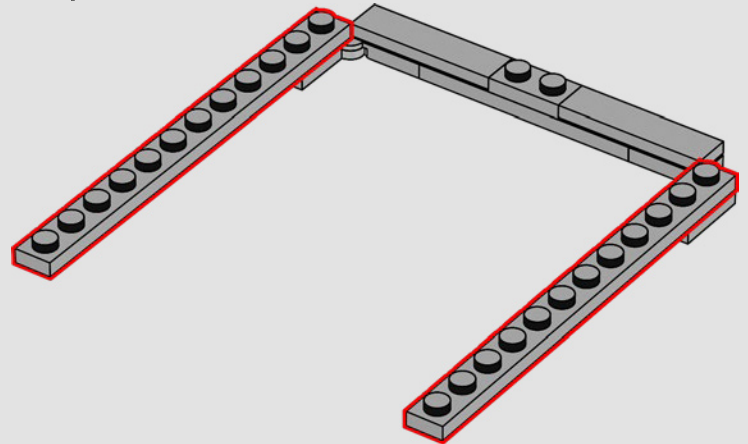

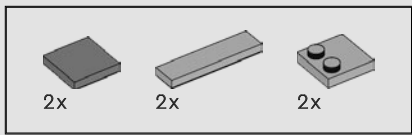

178

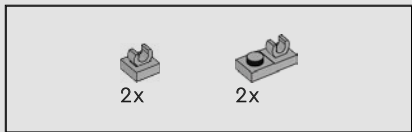
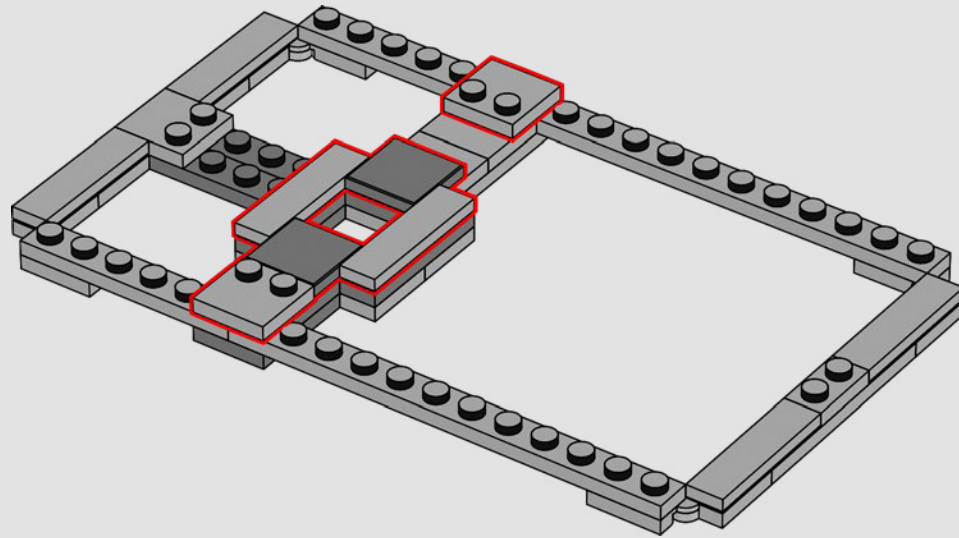

179

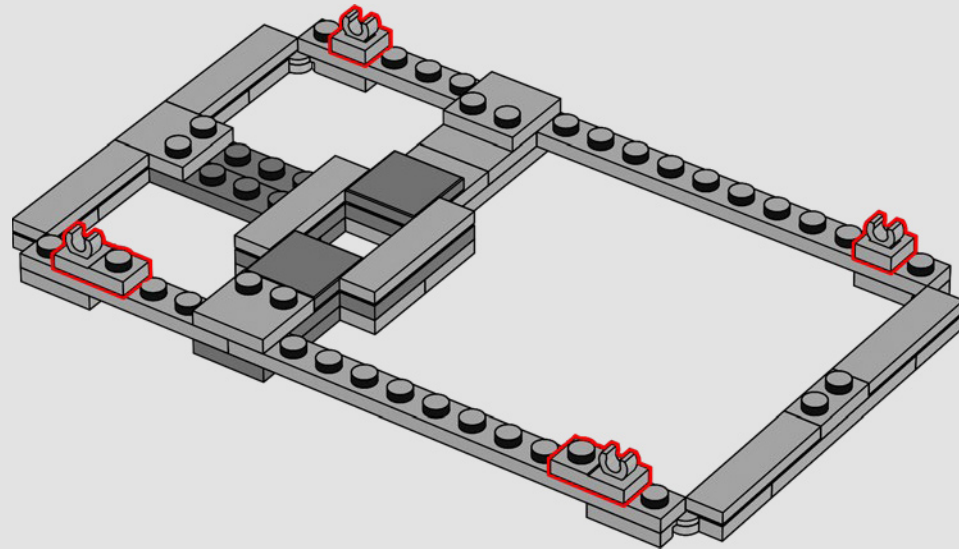

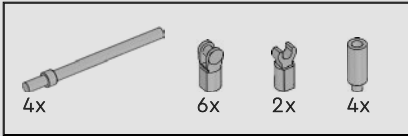
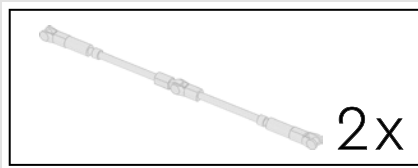

180

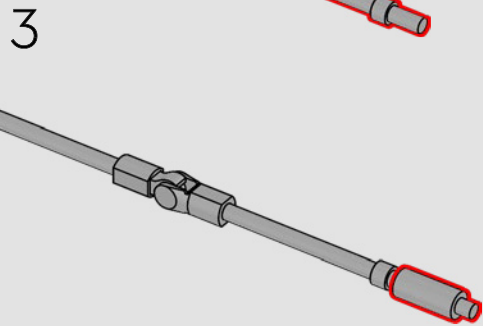
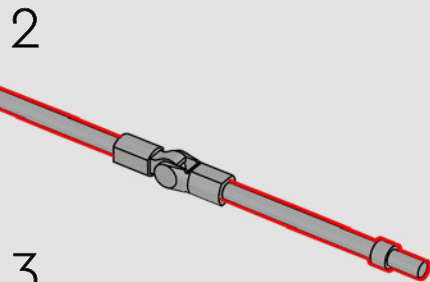
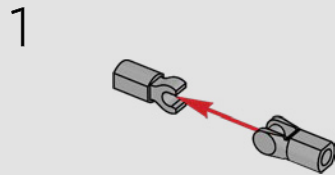

4

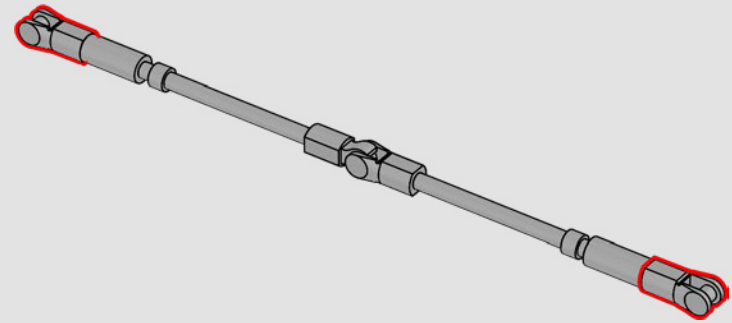

2x

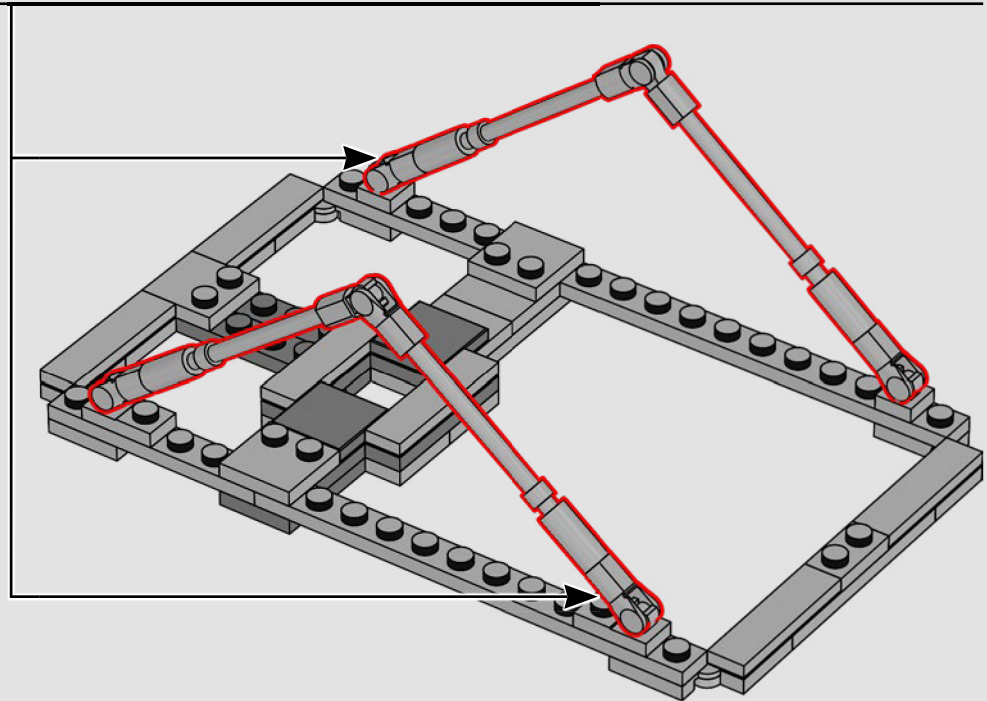

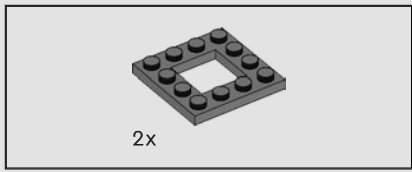

181

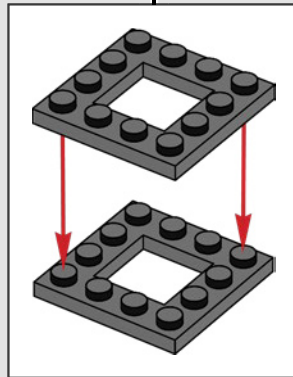
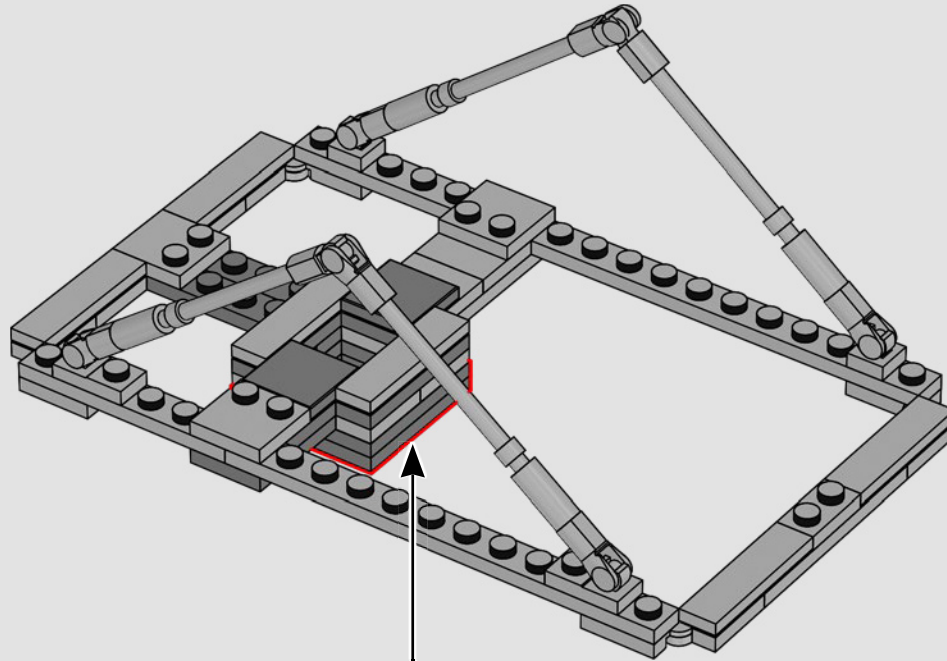

182

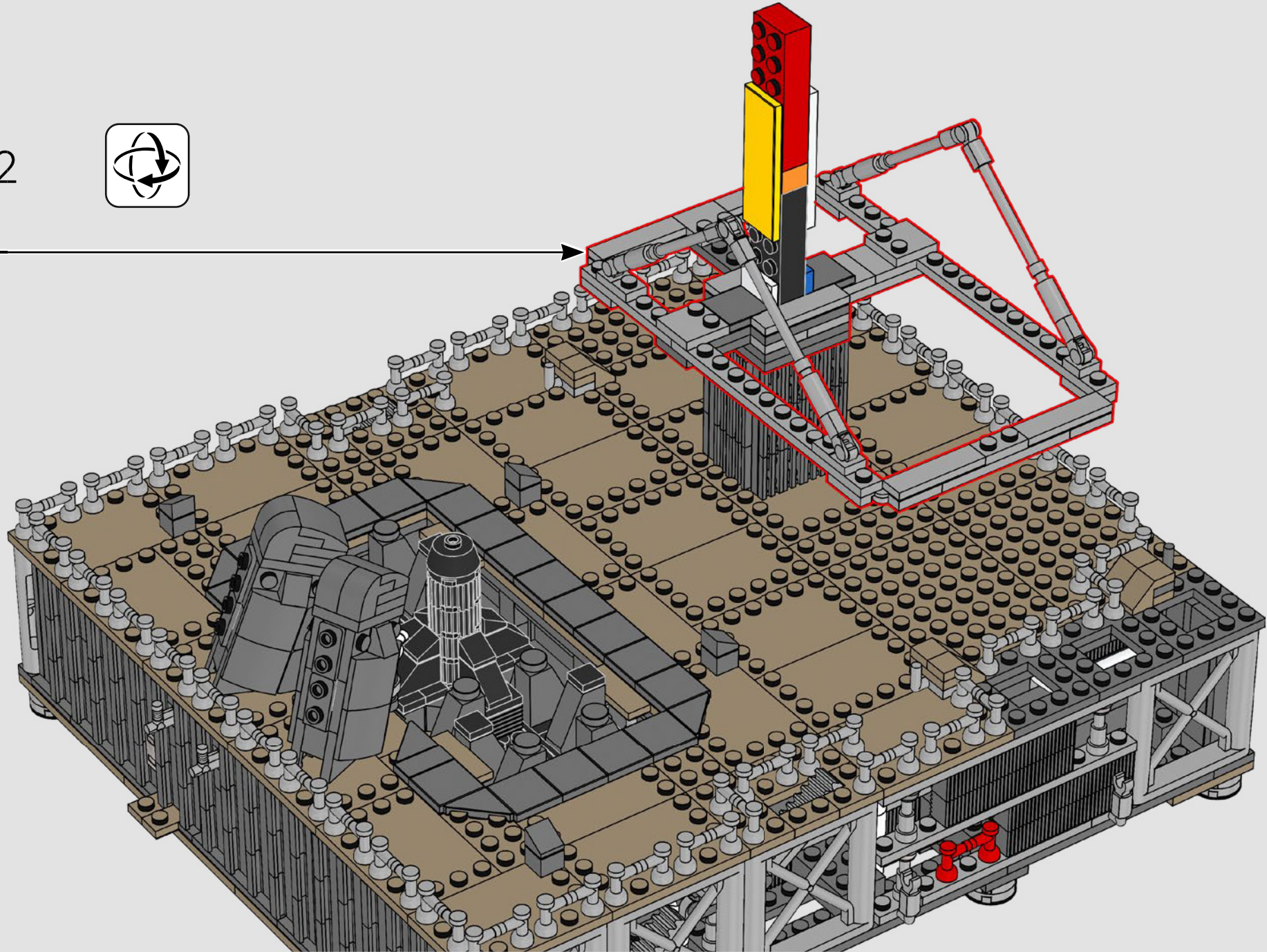

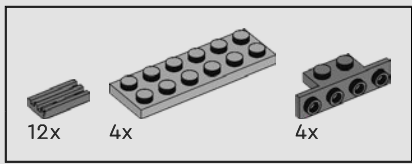

183

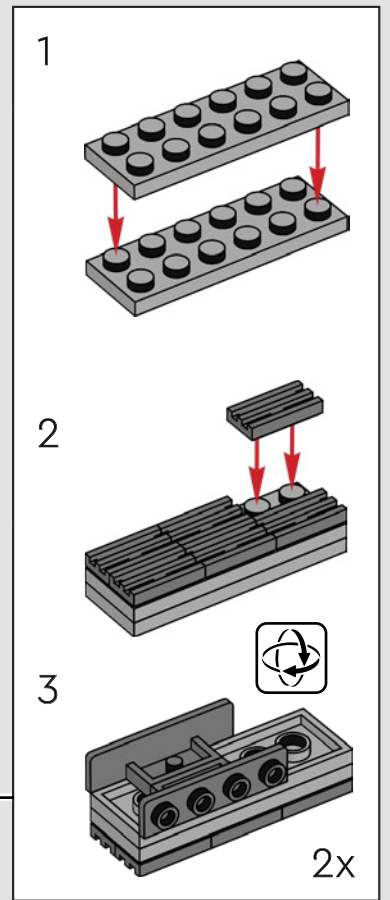
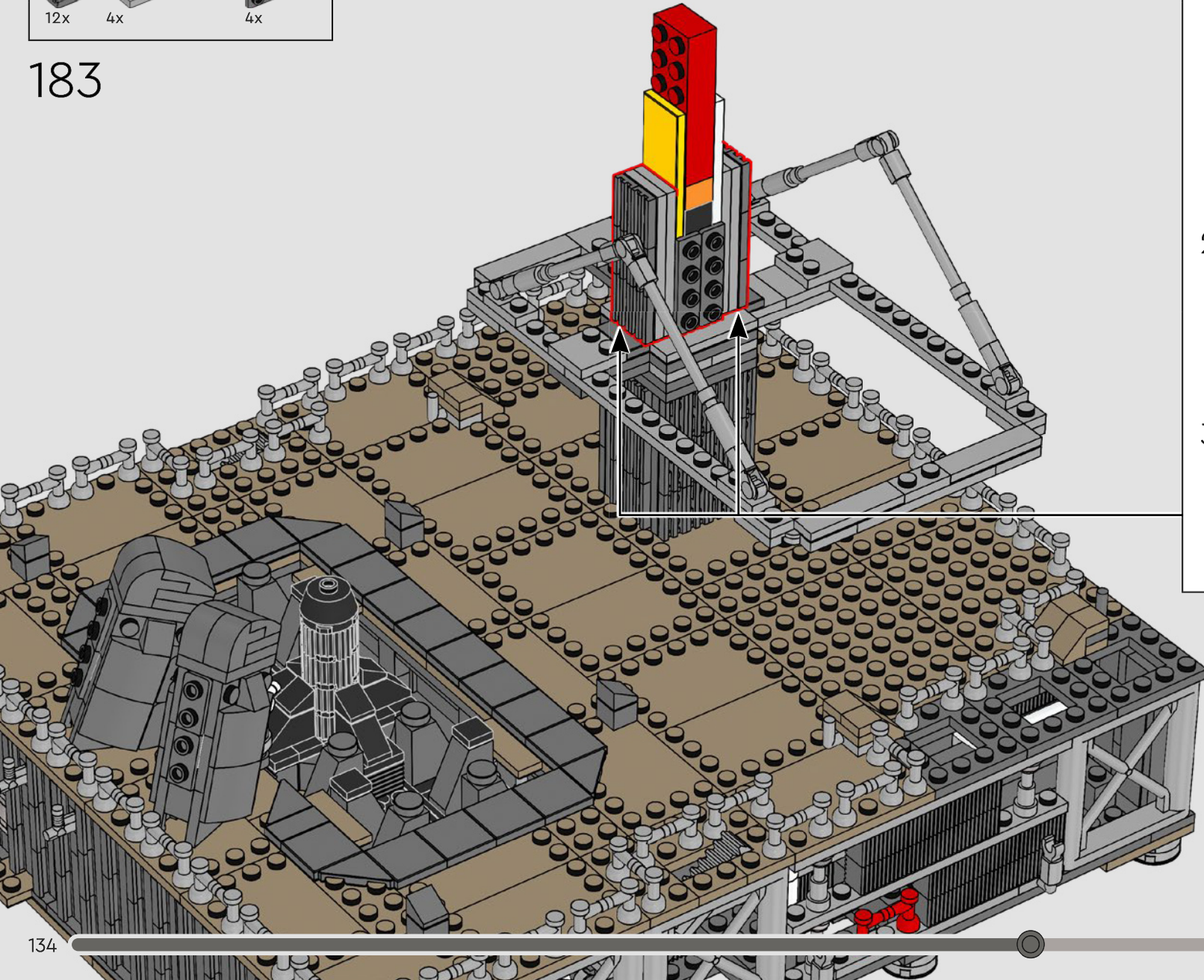

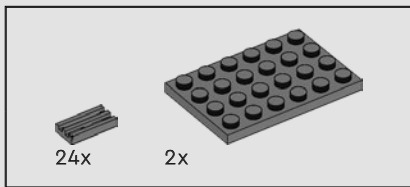

184

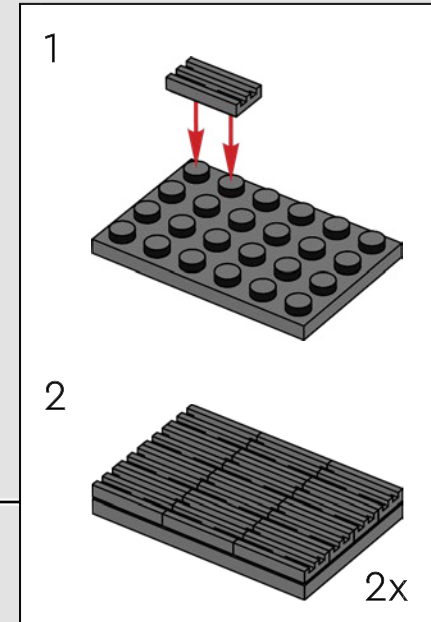
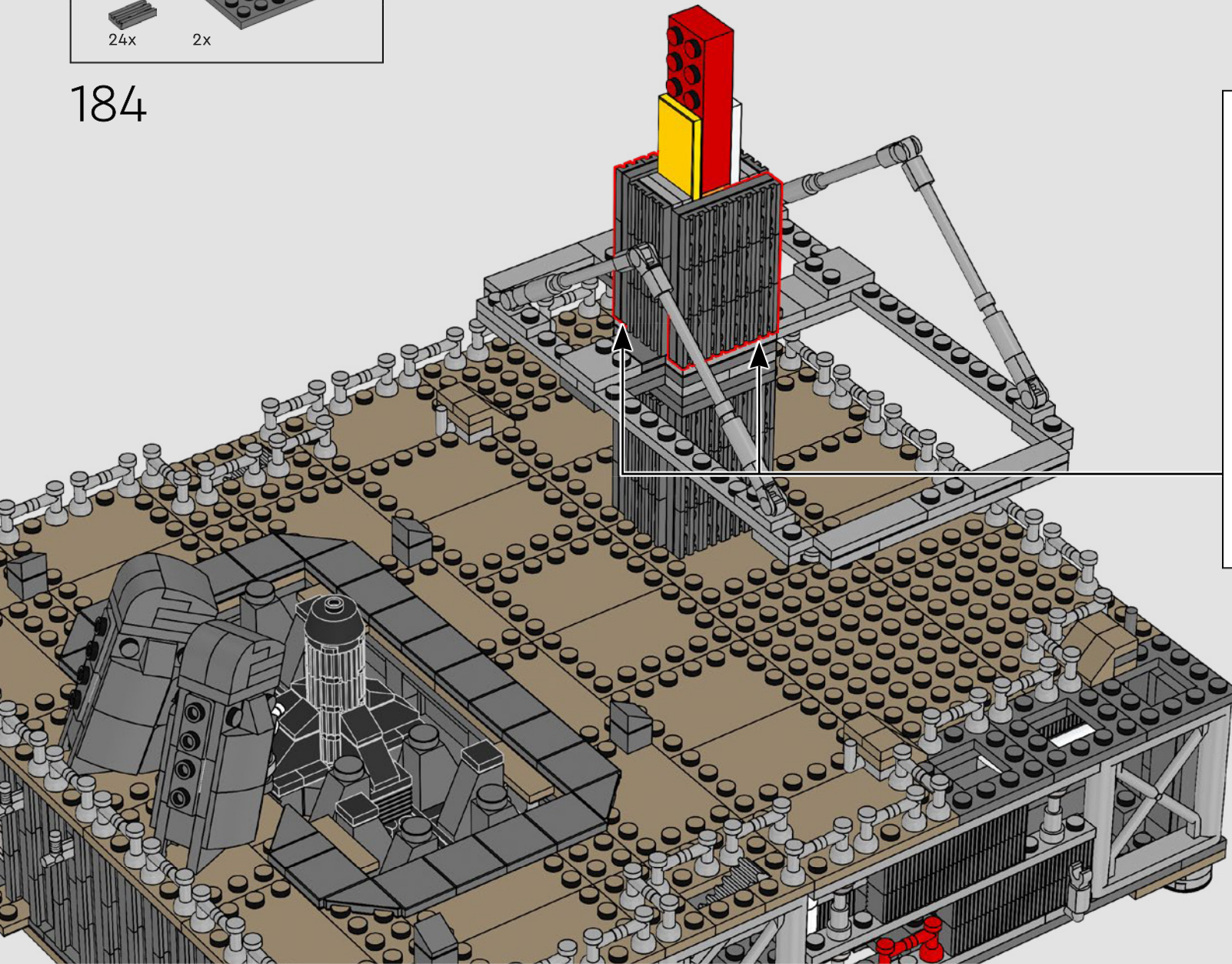

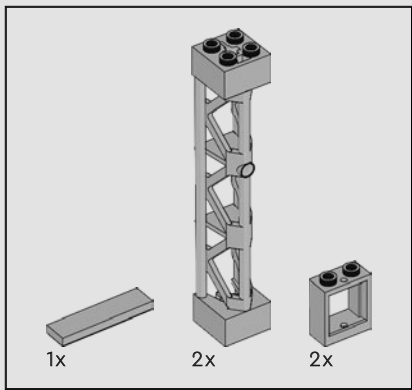

185

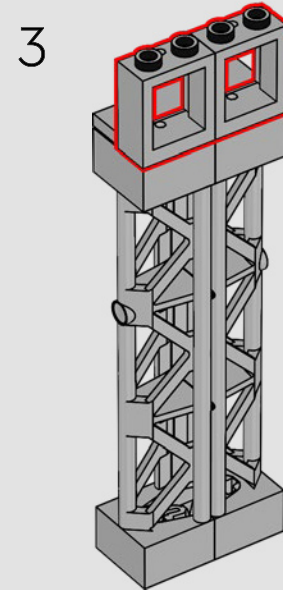
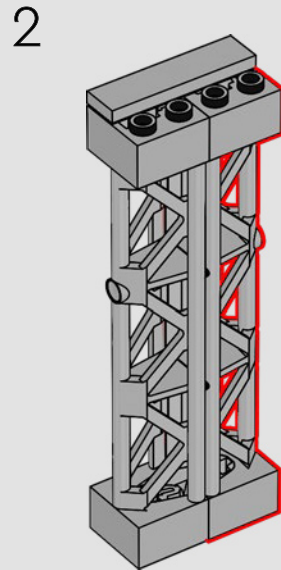
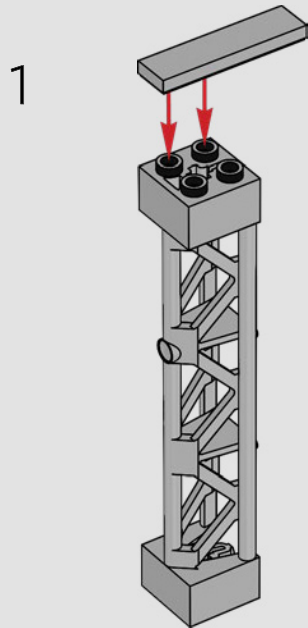



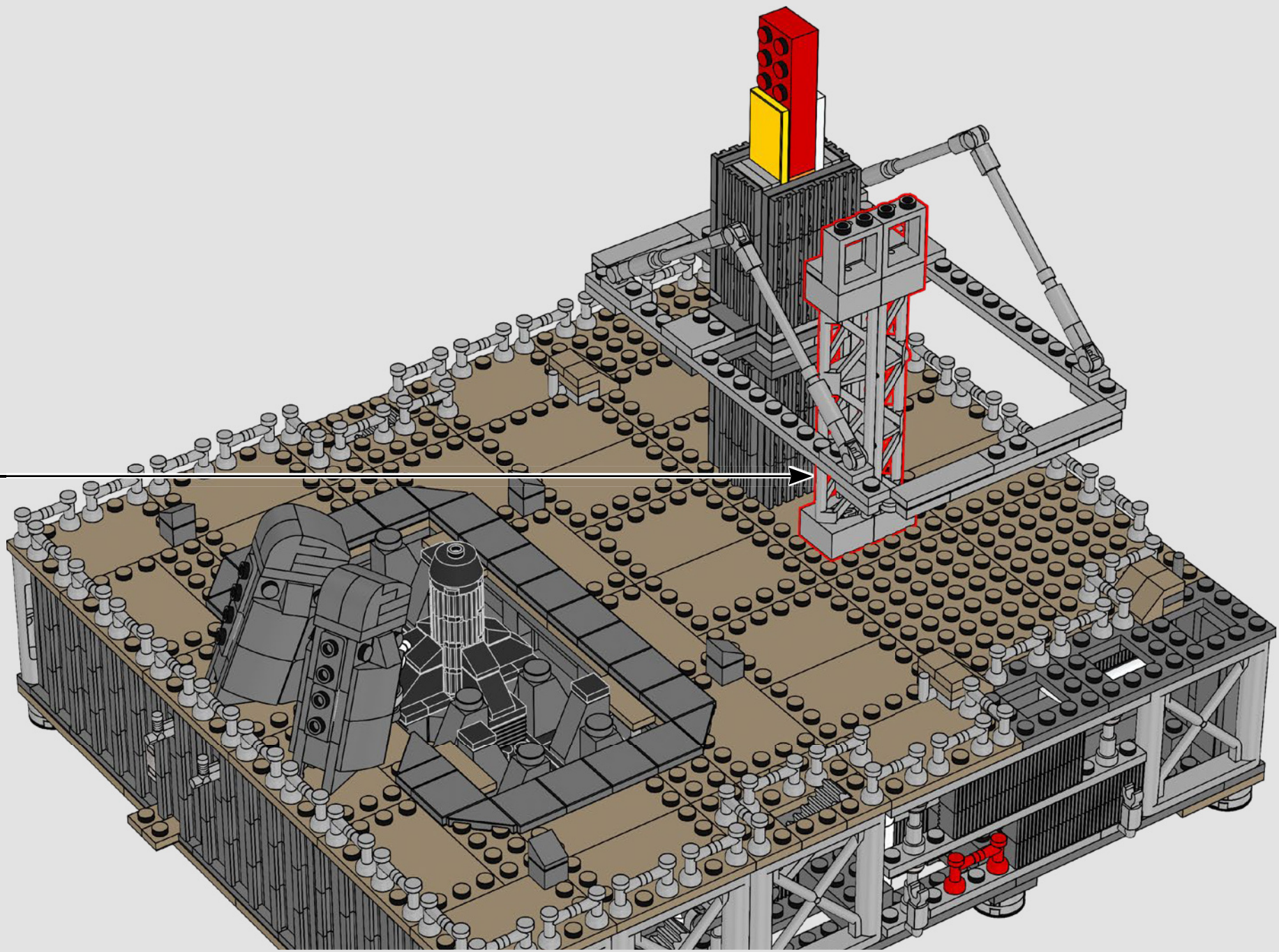

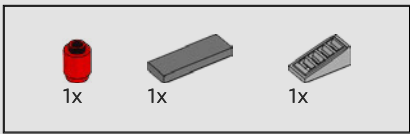

186

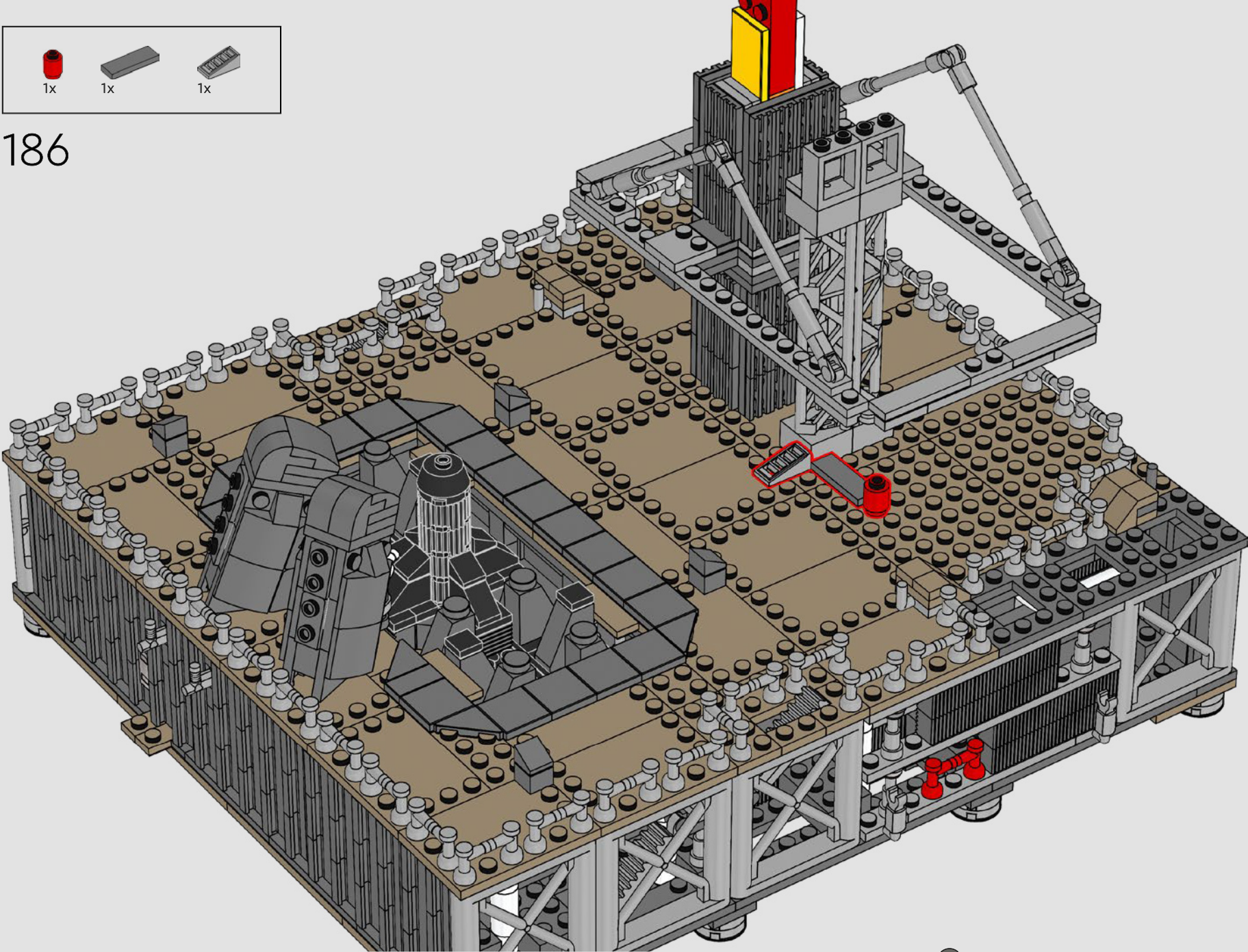

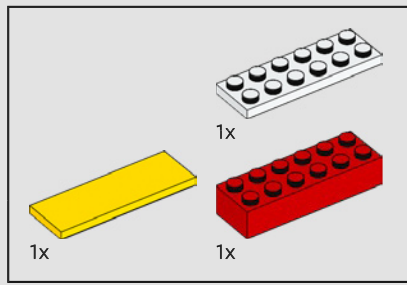

187

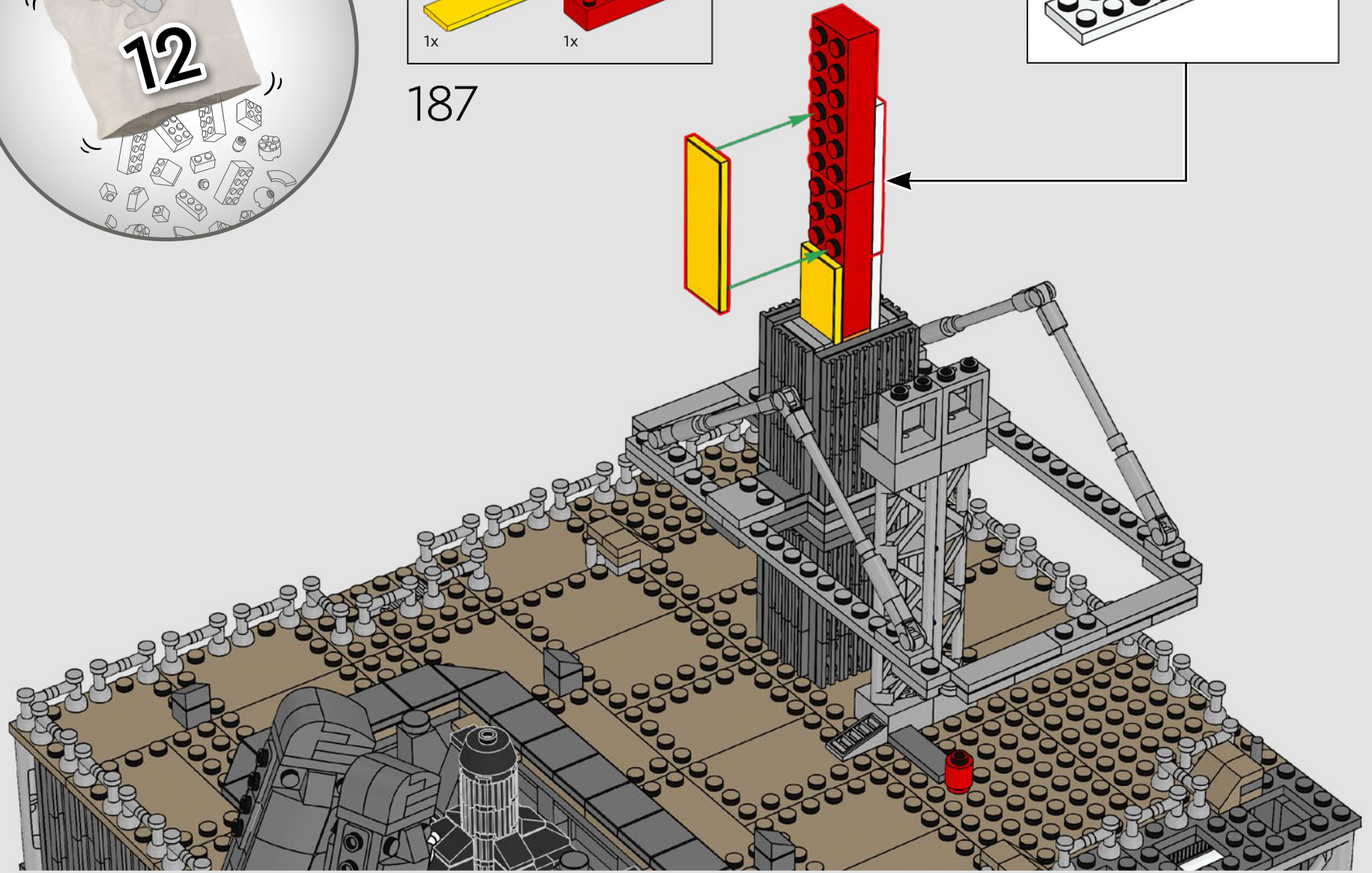
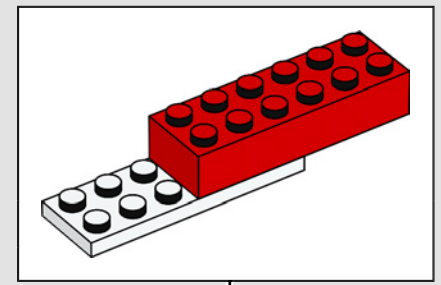

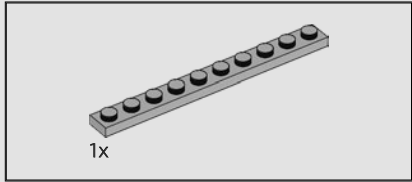
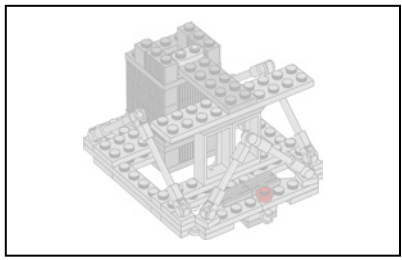

188

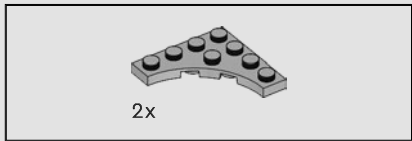
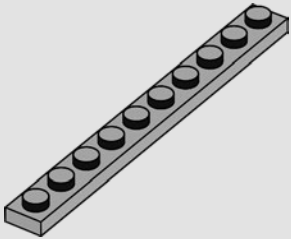

189

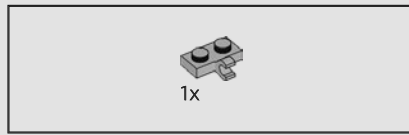
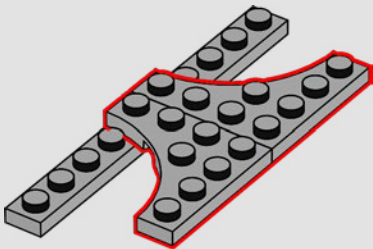

190

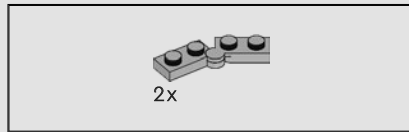
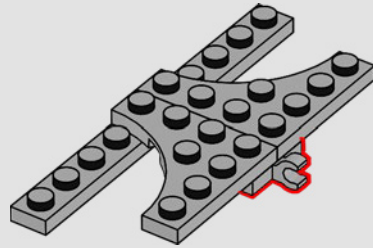

191

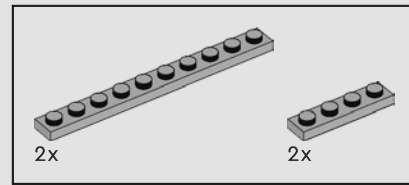
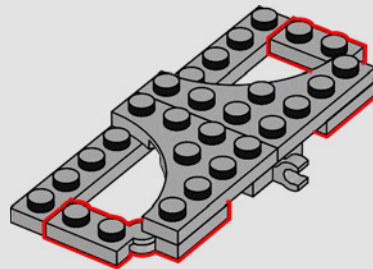

192

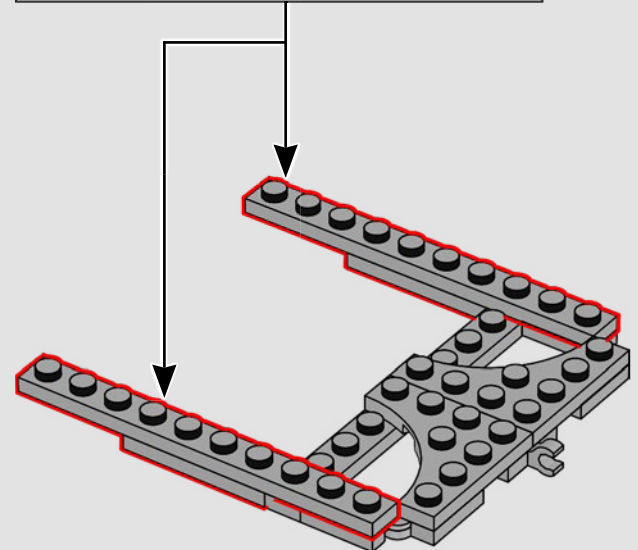
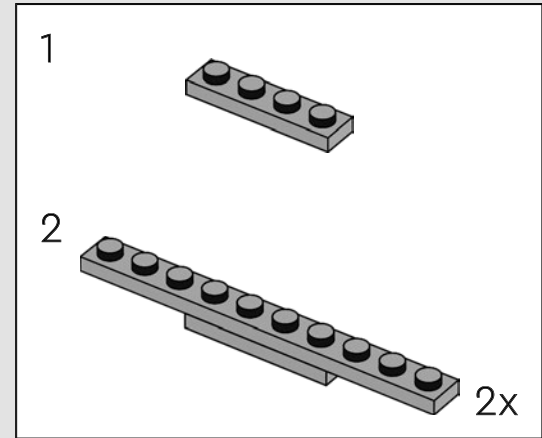

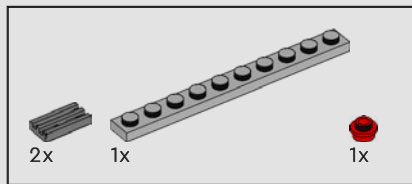

193

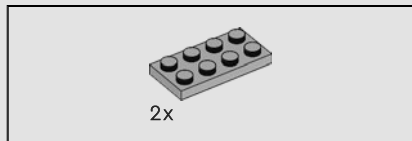
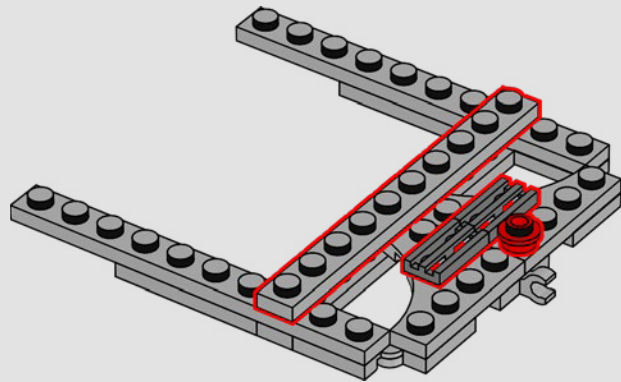

194

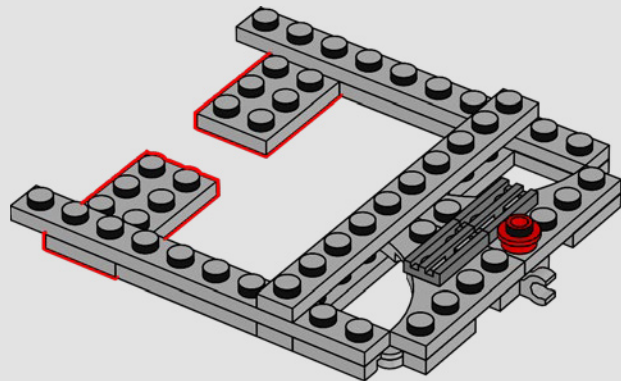

195

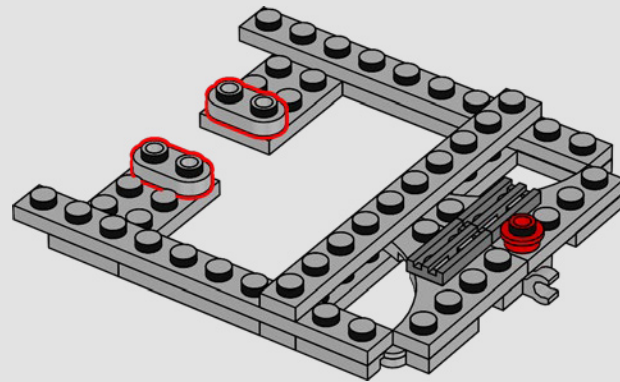

196

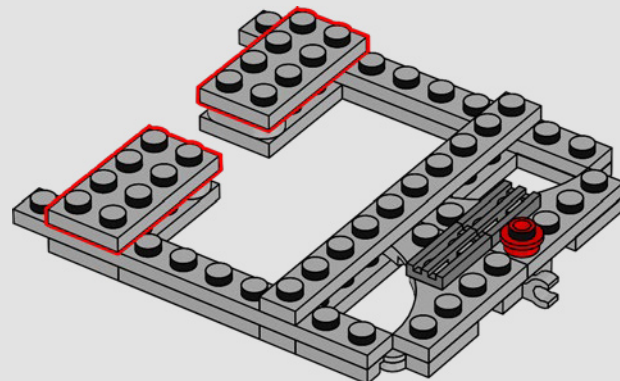

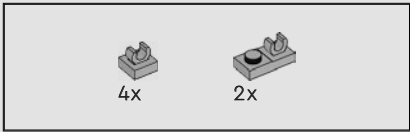

197

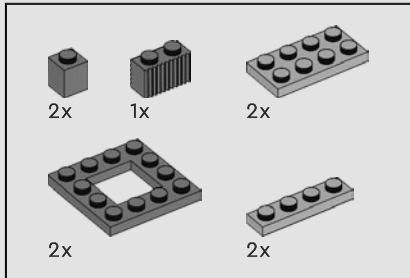
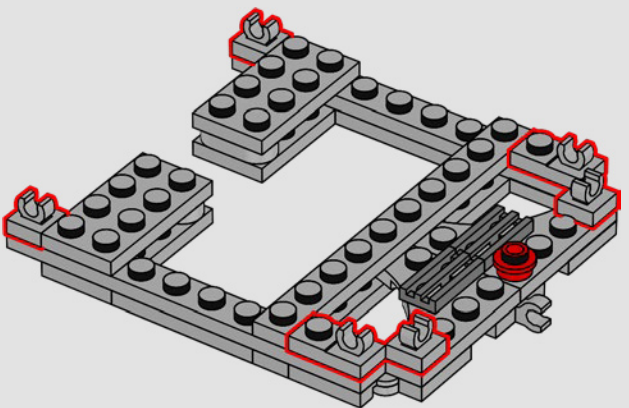

198

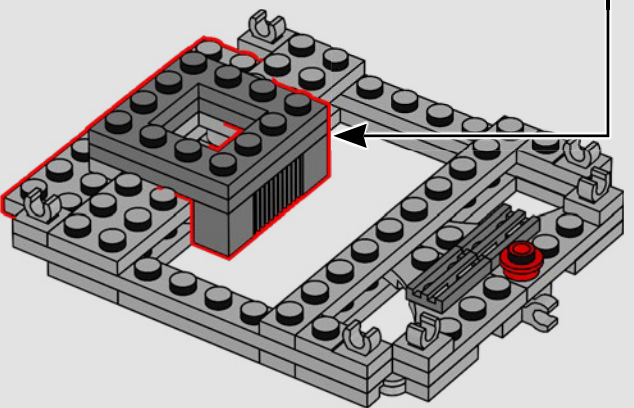
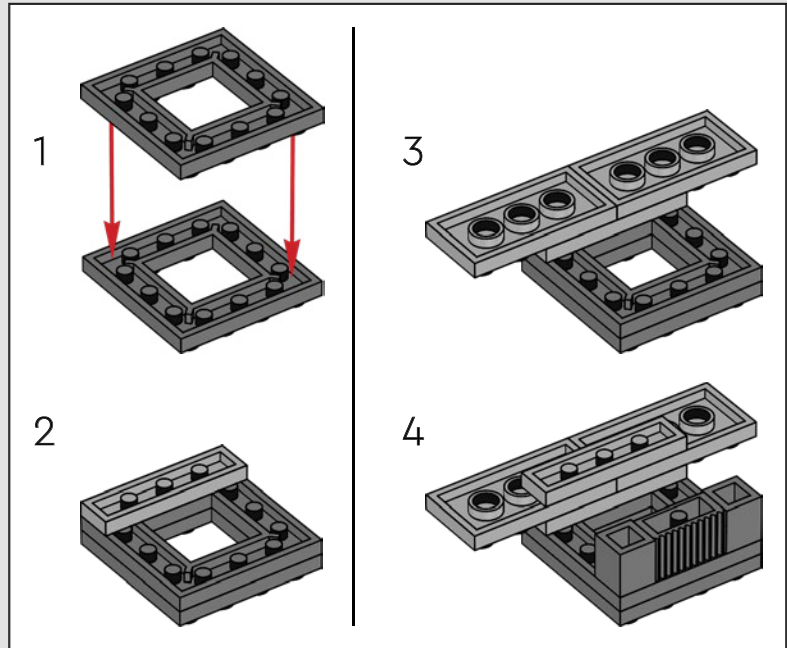

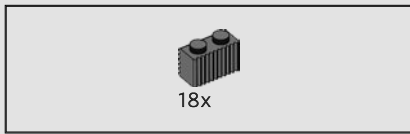

199

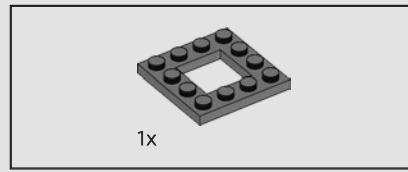
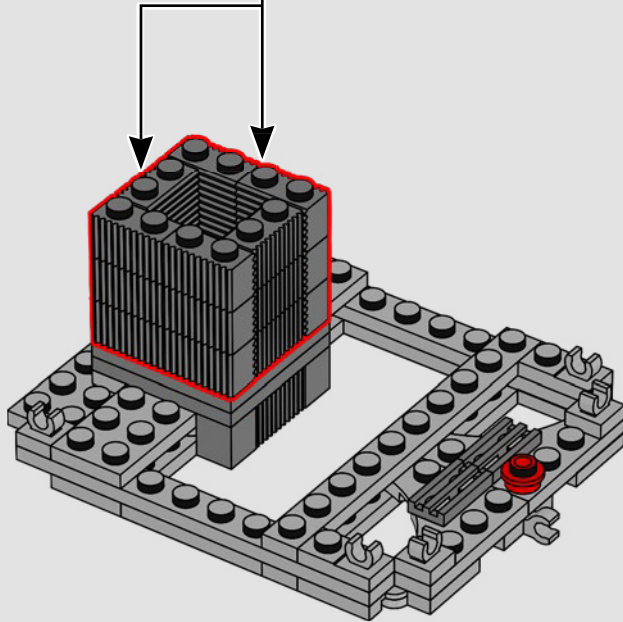
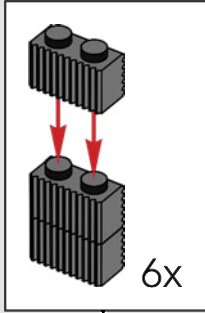

200

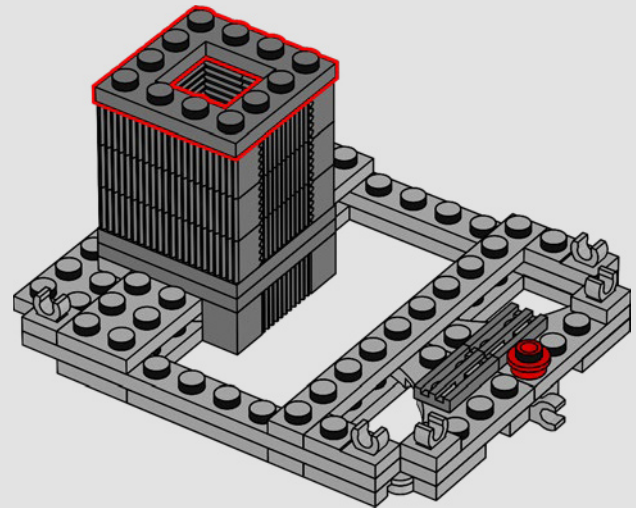

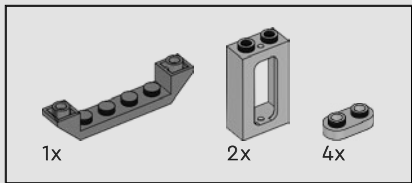

201

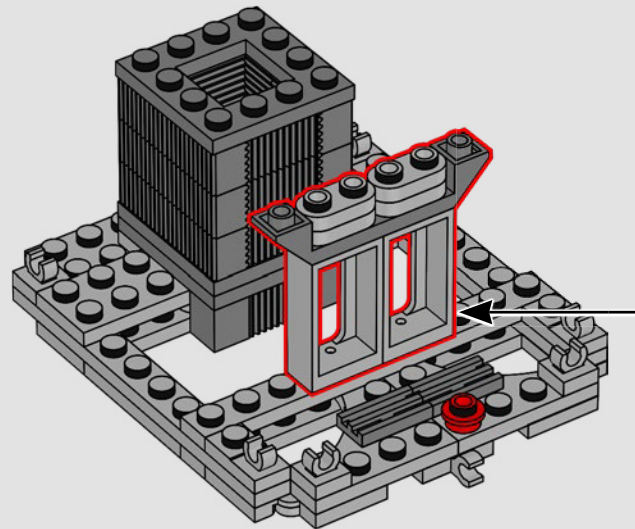
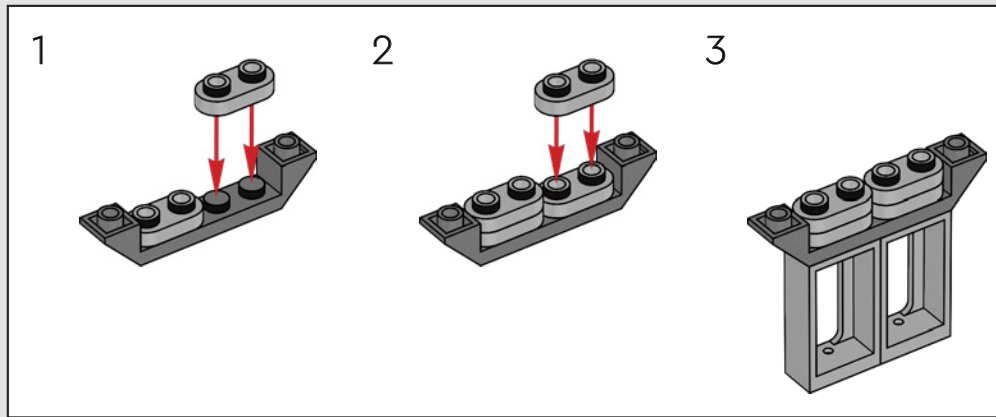



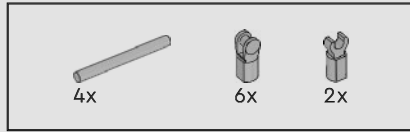
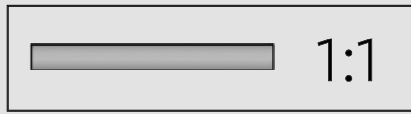
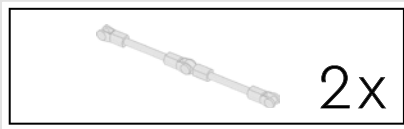

202

1

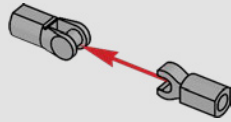

2

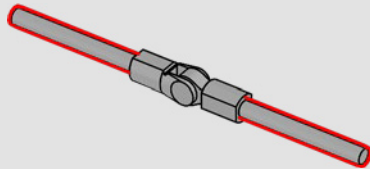

3

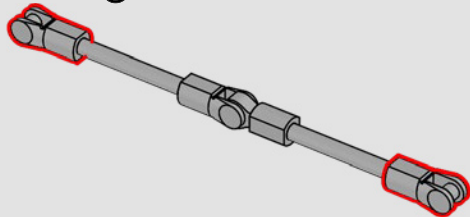

2x

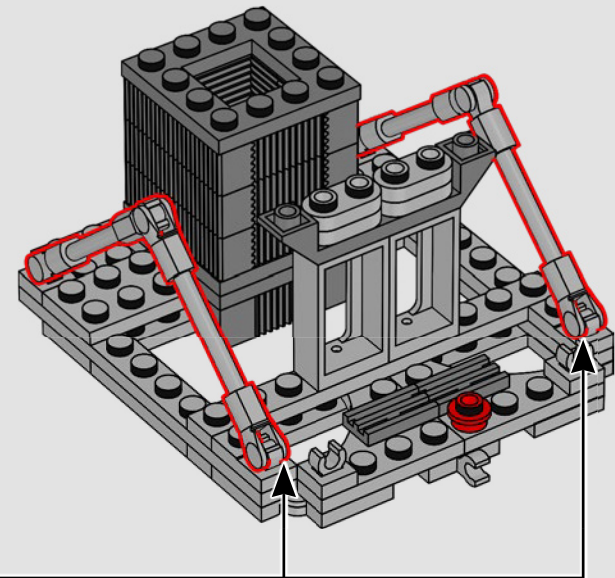
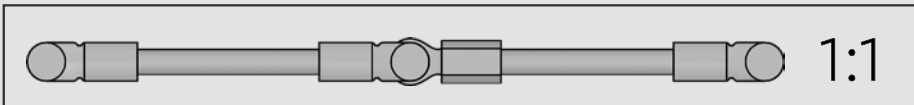



# 203

1

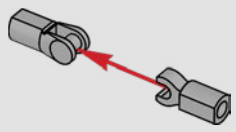

2

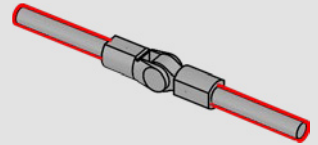

3

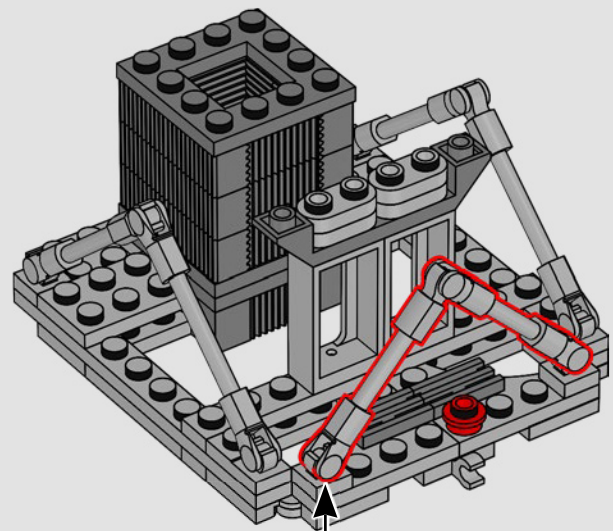
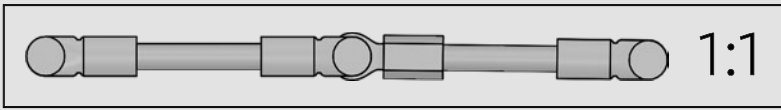
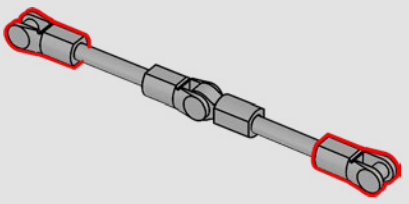

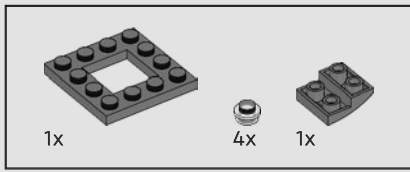

204

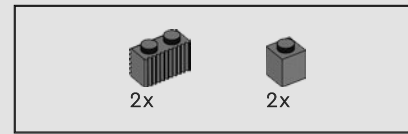
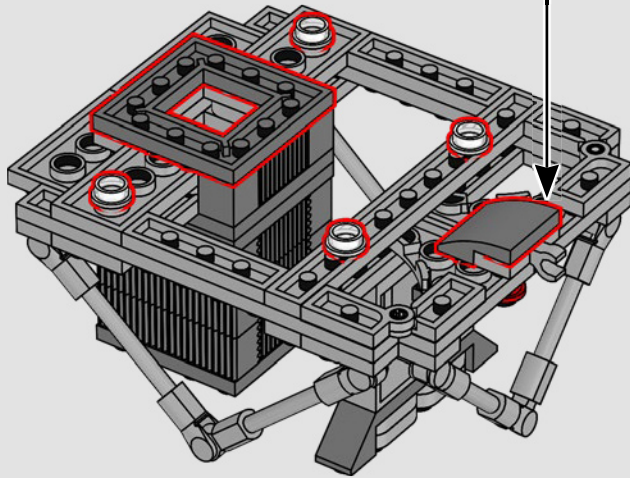
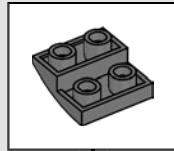

205

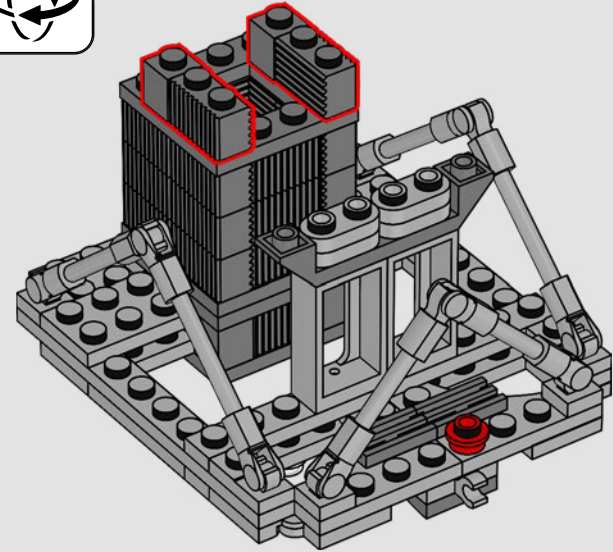

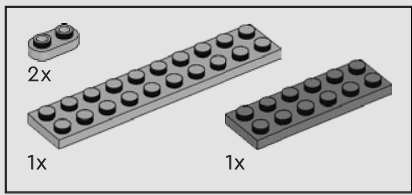

206

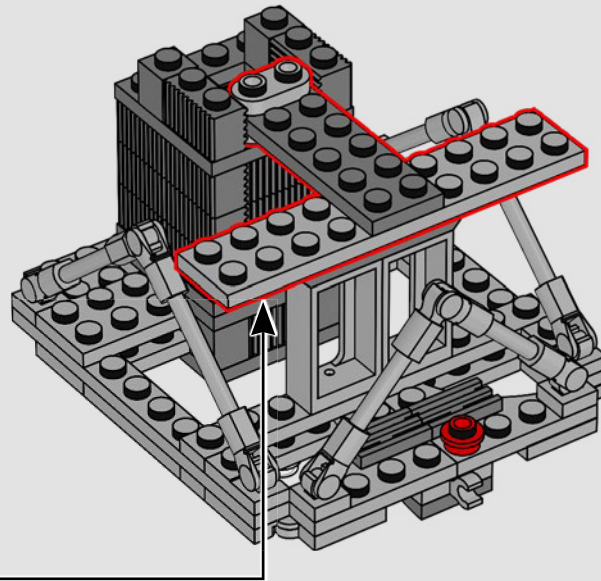
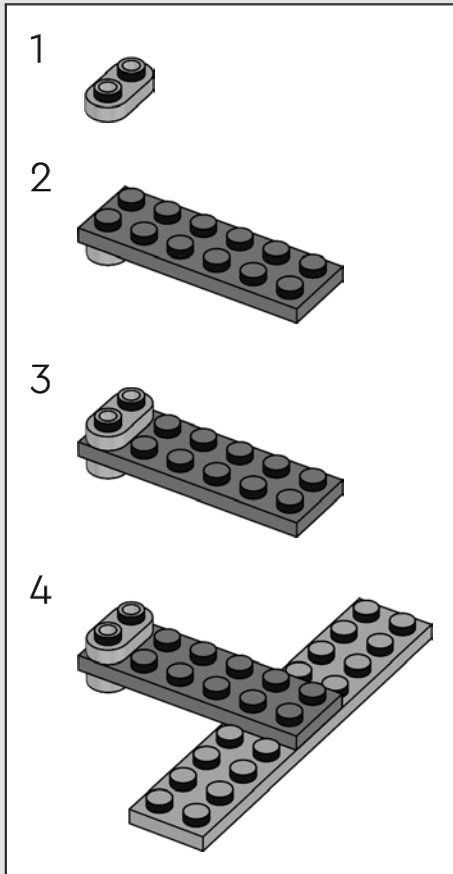

207

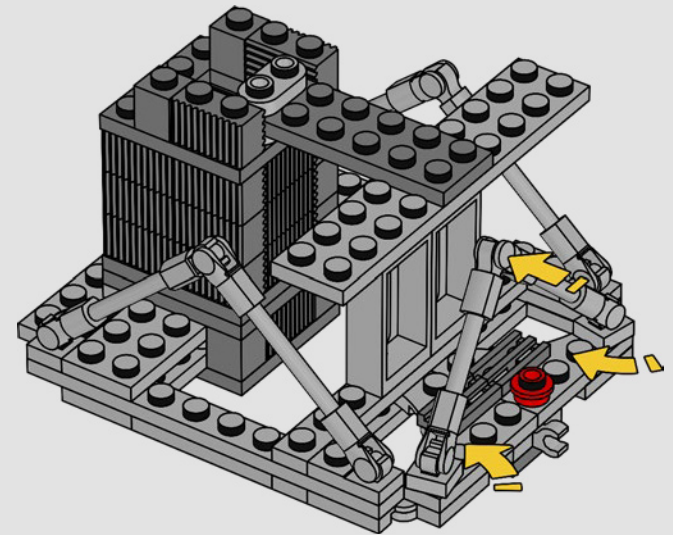

208

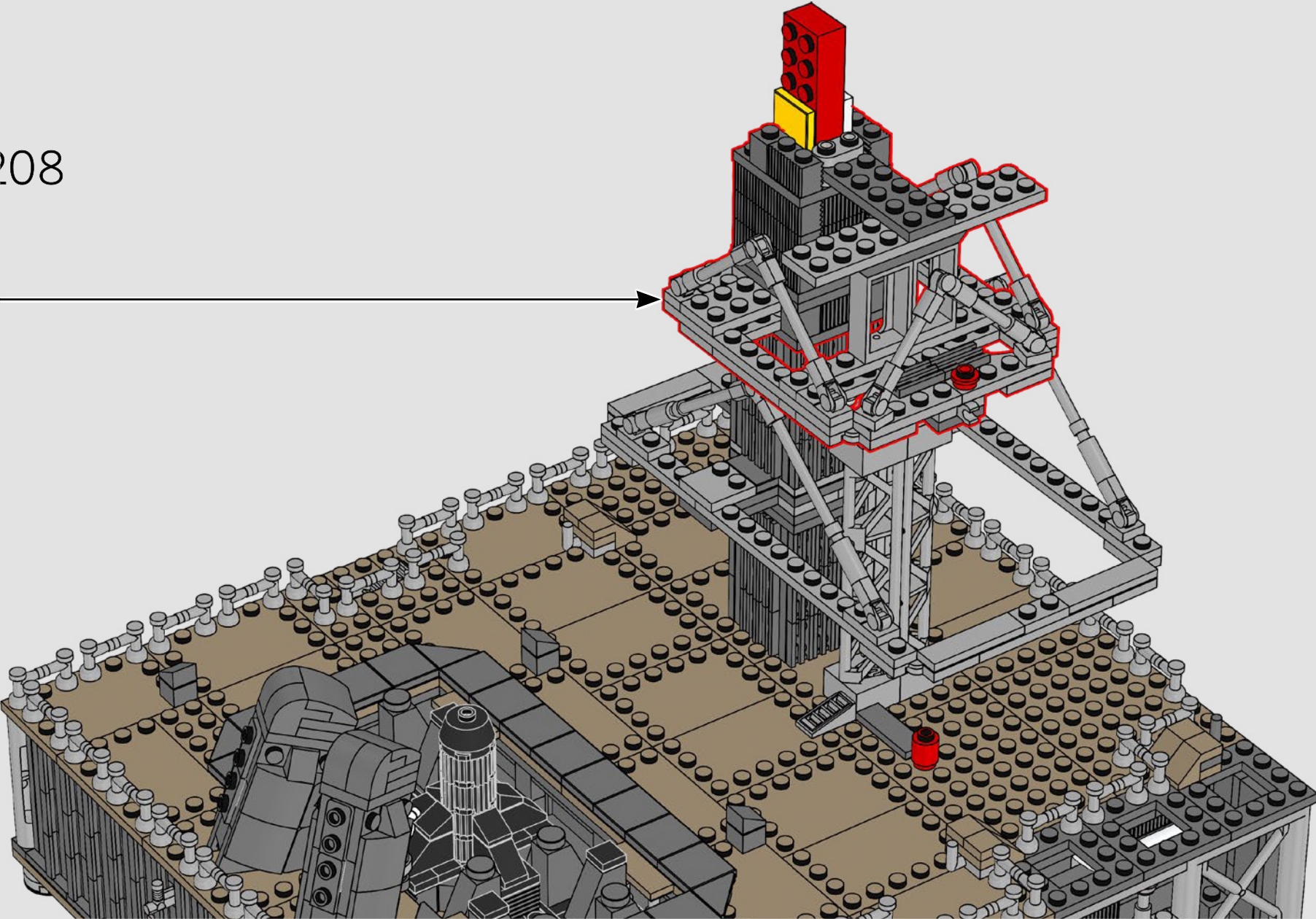

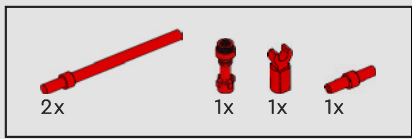

209

1

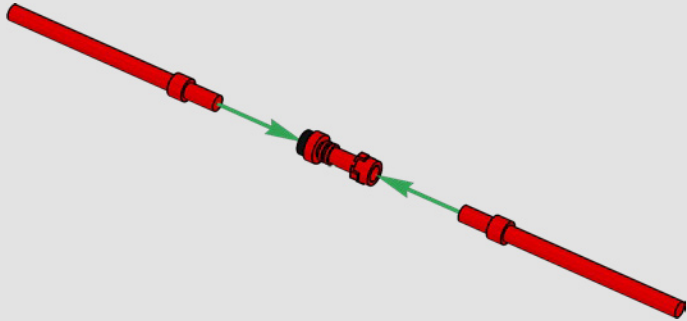

2

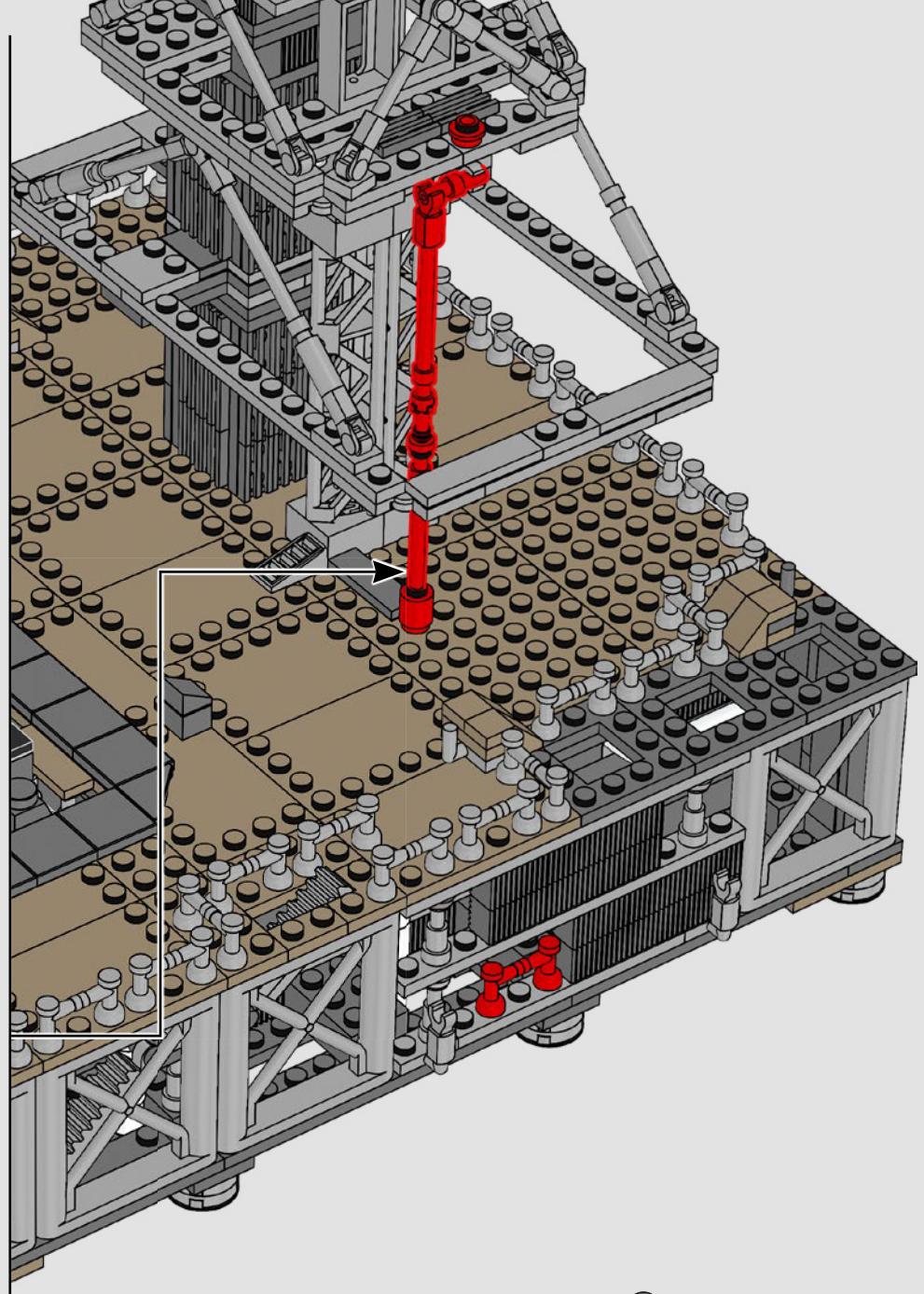
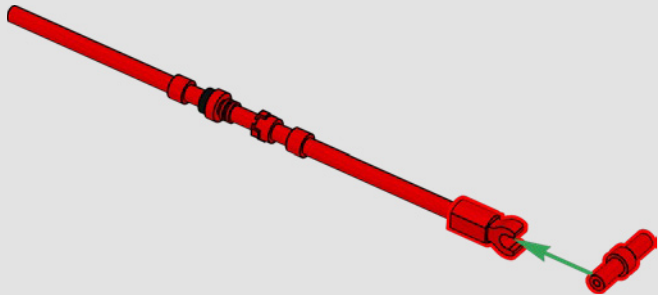

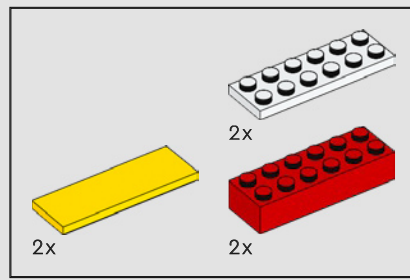

210

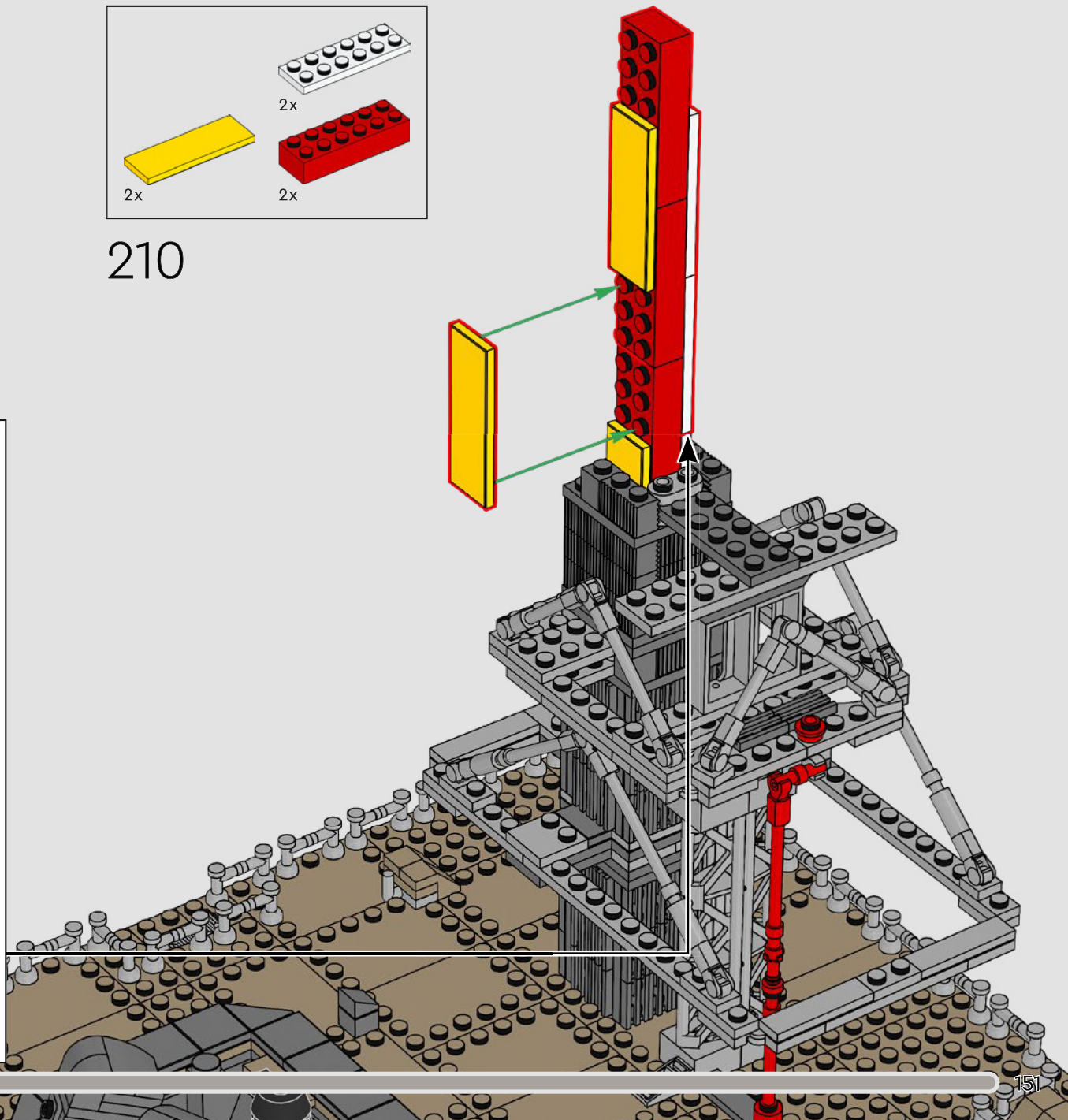
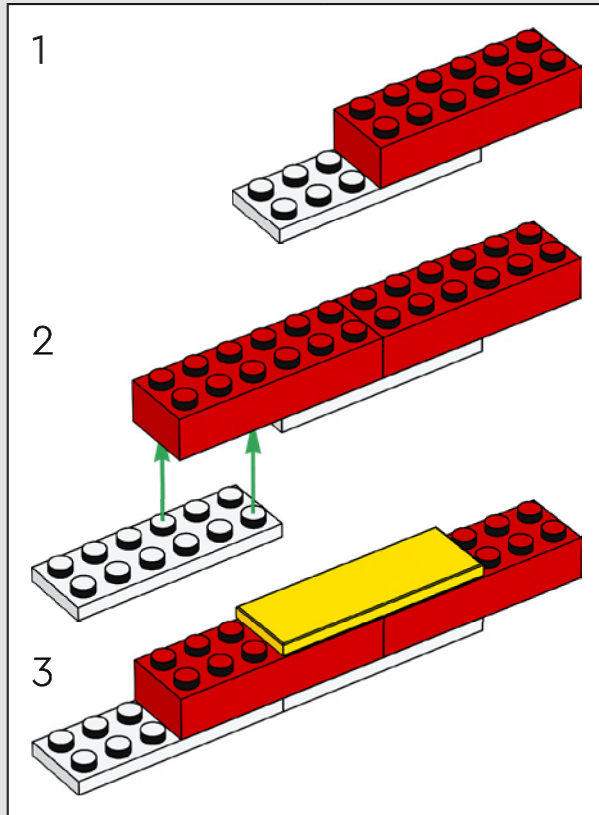

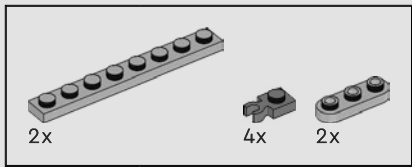

211

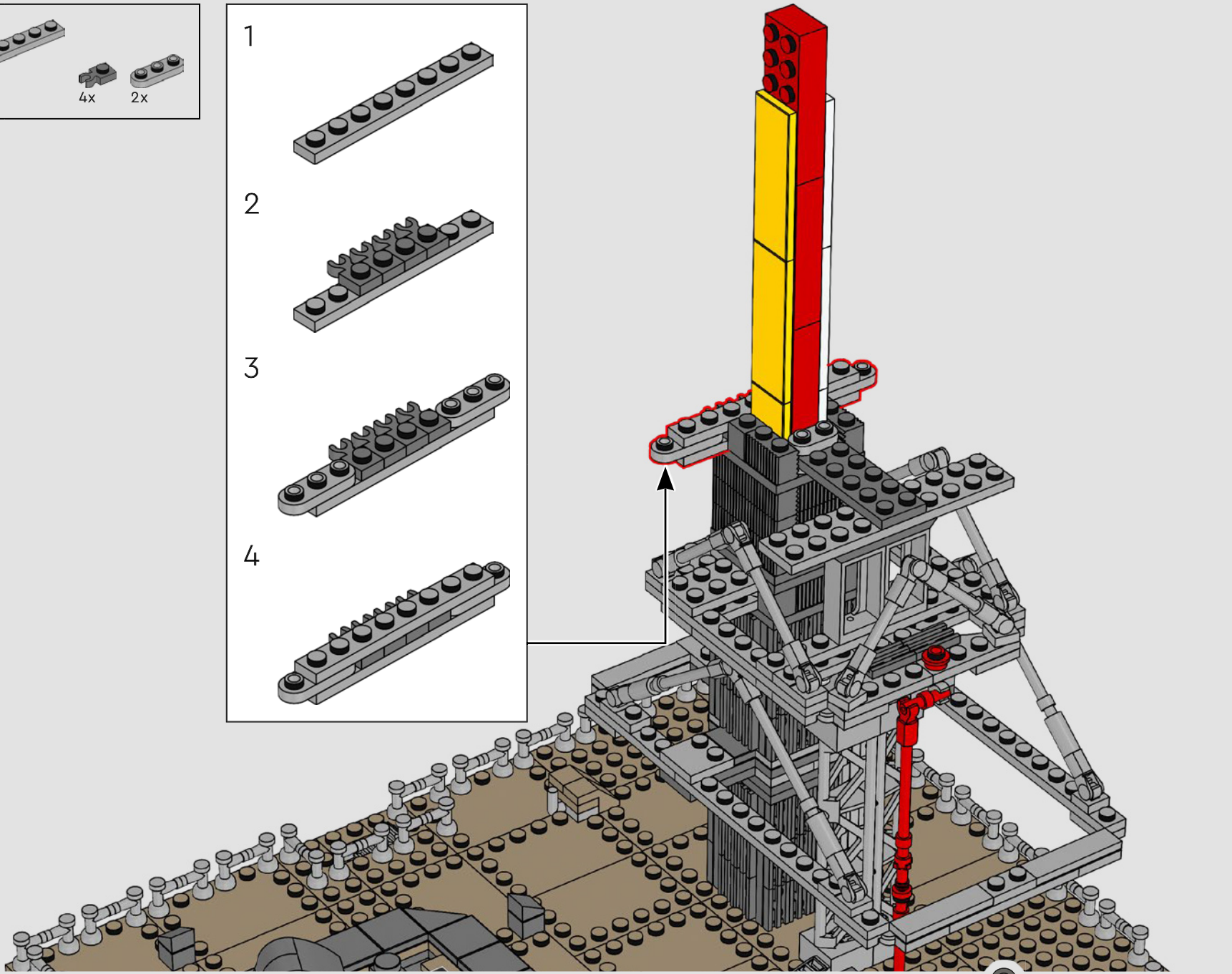
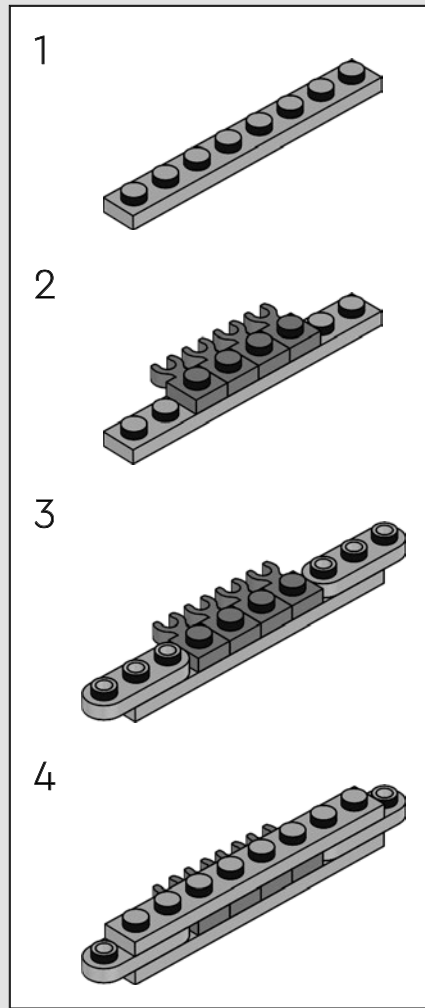



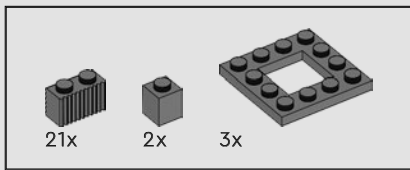

212

1

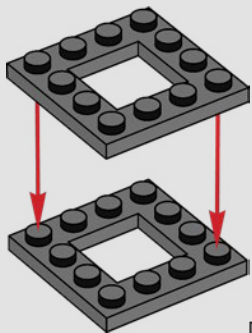

2

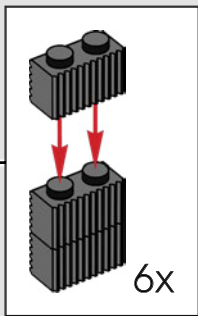
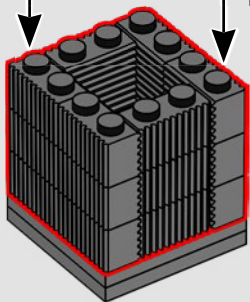

3

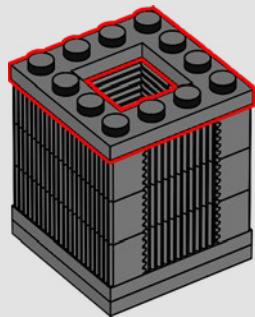

4

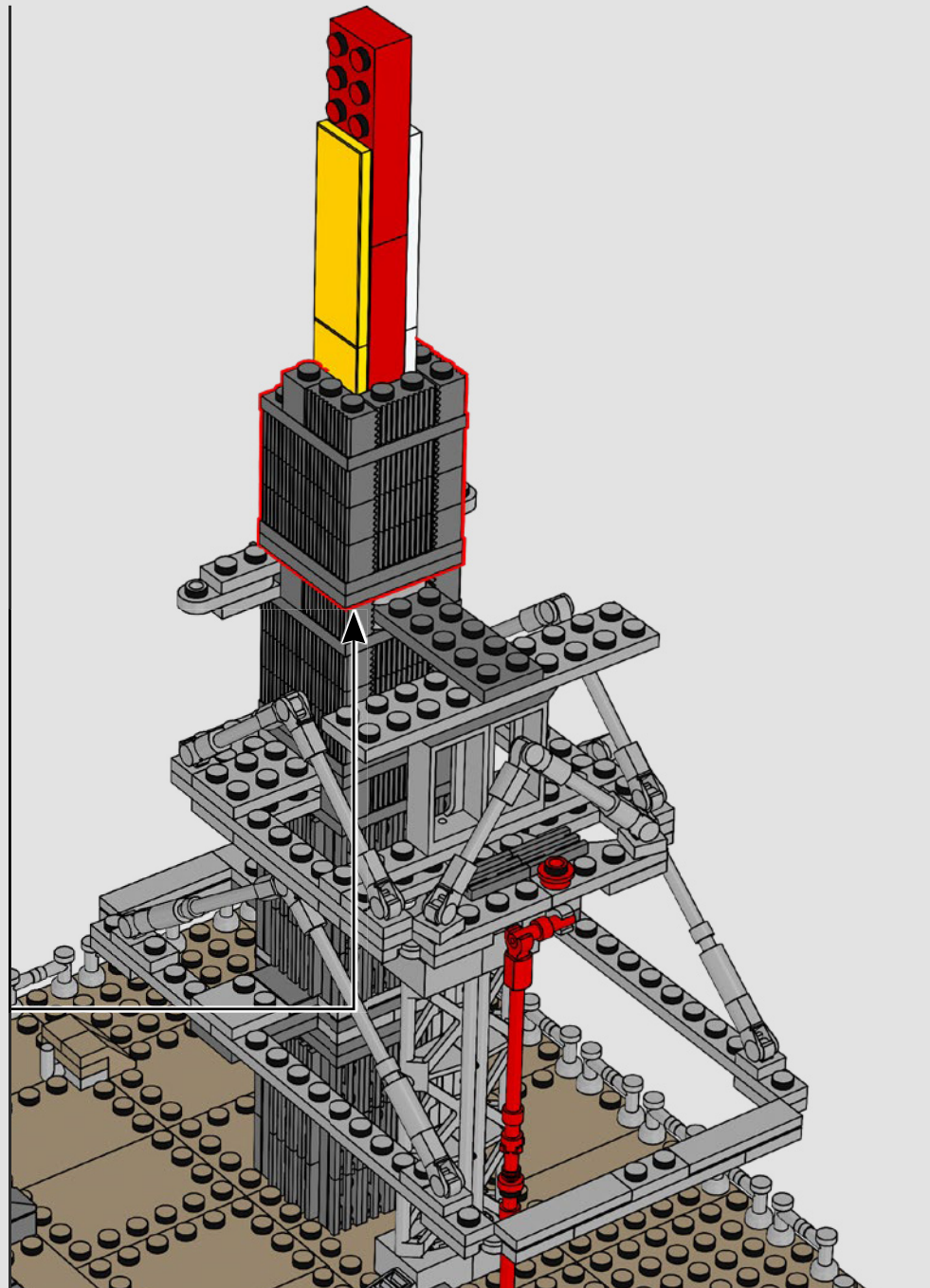
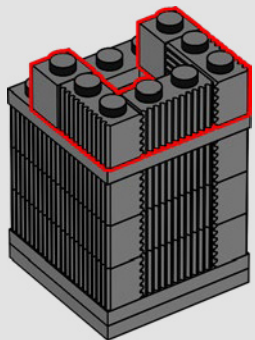

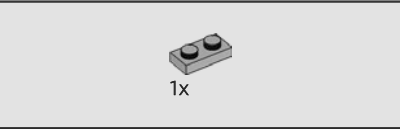
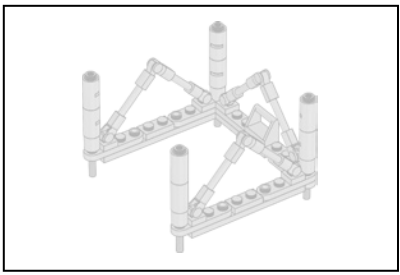

213

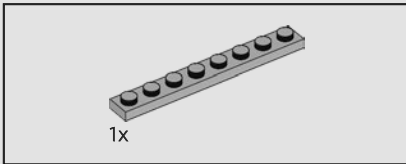
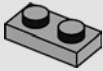

214

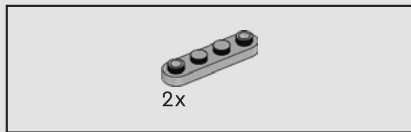
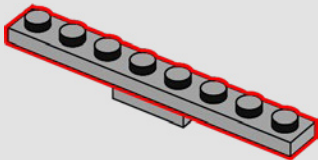

215

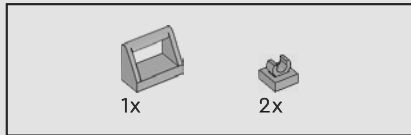
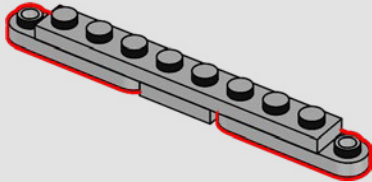

216

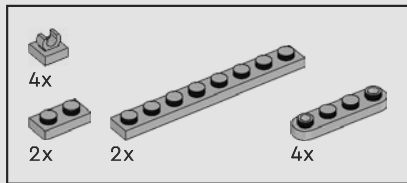
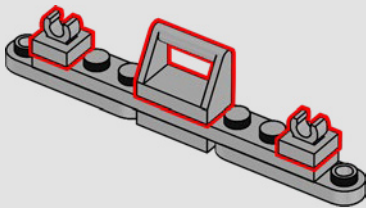

217

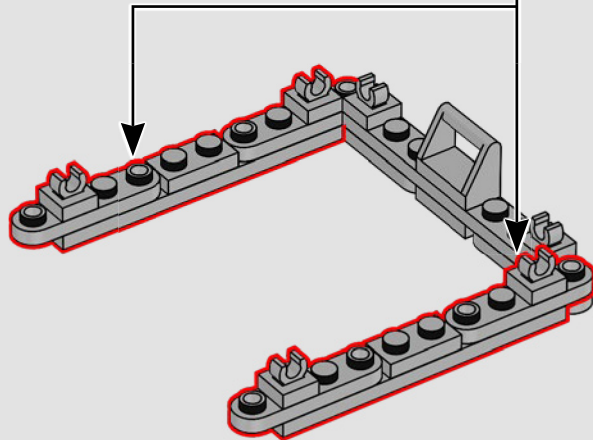
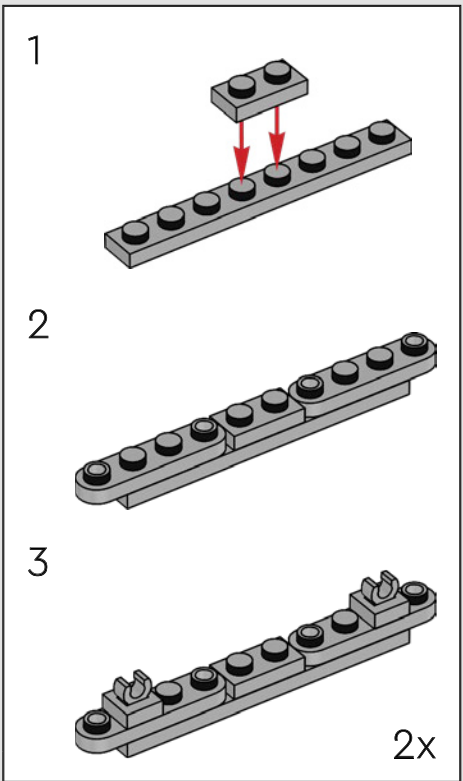

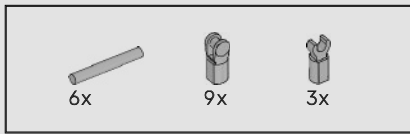

218

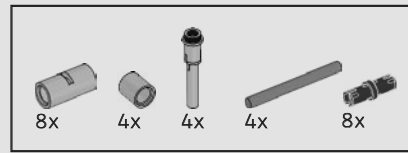
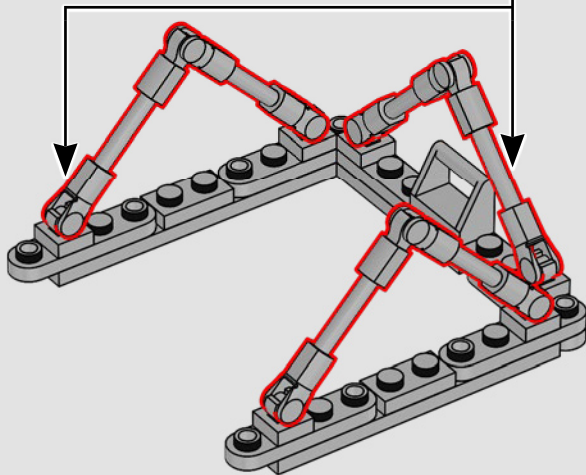
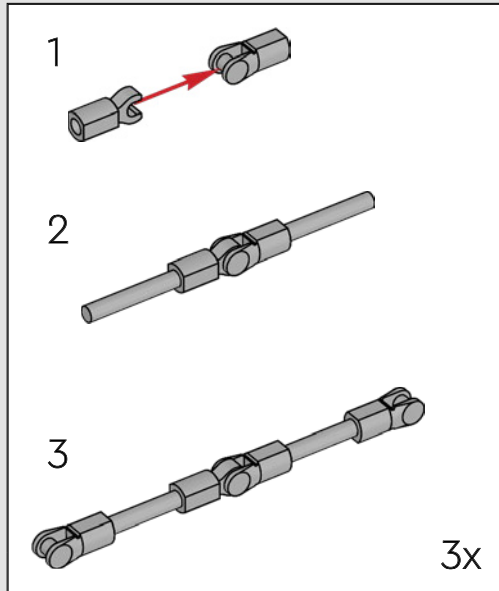

219

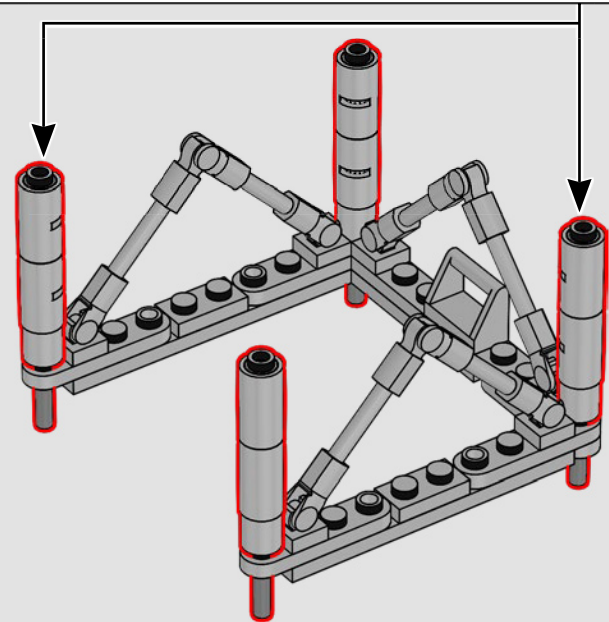
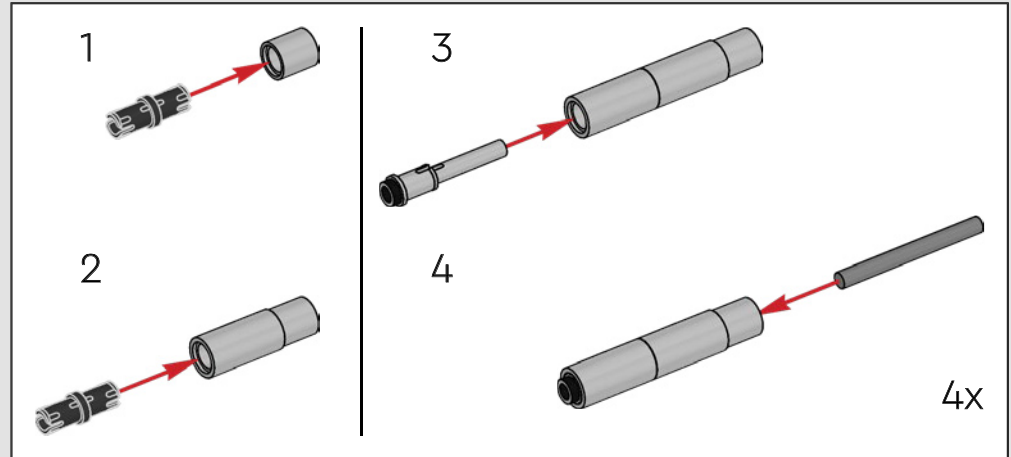

220

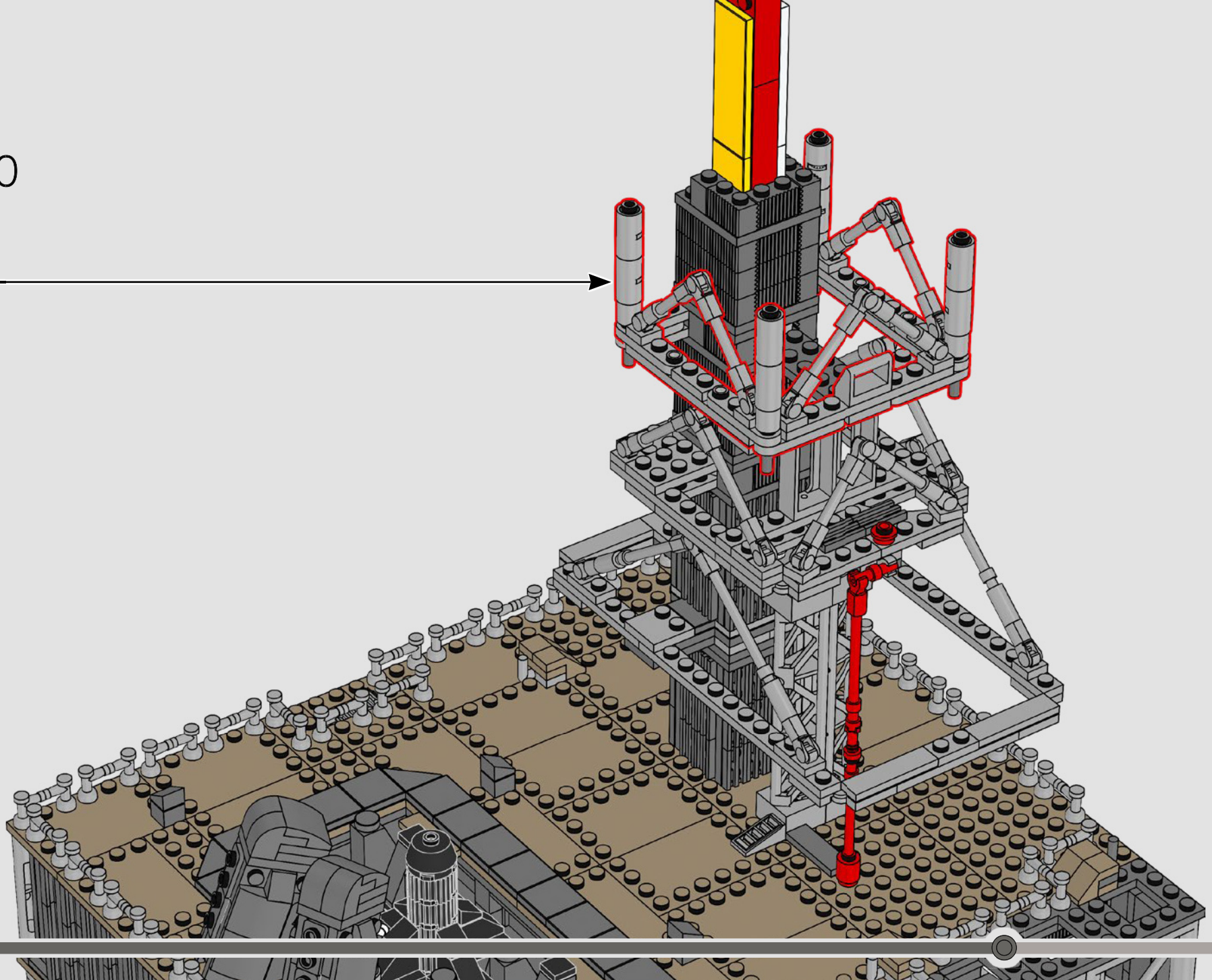

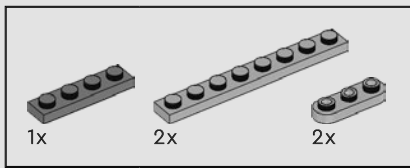

221

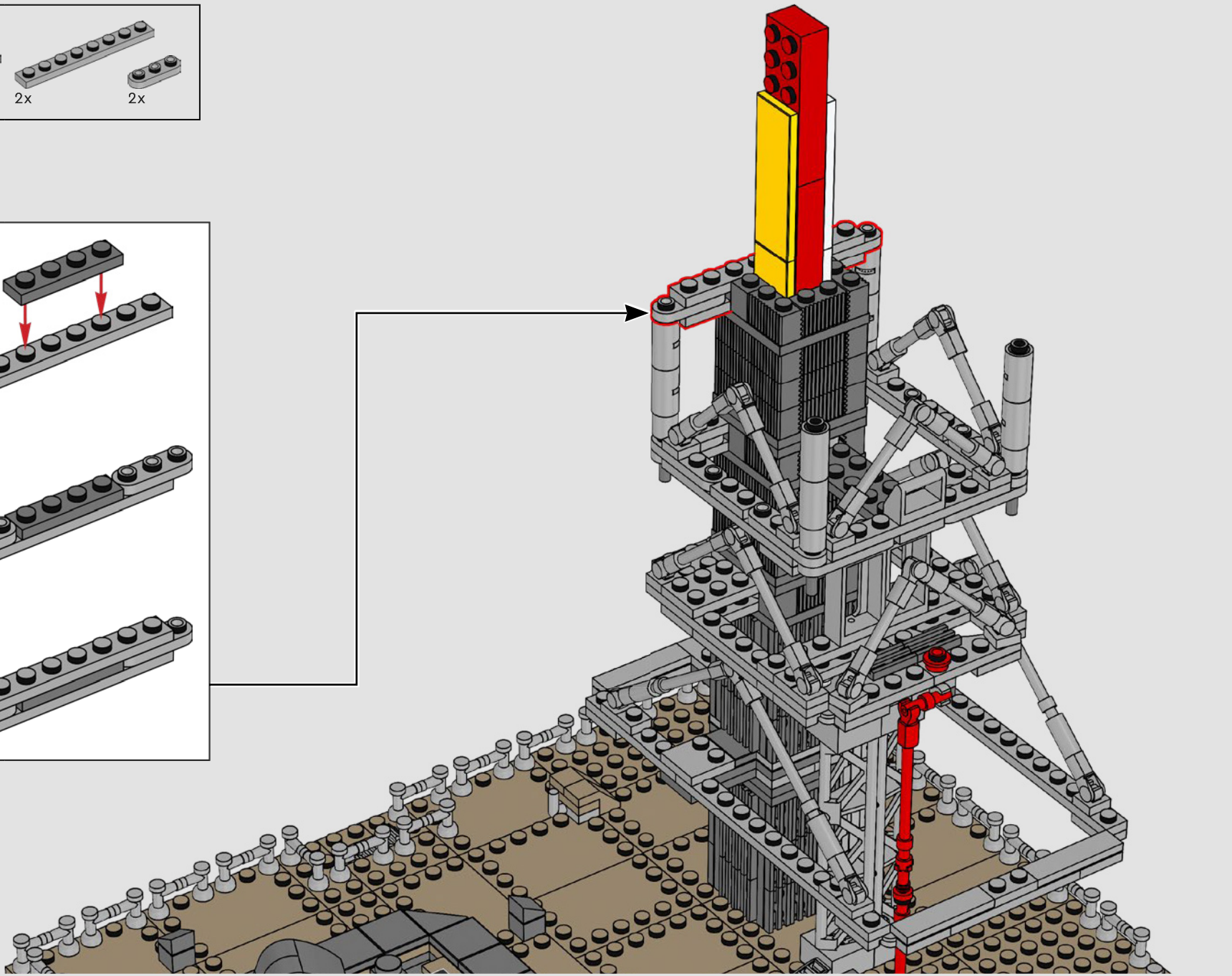
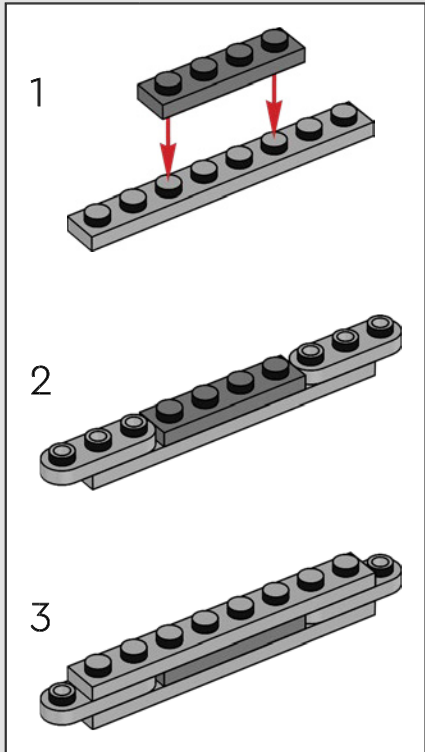



222

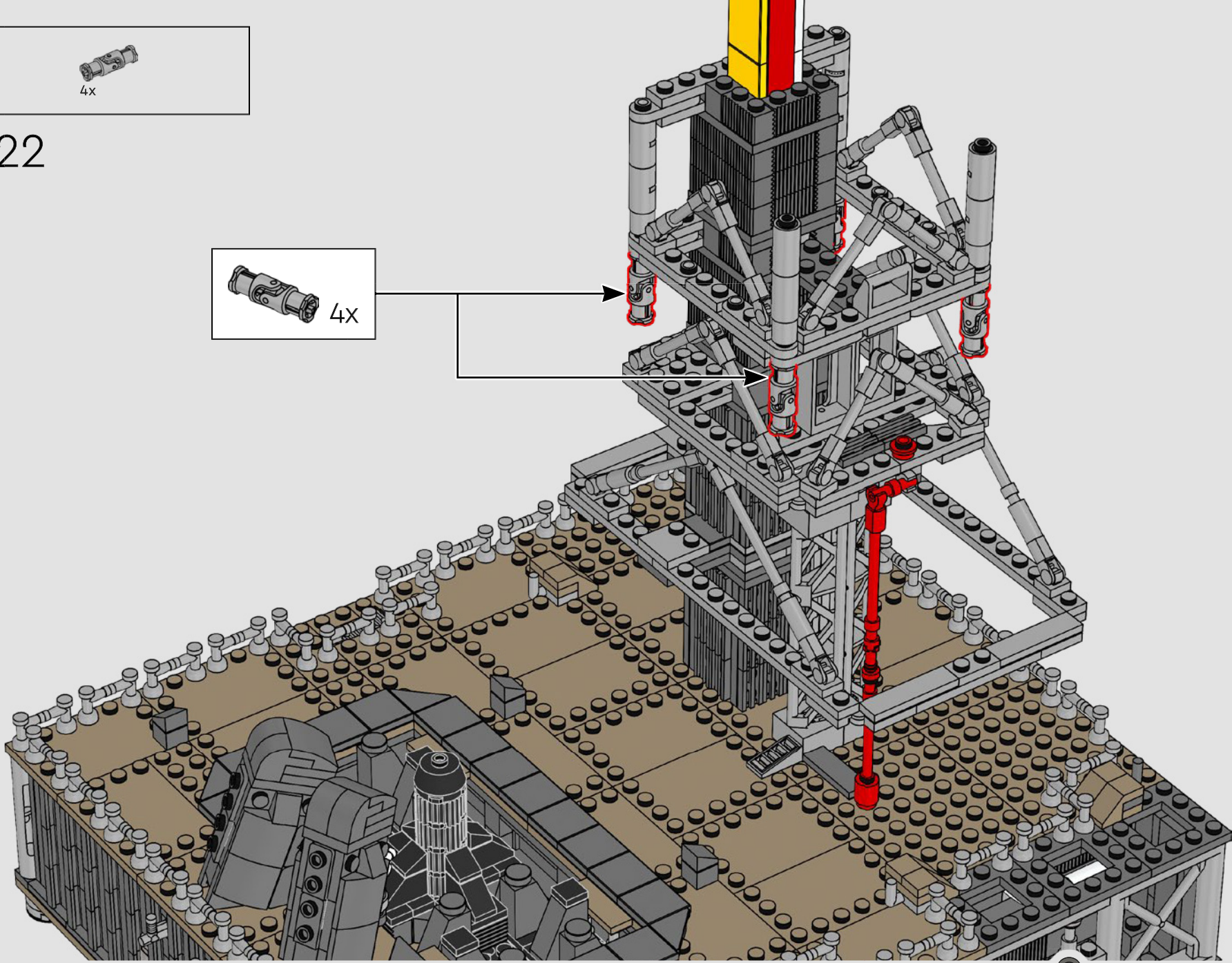
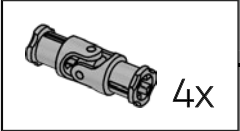

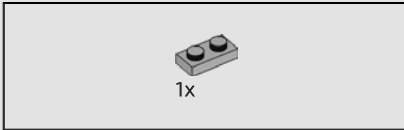
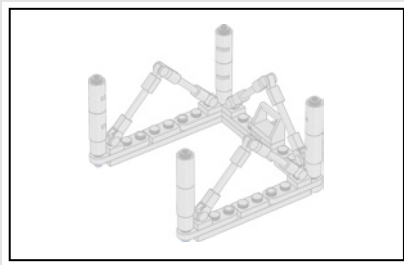

223

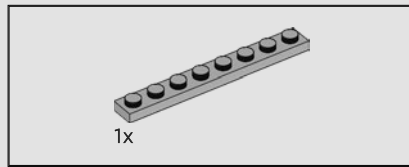
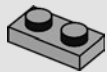

224

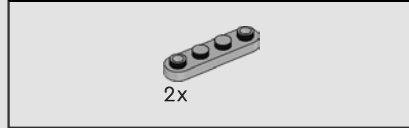
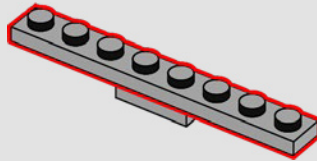

225

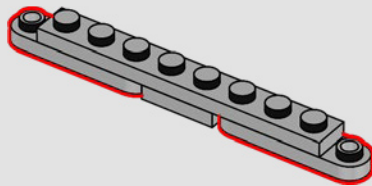

226

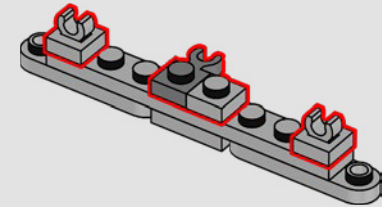

227

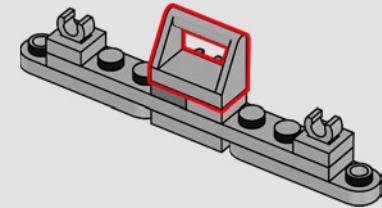

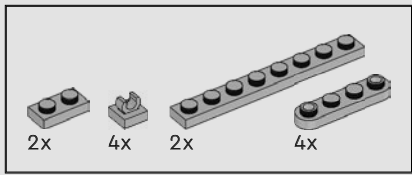

228

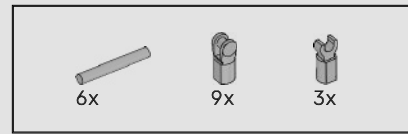
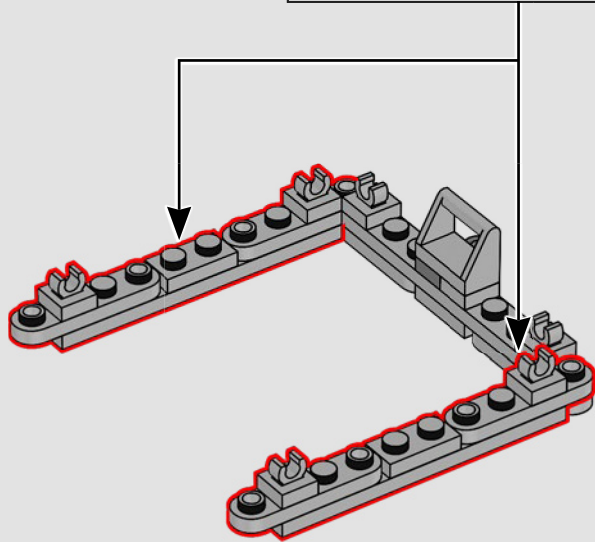
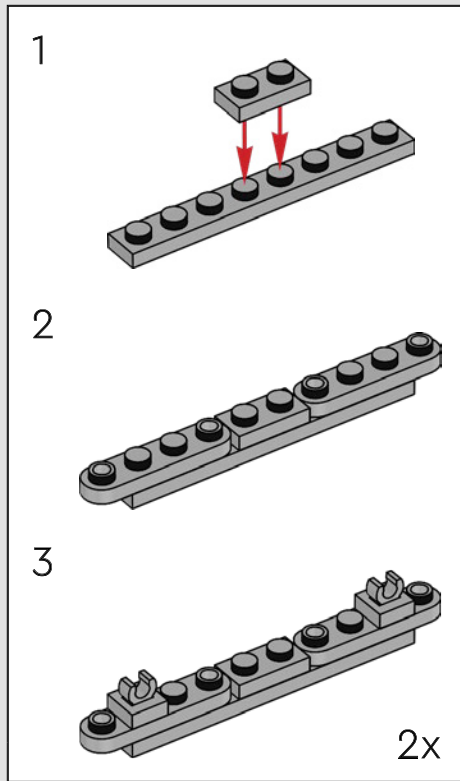

229

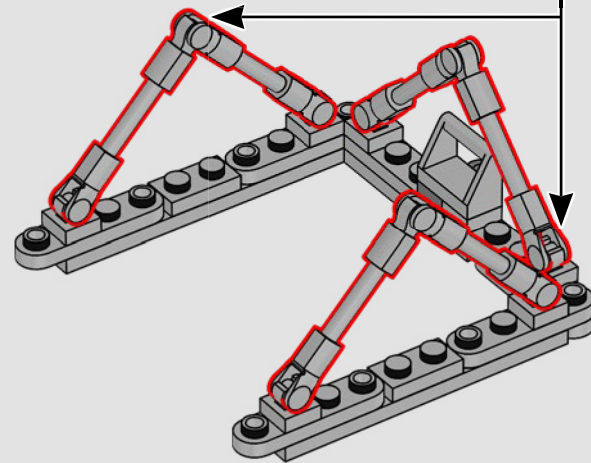
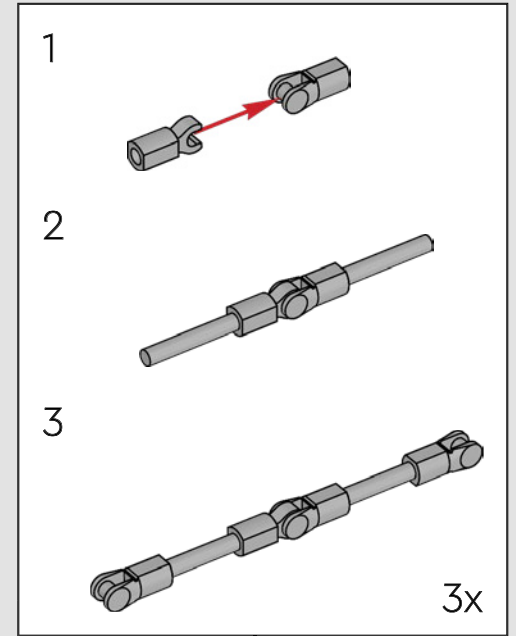



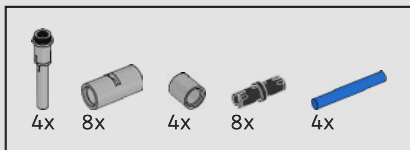

230

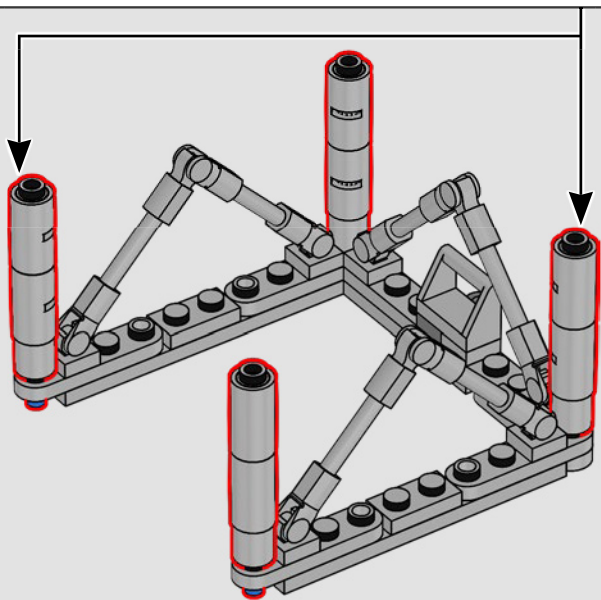
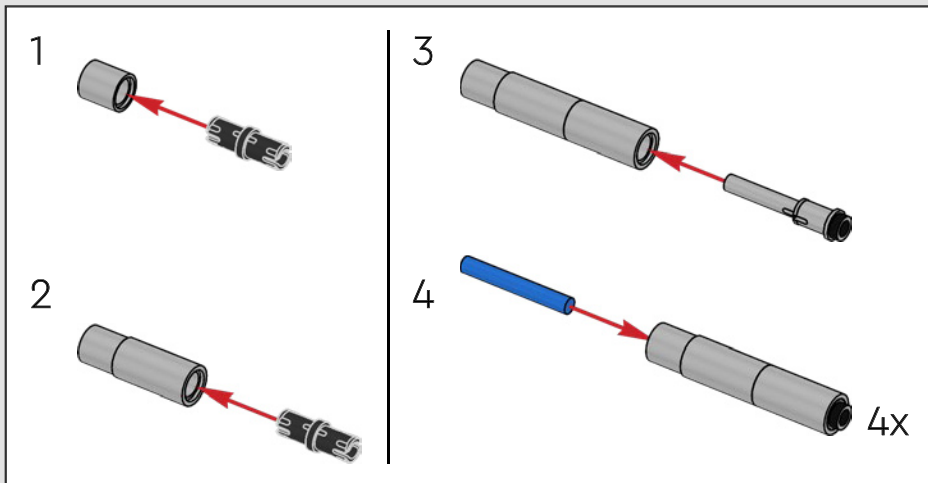

231

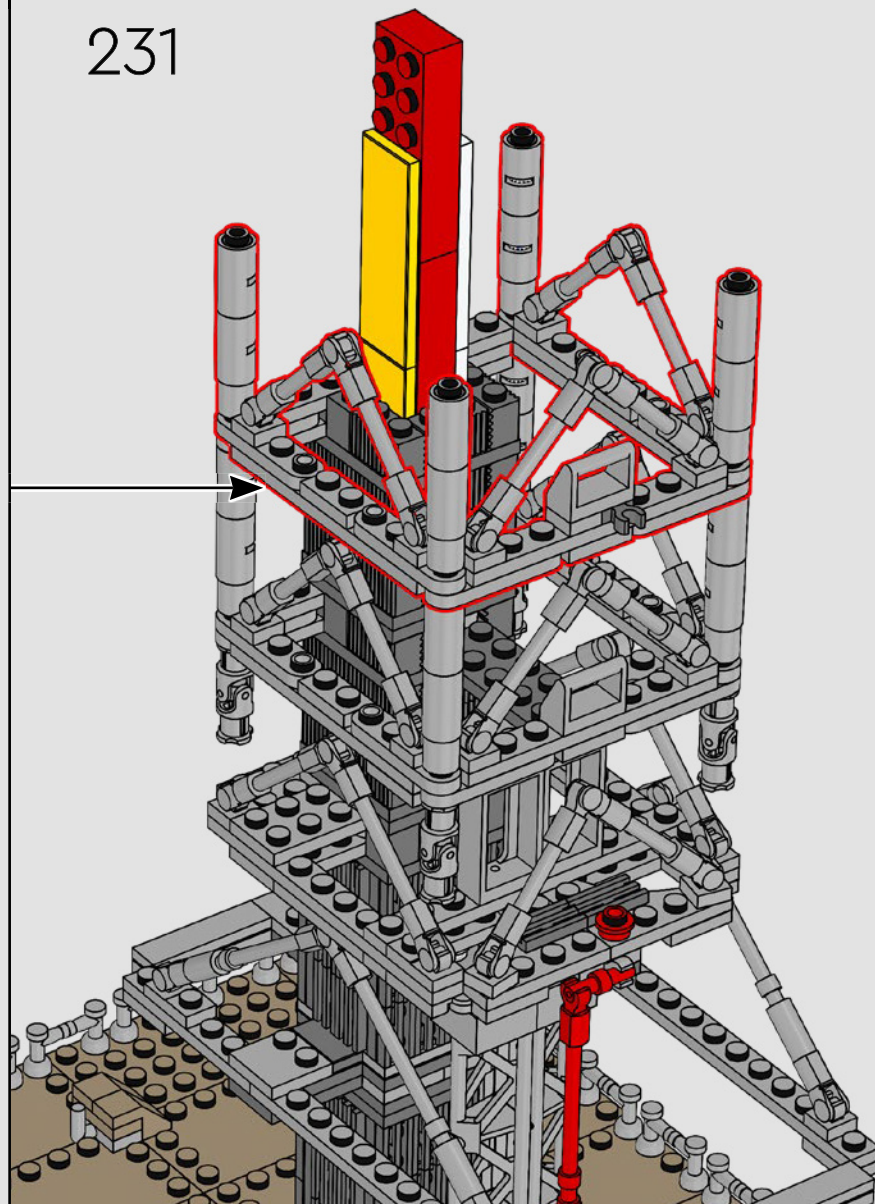

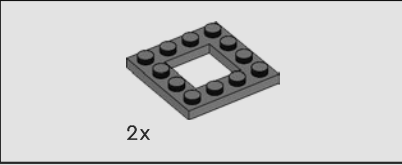
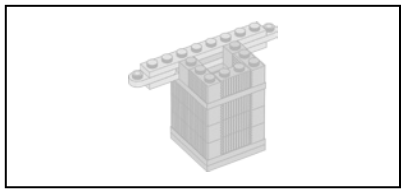

232

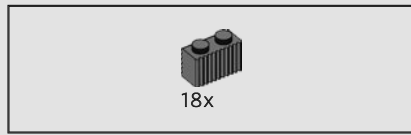
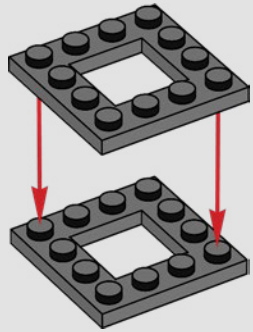

233

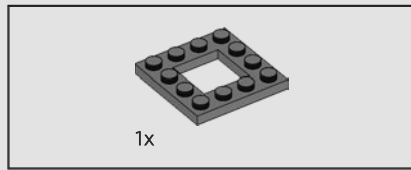
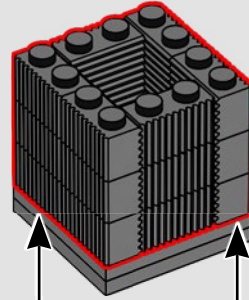
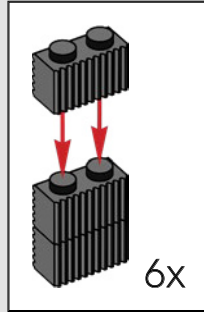

234

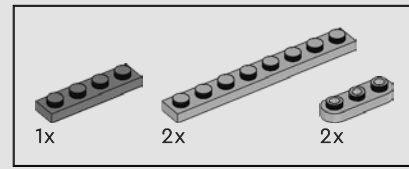
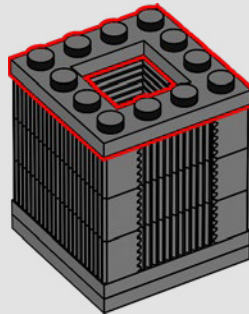

235

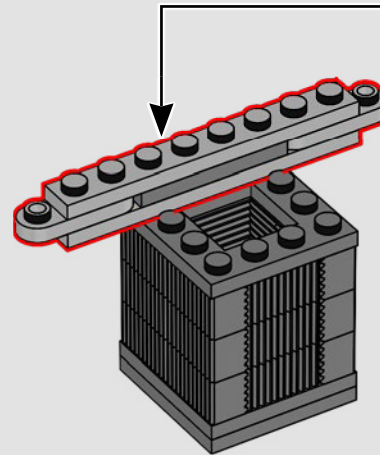
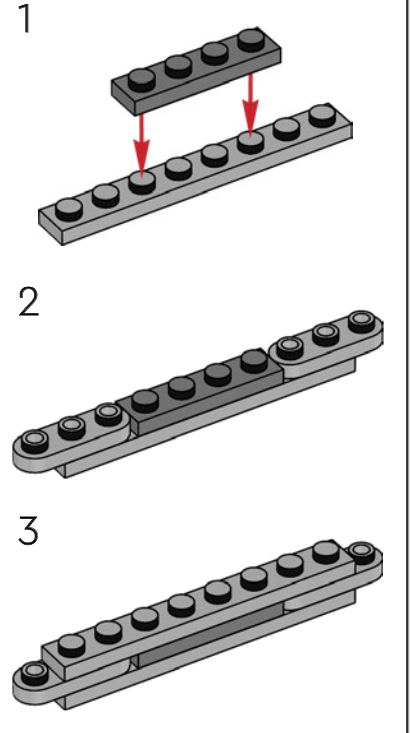

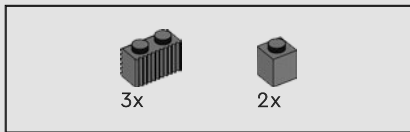

236

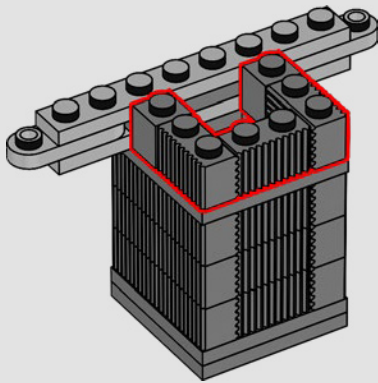

237

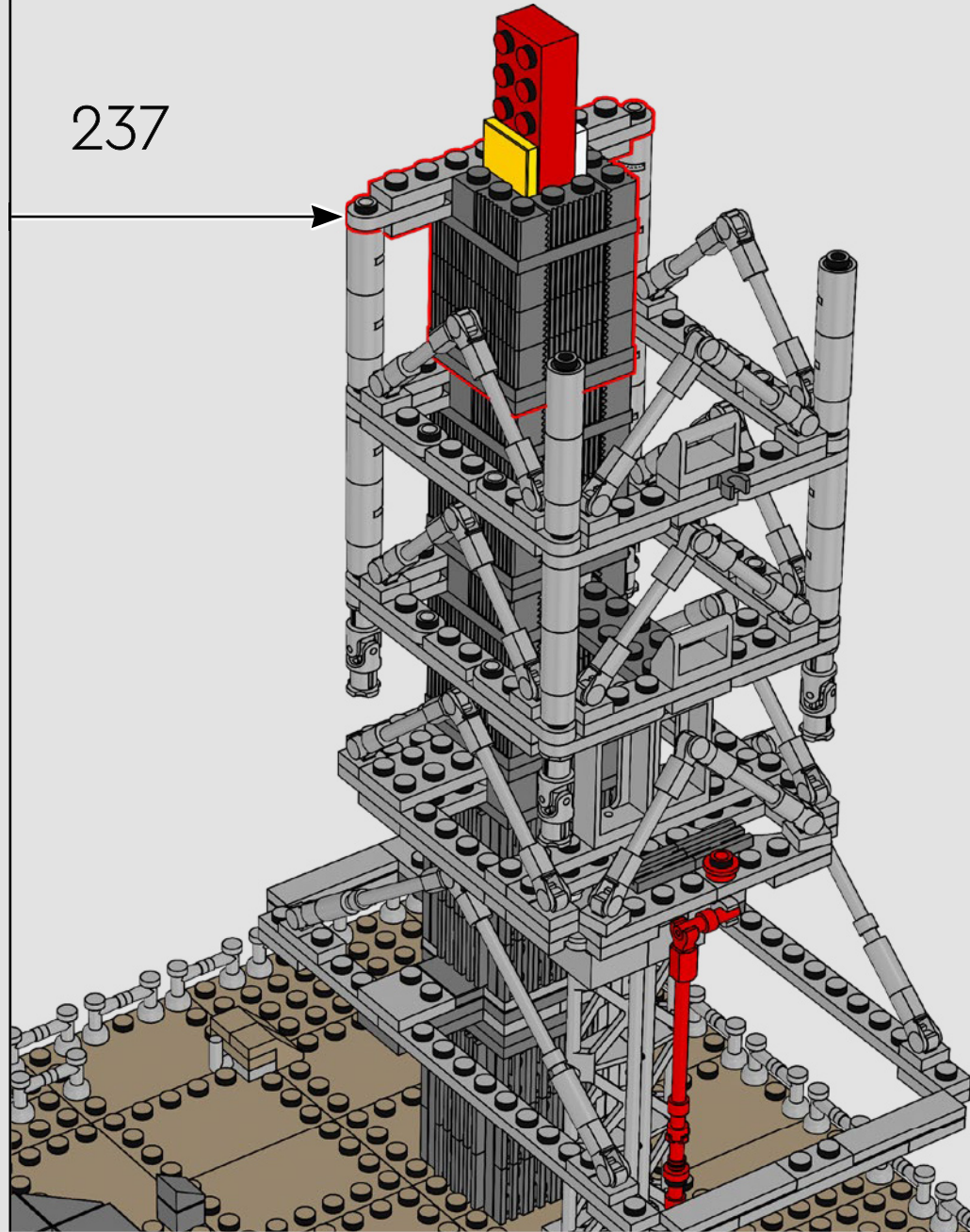

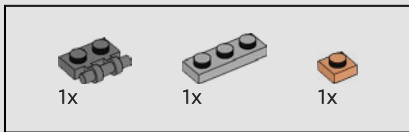

238

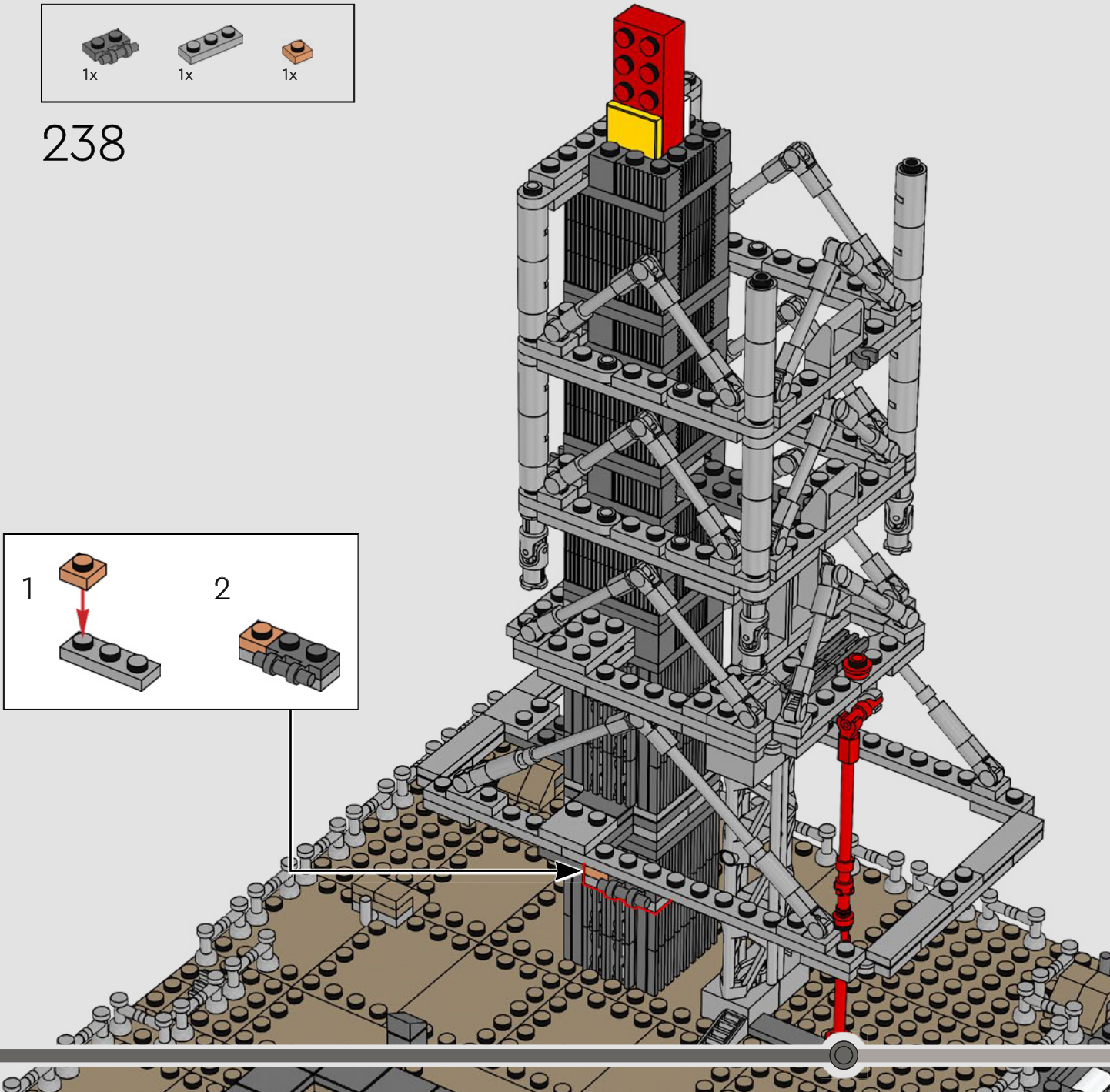
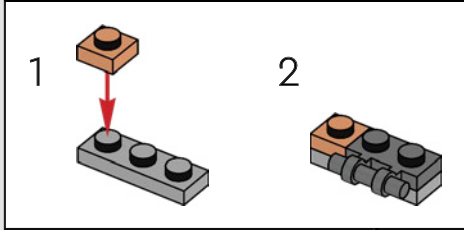

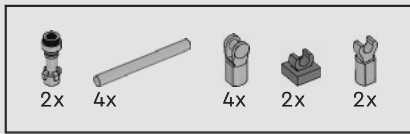

239

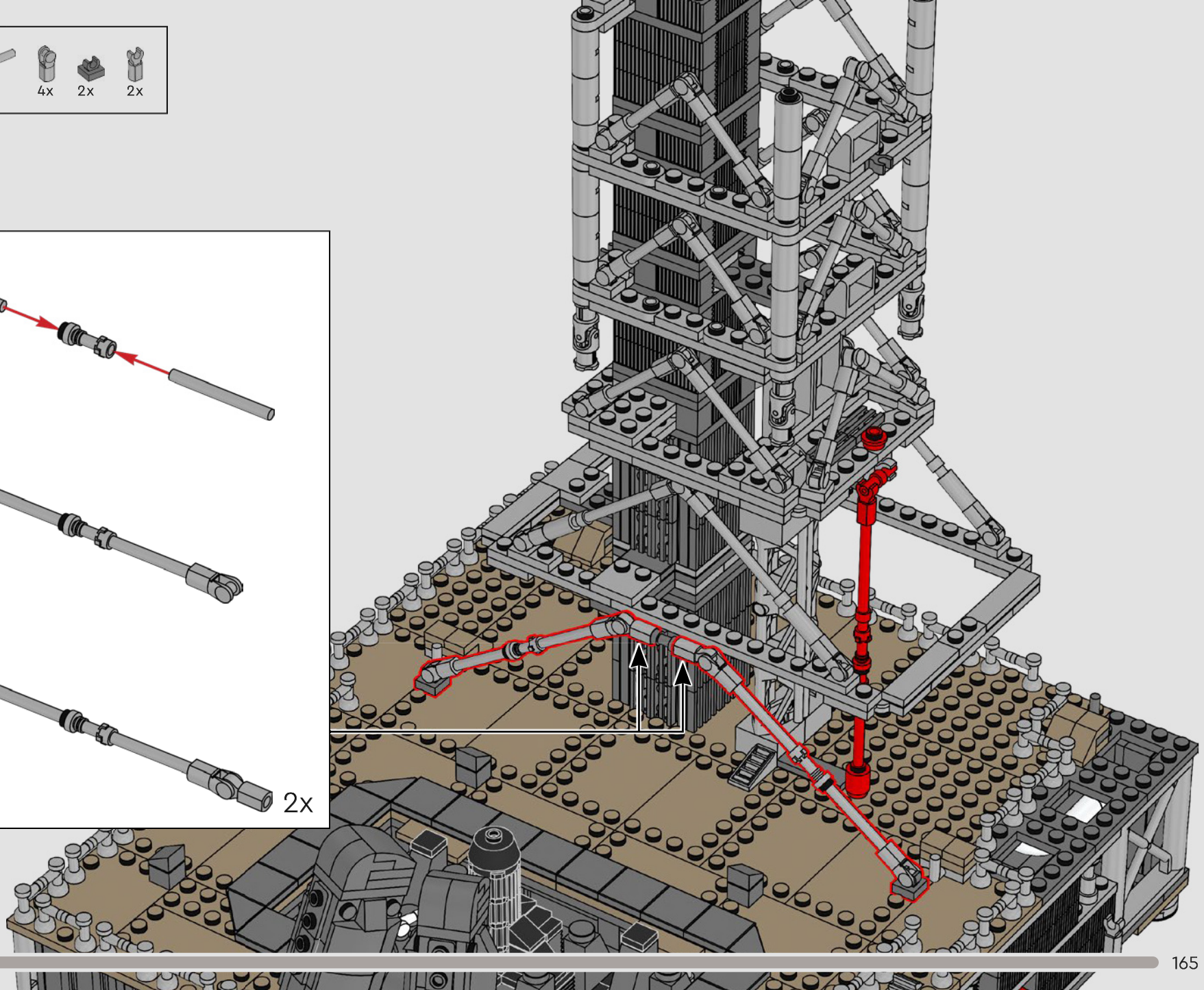
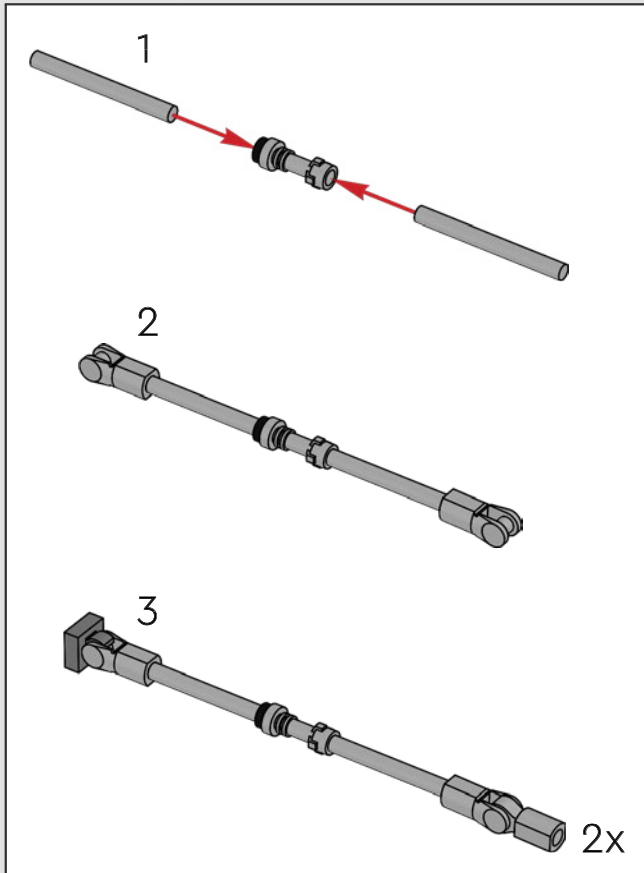

240

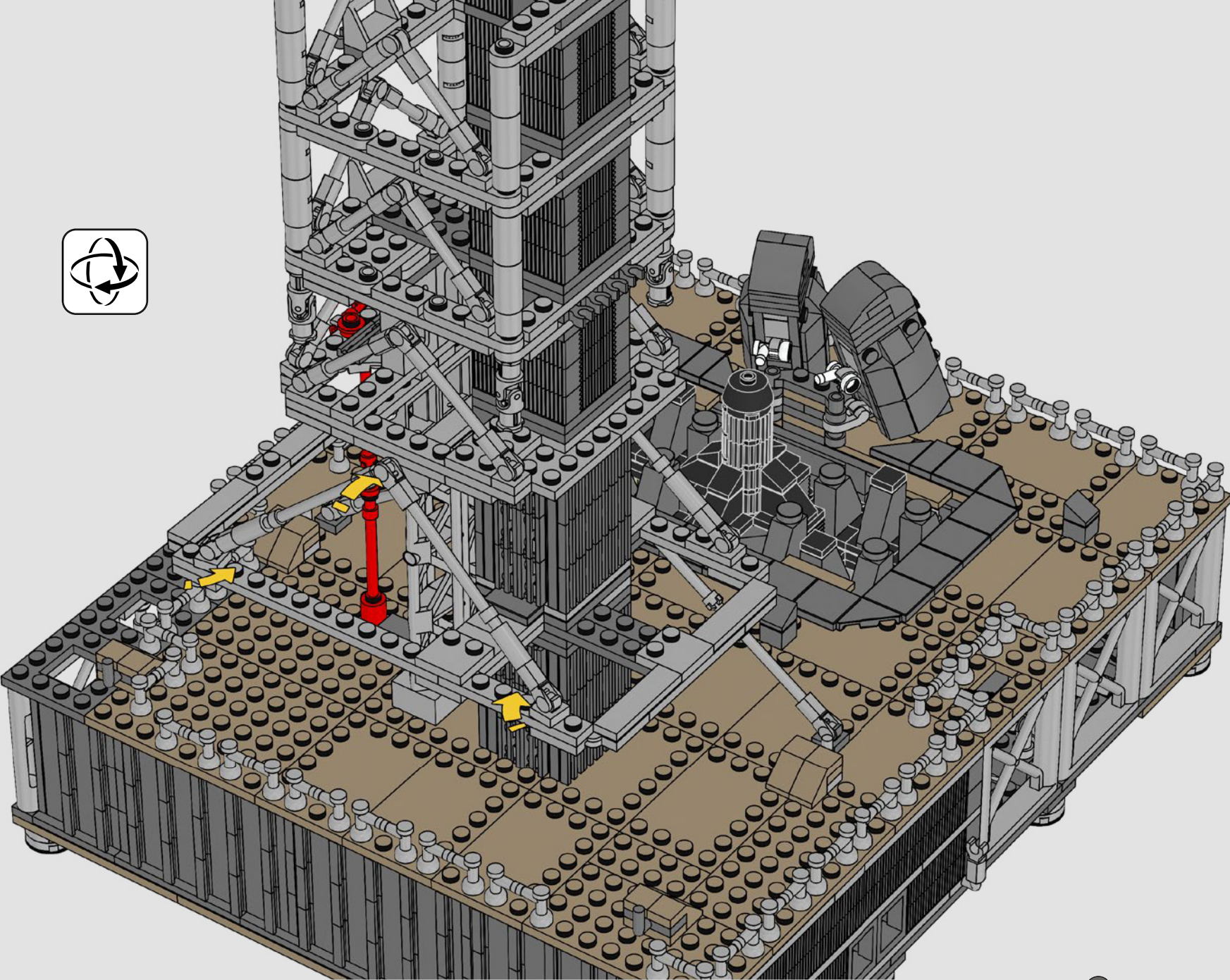

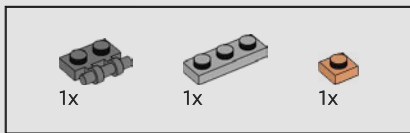

241

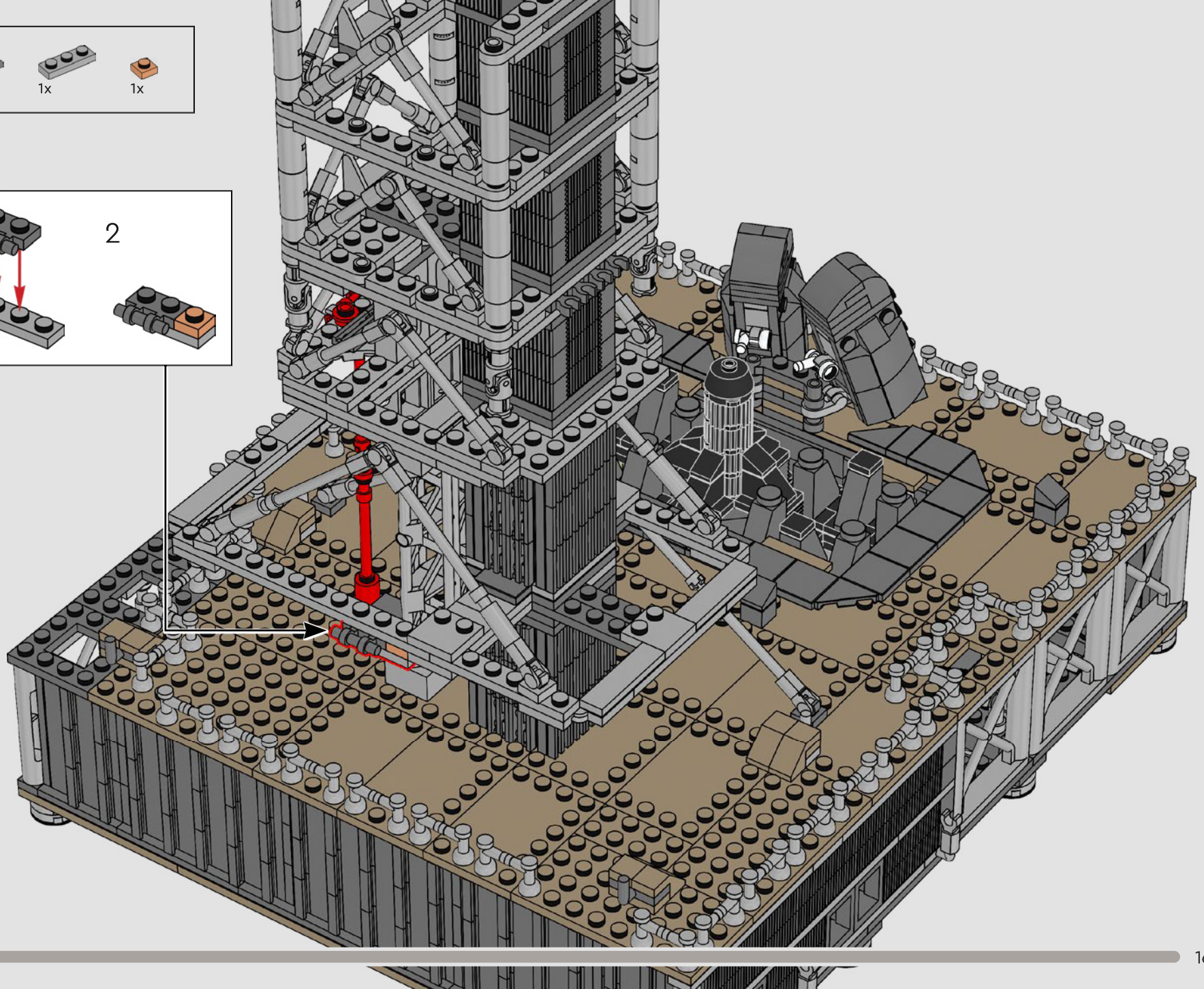
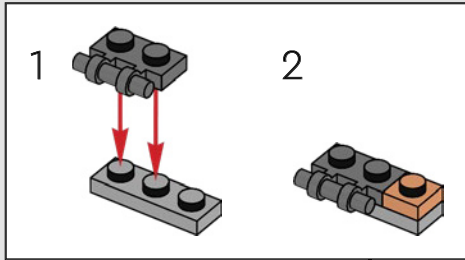

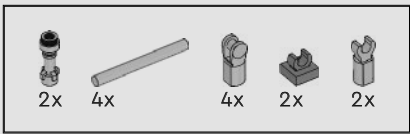

242

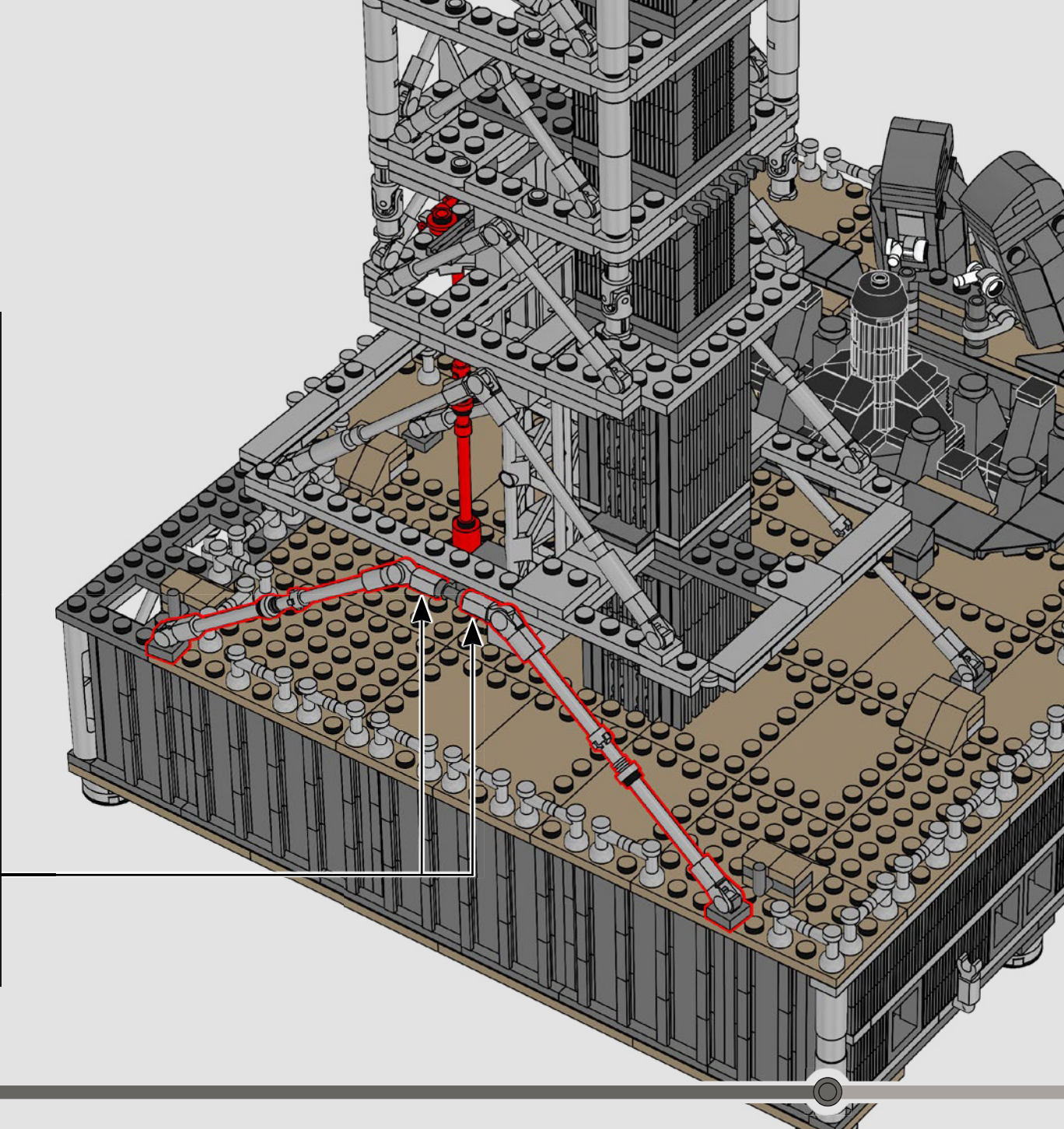
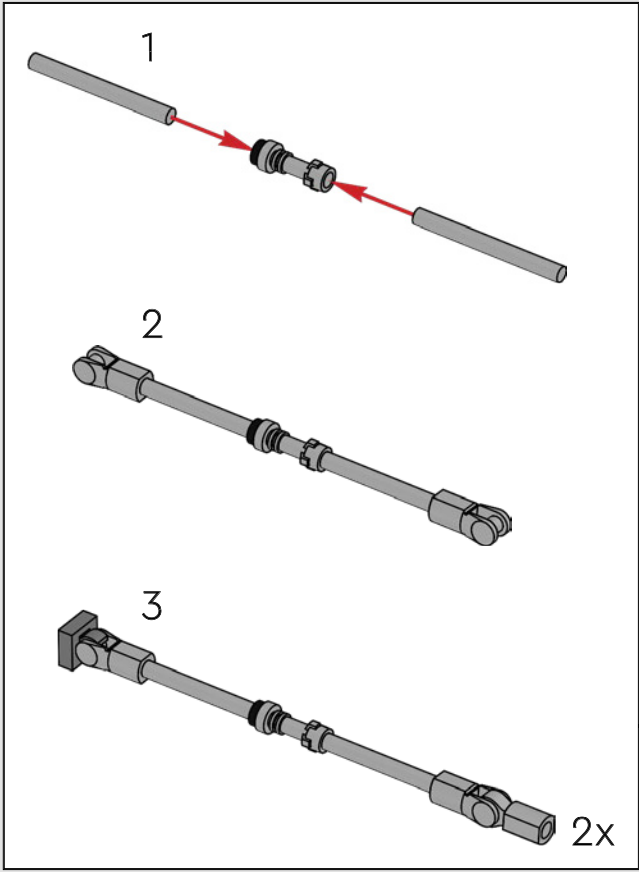



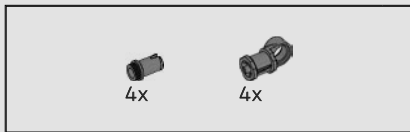

243

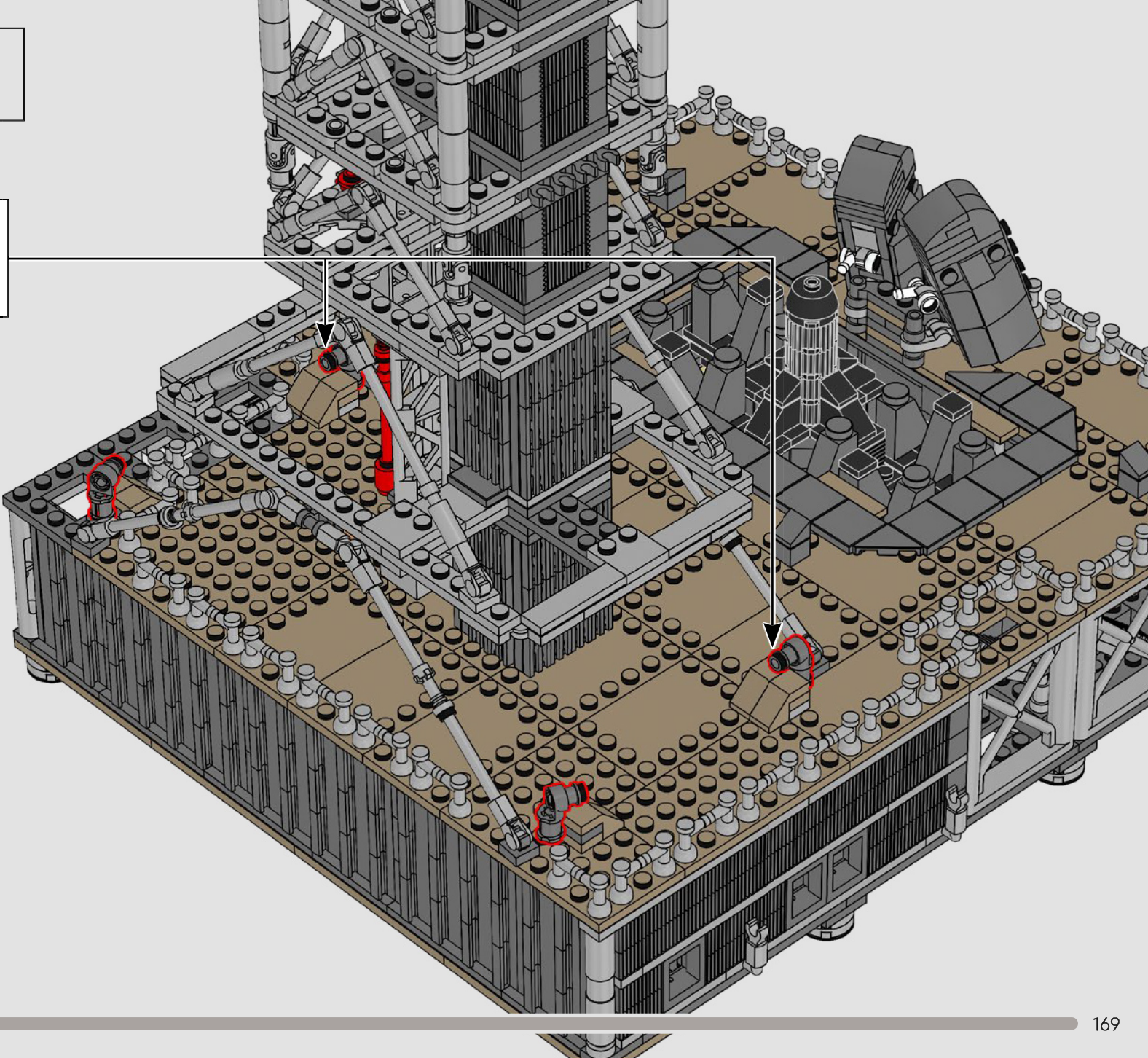
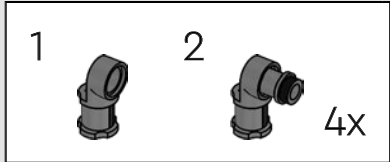

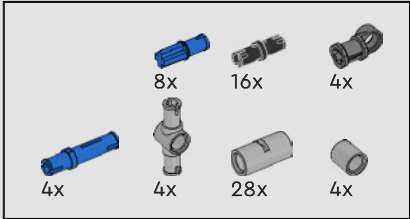
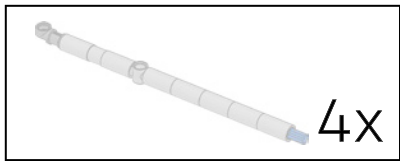

244

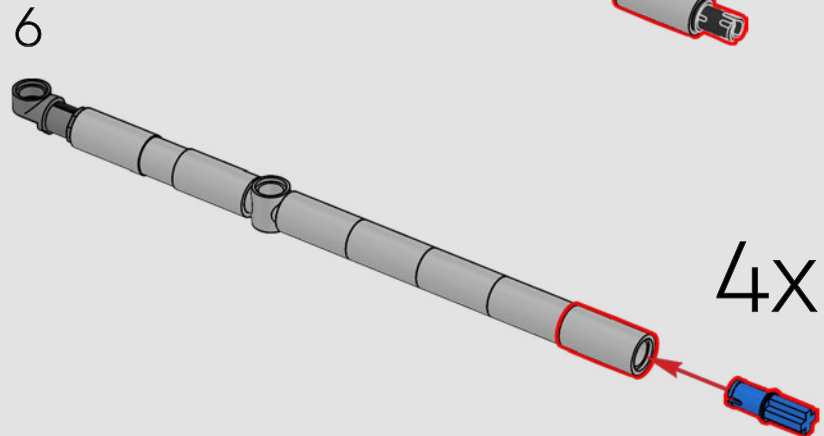
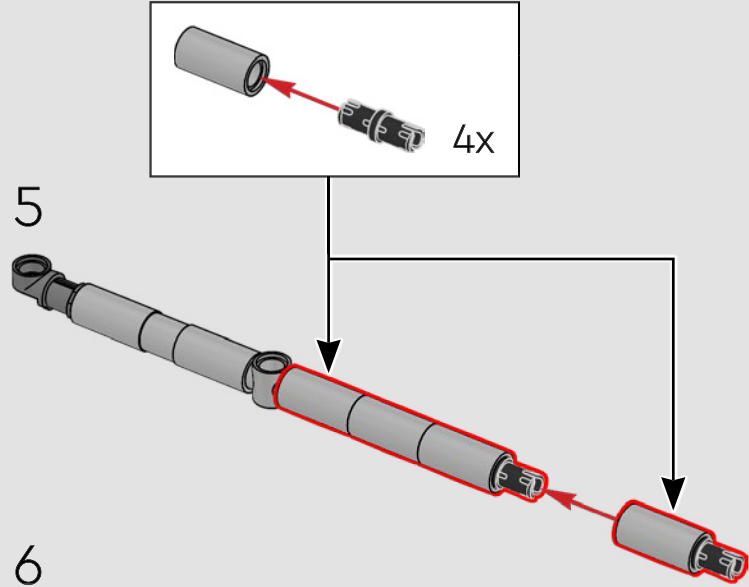
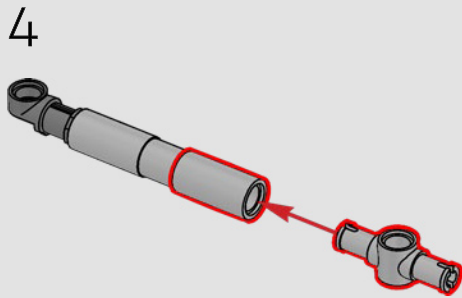
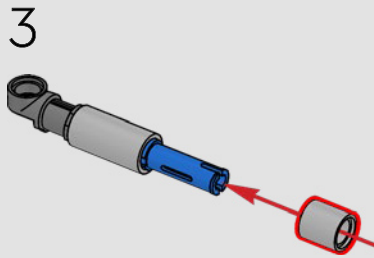
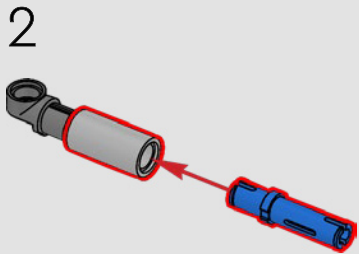
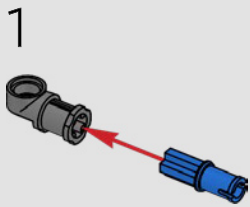

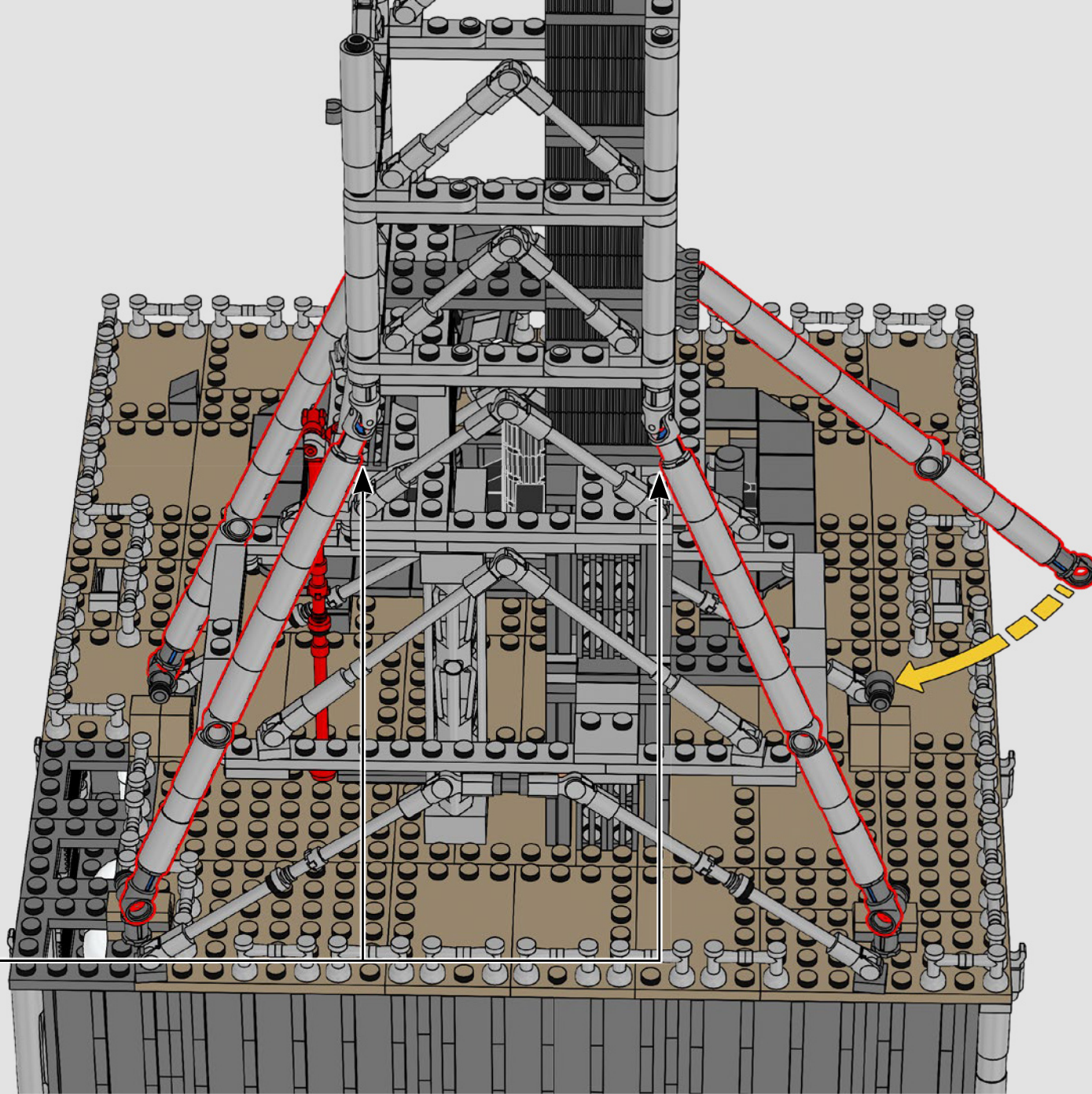

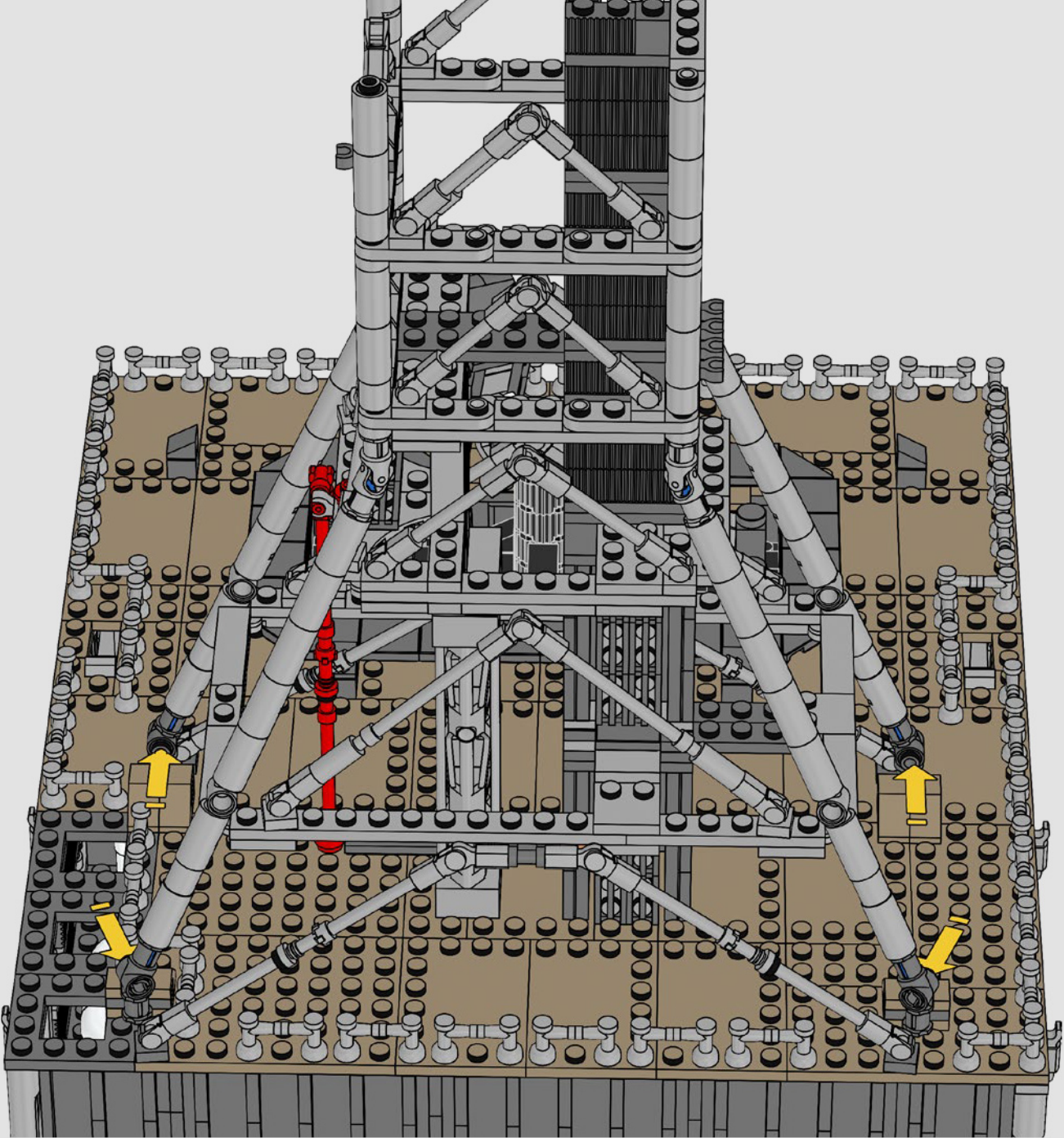

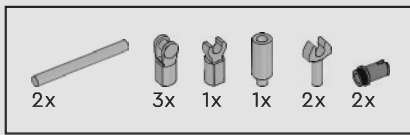

246

1

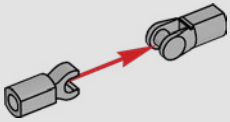

2

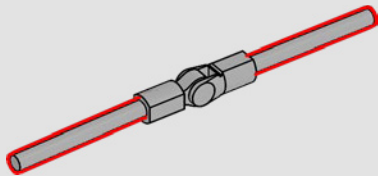

3

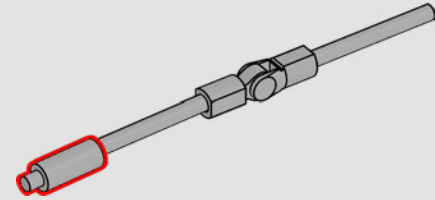

4

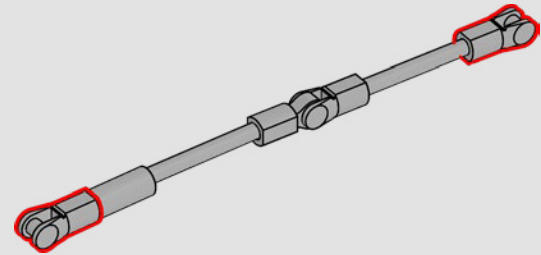

5

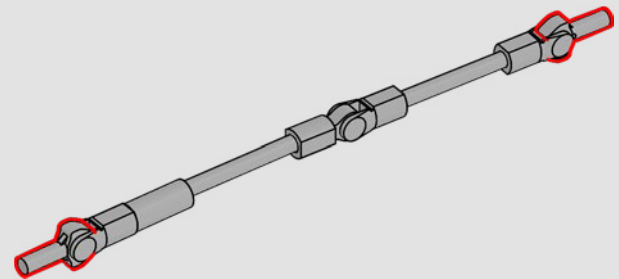

 2x

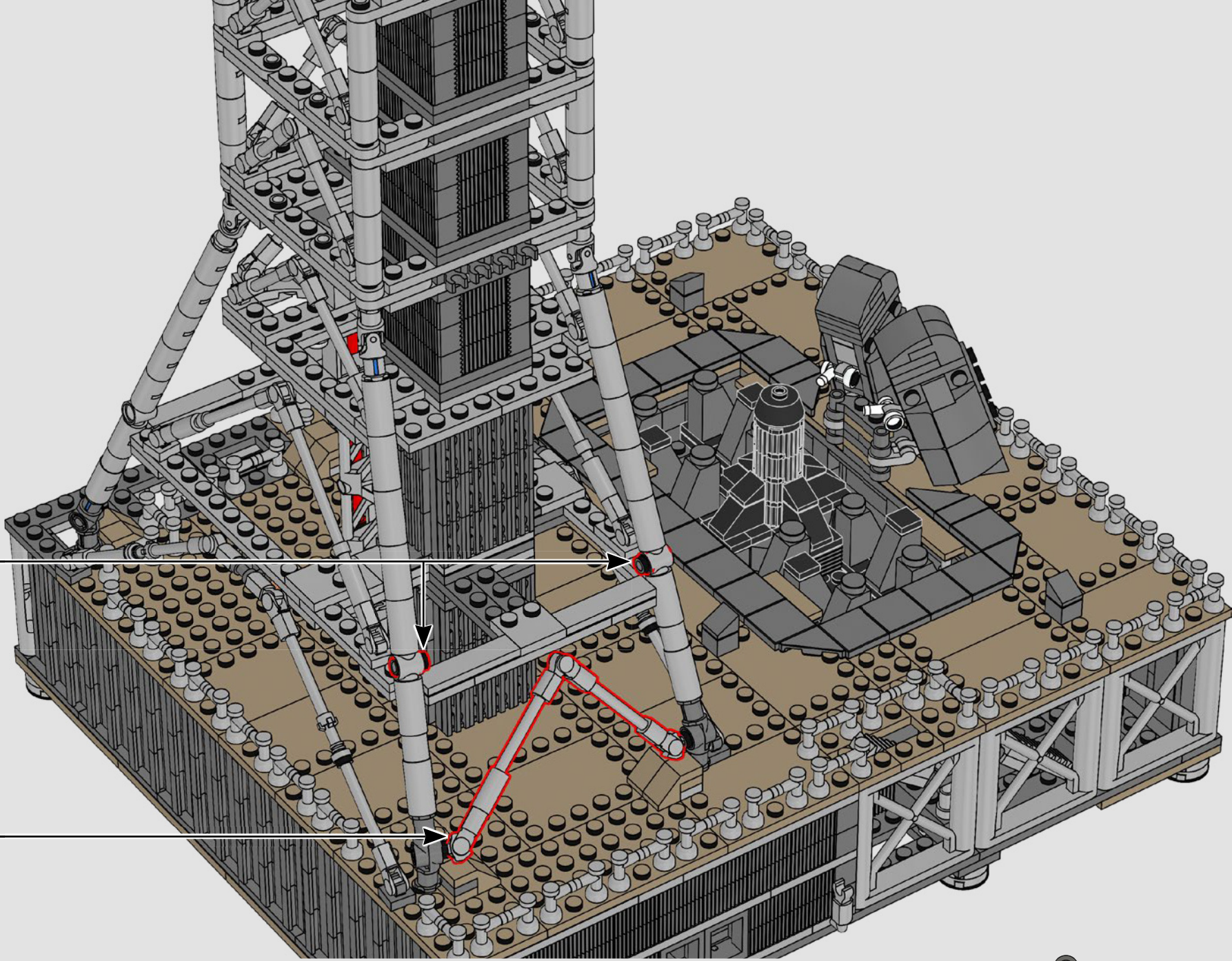

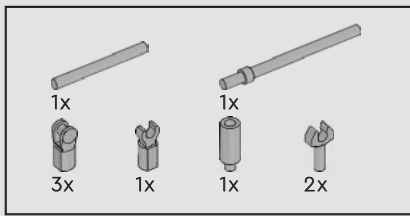

247

1

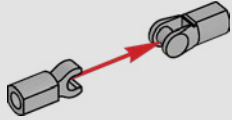

2

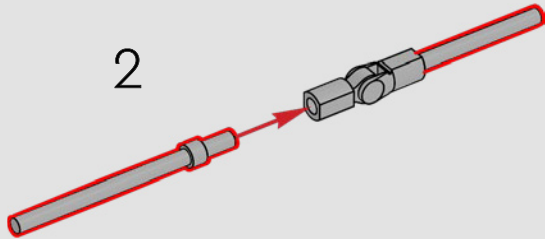

3

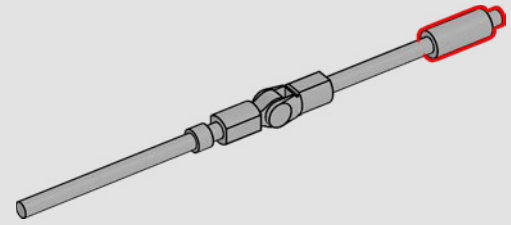

4

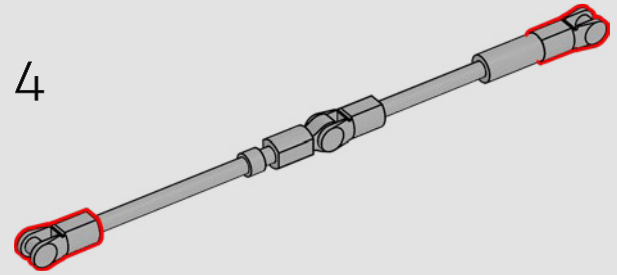

5

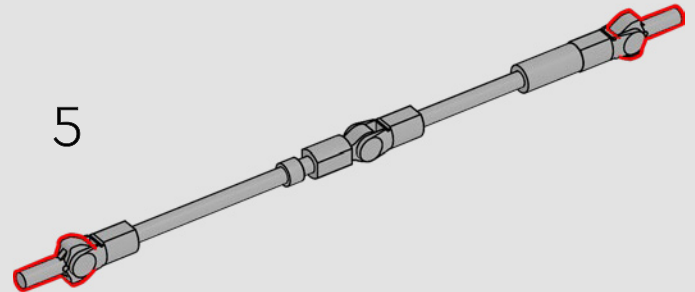

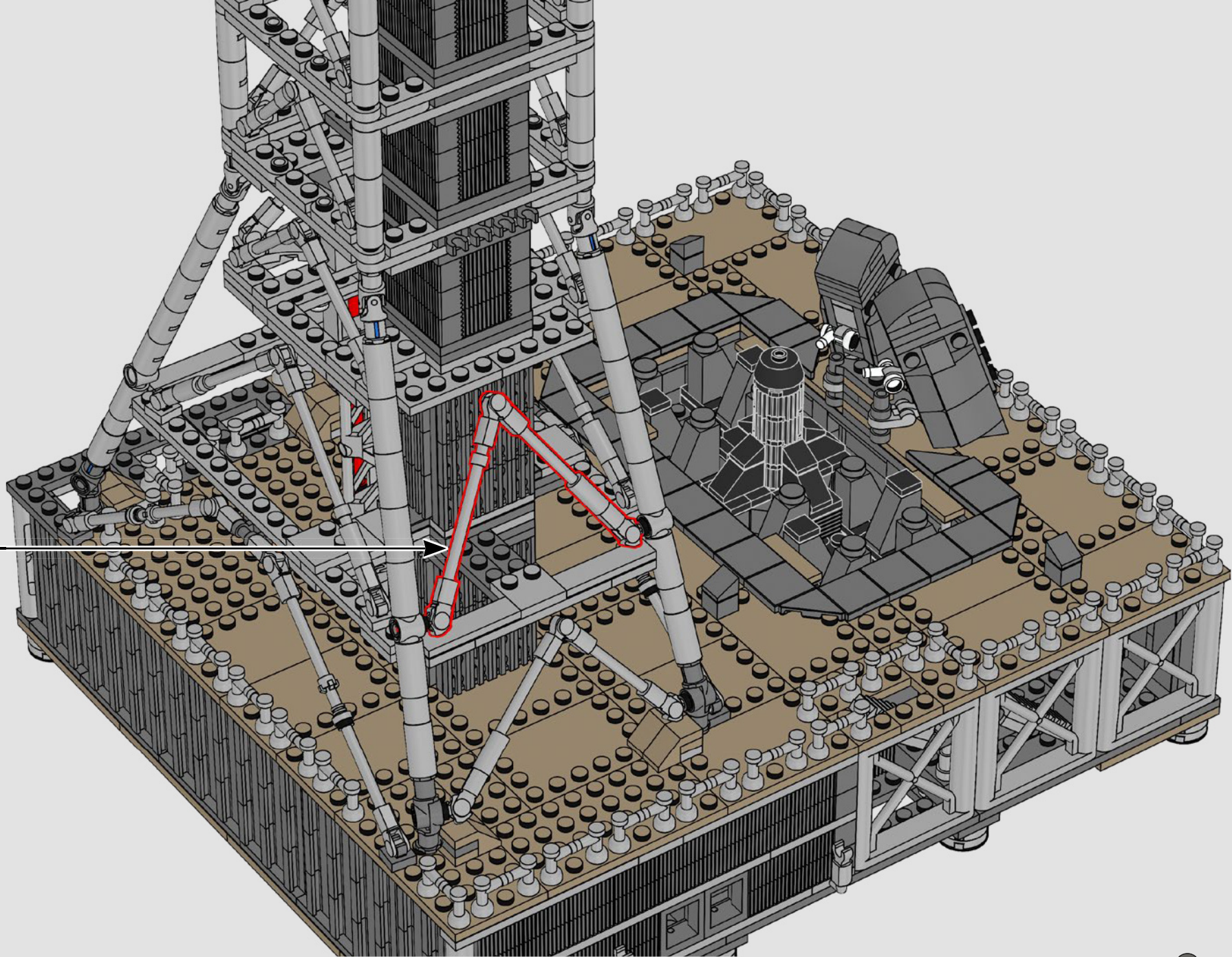



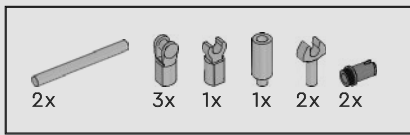

248

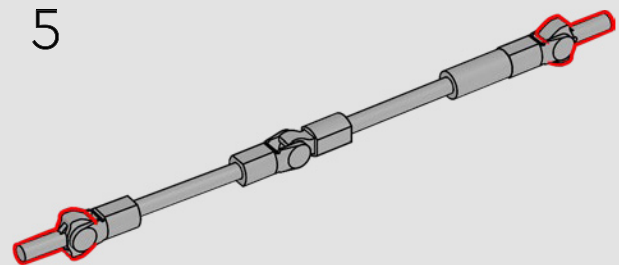
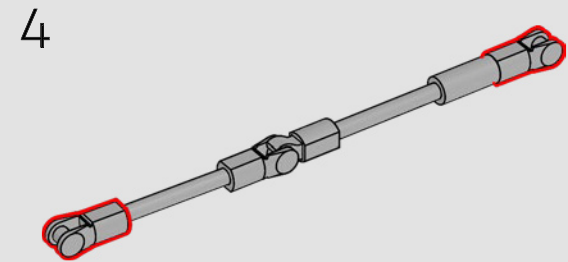
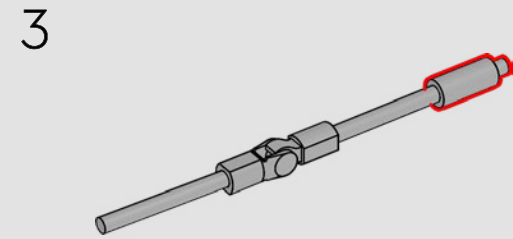
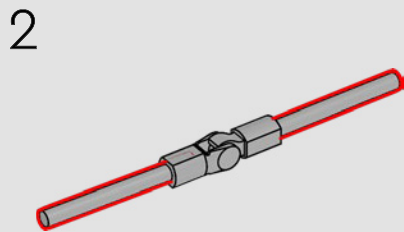
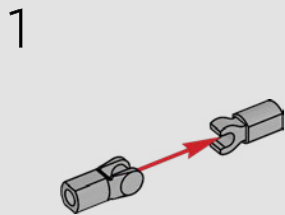

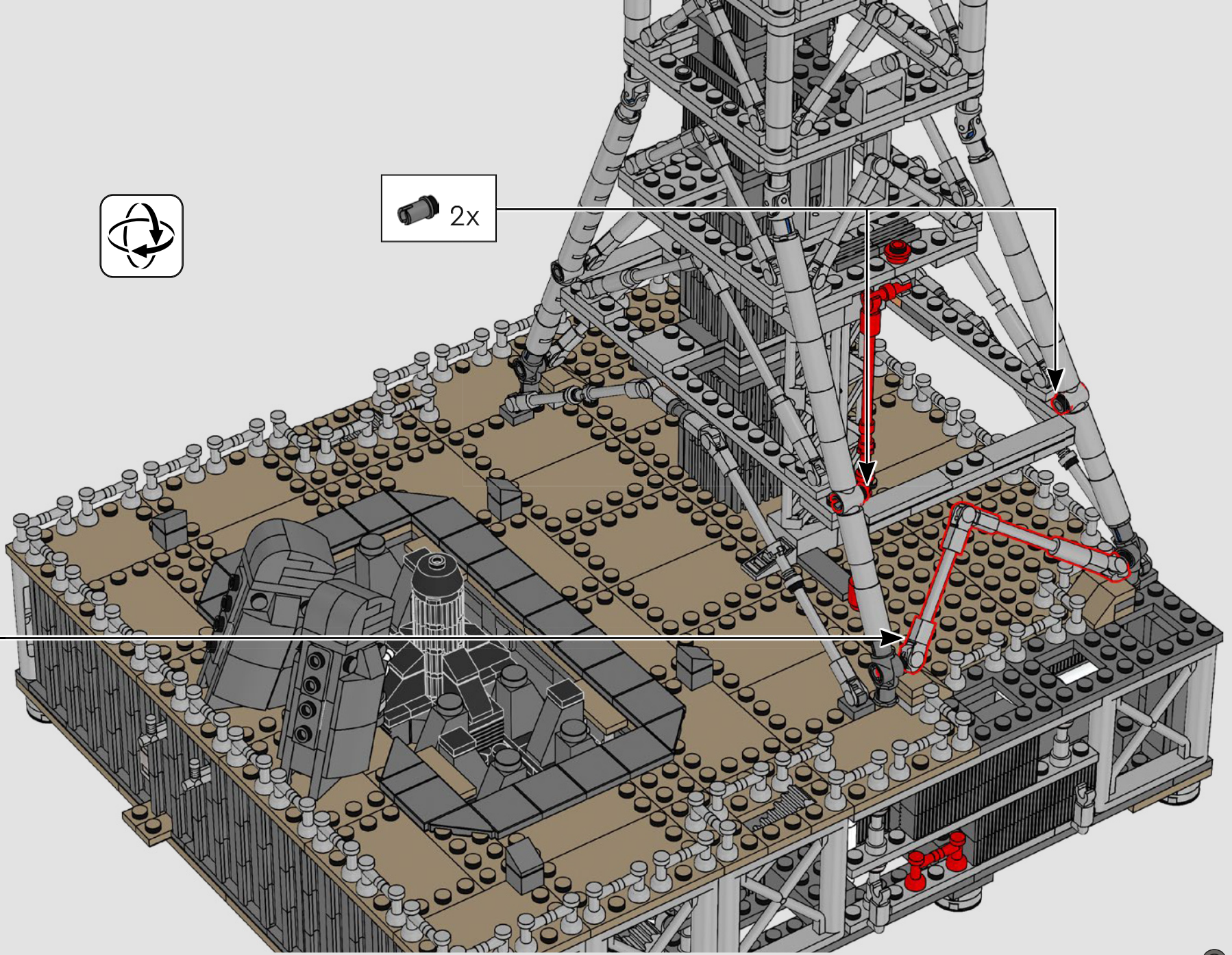

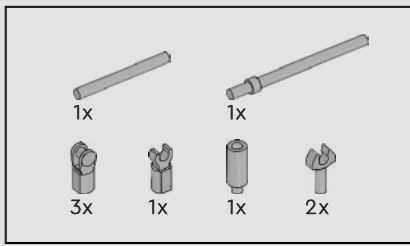

249

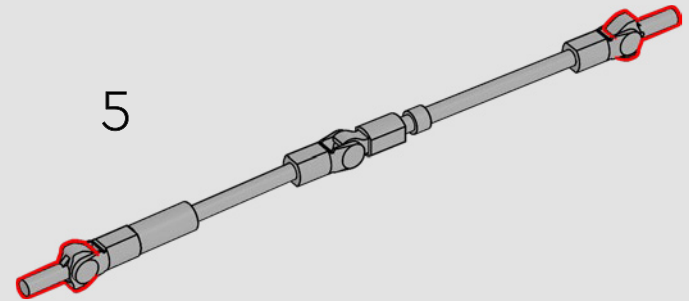
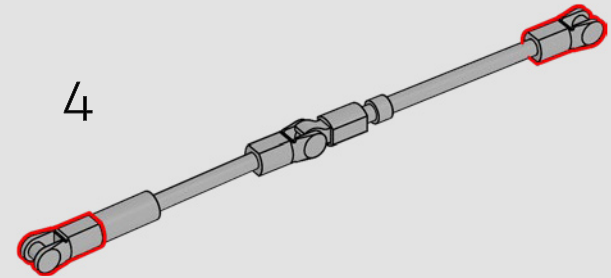
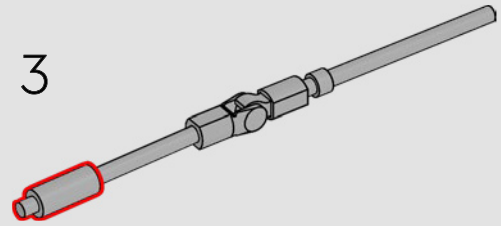
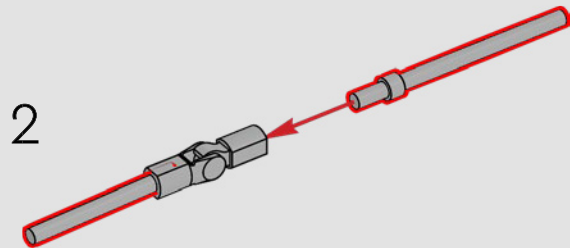
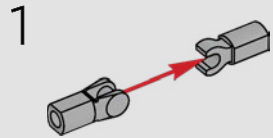

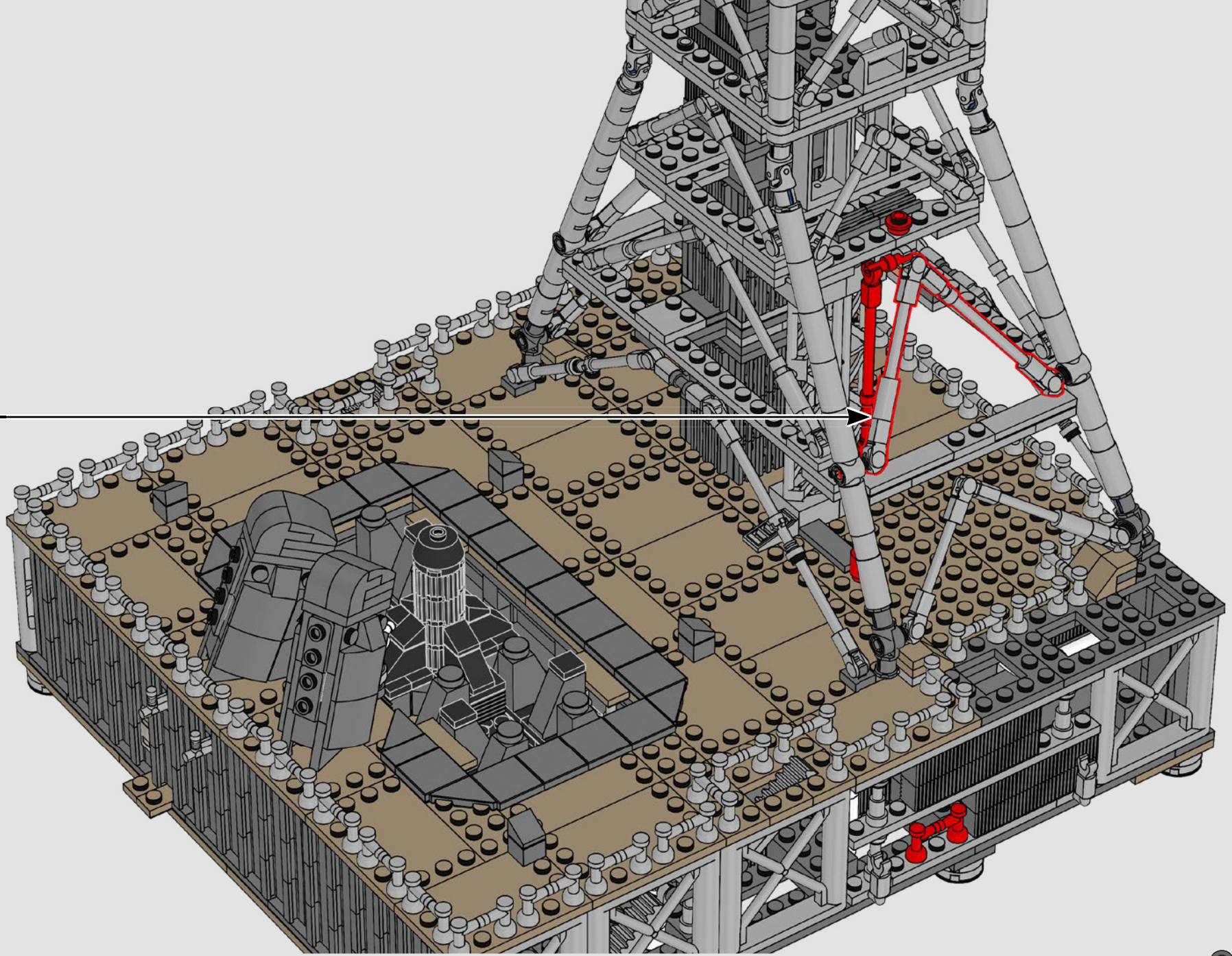

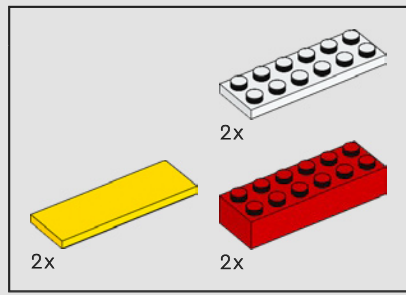

250

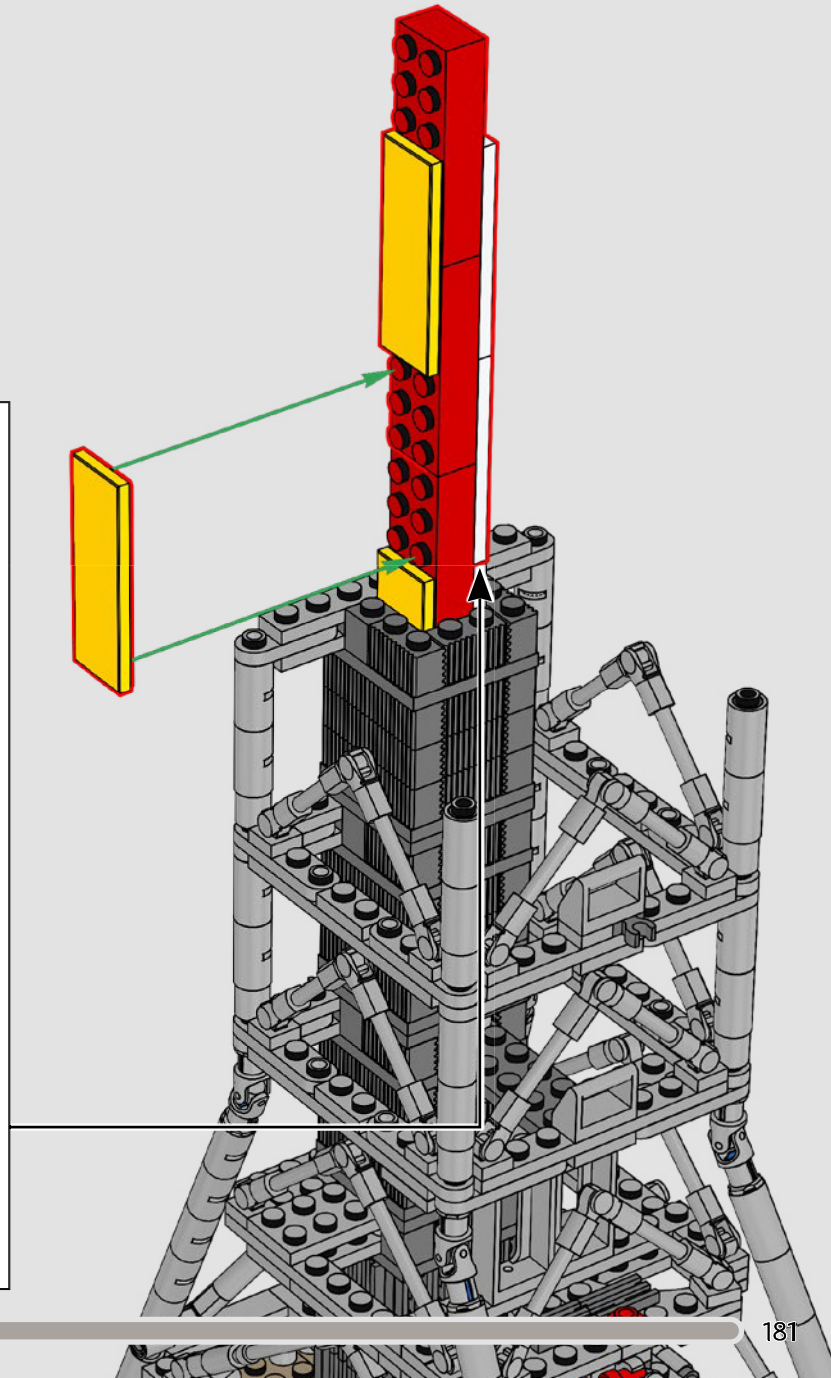
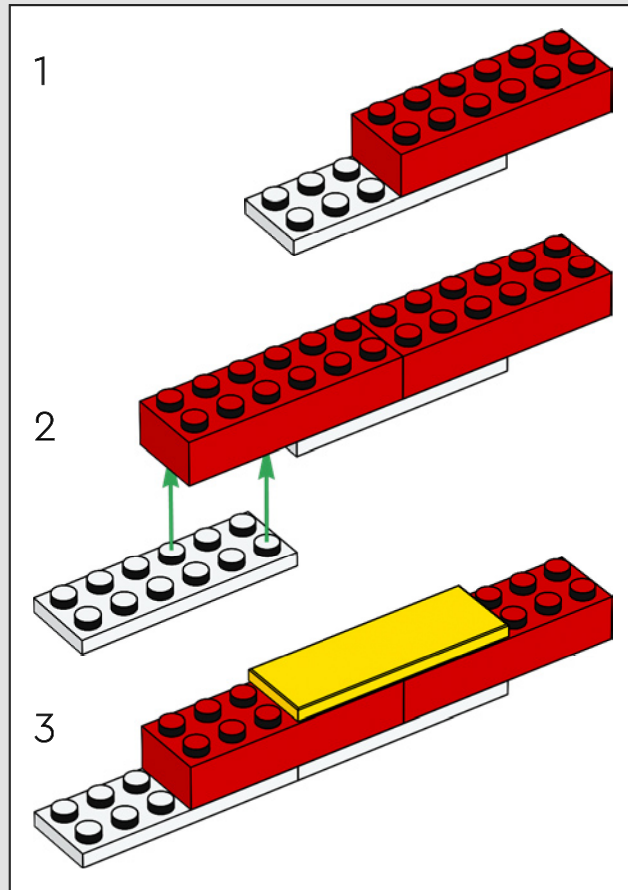

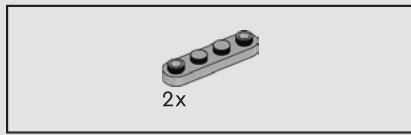
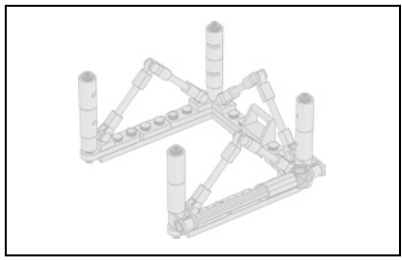

253

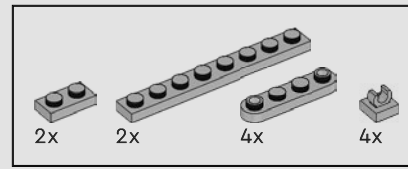
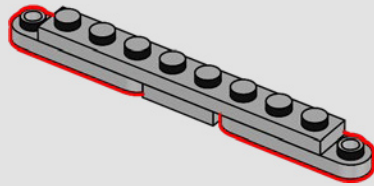

255

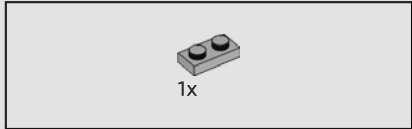
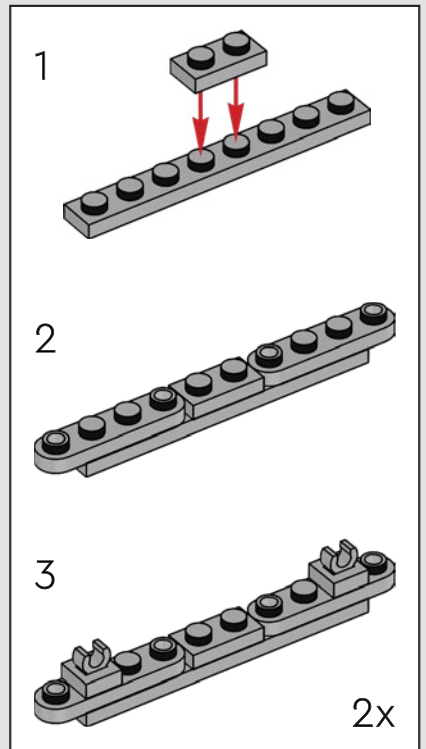

251

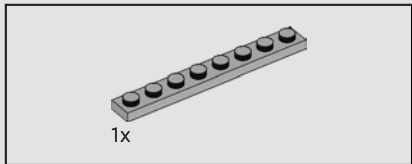
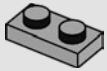

252

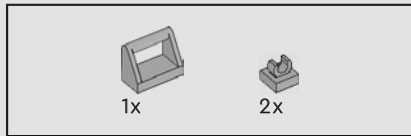
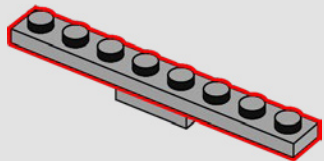

254

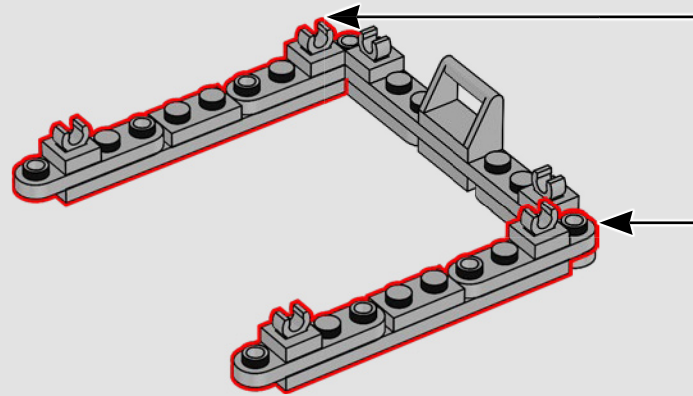
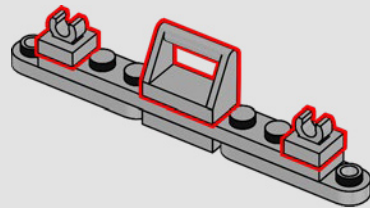

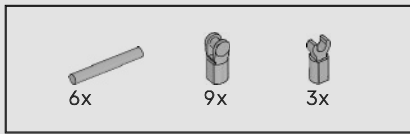

256

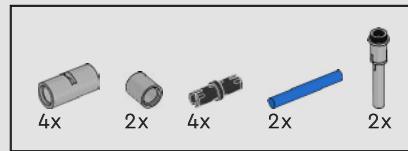
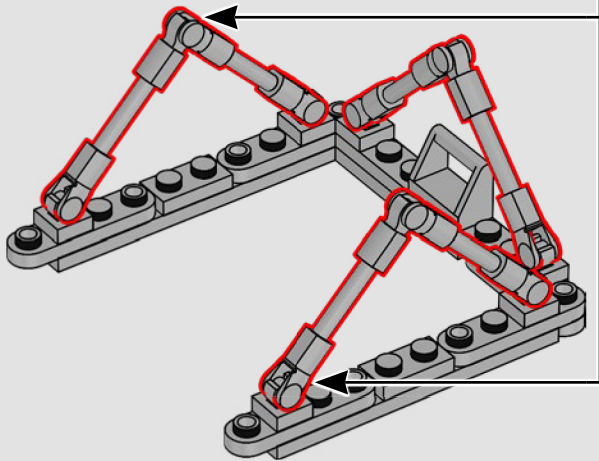
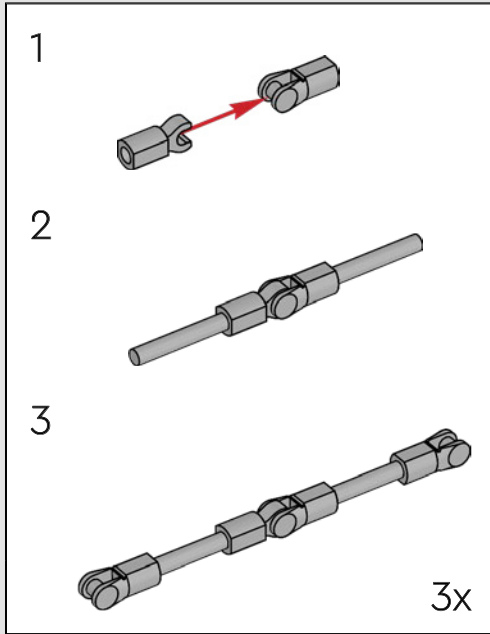

257

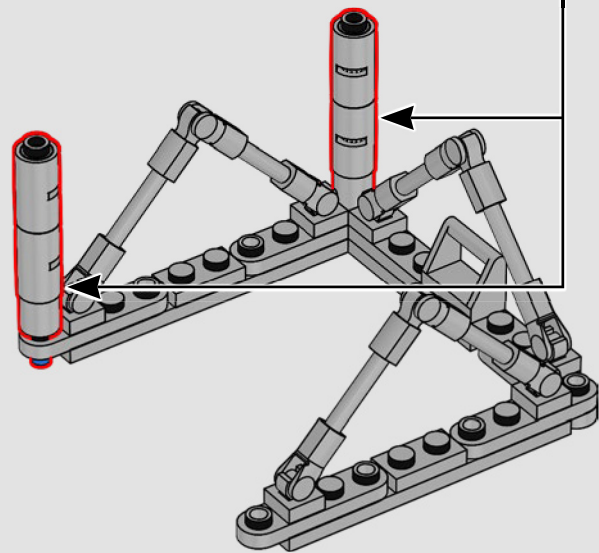
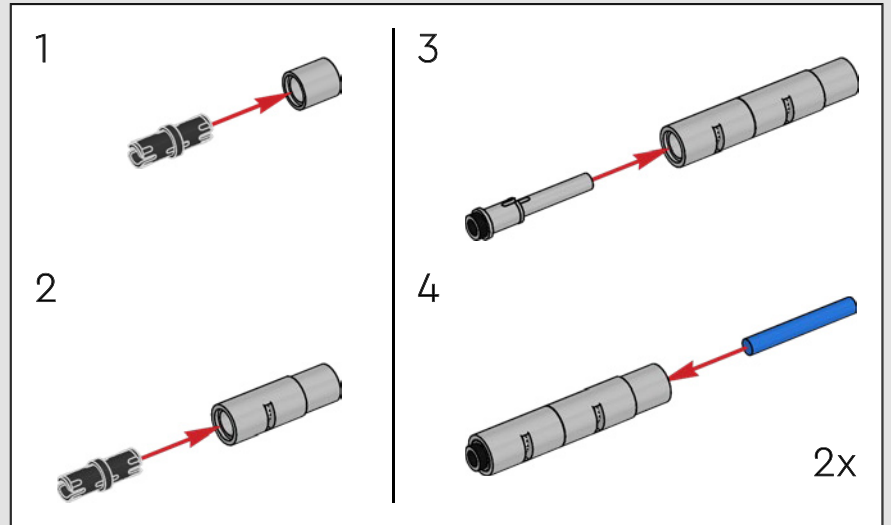

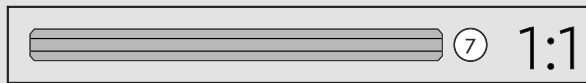
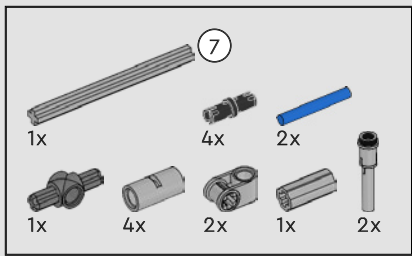

258

1

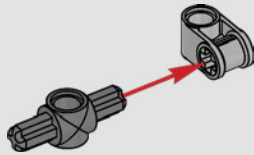

2

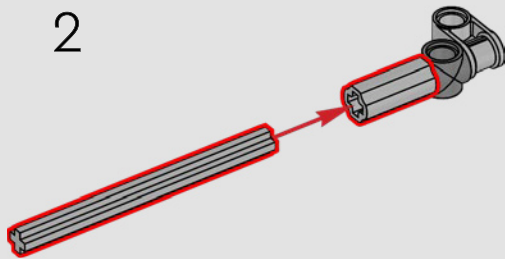

3

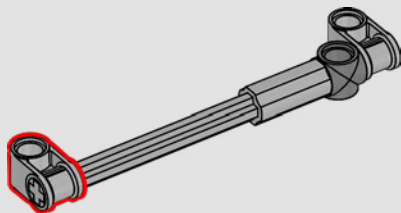

1

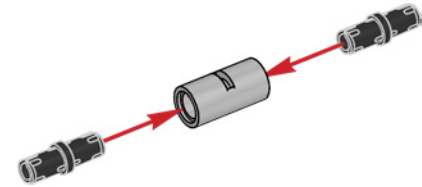

2

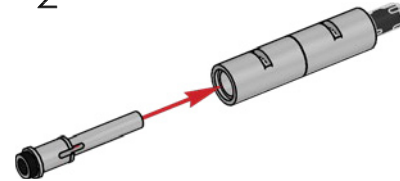

3

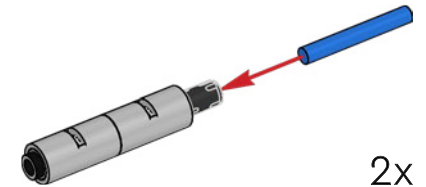

2x

4

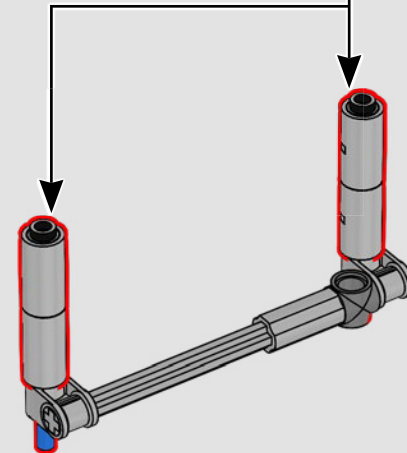



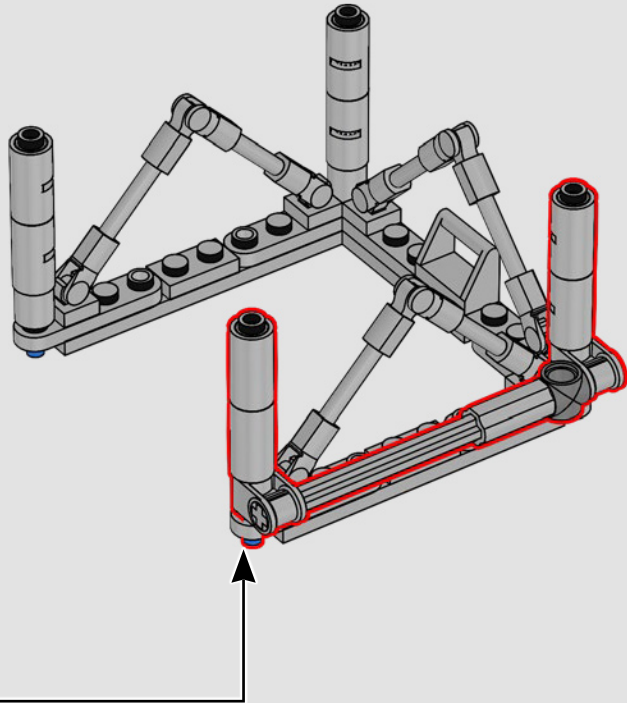

259

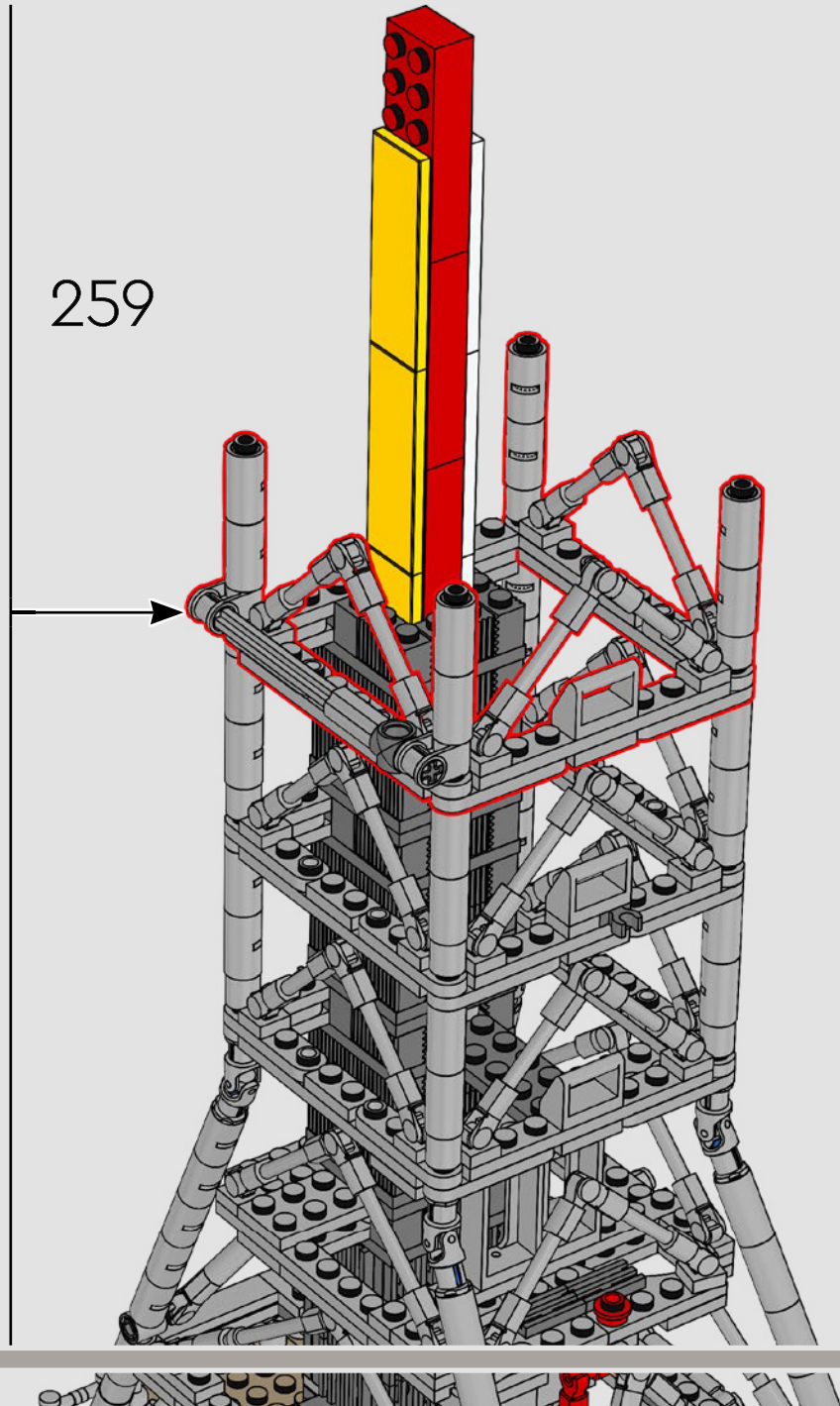

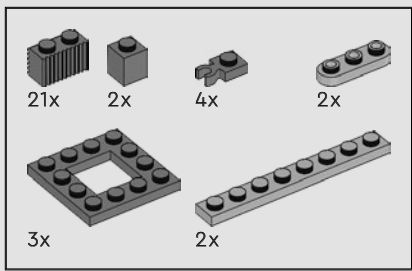

260

1

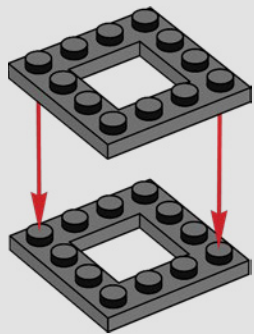

2

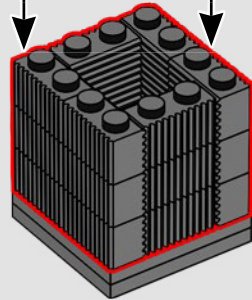

3

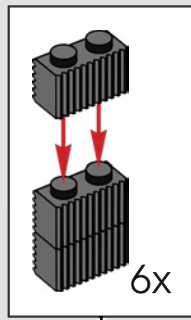
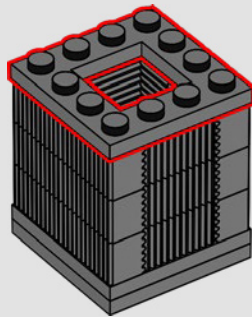

6x

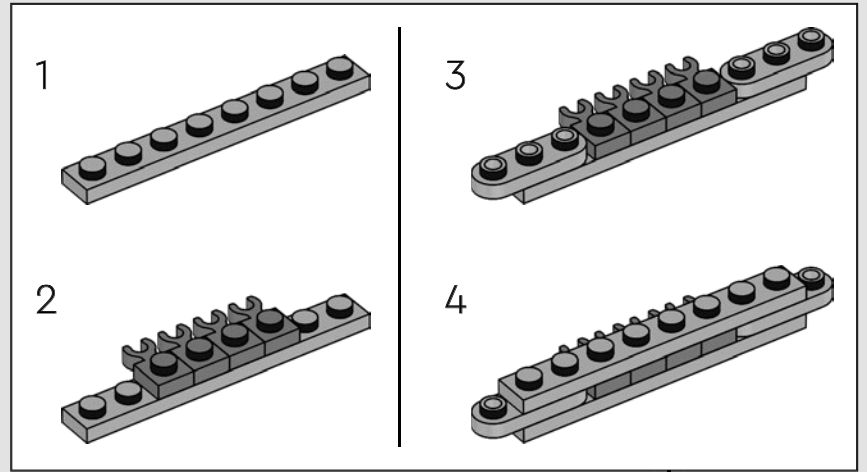

1

2

3

4

4

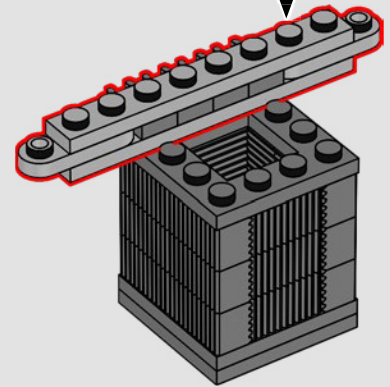

5

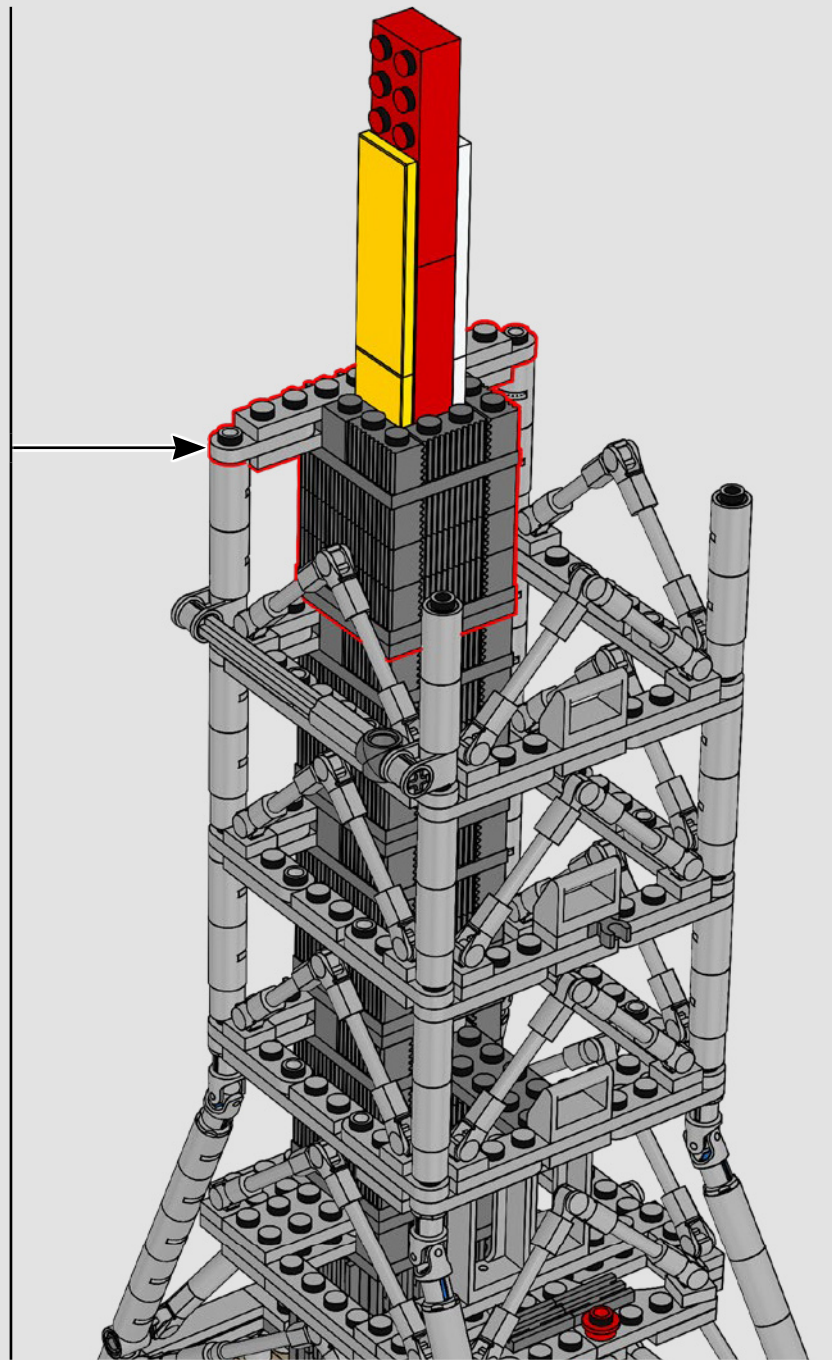
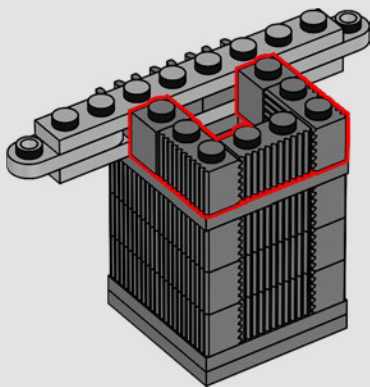

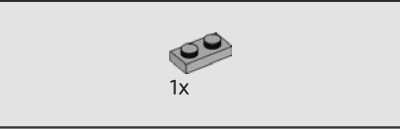
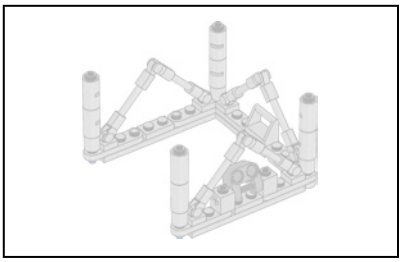

1x

261

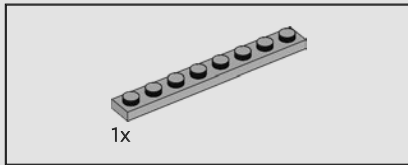
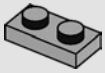

1x

262

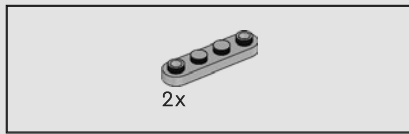
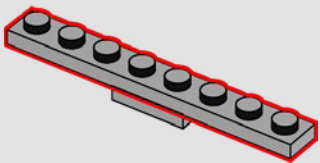

2x

263

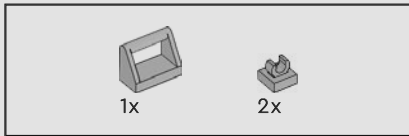
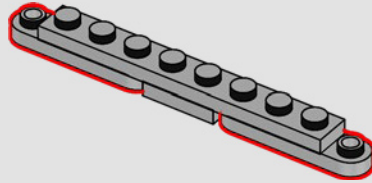

1x

2x

264

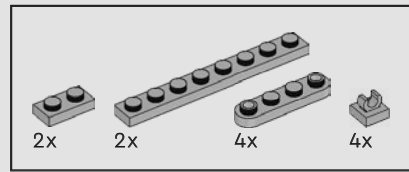
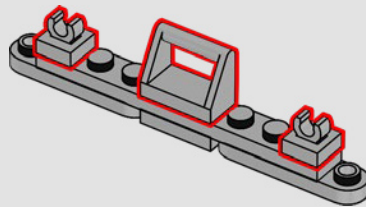

2x

2x

4x

4x

265

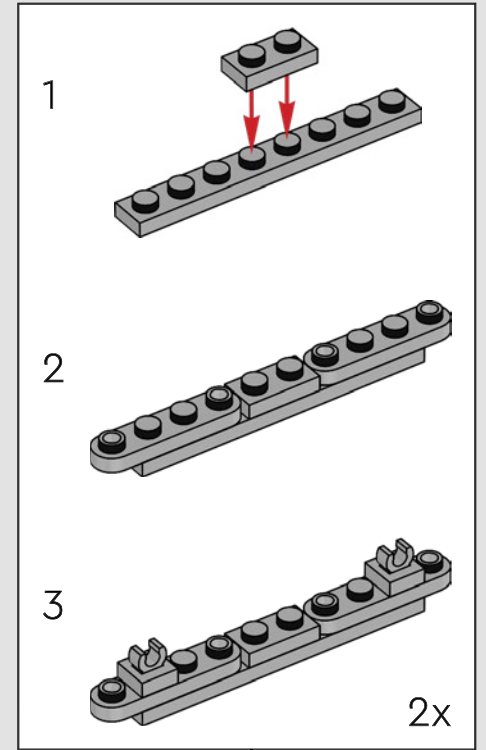

1

2

3

2x

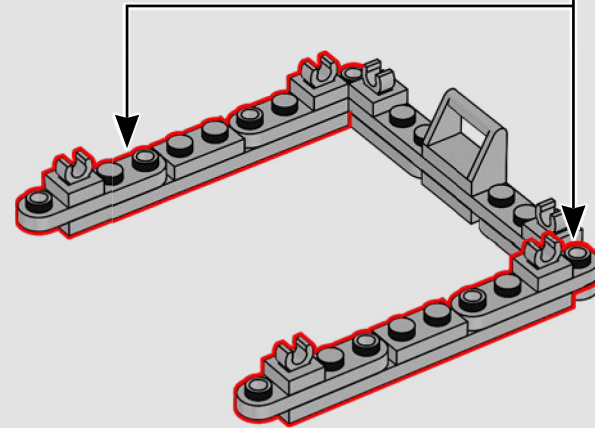

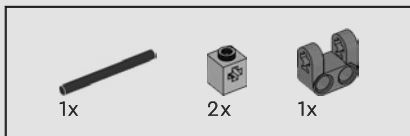

266

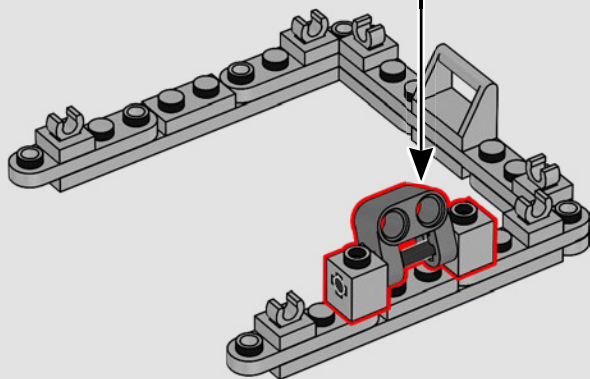
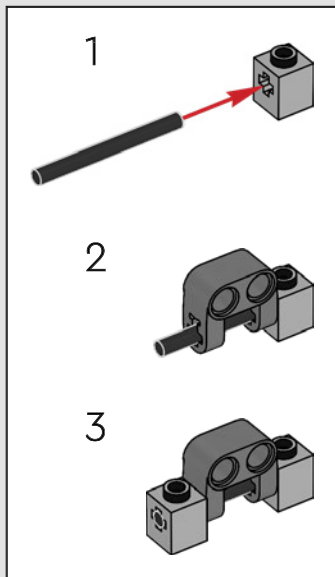

267

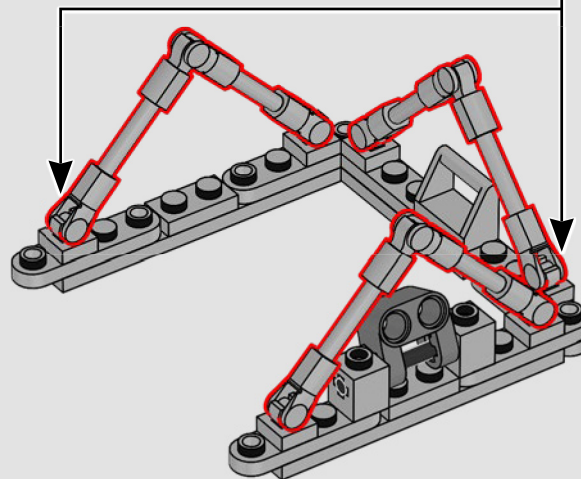
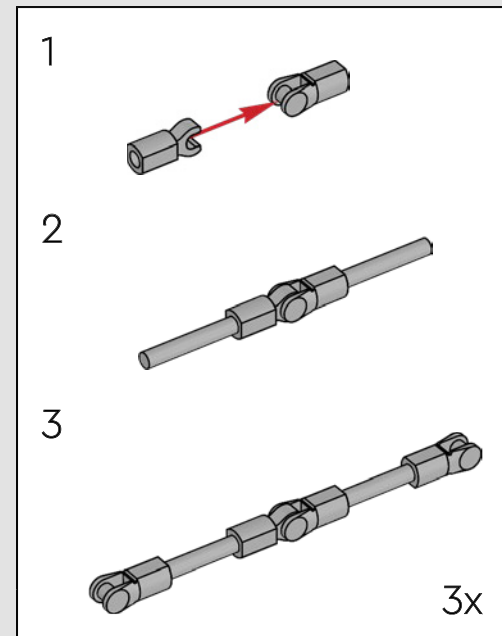

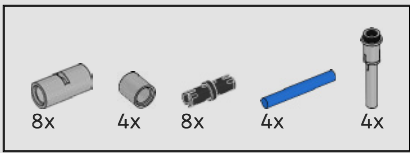

268

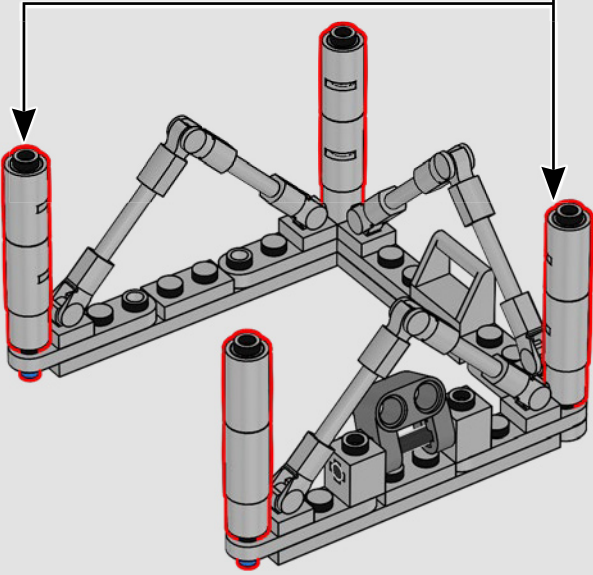
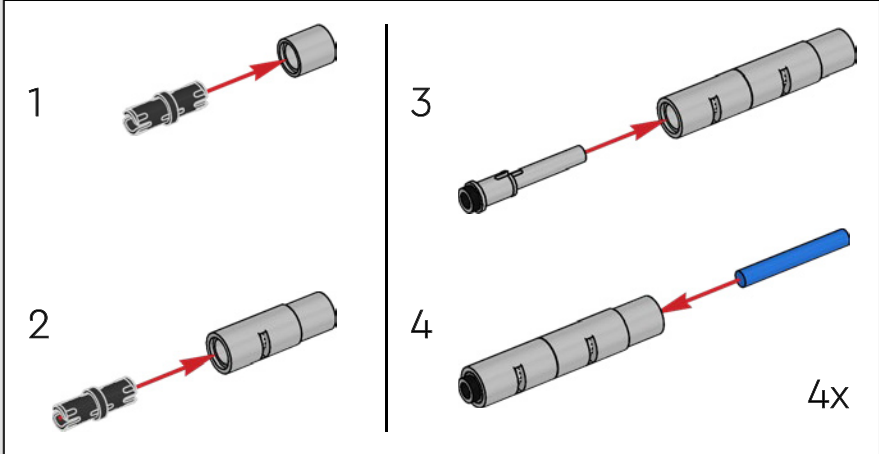

269

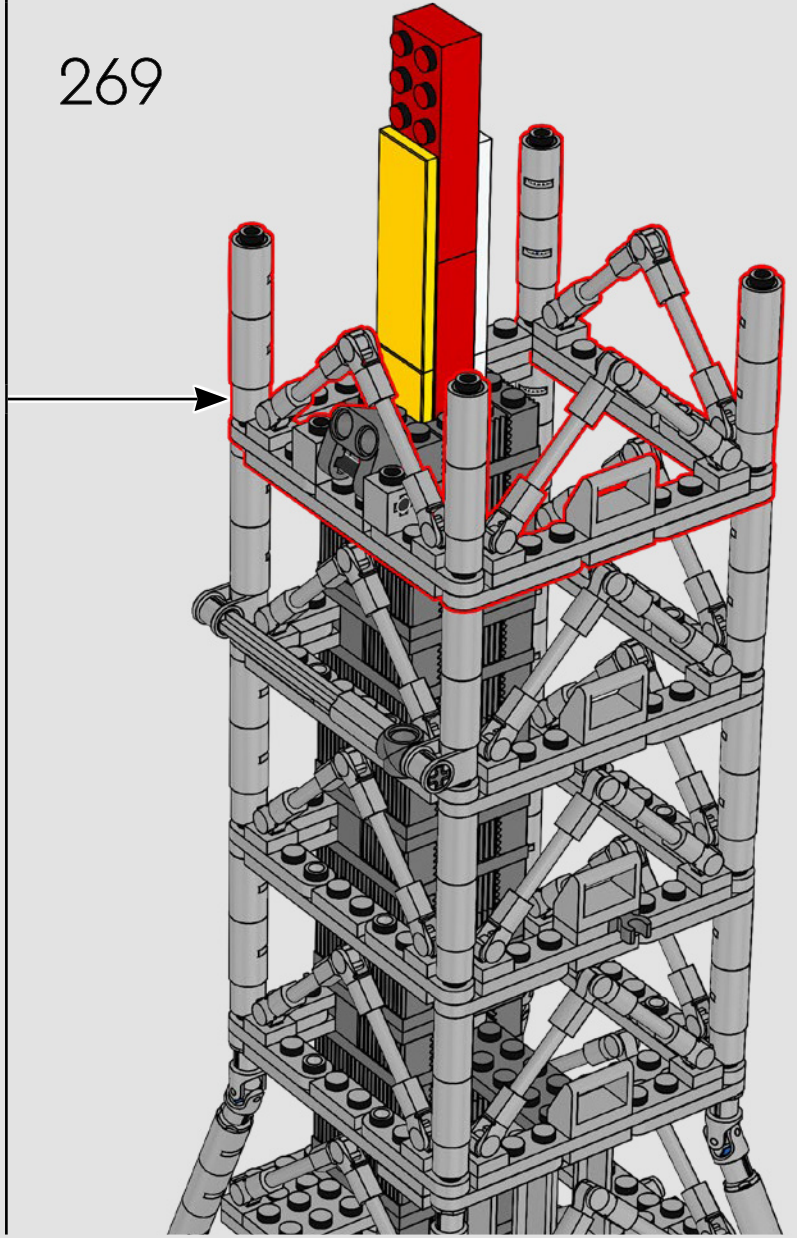

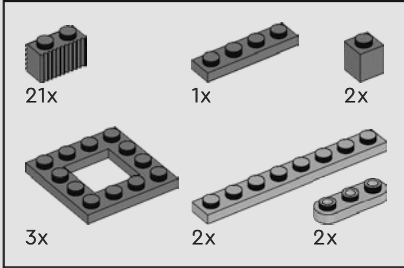
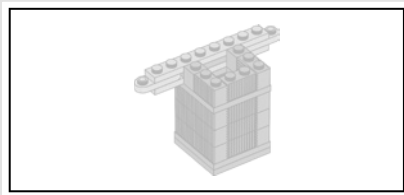

270

1

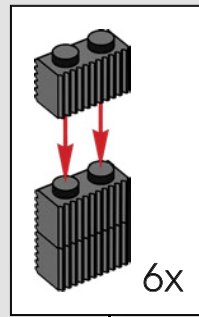
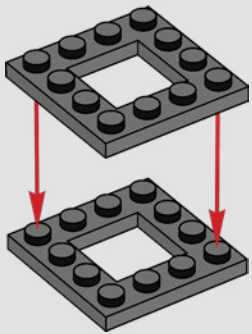

2

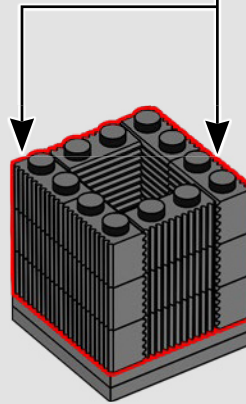

3

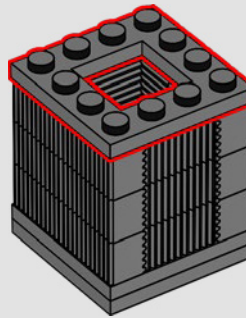

1

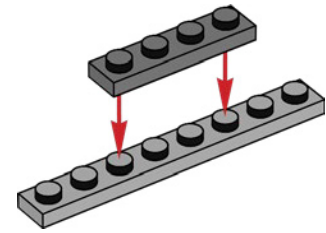

2

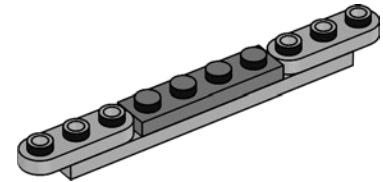

3

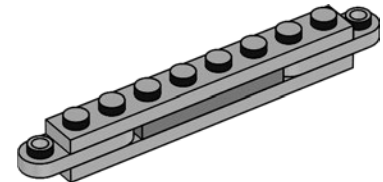

4

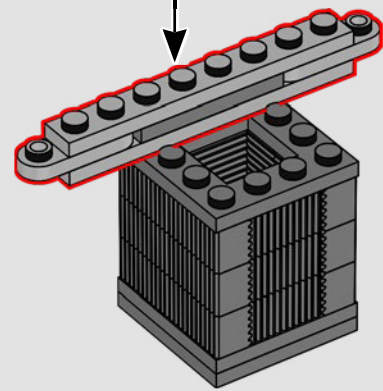

5

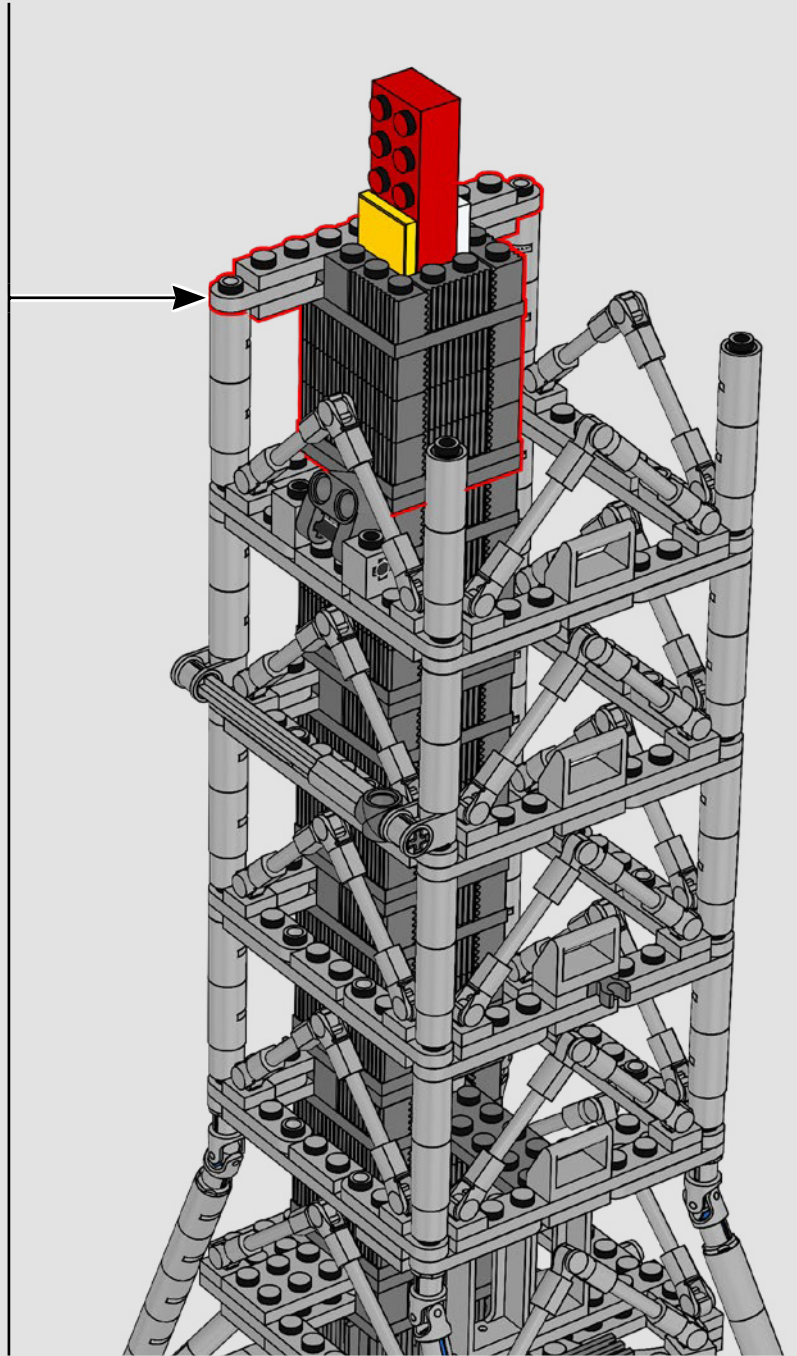
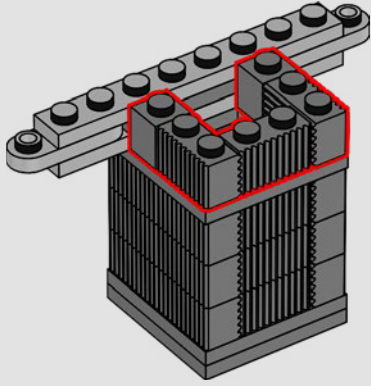



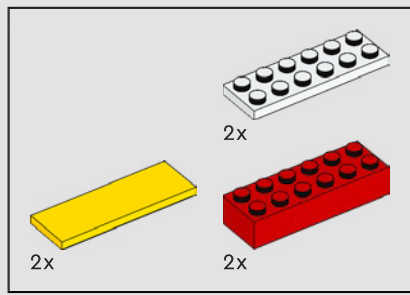
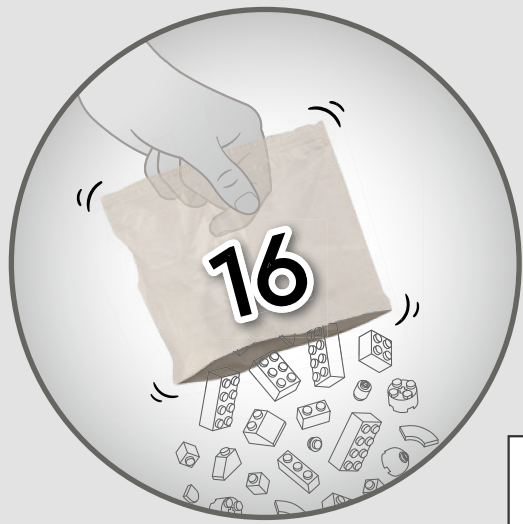

271

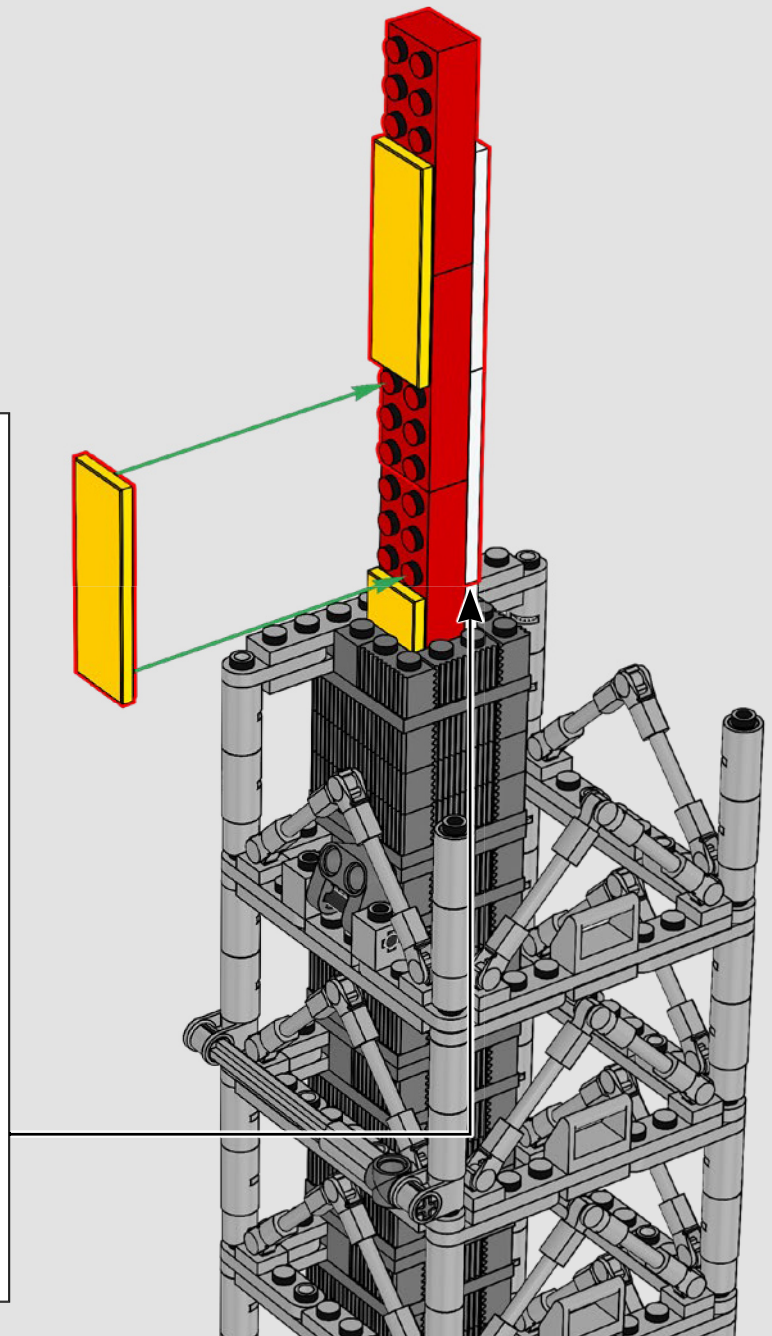
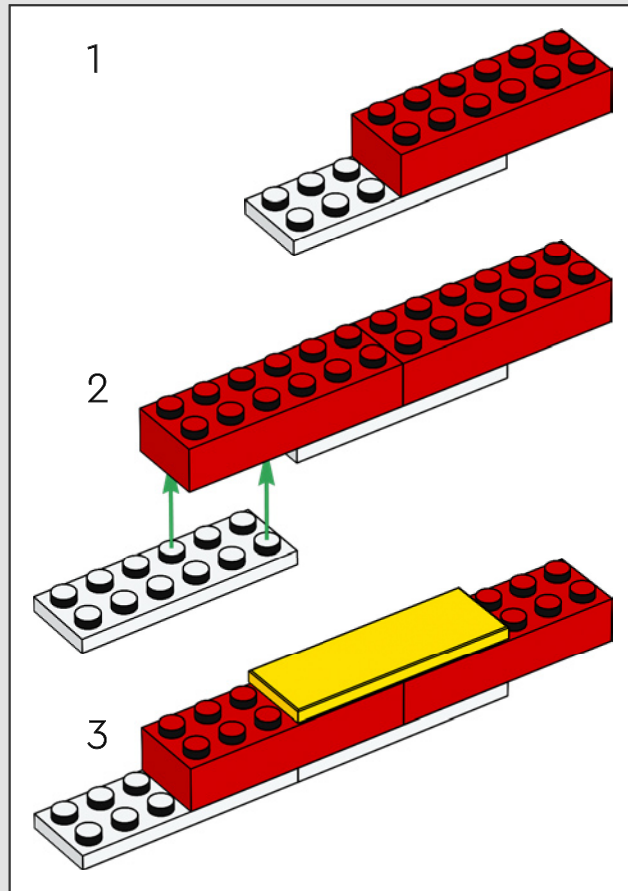

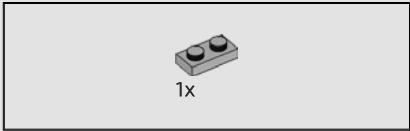
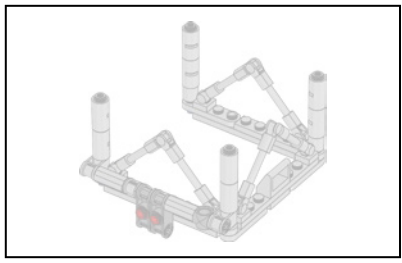

272

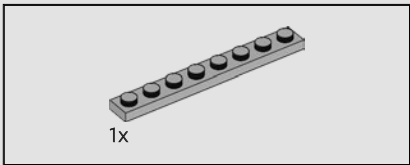
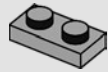

273

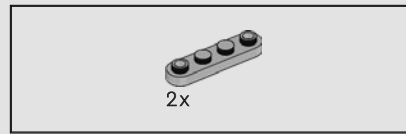
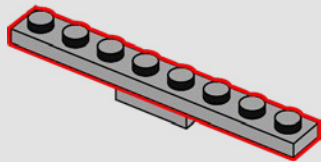

274

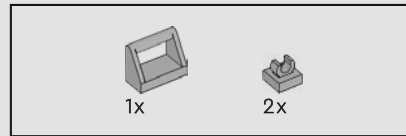
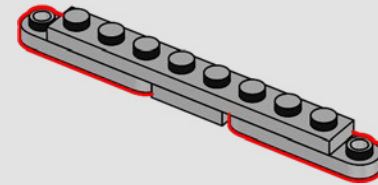

275

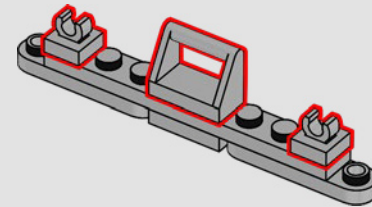

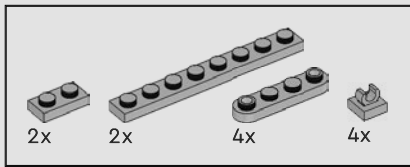

276

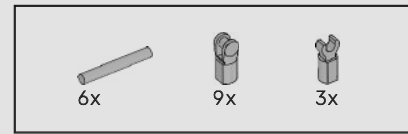
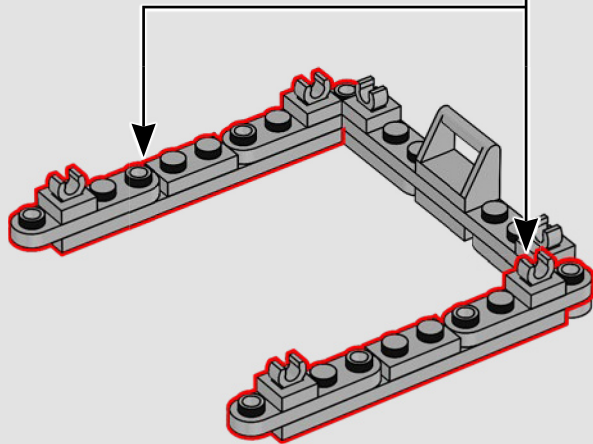
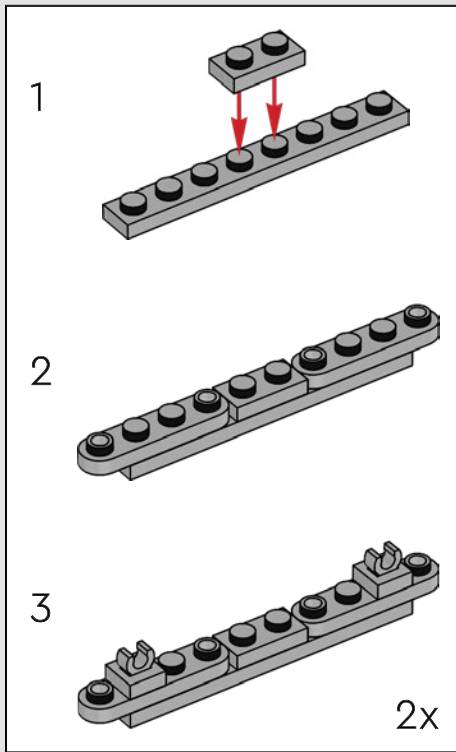

277

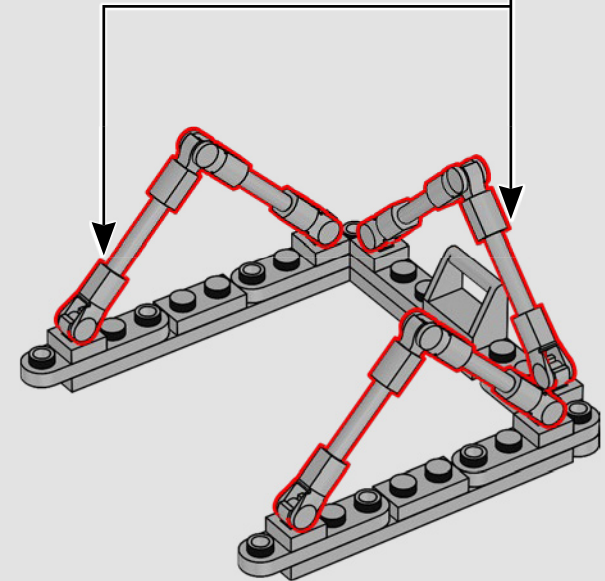
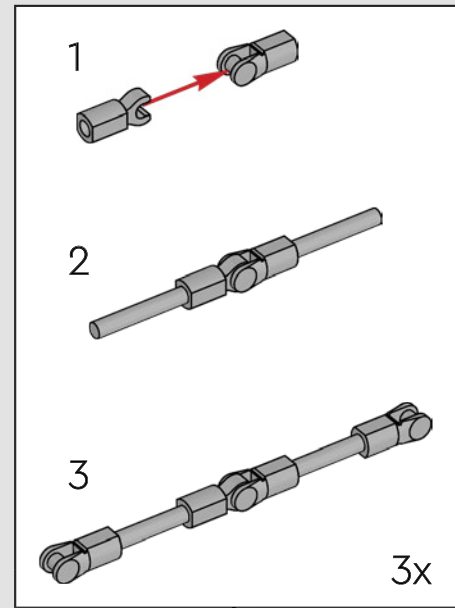

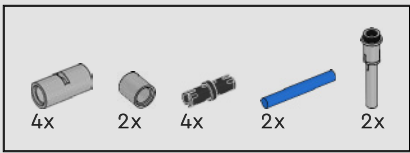

278

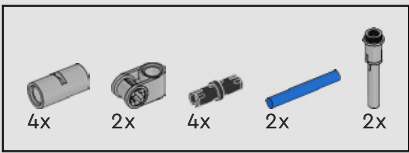
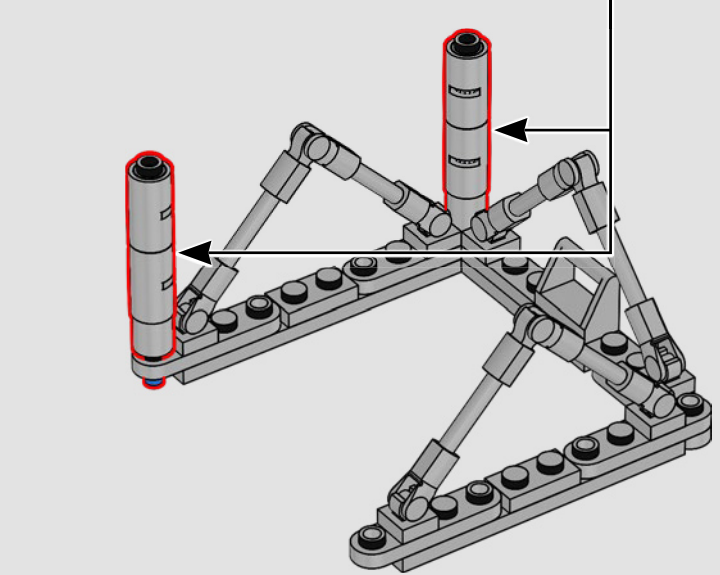
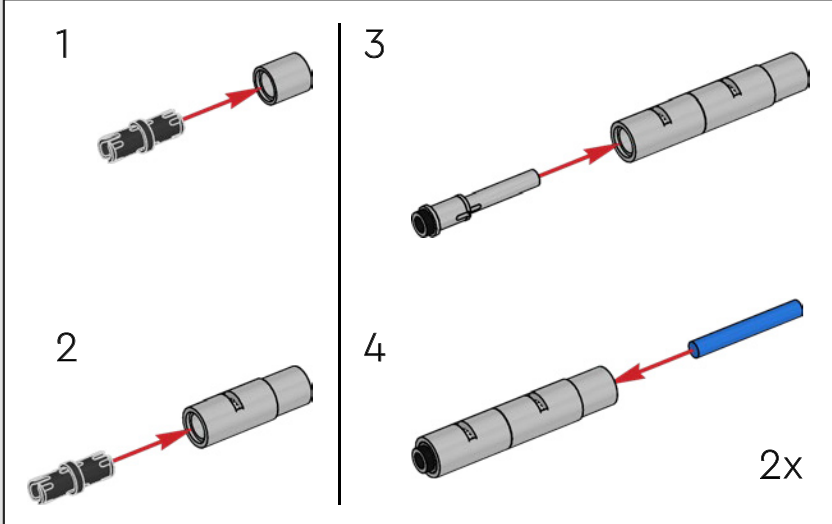

279

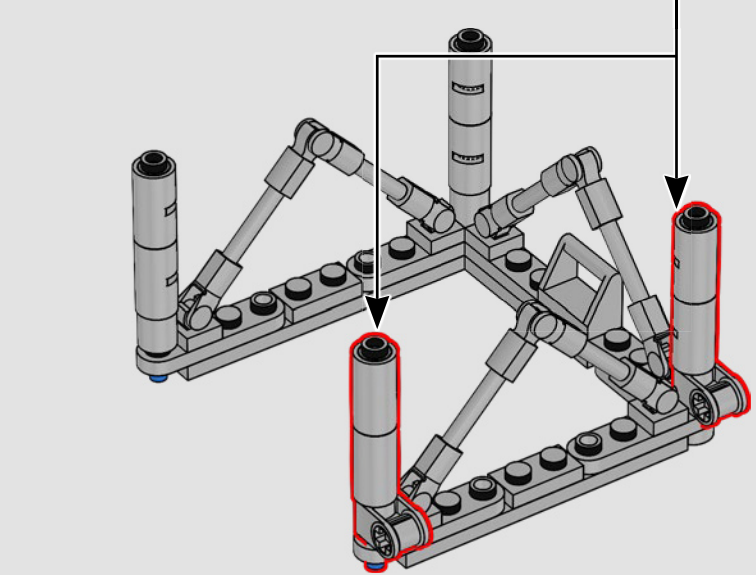
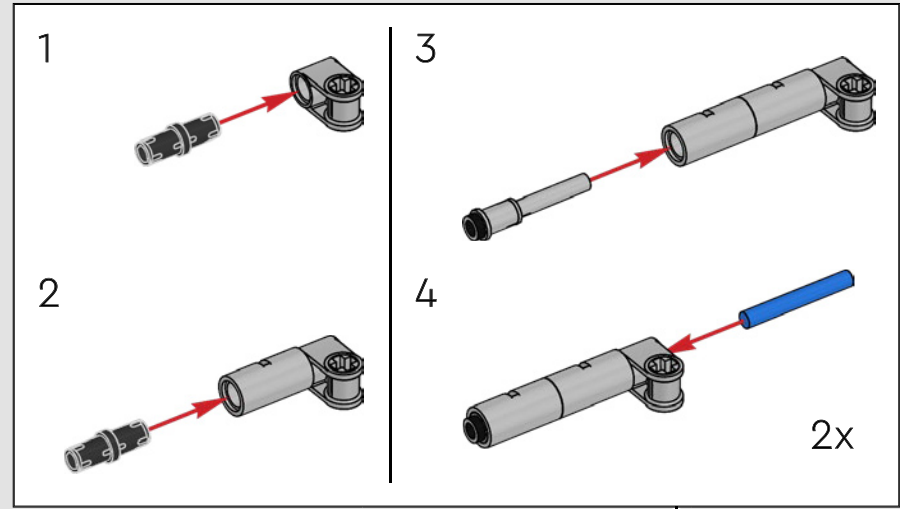

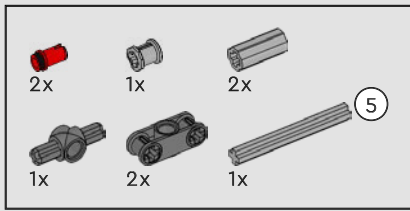

280

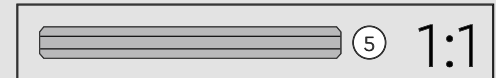
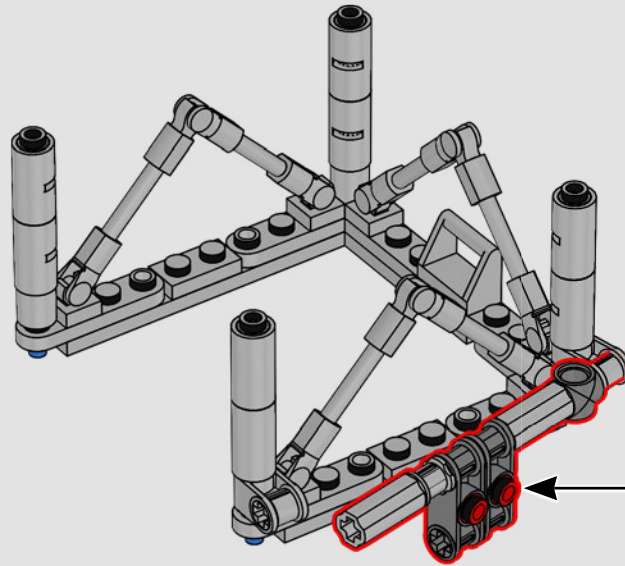
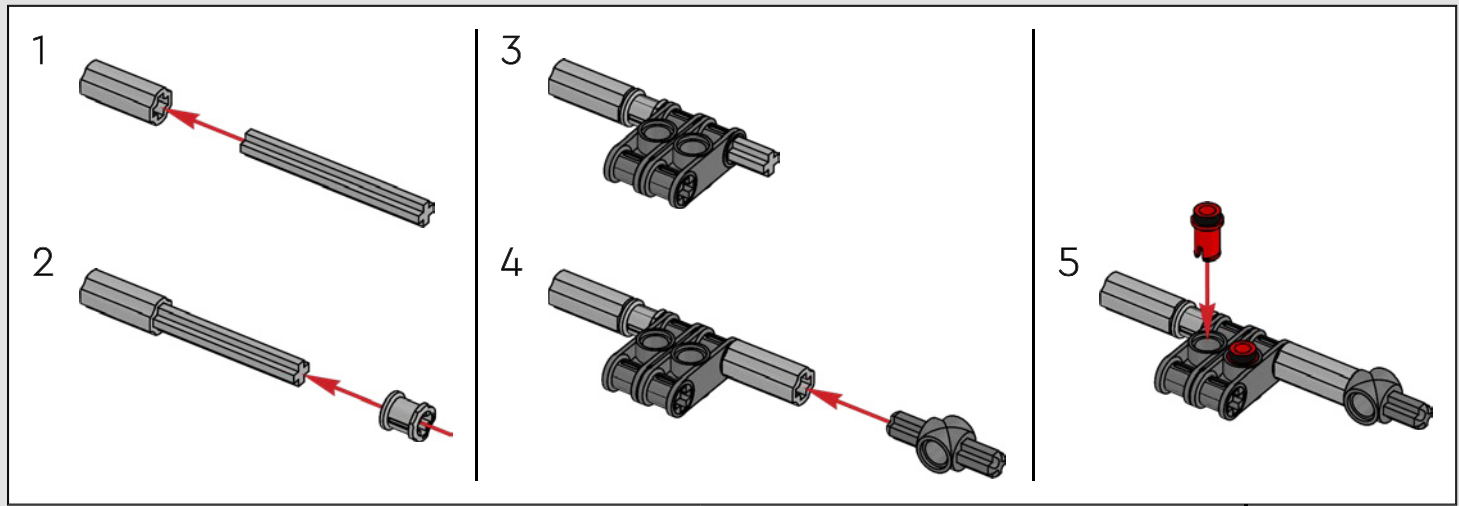

1x

281

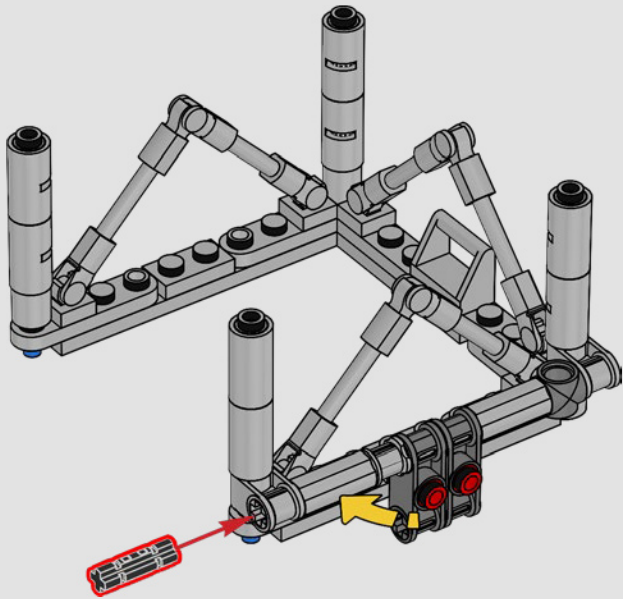

282

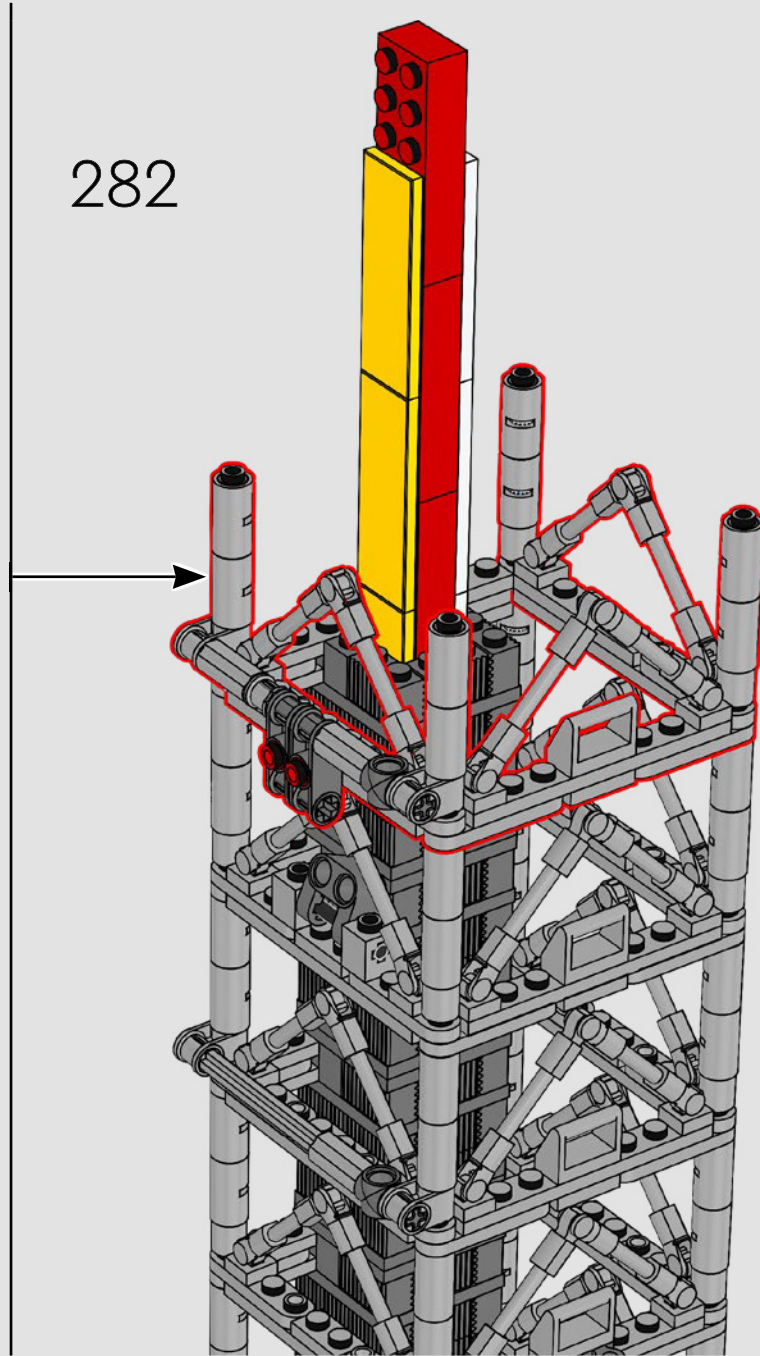

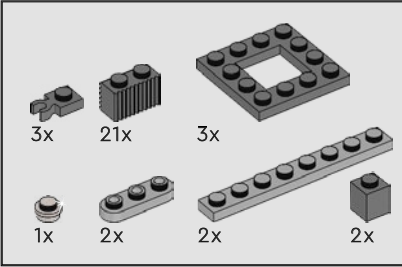
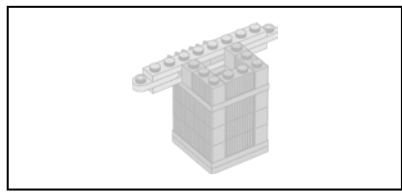

283

1

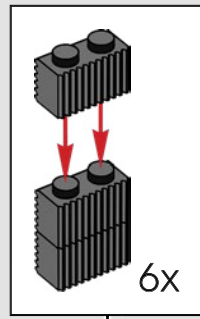
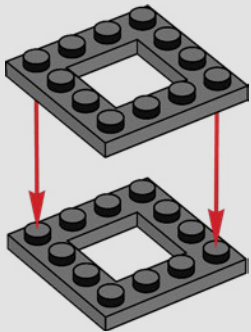

2

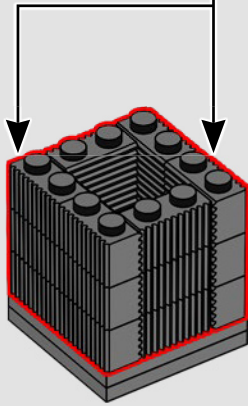

3

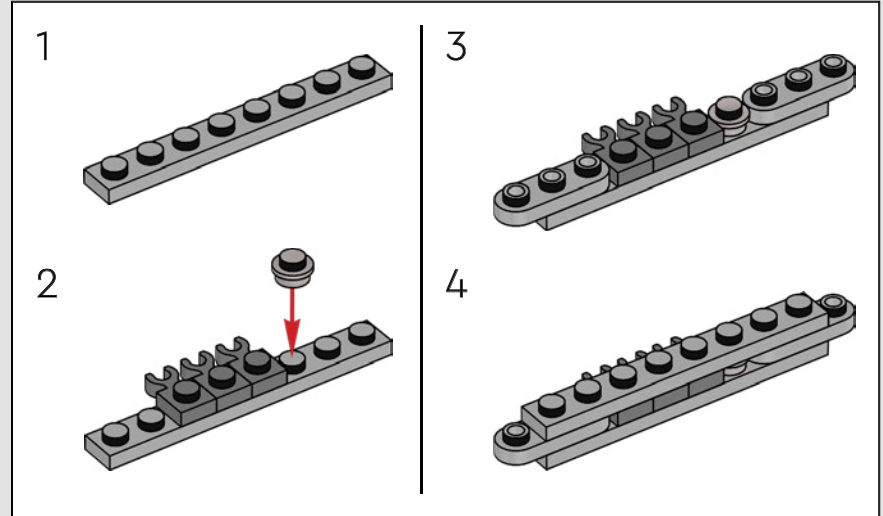
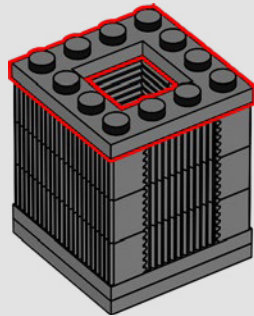

4

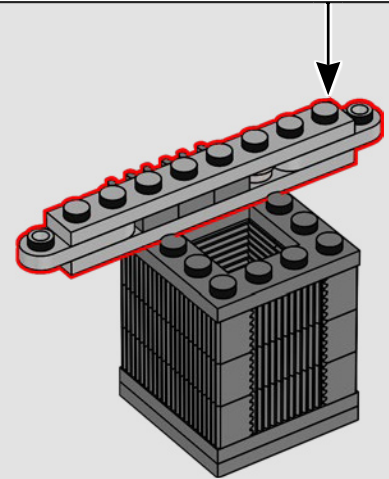

5

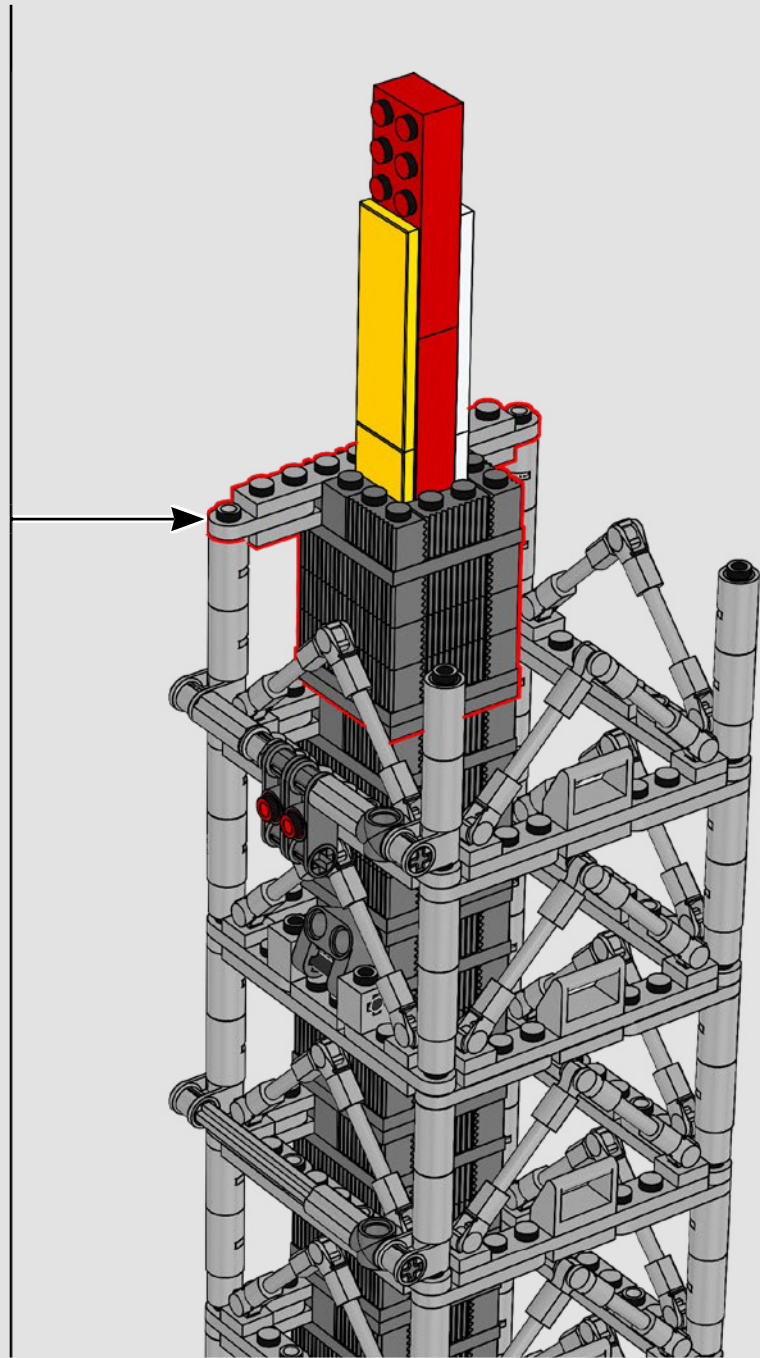
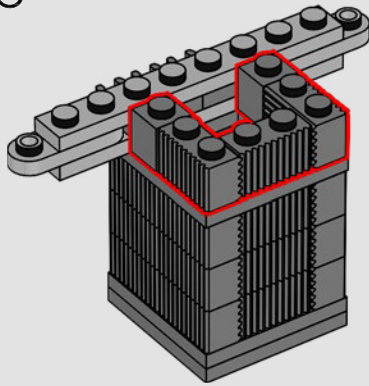



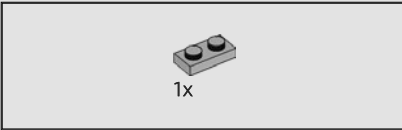
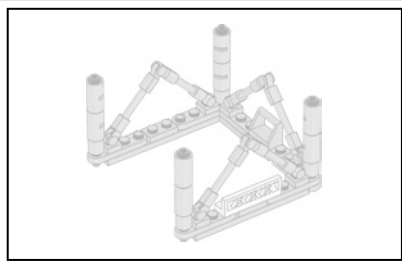

1x

284

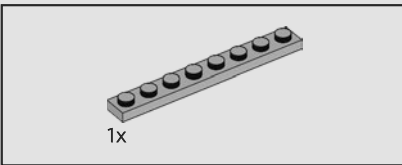
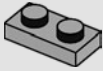

1x

285

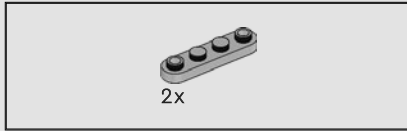
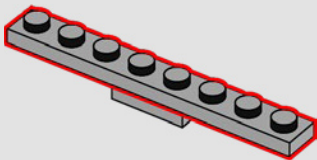

2x

286

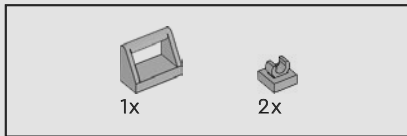
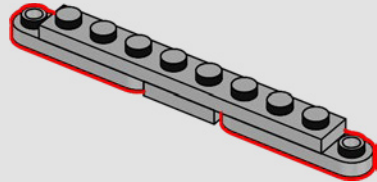

1x

2x

287

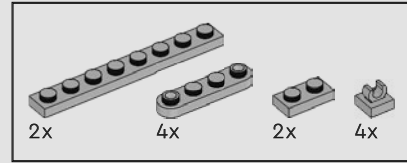
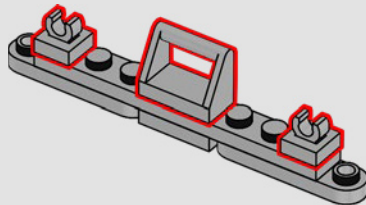

2x

4x

2x

4x

288

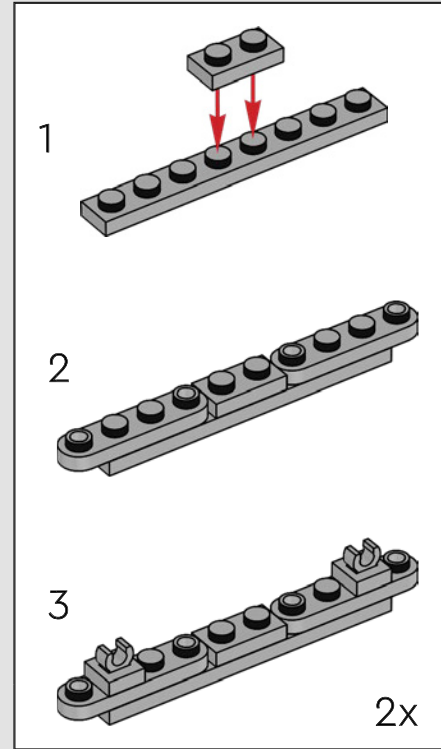

1

2

3

2x

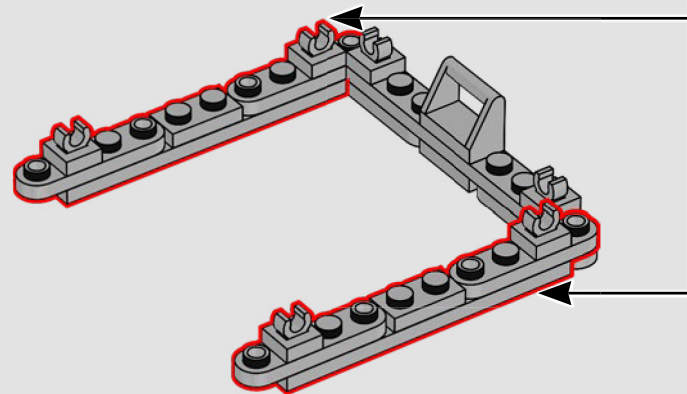

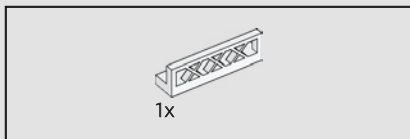

289

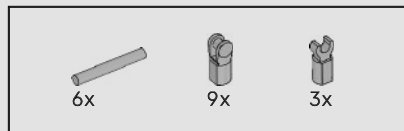
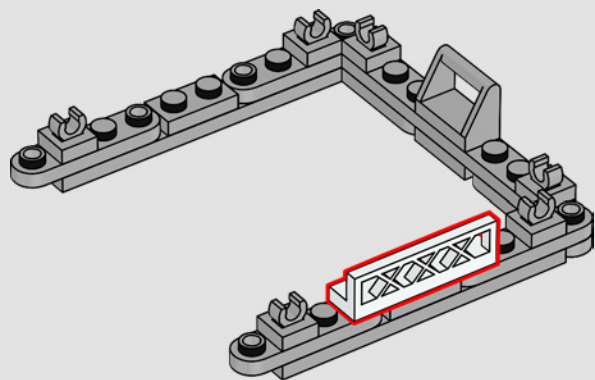

290

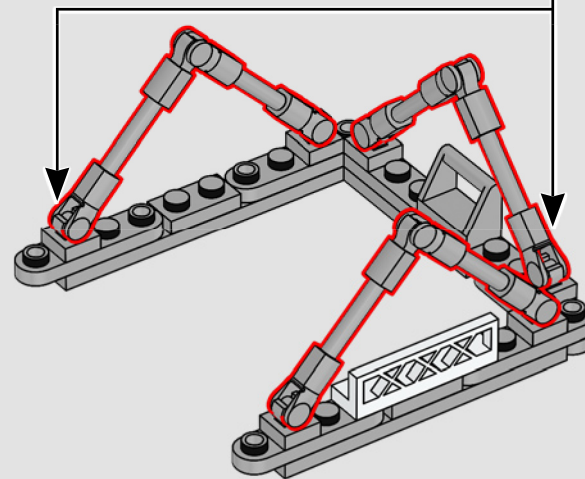
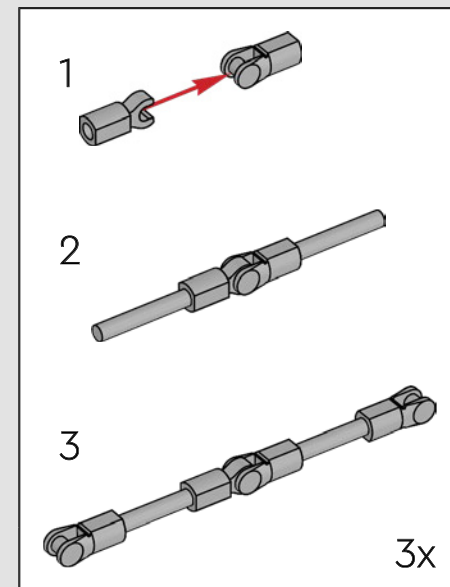

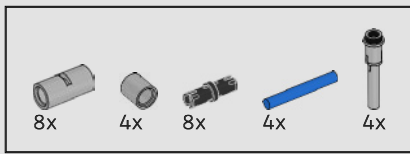

291

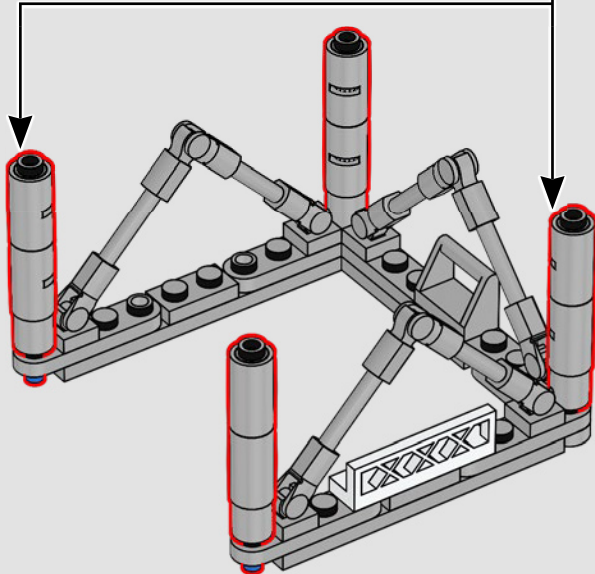
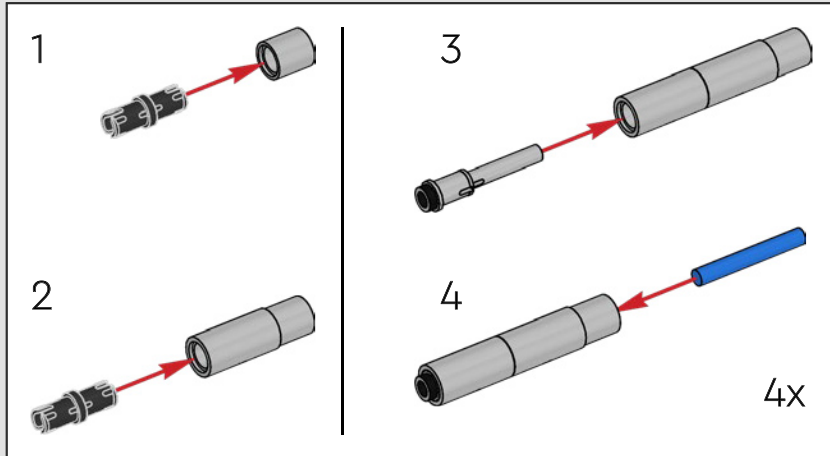

292

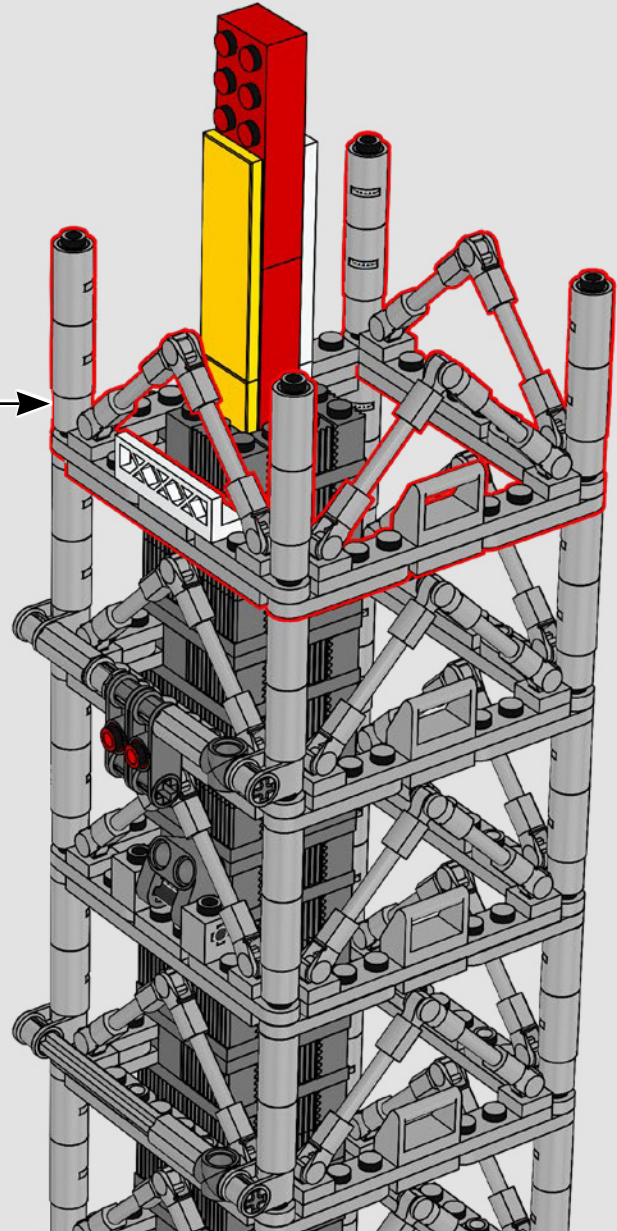

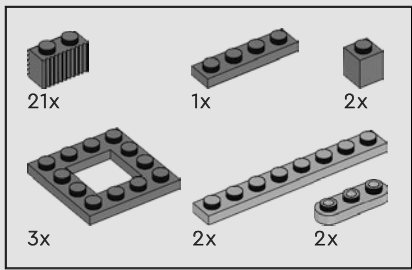

293

1

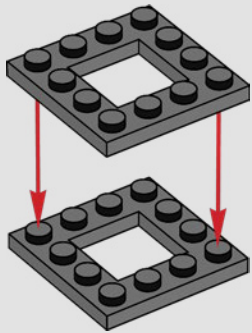

2

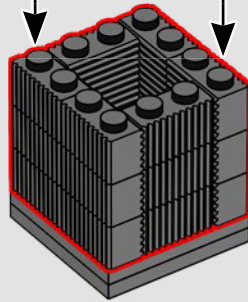

6x

3

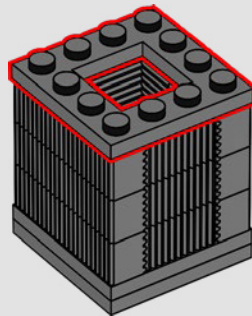

1

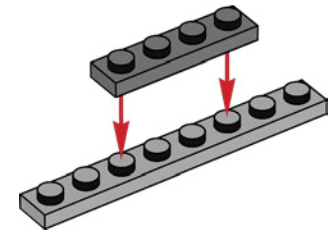

2

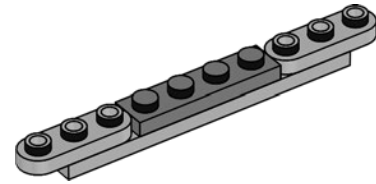

3

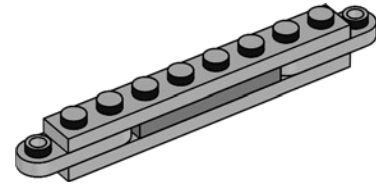

4

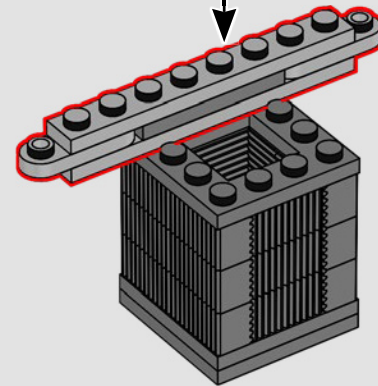

5

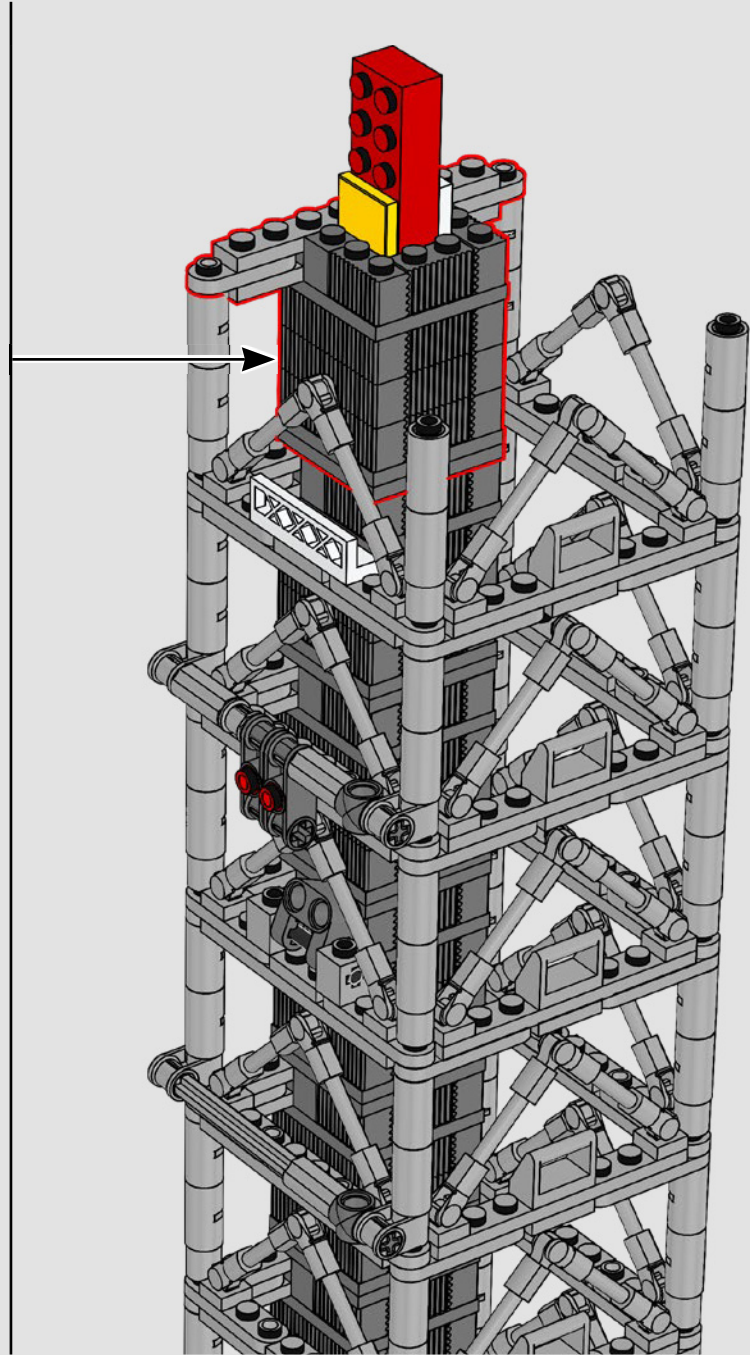
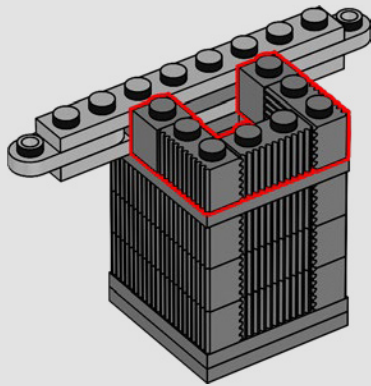

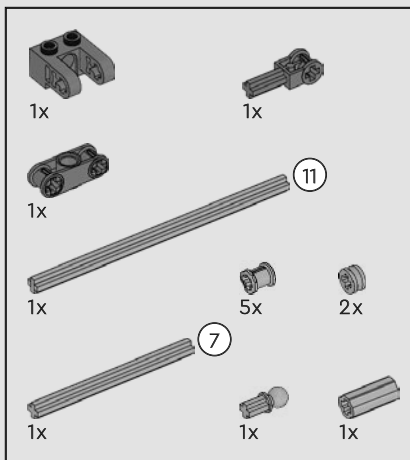

294

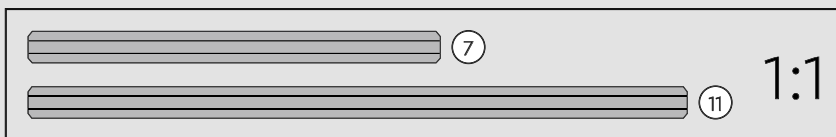
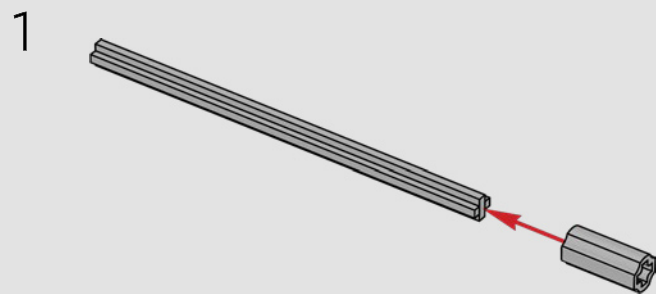

2

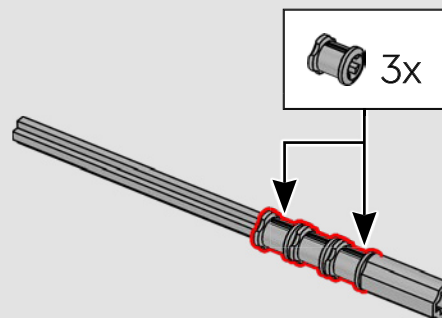

3

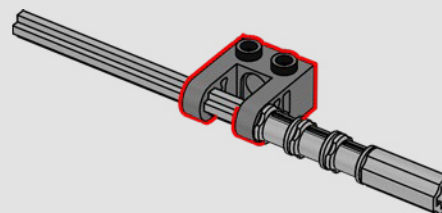

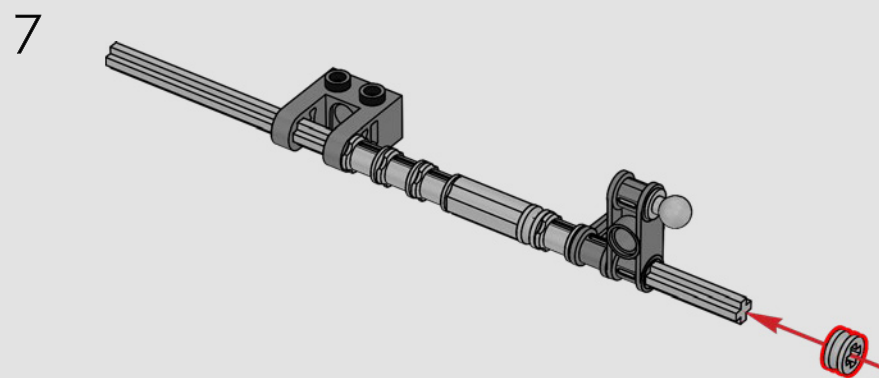
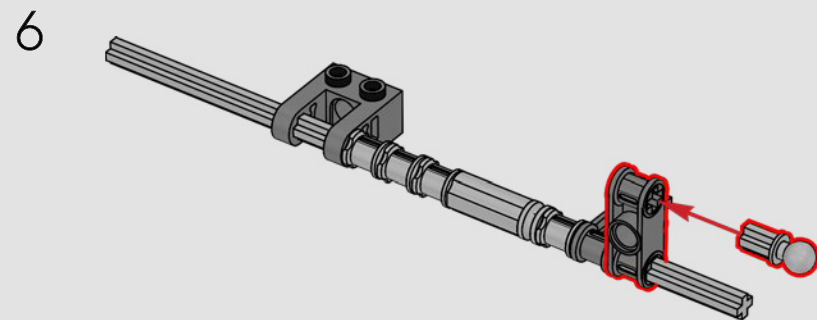
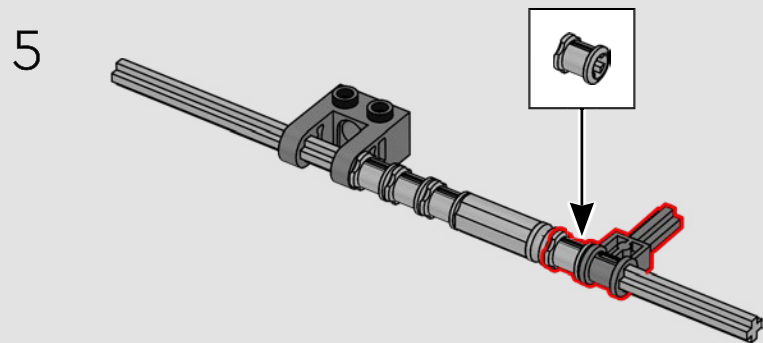
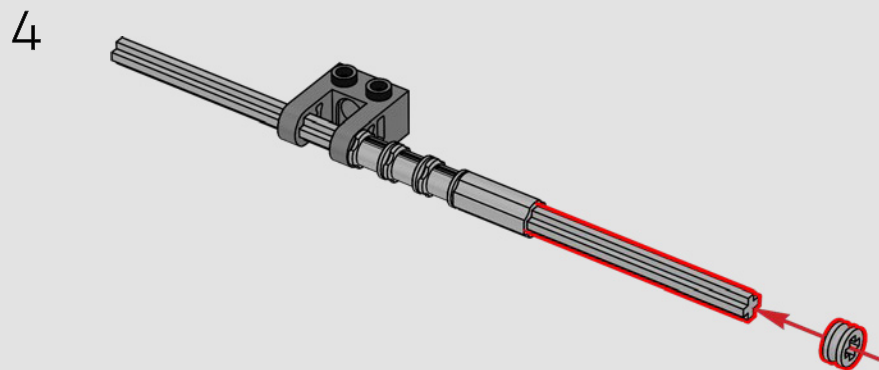

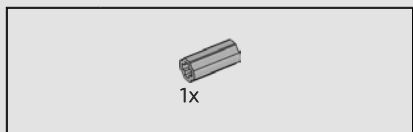
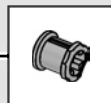
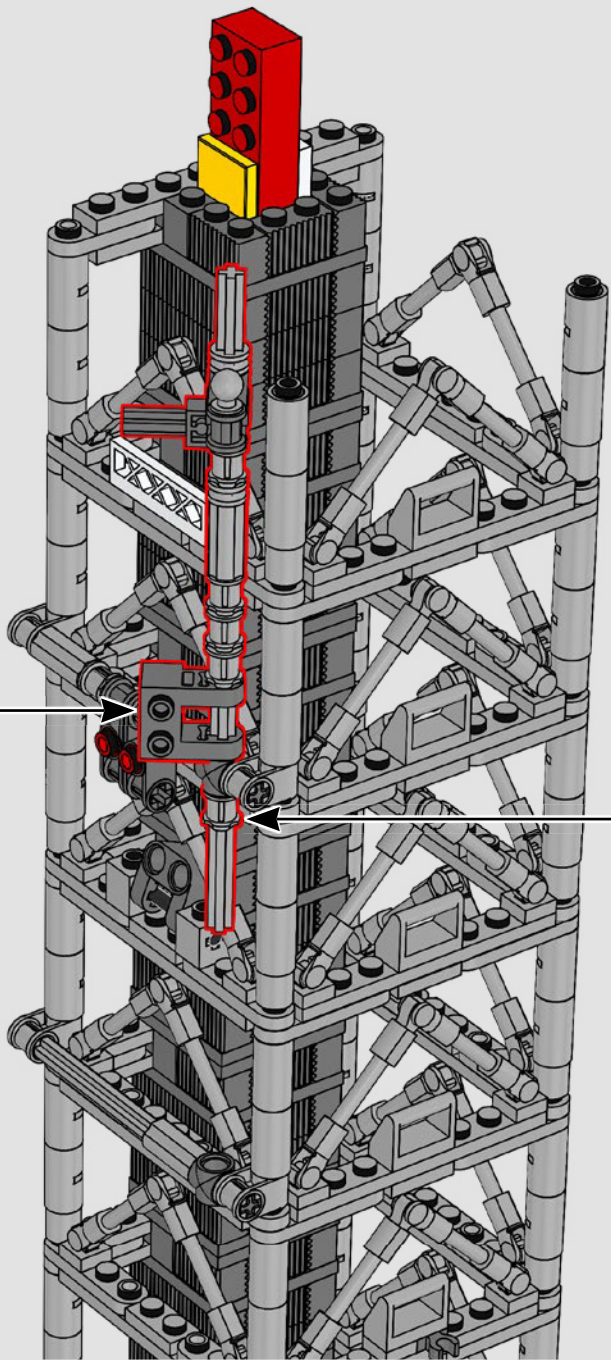

295

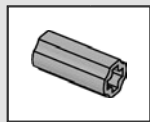
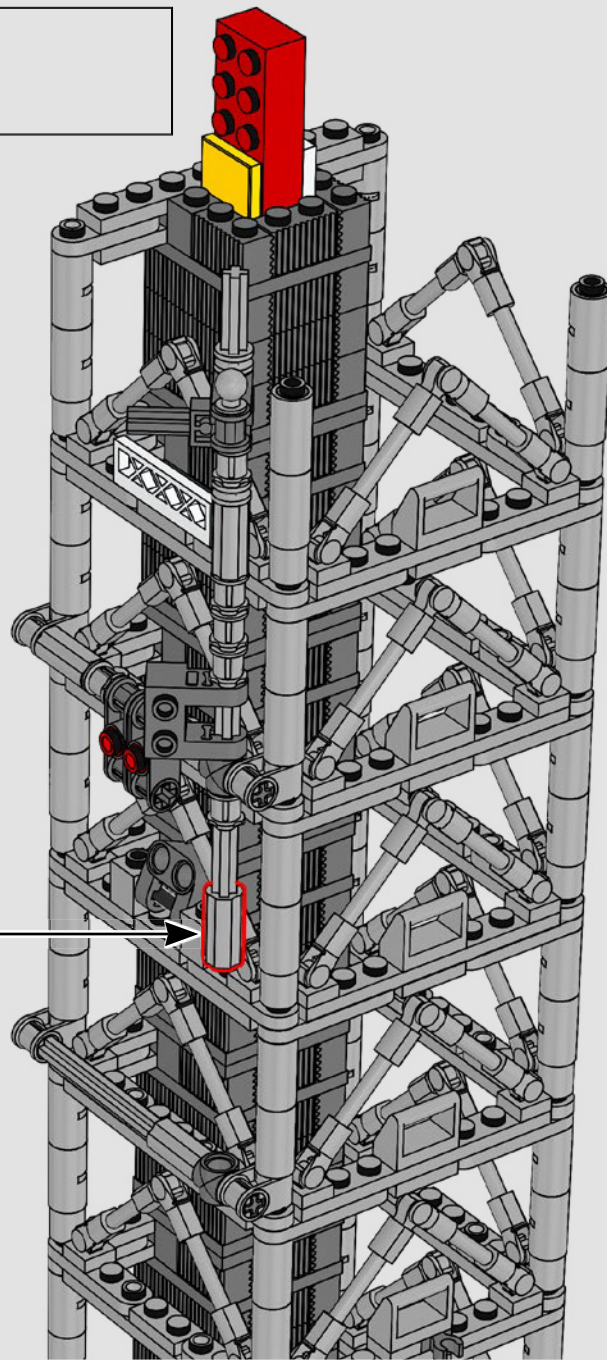



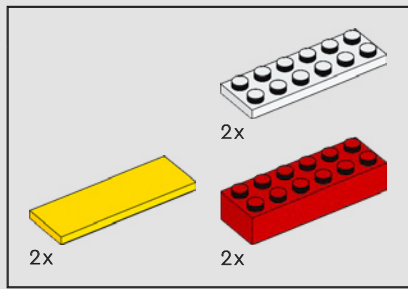

296

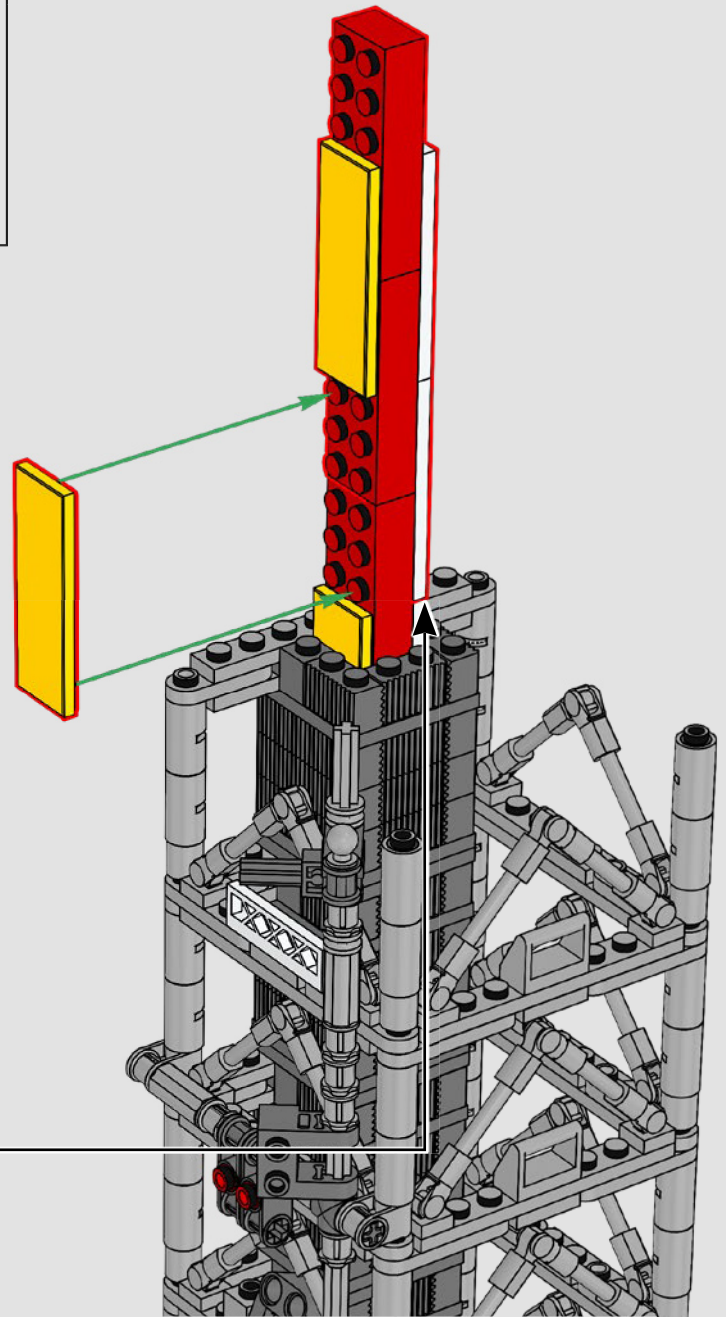
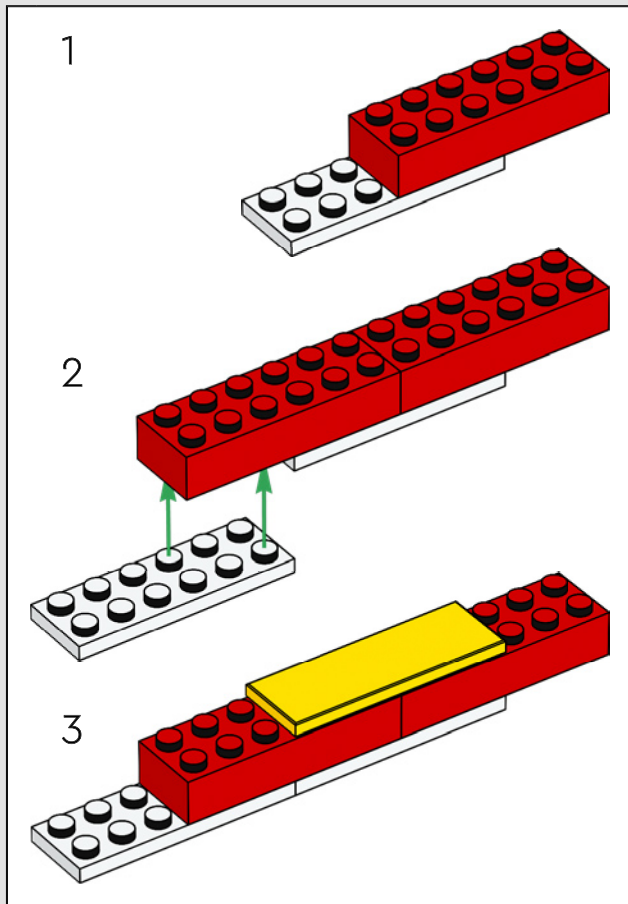

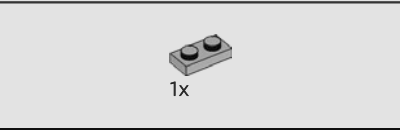
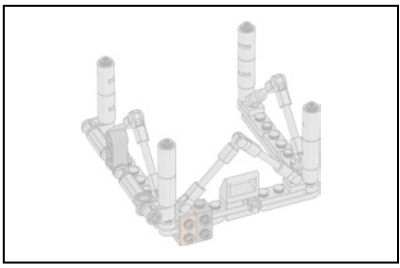

297

1x

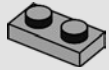

298

1x

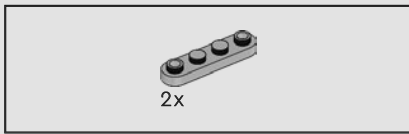
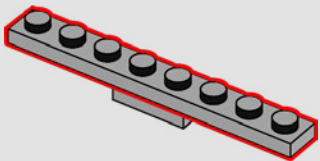

2x

299

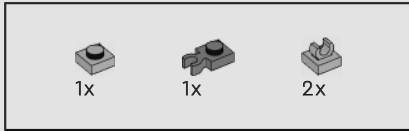
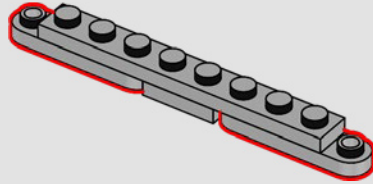

300

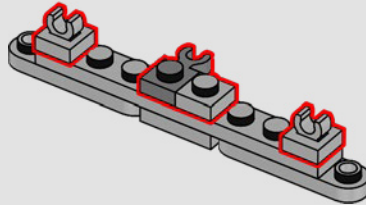

1x

301

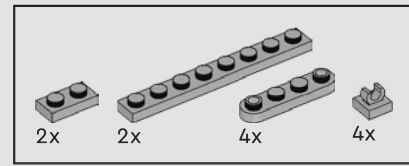
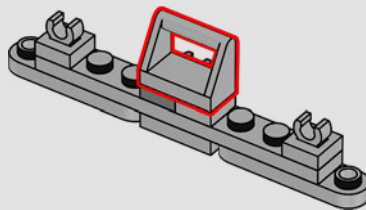

302

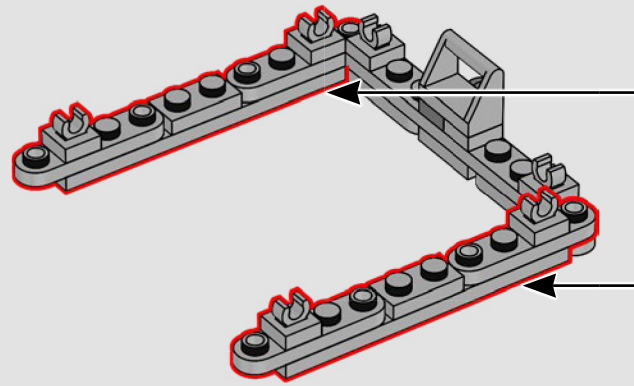
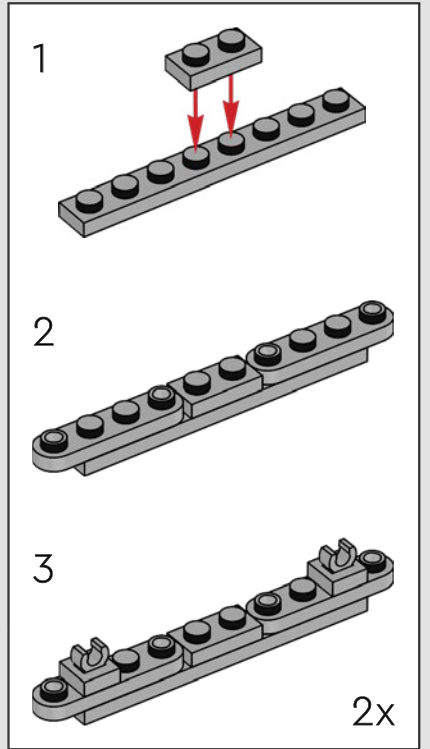

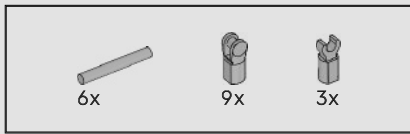

303

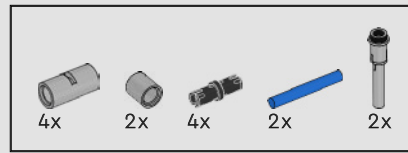
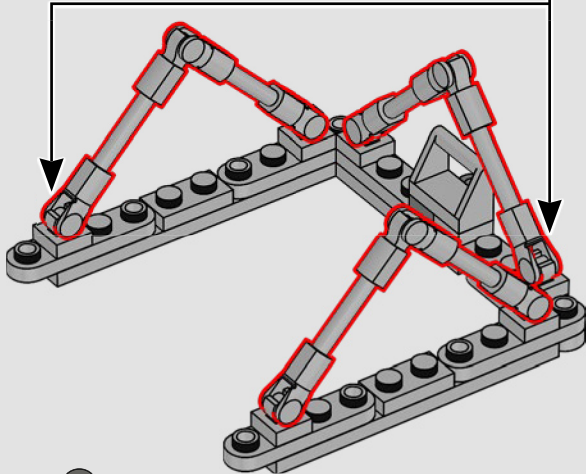
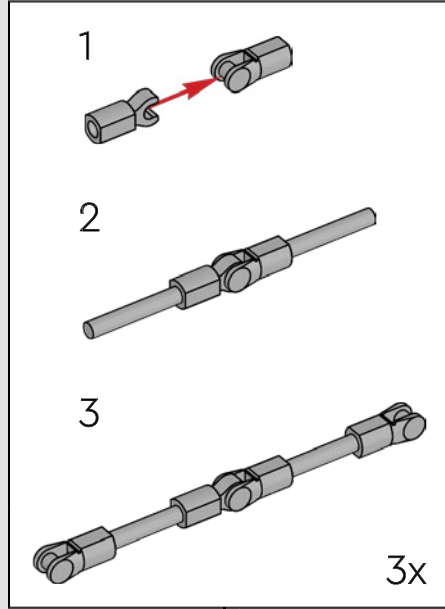

304

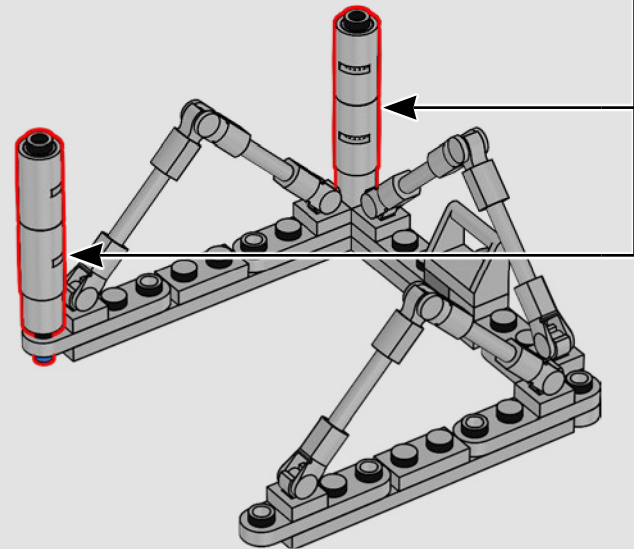
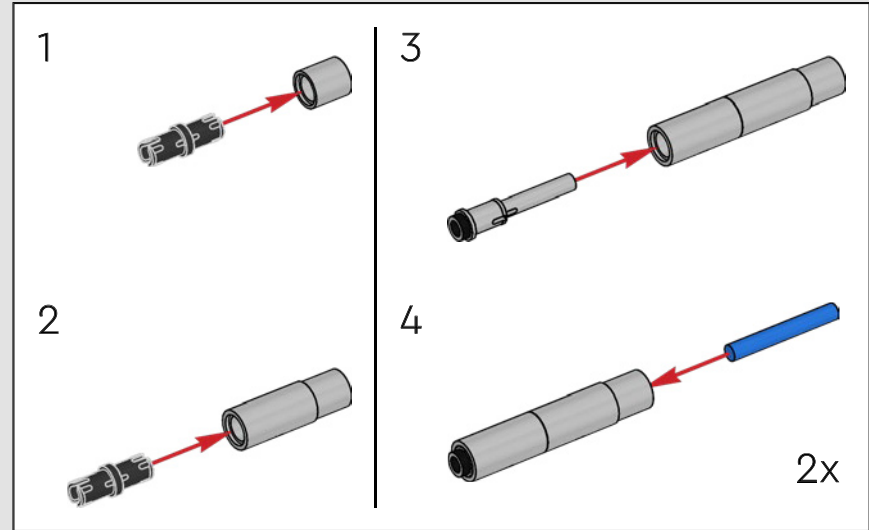

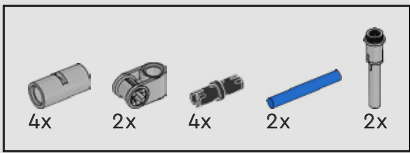

305

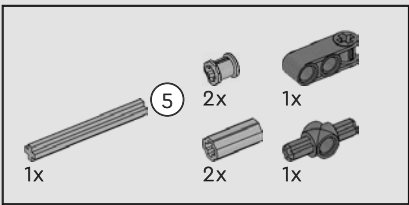
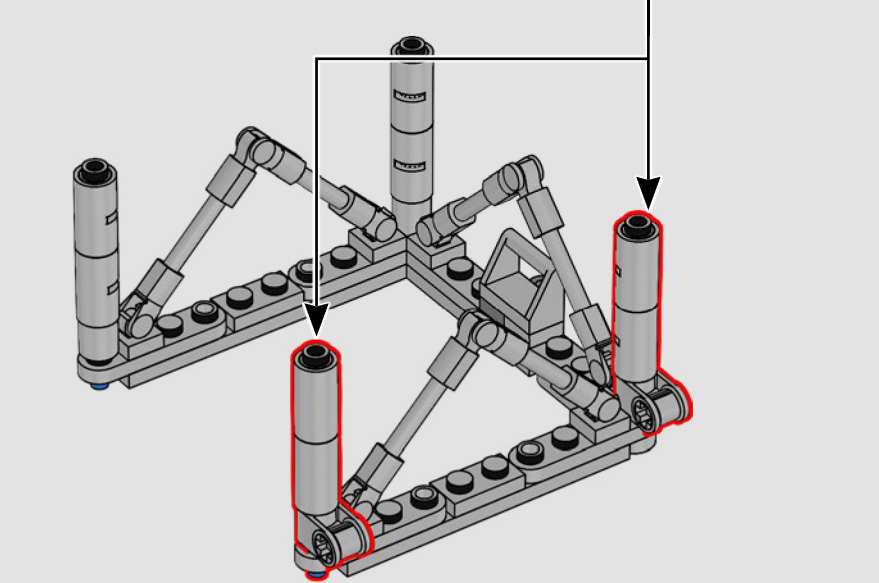
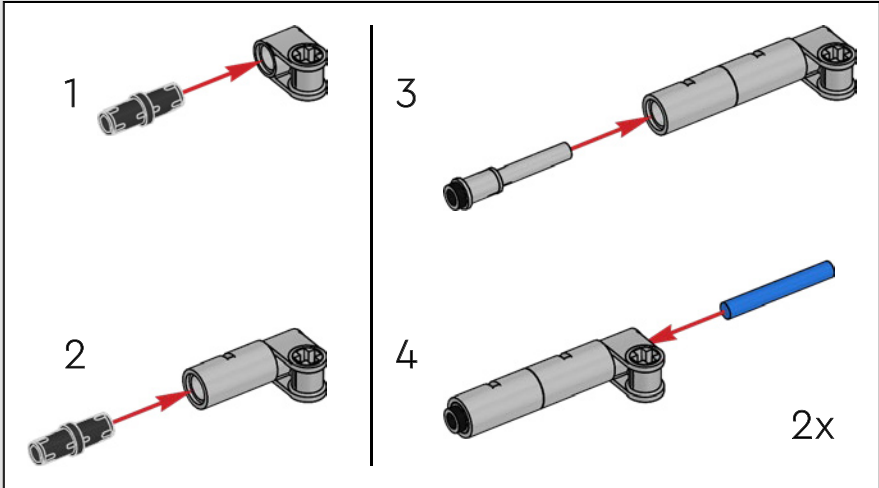

306

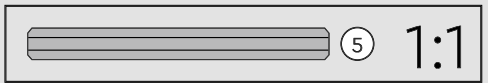
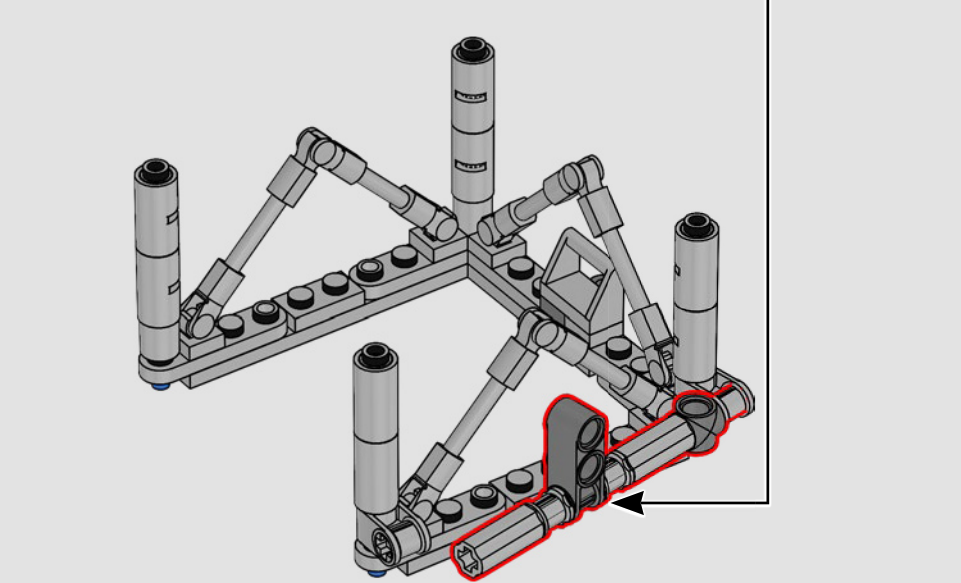
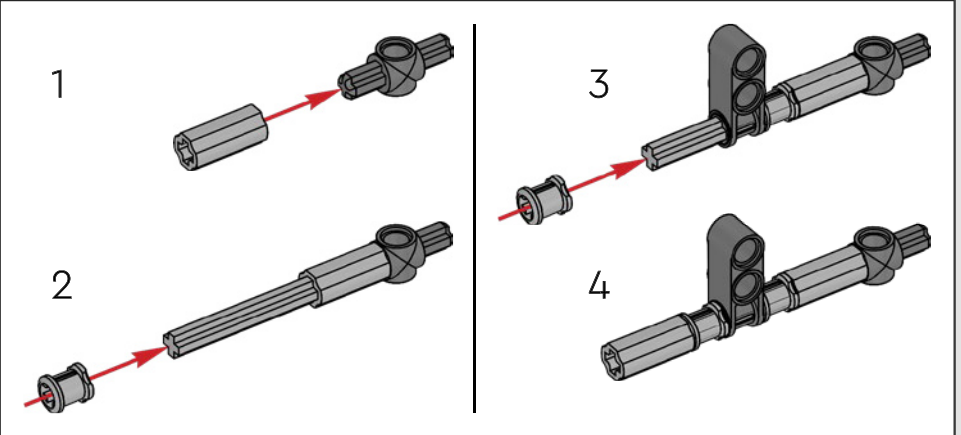

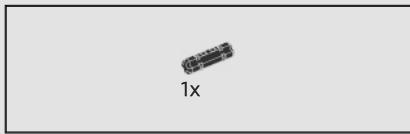

307

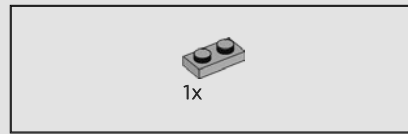
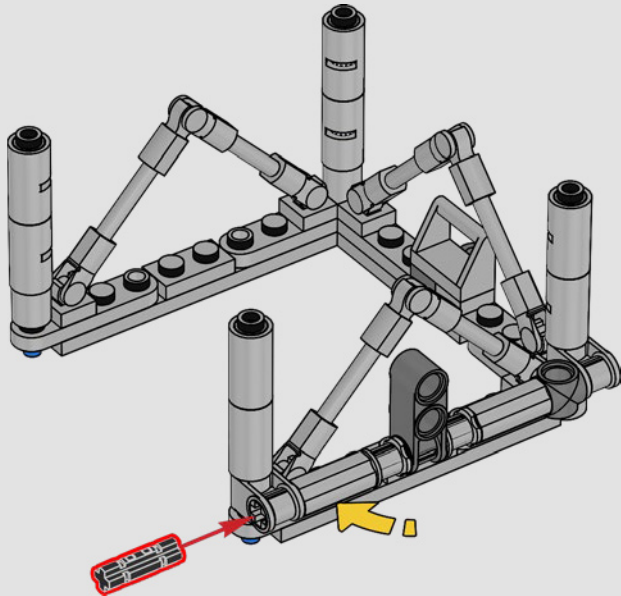

308

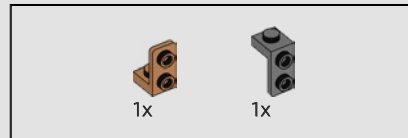
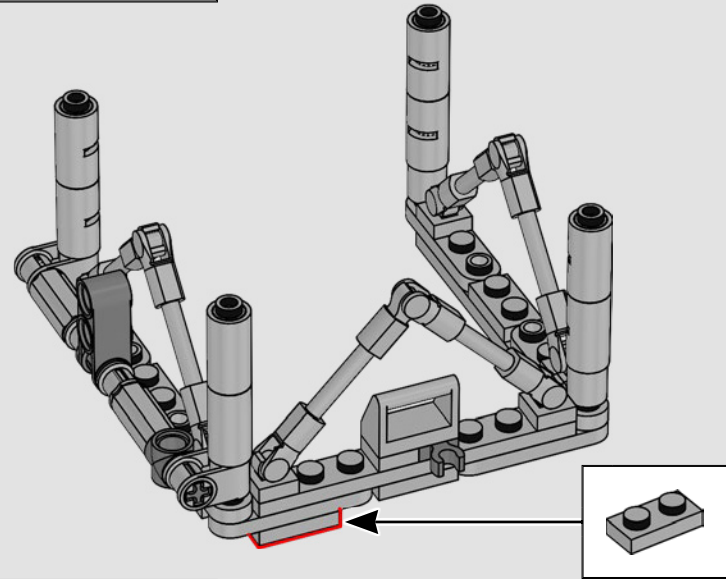
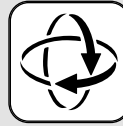

309

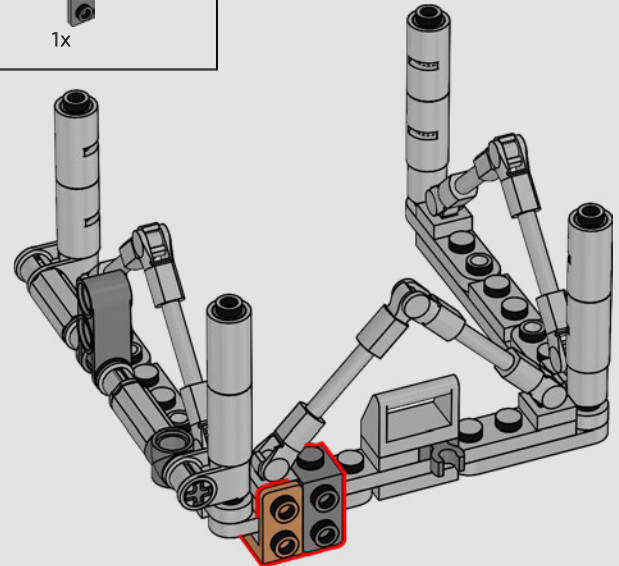

310

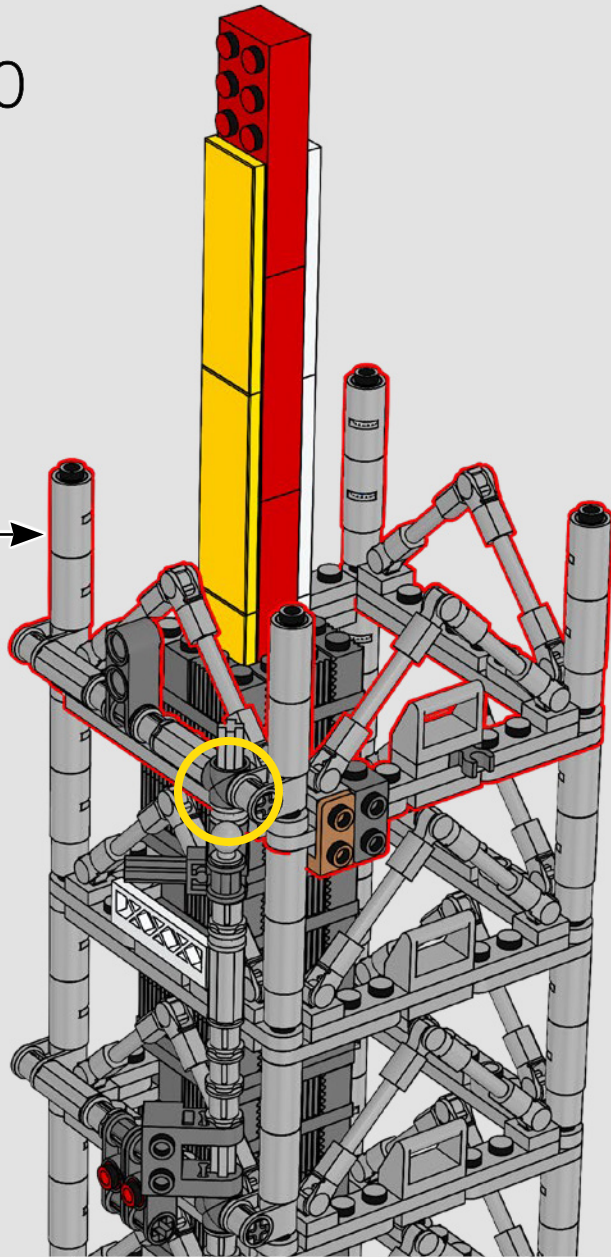

311

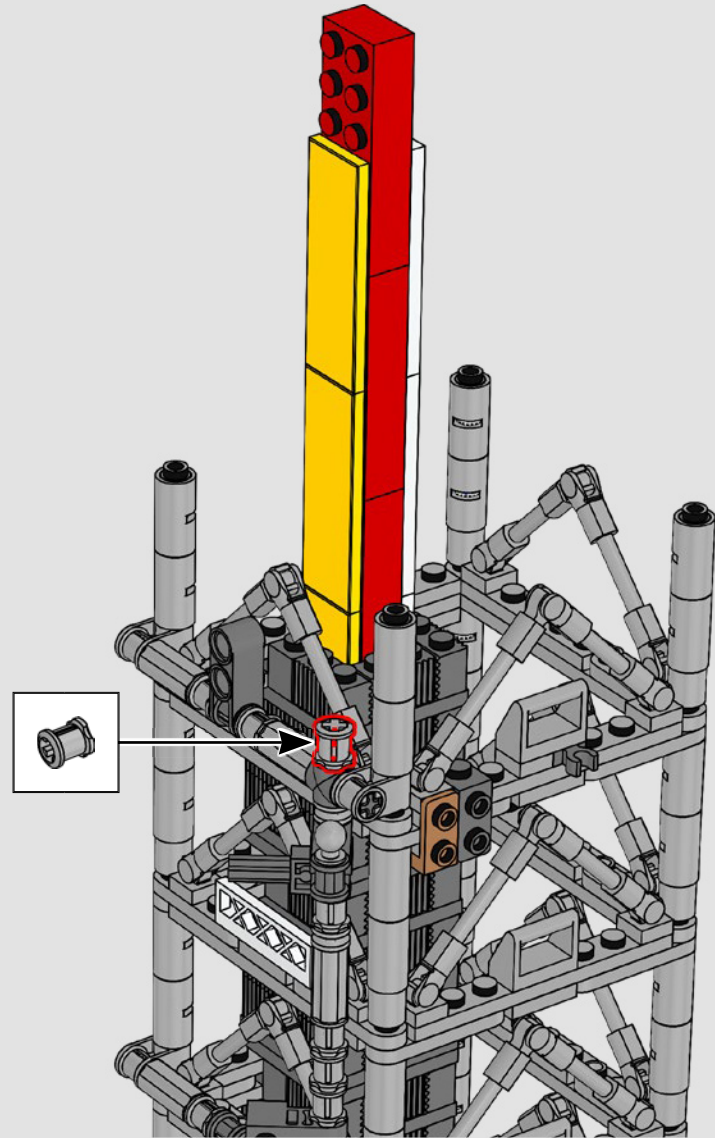
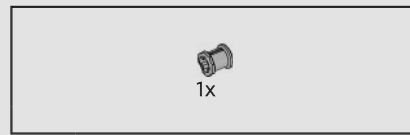

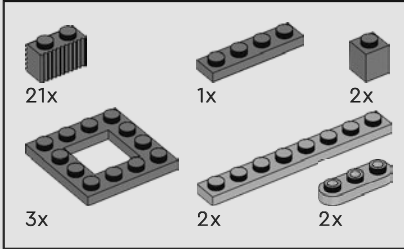
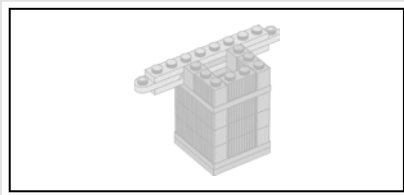

312

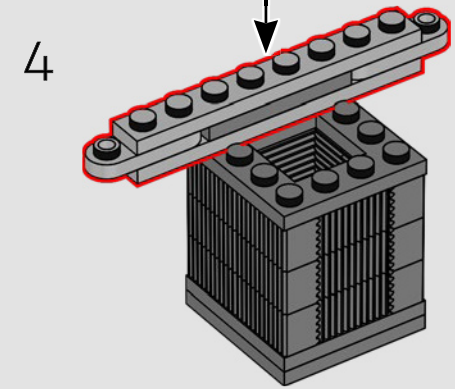
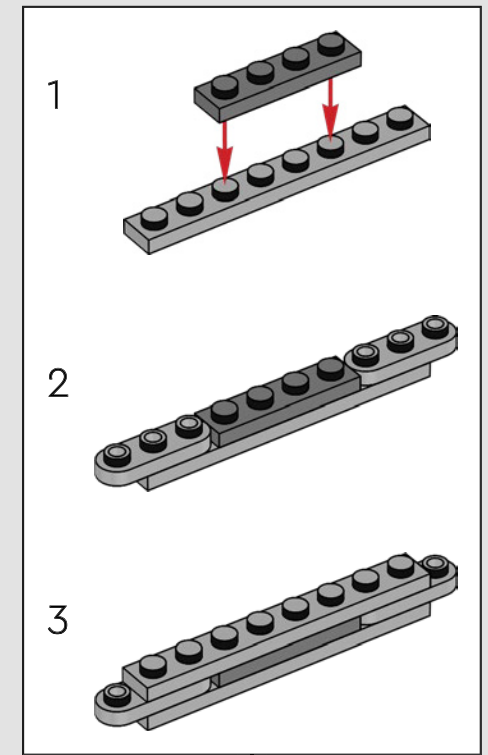
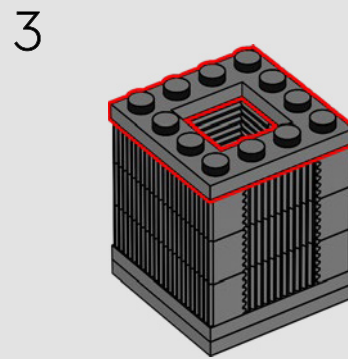
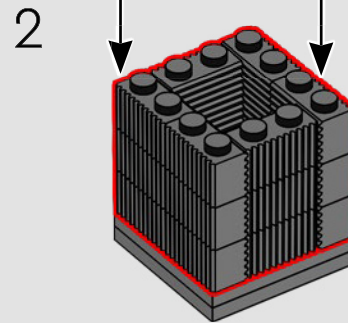
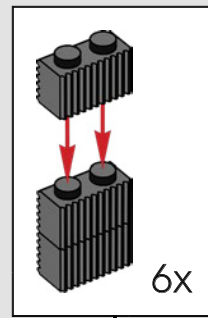
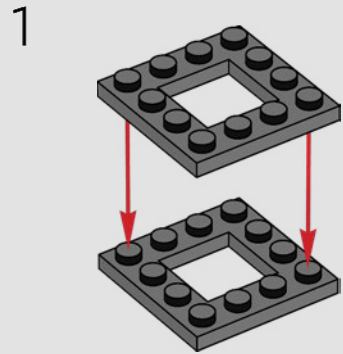

5

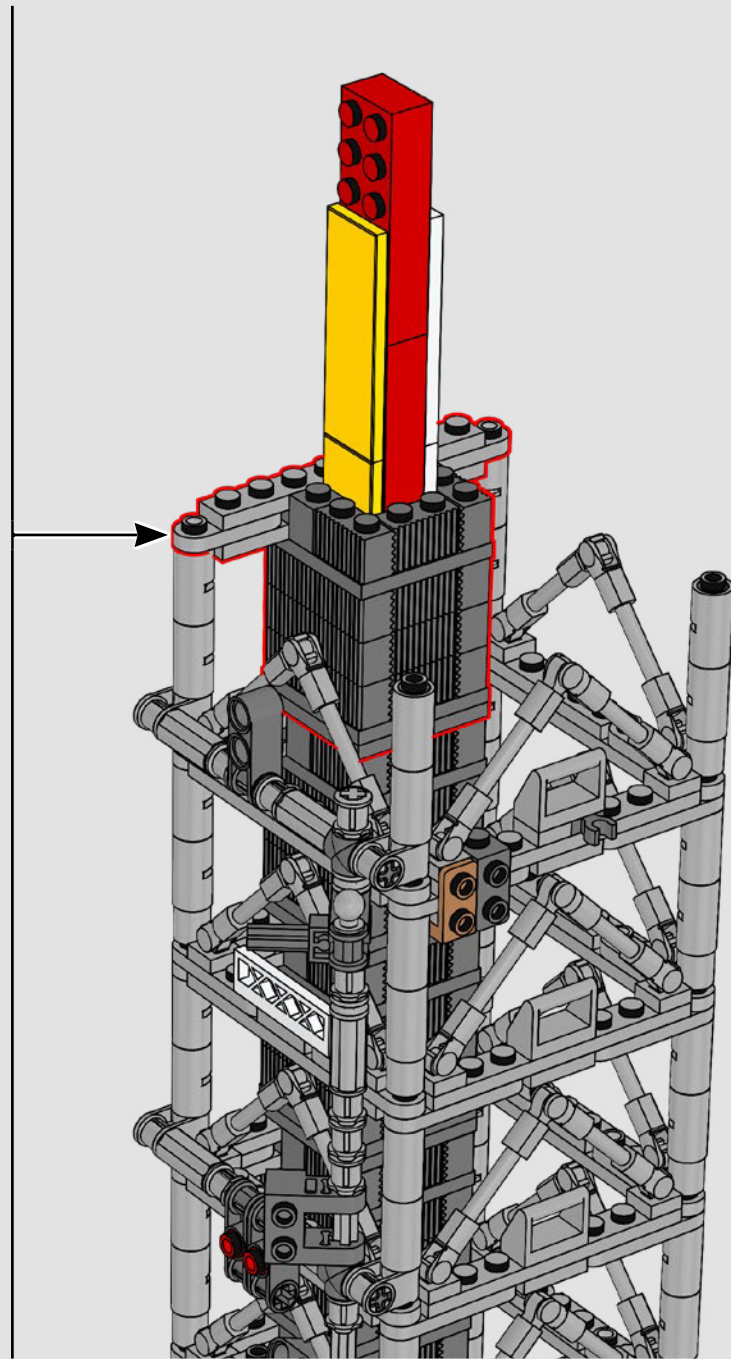
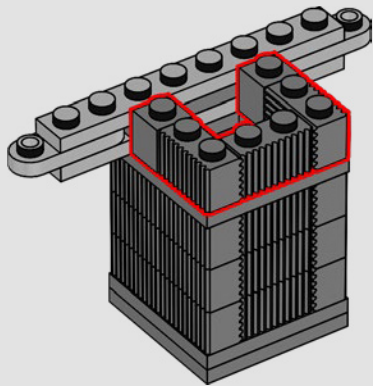



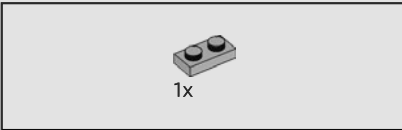
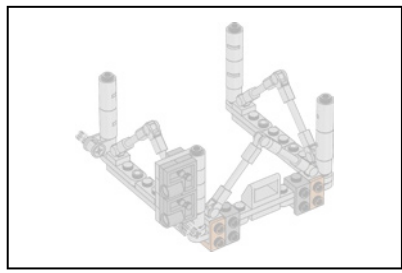

313

1x

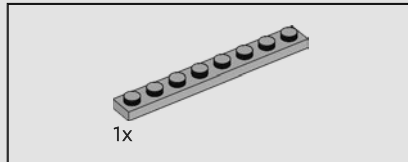
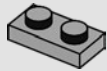

314

1x

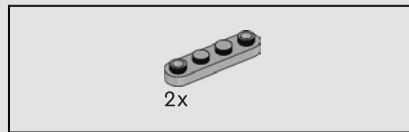
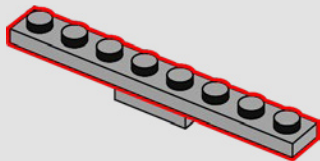

315

2x

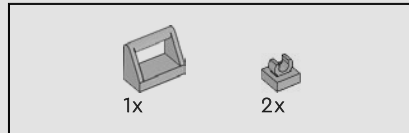
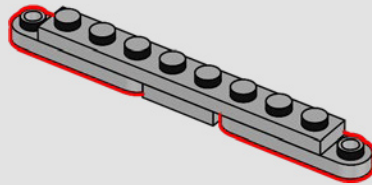

316

1x

2x

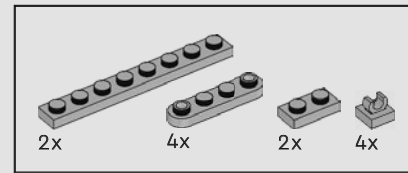
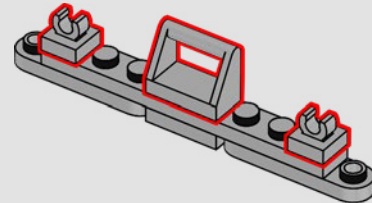

317

2x

4x

2x

4x

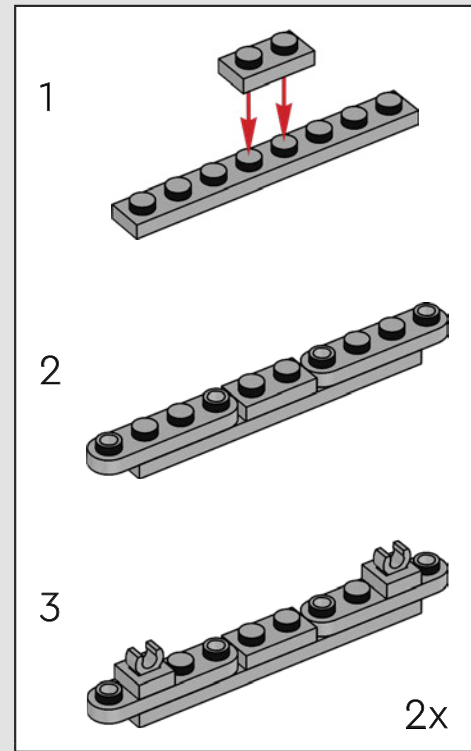

1

2

3

2x

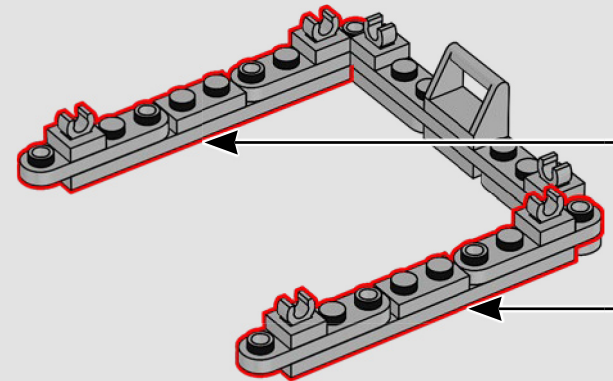

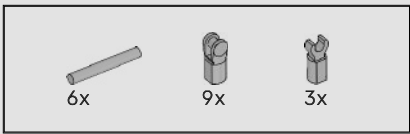

318

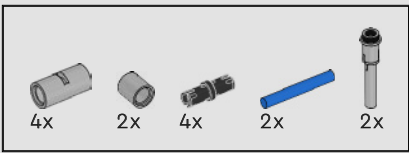
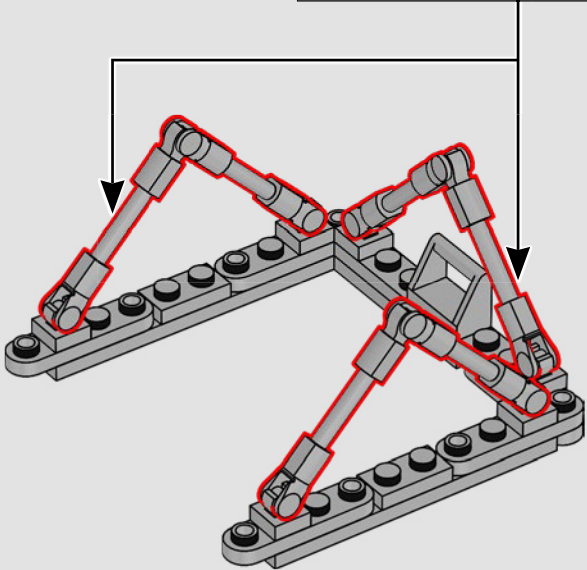
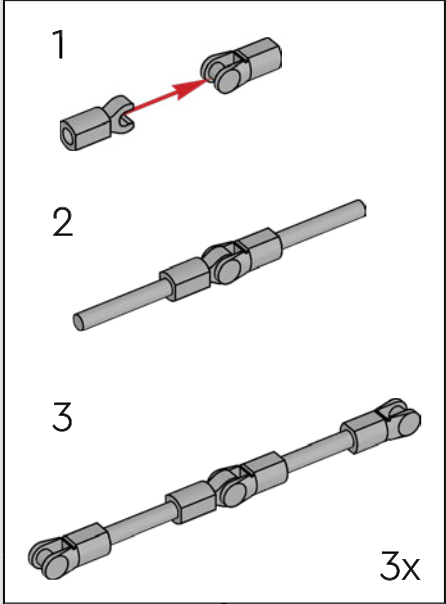

319

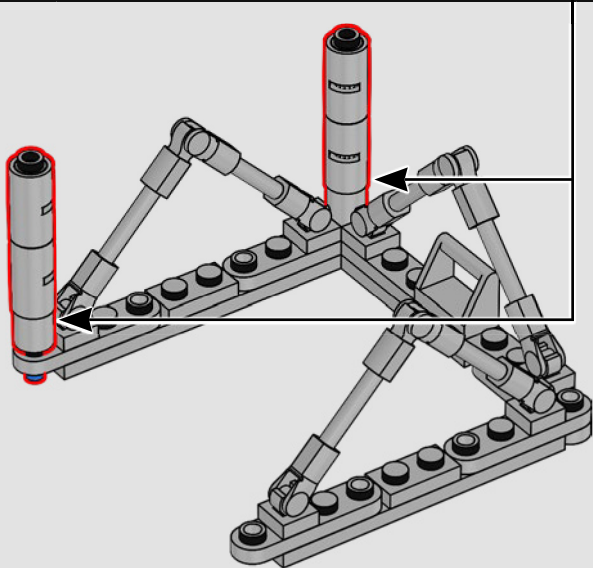
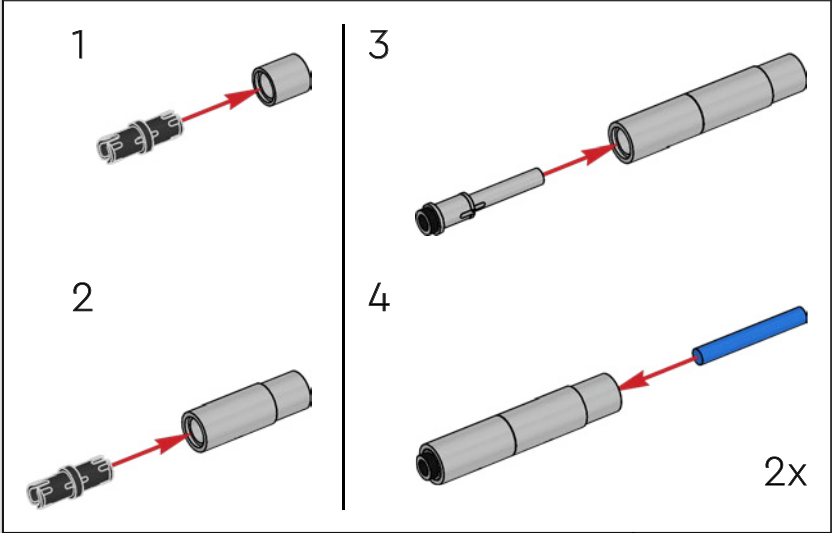

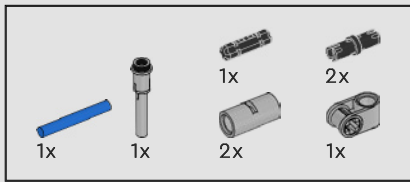

320

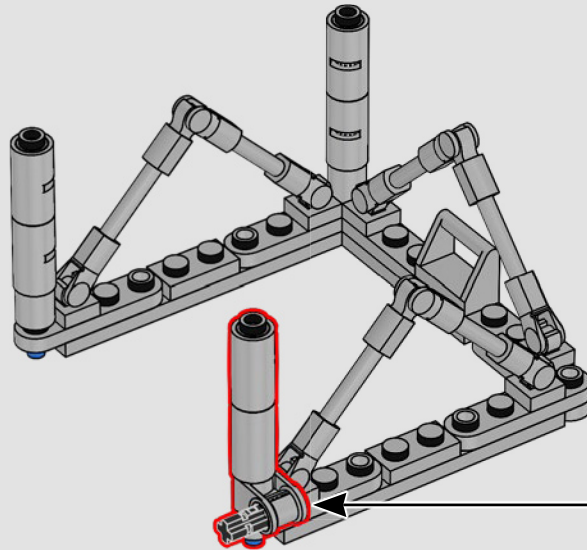
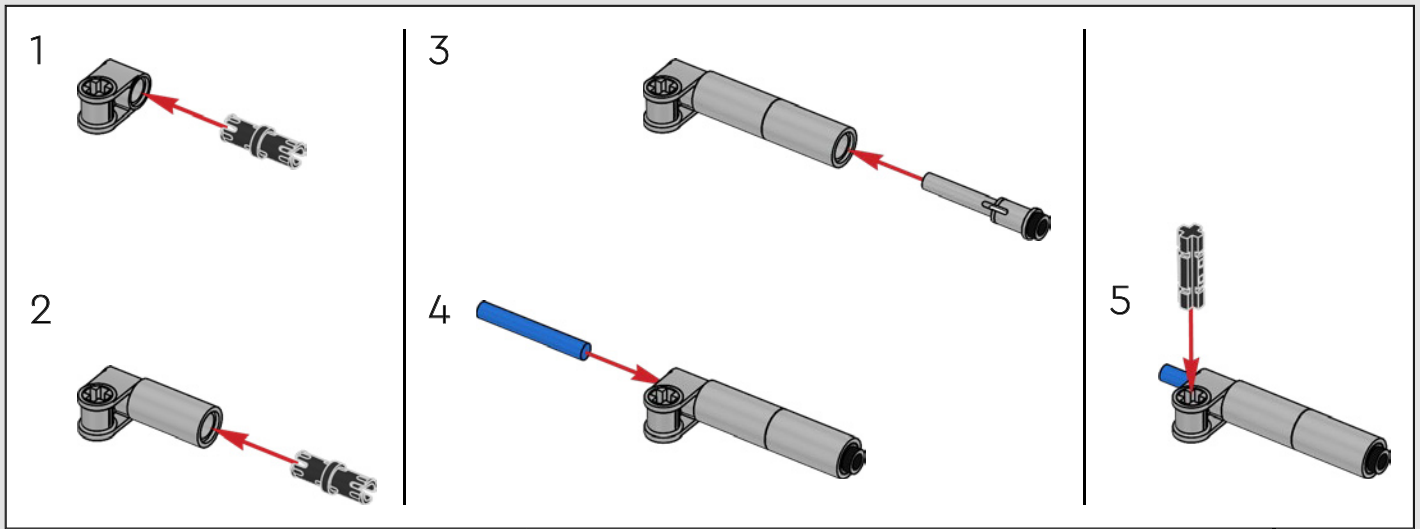

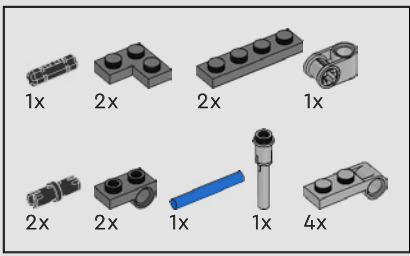

321

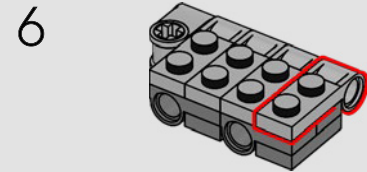
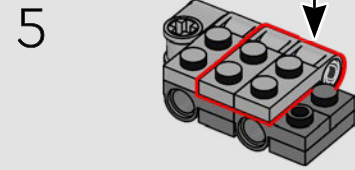
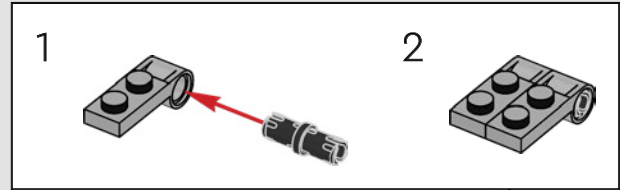
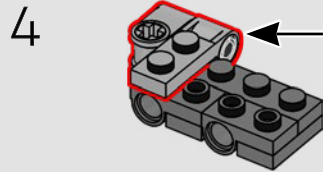
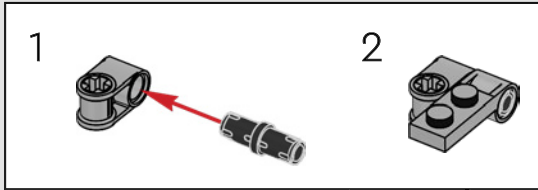
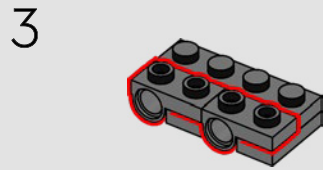
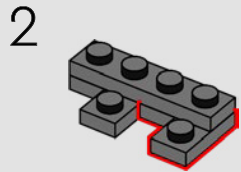
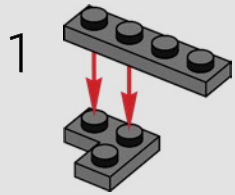

7

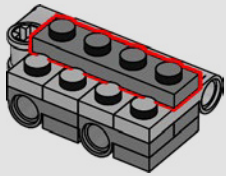

8

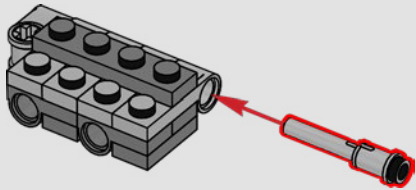

9

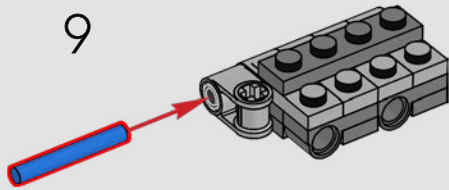

10

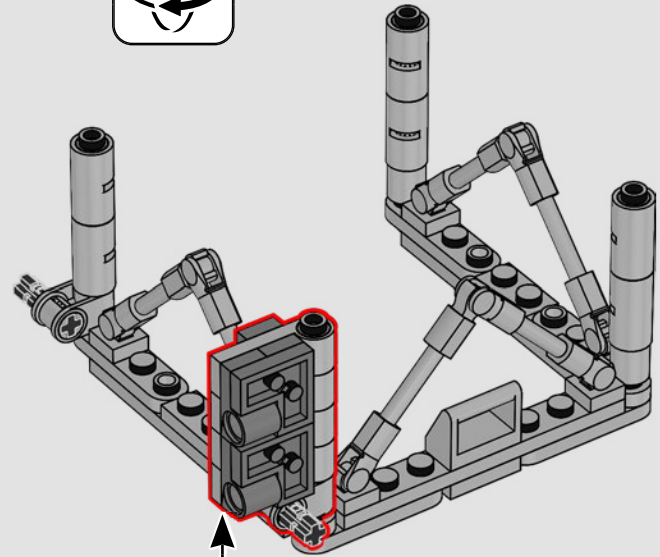
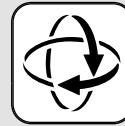
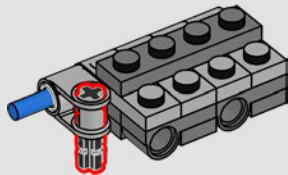



2x

322

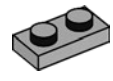
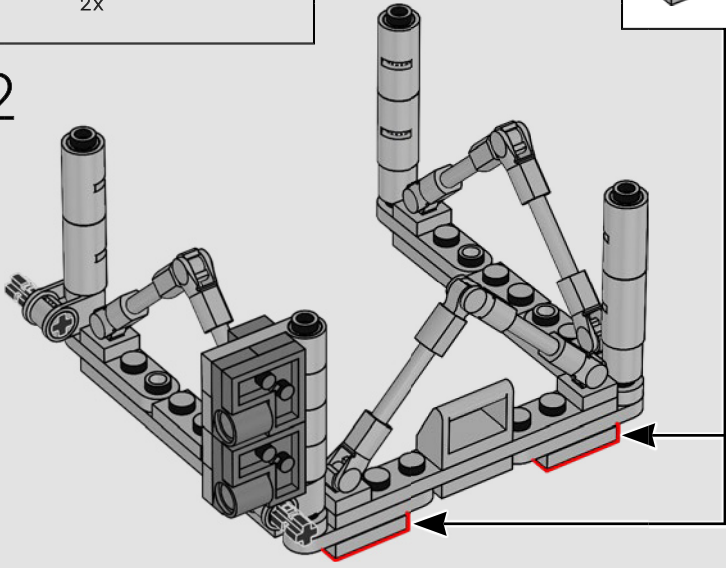

2x

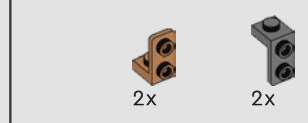

2x

2x

323

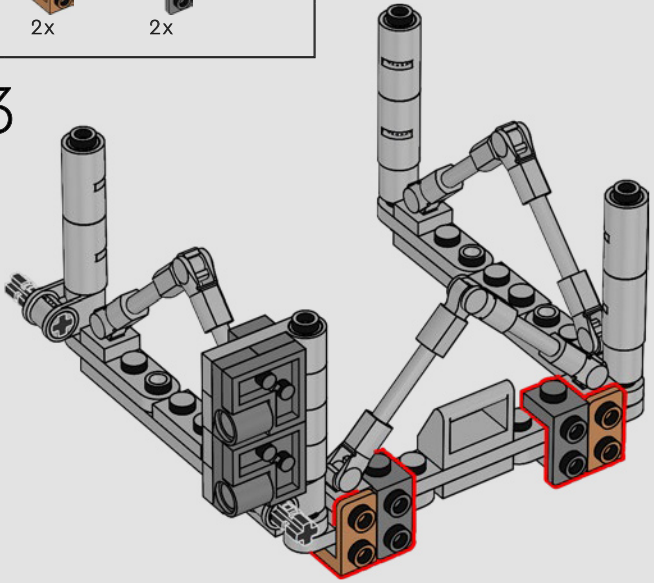

324

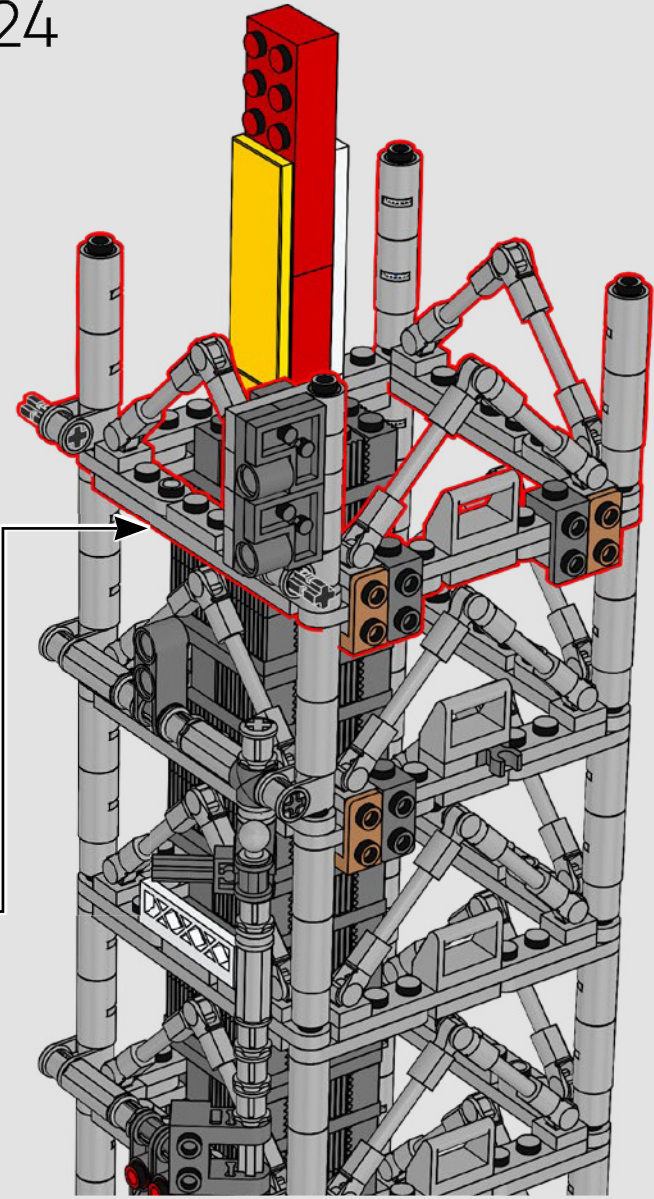

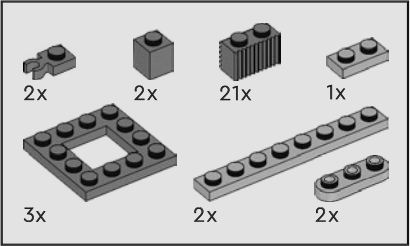
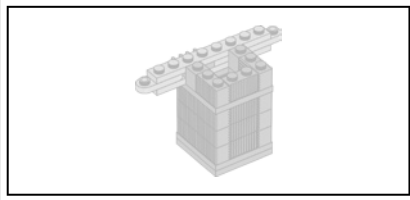

325

1

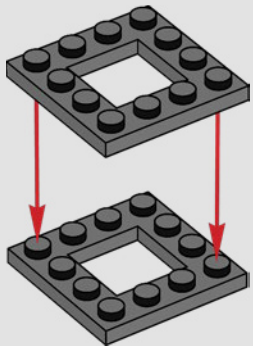

2

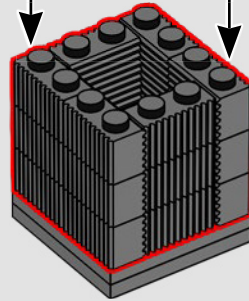

3

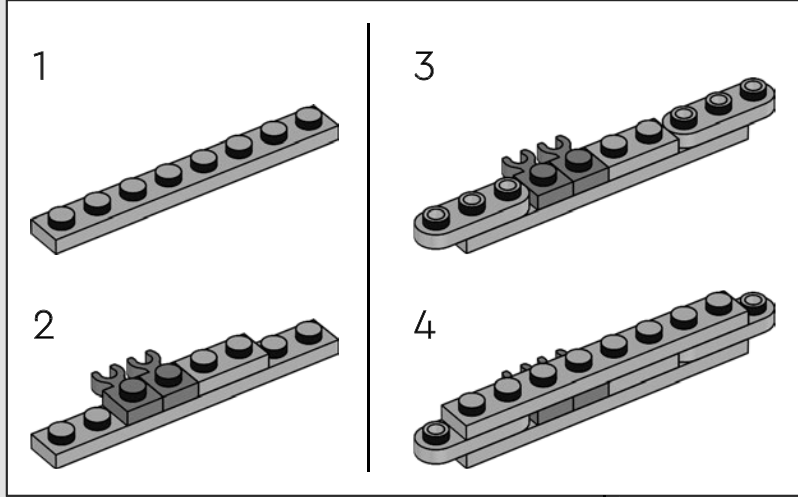
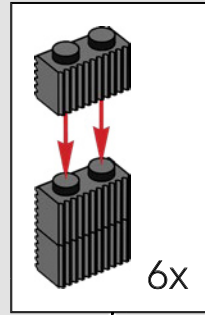
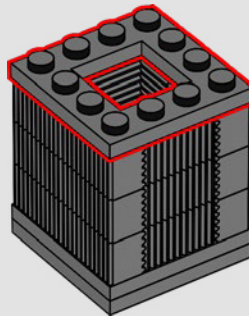

4

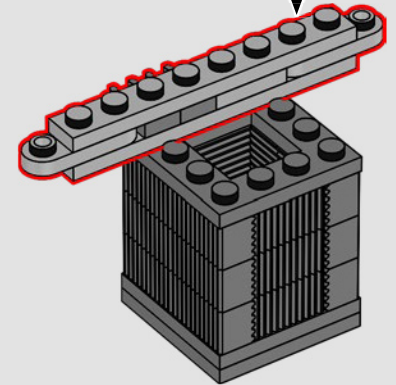

5

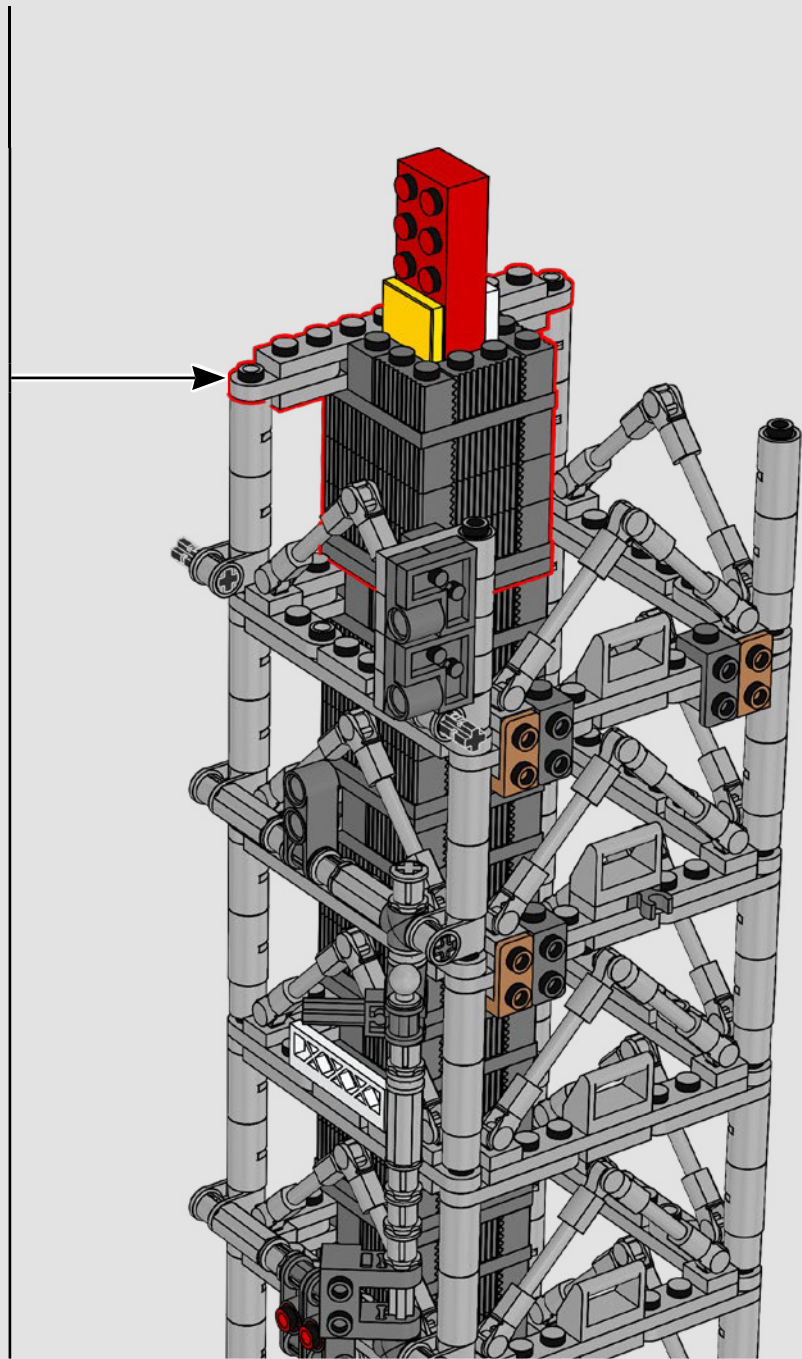
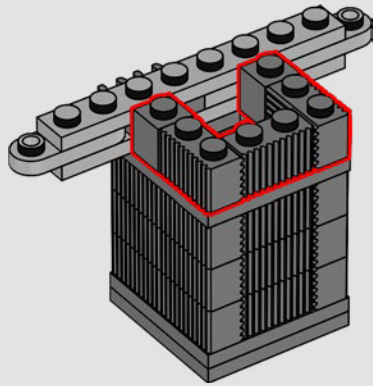



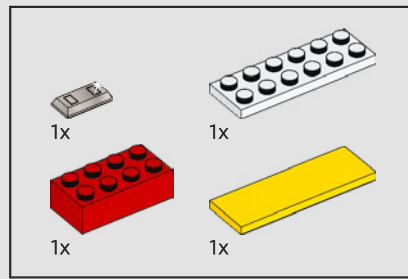

326

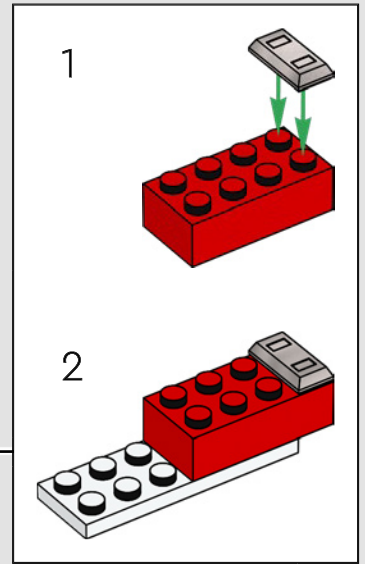
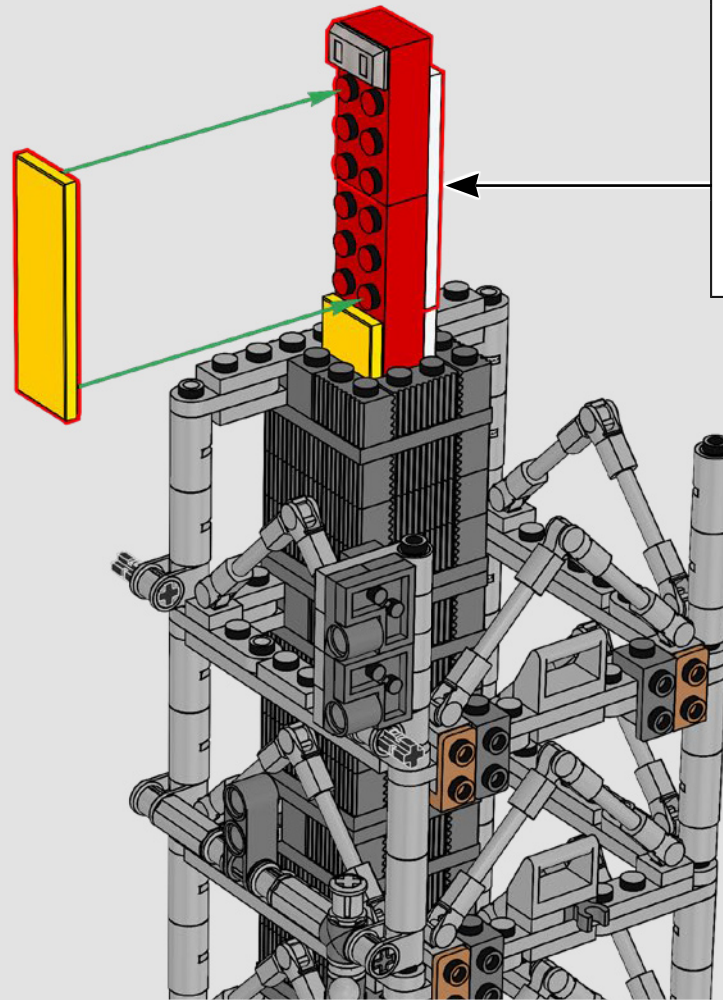

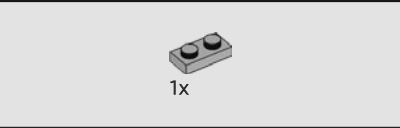
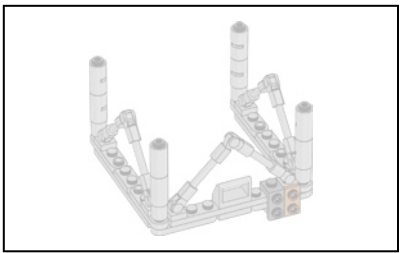

327

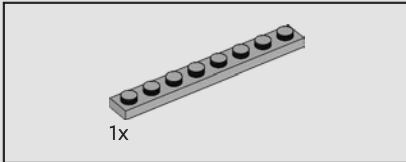
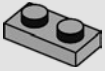

328

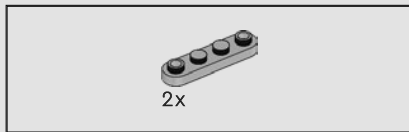
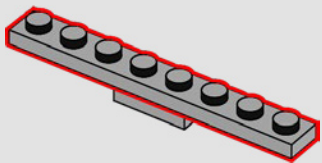

329

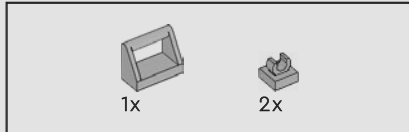
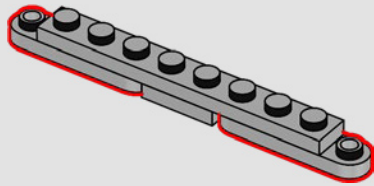

330

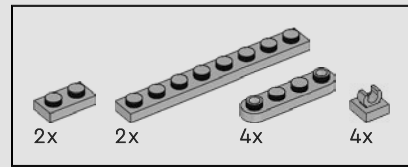
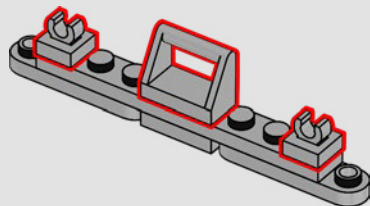

331

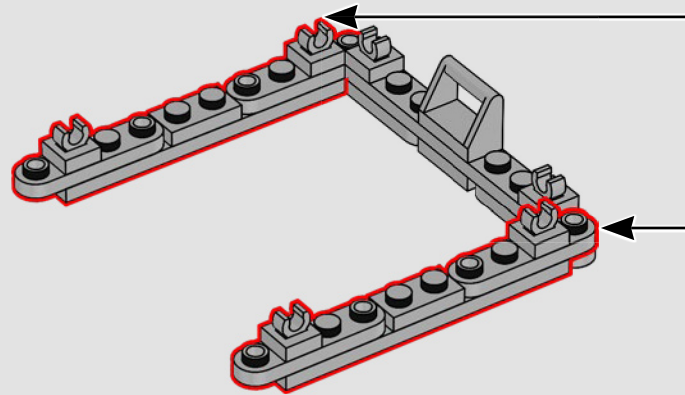
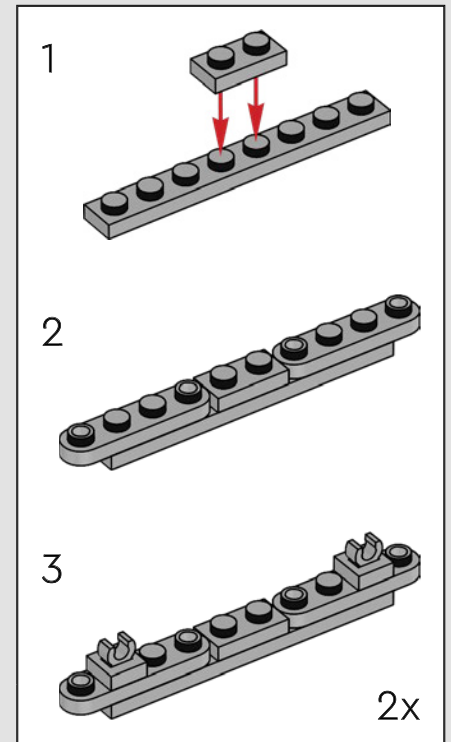

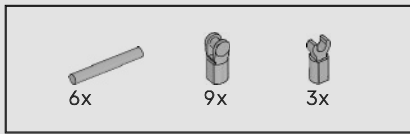

332

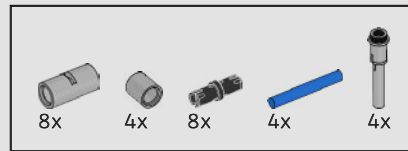
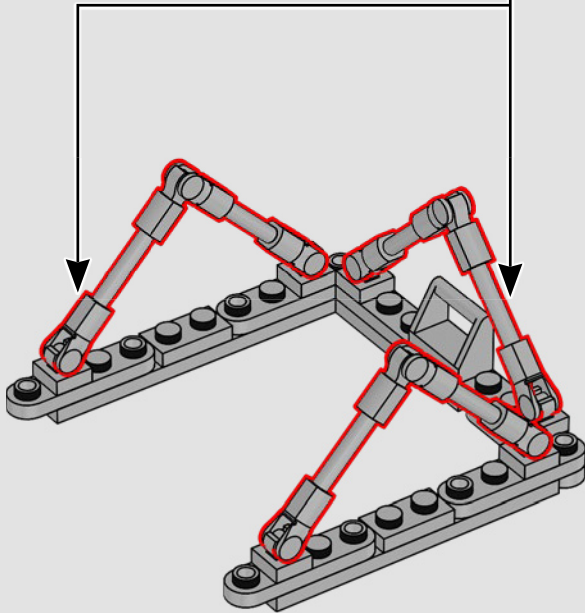
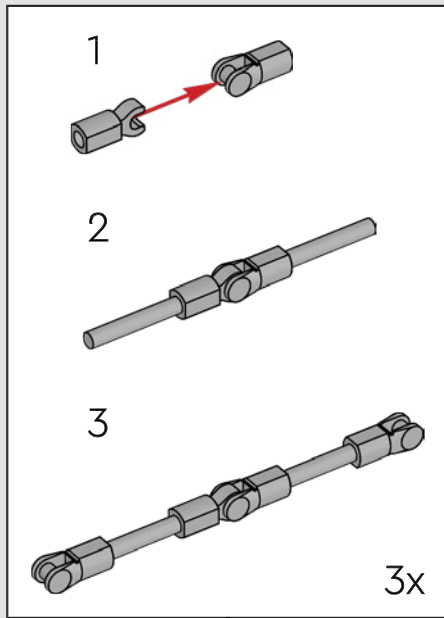

333

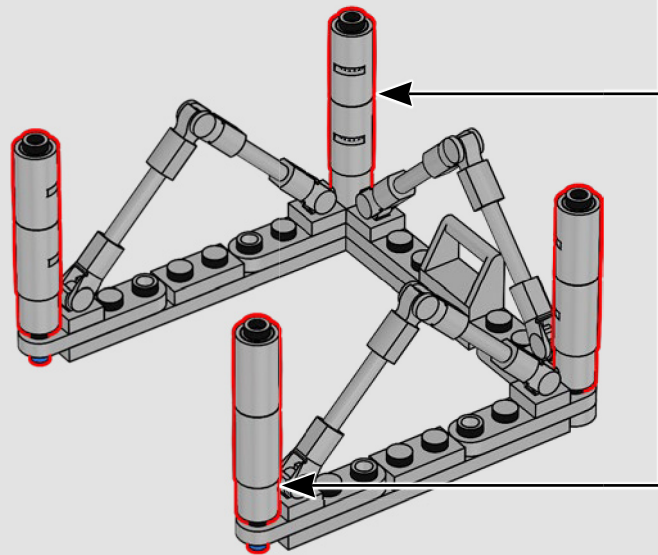
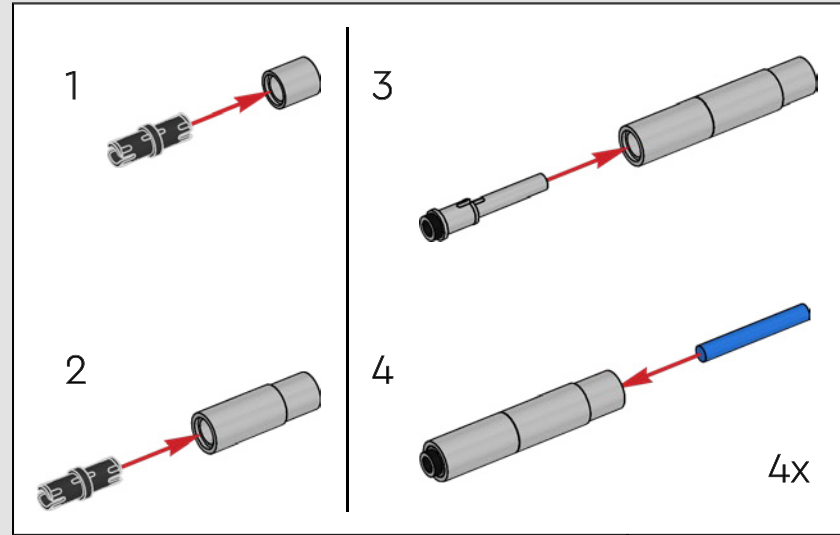



1x

334

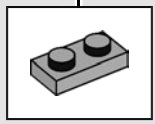
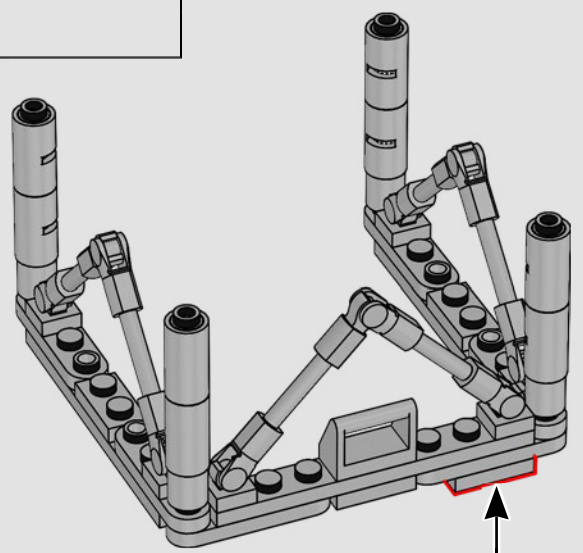
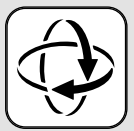

1x



1x

335

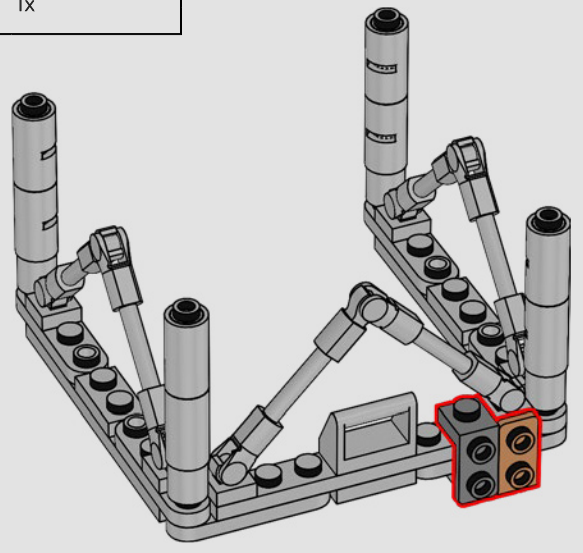

336

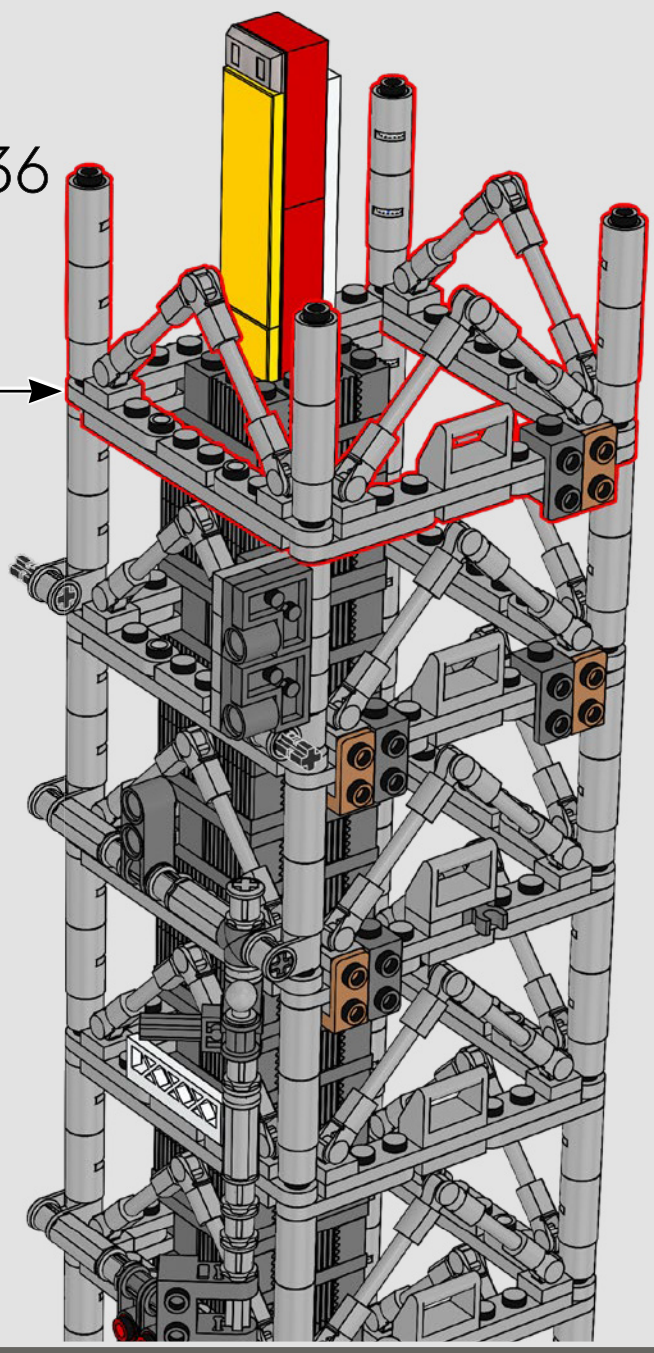

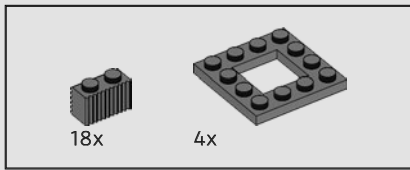

337

1

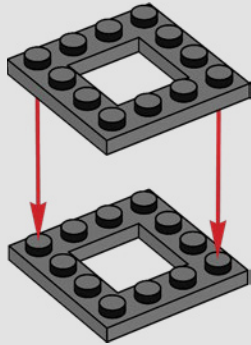

2

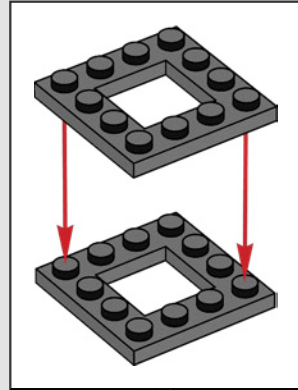
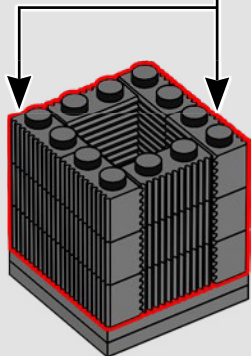
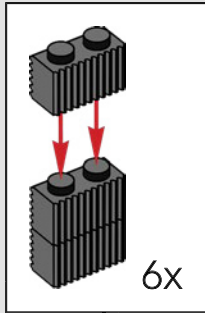

3

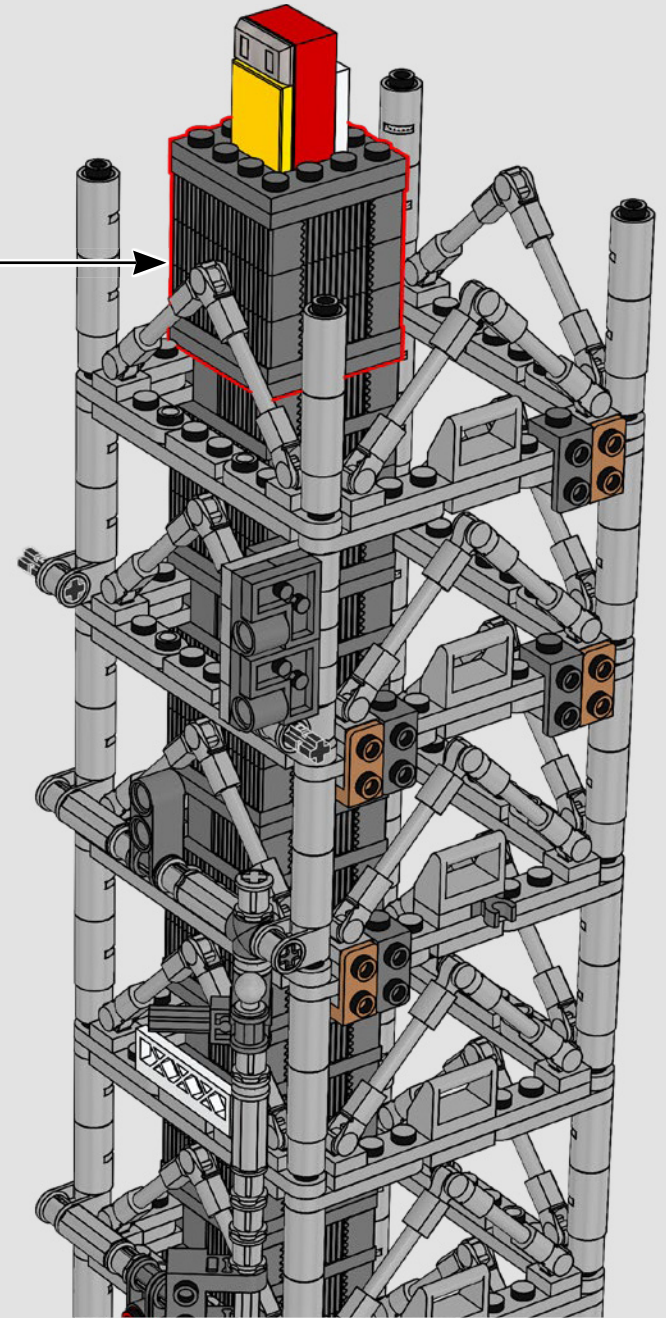
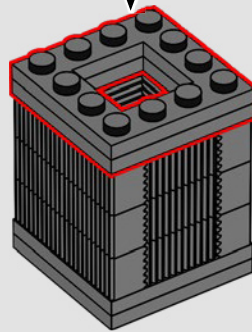

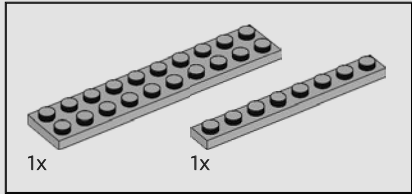
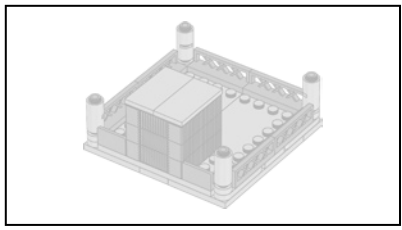

338

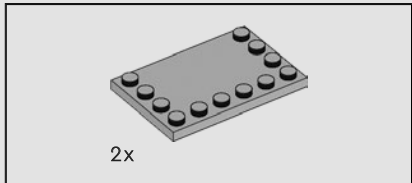
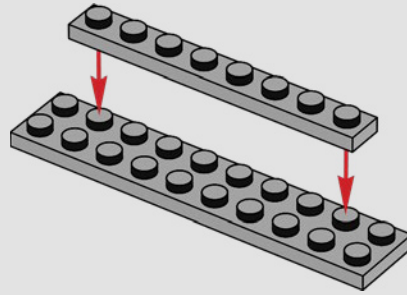

339

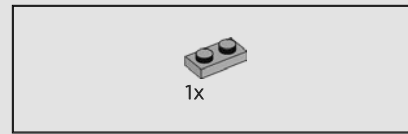
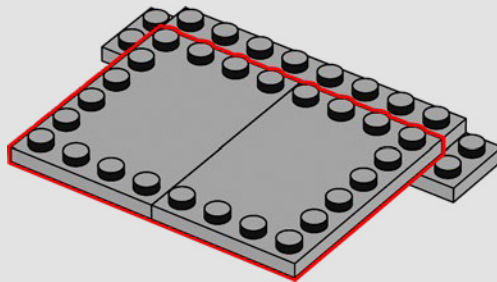

340

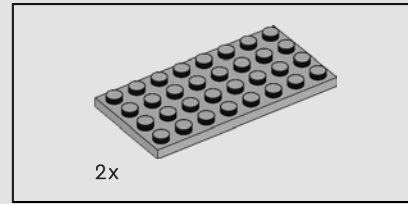
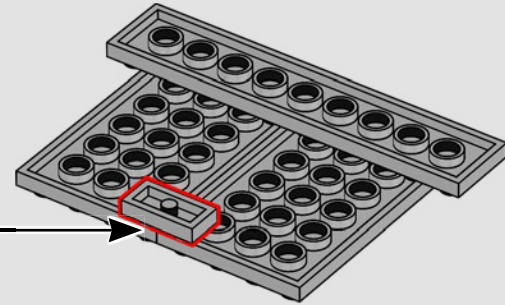
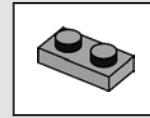
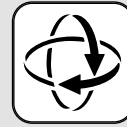

341

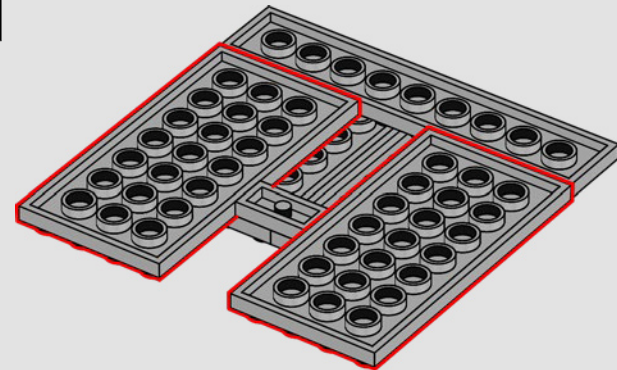

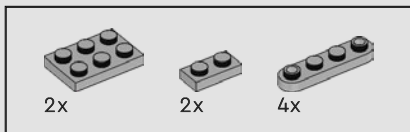

342

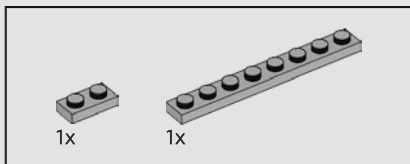
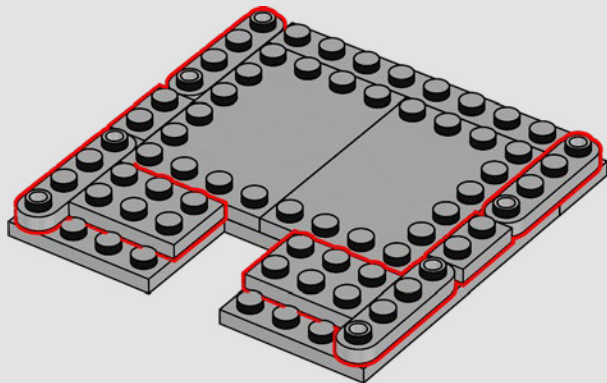
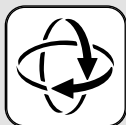

343

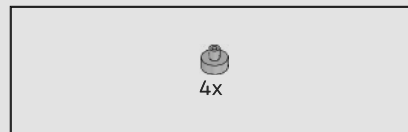
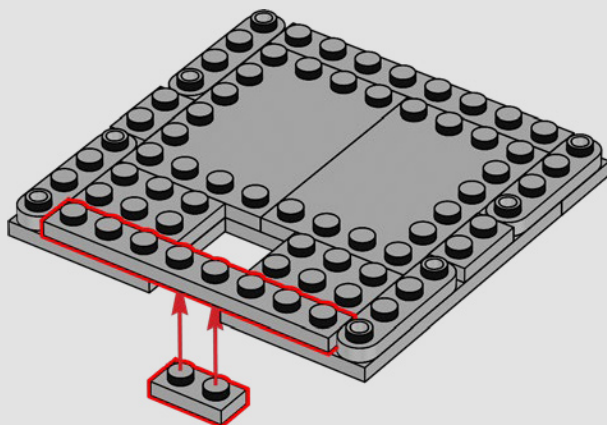

344

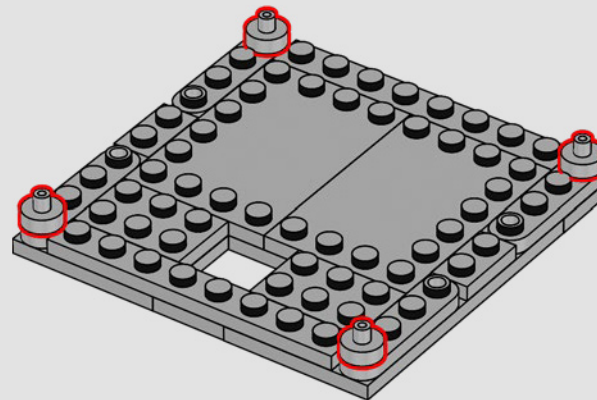

345

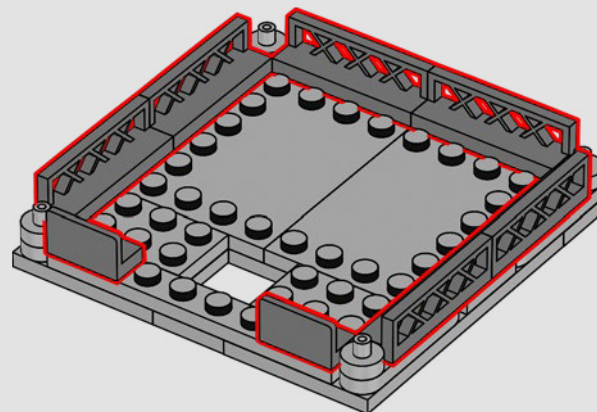



5x

346

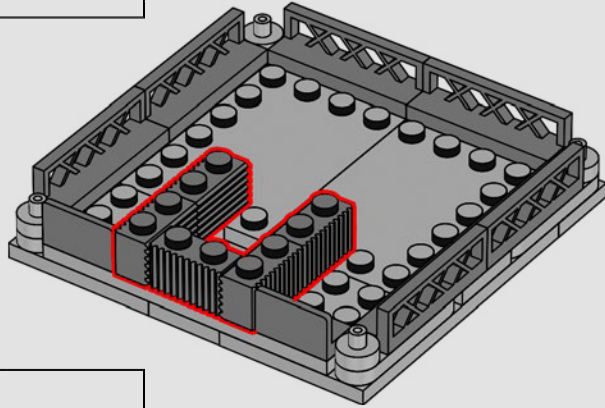

5x



1x



1x



2x

347

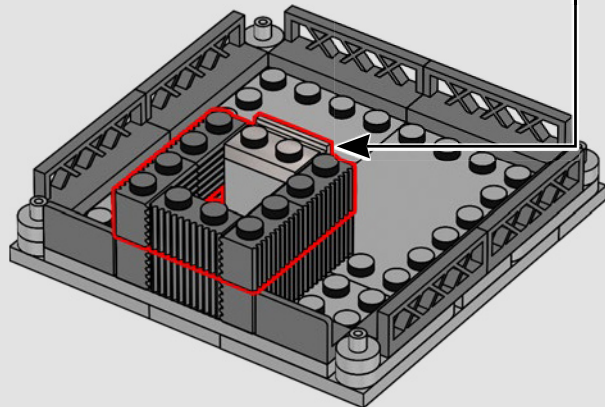
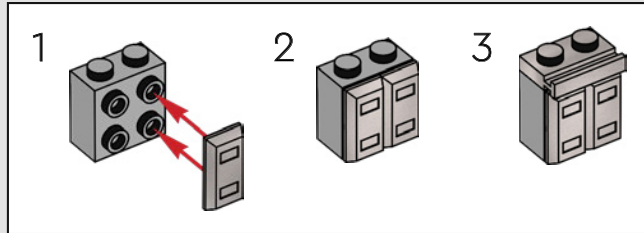

6x

348

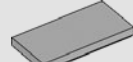
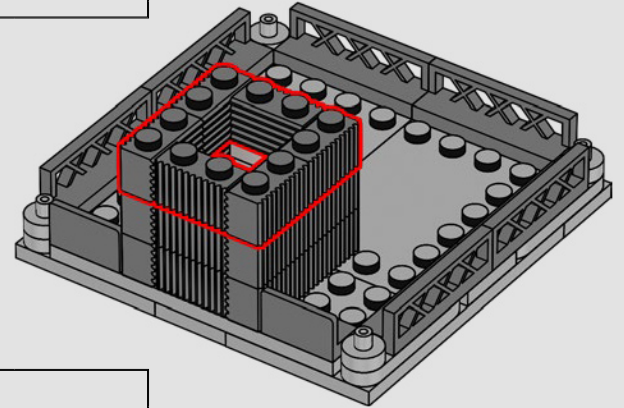

2x

349

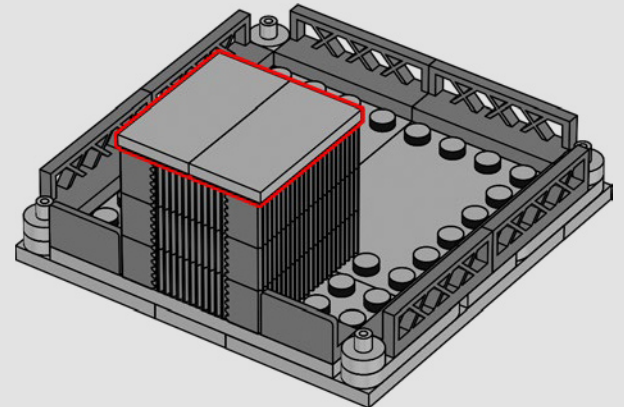



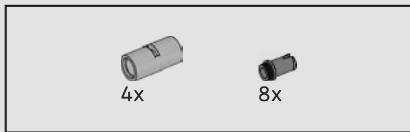

350

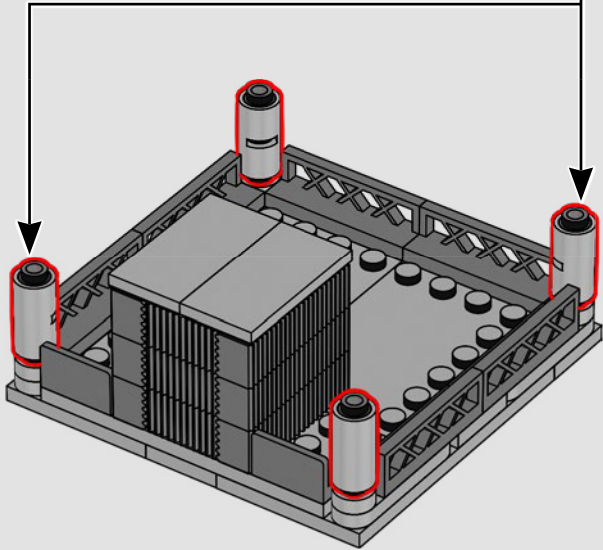
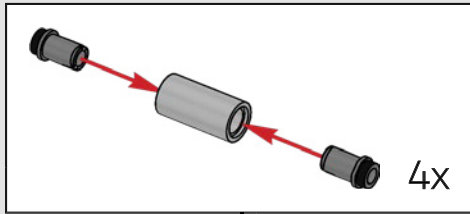

351

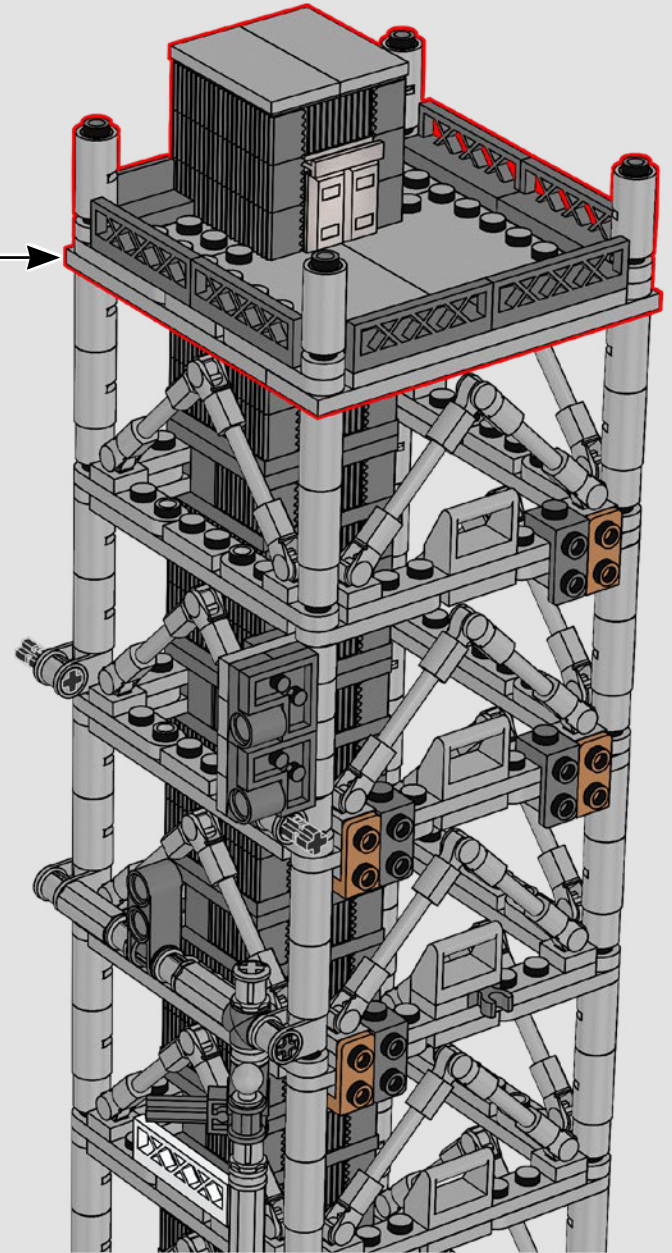

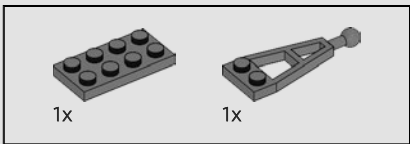
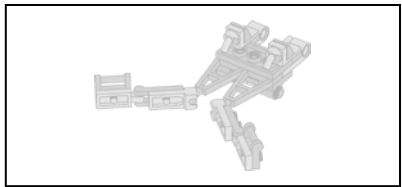

352

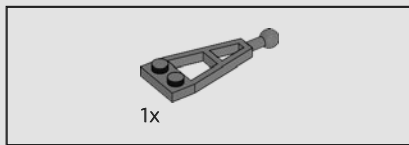
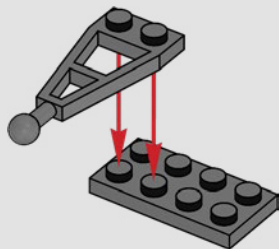

353

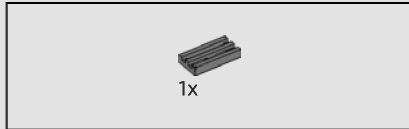
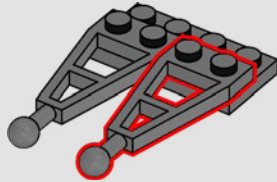

354

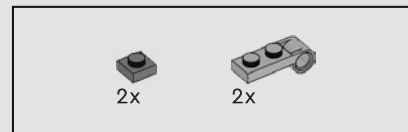
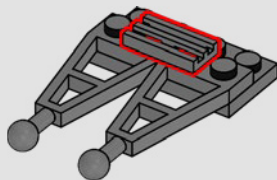

355

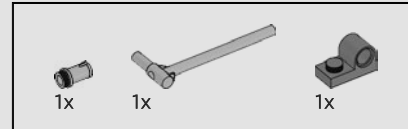
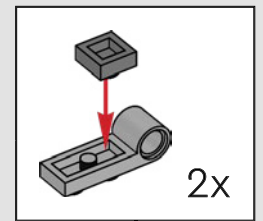
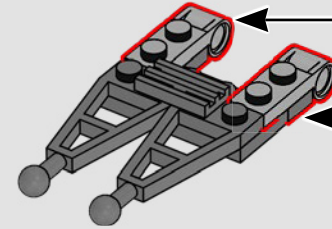

356

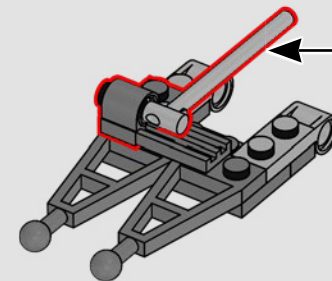
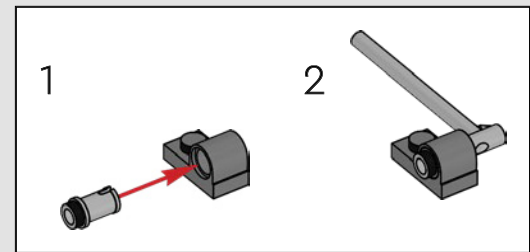

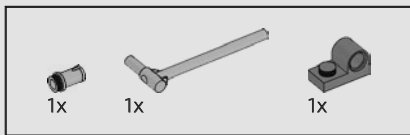

357

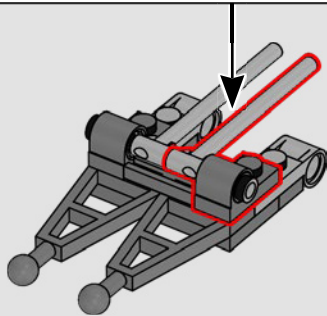
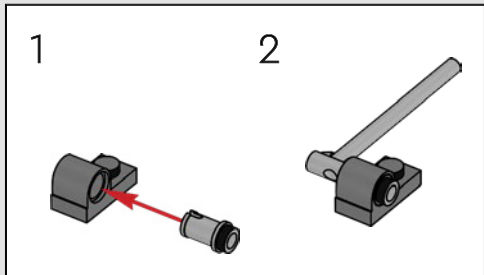

358

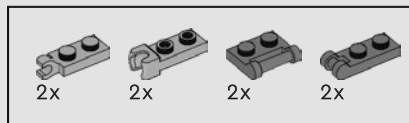
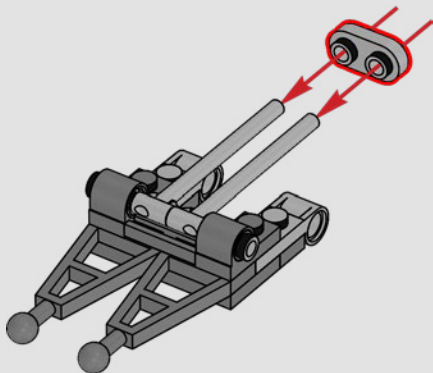

359

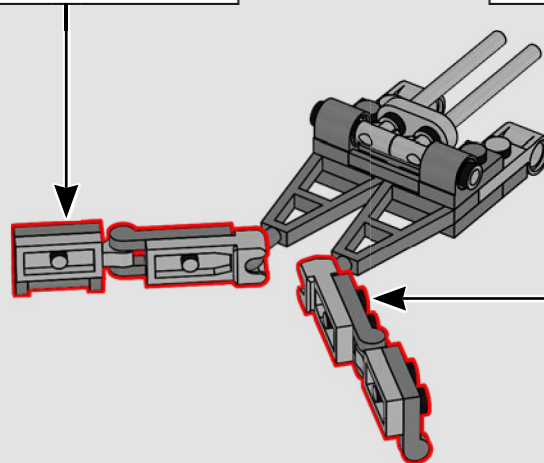
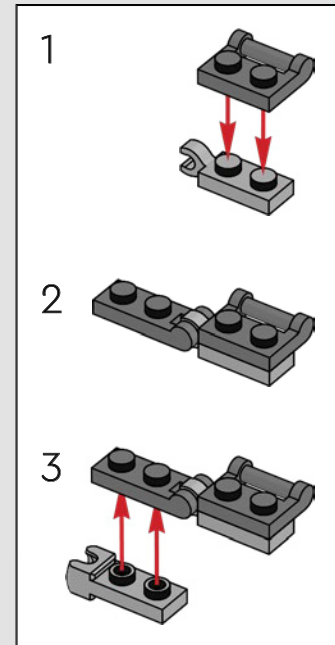
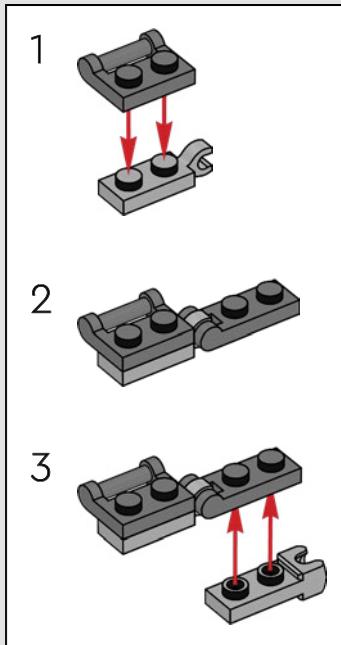



360

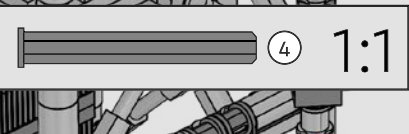
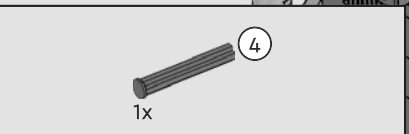
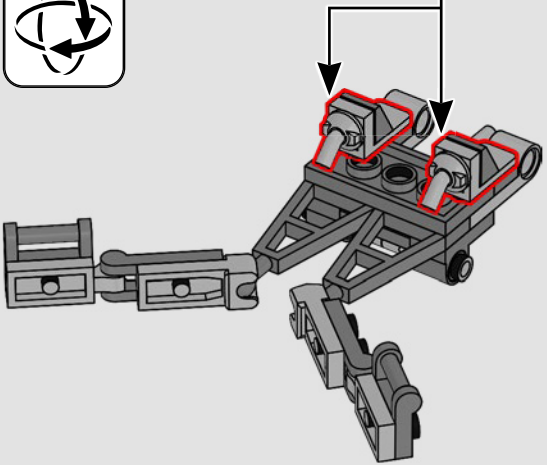
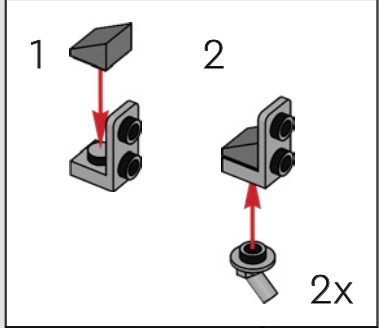

361

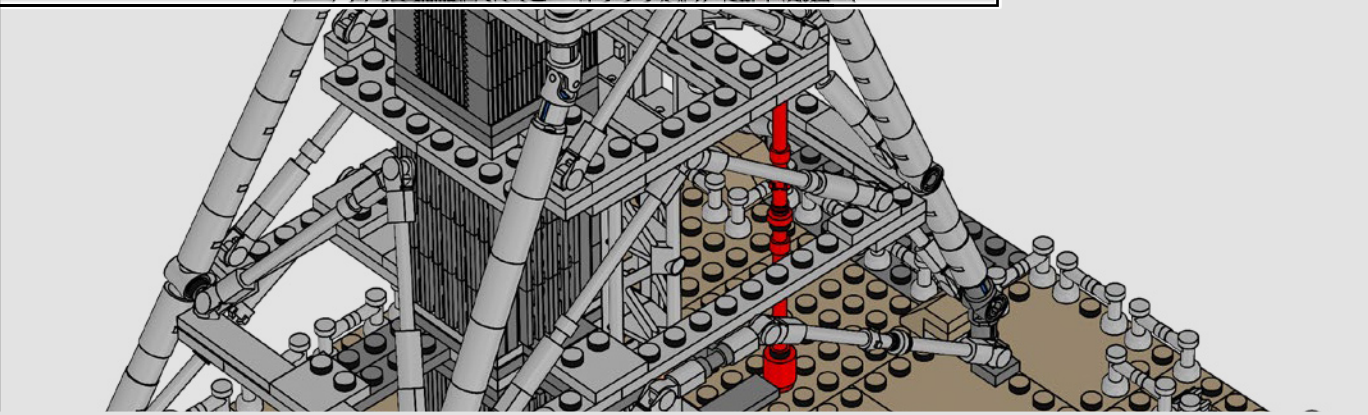
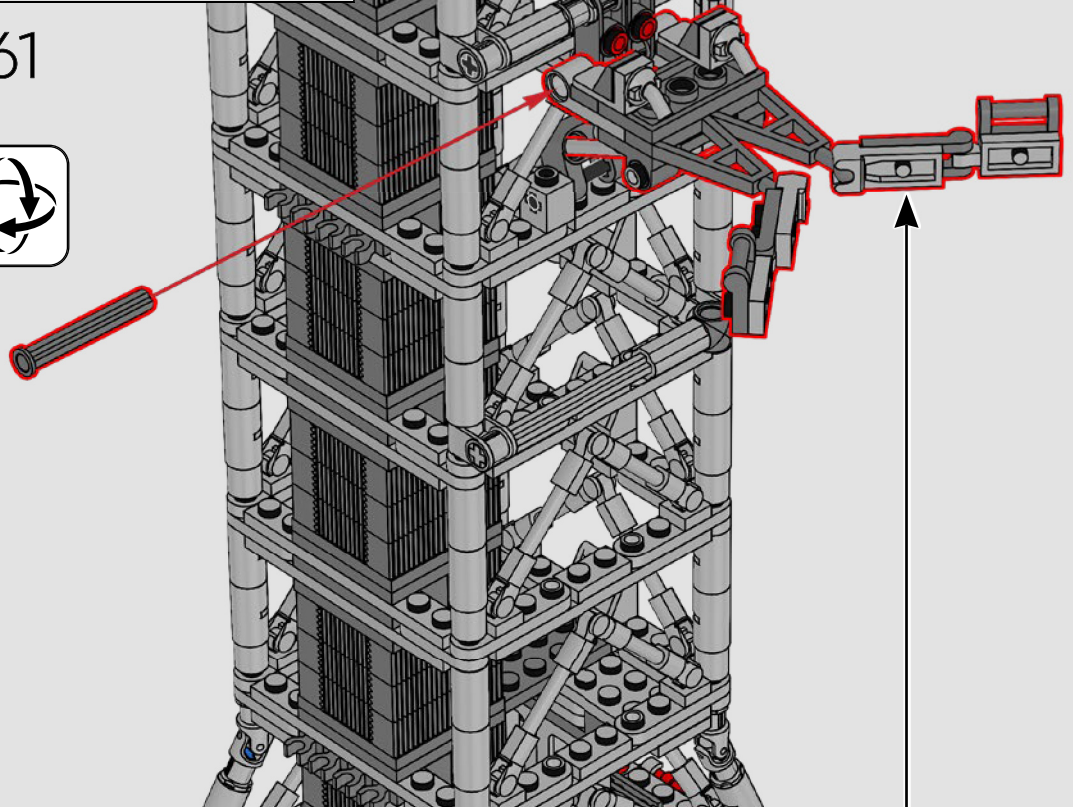

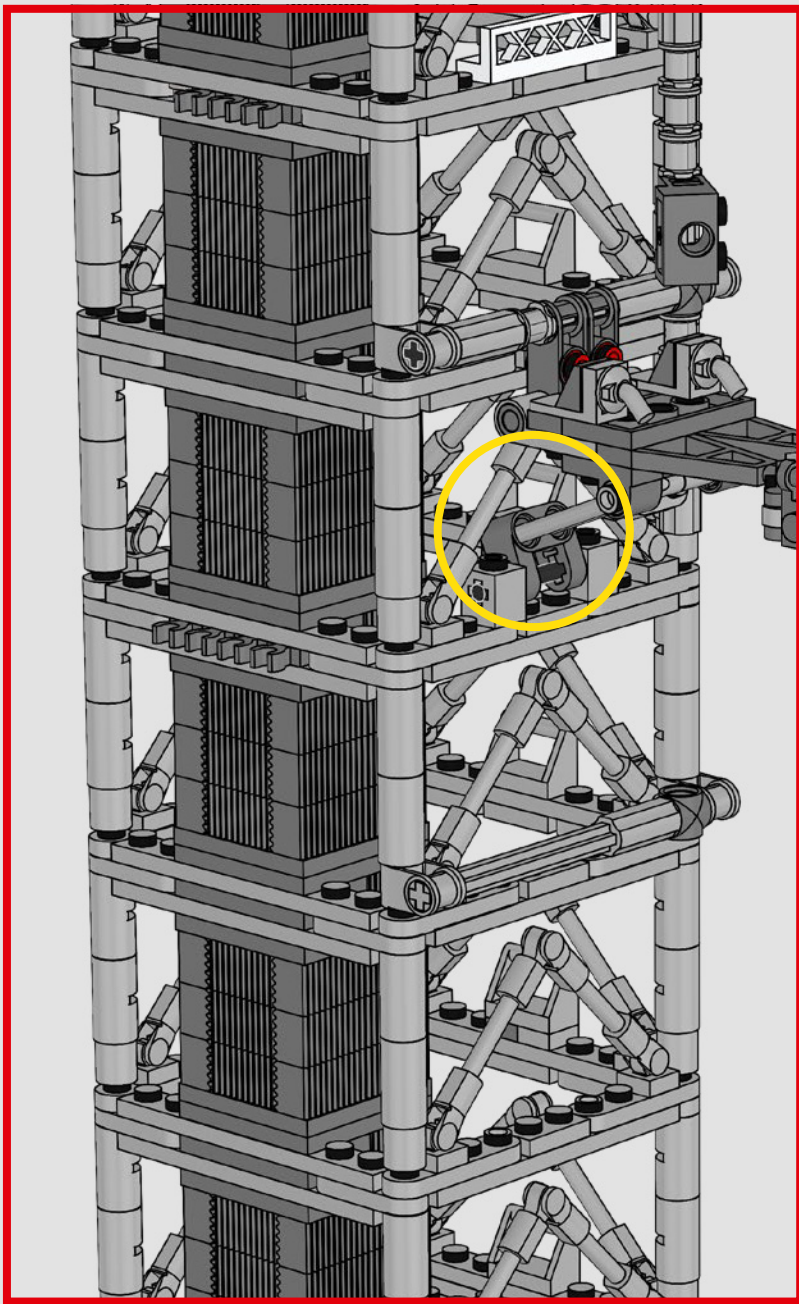

362

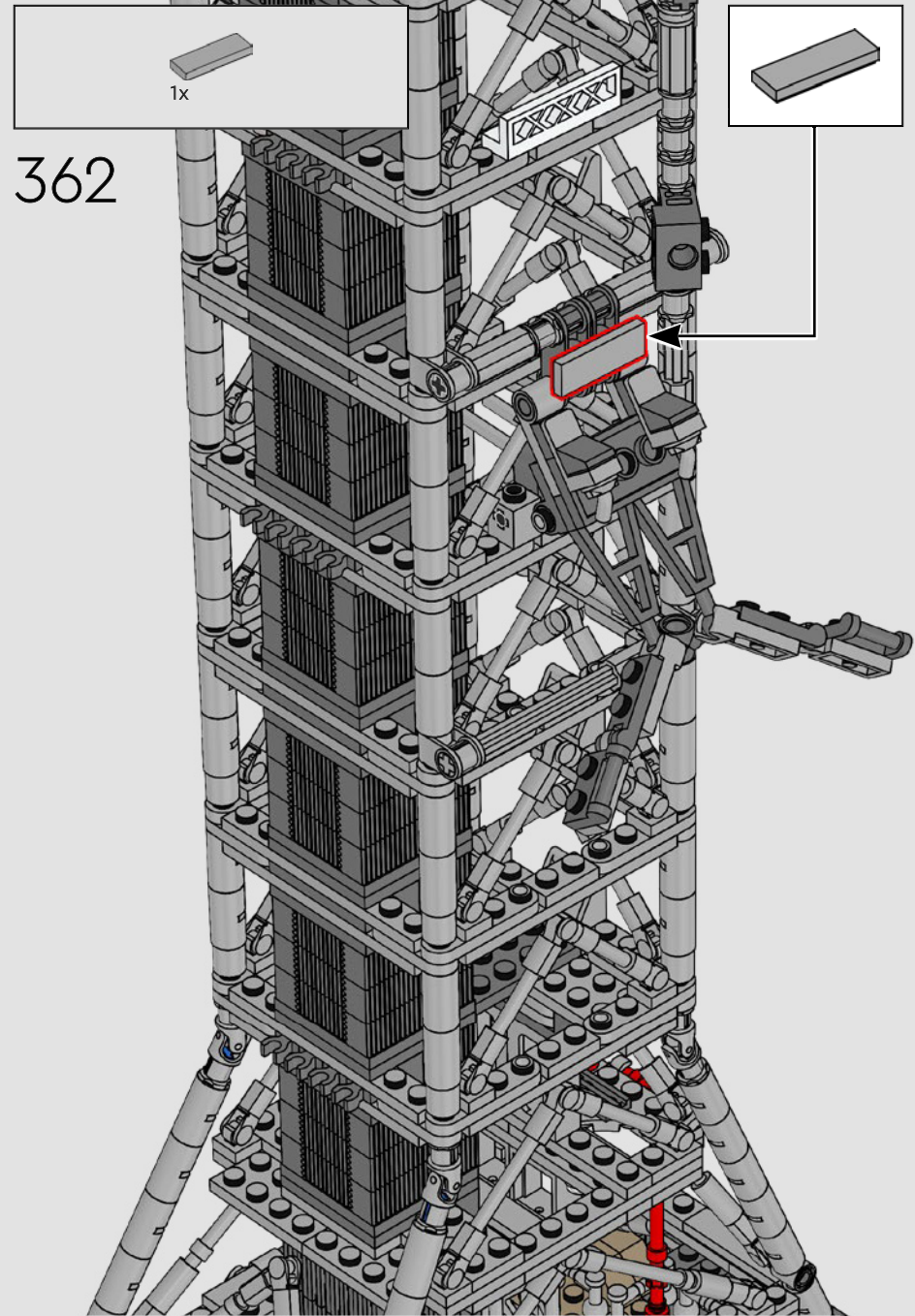

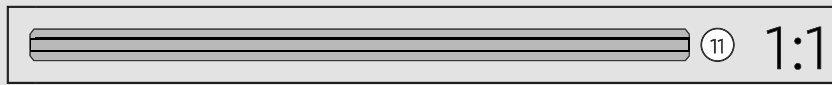
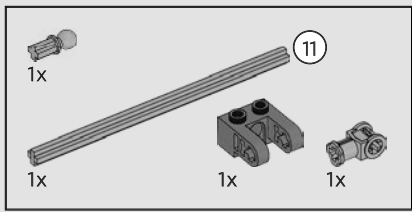

363

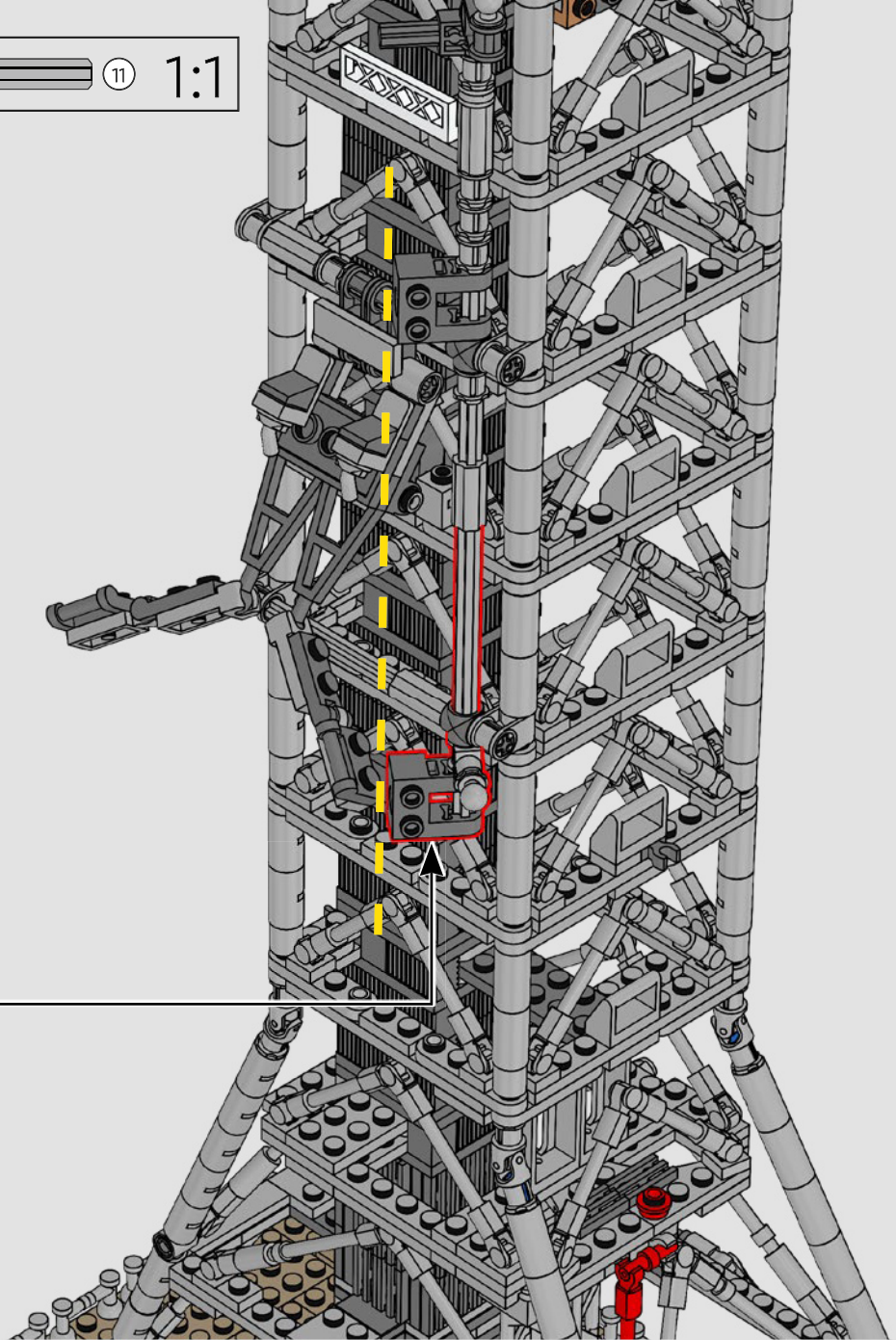
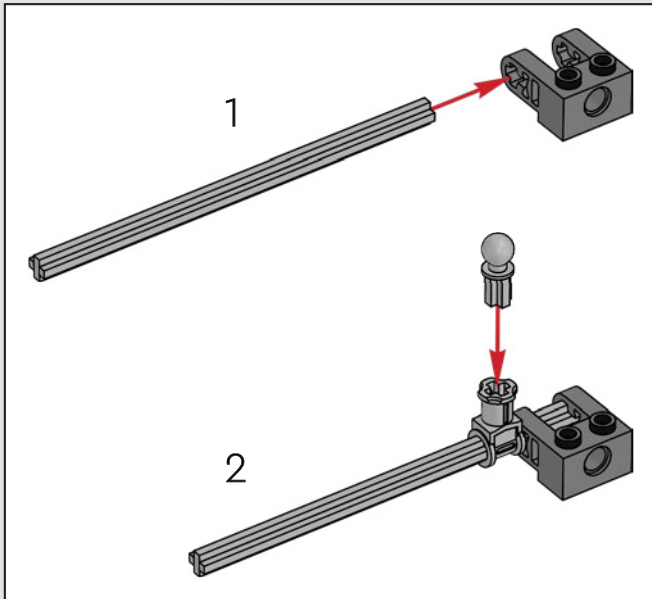

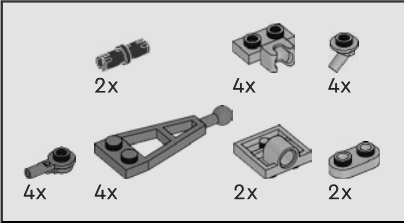
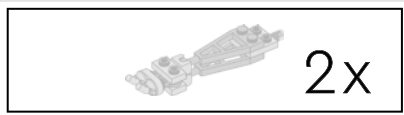

364

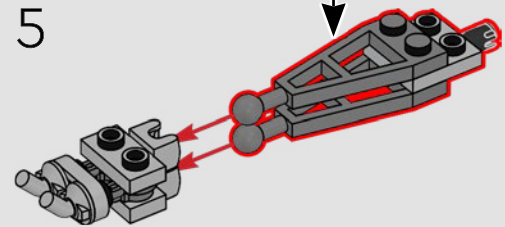
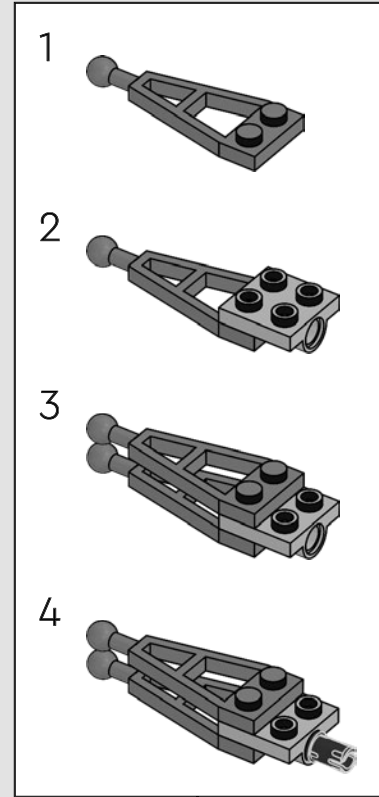
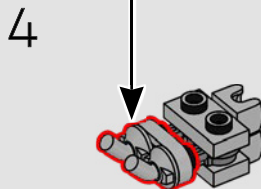
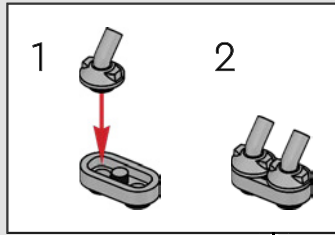
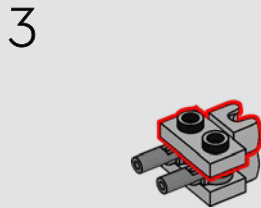
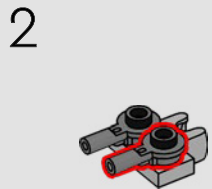
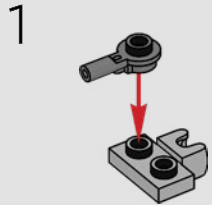

2x

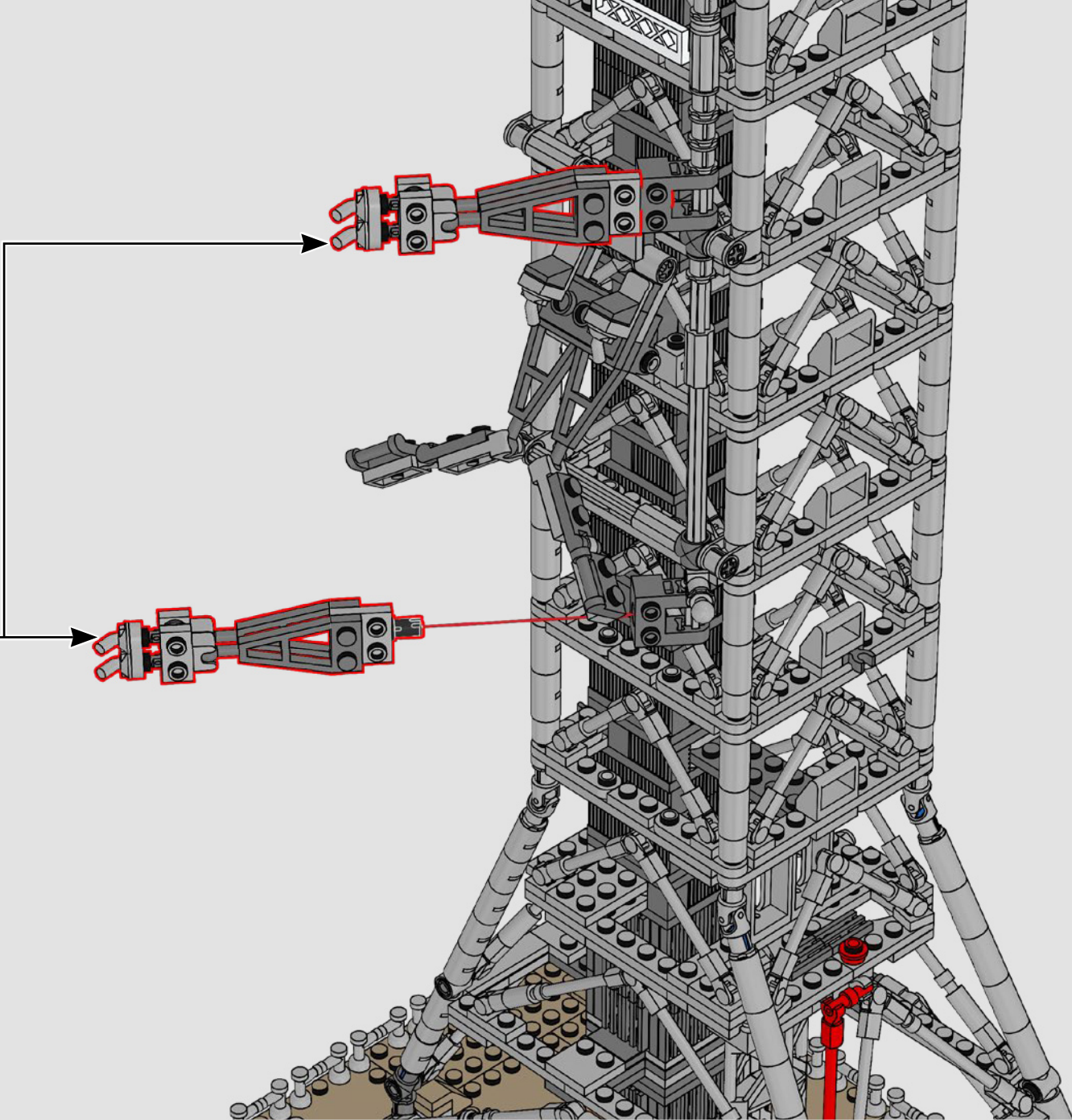



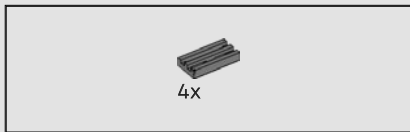

365

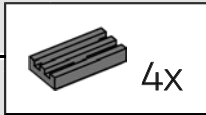
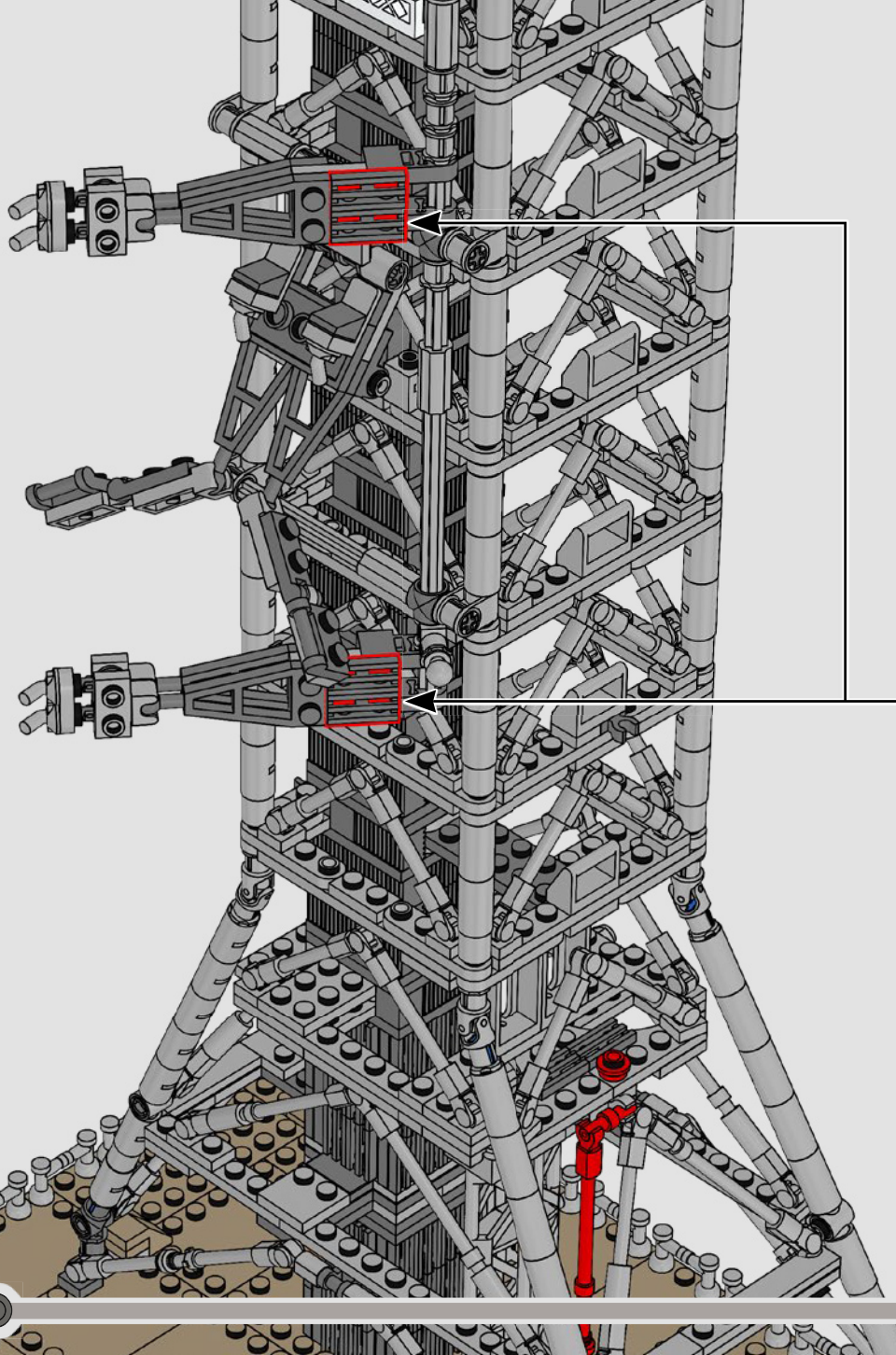

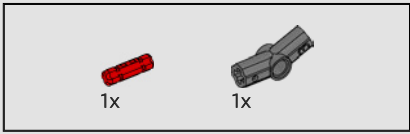
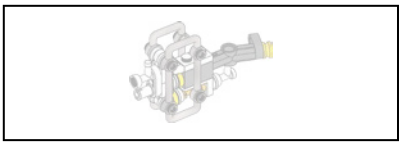

366

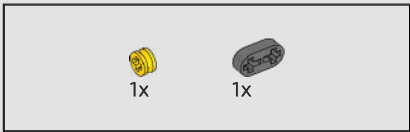
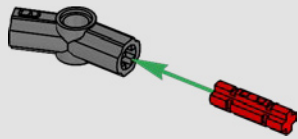

367

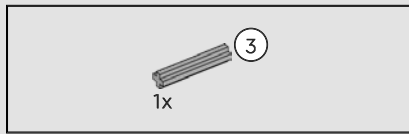
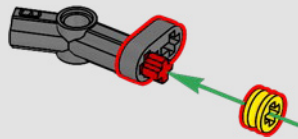

368

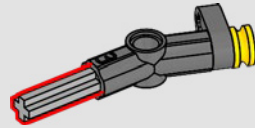

369

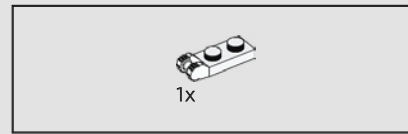
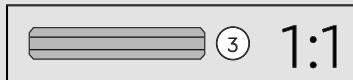
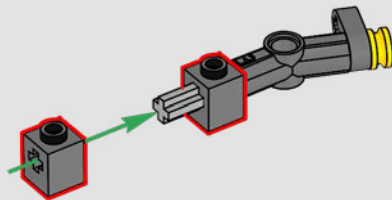

370

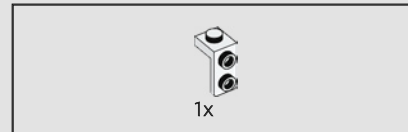
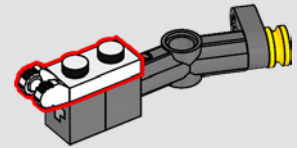

371

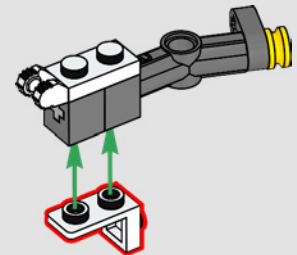



372

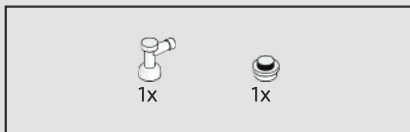
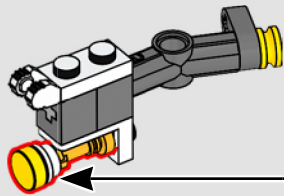
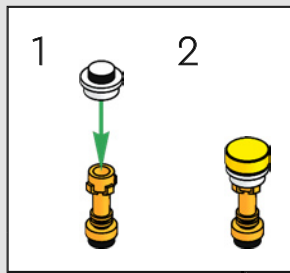

373

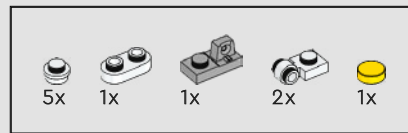
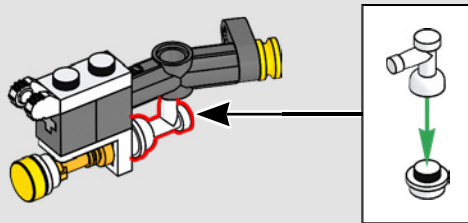

374

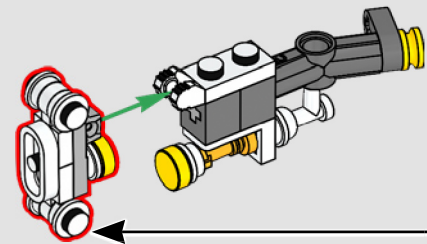
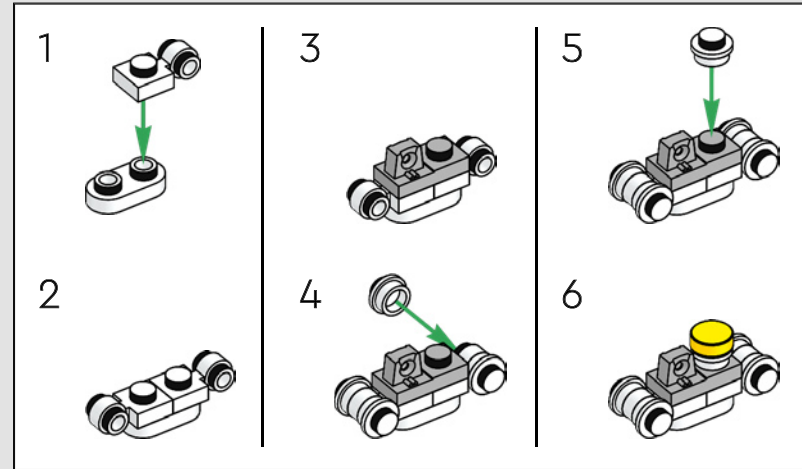

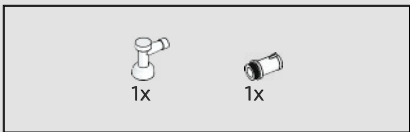

375

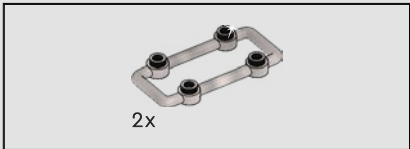
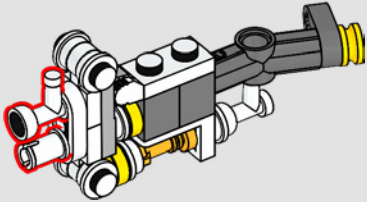

376

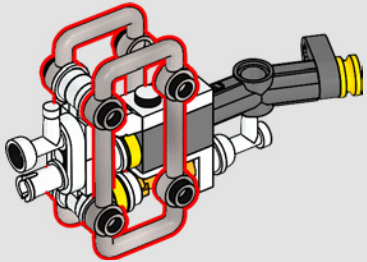

377

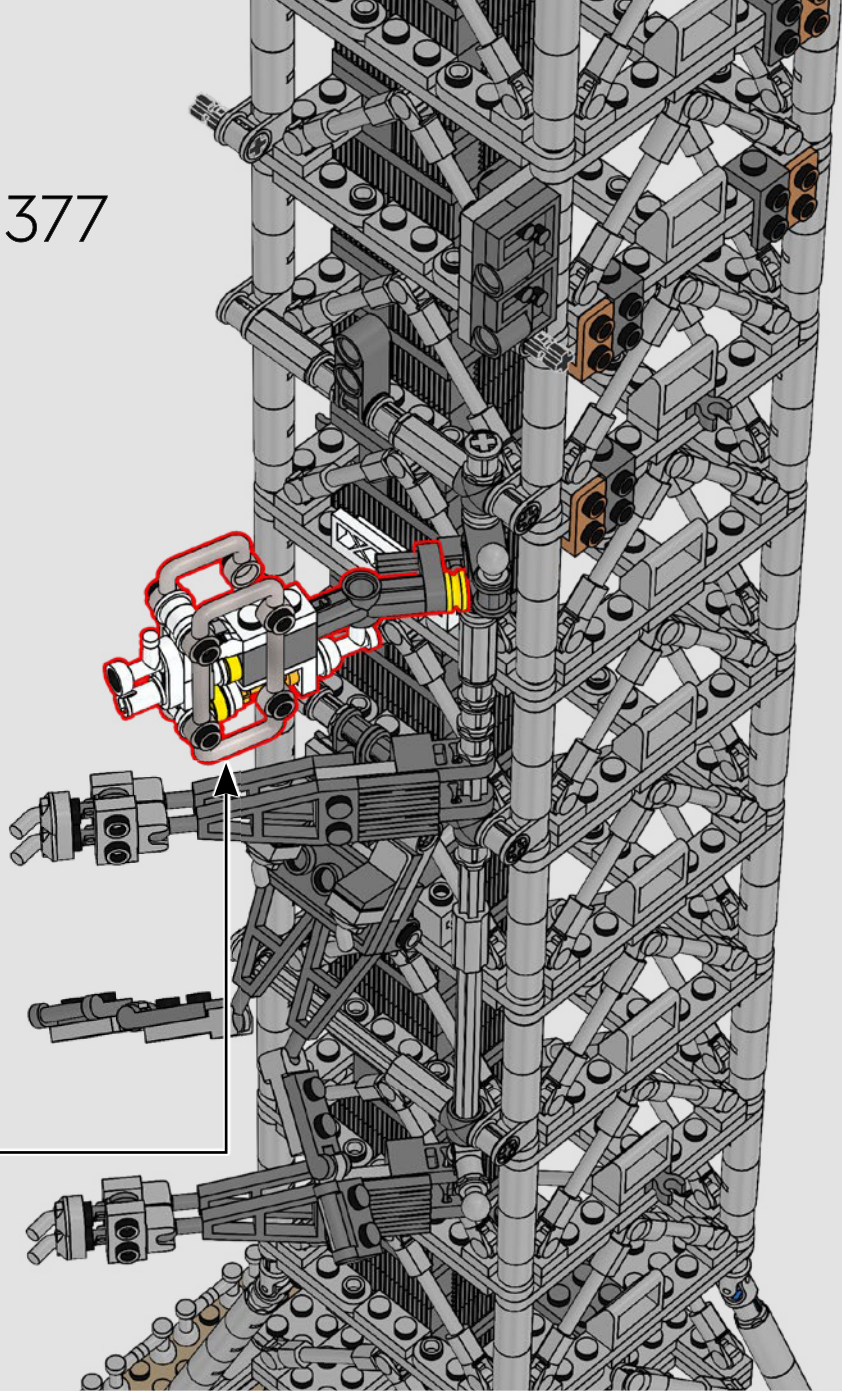

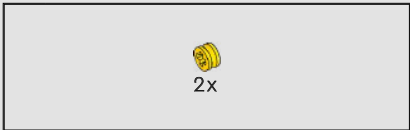

378

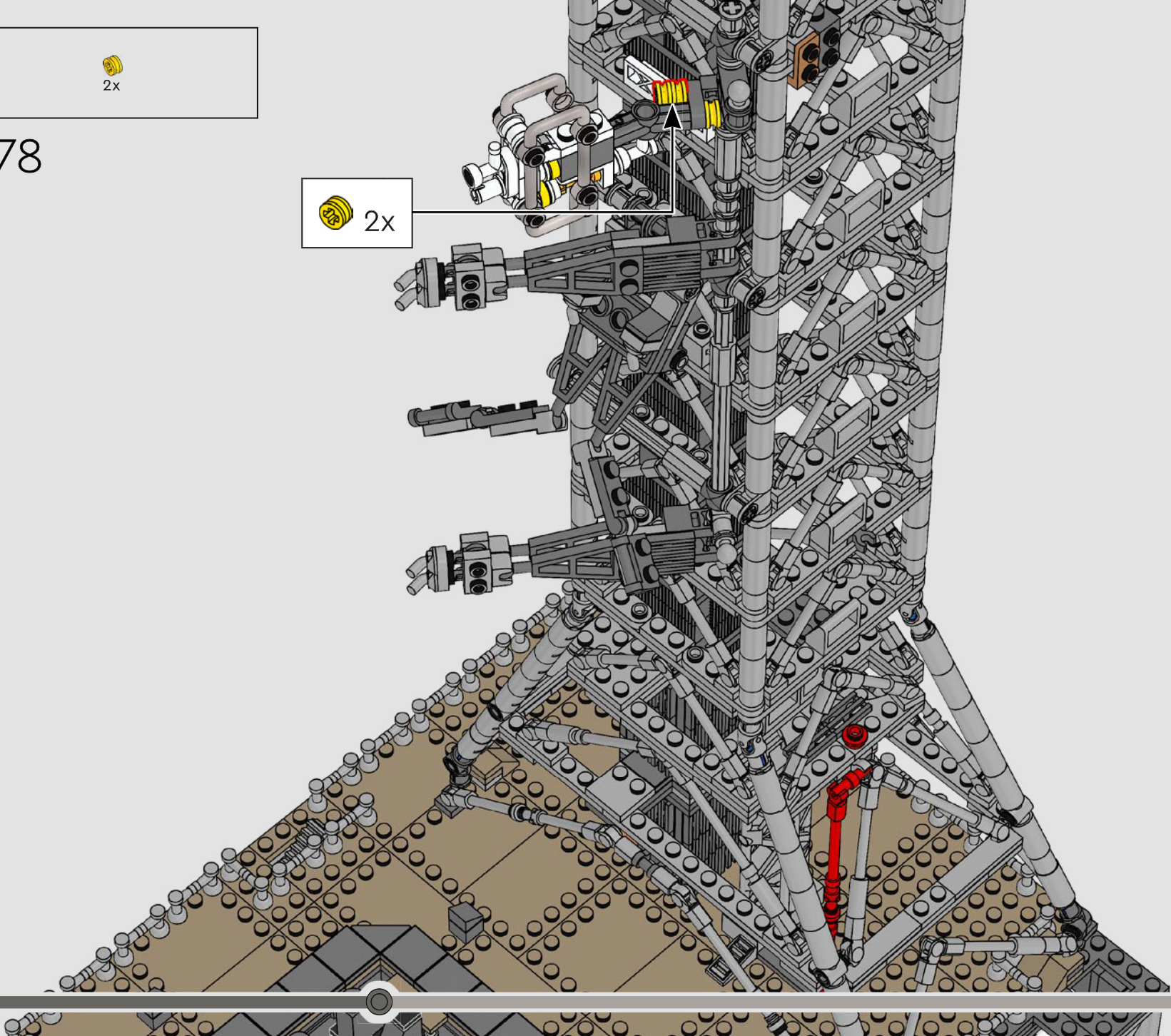

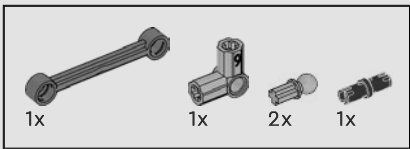

379

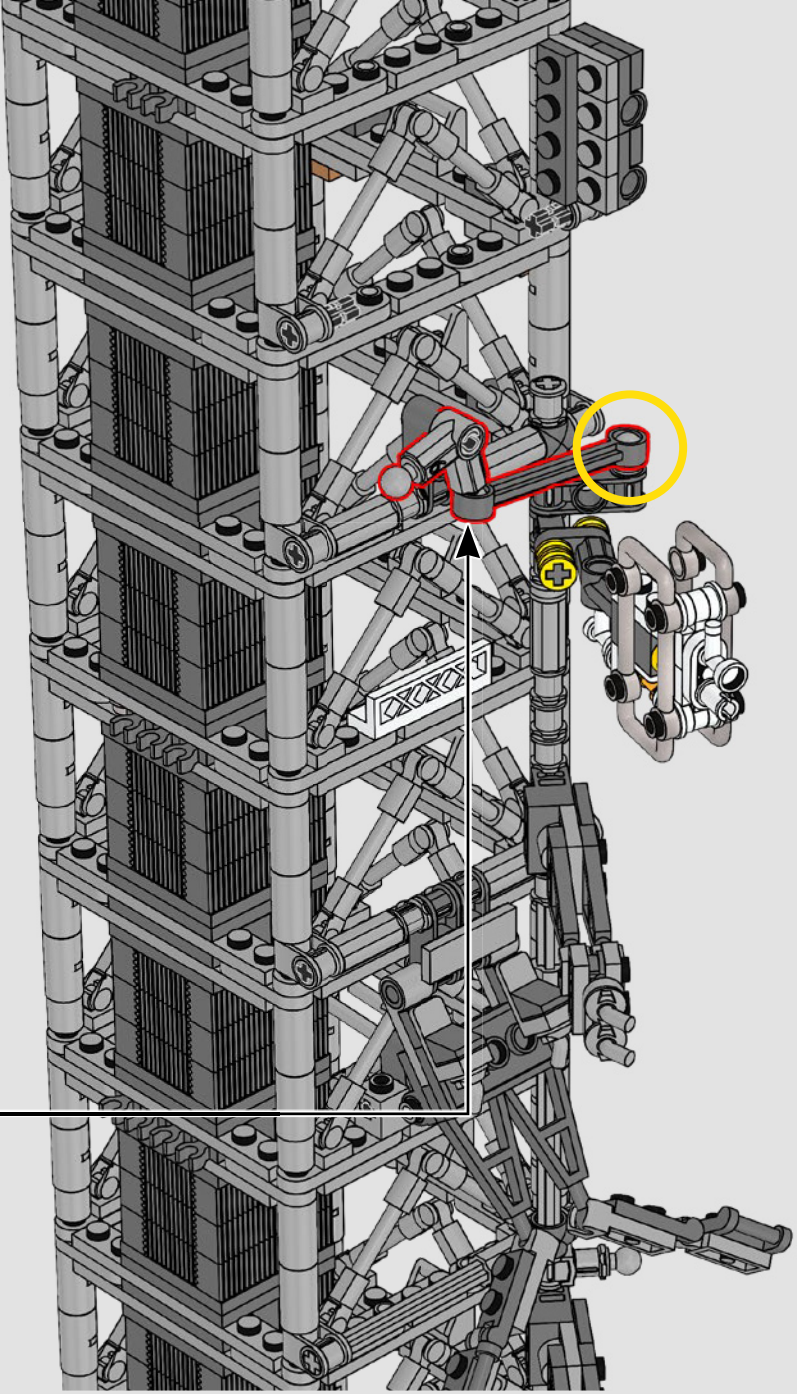
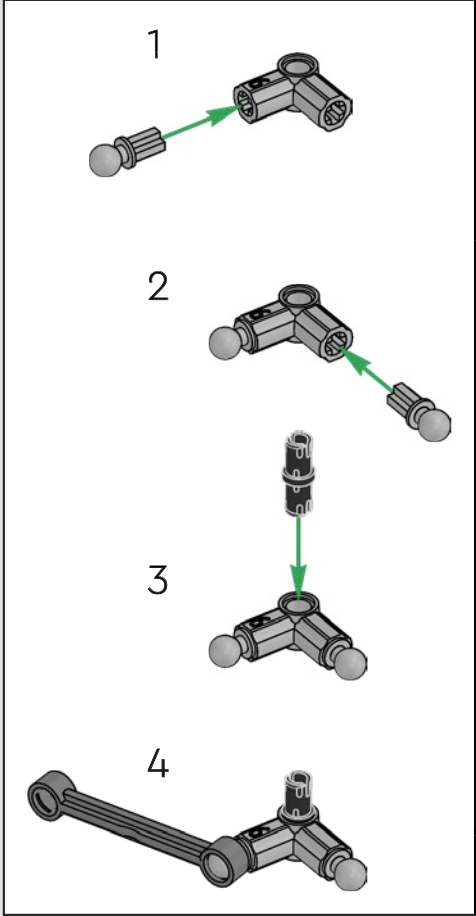

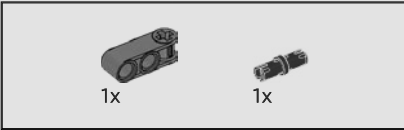
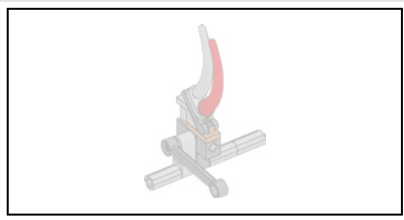

380

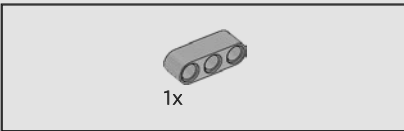
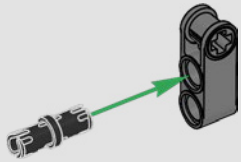

381

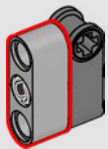

382

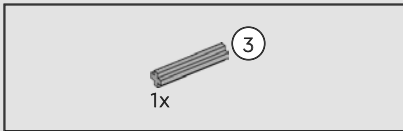
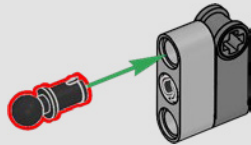

383

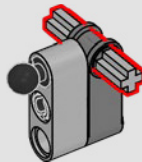

384

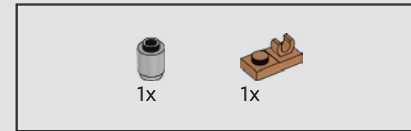
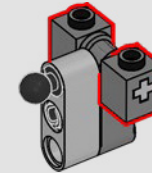

385

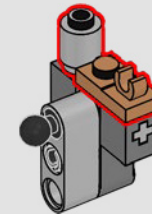

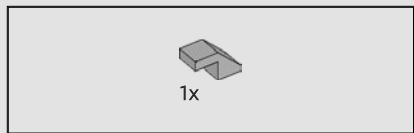

386

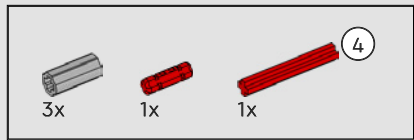
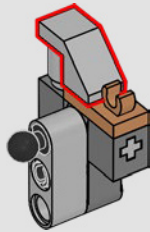

387

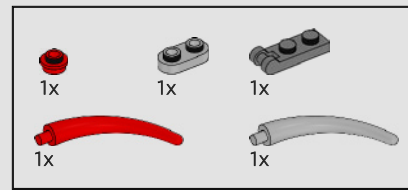
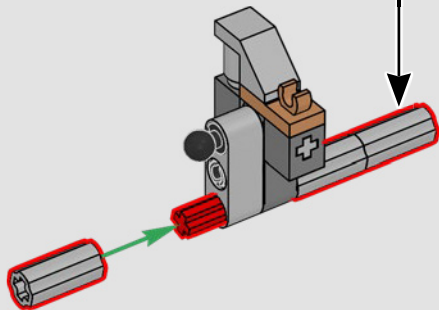
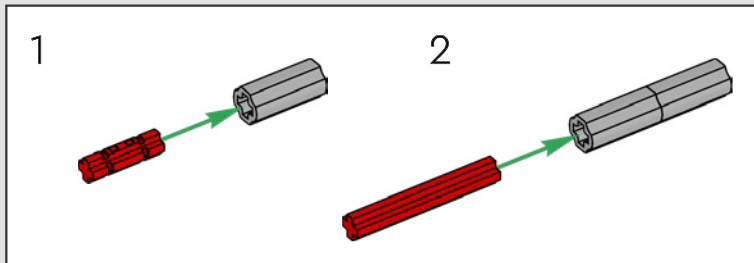

388

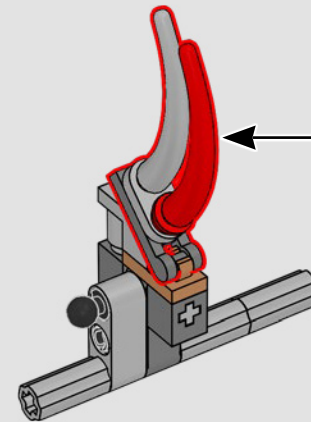
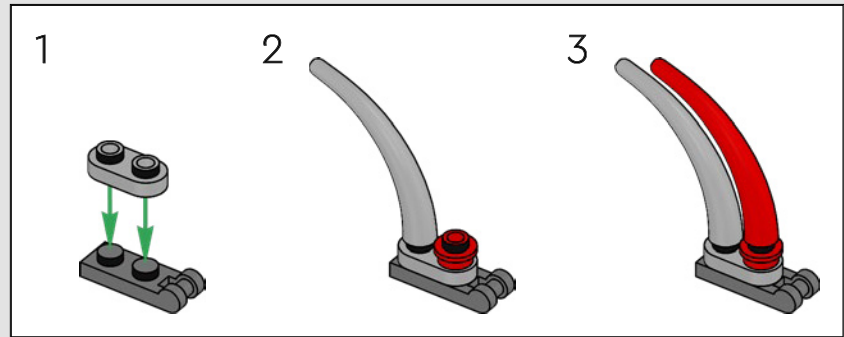



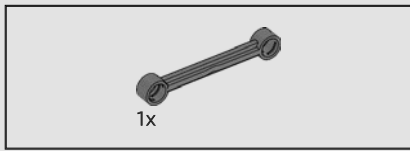

389

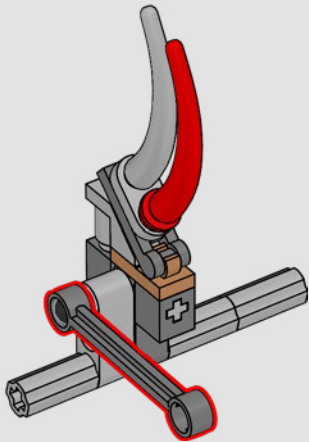

390

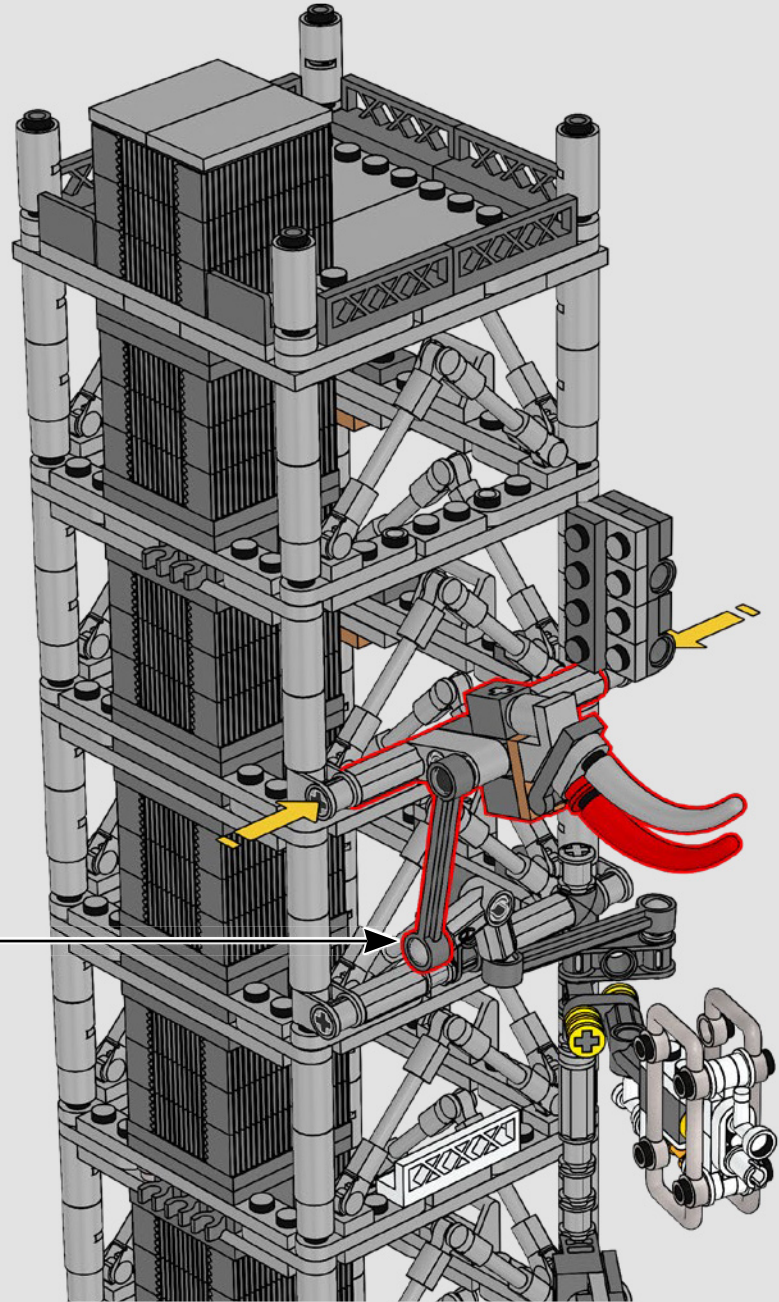

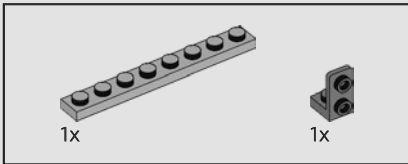
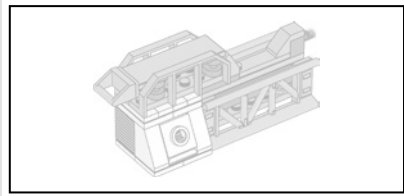

391

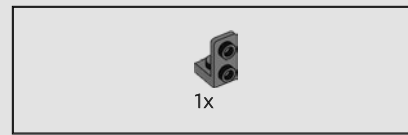
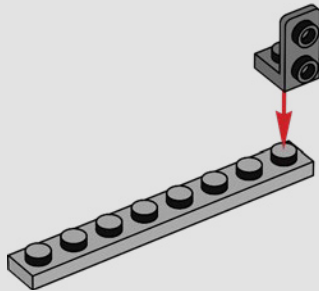

392

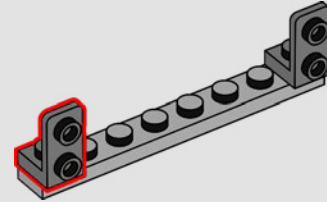

393

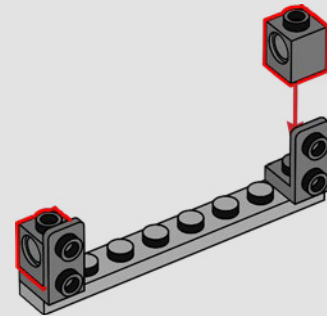

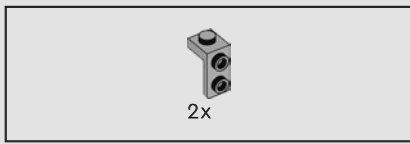

394

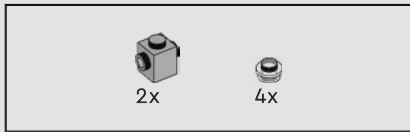
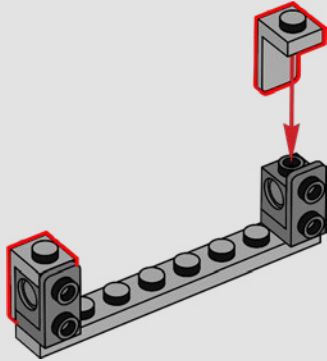

395

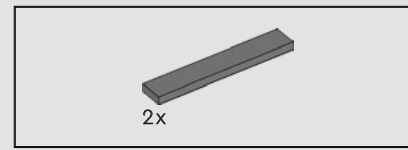
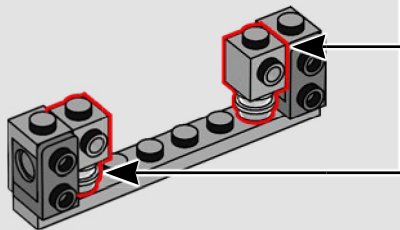
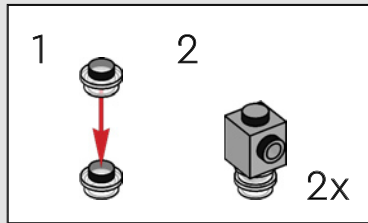

396

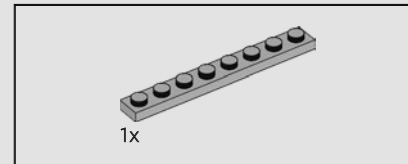
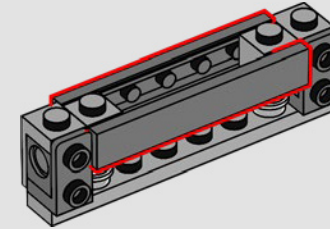

397

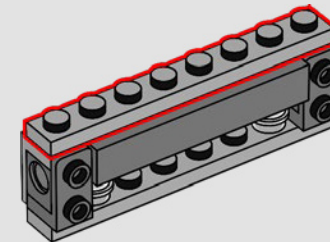

2x

398

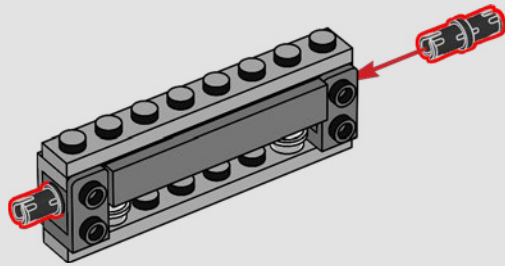

1x

1x

400

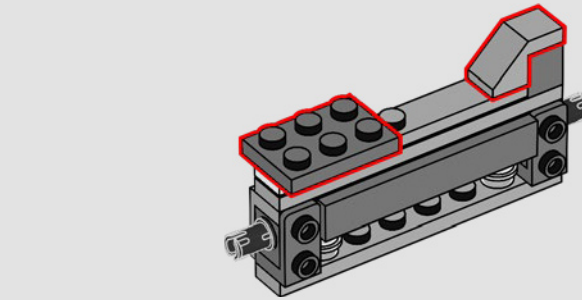

1x

1x

1x

399

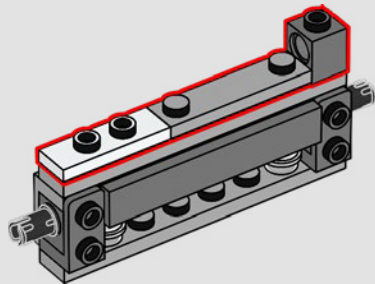

1x

1x

401

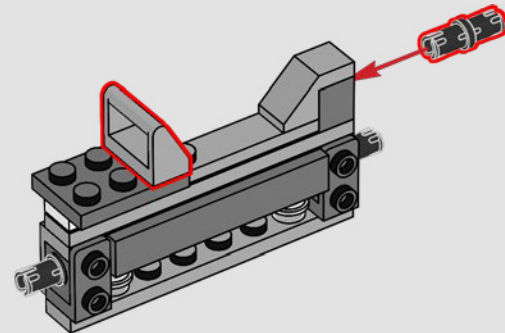

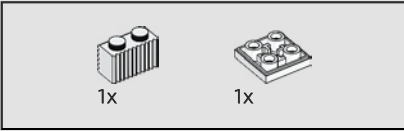
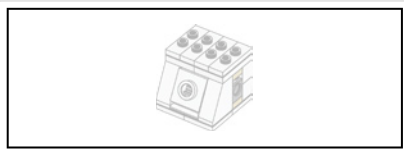

402

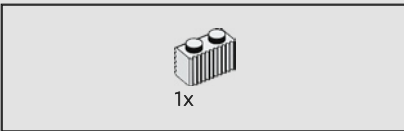
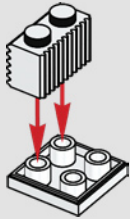

403

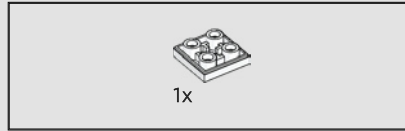
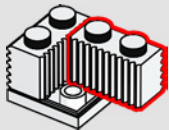

404

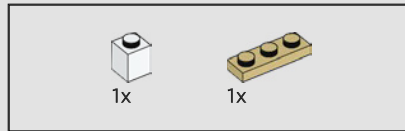
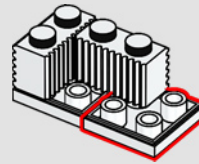

405

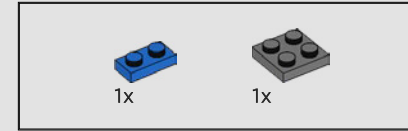
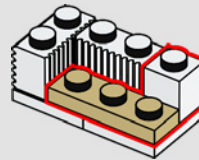

406

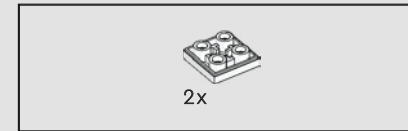
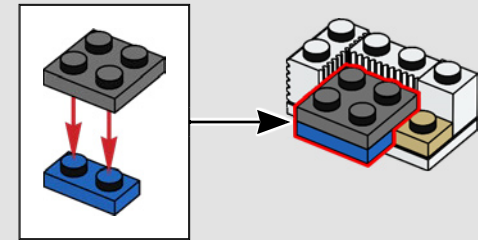

407

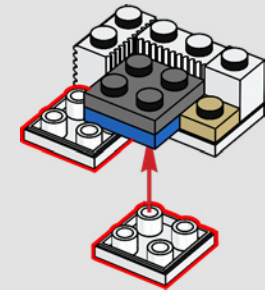

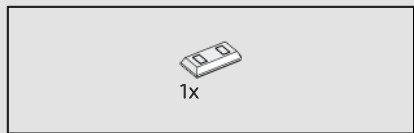

408

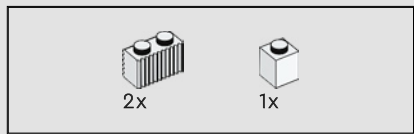
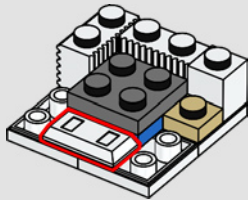

409

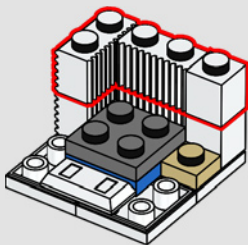

410

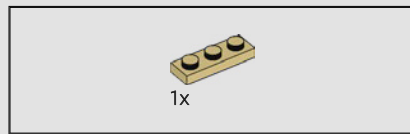
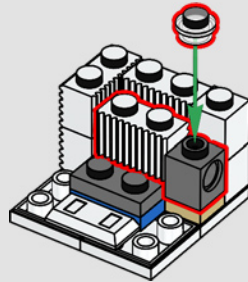

411

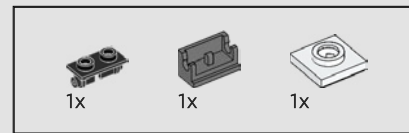
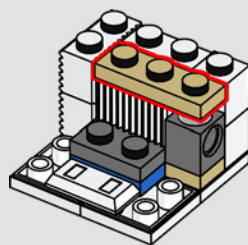

412

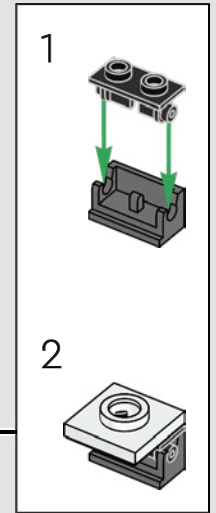
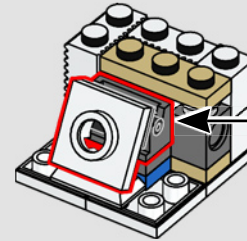

413

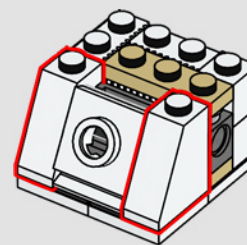

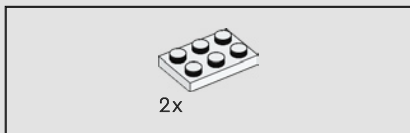

414

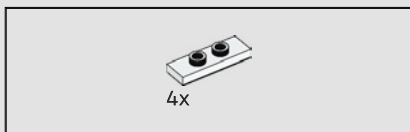
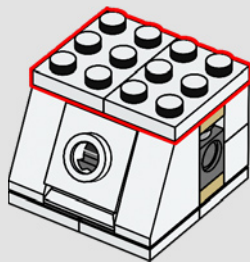

415



416

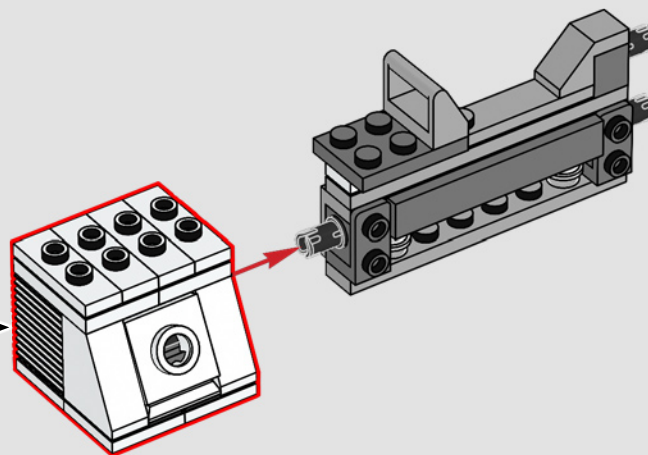

A new 2x2 turntable element was used to make the hatch on the crew bridge.

Un nouvel élément de table tournante 2x2 a été utilisé pour fabriquer l'écotille du pont de l'équipage.

Se utilizó un nuevo elemento giratorio 2x2 para recrear la escotilla del puente de la tripulación.

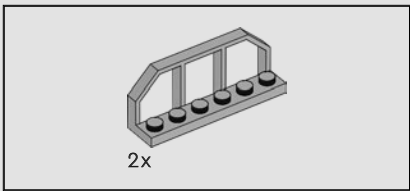

417

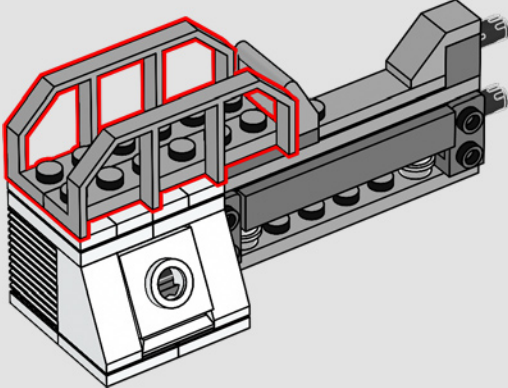

418

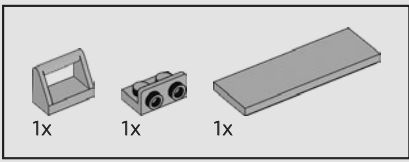
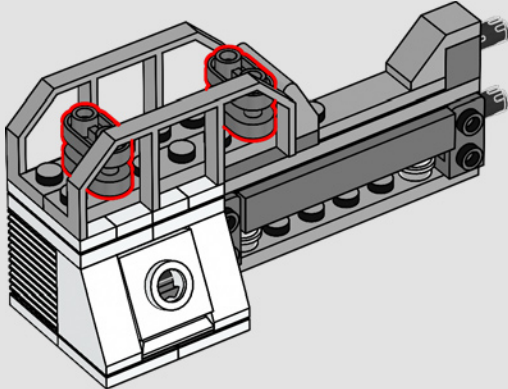

419

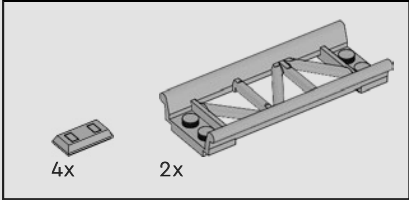
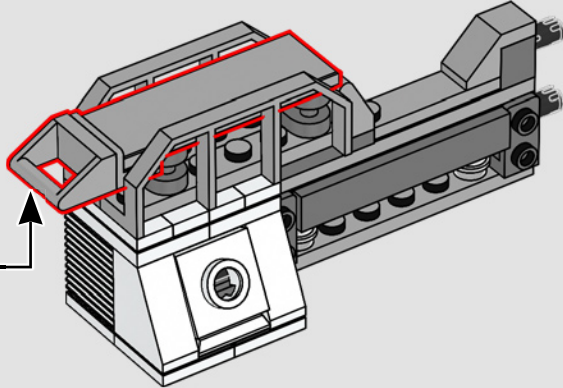
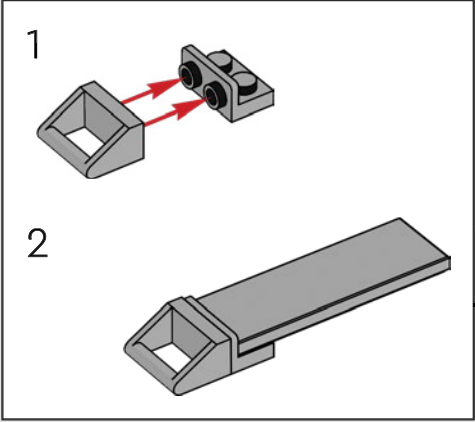

420

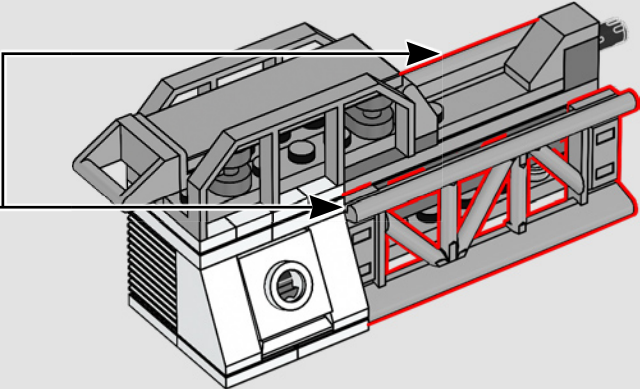
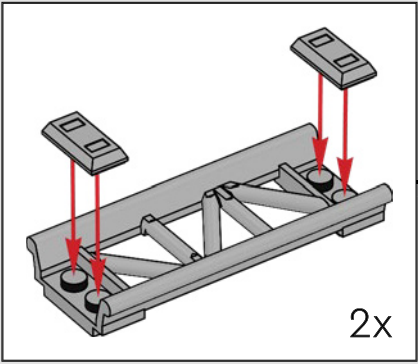



421

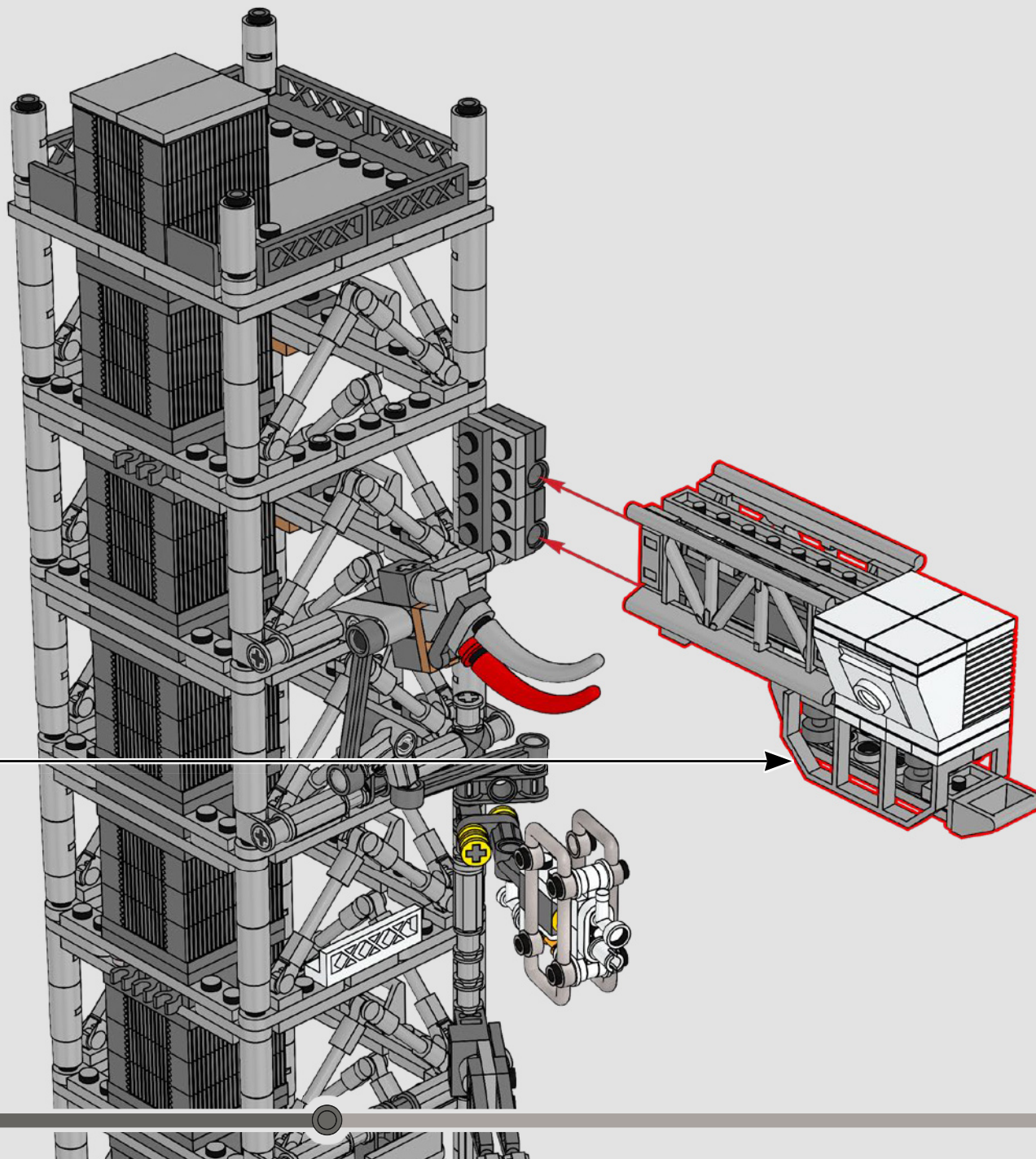

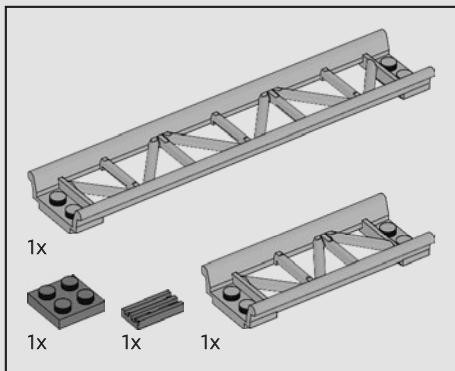

422

1

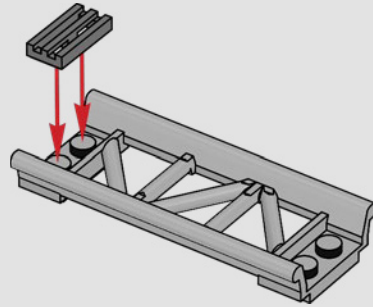

2

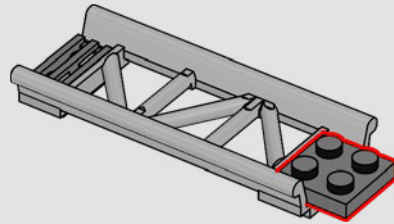

3

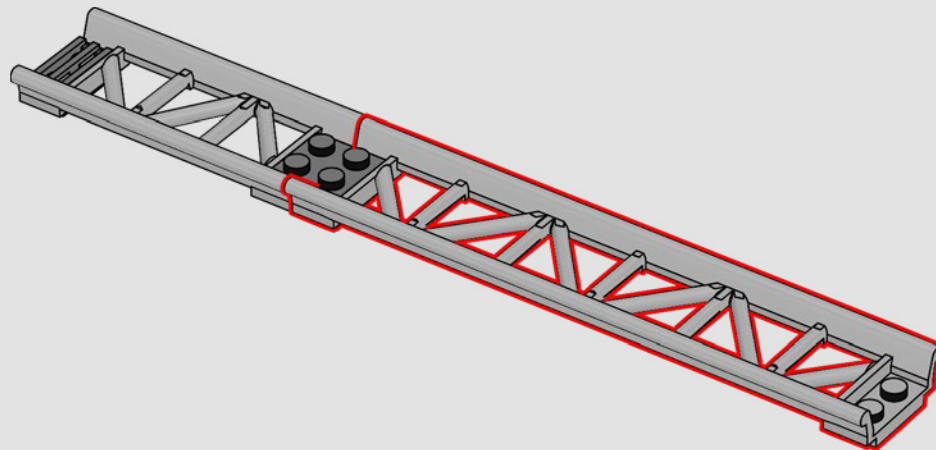

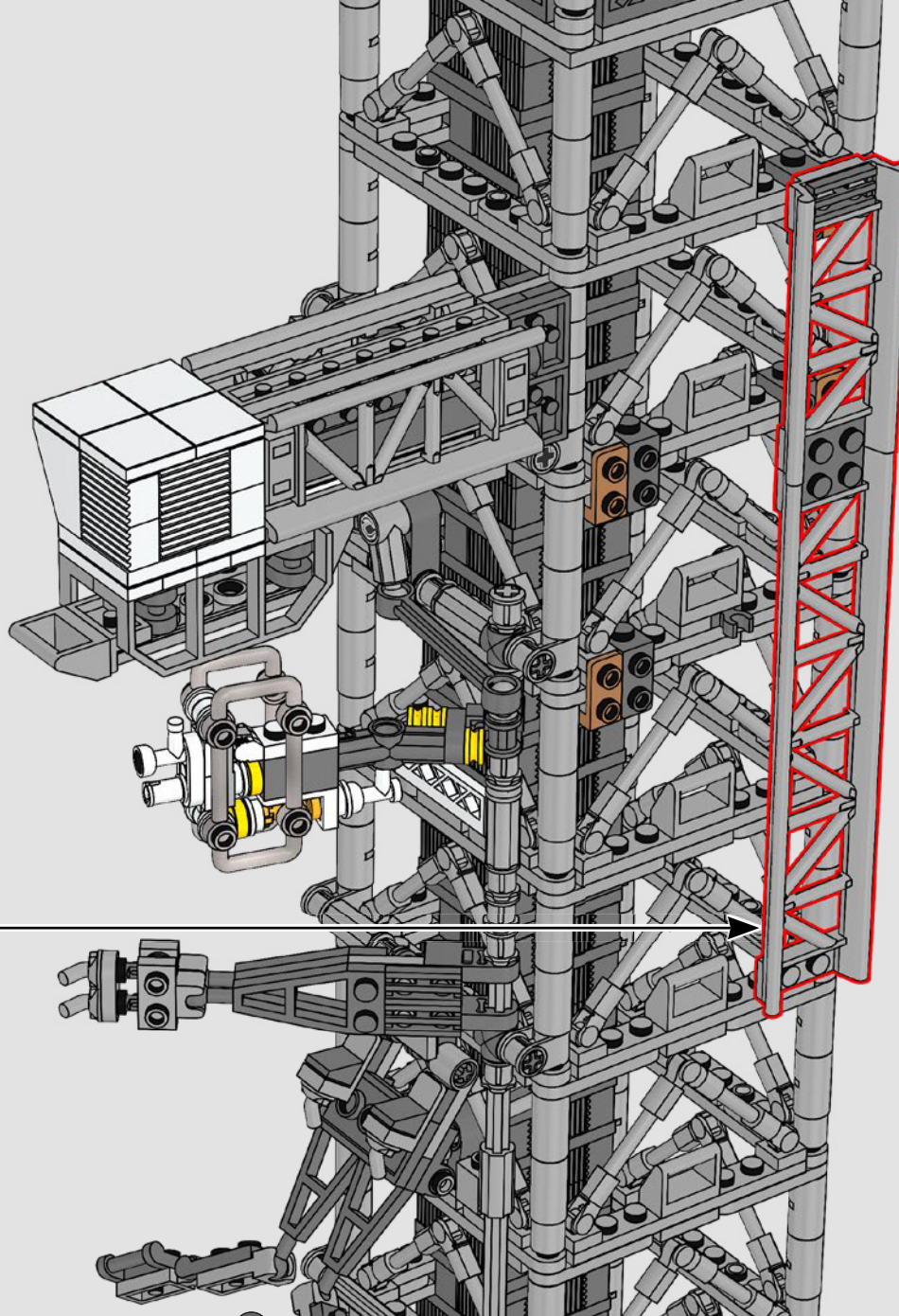

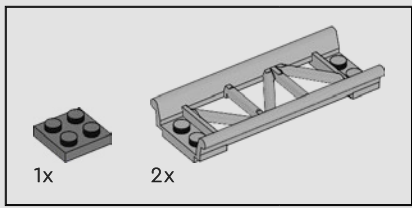

423

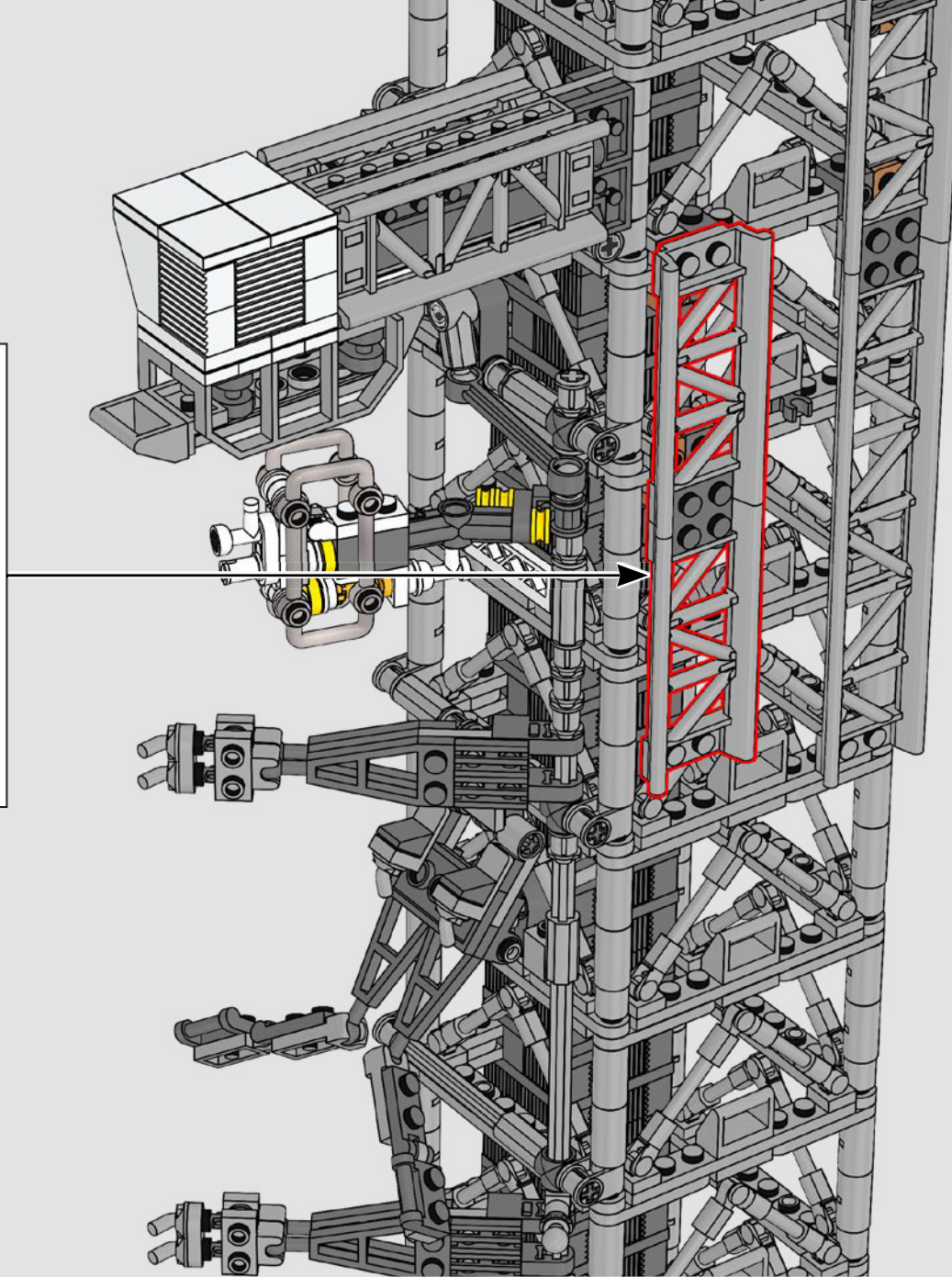
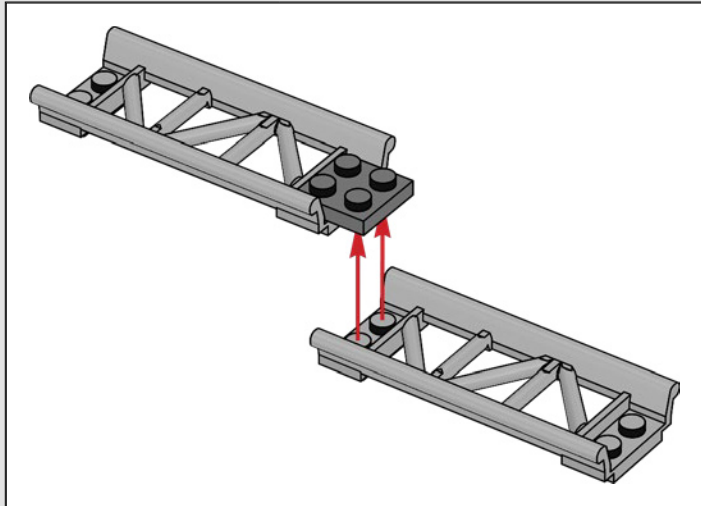

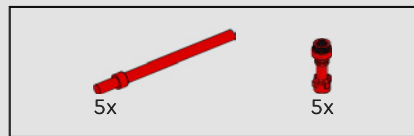

424

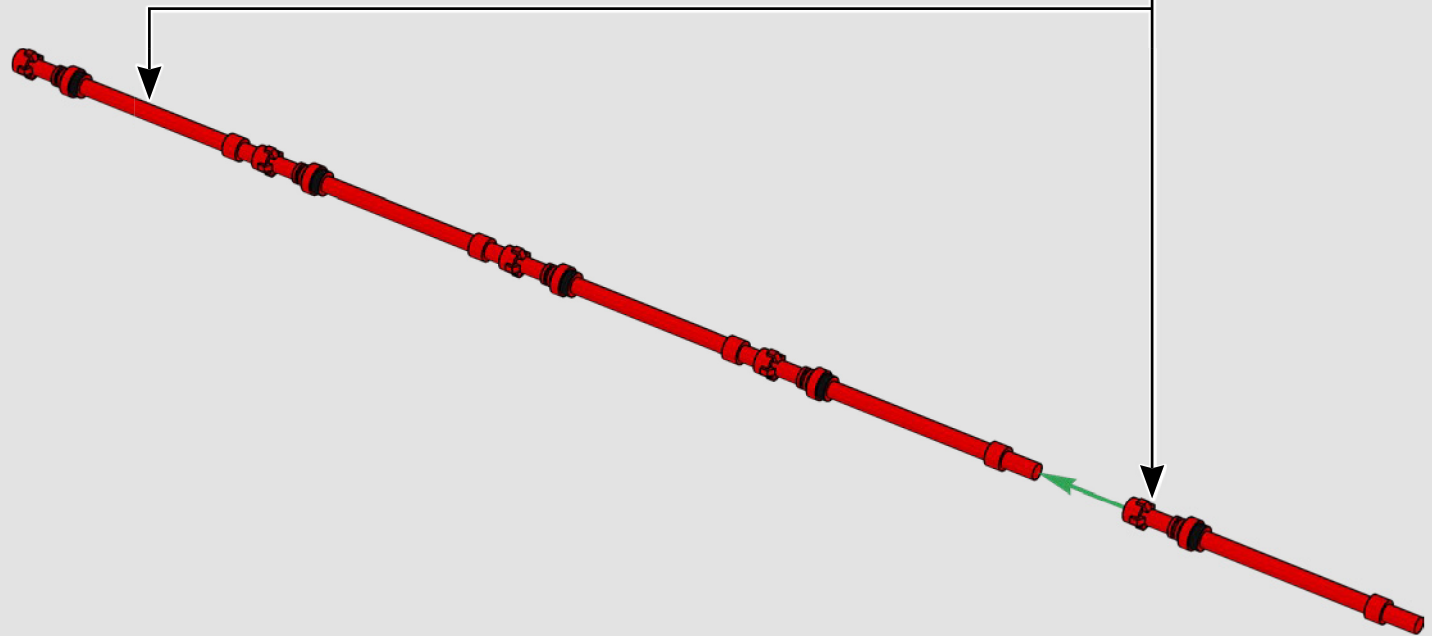
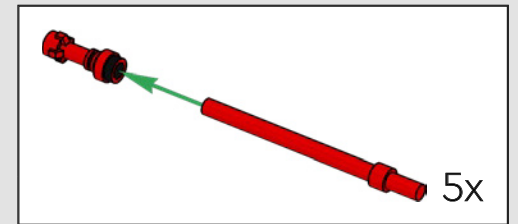

425

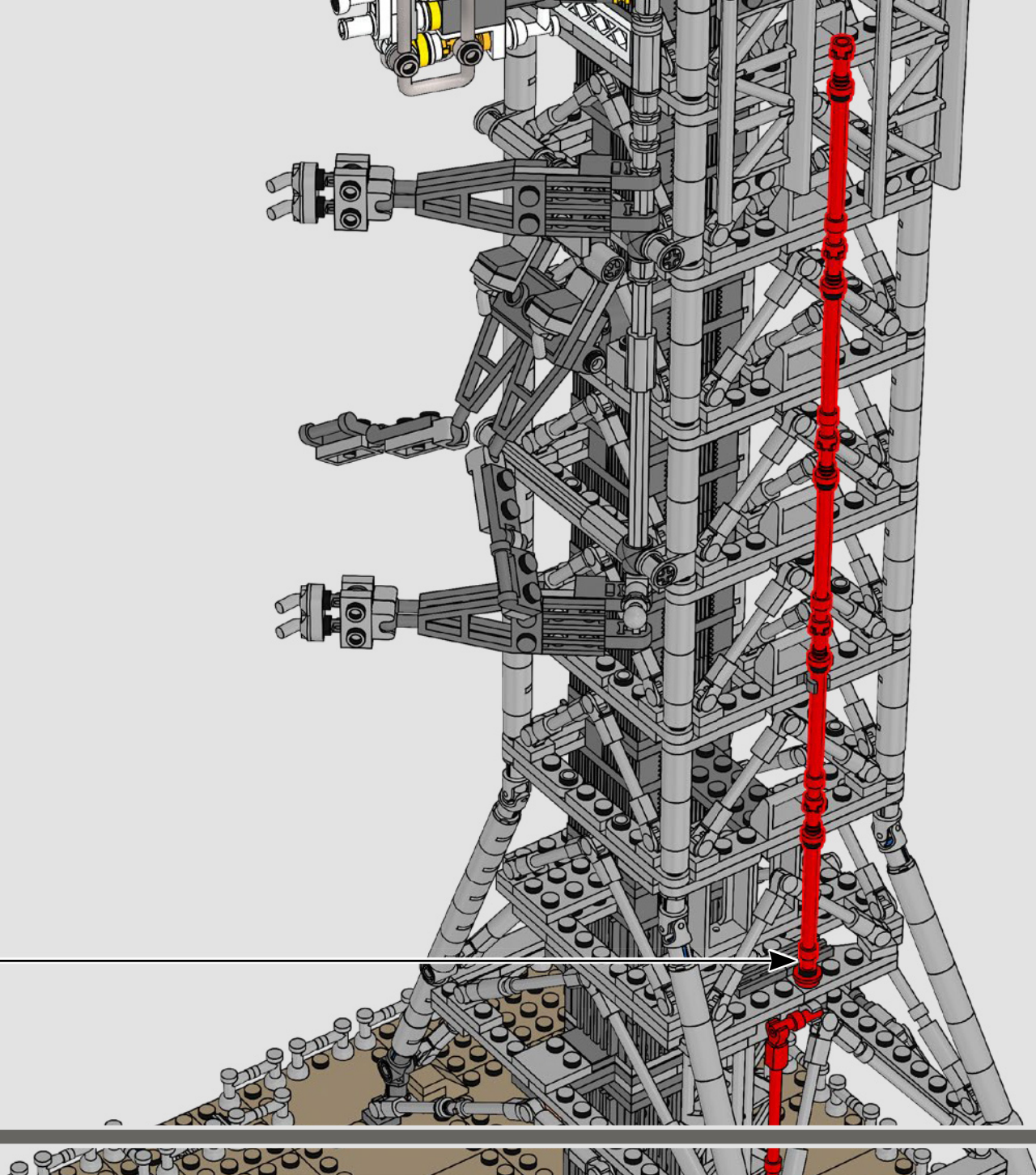

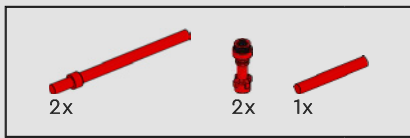

426

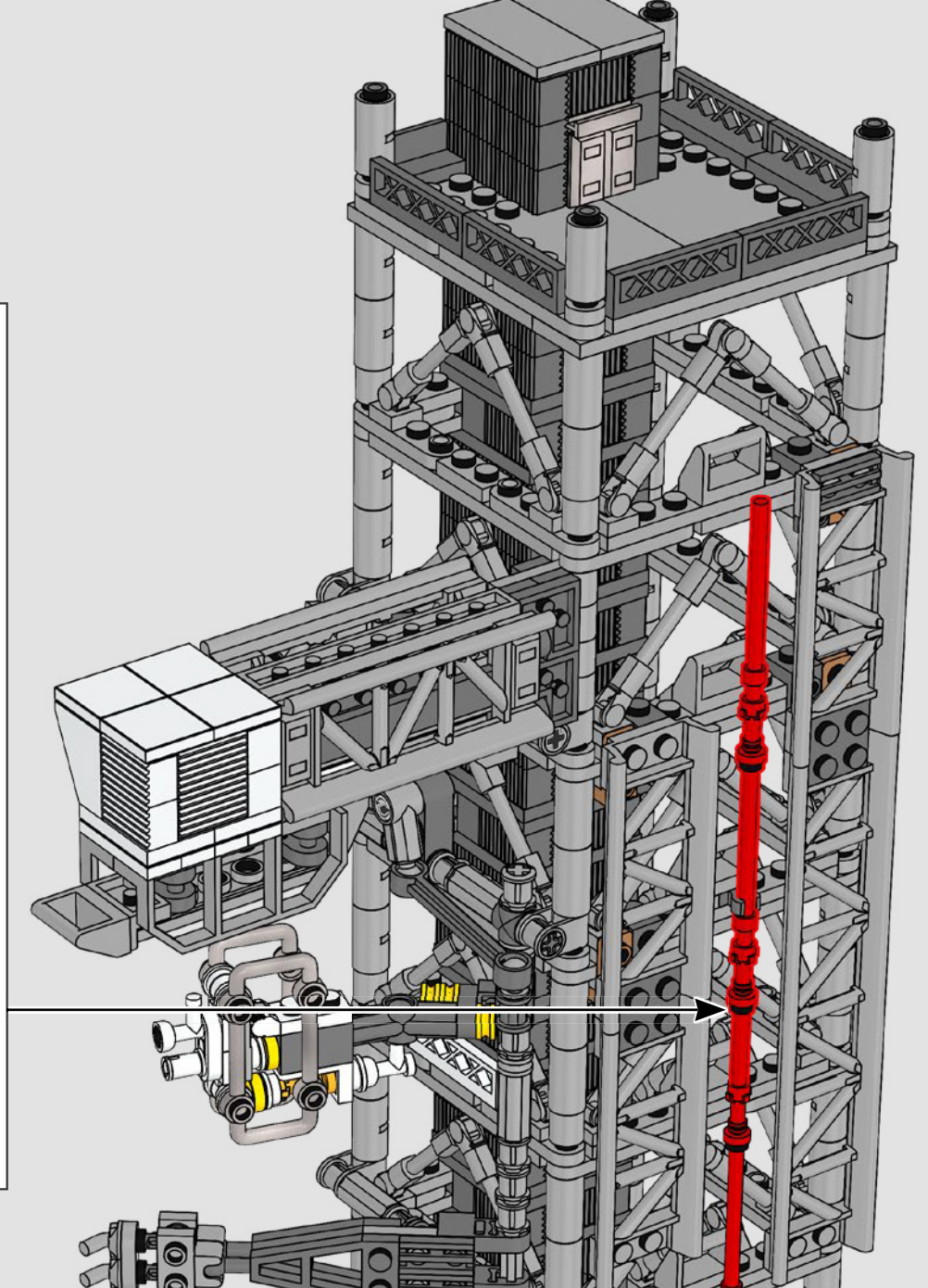
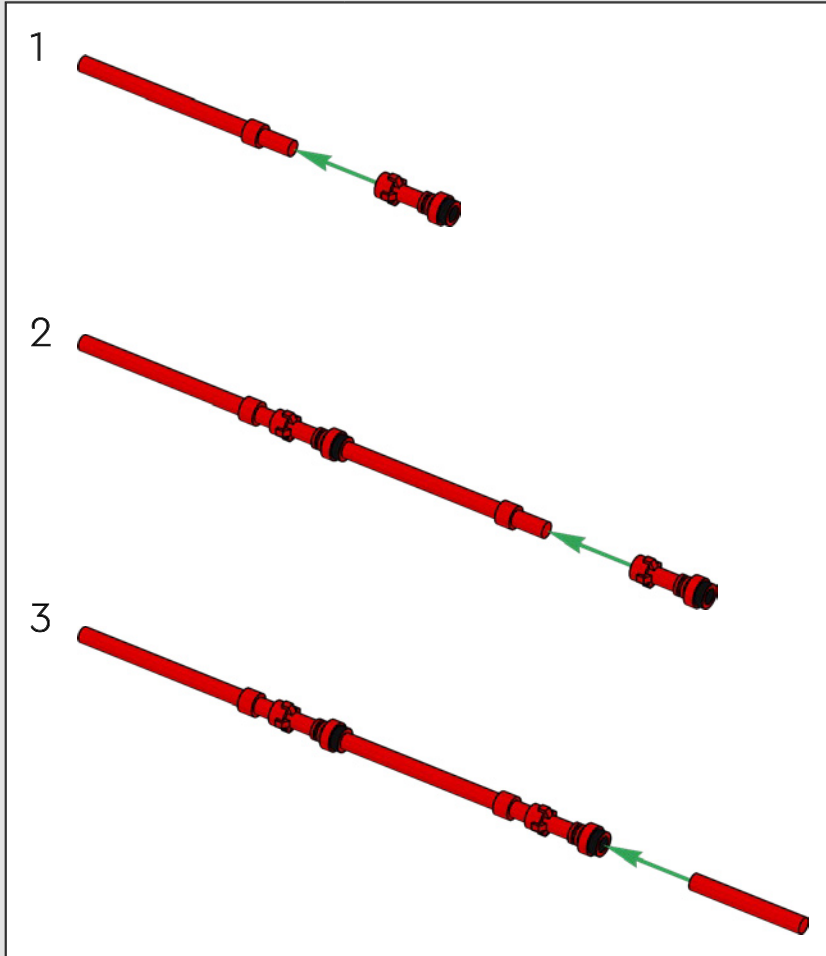

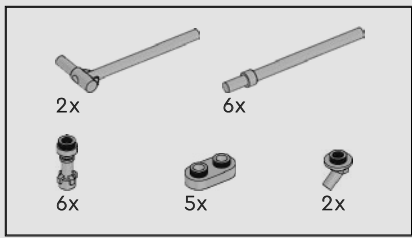

427

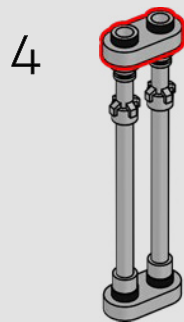
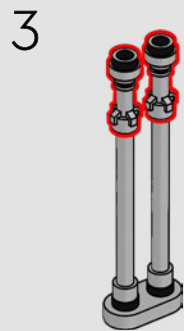
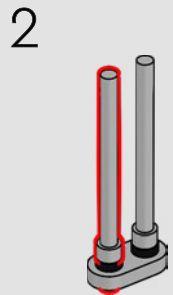
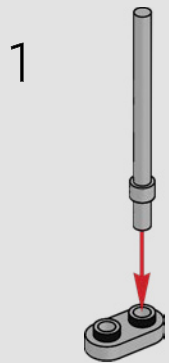

5

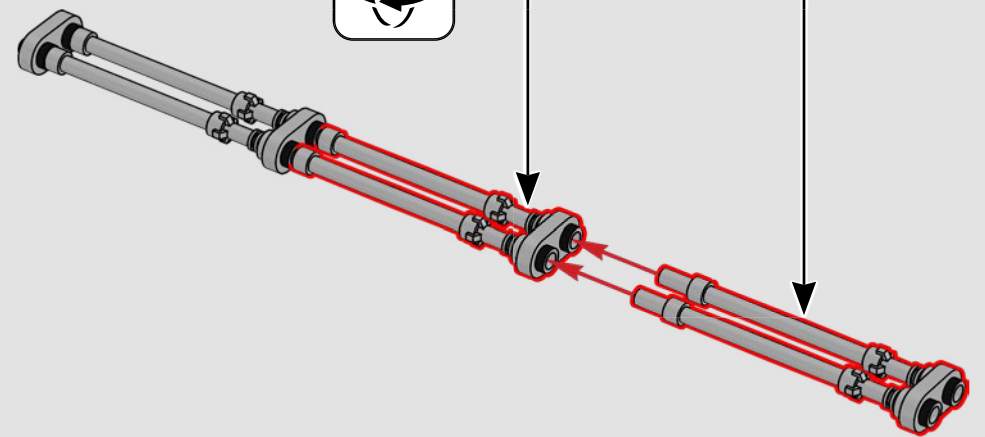
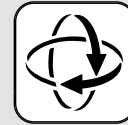
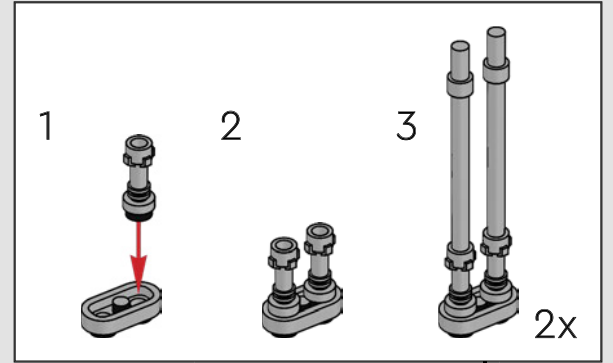



6

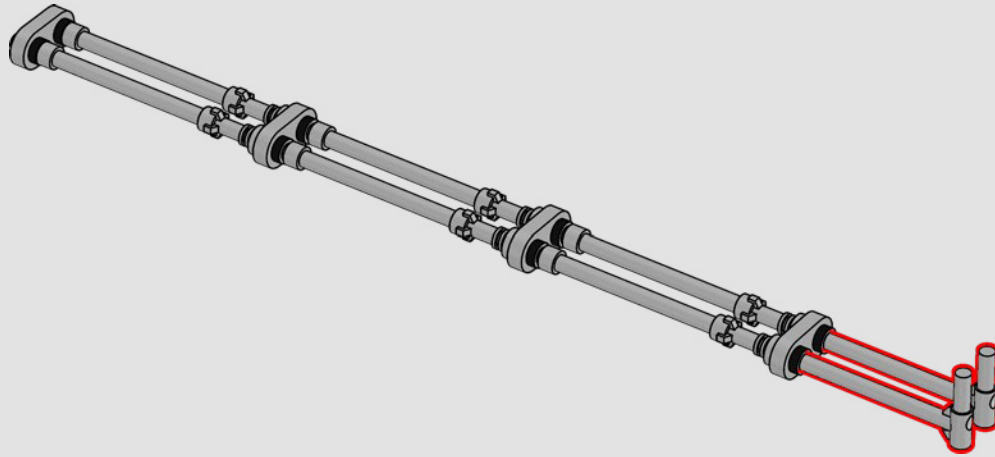

7

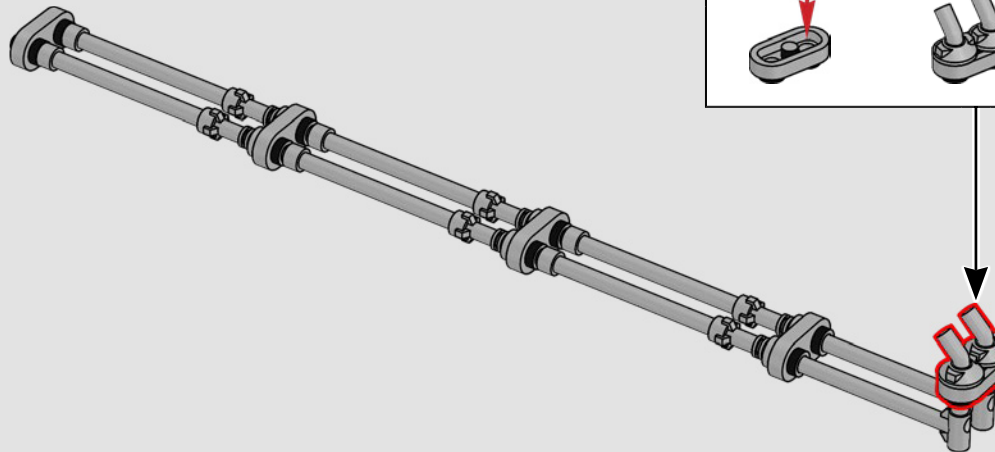

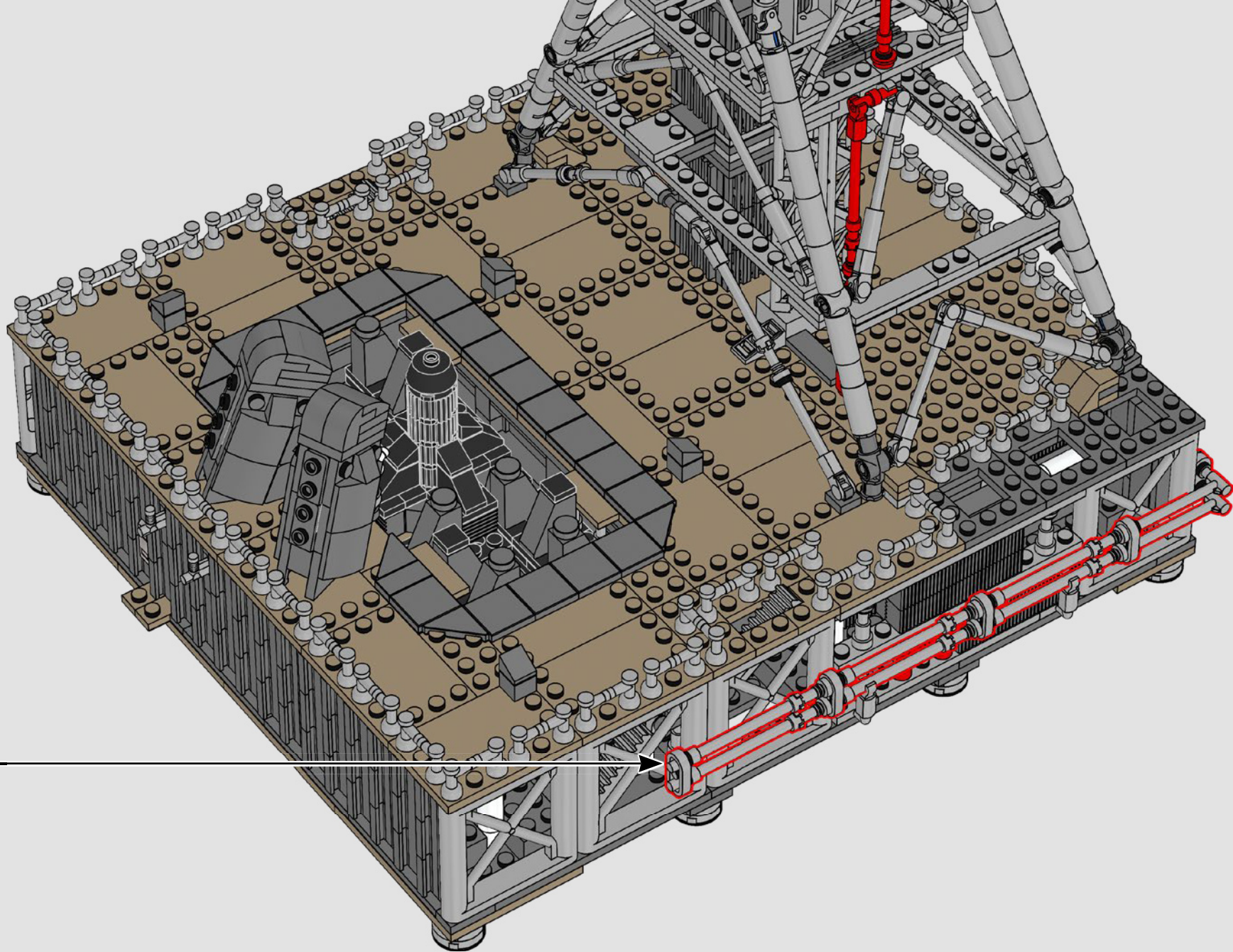

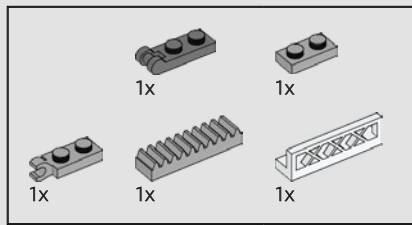

428

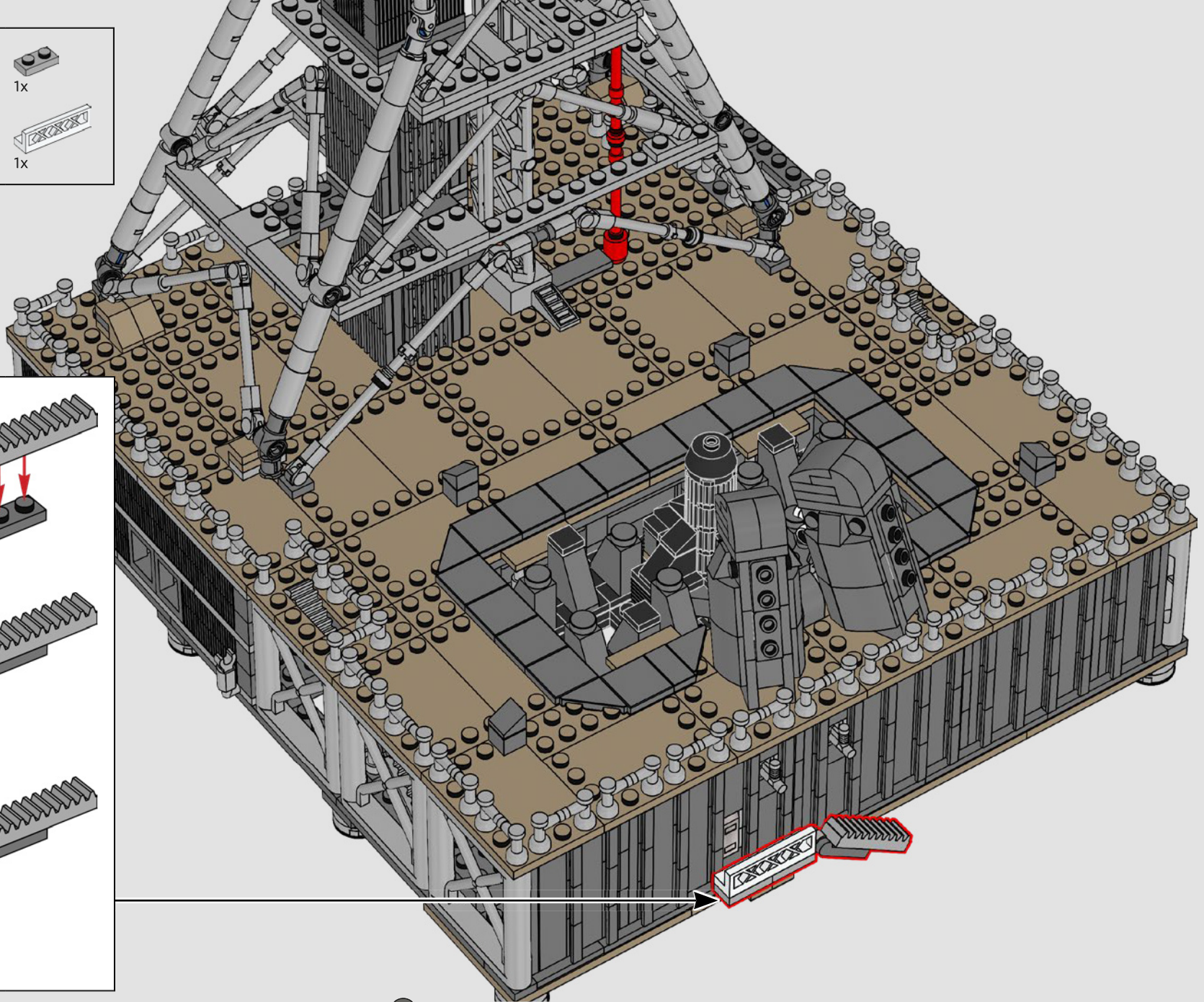
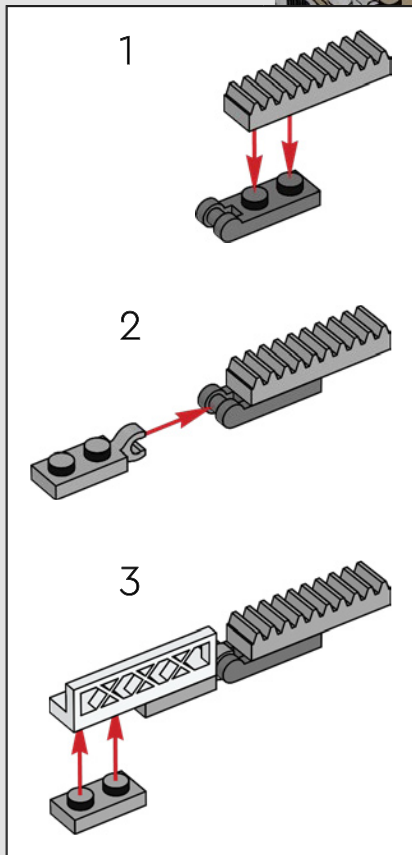

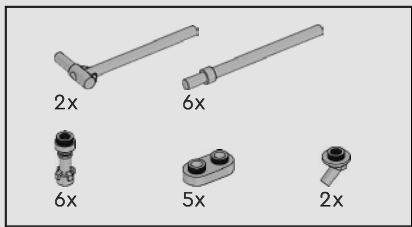

429

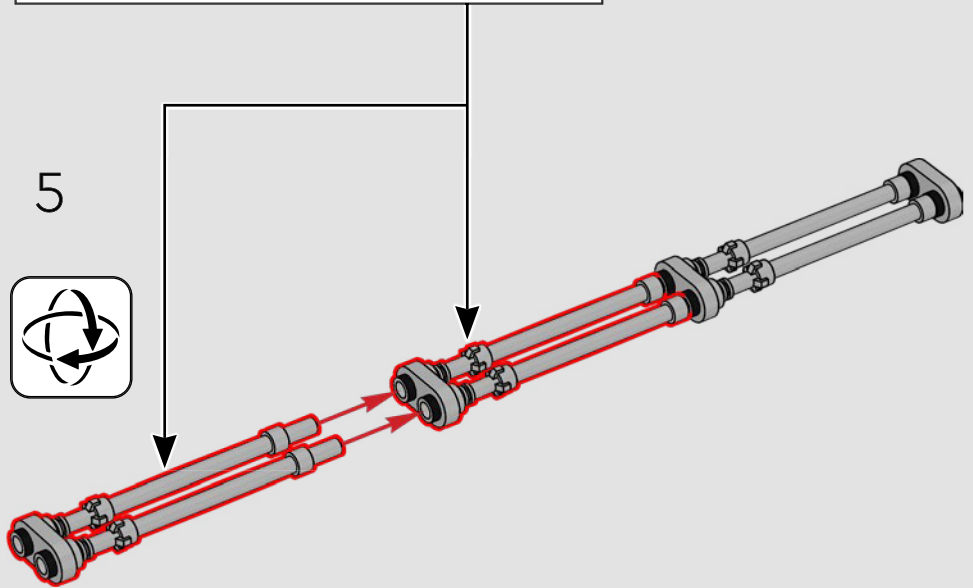
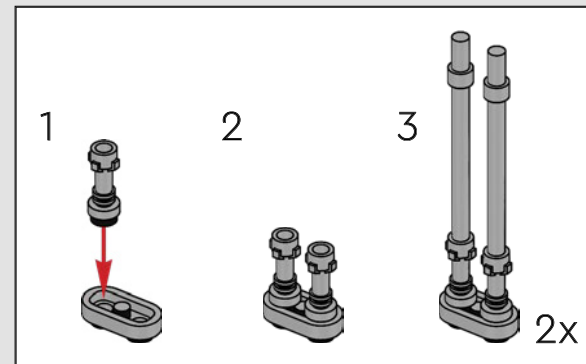
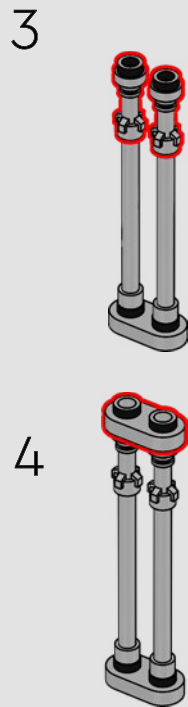
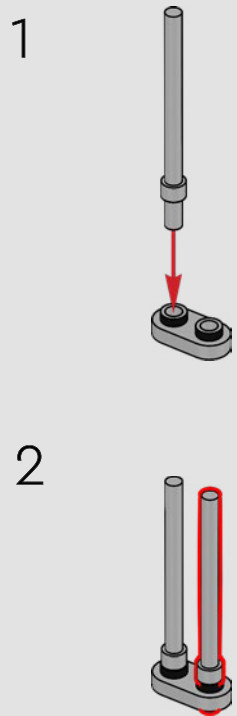

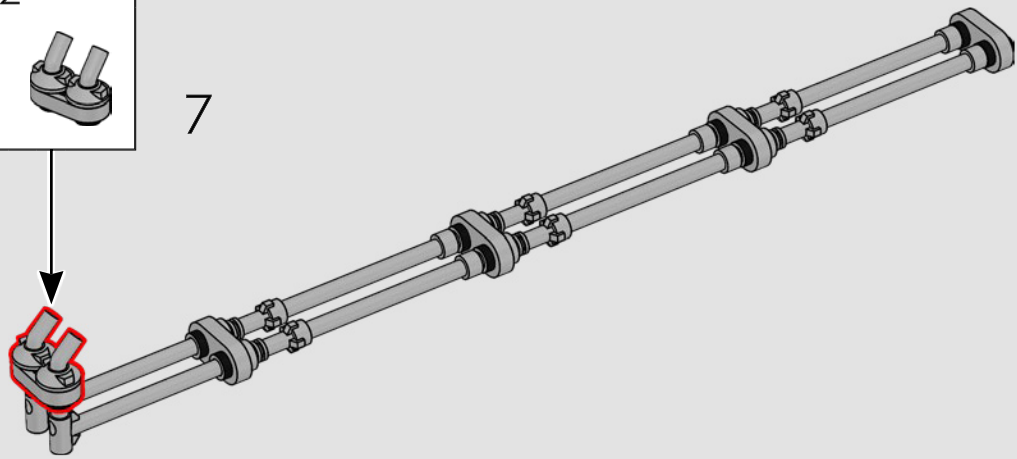
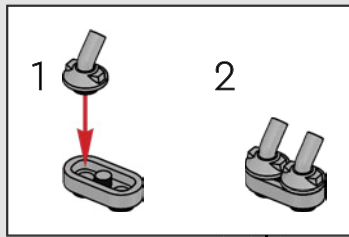
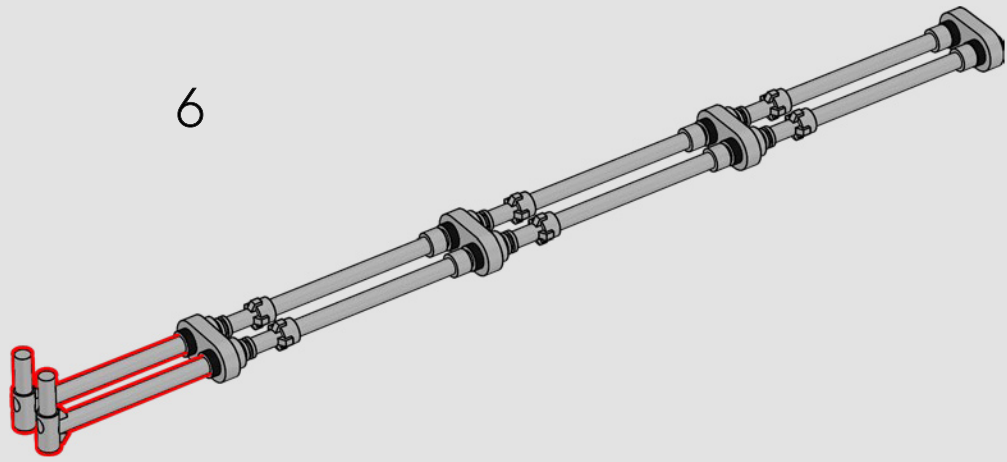

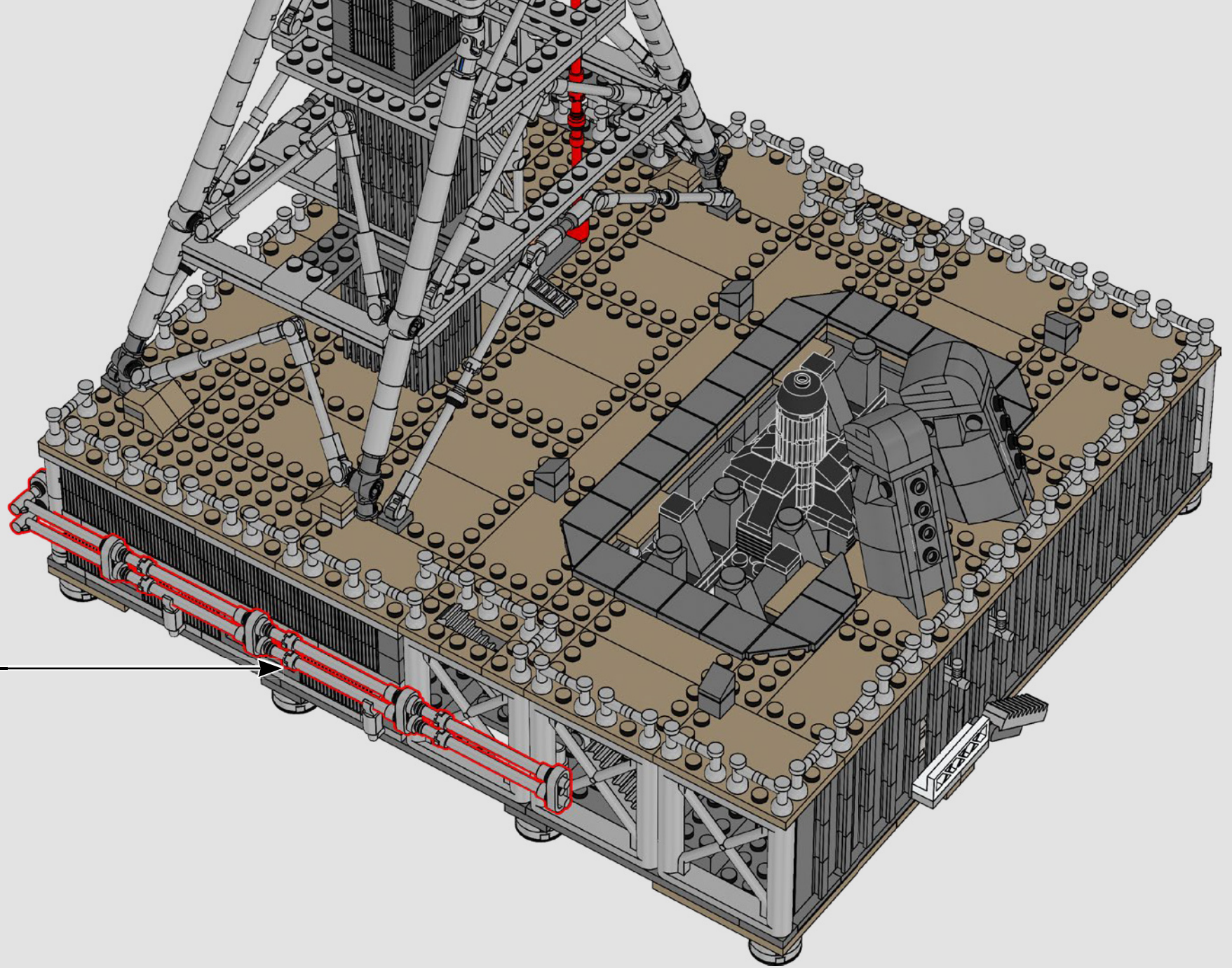



430

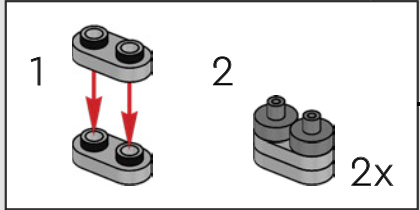
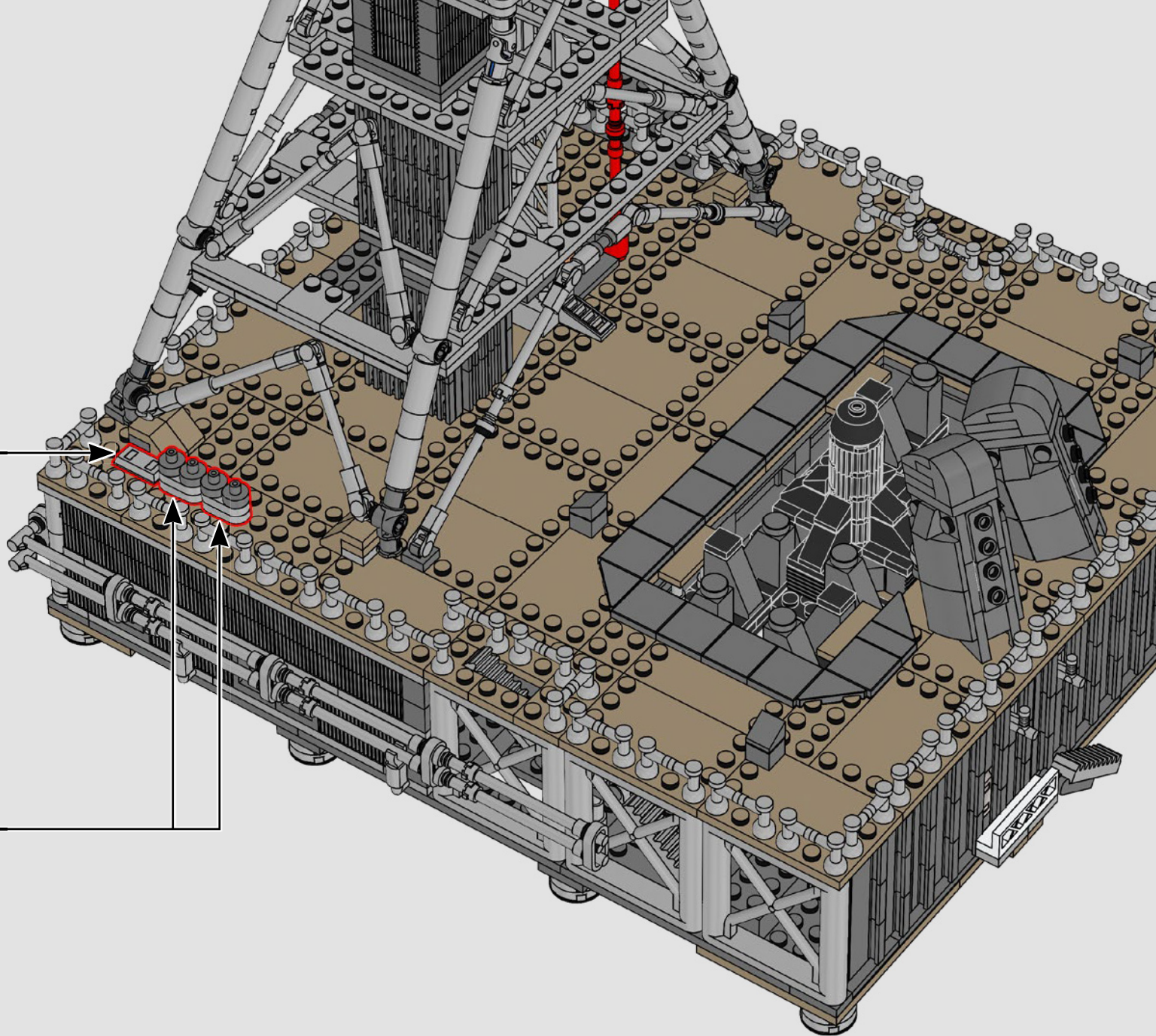
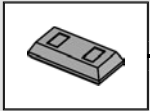

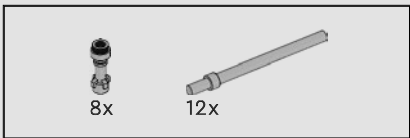

431

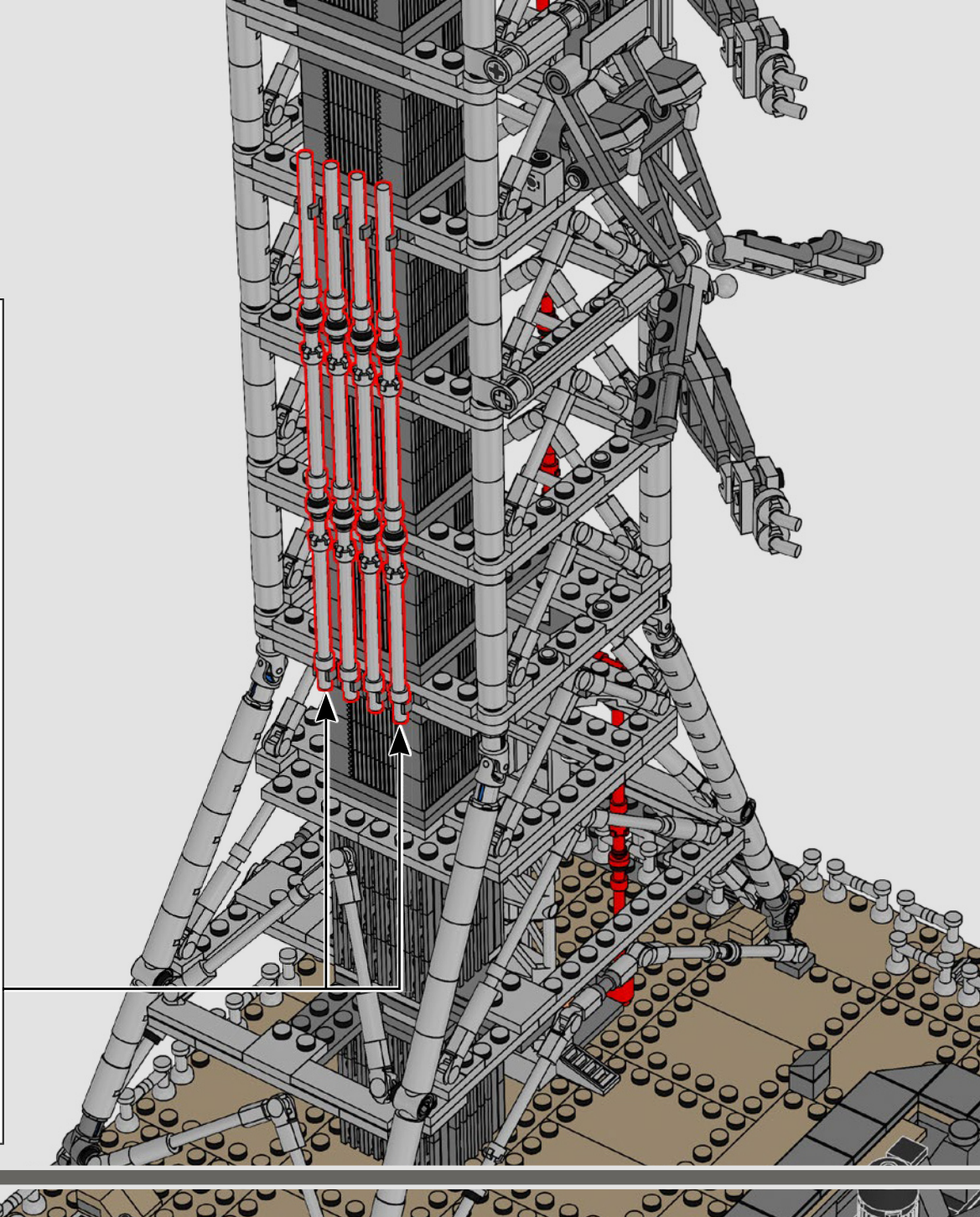
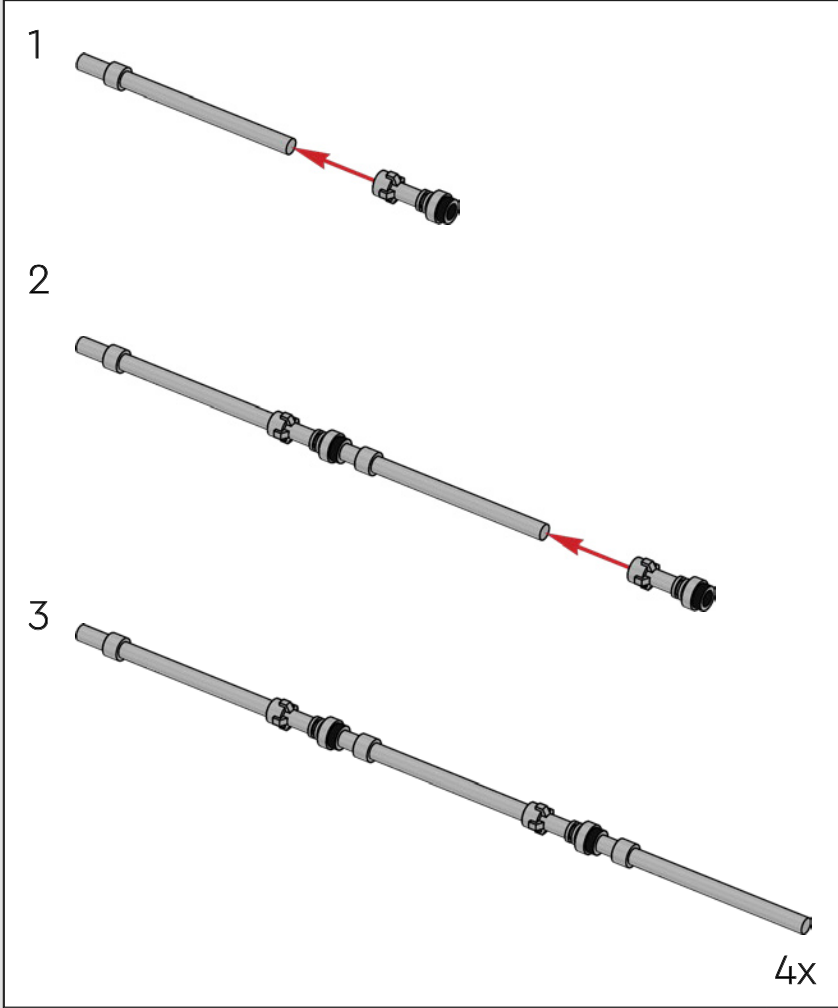



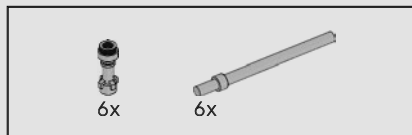

432

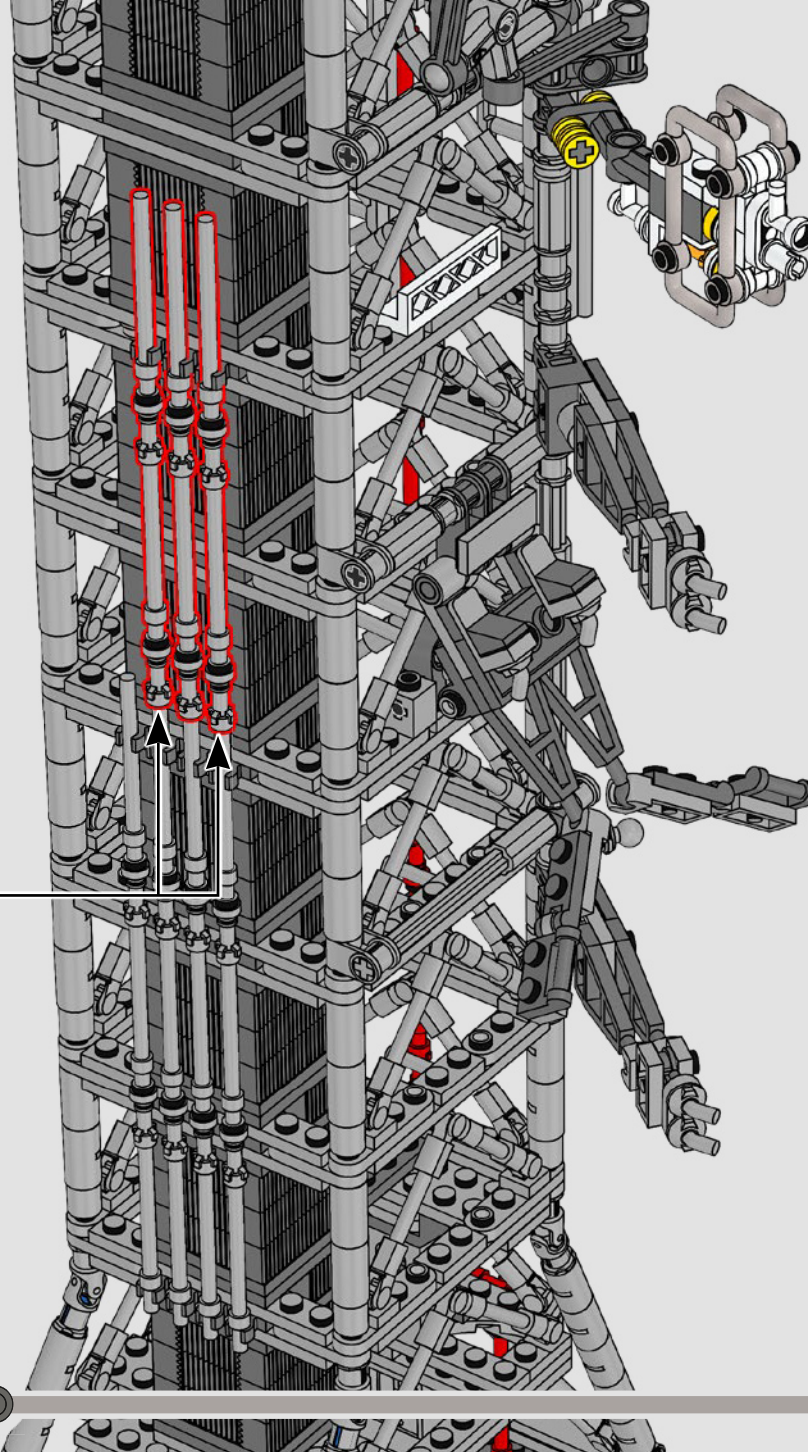
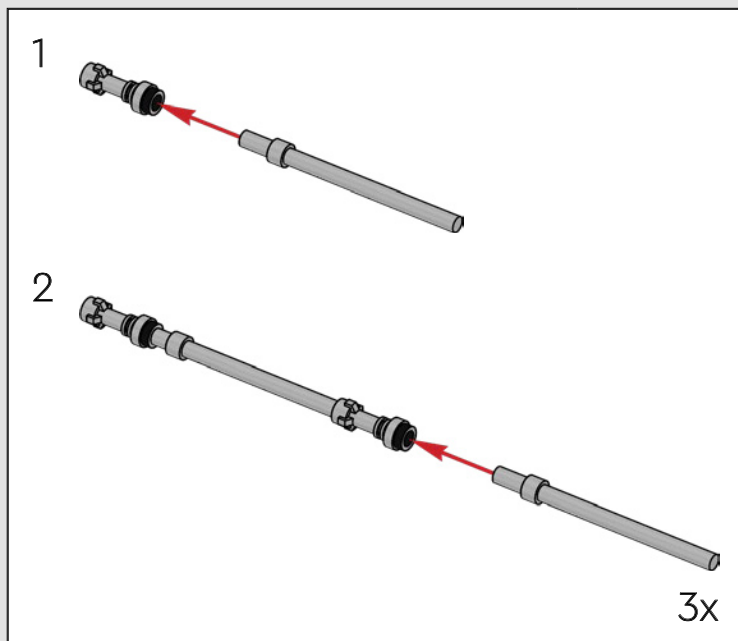

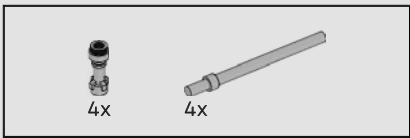

433

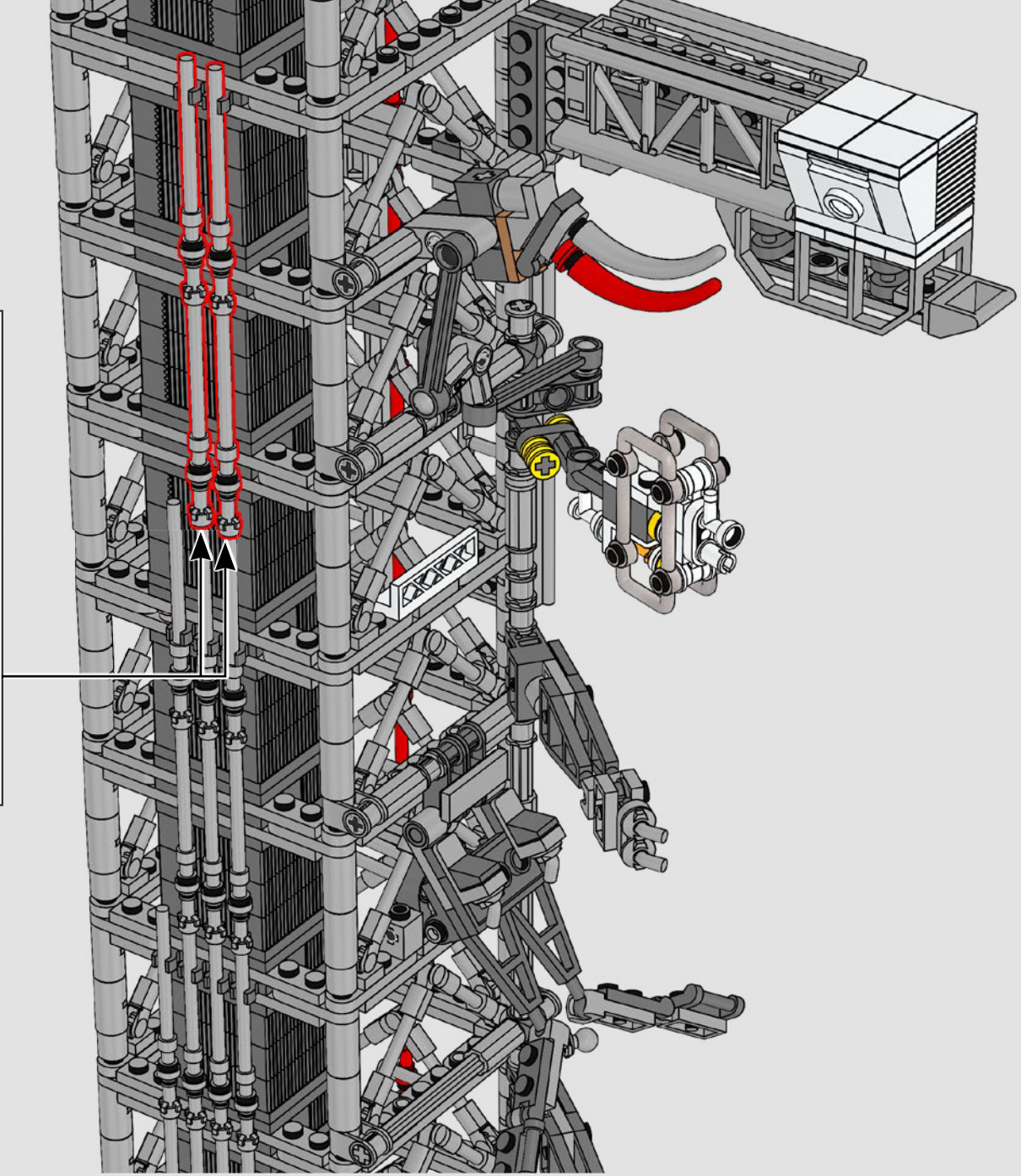
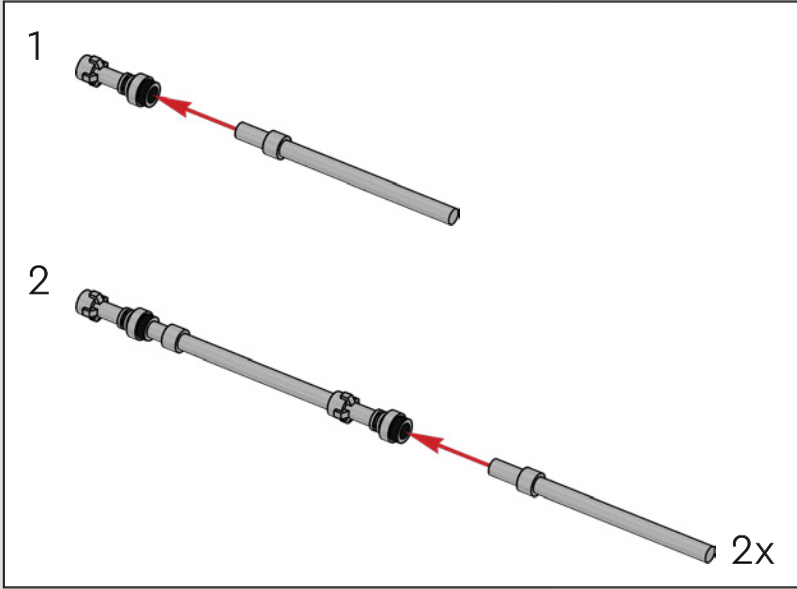

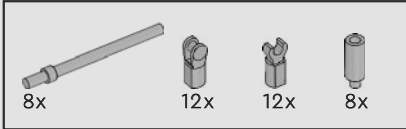
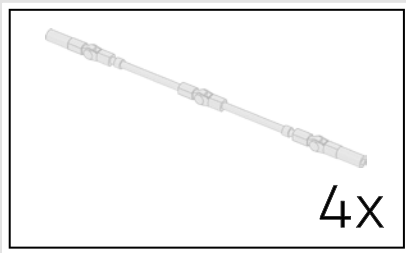

434

1

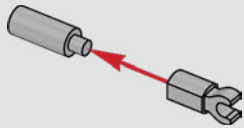

2

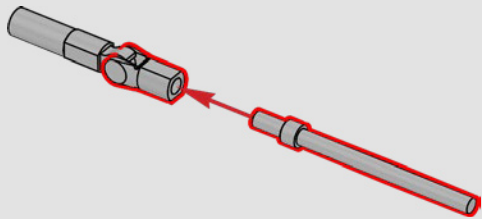

3

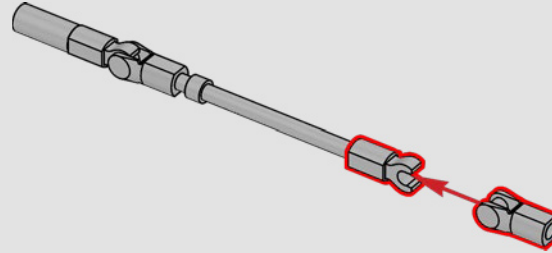

4

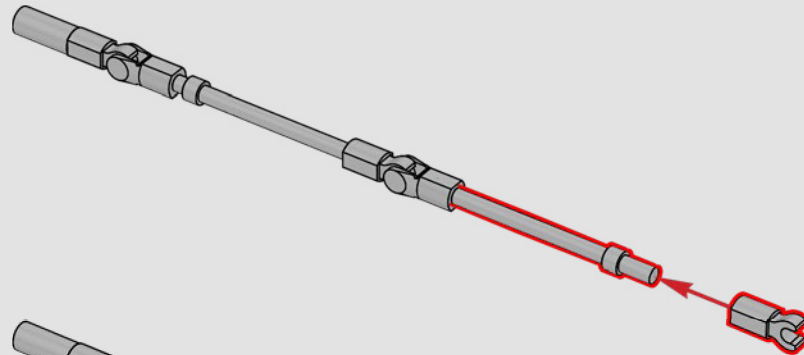

5

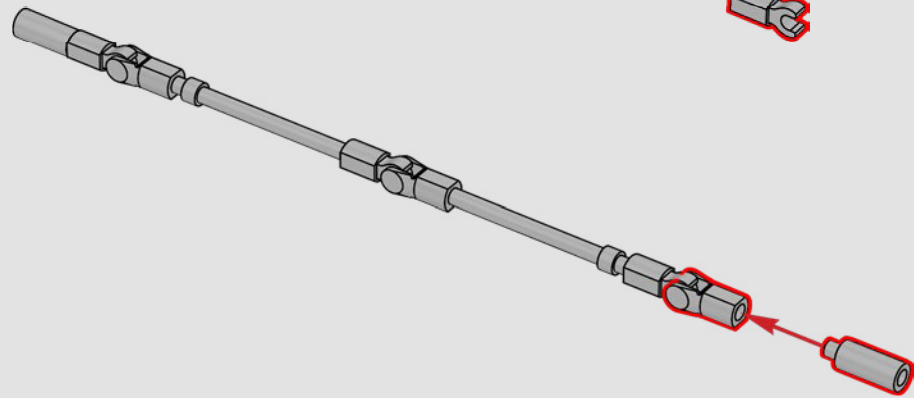

4x

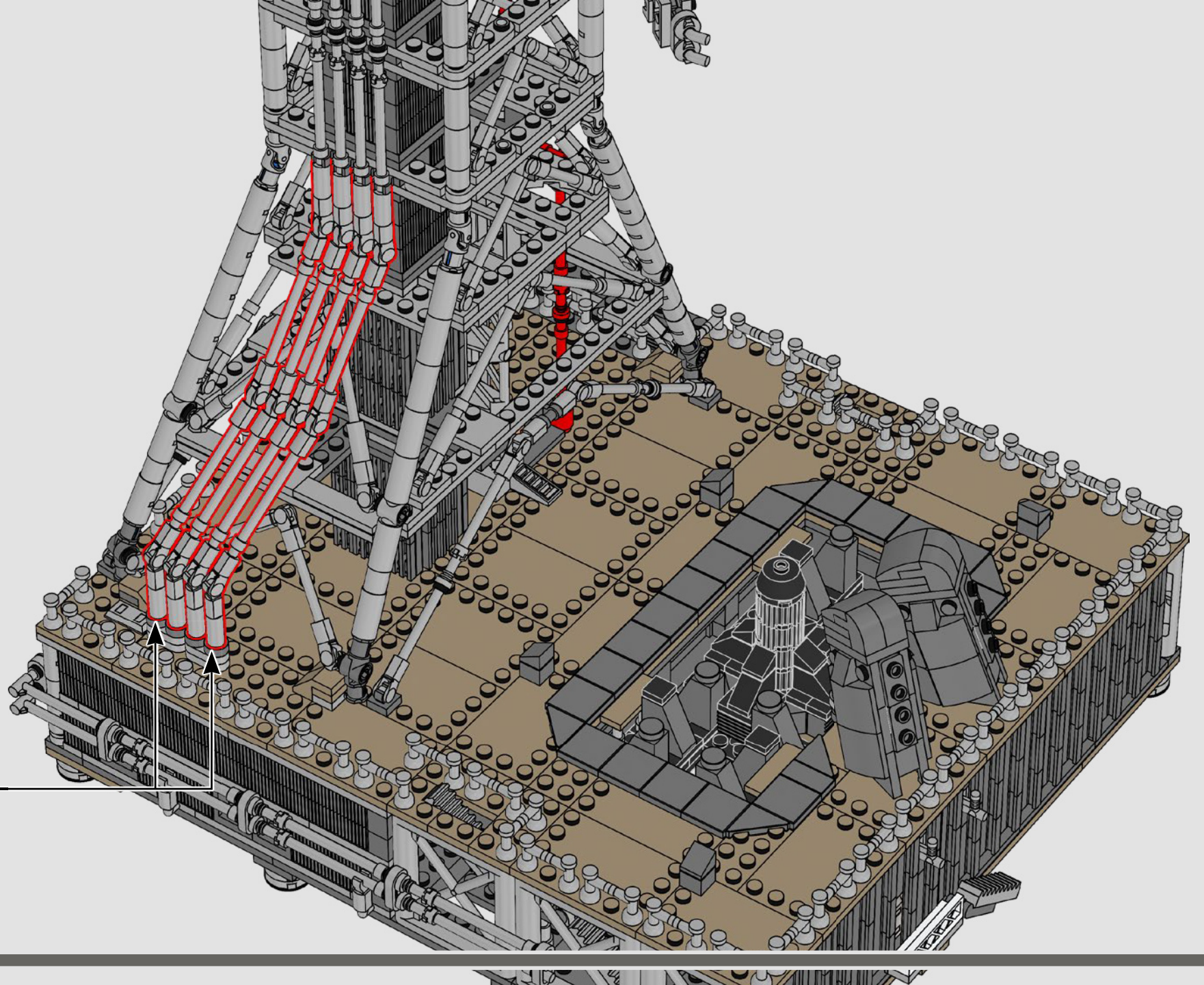

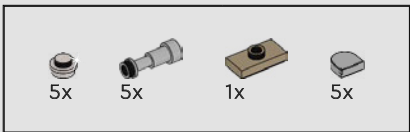

435

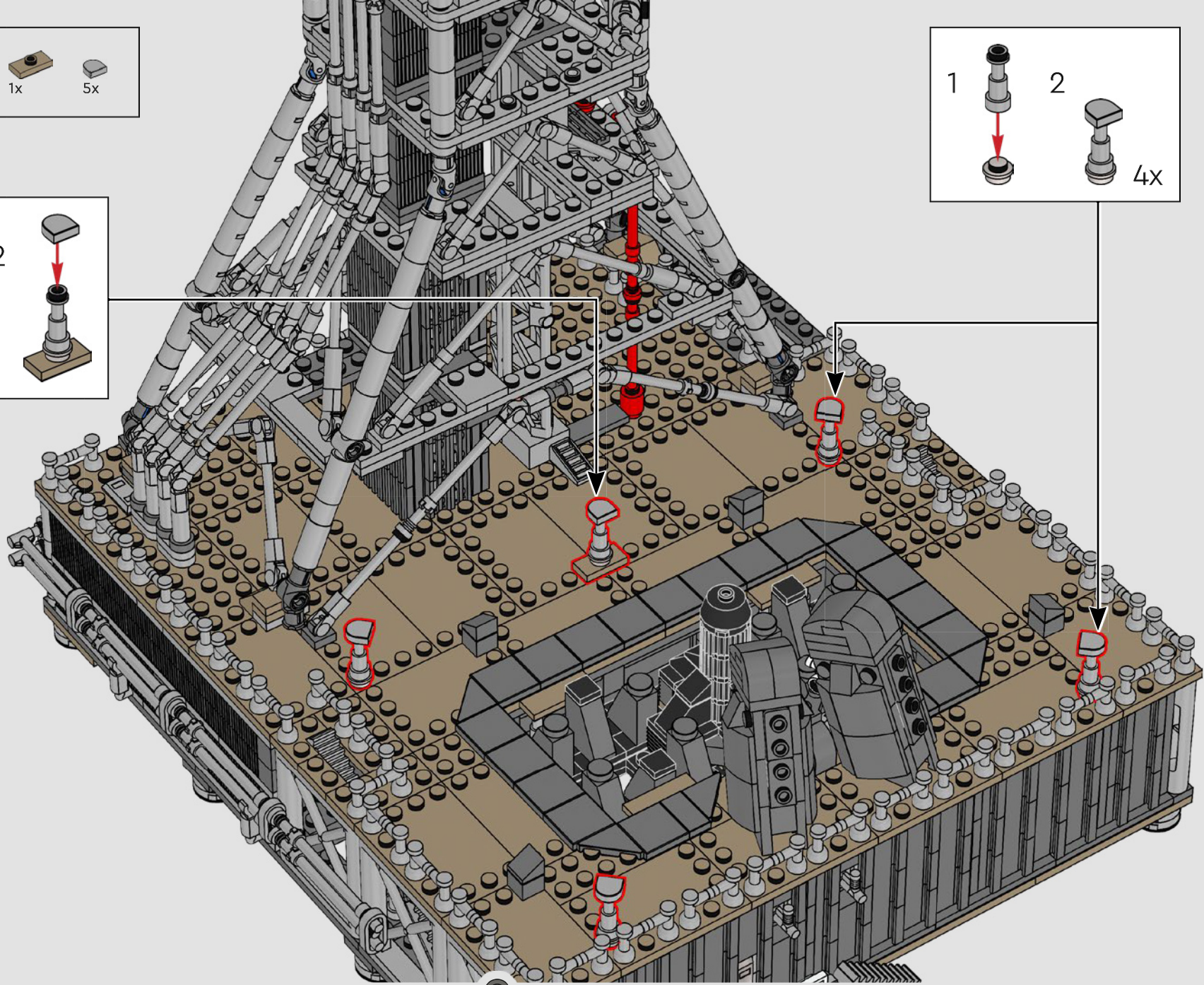
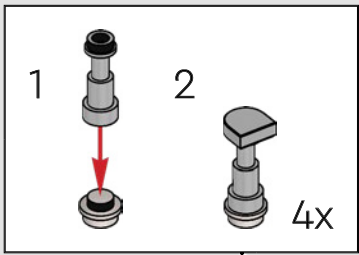
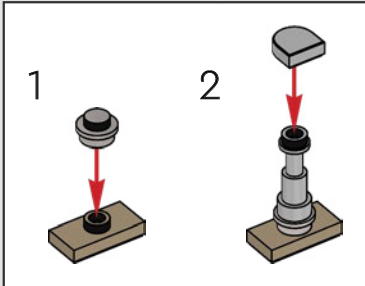

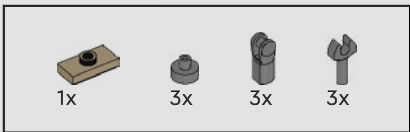

436

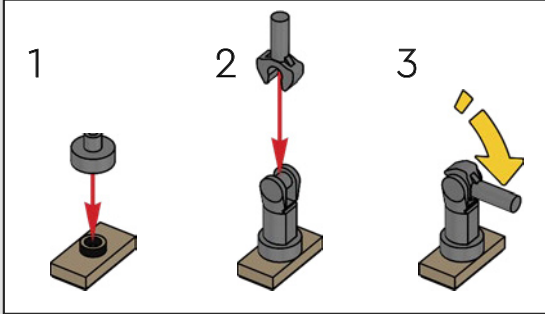
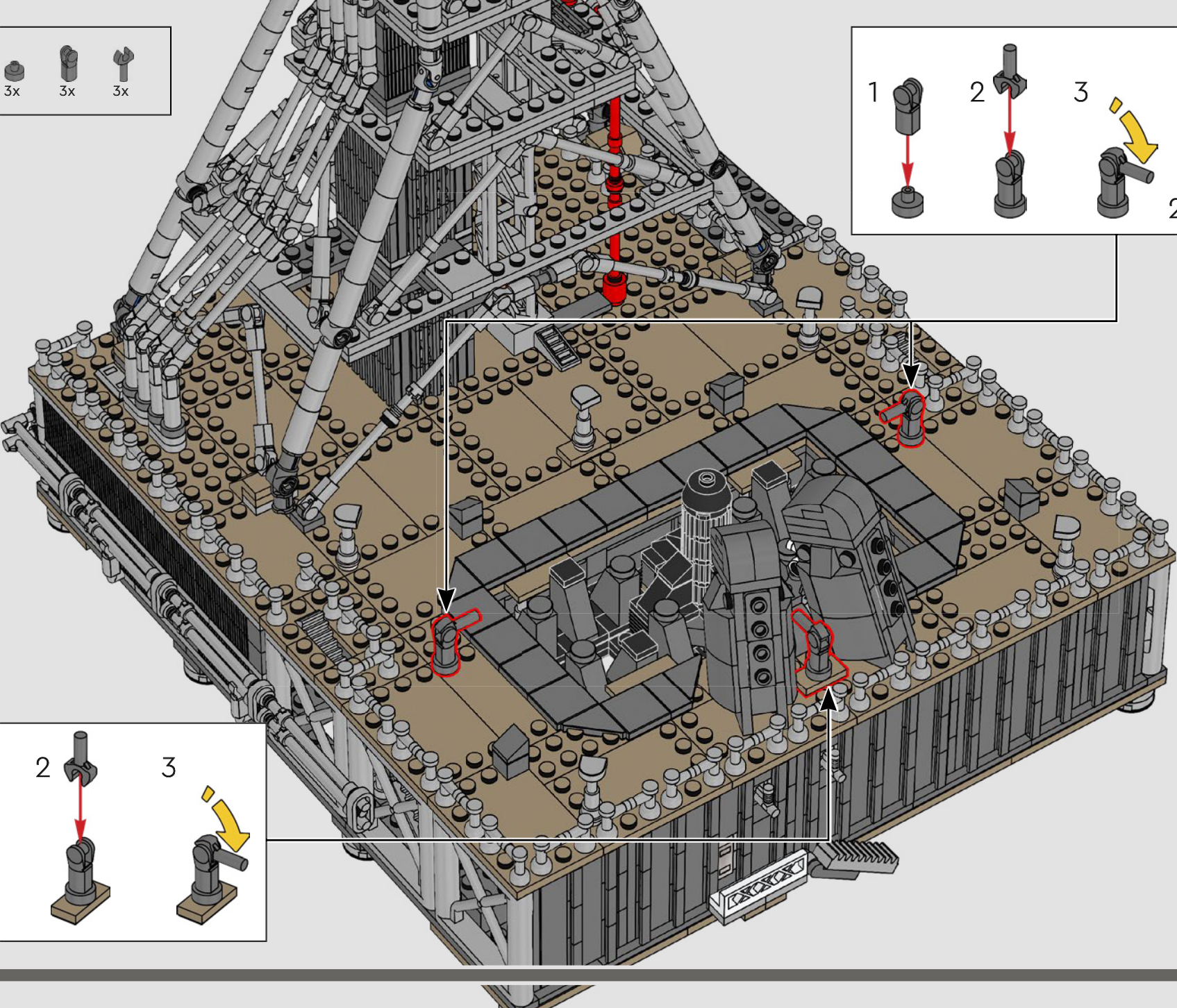
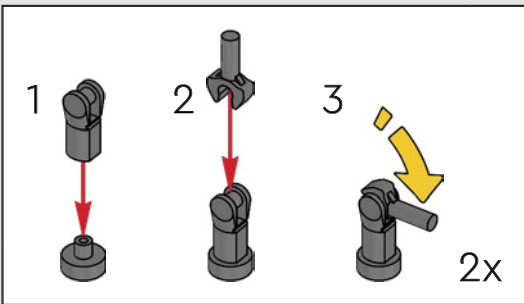

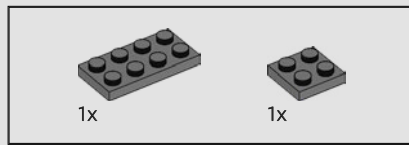

437

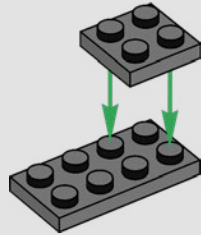

438

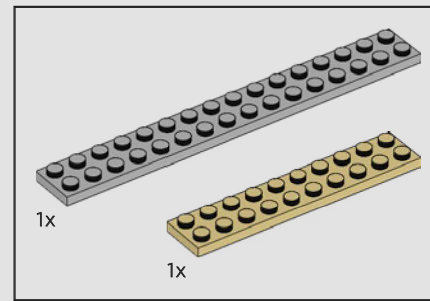
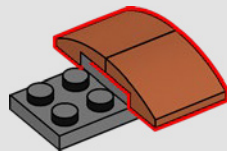

439

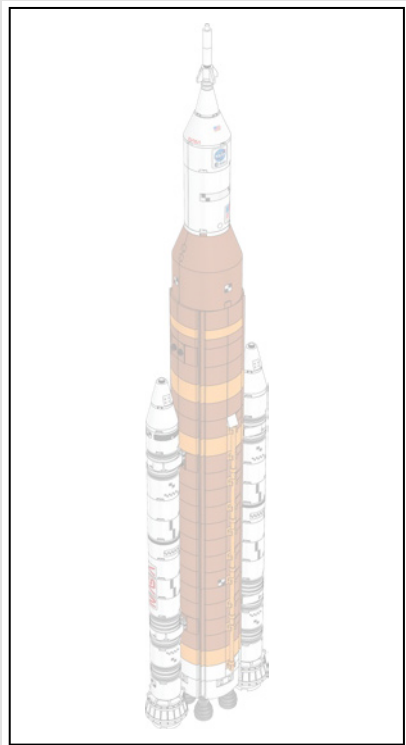
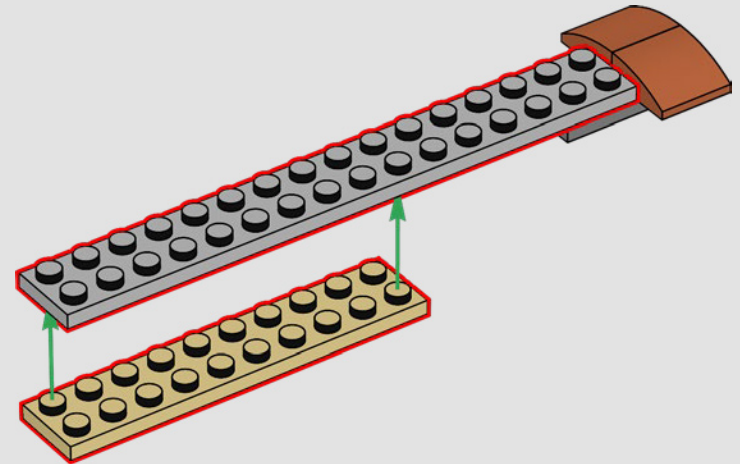

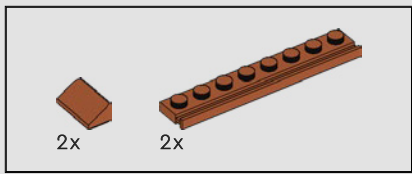

440

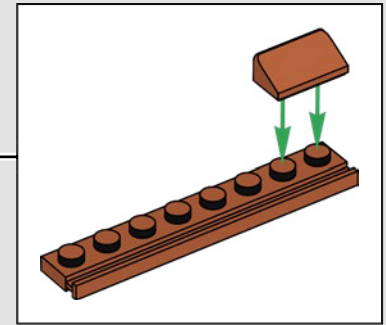
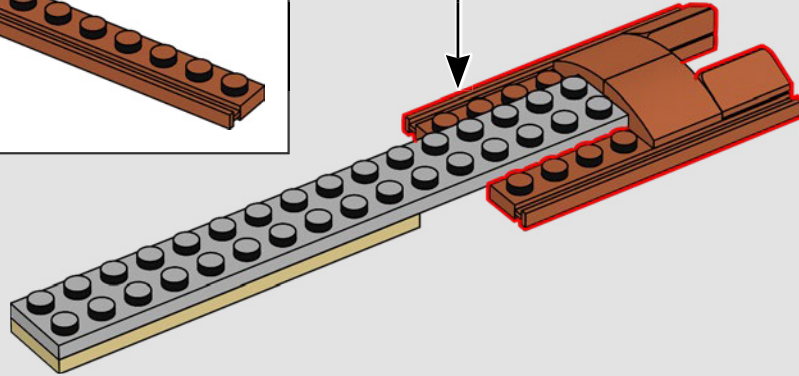
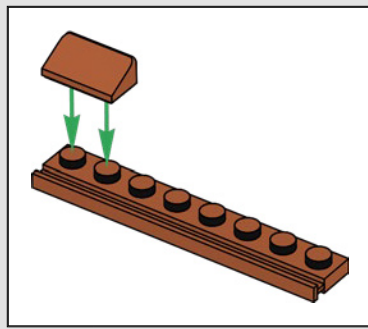

441

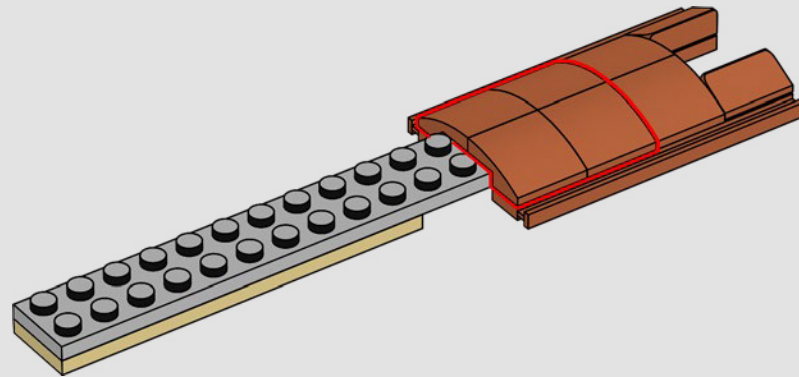



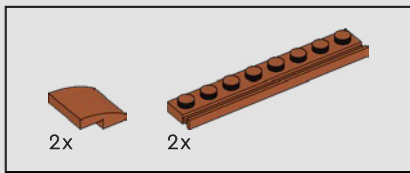

442

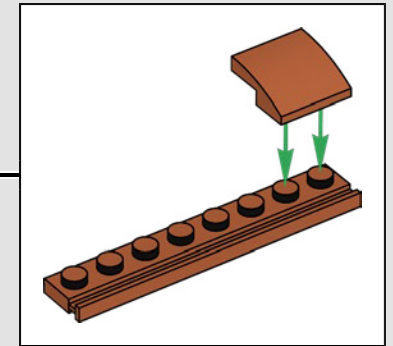
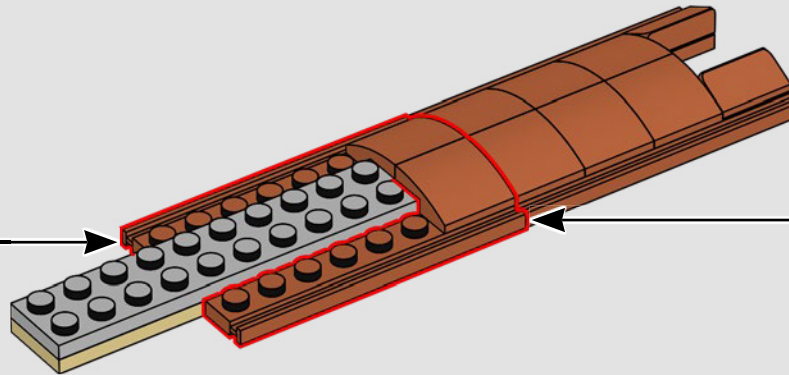
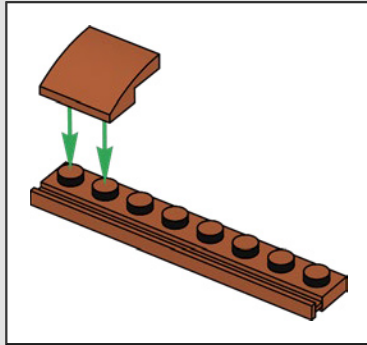

443

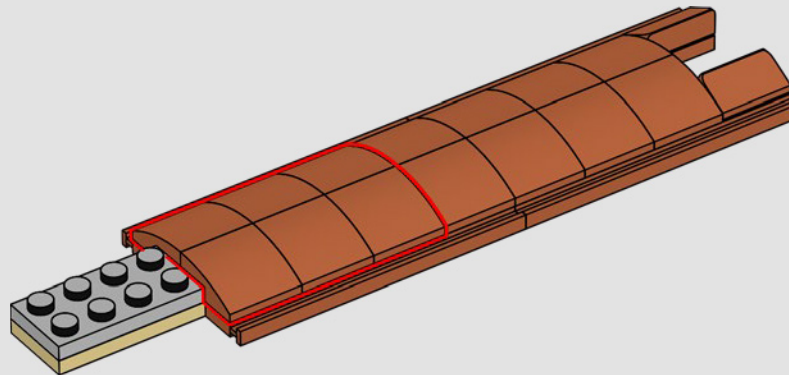

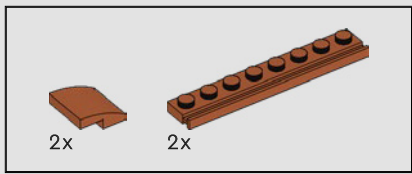

444

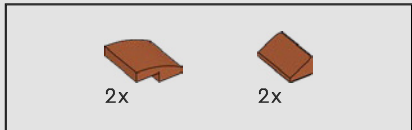
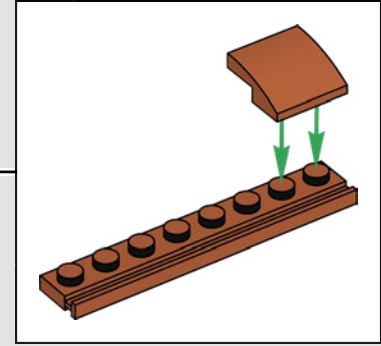
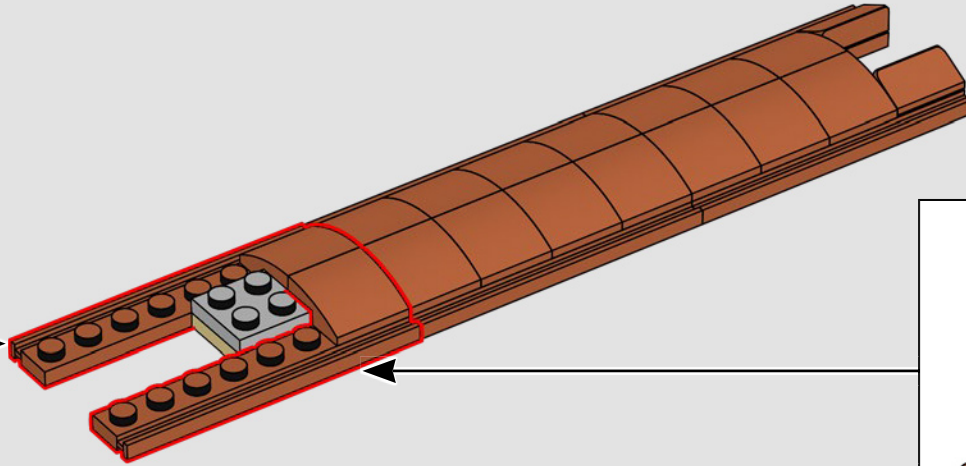
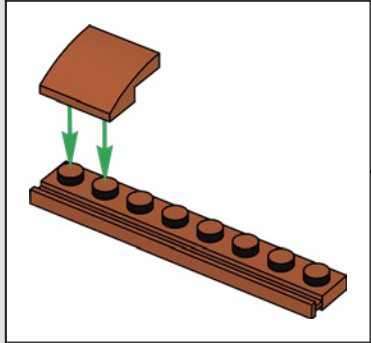

445

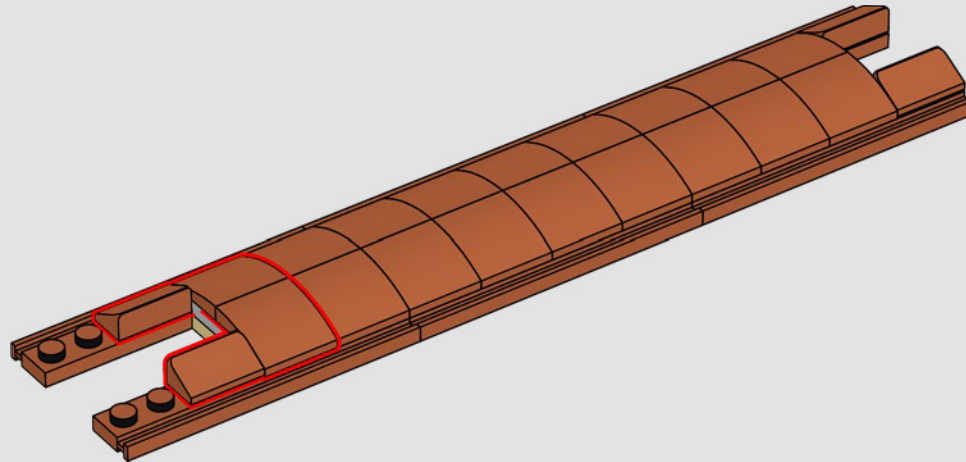

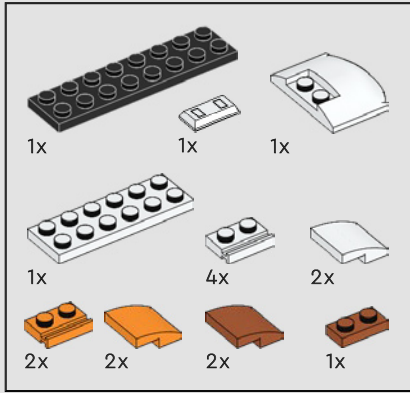
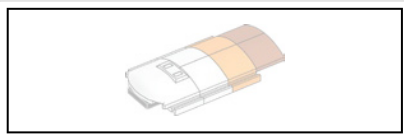

446

1

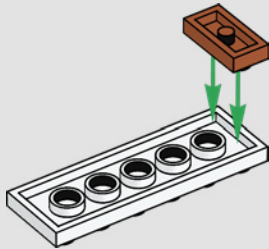

2

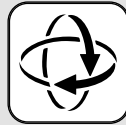
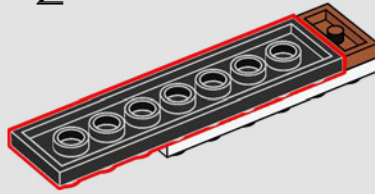

3

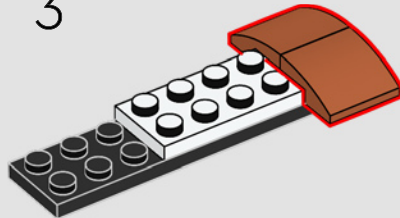

4

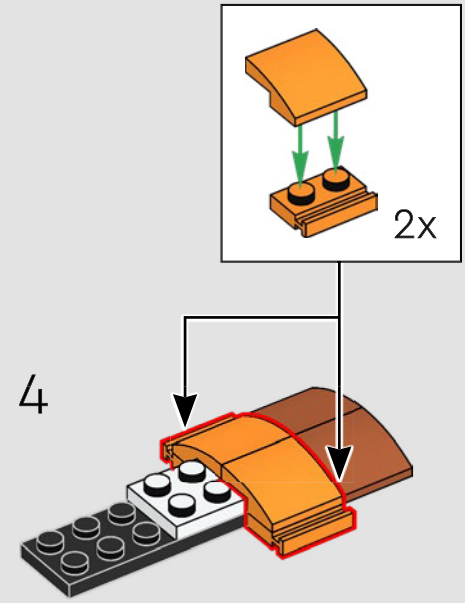

5

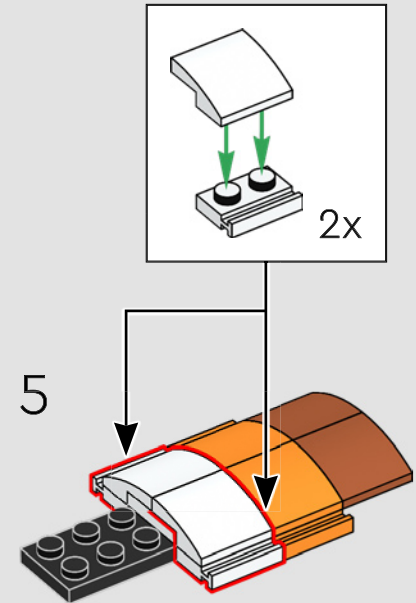

6

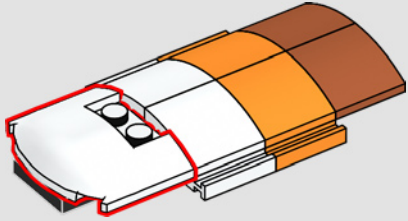

7

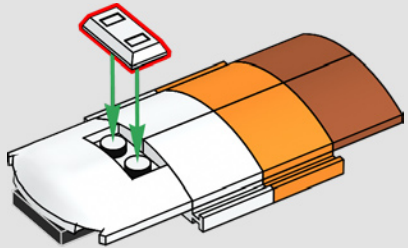

8

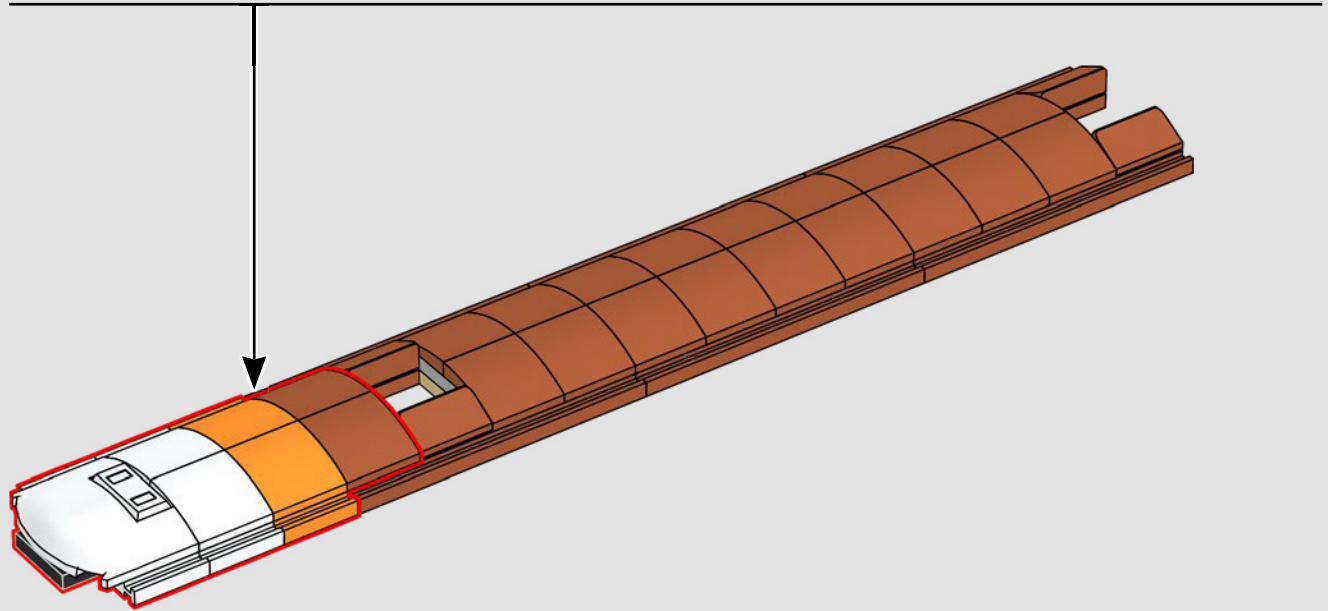
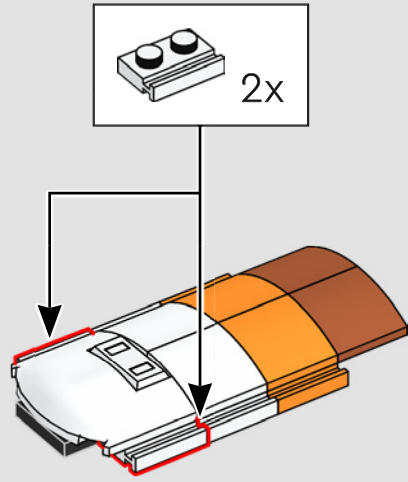

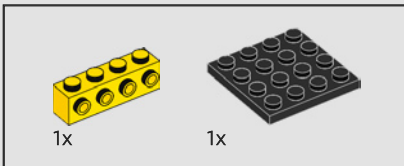
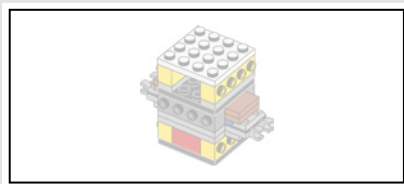

447

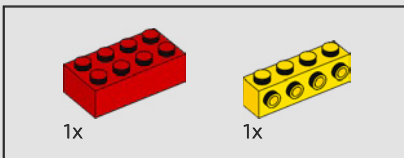
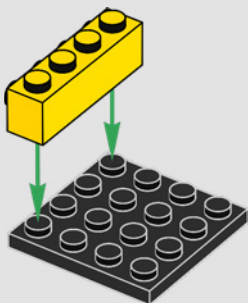

448

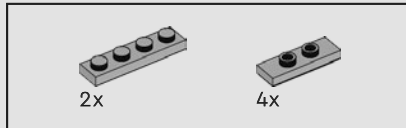
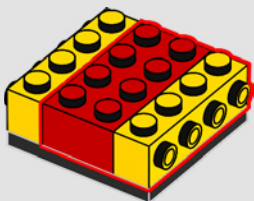

449

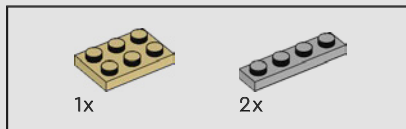

450

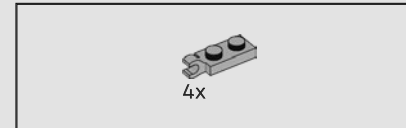
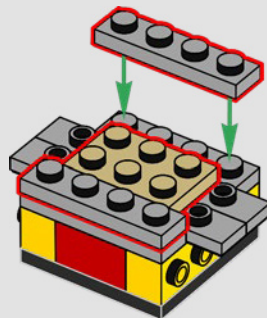

451

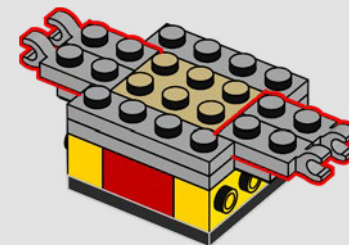

452

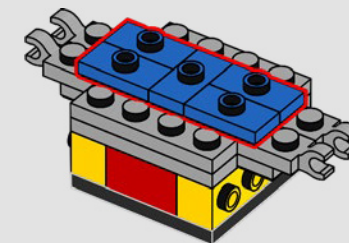

2x

453

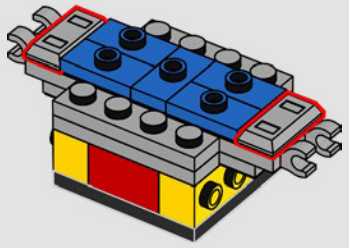

2x

2x

455

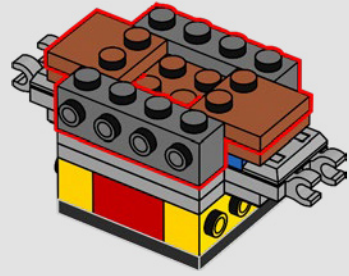

2x

457

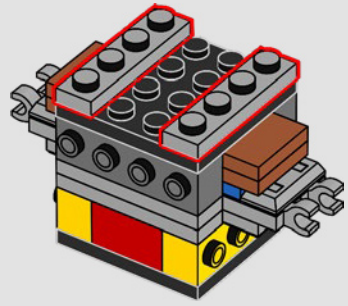

1x

454

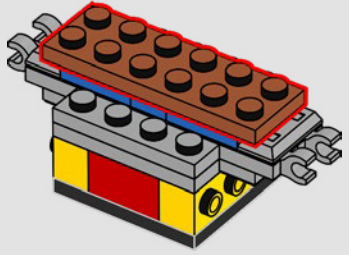

1x

456

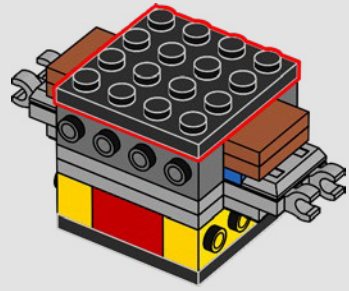

2x

458

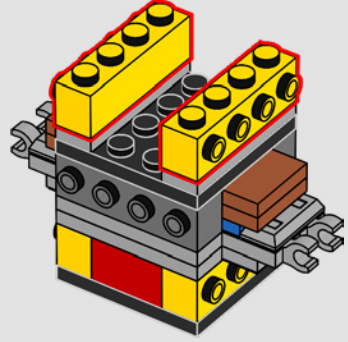

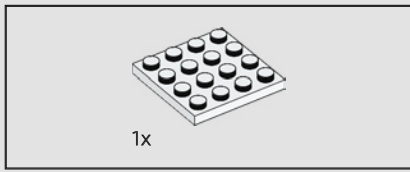

459

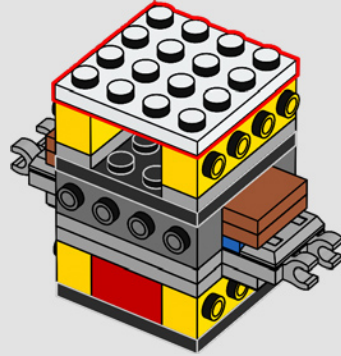

460

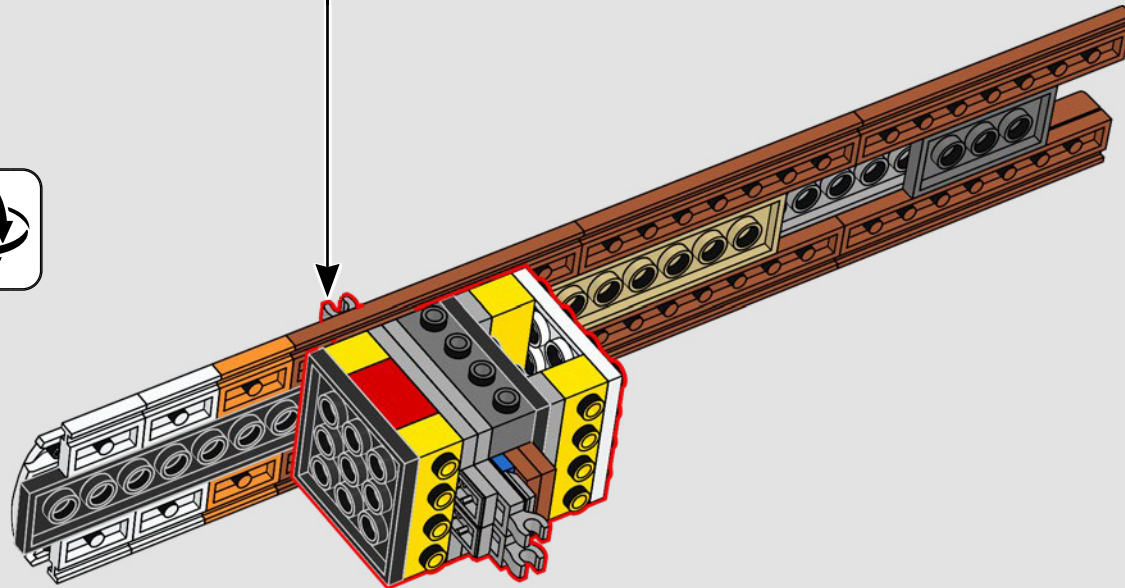

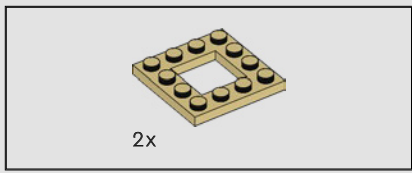

461

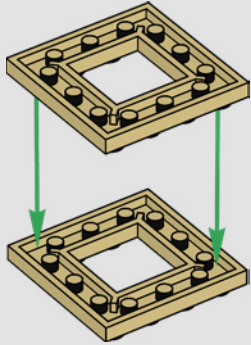

462

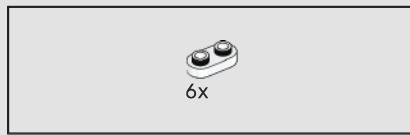
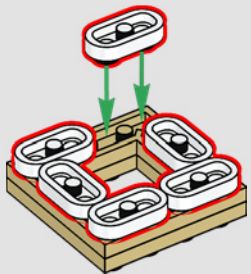

463

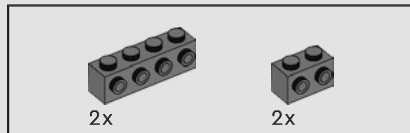
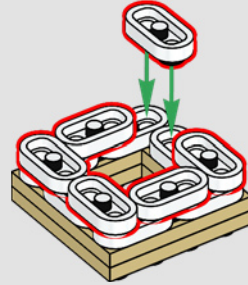

464

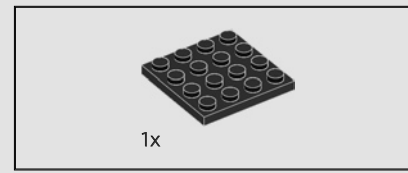
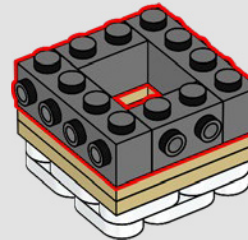
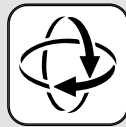

465

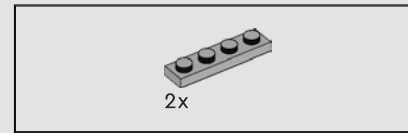
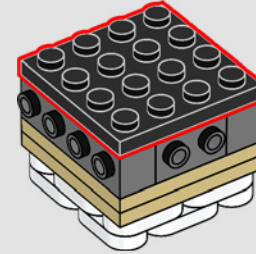

466

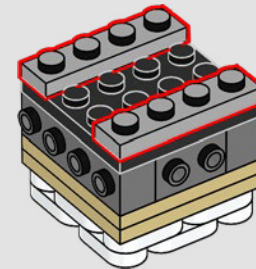



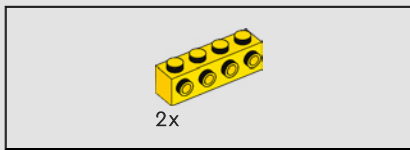

467

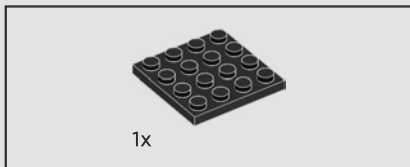
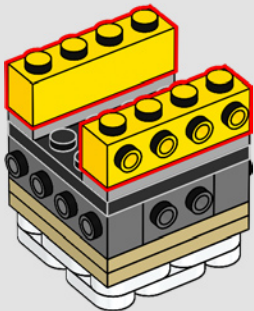

468

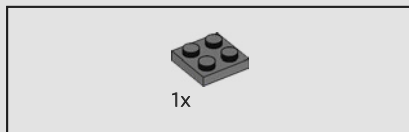
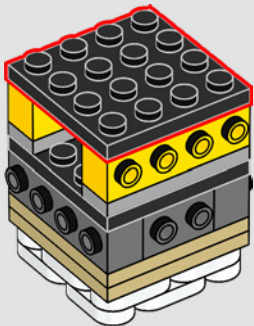

469

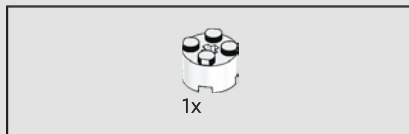
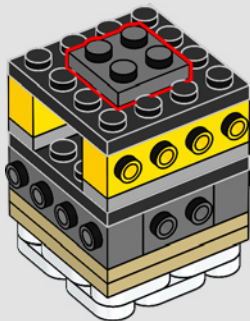

470

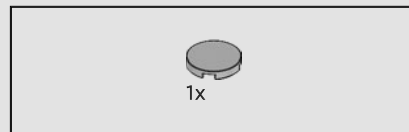
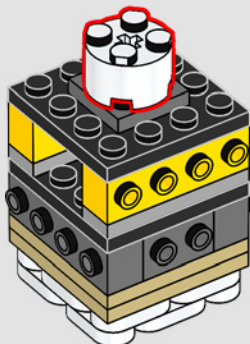

471

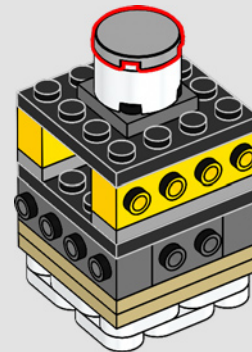

472

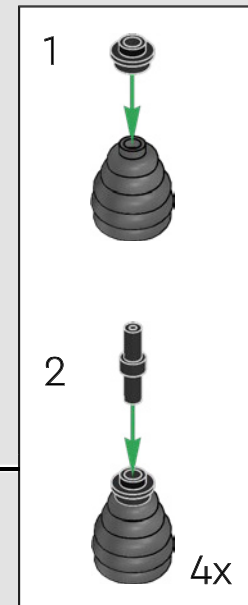
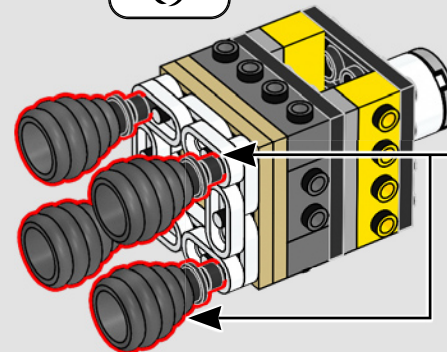
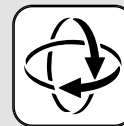

473

The LEGO® element used for the main engine nozzles was originally meant to depict a beehive but is called "Mini hat no. 54".

L'élément LEGO® utilisé pour les tuyères du moteur principal devait à l'origine représenter une ruche, mais il est appelé « Mini hat no. 54 » (« Petit chapeau no 54 »).

El elemento LEGO® utilizado para las toberas de los motores principales debía representar originalmente un panal de abejas, aunque terminó por recibir el nombre de "minisombrero n.º 54".

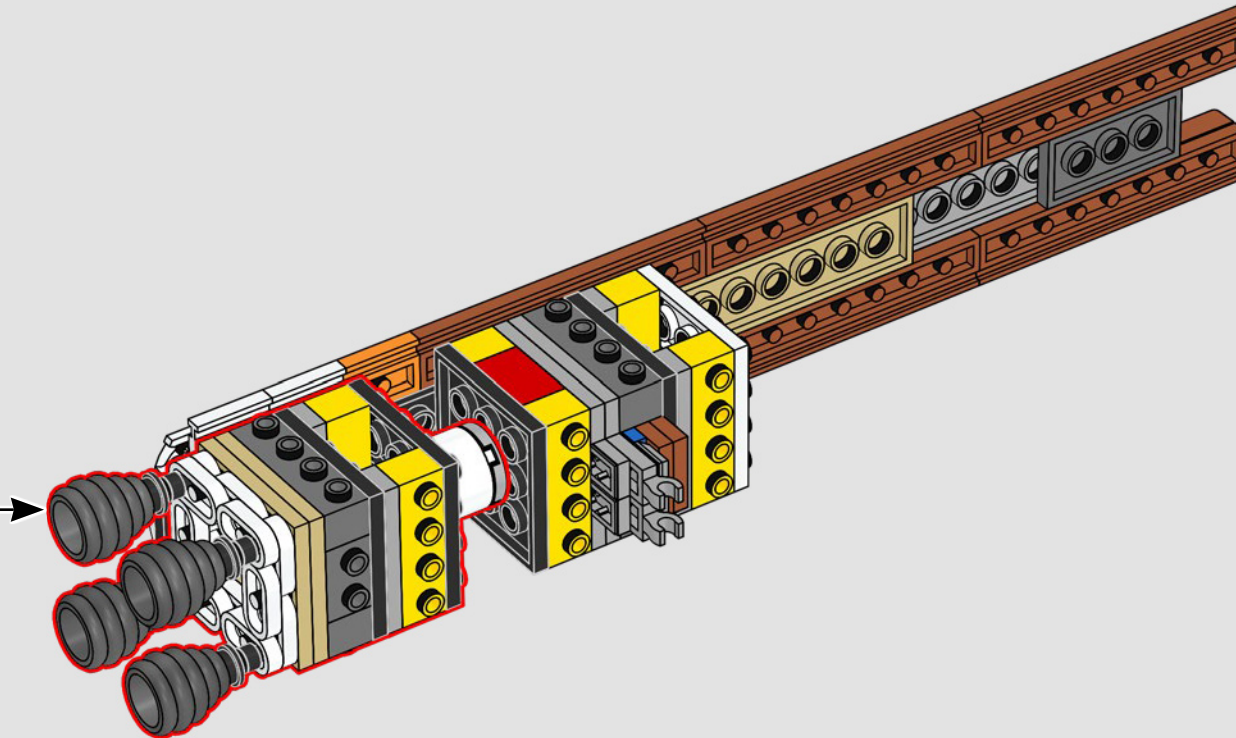

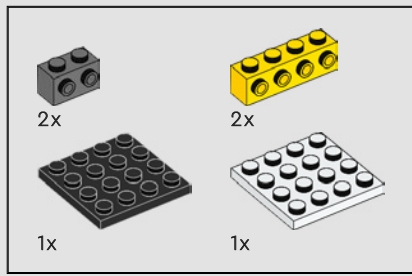

474

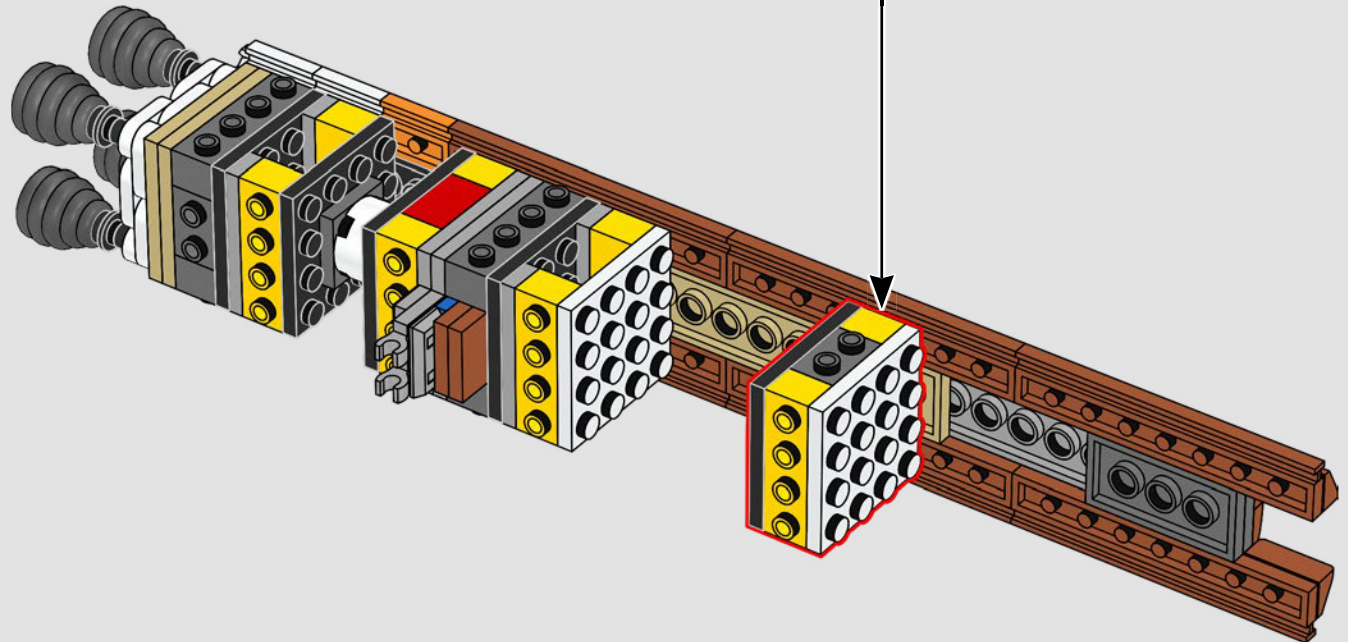
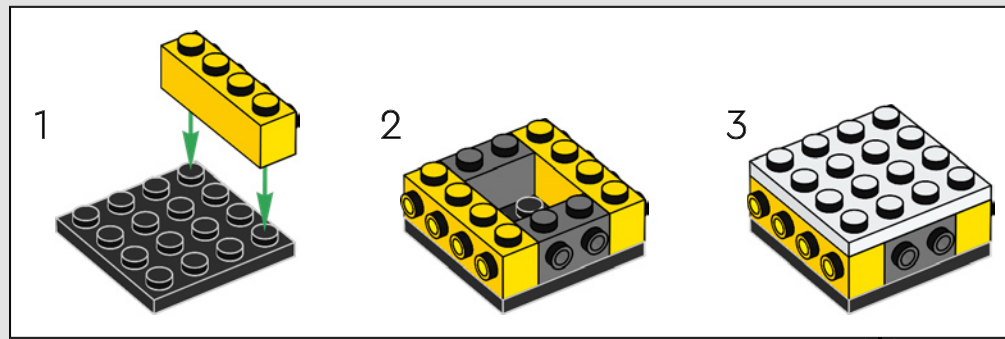

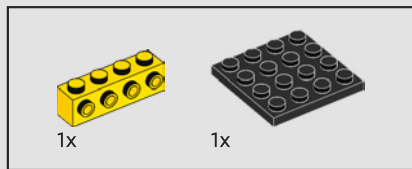

475

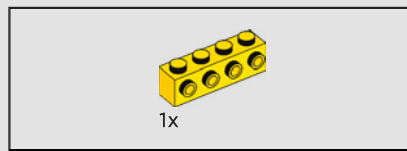
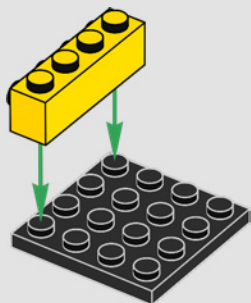

476

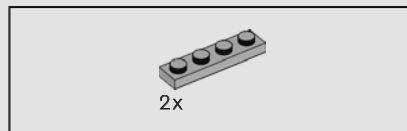
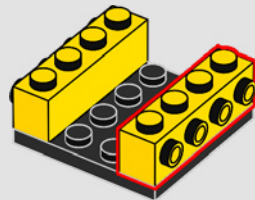

477

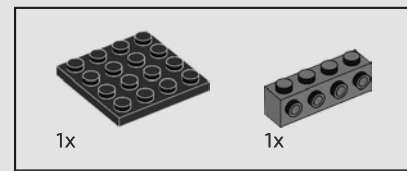
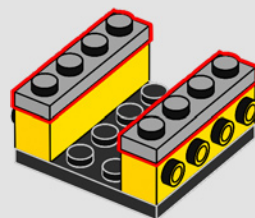

478

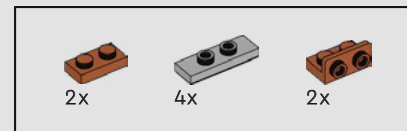
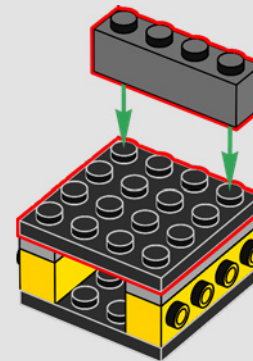

479

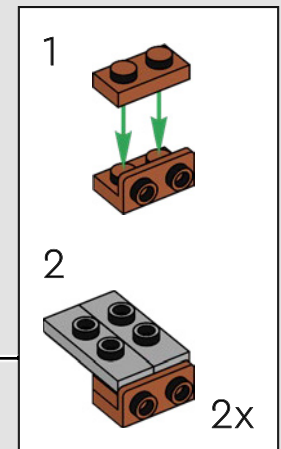
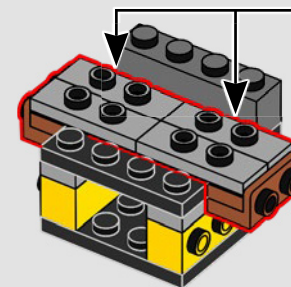

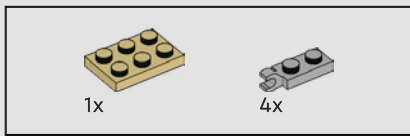

480

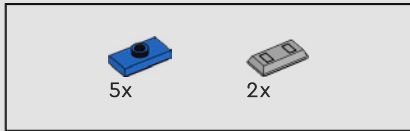
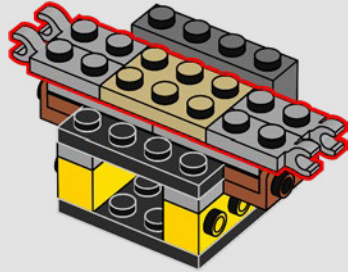

481

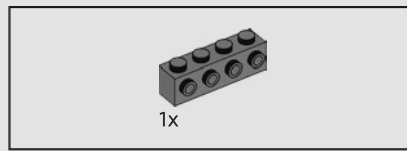
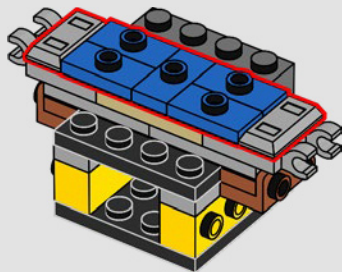

482

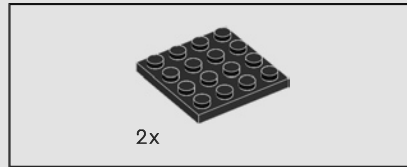
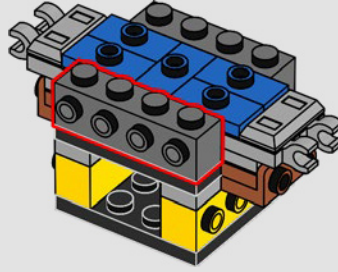

483

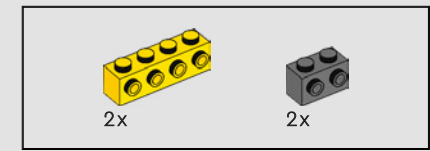
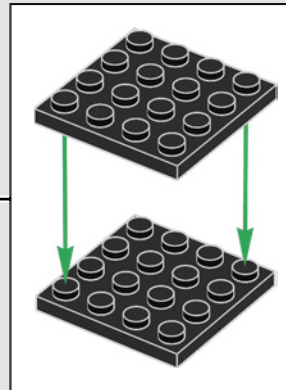
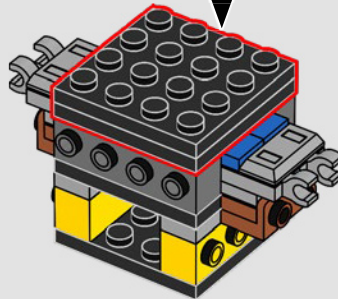

484

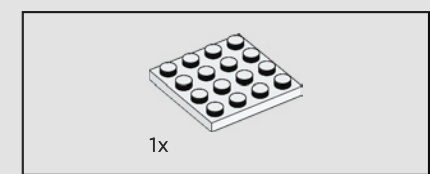
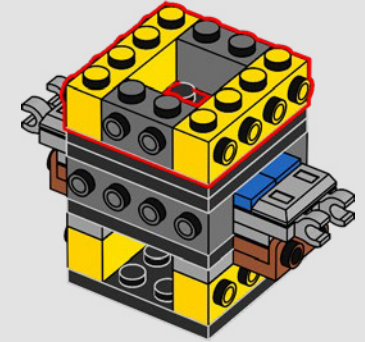

485

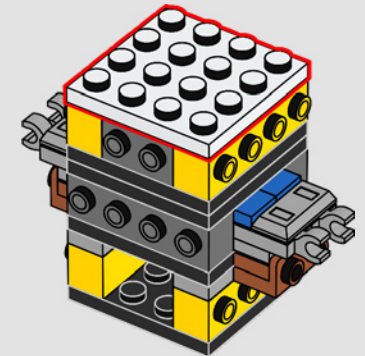

486

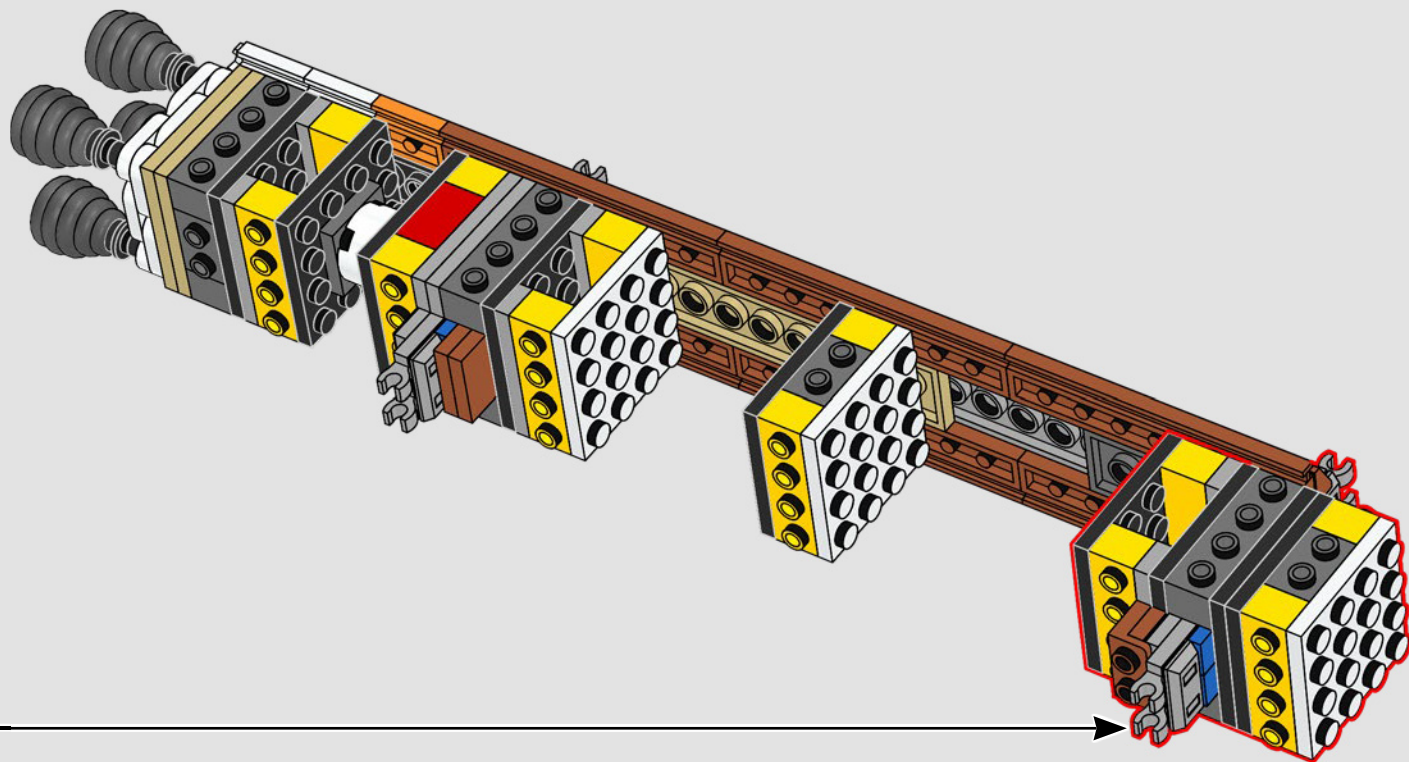

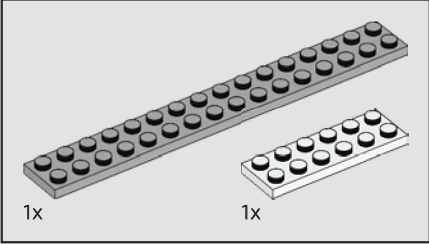
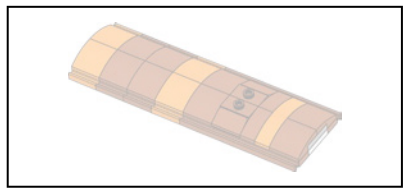

487

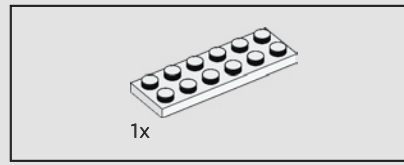
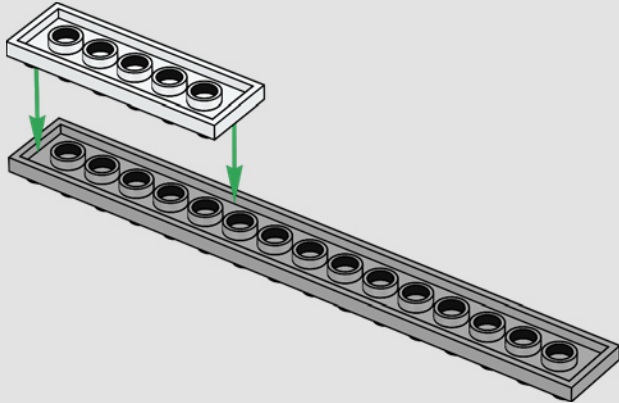

488

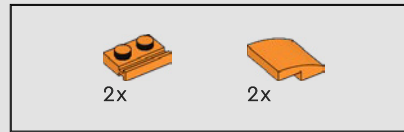
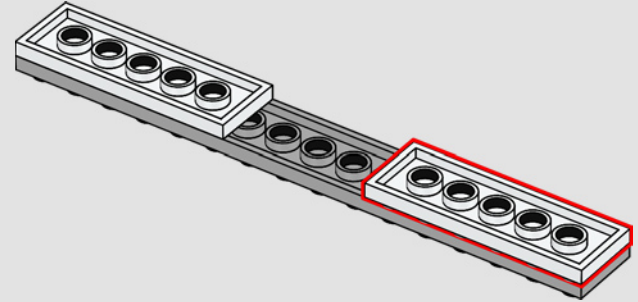

489

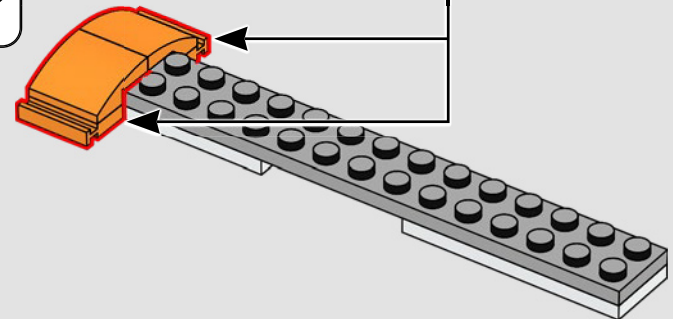
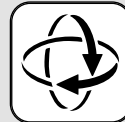
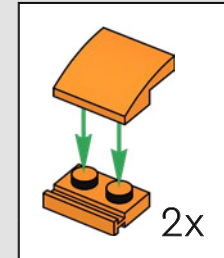

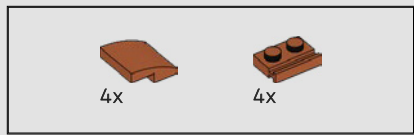

490

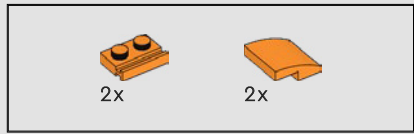
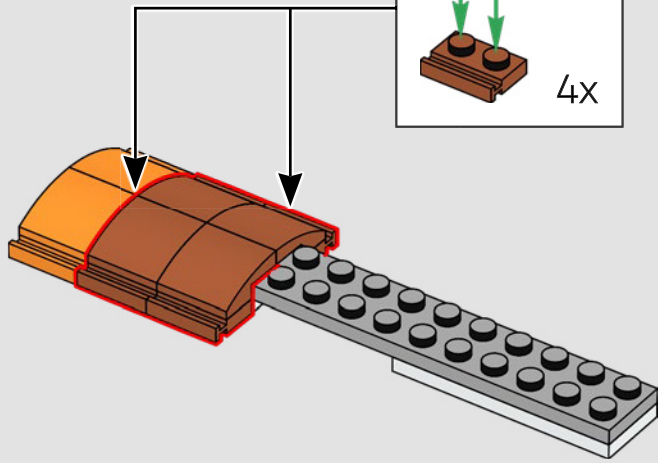
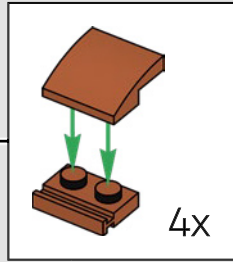

491

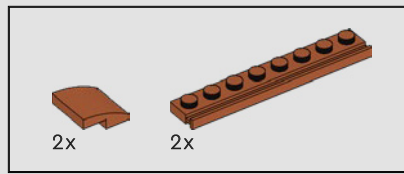
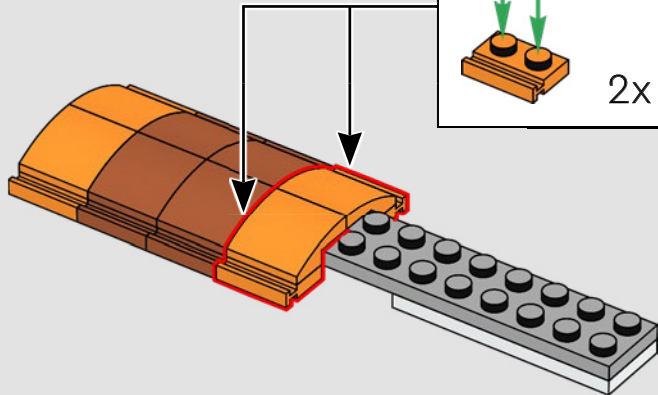
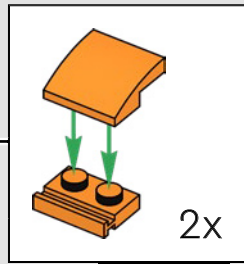

492

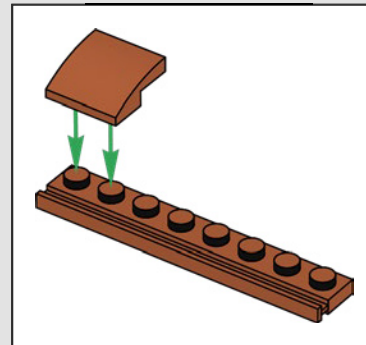
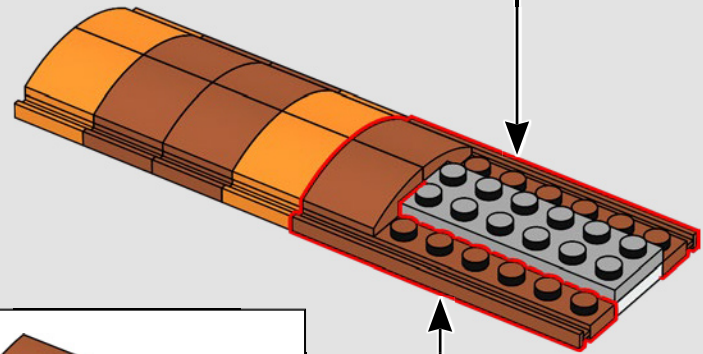
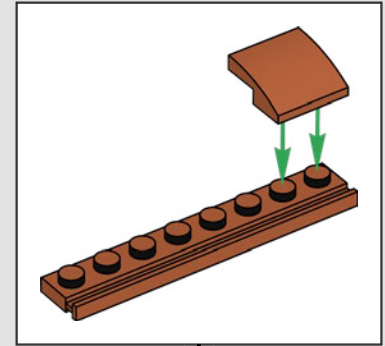



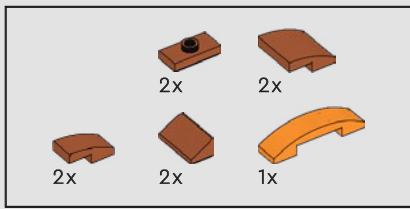

493

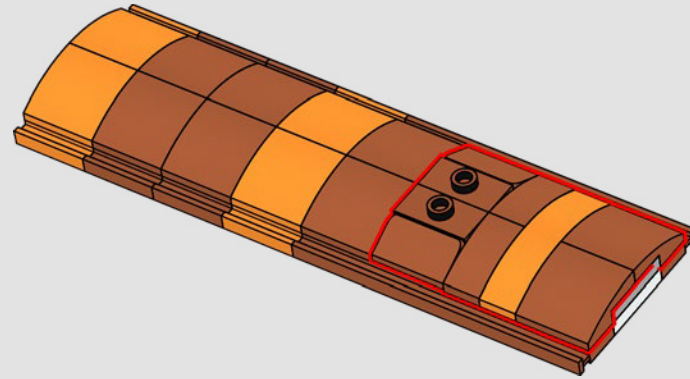

494

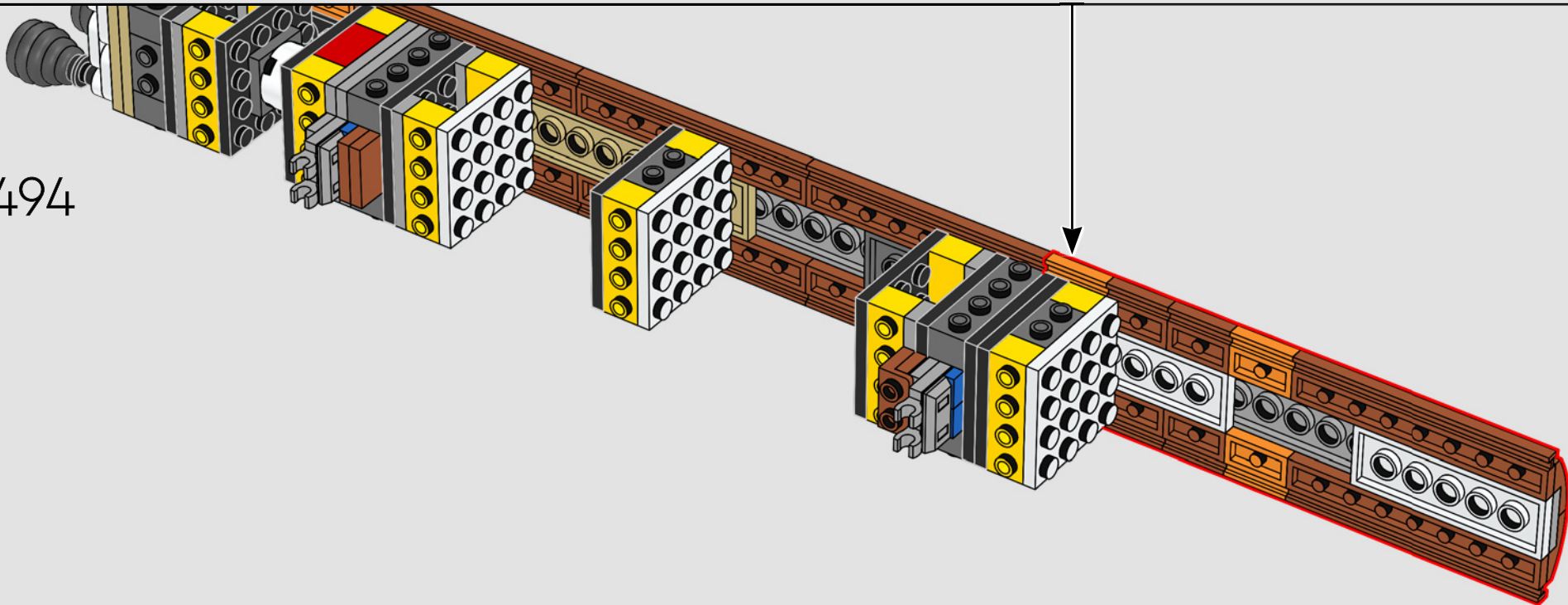

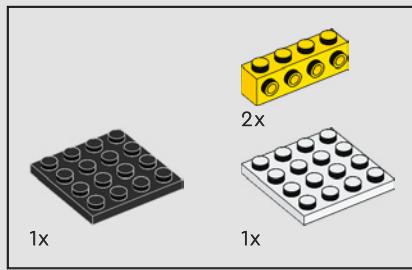

495

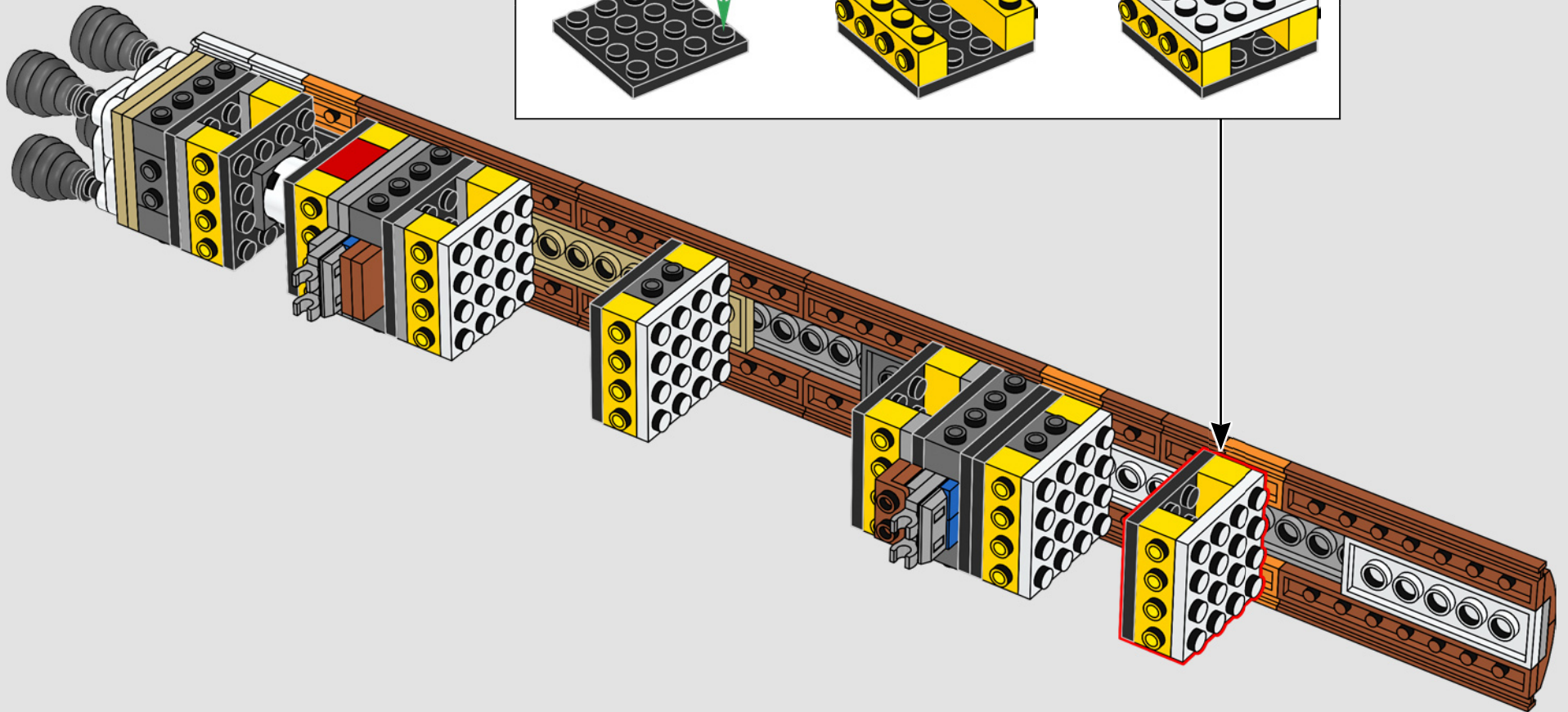
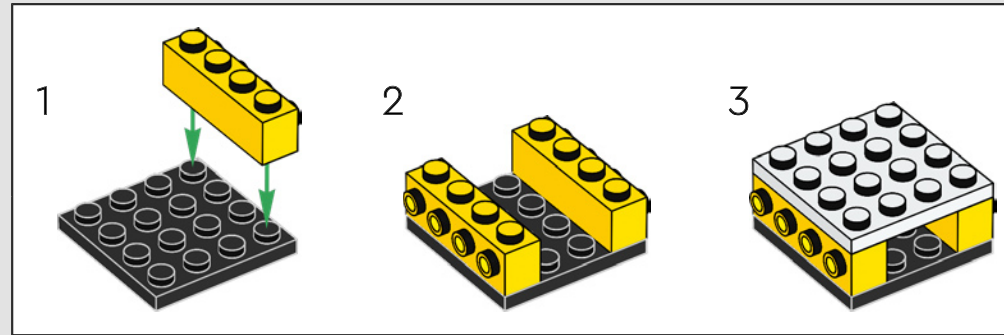

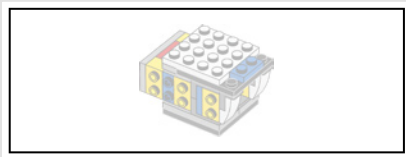

496

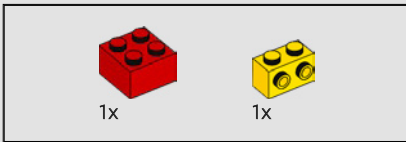
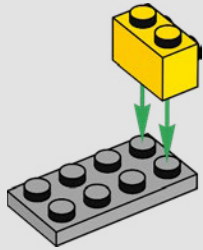

497

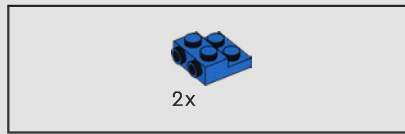
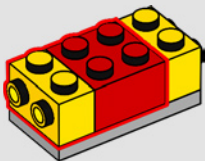

498

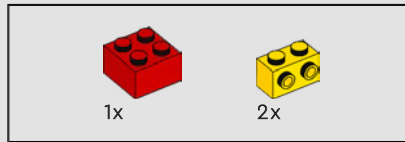
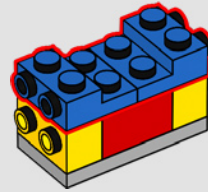

499

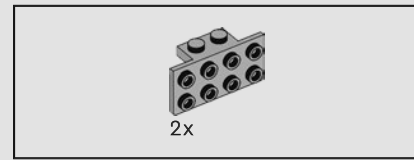
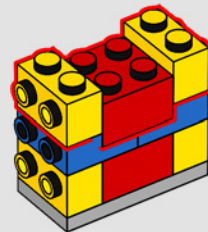

500

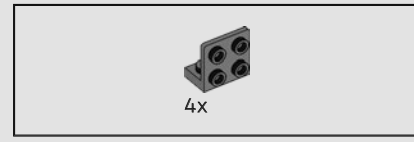
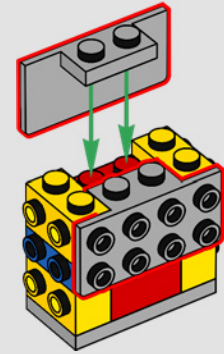

501

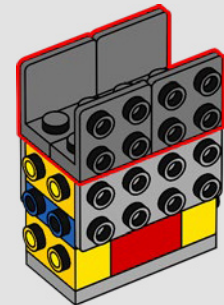

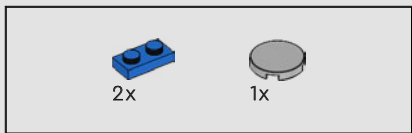

502

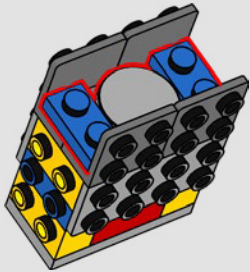

503

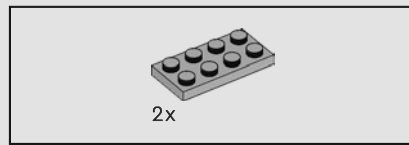
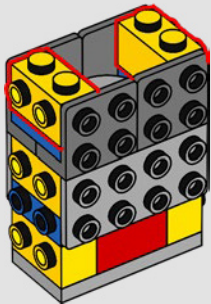

504

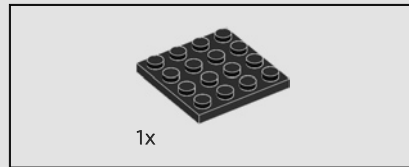
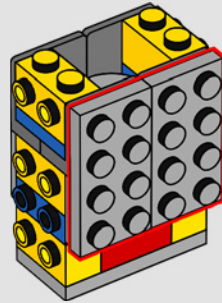

505

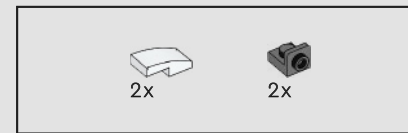
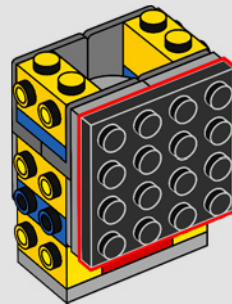

506

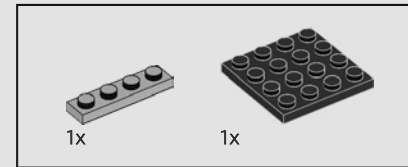
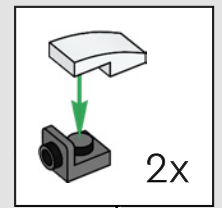
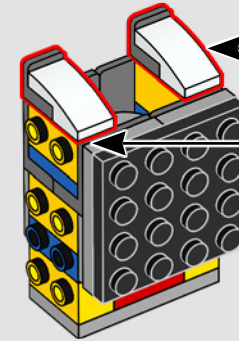

507

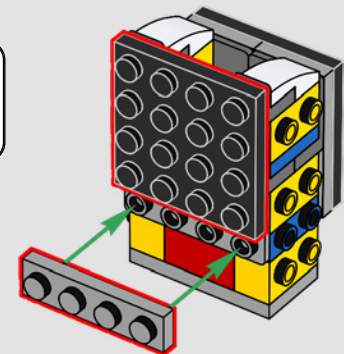
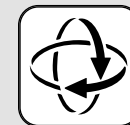

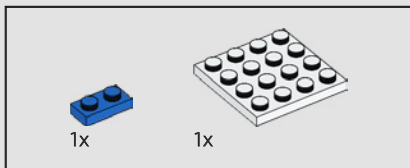

508

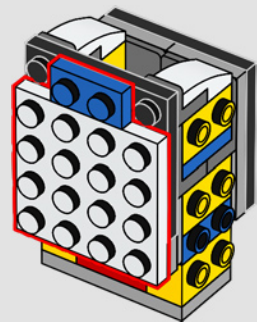

509

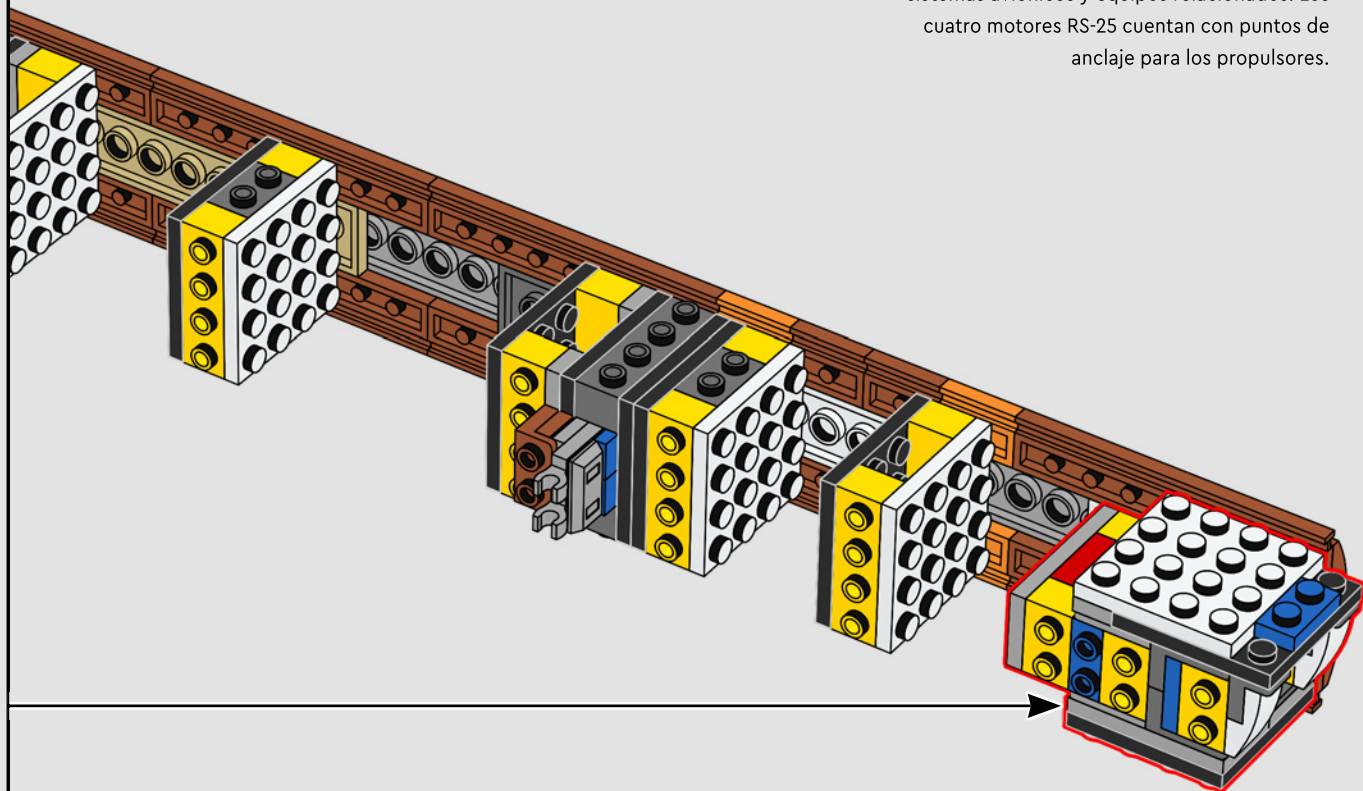

The core stage was developed specifically for the SLS. It consists of propellant tanks, avionics and related equipment. The four RS-25 engines provide attachment points for the boosters.

L'étage principal a été développé spécifiquement pour le SLS. Il se compose de réservoirs de propergol, d'avionique et d'équipements connexes. Les quatre moteurs RS-25 servent de points d'attache aux propulseurs d'appoint.

La etapa central se desarrolló específicamente para el SLS. Consta de tanques de propelente, sistemas aviónicos y equipos relacionados. Los cuatro motores RS-25 cuentan con puntos de anclaje para los propulsores.

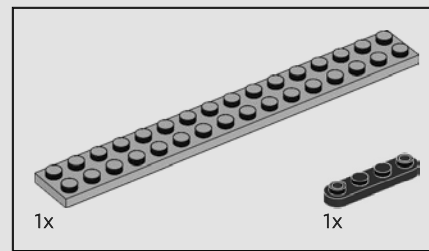

510

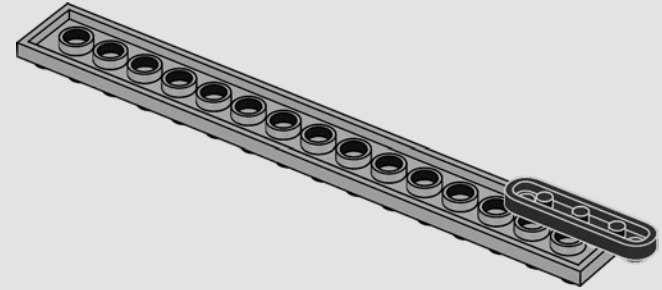

511

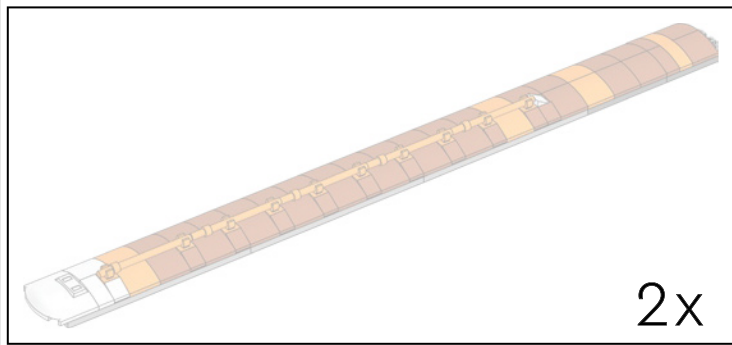
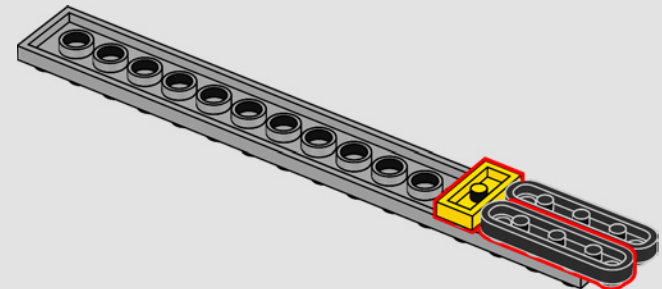

2x

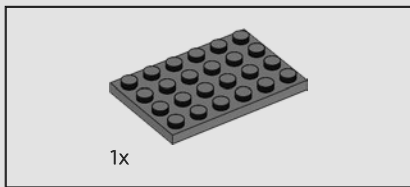

512

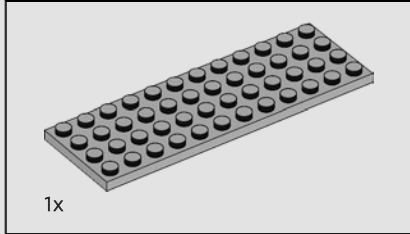
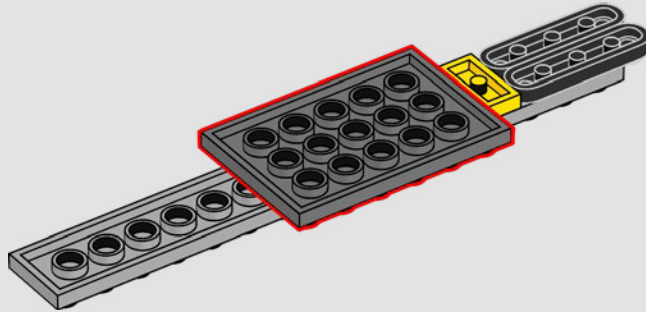

513

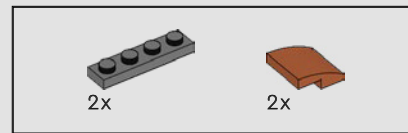
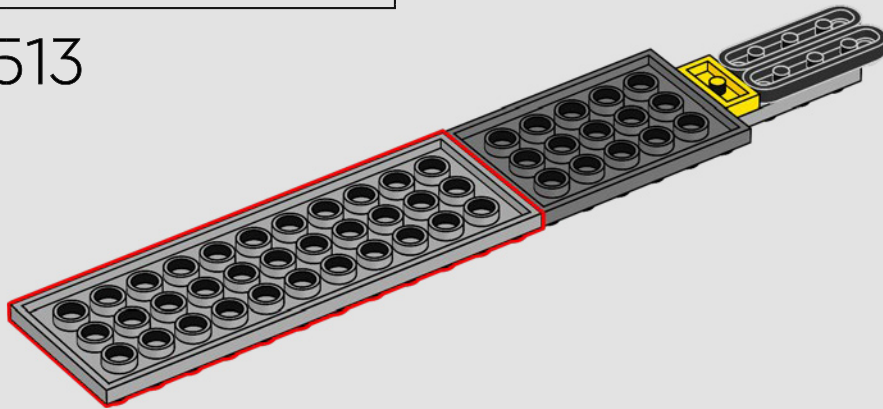

514

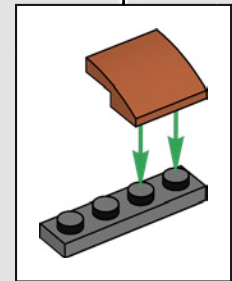
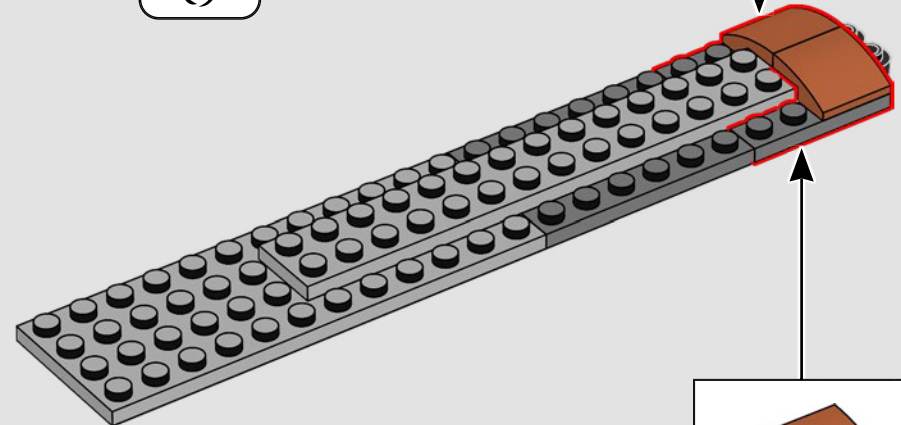
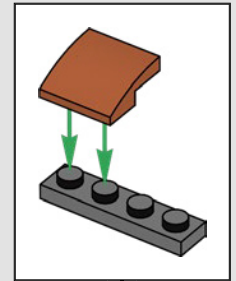
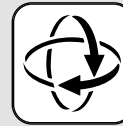

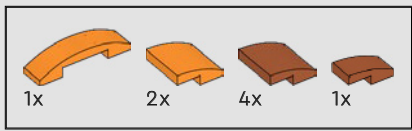

515

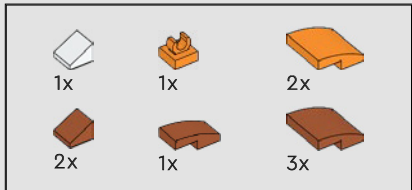
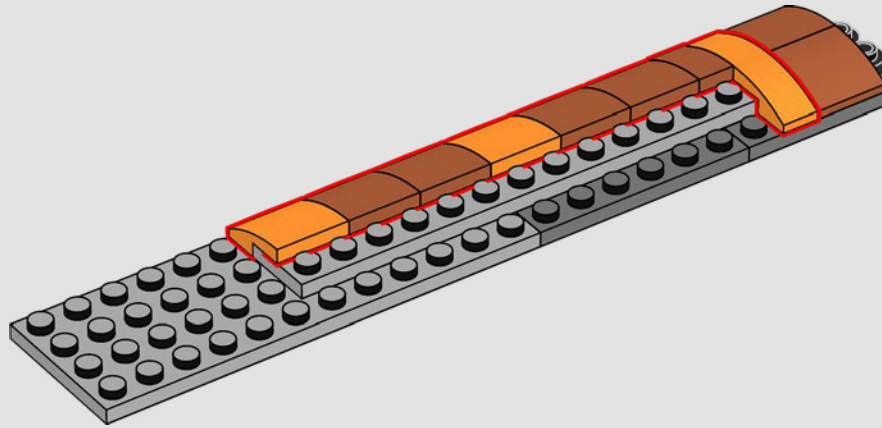

516

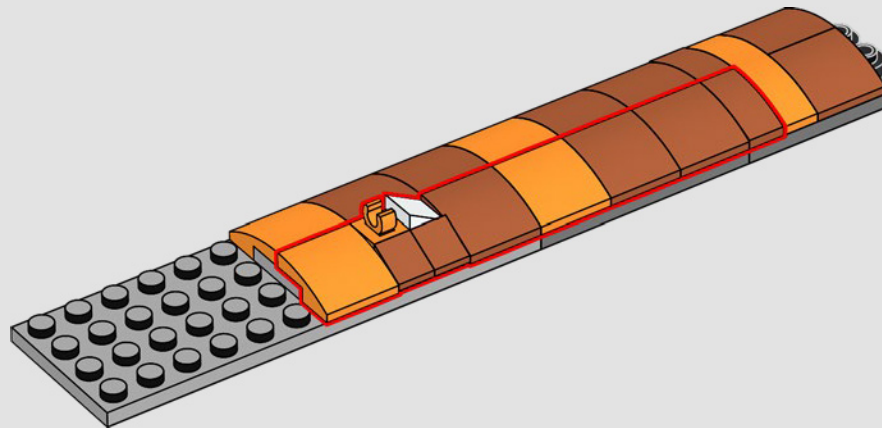



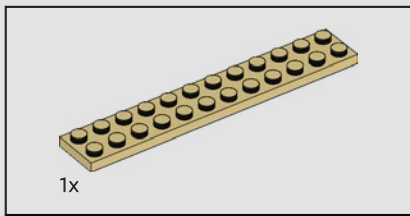

517

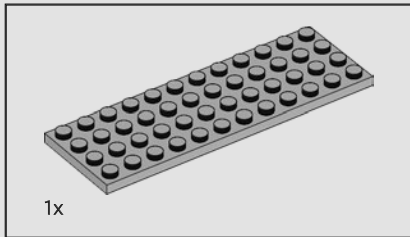
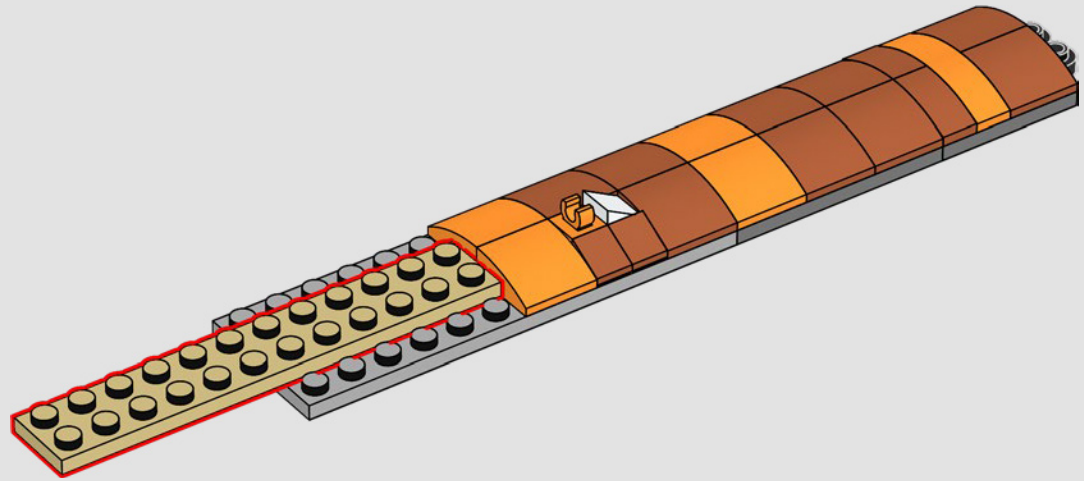

518

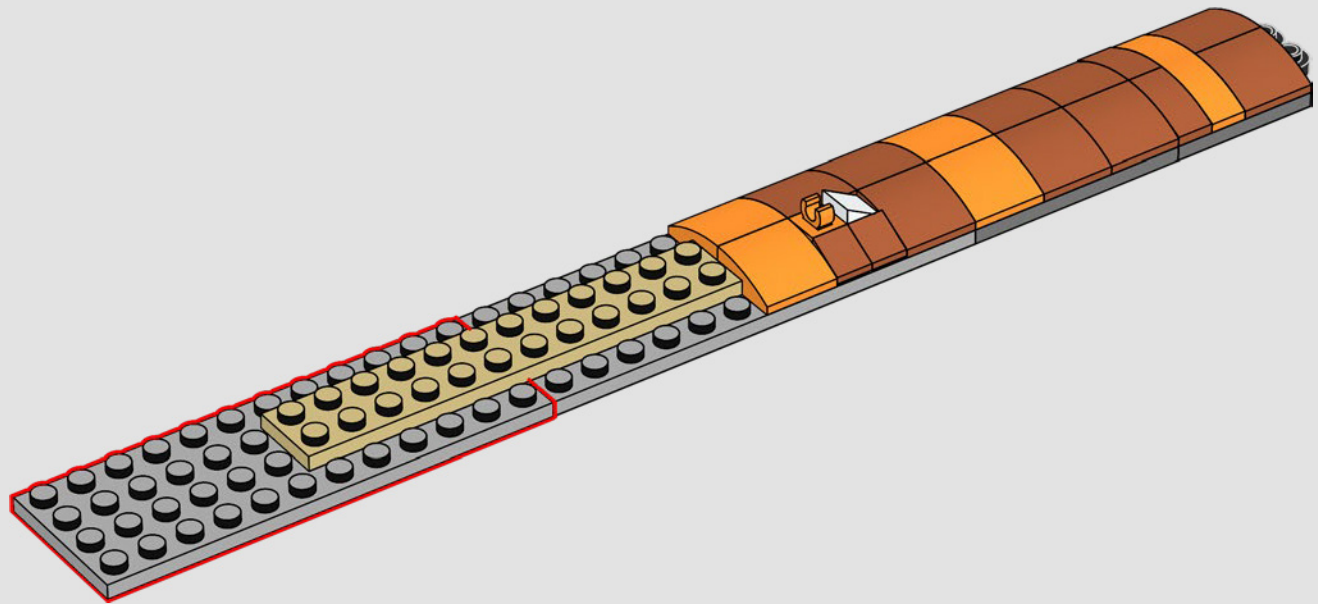

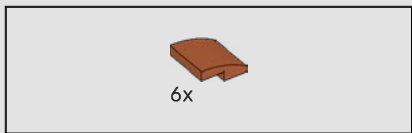

519

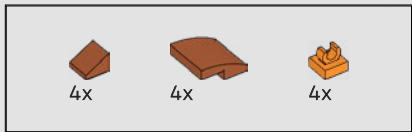
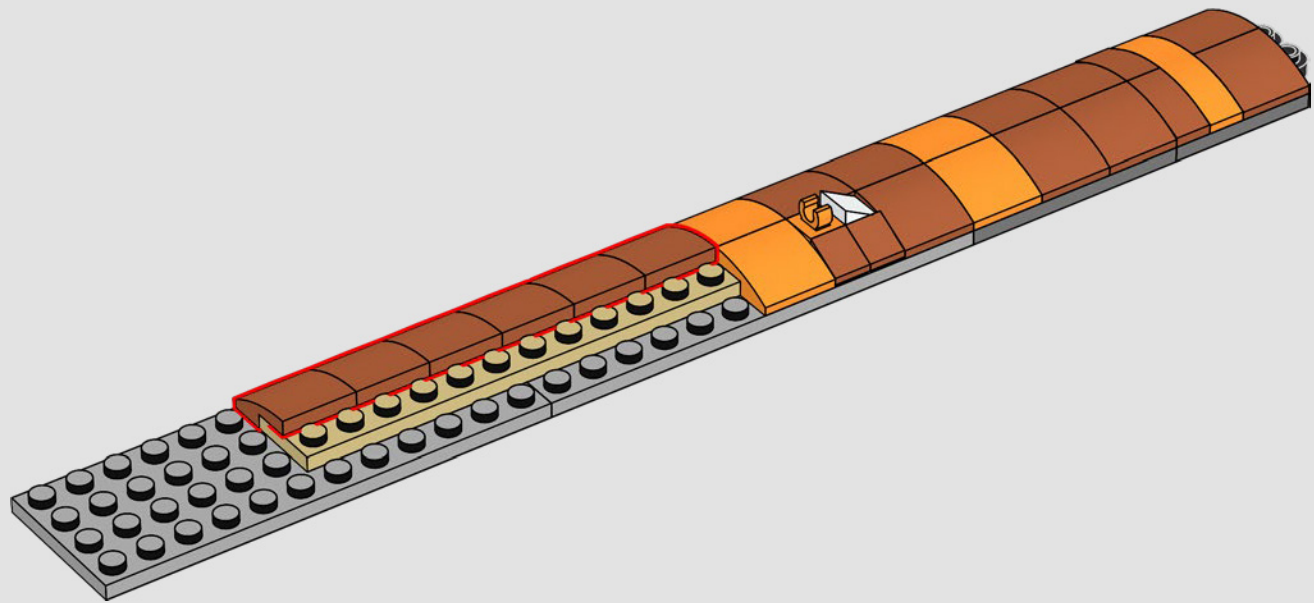

520

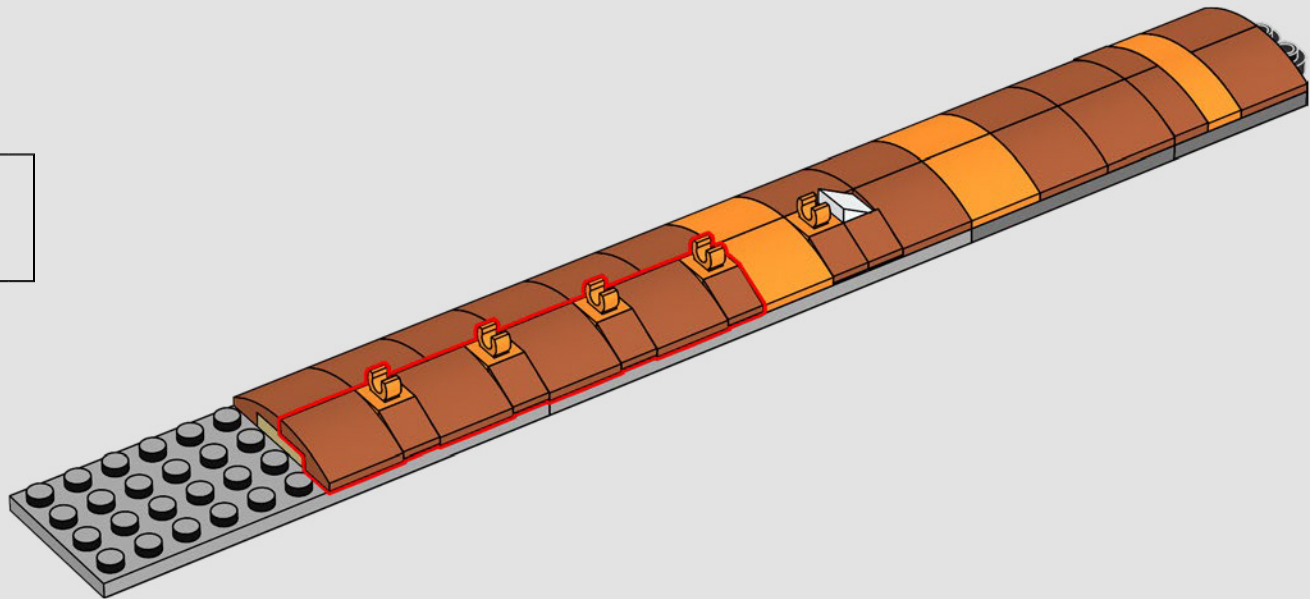

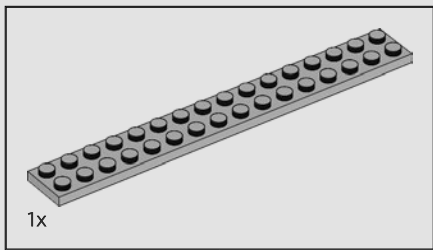

1x

521

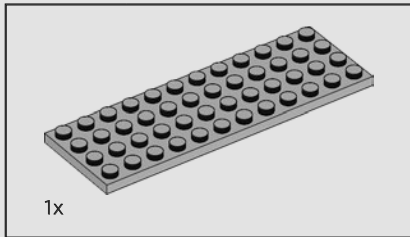
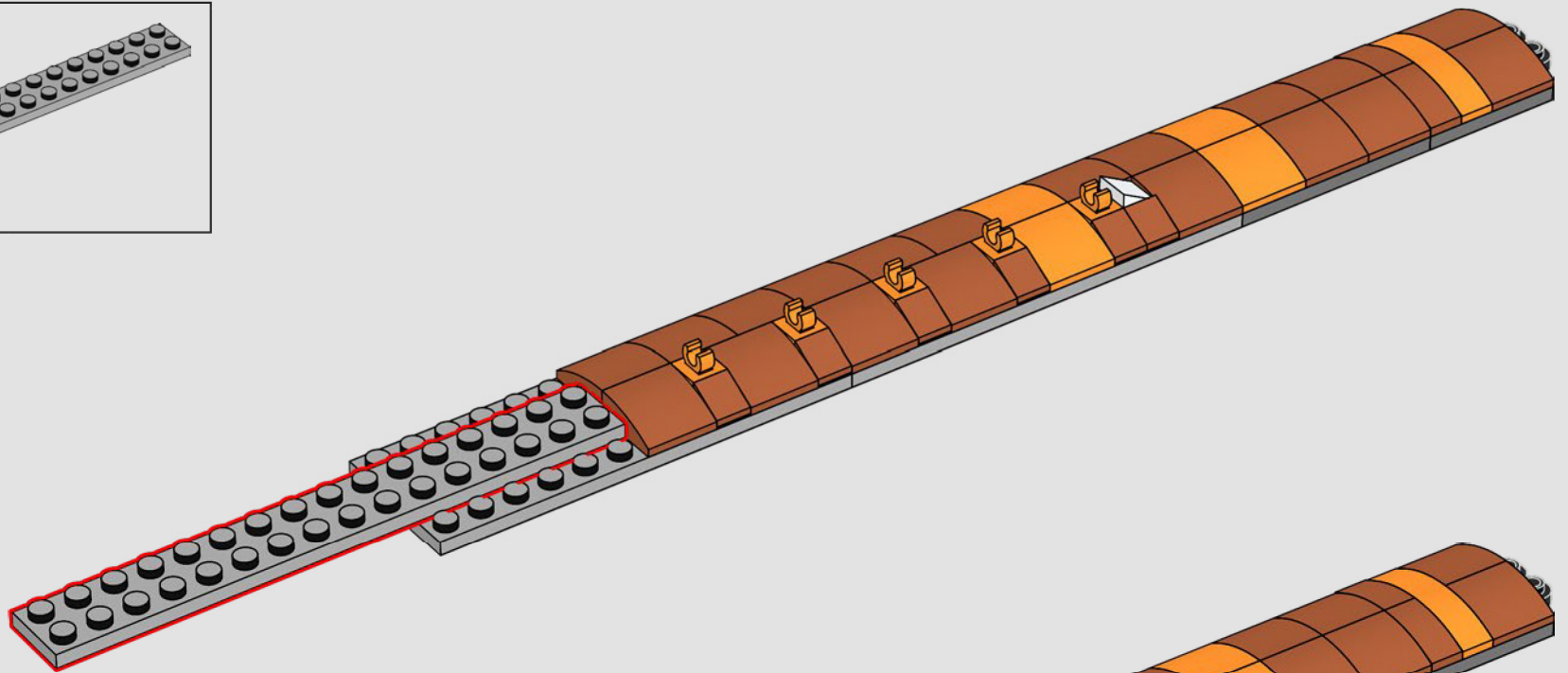

1x

522

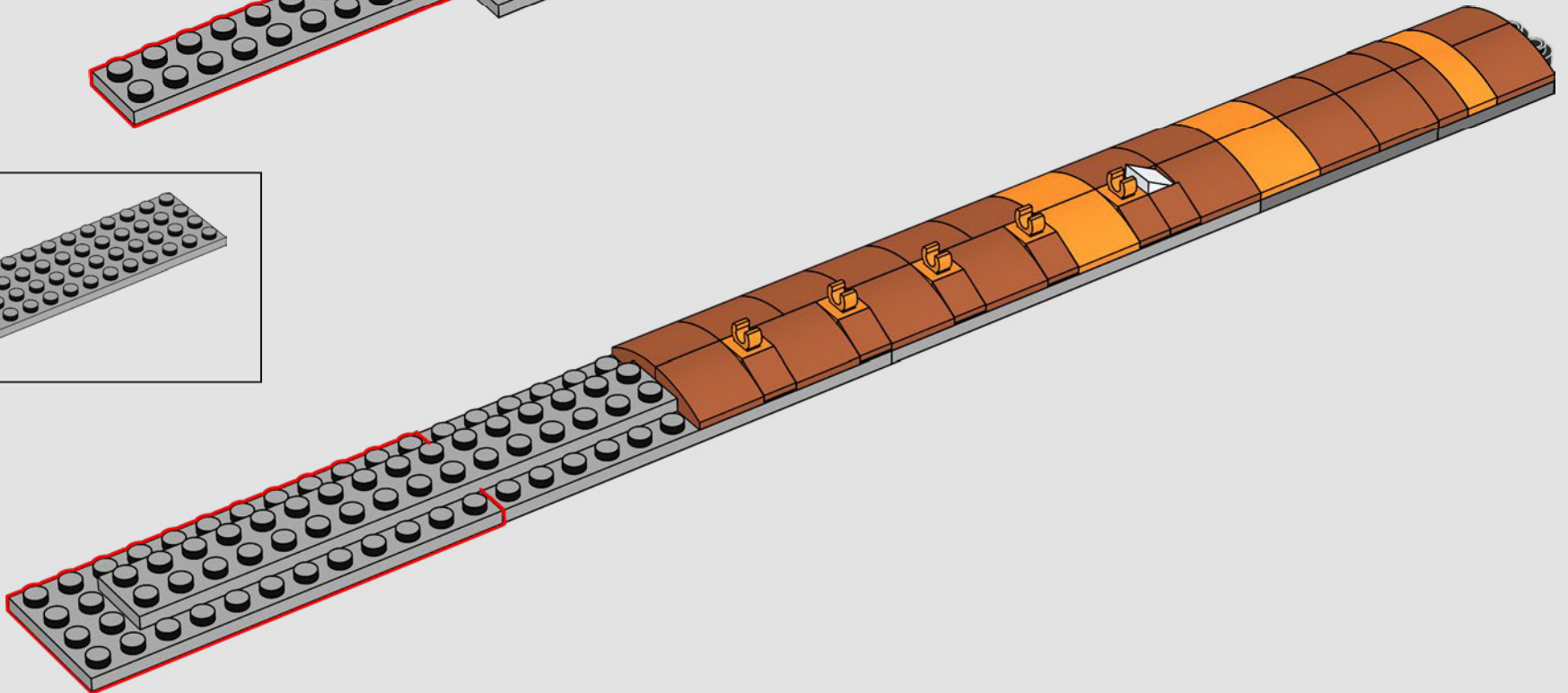

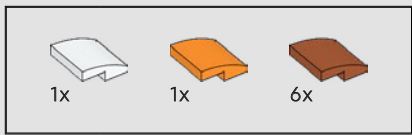

523

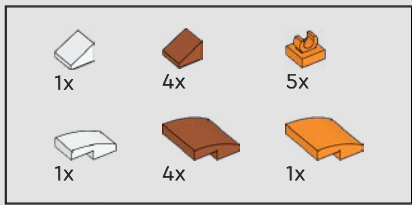
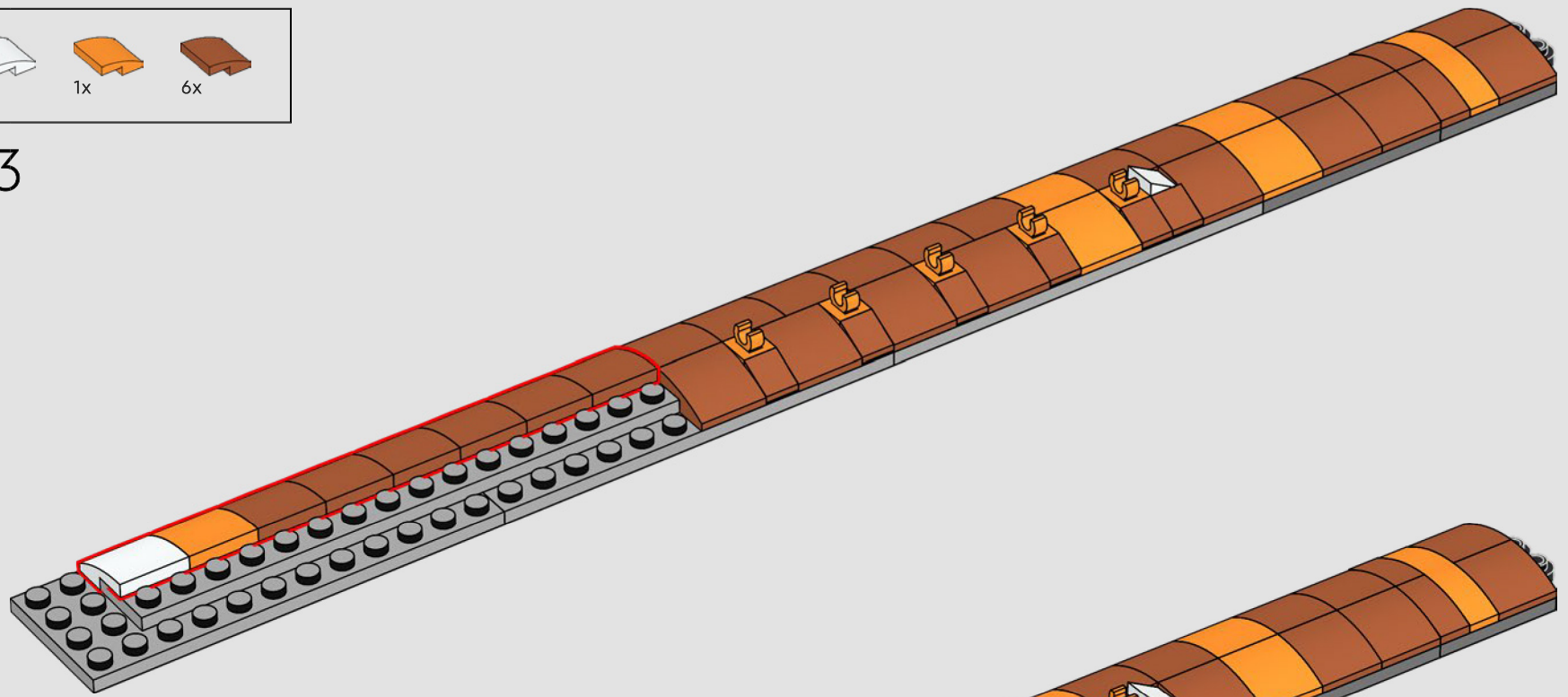

524

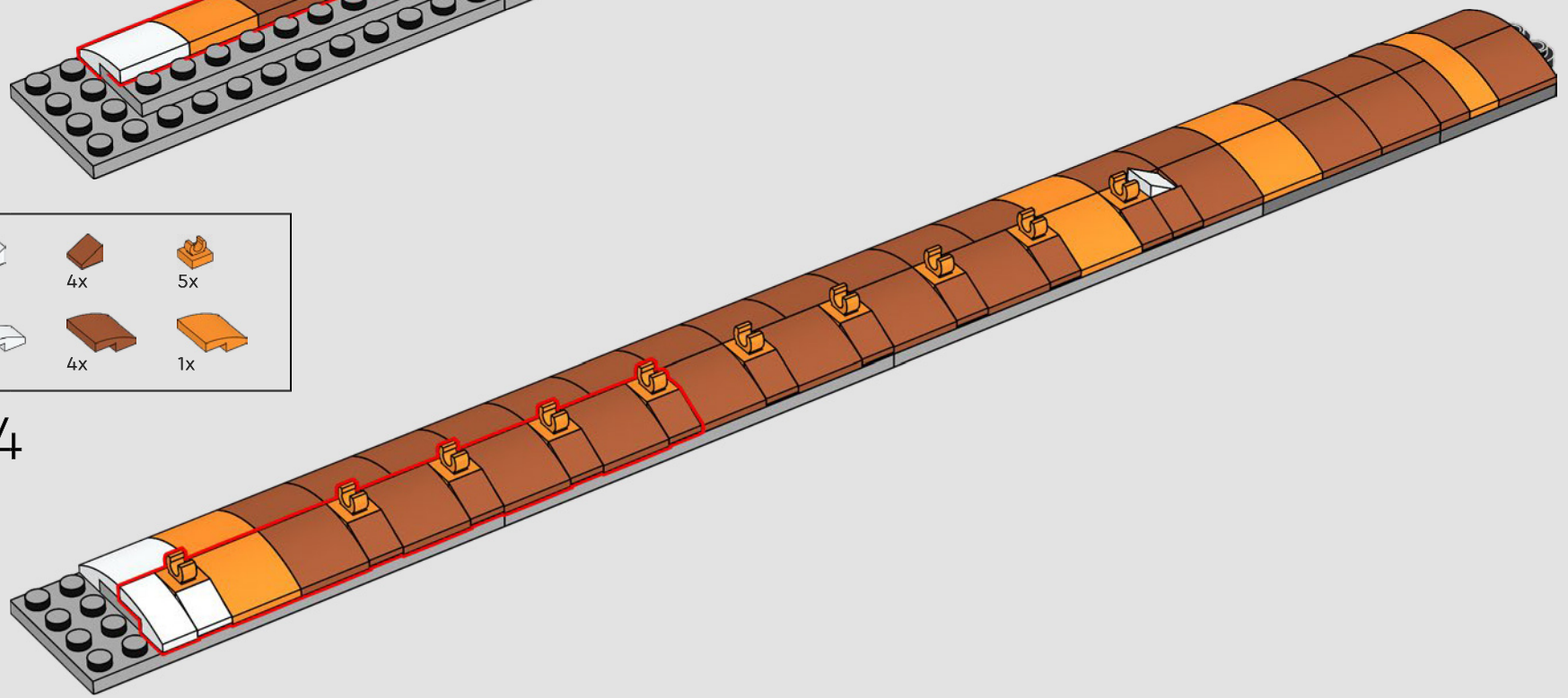

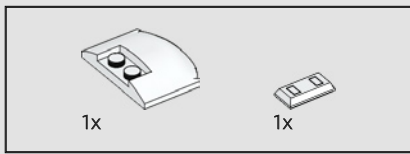

525

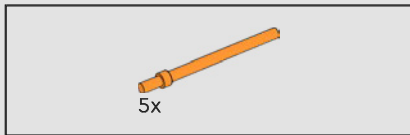
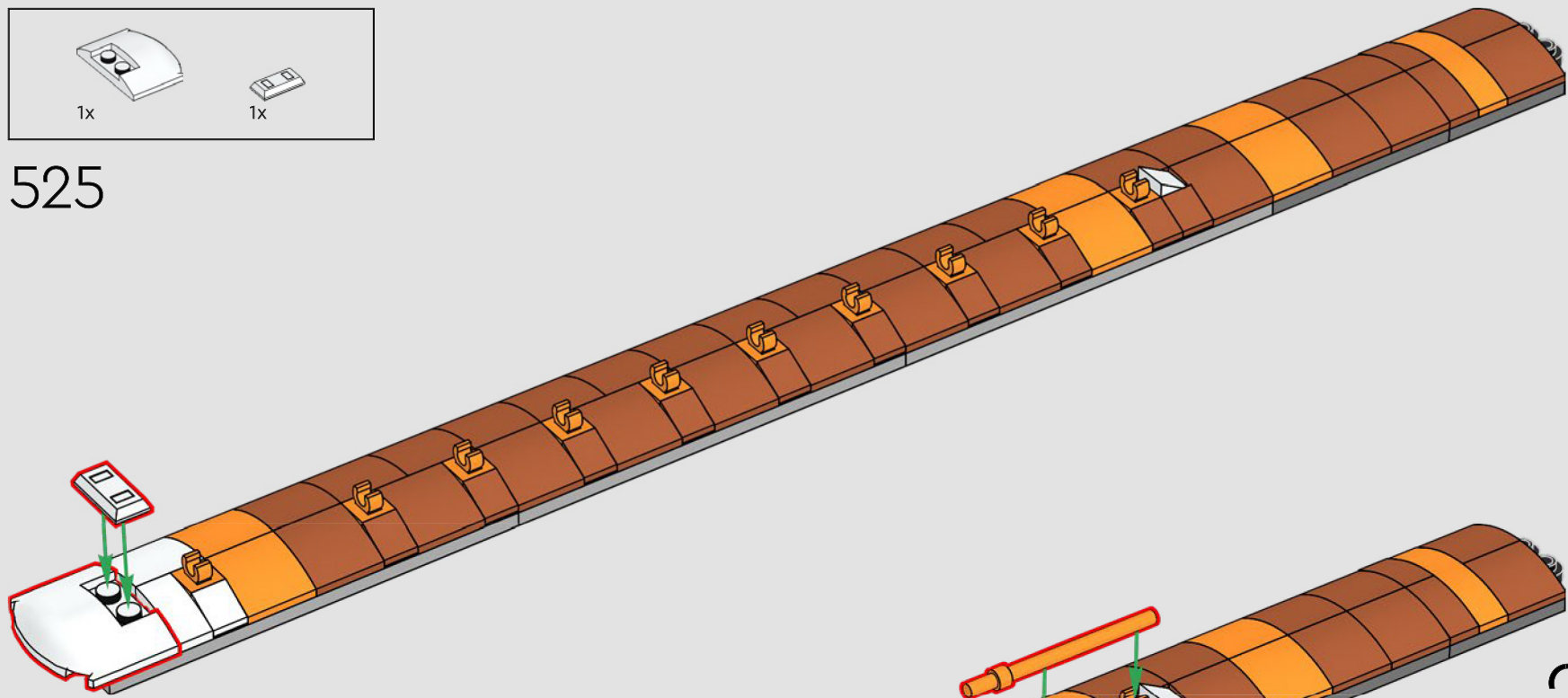

526

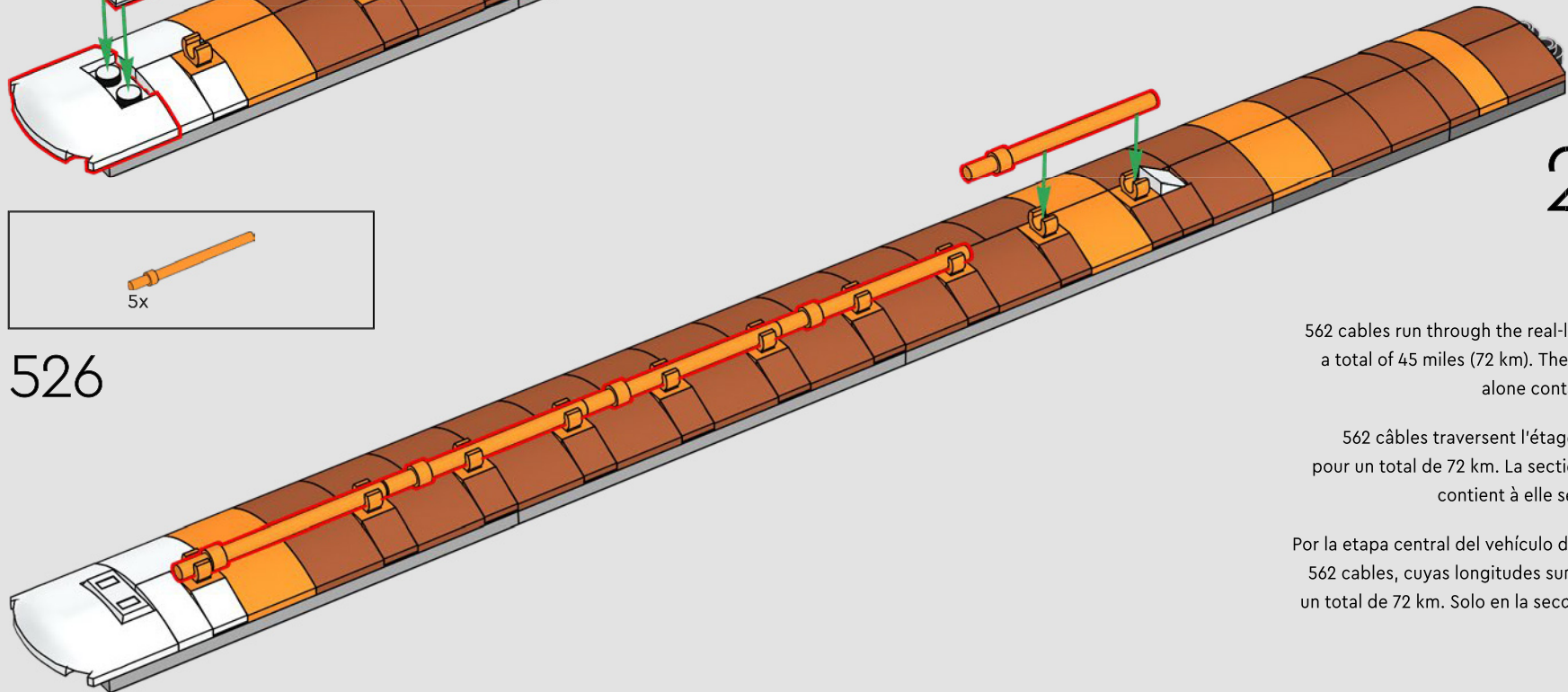

2x

562 cables run through the real-life core stage – a total of 45 miles (72 km). The engine section alone contains 231 cables.

562 câbles traversent l'étage principal réel, pour un total de 72 km. La section des moteurs contient à elle seule 231 câbles.

Por la etapa central del vehículo de verdad pasan 562 cables, cuyas longitudes sumadas alcanzan un total de 72 km. Solo en la sección de motores hay 231 cables.

527

The multiple colors of the first rocket stage are due to different types of foam insulation. This coating gets darker the longer it is exposed to sunlight.

Les multiples couleurs du premier étage de la fusée sont dues aux différents types de mousse isolante. Ce revêtement devient de plus en plus foncé selon la durée d'exposition à la lumière du soleil.

Los distintos colores de la primera etapa del cohete provienen del uso de diversos tipos de espumas aislantes. El revestimiento se va oscureciendo conforme se expone a la luz solar.

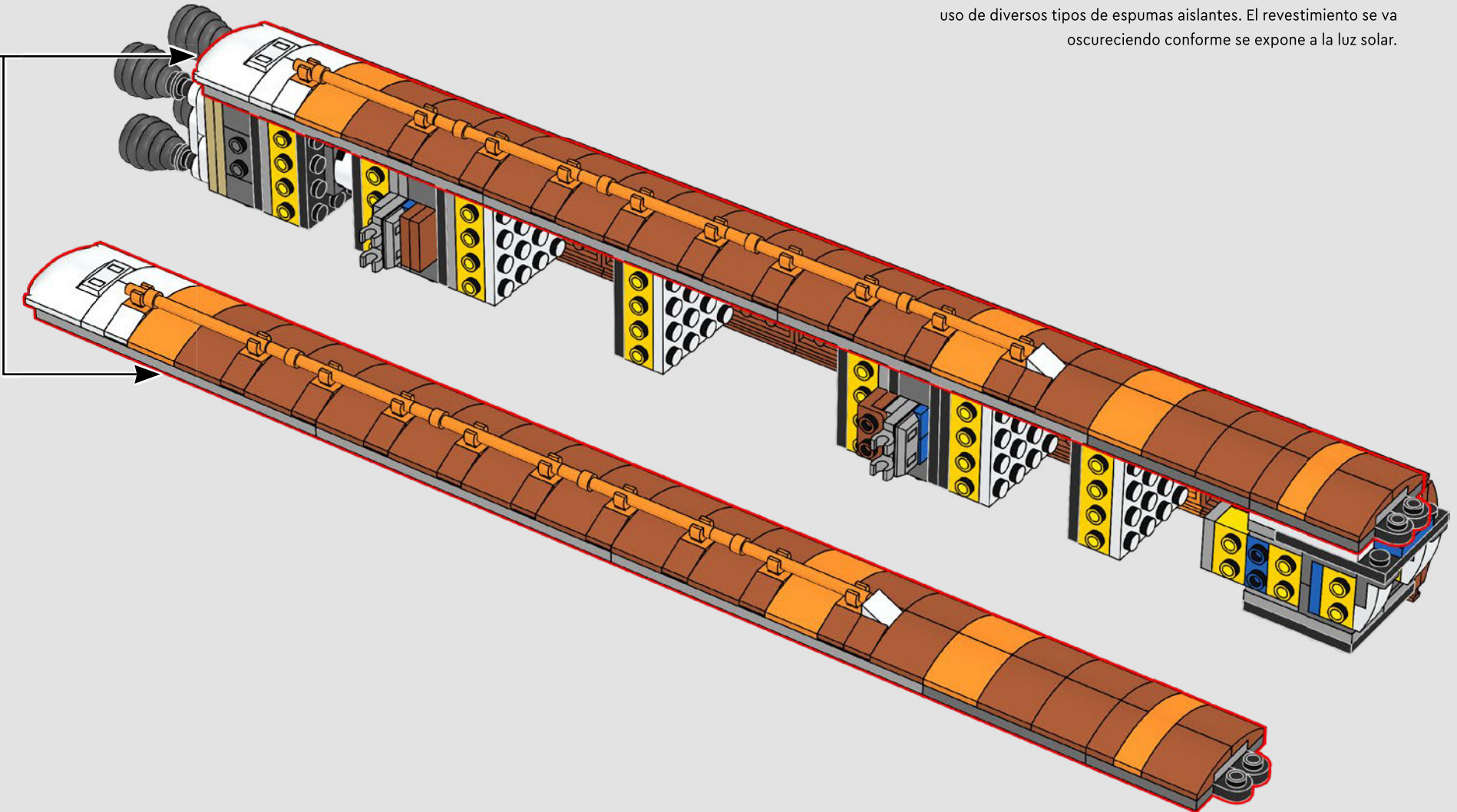

528

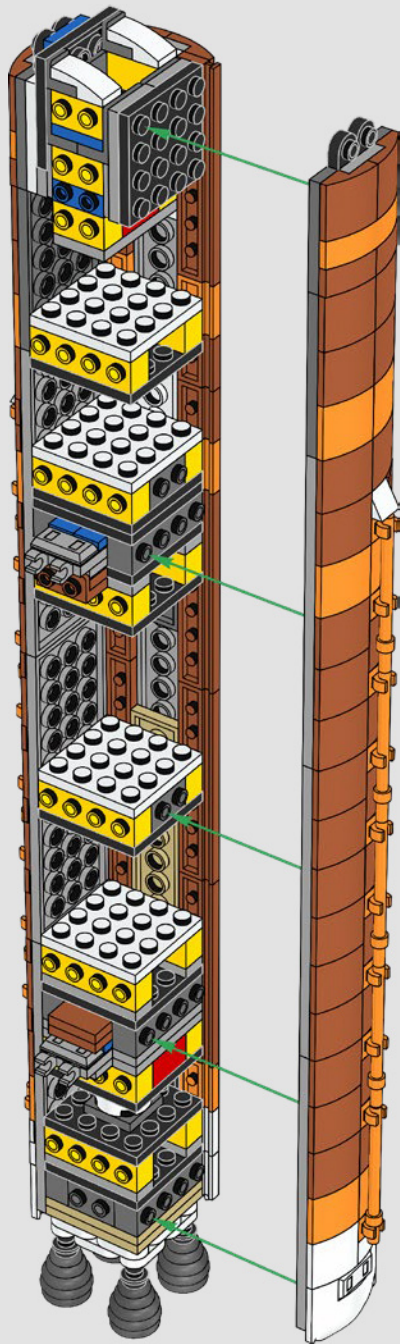

529

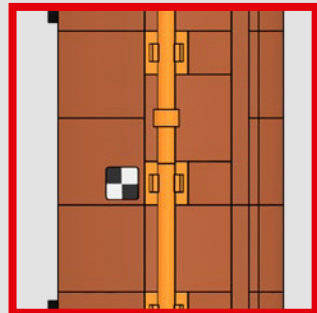
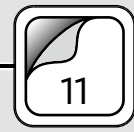
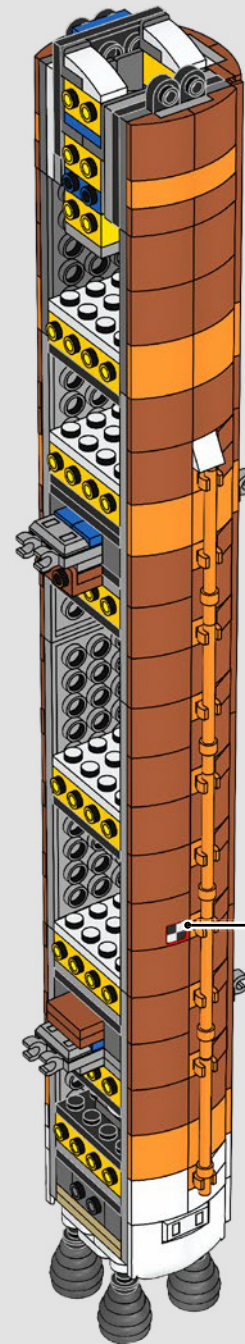

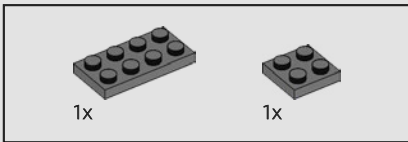
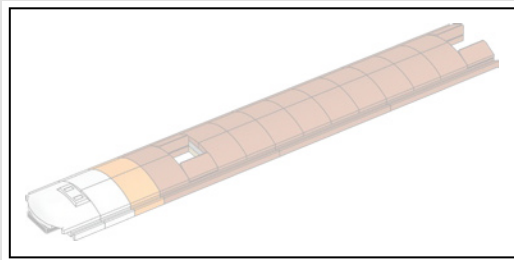

530

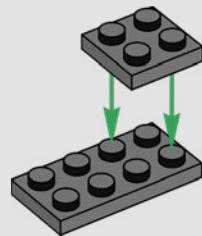

531

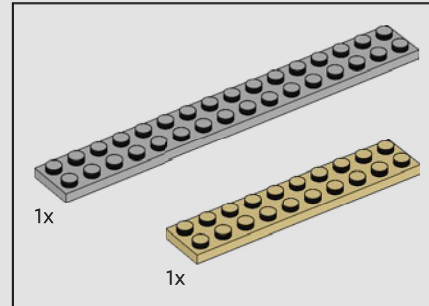
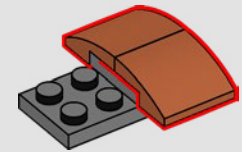

532

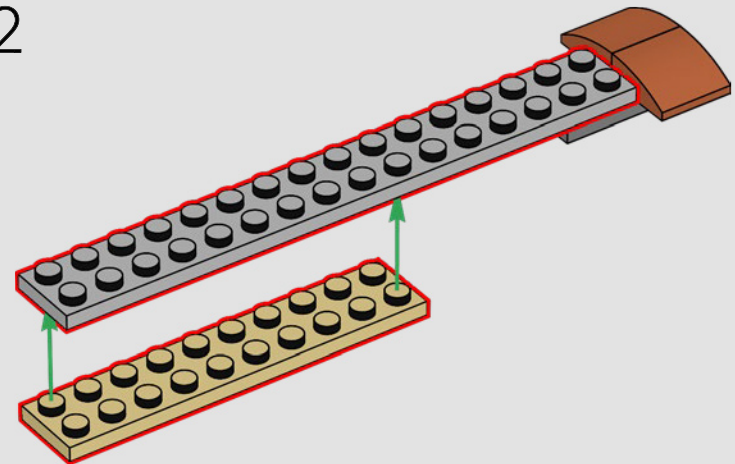



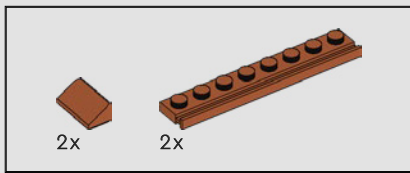

533

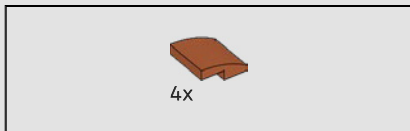
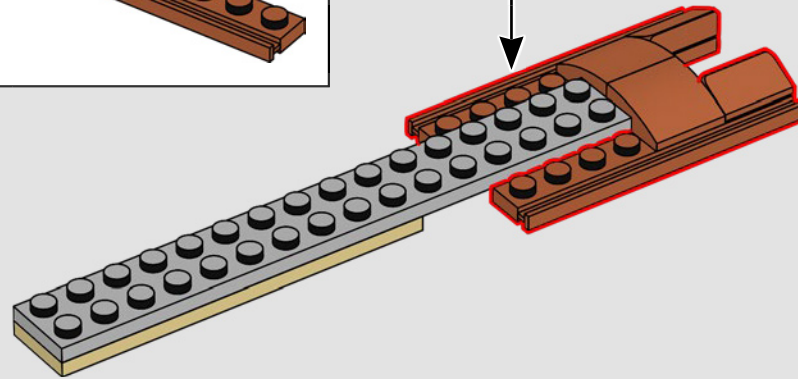
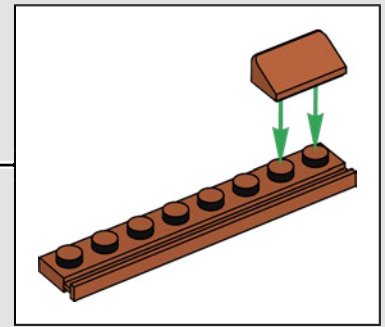
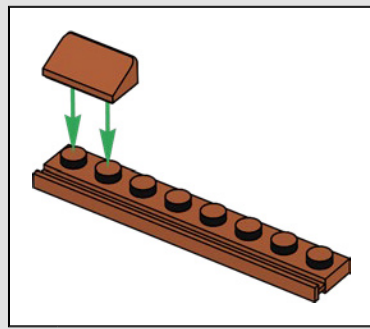

534

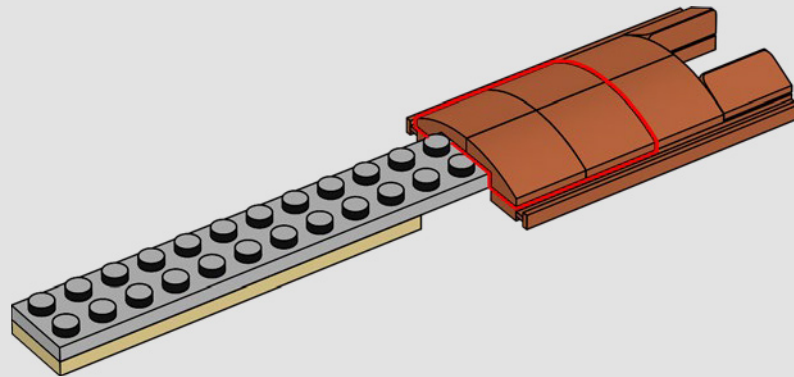

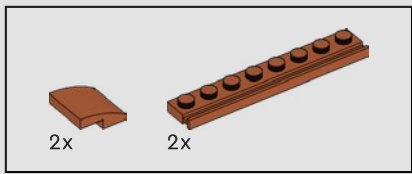

535

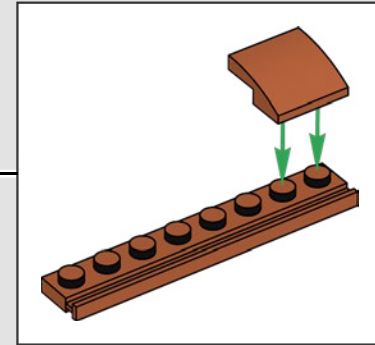
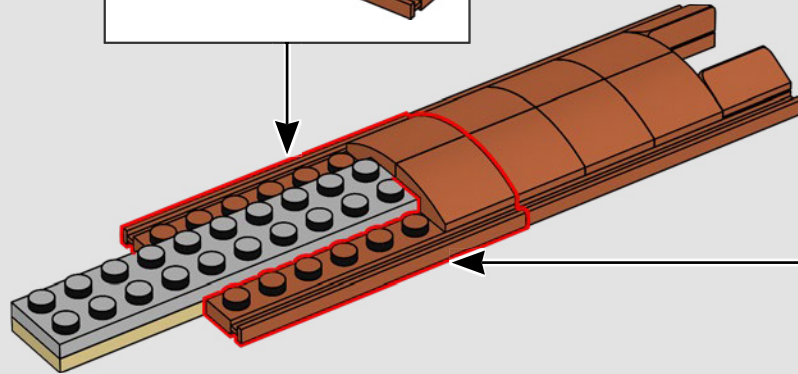
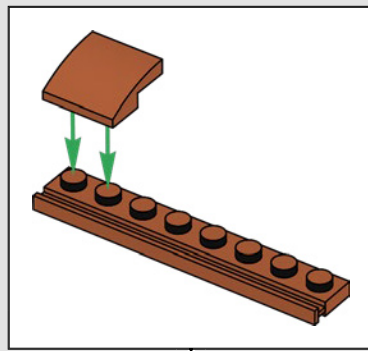

536

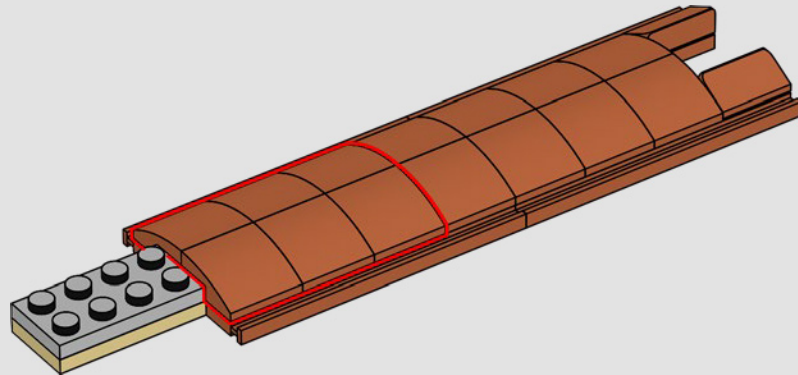

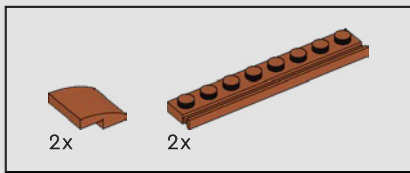

537

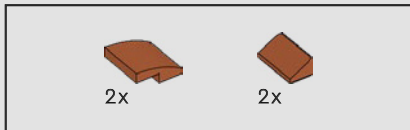
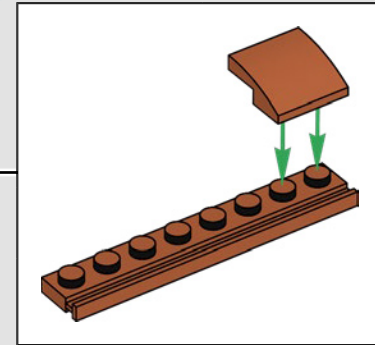
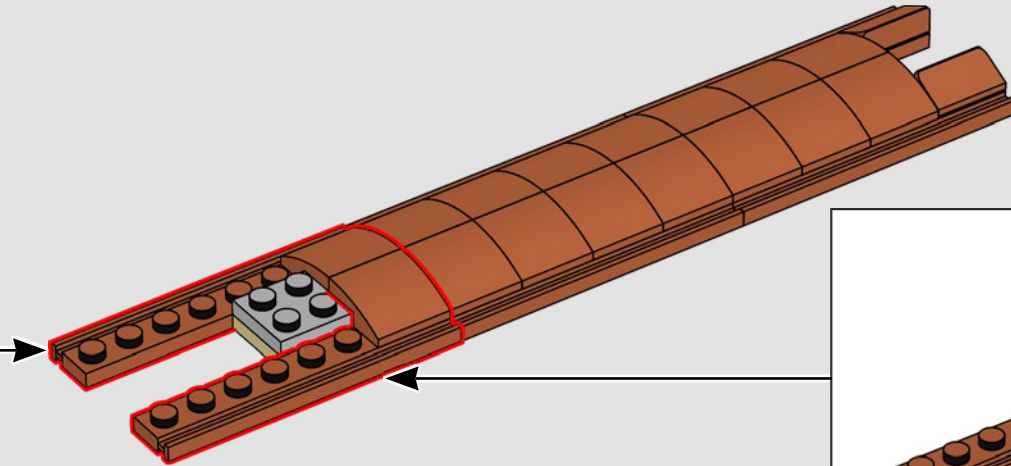
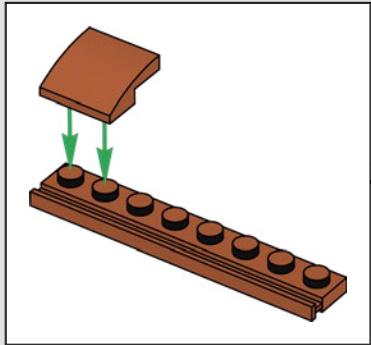

538

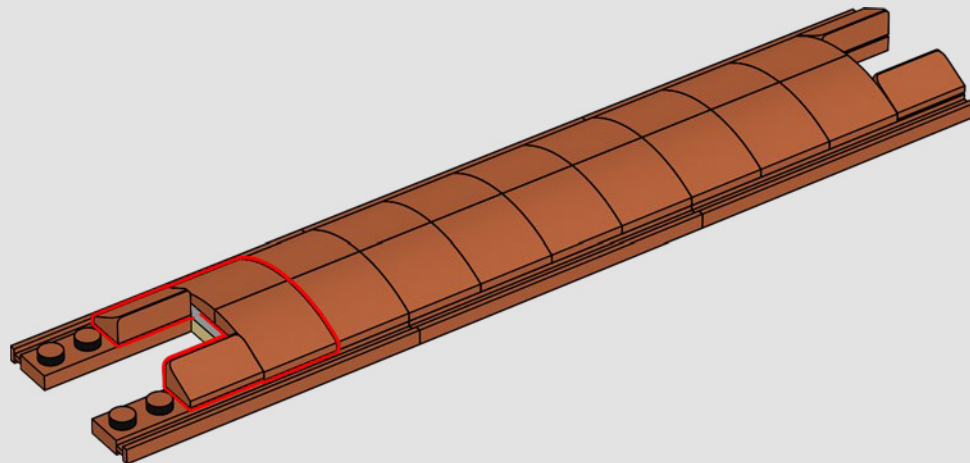

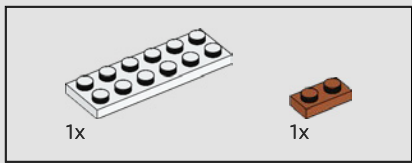

539

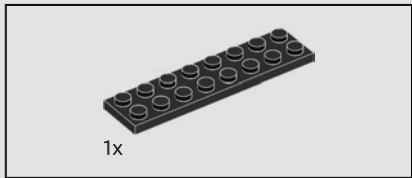
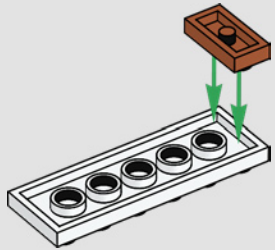

540

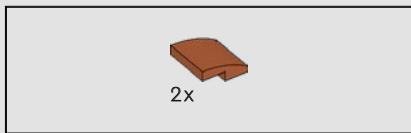
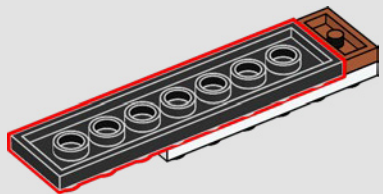

541

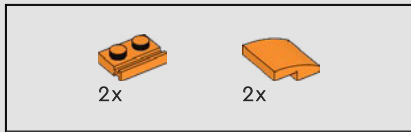
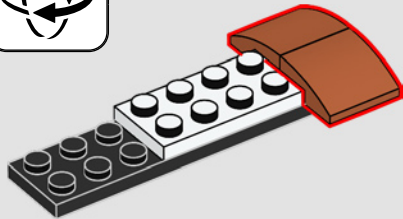
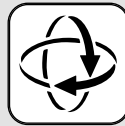

542

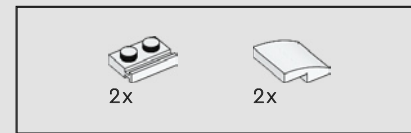
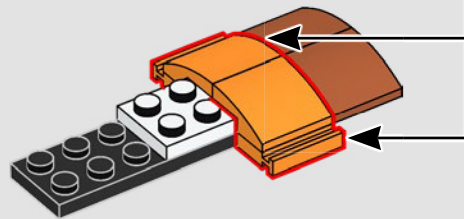
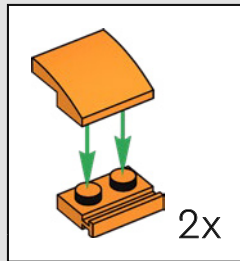

543

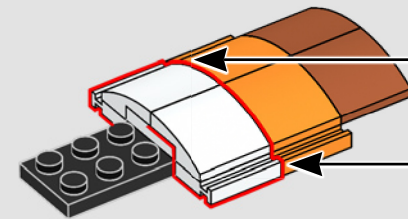
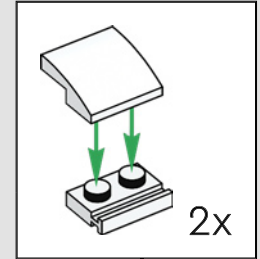

544

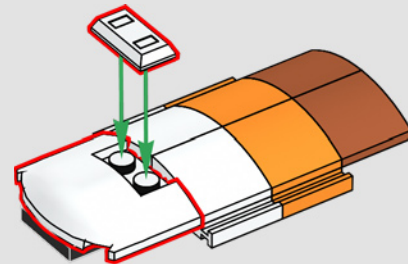

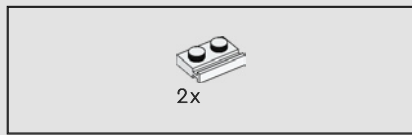

545

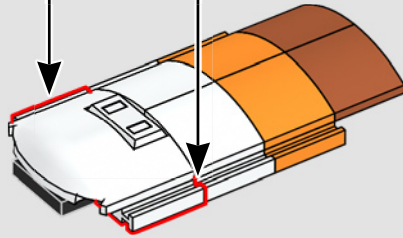
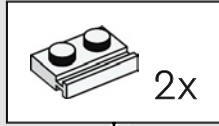

546

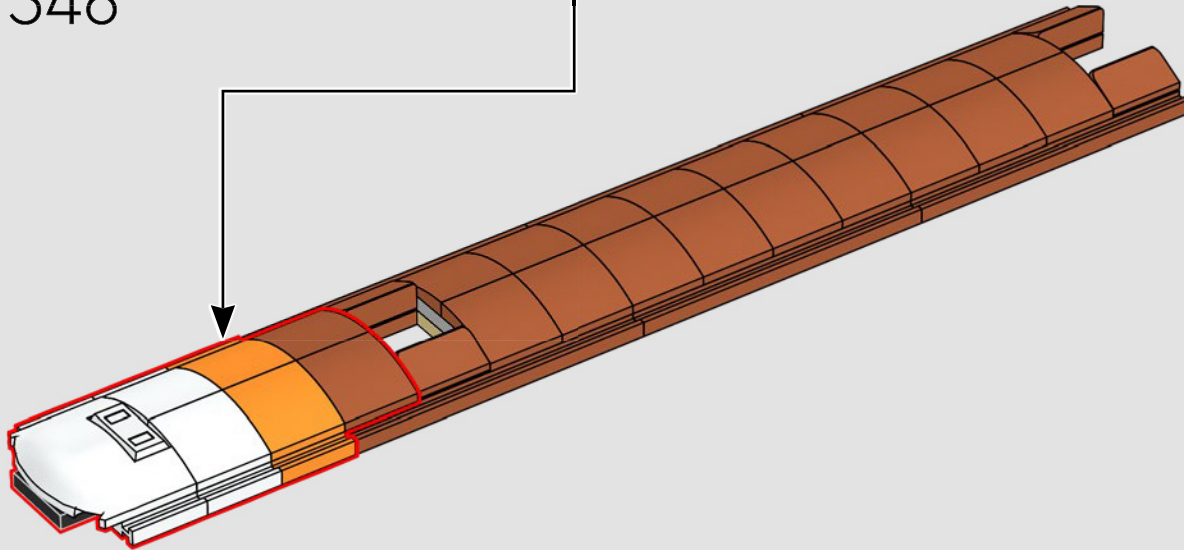

547

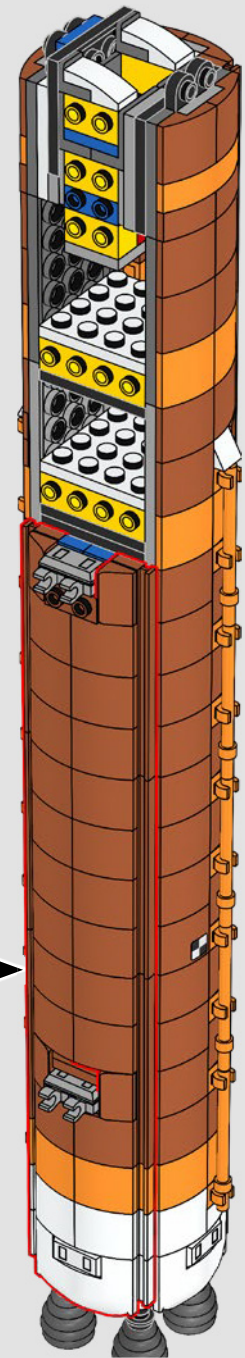

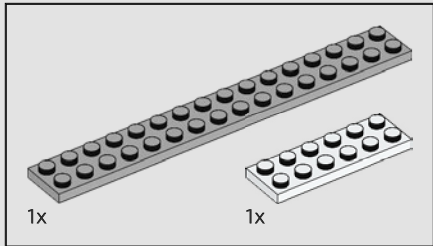
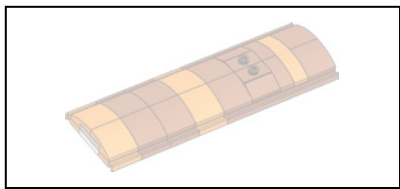

548

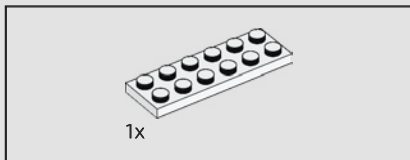
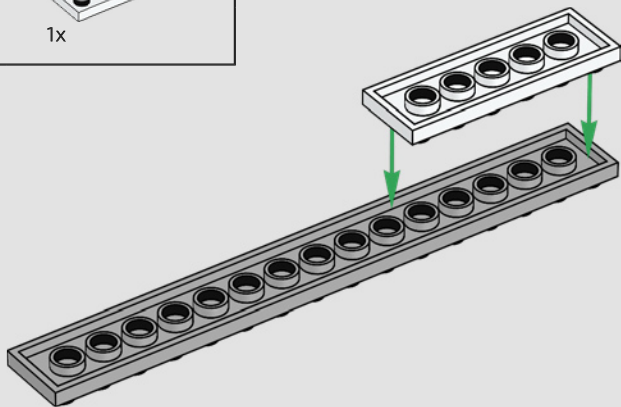

549

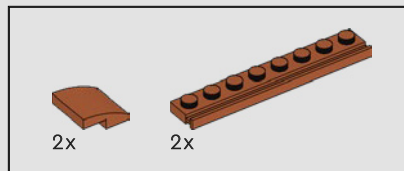
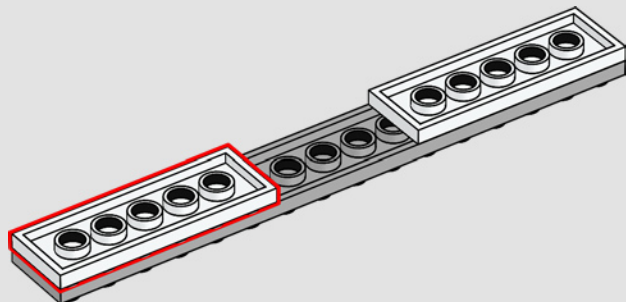

550

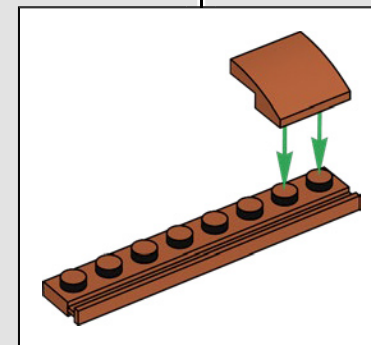
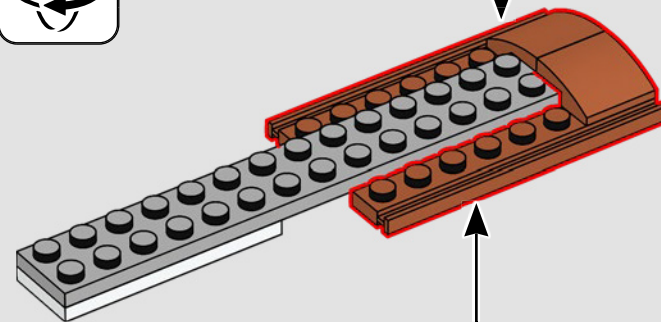
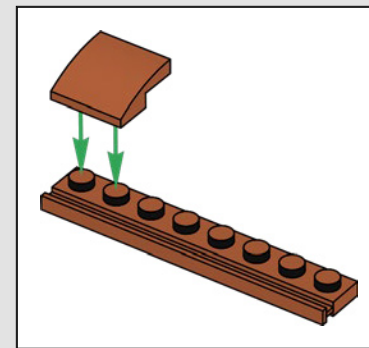
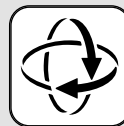

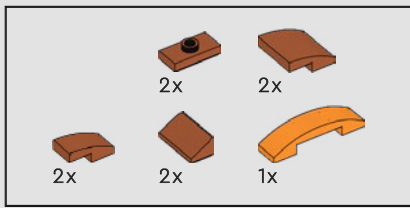

551

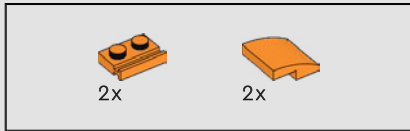
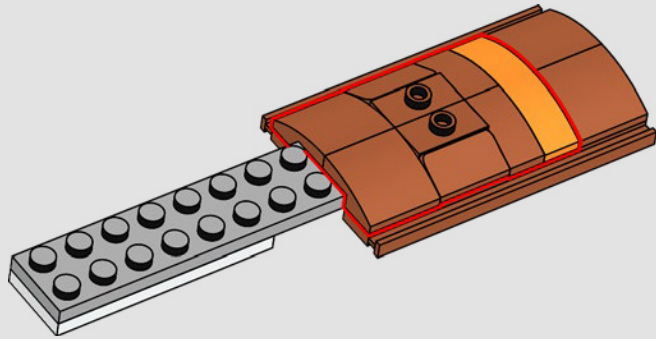

552

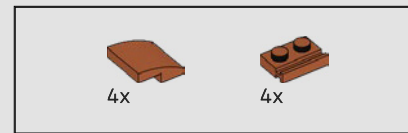
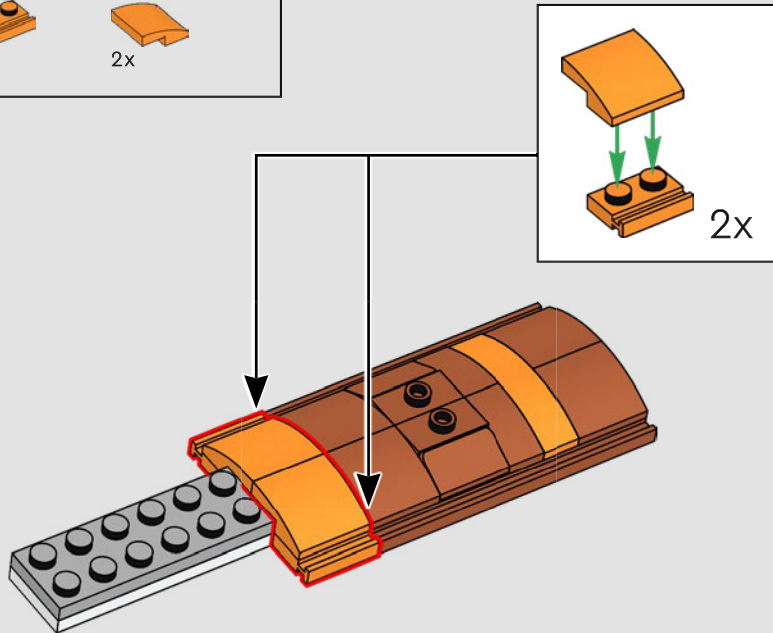

553

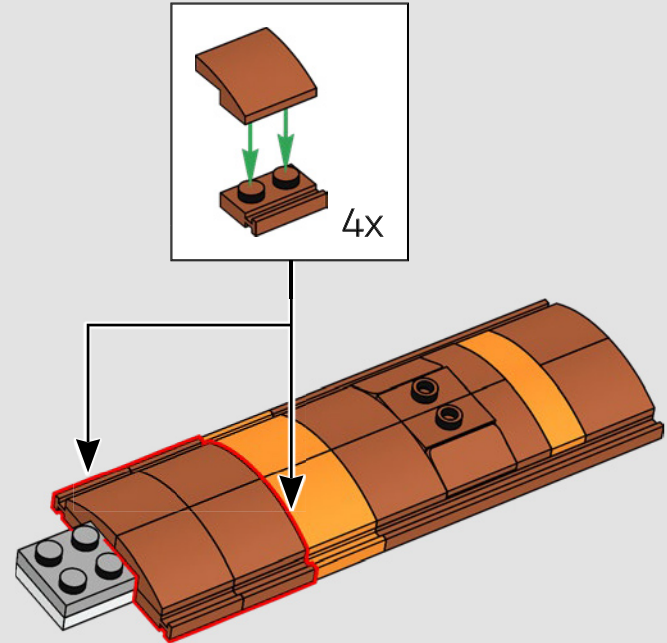

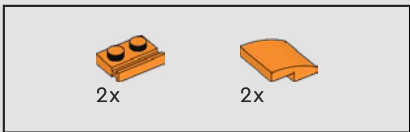

554

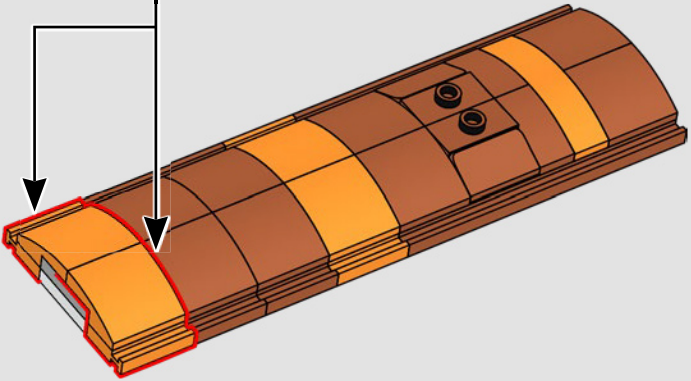
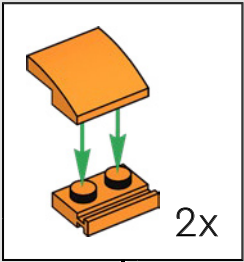

555

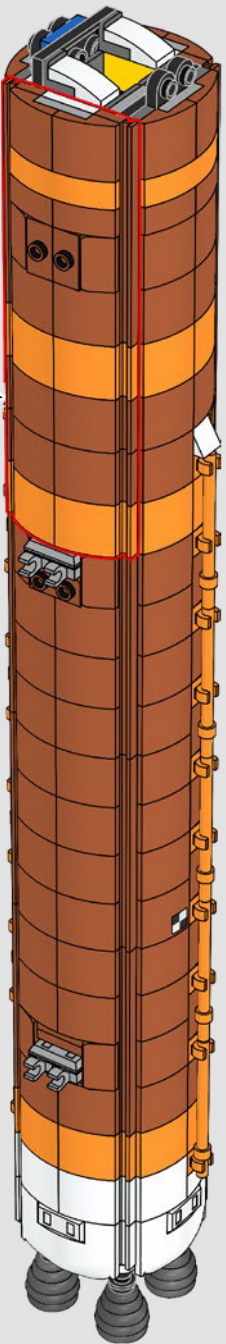



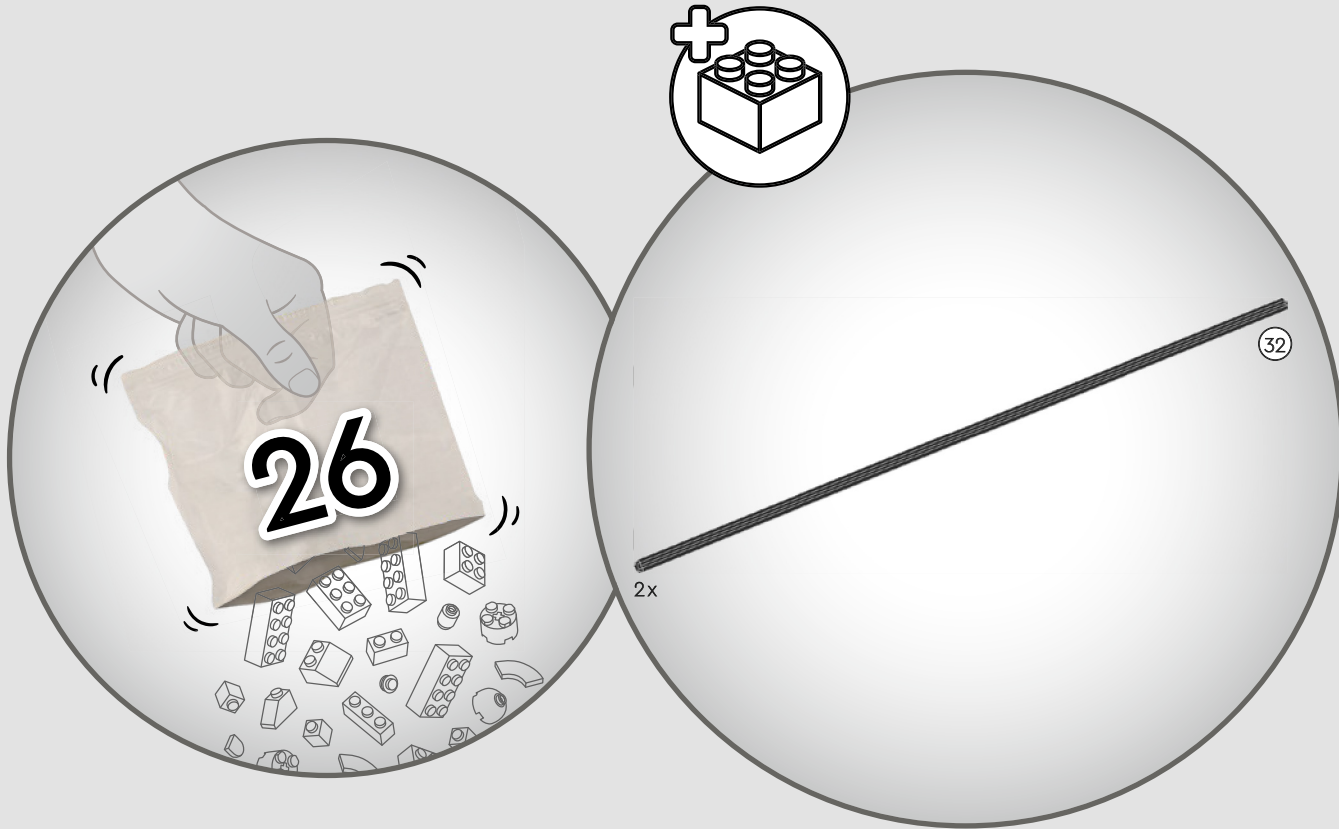

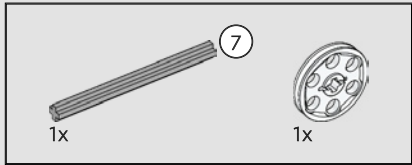
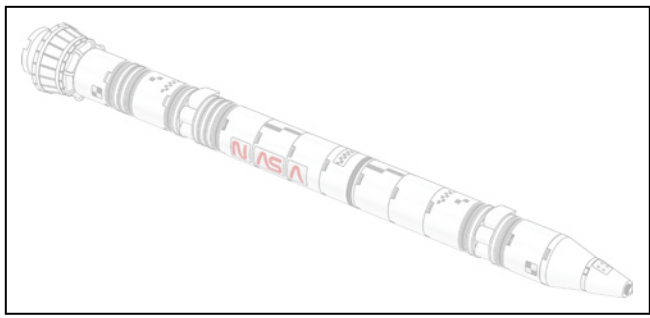

556

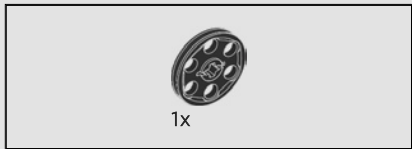
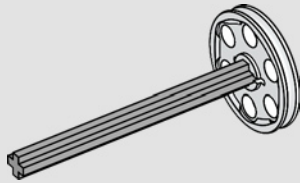

557

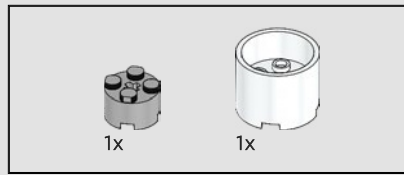
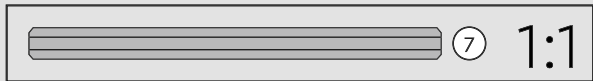
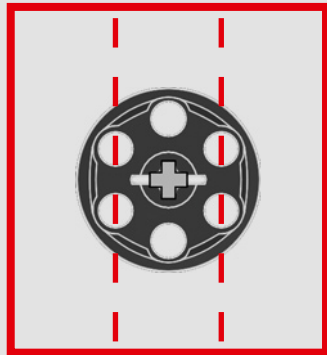
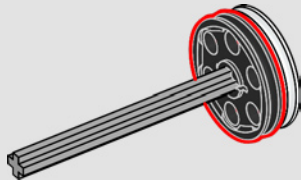

558

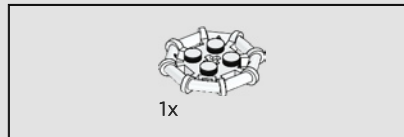
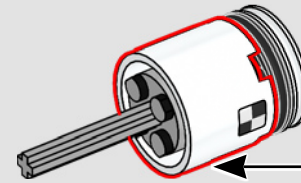
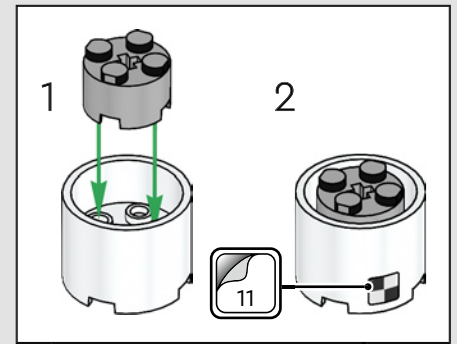

559

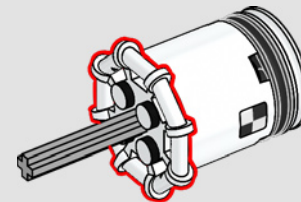

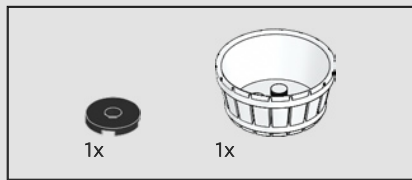

560

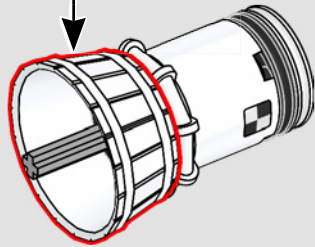
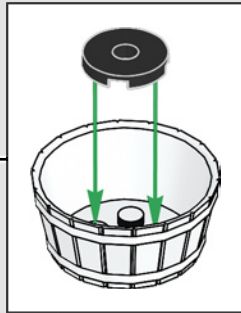

562

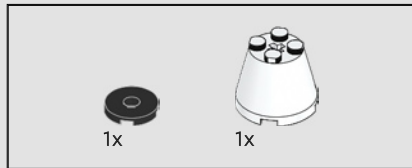
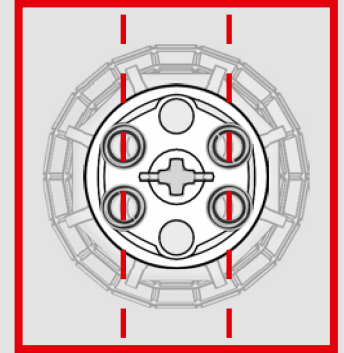
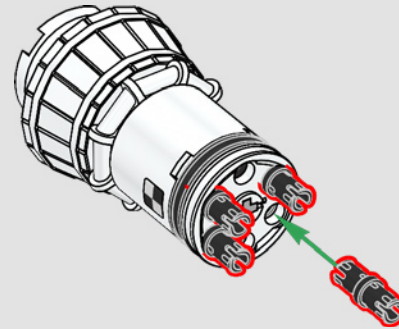

561

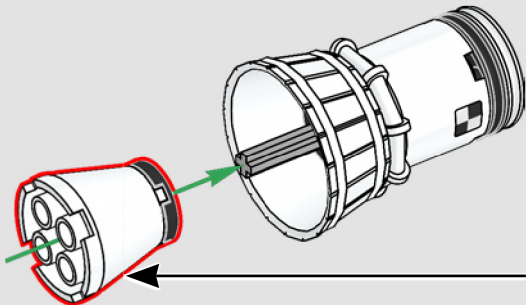
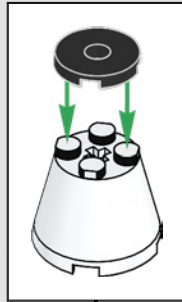

563

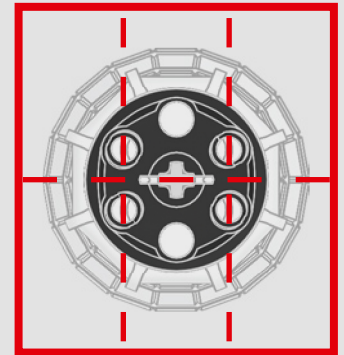
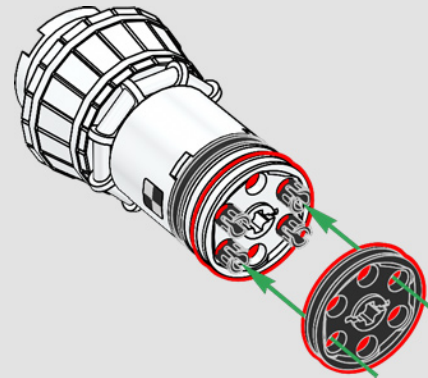

564

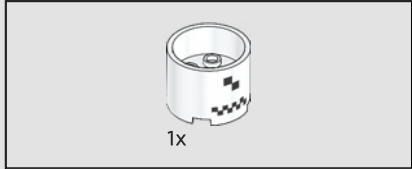
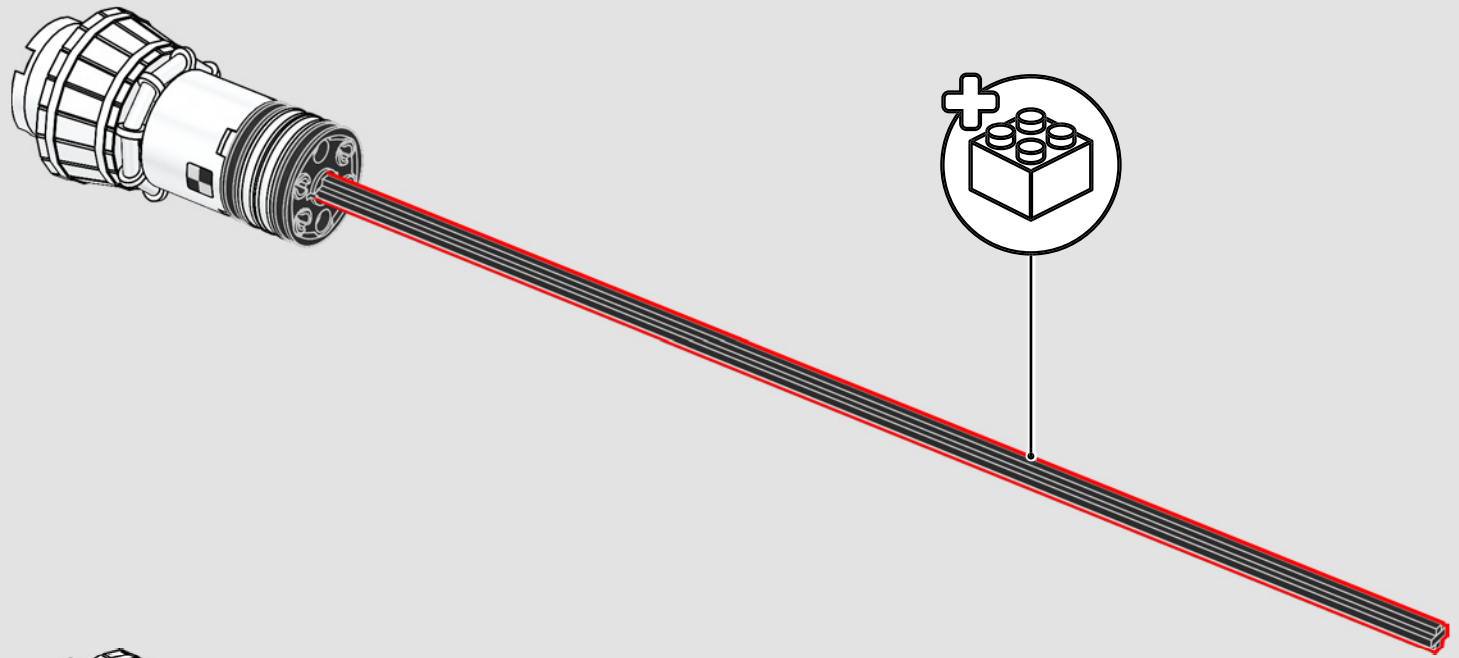

565

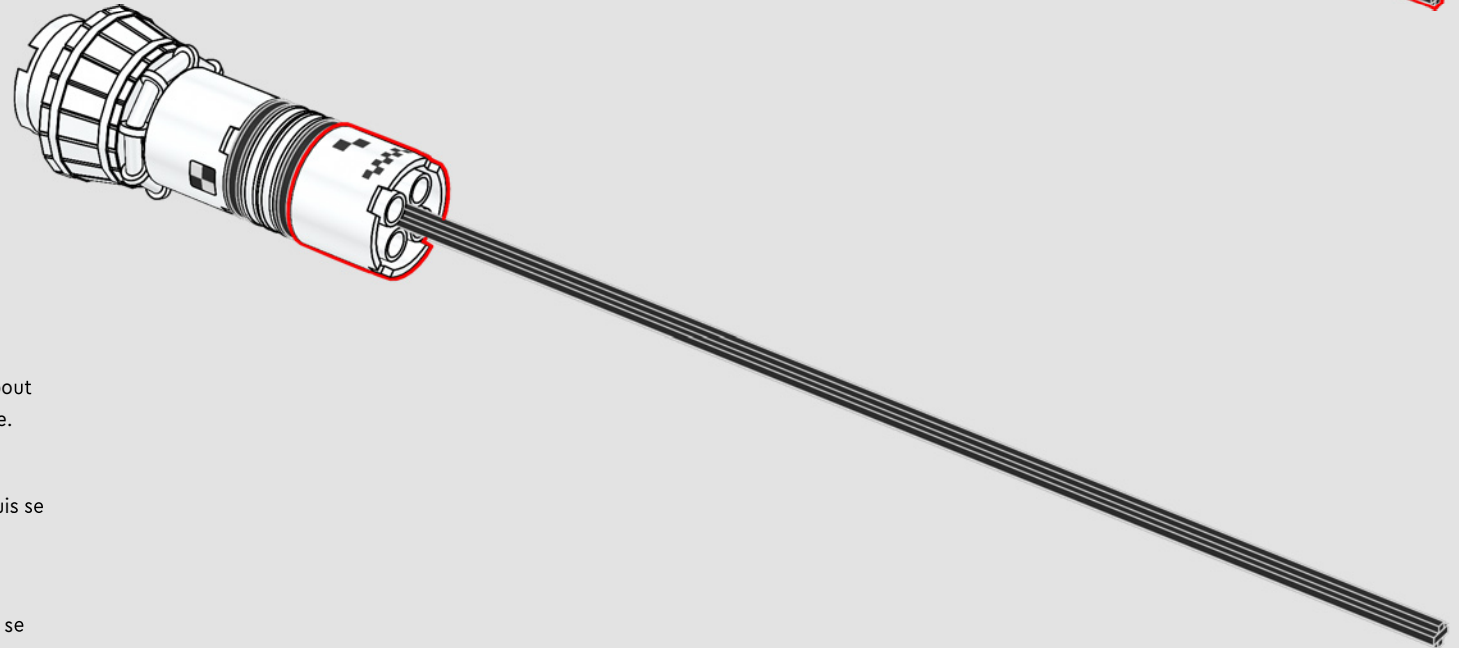

After the SLS launches, boosters operate for about two minutes, then separate from the core stage.

Après le lancement du SLS, les propulseurs fonctionnent pendant environ deux minutes, puis se séparent de l'étage principal.

Luego del lanzamiento del SLS, los propulsores funcionan durante unos dos minutos y después se separan de la etapa central.

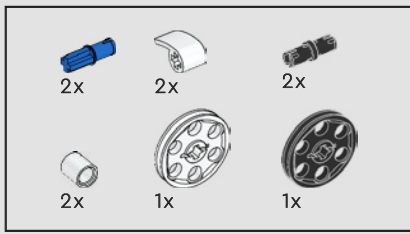

566

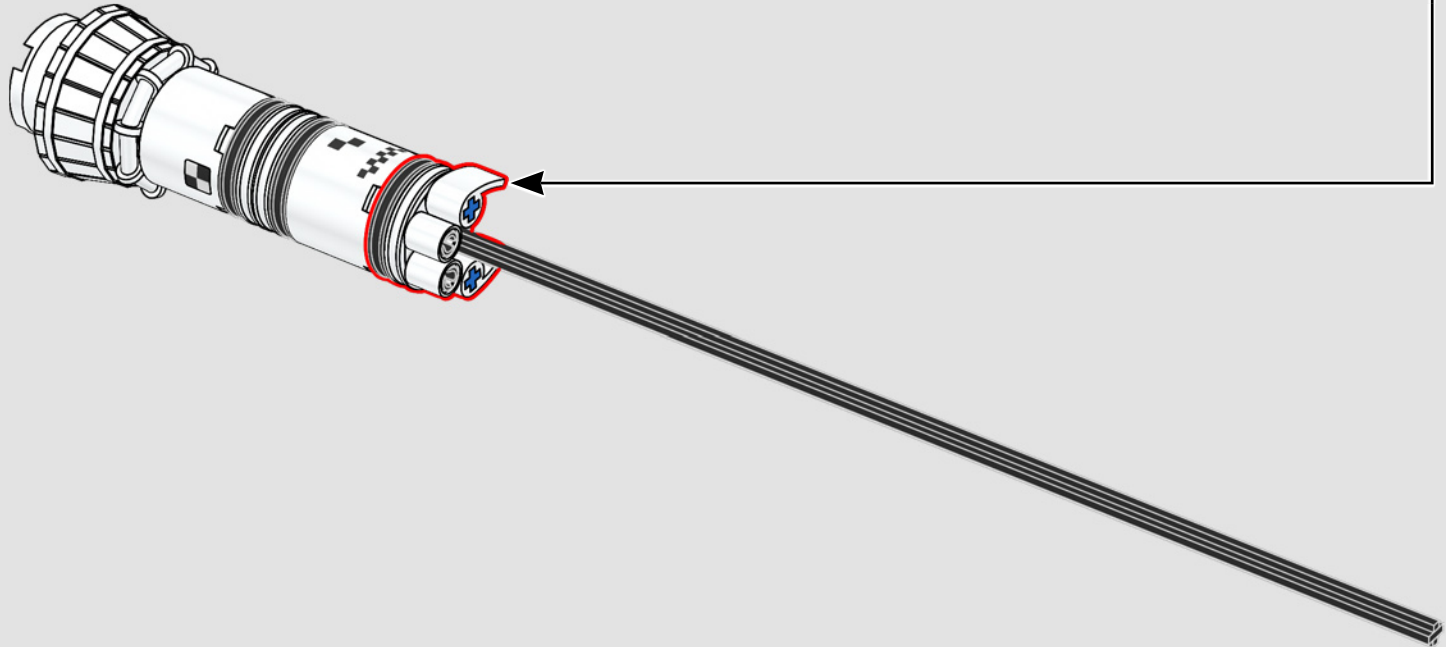
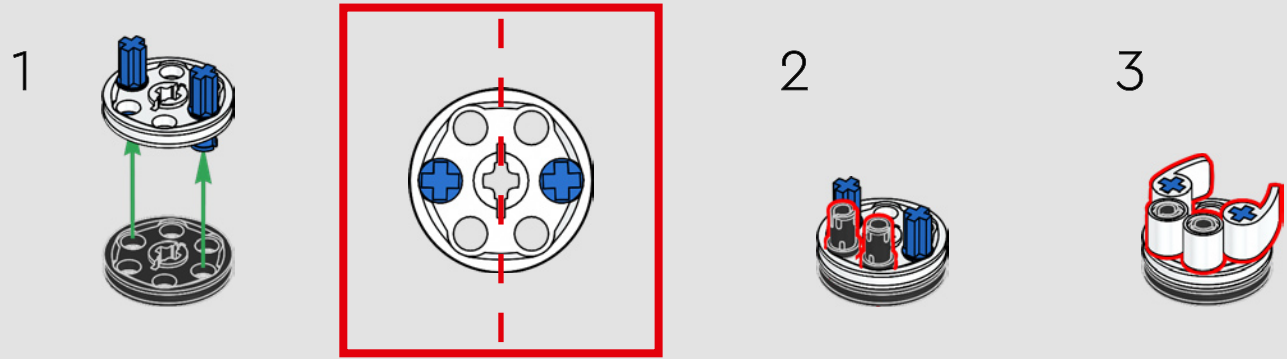



1x

567

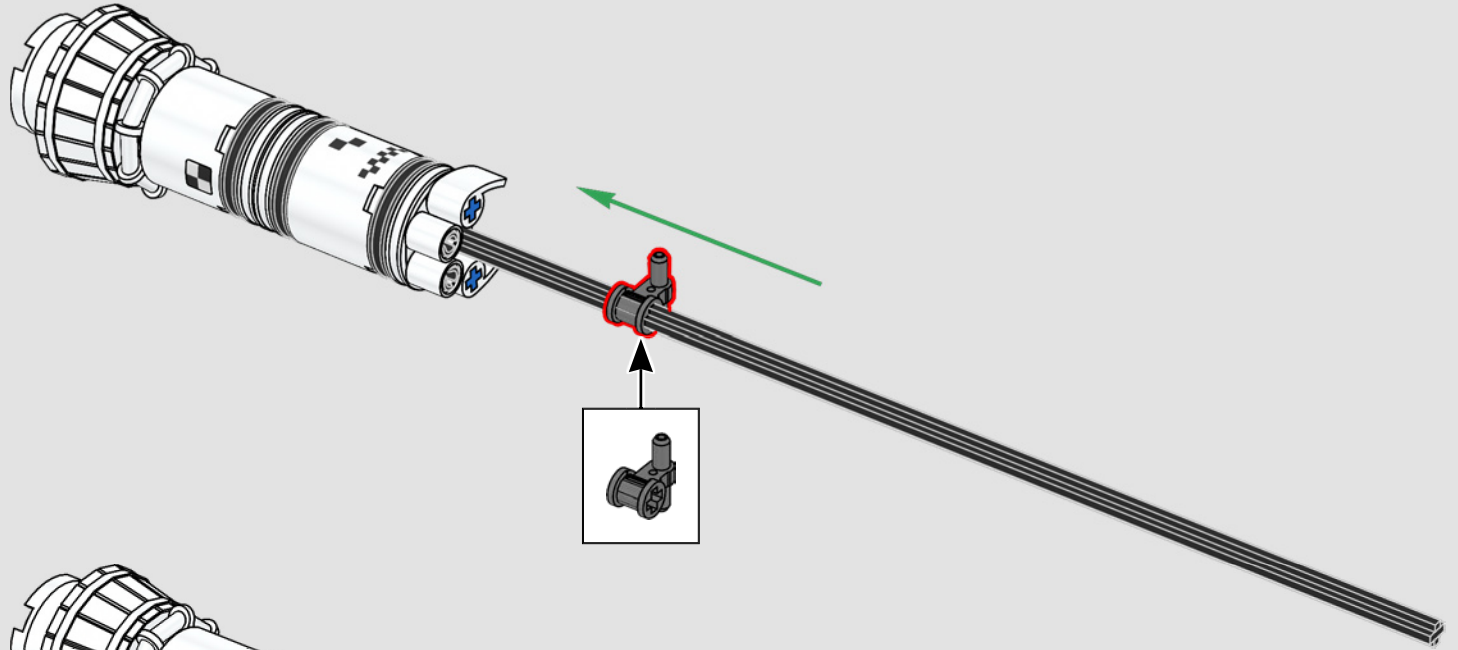

1x



3x

568

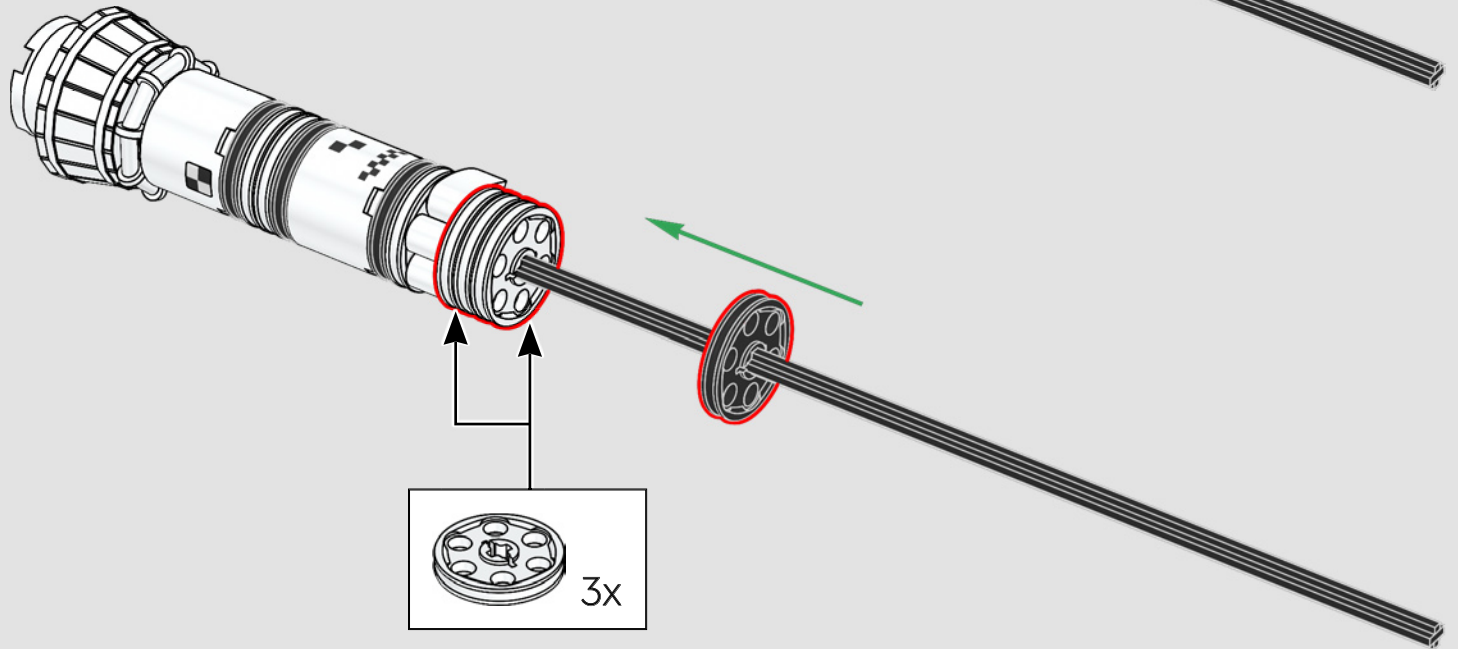

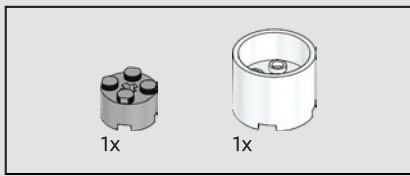

569

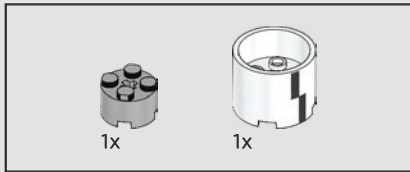
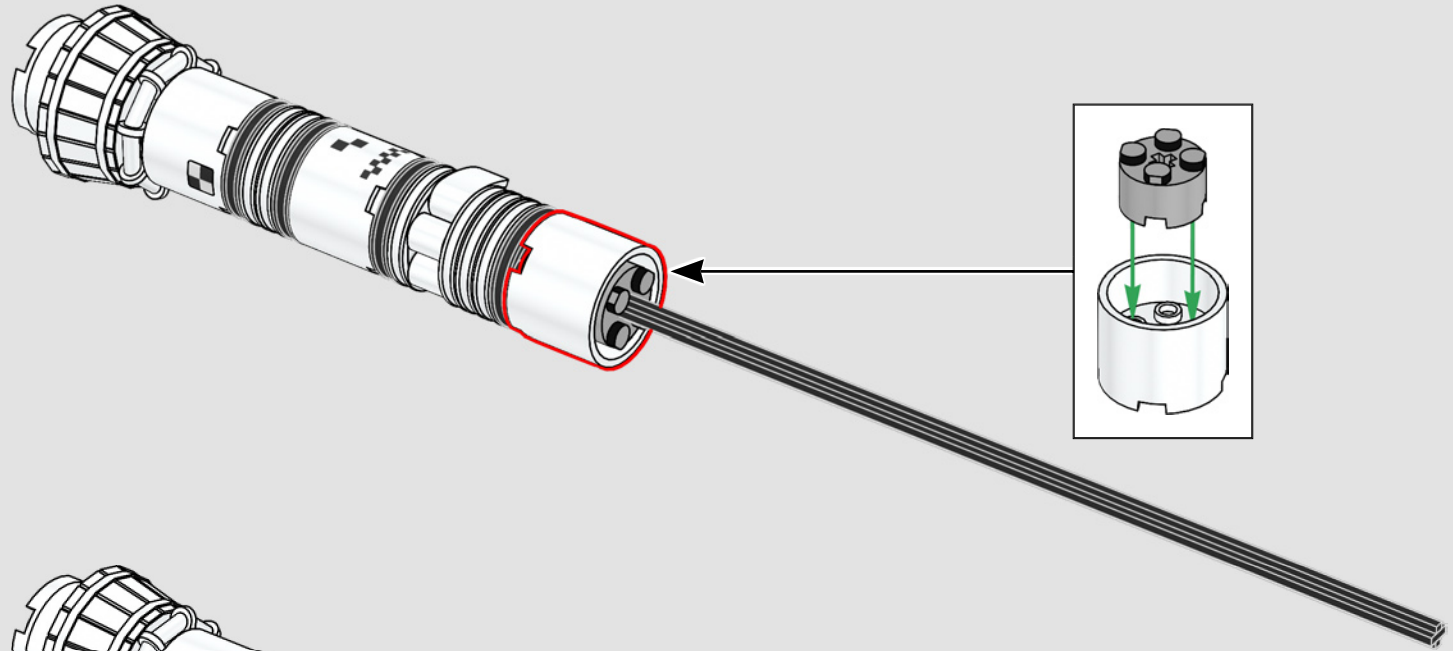

570

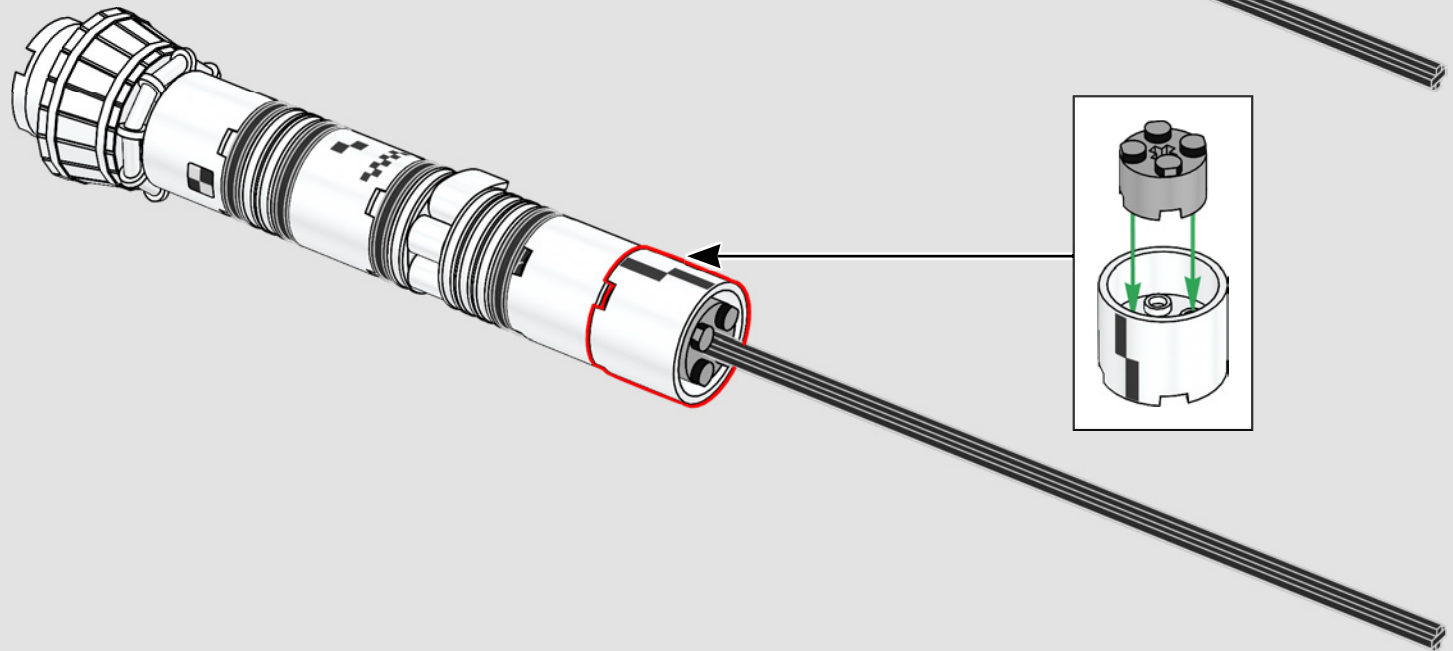

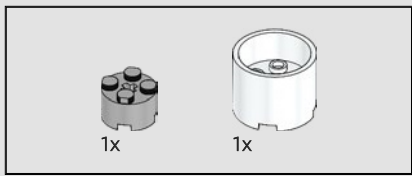

571

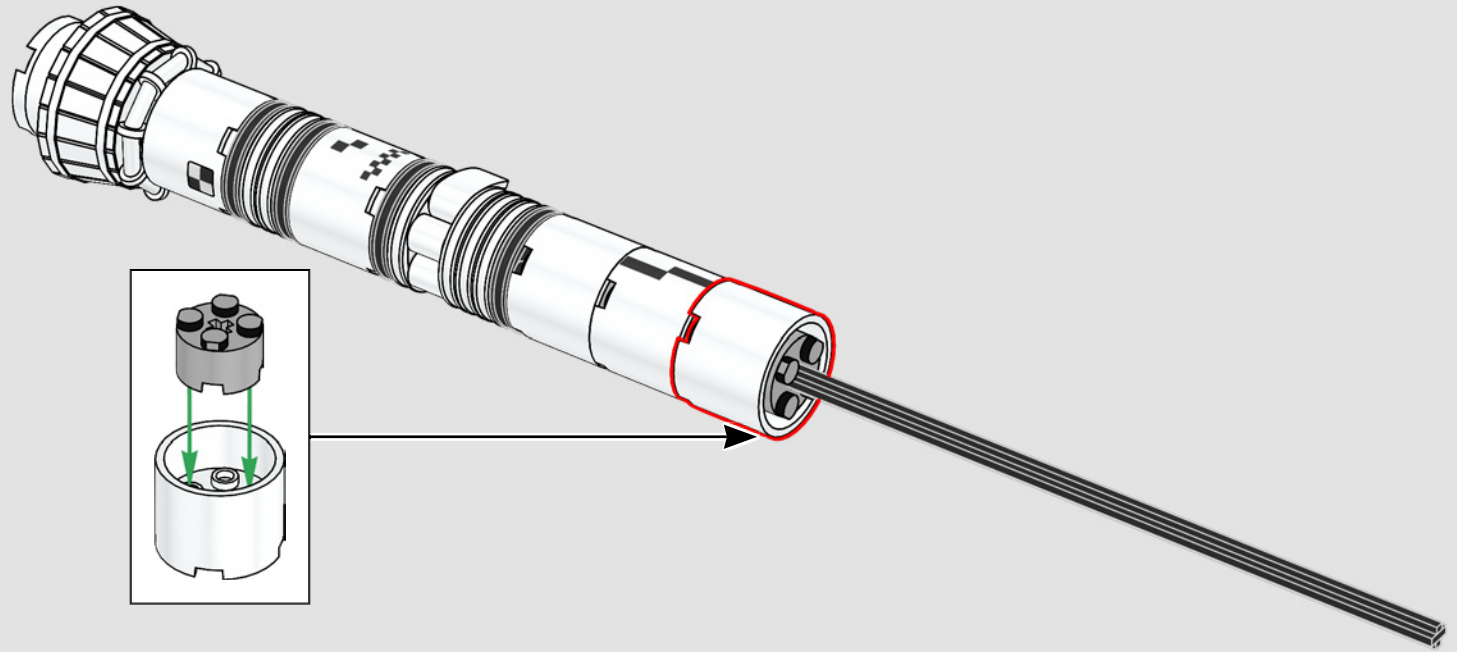

572

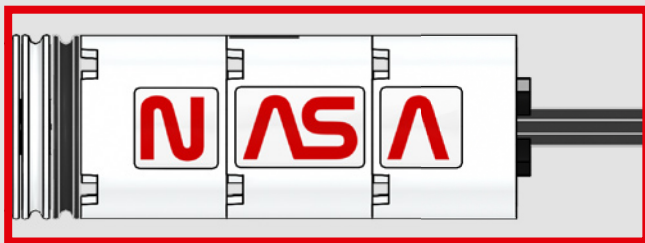
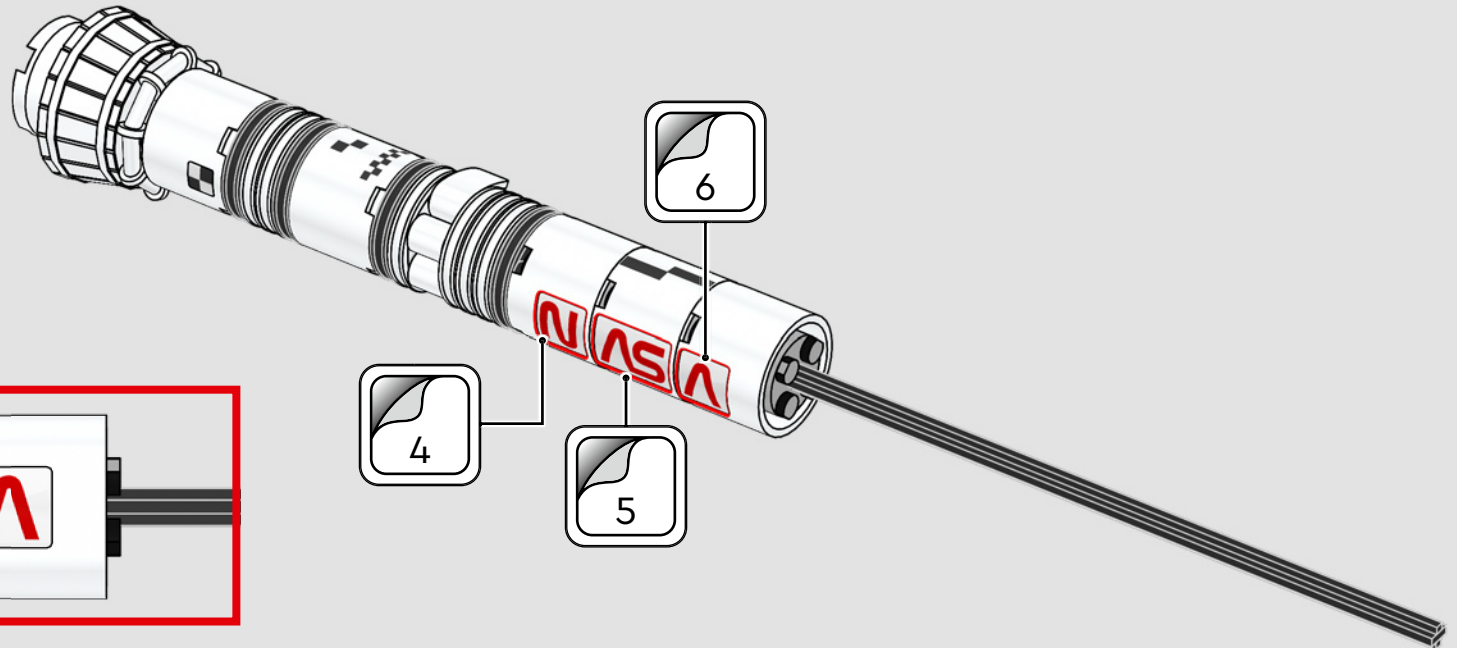



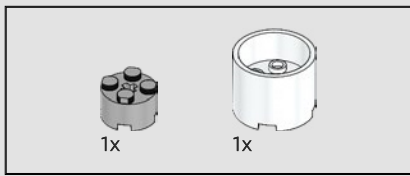

573

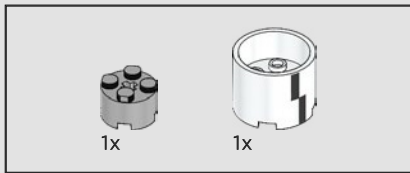
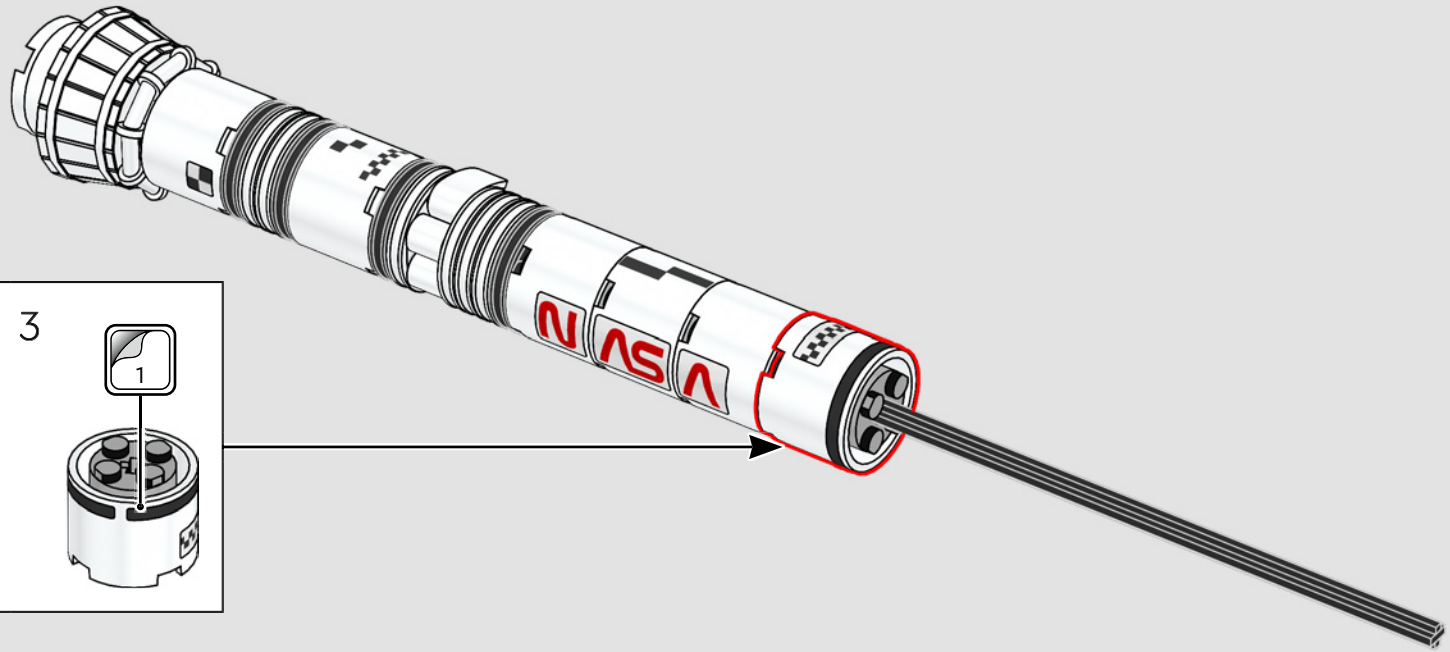
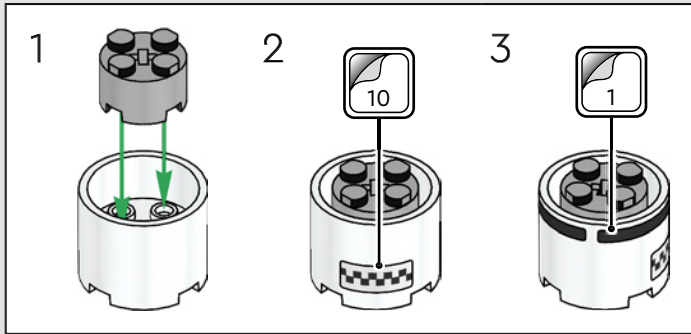

574

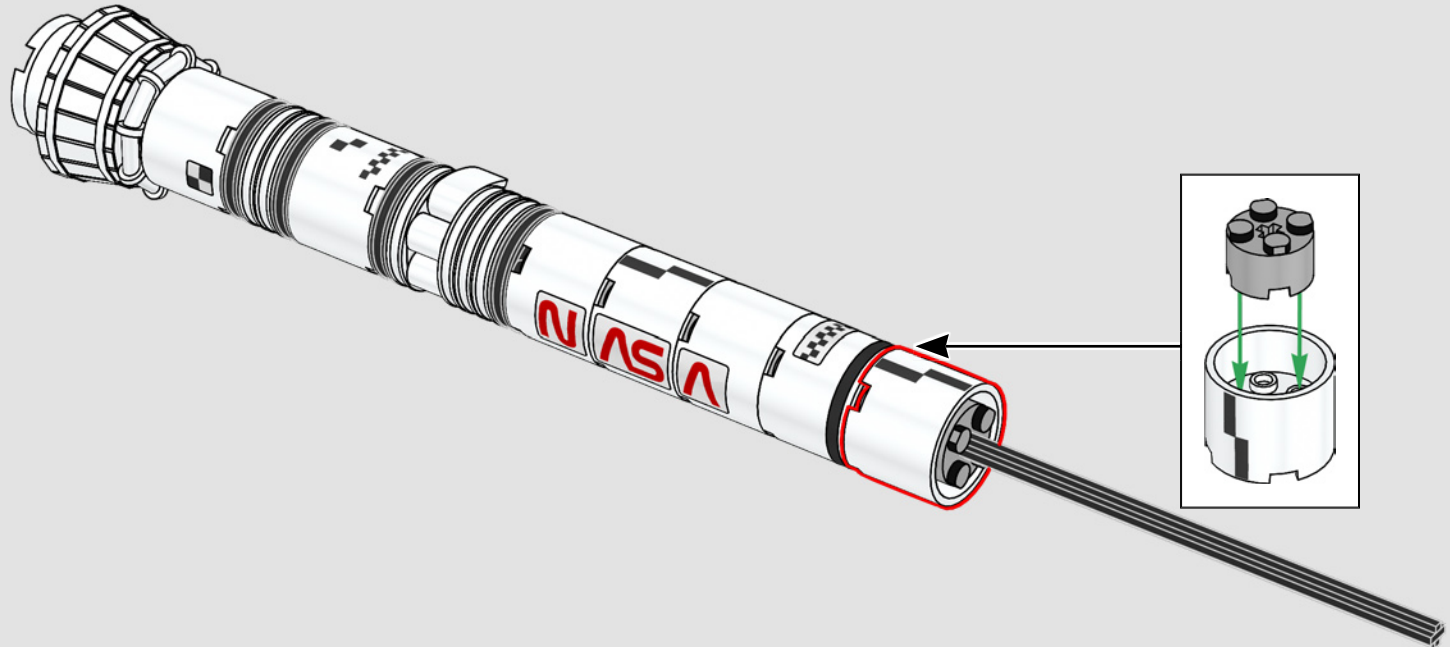

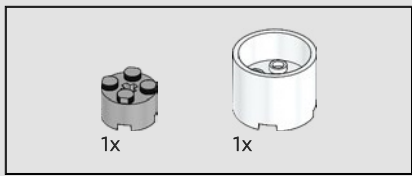

575

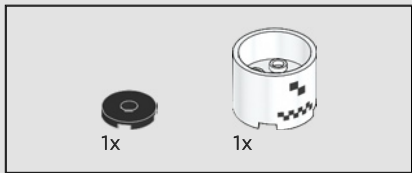
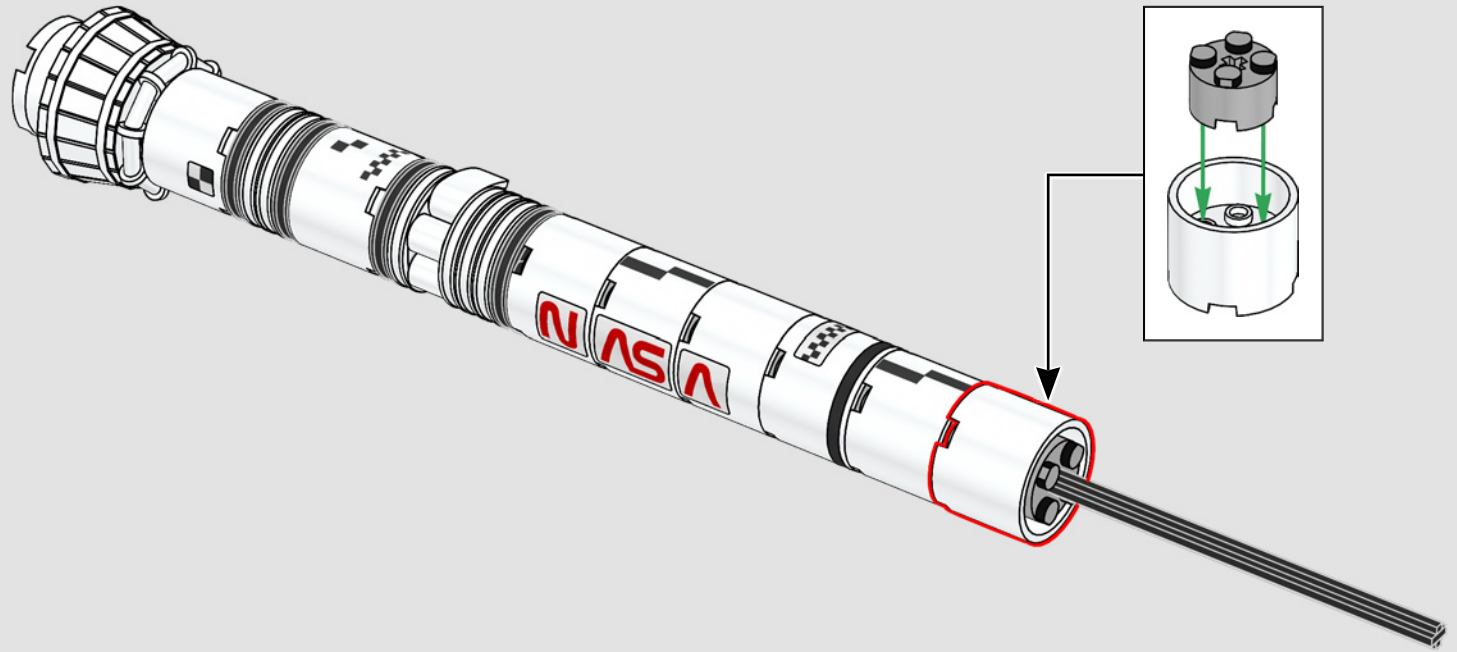

576

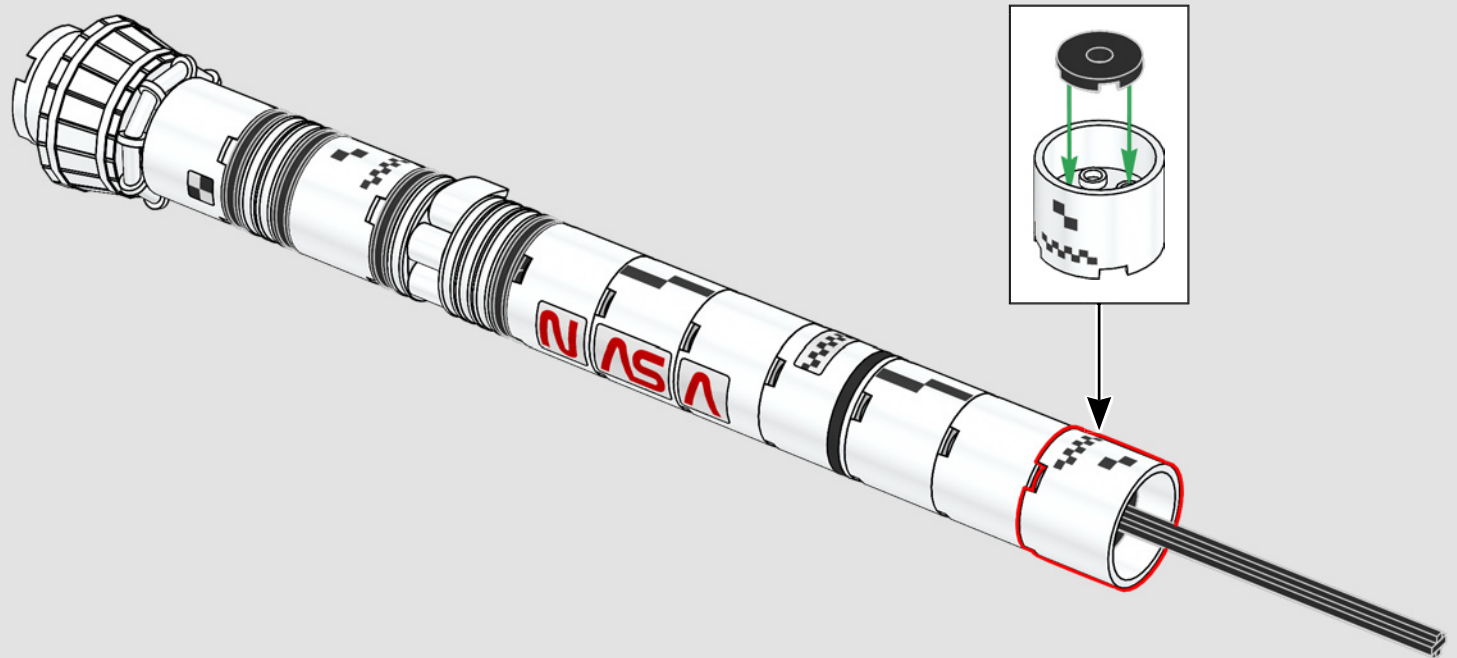

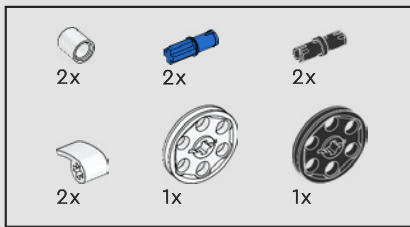

577

1

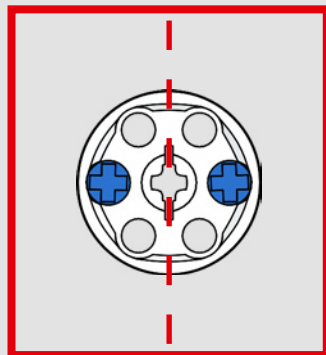
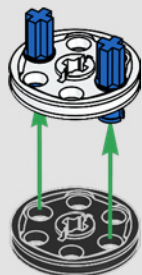

2

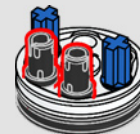

3

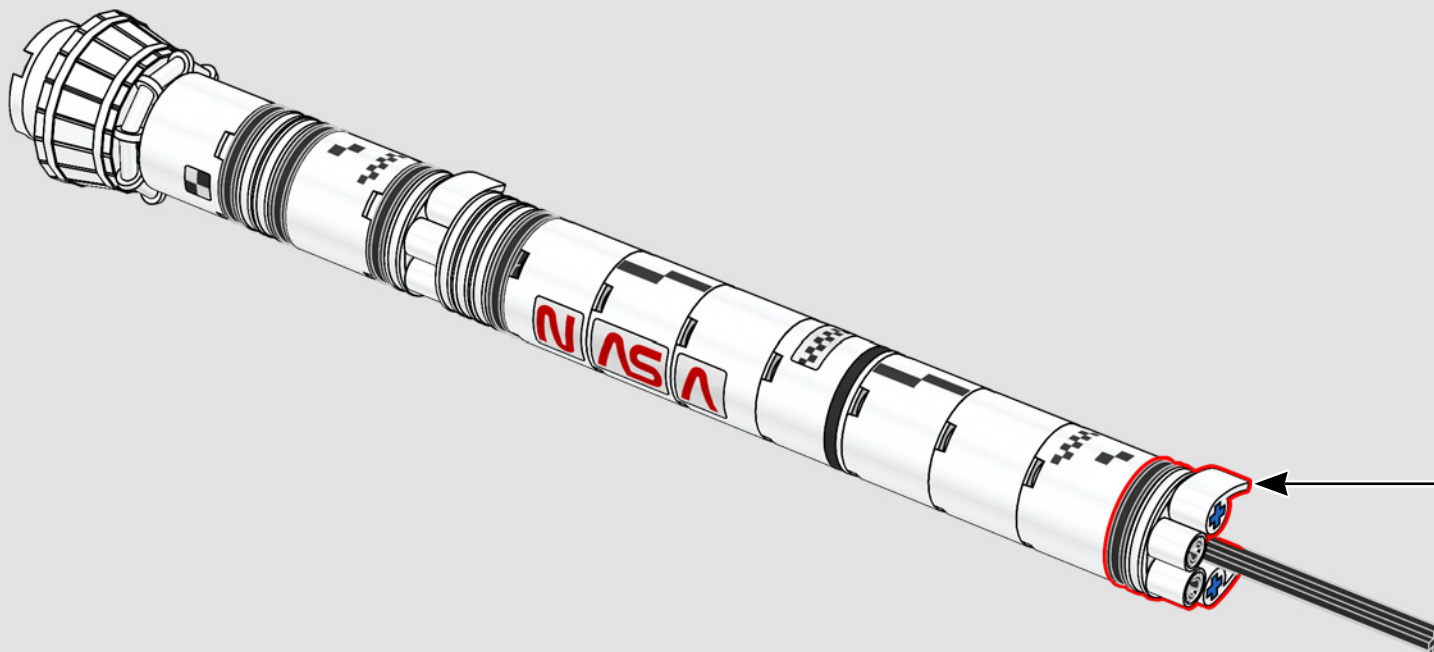



1x

578

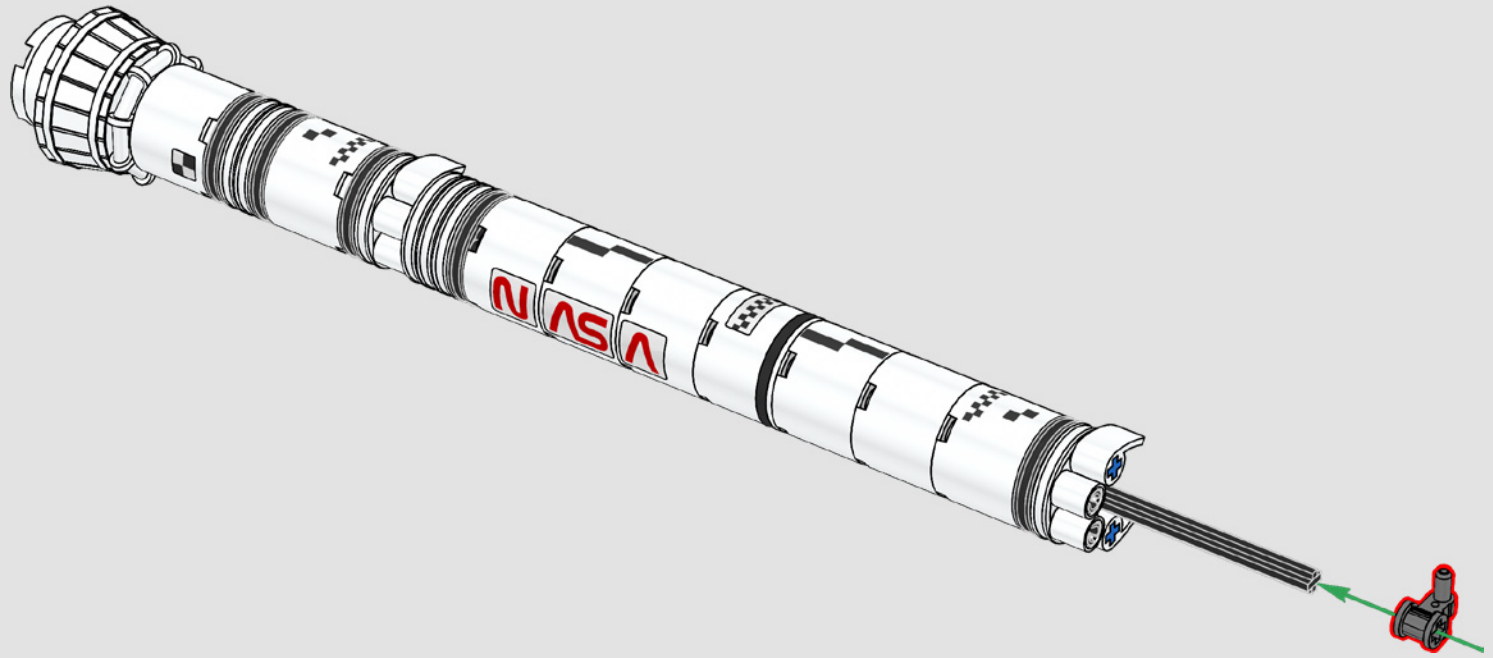

1x



1x

579

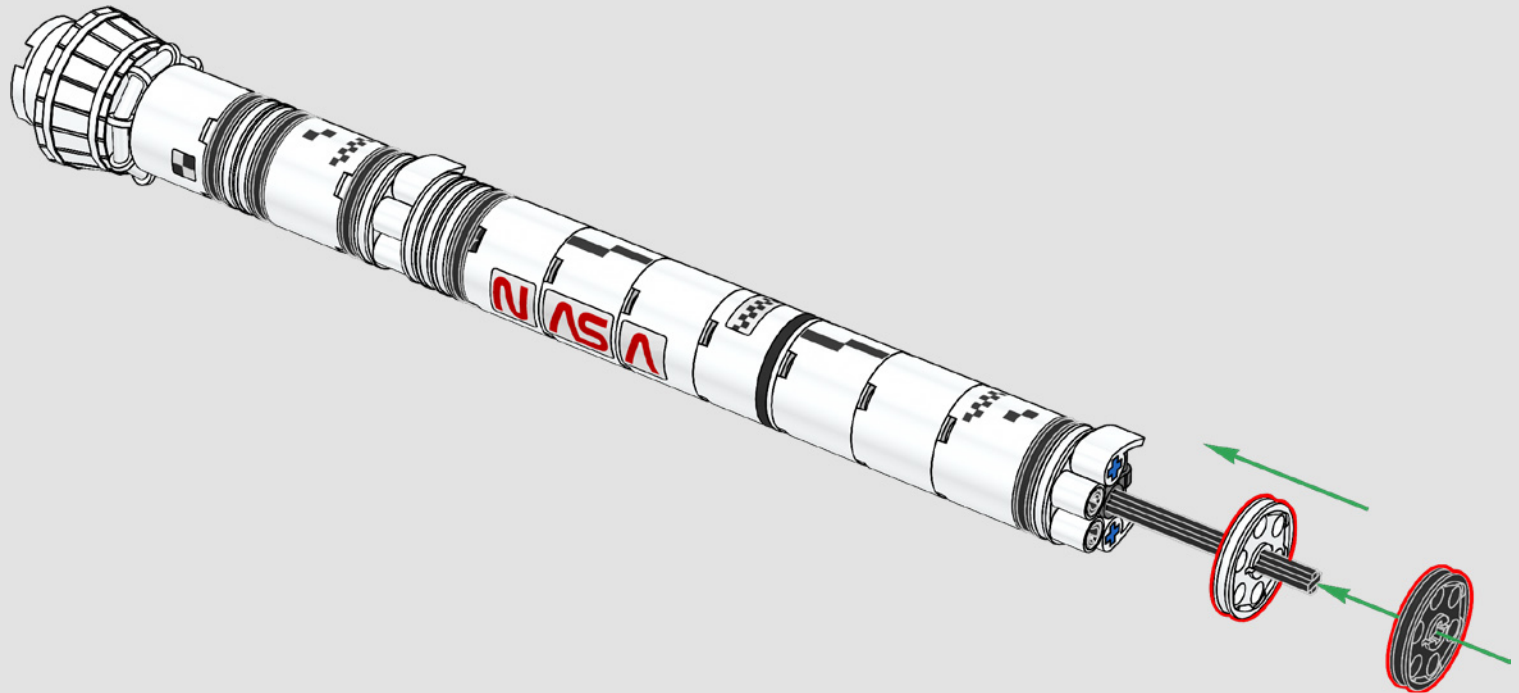

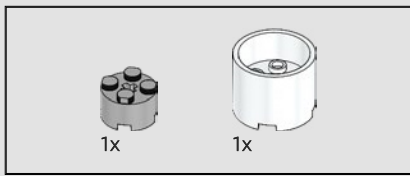

580

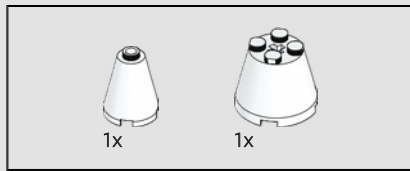
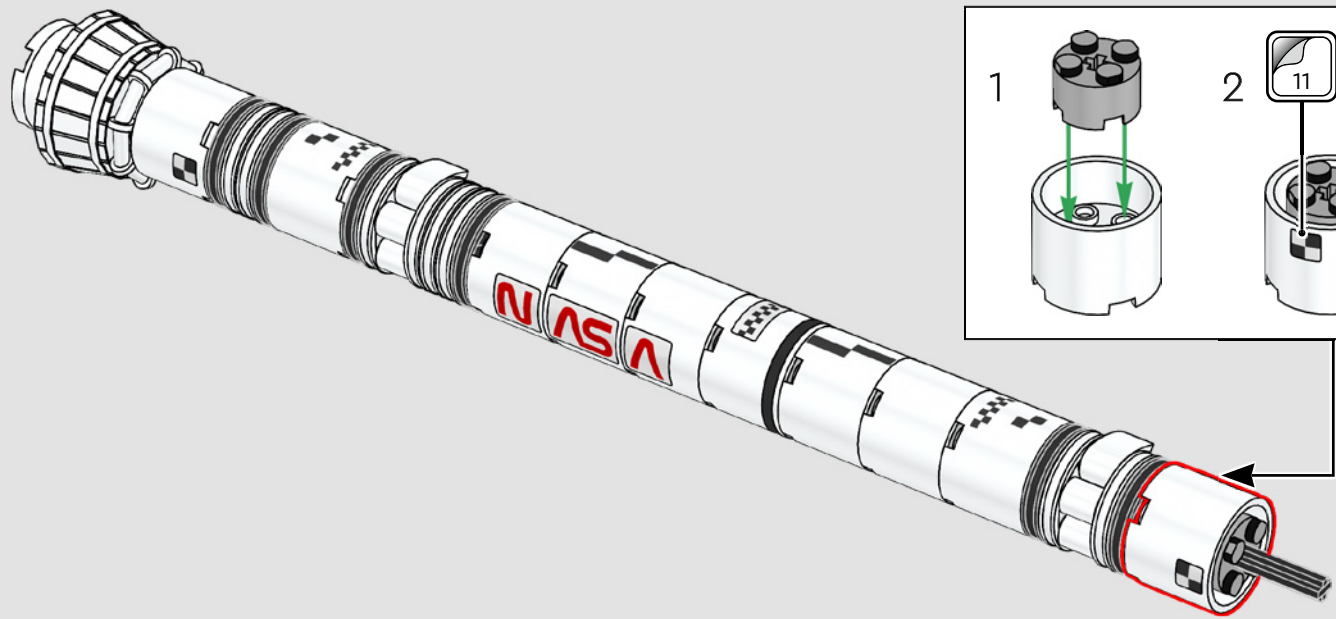

581

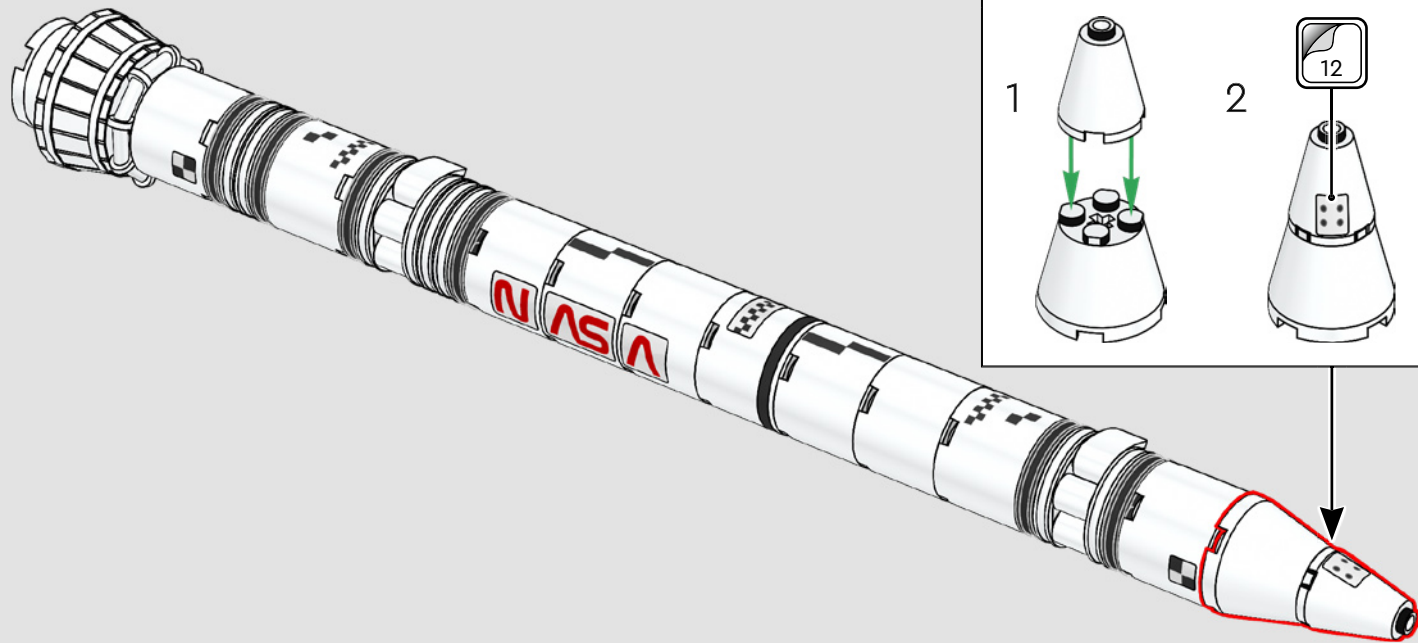

582

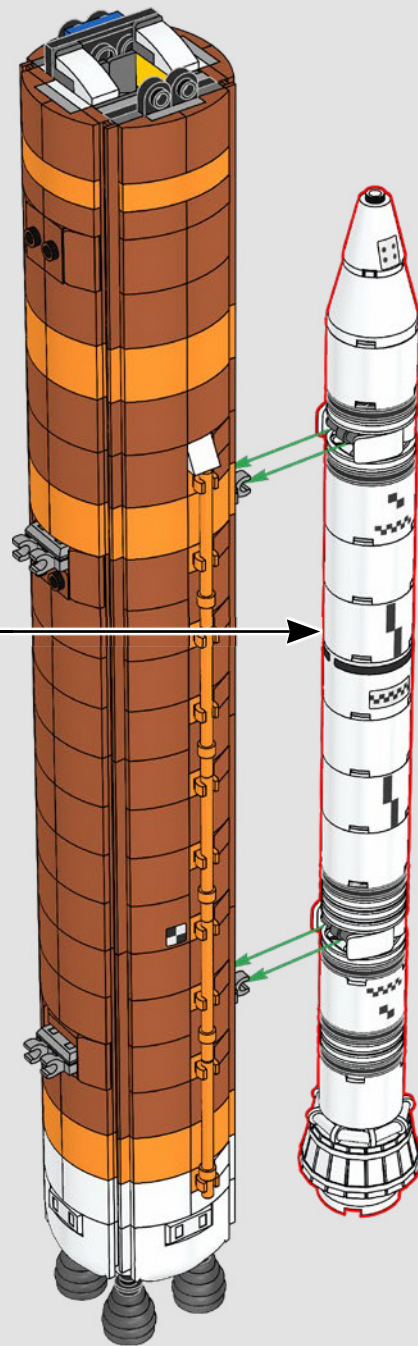

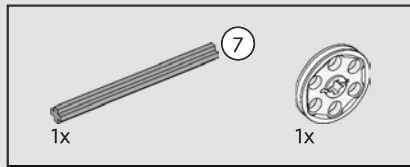
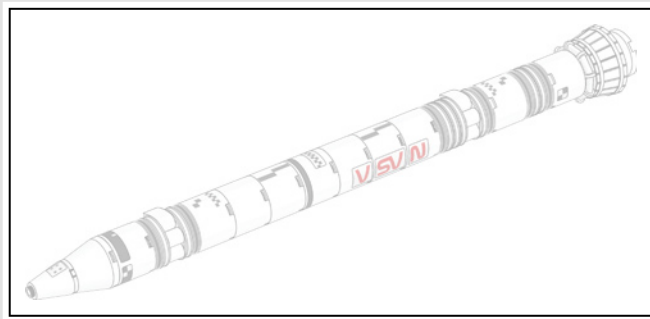

583

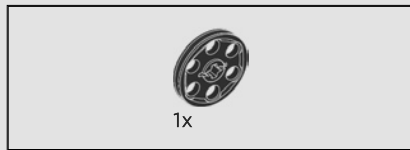
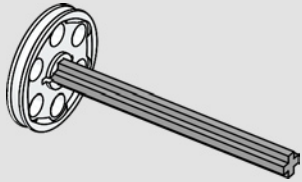

584

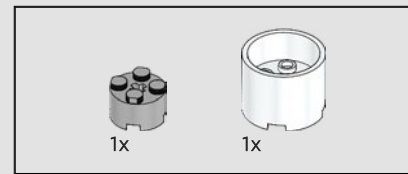
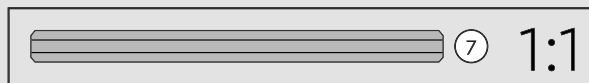
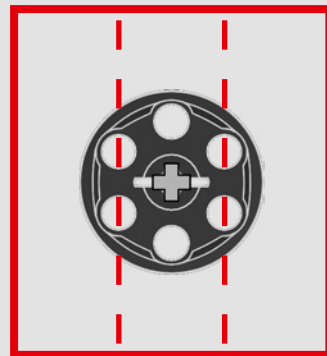
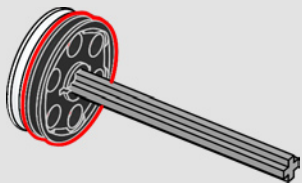

585

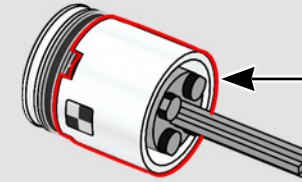
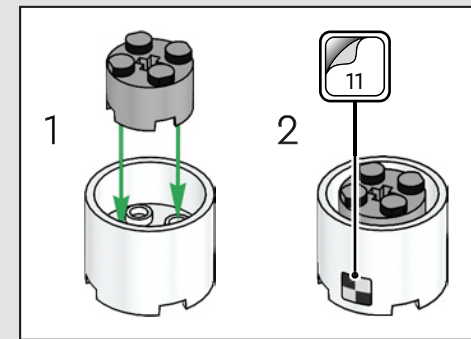

586

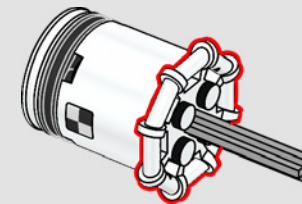

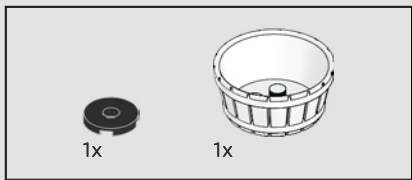

587

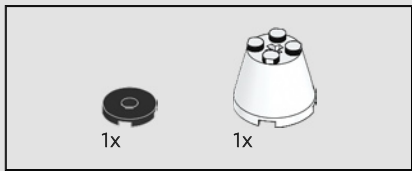
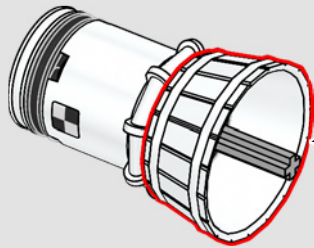
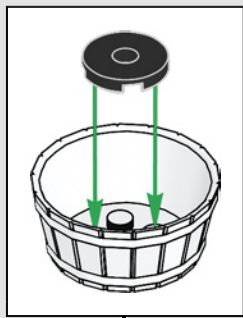

588

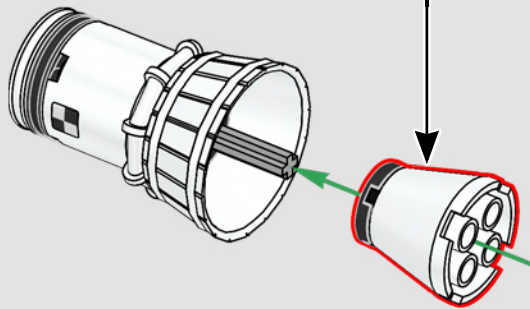
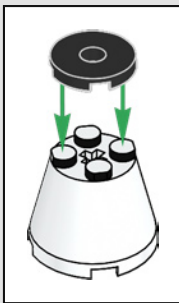

589

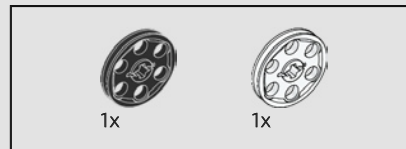
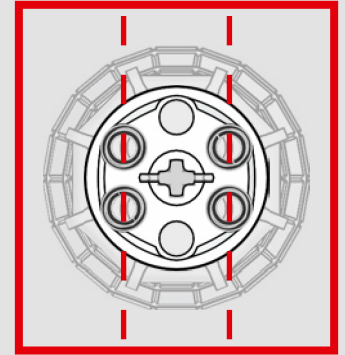
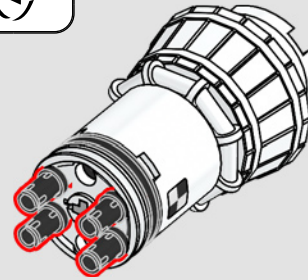
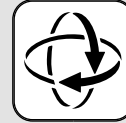

590

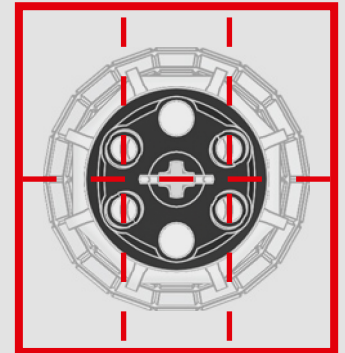
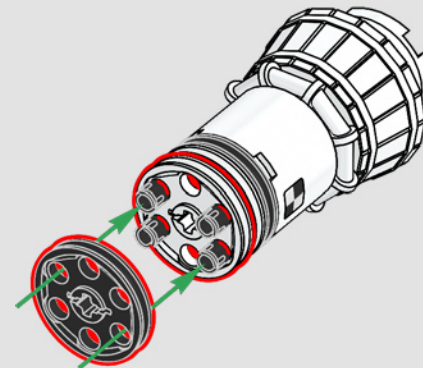



591

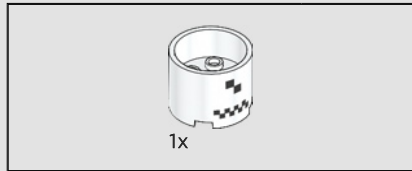
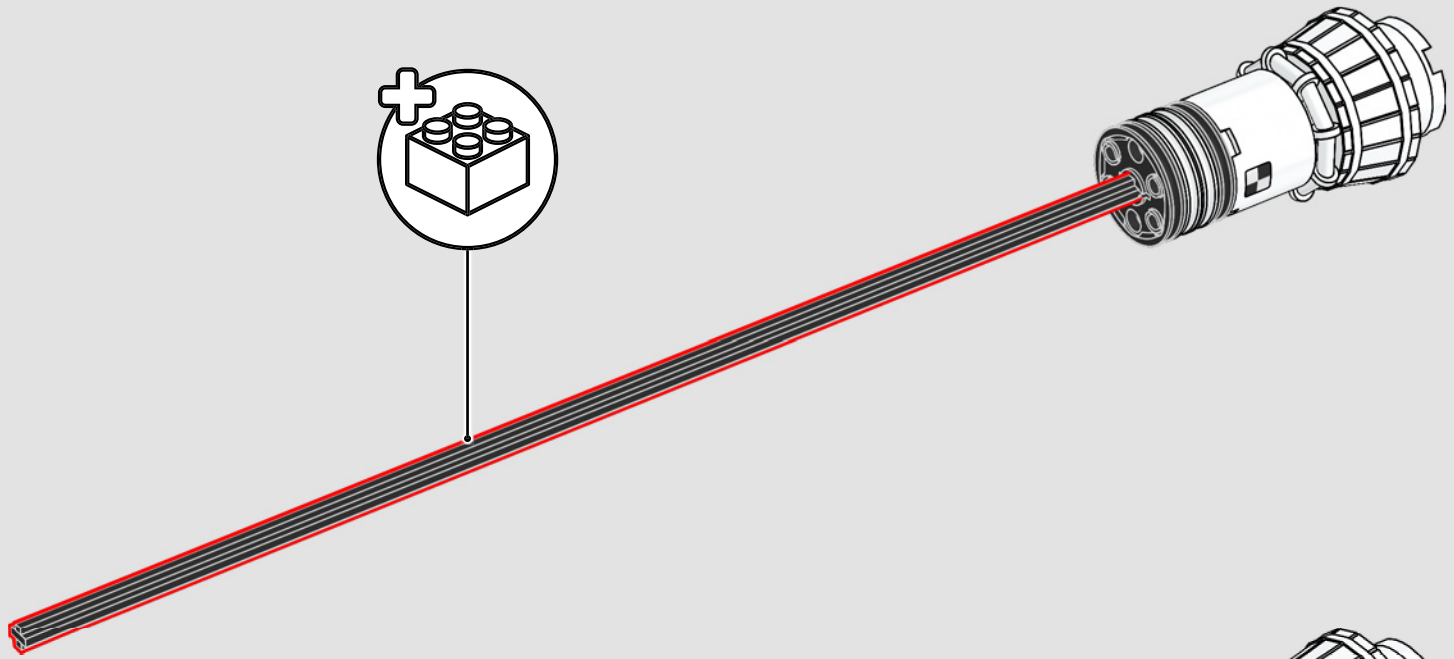

592

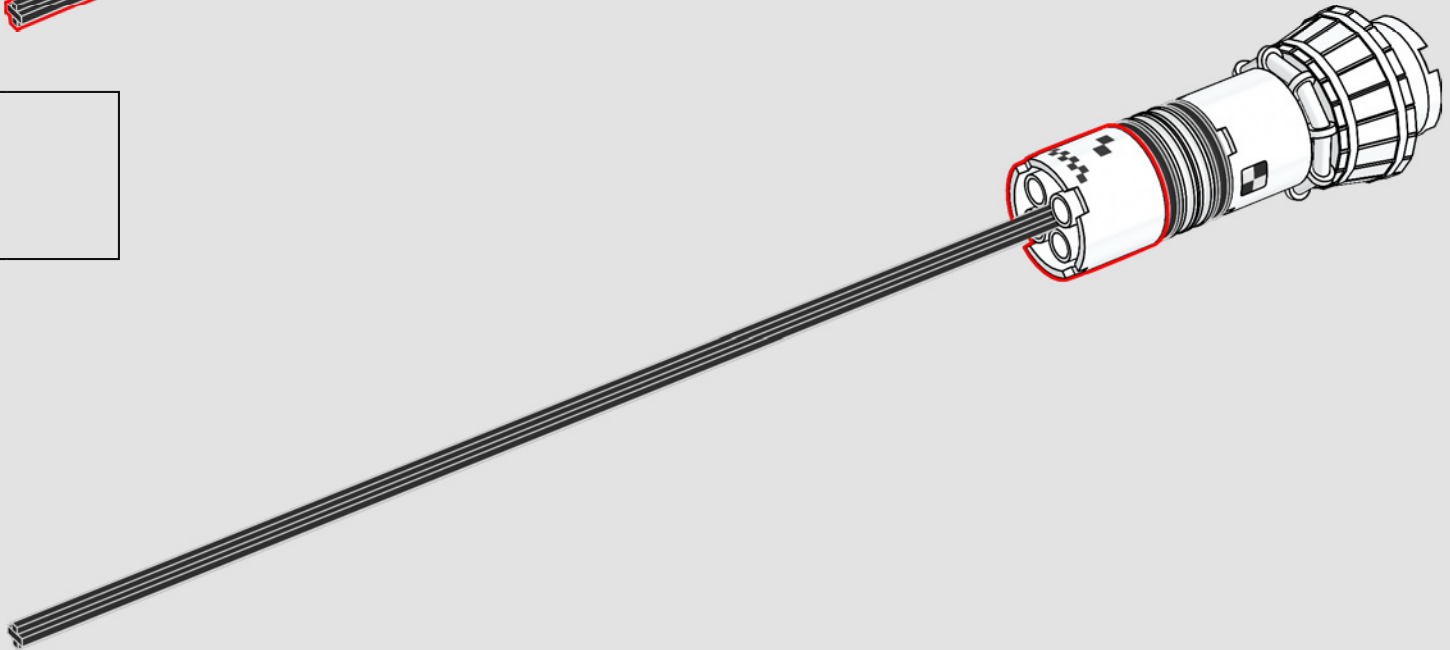

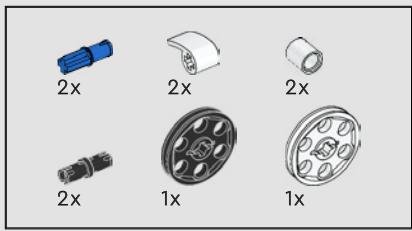

593

1

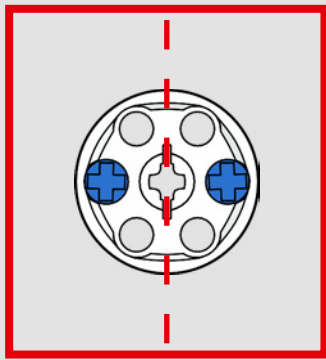
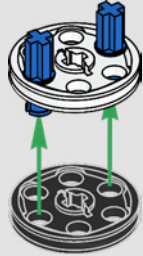

2

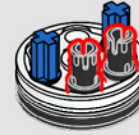

3

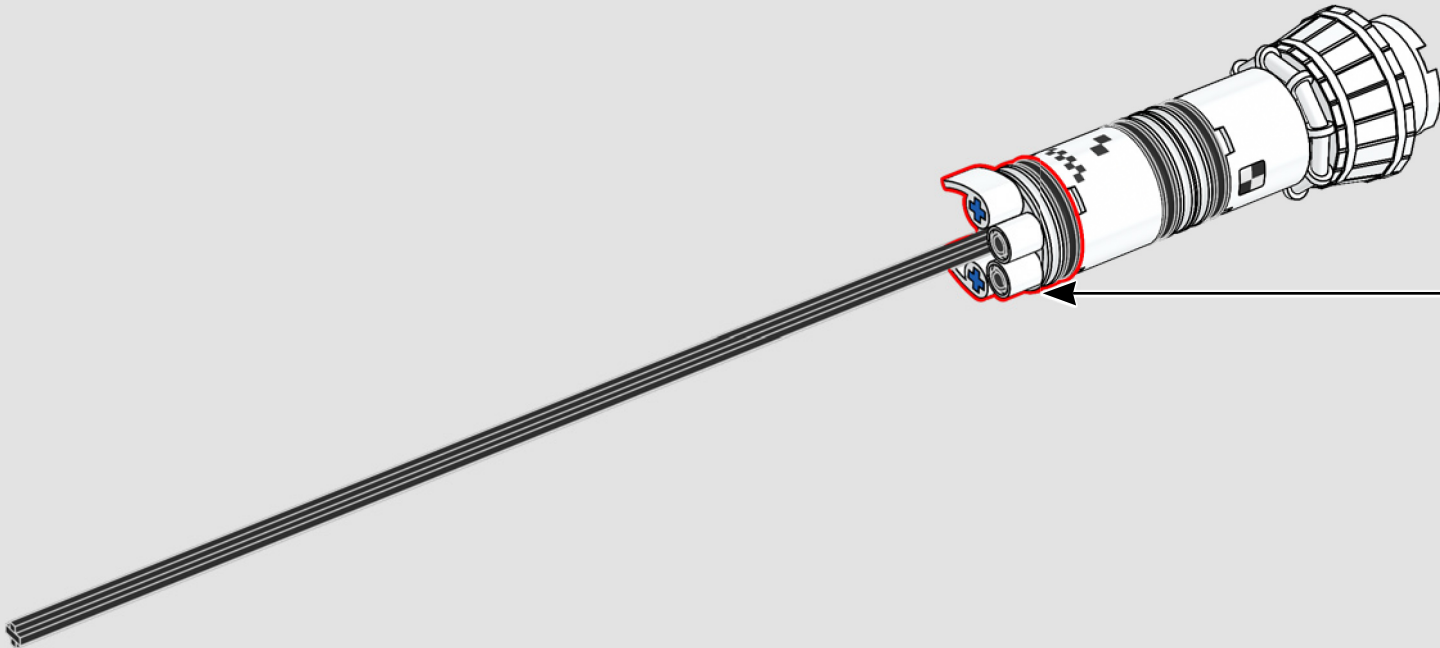



594

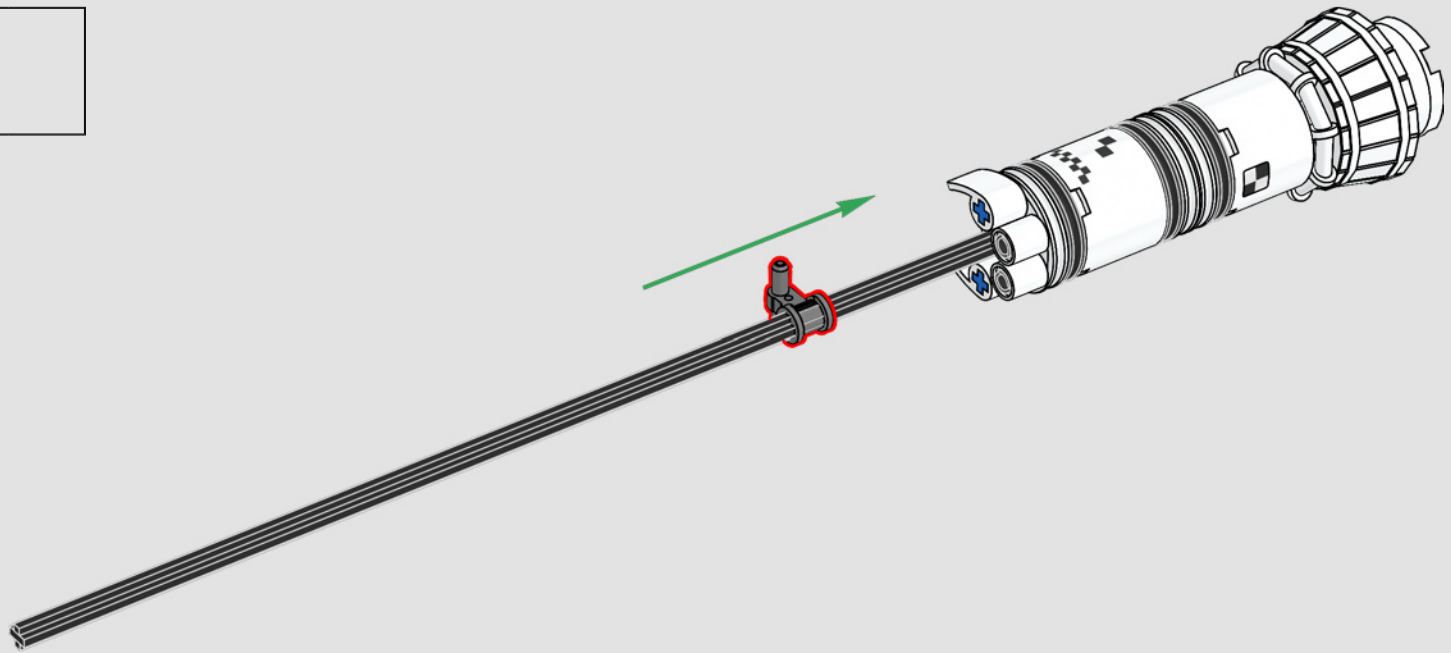

595

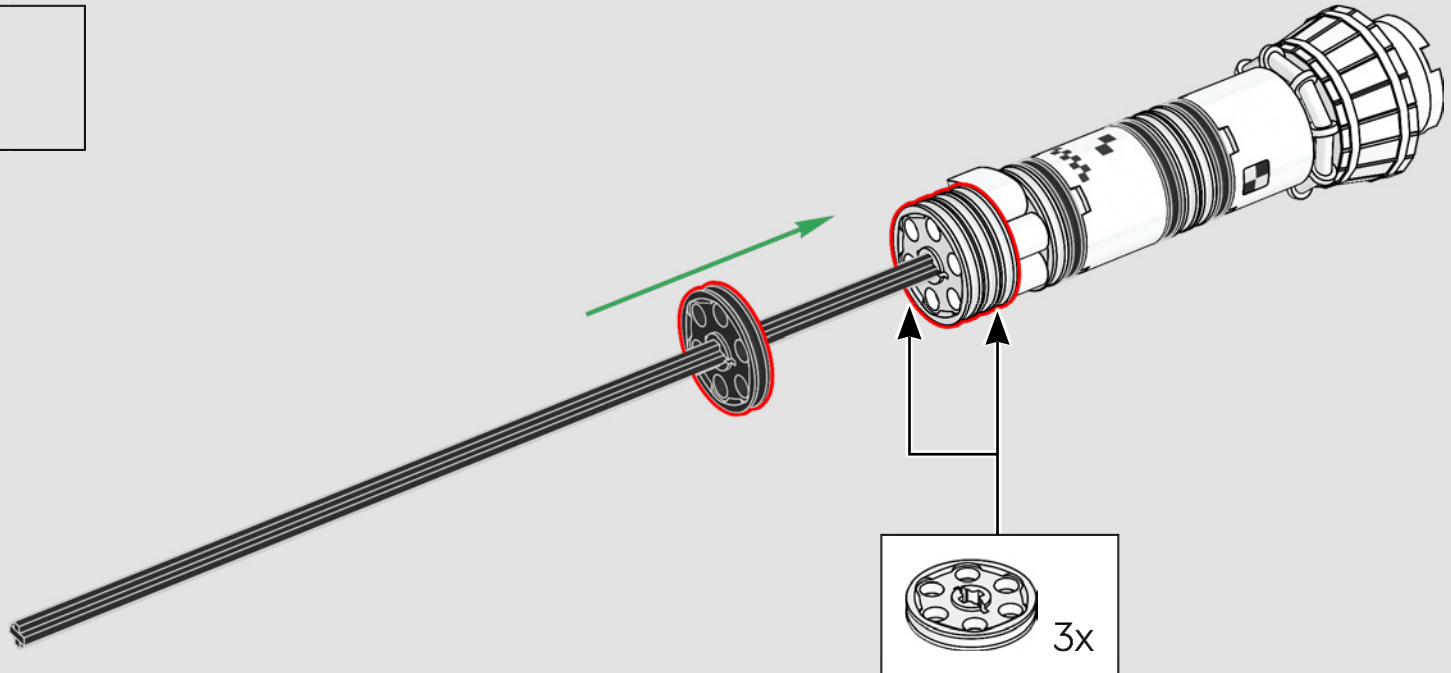

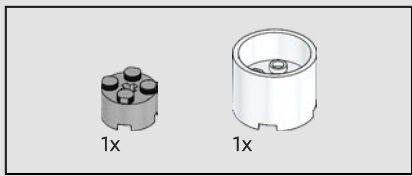

596

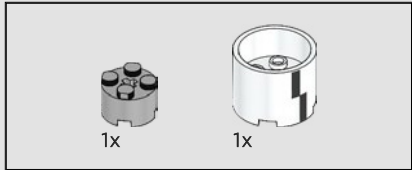
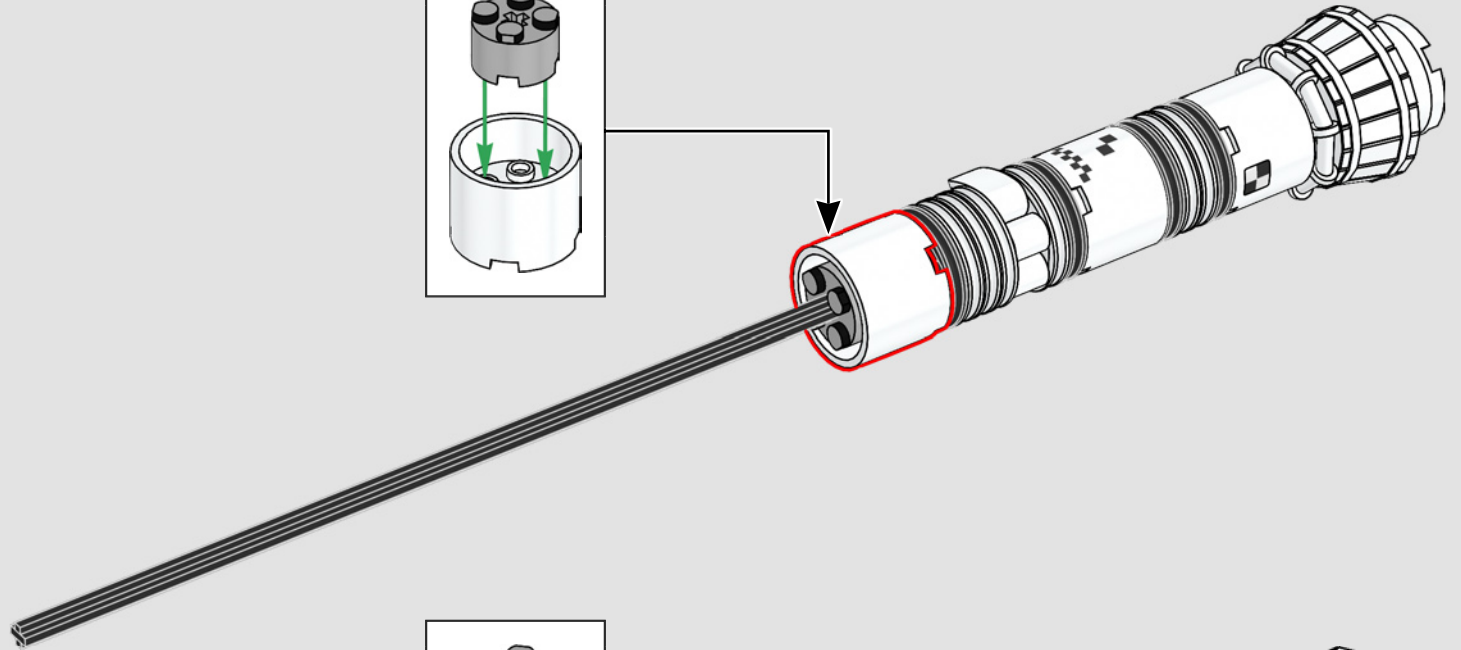
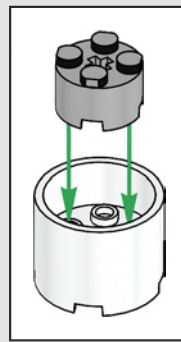

597

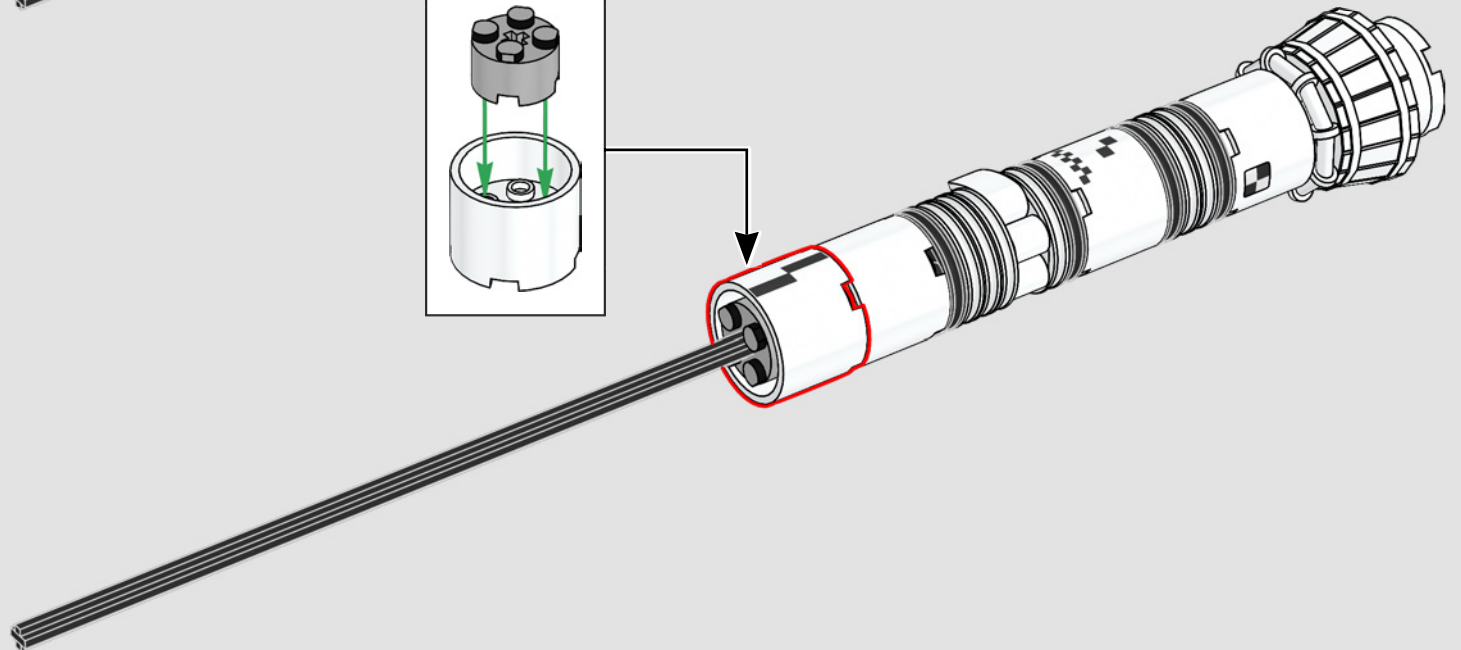
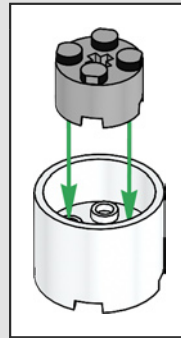

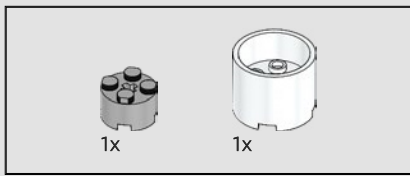

598

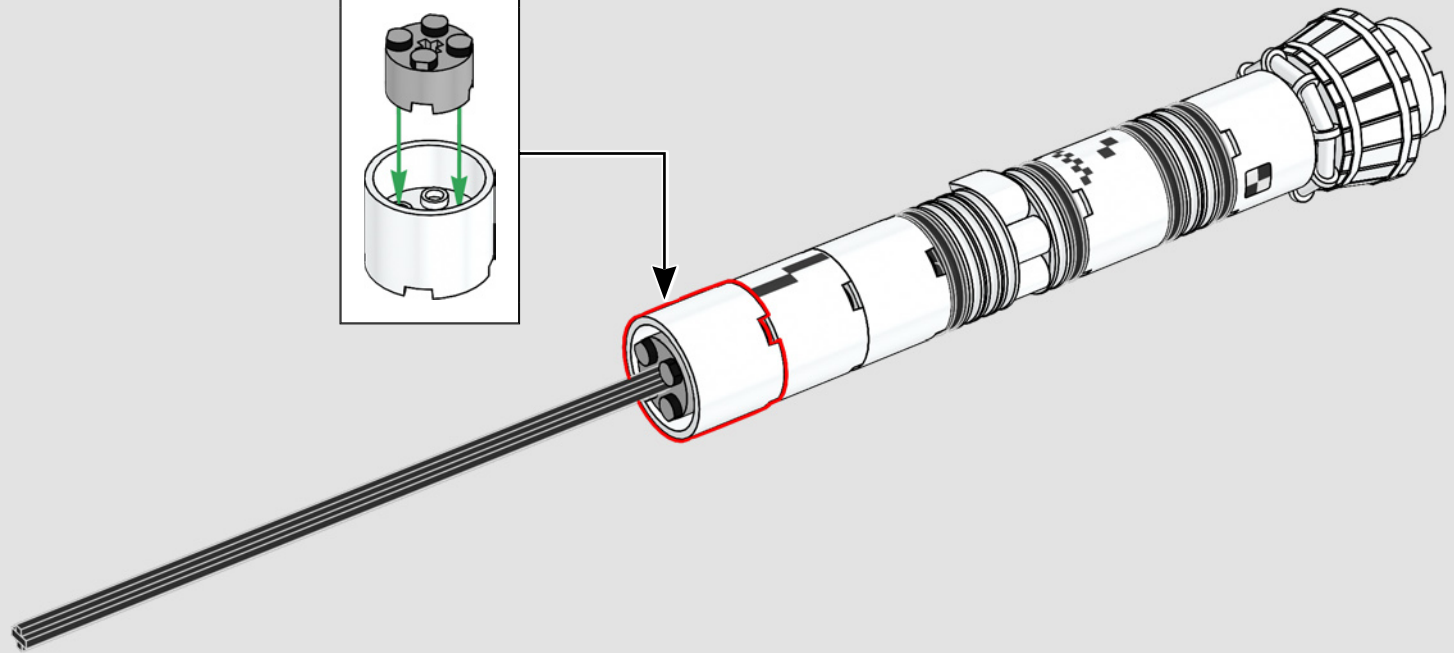
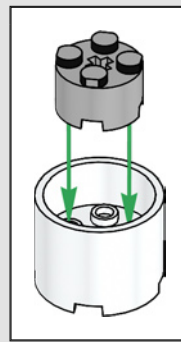

599

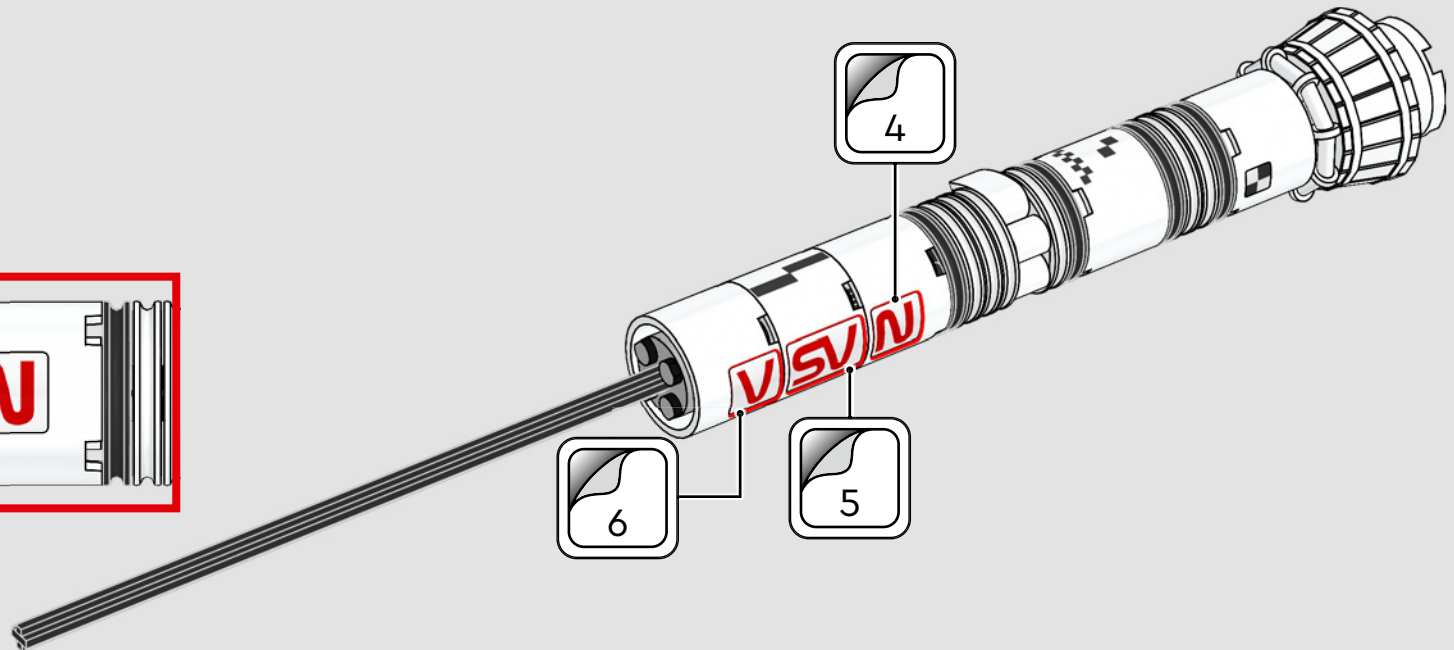
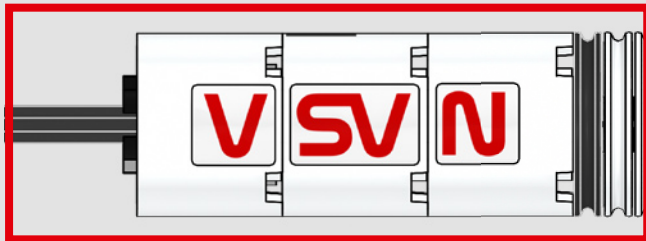

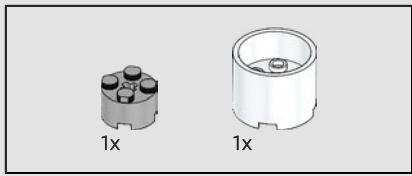

600

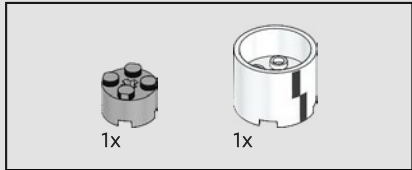
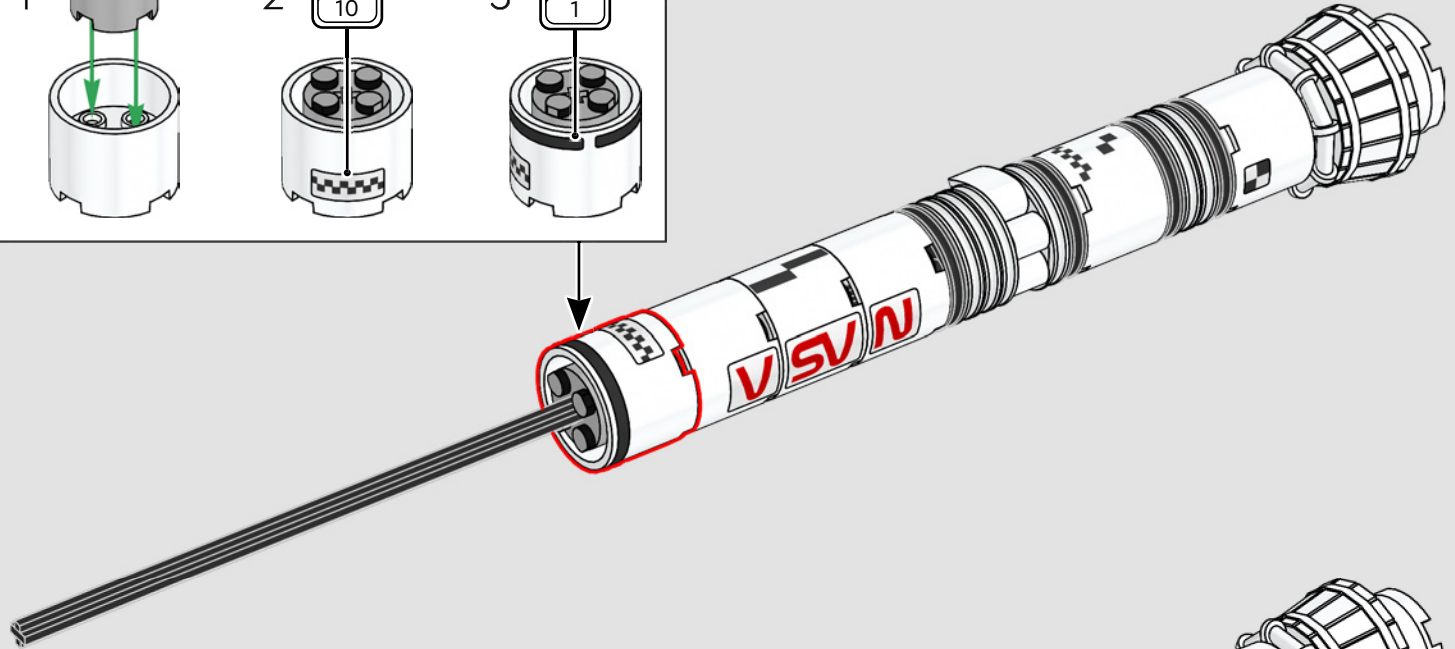
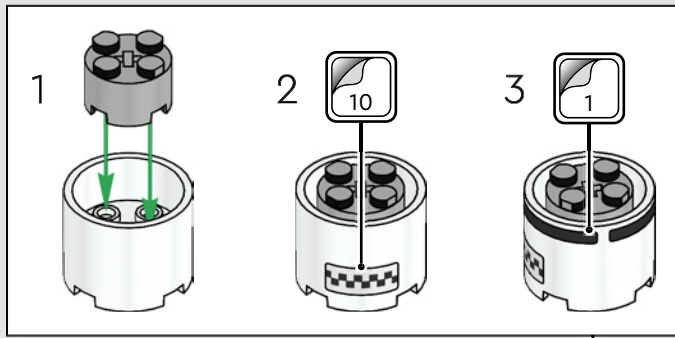

601

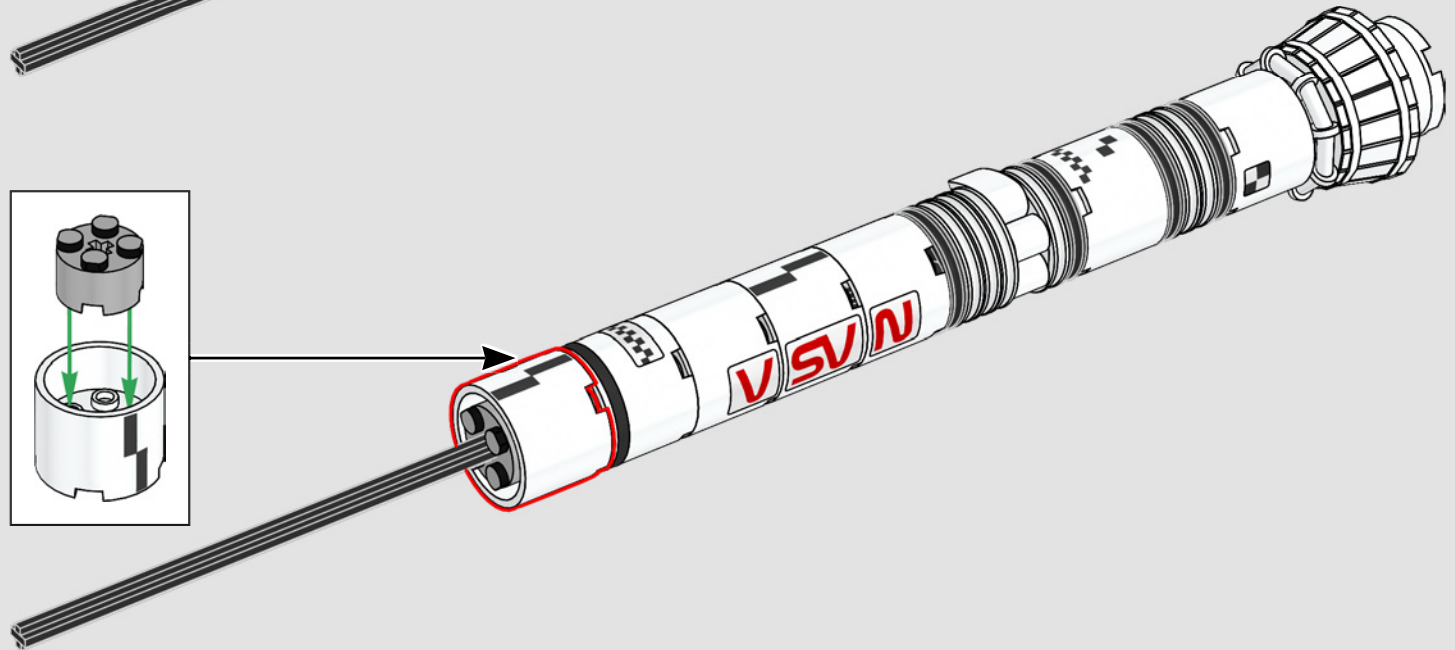
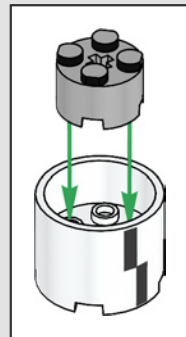

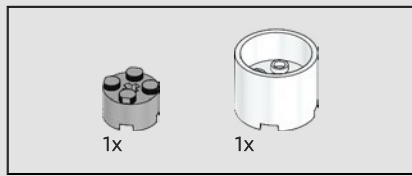

602

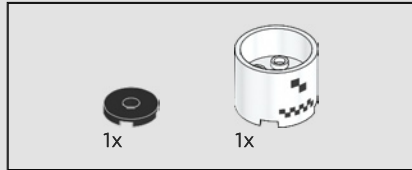
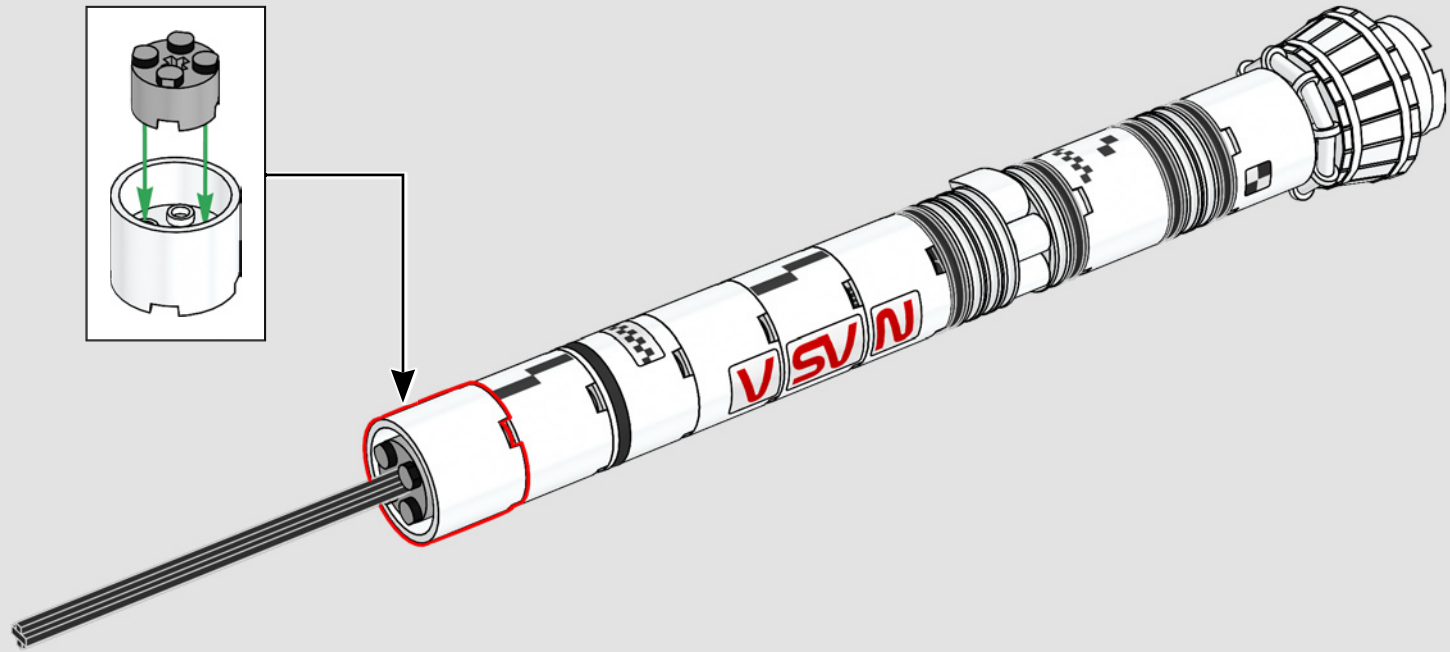
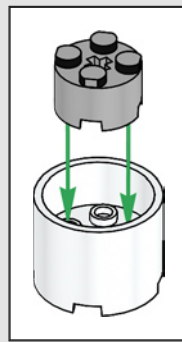

603

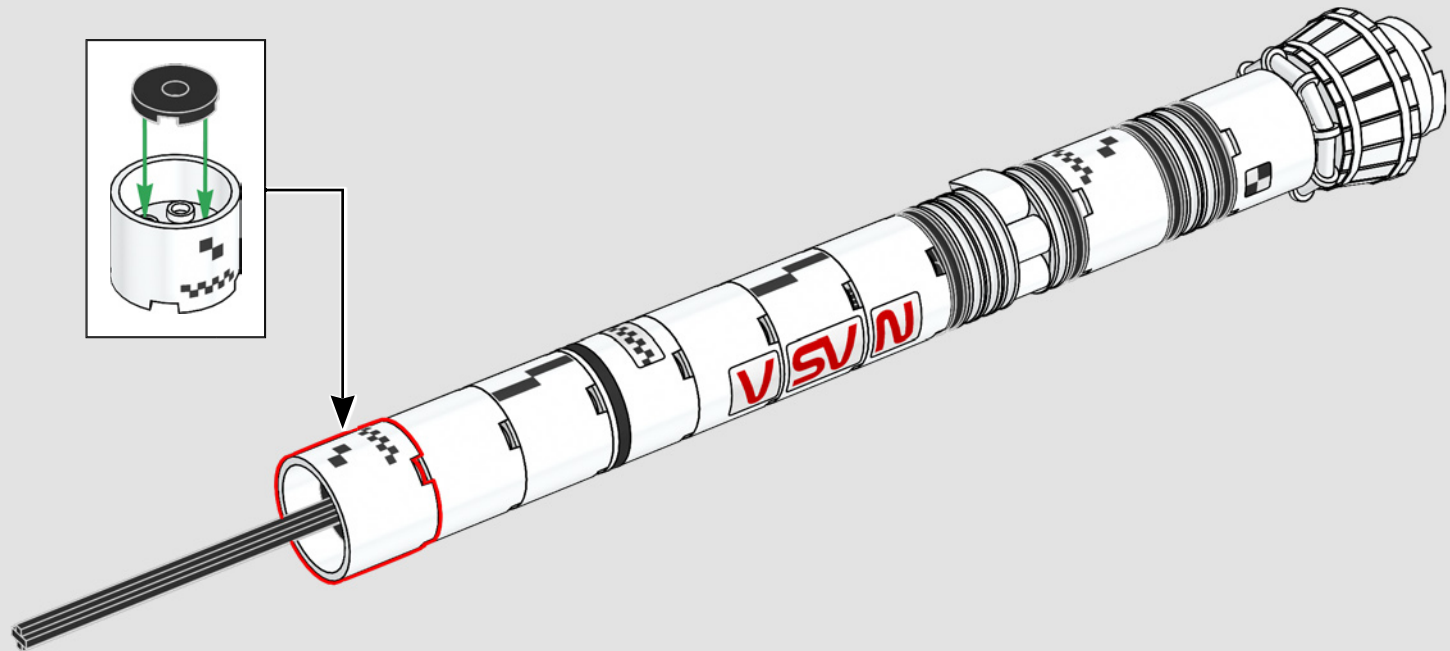
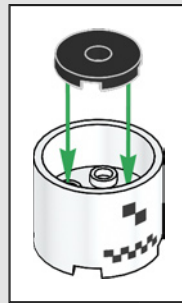

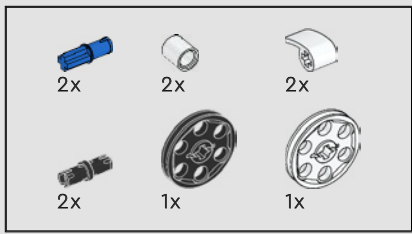

604

1

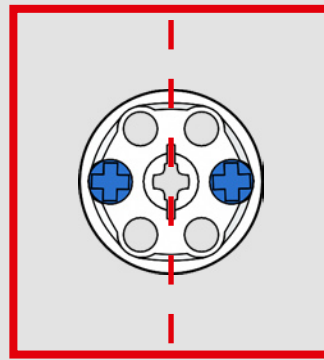
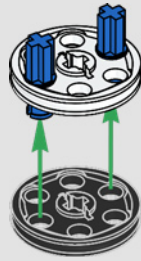

2



3

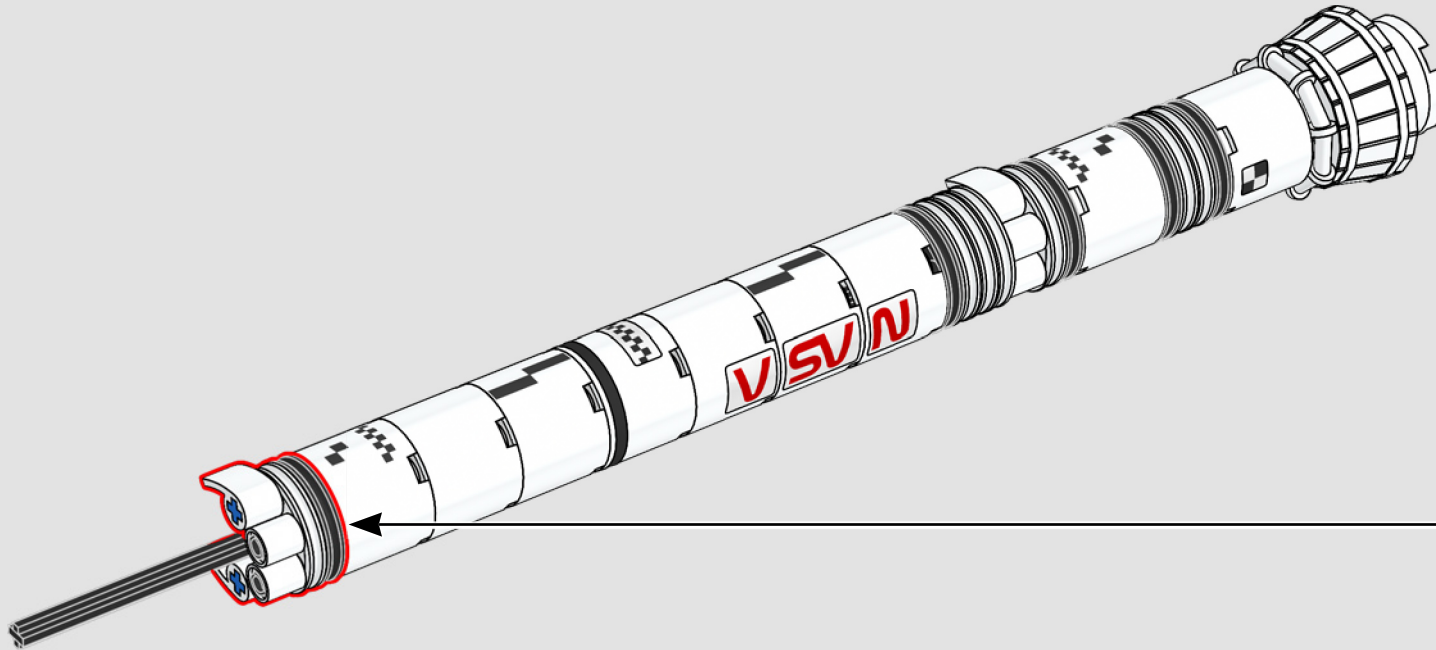





605

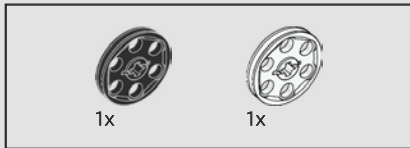
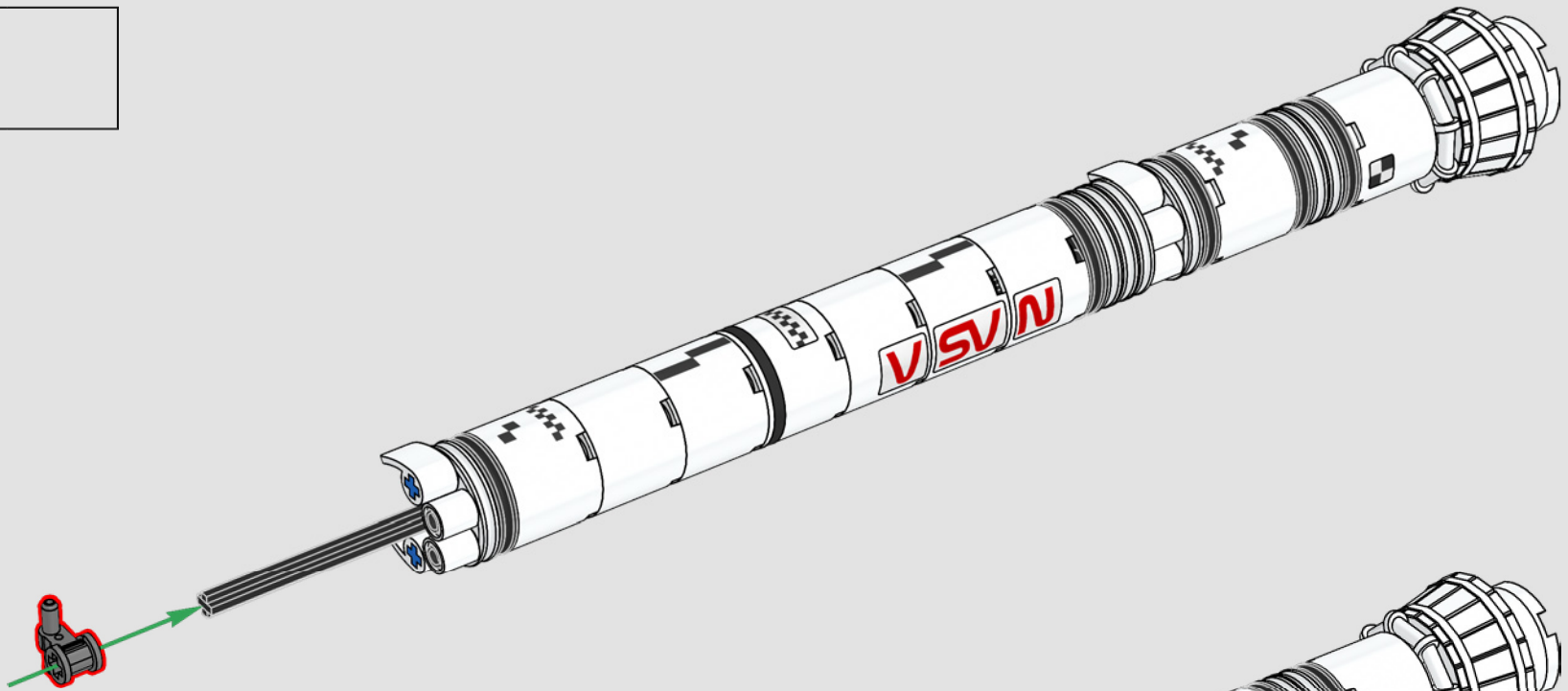

606

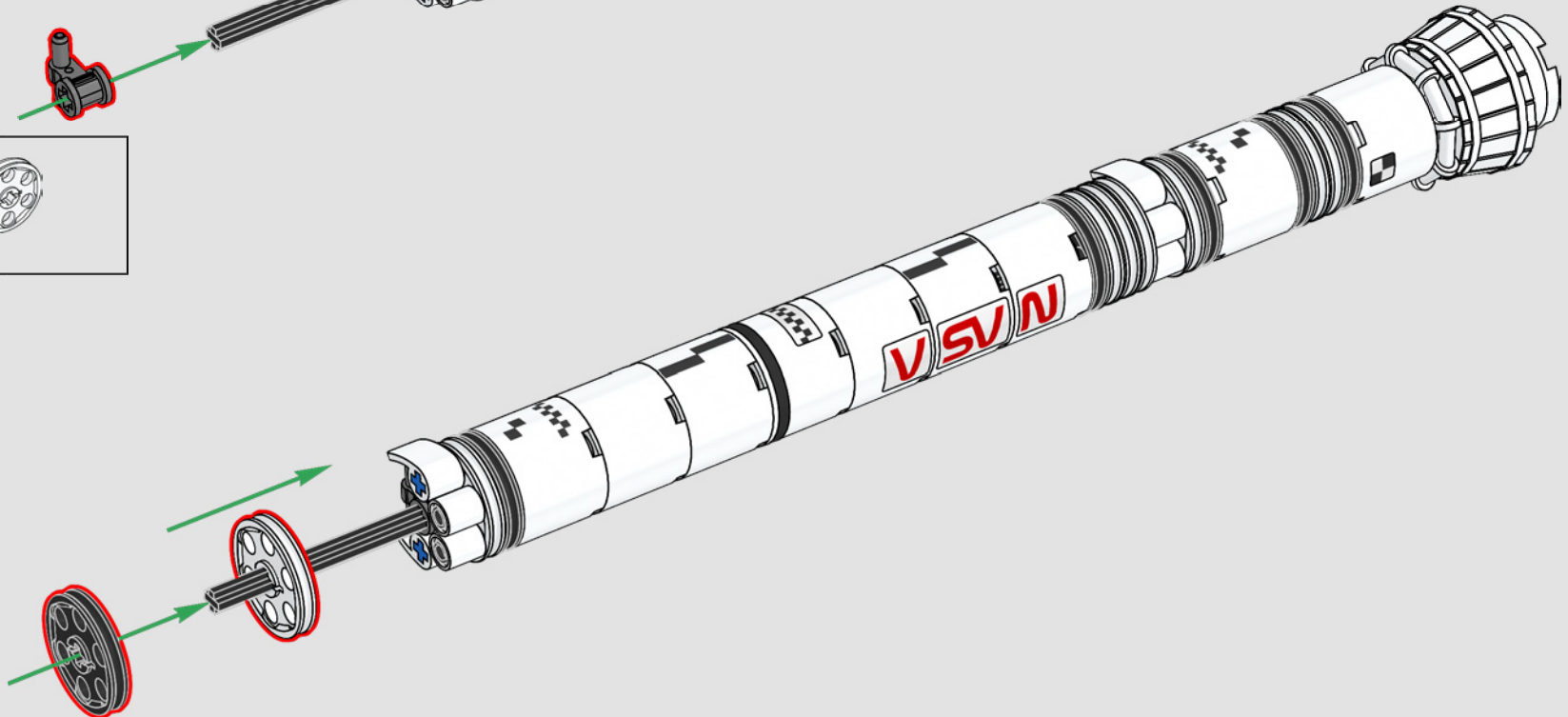

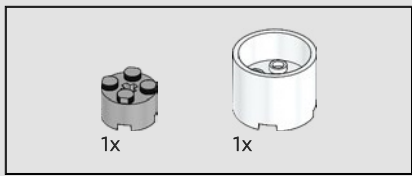

607

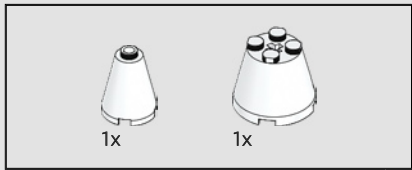
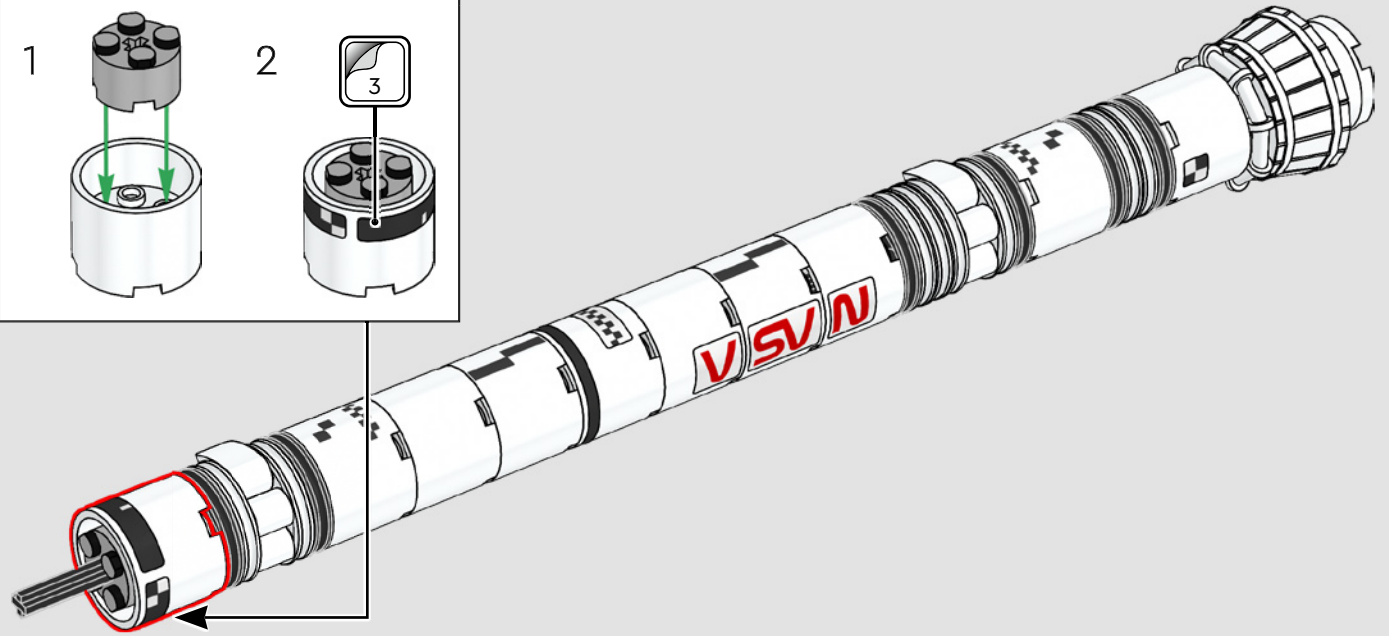
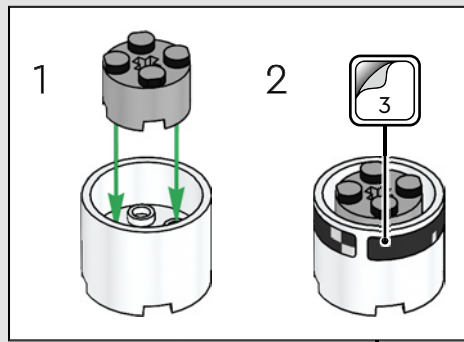

608

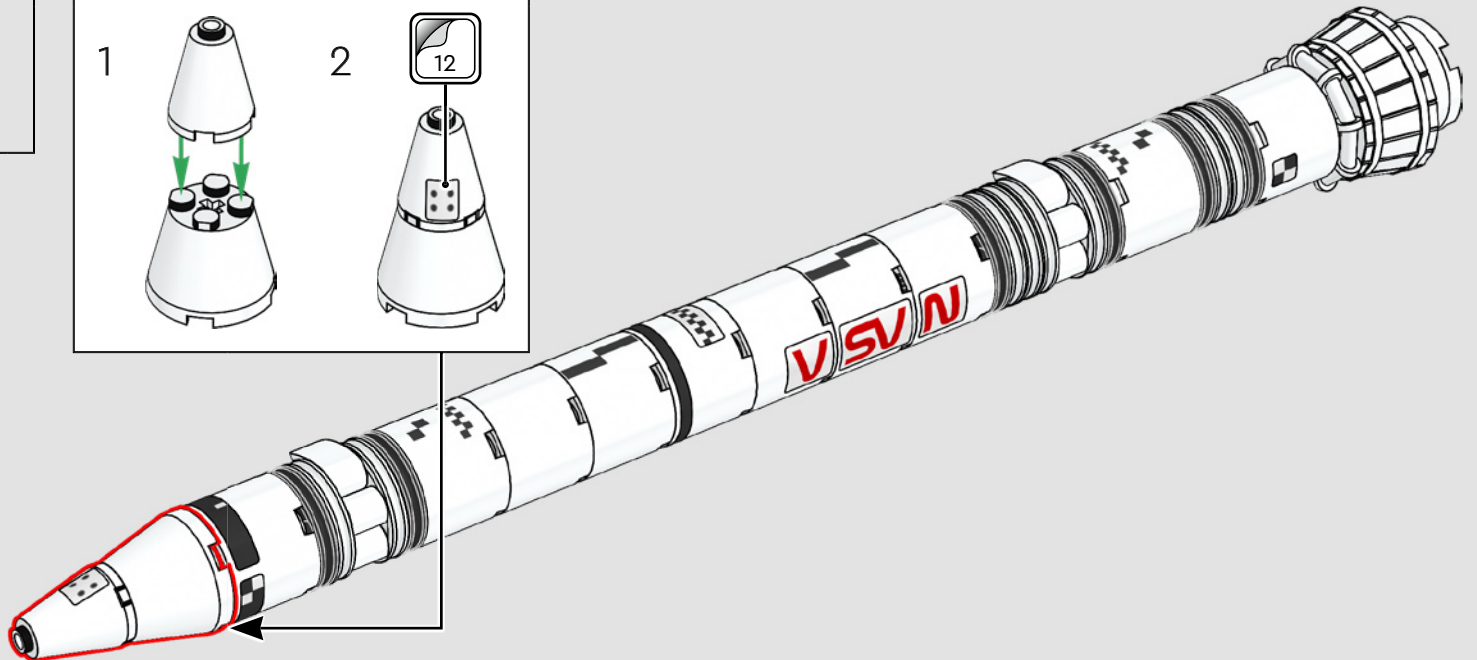
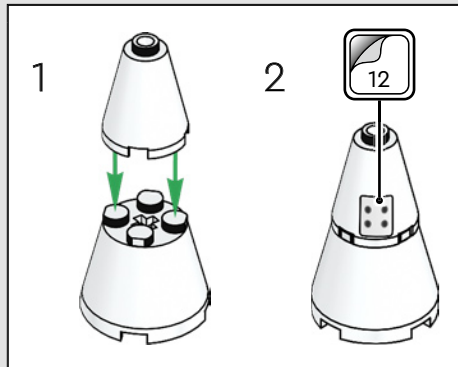

609

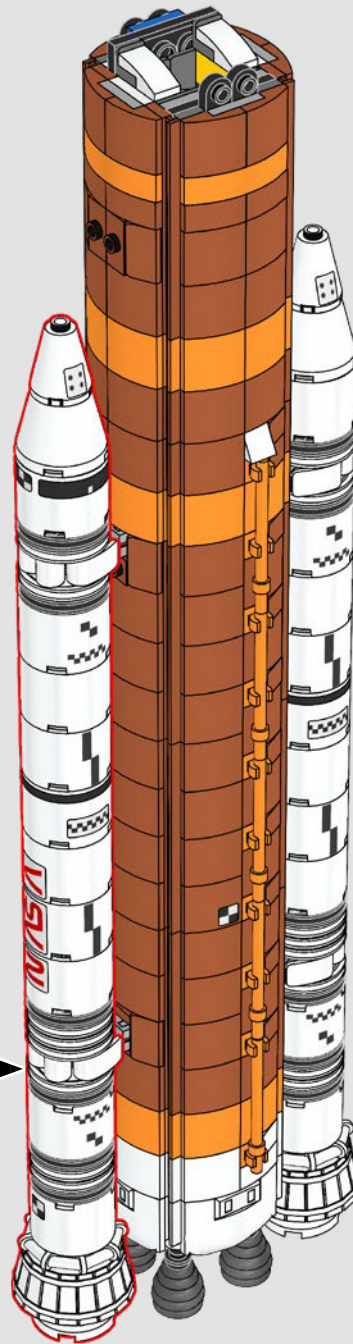

The cone element at the top of the boosters was already used in 1979 LEGO® Classic Space rockets (but had a solid stud with LEGO logo).

L'élément conique au sommet des propulseurs était déjà utilisé dans les fusées LEGO® Classic Space de 1979 (mais il était doté d'un tenon solide avec le logo LEGO).

El elemento cónico de la parte superior de los propulsores ya se había utilizado en los cohetes espaciales LEGO® Classic de 1979 (pero tenía una espiga sólida maciza con el logotipo de LEGO).

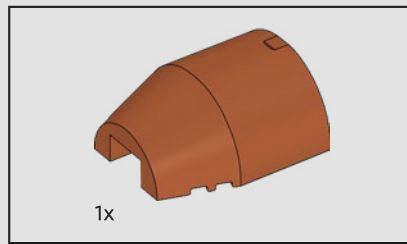

610

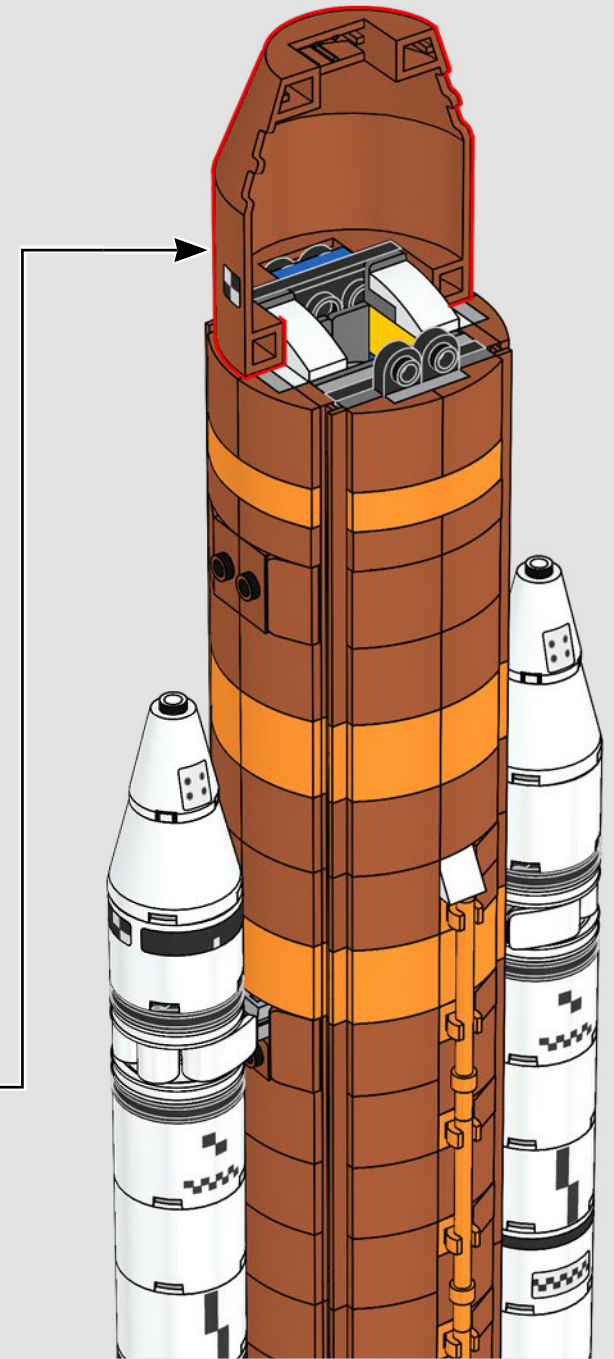
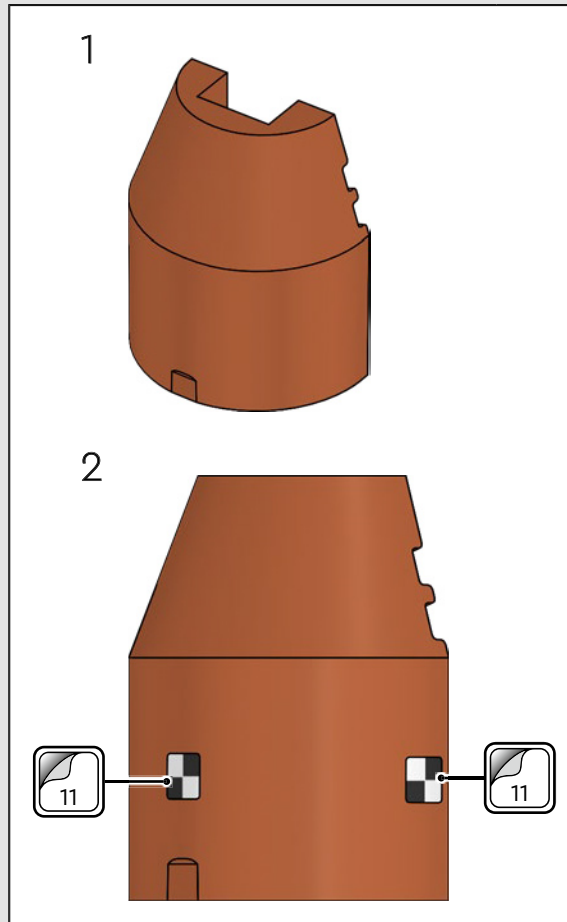

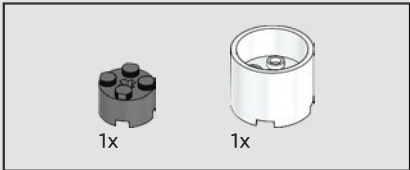
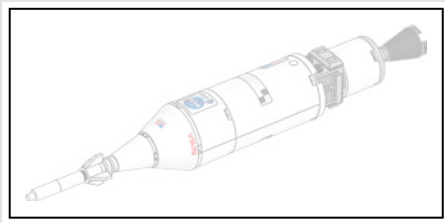

611

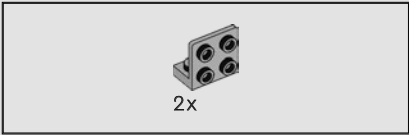
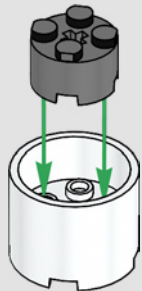

612

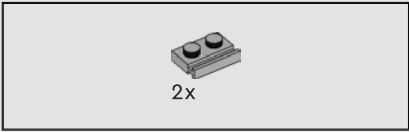
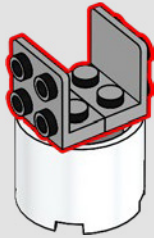

613

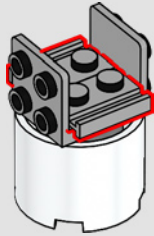

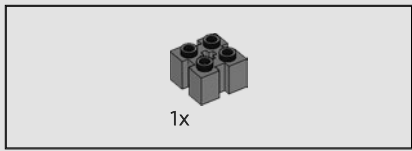

614

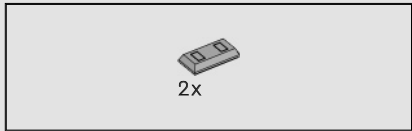
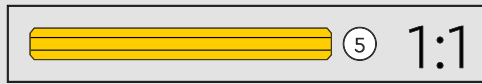
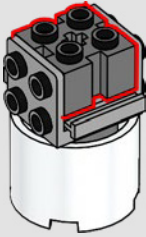

615

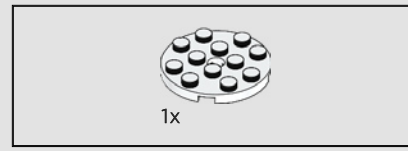
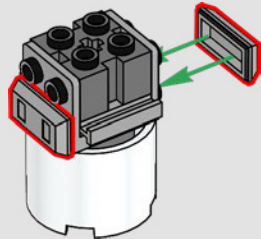

616

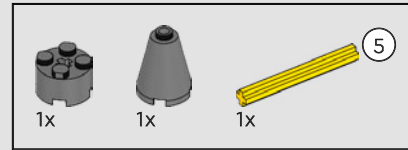
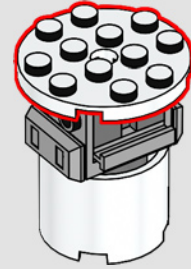

617

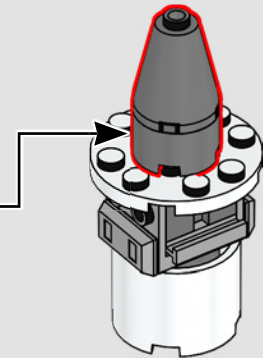
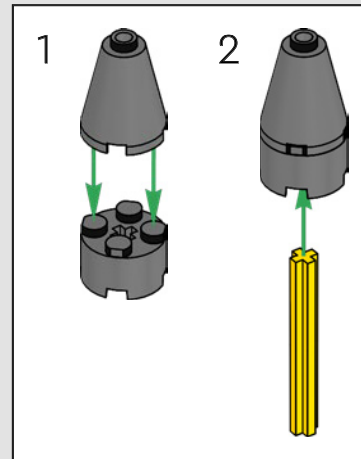

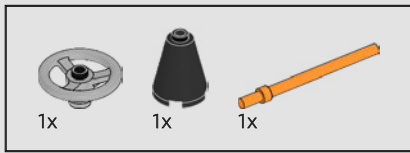

618

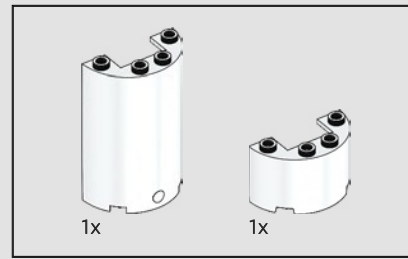
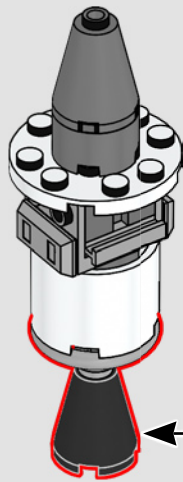
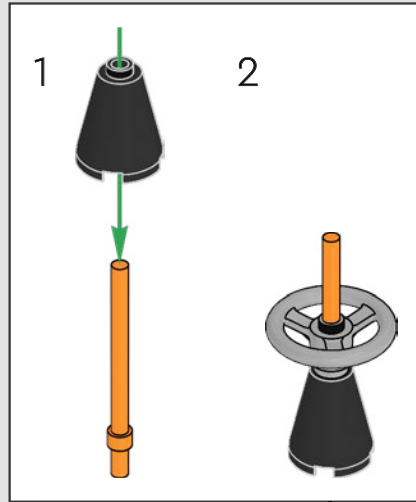

619

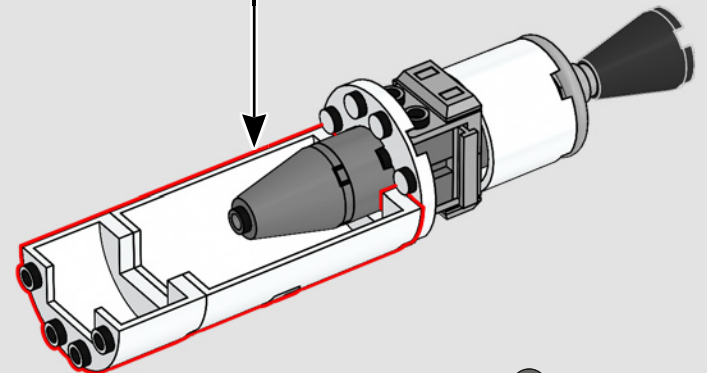
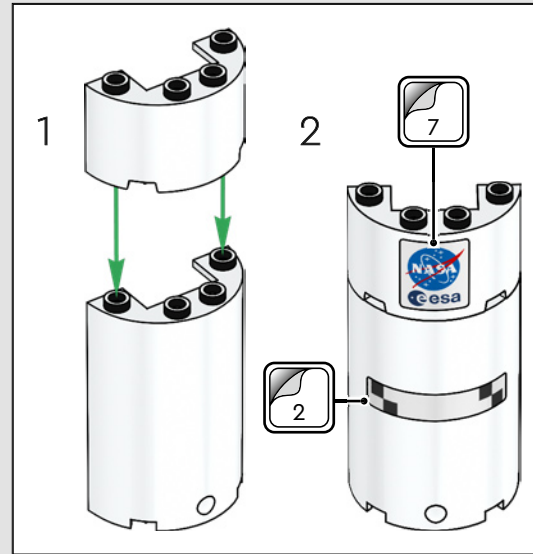

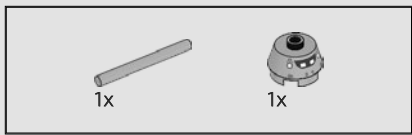

620

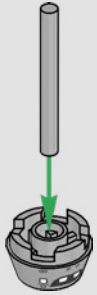

621

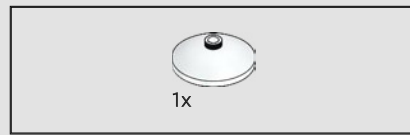
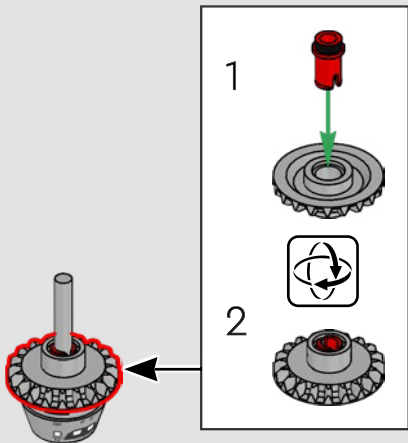

622

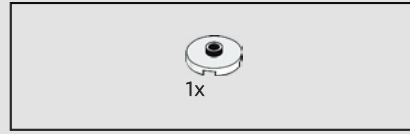
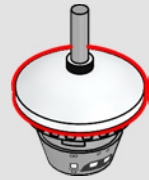

623

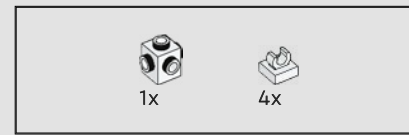
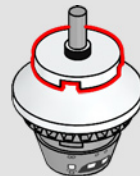

624

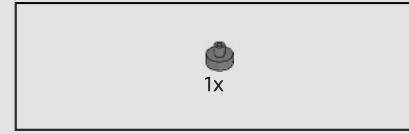
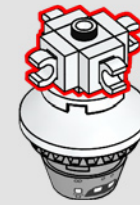

625

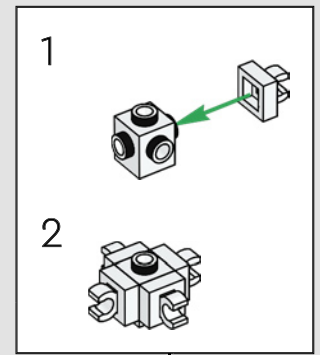
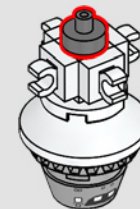



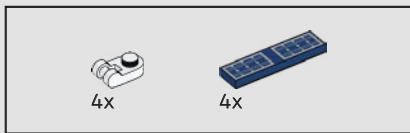

626

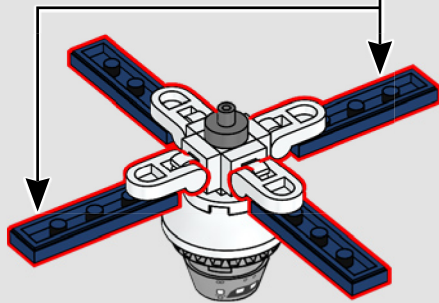
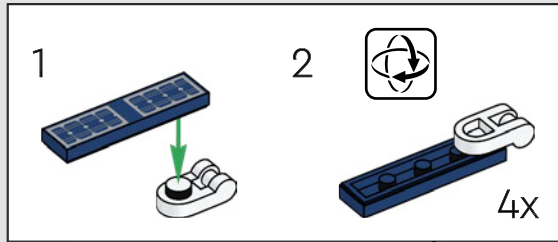

627

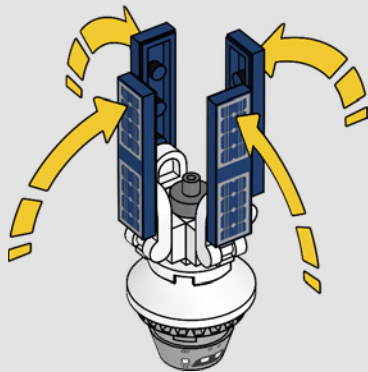

628

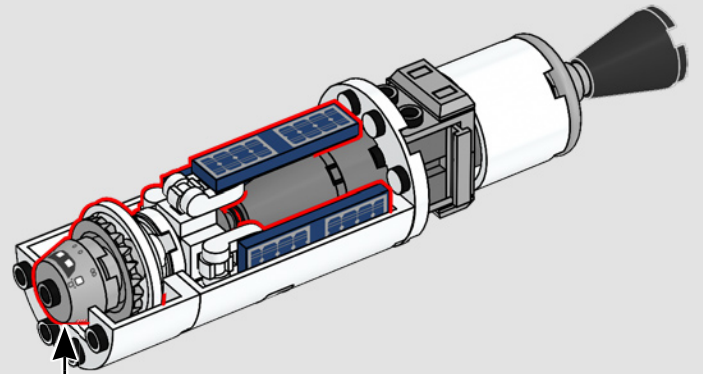

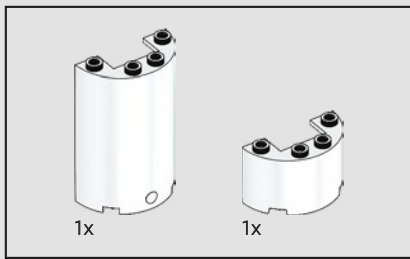

629

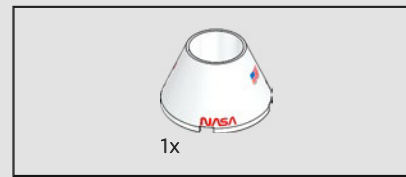
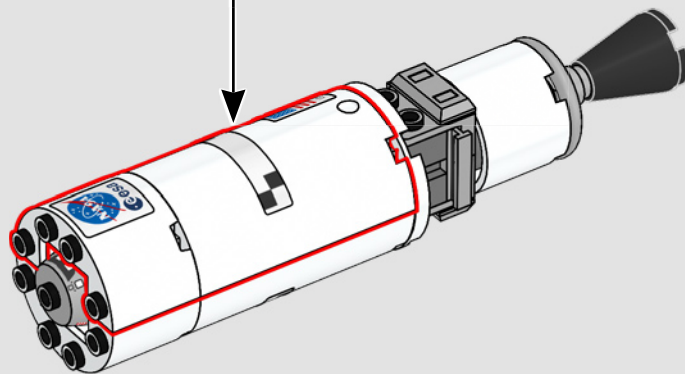
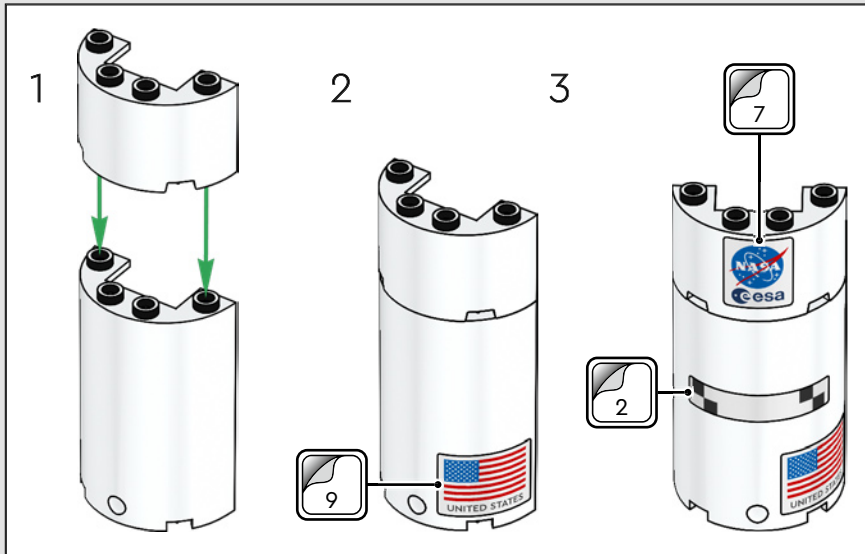

630

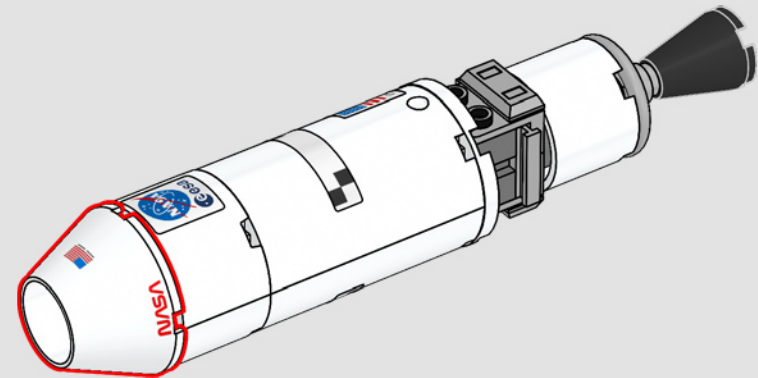

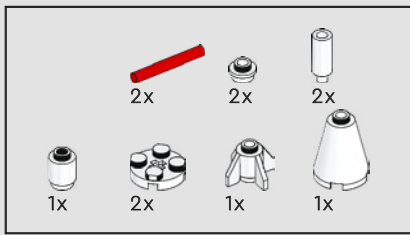

631

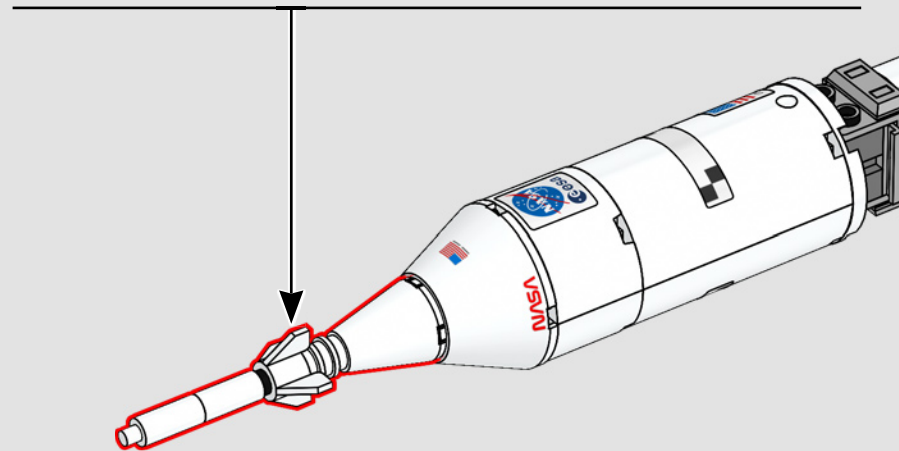
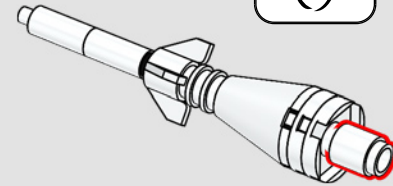
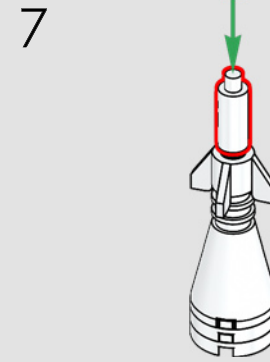
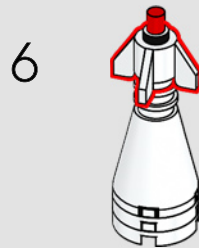
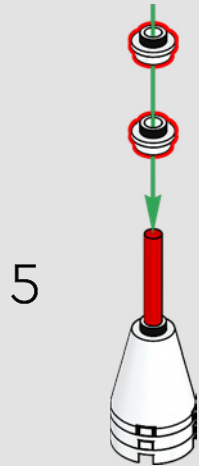
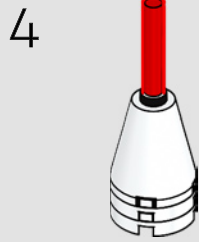
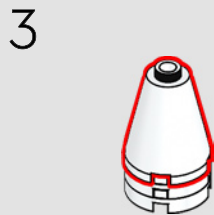
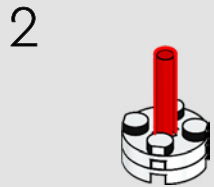
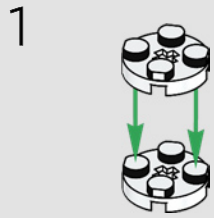

632

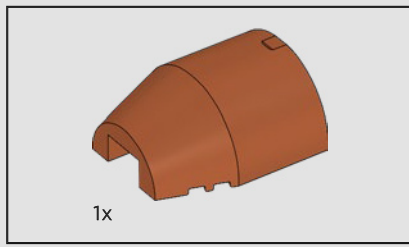
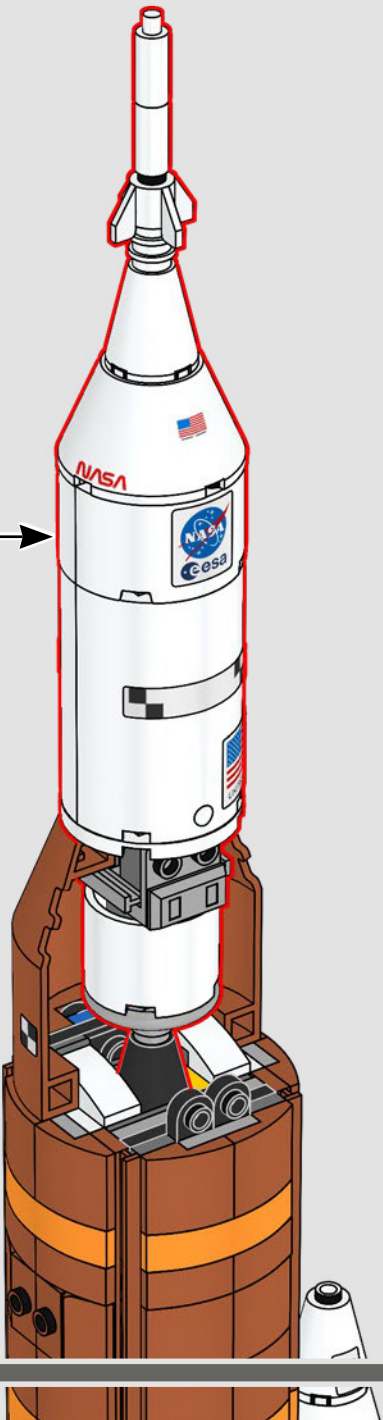

633

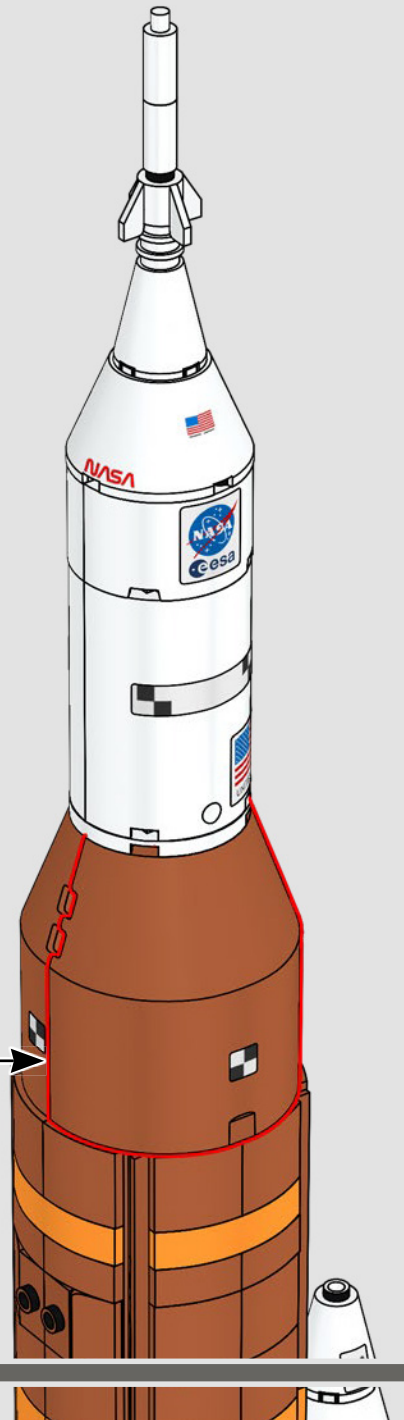
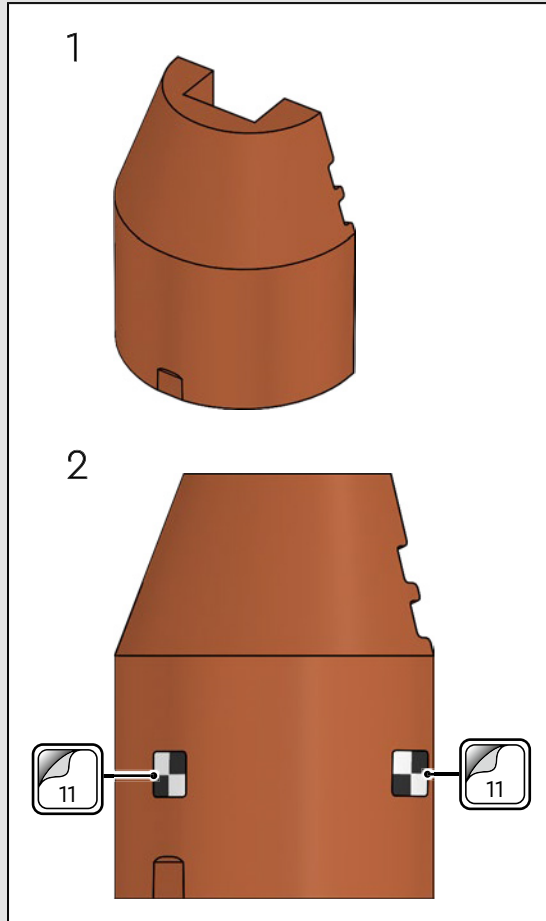

634

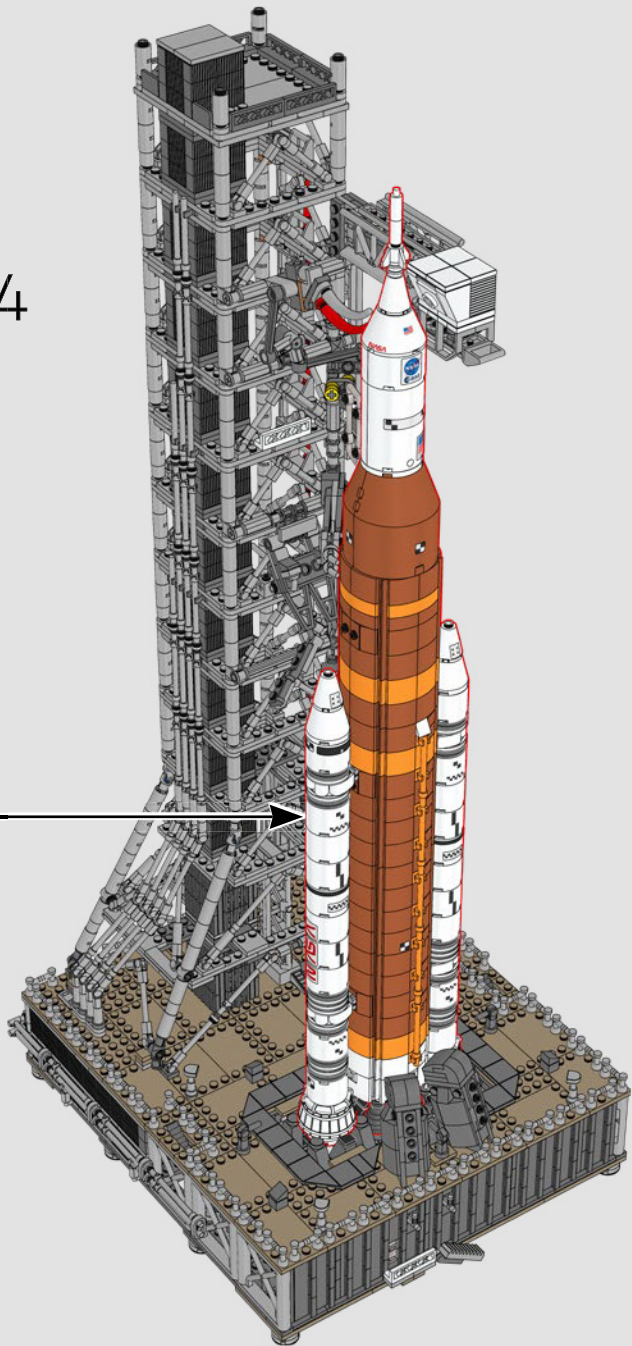

635

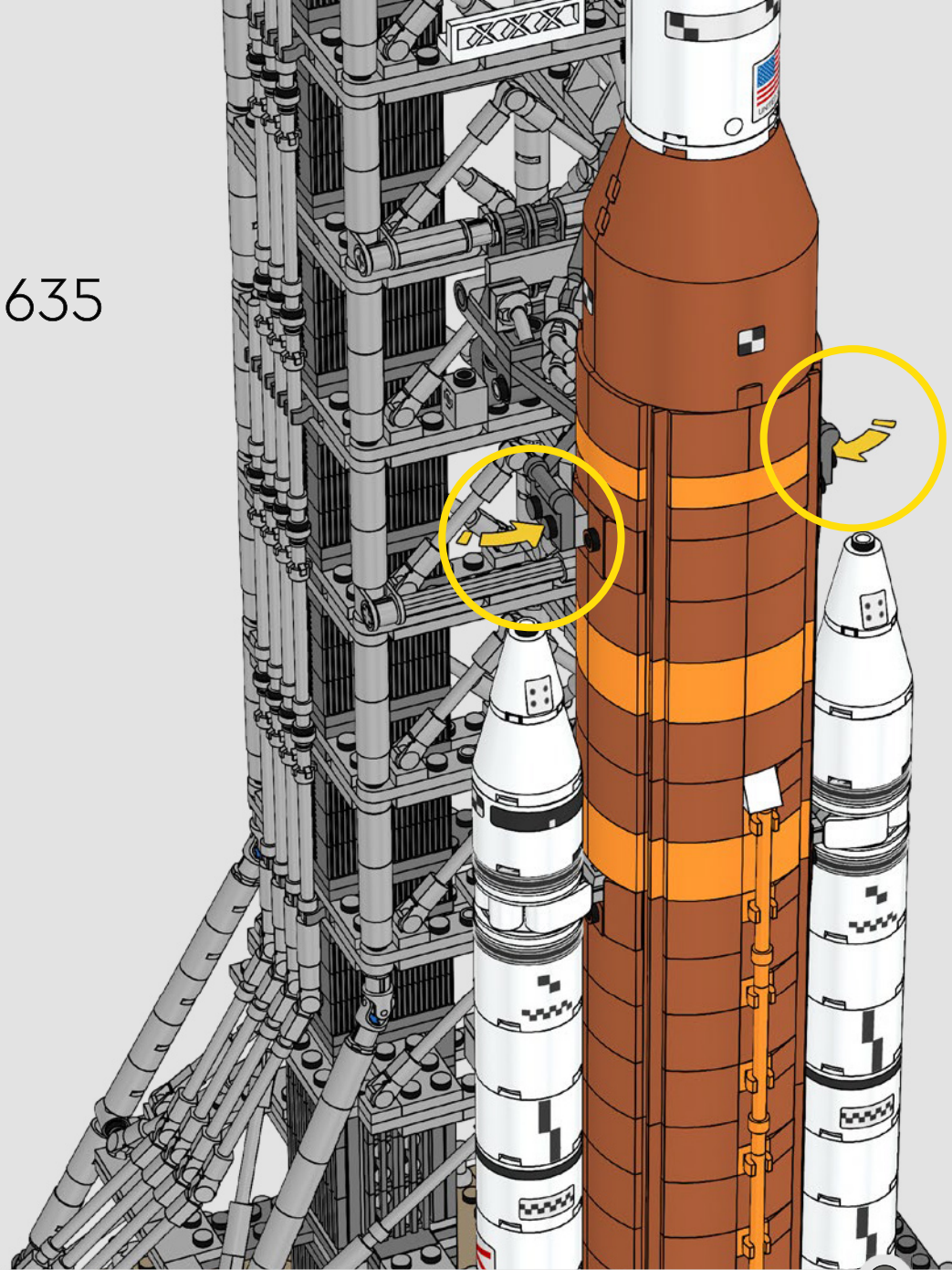

Like in real life, the whole rocket rests on the skirts of the boosters.

Comme dans la réalité, la fusée entière repose sur les jupes des propulseurs d'appoint.

Al igual que en la vida real, todo el cohete se apoya sobre los faldones de los propulsores.

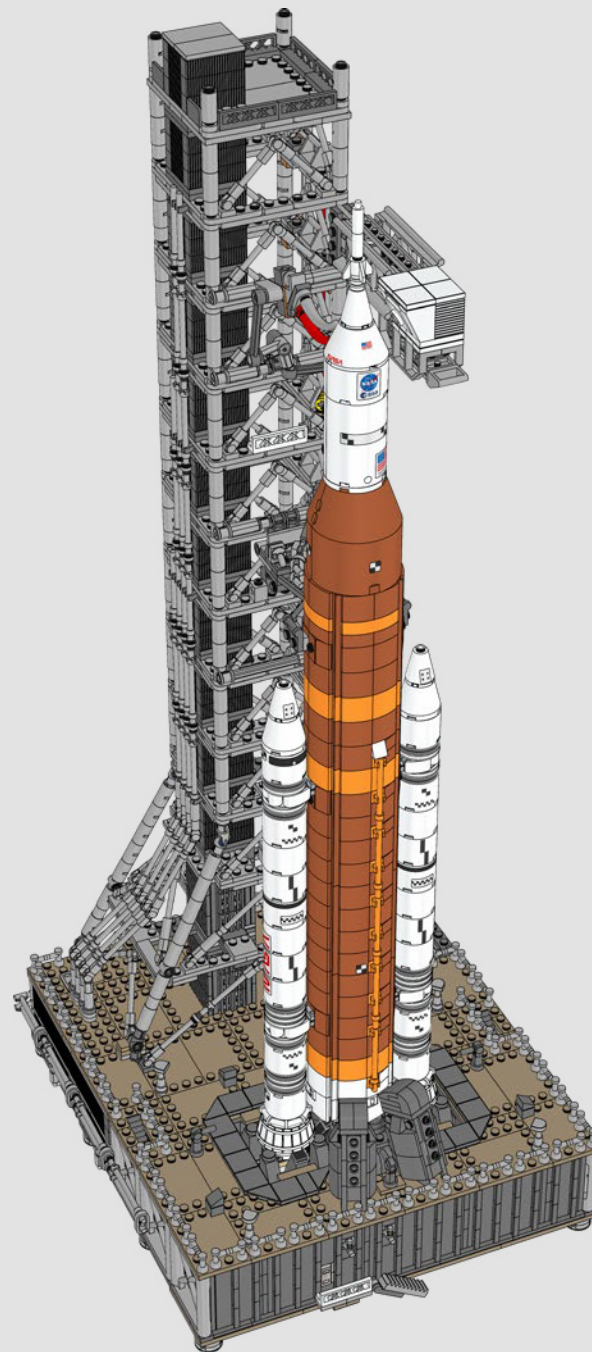

1

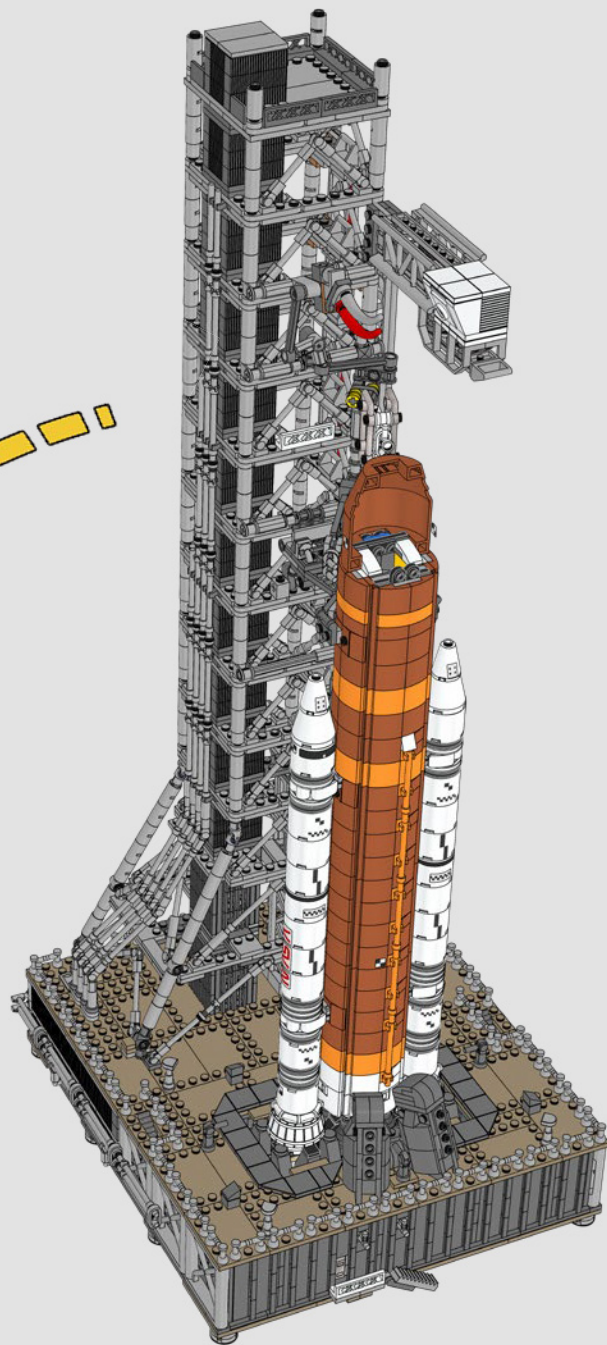
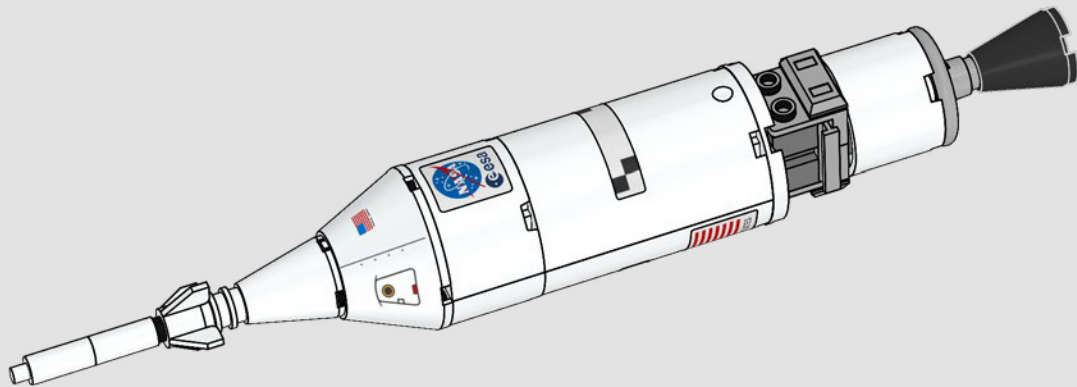
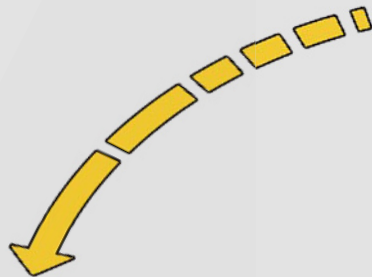
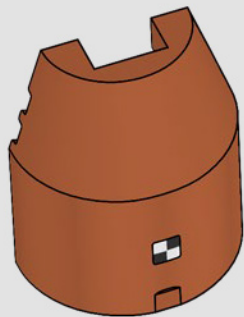

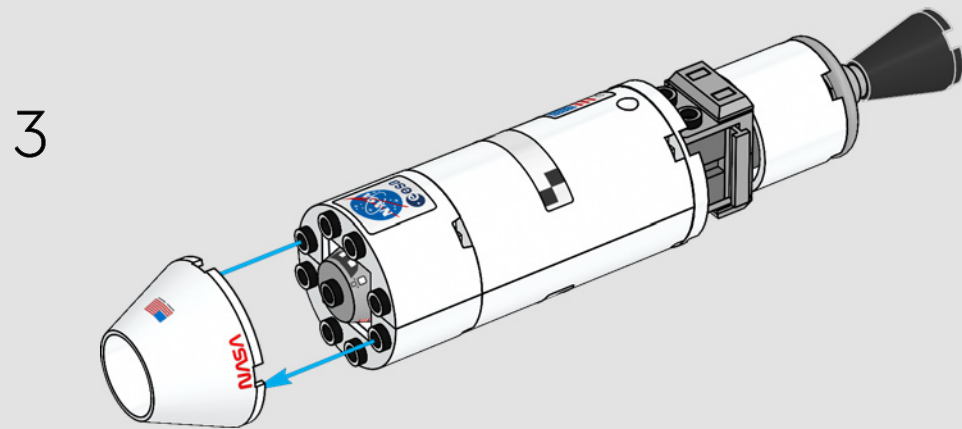
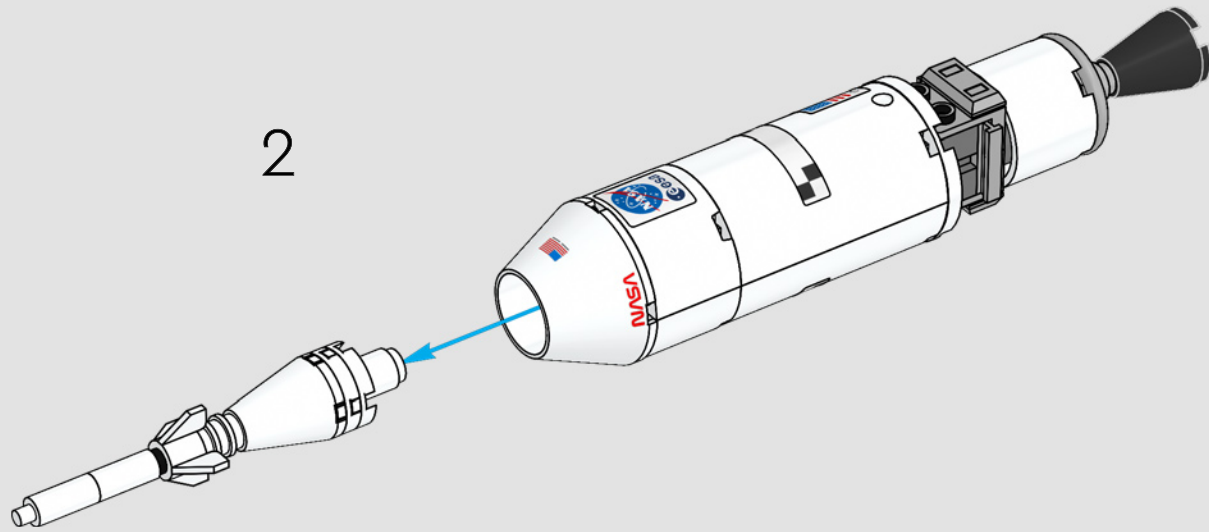



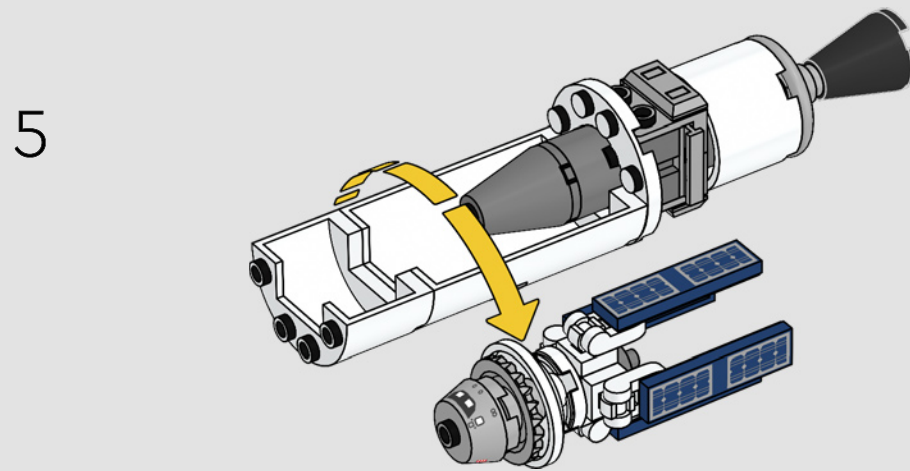
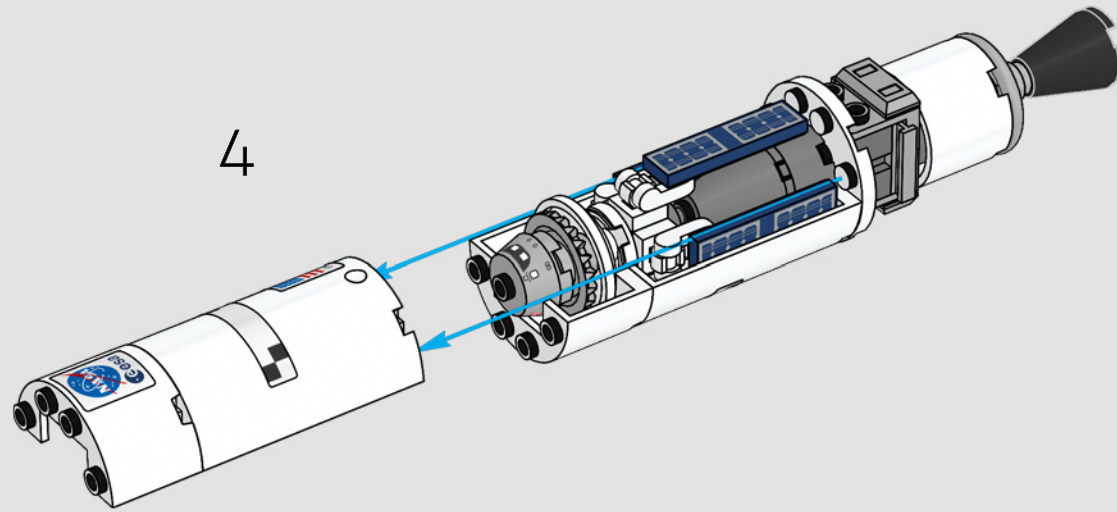

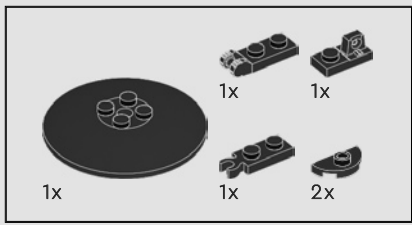

6

1

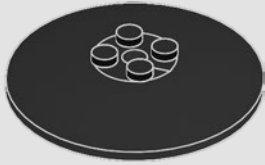

2

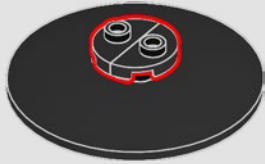

3

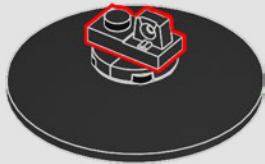

4

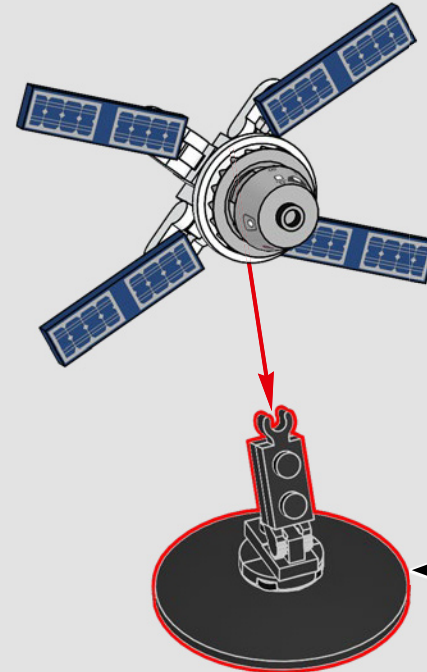
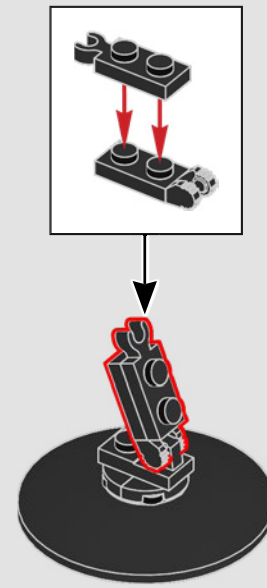

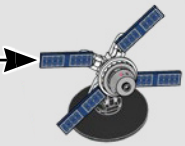
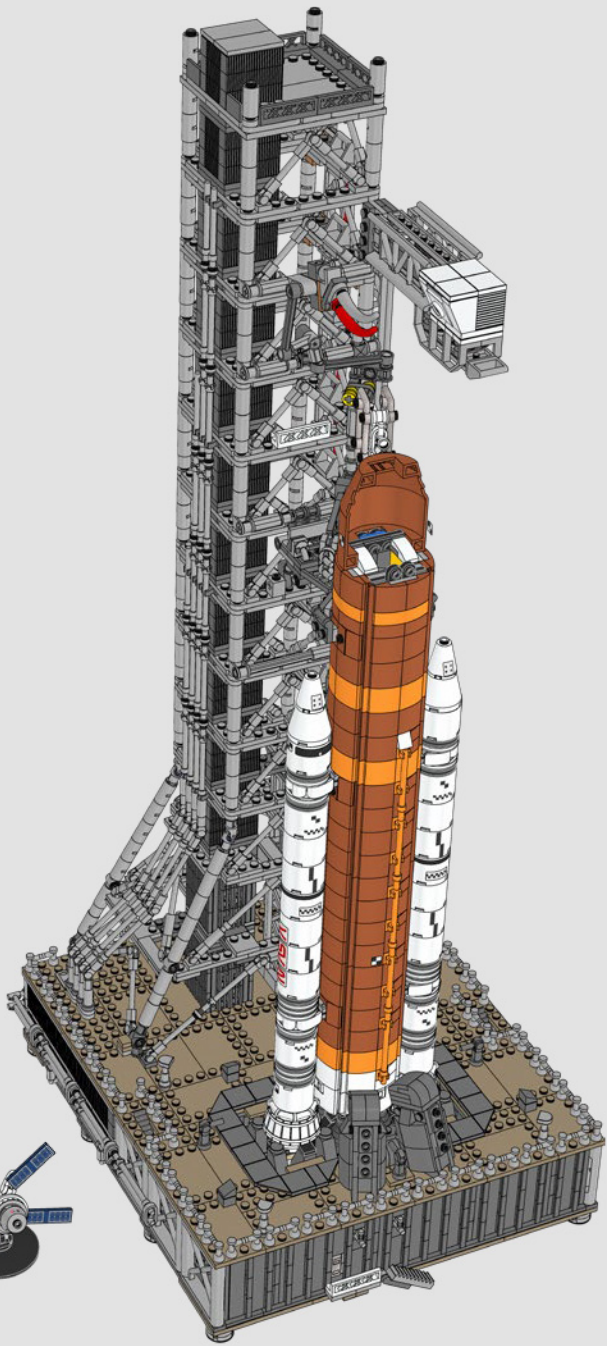

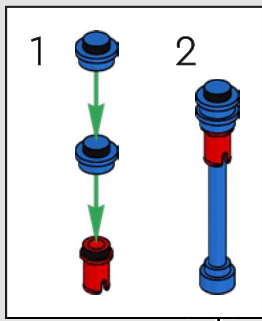
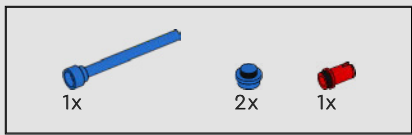

1

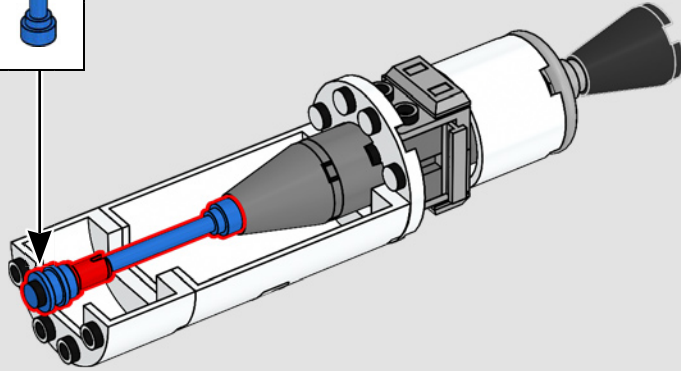

2

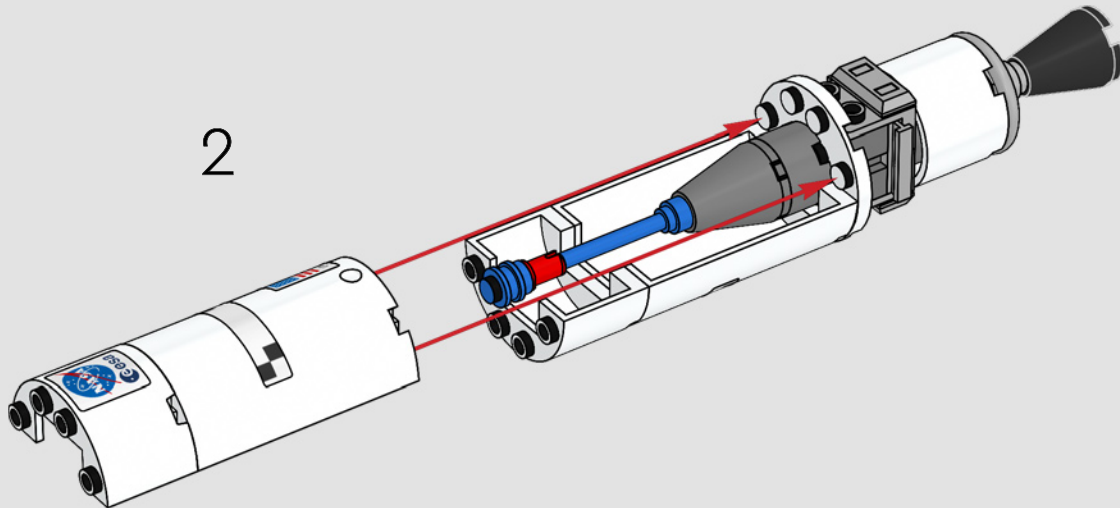

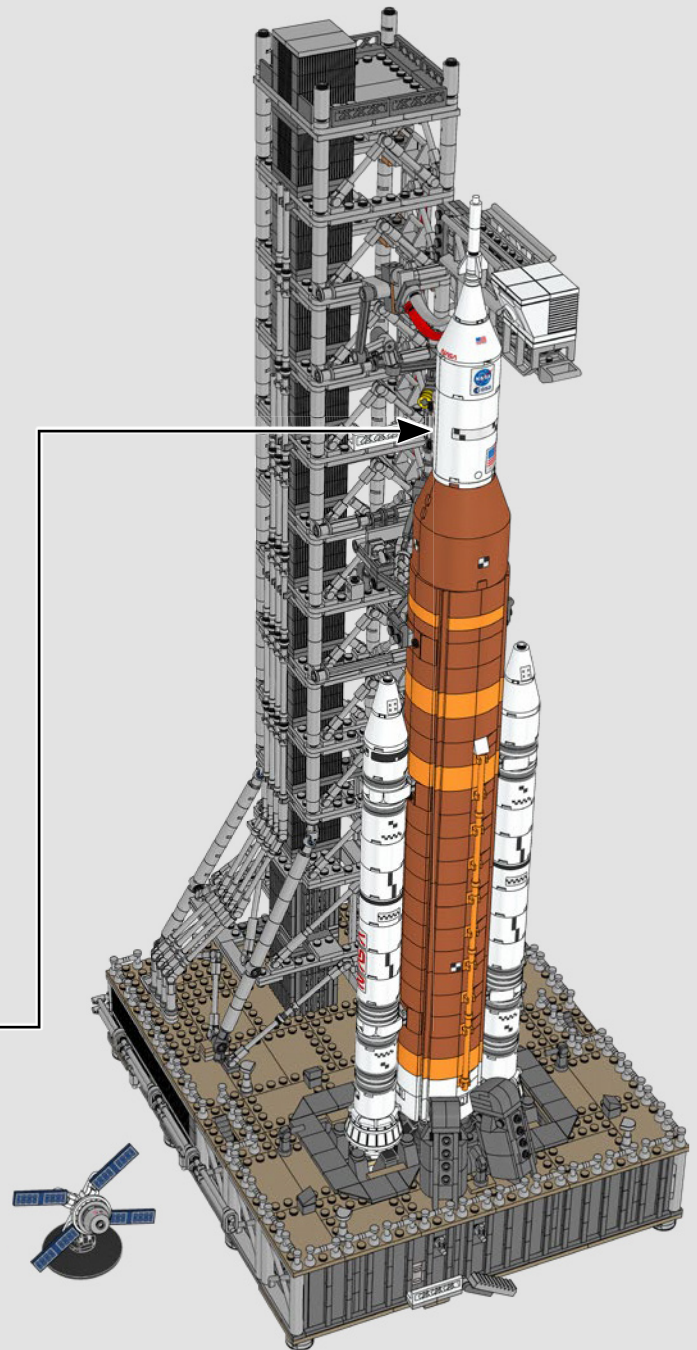
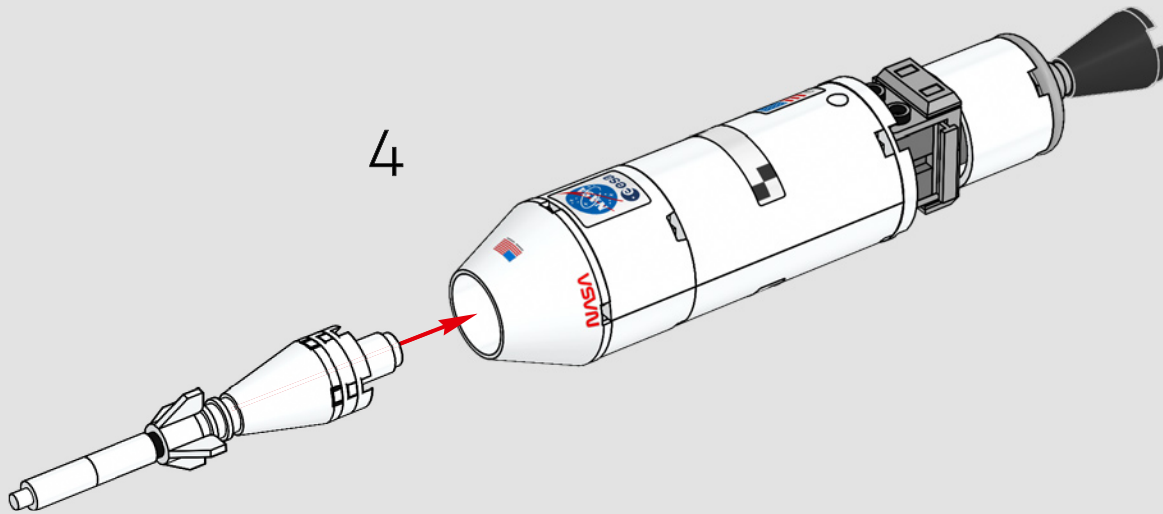
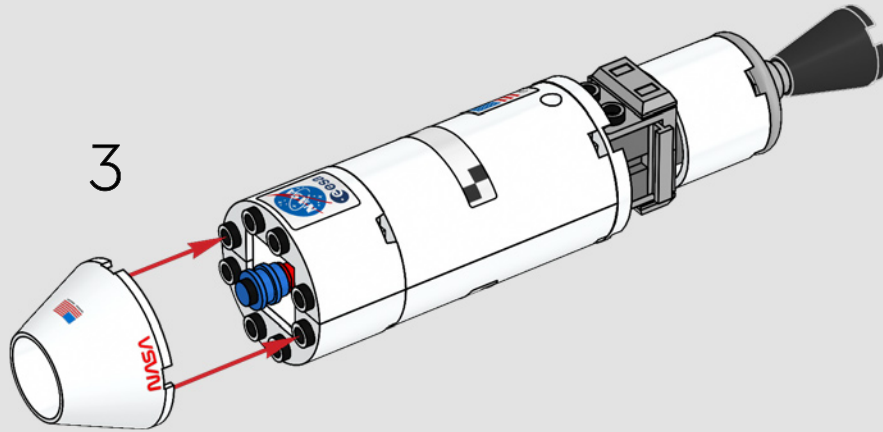

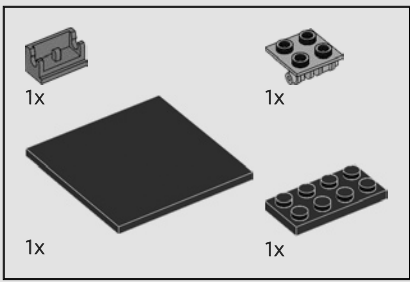

1

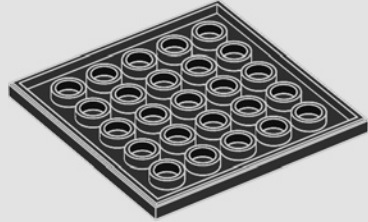

2

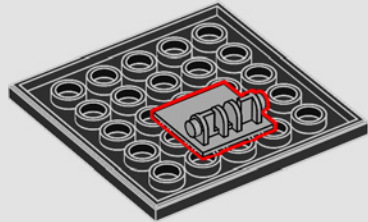

3

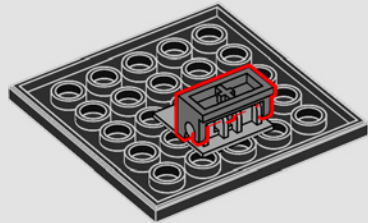

4

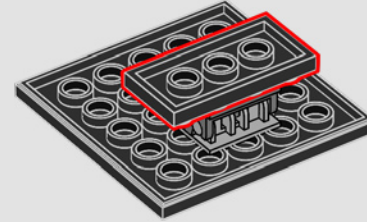

5

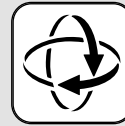
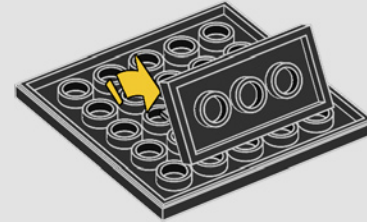

6

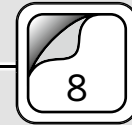
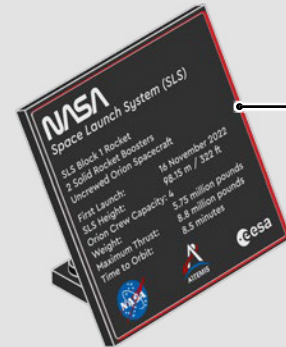

8

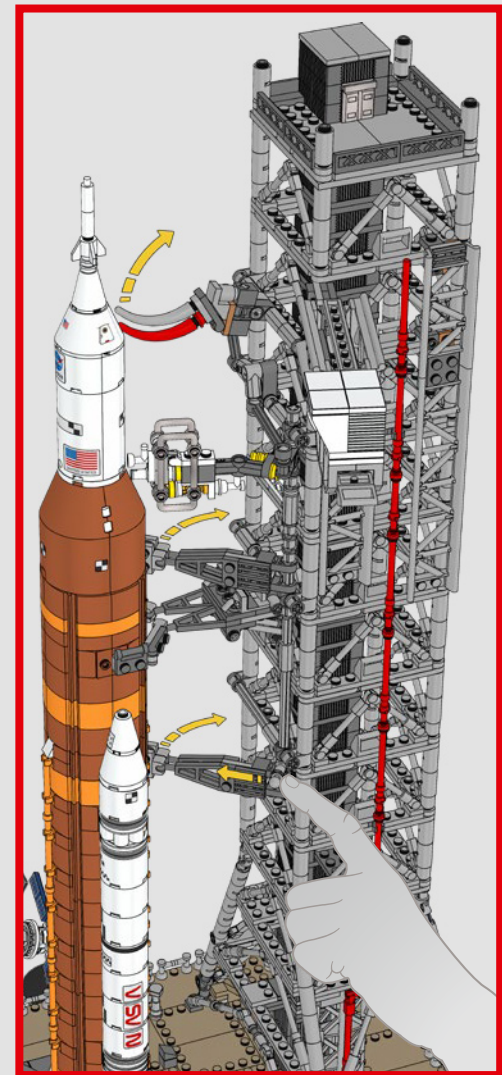
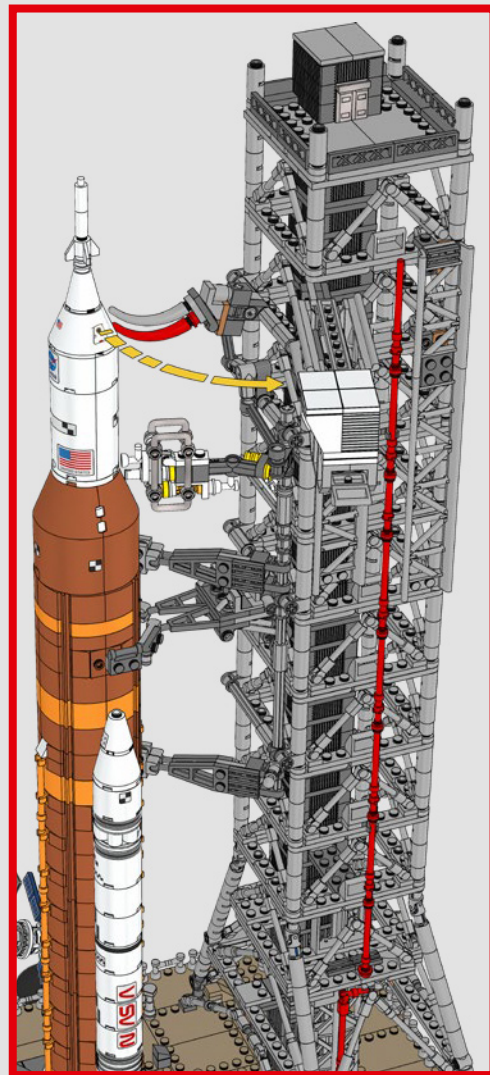
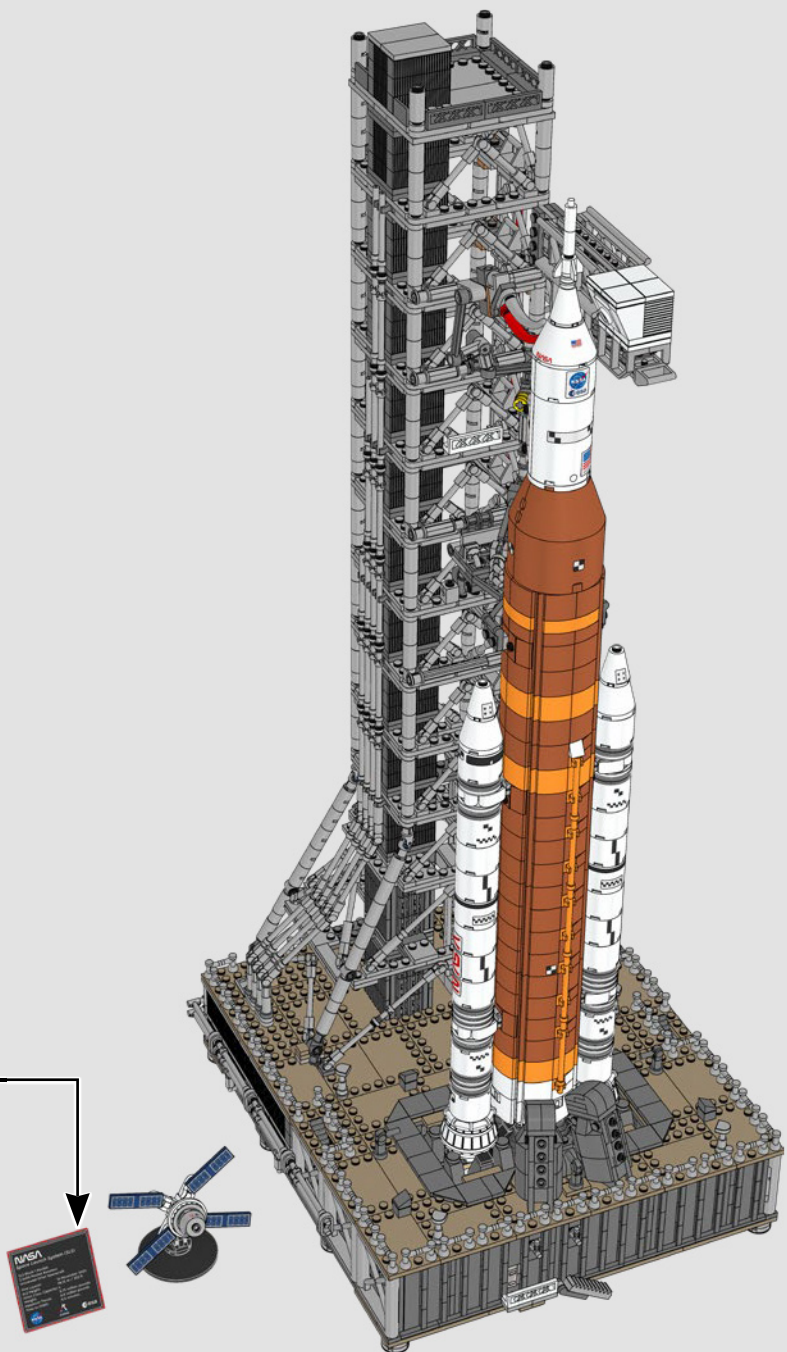

- 2x 6234807
- 7x 614101
- 2x 6168642
- 1x 306201
- 4x 459901
- 1x 6388018
- 11x 6177114
- 2x 300501
- 4x 4504369
- 4x 6348055
- 1x 6442358
- 1x 4111971
- 1x 6331225
- 15x 6210272
- 8x 6434569
- 4x 6174937
- 2x 403201
- 3x 6044601
- 2x 6281990
- 1x 614301
- 1x 6093053
- 5x 6194851
- 5x 287701
- 4x 6173116
- 5x 6210076
- 2x 4515370
- 2x 6166894
- 4x 6034044
- 8x 4249563
- 16x 6330136
- 4x 235701
- 4x 6013866
- 1x 6238334
- 6x 6047220
- 1x 6267044
- 1x 4179580
- 4x 6188466
- 6x 6313593
- 1x 6245249
- 13x 6390507
- 4x 6483019
- 4x 6484829
- 5x 6195371
- 2x 302101
- 2x 6246885
- 2x 6249552
- 2x 6009016
- 2x 4550171
- 1x 4515347
- 1x 6483018
- 4x 6018101
- 2x 6388641
- 2x 4560178
- 5x 4243812
- 17x 379501
- 2x 4113915
- 13x 4114306
- 2x 4121921
- 8x 4118790
- 2x 6223291
- 9x 4166138
- 2x 4249019
- 2x 6093864
- 2x 6330584
- 8x 6231857
- 1x 6341972
- 1x 306221
- 2x 6223427
- 2x 459921
- 4x 6378120
- 2x 6210269
- 1x 6399645
- 2x 4142865
- 5x 302321
- 4x 241221
- 3x 6275080
- 2x 300321
- 12x 300221
- 1x 6129995
- 1x 6431120
- 2x 300121
- 9x 6170487
- 1x 6253828
- 10x 4181138
- 1x 6130004
- 1x 416221
- 1x 383221
- 2x 614123
- 26x 4206482
- 7x 302323
- 10x 6092582
- 32x 6345634
- 5x 6299413
- 2x 6469450
- 1x 302123
- 1x 4166140
- 2x 300123
- 3x 302023
- 2x 6210271
- 2x 302328
- 20x 6104342
- 12x 6188477
- 4x 6092602
- 4x 4570877
- 8x 6186009
- 2x 6440767
- 8x 6228839
- 114x 6104344
- 2x 6394948
- 1x 6219673
- 16x 6472959
- 2x 6381453
- 17x 6240030
- 3x 6271167
- 2x 6284577
- 6x 6119197
- 2x 302324
- 14x 4164073
- 1x 6130008
- 11x 6329869
- 2x 383224
- 4x 6168646
- 4x 307026
- 4x 4504382
- 1x 6344752
- 2x 6438919
- 4x 6371584
- 5x 6024730
- 1x 4653822
- 114x 6279875
- 4x 4109810
- 1x 6092664
- 6x 6143850
- 2x 4253815
- 32x 6092585
- 4x 4121966
- 1x 393826
- 1x 6338799
- 1x 6350725
- 12x 6323668
- 4x 6267045
- 4x 6428167
- 1x 6116604
- 1x 243126
- 12x 6174917
- 1x 302026



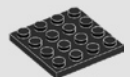

12x  
4243819

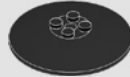

1x  
6058341



3x  
4181144



4x  
373826

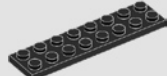

2x  
303426

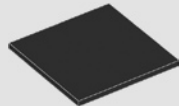

1x  
6155125

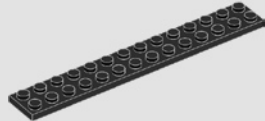

5x  
6001494

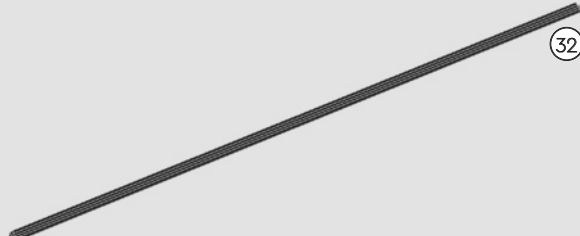

2x  
6210821



20x  
6472962



8x  
4121739



12x  
6021787



24x  
6067913



4x  
4650977



11x  
6472965

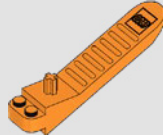

1x  
6240515



8x  
4528604



2x  
6092591



8x  
6335228



2x  
6396392



2x  
6047415



2x  
4550168



4x  
6015452



2x  
6328307



2x  
6257599

32



11x  
4267874



2x  
4550329

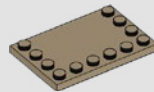

28x  
6472958

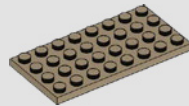

6x  
6006524



6x  
4251796



4x  
6215341



1x  
6134252



48x  
6170418



16x  
6436421



34x  
4539481



36x  
6347715



56x  
6355025



128x  
6343976



2x  
6271165



1x  
4211412



5x  
6258831



8x  
6439041



10x  
6326748



5x  
6250597



9x  
6275844



4x  
6321303



88x  
4211503



33x  
6183784



2x  
4211483



5x  
4211535



4x  
4211476



60x  
6308012



6x  
4211399



2x  
6336539



2x  
4211389



2x  
6362975



2x  
6345639



2x  
4213567



4x  
6443149



26x  
6248890



2x  
4514195



2x  
6225246



8x  
6261375



22x  
6326073



16x  
4211475



2x  
6052200



1x  
6482568



16x  
4211526



10x  
4512360



1x  
6380605



1x  
6268924



104x  
6173127



2x  
4642934



42x  
4211398



6x  
6261353



2x  
6382725



11x  
6134378



11x  
4211357



4x  
6326078



2x  
6435915



1x  
6313114



1x  
6092111



1x  
6123809



2x  
4213378



4x  
6043656



1x  
6265694



20x  
4657366



1x  
4558690



1x  
6004990



2x  
4654580



2x  
4211568



18x  
6446028



19x  
6319336



56x  
6093527



5x  
6212077



2x  
6045988



1x  
4211881



2x  
4211815



2x  
6043639

3

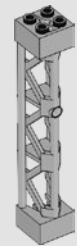

2x  
6186292



1x  
4211655



4x  
6335279



6x  
6438836



4x  
4211429



1x  
4558169



10x  
6211969



1x  
4580510



2x  
6118827



58x  
6456718



19x  
6116608



2x  
4211396



17x  
4211445



7x  
4211356



5x  
6457283



1x  
6257593



6x  
6416524



9x  
4211395



2x  
4560183



2x  
4211639



7x  
6440545



6x  
4565433



1x  
6383116



2x  
4211393



4x  
4211438



2x  
6353802



2x  
6353802



2x  
6353802

5

369

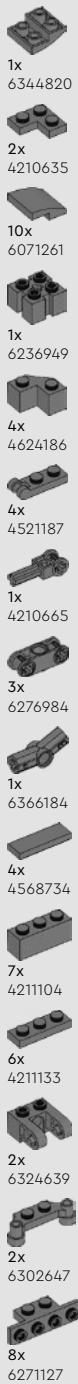
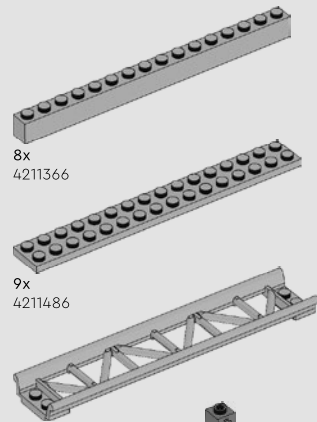
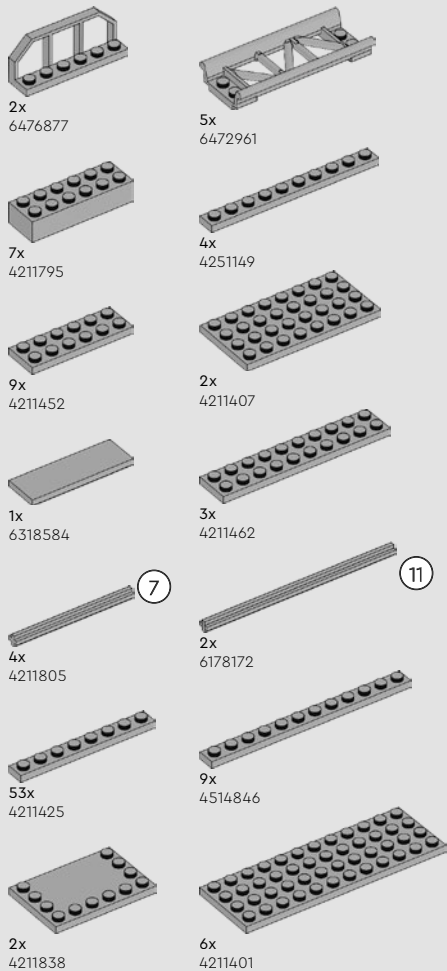

4

7

11



# YOU COULD WIN



## YOU COULD WIN

Your feedback will help shape the future development of this product series.

Visit:

## DU KÖNNTEST GEWINNEN

Dein Feedback trägt zur Weiterentwicklung dieser Produktreihe bei.

Geh auf:

## VOUS POURRIEZ GAGNER

Vos commentaires nous aideront à concevoir les futurs produits de cette gamme.

Visitez :

## POTRESTI VINCERE TU

La tua opinione ci aiuterà a migliorare la creazione futura di questa linea di prodotti.

Visita:

## PUEDES GANAR

Tu opinión contribuirá al futuro de esta serie de productos.

Visita:

## 轻松获奖

您的反馈将有助于我们在今后改进本产品系列。

请访问:

---

**[LEGO.com/productfeedback](https://www.lego.com/productfeedback)**

---

You also have the chance to win a LEGO® set.

Terms and conditions apply.\*

Außerdem hast du die Chance, ein LEGO® Set zu gewinnen.

Es gelten die Teilnahmebedingungen.\*

Vous pourriez également gagner un ensemble LEGO®.

Des conditions s'appliquent.\*

Hai anche la possibilità di vincere un set LEGO®.

Termini e condizioni sono applicabili.\*

También tienes la oportunidad de ganar un set LEGO®.

Aplican términos y condiciones.\*

您还有机会赢取乐高®套装。

条款和条件适用。\*

\*[LEGO.com/productfeedback-terms](https://www.lego.com/productfeedback-terms)

LEGO and the LEGO logo are trademarks of the/sont des marques de commerce du/son marcas registradas de LEGO Group.  
©2024 The LEGO Group. 6551135

NASA Insignia and identifiers provided and used with permission of NASA.

This product is developed in collaboration with the European Space Agency (ESA) for the purpose of fostering children's interest in space science.  
ESA is not involved in the manufacturing and commercialisation of this product.

