

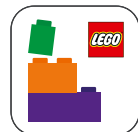

10337



Booklet available in English  
Livret disponible en français  
Folleto disponible en español



Q LEGO® Builder





## WE'RE MAKING OUR PACKAGING MORE SUSTAINABLE

We're transitioning from single-use plastic to paper-based packaging. As we progress, you may find a mix of paper and plastic in our boxes.

## NOUS RENDONS NOS EMBALLAGES PLUS DURABLES

Nous passons des emballages en plastique à usage unique aux emballages à base de papier. Durant la transition, vous pourriez trouver un mélange de papier et de plastique dans nos boîtes.

## QUEREMOS HACER MÁS SUSTENTABLES NUESTROS MATERIALES DE EMBALAJE

Estamos cambiando las bolsas de plástico desechables por bolsas con base de papel. Conforme avanzamos en este propósito, puedes encontrar una mezcla de papel y de plástico en nuestras cajas.

[LEGO.com/sustainable-packaging](https://LEGO.com/sustainable-packaging)





# BUILDER



Apple and the Apple logo are trademarks of Apple Inc., registered in the U.S. and other countries and regions. App Store is a service mark of Apple Inc. Google Play and the Google Play logo are trademarks of Google LLC. Tencent and the Tencent logo are trademarks of Tencent Inc.

LEGO.com/devicecheck



LEGO® Builder

LAMBORGHINI





## Perfect proportions

If you were a teenager in the 1980s, chances are you would recognize the silhouette of the Lamborghini Countach from a mile away. You might even still have a poster of it stashed away somewhere (or proudly on display). With a history spanning more than 50 years, from the first LP500 prototype revealed in 1971 to today, everything about the Countach is disruptive. The strikingly low silhouette with sharp angles and scissor doors, and the exuberant roar of the V-12 engine cemented the Countach as a literal poster child of the 1980s and well into the 1990s and defined the super sports car genre of its time. Its groundbreaking, futuristic design fed right into the zeitgeist and pop culture, and, like a classic work of art, its appeal is timeless. Its story, shape and bright colors made it an indisputable candidate for the LEGO® Icons medium.

## Des proportions parfaites

Si vous étiez adolescent dans les années 1980, il y a de fortes chances que vous reconnaissiez immédiatement la silhouette de la Lamborghini Countach. Il se peut même que vous ayez encore une affiche de la Countach cachée quelque part (ou fièrement exposée). Avec une histoire qui s'étend sur plus de 50 ans, depuis le premier prototype LP500 révélé en 1971 jusqu'à aujourd'hui, la Countach est tout simplement fascinante. Sa silhouette remarquablement basse, ses angles aigus, ses portes « ciseaux » et le rugissement exubérant de son moteur V-12 ont fait de la Countach une véritable tête d'affiche des années 1980 et des années 1990, et ont défini le genre des supervoitures de sport de l'époque. Sa conception révolutionnaire et futuriste s'est inscrite dans l'air du temps et la culture populaire et, comme une œuvre d'art classique, elle reste intemporelle. Son histoire, sa forme et ses couleurs vives en ont fait une candidate incontestable pour la gamme LEGO® Icons.

## Proporciones perfectas

Si tu adolescencia transcurrió en la década de 1980, es muy probable que reconocieras la silueta del Lamborghini Countach a kilómetros de distancia. Incluso es posible que aún tengas un póster de él guardado en alguna parte (o expuesto con orgullo). Con una historia que abarca más de 50 años, desde el primer prototipo del LP500 presentado en 1971 hasta hoy, todo en el Countach es sinónimo de disrupción. Una silueta sorprendentemente baja, el predominio de los ángulos afilados, las puertas de tijera y el exuberante rugido del motor V12 consolidaron al Countach como un ícono absoluto de la década de 1980 y una buena parte de la de 1990, además de definir el género de los autos deportivos para toda una generación. Su diseño pionero y futurista nutrió el espíritu de la época y la cultura popular, y, al igual que el de una obra de arte clásica, su atractivo es atemporal. Su historia, su forma y sus brillantes colores lo convirtieron en un candidato indiscutible para la colección LEGO® Icons.

# The evolution of Lamborghini Countach

Over the decades, the Lamborghini Countach evolved with innovative technology and styles. This LEGO® model is inspired by the Lamborghini Countach 5000 Quattrovalvole (1985-1988), with nods to its distinguished predecessors.



## 1971 LP500

*The prototype revealed at the Geneva Motor Show became the foundation for all future editions.*

## 1971 : LA LP500

*Le prototype révélé au Salon de l'automobile de Genève est devenu la base de toutes les futures versions.*

## 1971 LP500

*El prototipo presentado en el Salón del Automóvil de Ginebra se convirtió en la base de todas las ediciones subsiguientes.*



## 1973 COUNTACH LP400

*Modified based on learnings from the prototype, the LP400 was the first Countach production model.*

## 1973 : LA COUNTACH LP400

*Remaniée sur la base des connaissances tirées du prototype, la LP400 est le premier modèle de production de la Countach.*

## 1973 COUNTACH LP400

*Modificado a partir de los aprendizajes a los que dio lugar el prototipo, el LP400 fue el primer modelo de producción del Countach.*



## 1978 COUNTACH LP400 S

*The updated exterior design included new wheel arch extensions and an optional V-shaped rear wing.*

## 1978 : LA COUNTACH LP400 S

*La nouvelle conception extérieure comprend de nouveaux passages de roues et un aileron arrière en forme de V (en option).*

## 1978 COUNTACH LP400 S

*El diseño actualizado de la carrocería incluía nuevas extensiones de los pasos de rueda y un alerón posterior en V opcional.*



# L'évolution de la Lamborghini Countach

Au fil des décennies, la Lamborghini Countach a connu des innovations technologiques et stylistiques. Ce modèle LEGO® s'inspire de la Lamborghini Countach 5000 Quattrovalvole (1985-1988) et évoque ses distingués prédécesseurs.



## 1983 COUNTACH LP500 S

*While the exterior design remained largely unchanged, the interior was revamped, and a more powerful engine enhanced performance.*

## 1983 : LA COUNTACH LP500 S

*Si la conception extérieure est restée largement inchangée, l'intérieur a été revu et le moteur plus puissant permet d'améliorer les performances.*

## 1983 COUNTACH LP500 S

*Aunque el diseño exterior permaneció prácticamente inalterado, se renovó el interior y se mejoraron las prestaciones con un motor más potente.*

# La evolución del Lamborghini Countach

A lo largo de las décadas, el Lamborghini Countach evolucionó con tecnología y estilos innovadores. Este modelo LEGO® está inspirado en el Lamborghini Countach 5000 Quattrovalvole (1985-1988) e incluye referencias a sus distinguidos predecesores.



## 1985 COUNTACH 5000 QUATTROVALVOLE

*The best-selling Lamborghini Countach in both the US and Europe and a coveted gem for super sports car enthusiasts.*

## 1985 : LA COUNTACH 5000 QUATTROVALVOLE

*Convoitée par les amateurs de supervoitures de sport, cette version est la Lamborghini Countach la plus vendue aux États-Unis et en Europe.*

## 1985 COUNTACH 5000 QUATTROVALVOLE

*El Lamborghini Countach más vendido tanto en EE. UU. como en Europa y una codiciada joya para los entusiastas de los autos superdeportivos.*



## 2021 COUNTACH LPI 800-4

*A hybrid-electric, limited edition released for the Countach 50<sup>th</sup> anniversary.*

## 2021 LA COUNTACH LPI 800-4

*Une édition limitée hybride électrique lancée à l'occasion du 50<sup>e</sup> anniversaire de la Countach.*

## 2021 COUNTACH LPI 800-4

*Una edición limitada híbrida con asistencia eléctrica lanzada con motivo del 50 aniversario del Countach.*







## From the LEGO® Design Team

"This magical aura around the Lamborghini Countach still persists among car enthusiasts today, making it a perfect match for a LEGO® model. While straight lines seem like a natural form for LEGO elements, shallow angles are some of the most challenging shaping tasks to accomplish with our building system. We developed several new elements and advanced building techniques for this model, including the iconic deep dished rims and wheel arches to recreate the characteristic subtle angles, shapes and proportions of this futuristic Italian design. It was an exhilarating ride working with Automobili Lamborghini S.p.A. to bring this model to life in LEGO form, complete with working steering, opening doors and hood."

**SVEN FRANIC,**  
*LEGO® Senior Model Designer*

## Un mot de l'équipe de conception LEGO®

« L'aura magique qui entoure la Lamborghini Countach persiste encore aujourd'hui dans le cœur des passionnés de voitures, ce qui en fait un modèle LEGO® parfait. Bien que les lignes droites semblent être une forme naturelle pour les éléments LEGO, les angles peu profonds sont assez difficiles à rendre avec notre système de construction. Nous avons développé de nouveaux éléments et de nouvelles techniques de construction pour ce modèle, notamment les jantes et les passages de roue emblématiques, afin de recréer les angles délicats, les formes et les proportions caractéristiques de cette conception italienne futuriste. Travailler avec Automobili Lamborghini S.p.A. pour donner vie à ce modèle sous forme LEGO, avec sa direction fonctionnelle ainsi que ses portes et son capot qui s'ouvrent, a été une expérience formidable. »

**SVEN FRANIC,**  
*concepteur principal de modèle LEGO®*

## Impresiones del equipo de diseño de LEGO®

"El halo de magia que envuelve al Lamborghini Countach aún persiste entre los entusiastas de los autos de hoy en día, y eso es precisamente lo que nos impulsó a convertirlo en un modelo LEGO®. Si bien las líneas rectas son algo natural en el mundo de los elementos LEGO, recrear ángulos poco pronunciados es una de las tareas de modelado más difíciles de realizar con nuestro sistema de construcción. Dar vida a este modelo nos llevó a desarrollar técnicas de construcción avanzadas y nuevos elementos, como los emblemáticos rines y los pasos de rueda abombados. Con ello, logramos recrear los sutiles ángulos, las formas y las proporciones que caracterizan a este futurista diseño italiano. Trabajar hombro con hombro con Automobili Lamborghini S.p.A. para dar vida a este modelo con dirección, puertas y cofre funcionales en formato LEGO fue un viaje increíblemente emocionante".

**SVEN FRANIC,**  
*Modelista sénior de LEGO®*

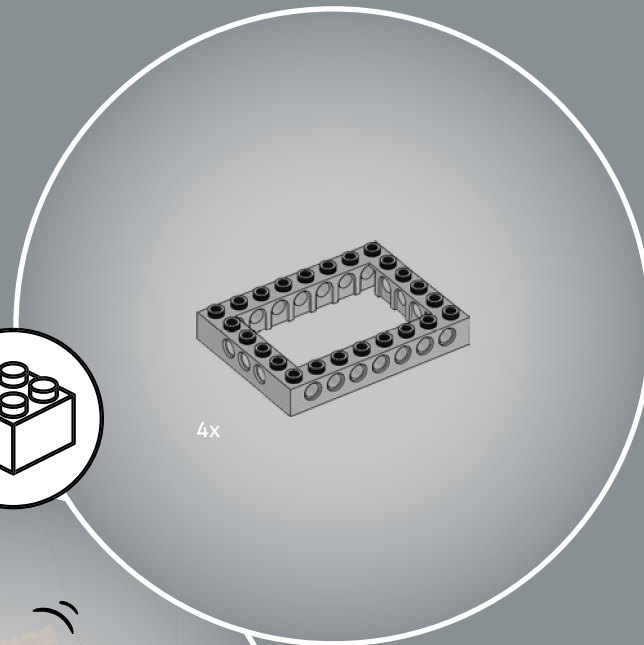
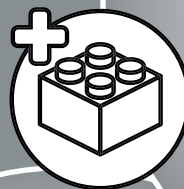
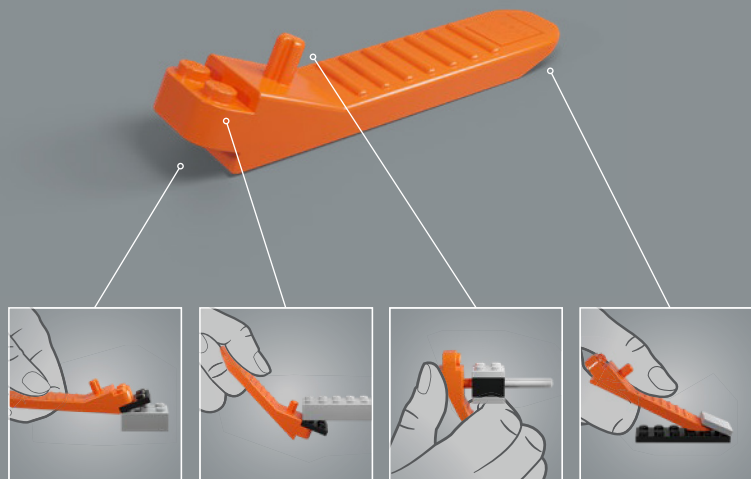



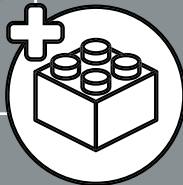
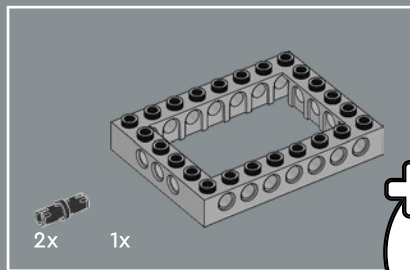

1

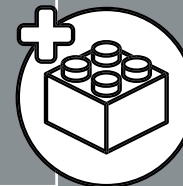
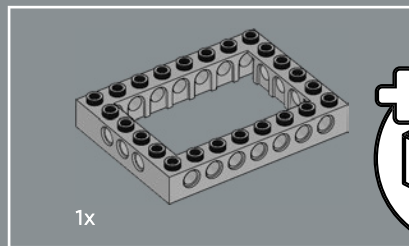
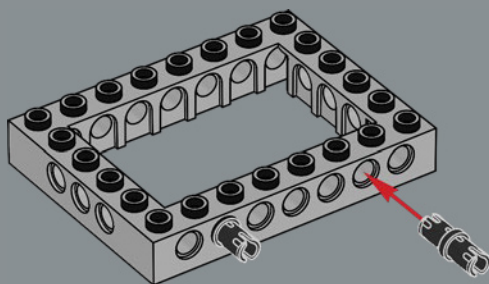

2

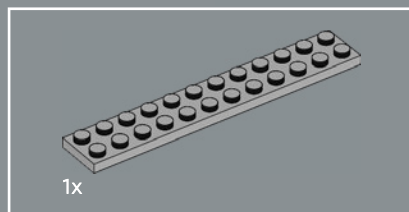
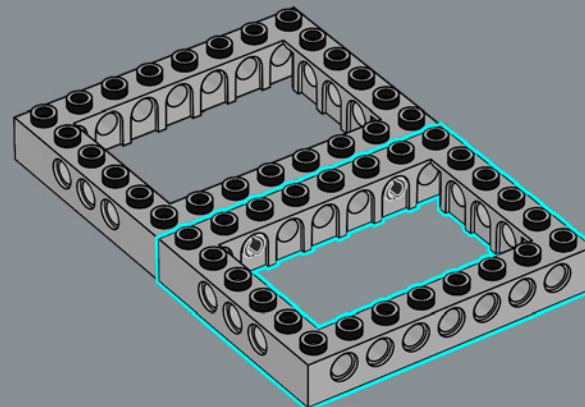

3

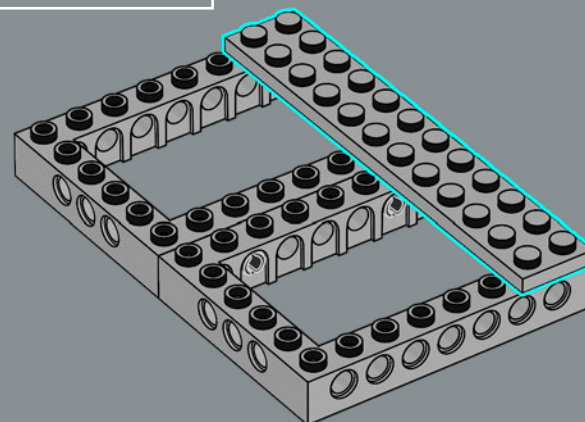

6x

4

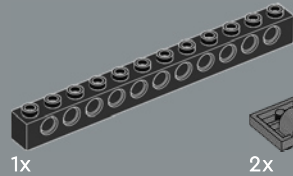
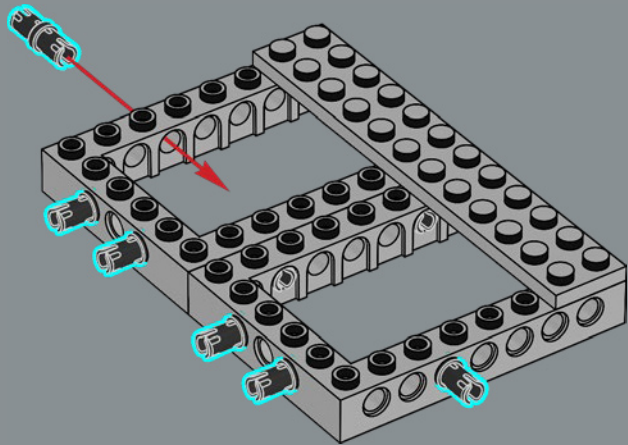

1x

2x

5

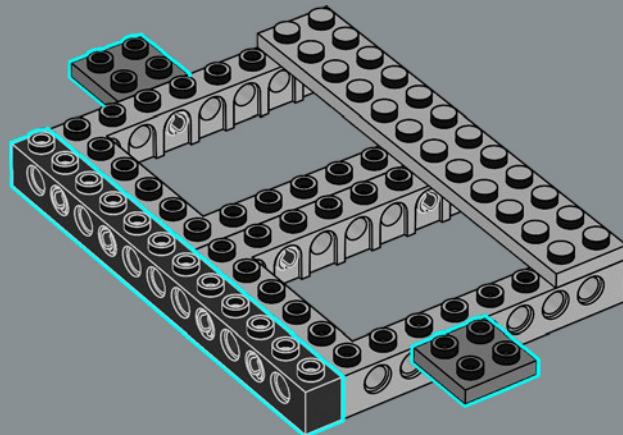

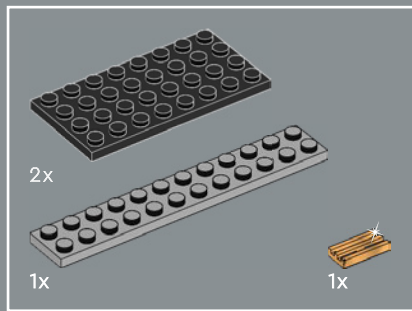

6

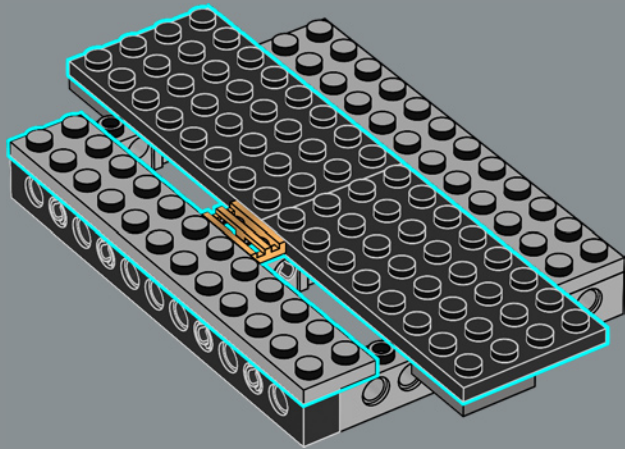

7

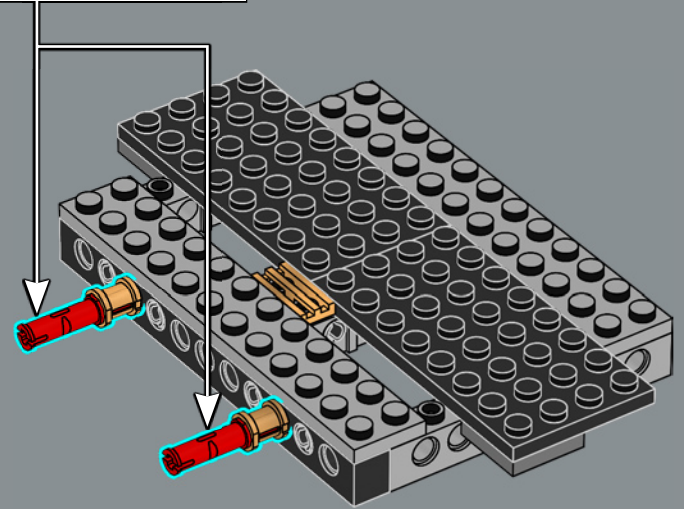
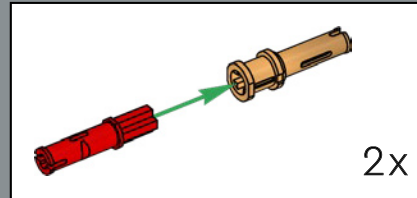

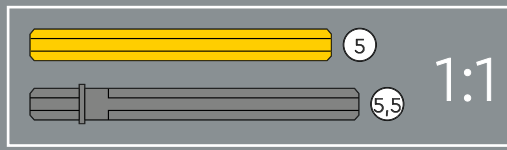
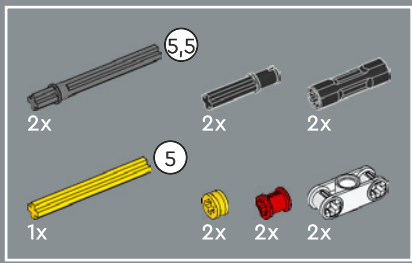

8

1

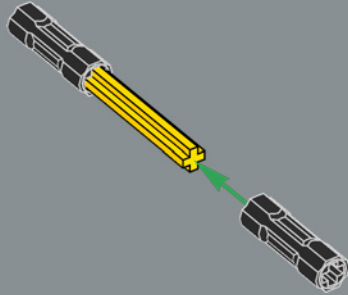

2

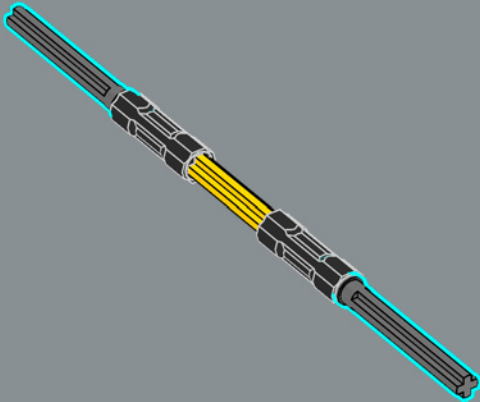

3

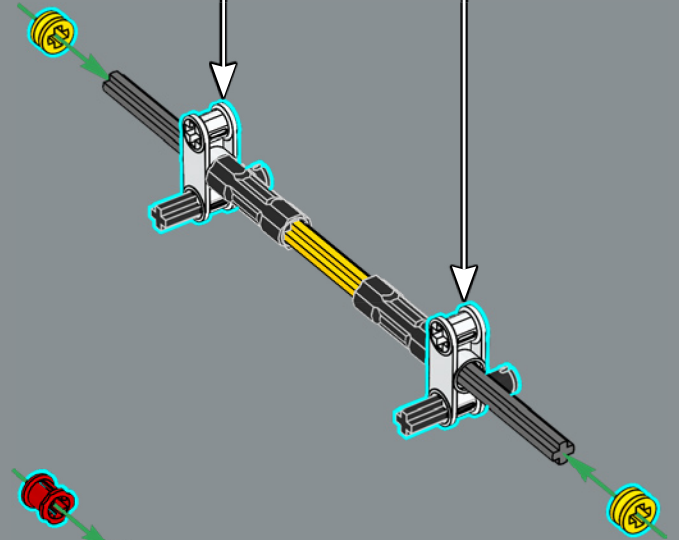

4

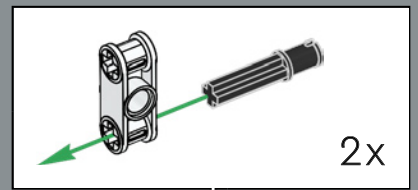
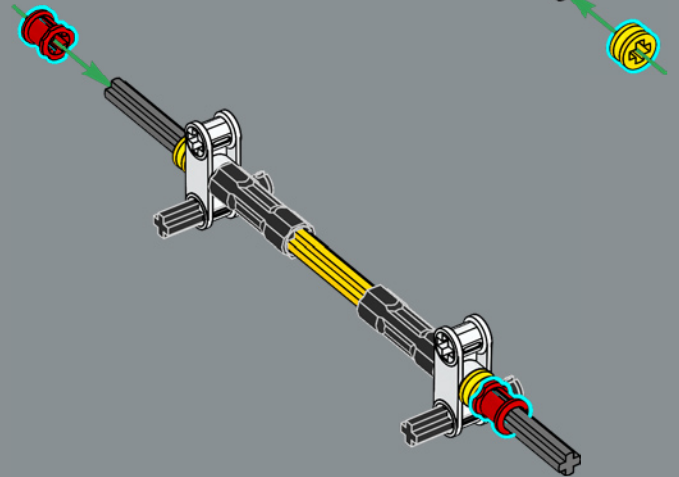

2x





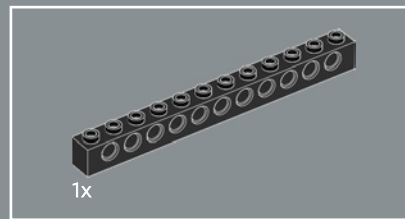
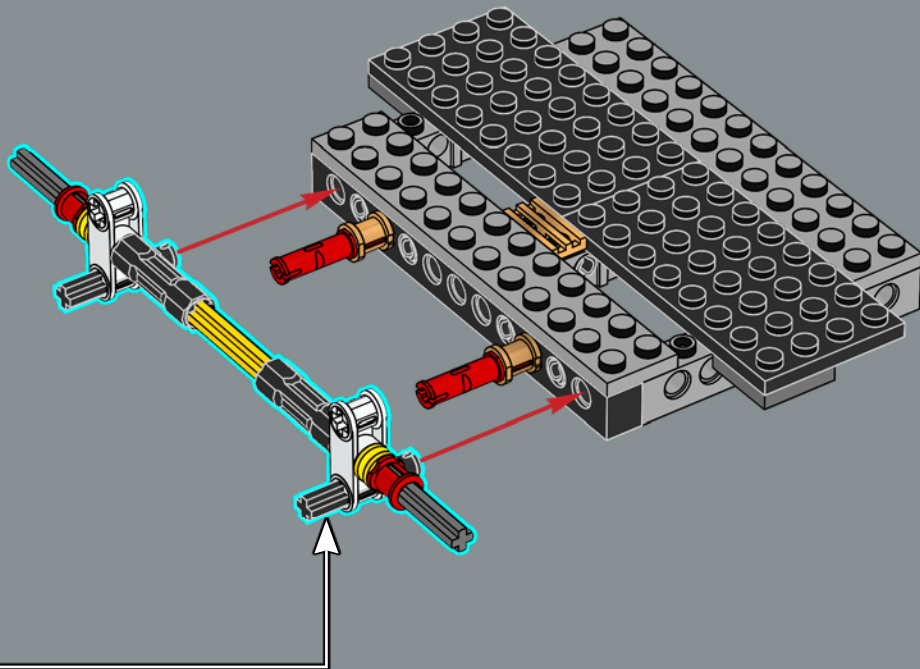

9

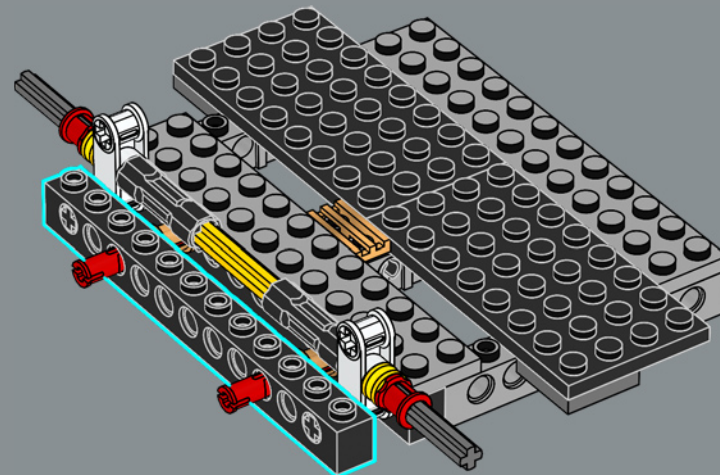



10

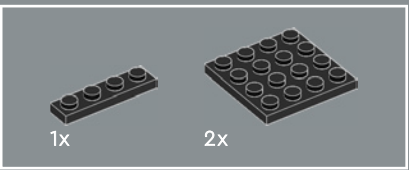
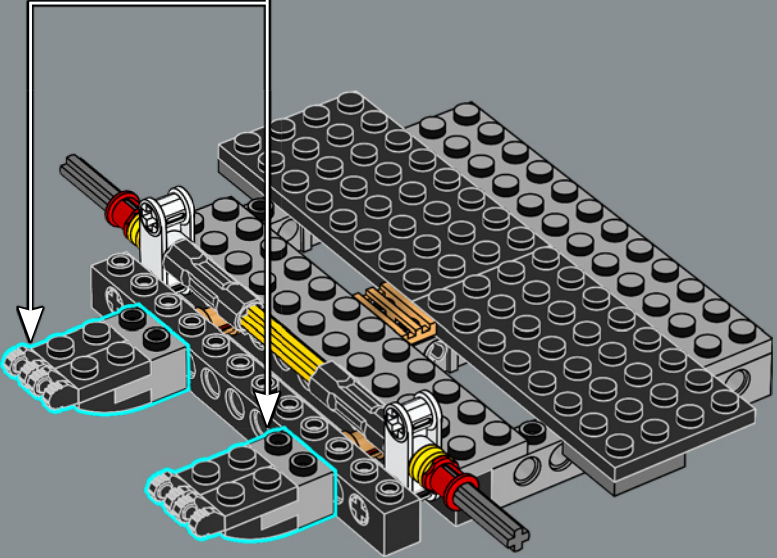
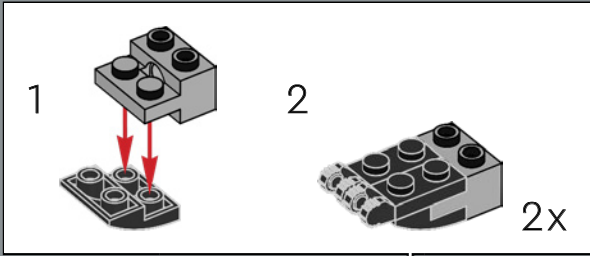

11

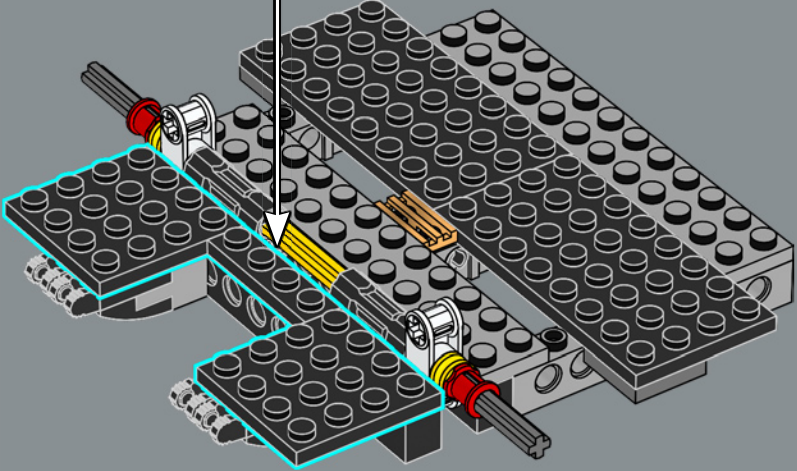
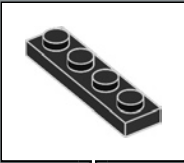

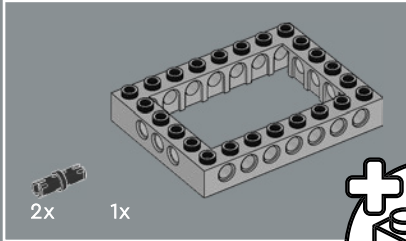
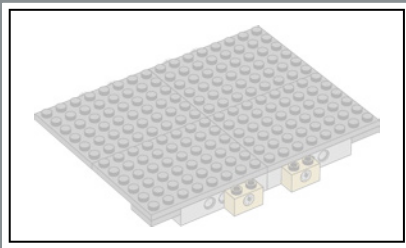

12

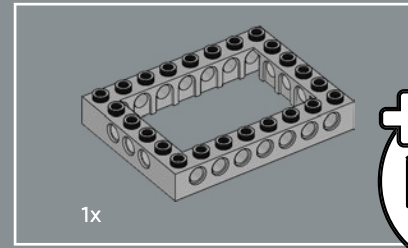
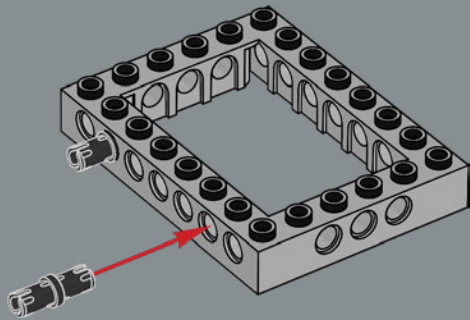

13

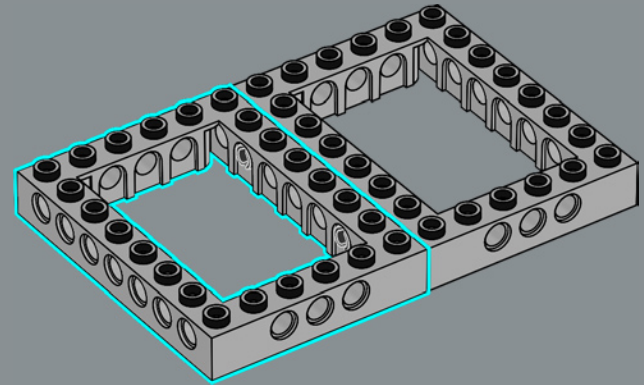

14

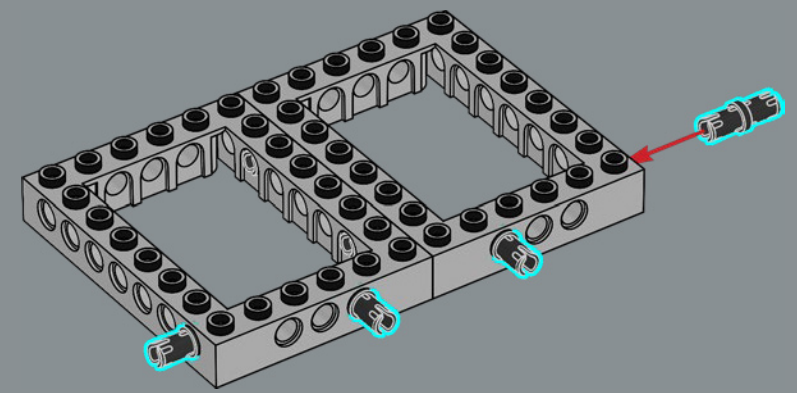

4x

15

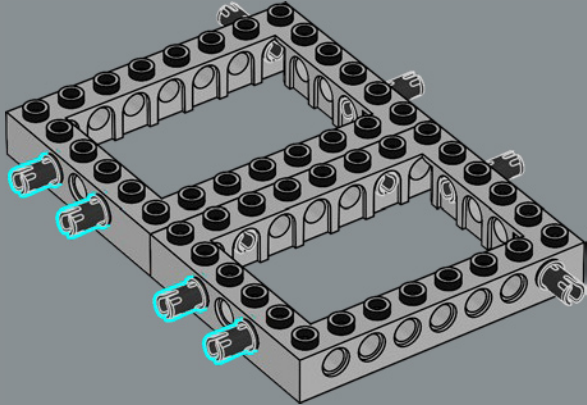

2x

16

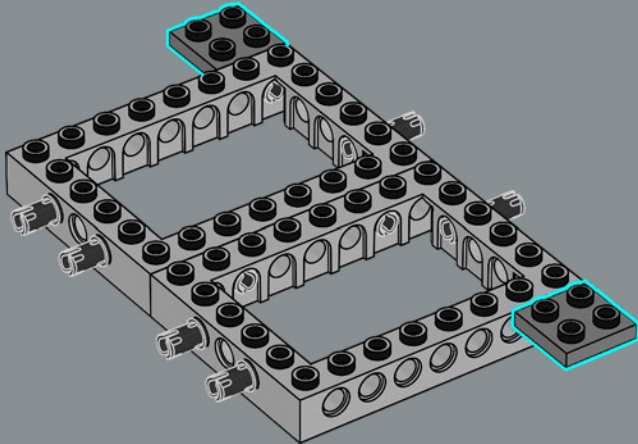

2x

17

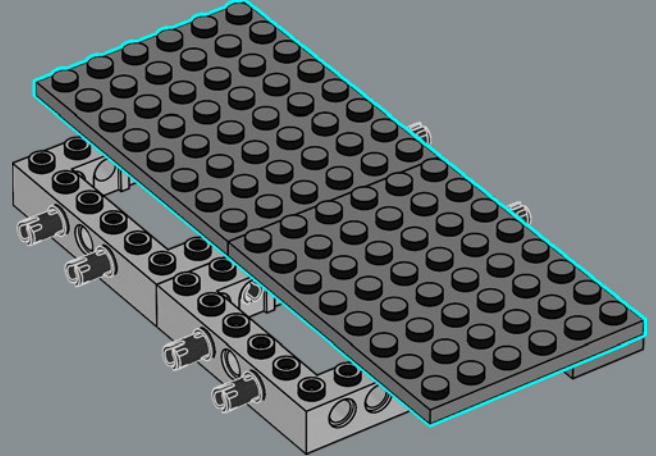

2x

18

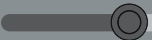
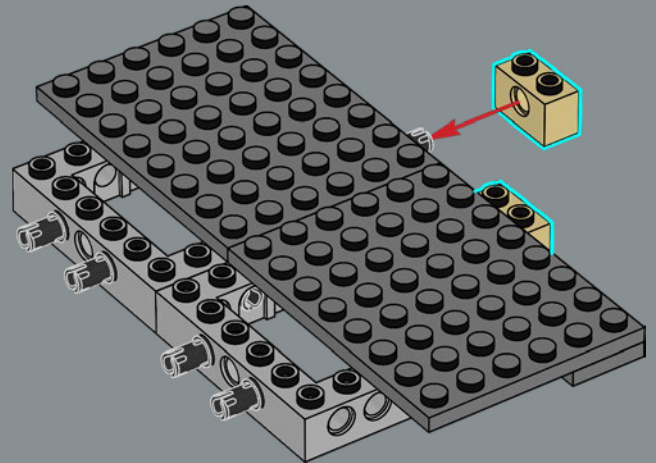



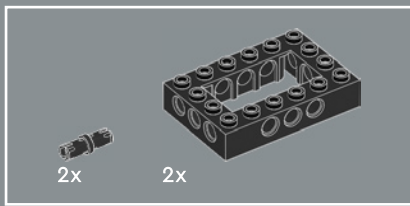

19

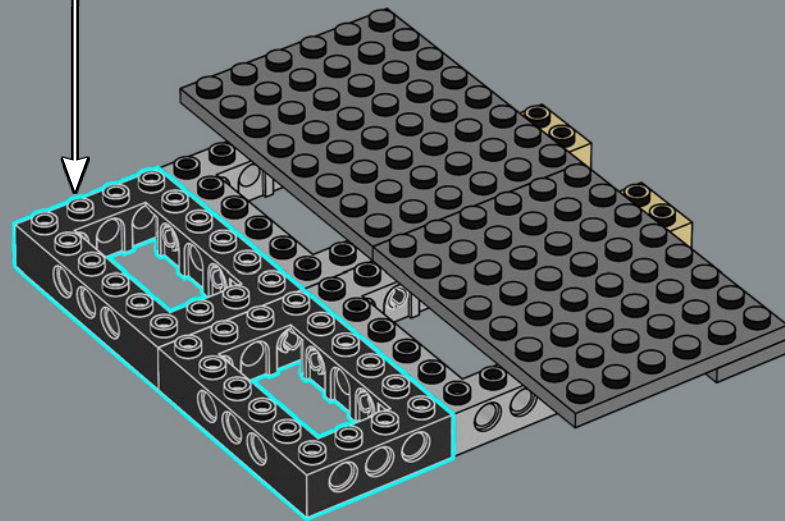
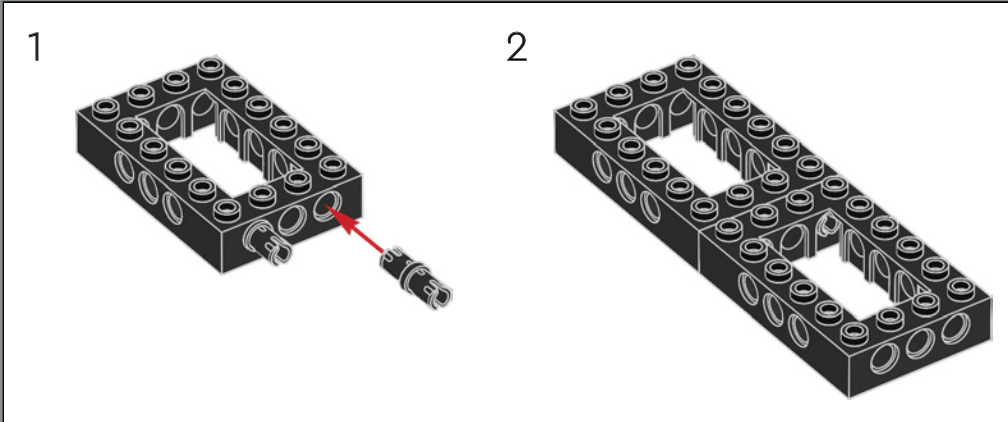

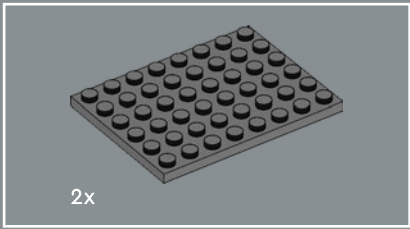

20

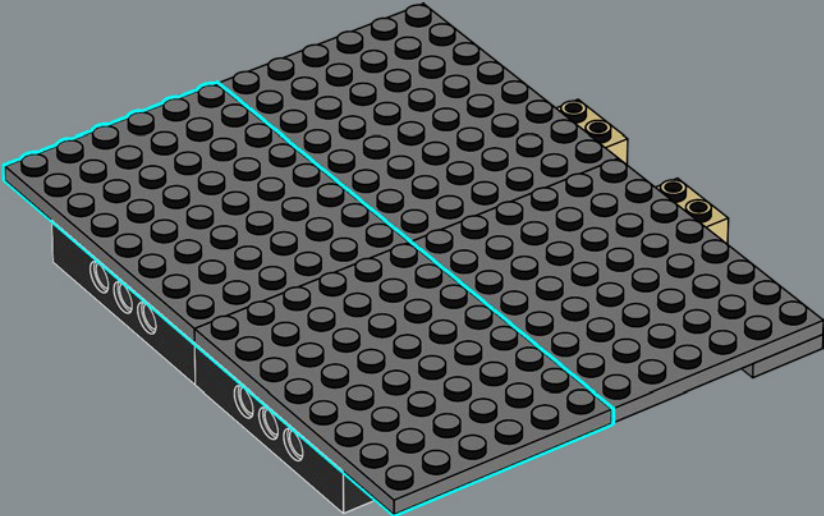

21

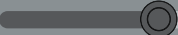
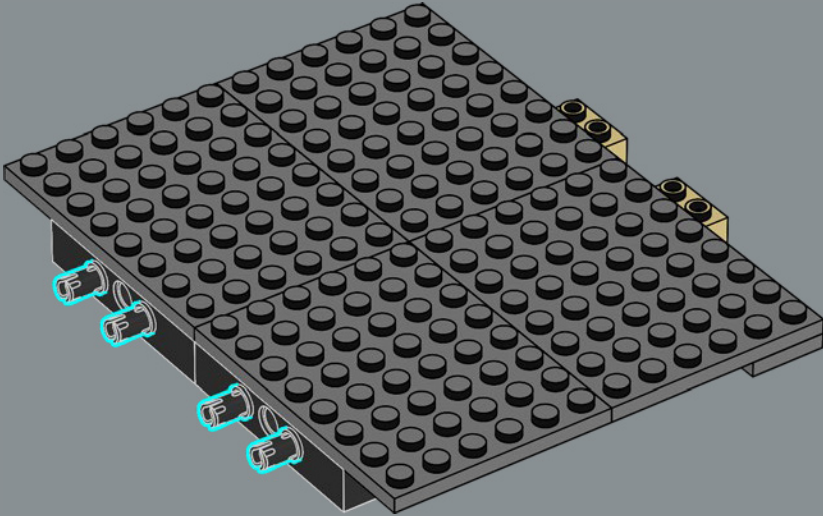



The Lamborghini Countach is known for memorable appearances in classic TV series and major blockbuster movies throughout the 1980s.

La Lamborghini Countach est connue pour ses apparitions mémorables dans les séries télévisées classiques et les grands films à succès des années 1980.

El Lamborghini Countach es conocido por sus memorables apariciones en series para televisión clásicas y grandes éxitos de taquilla de los años 80.

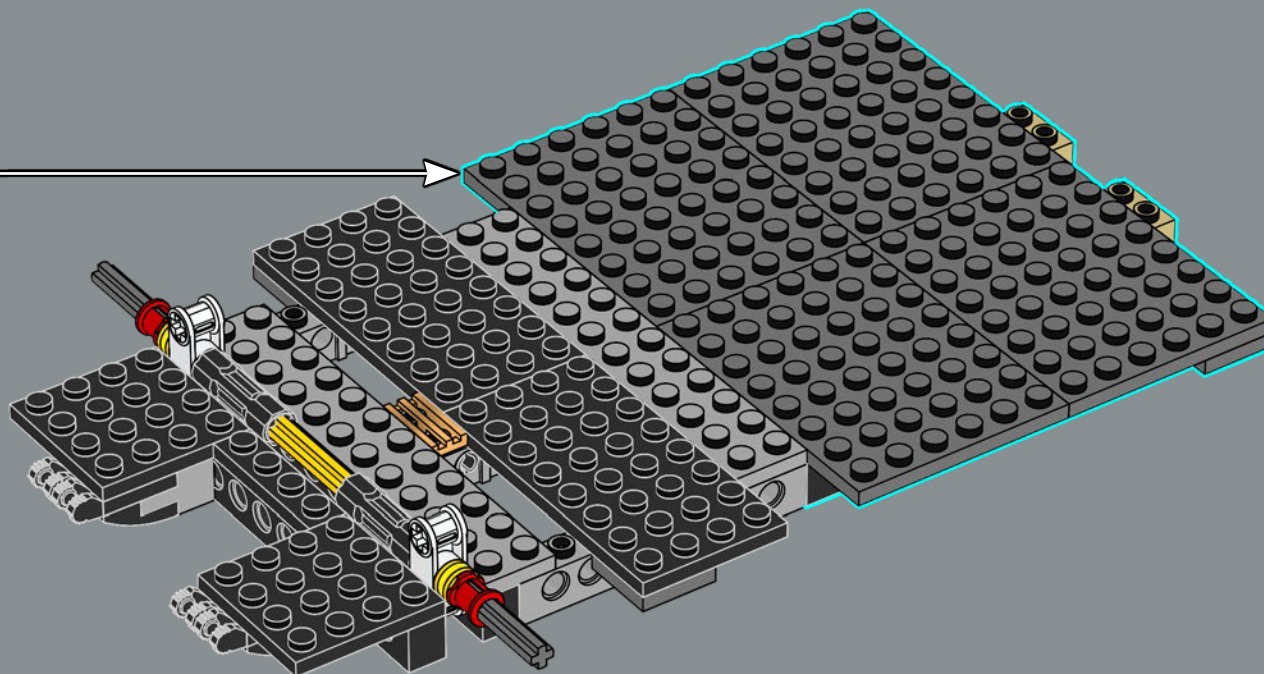



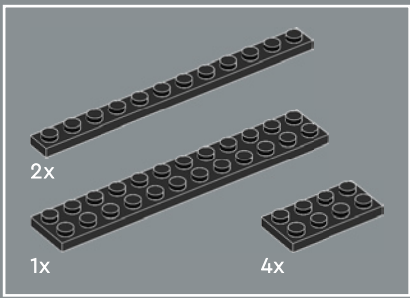

23

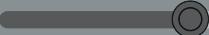
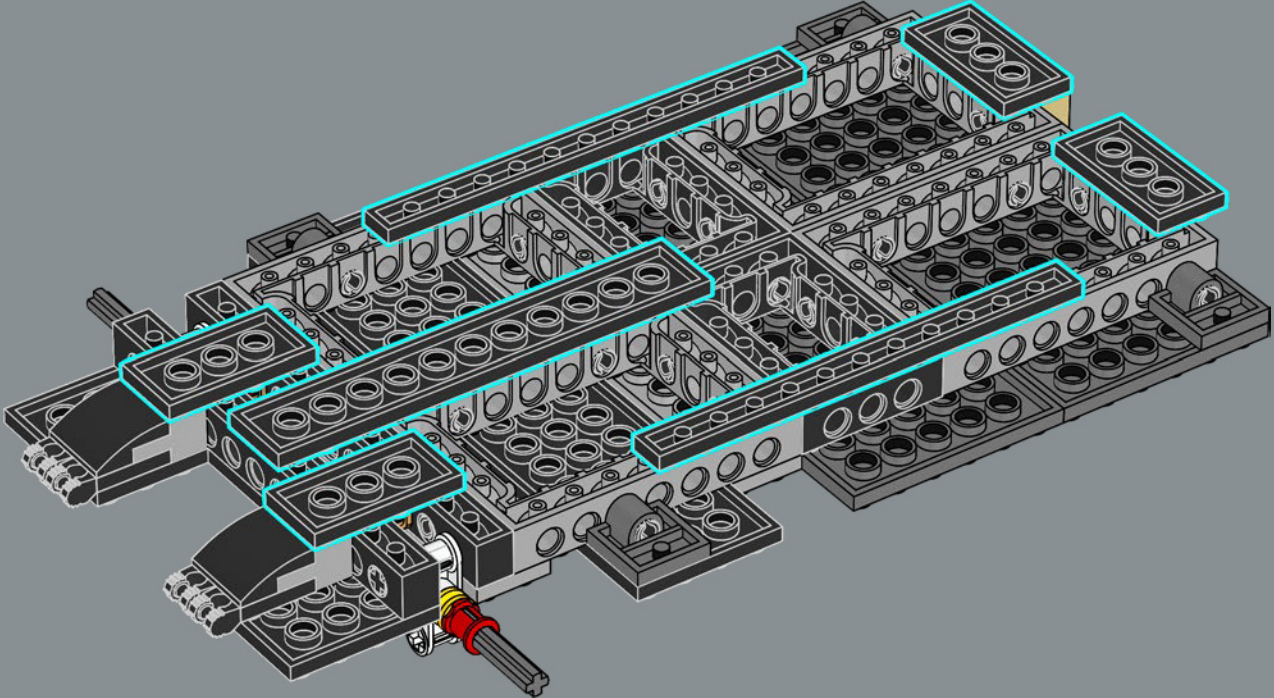

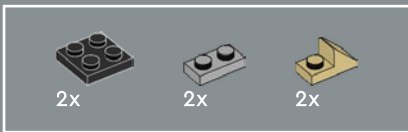

24

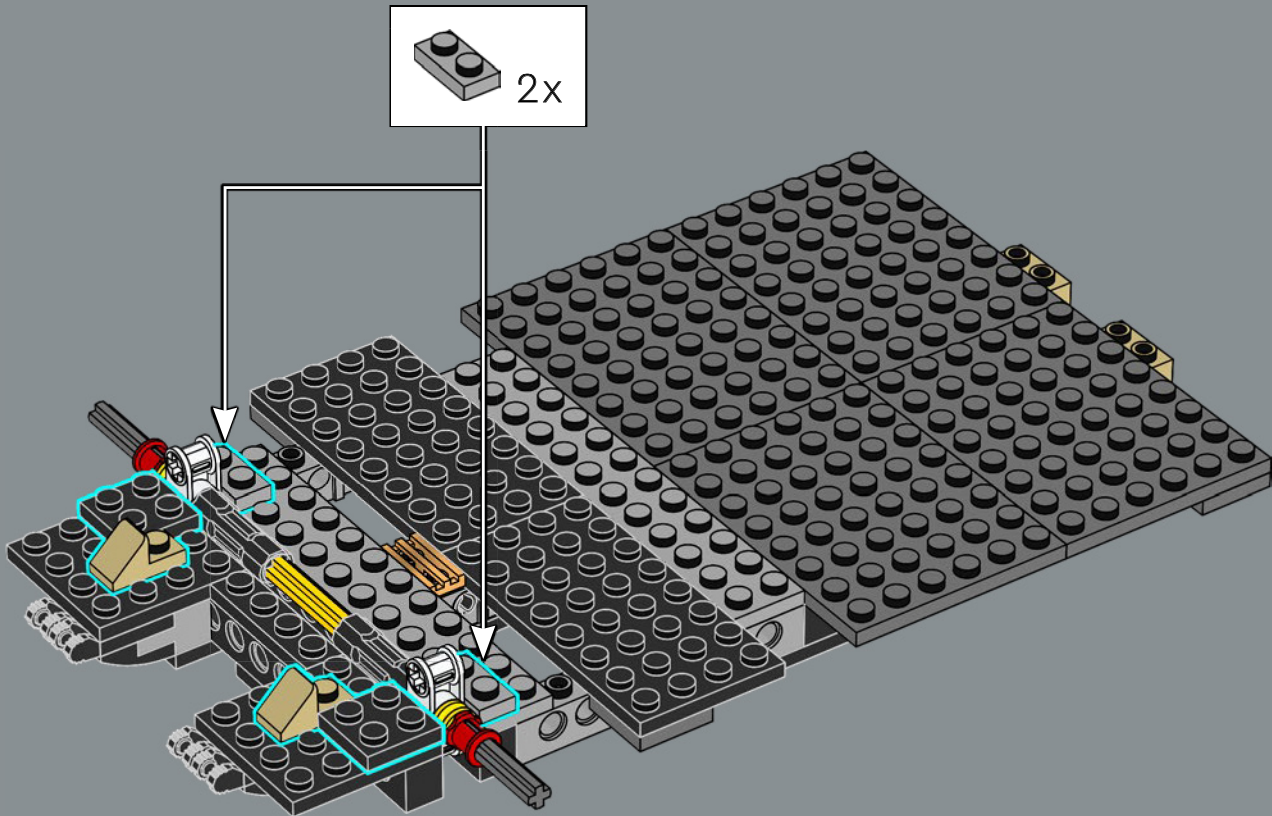

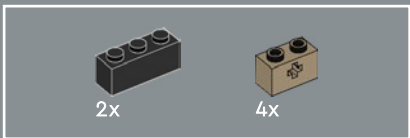

25

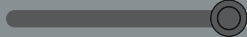
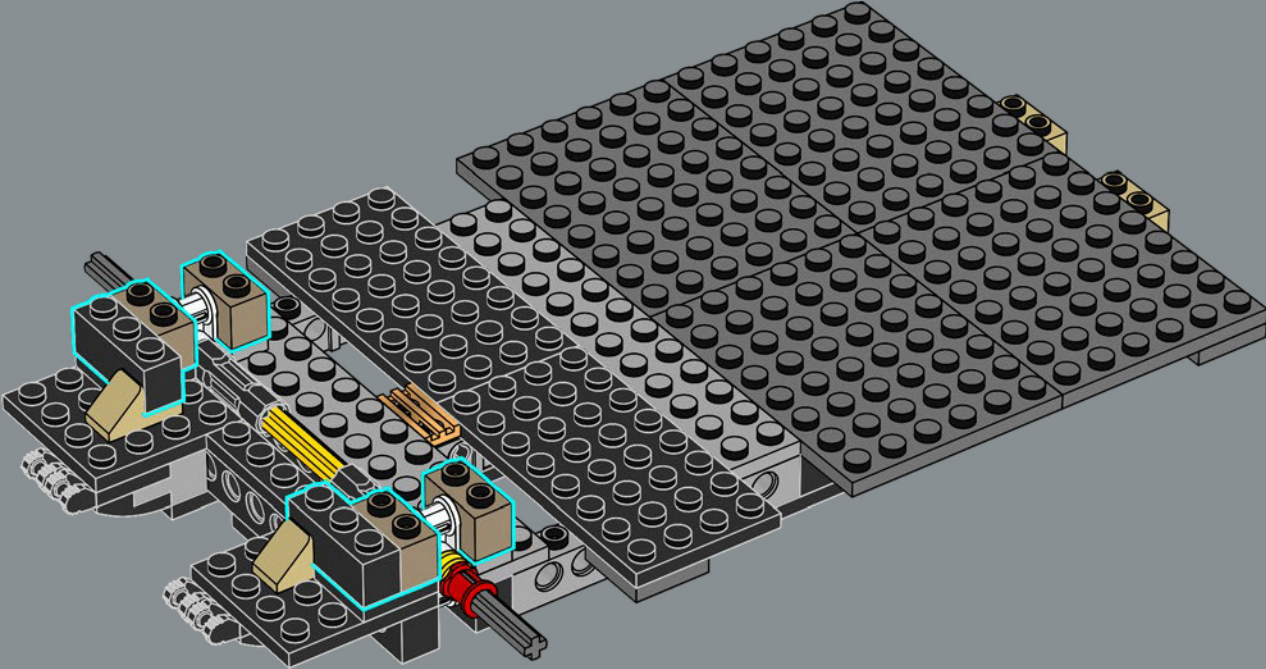



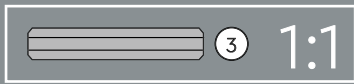
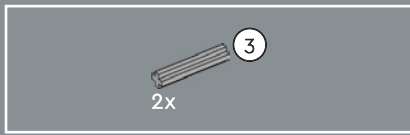

26

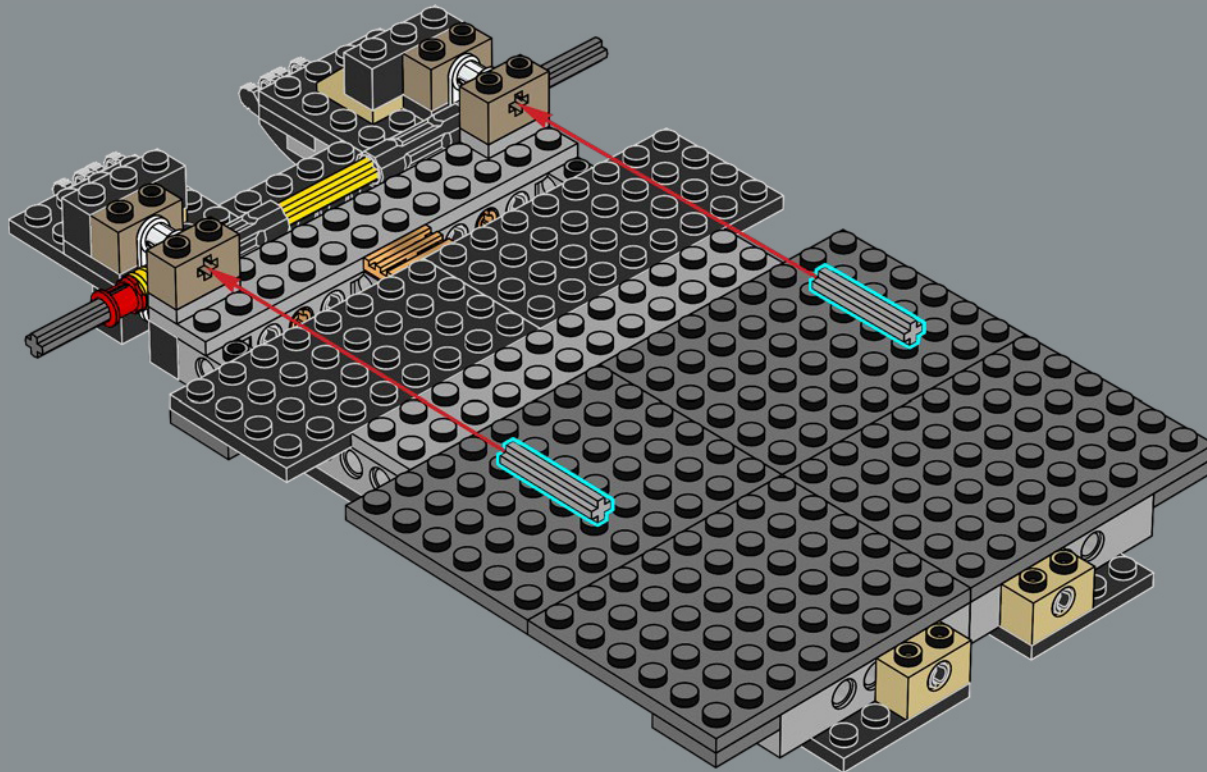

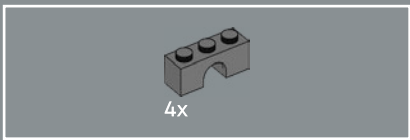

27

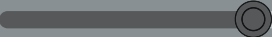
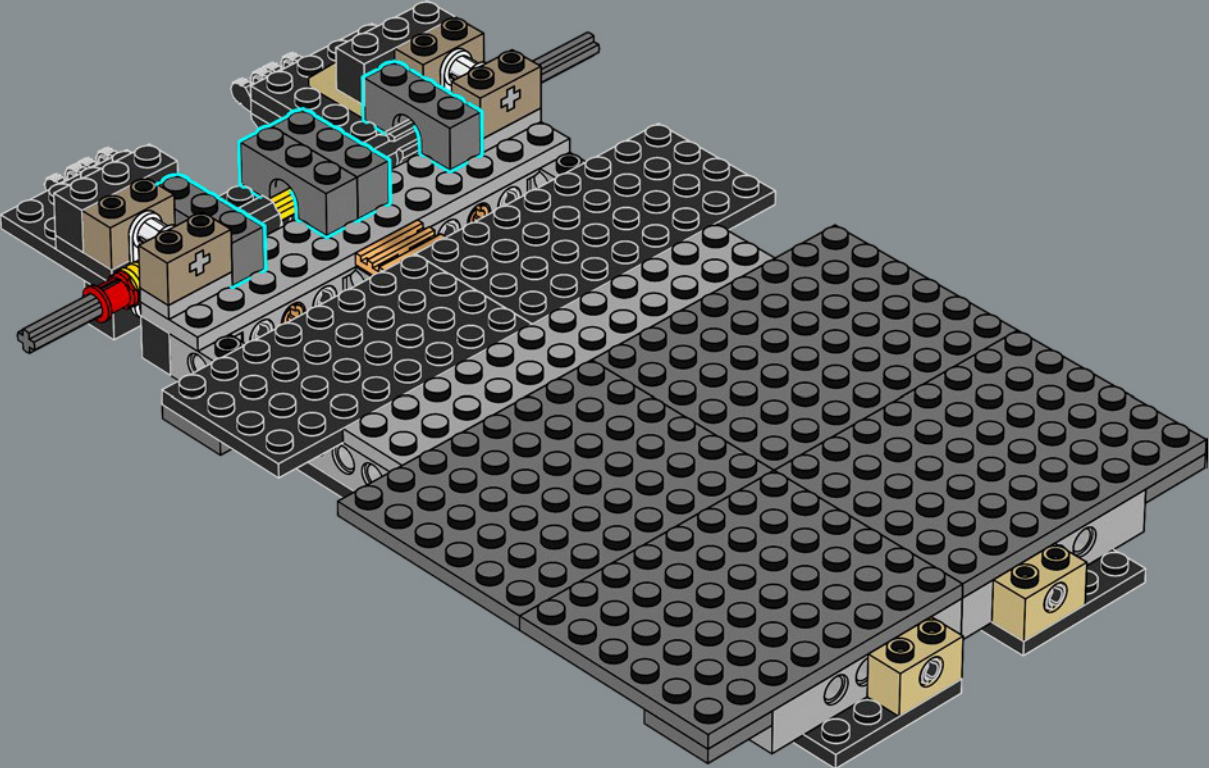

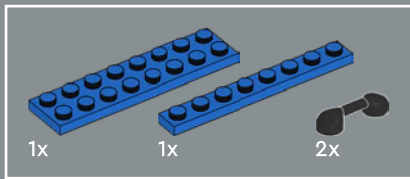

28

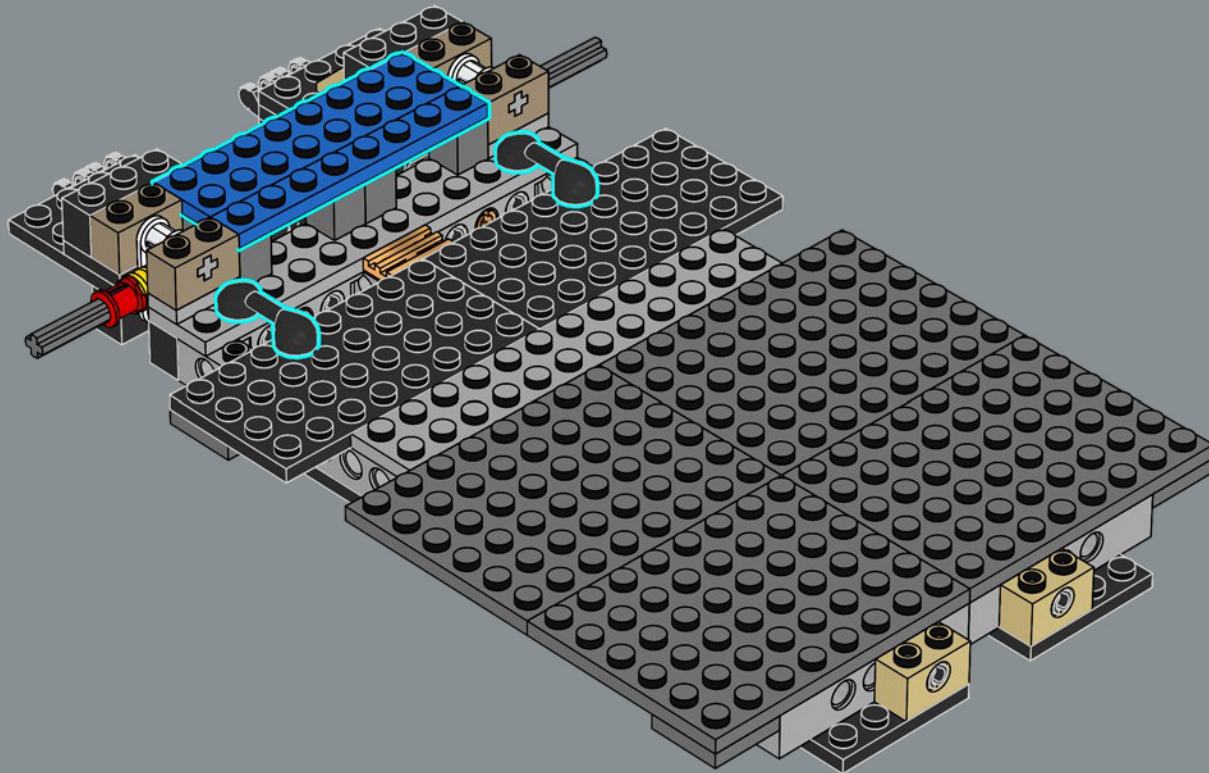

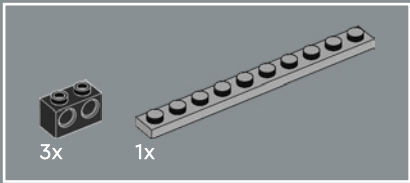

29

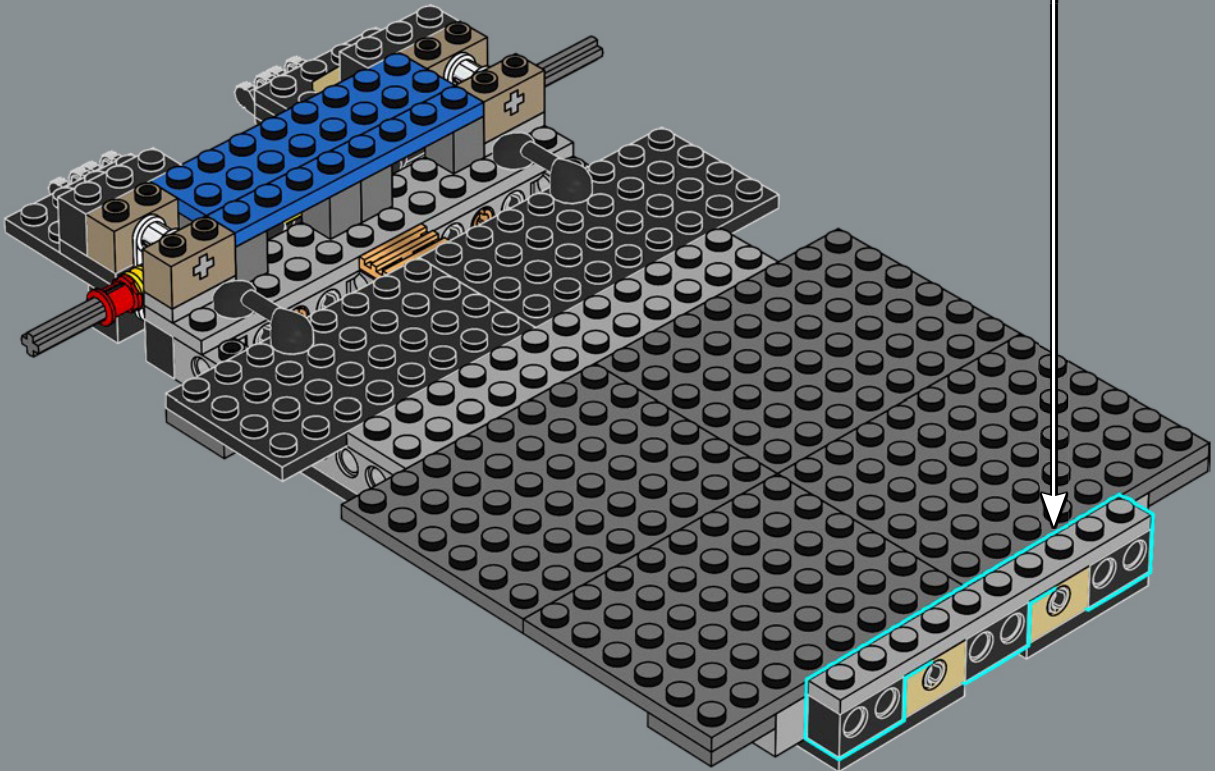
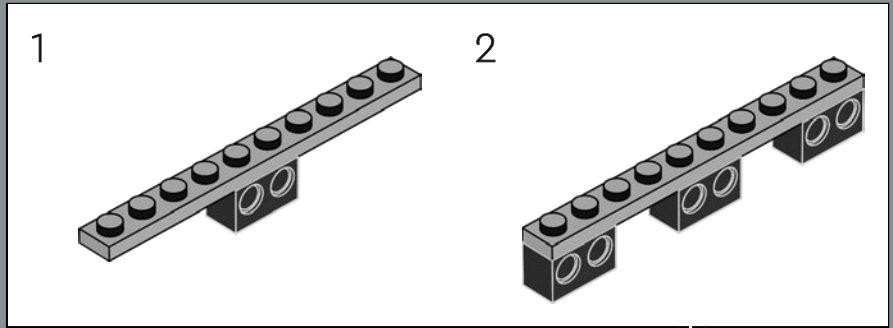



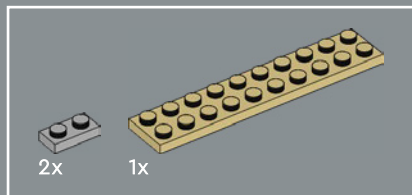

30

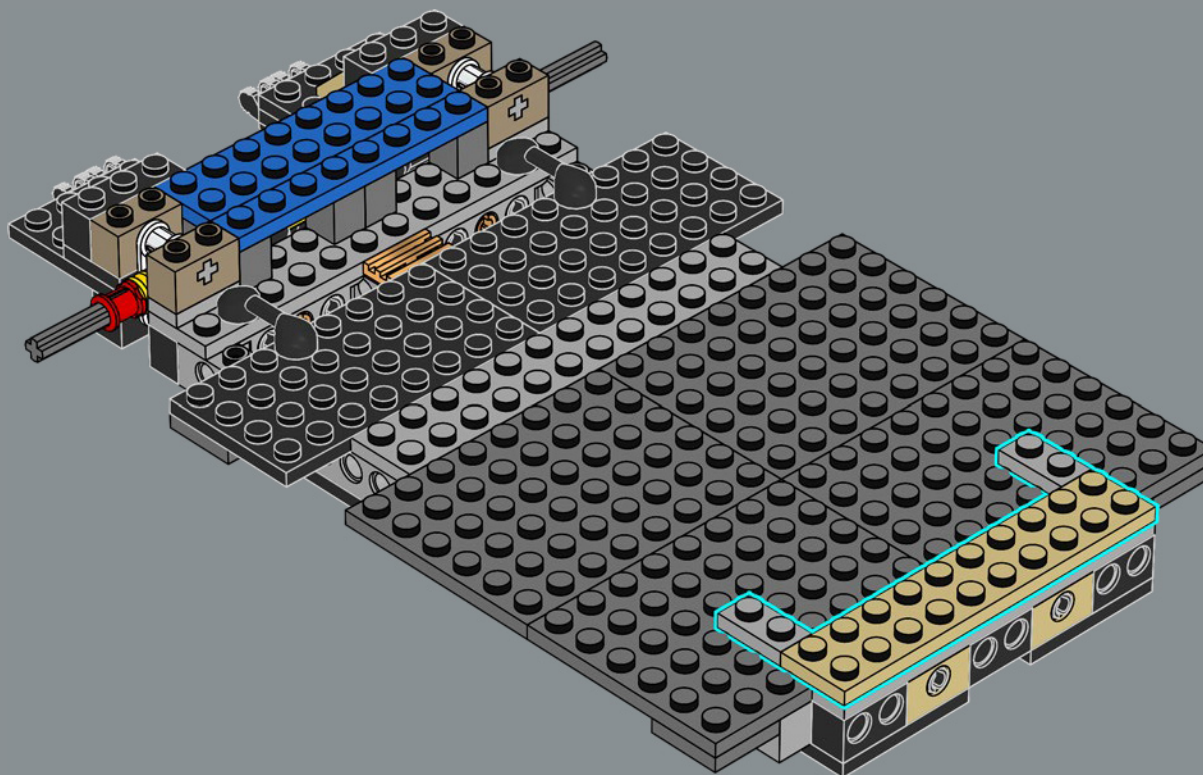

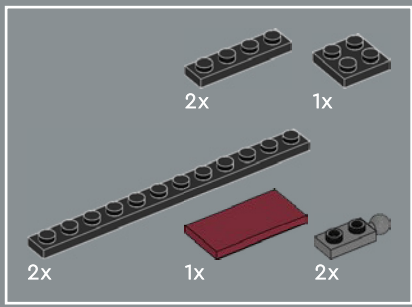

31

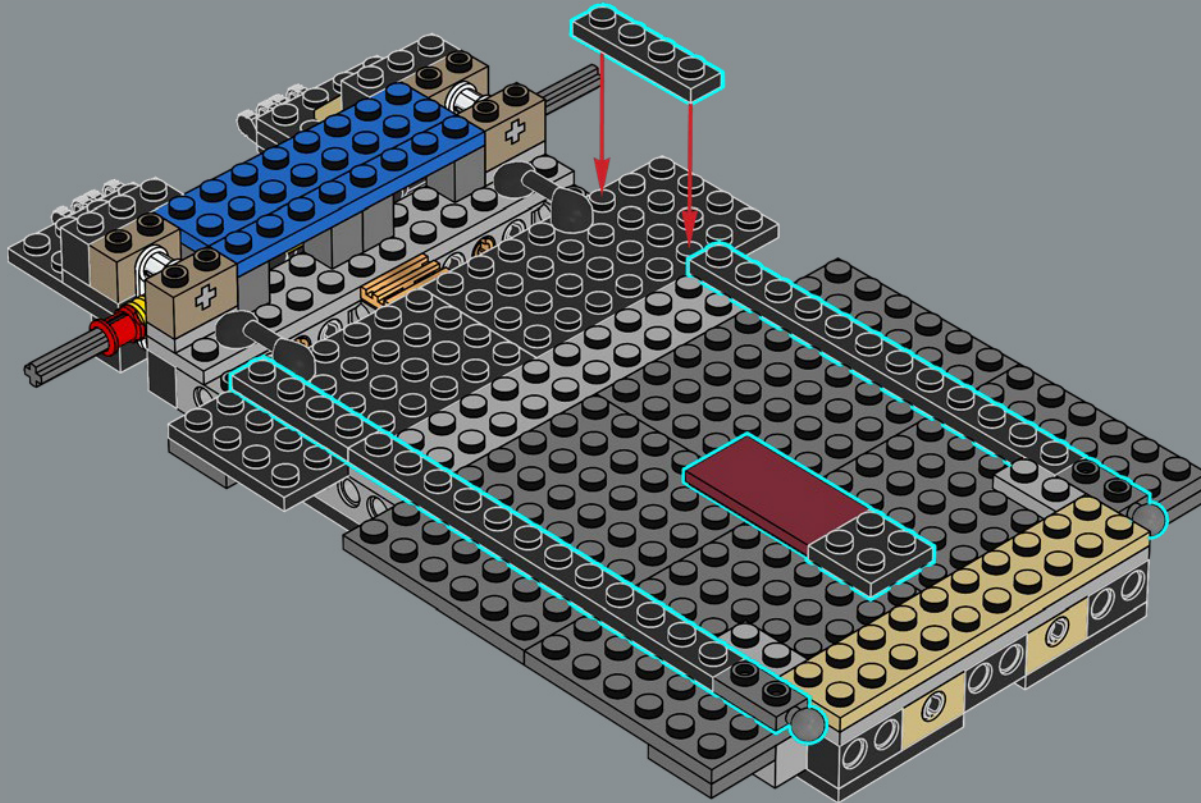

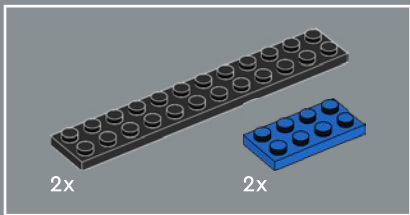

32

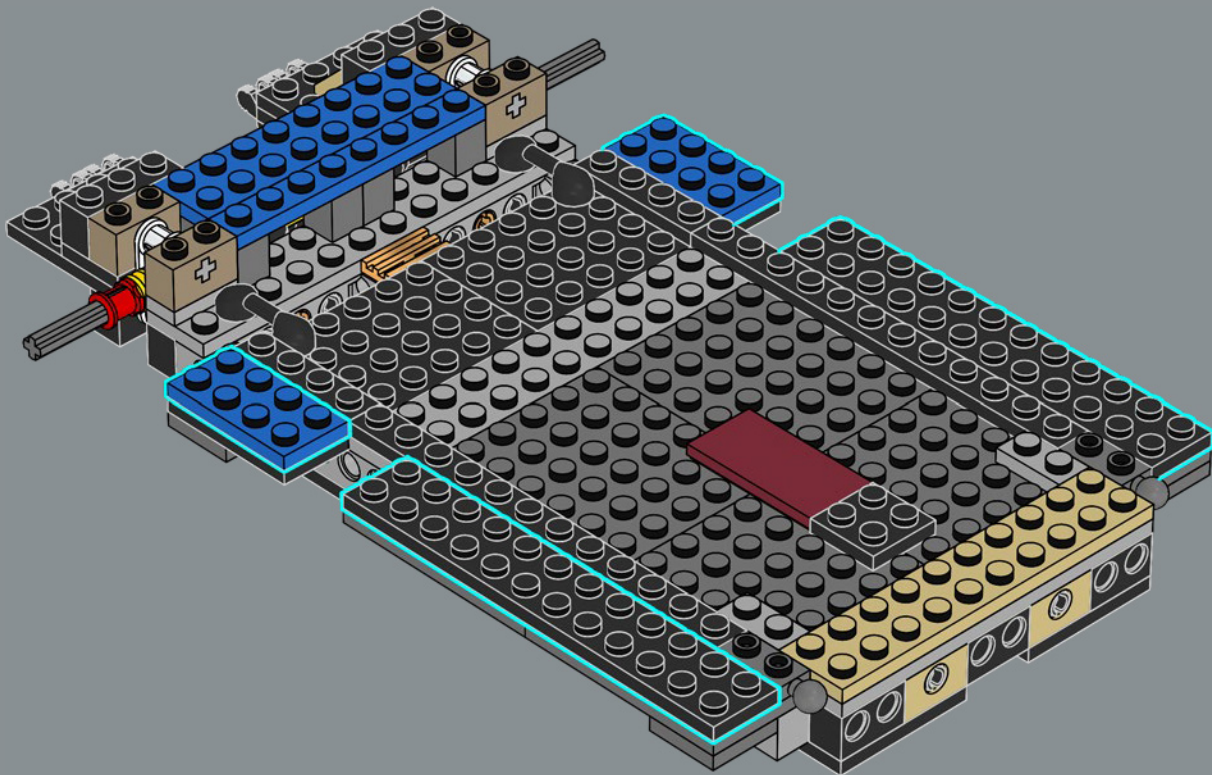



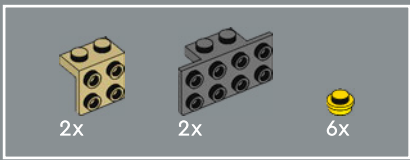

33

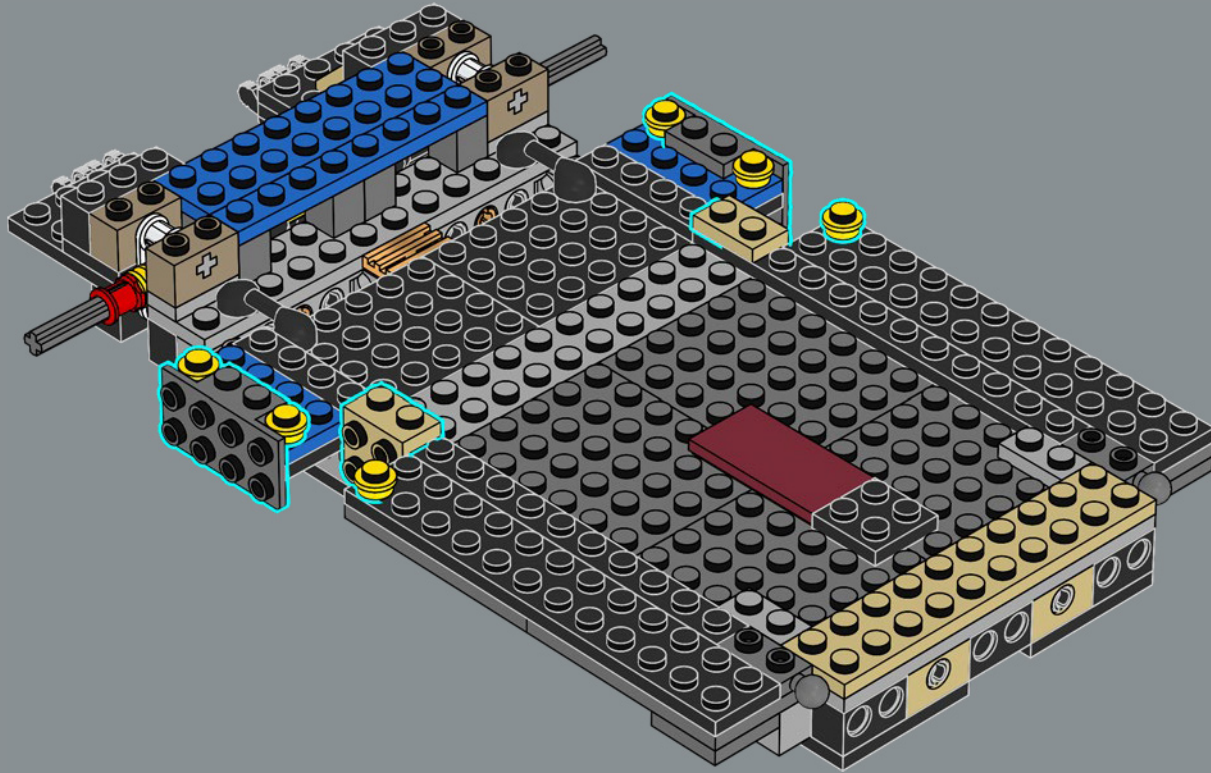



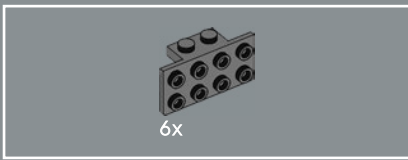

34



The original Lamborghini Countach was designed by Carrozzeria Bertone.

La Lamborghini Countach originale a été conçue par Carrozzeria Bertone.

El Lamborghini Countach original fue diseñado por Carrozzeria Bertone.

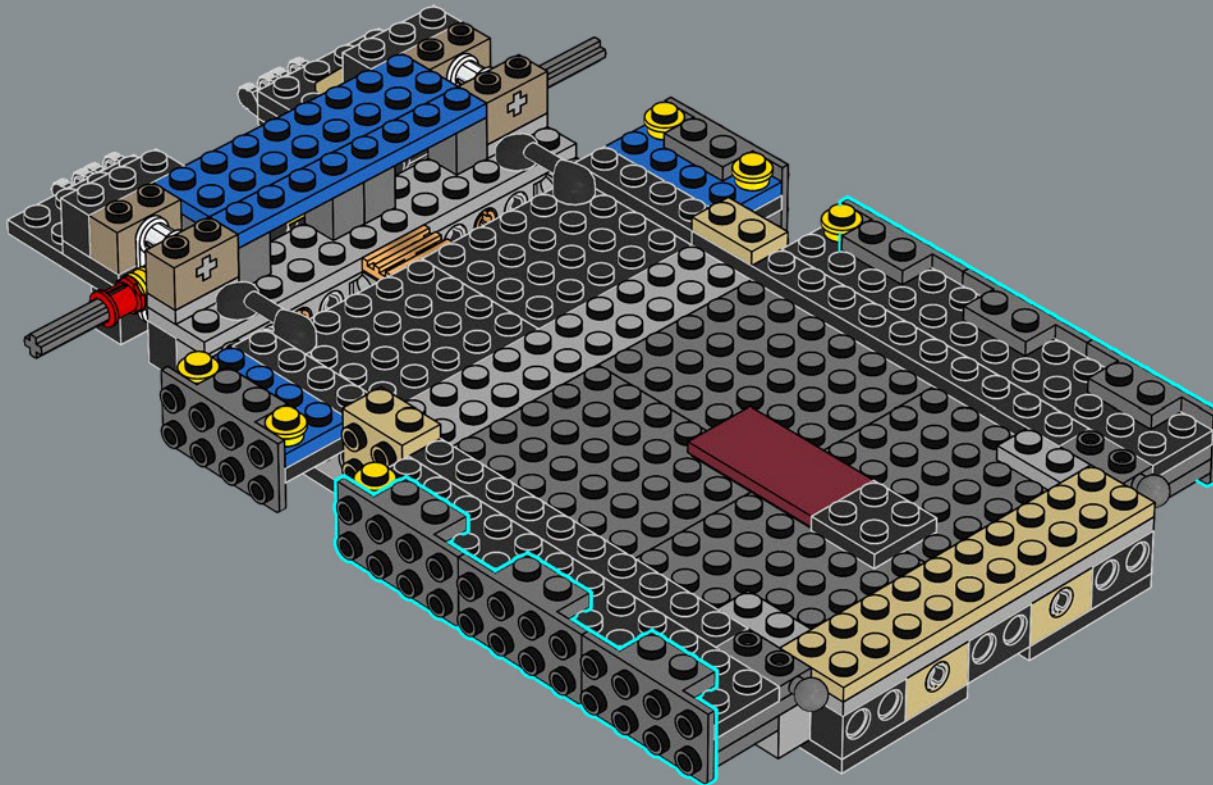

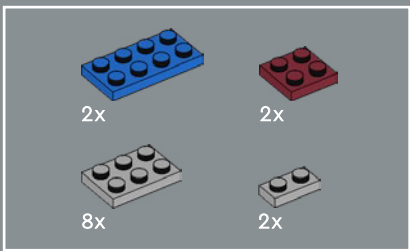

35

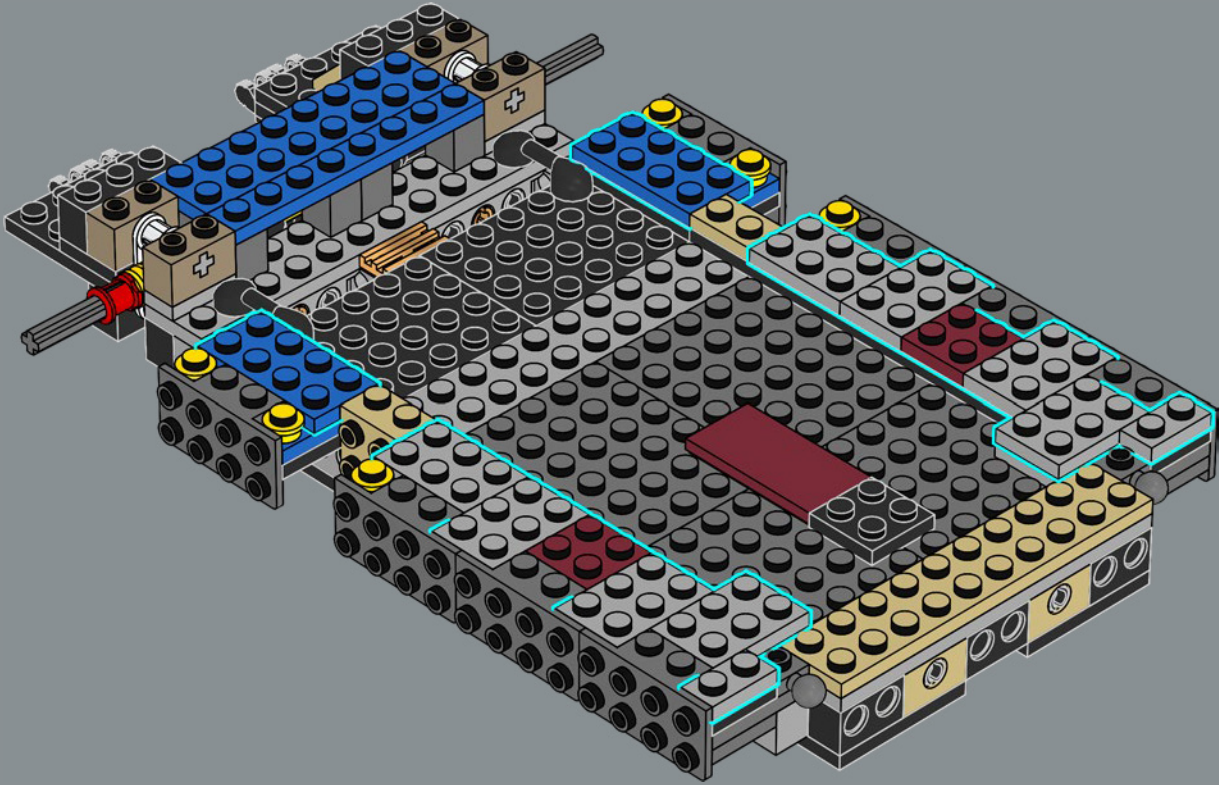

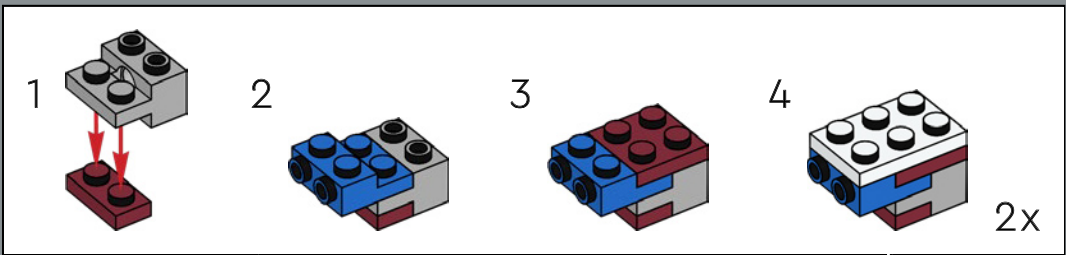
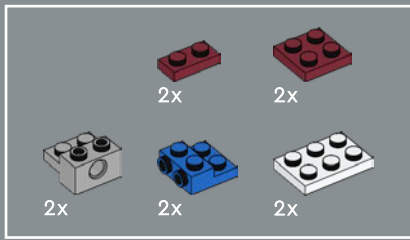

36

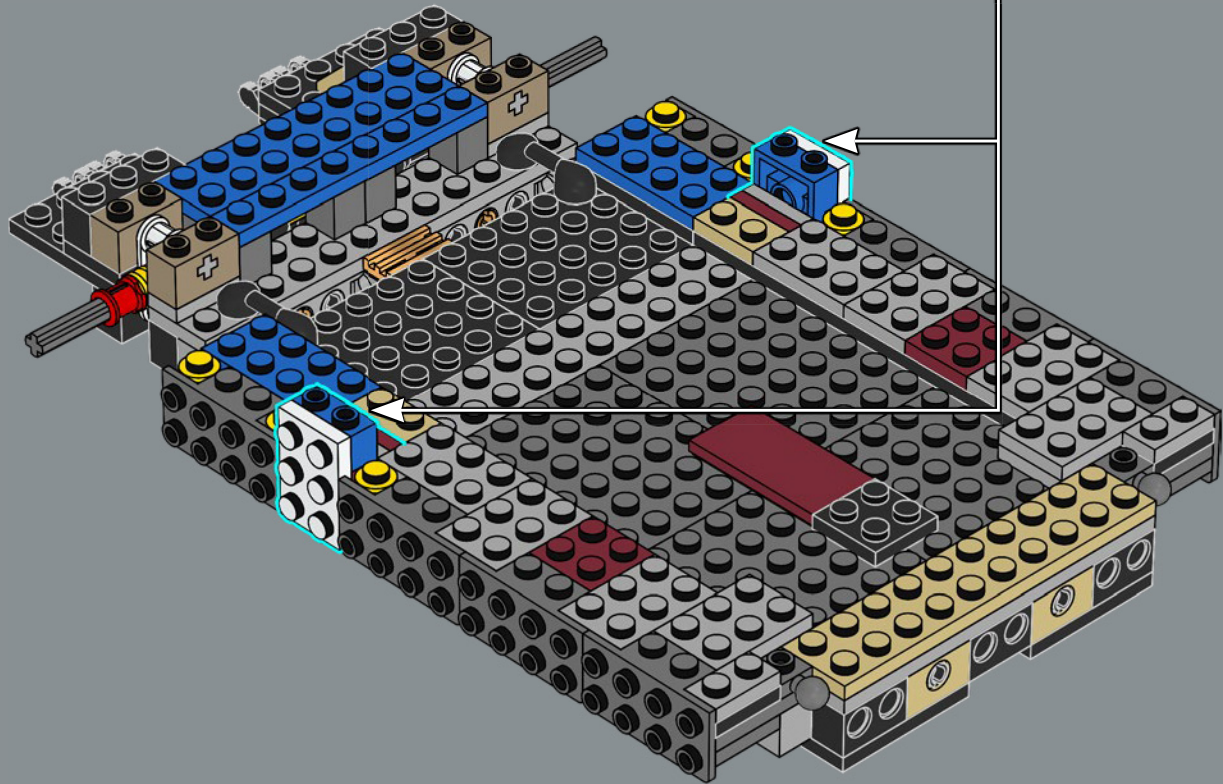



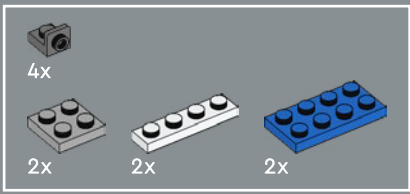

37

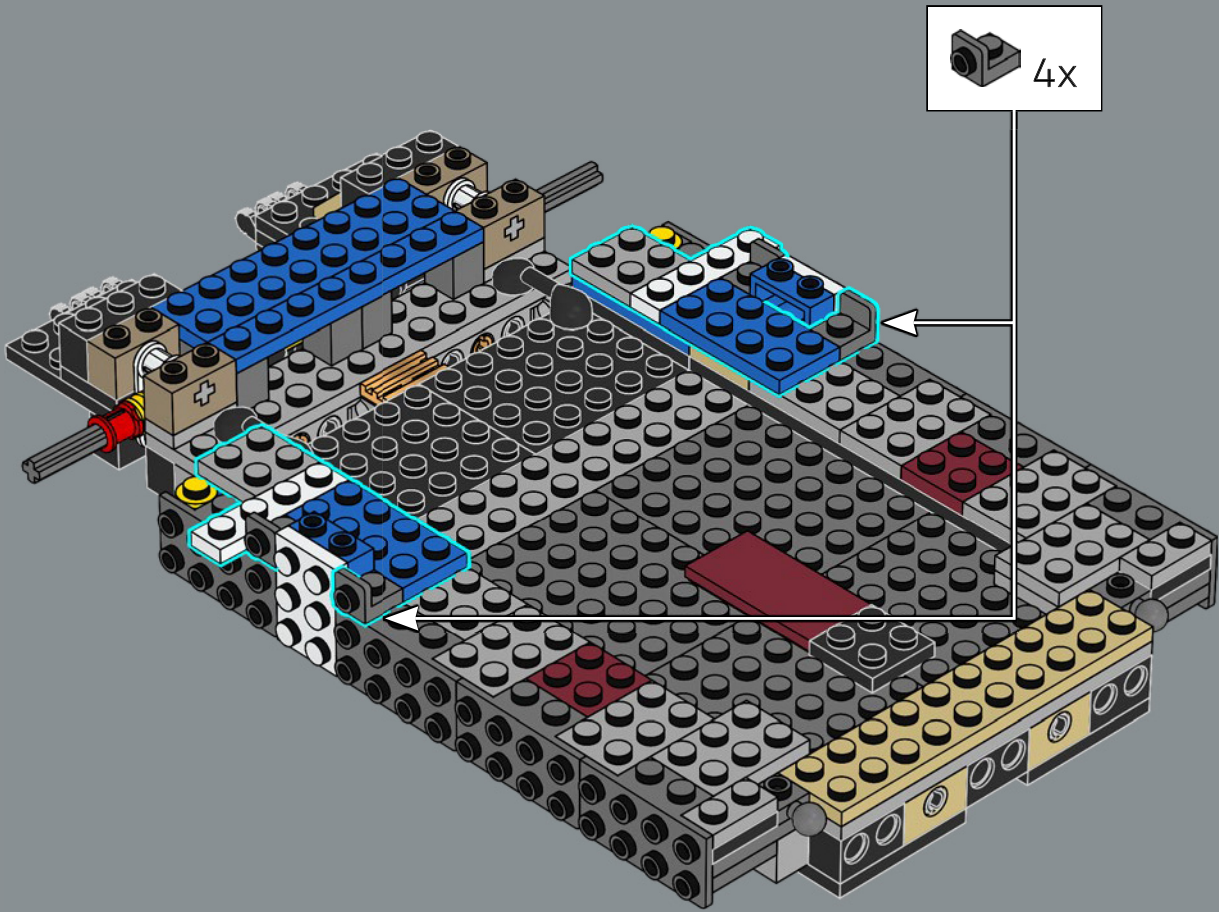





38

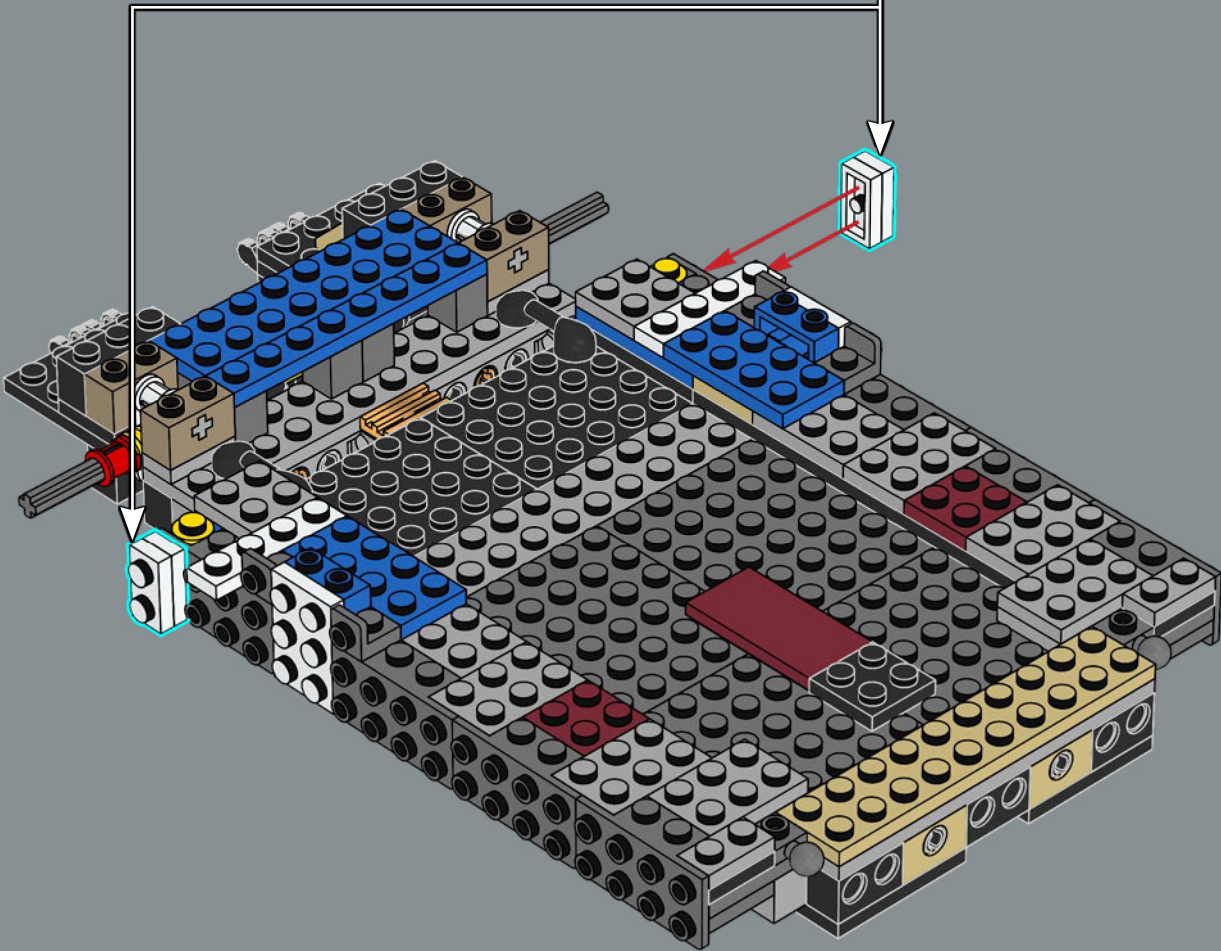
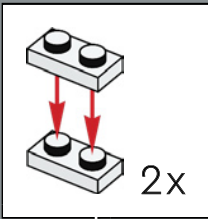

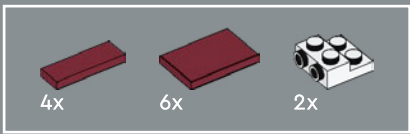

39

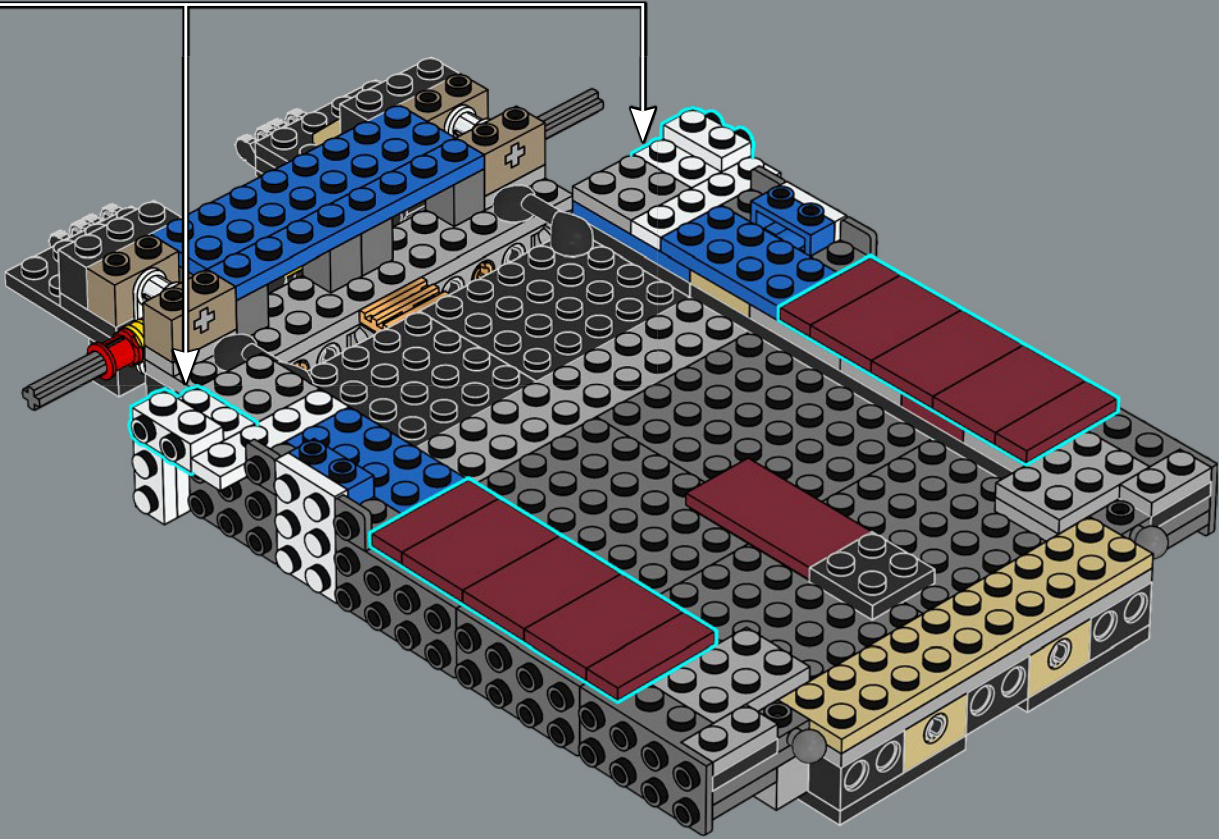
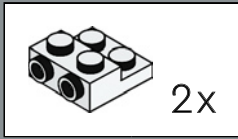

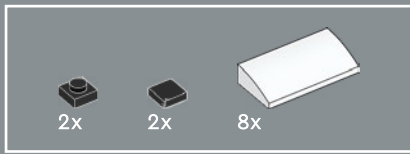

40

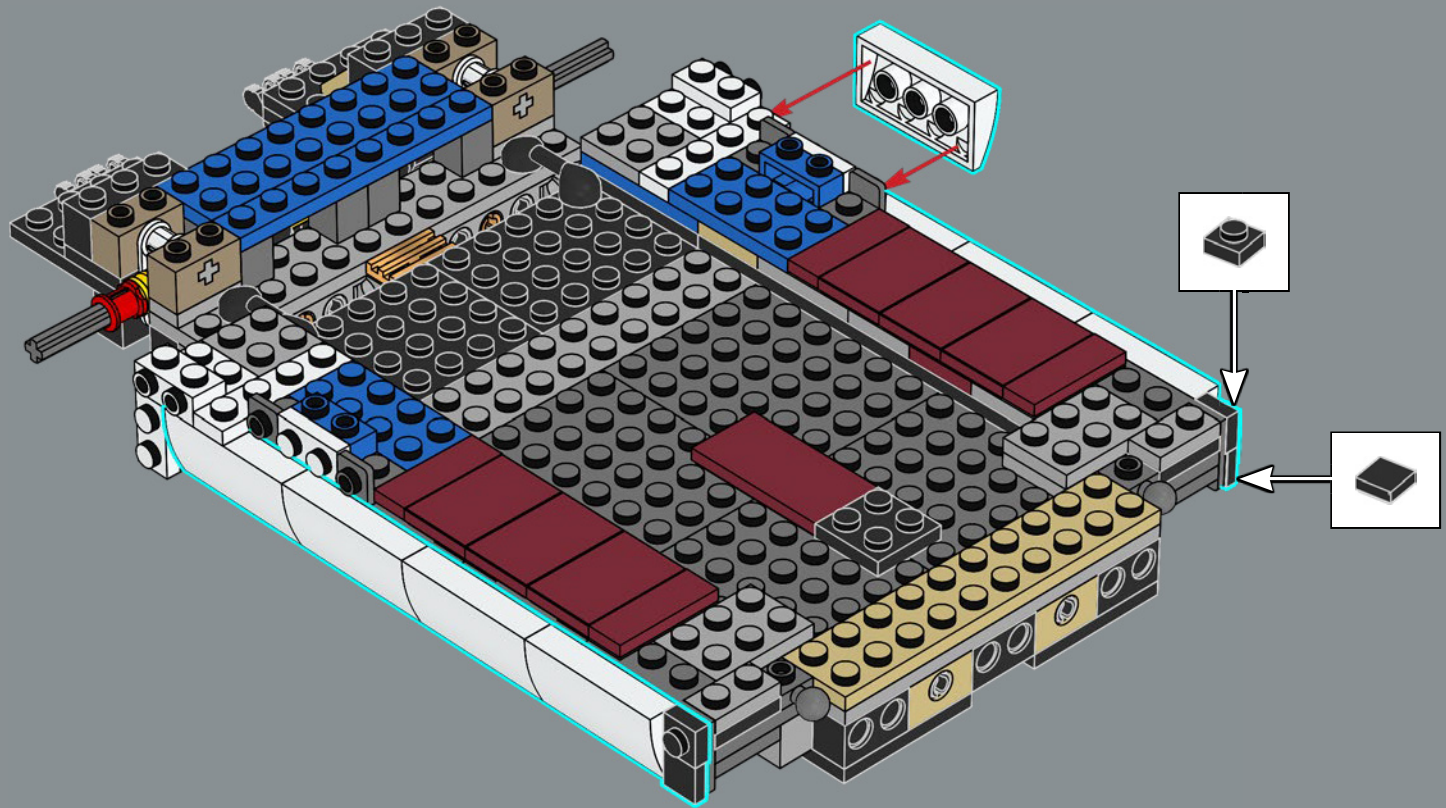



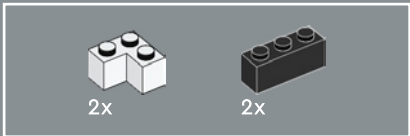

41

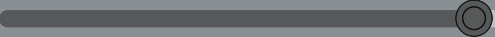
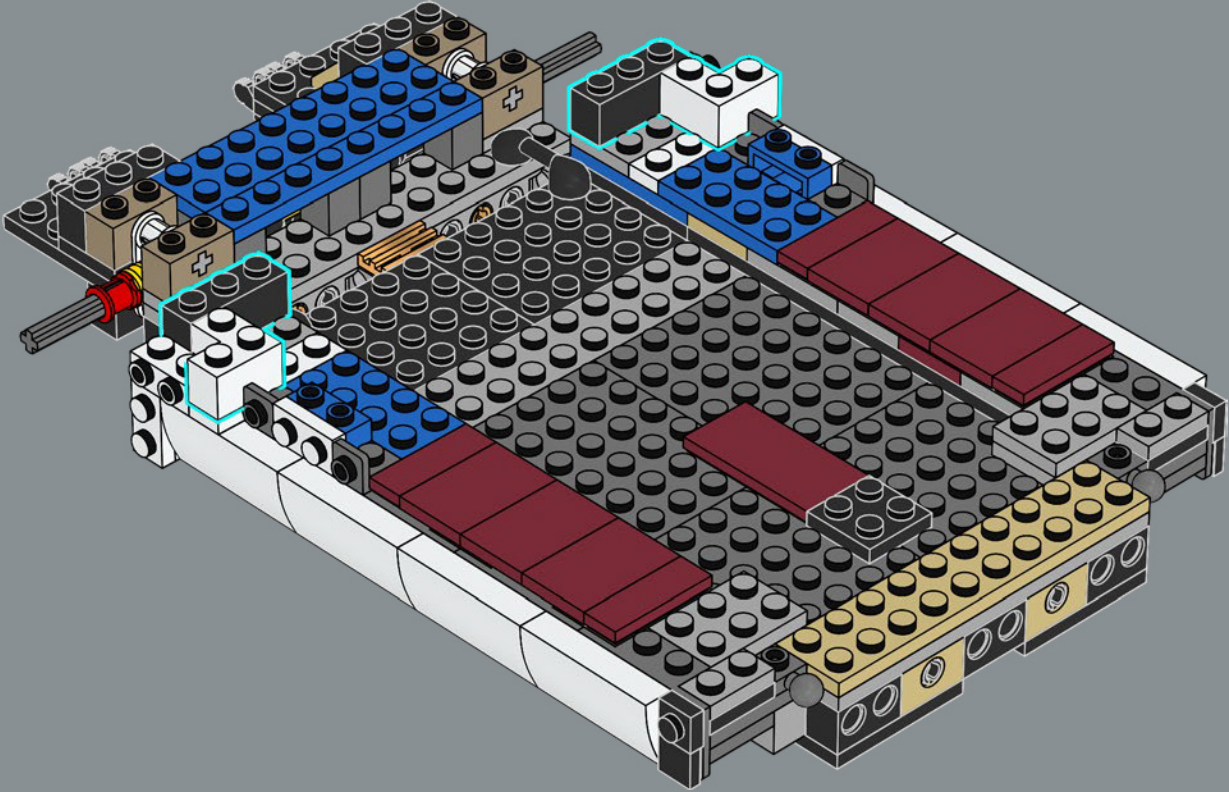



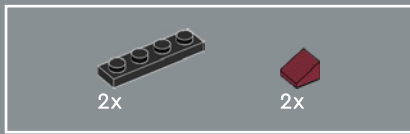

42

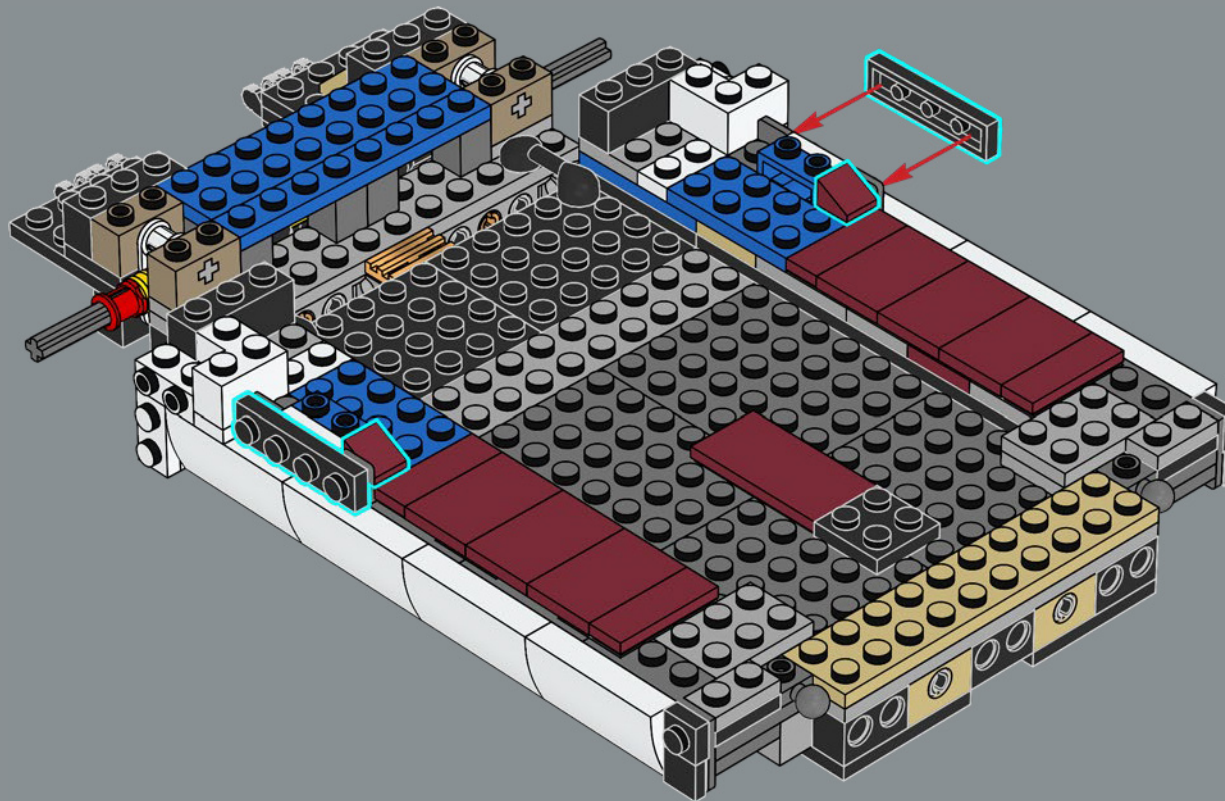



4x

43

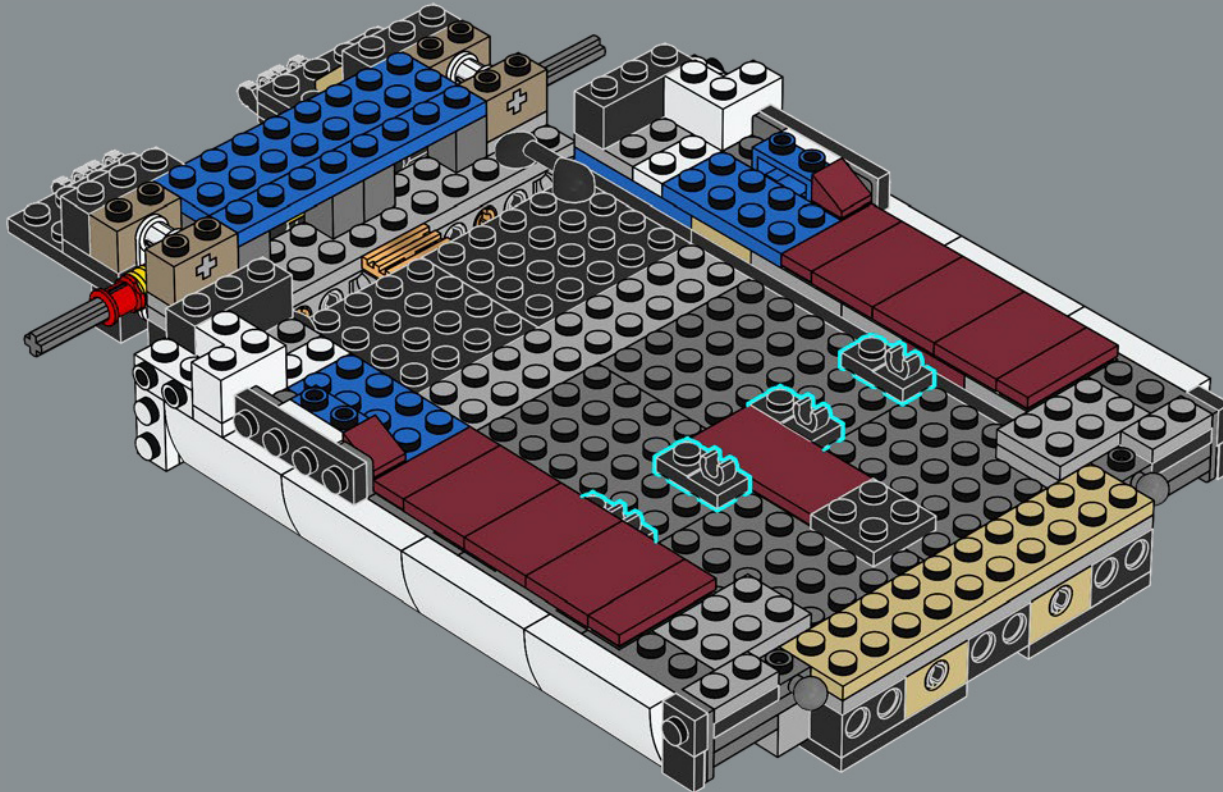

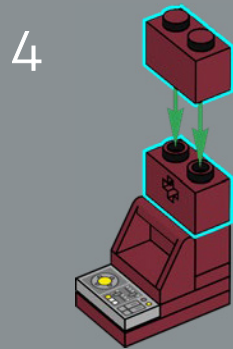
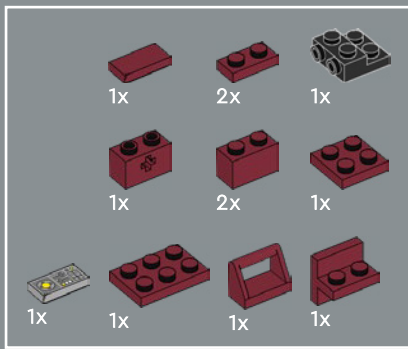

7

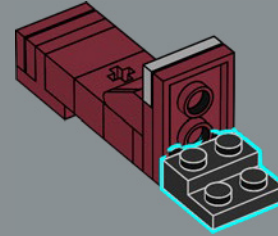

44

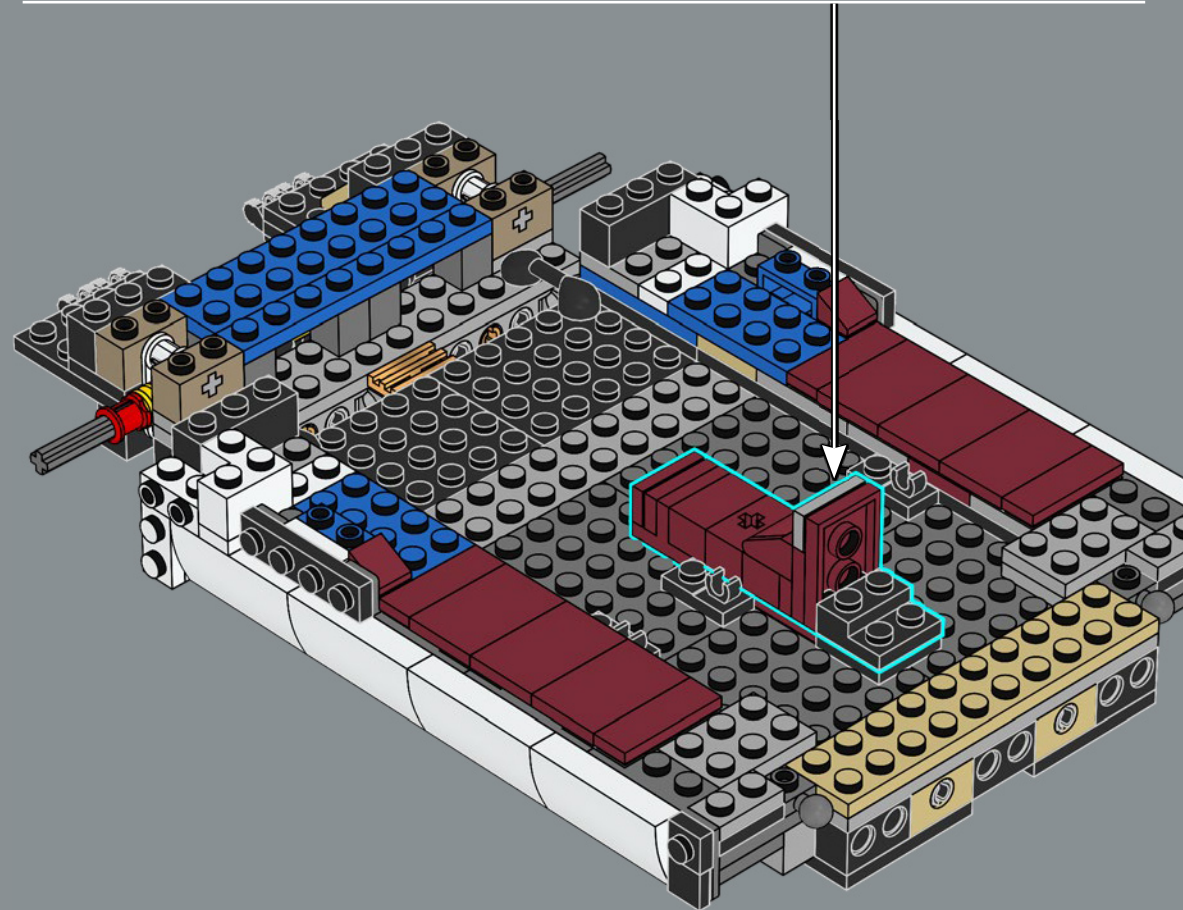
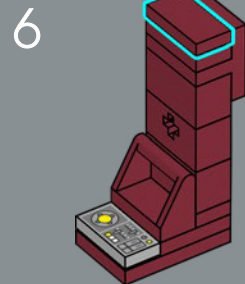
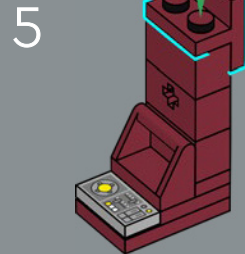
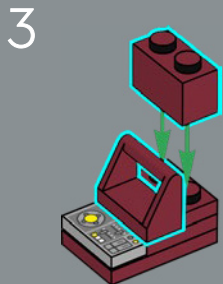
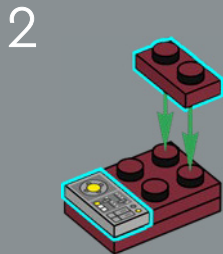
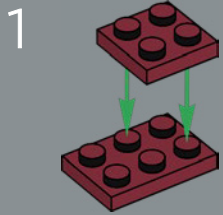





45

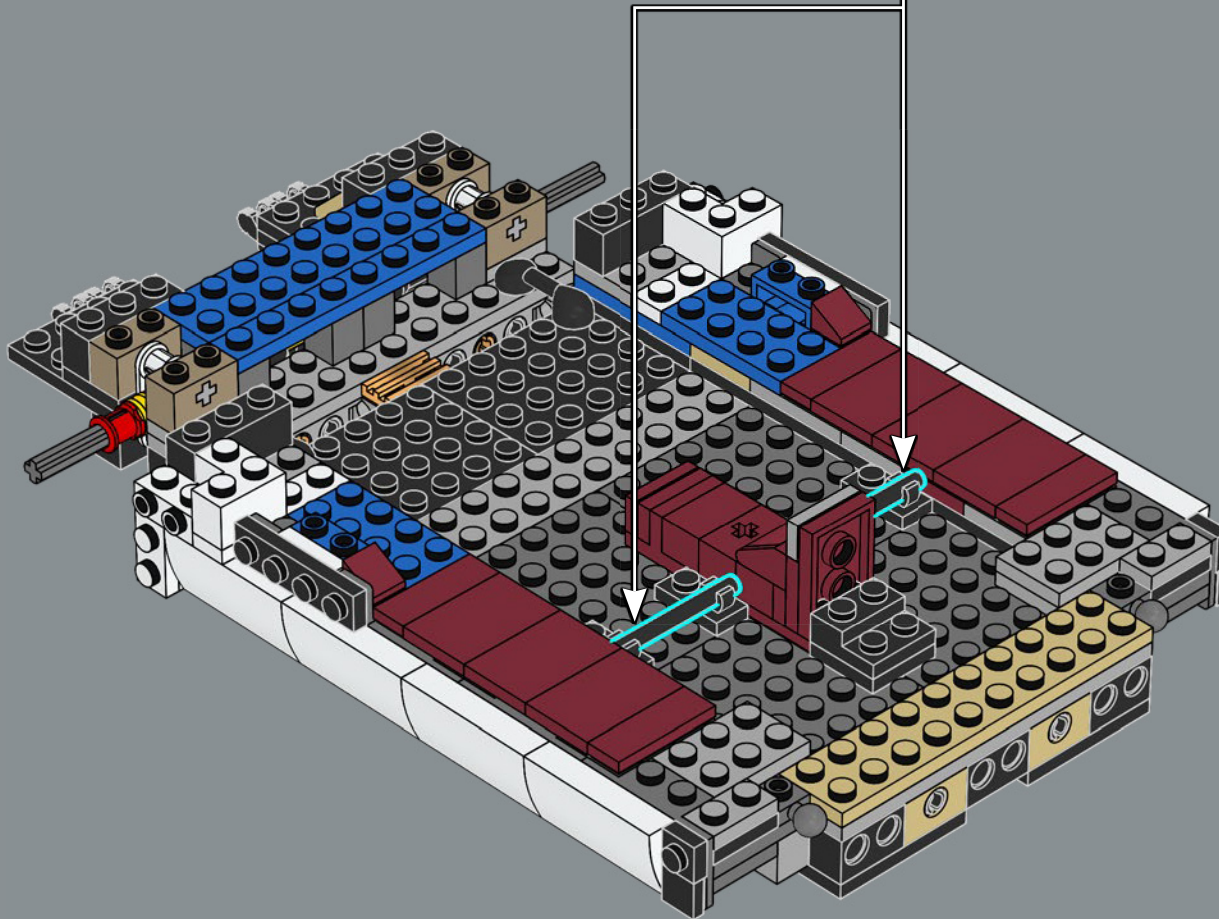
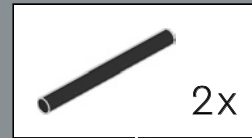



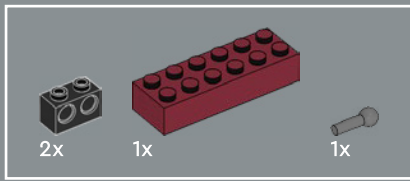

46

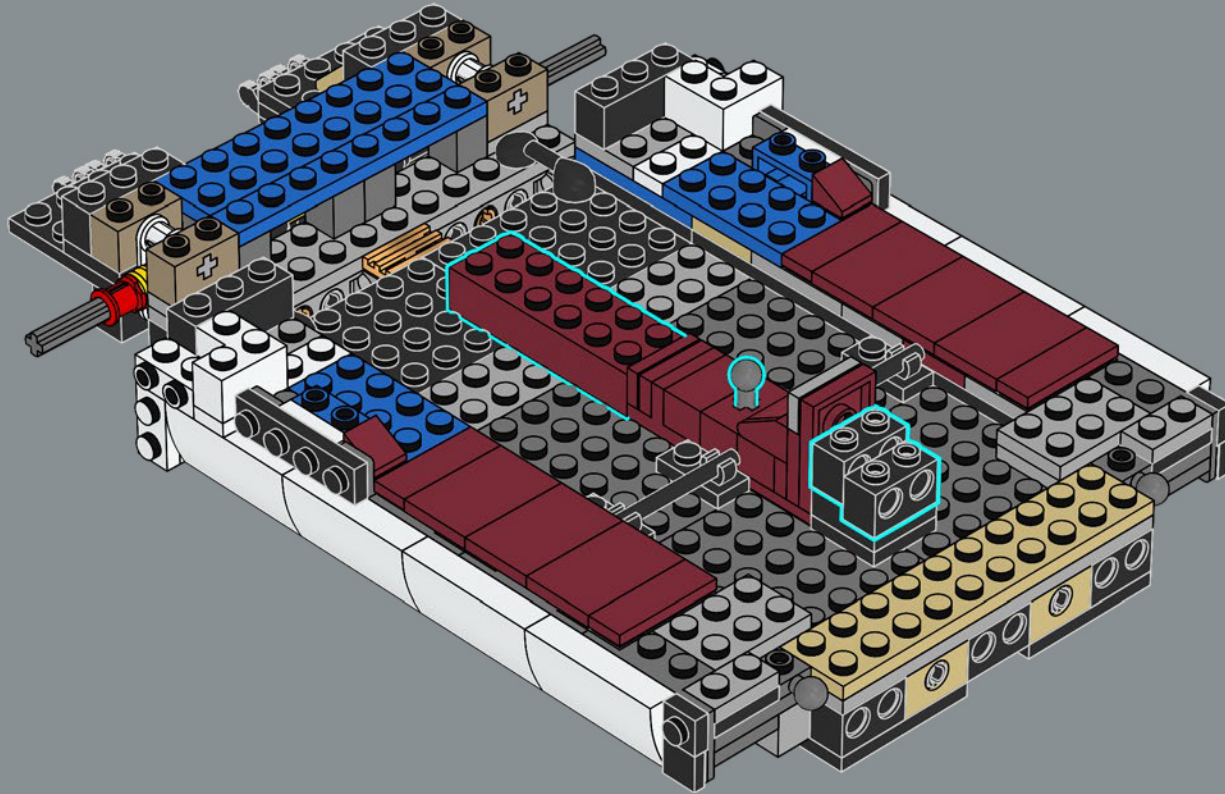

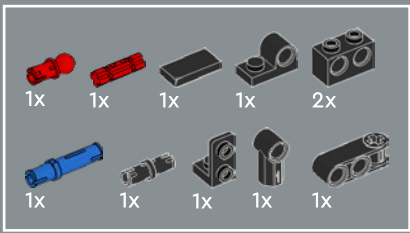

# 47

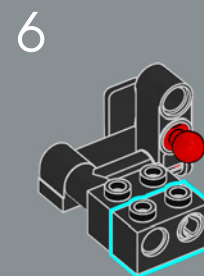
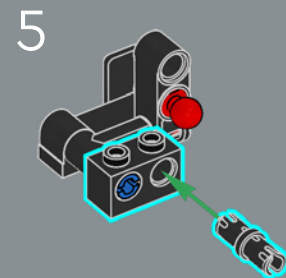
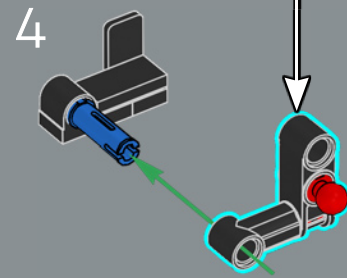
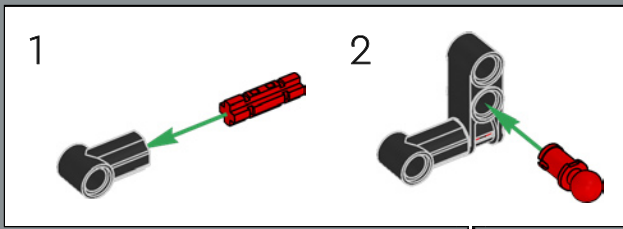
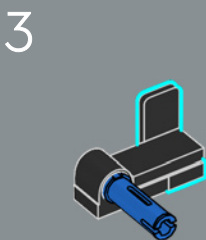
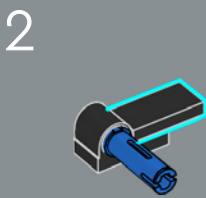
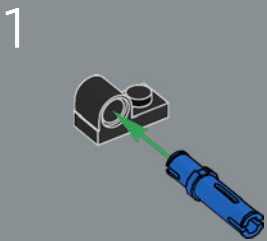

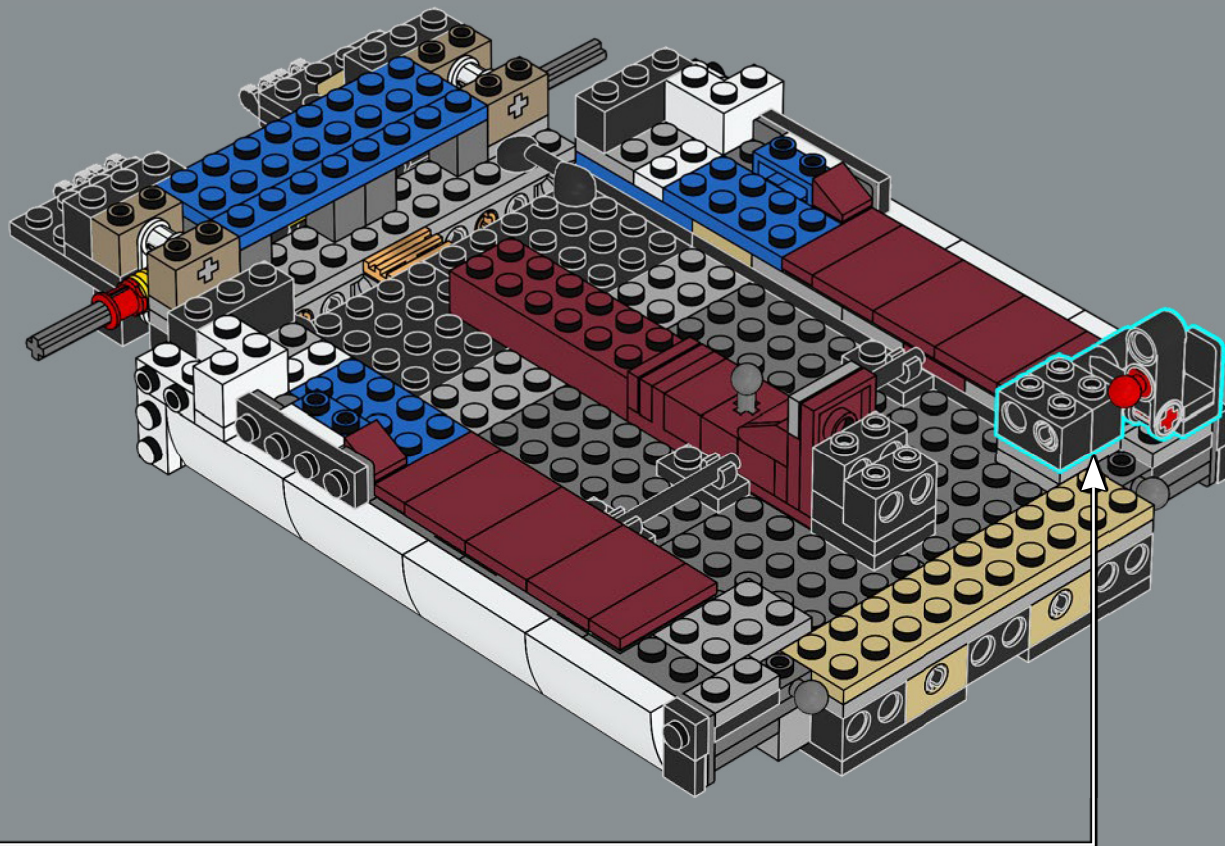

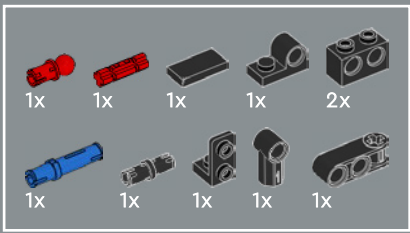

48

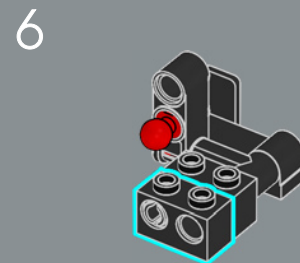
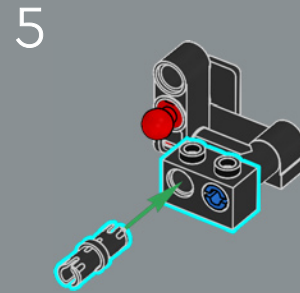
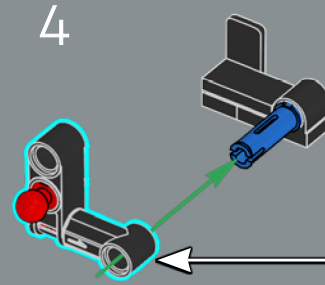
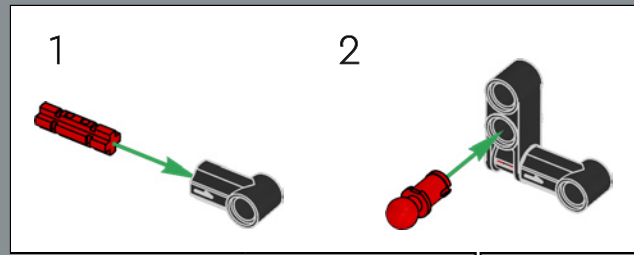
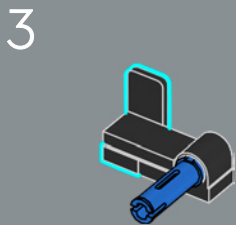
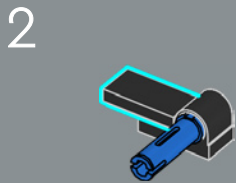
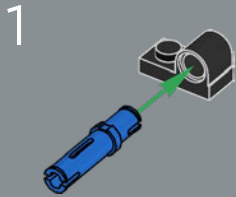



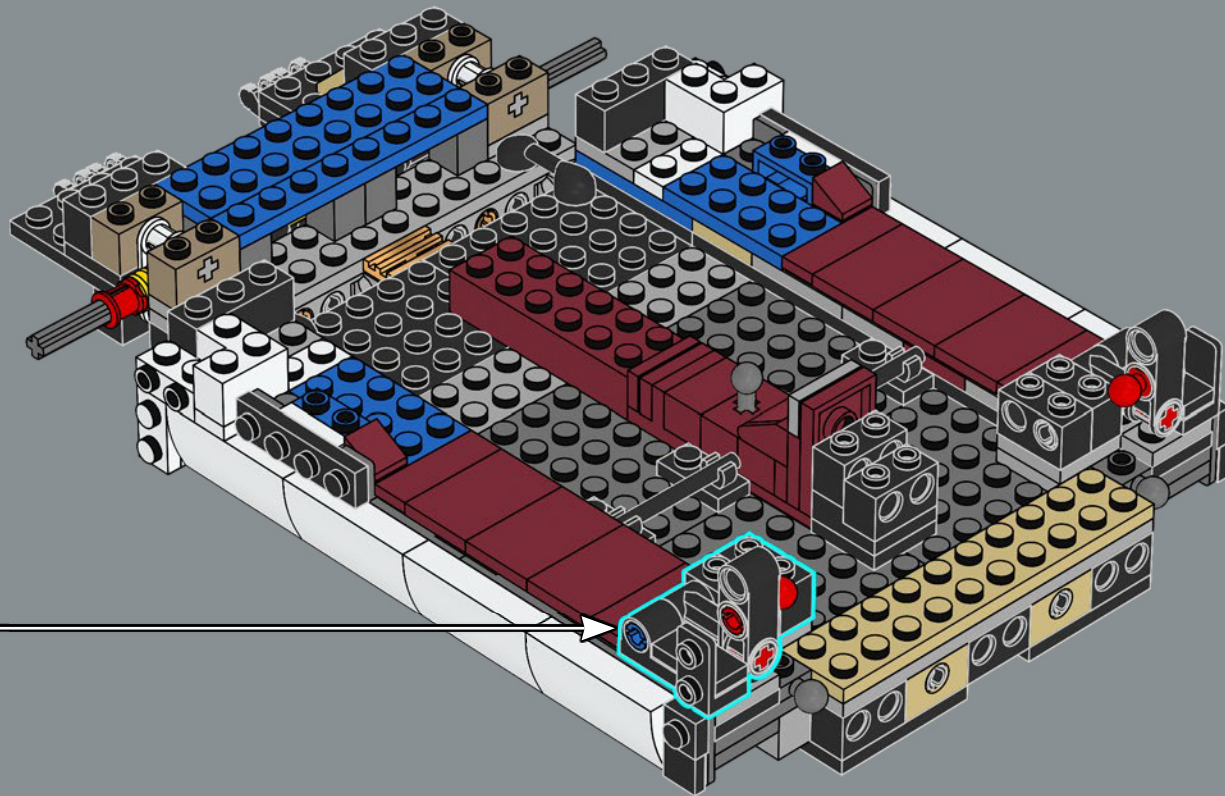

0  
2x

49

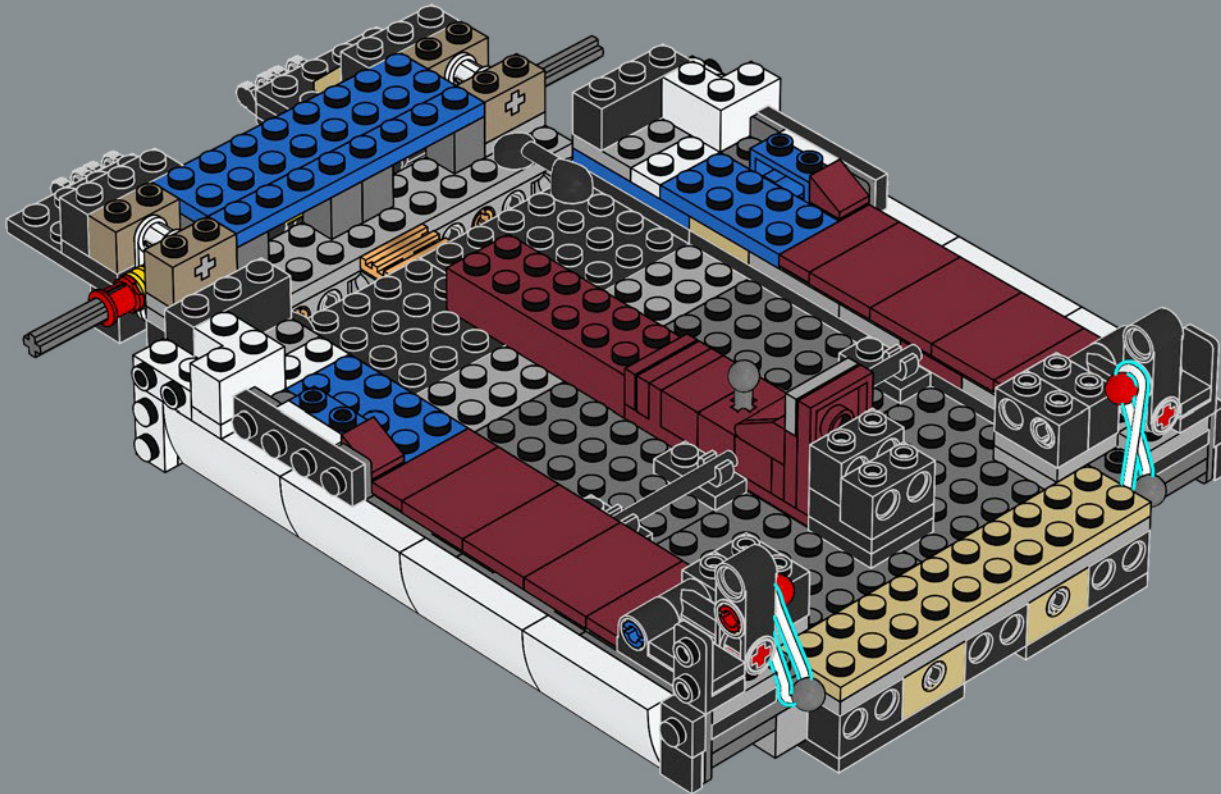

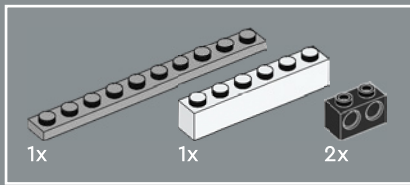

50

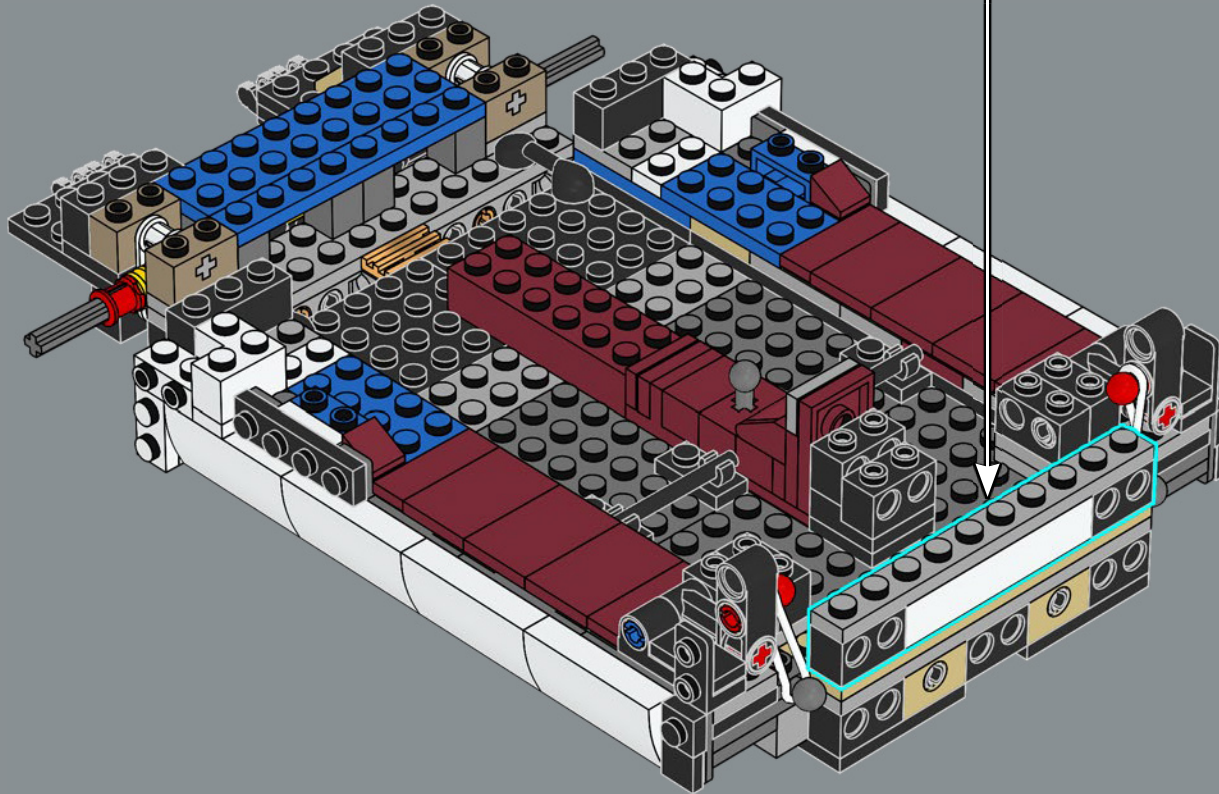
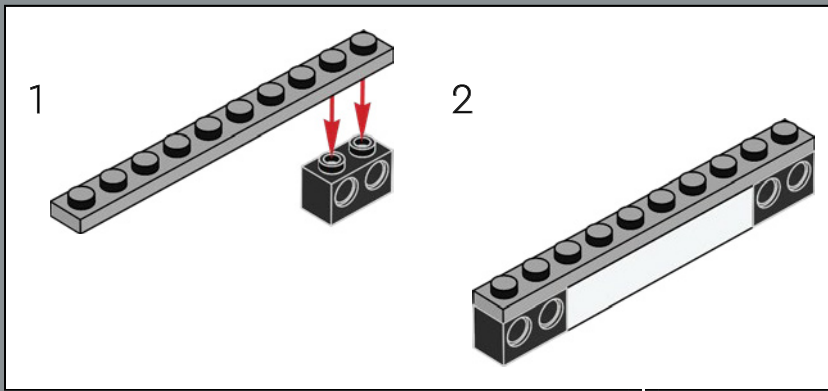



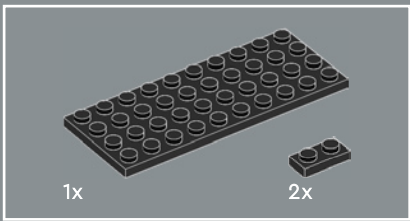

51

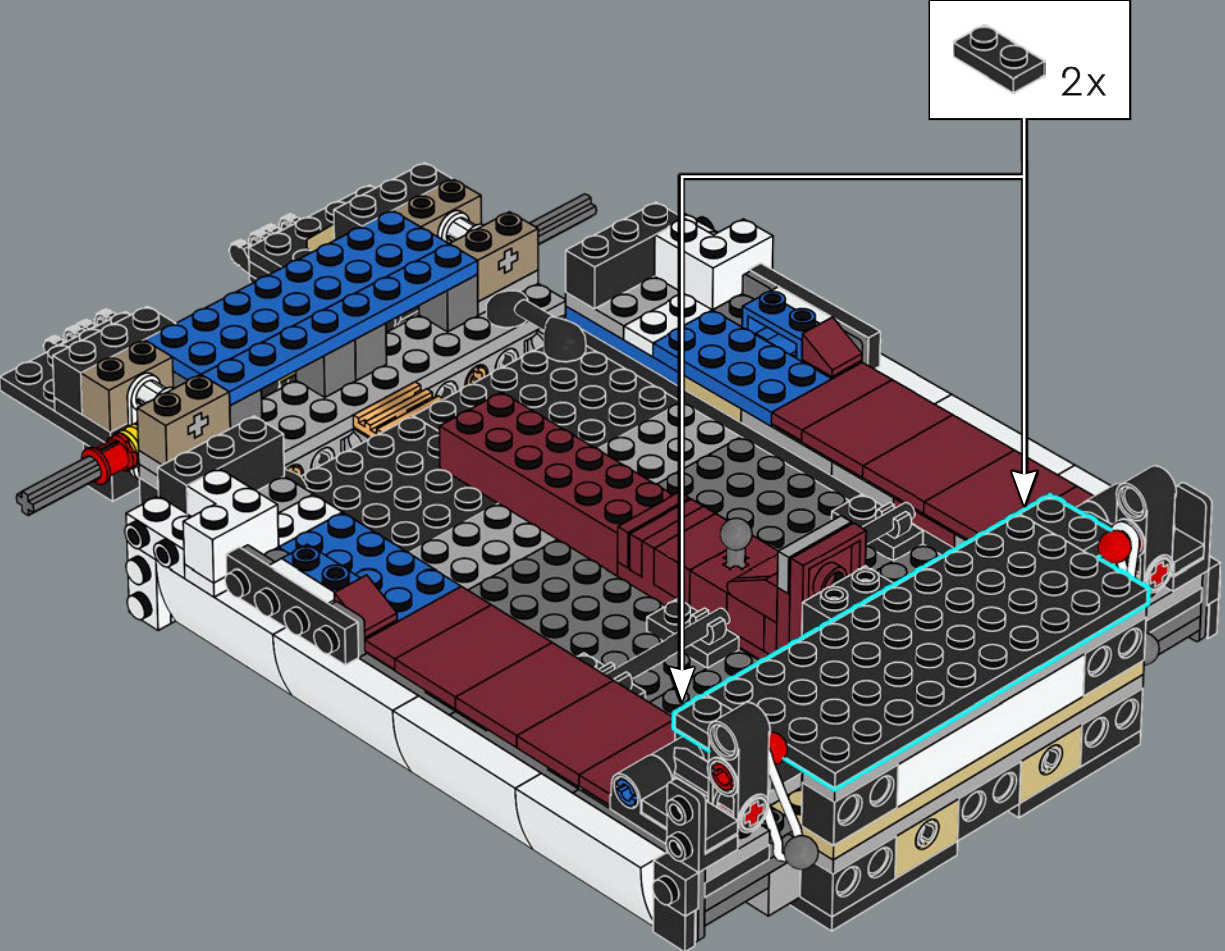



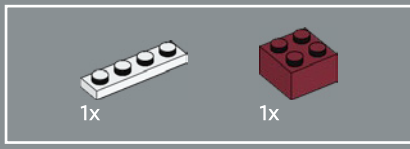

52

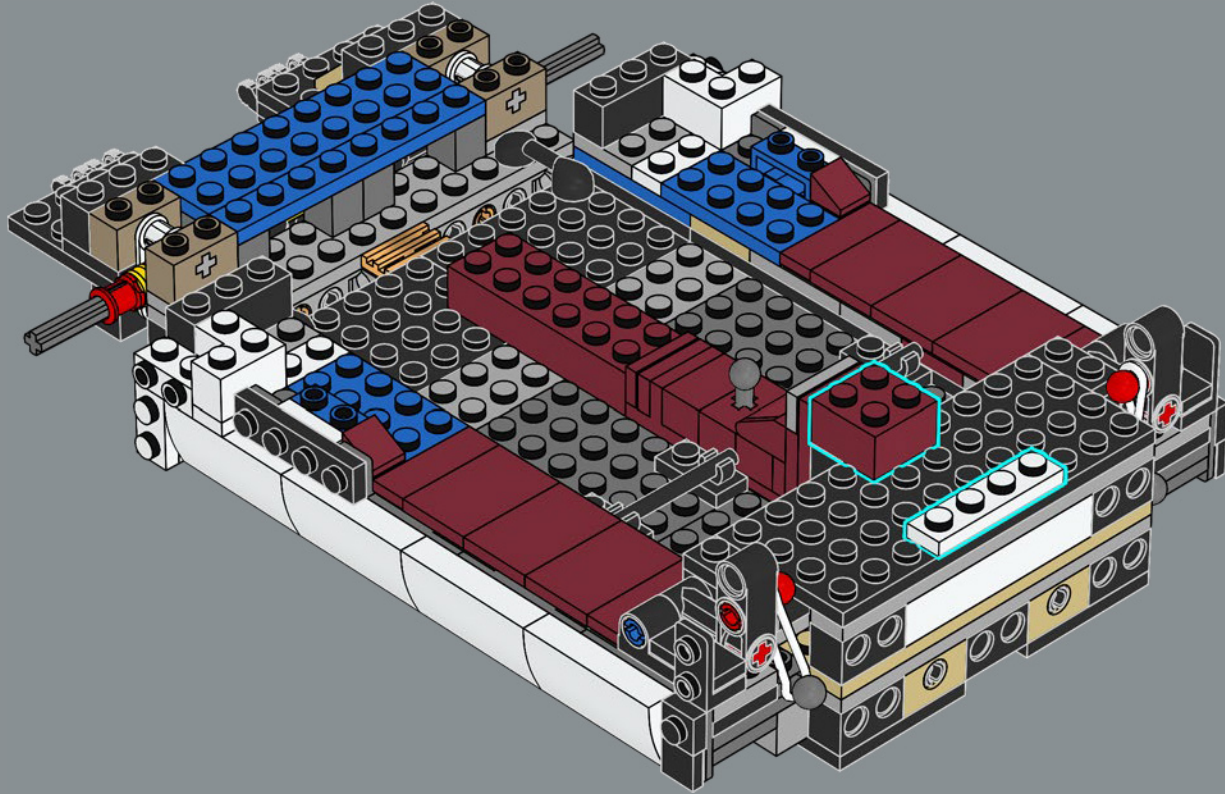

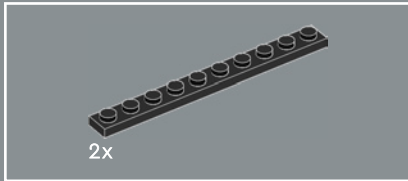
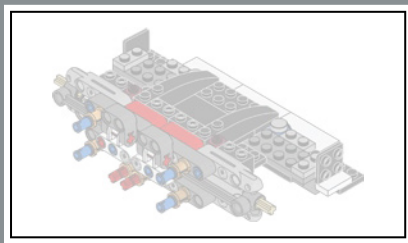

53

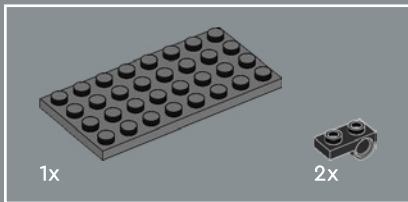
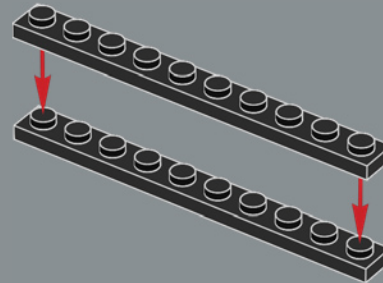

54

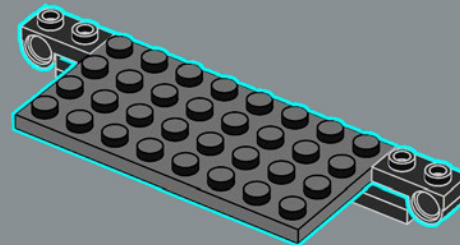

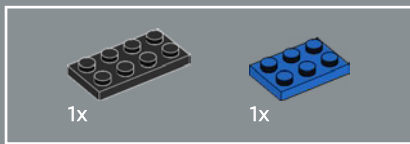

55

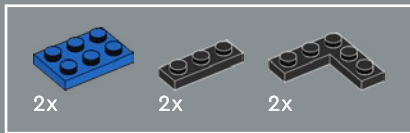
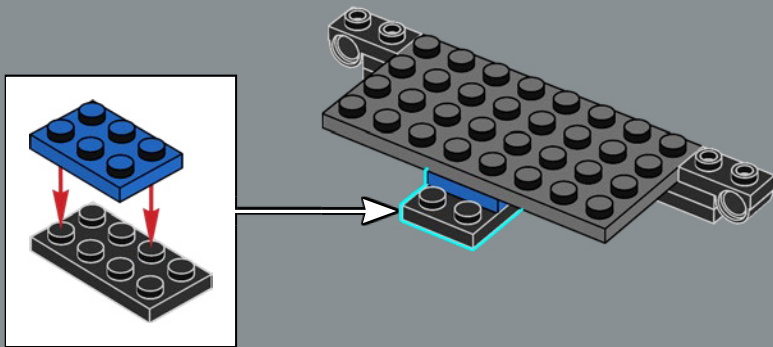

56

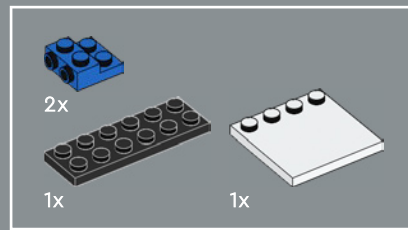
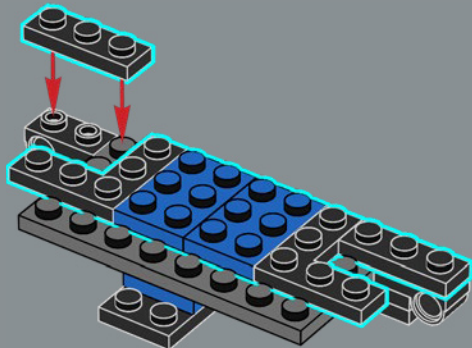

57

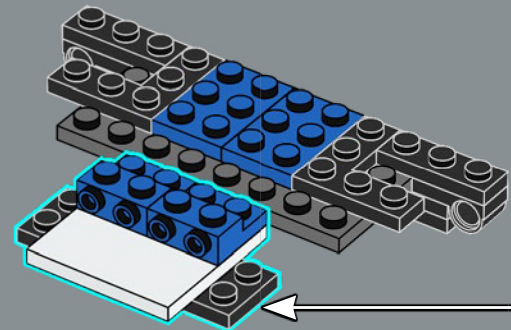
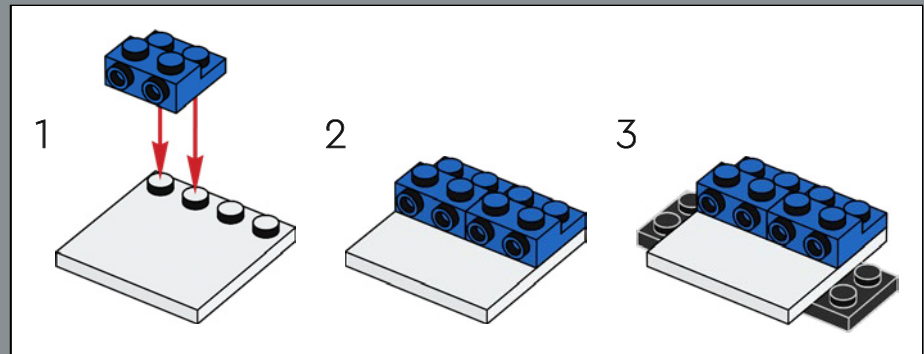

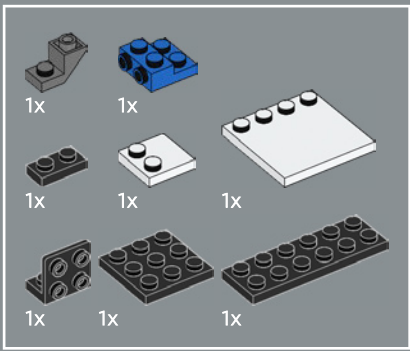

58

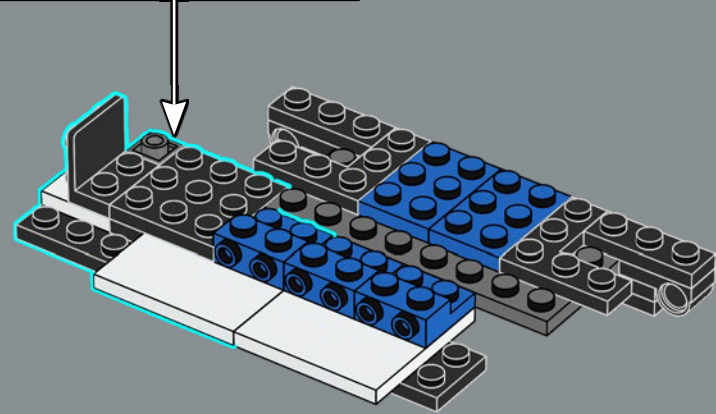
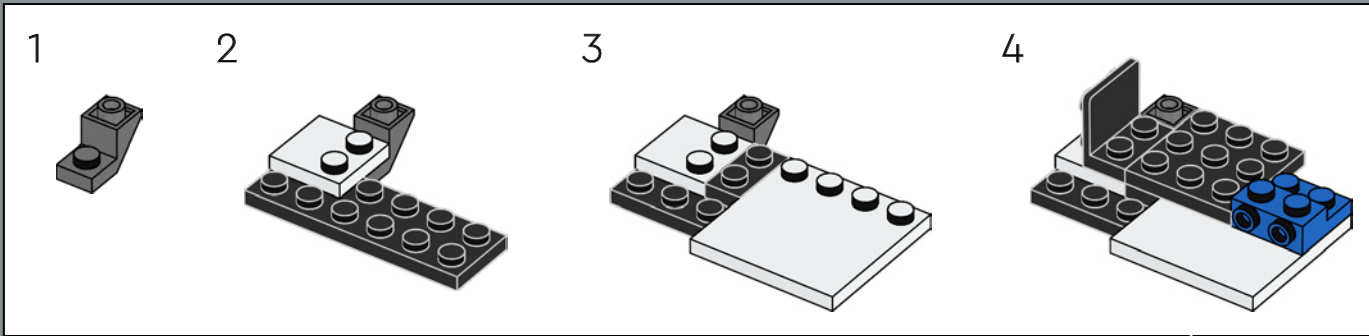



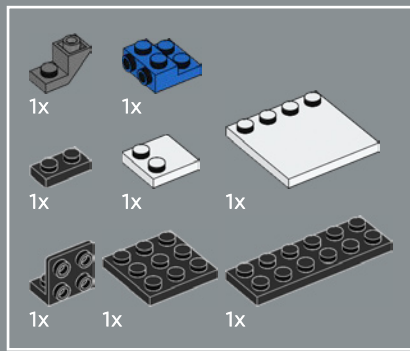

59

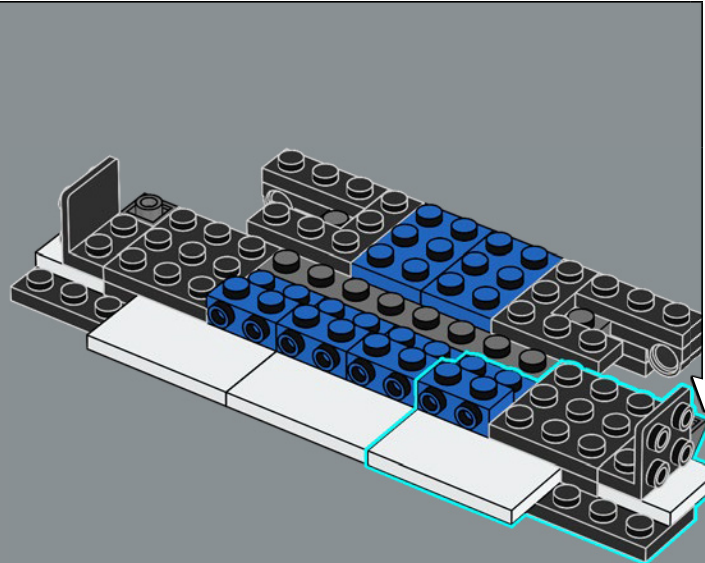
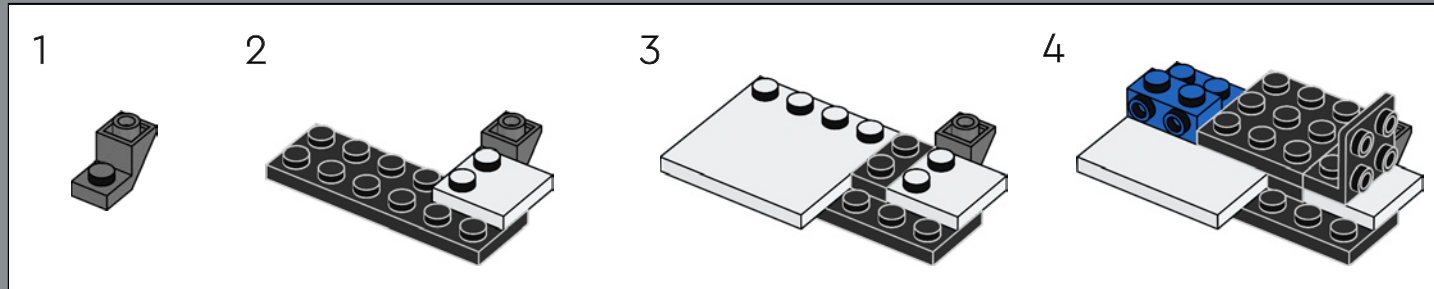

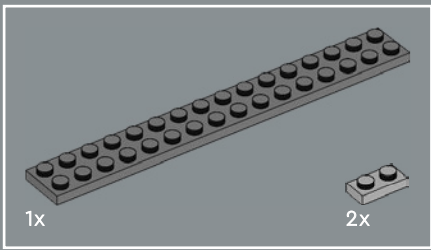

60

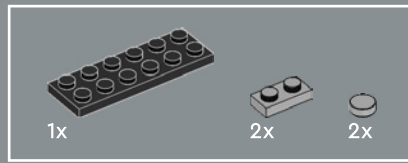
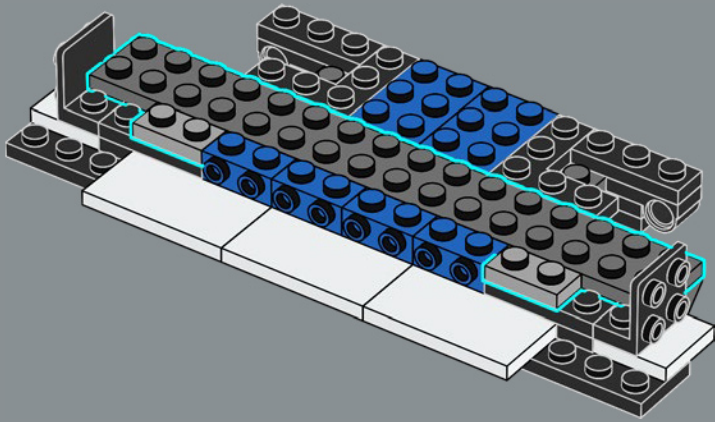

61

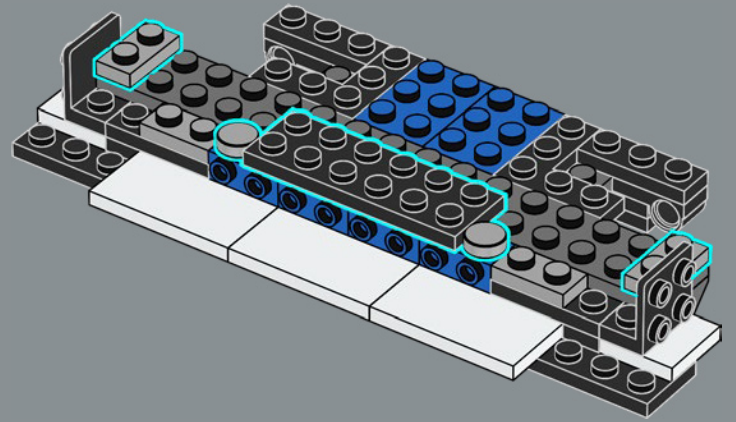

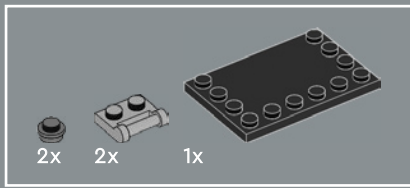

62

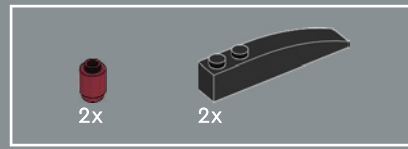
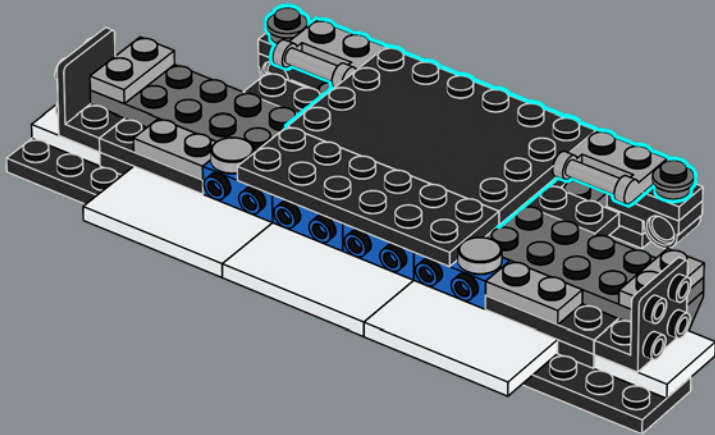

63

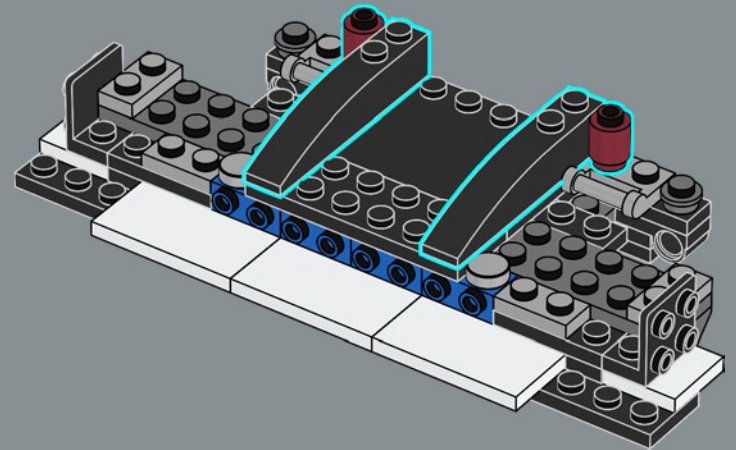

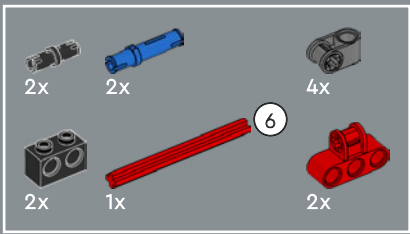

64

1

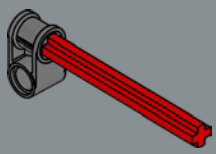

2

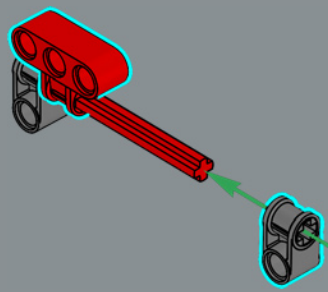

3

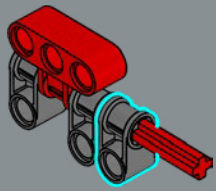

4

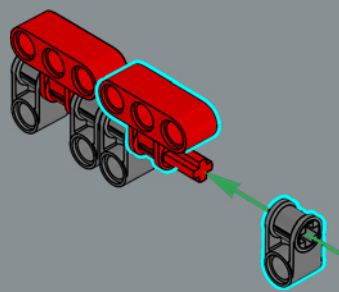

5

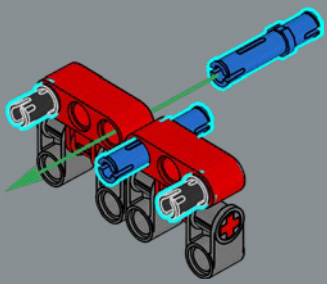

6

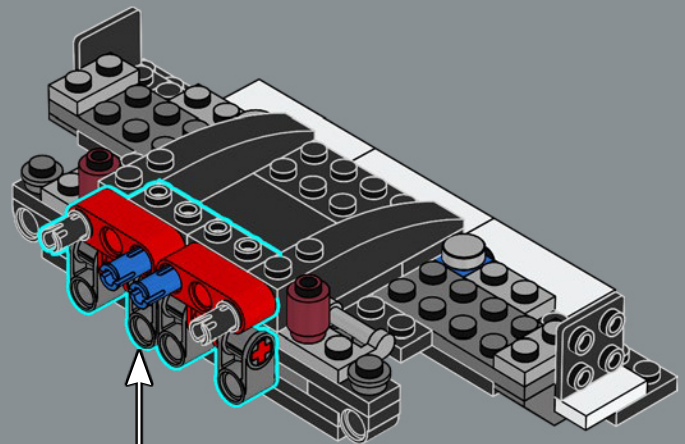
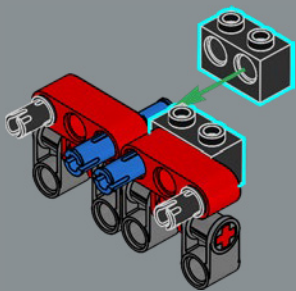



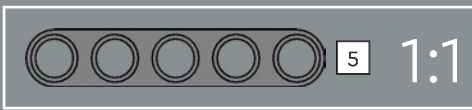
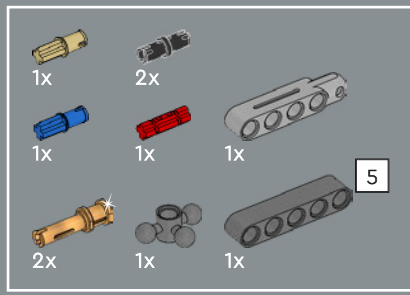

65

1

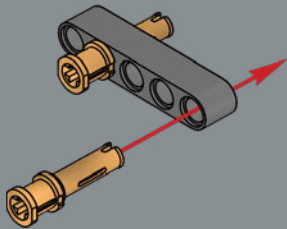

2

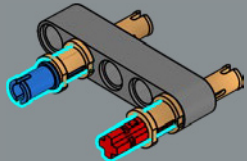

3

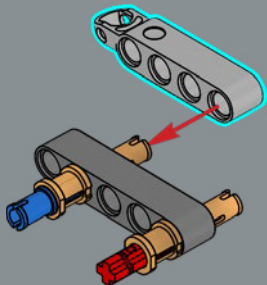

4

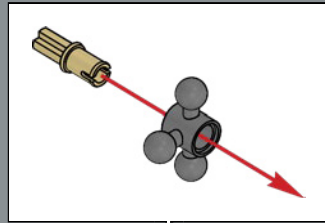
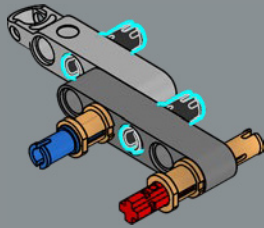

5

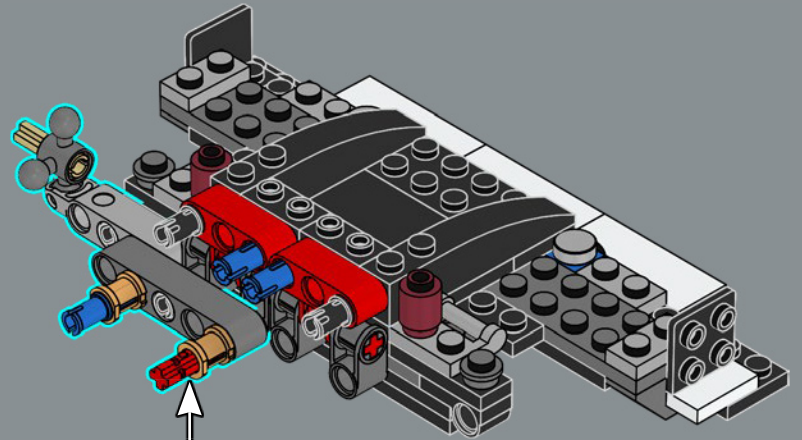
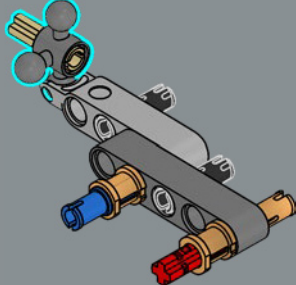

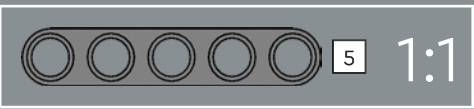
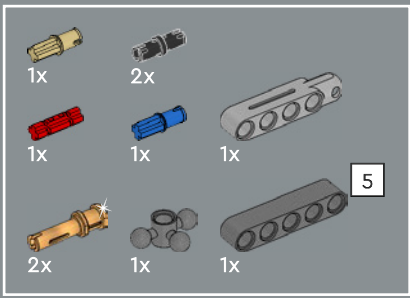

66

1

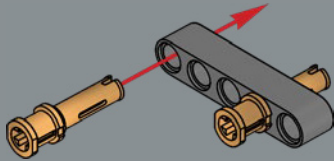

2

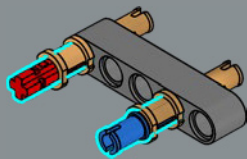

3

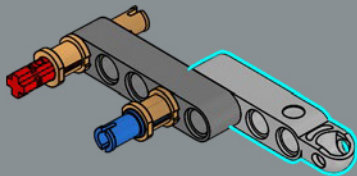

4

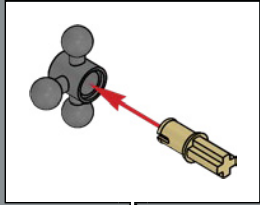
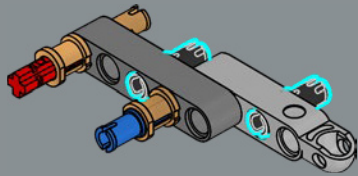

5

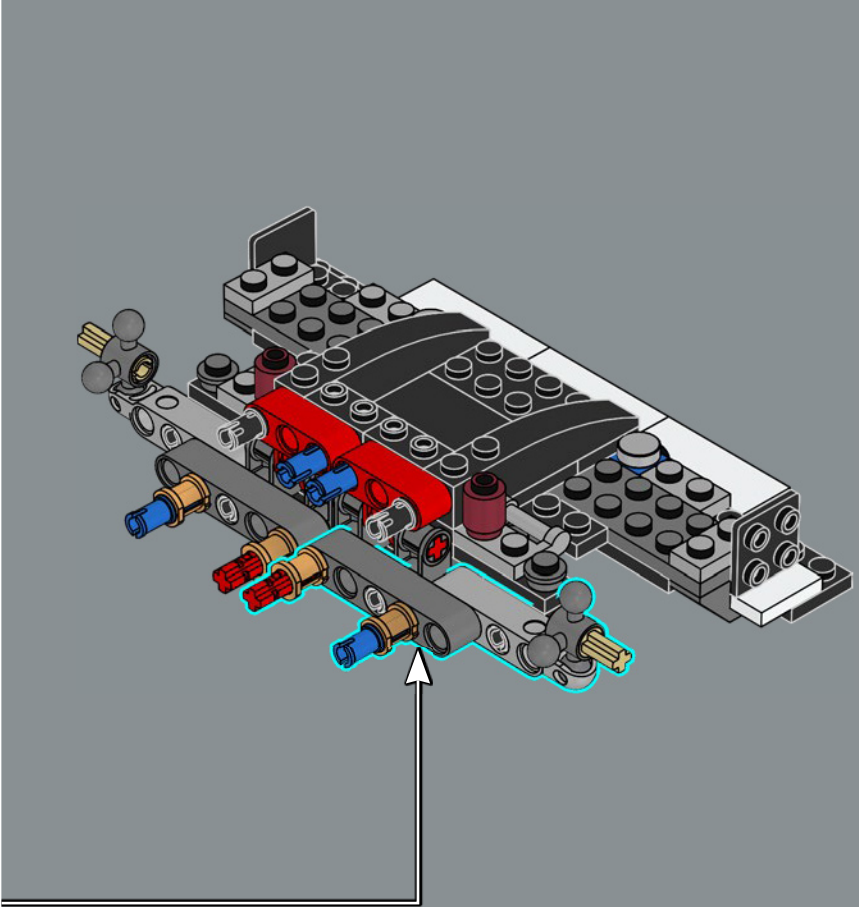
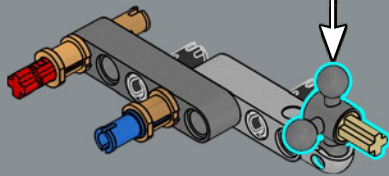

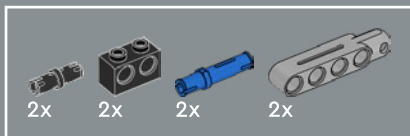

67

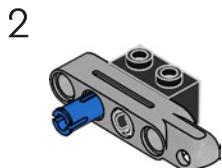
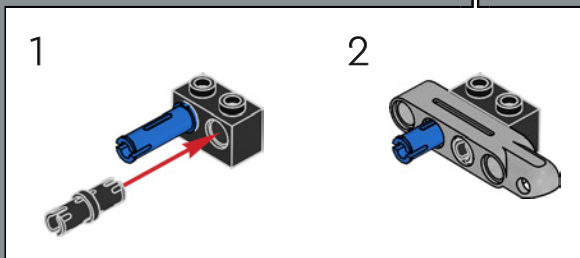
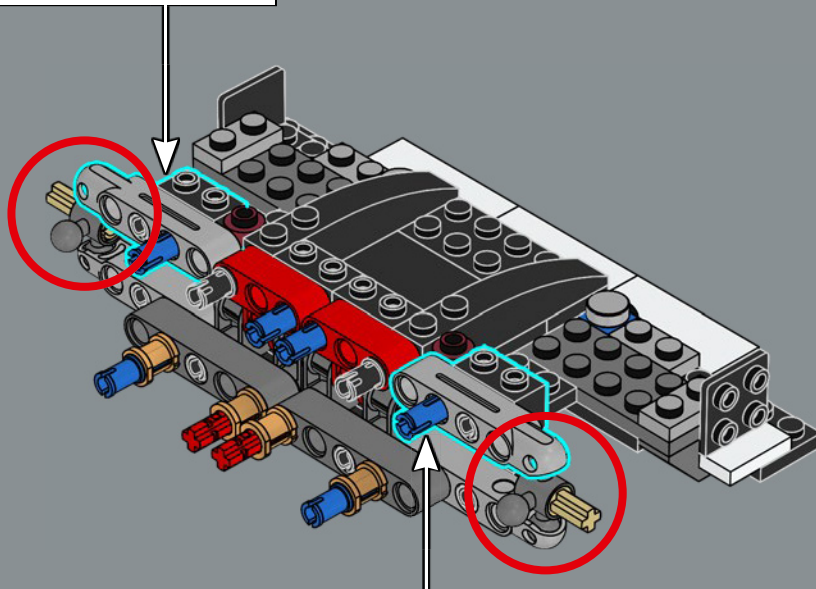
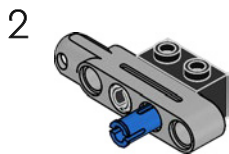
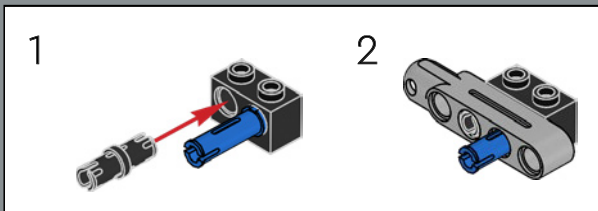

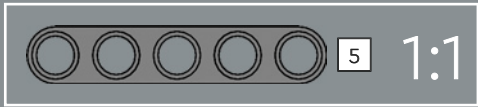
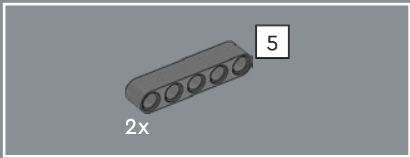

68

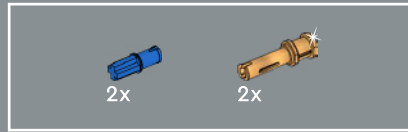
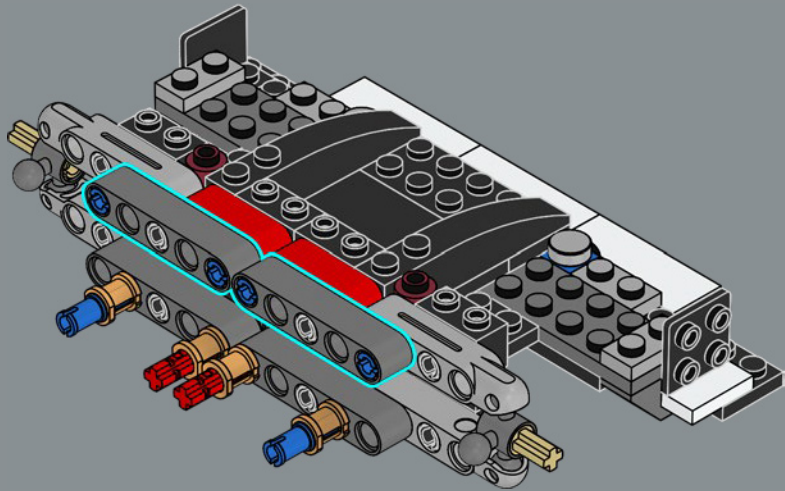

69

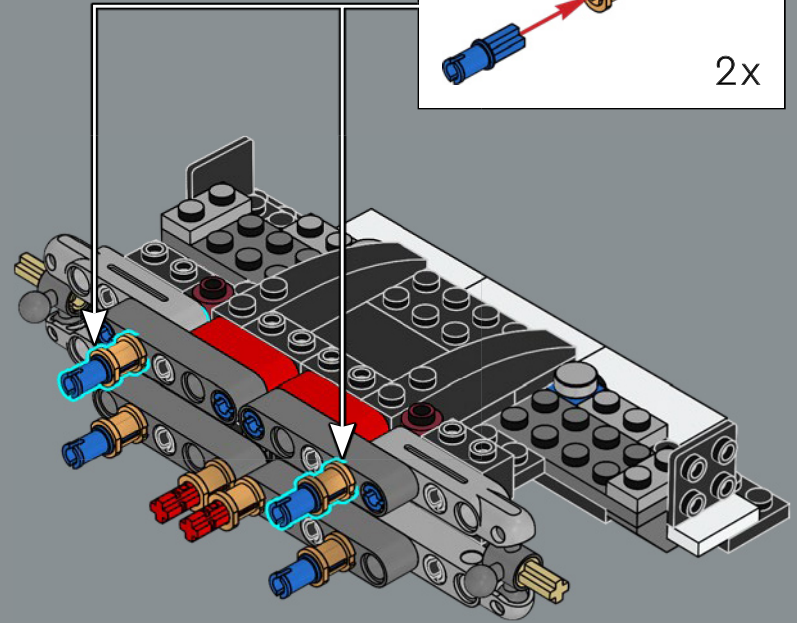
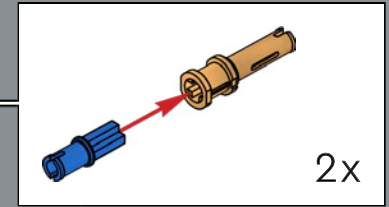



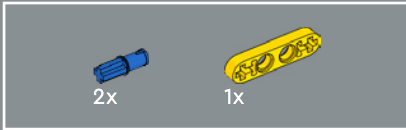
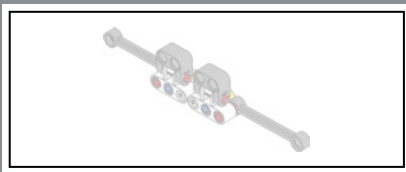

70

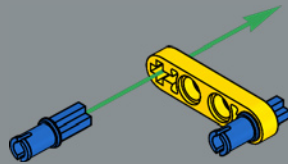

71

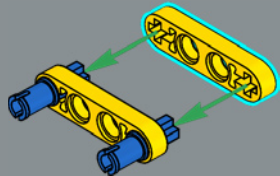

72

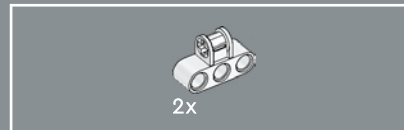
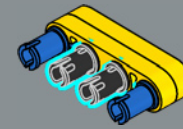

73

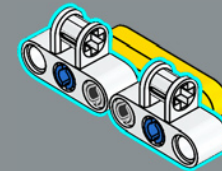

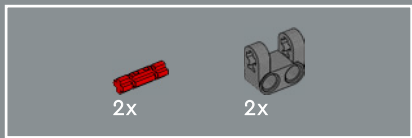

74

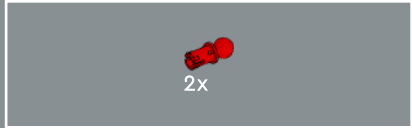
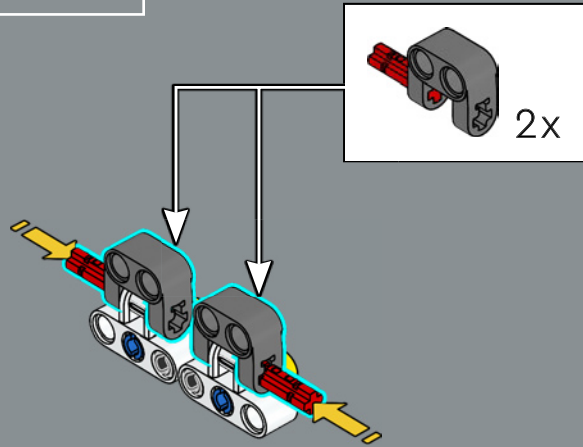

75

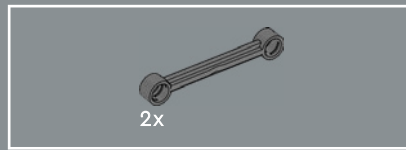
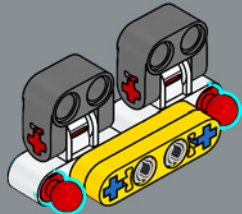

76

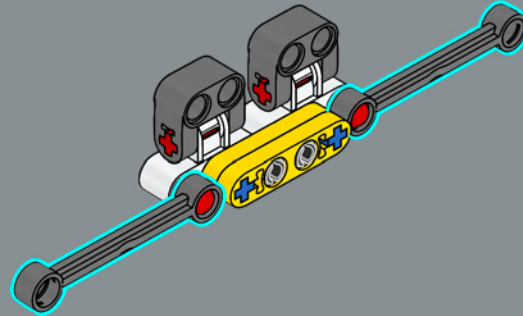

77

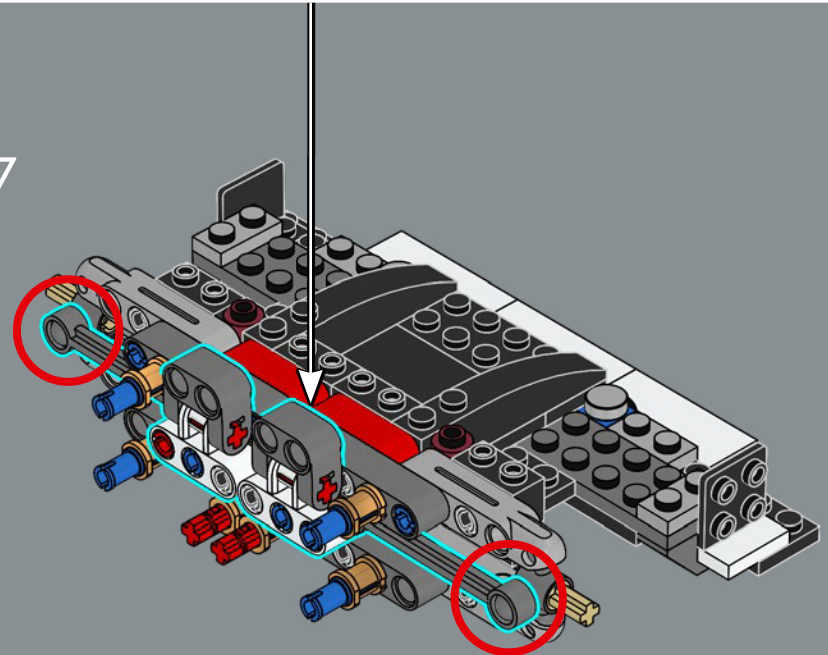

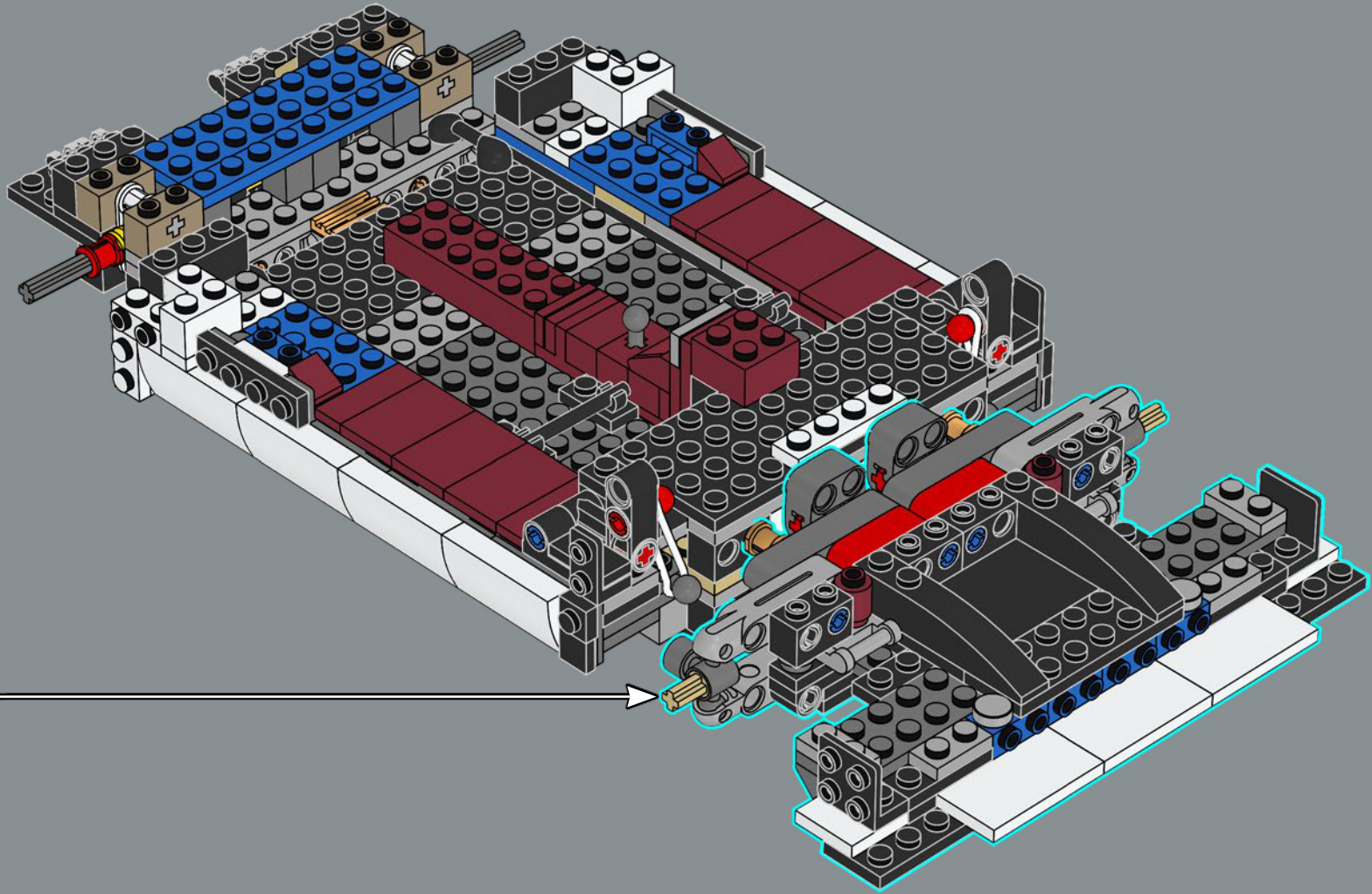

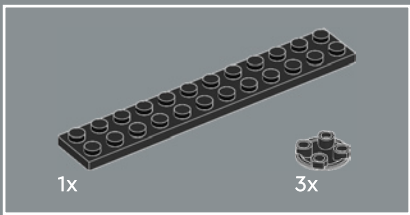

79

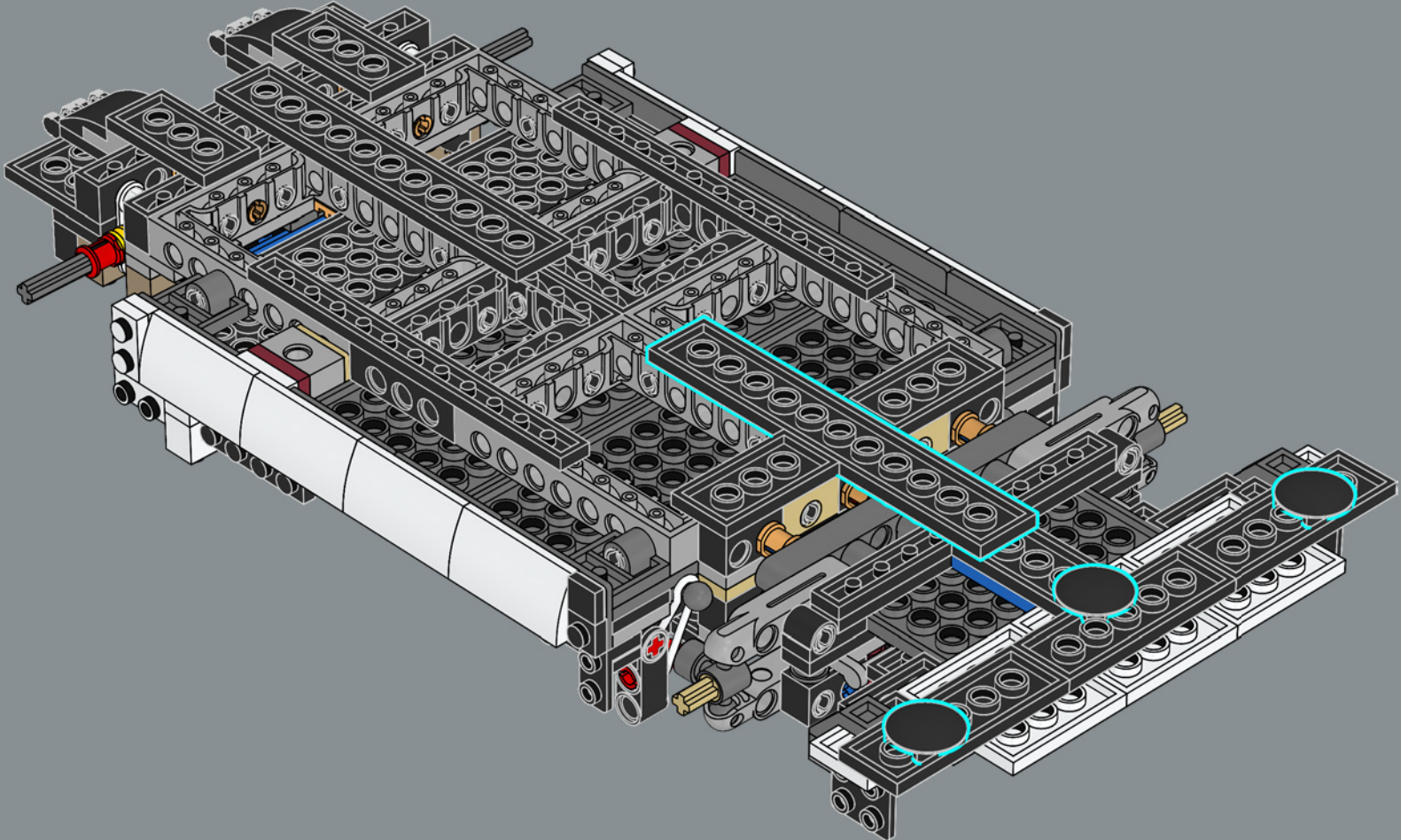



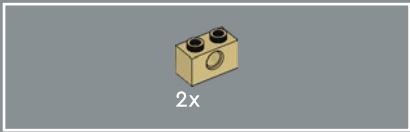

80

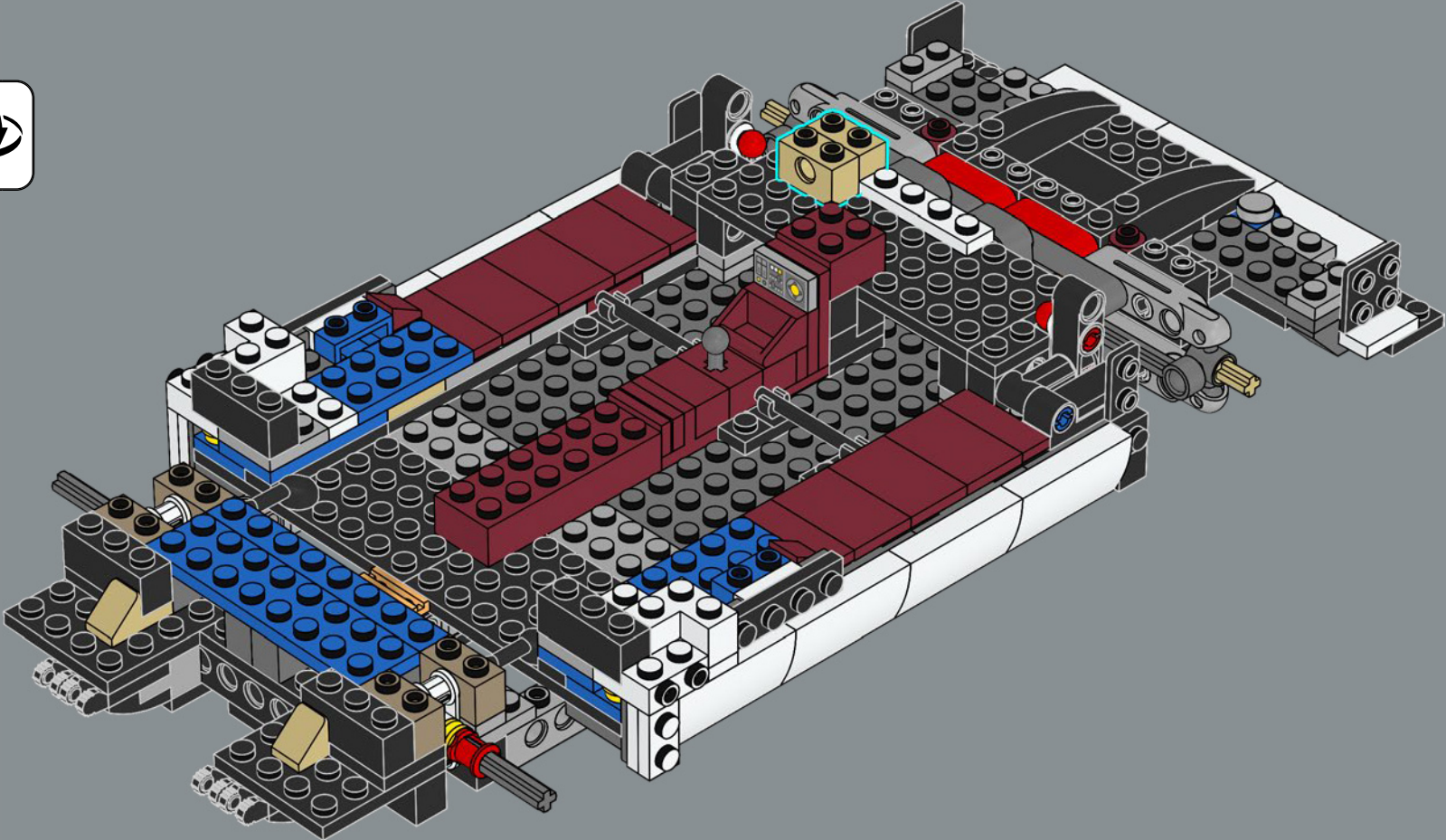

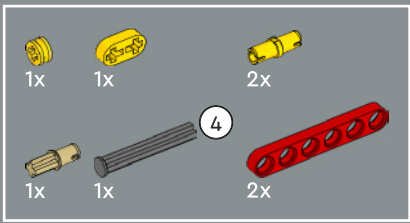

81

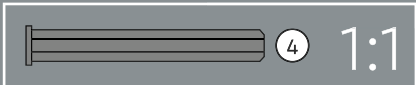
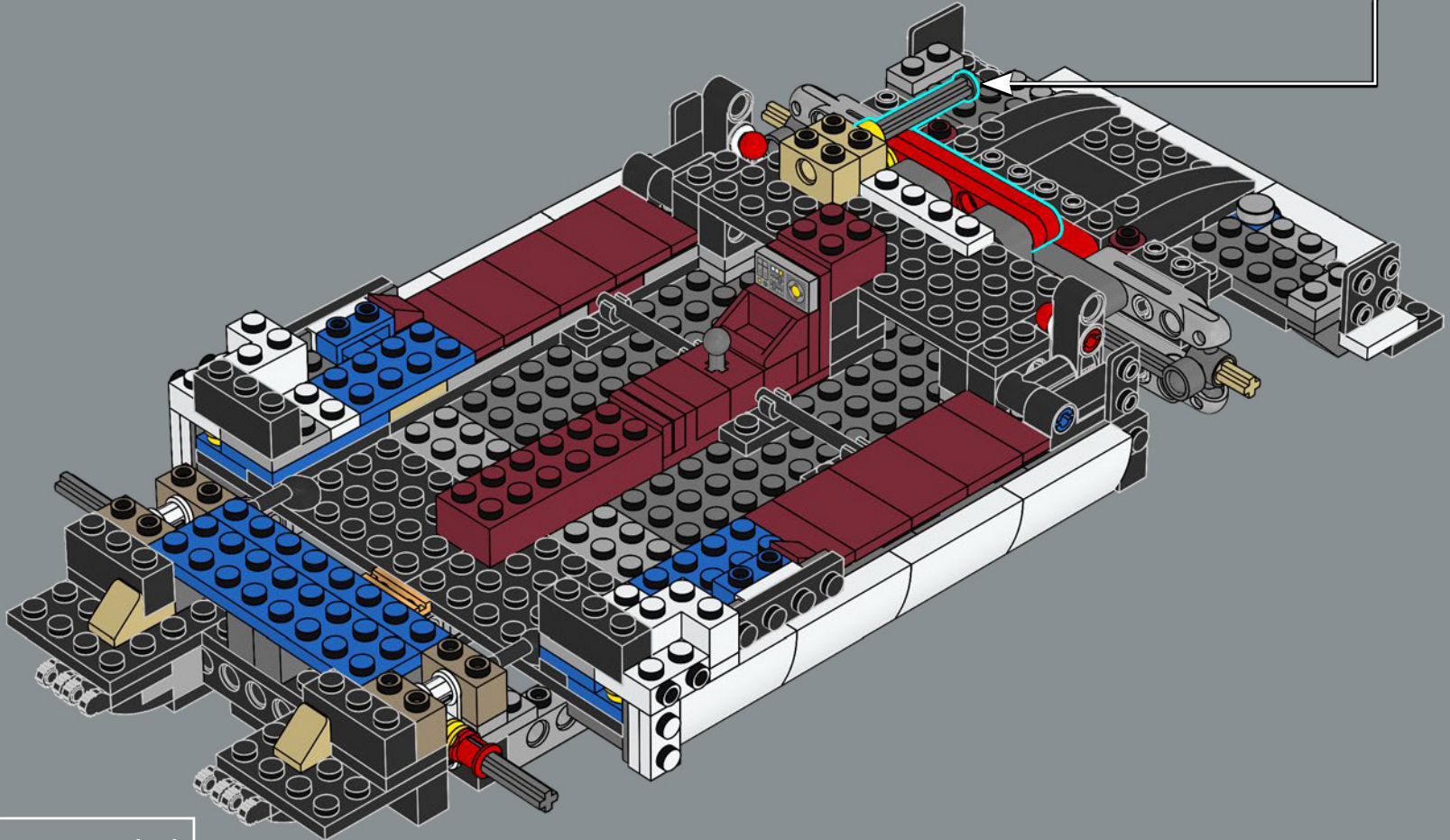
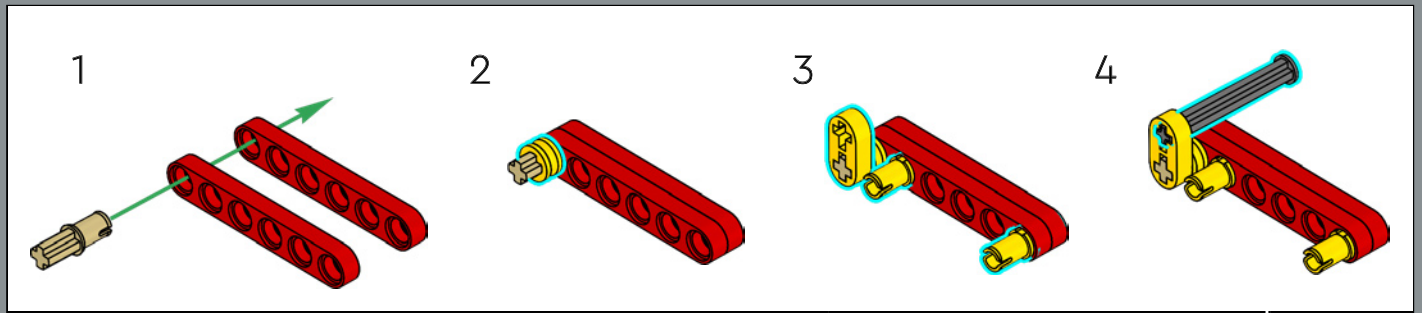





1x

82

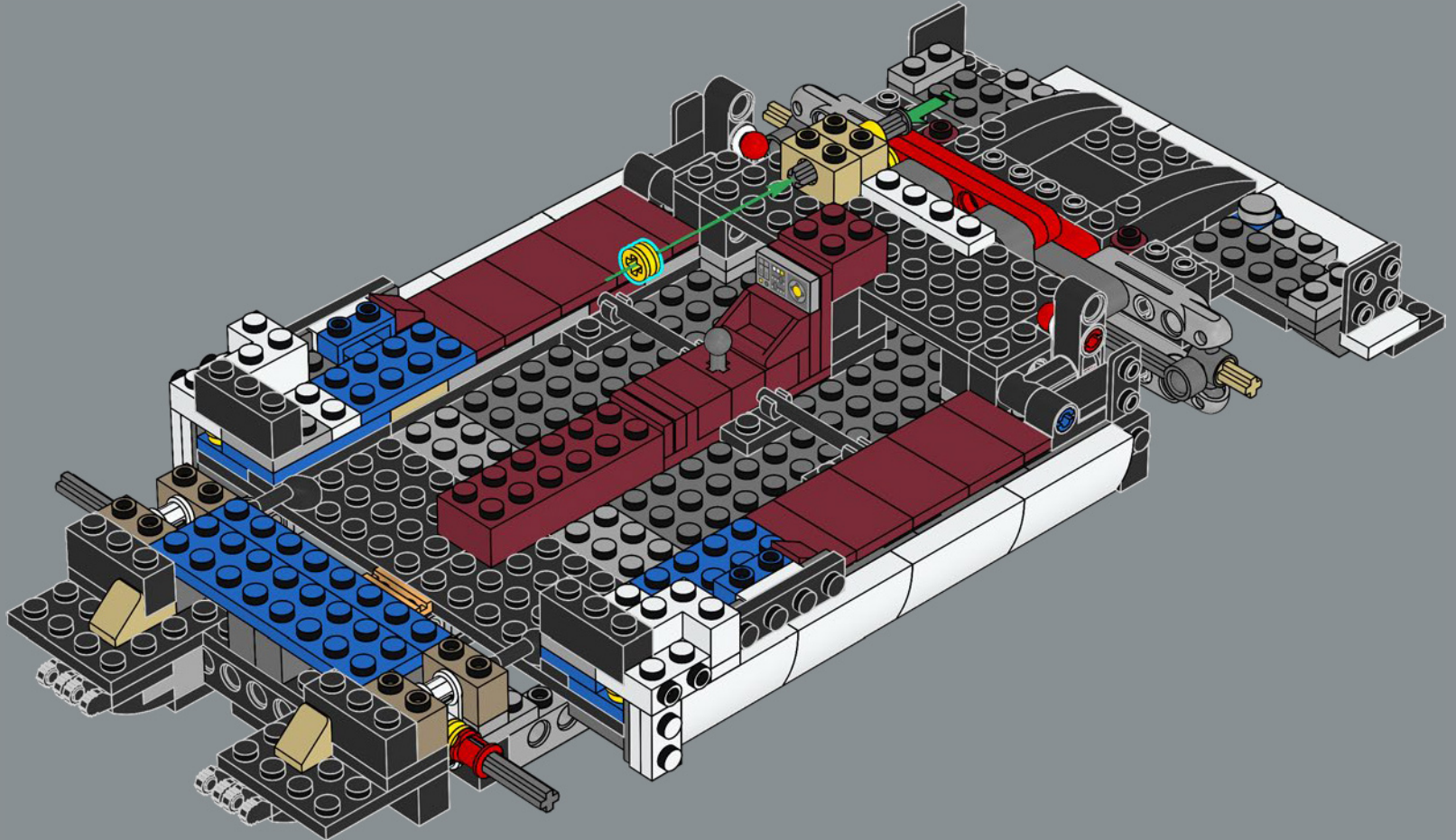

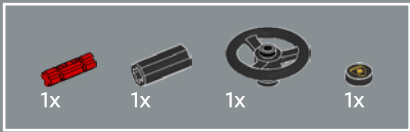

83

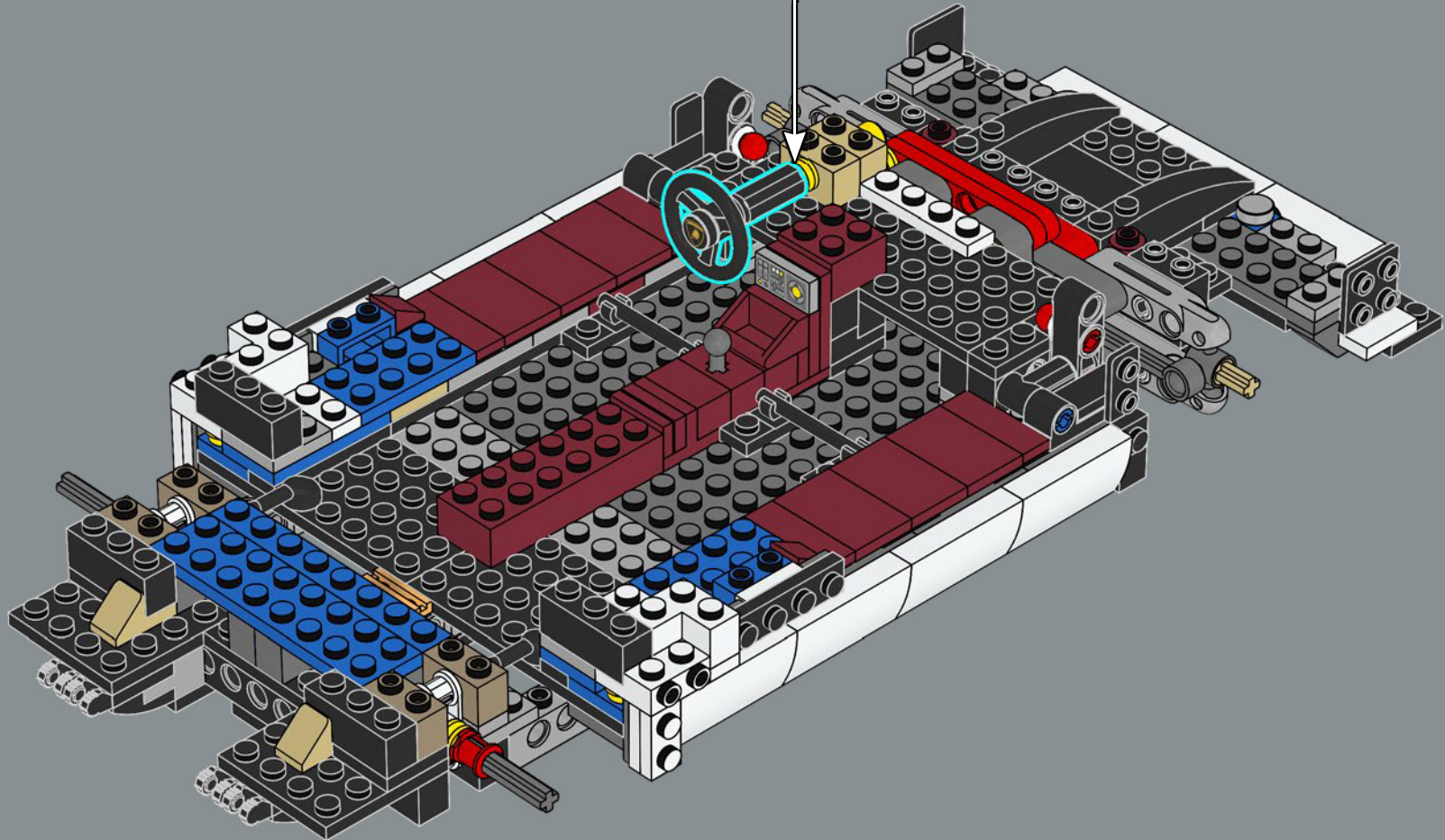
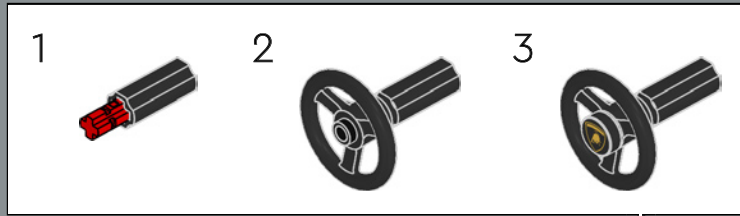



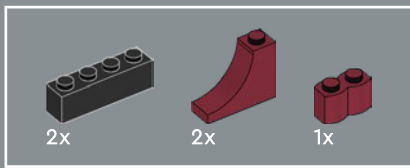

84

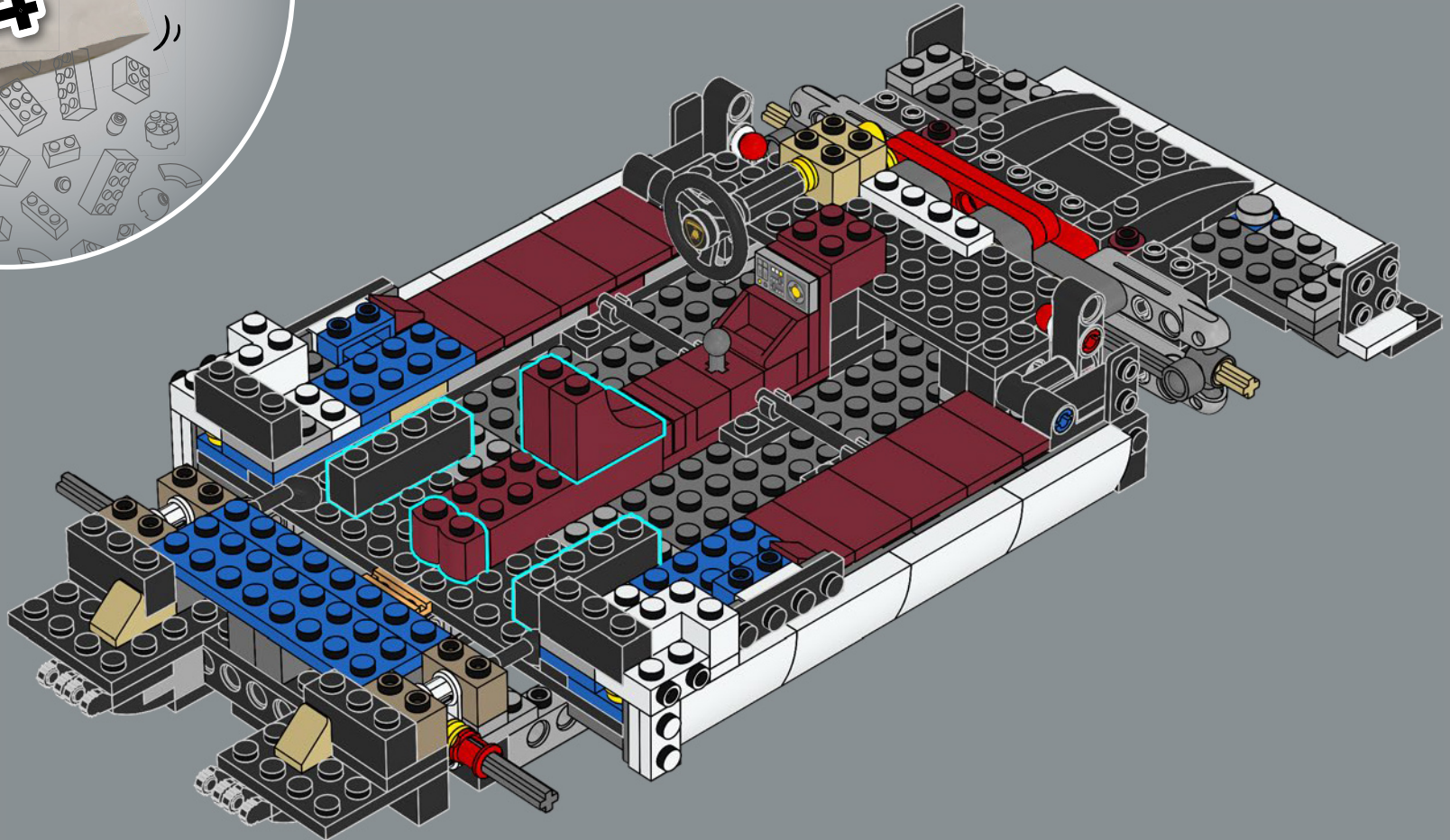

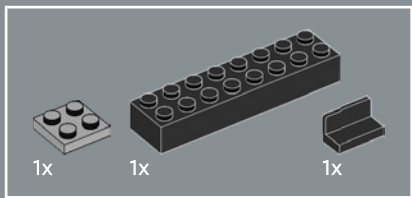

85

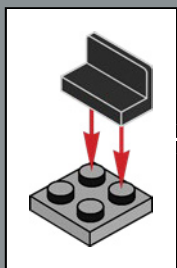
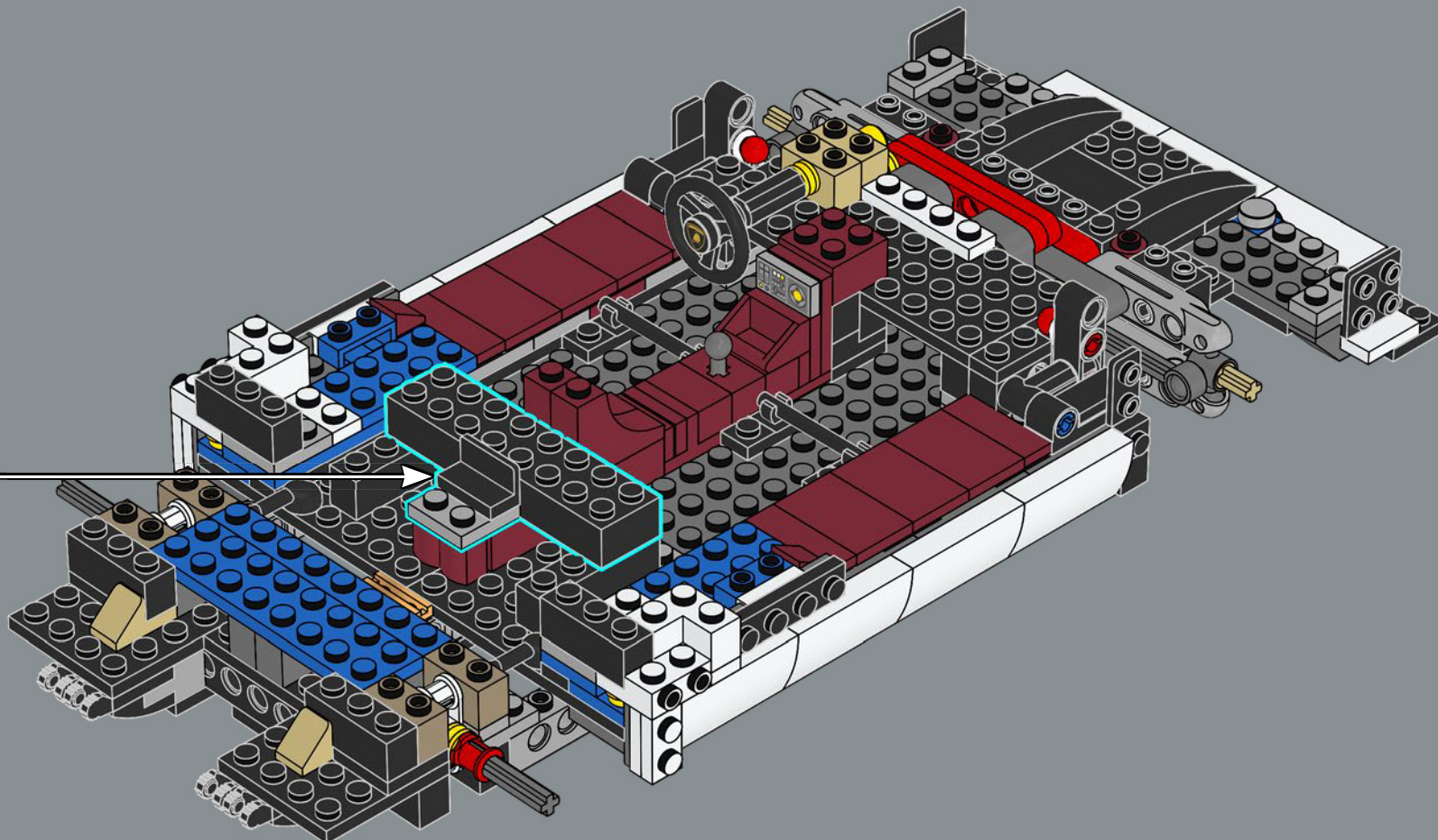



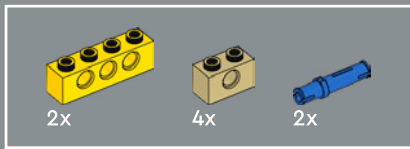

86

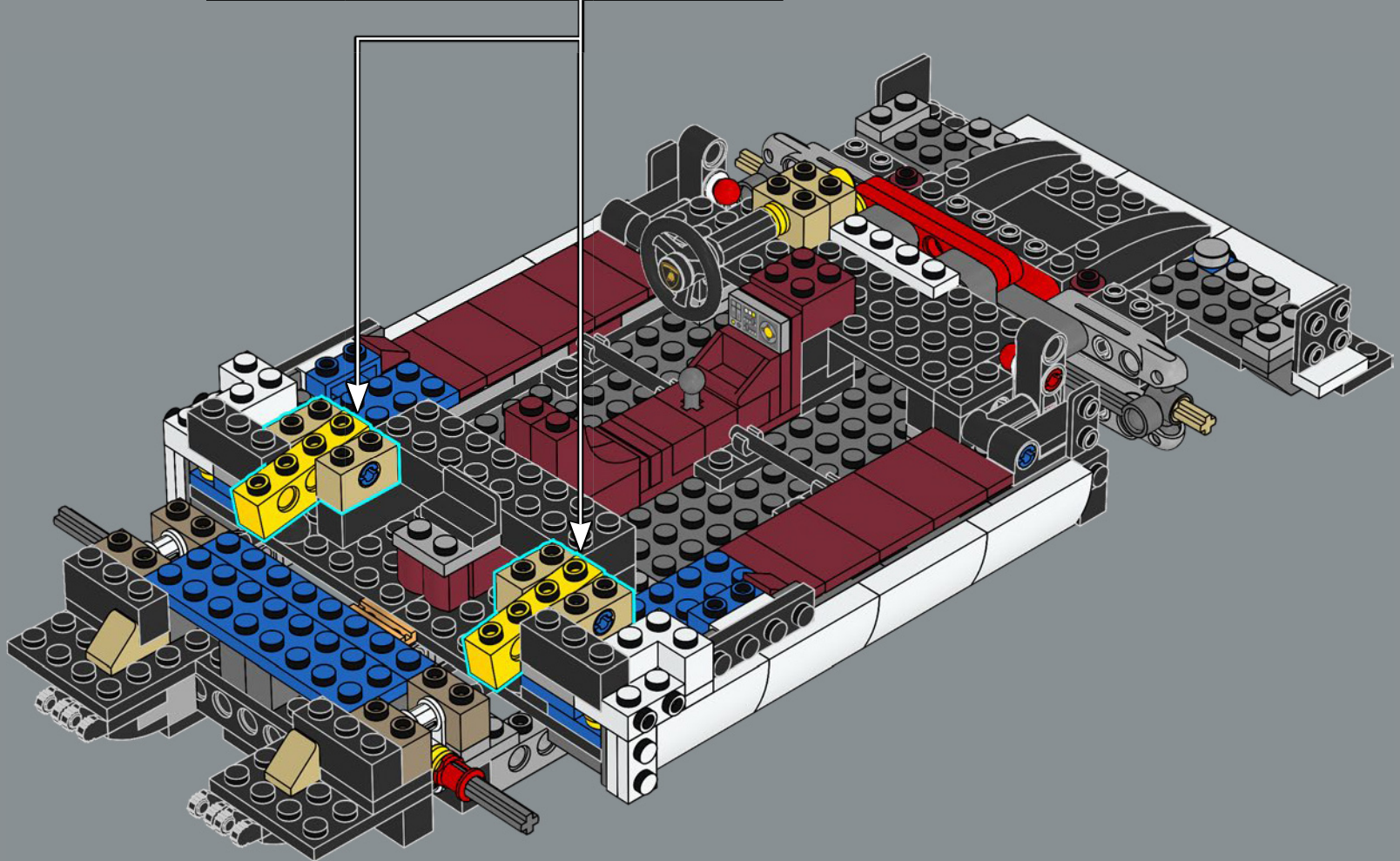
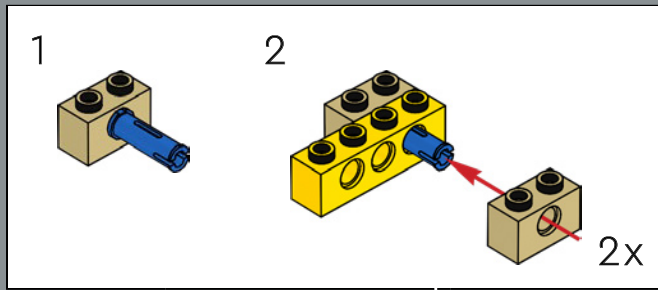

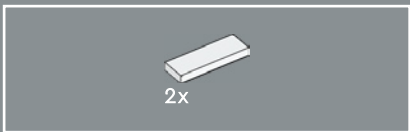

87

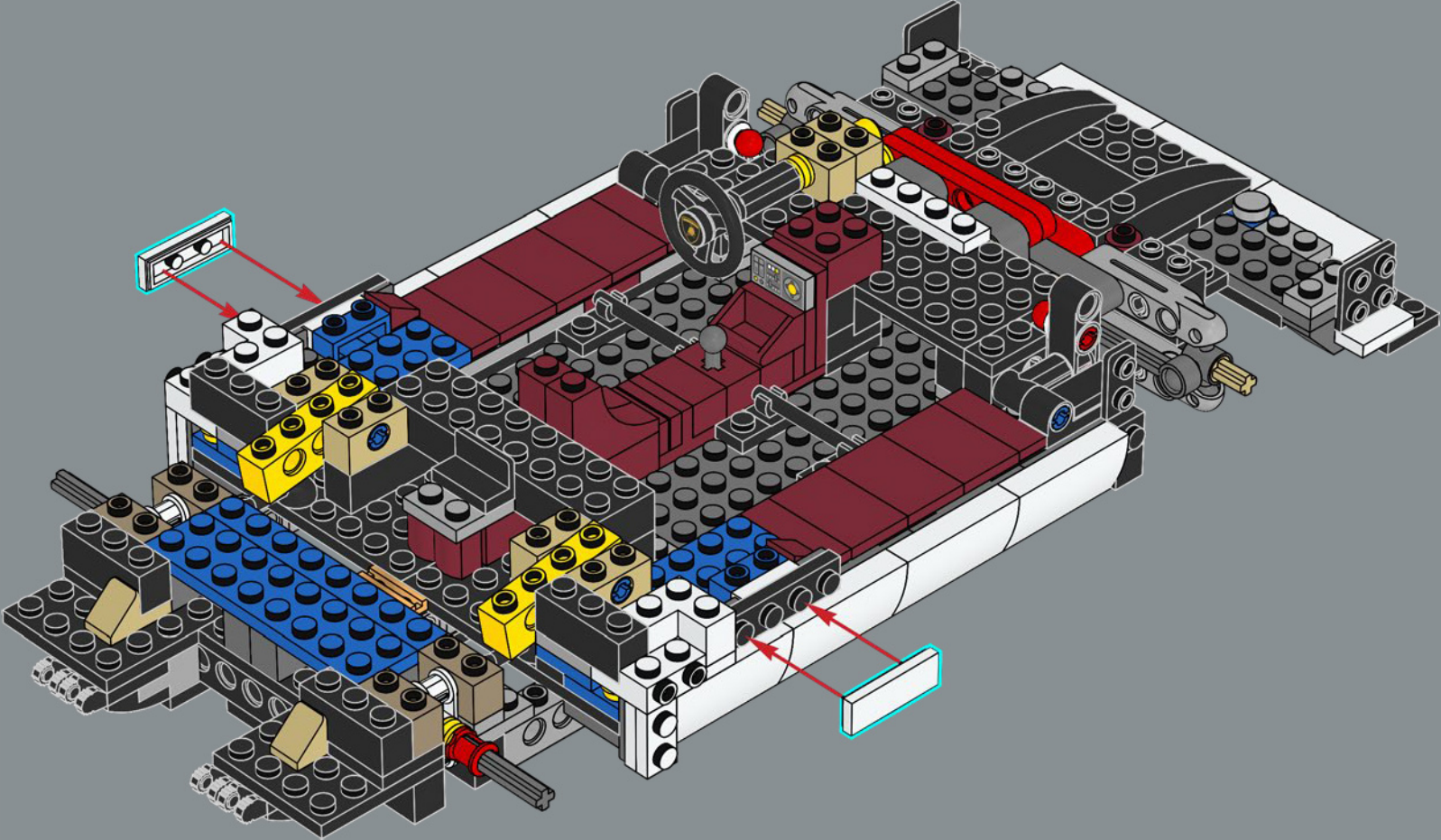



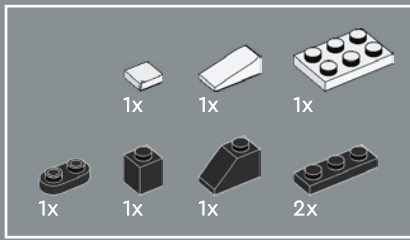

88

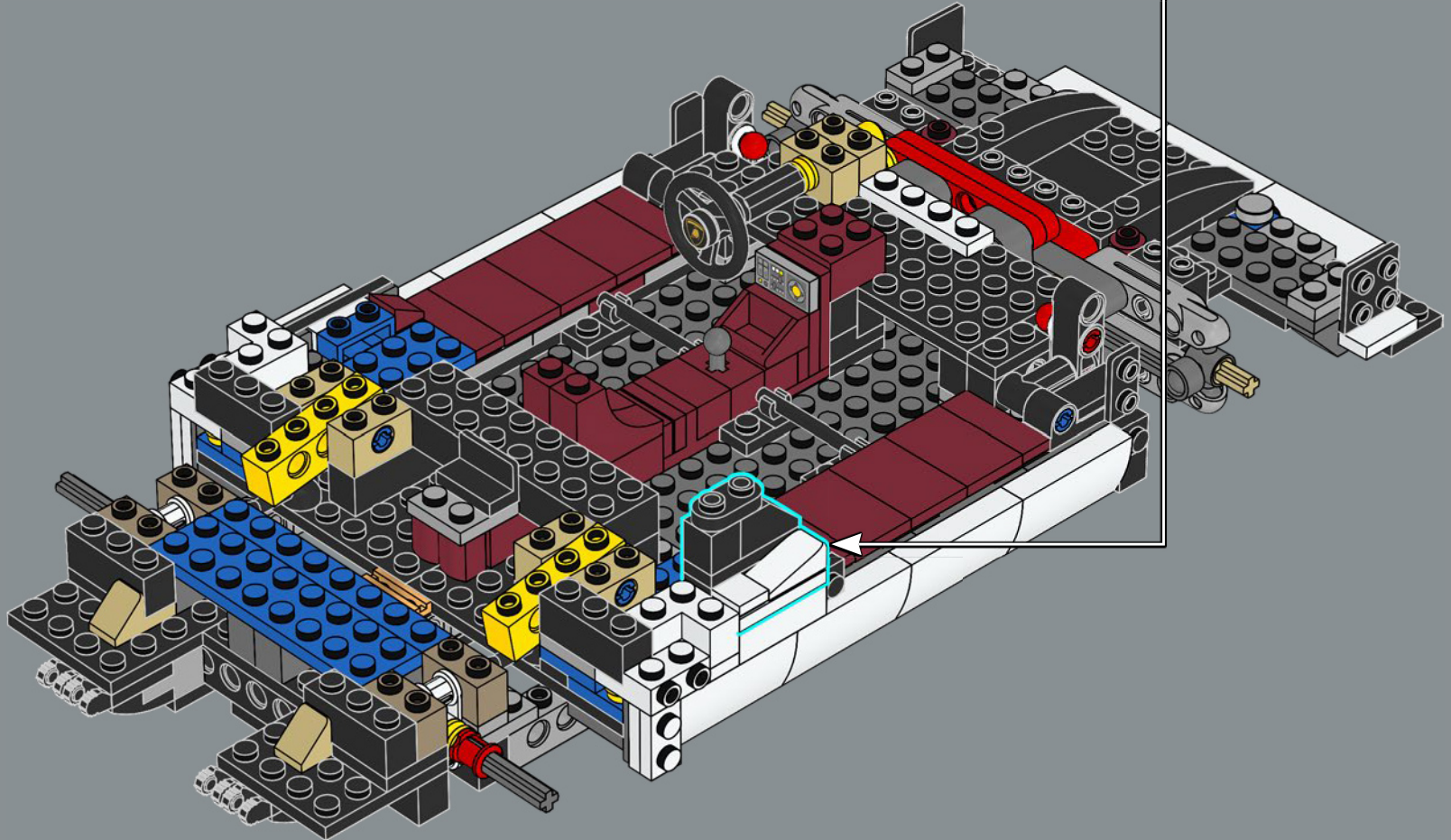
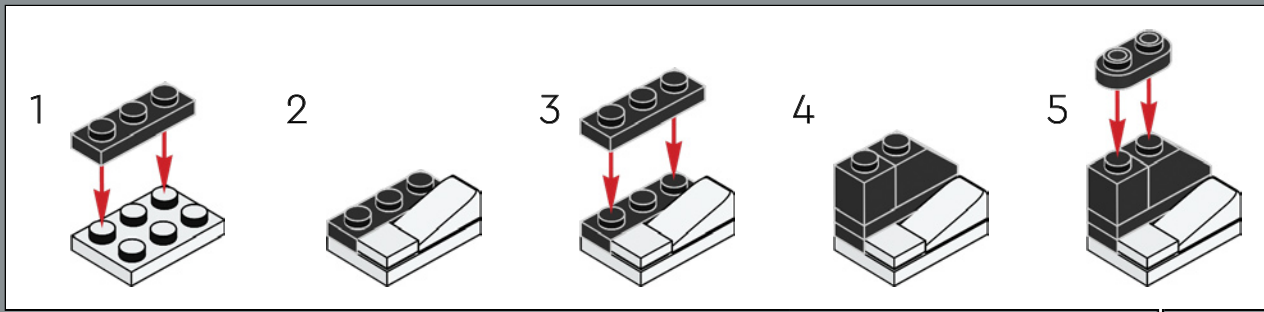

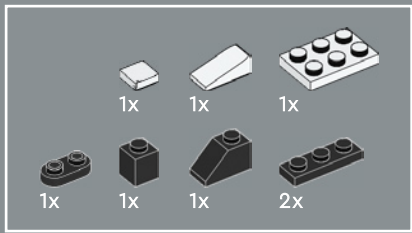

89

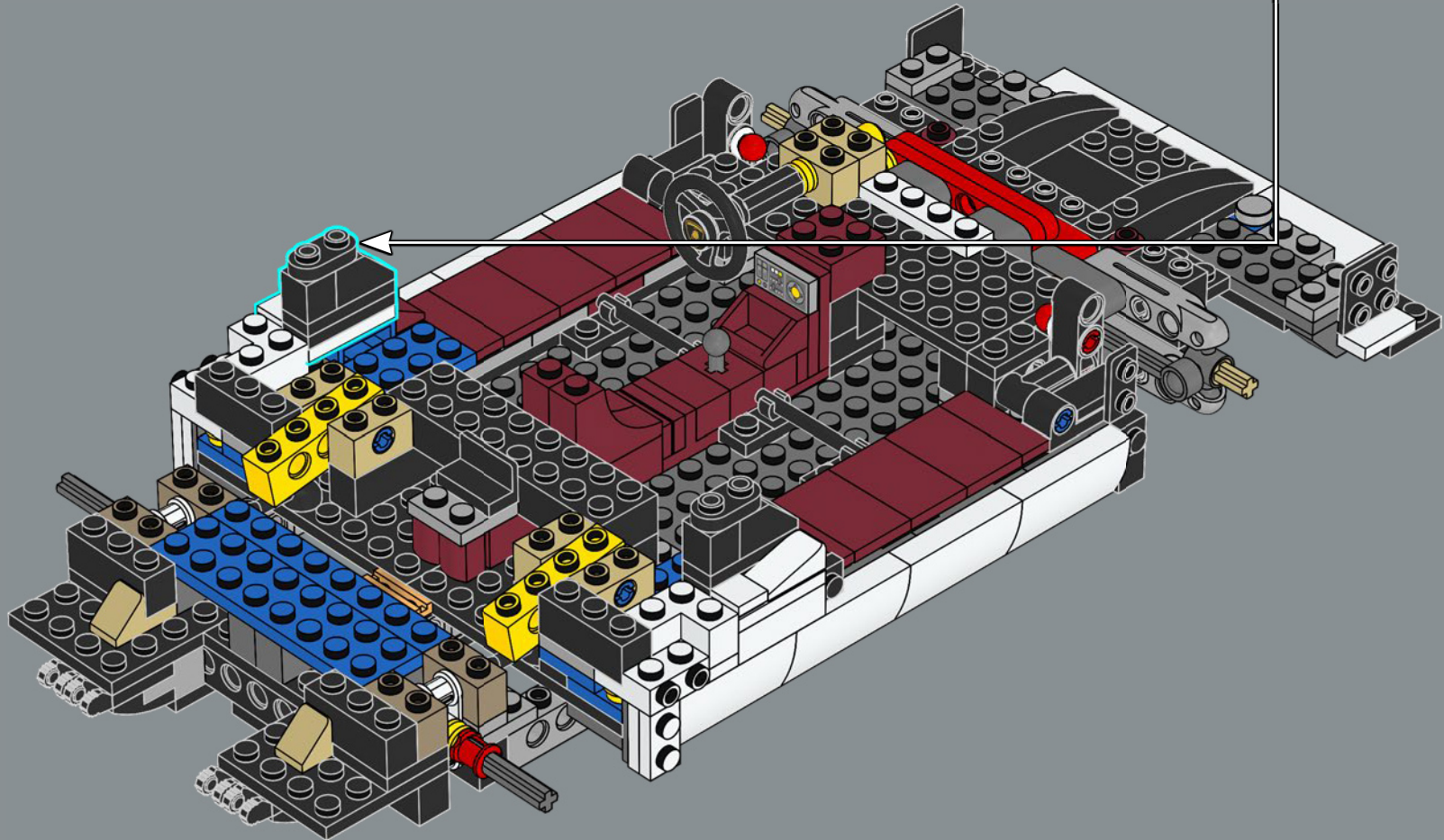
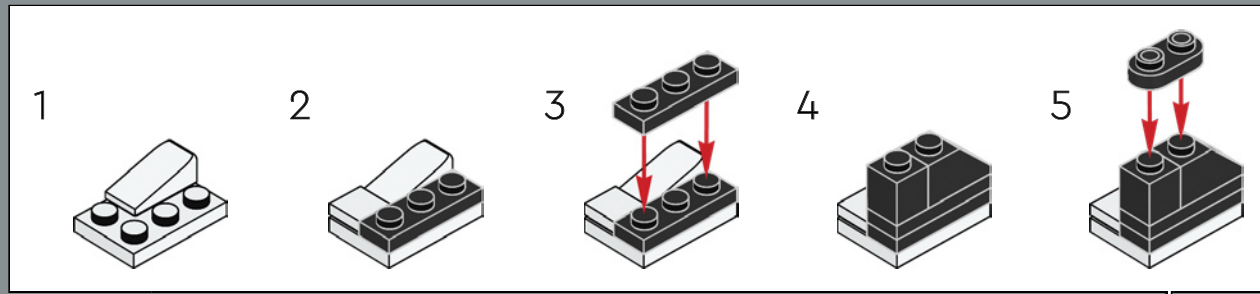



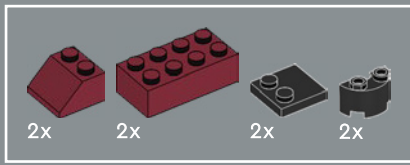

90

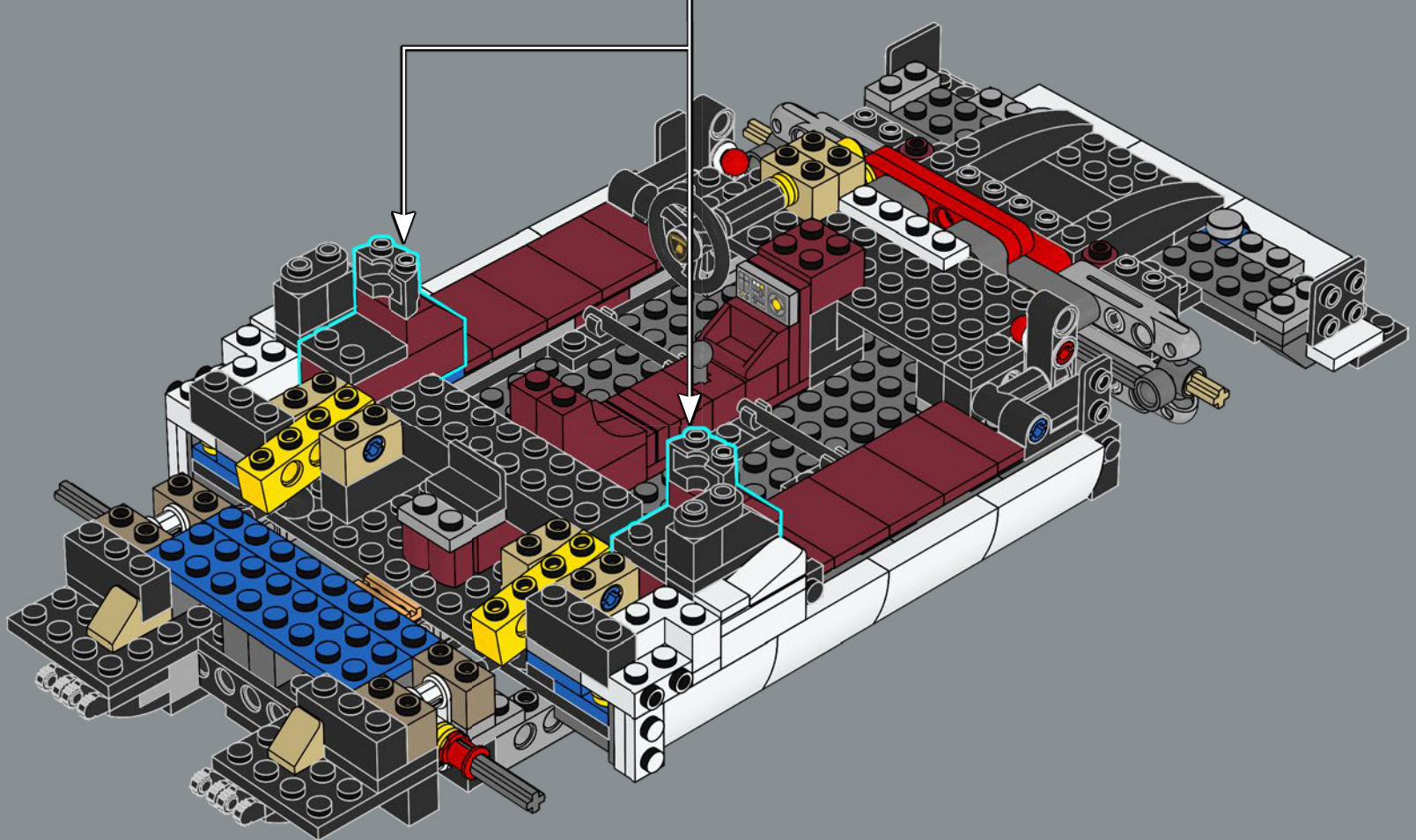
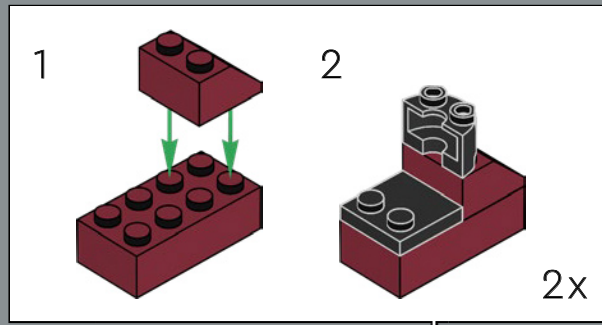

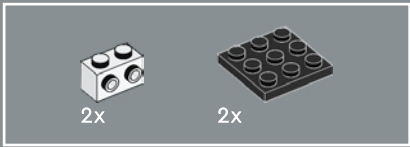

91

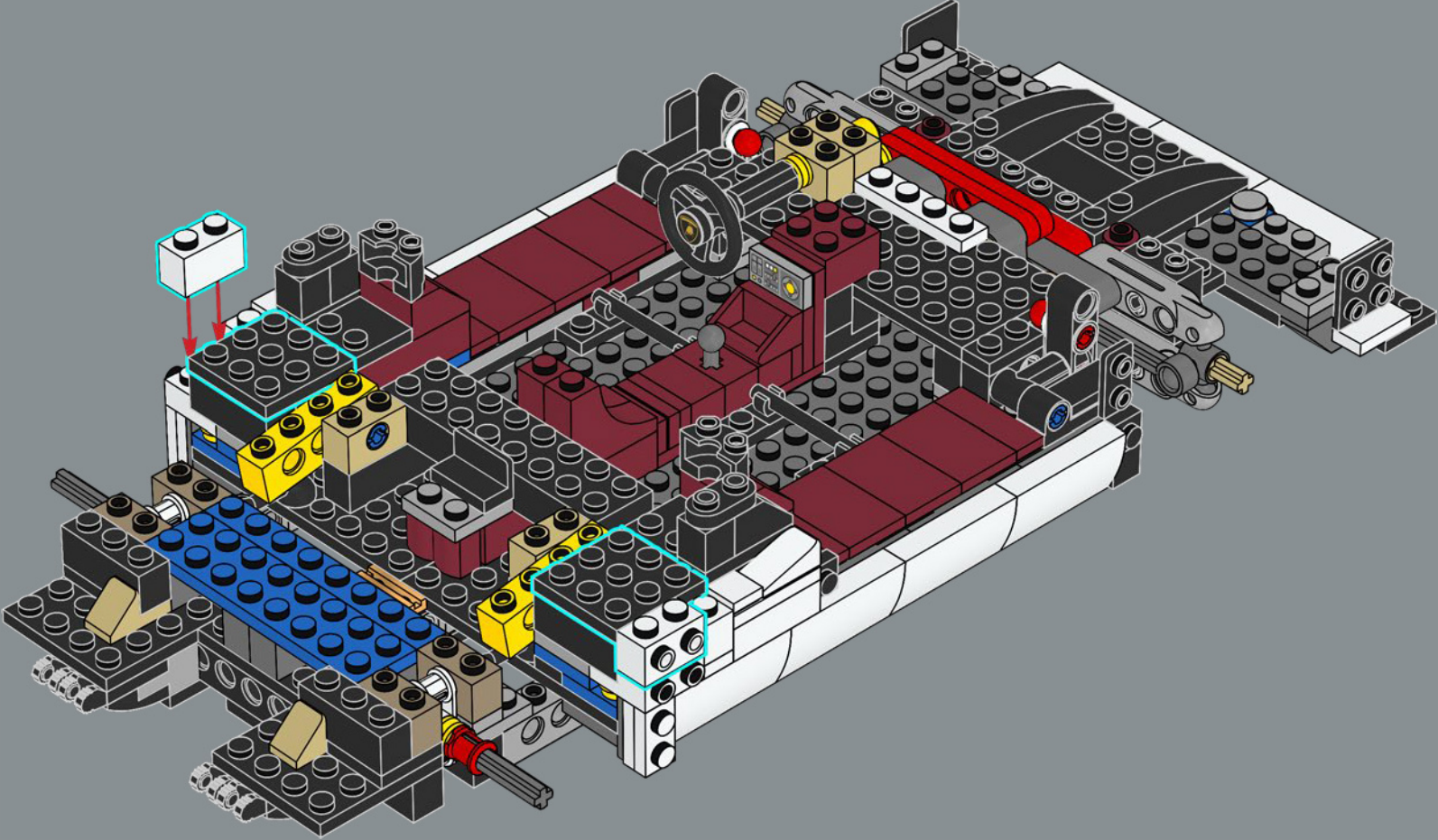



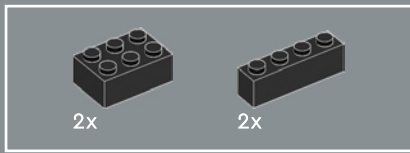

92

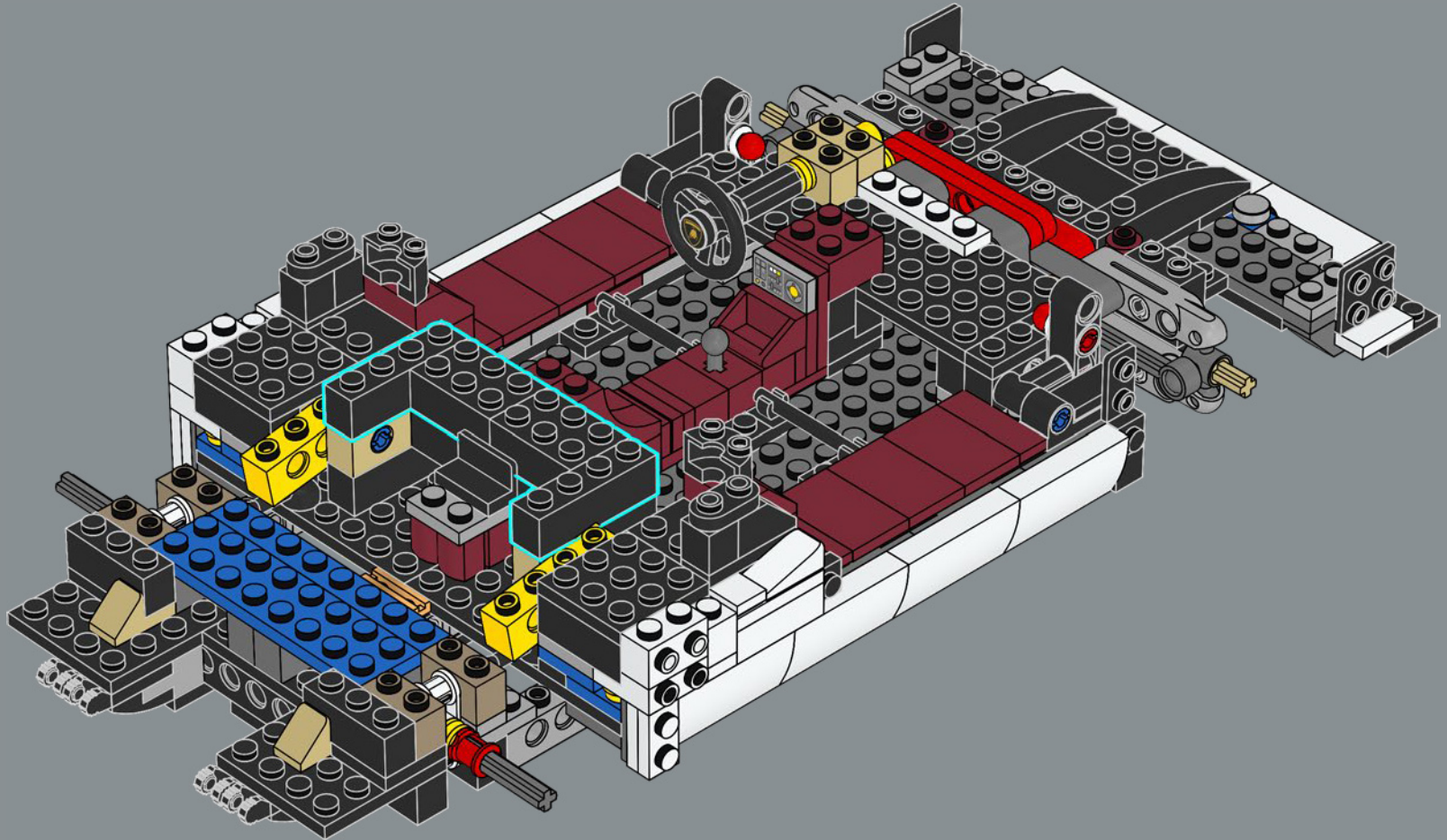

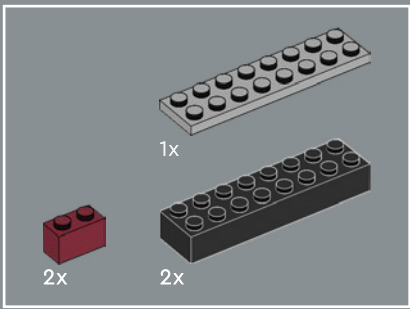

93

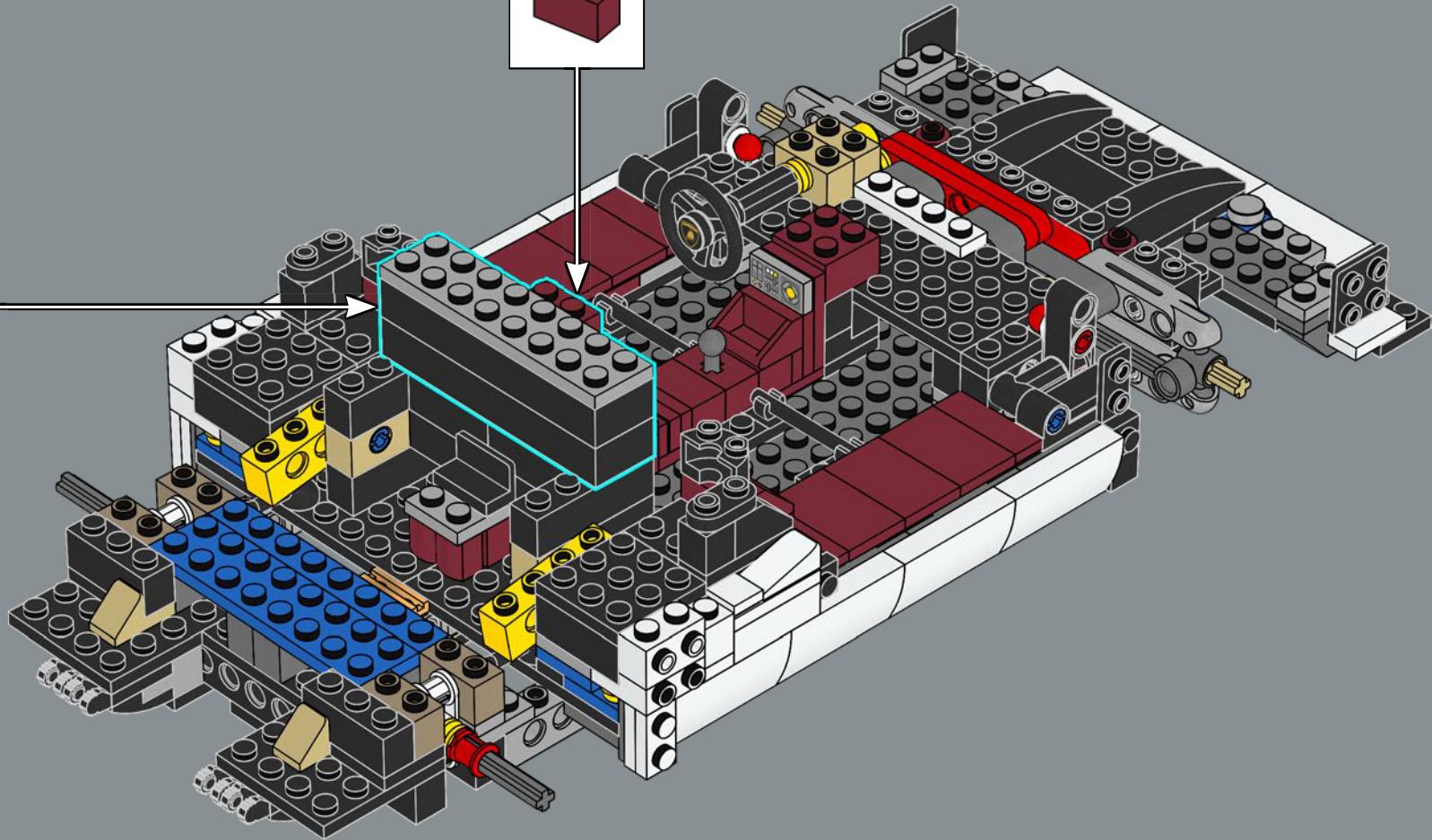
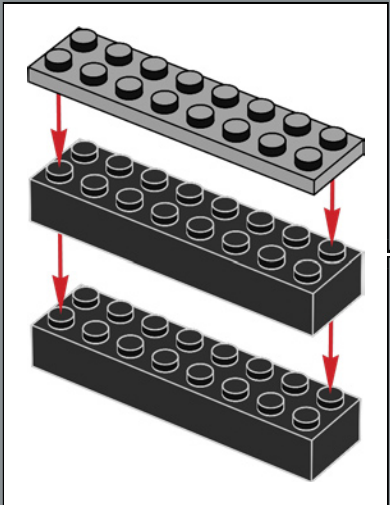
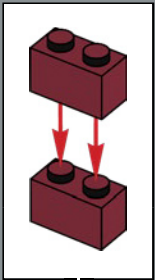

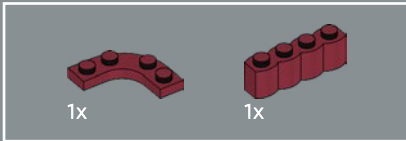
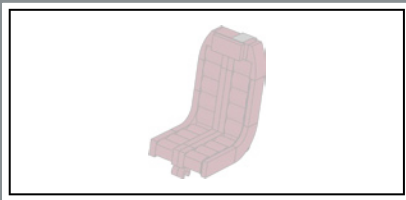

94

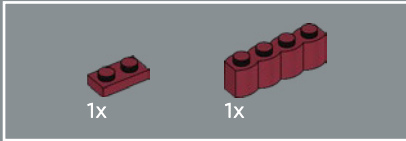
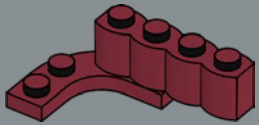

95

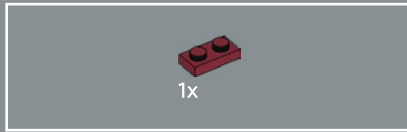
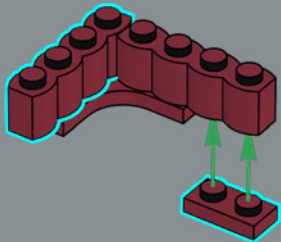

96

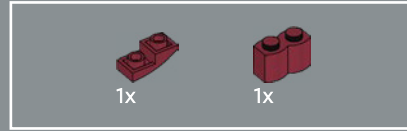
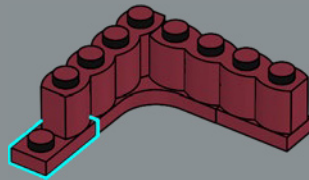

97

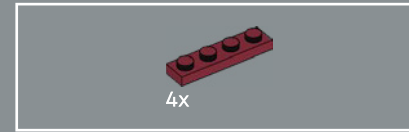
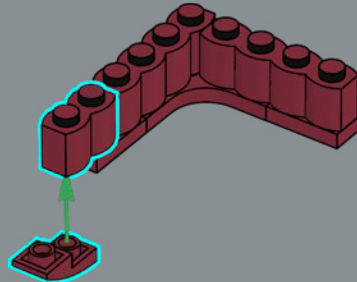

98

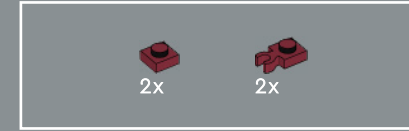
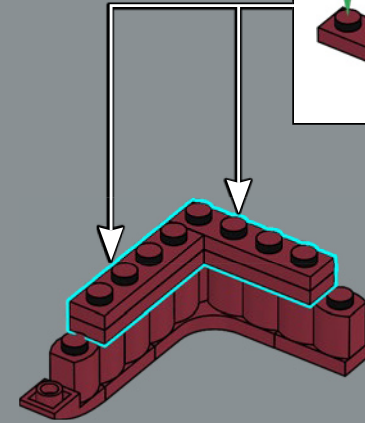
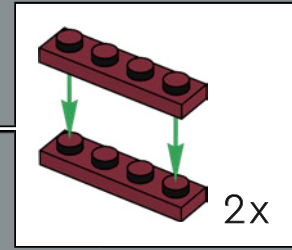

99

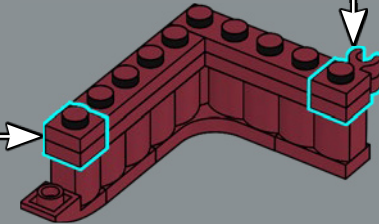
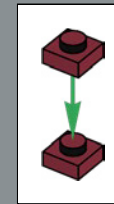
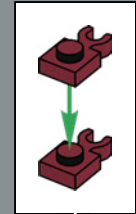



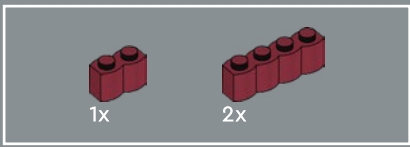

100

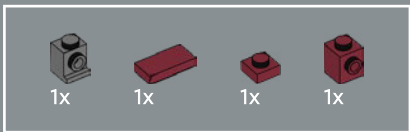
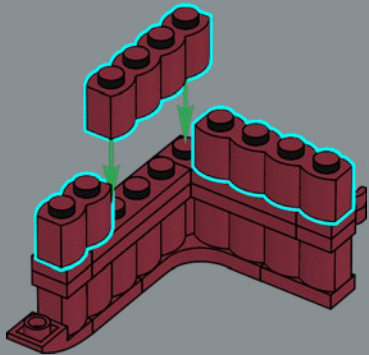

101

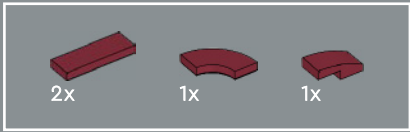
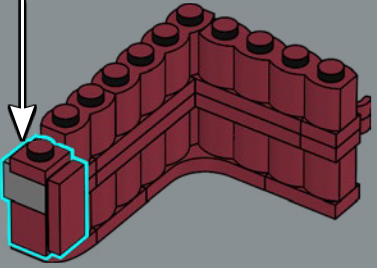
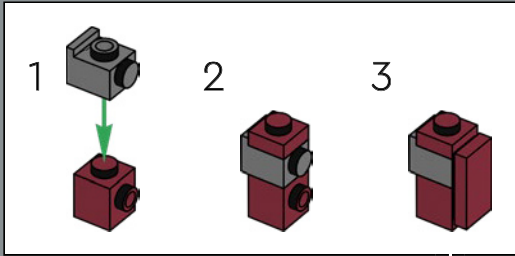

102

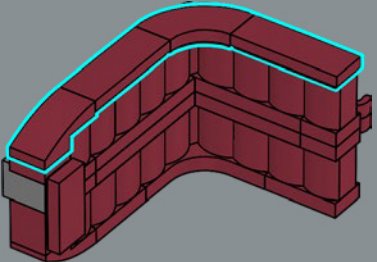

103

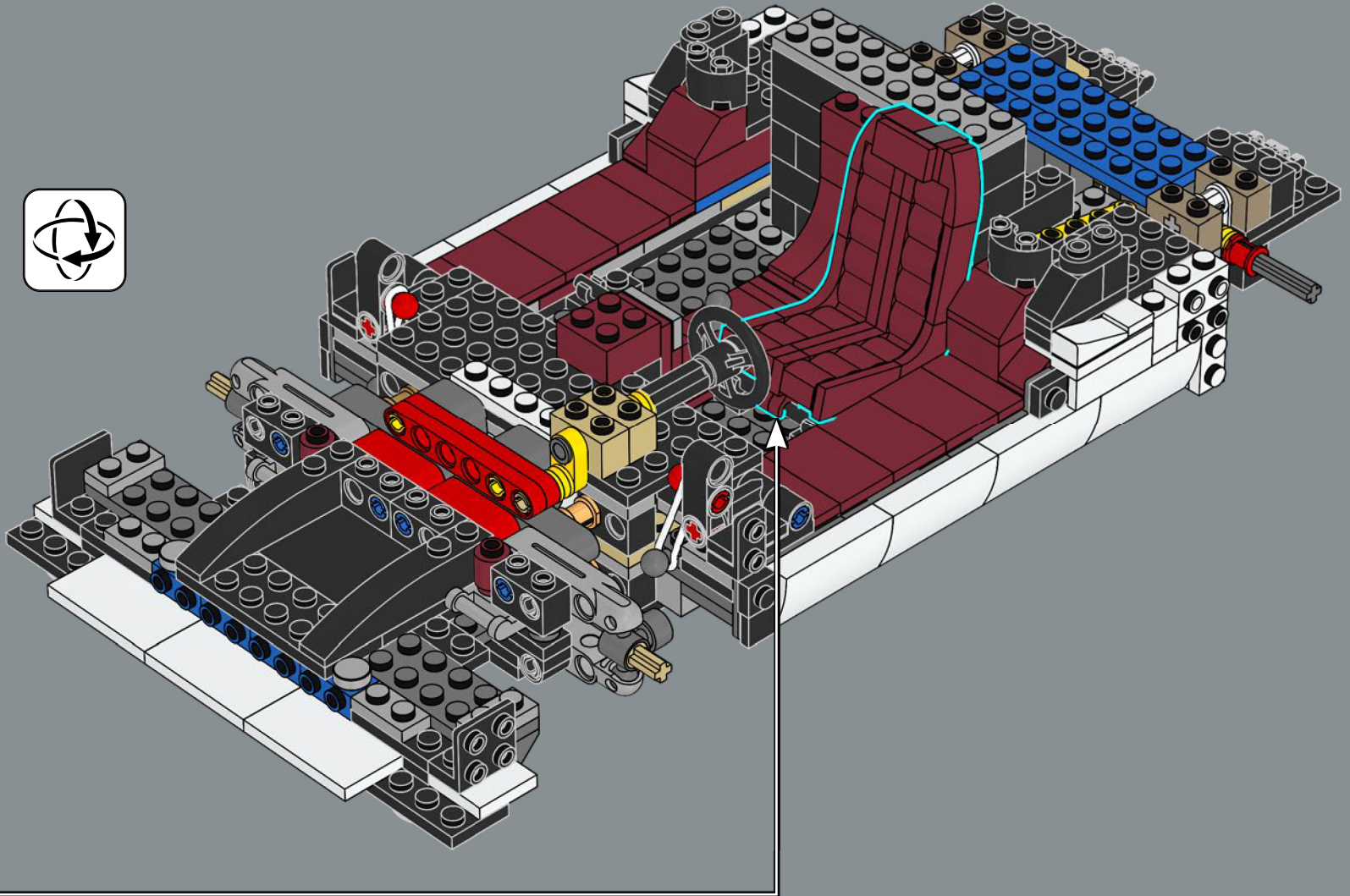

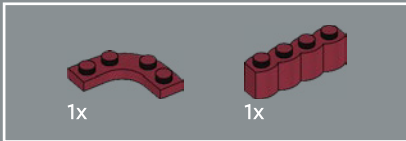

104

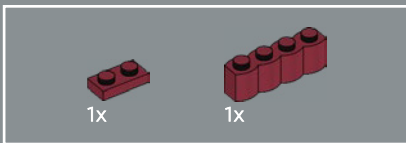
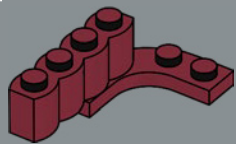

105

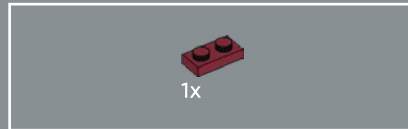
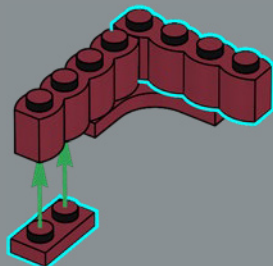

106

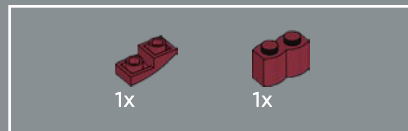
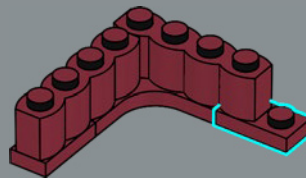

107

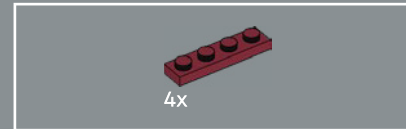
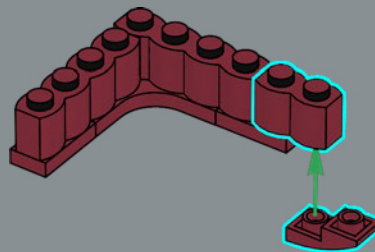

108

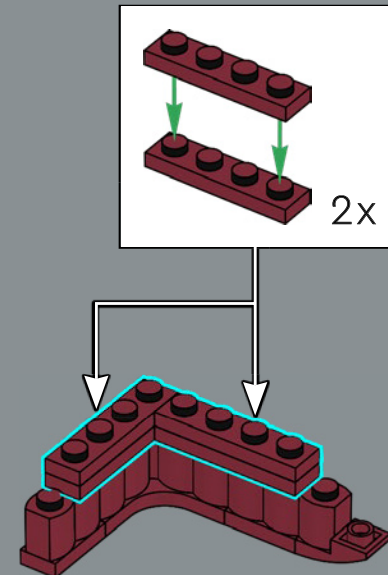





109

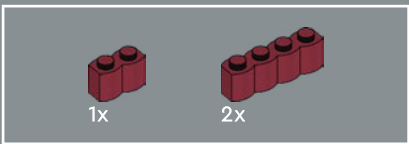
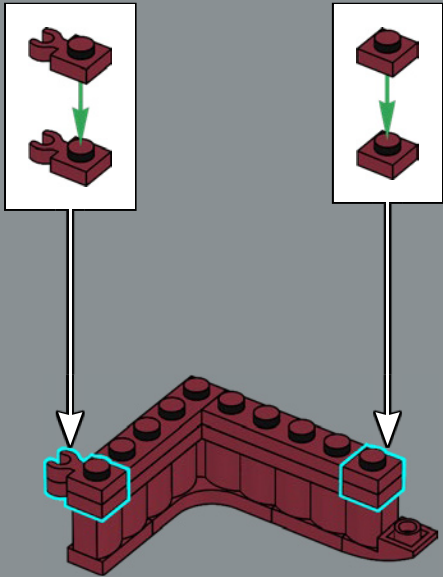

110

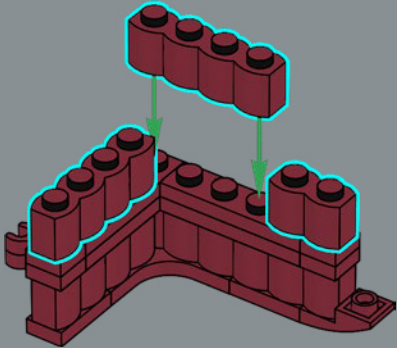

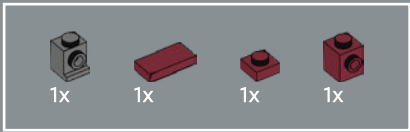

111

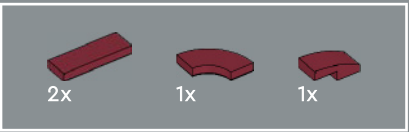
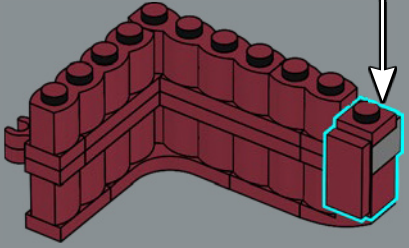
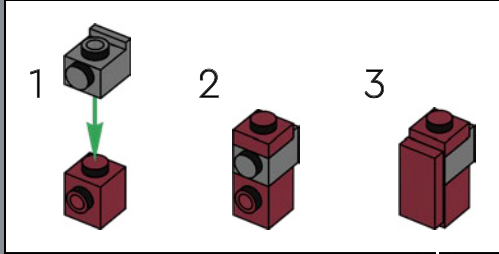

112

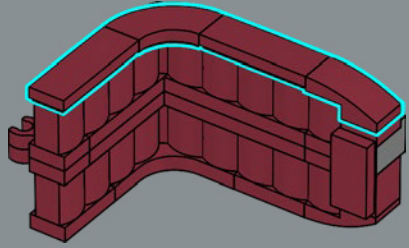

113

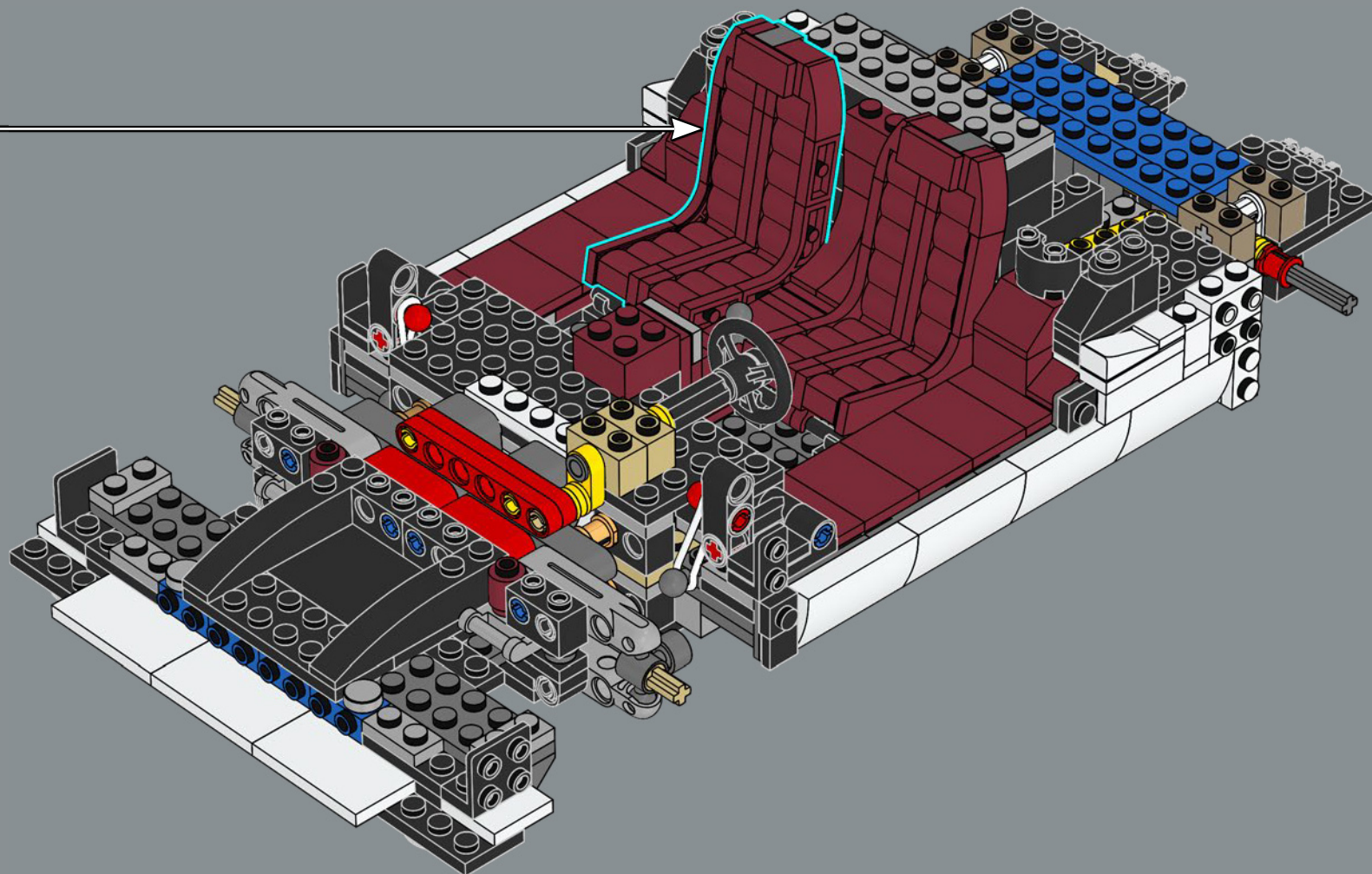



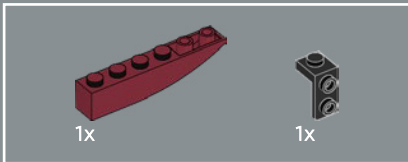
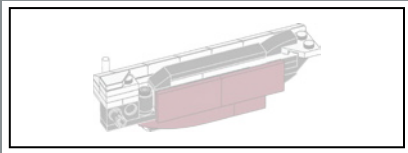

114

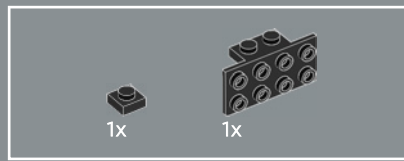
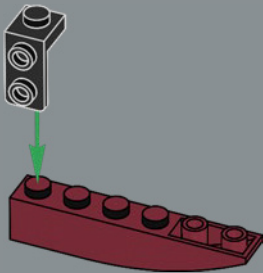

115

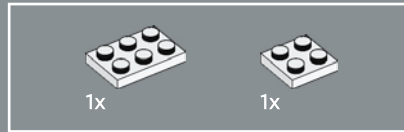
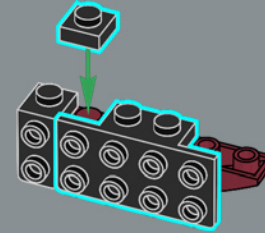

116

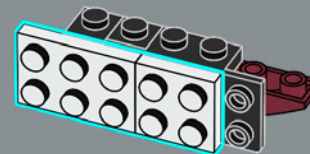

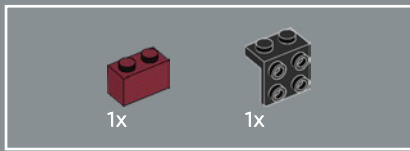

117

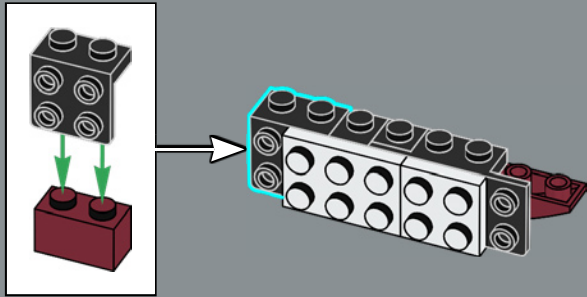

118

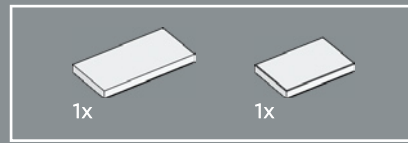
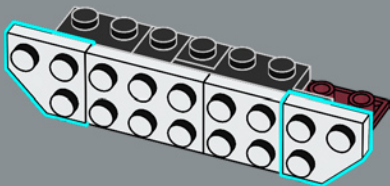

119

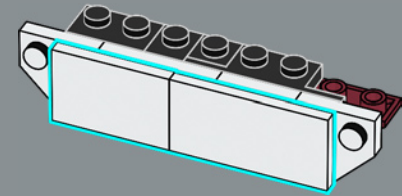

120

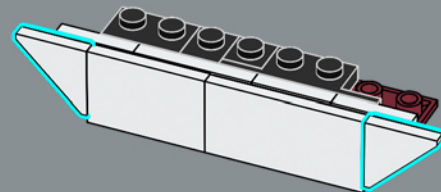

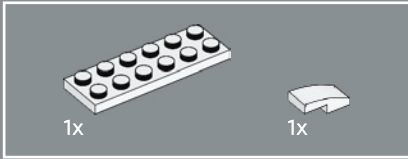
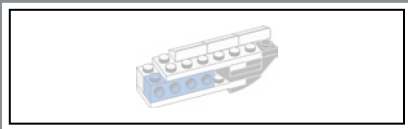

121

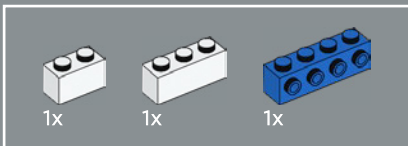
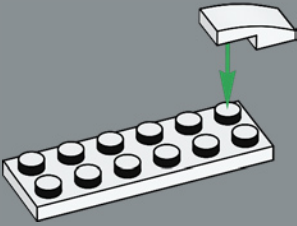

122

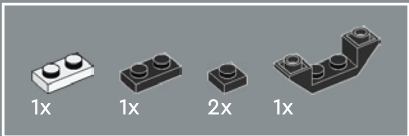
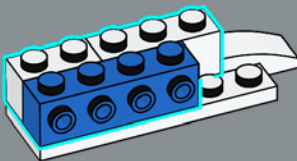

123

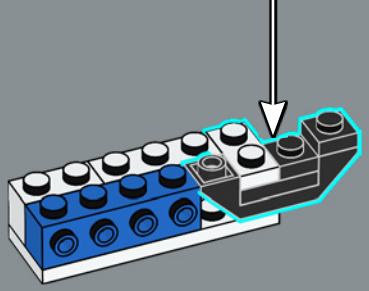
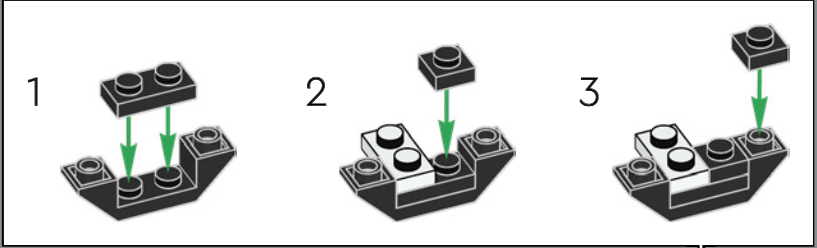

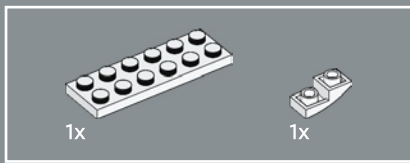

124

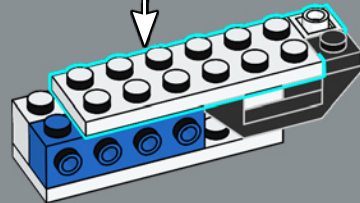
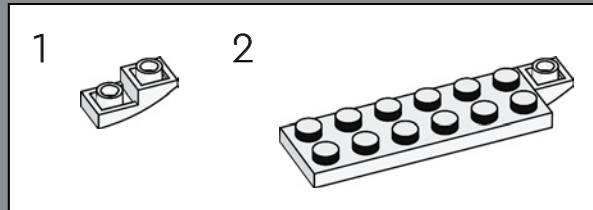

125

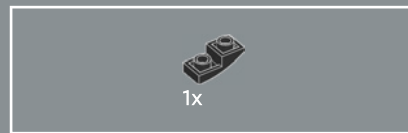
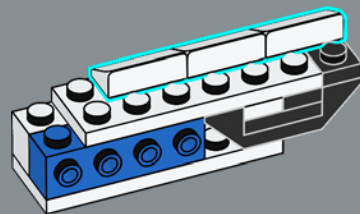

126

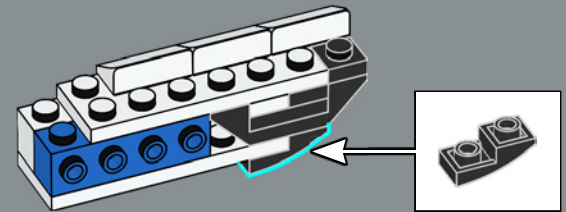

127

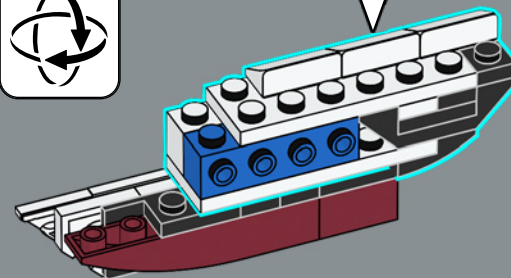



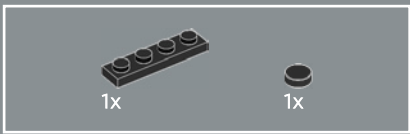

128

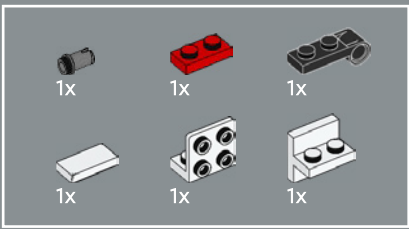
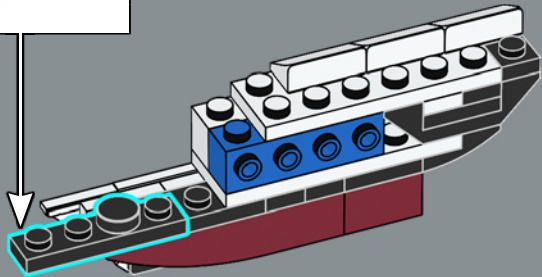
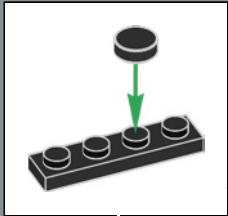

129

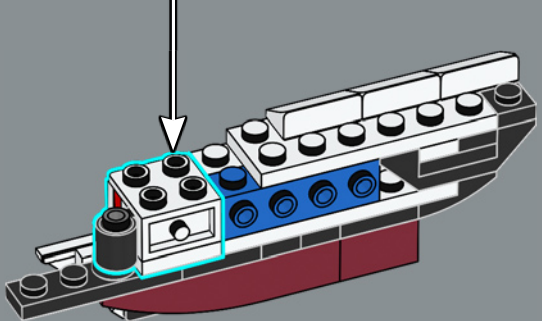
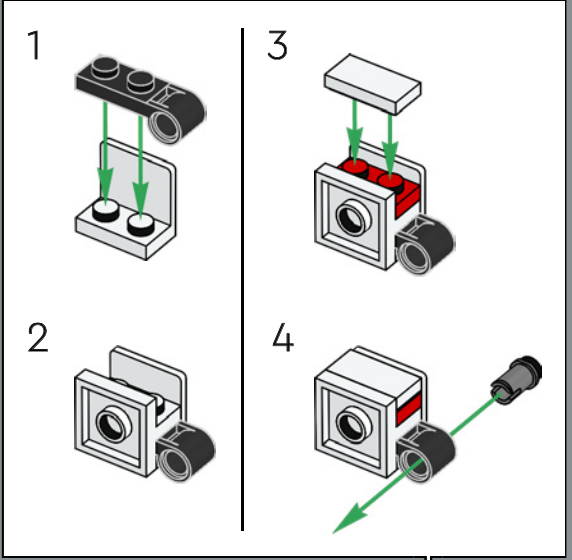

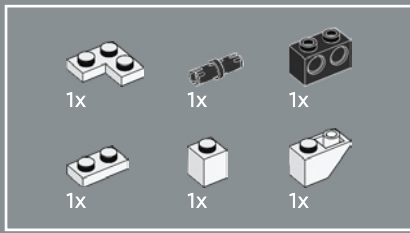

130

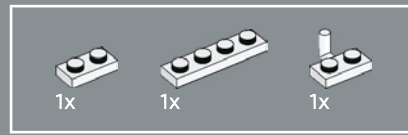
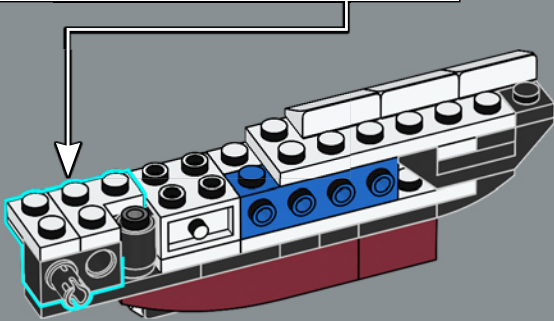
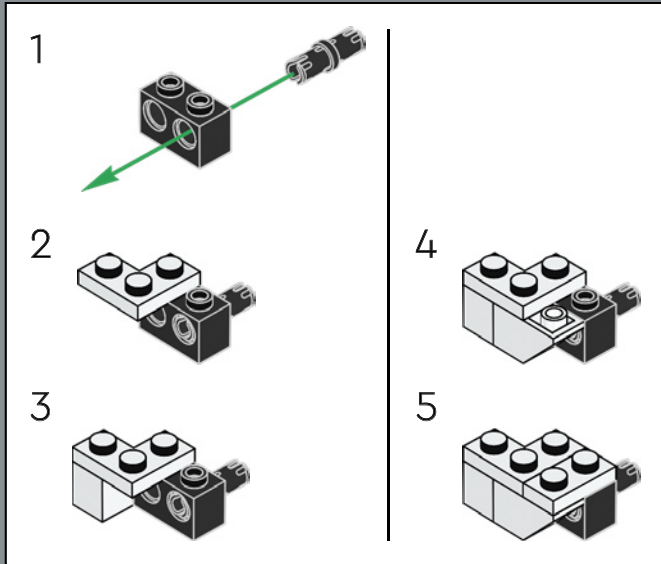

131

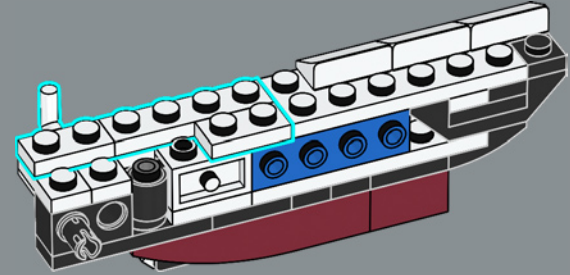

132

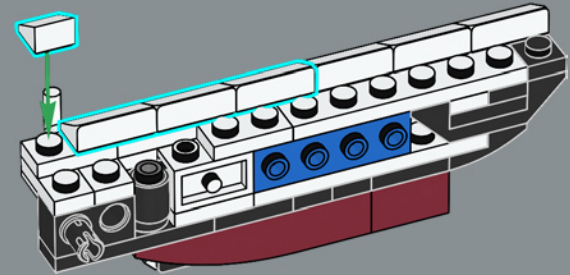



133

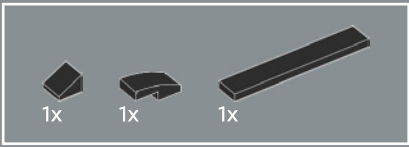
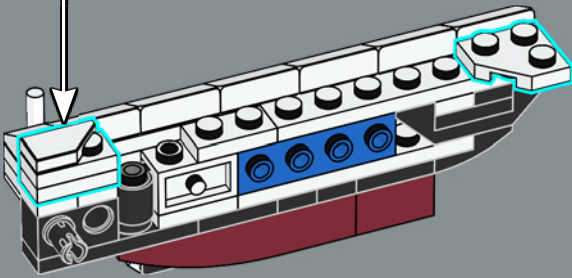
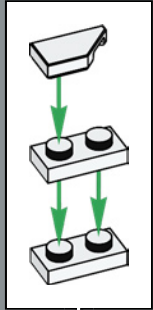

134

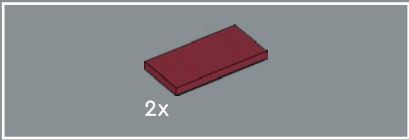
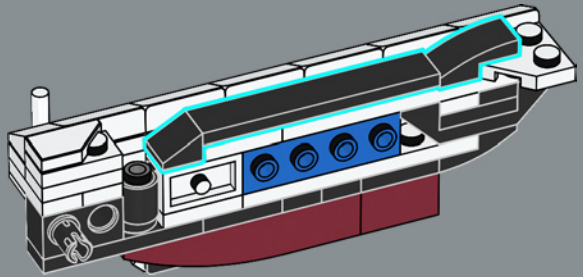

135

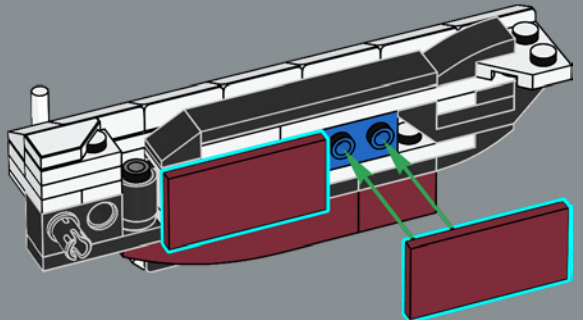

136

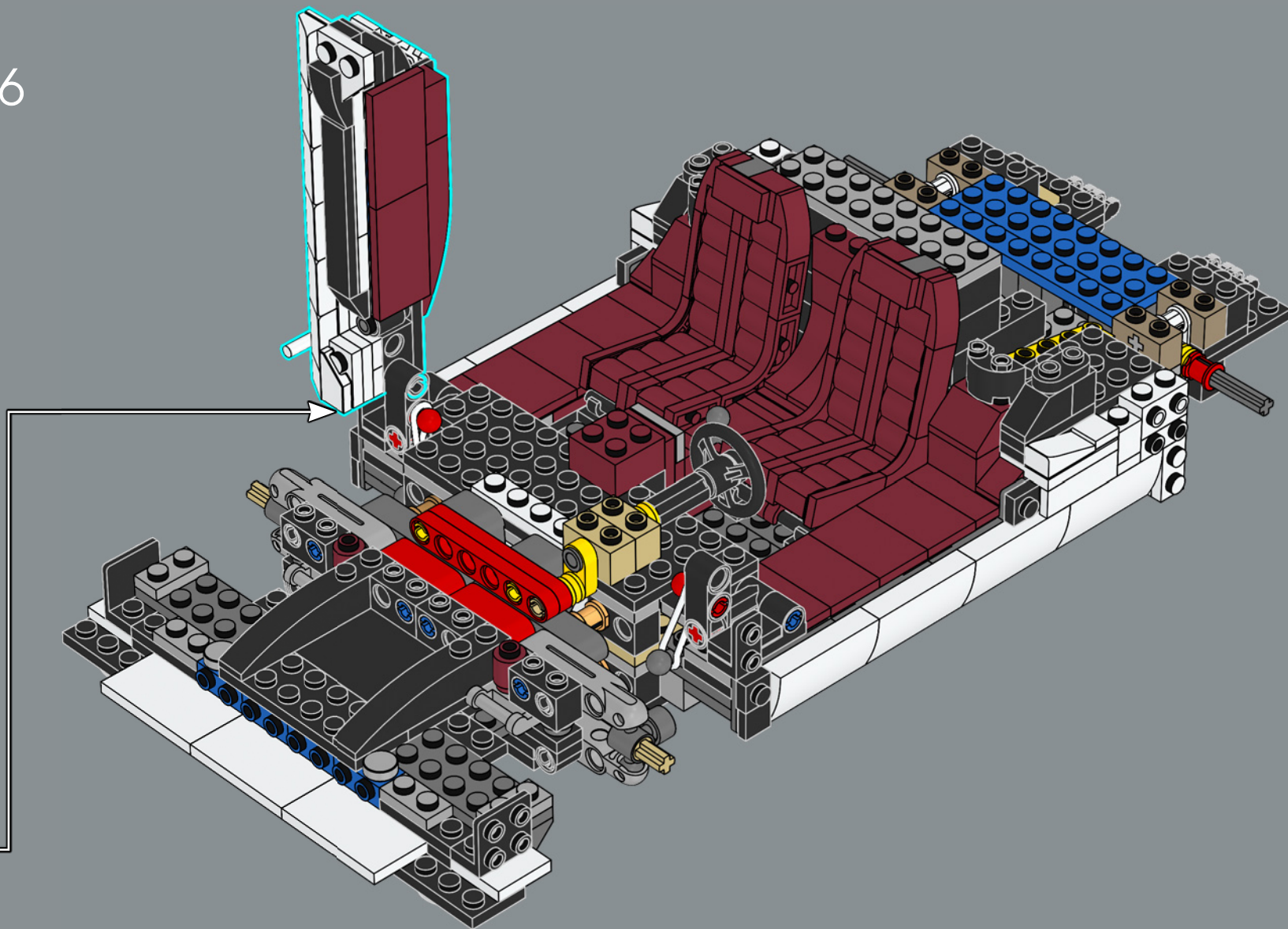



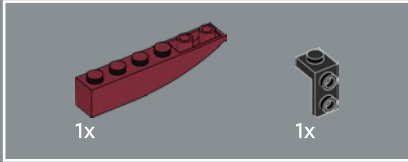
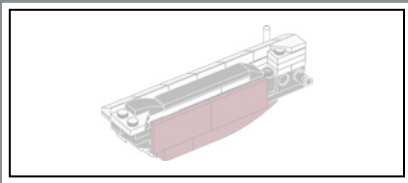

137

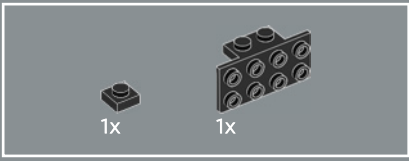
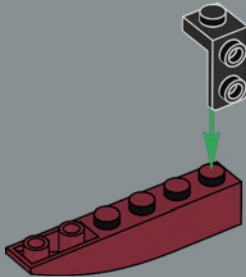

138

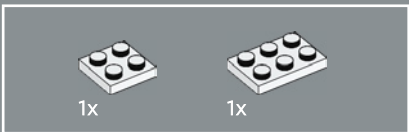
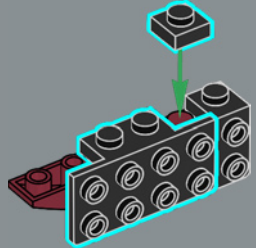

139

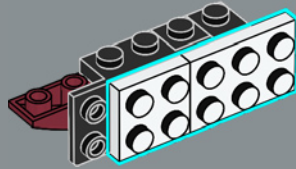

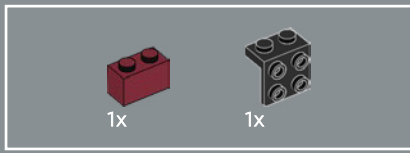

140

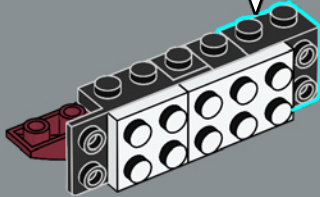
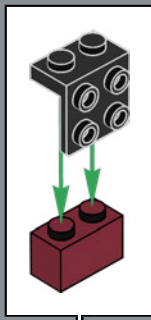

141

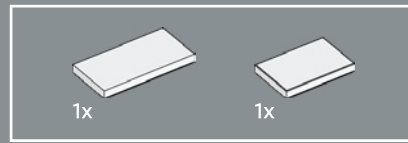
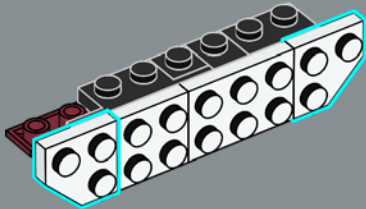

142

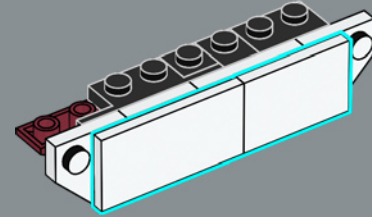

143

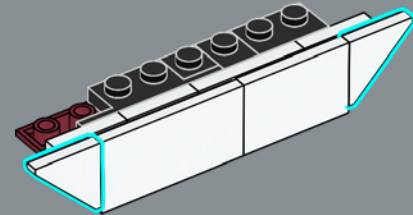

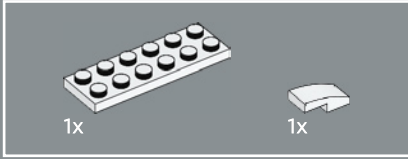
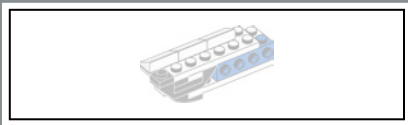

144

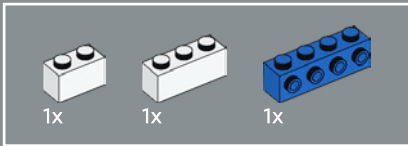
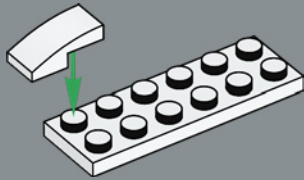

145

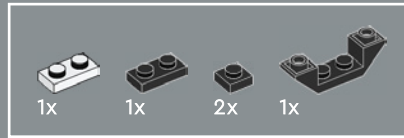
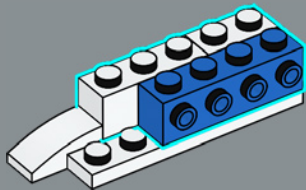

146

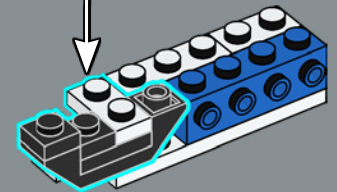
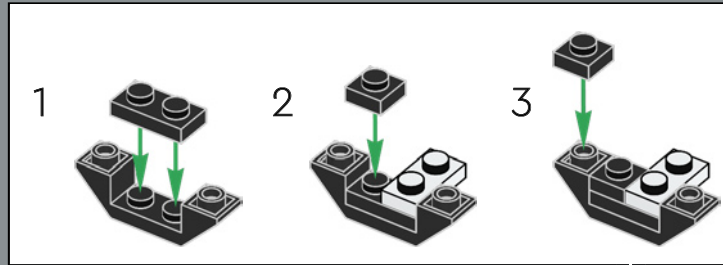

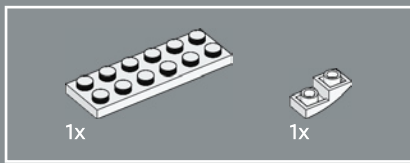

147

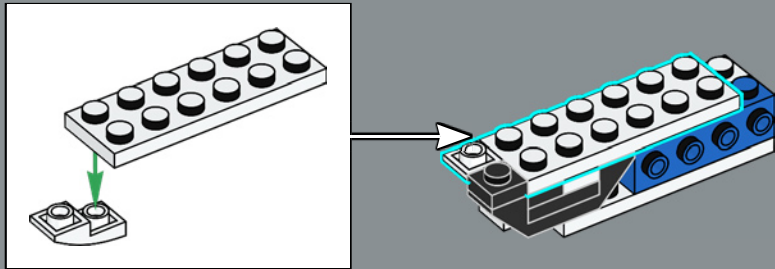

148

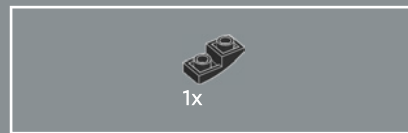
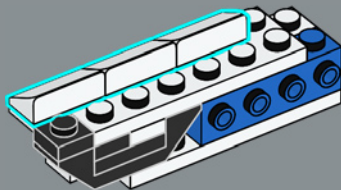

149

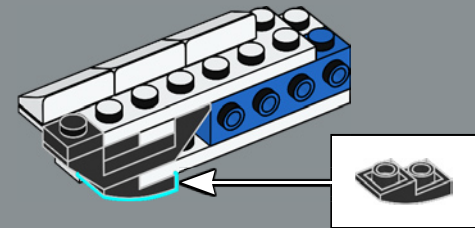

150

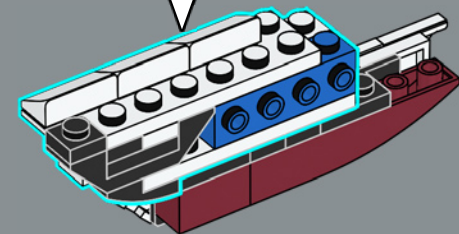



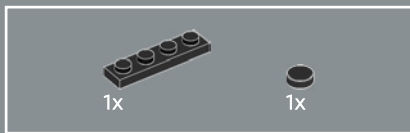

151

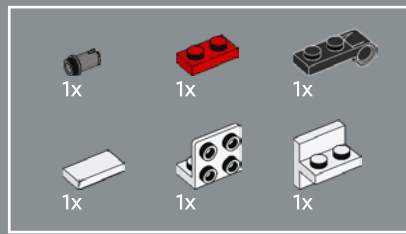
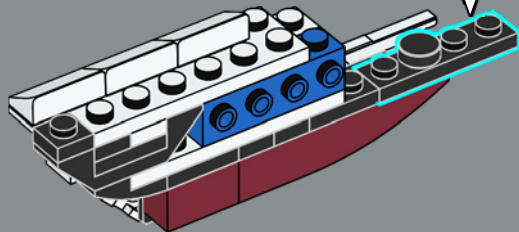
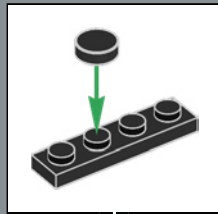

152

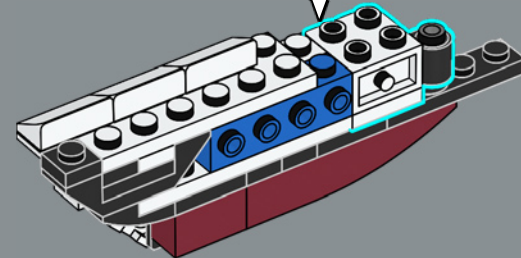
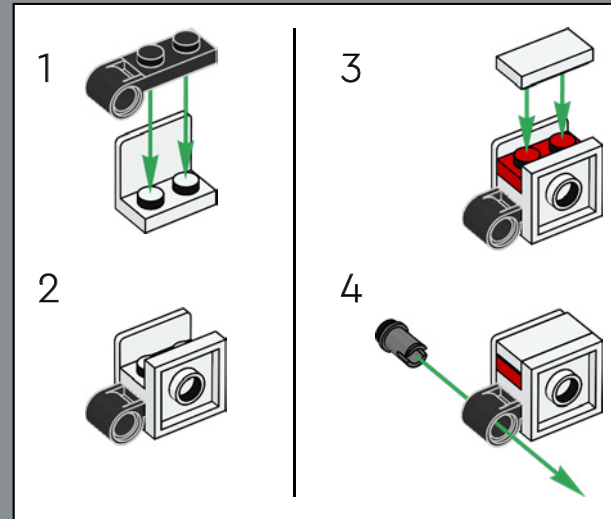

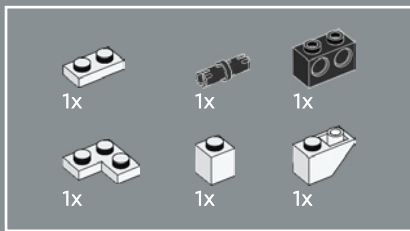

153

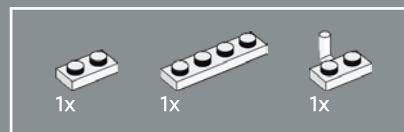
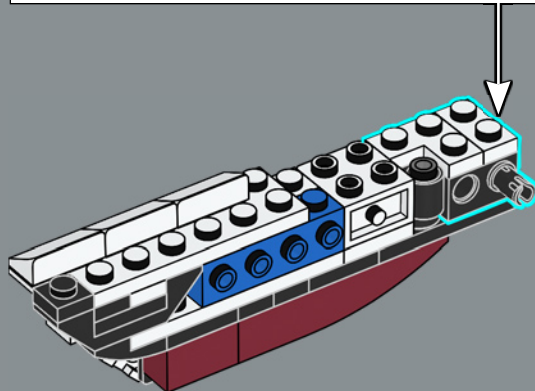
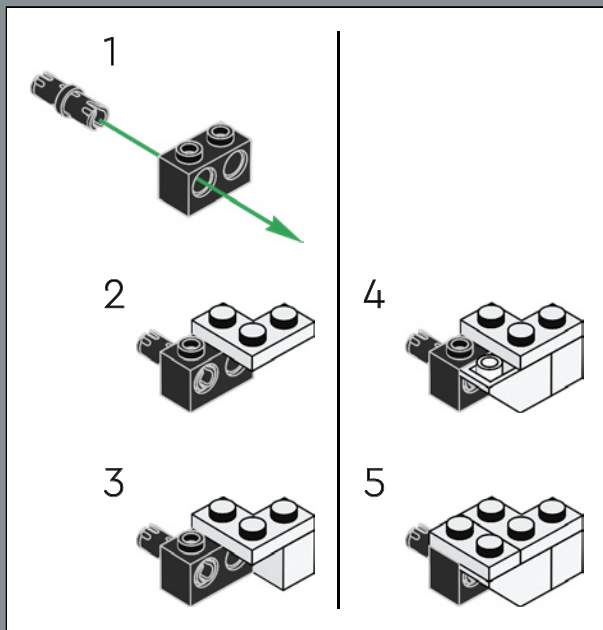

154

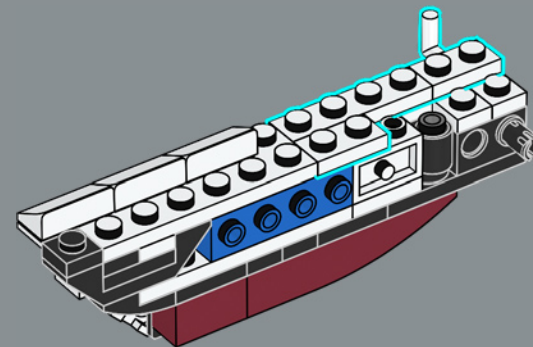



155

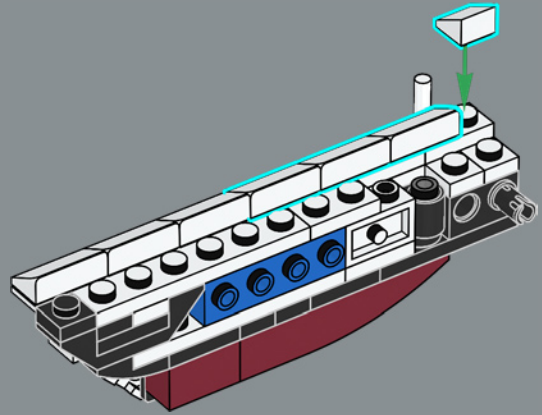

156

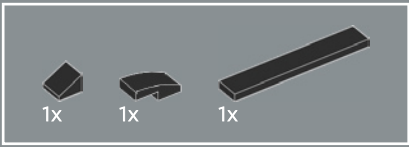
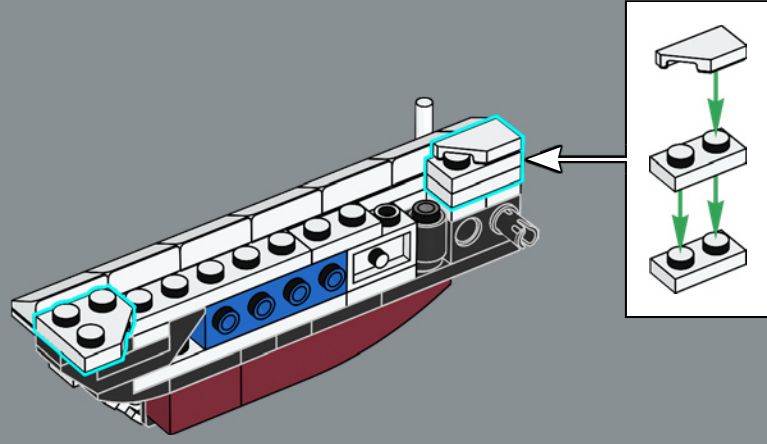

157

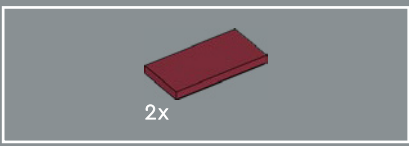
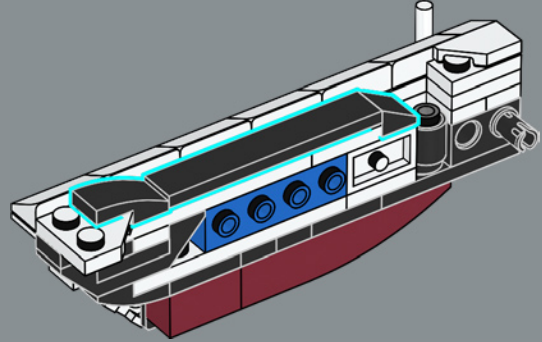

158

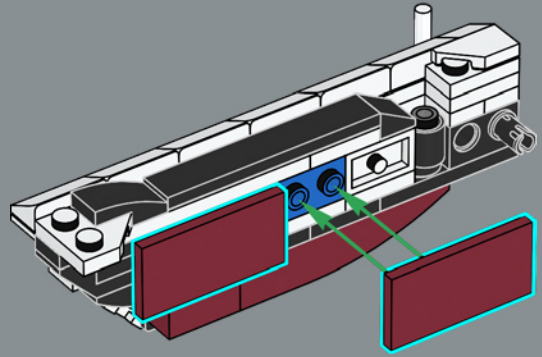



159

The upwards opening doors are commonly known as 'scissor doors.'

Les portes qui s'ouvrent vers le haut sont communément appelées « portes en ciseaux ».

Las puertas de apertura hacia arriba se conocen comúnmente como "puertas de tijera".

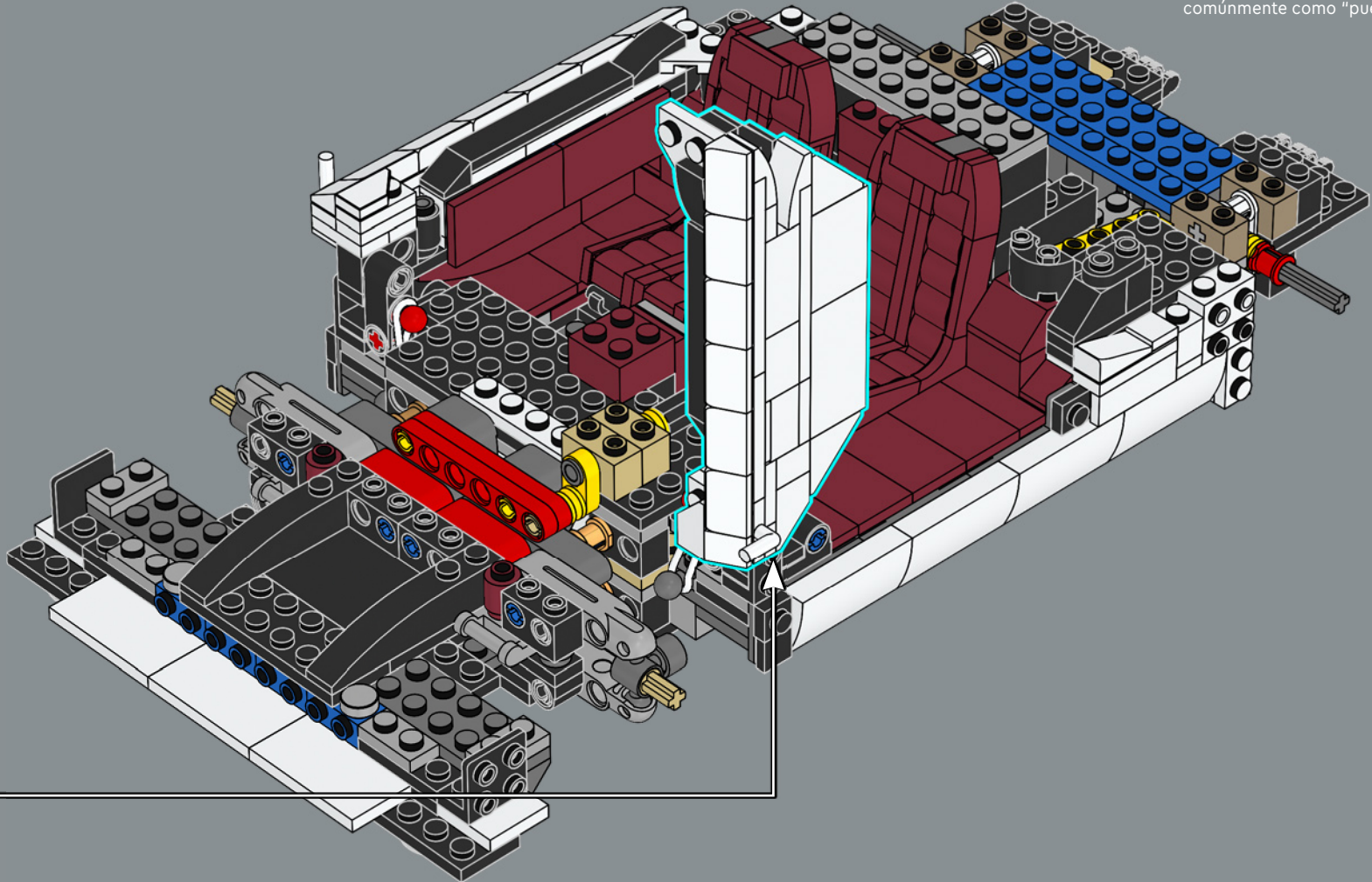



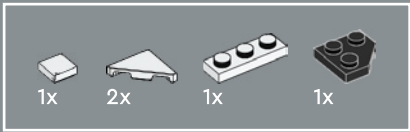

160

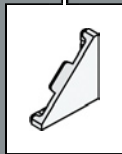
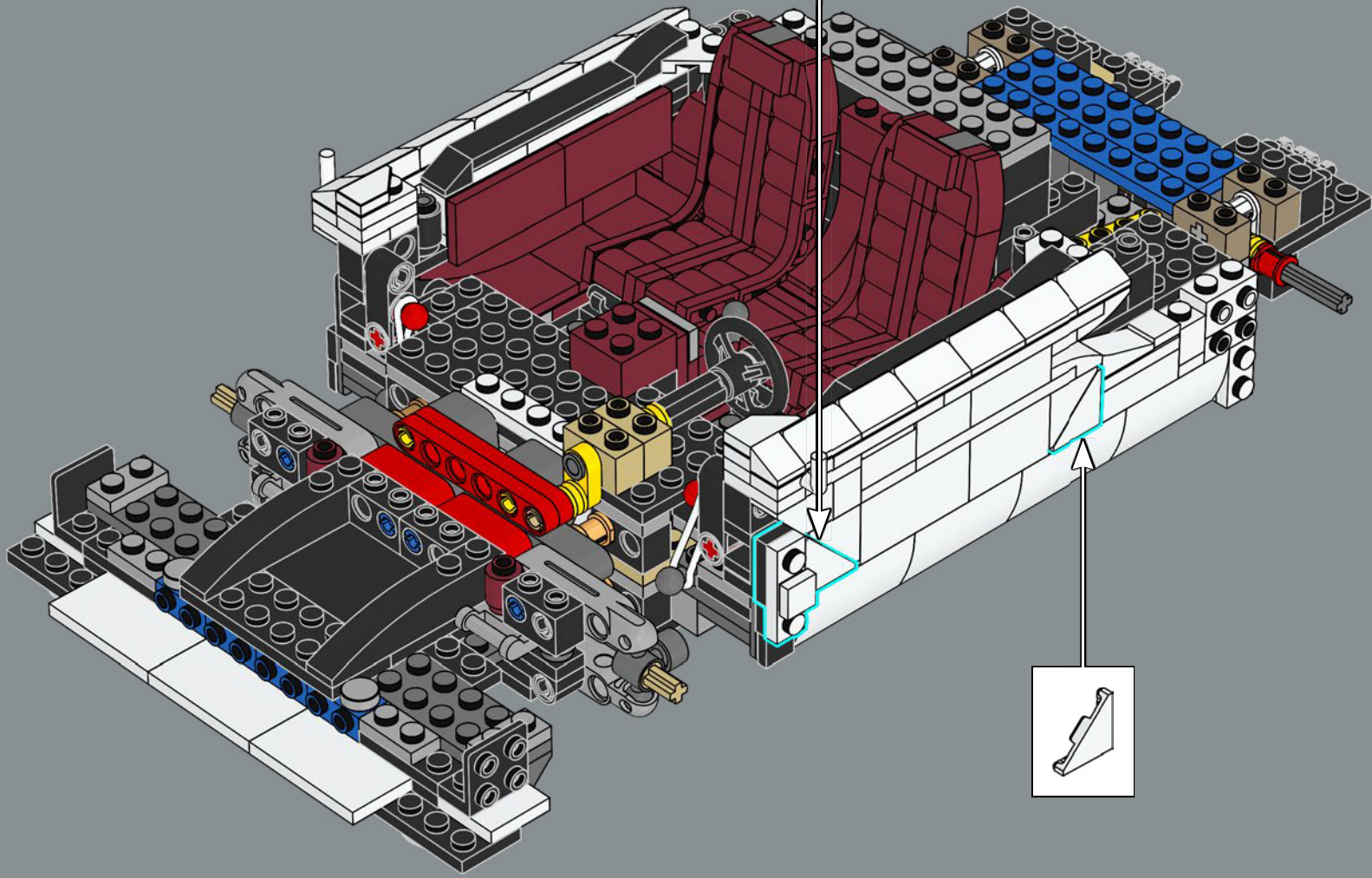
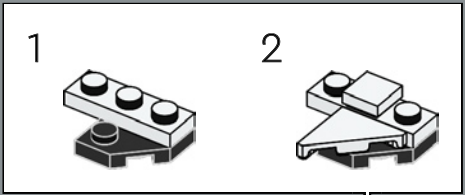

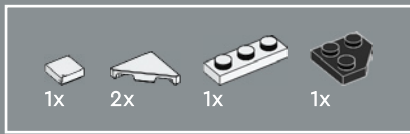

161

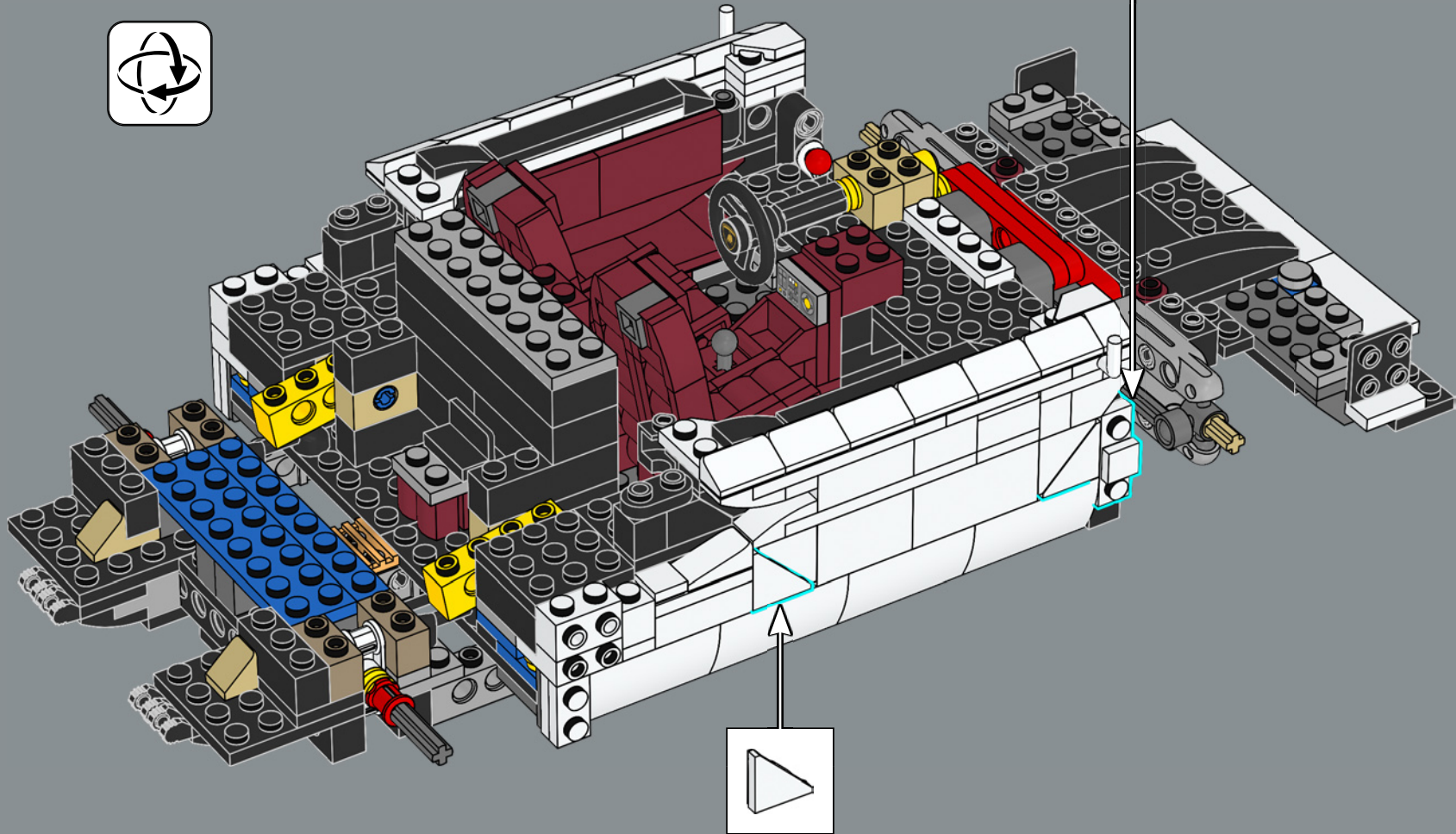
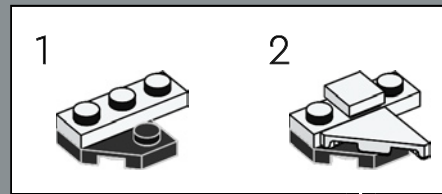

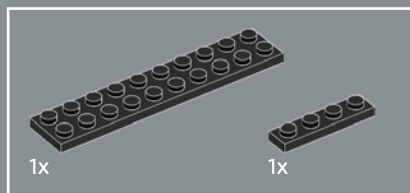
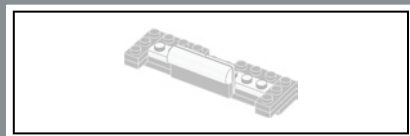

162

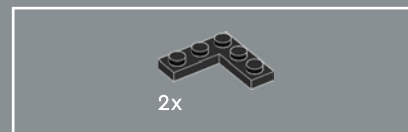
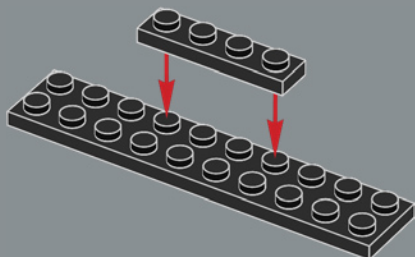

2x

163

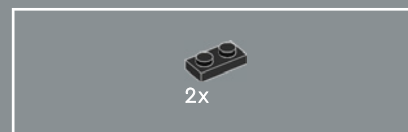
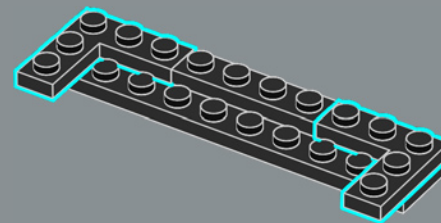

2x

164

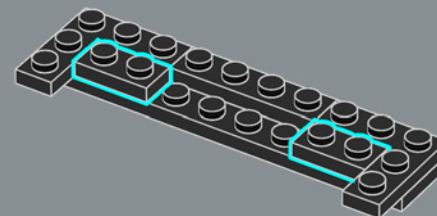



165

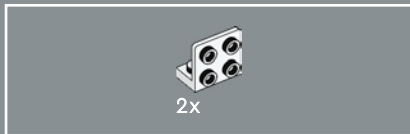
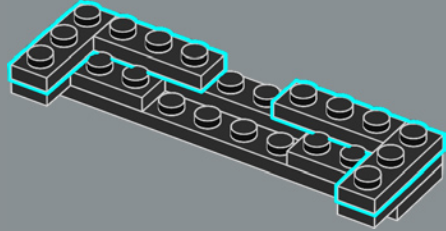

166

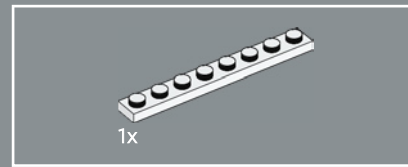
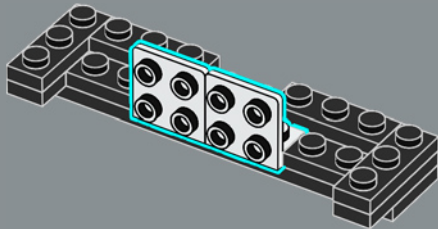

167

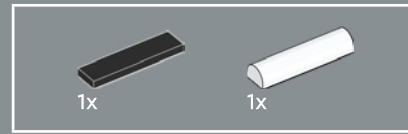
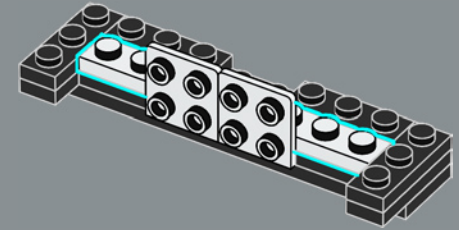

168

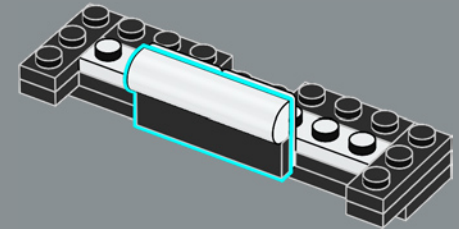



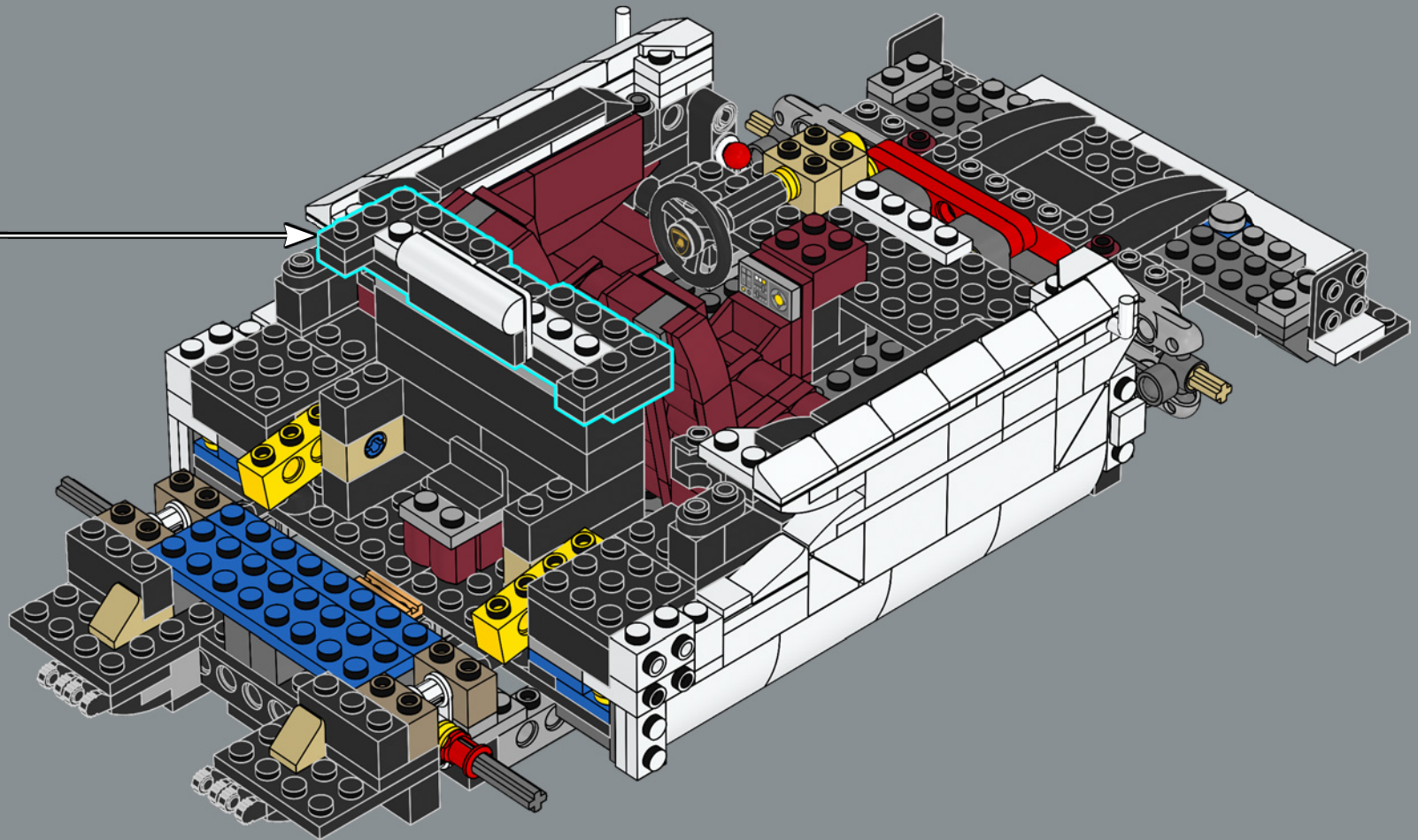

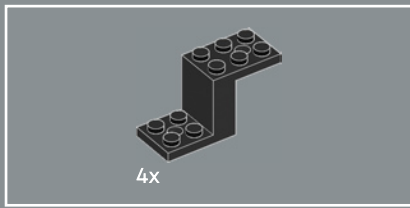

170

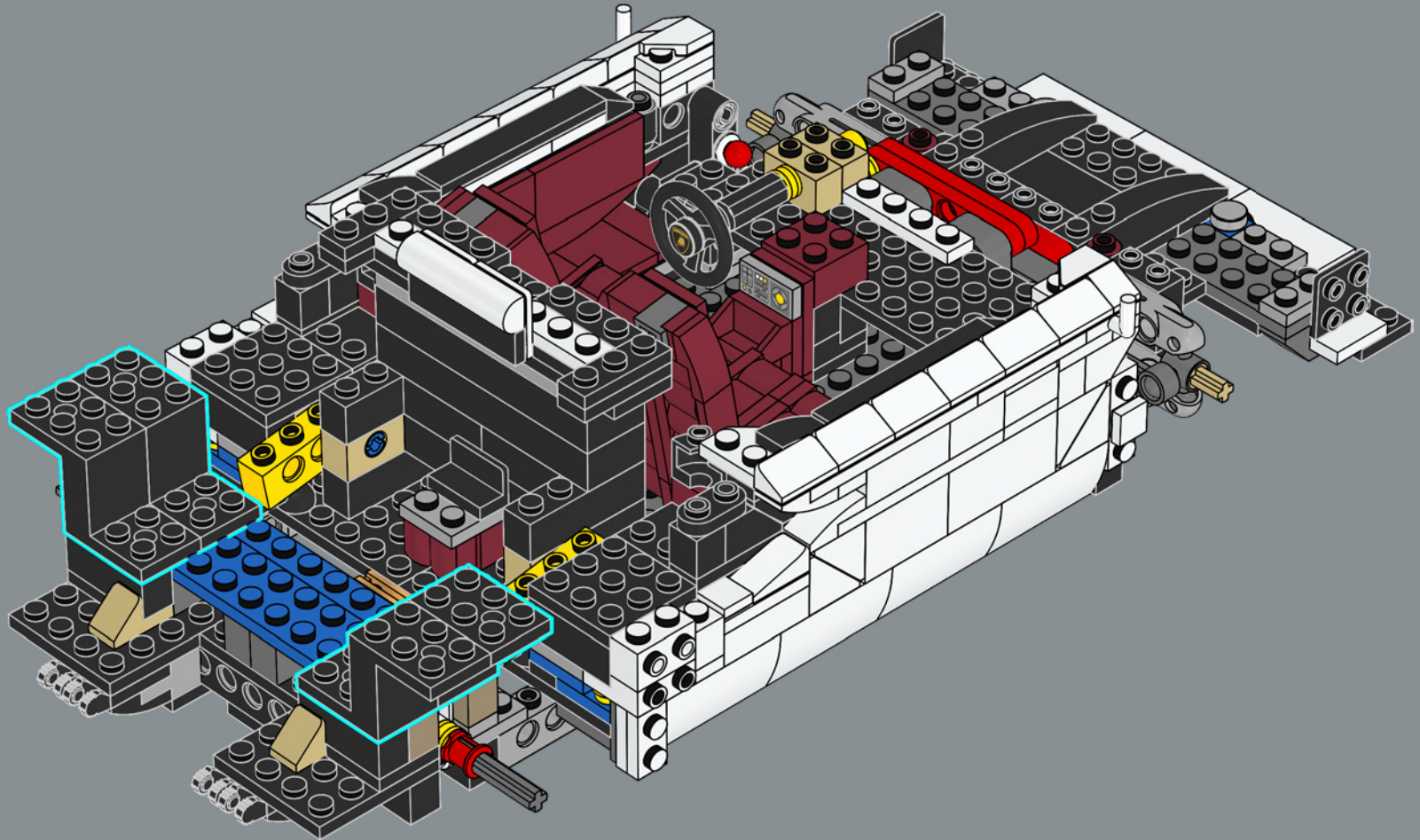



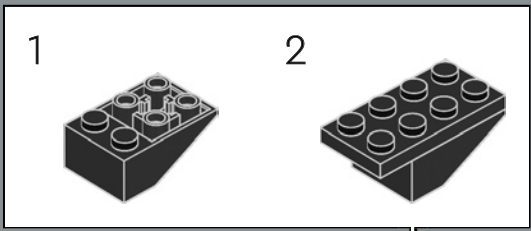
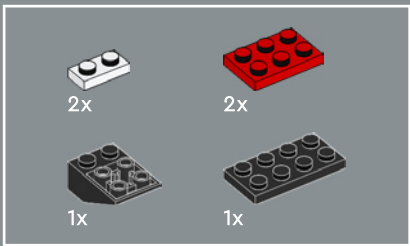

171

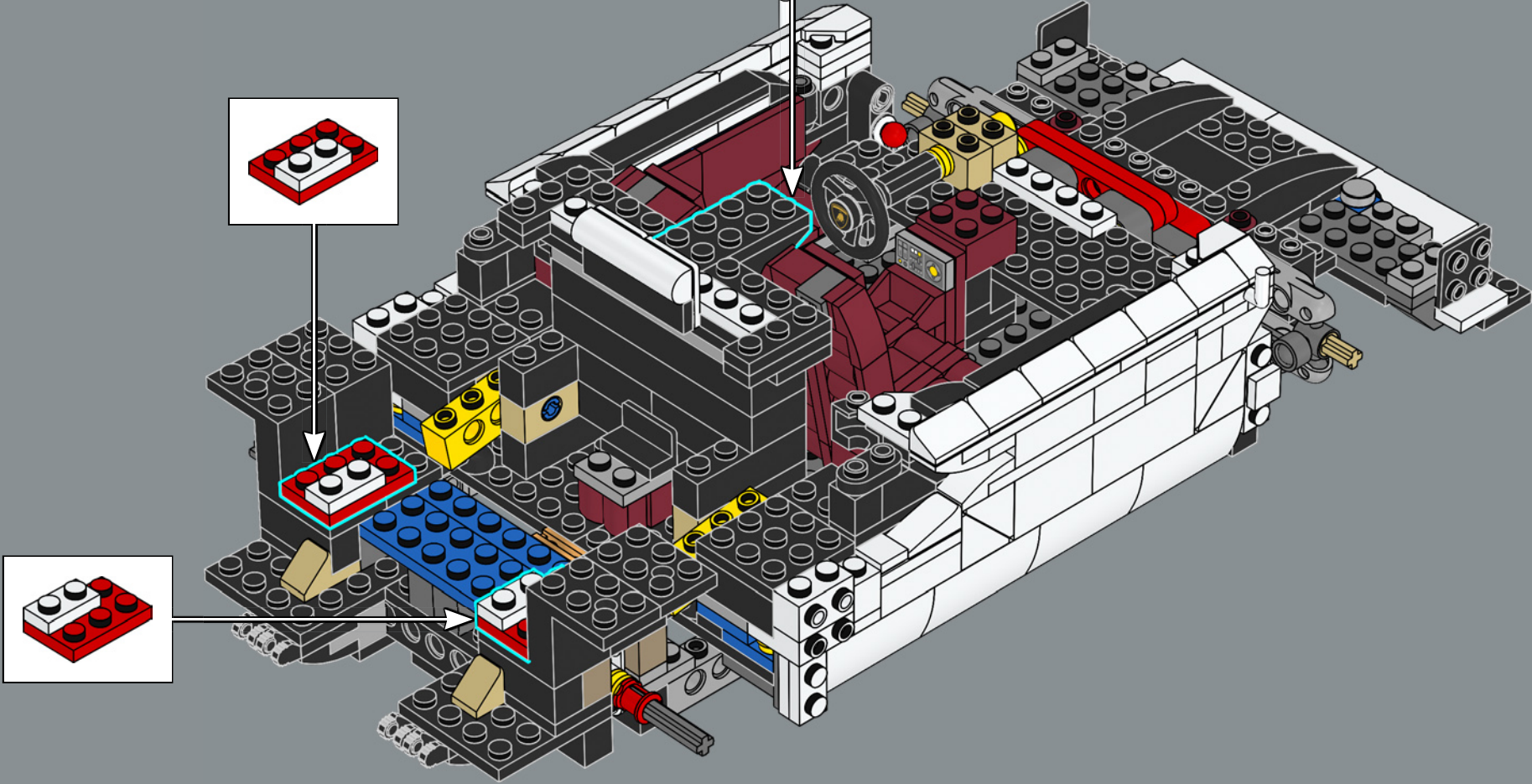

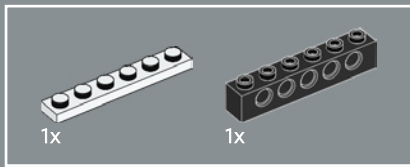

172

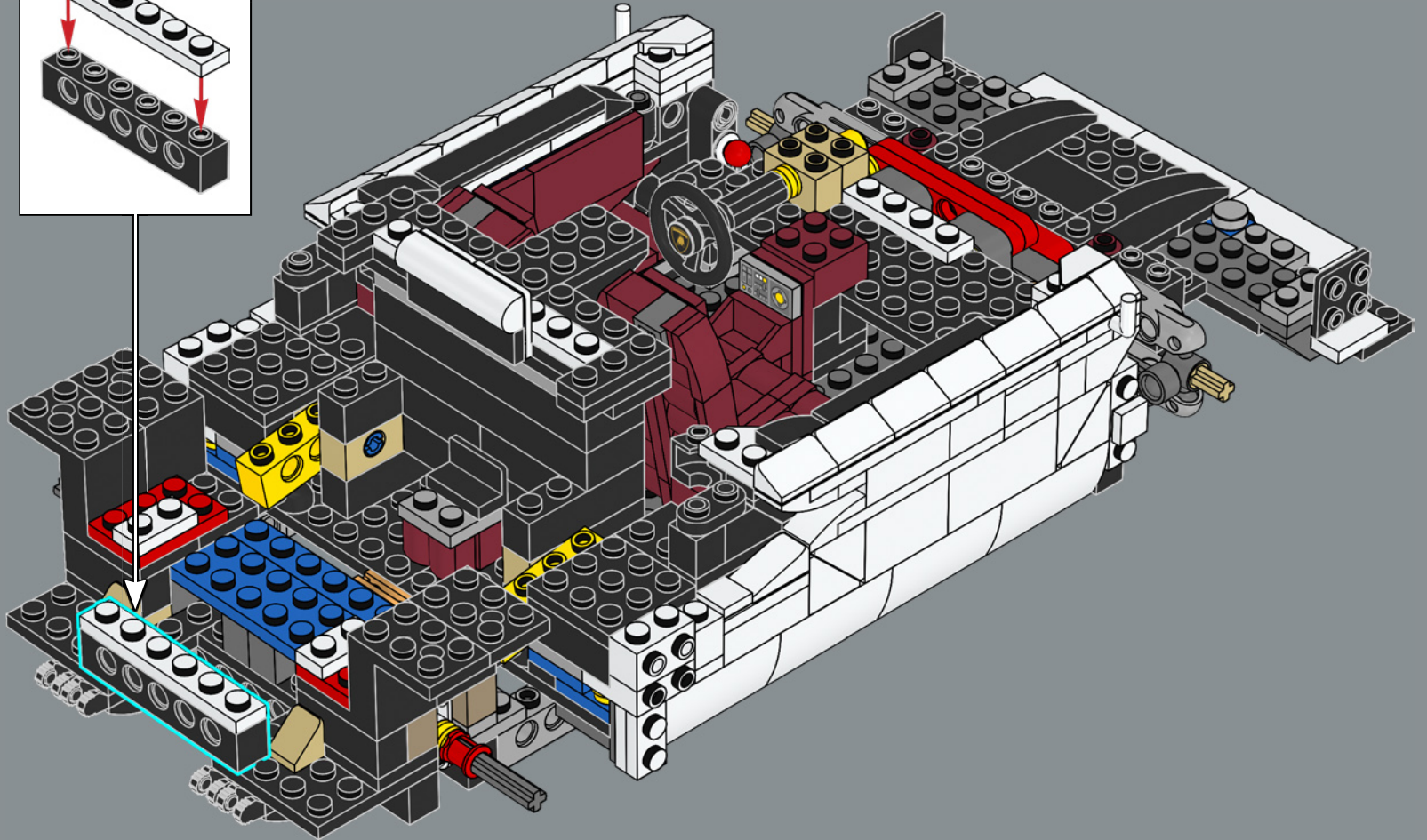
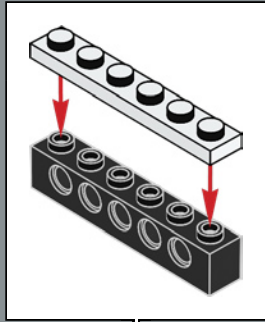



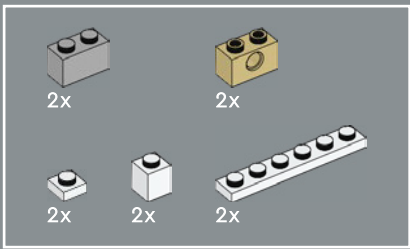

173

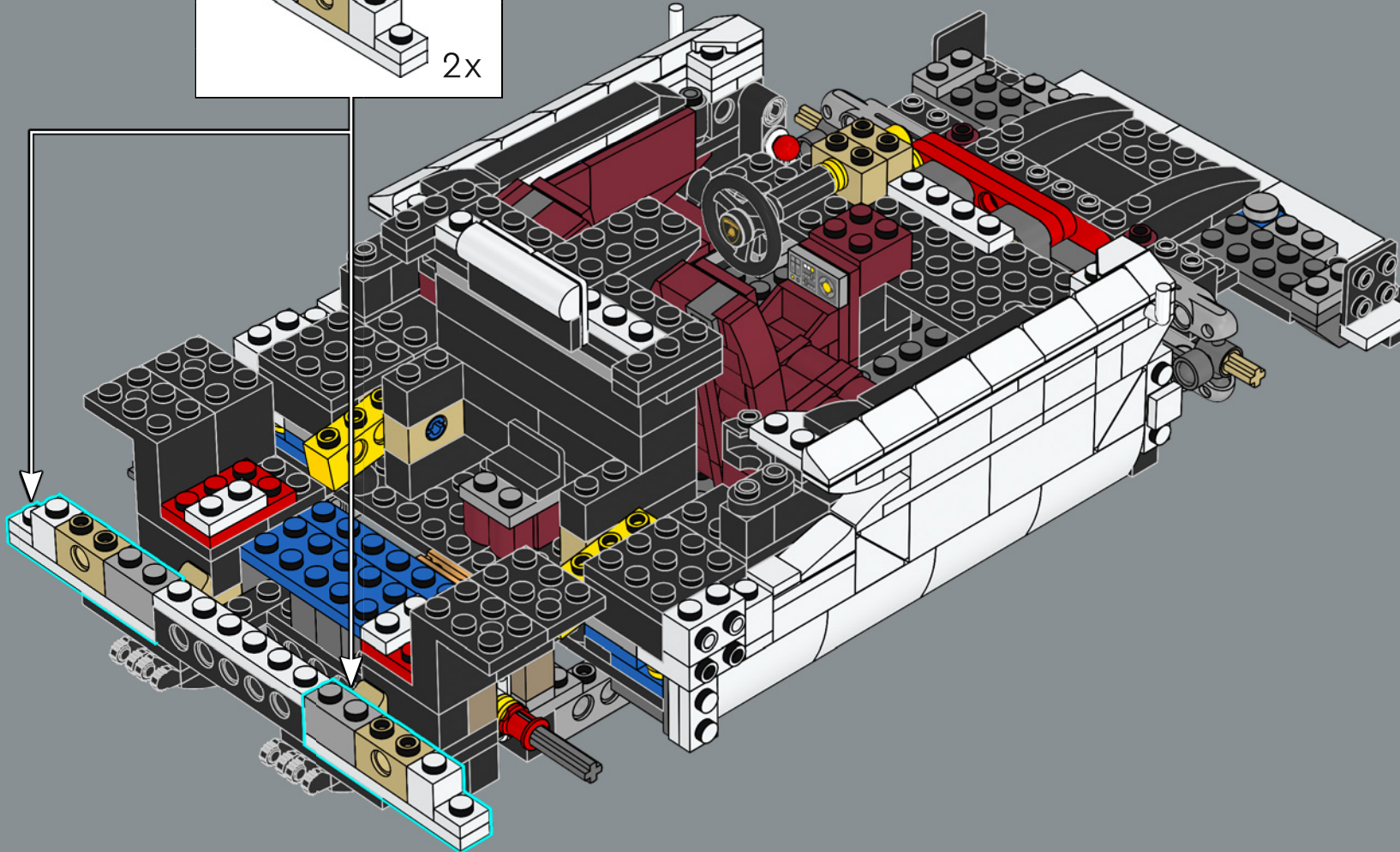
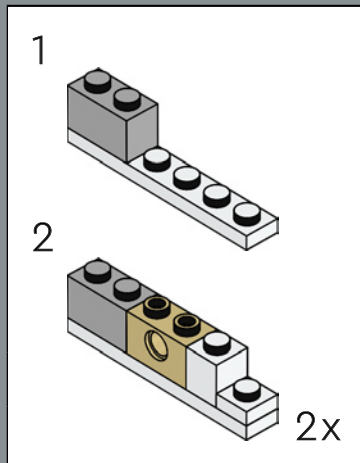

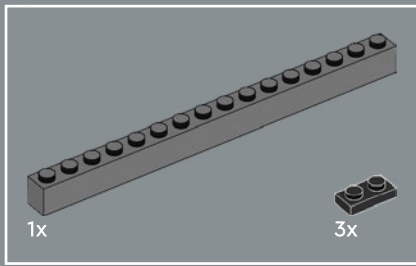

174

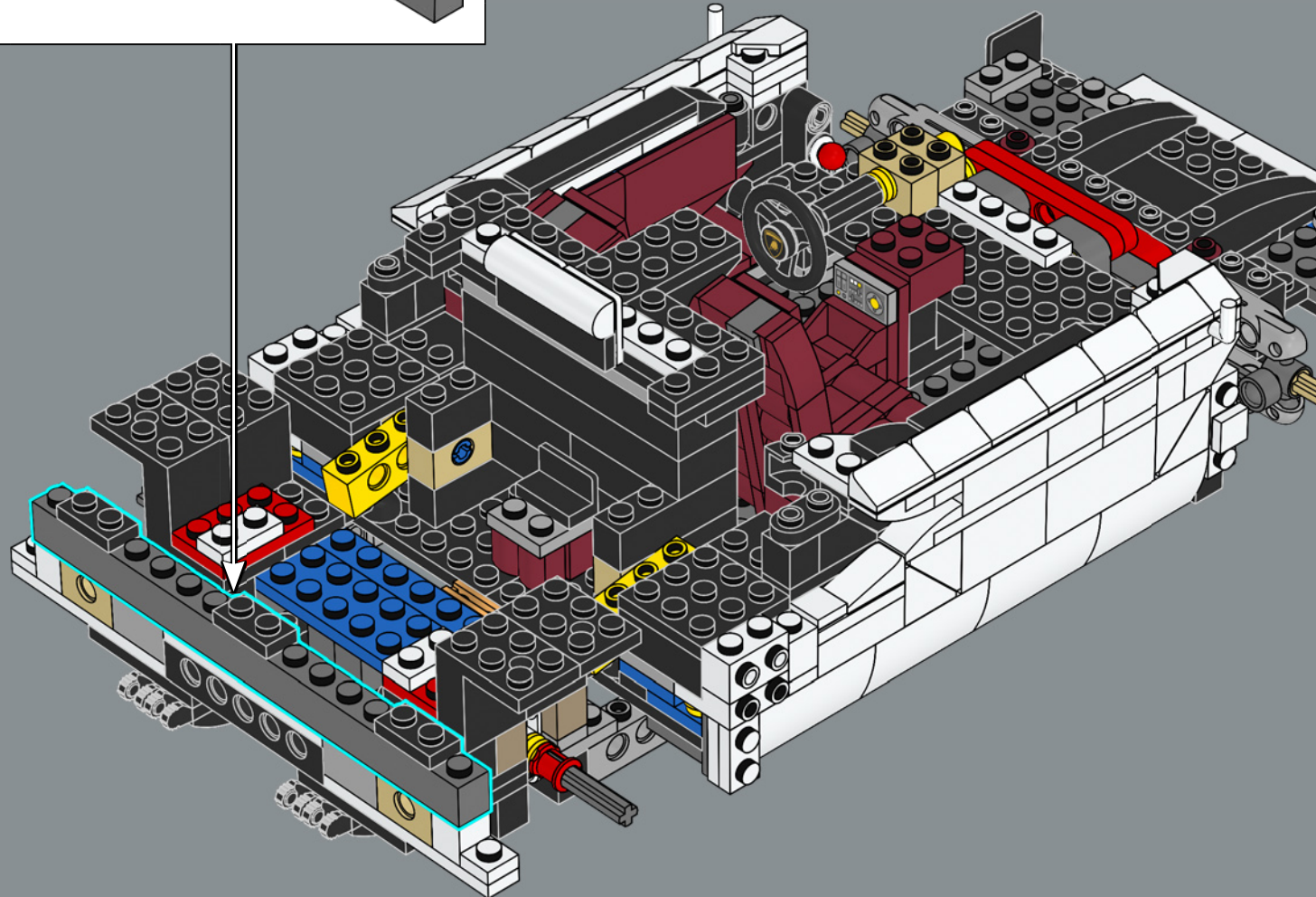
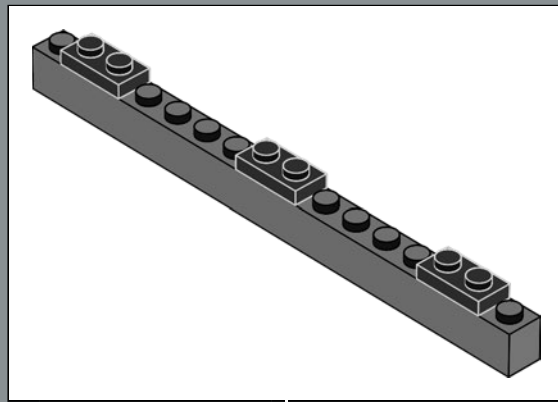



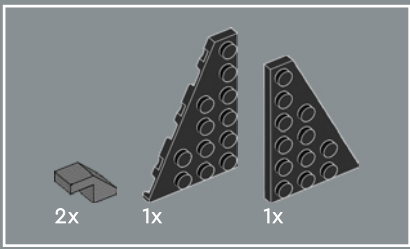

175

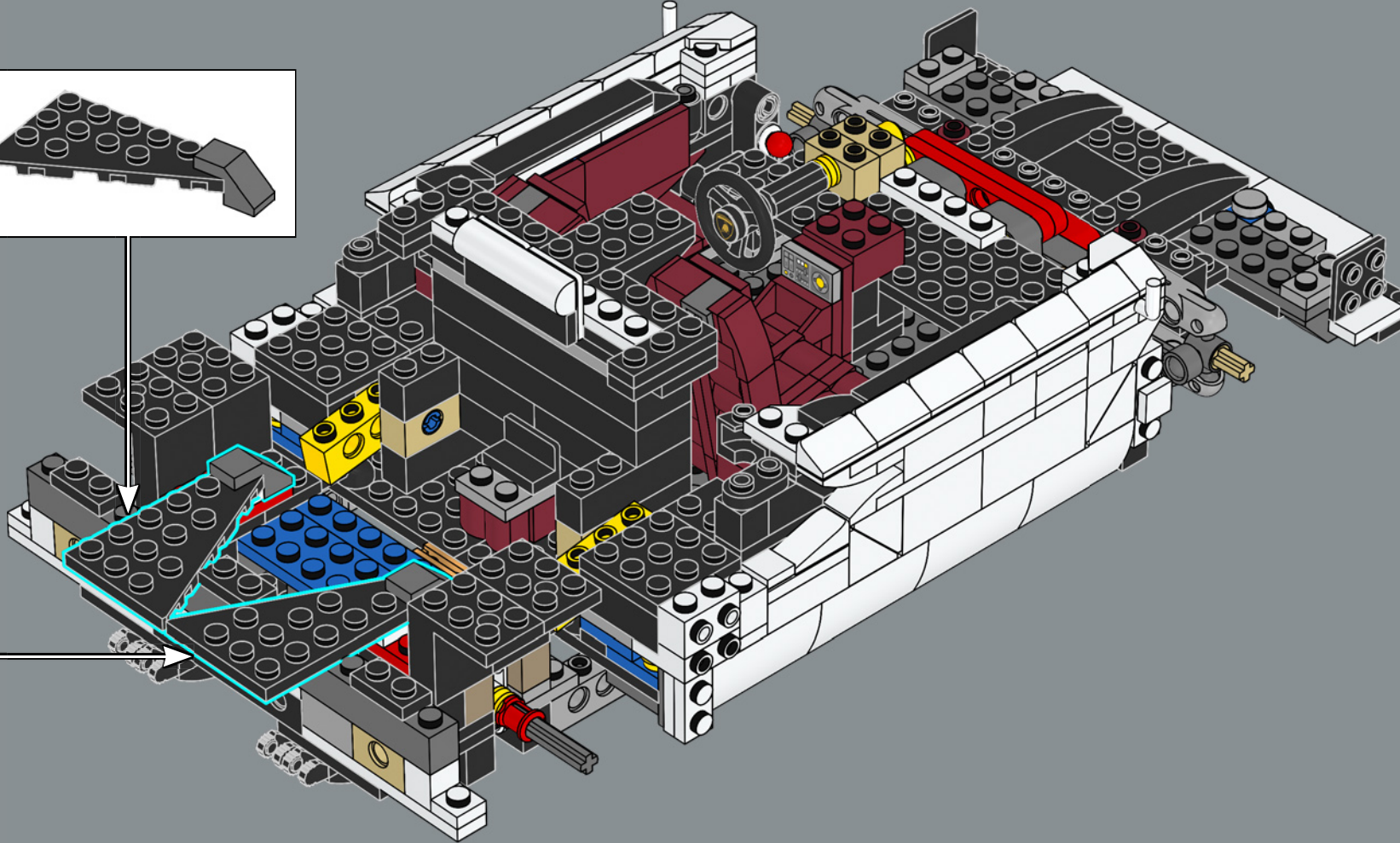
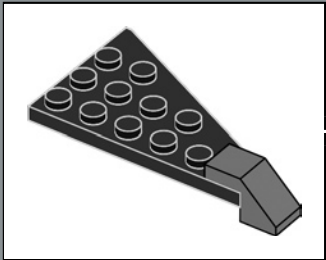
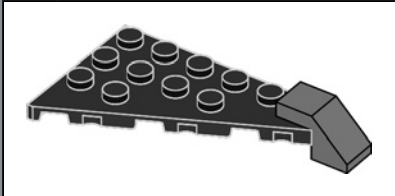

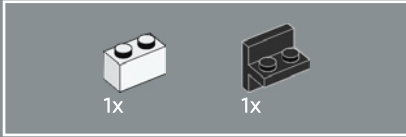
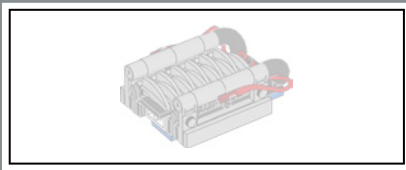

176

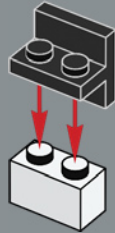

177

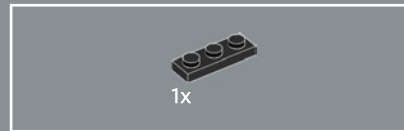
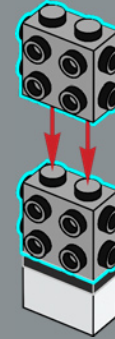

178





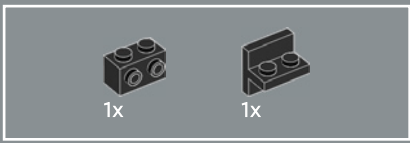

179

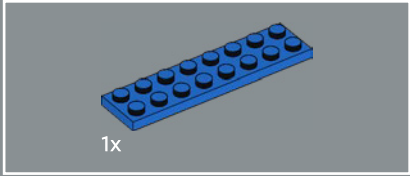
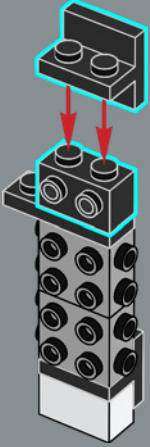

180

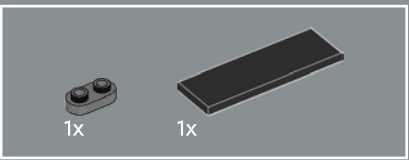
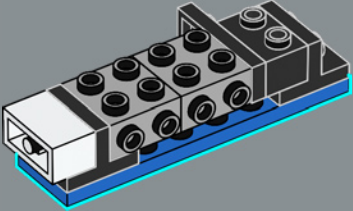

181

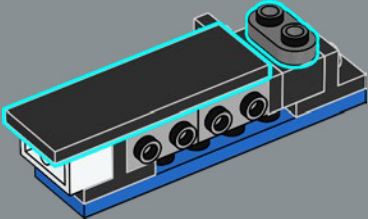

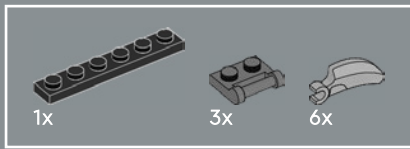

182

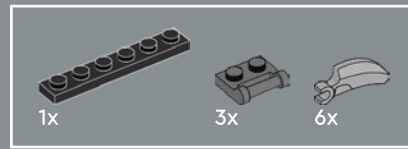
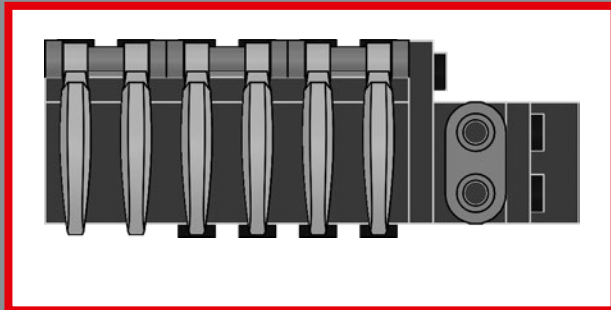
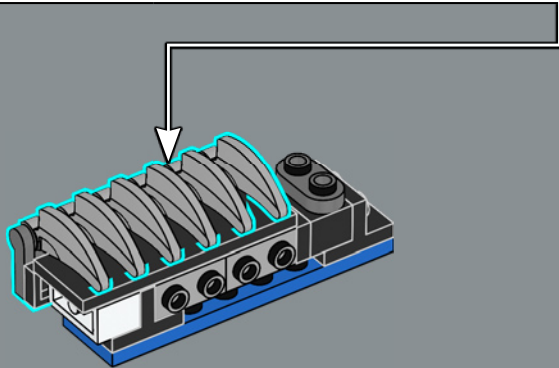
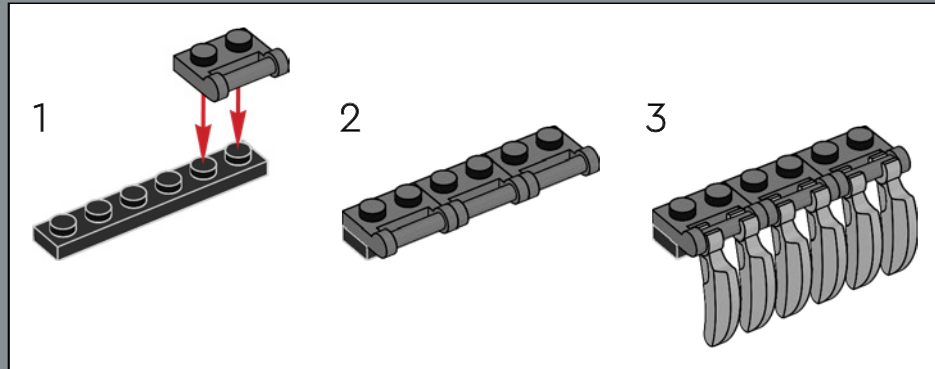

183

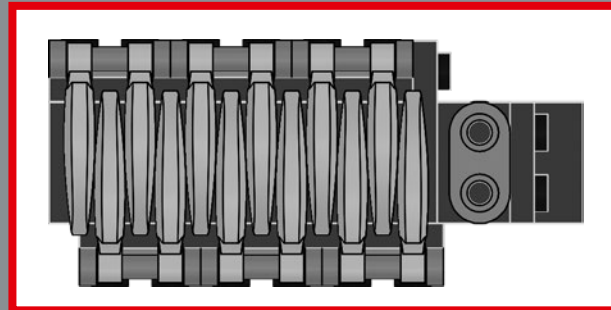
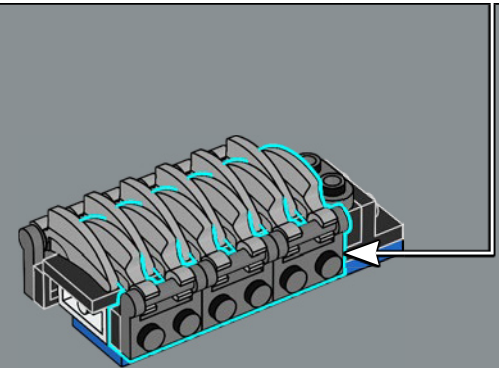
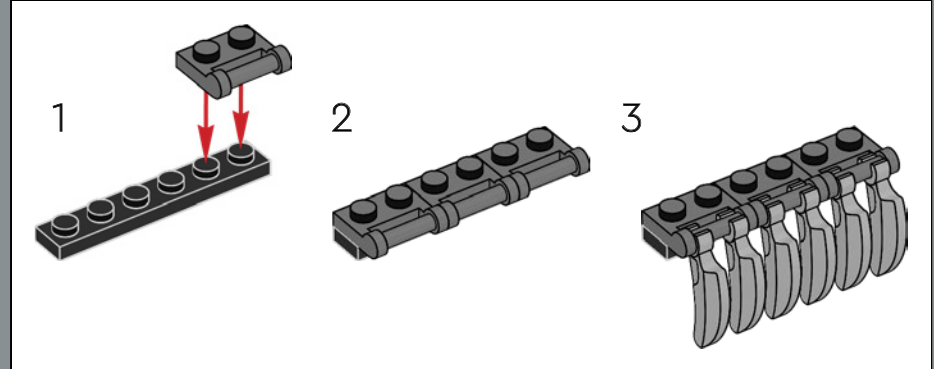

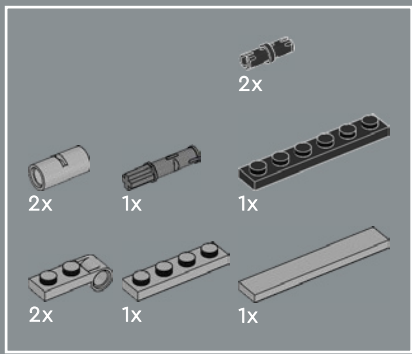

184

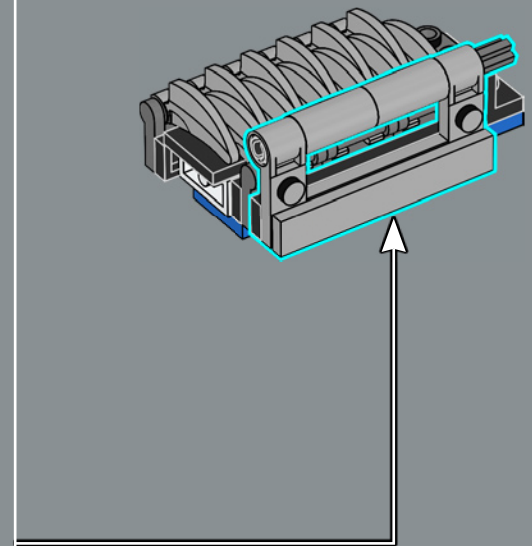
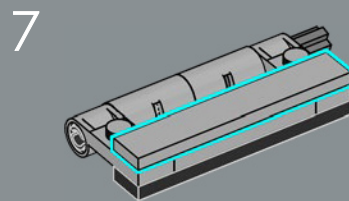
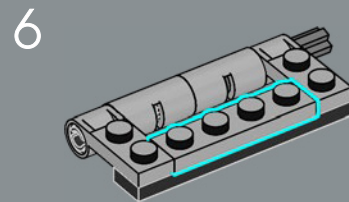
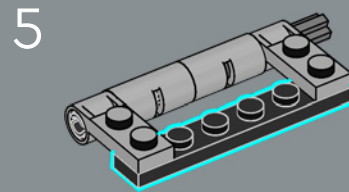
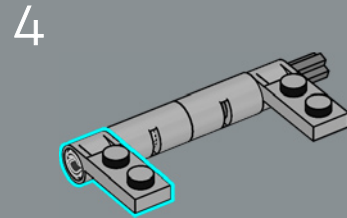
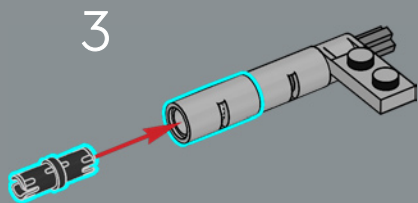
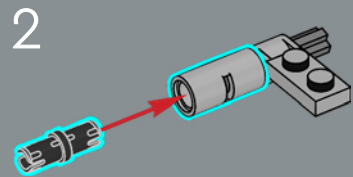
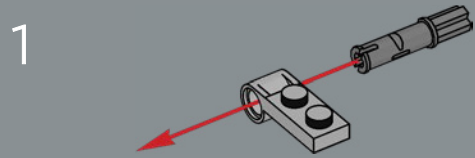

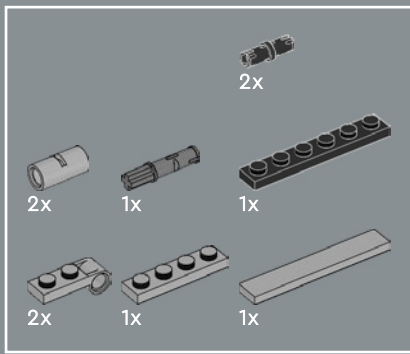

185

1

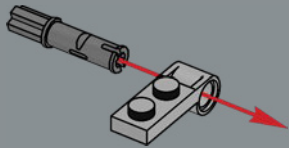

2

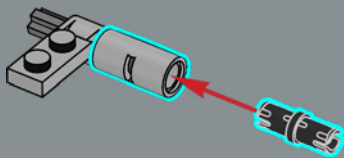

3

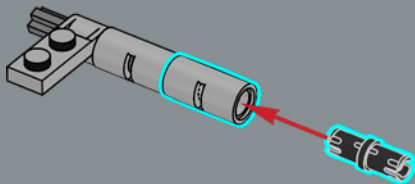

4

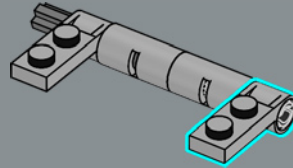

5

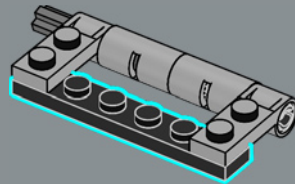

6

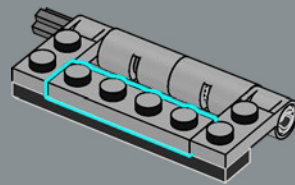

7

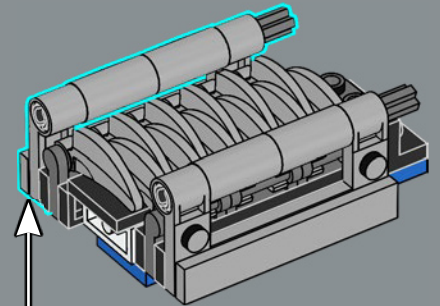
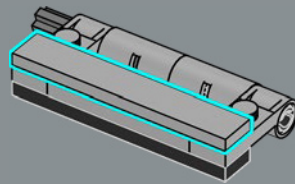



2x

186

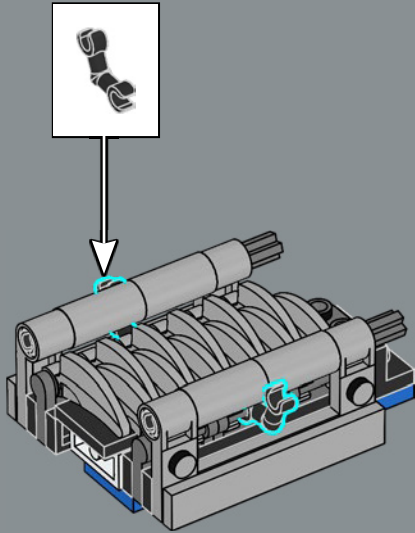

2x

187

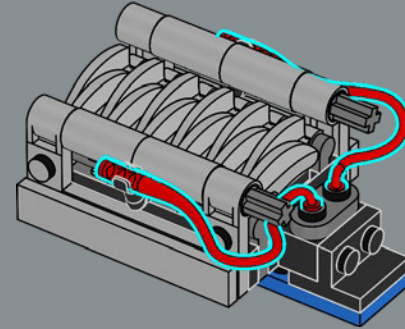

2x

188

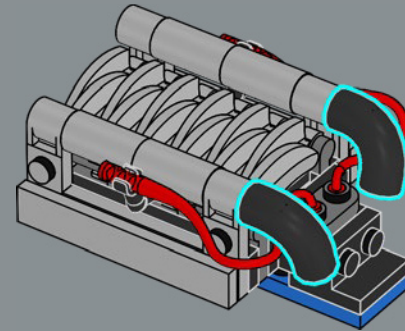



189

The LP in Countach names stands for Longitudinale Posteriore (rear longitudinal in English), as that is the position of the engine.

Les lettres « LP » dans les noms de Countach signifient « Longitudinale Posteriore » (longitudinal arrière en français), en référence à la position du moteur.

Las siglas LP en los nombres de los Countach hacen referencia a *longitudinale posteriore* (*longitudinal posterior* en español), ya que esa es la posición del motor.

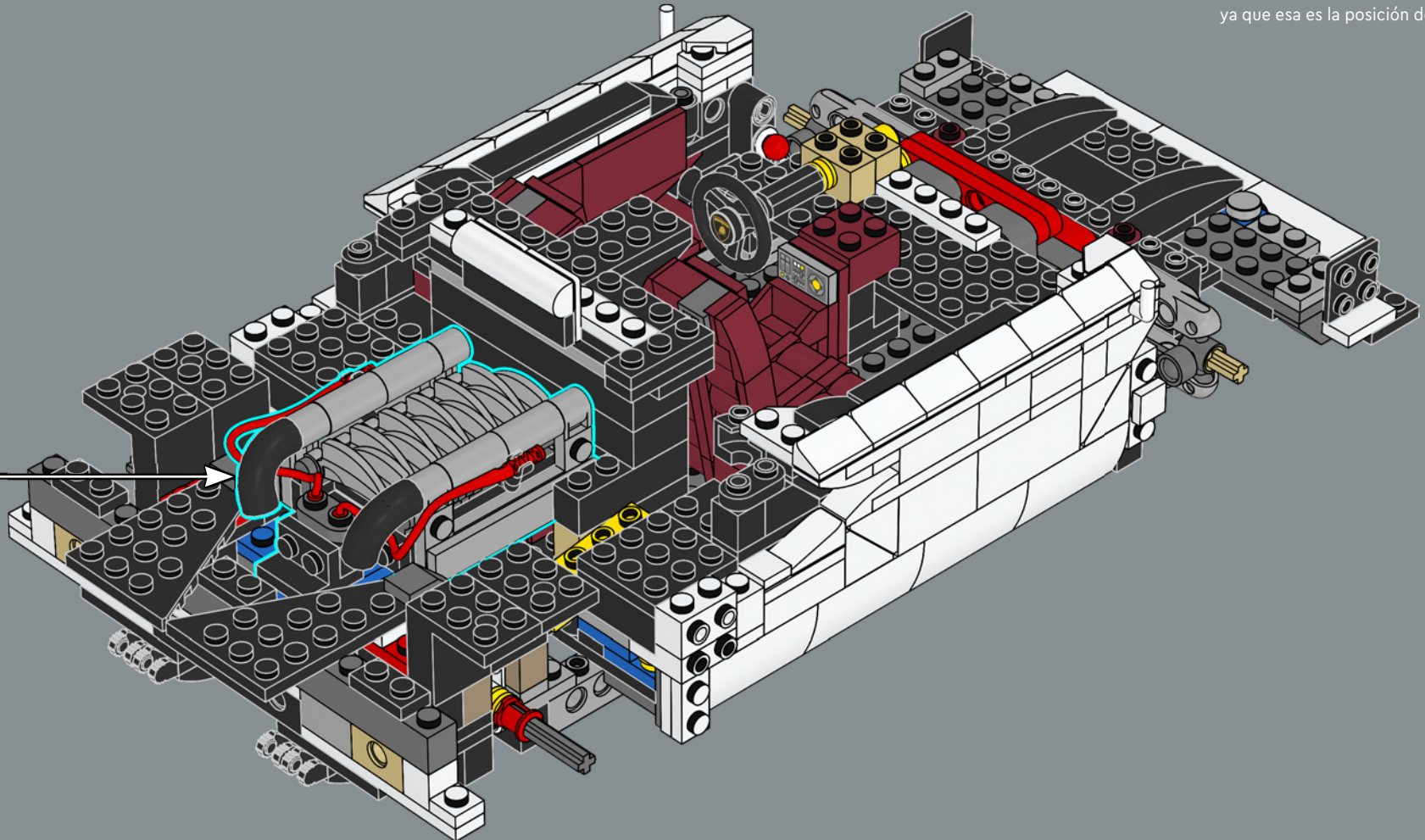

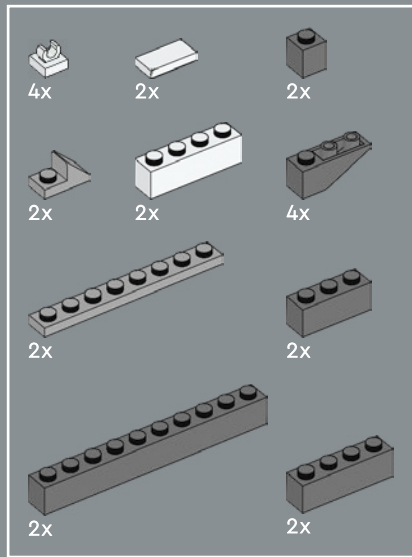
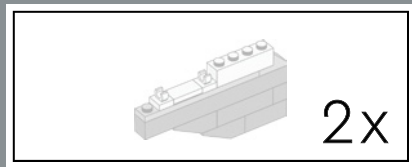

190

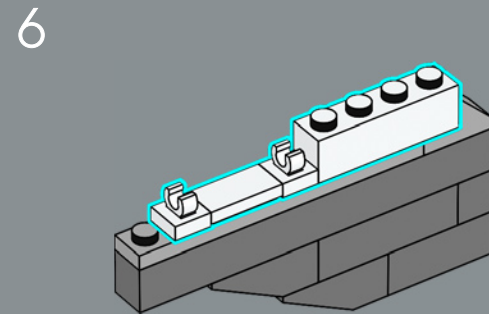
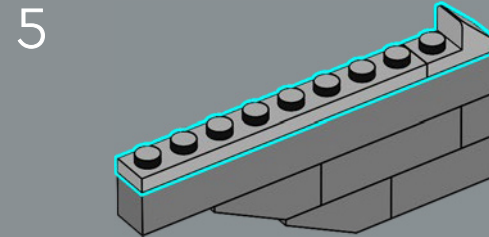
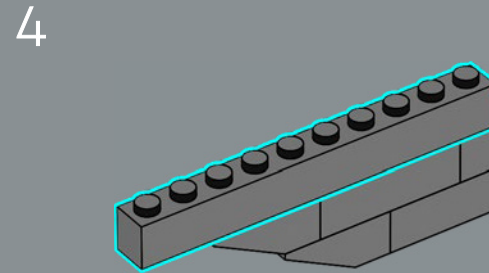
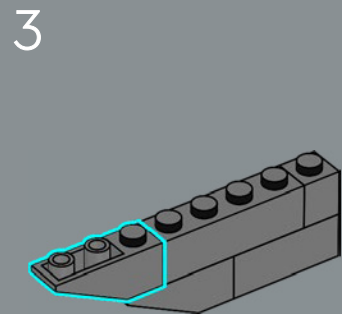
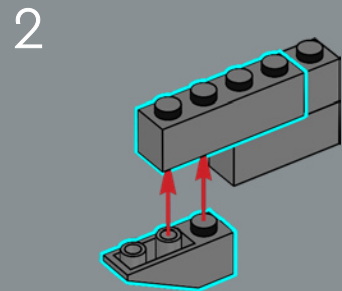
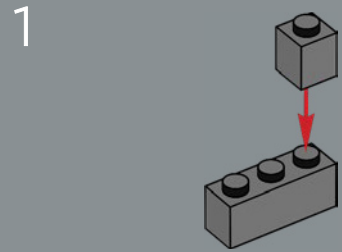

2x

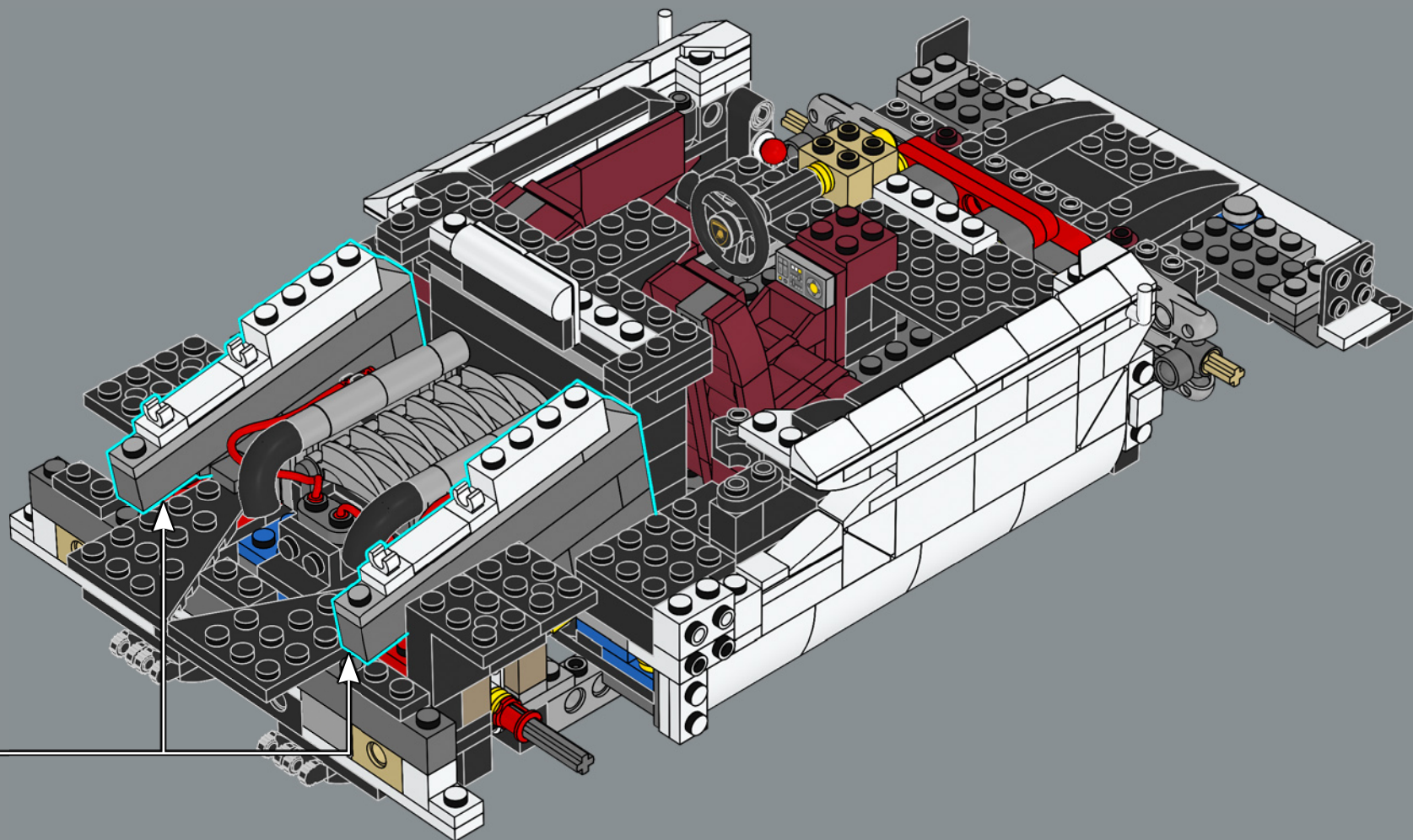



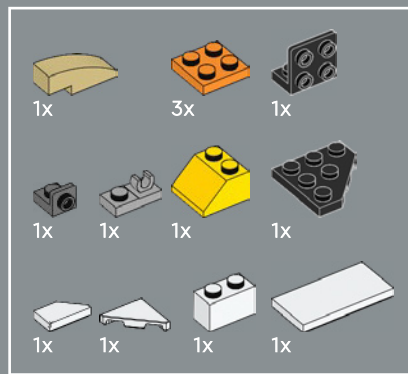

191

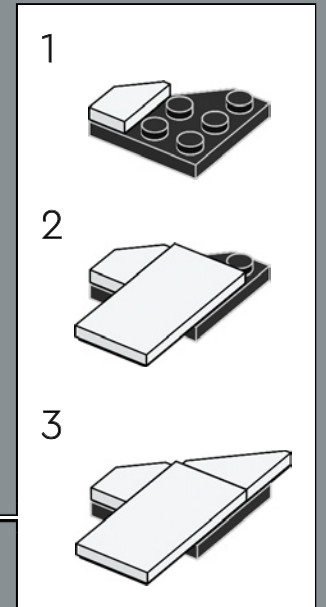
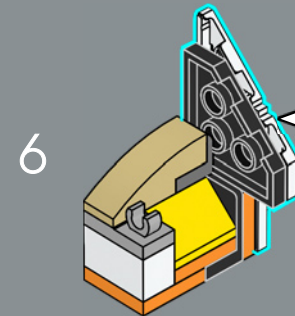
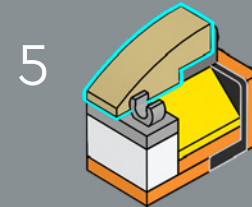
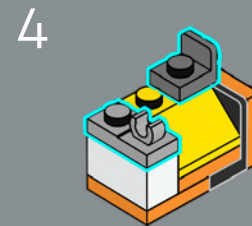
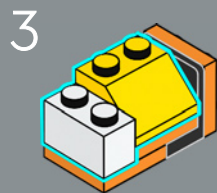
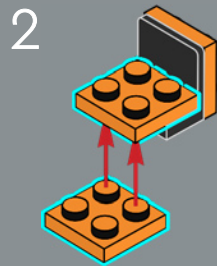
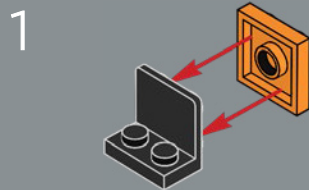

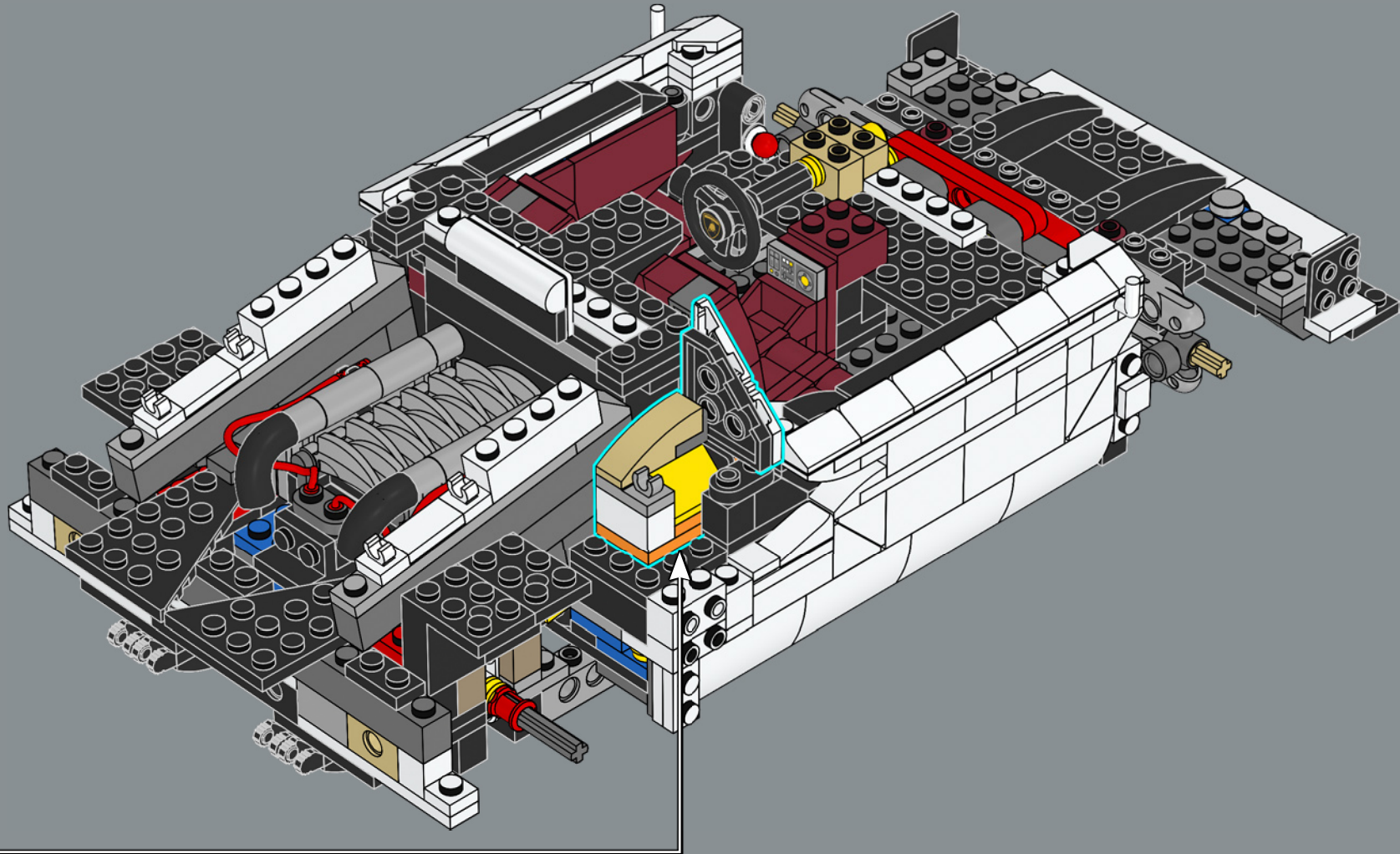

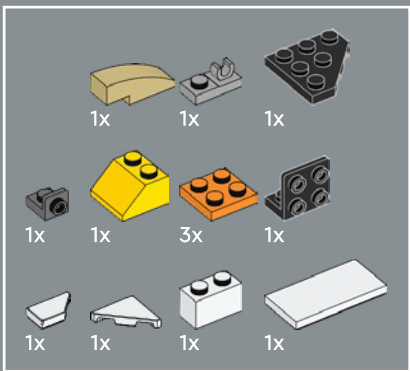

192

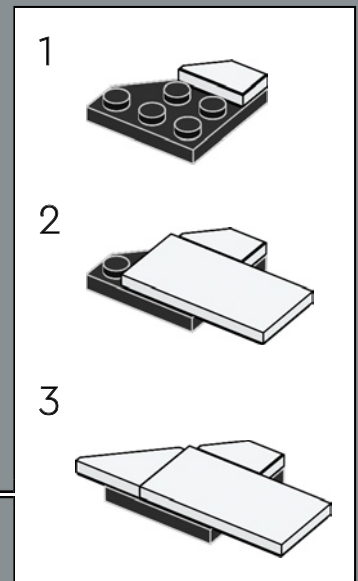
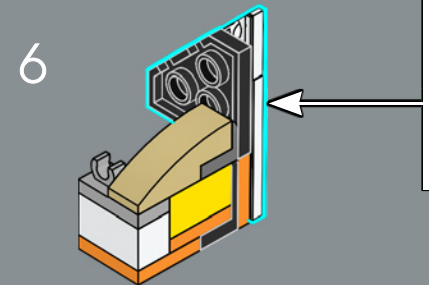
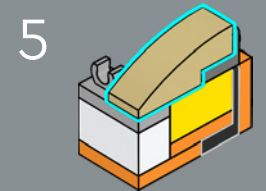
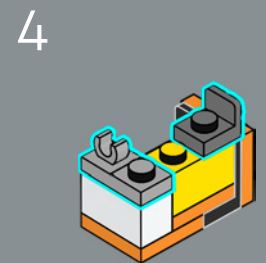
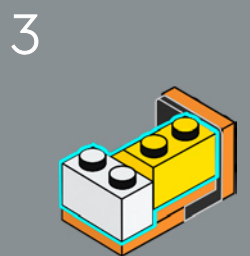
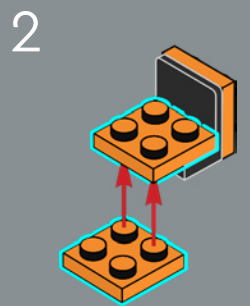
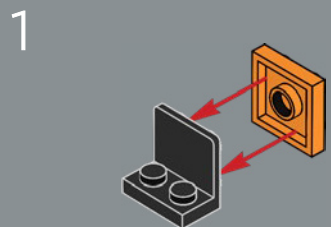

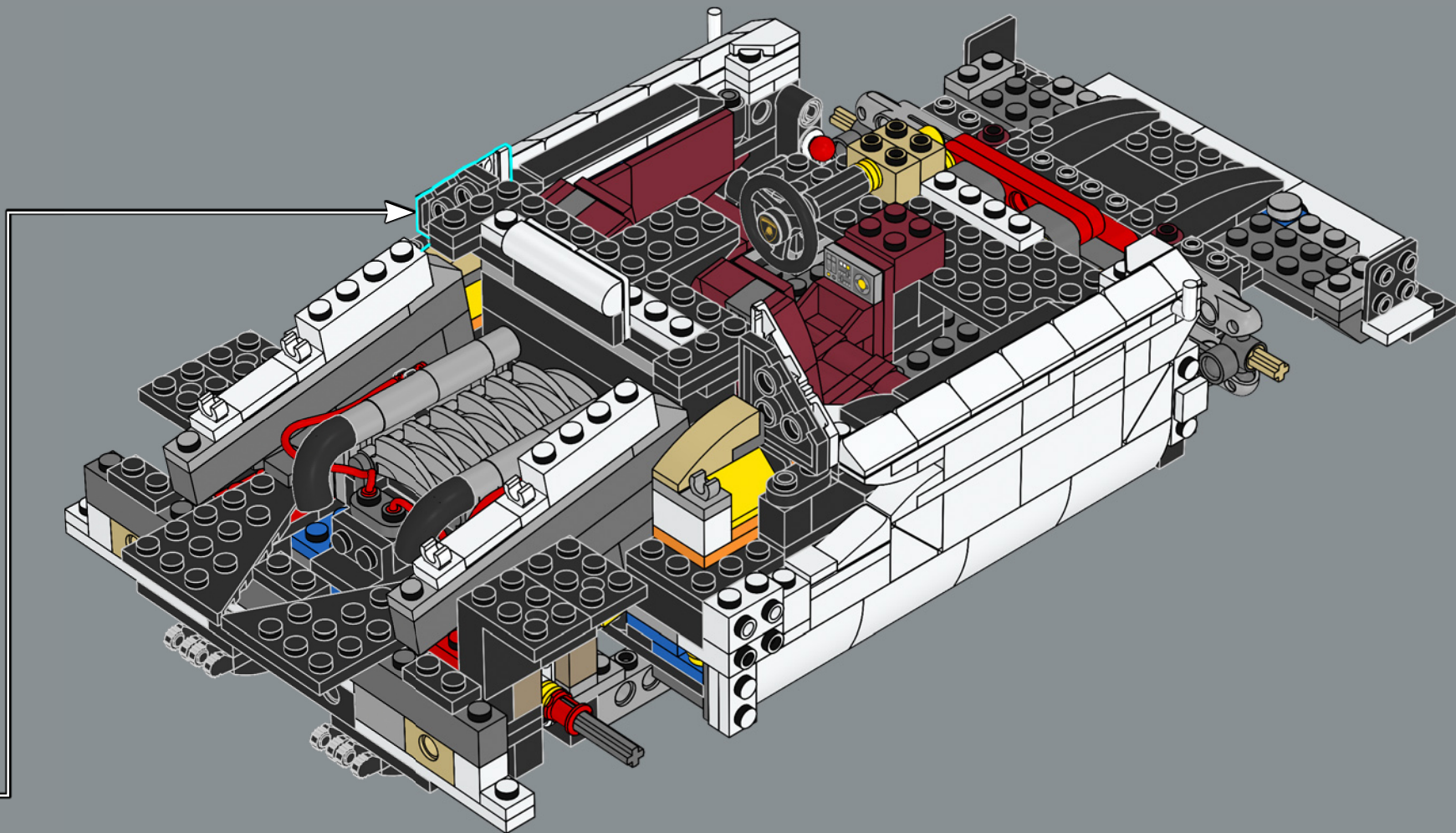



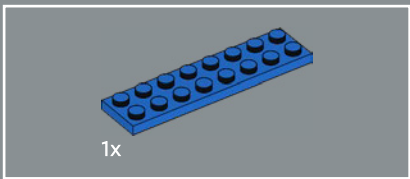

193

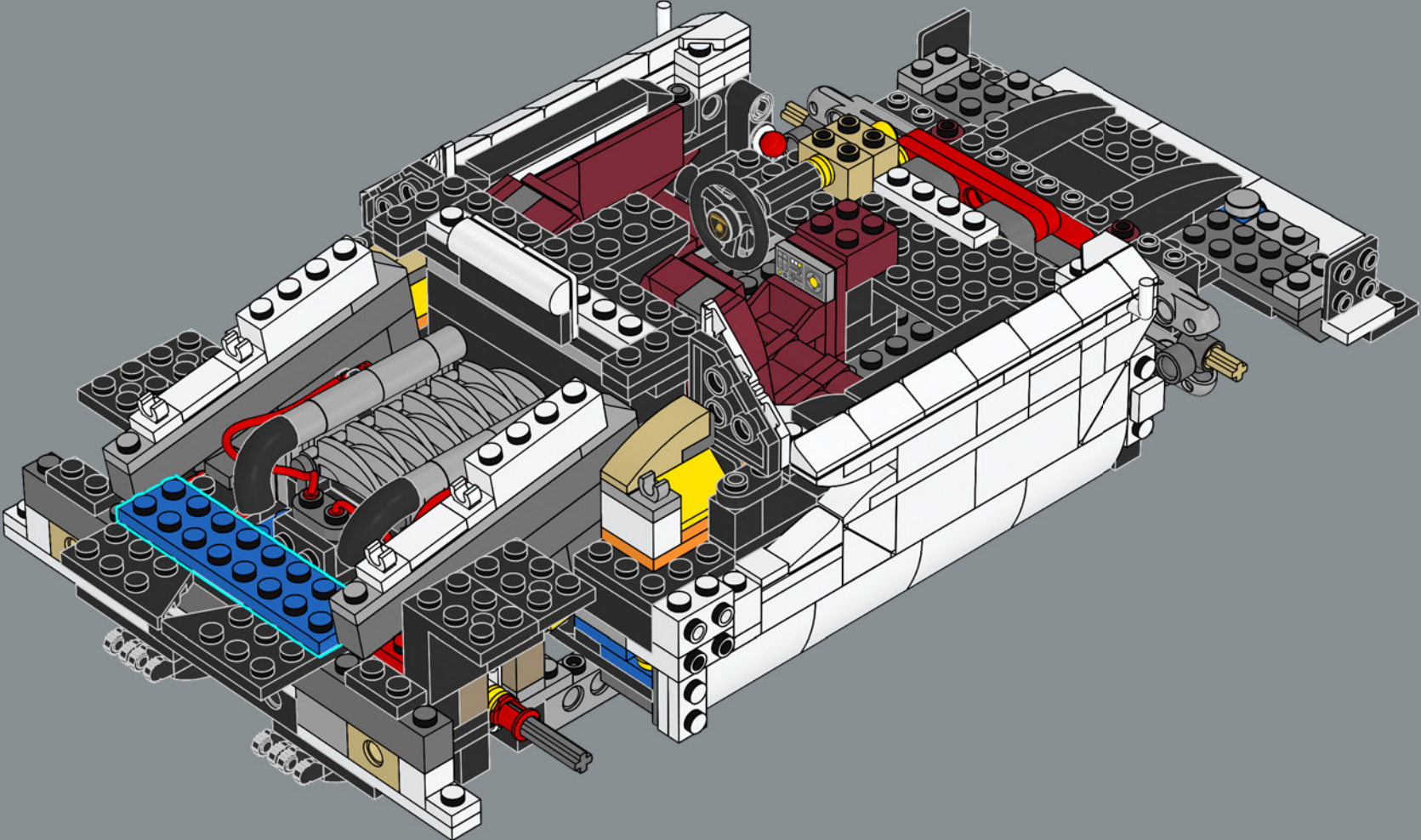

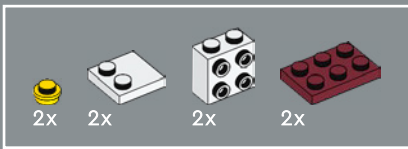

194

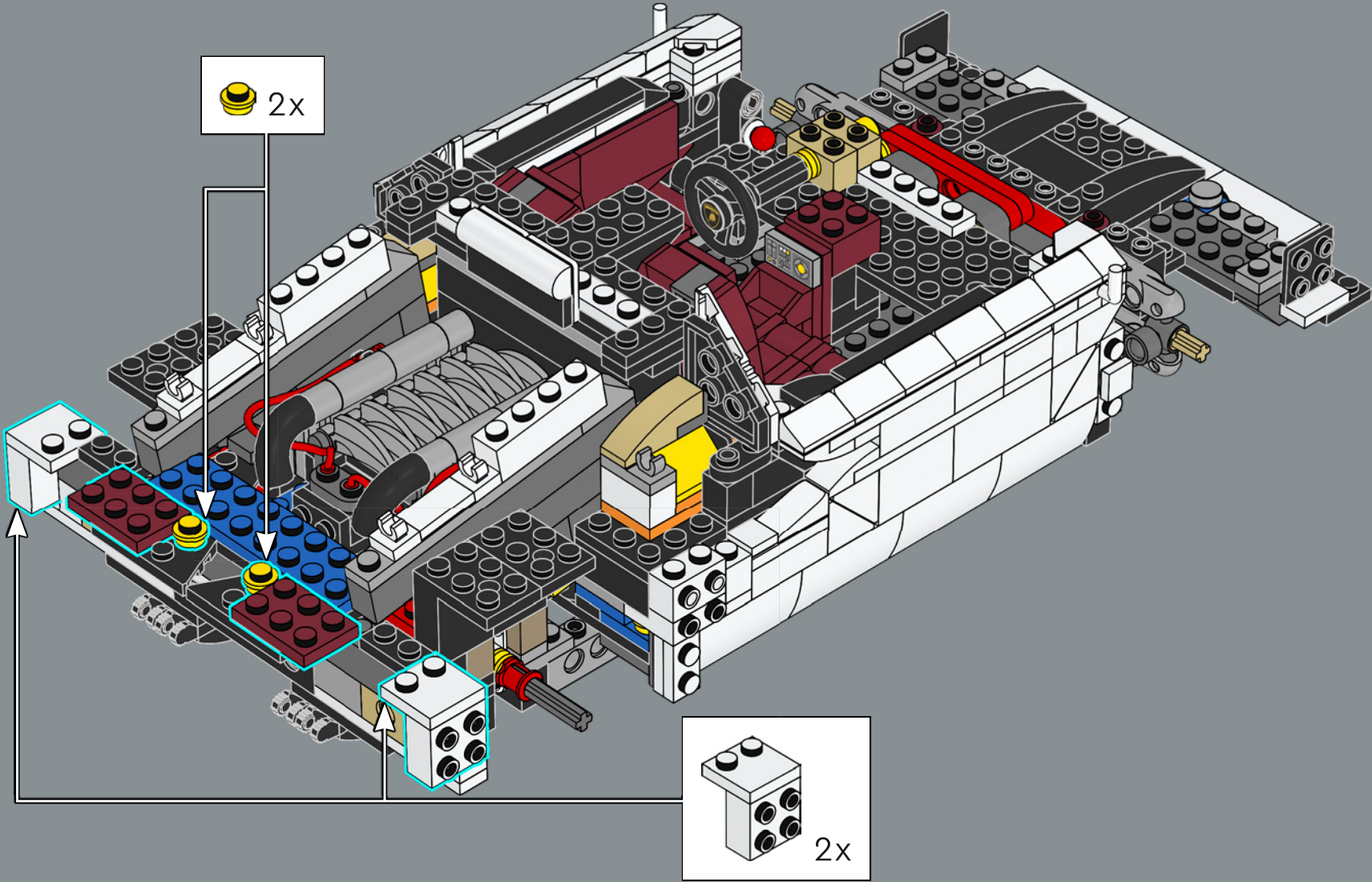





2x

195

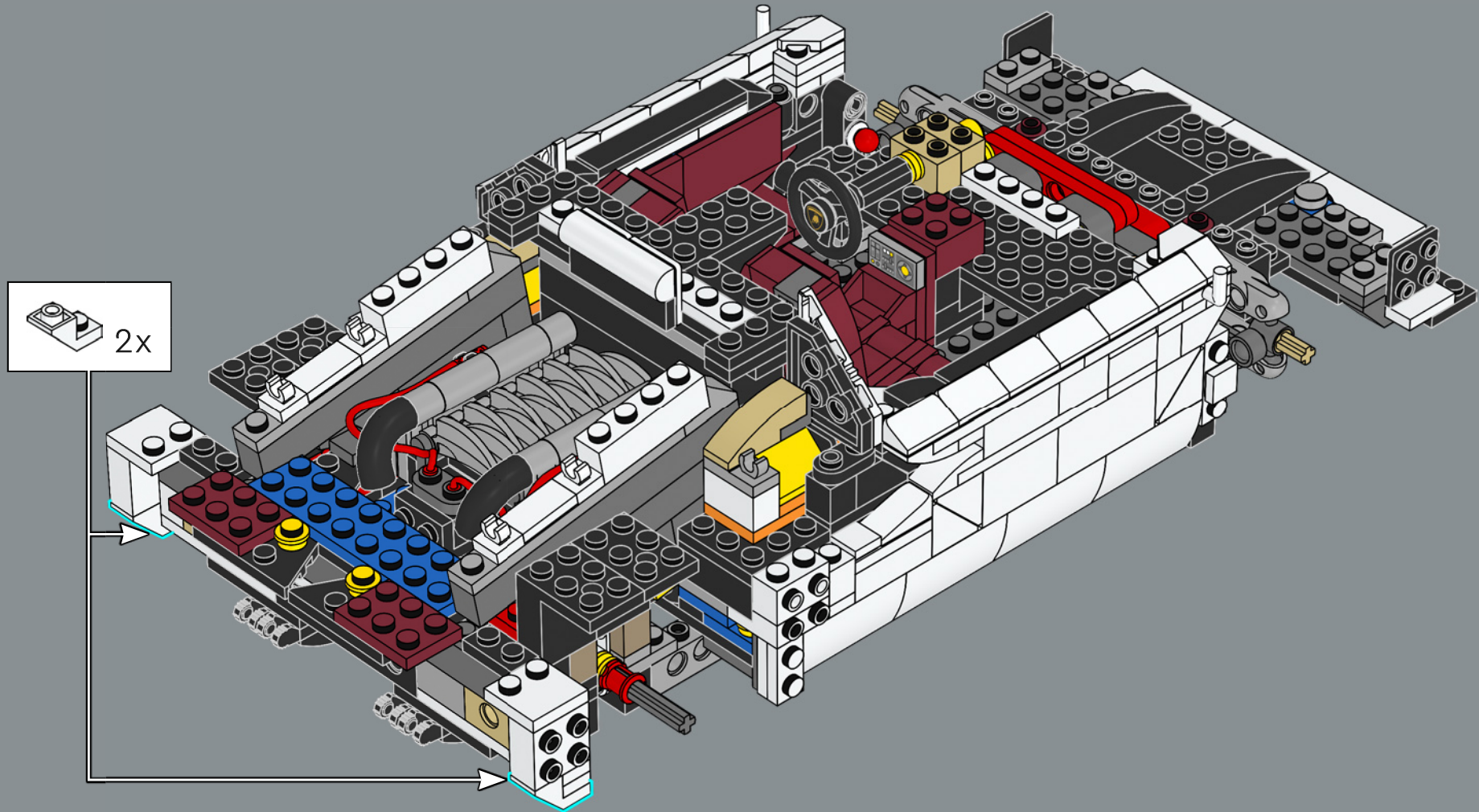

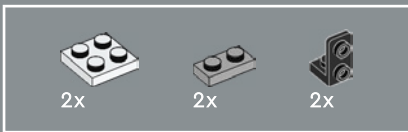

196

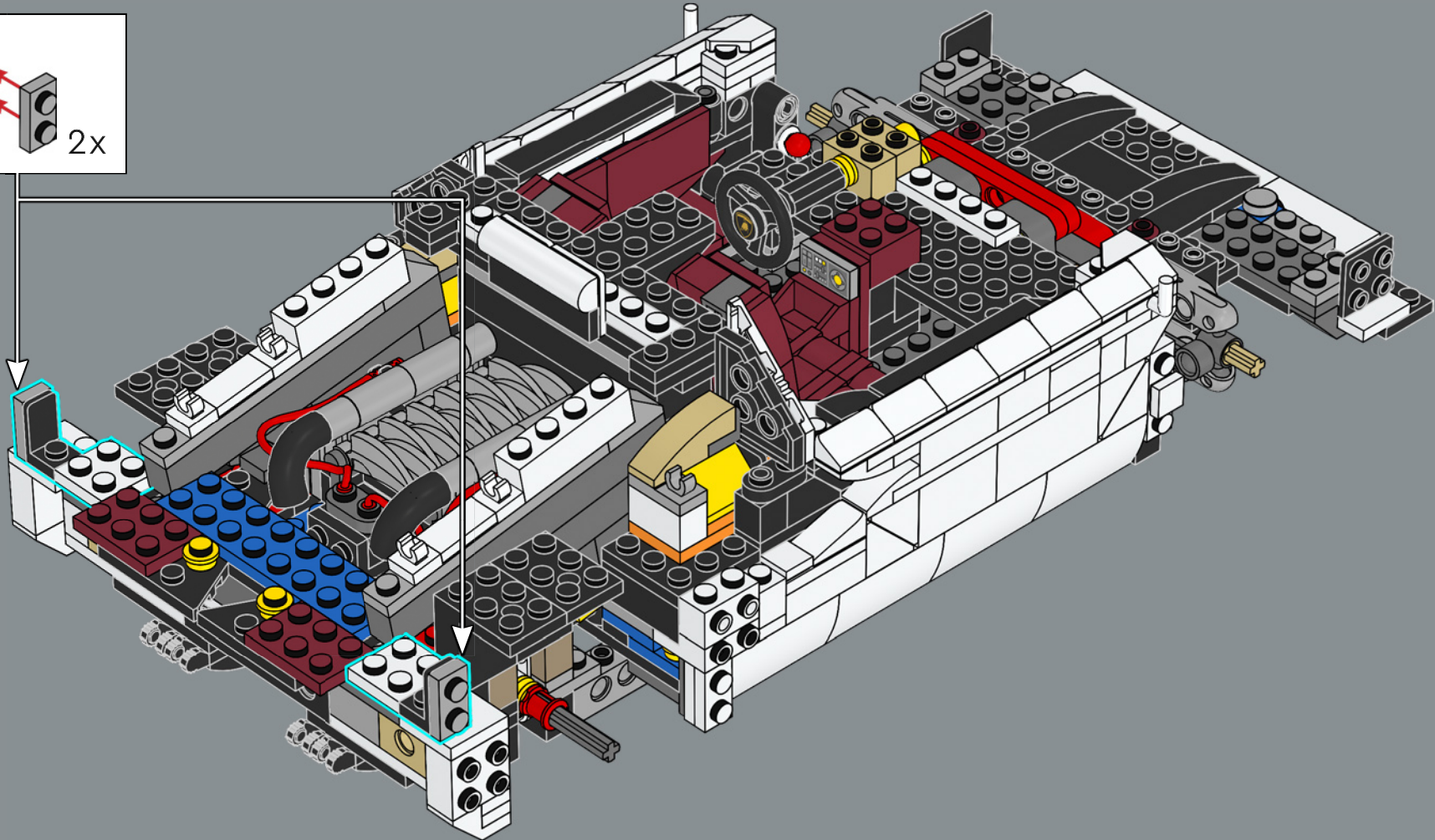
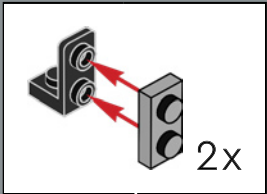



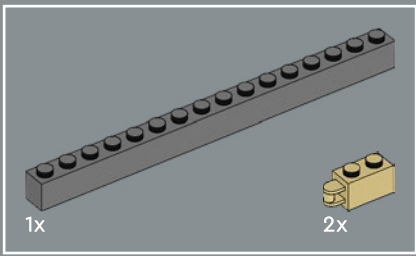

197

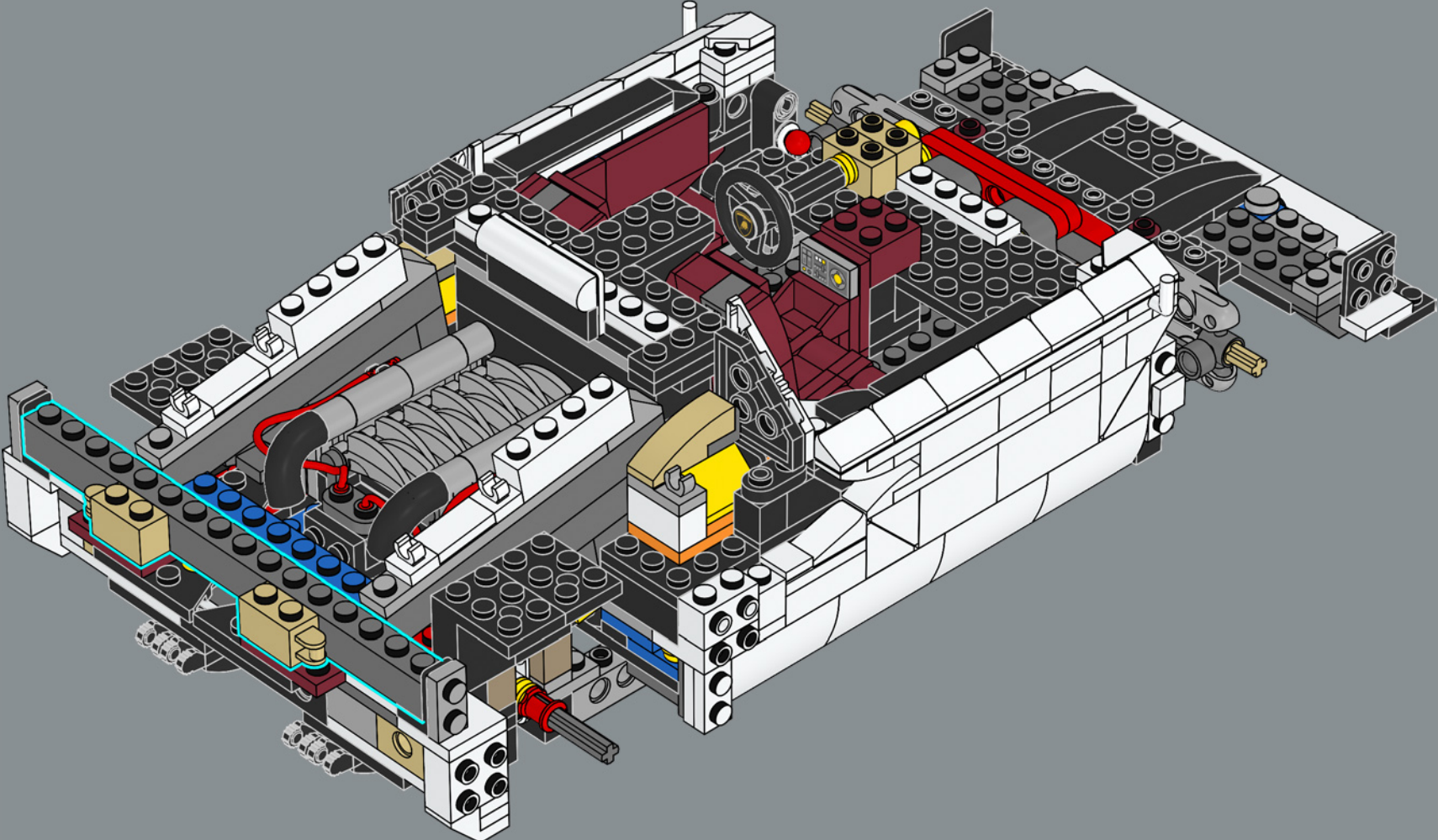

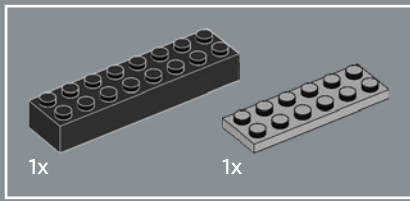

198

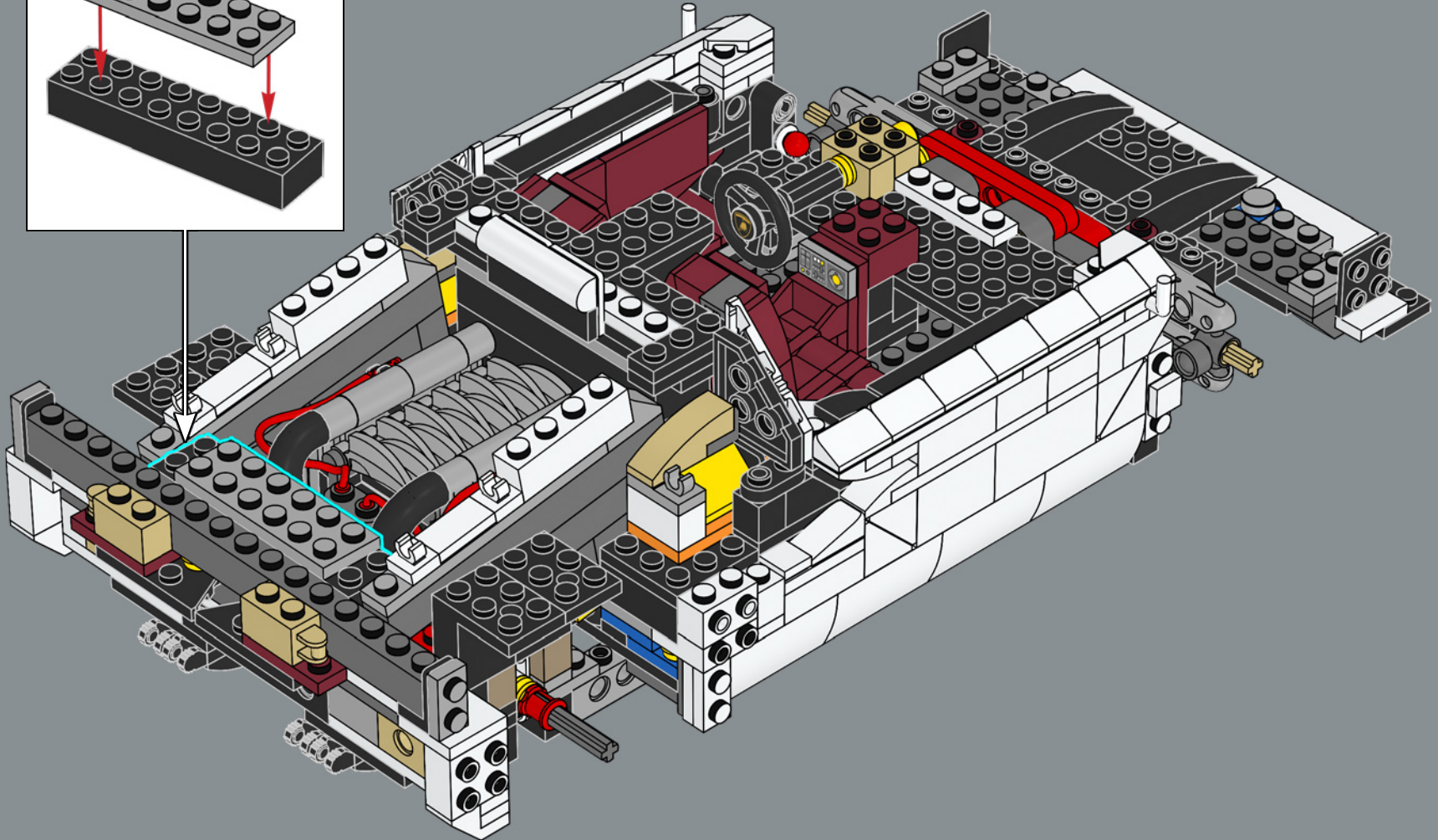
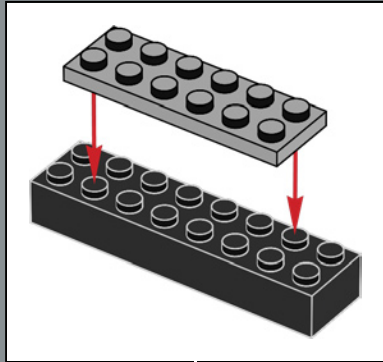

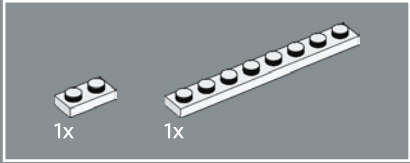
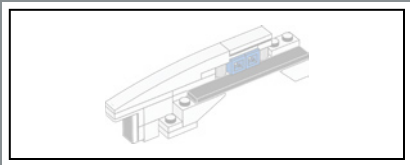

199

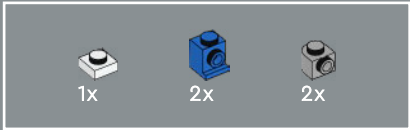
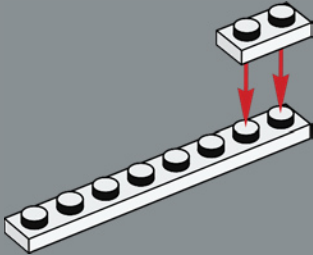

200

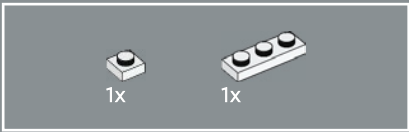
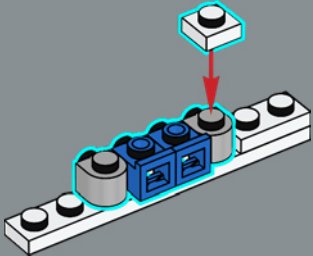

201

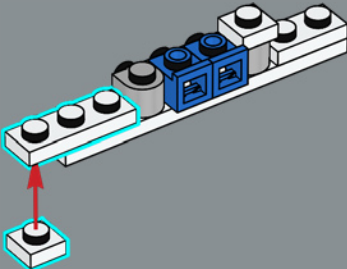

202

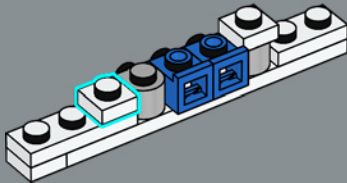

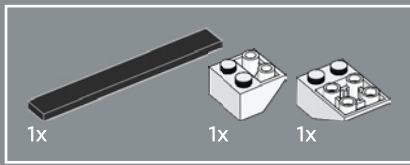

203

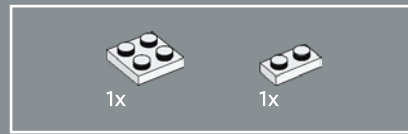
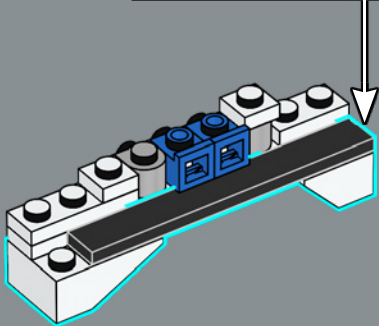
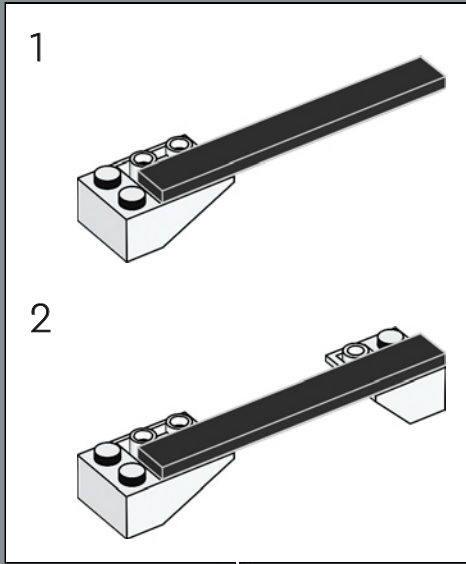

204

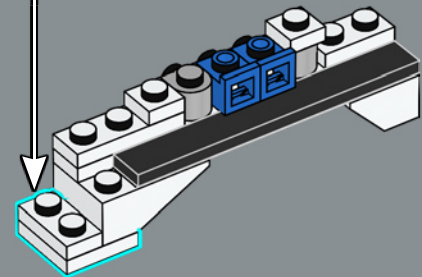
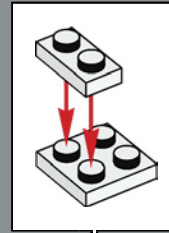



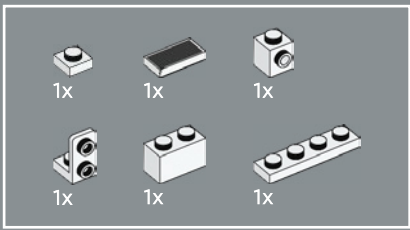

205

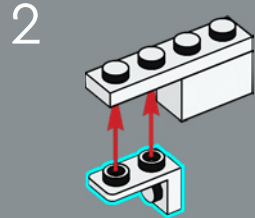
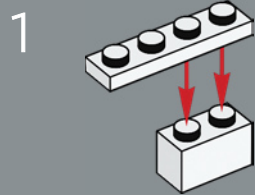

3

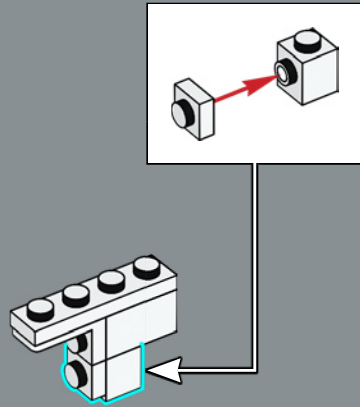

4

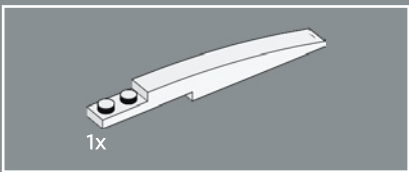
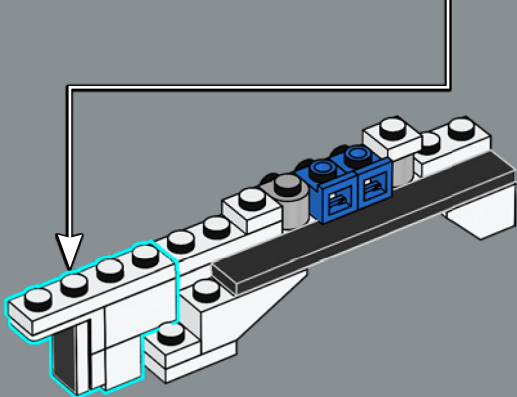
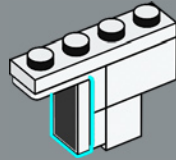

206

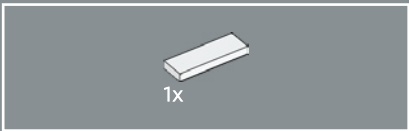
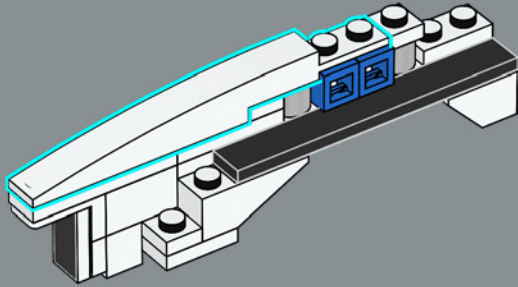

207

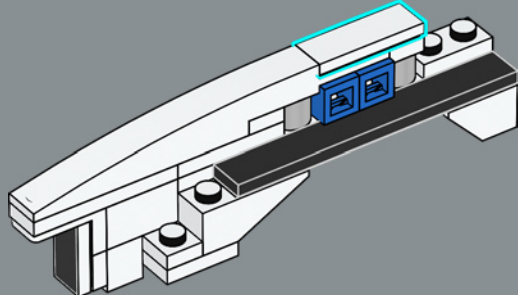

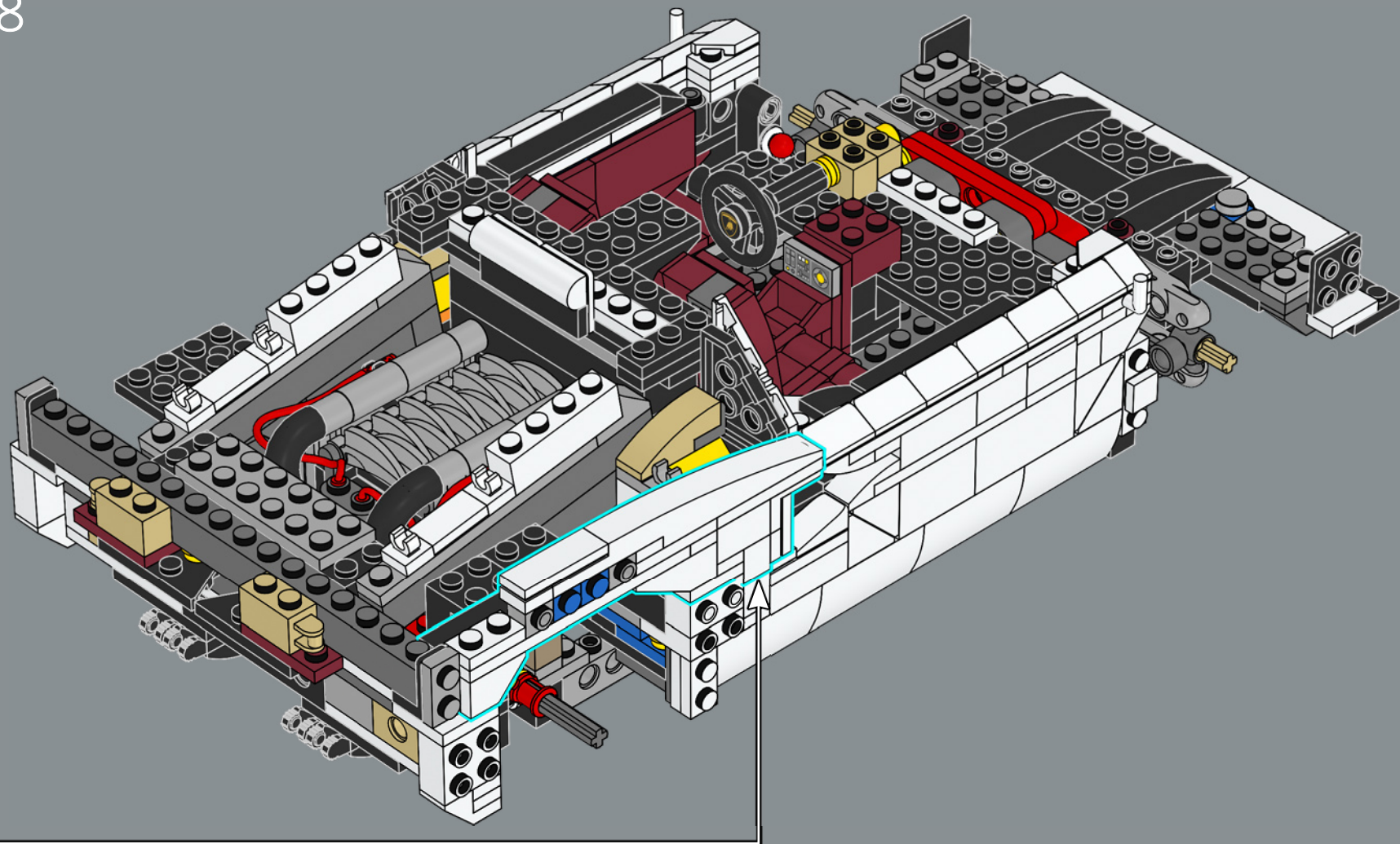

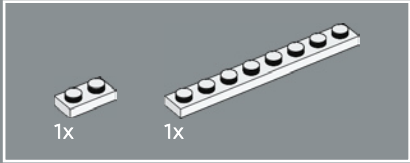
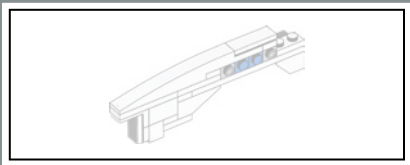

209

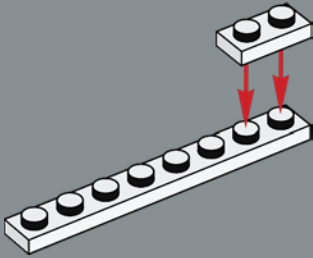

210

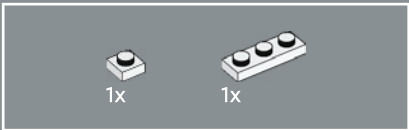
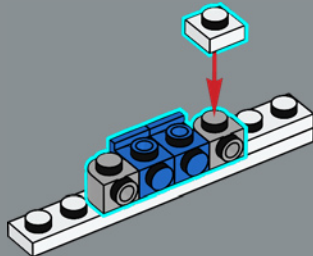

211

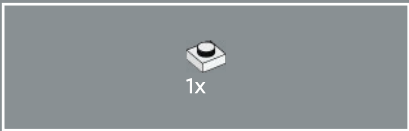
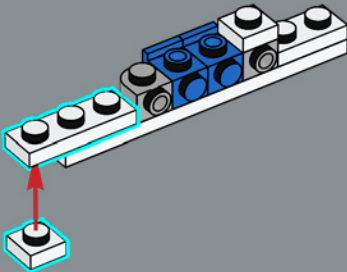

212

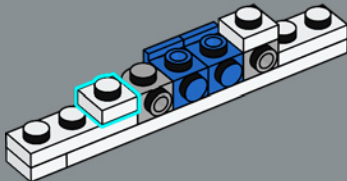

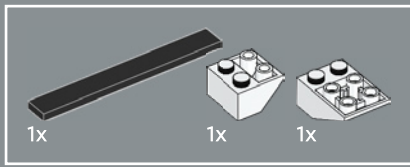

213

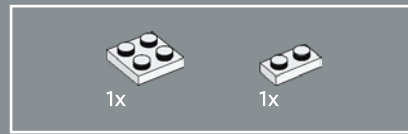
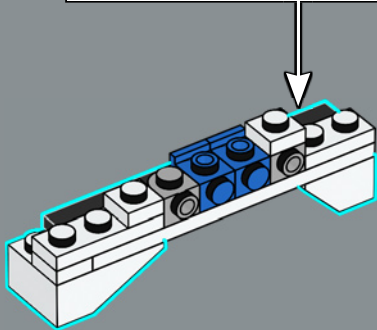
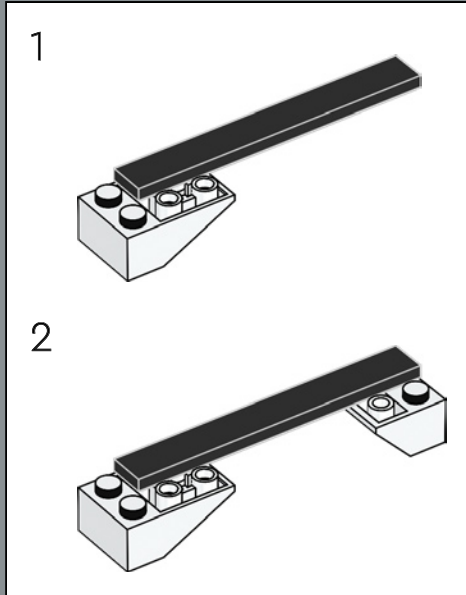

214

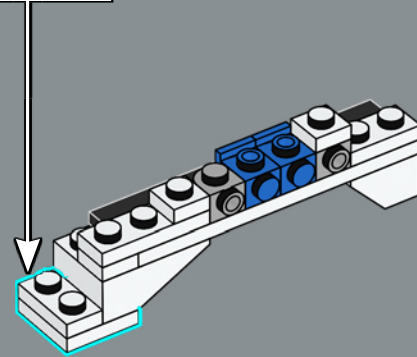
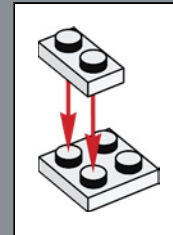



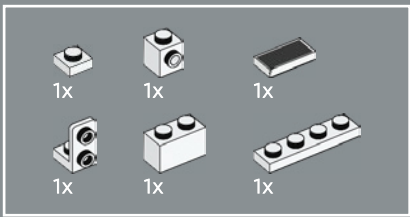

# 215

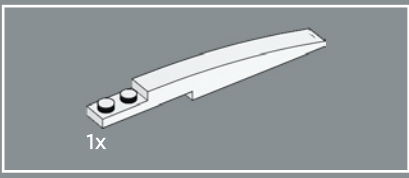
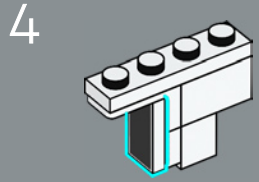
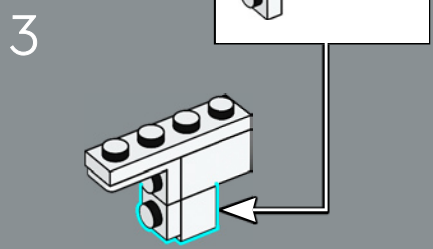
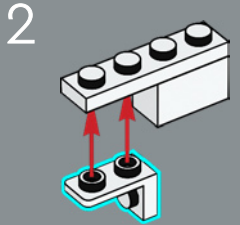
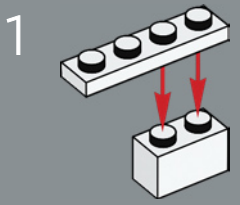

# 216

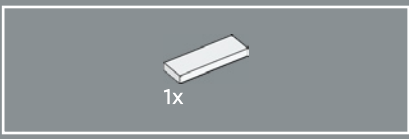
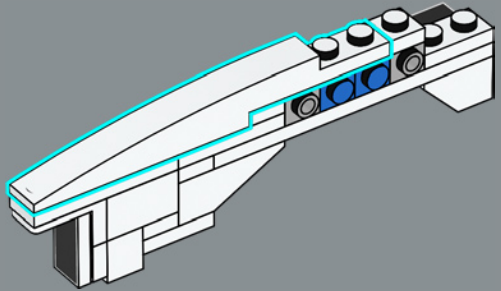

# 217

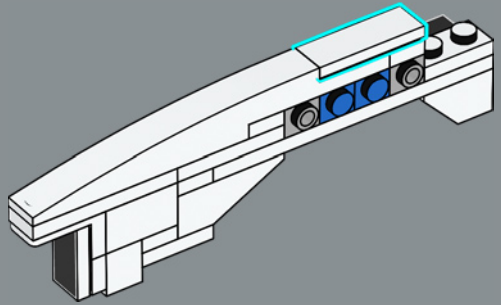

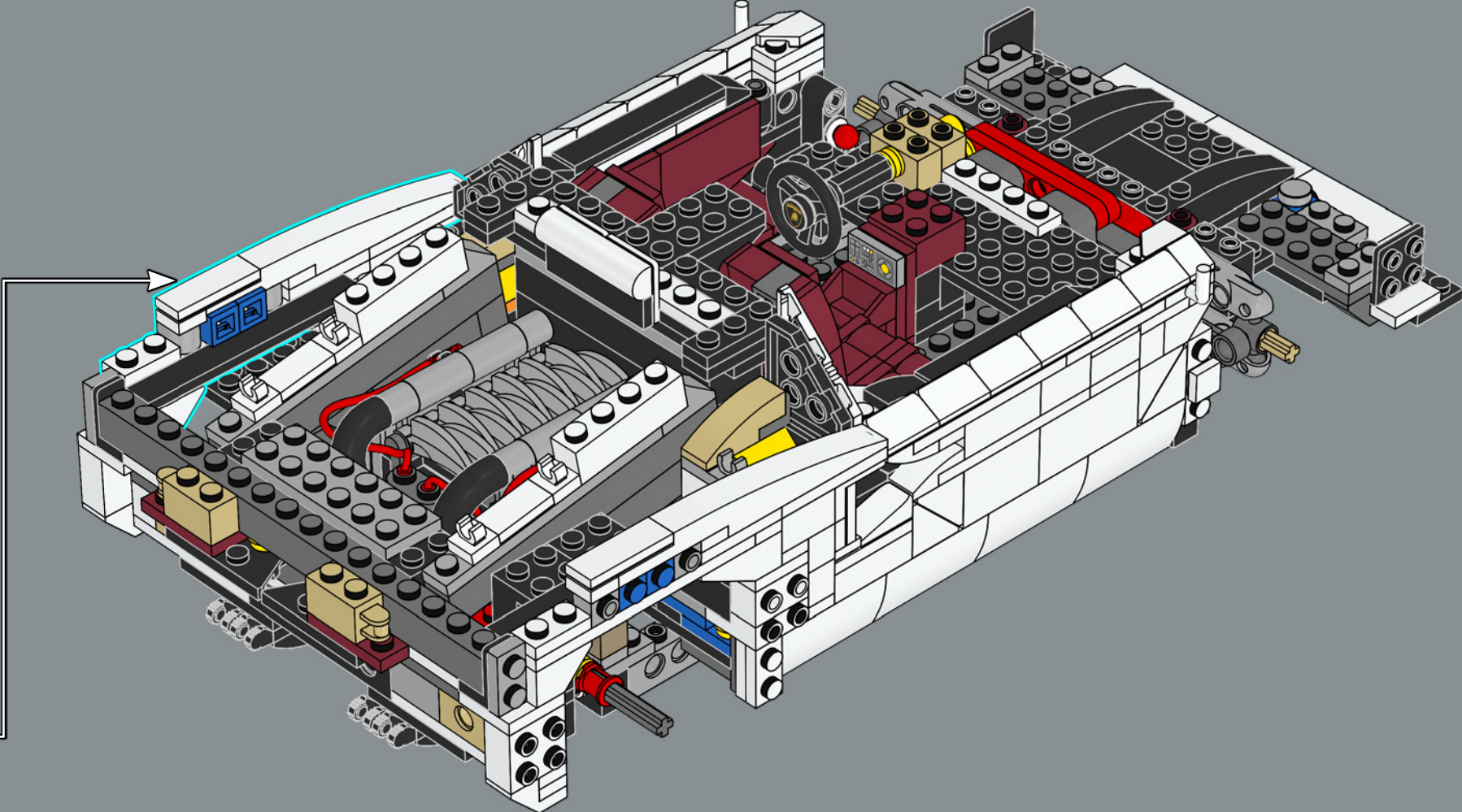

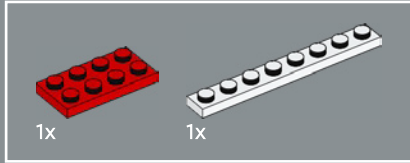
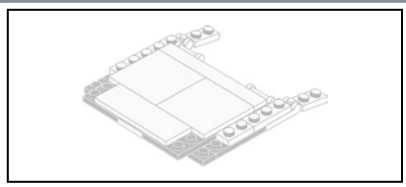

219

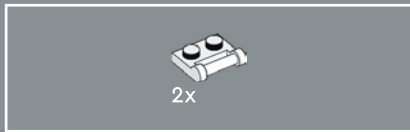
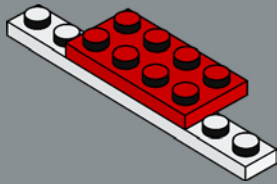

220

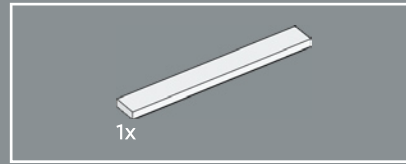
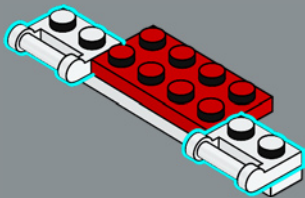

221

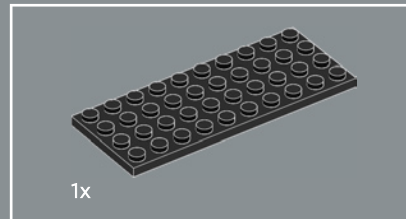
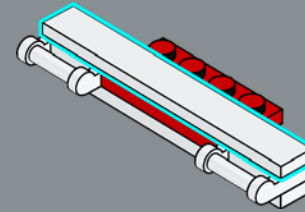

222

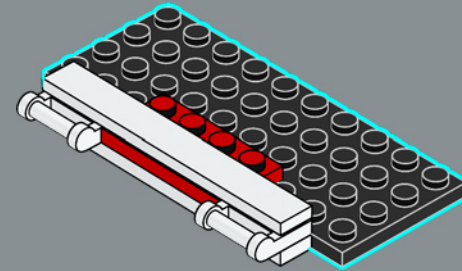

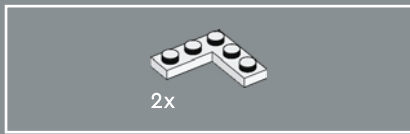

223

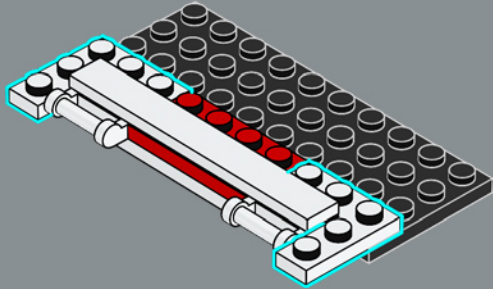

224

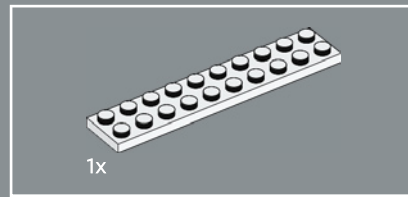
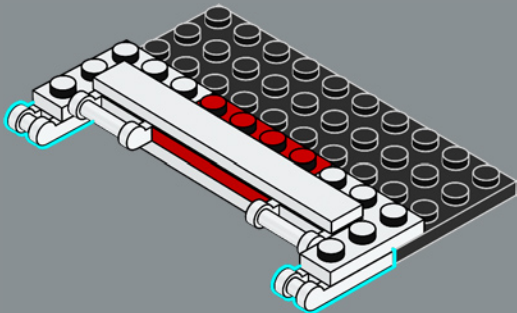

225

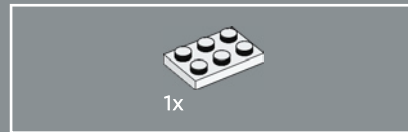
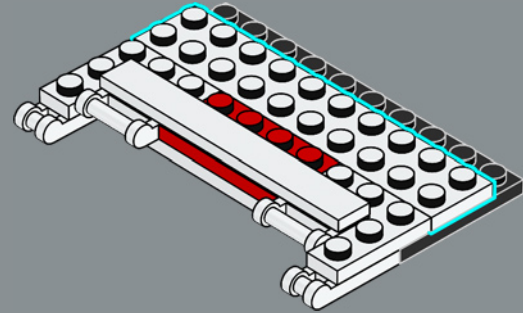

226

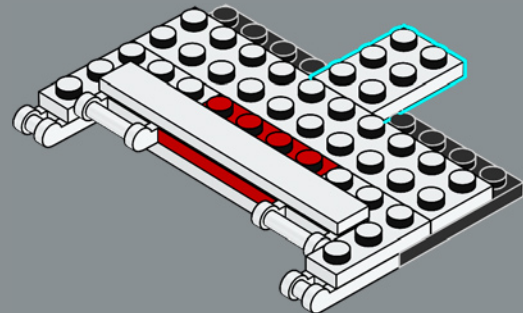



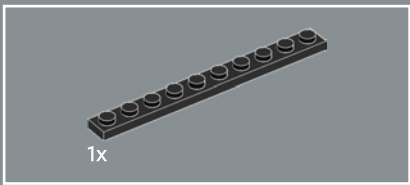

227

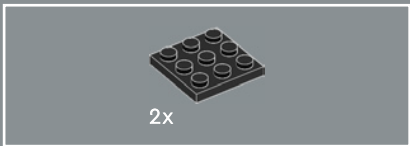
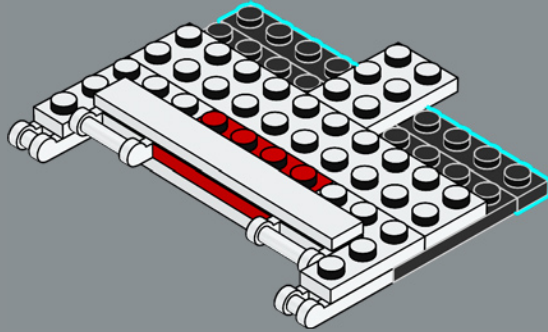

228

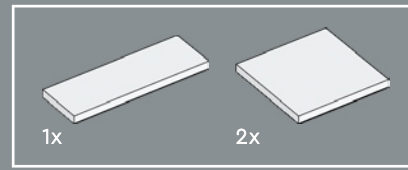
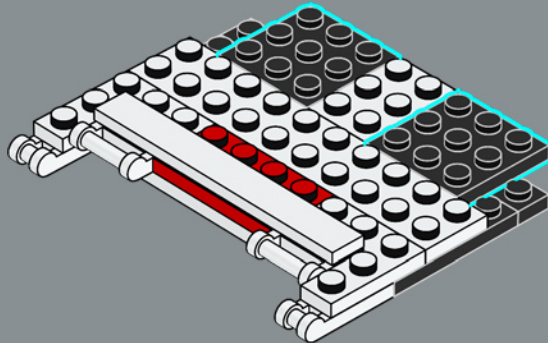

229

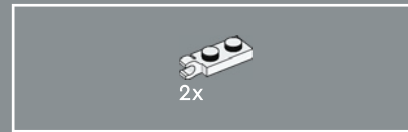
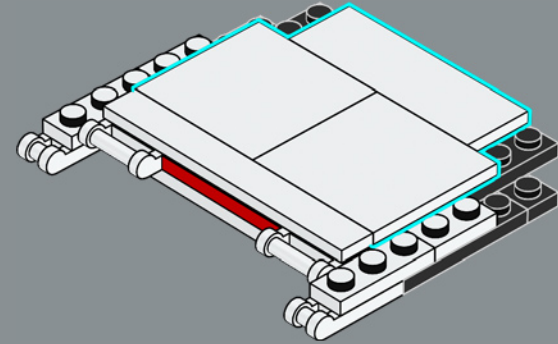

230

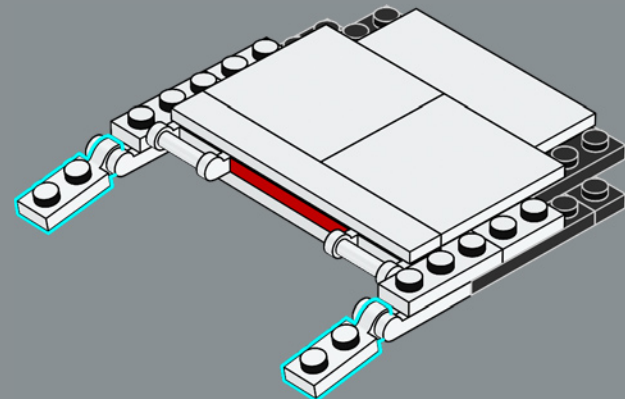

231

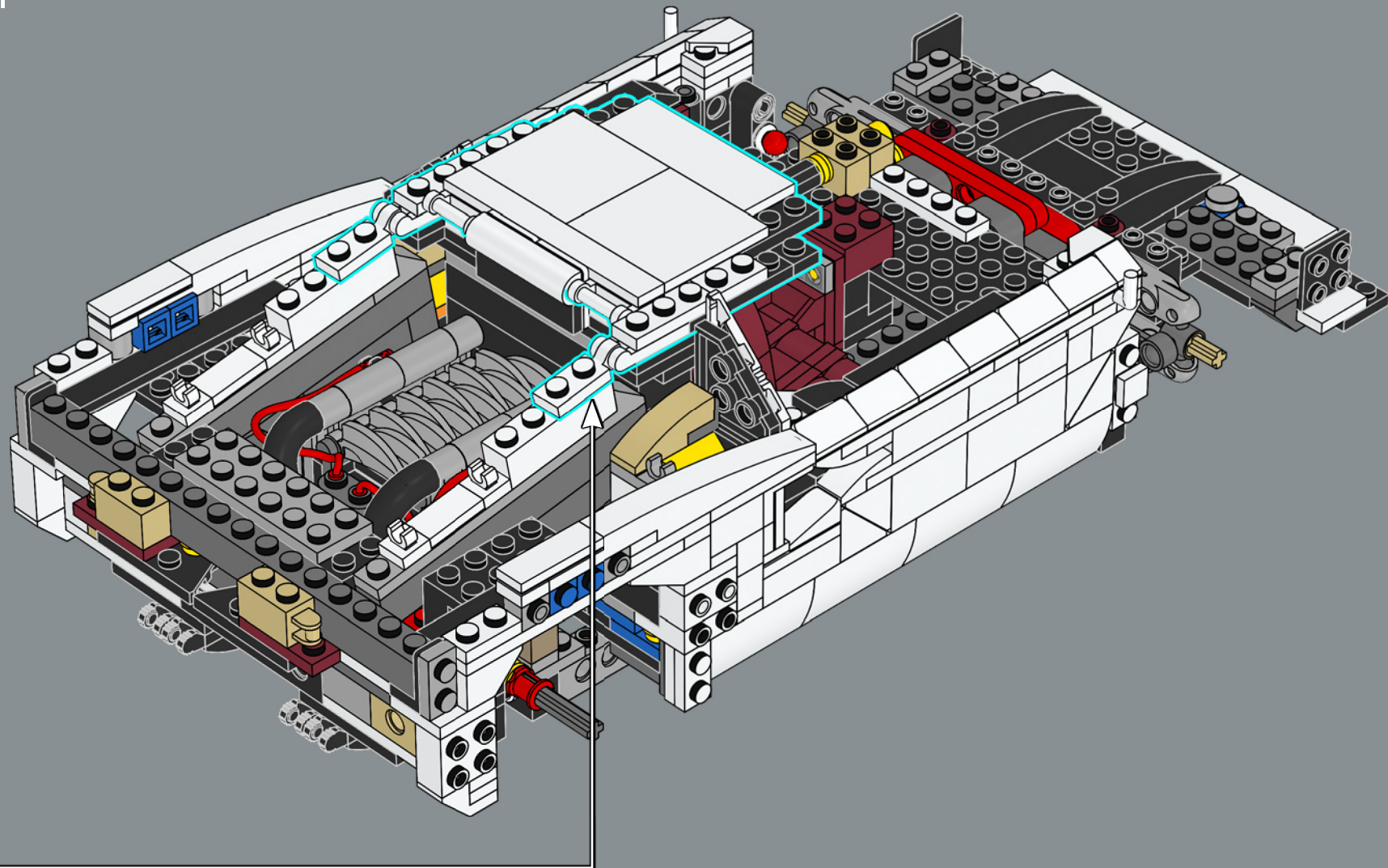

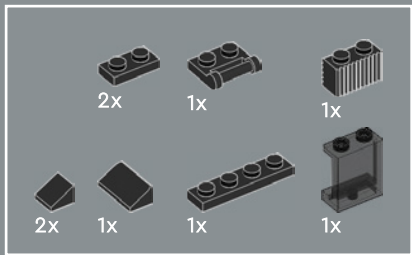

232

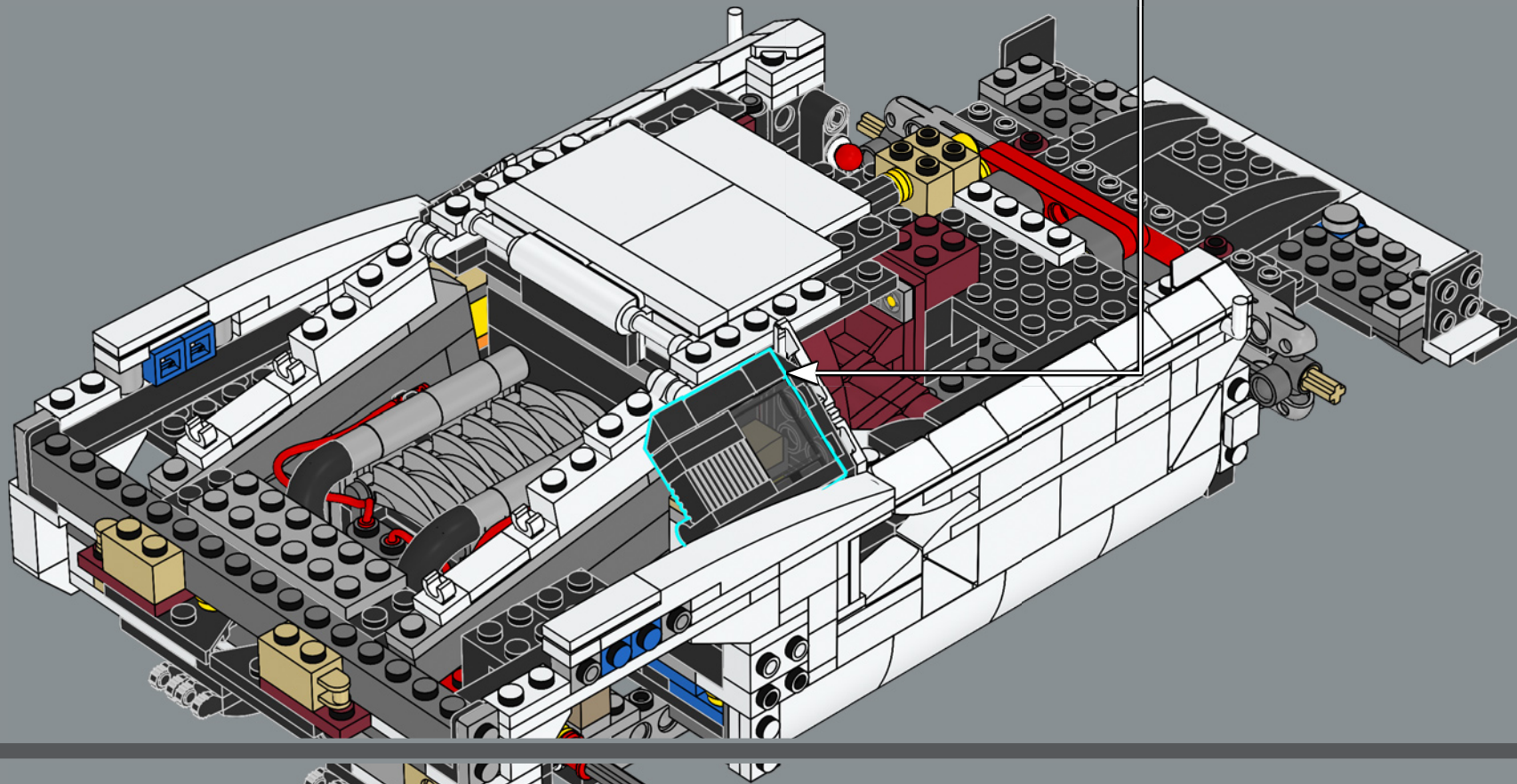
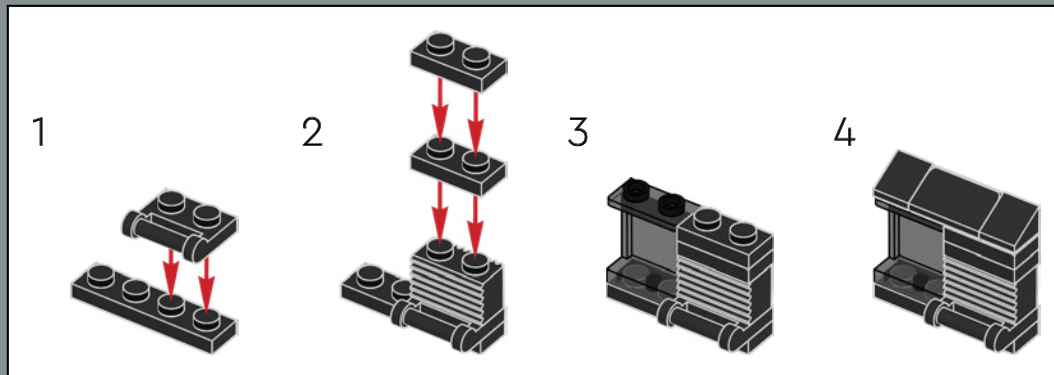



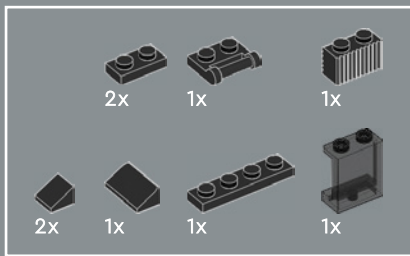

233

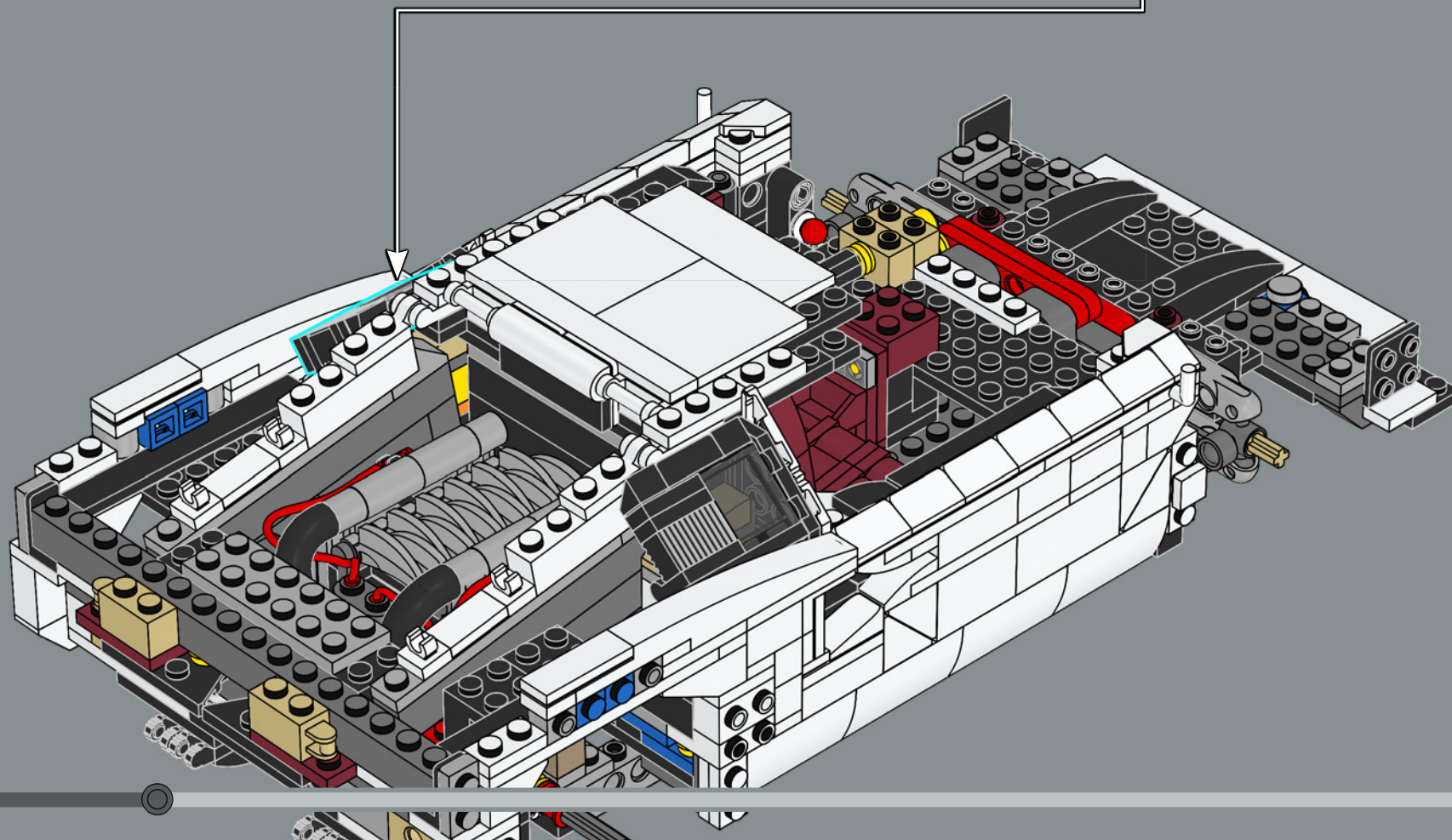
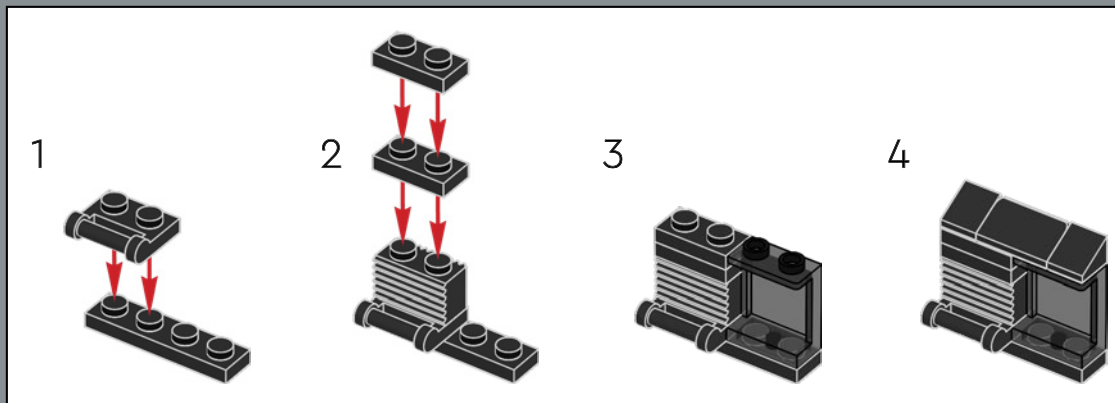



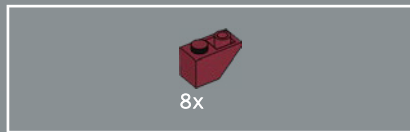

234

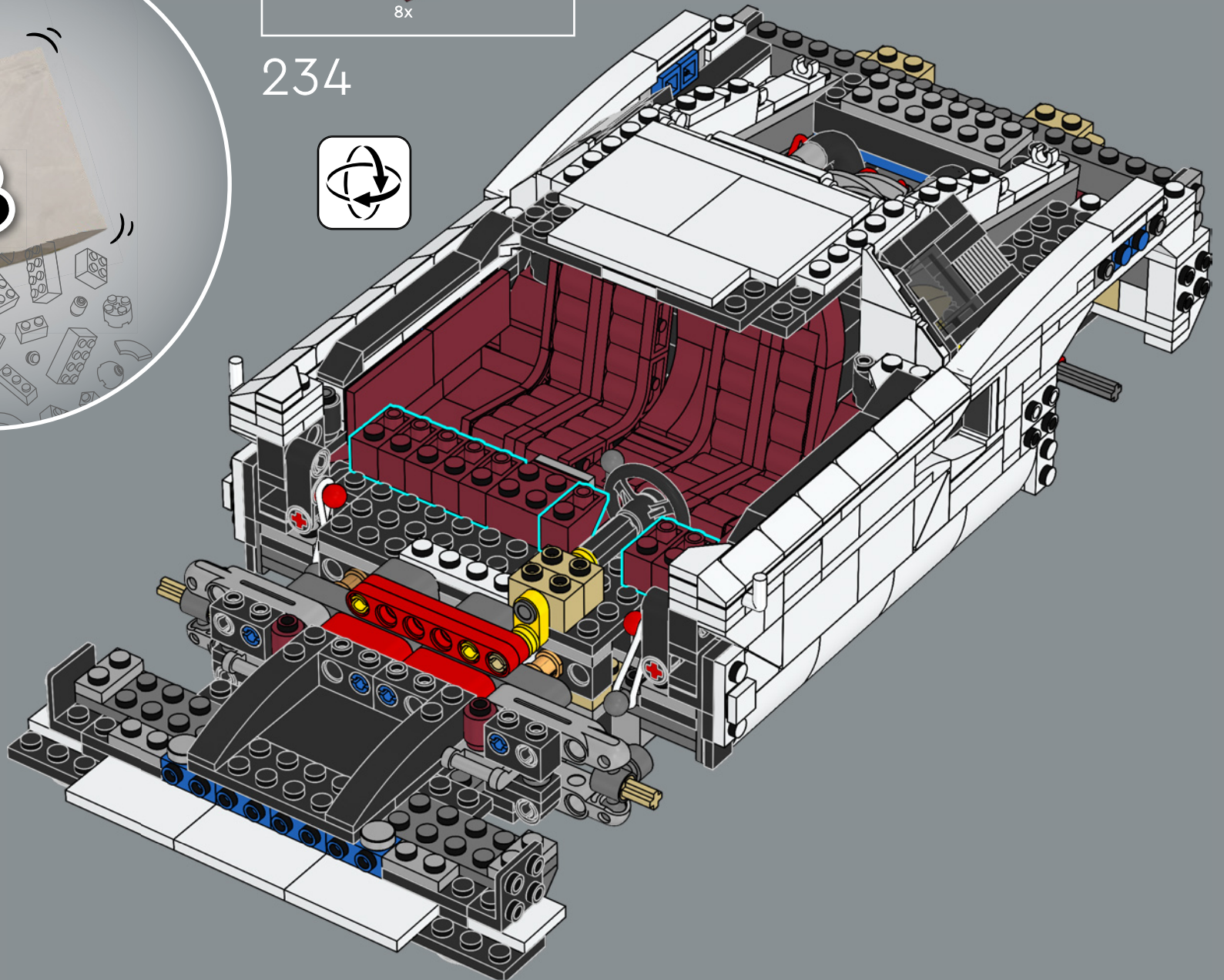

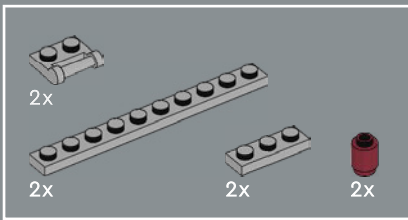

235

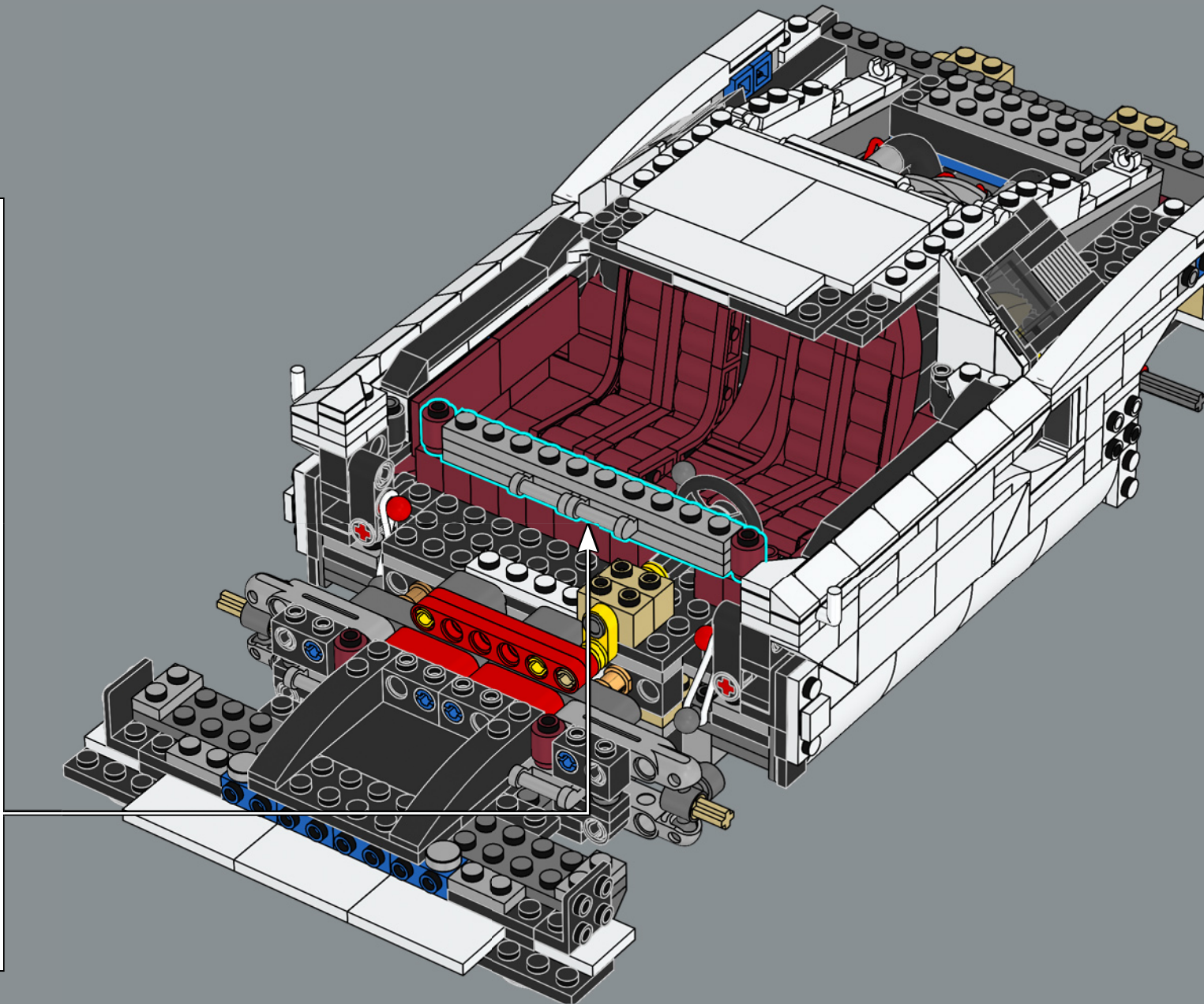
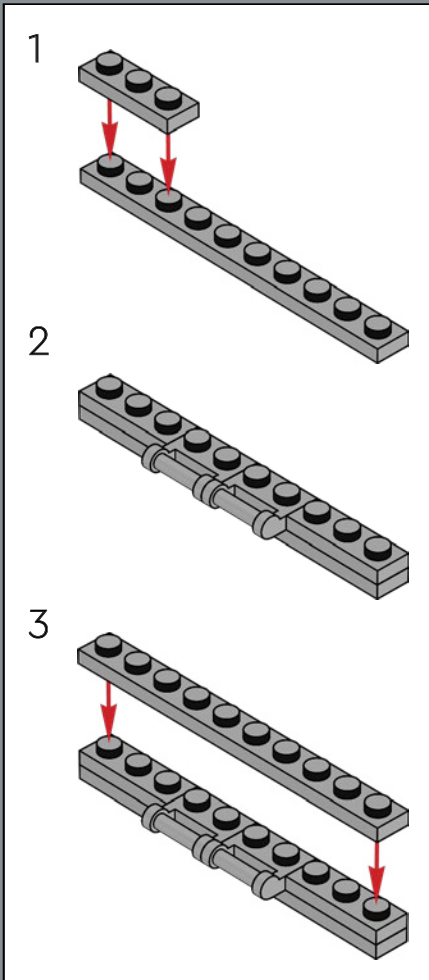



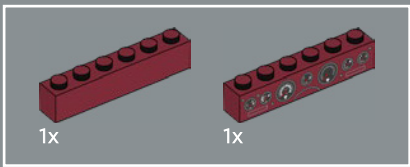

236

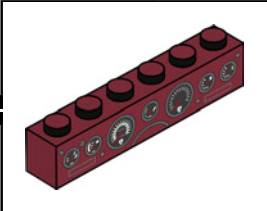
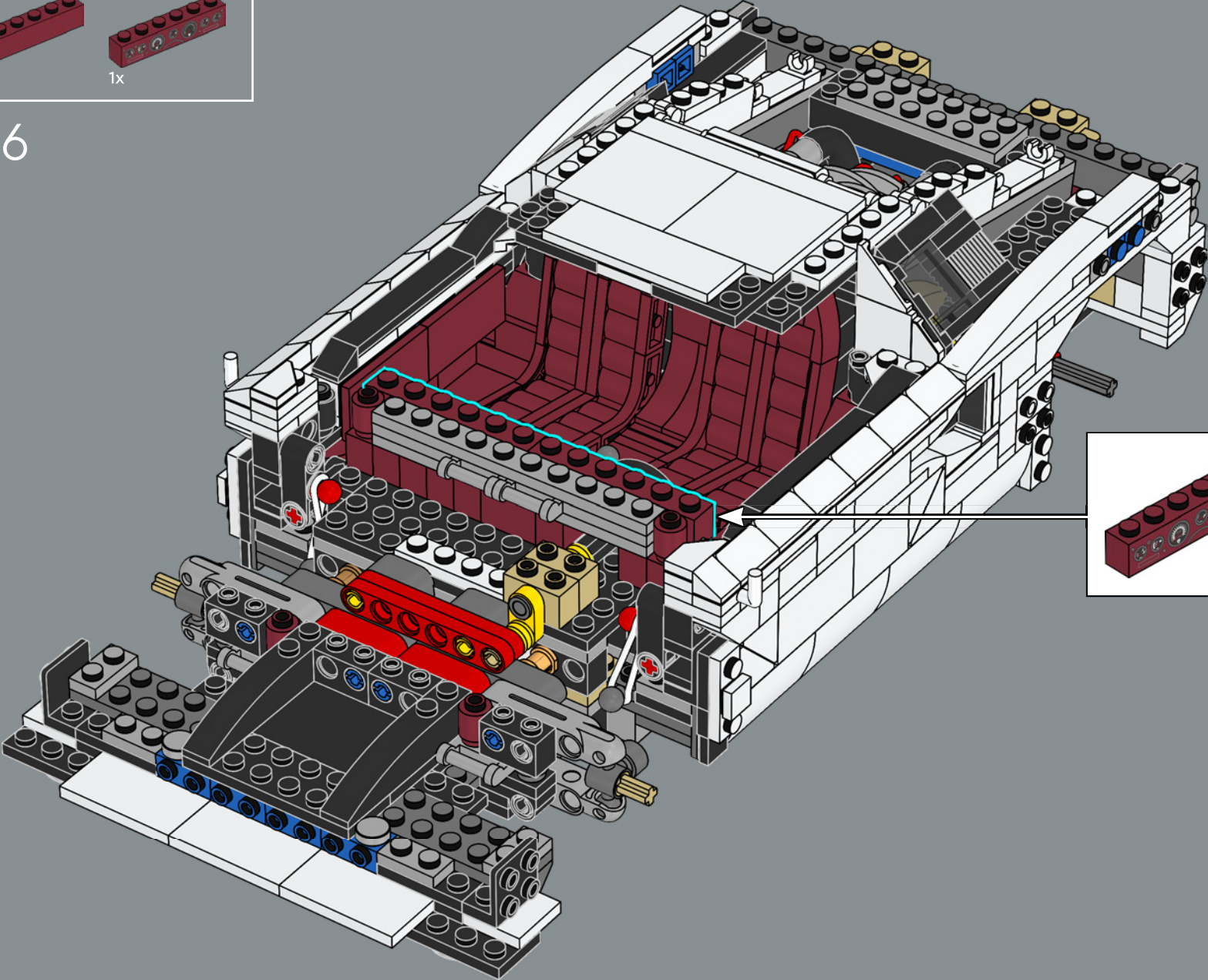

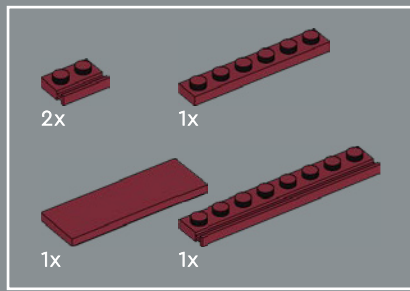

237

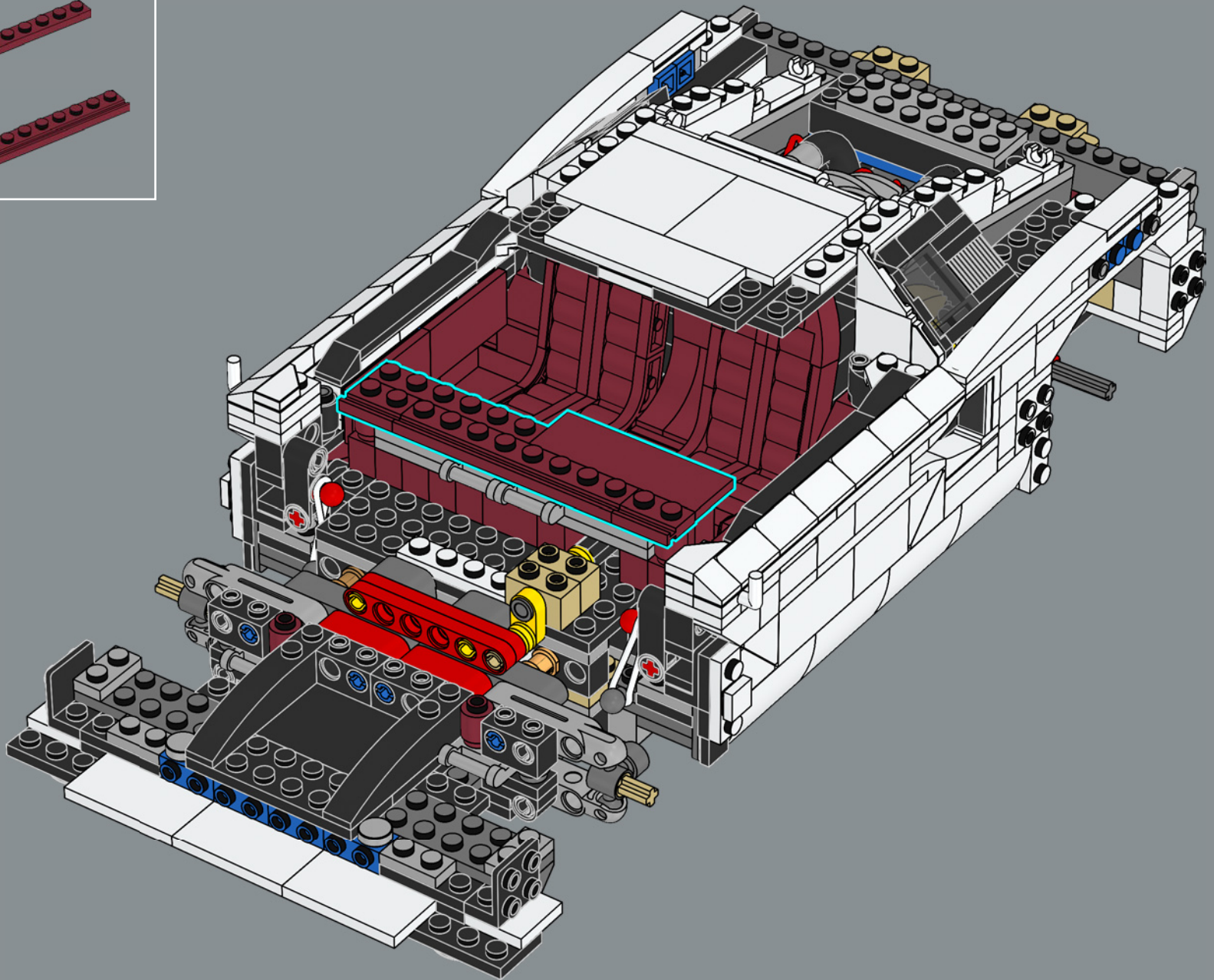



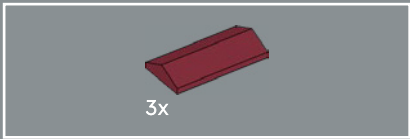

238

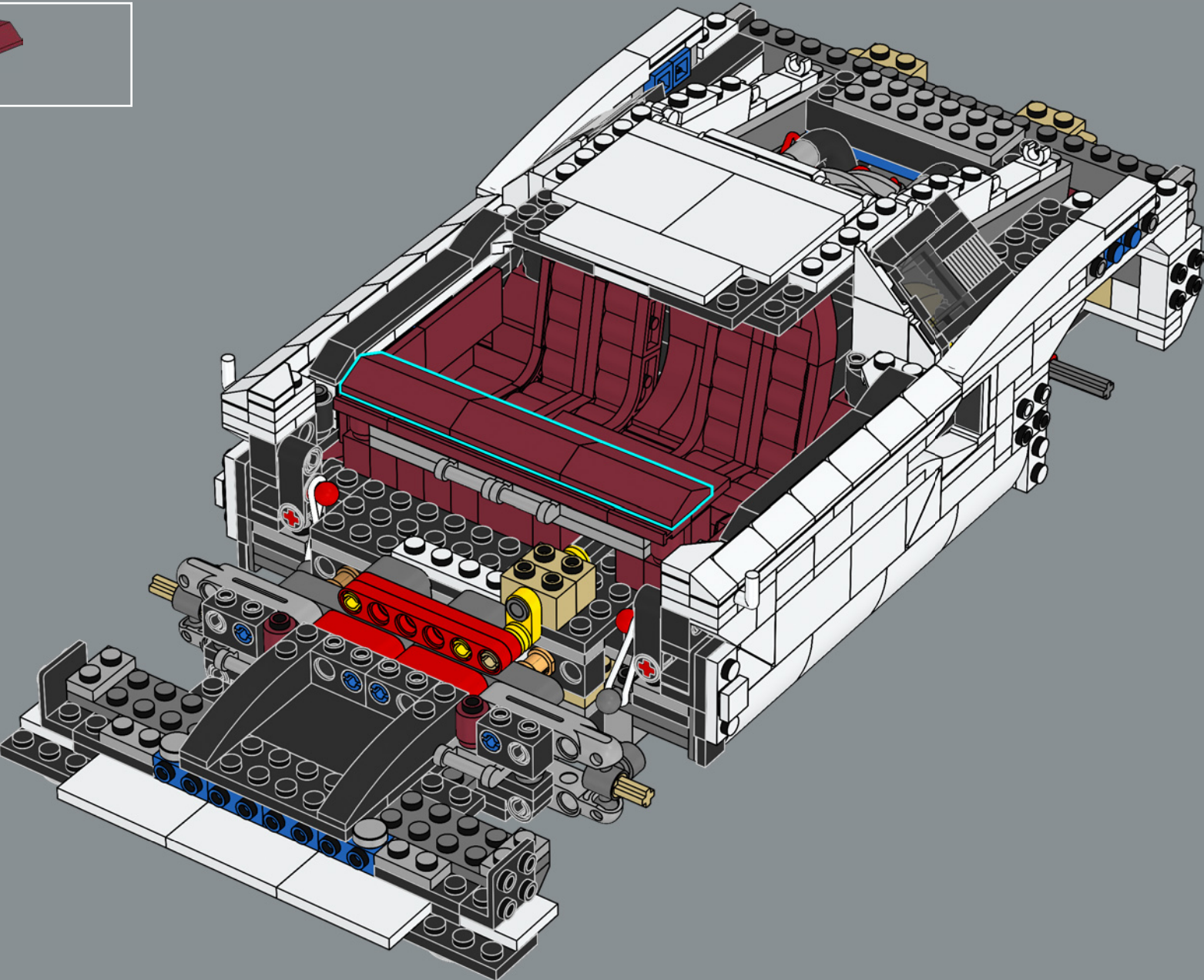

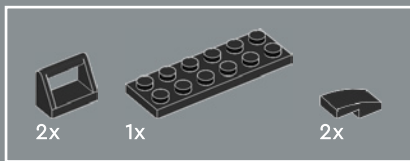

239

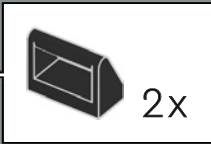
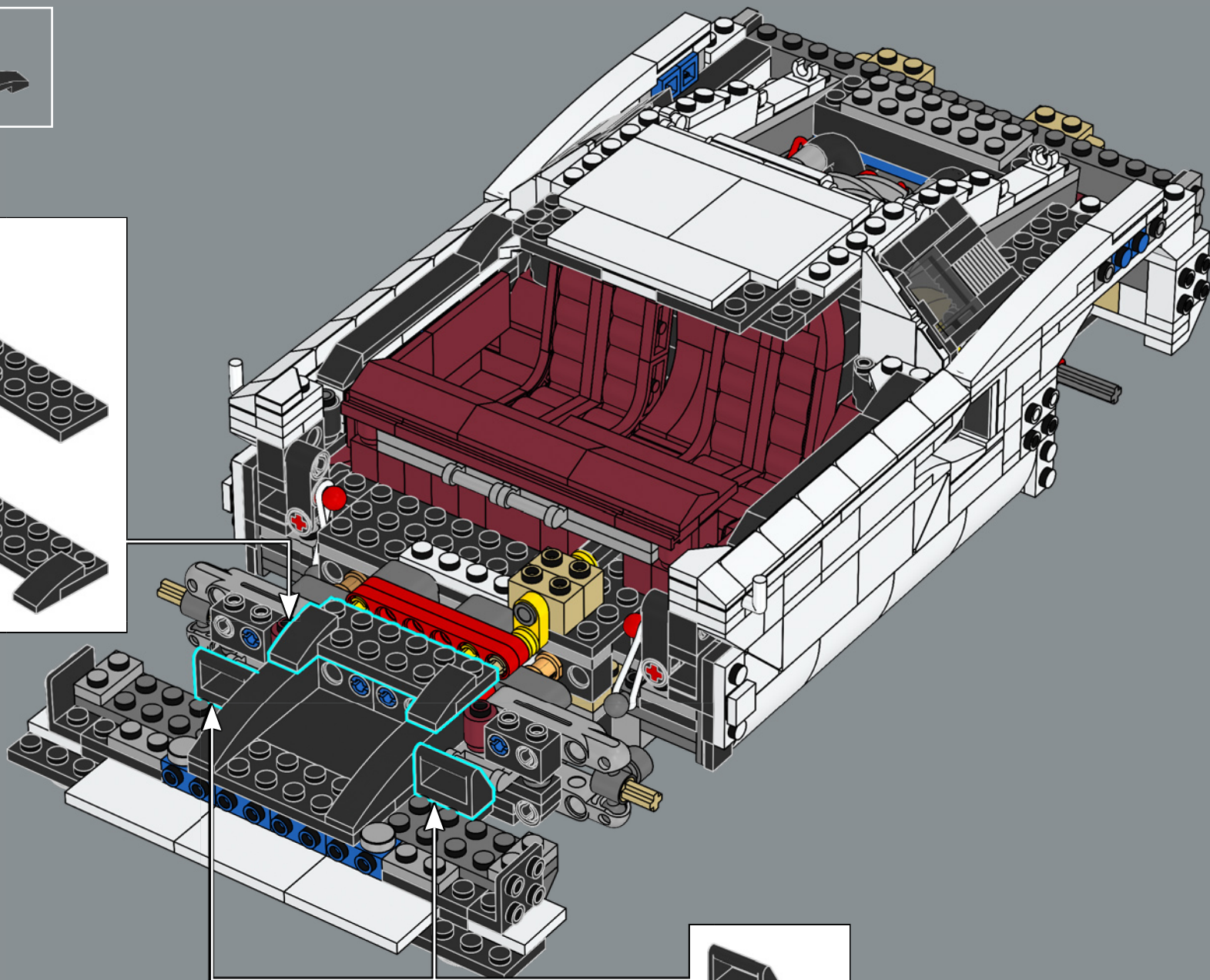
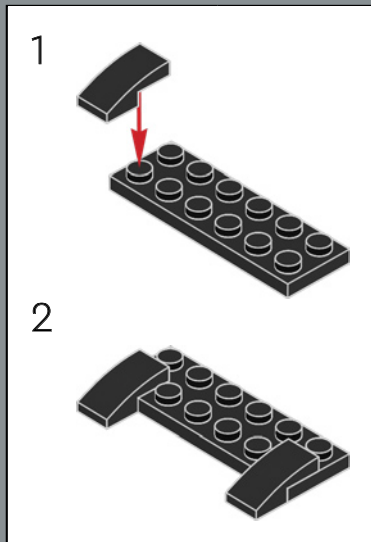



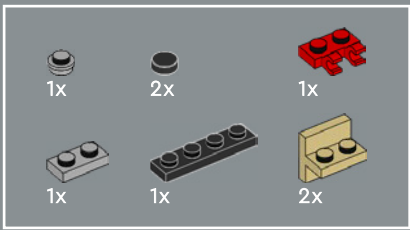

240

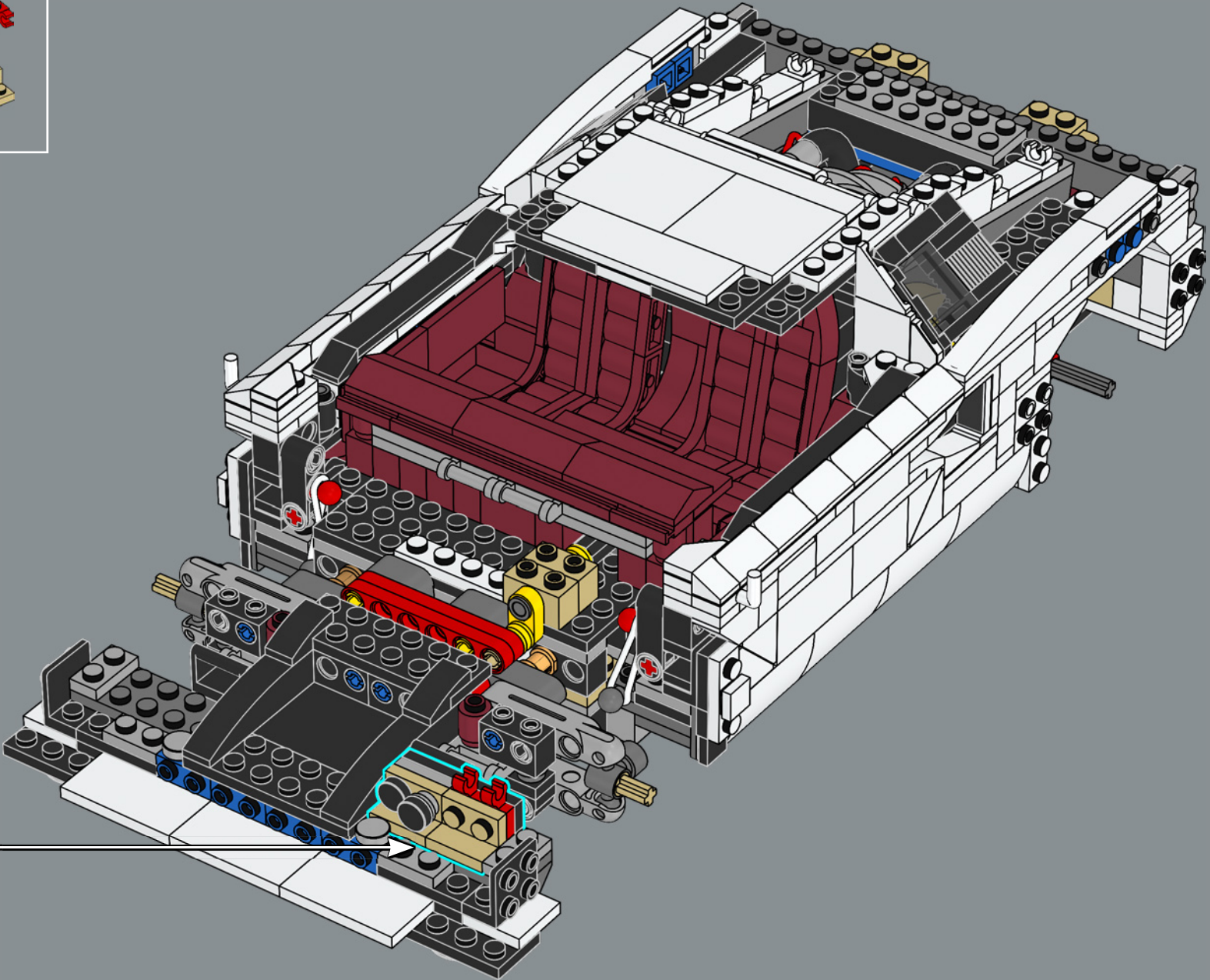
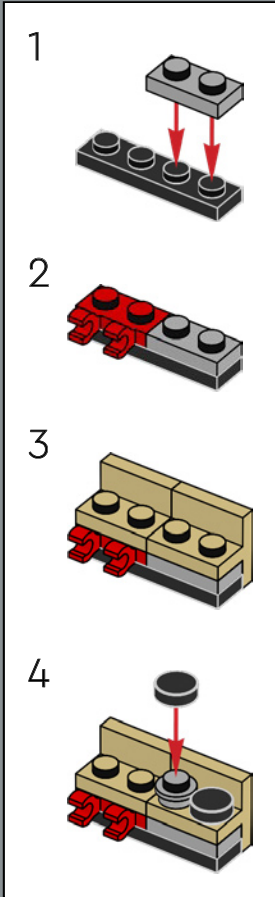

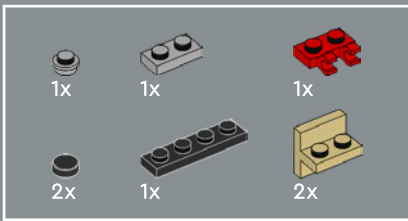

241

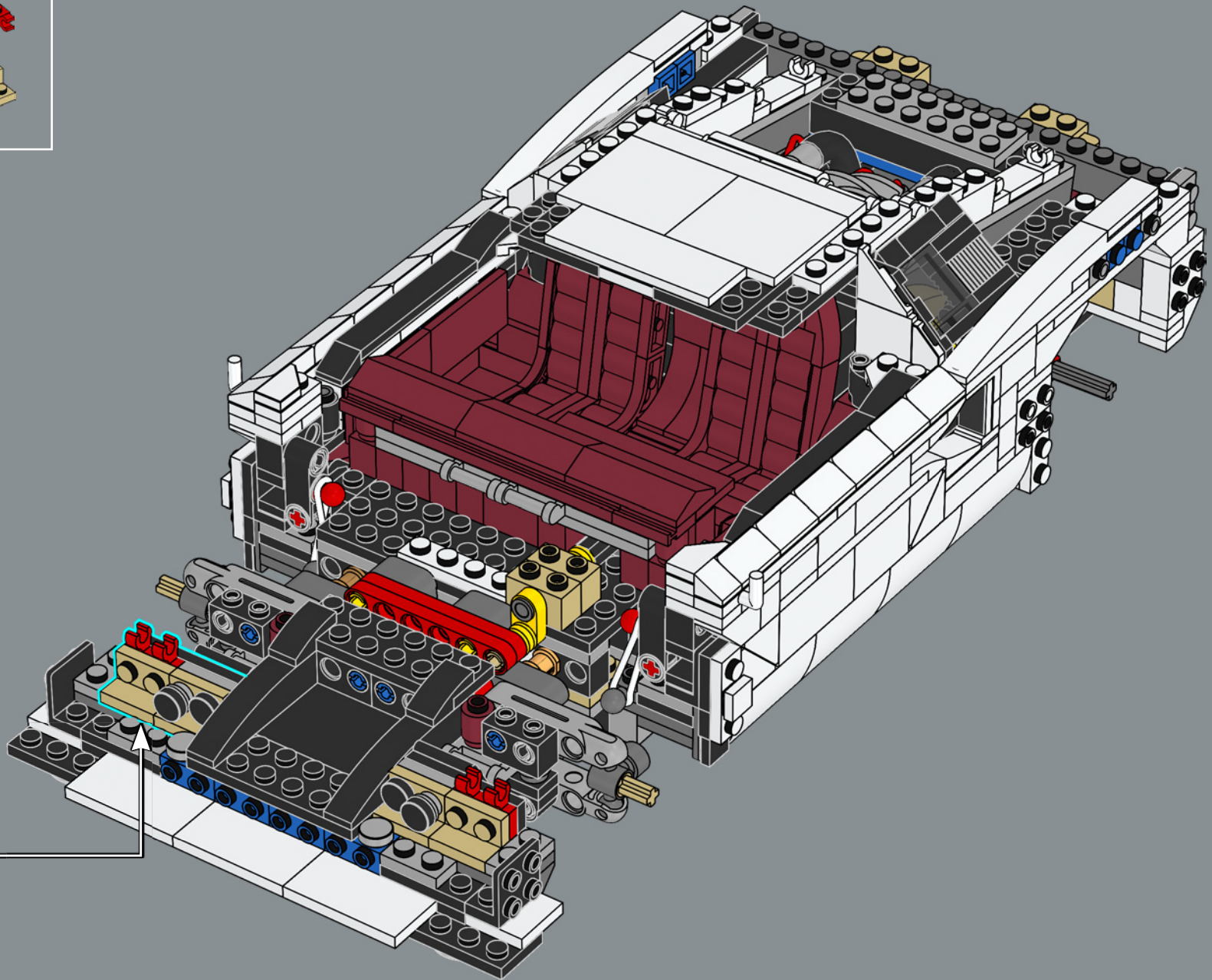
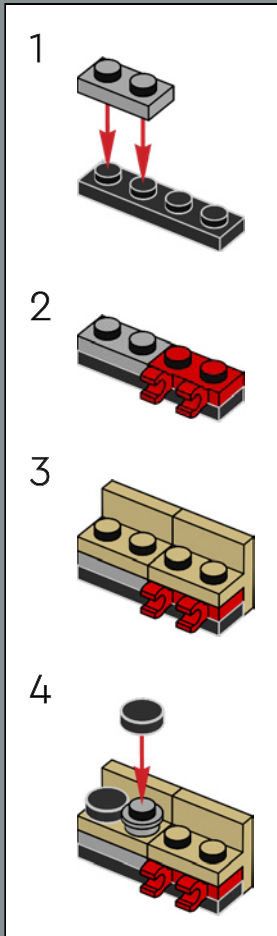





2x

242

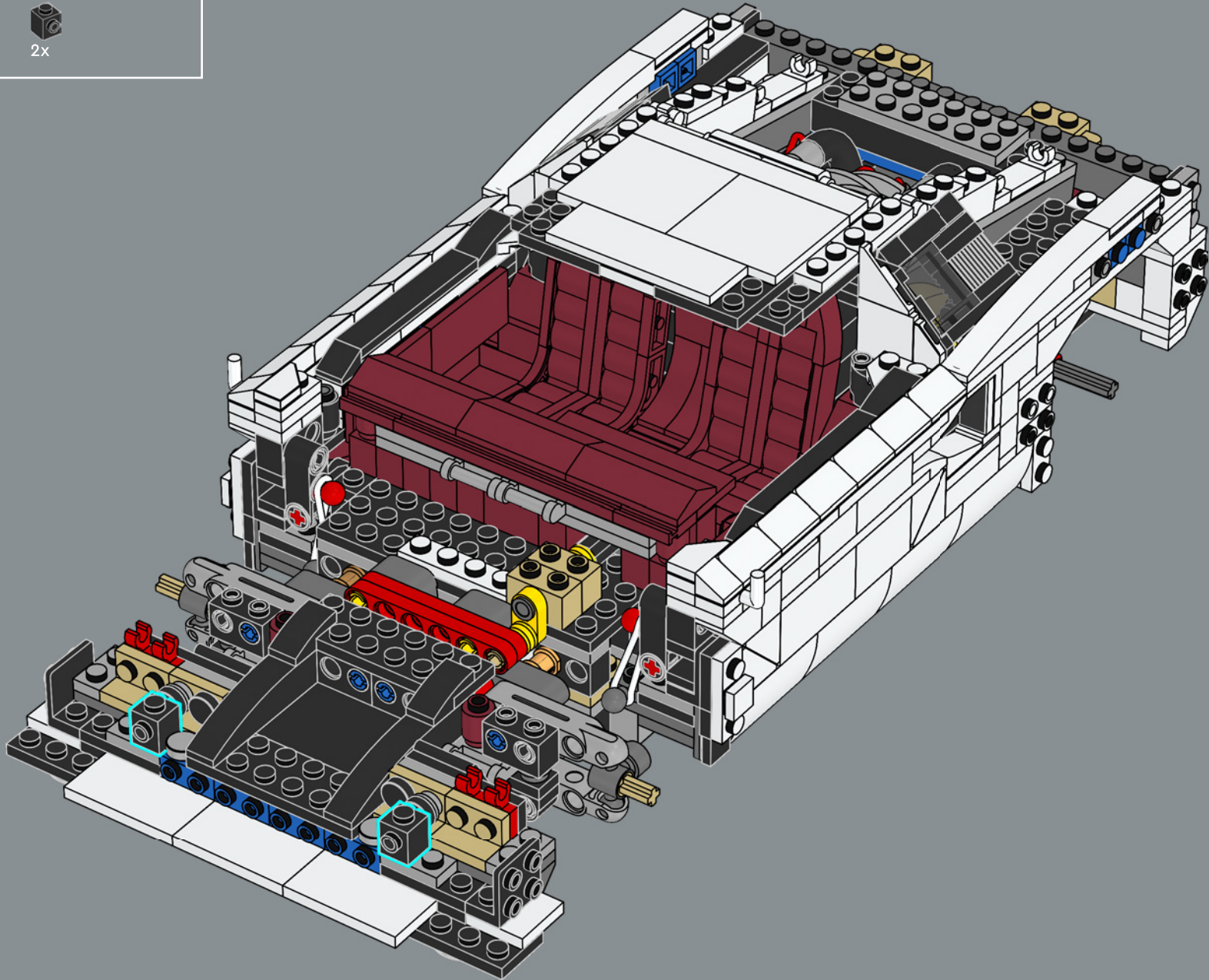

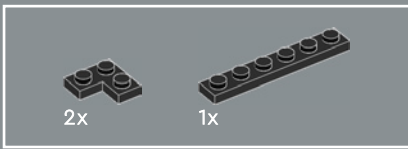

243

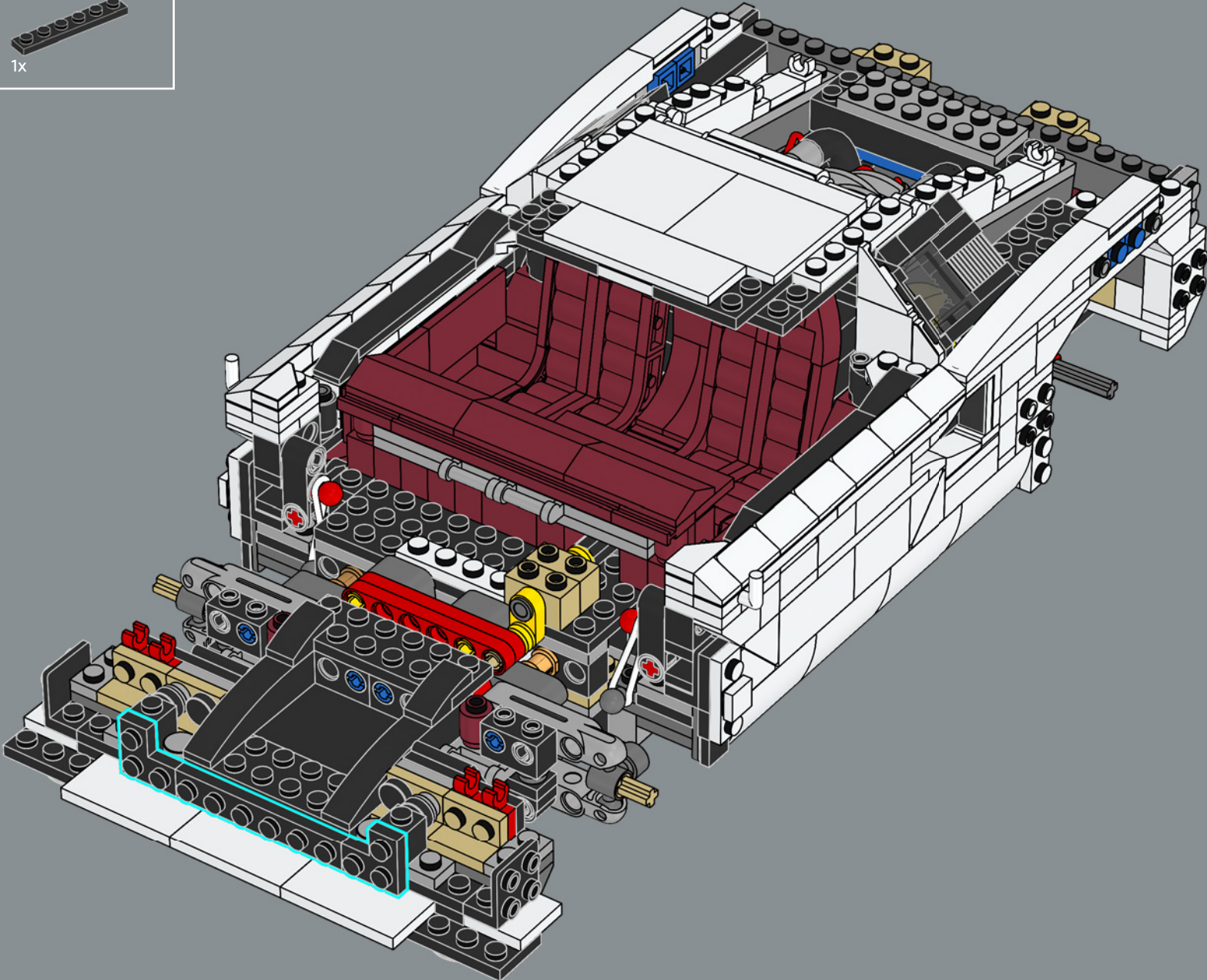





244

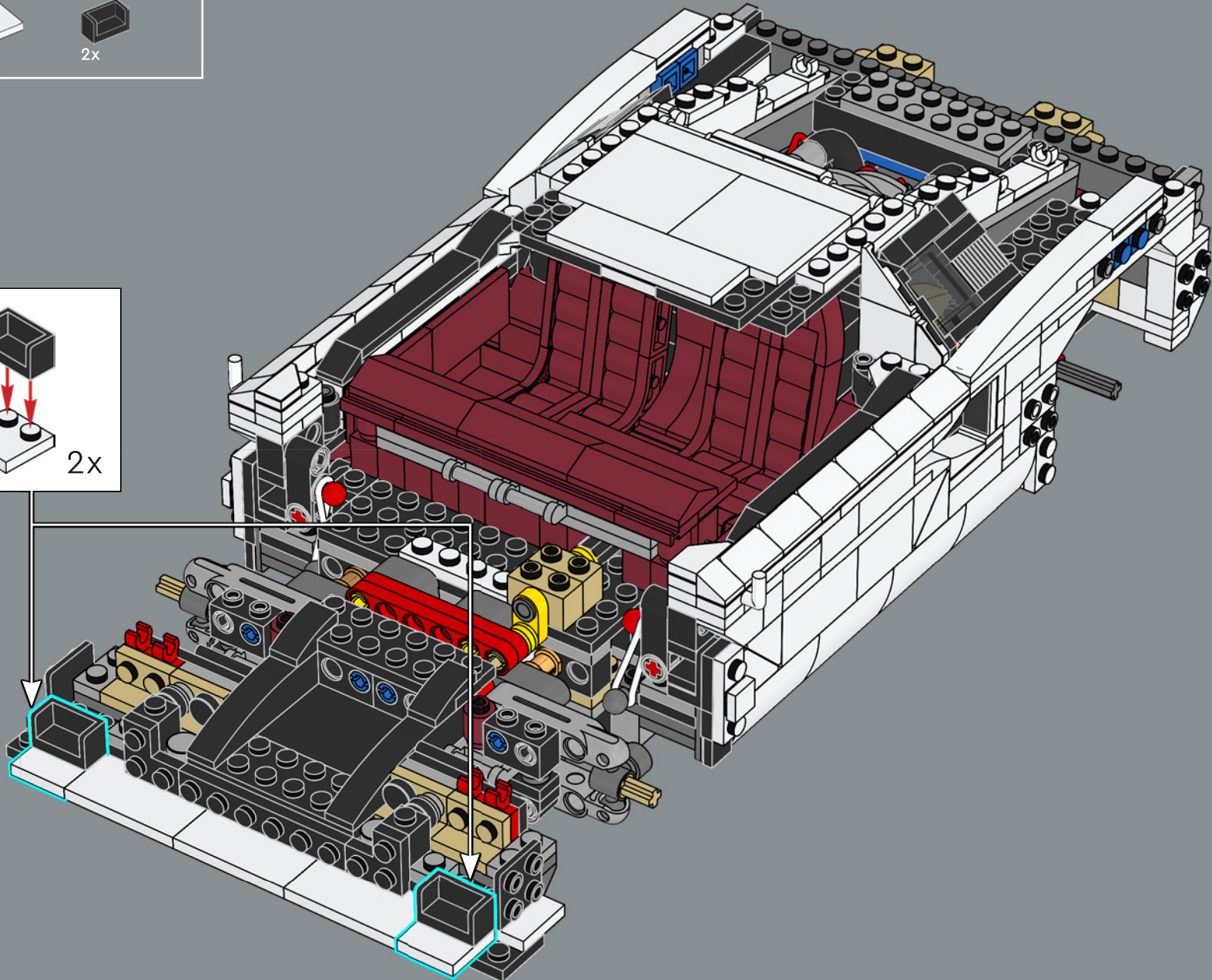
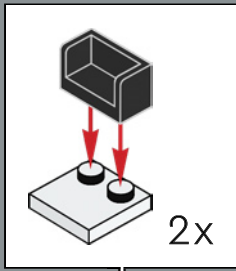

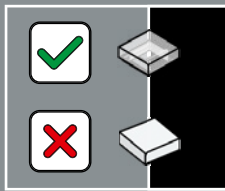
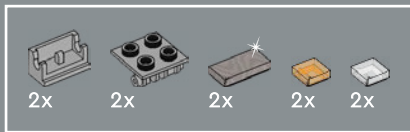

245

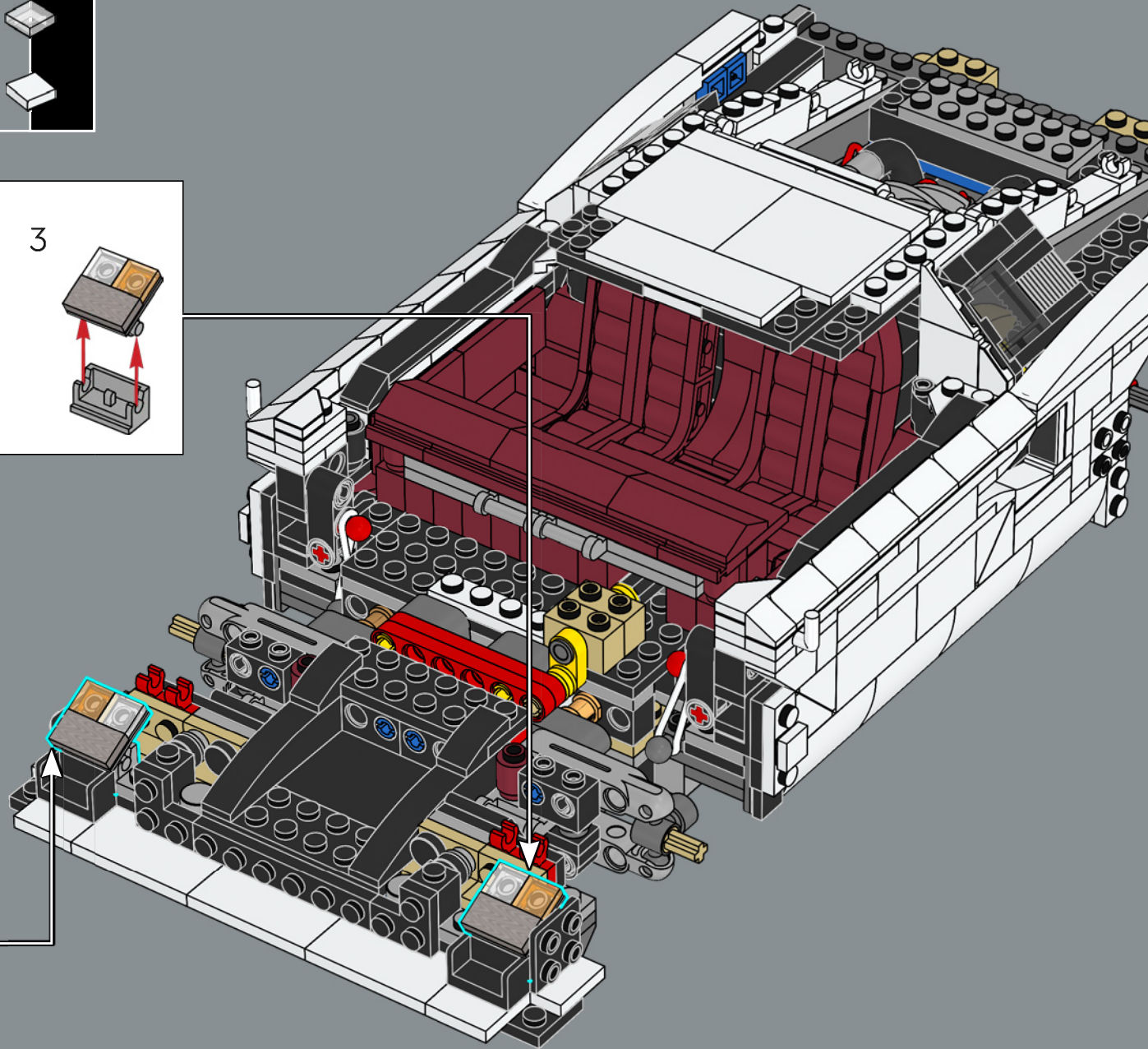
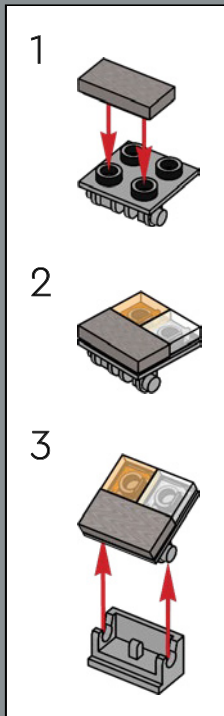
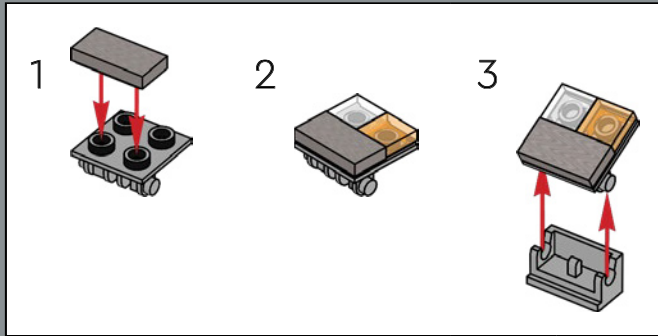



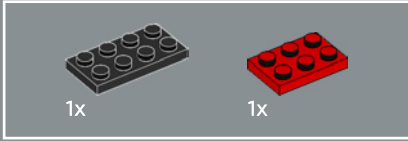
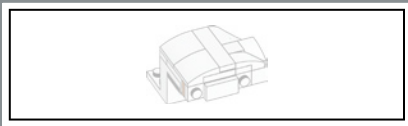

246

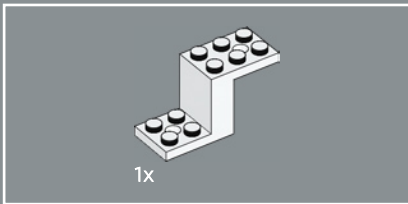
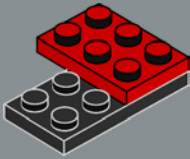

247

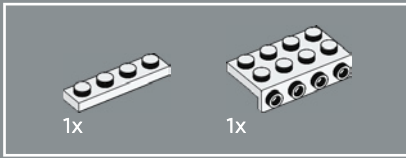
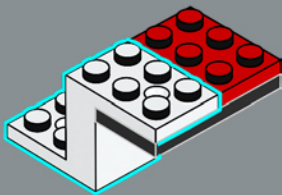

248

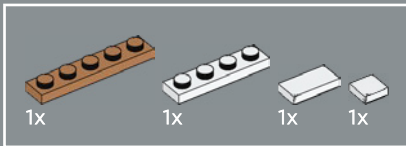
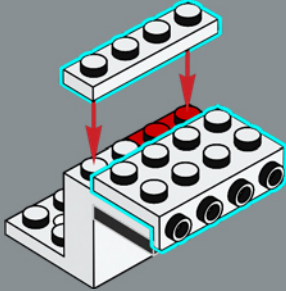

249

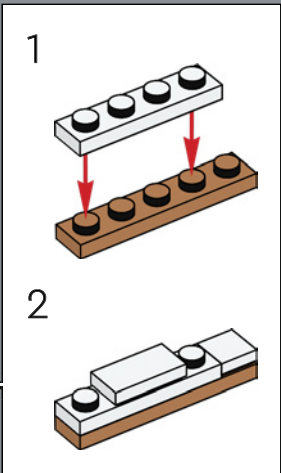
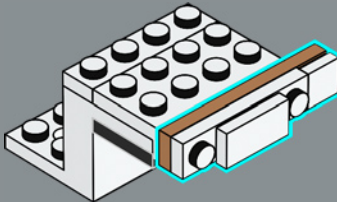

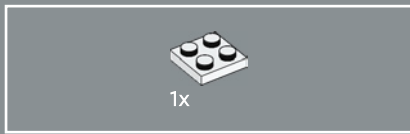

250

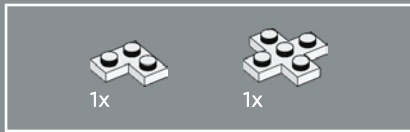
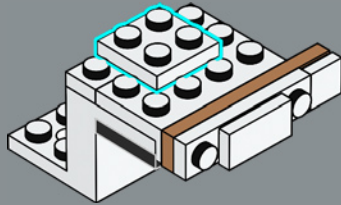

251

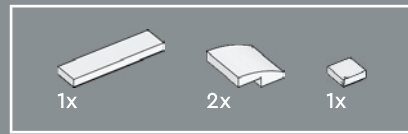
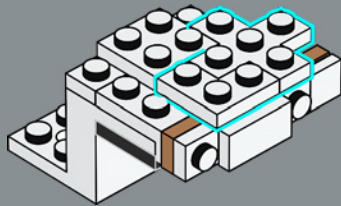

252

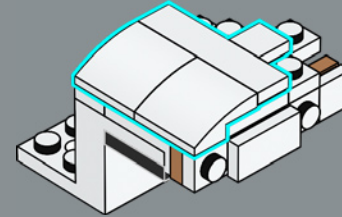

253

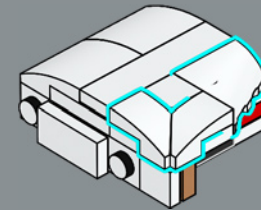

254

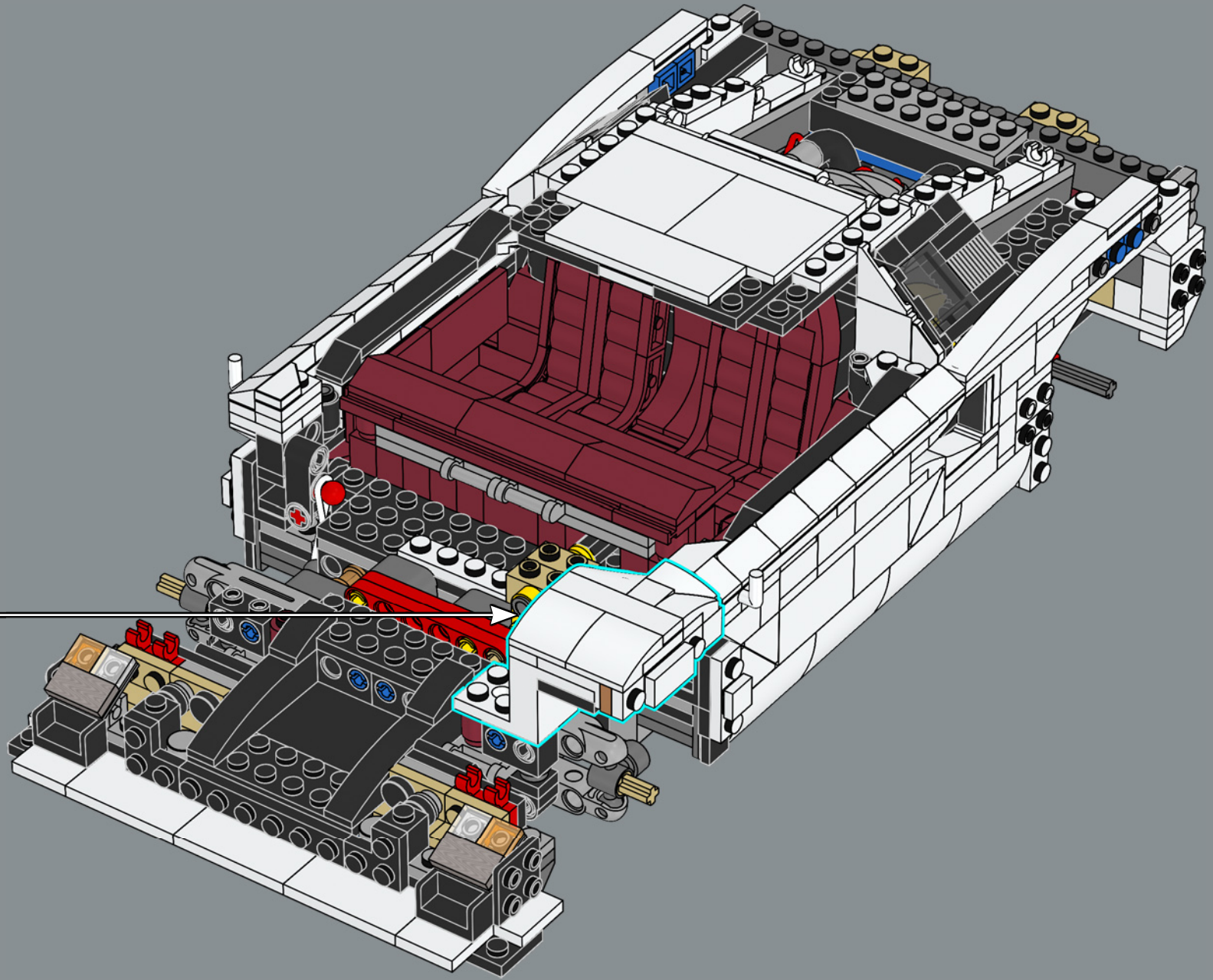



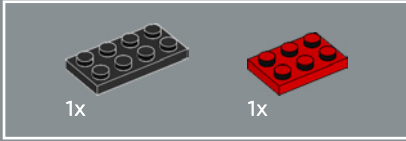
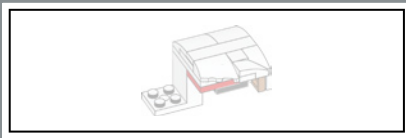

255

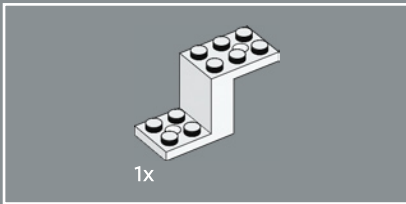
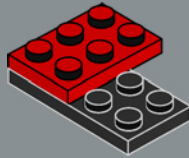

256

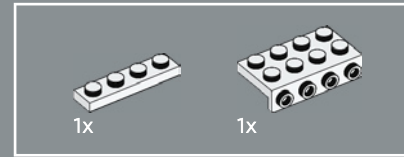
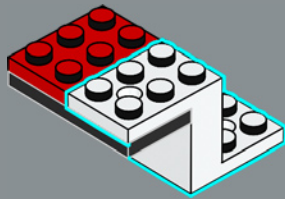

257

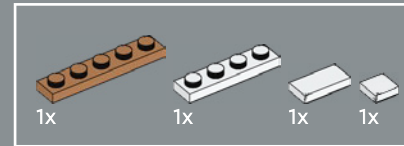
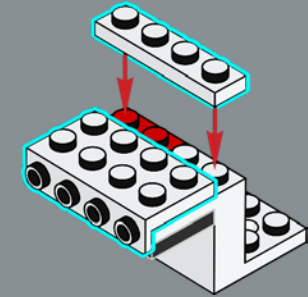

258

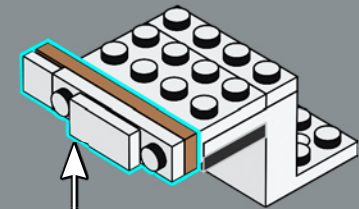
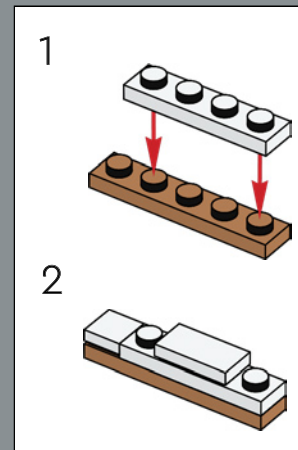

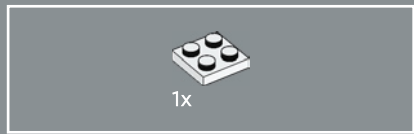

259

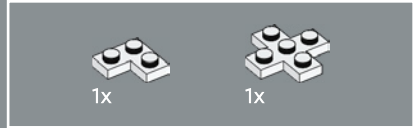
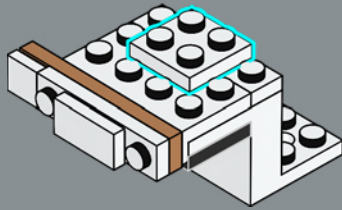

260

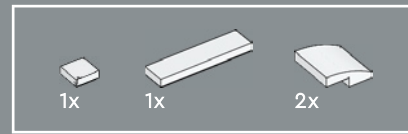
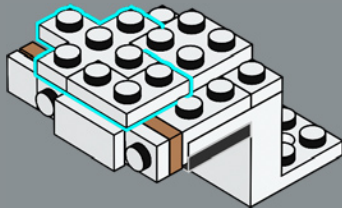

261

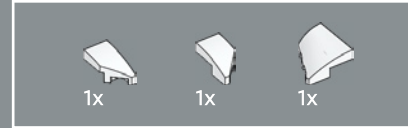
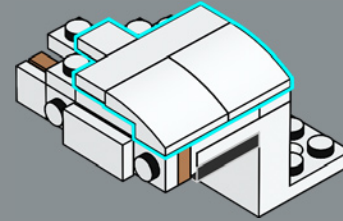

262

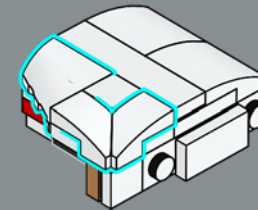

263

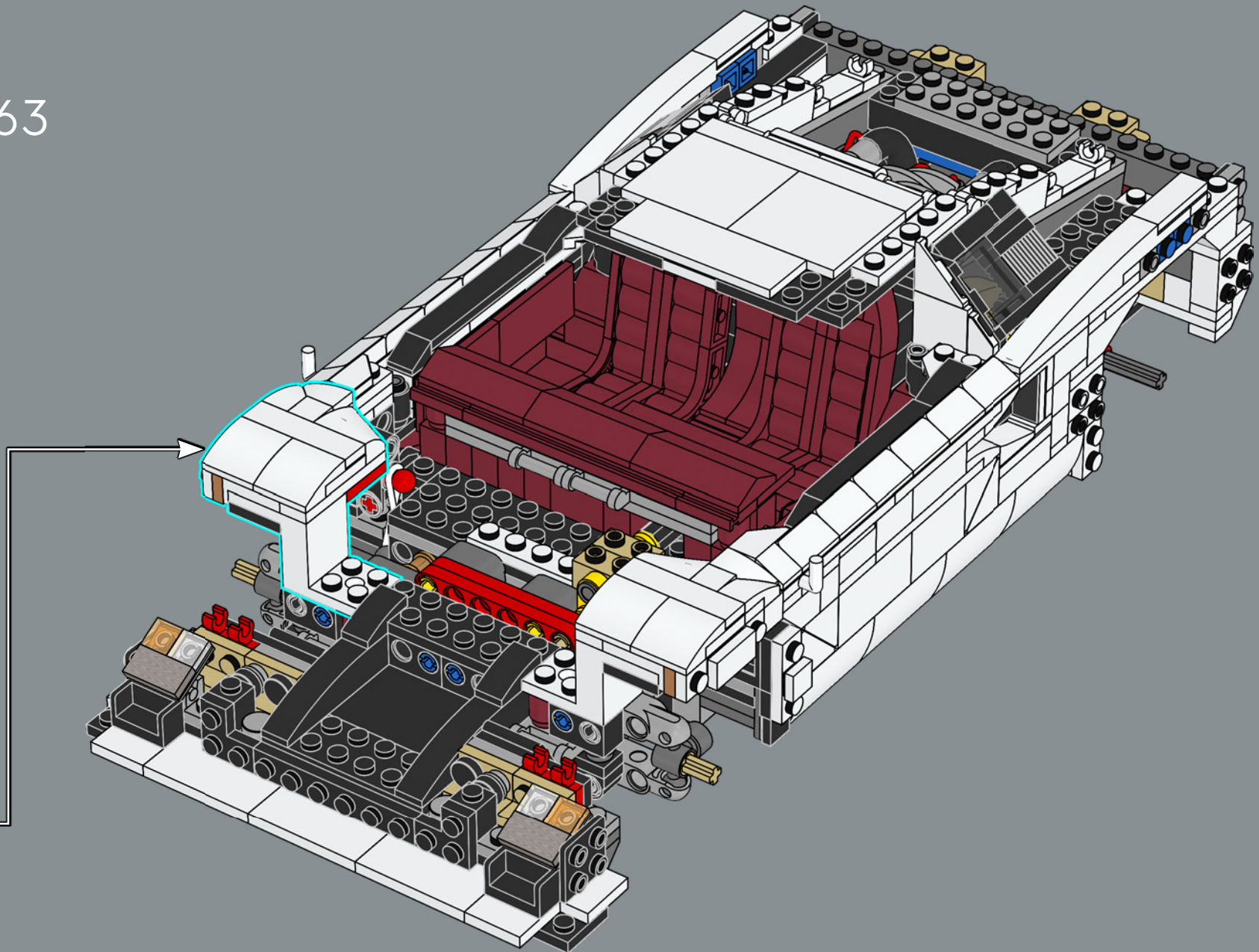



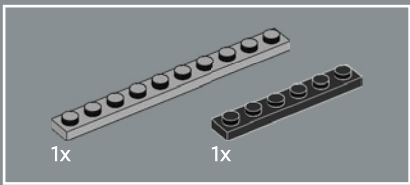

264

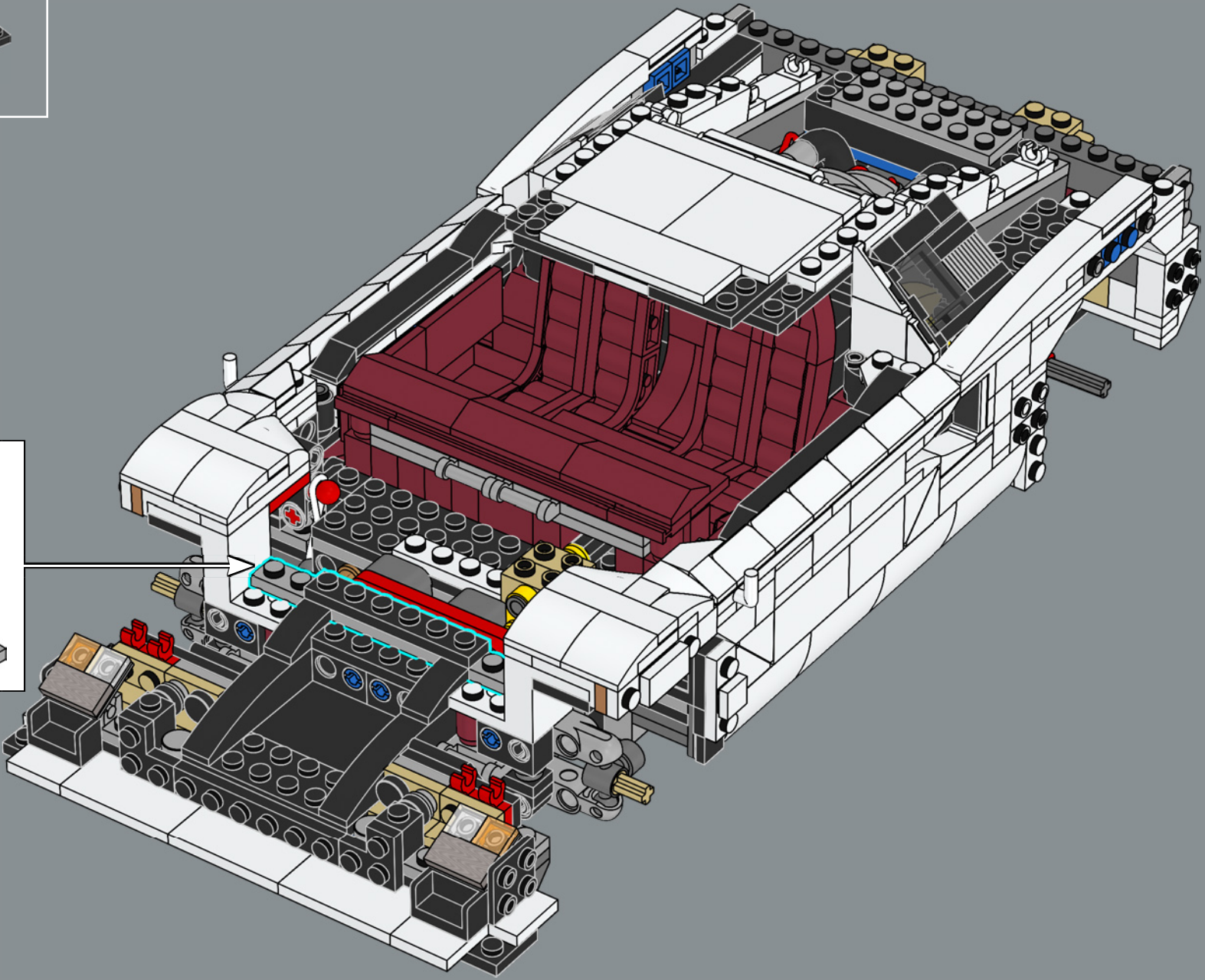
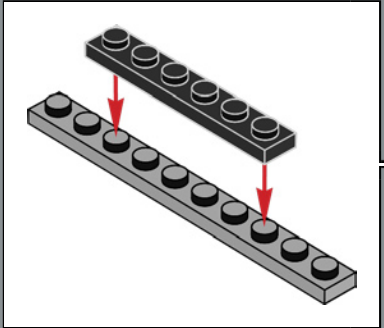

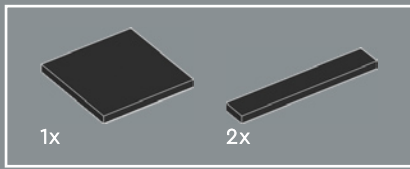

265

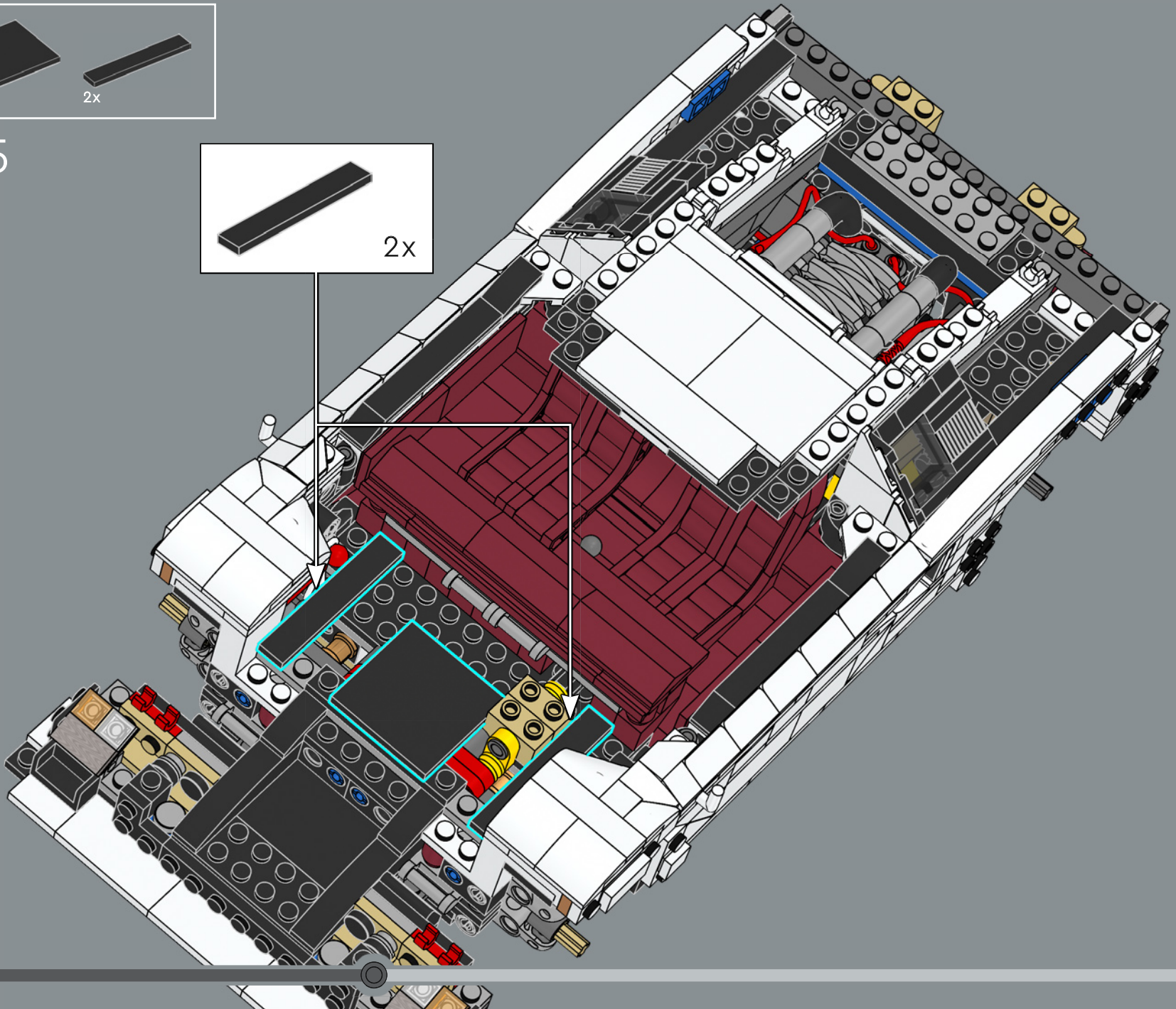
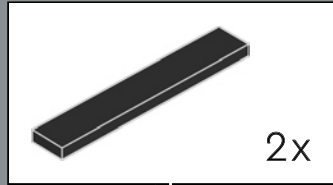



-  2x
-  2x
-  6x
-  2x

266

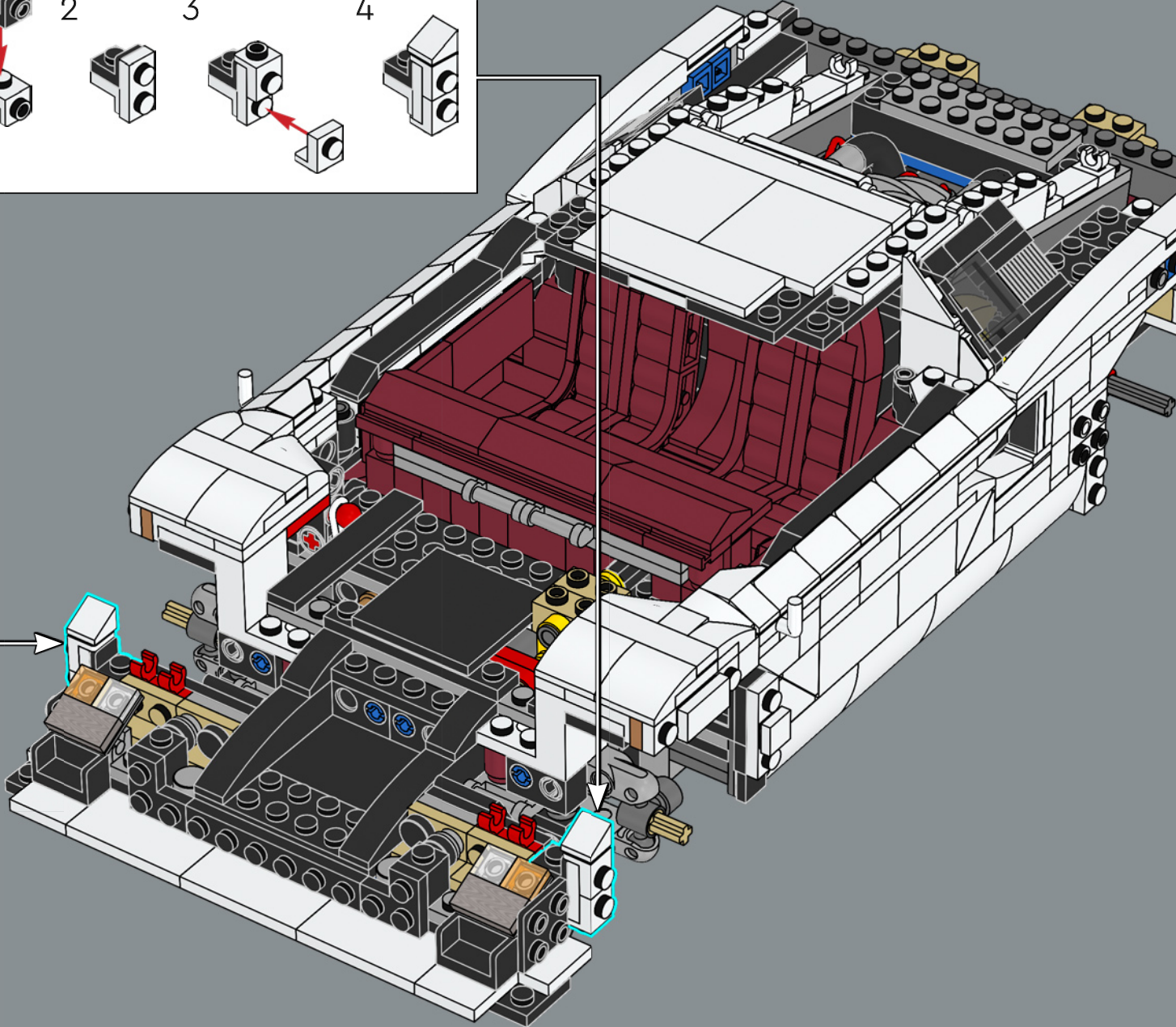
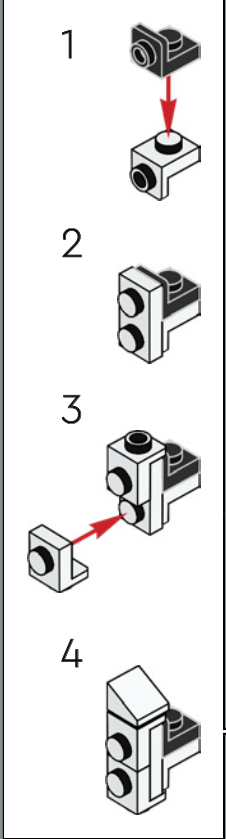
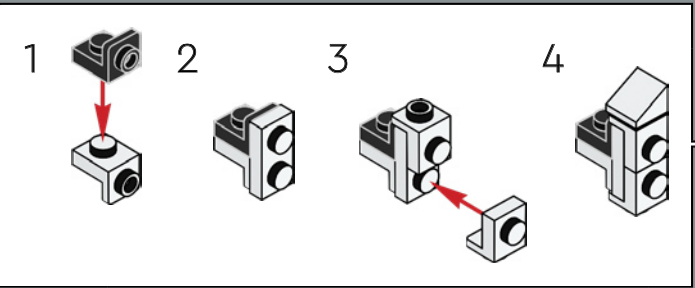





2x

267



2x

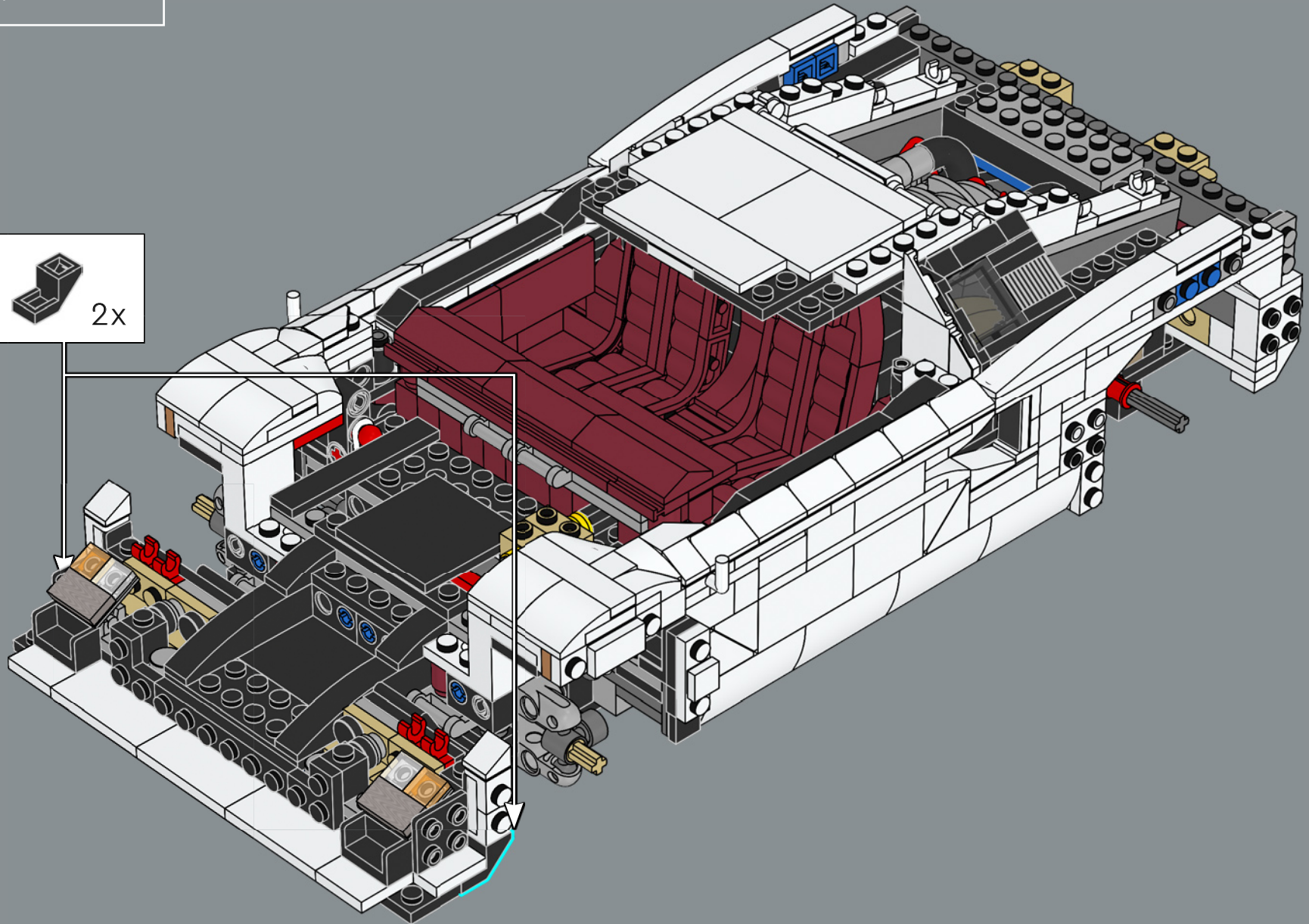

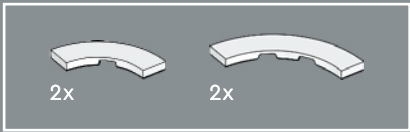

268

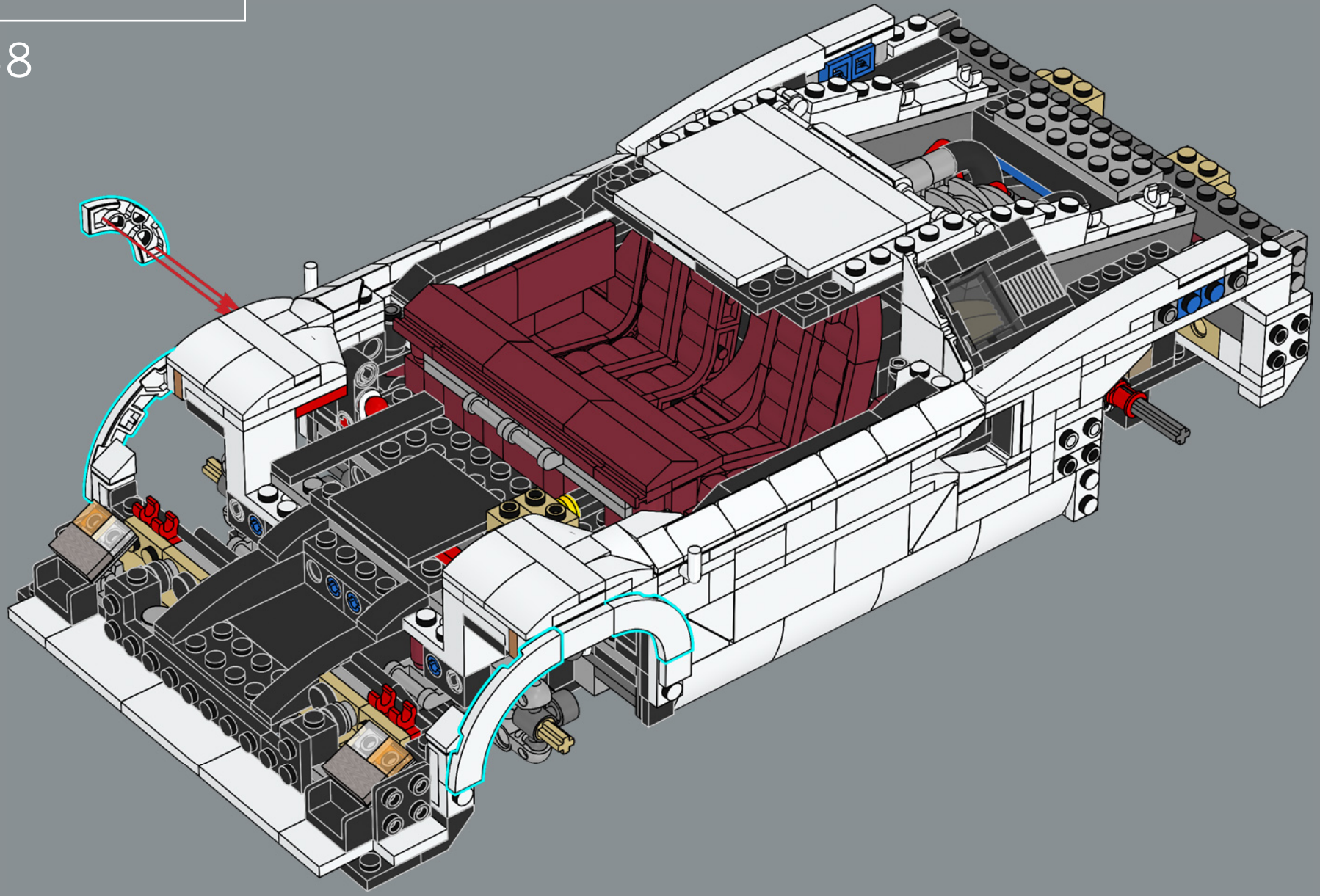

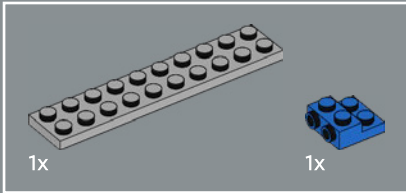
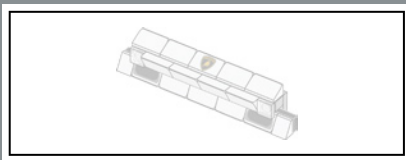

269

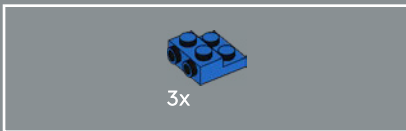
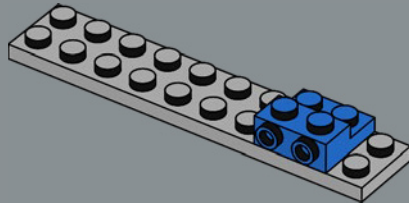

270

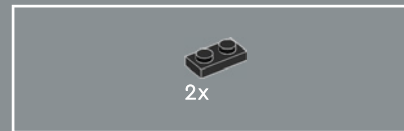
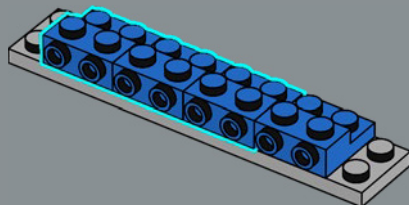

271

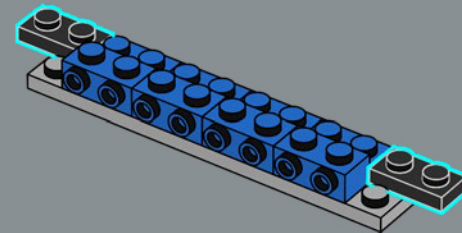

272

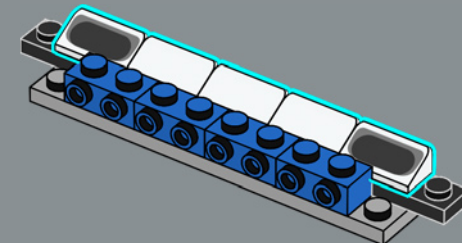





2x

273

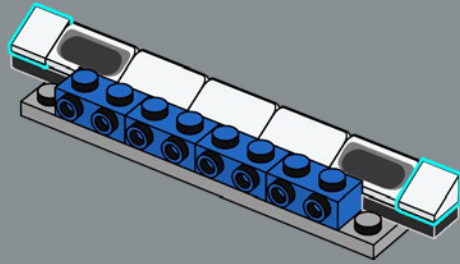

4x

274

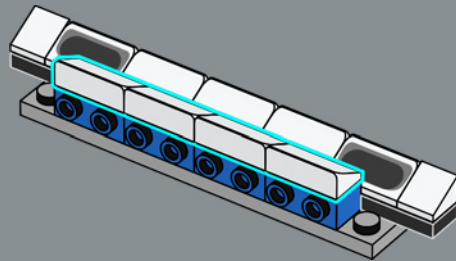

2x



2x

275

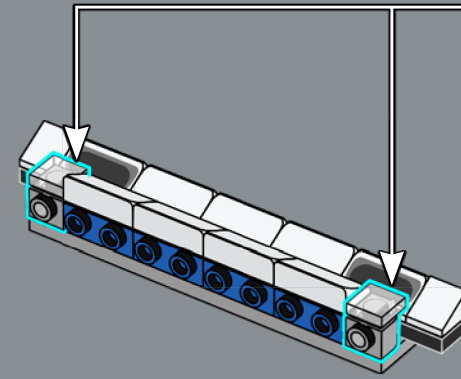

2x



4x



1x

276

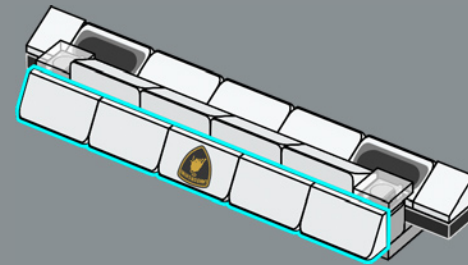

277

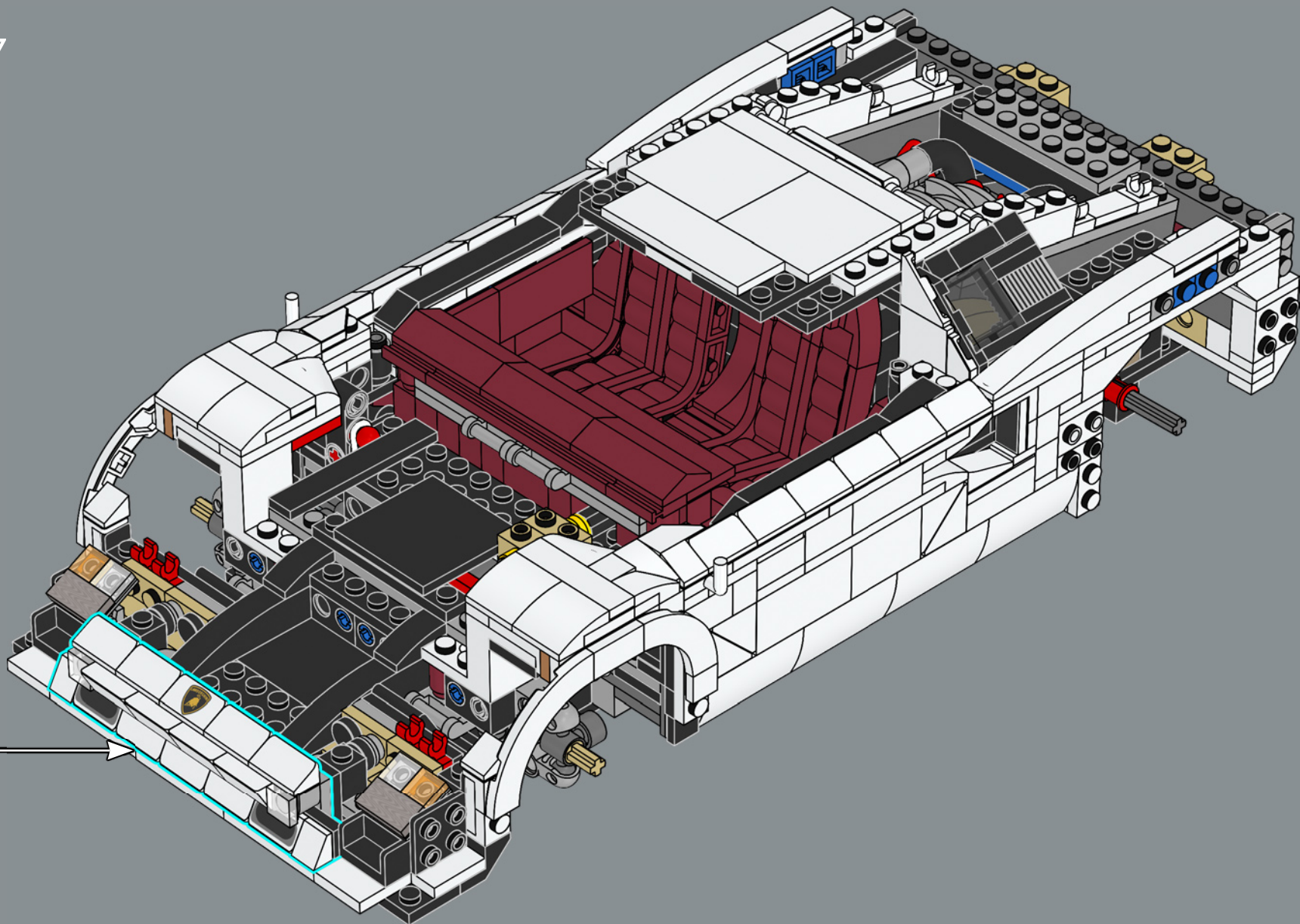

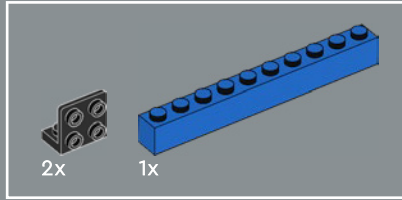
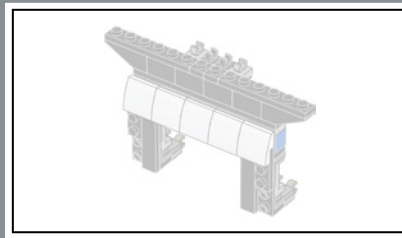
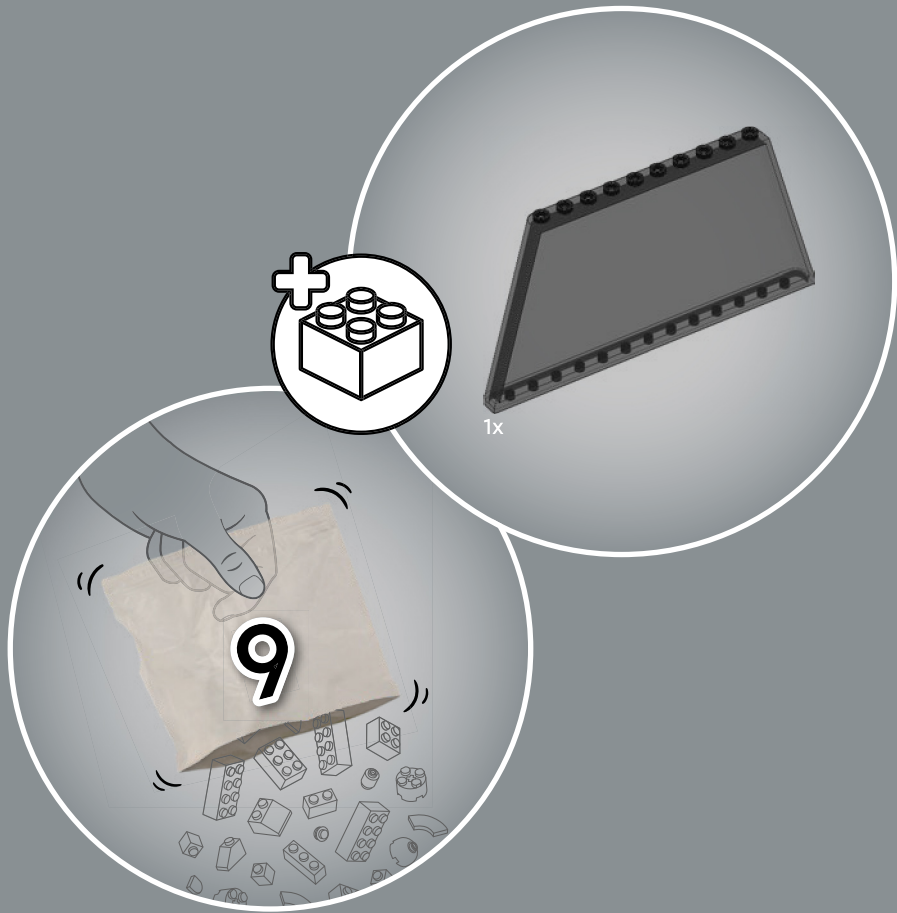

278

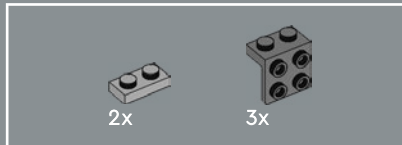
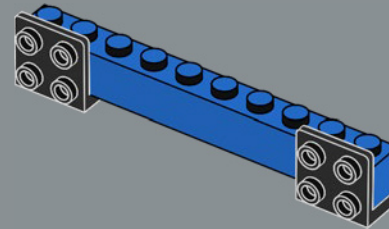

279

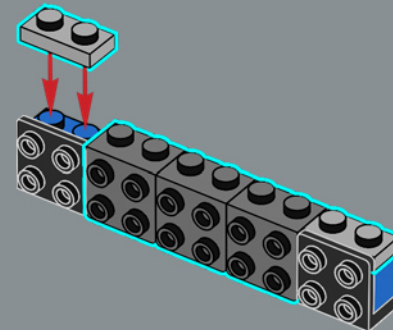



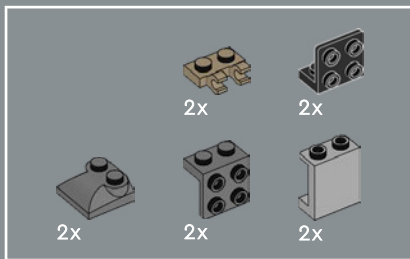

280

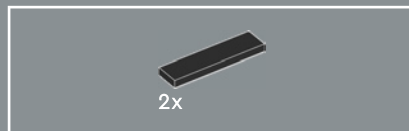
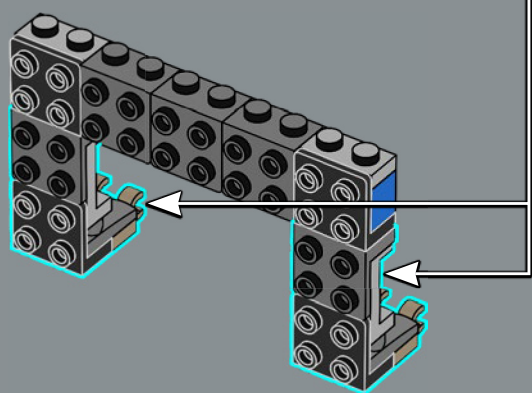
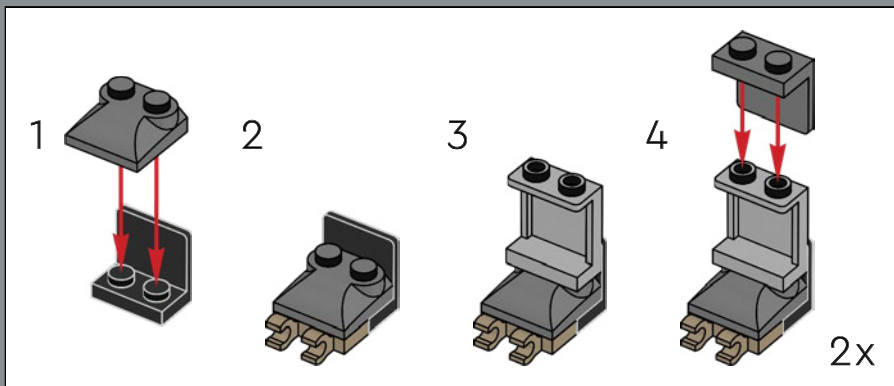

281

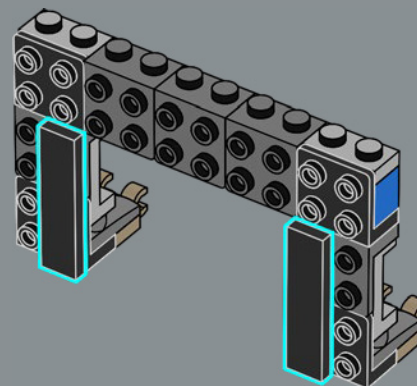

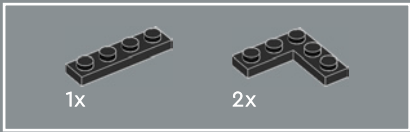

282

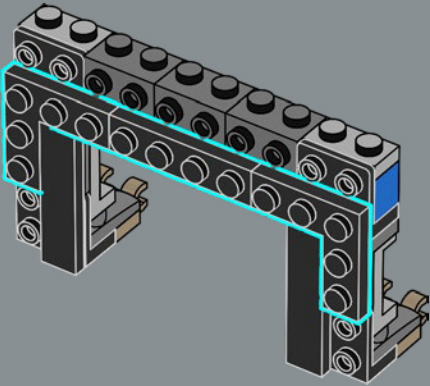

283

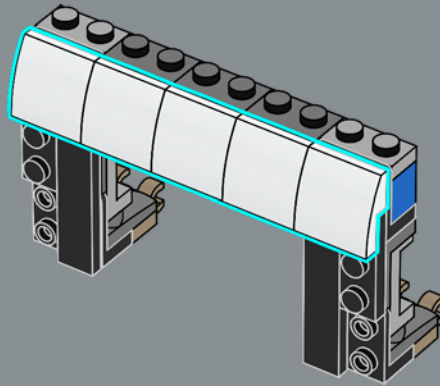

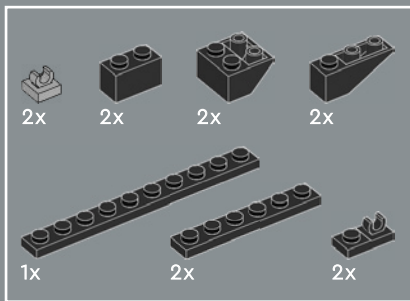

284

1

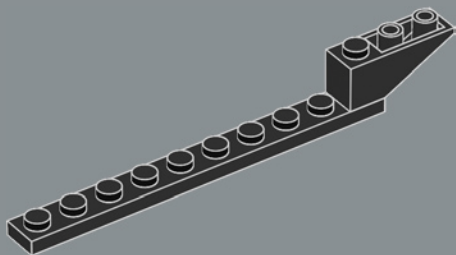

2

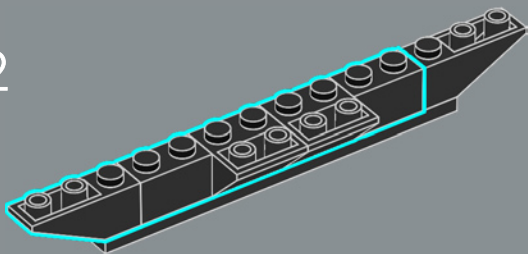

3

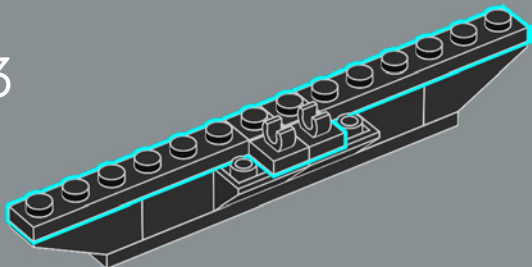

4

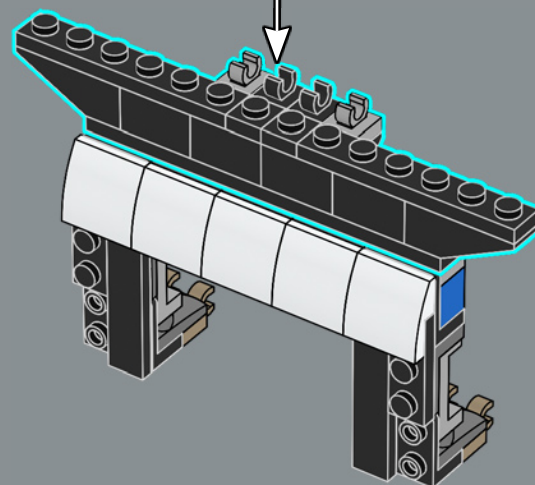
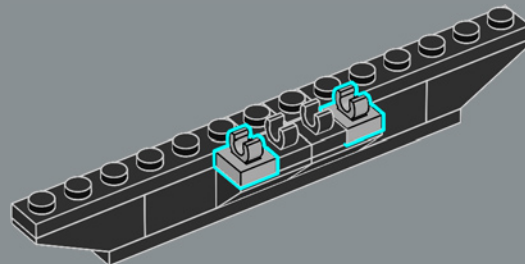



285

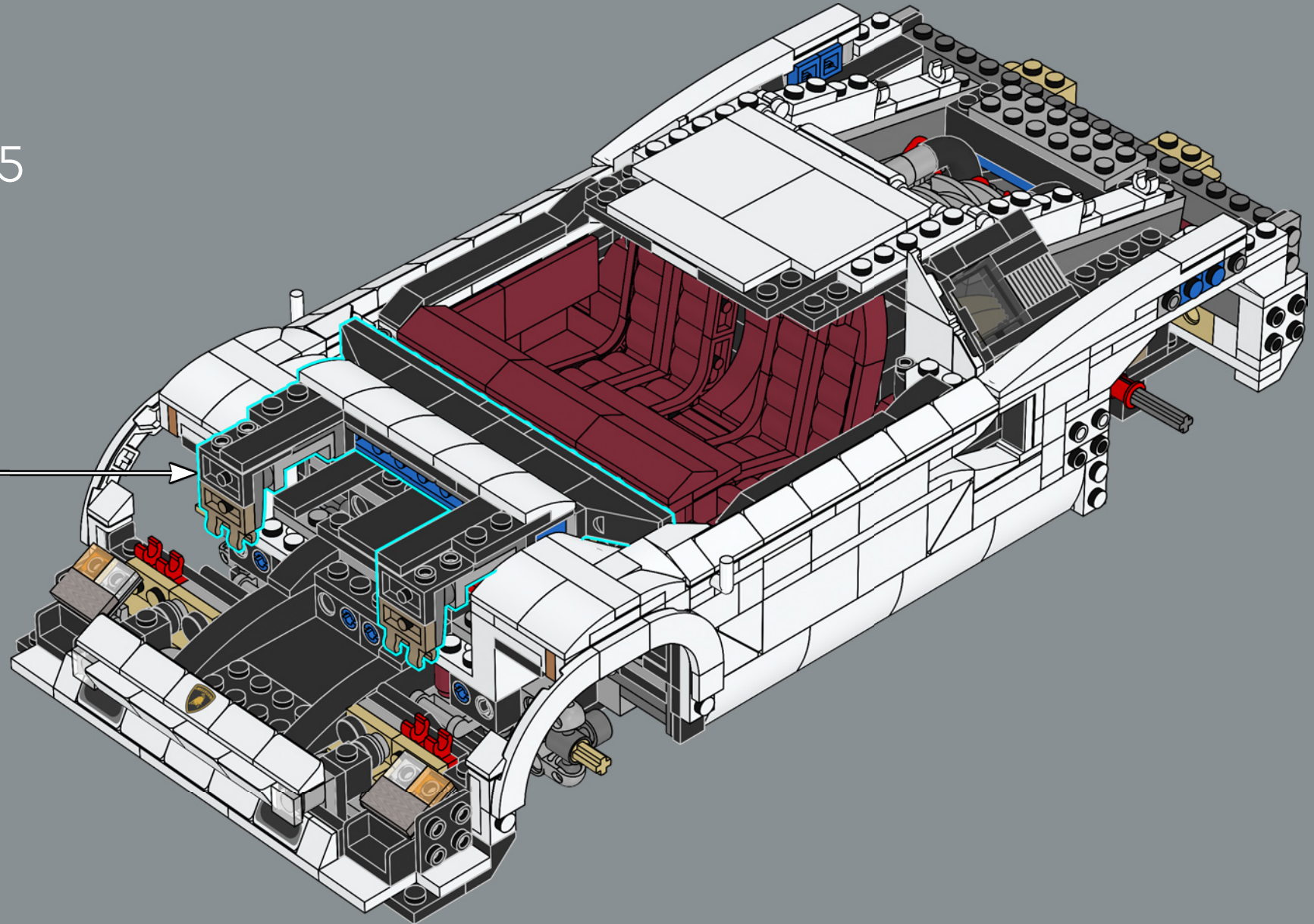

286

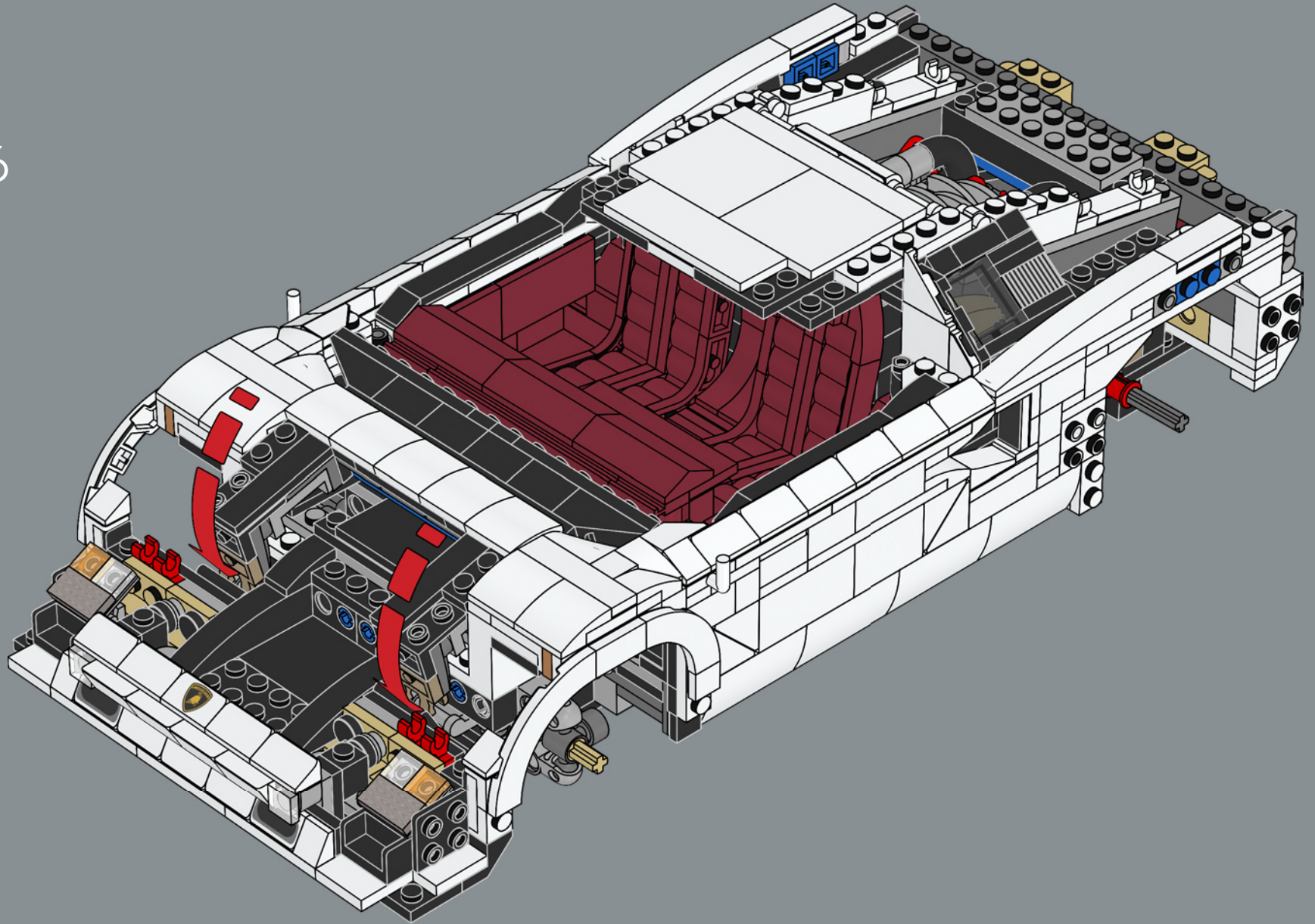





287

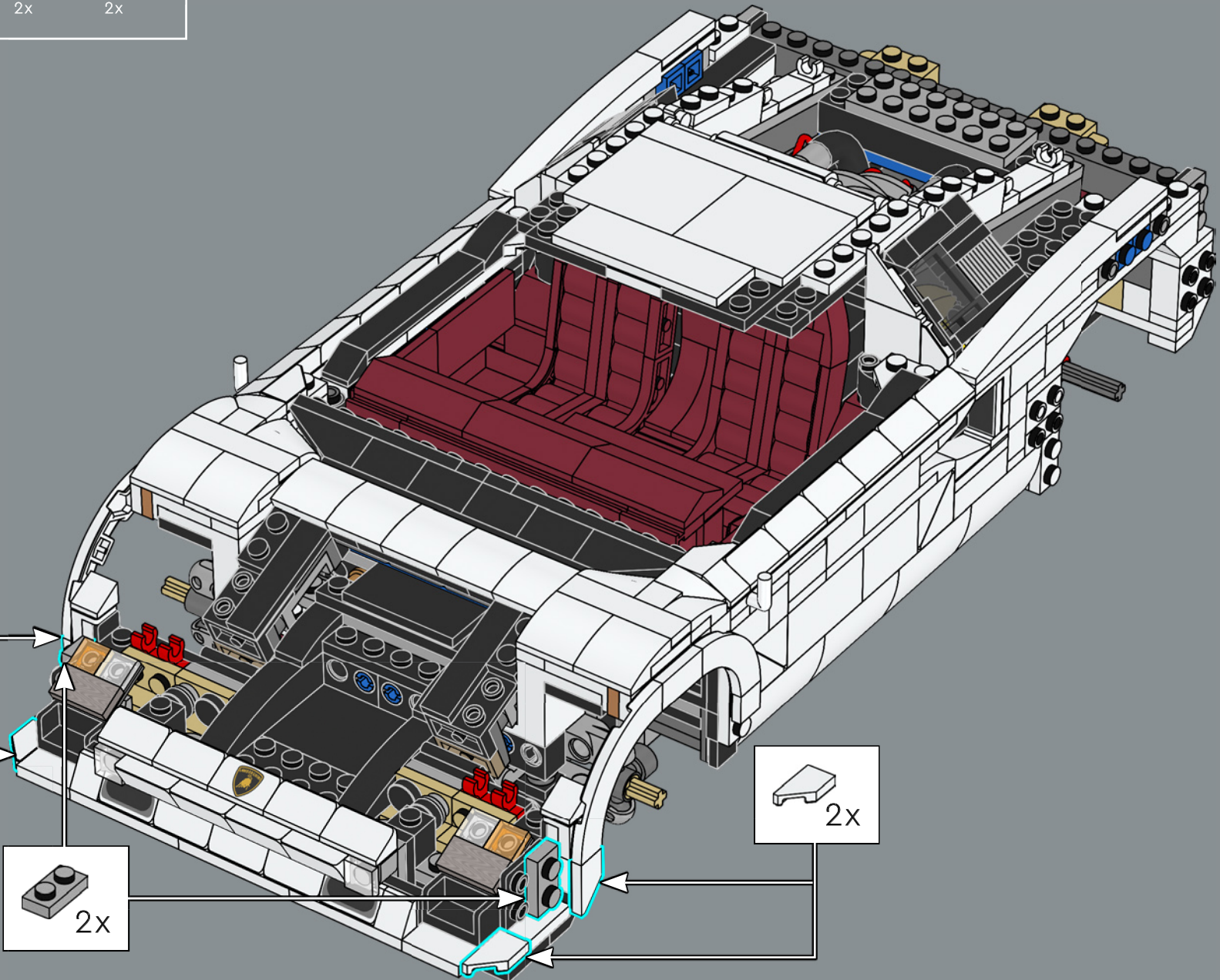
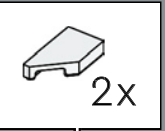
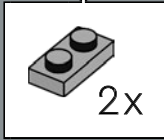
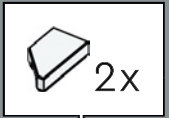





2x

288

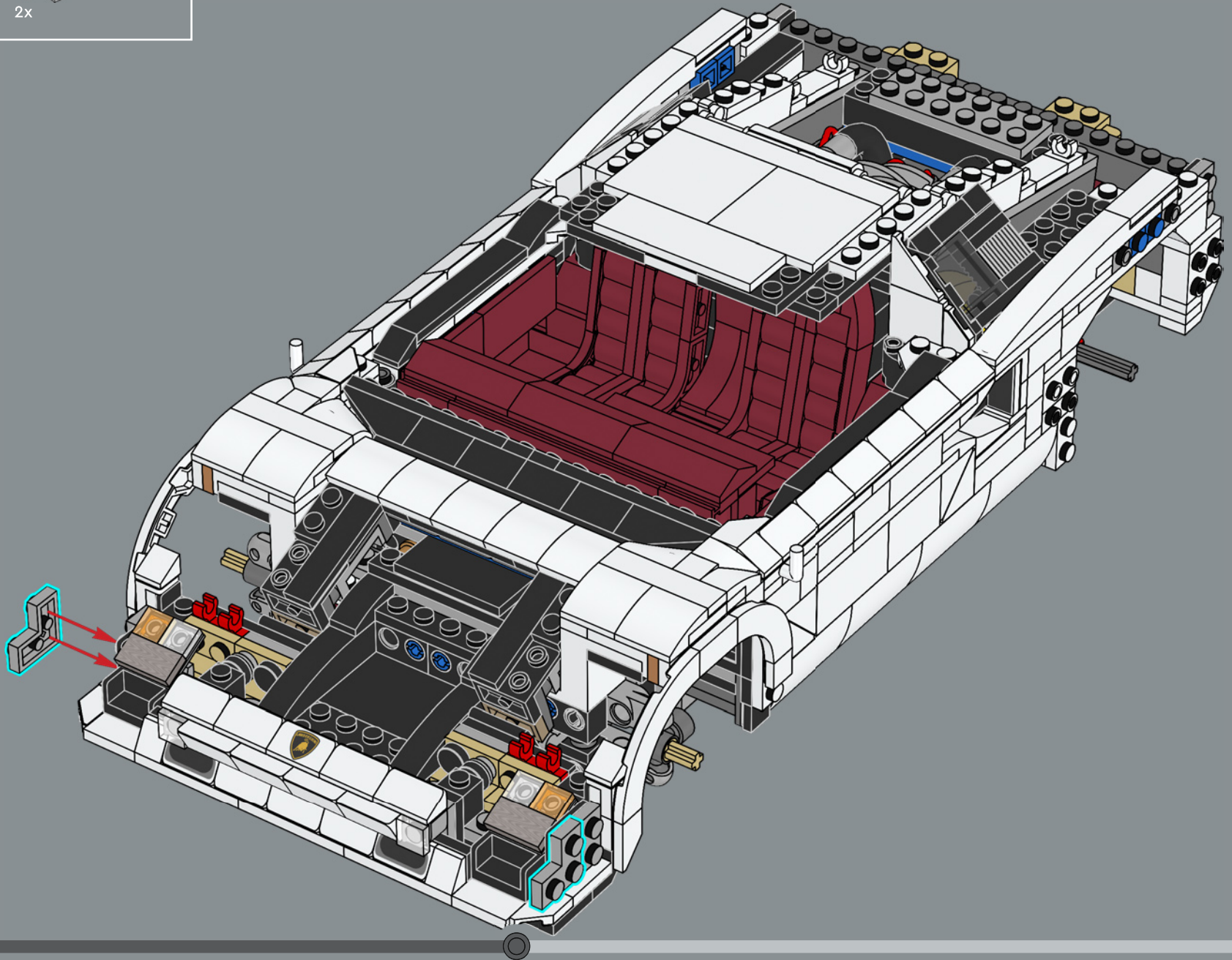

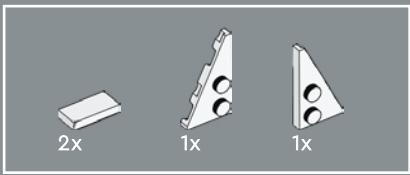

289

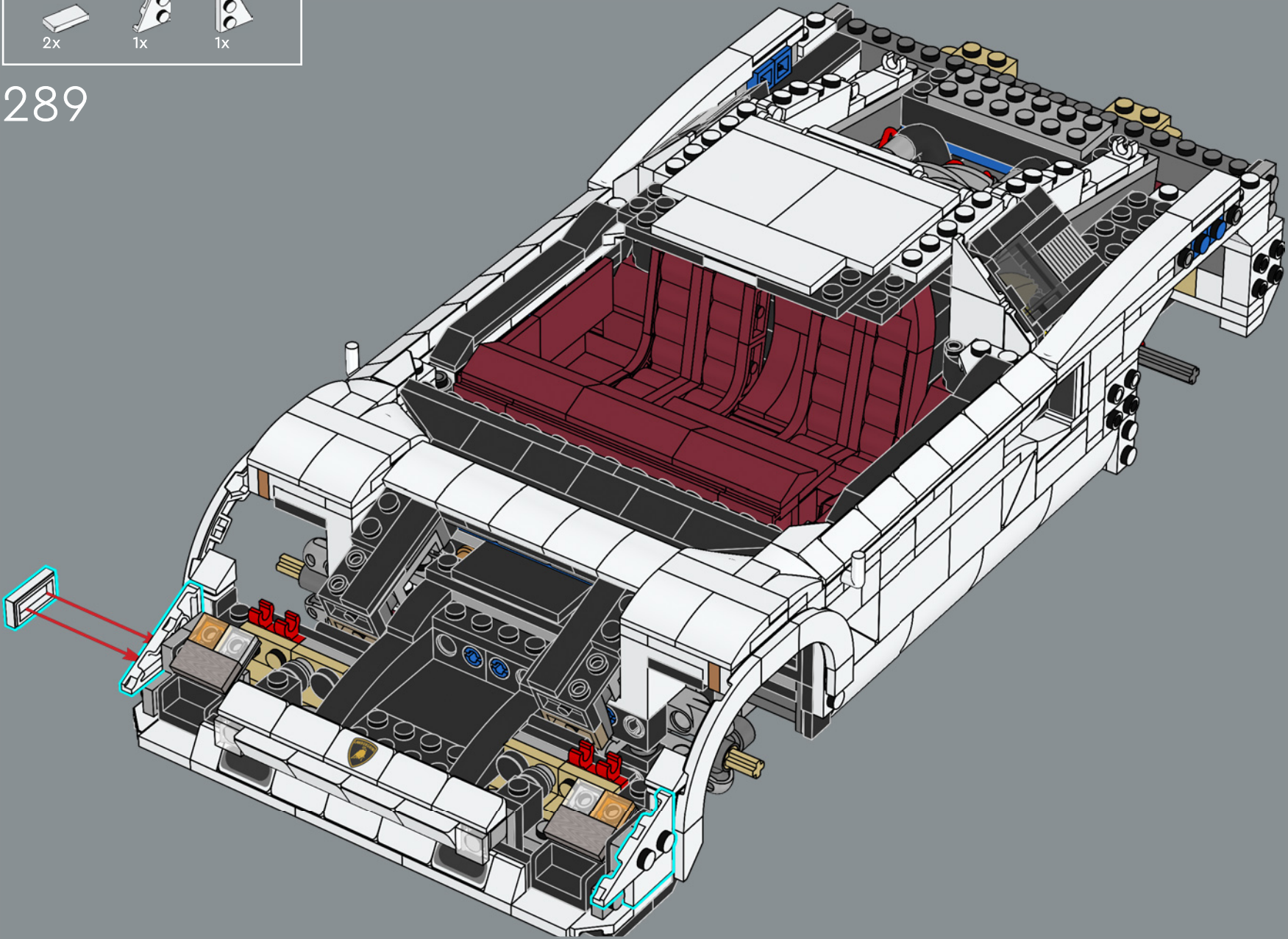



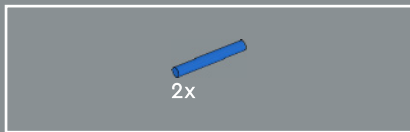

290

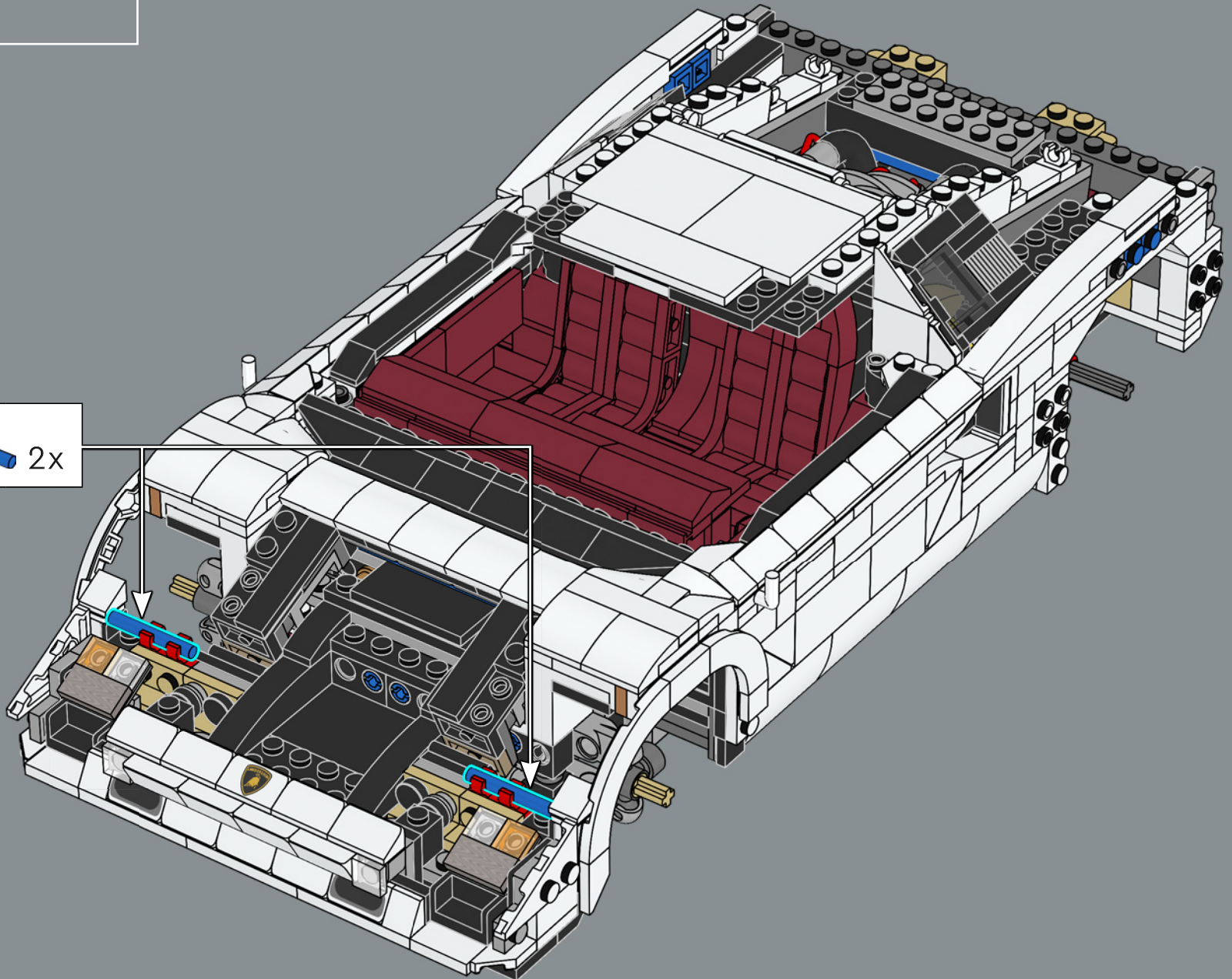



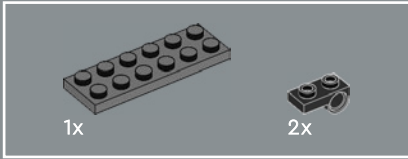
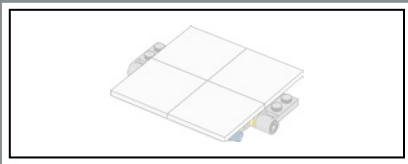

291

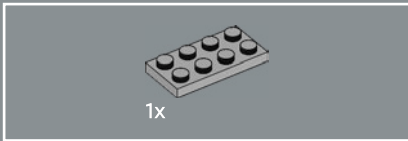
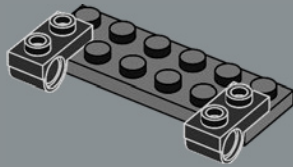

292

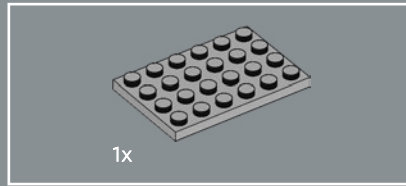
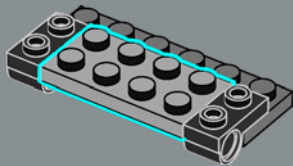

293

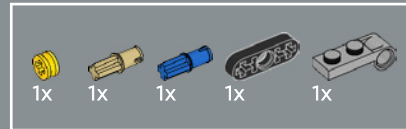
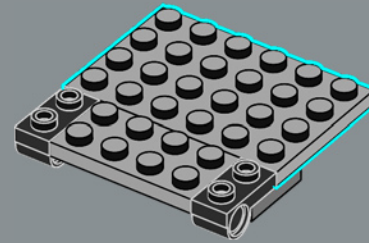

294

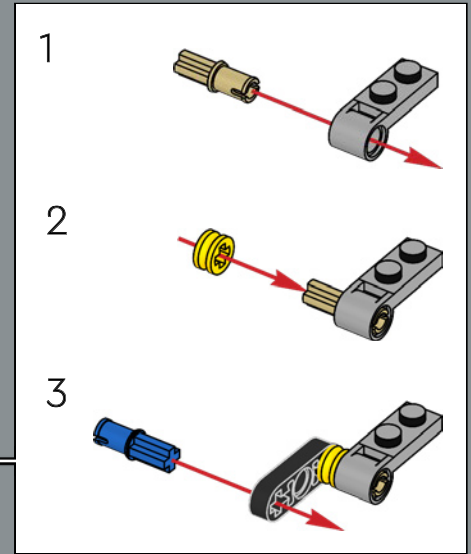
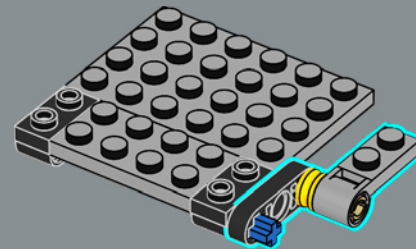



295

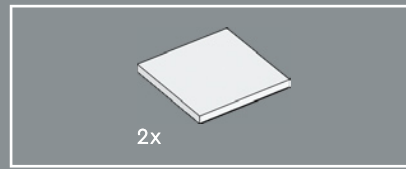
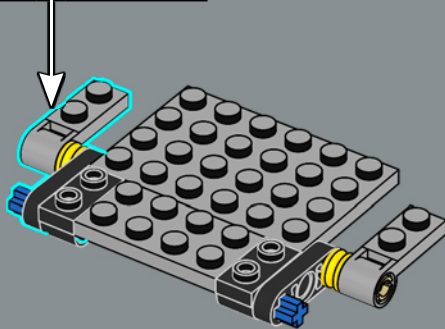
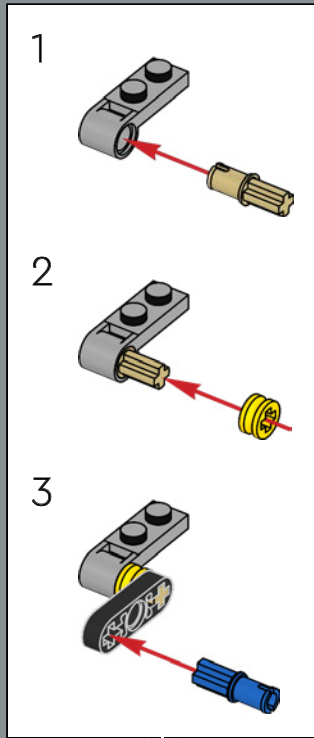

296

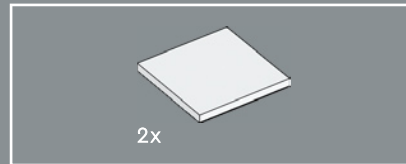
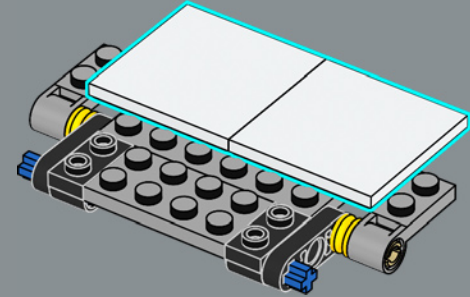

297

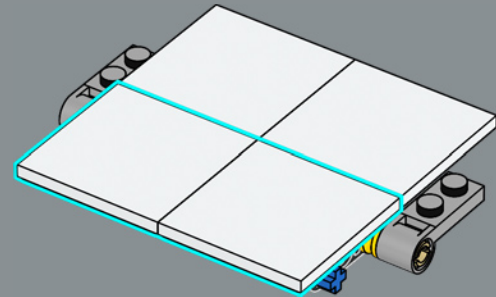

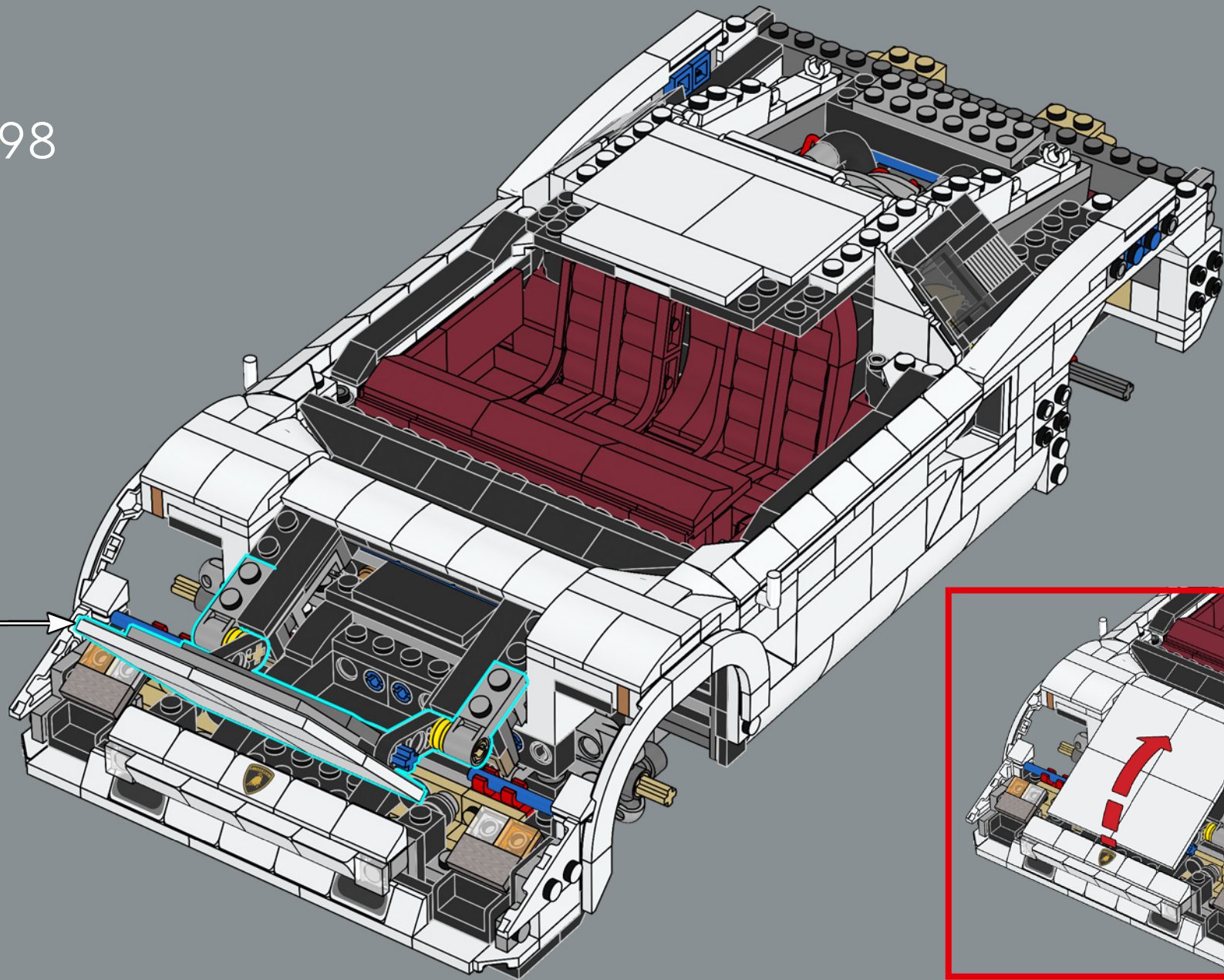



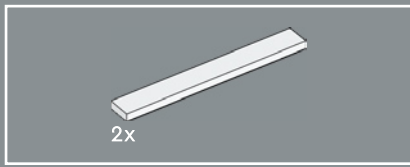

299

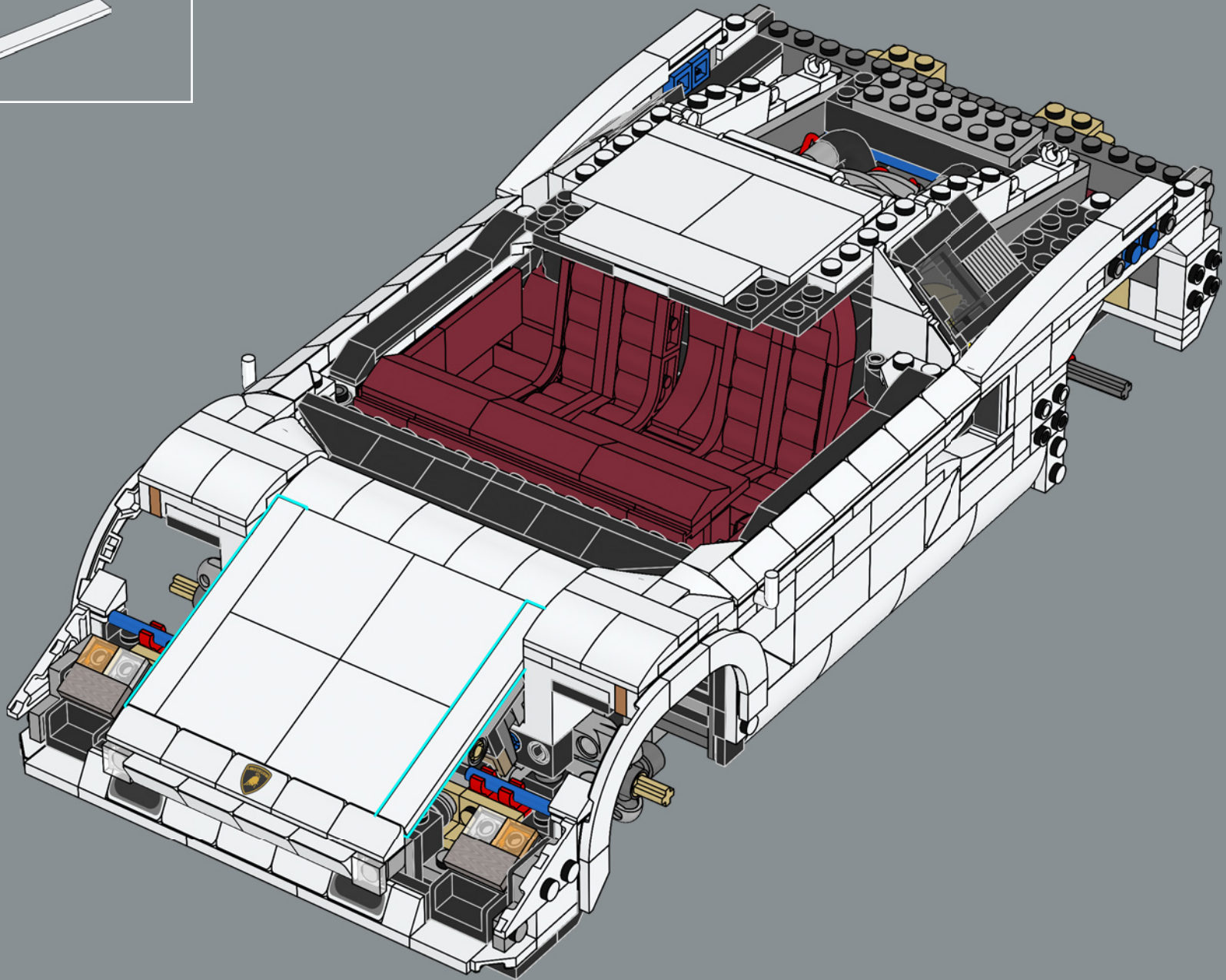

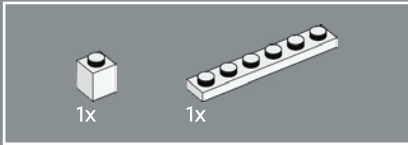
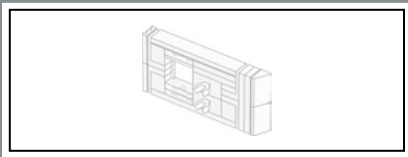

300

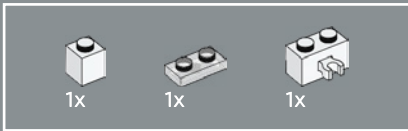
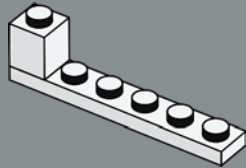

301

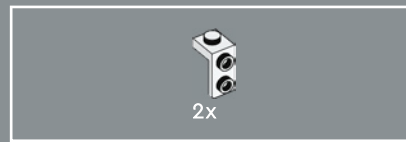
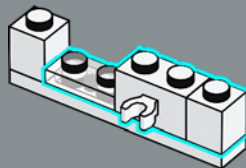

302

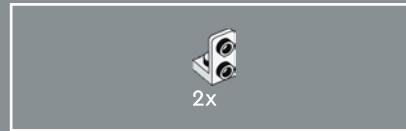
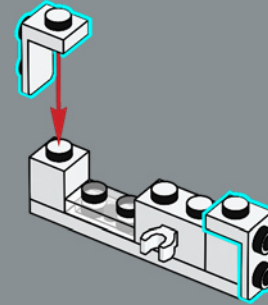

303

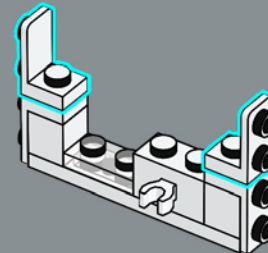

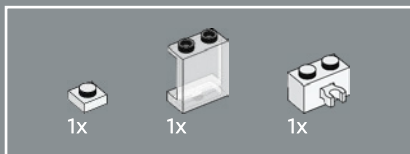

304

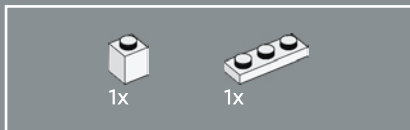
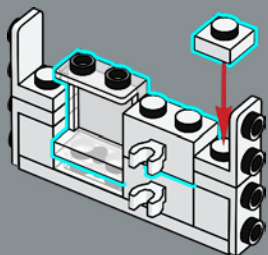

305

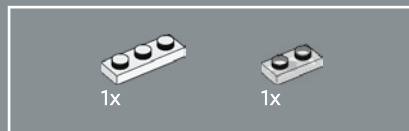
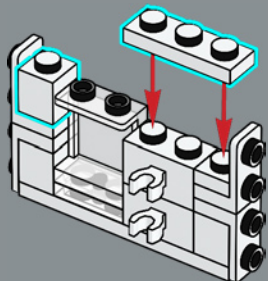

306

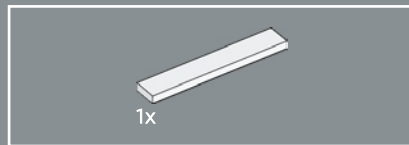
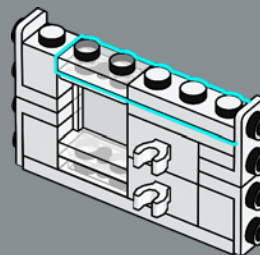

307

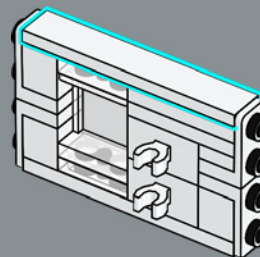





2x

308

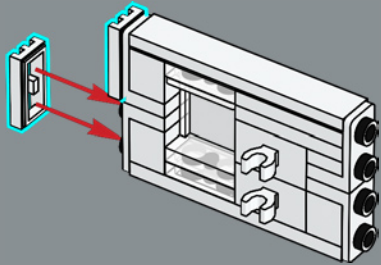

2x



2x

309

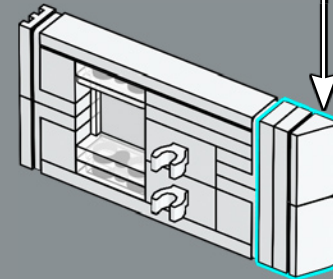
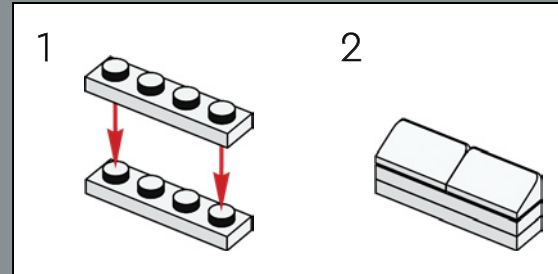

310

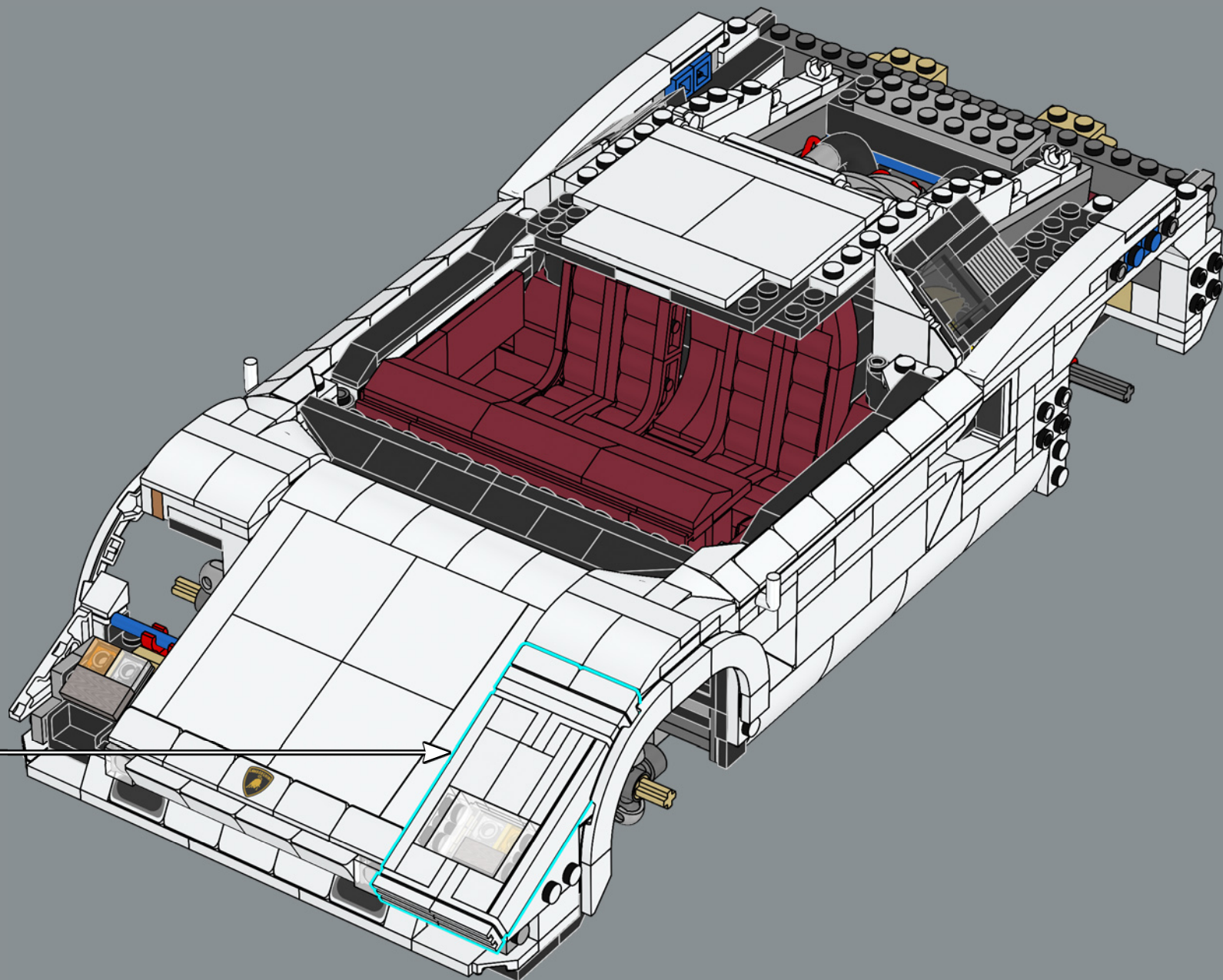

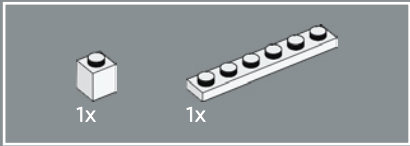
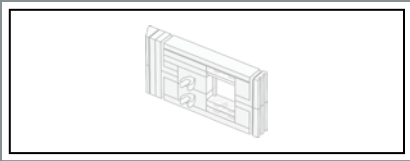

311

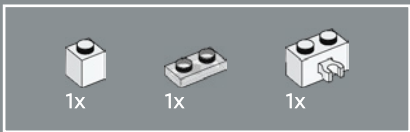
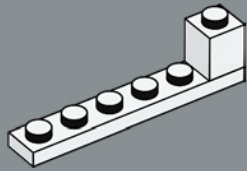

312

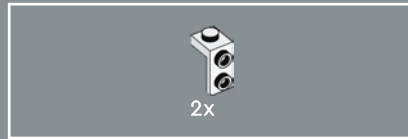
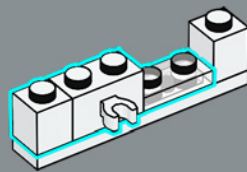

313

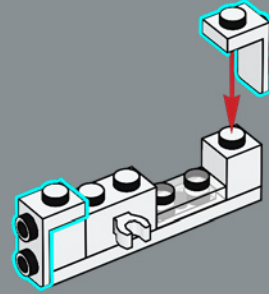

314

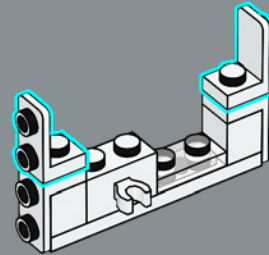



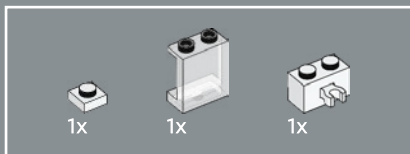

315

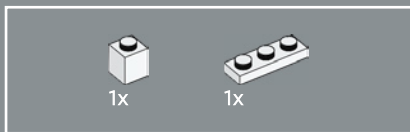
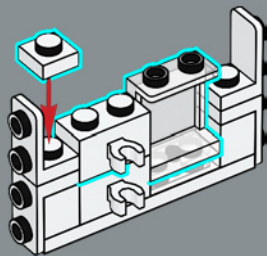

316

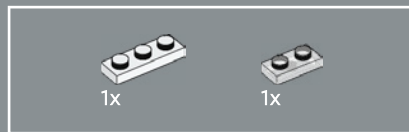
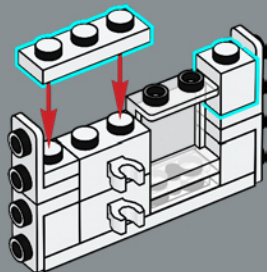

317

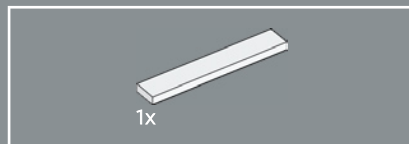
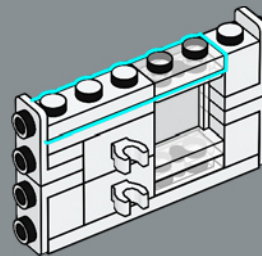

318

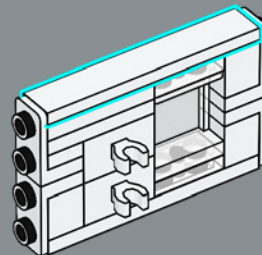



2x

319

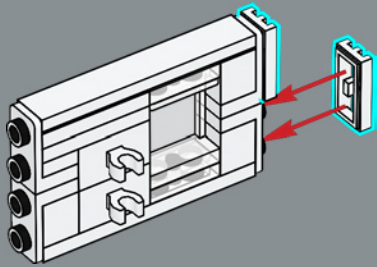

2x



2x

320

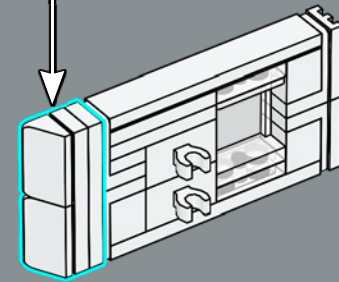
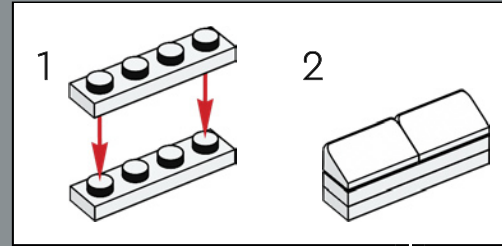

321

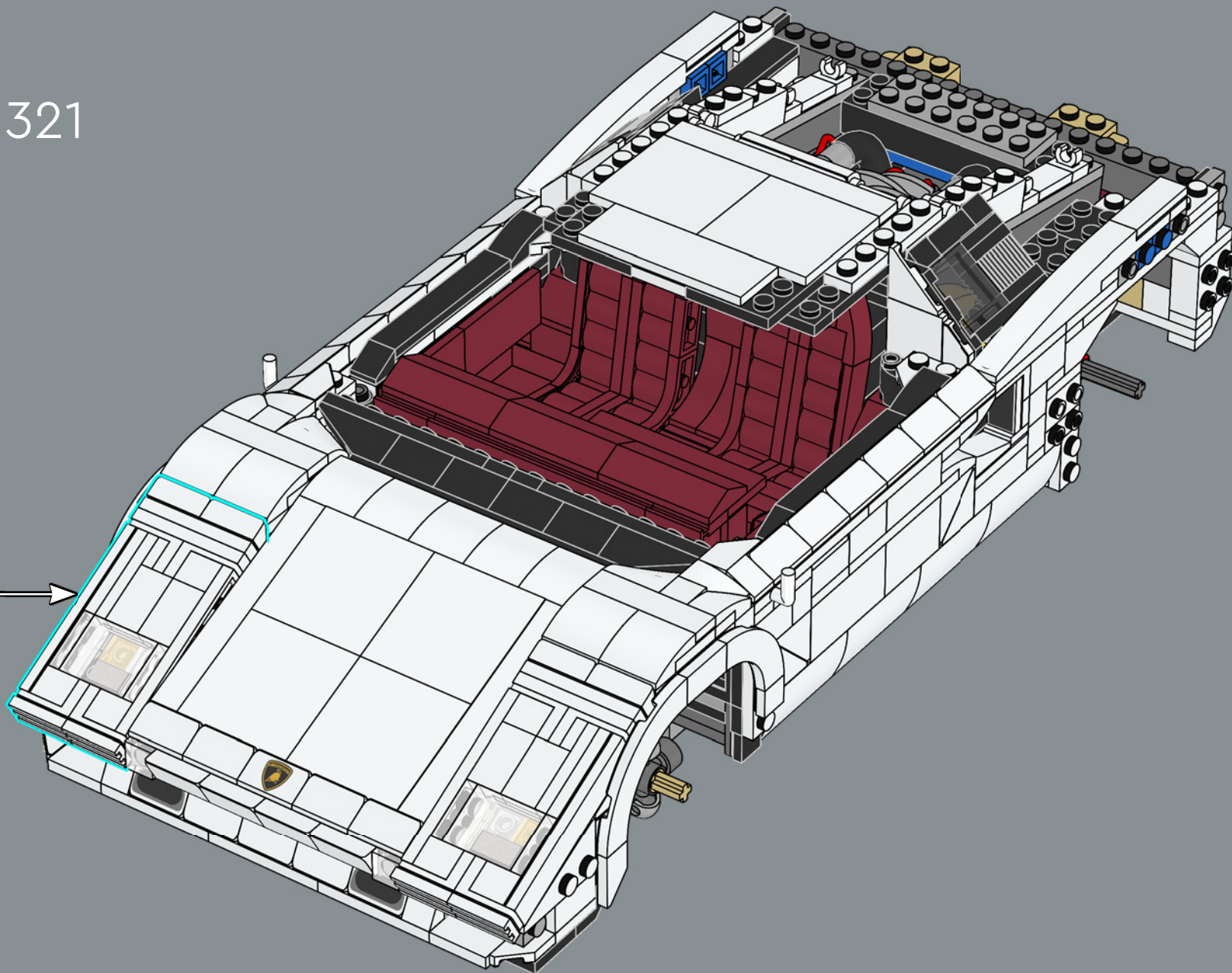



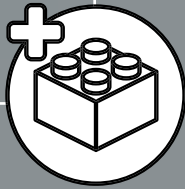
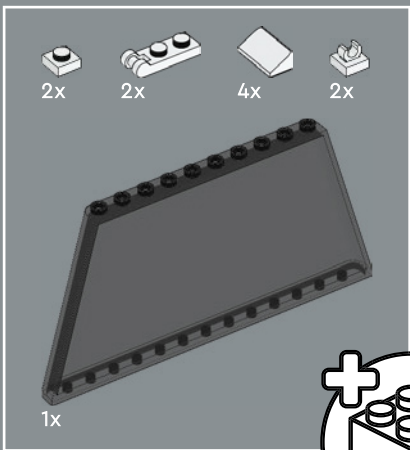

322

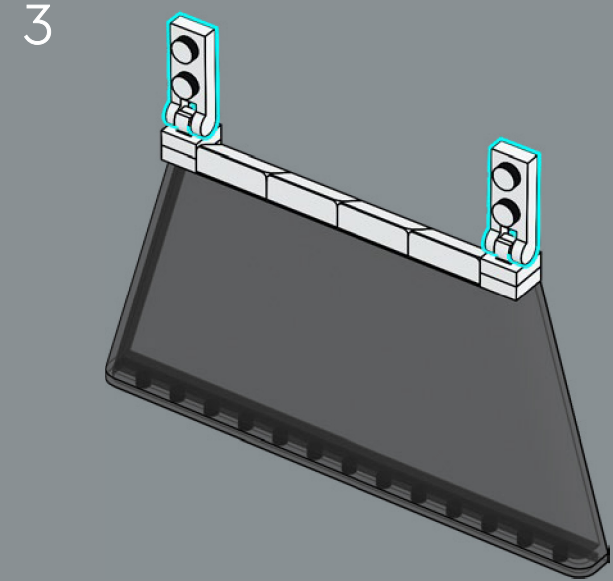
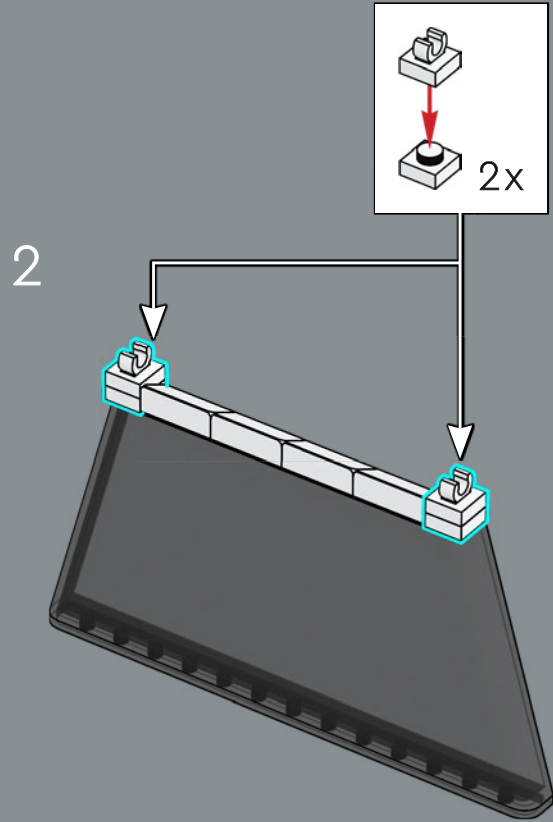
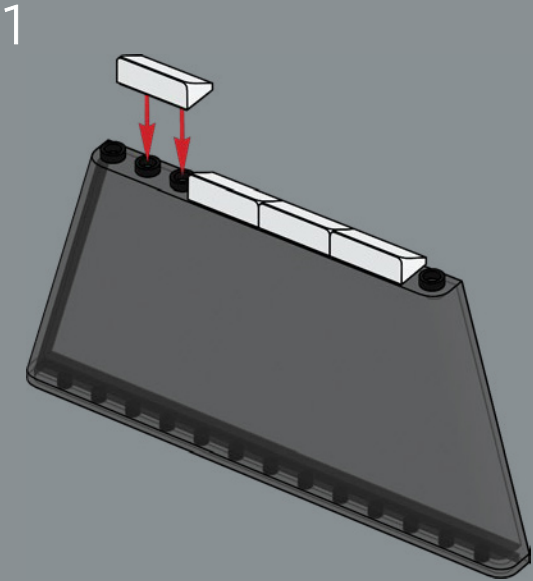

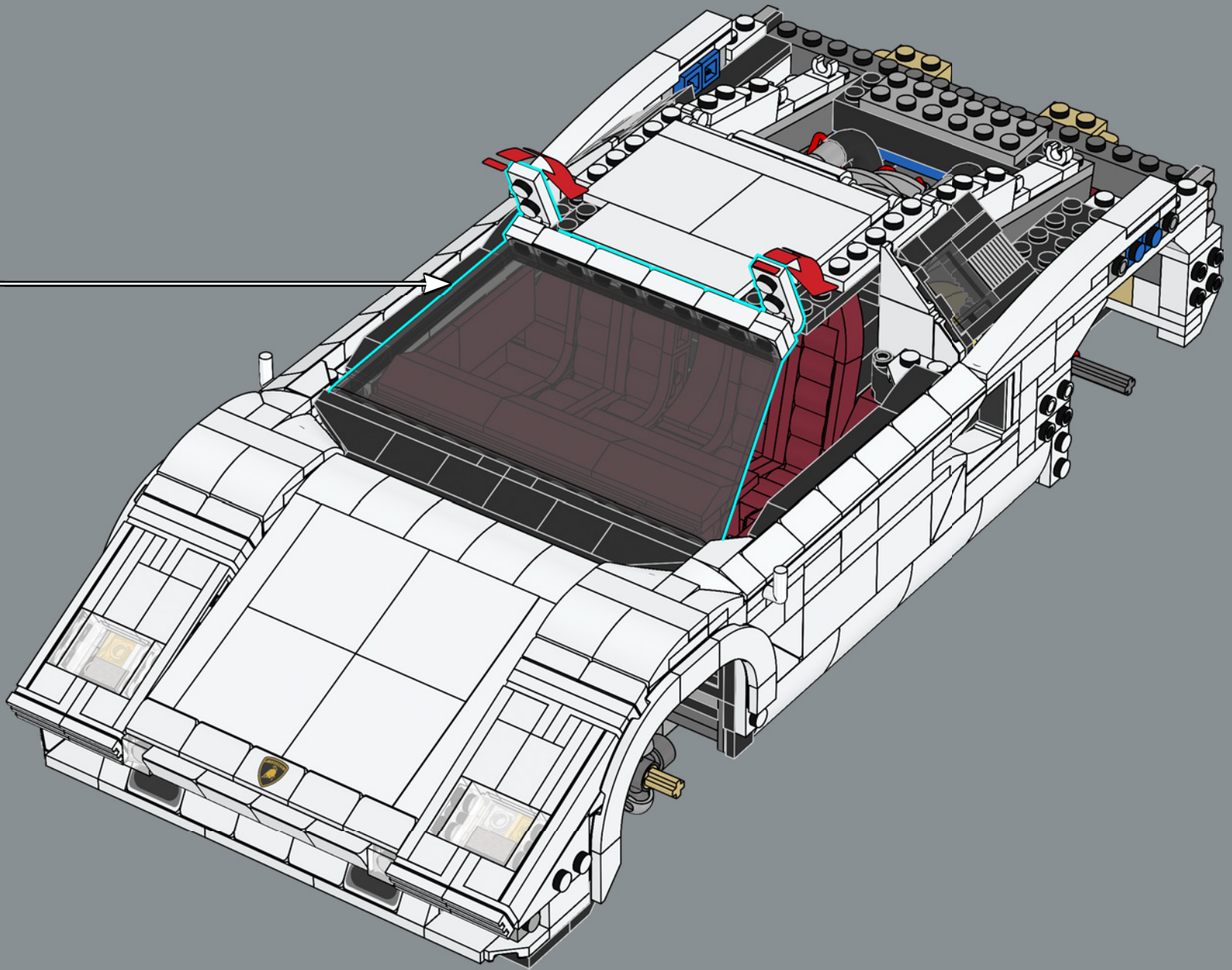

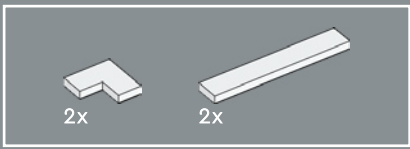

323

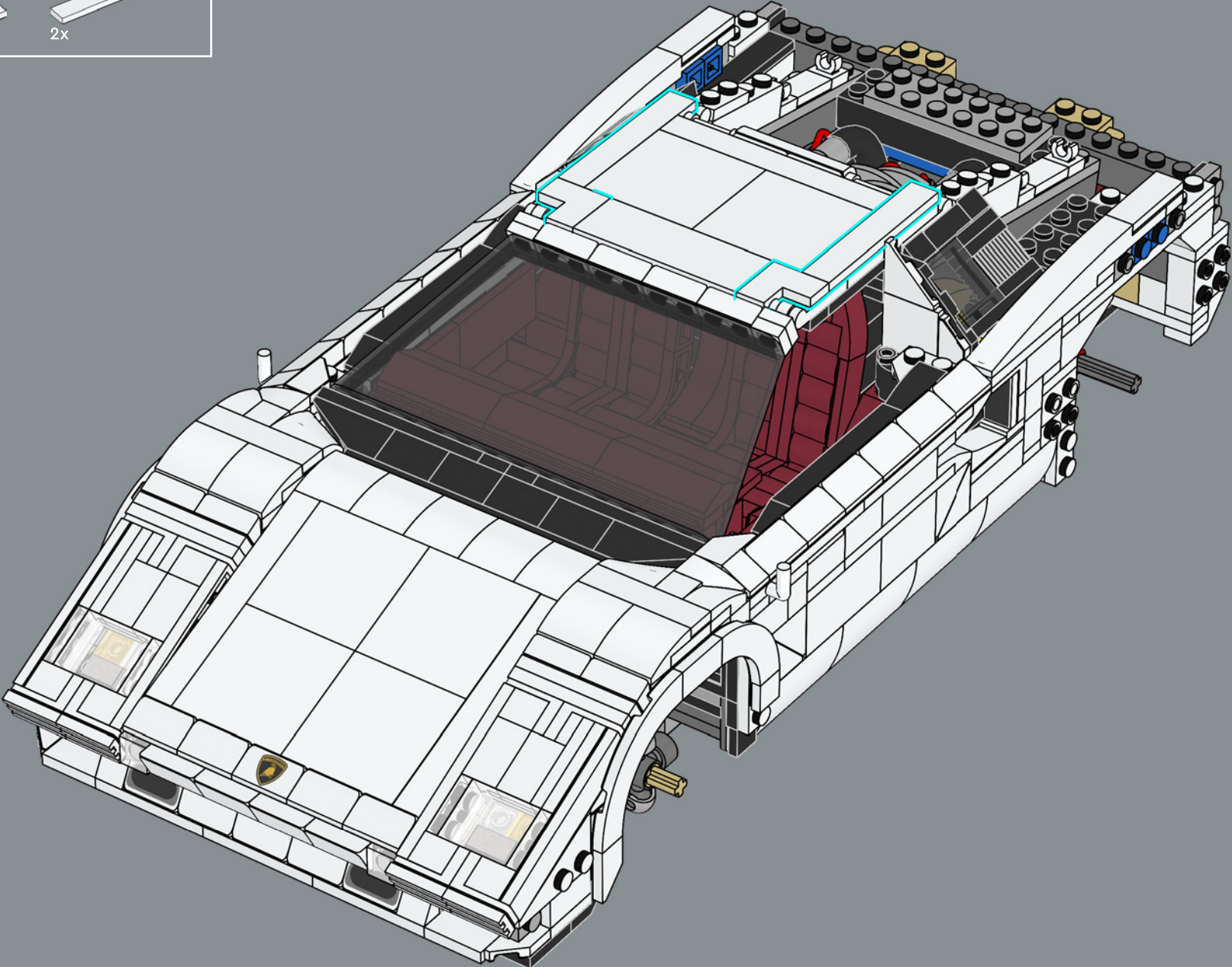



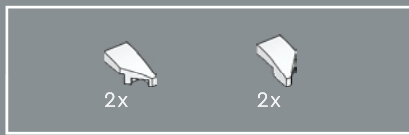

324

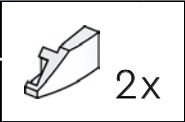
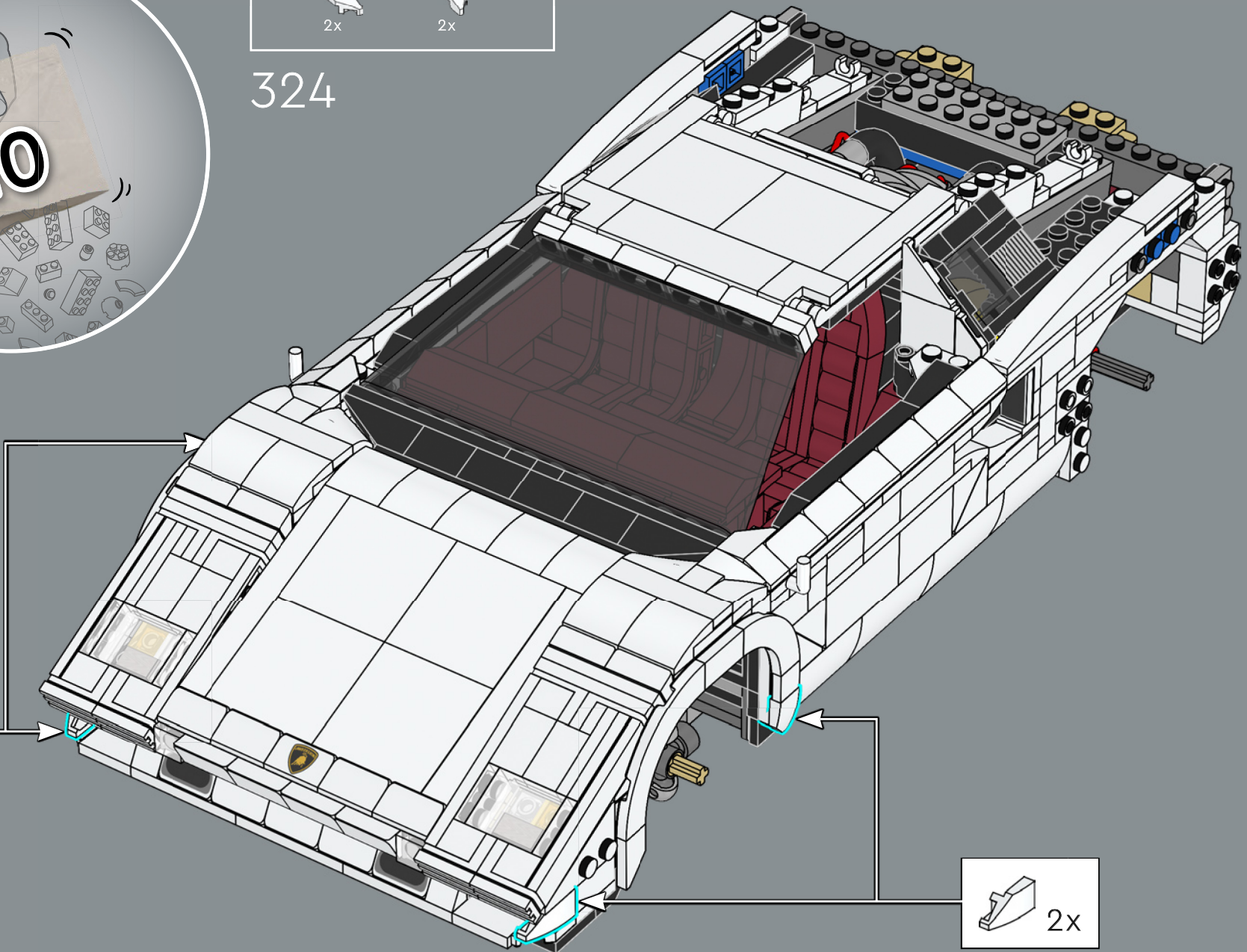

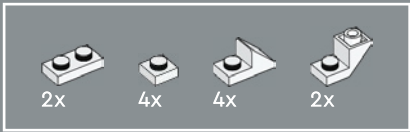

325

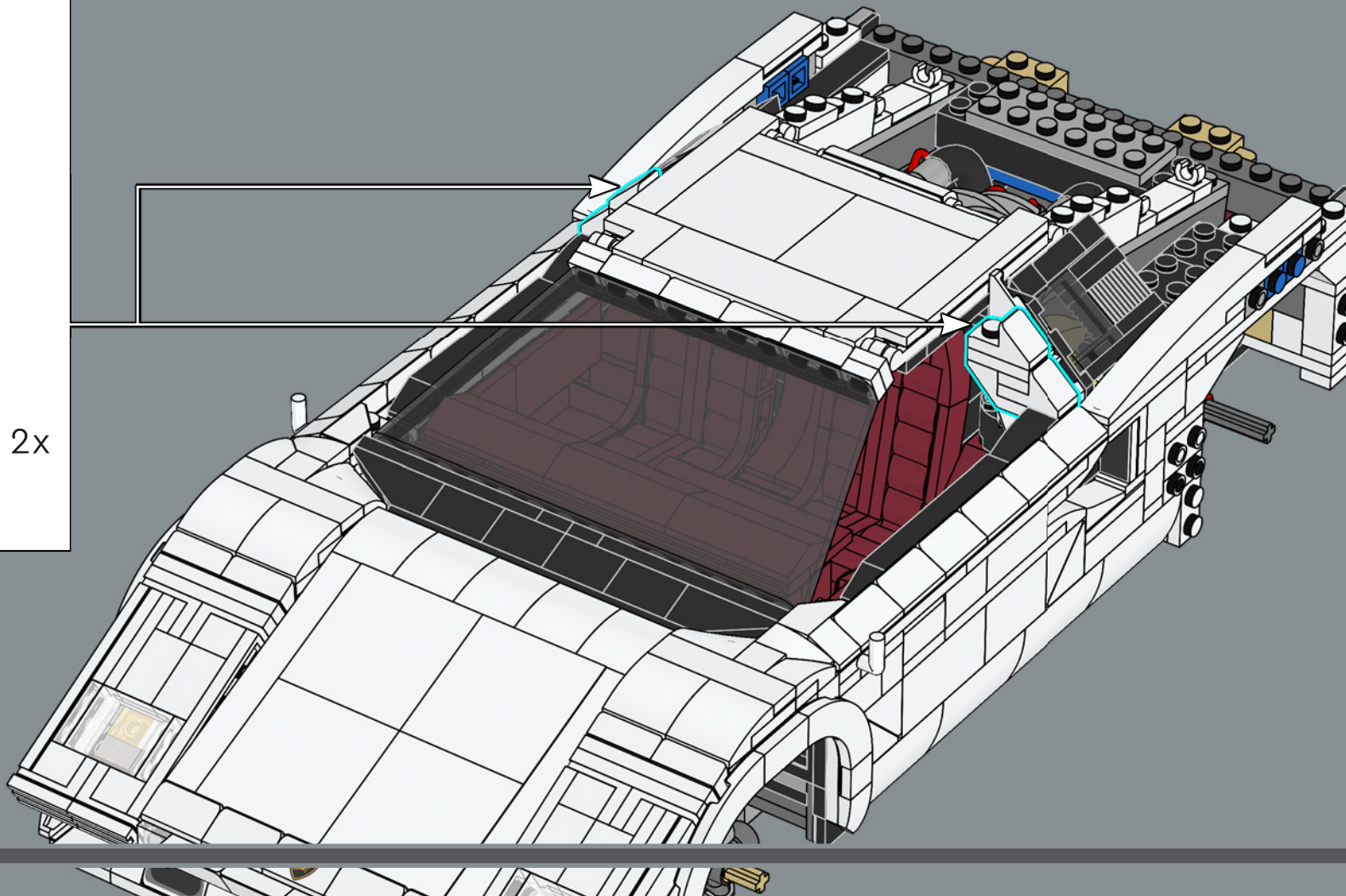
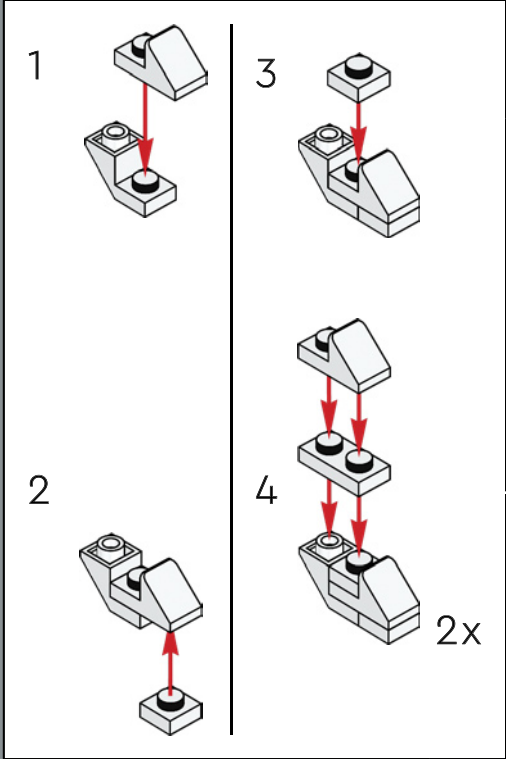

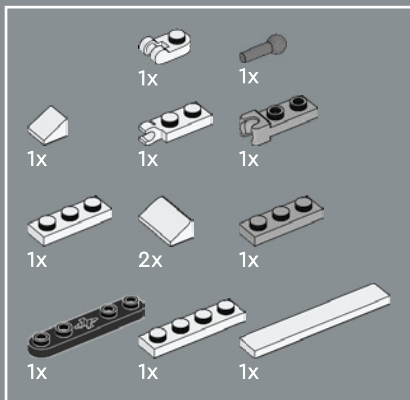

326

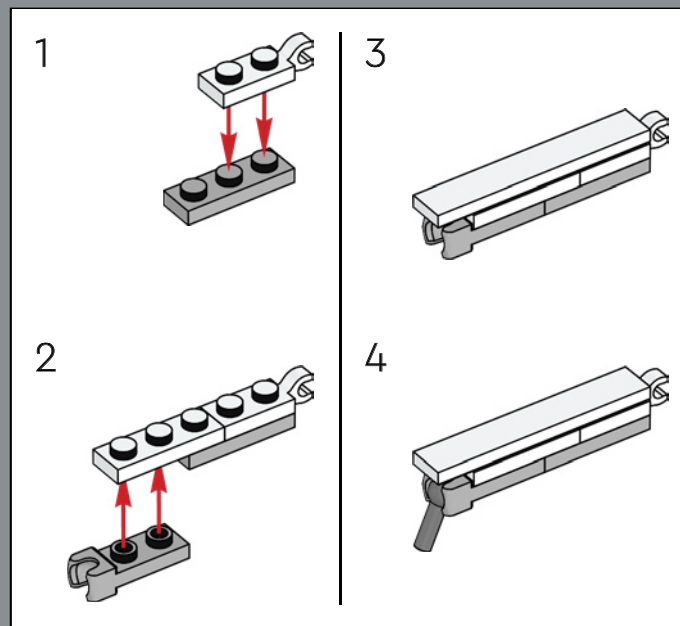
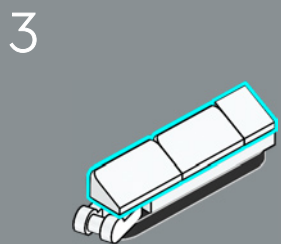
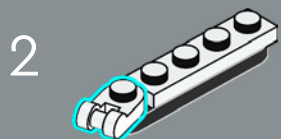
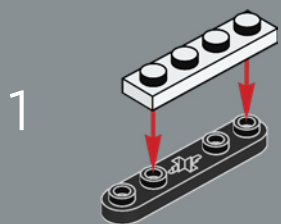

4

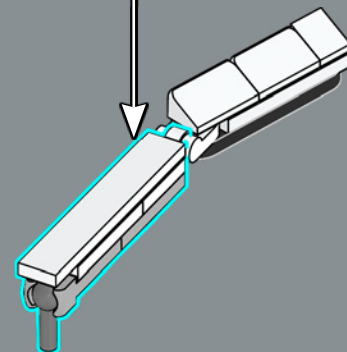



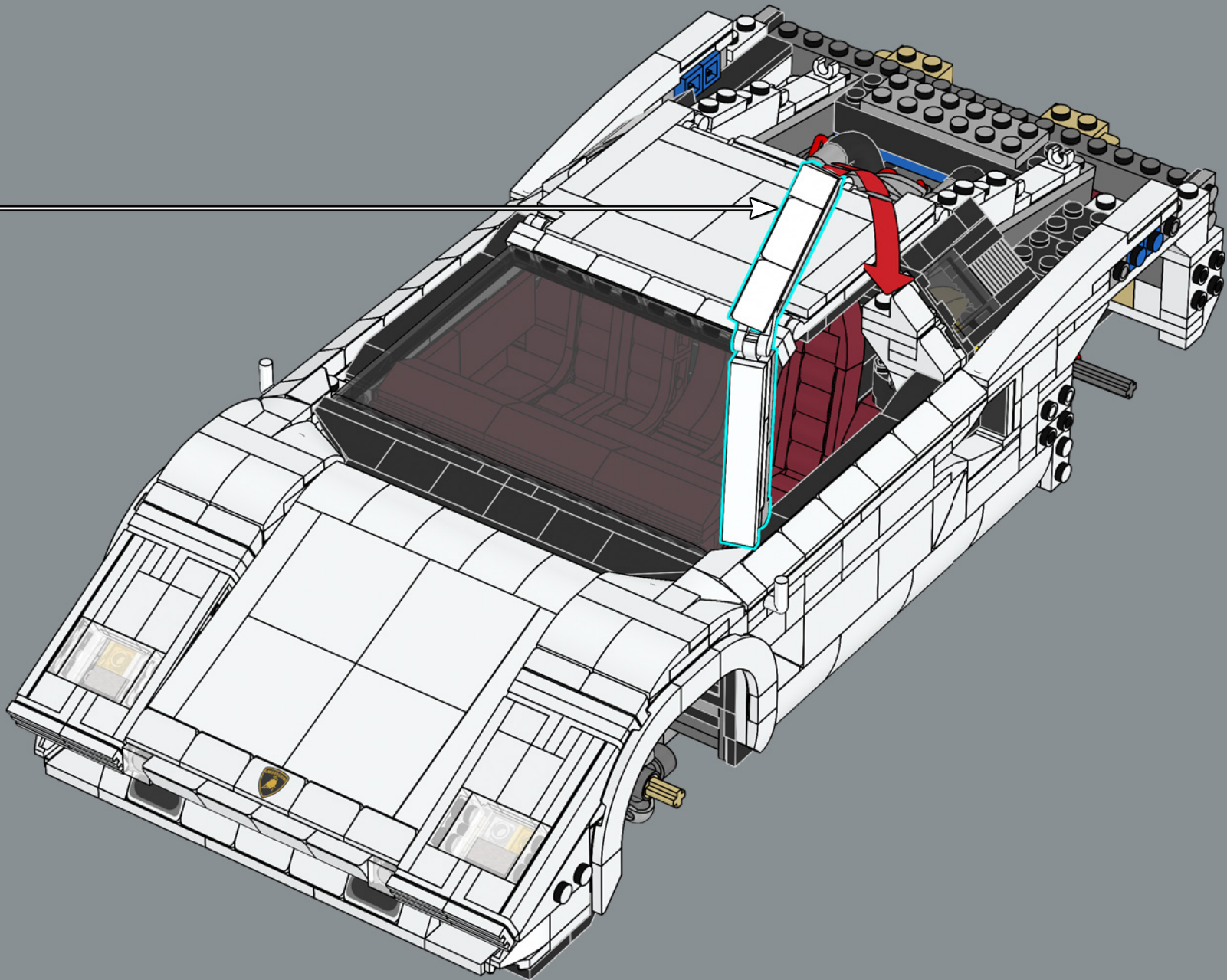

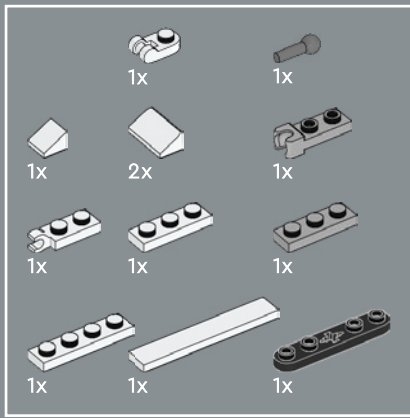

327

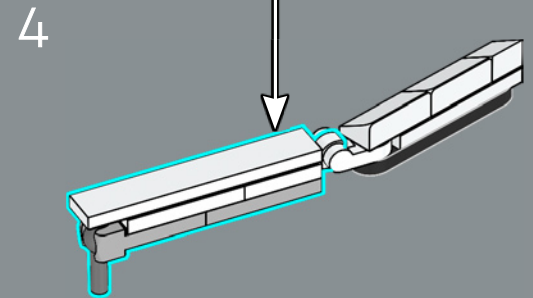
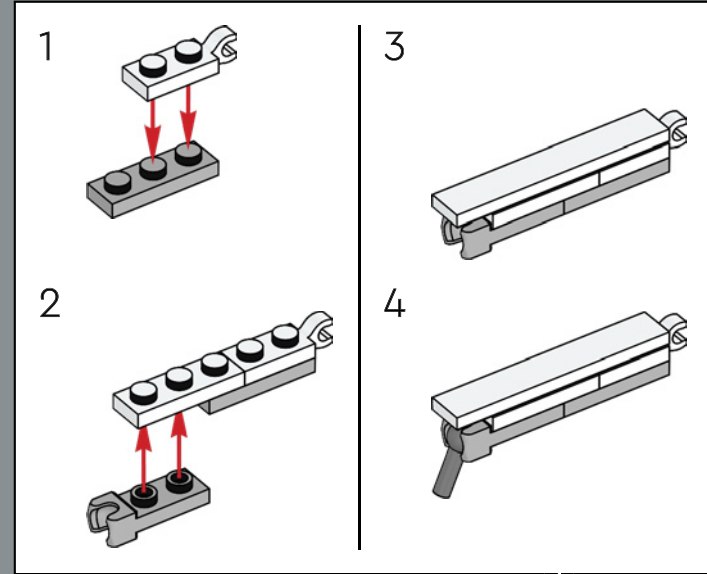
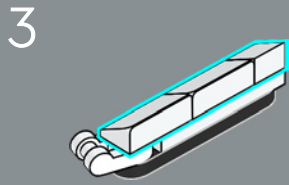
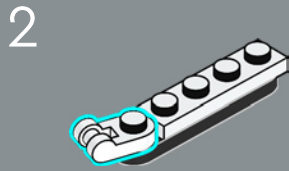
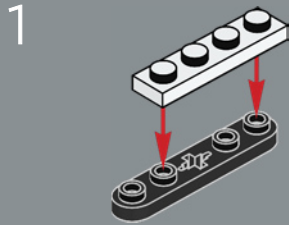

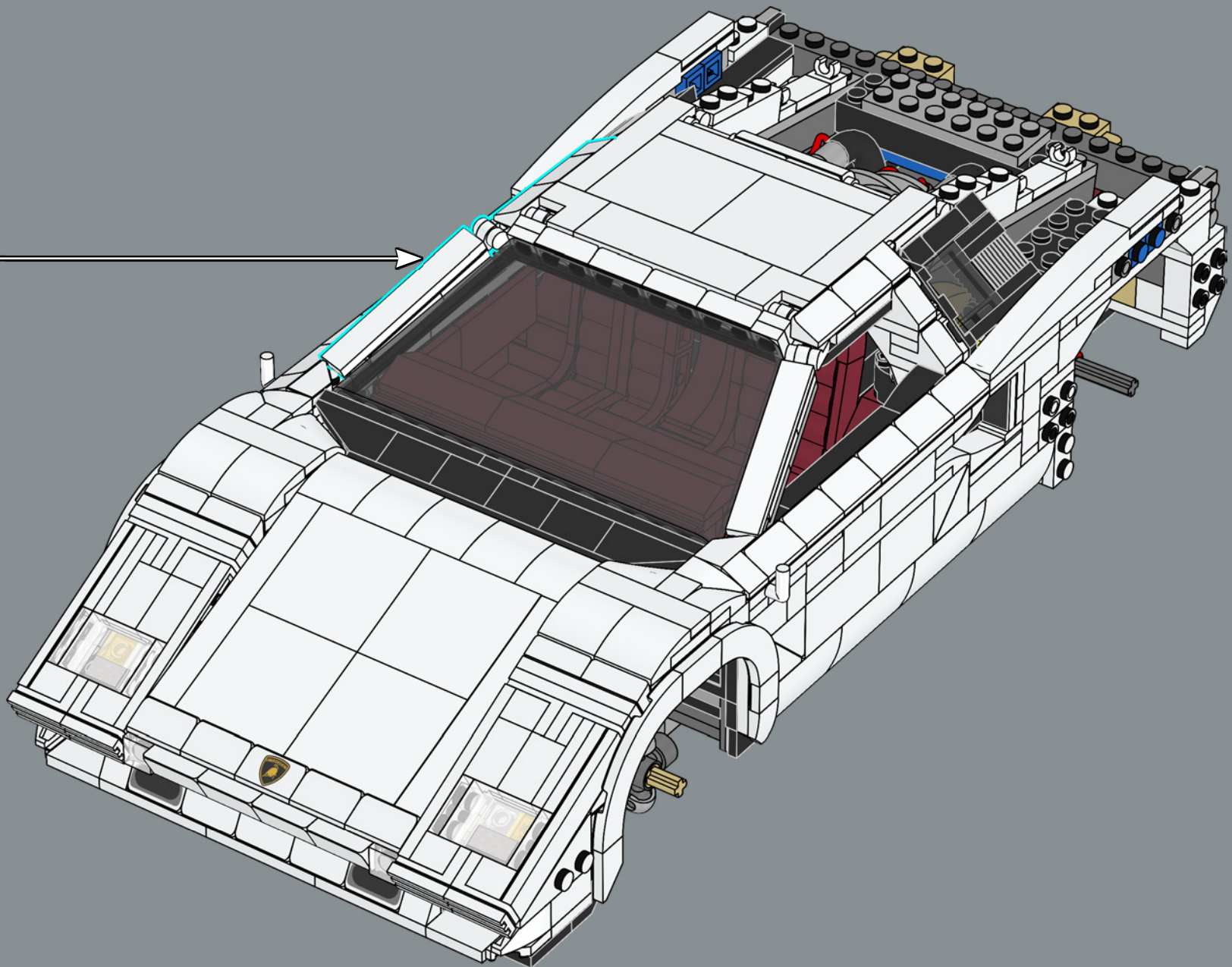



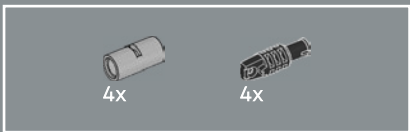

328

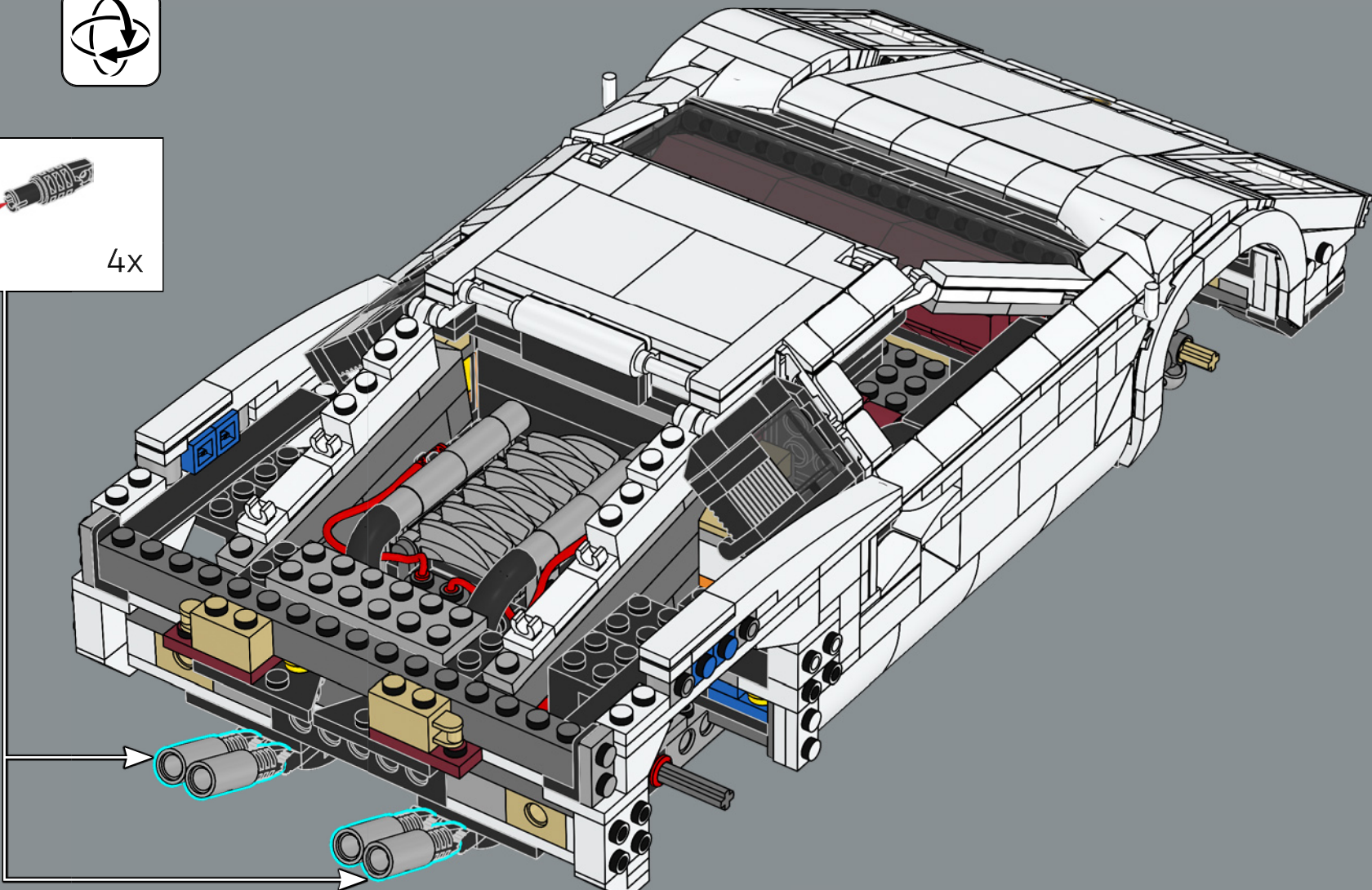
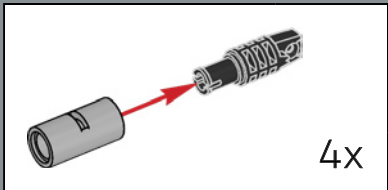

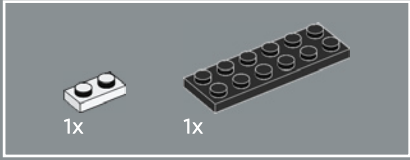
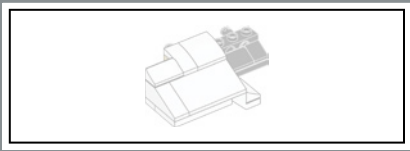

329

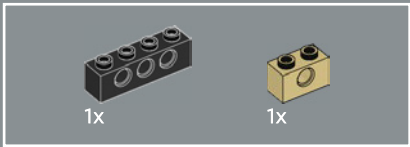
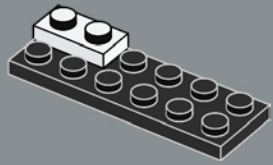

330

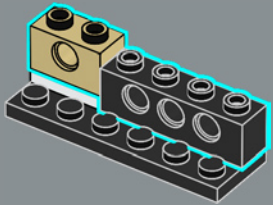

331

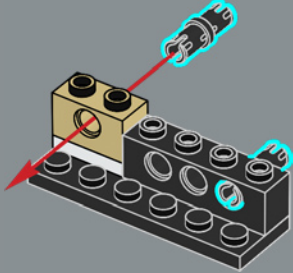

332

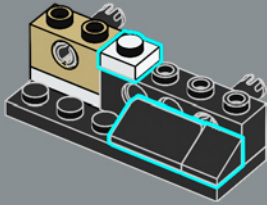

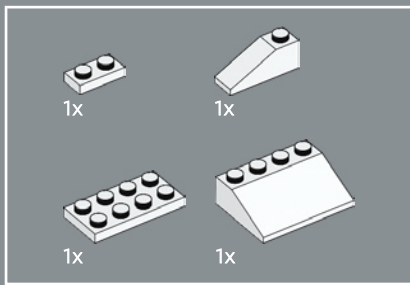

333

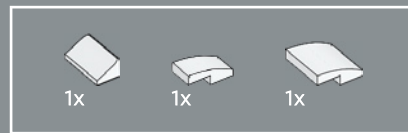
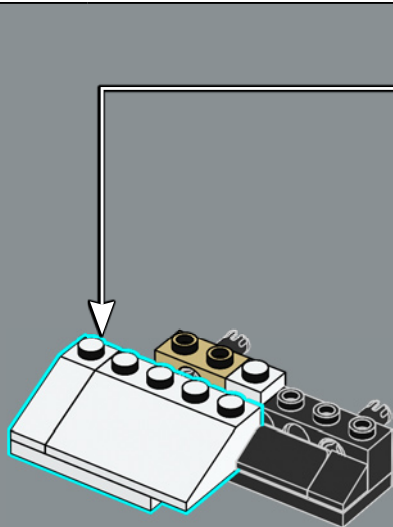
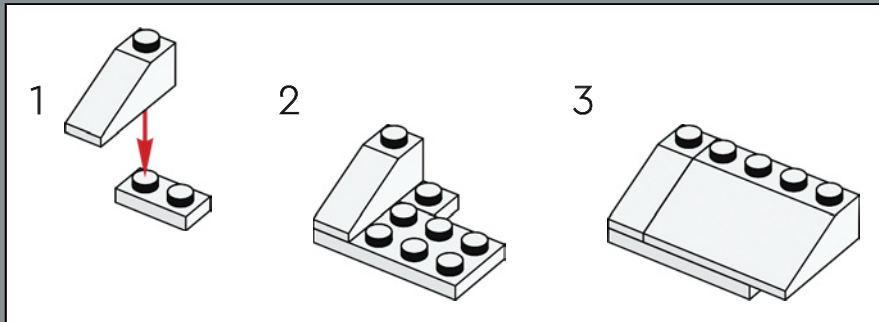

334

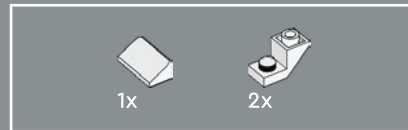
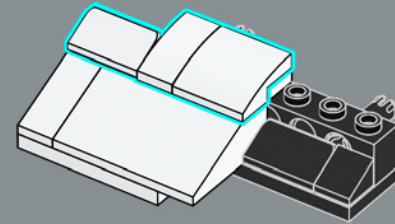

335

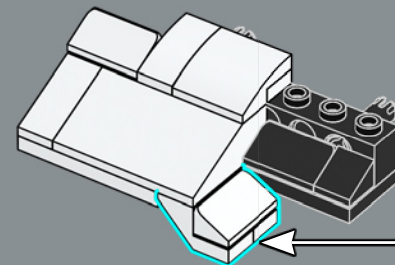
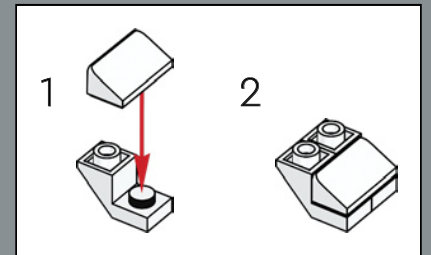



336

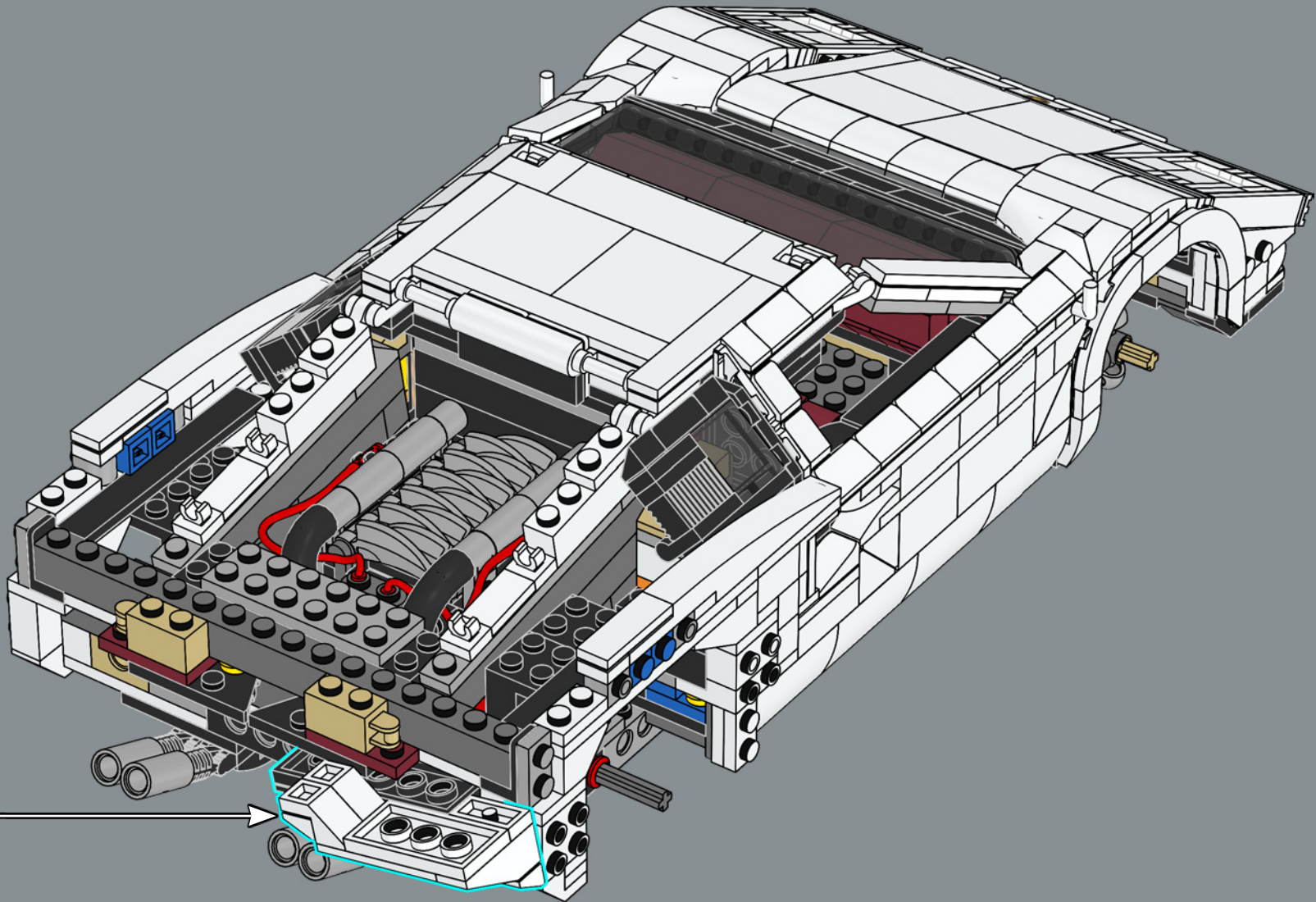

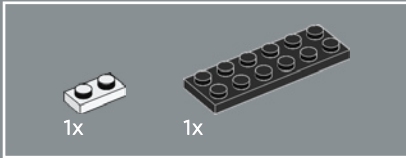
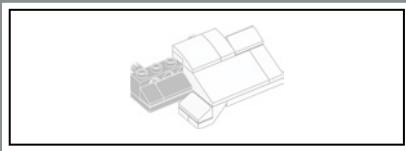

337

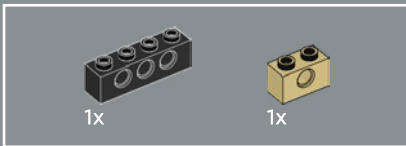
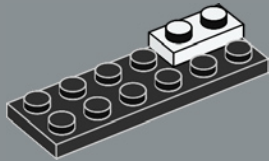

338

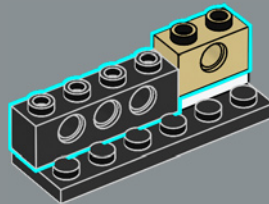

339

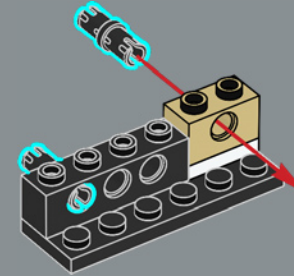

340

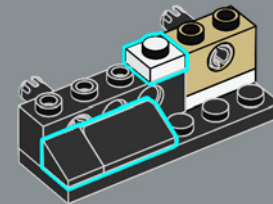

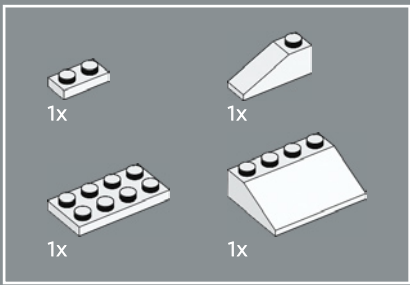

341

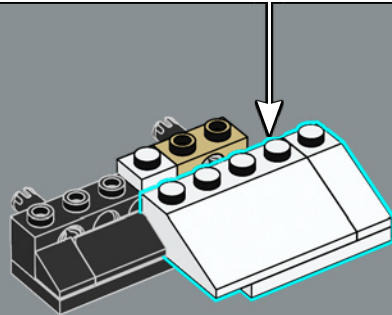
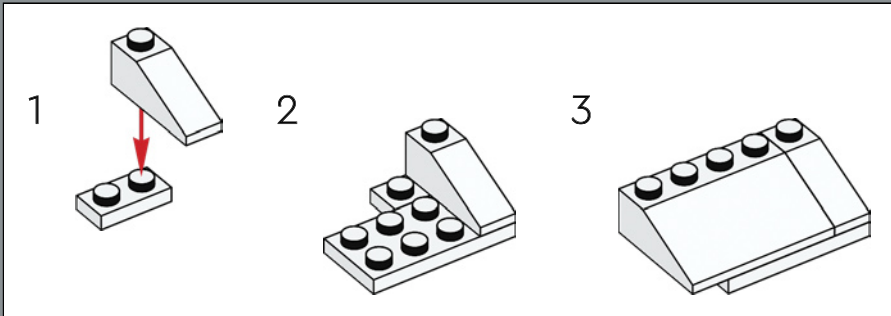

342

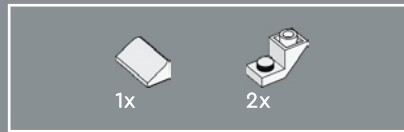
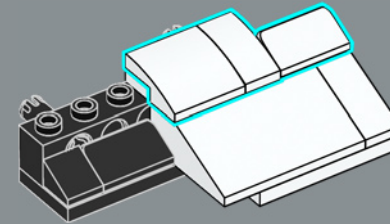

343

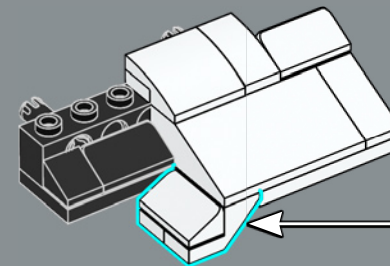
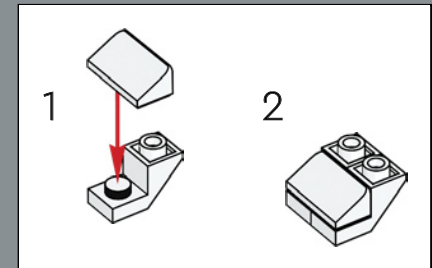



344

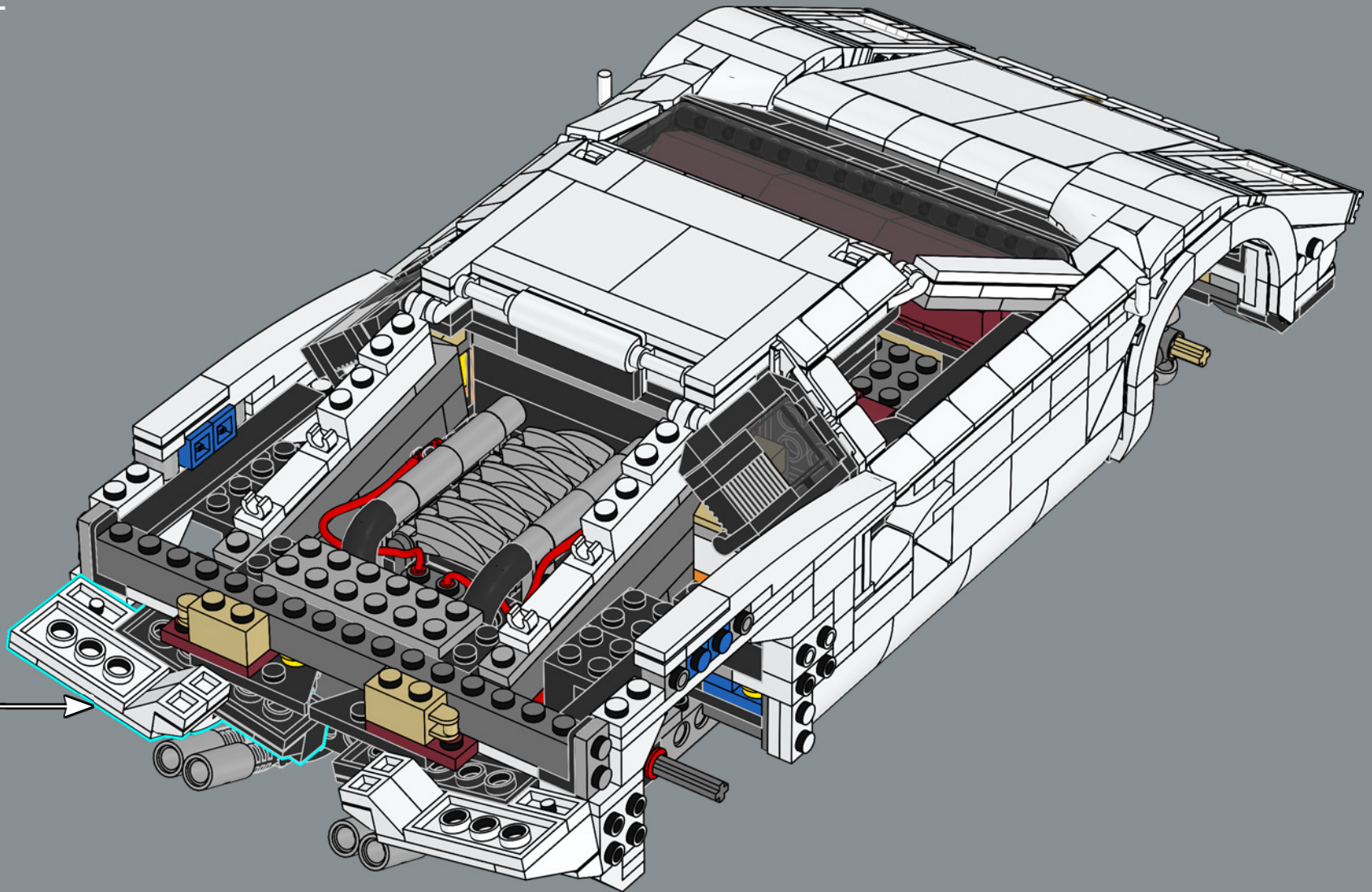

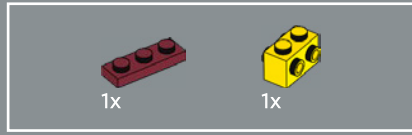
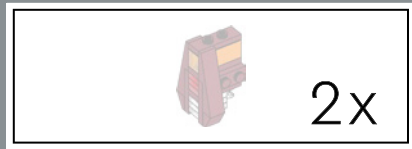

345

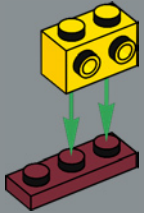

346

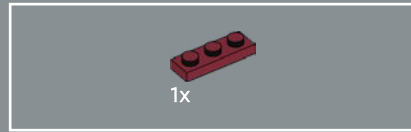
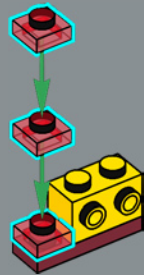

347

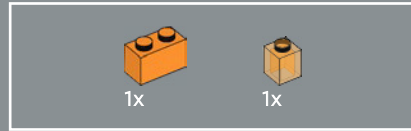
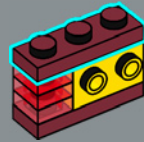

348

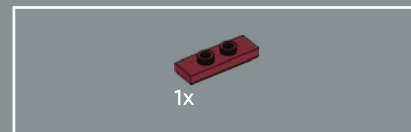

349

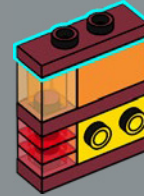

350

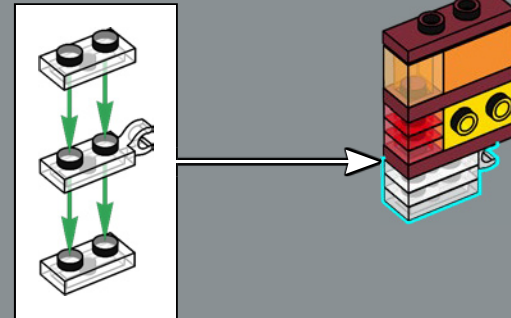
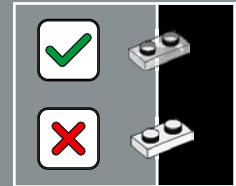

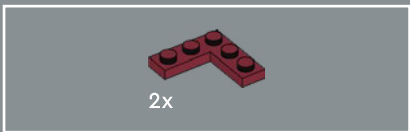

351

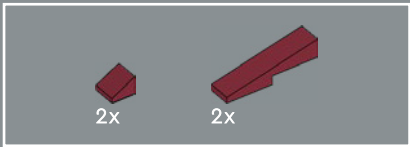
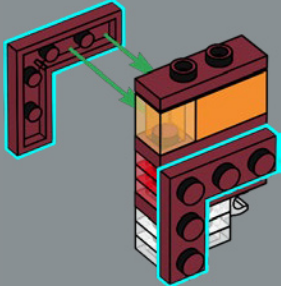

352

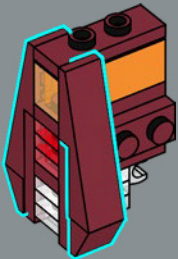

2x

353

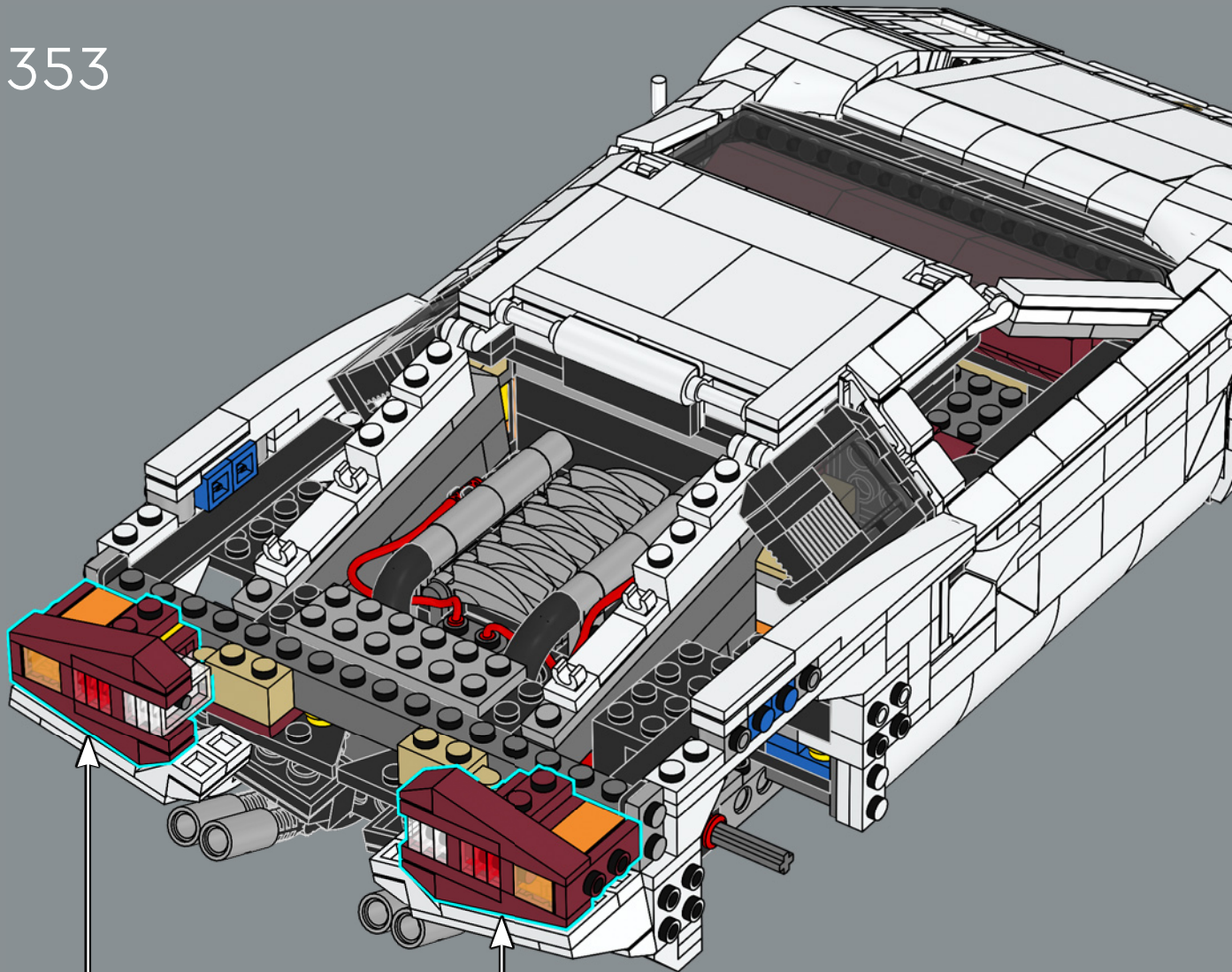



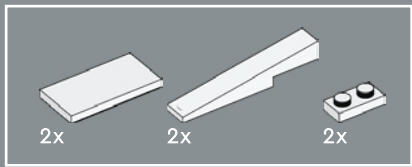

354

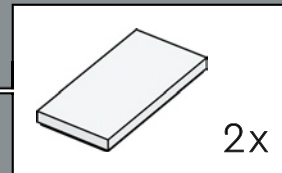
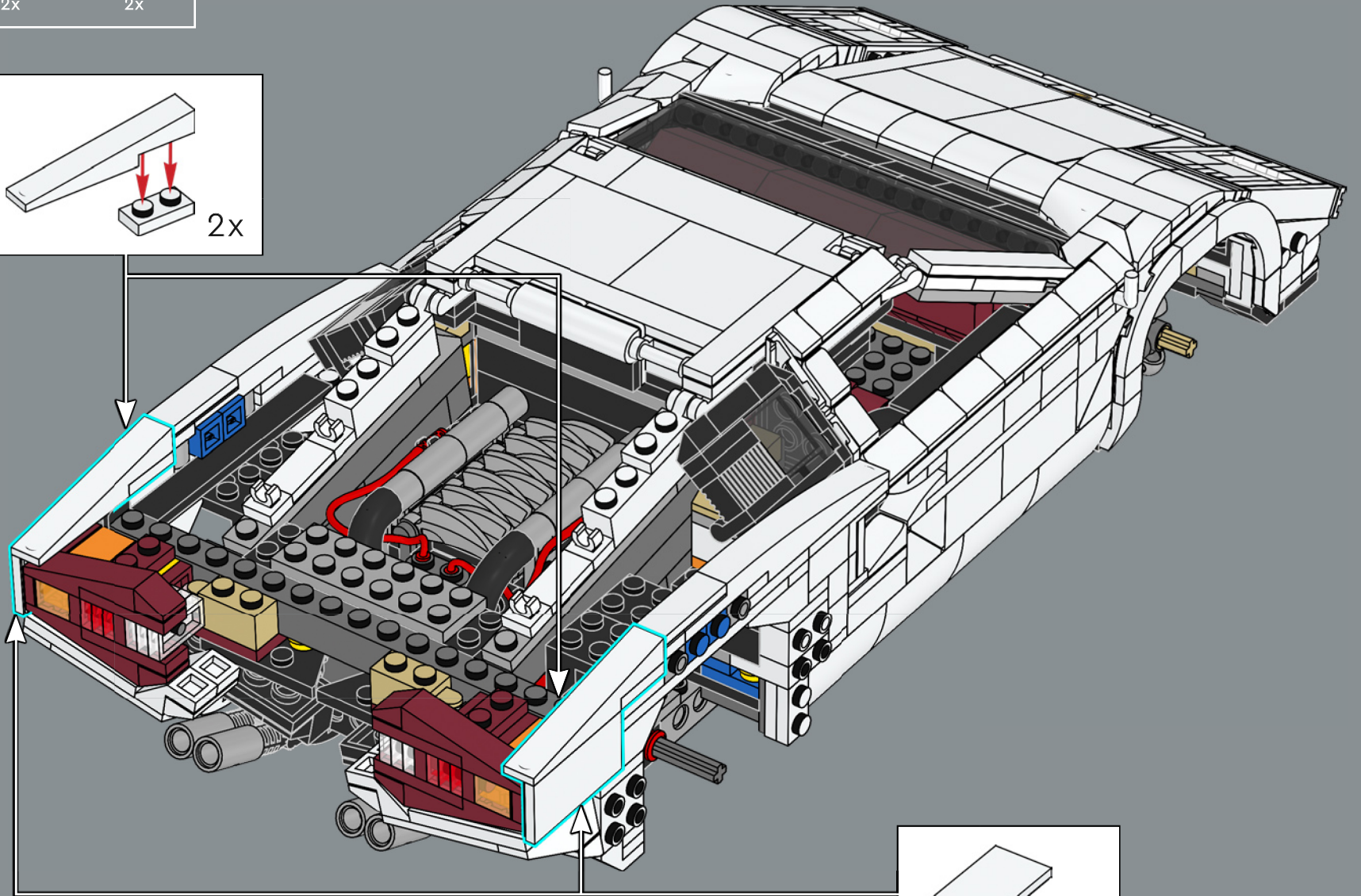
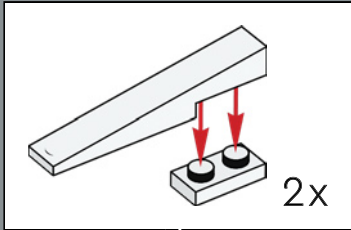

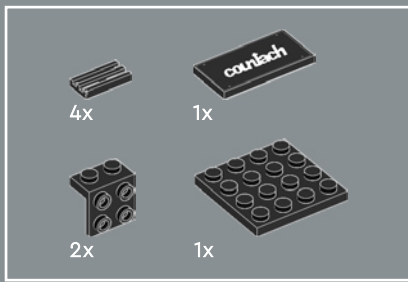

355

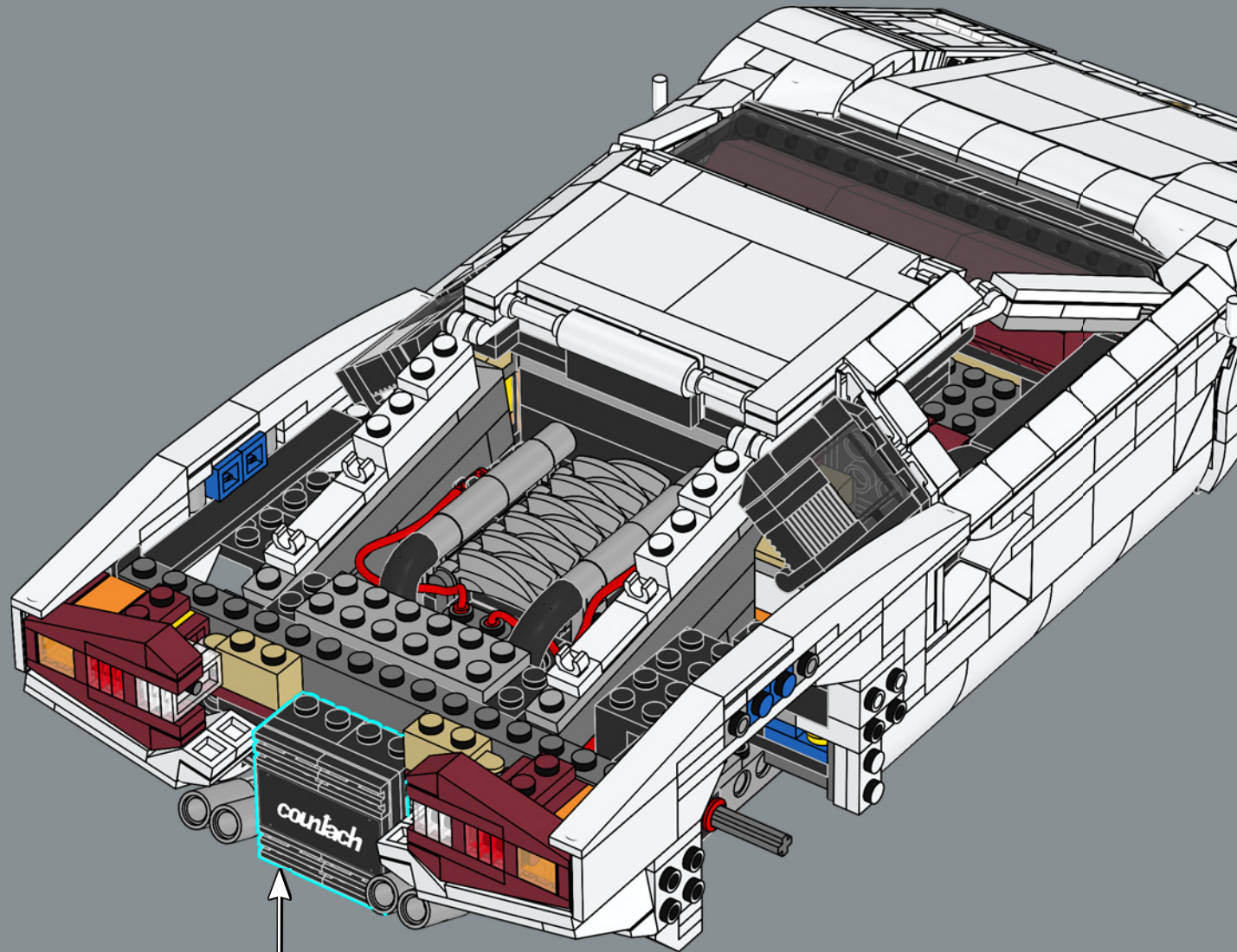
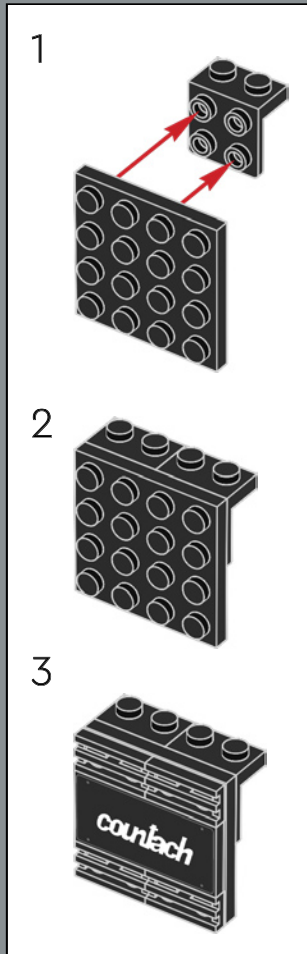



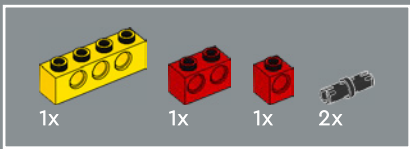

356

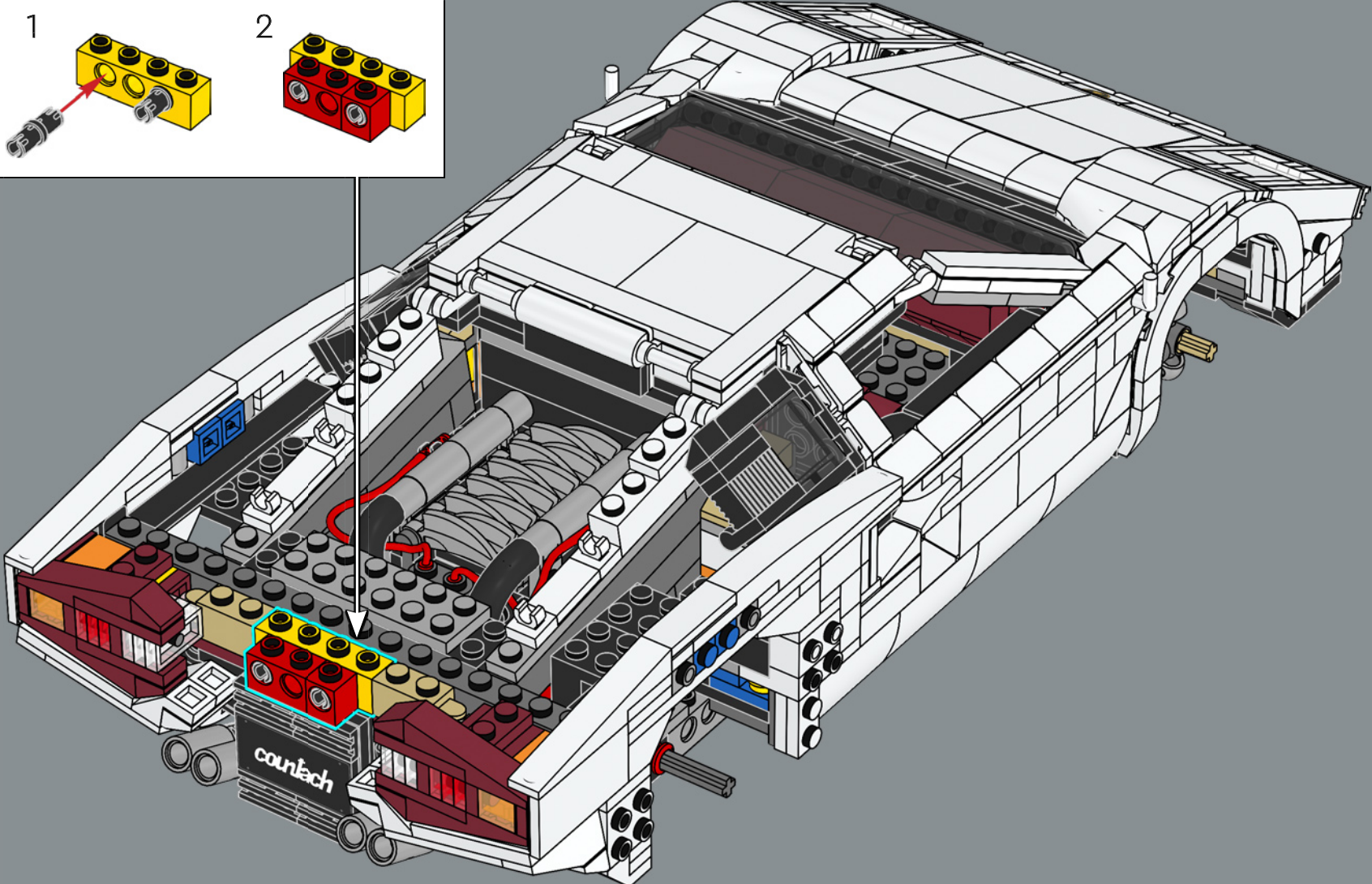
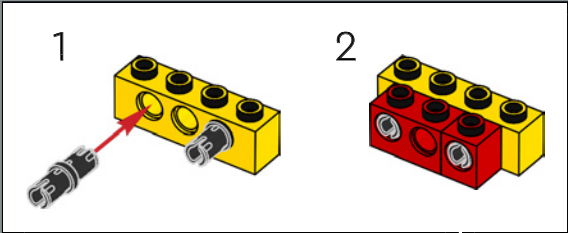



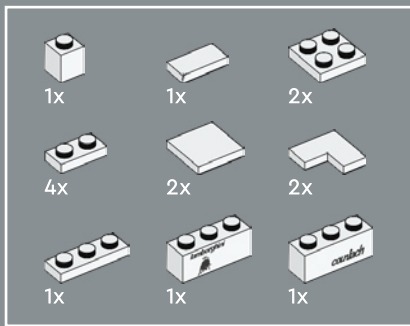

4

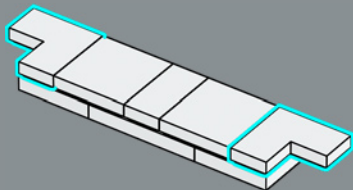

357

1

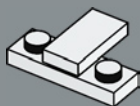

2

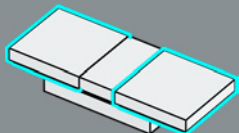

3

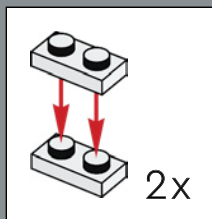
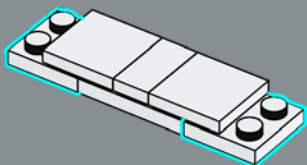

5

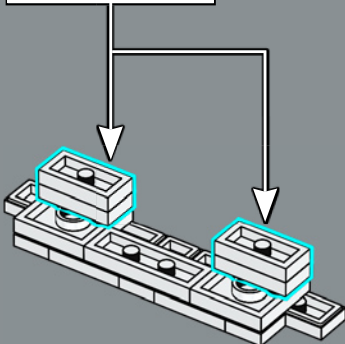

6

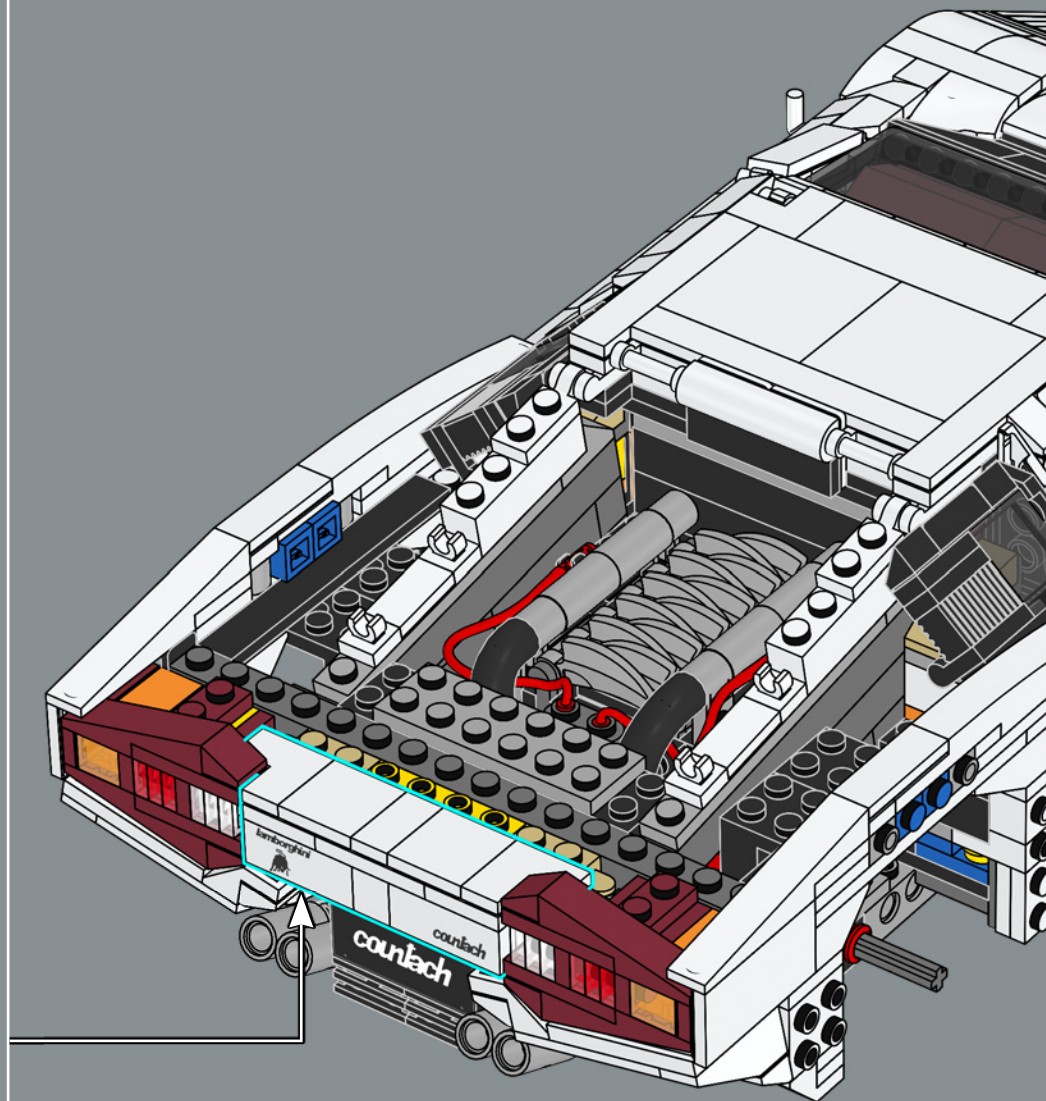
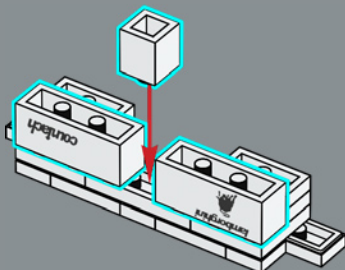

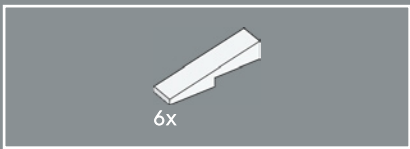

# 358



A new LEGO® slope element helps recreate short, shallow angles in the iconic design.

Un nouvel élément de pente LEGO® permet de recréer des angles courts et peu profonds de la conception emblématique.

Un nuevo elemento LEGO® con forma de cuña ayuda a recrear los ángulos poco pronunciados del icónico diseño.

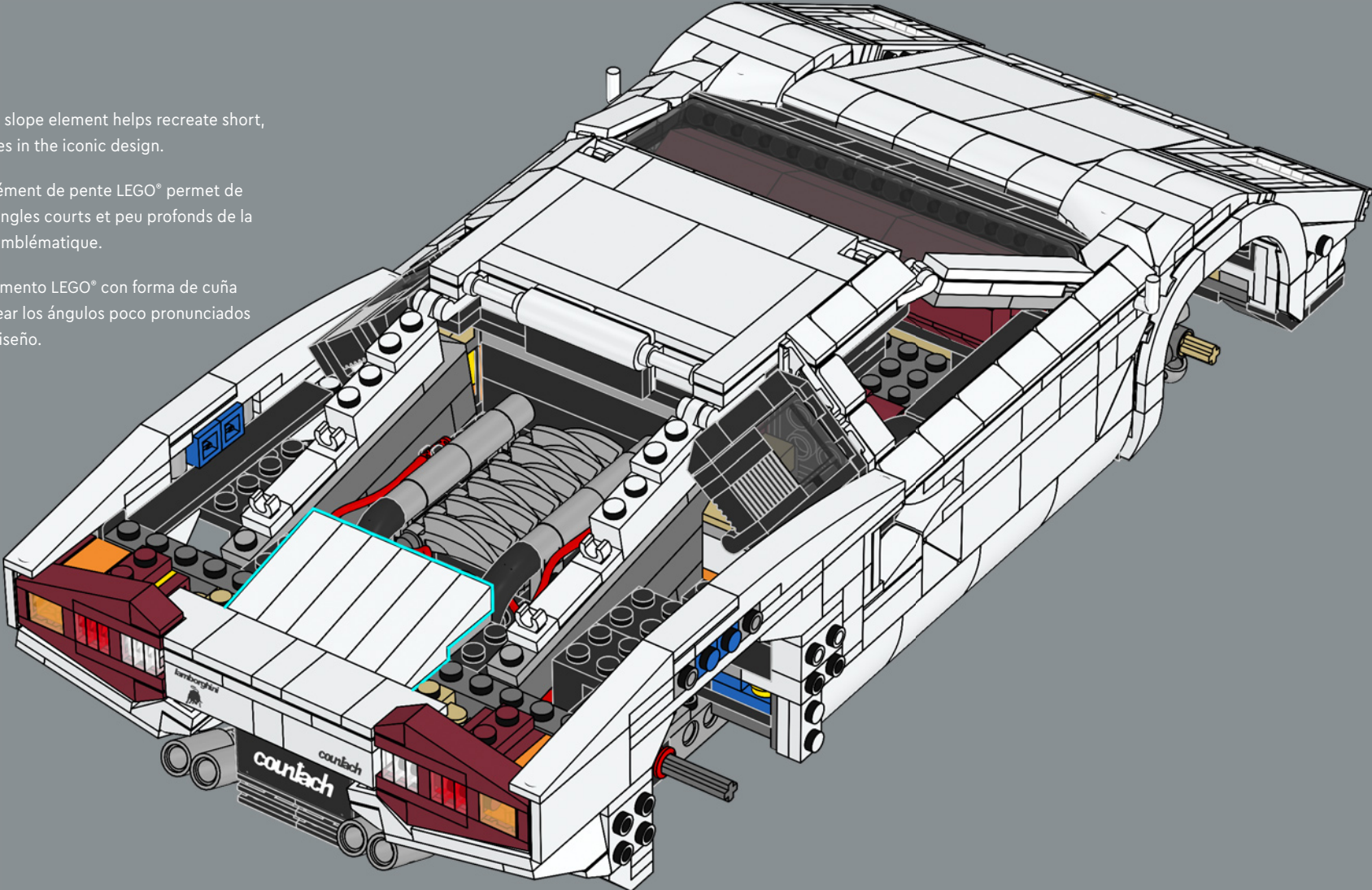



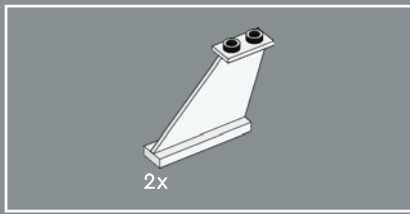

359

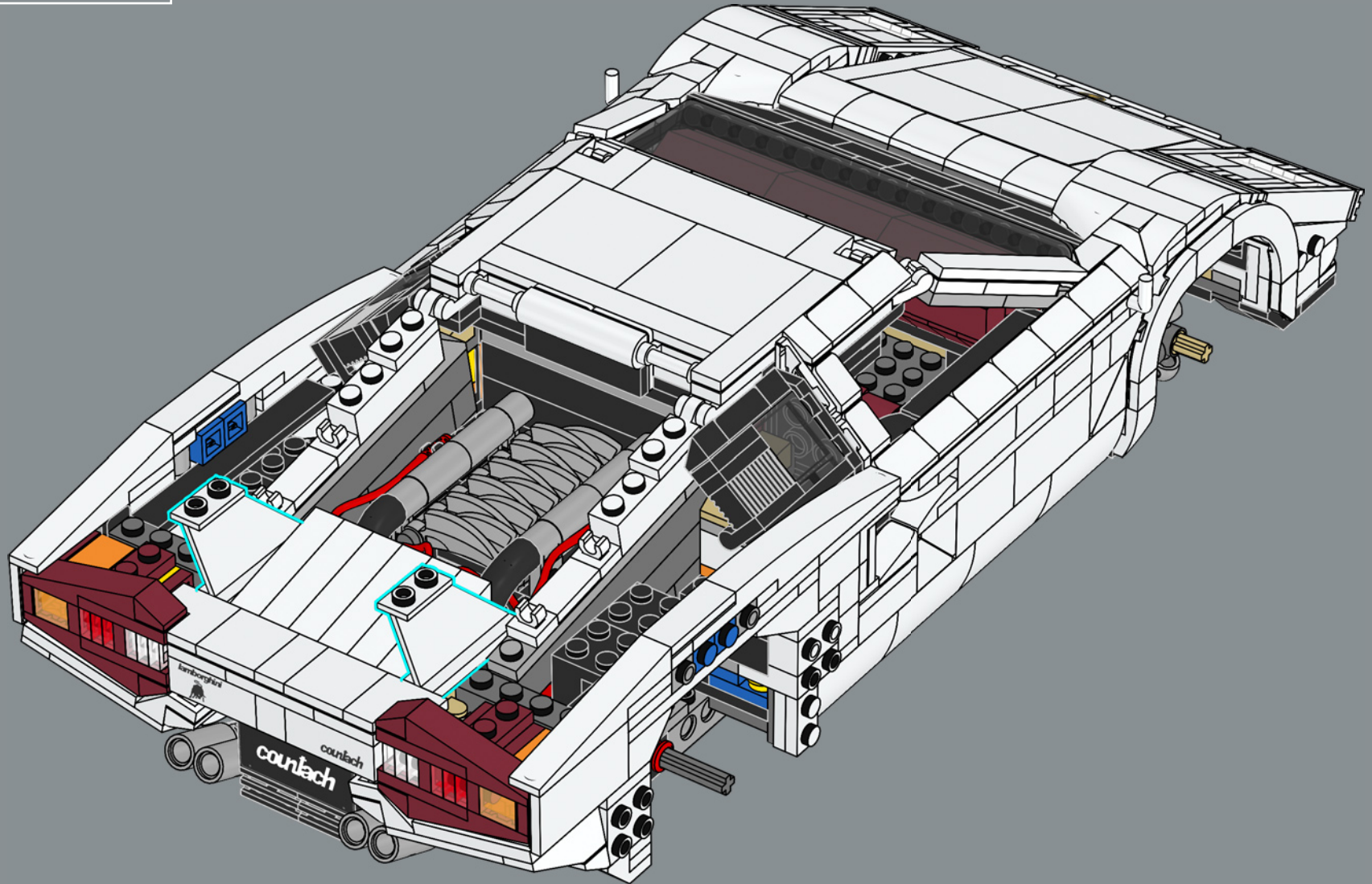



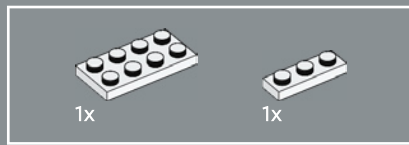
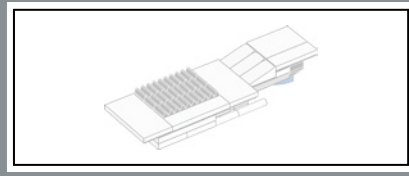
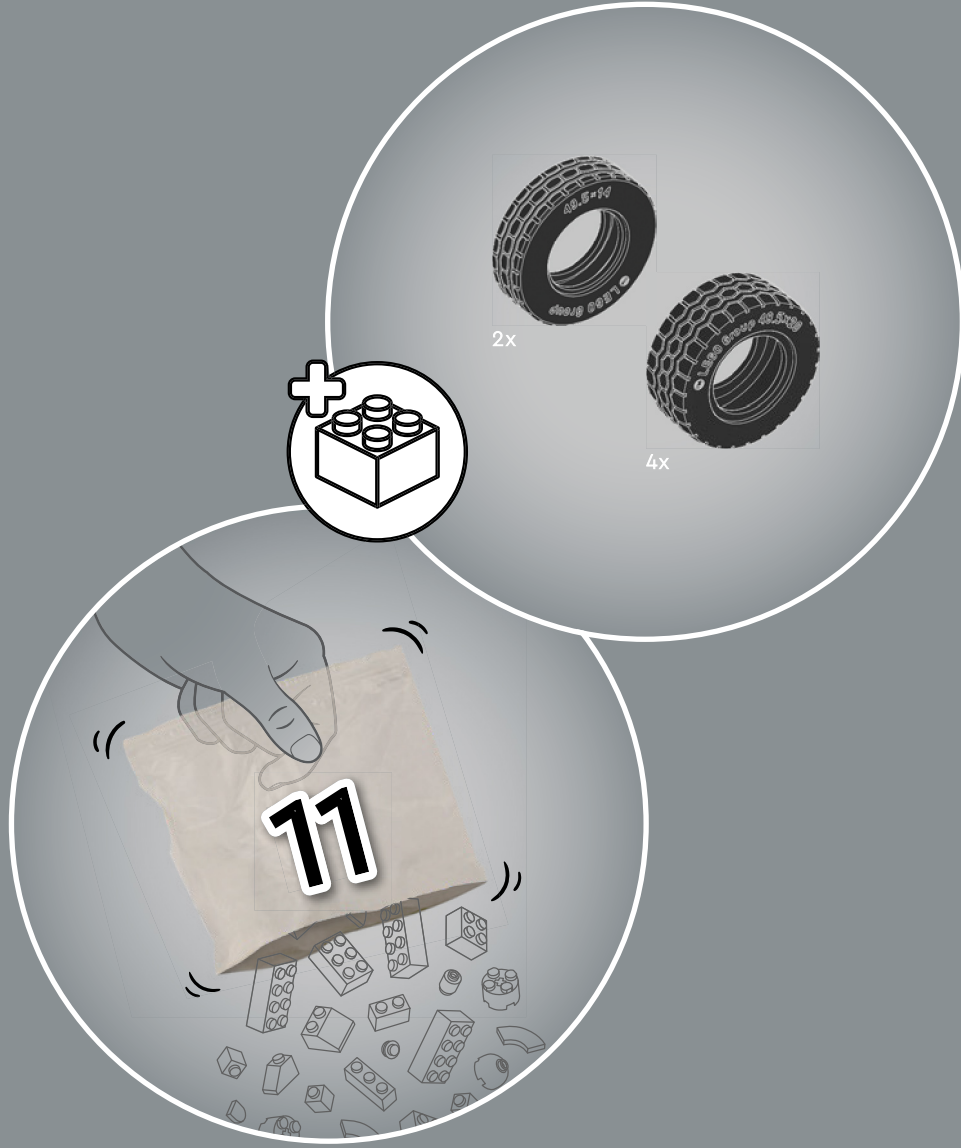

360

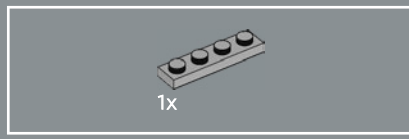
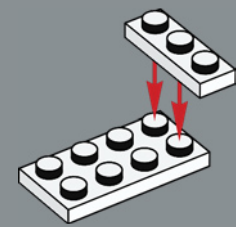

361

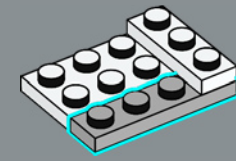



362

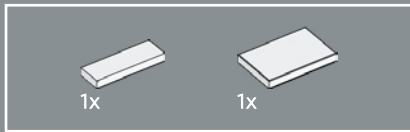
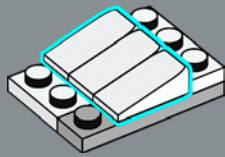

363

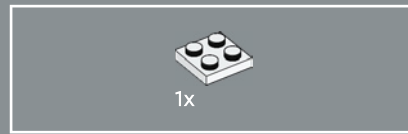
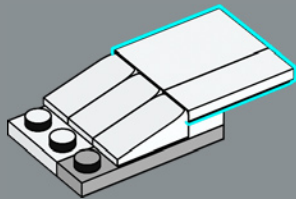
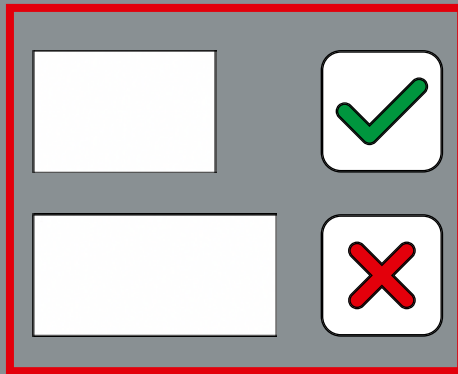

364

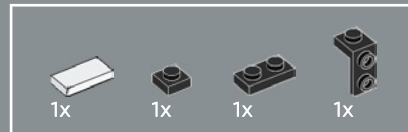
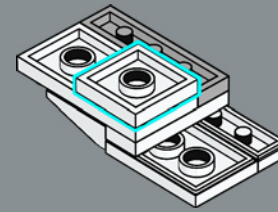

365

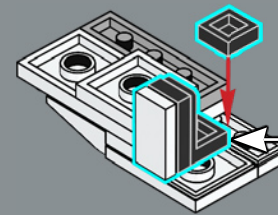
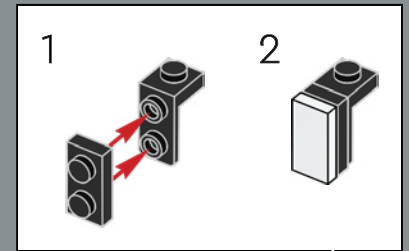



366

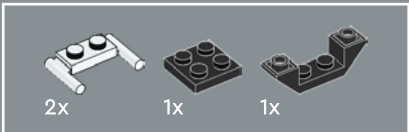
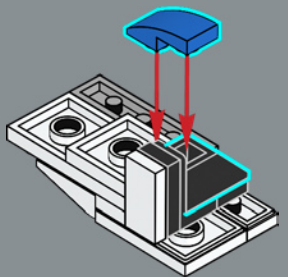

367

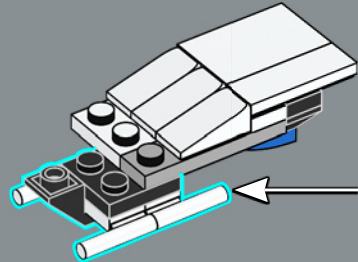
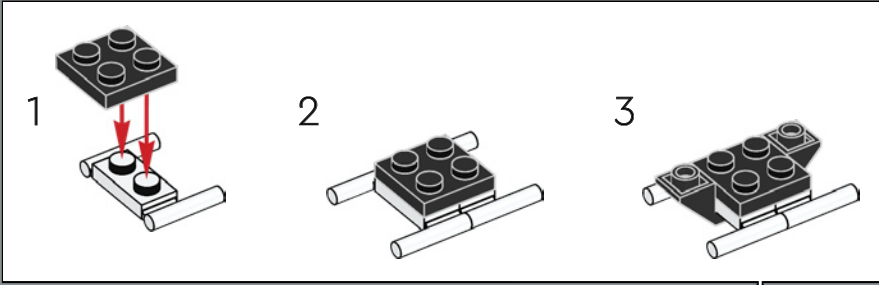



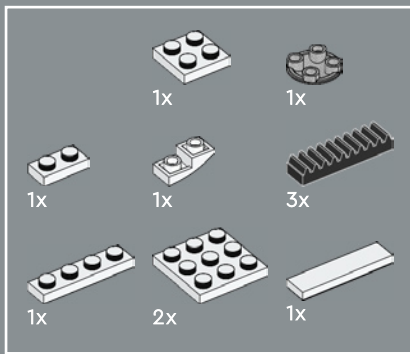

368

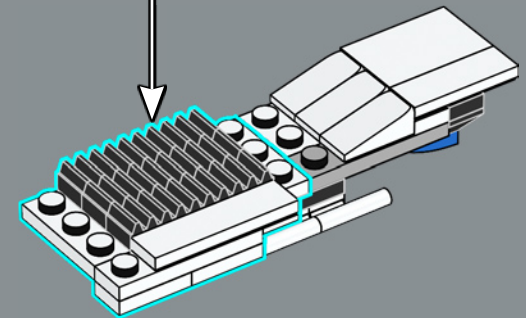
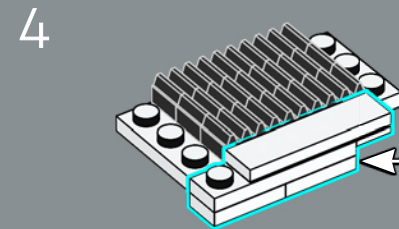
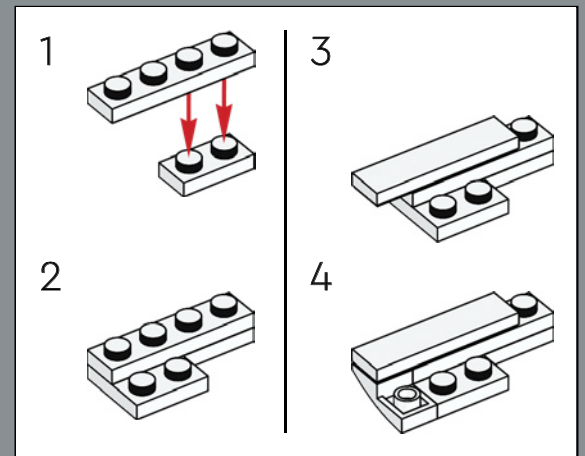
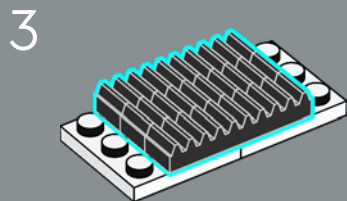
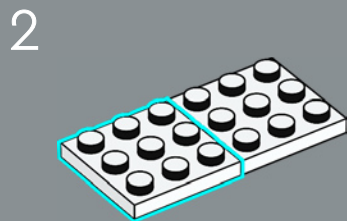
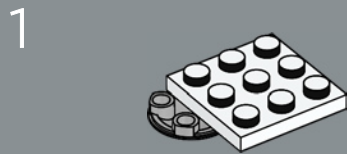

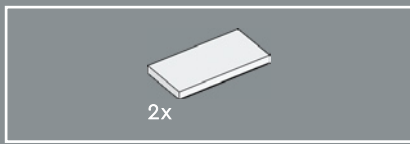

369

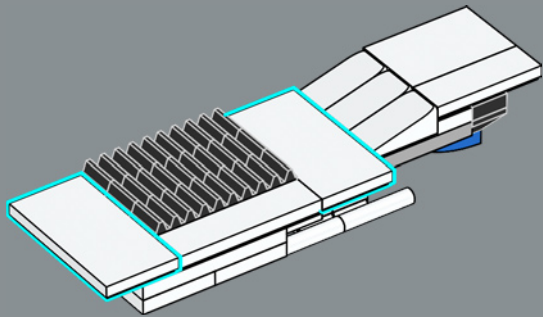
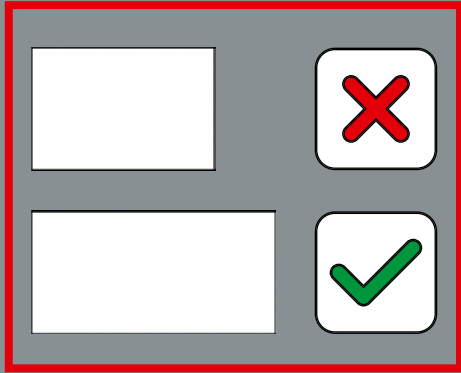

370

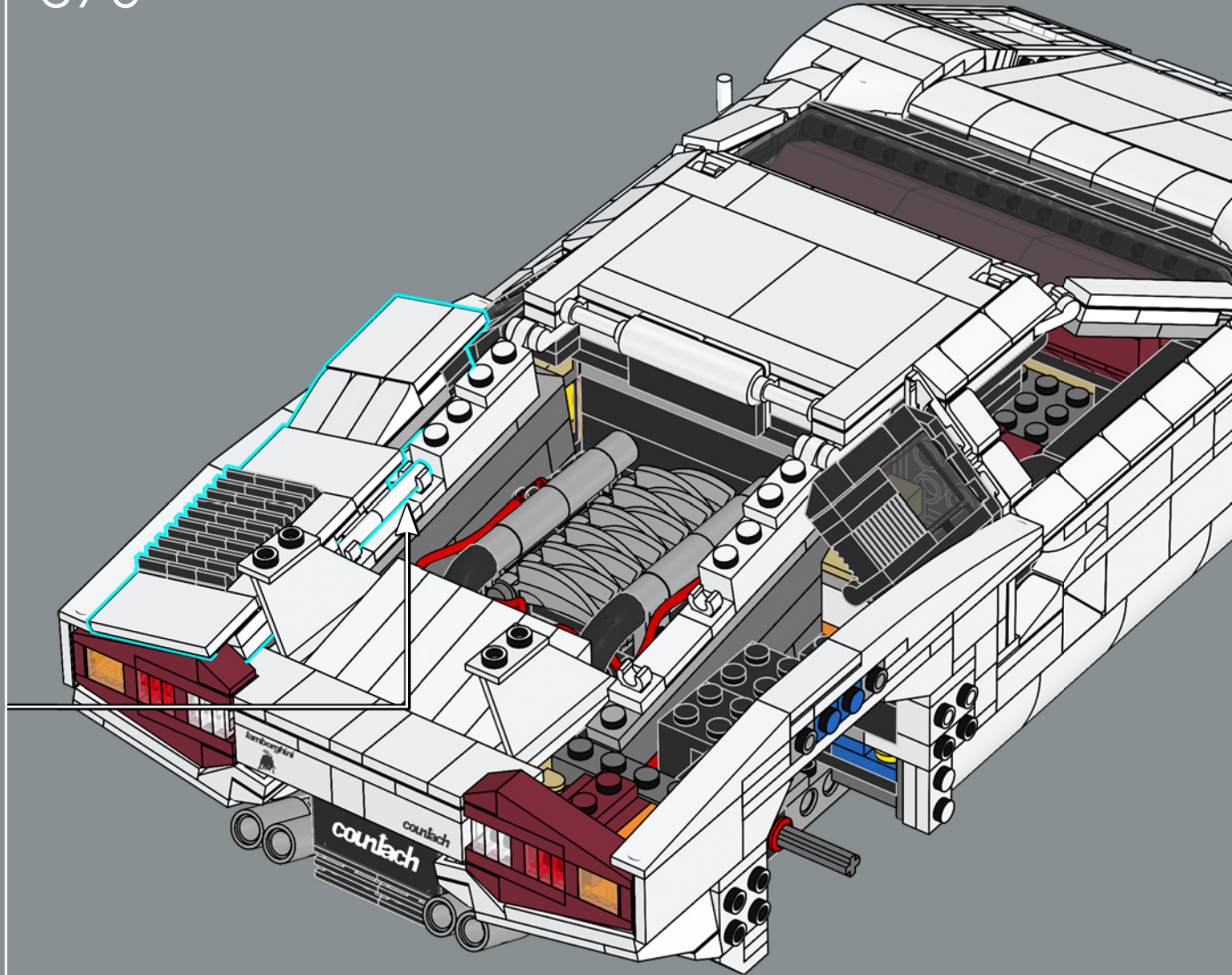

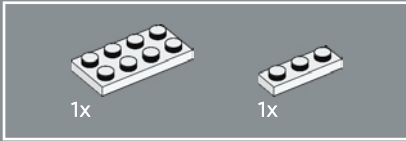
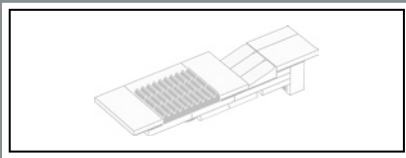

371

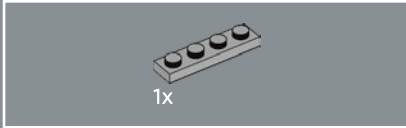
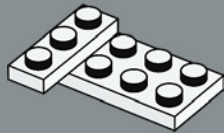

372

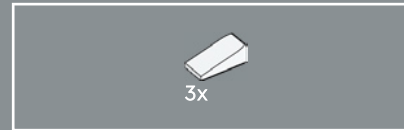
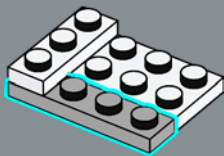

373

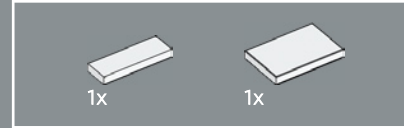
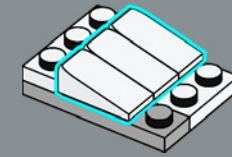

374

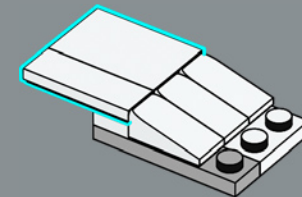
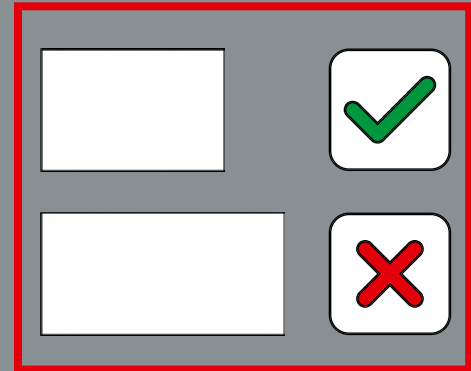



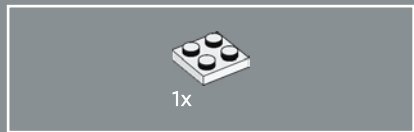

375

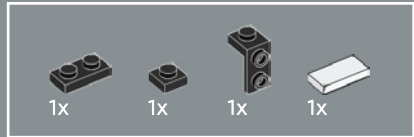
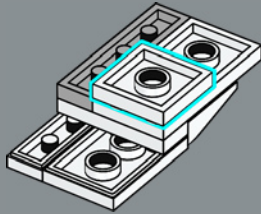

376

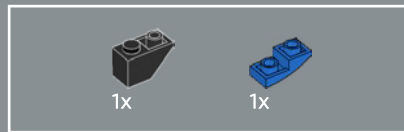
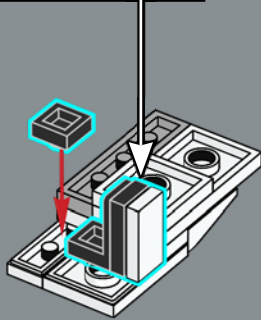
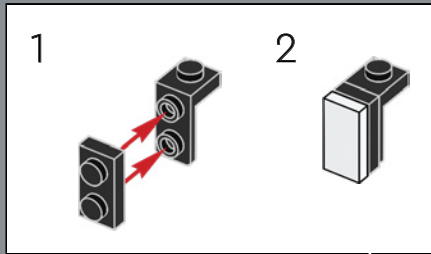

377

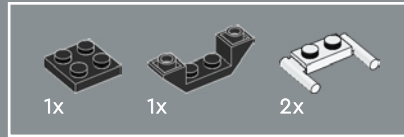
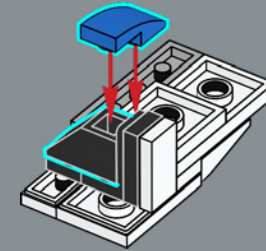

378

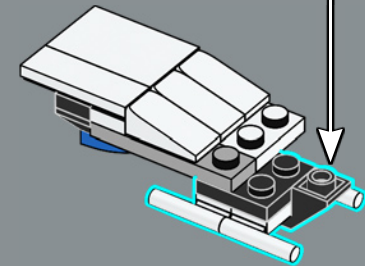
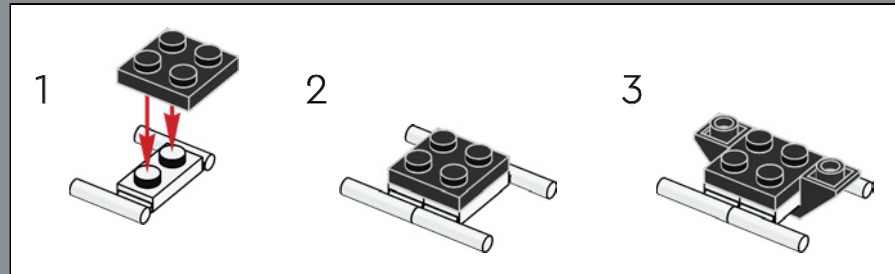

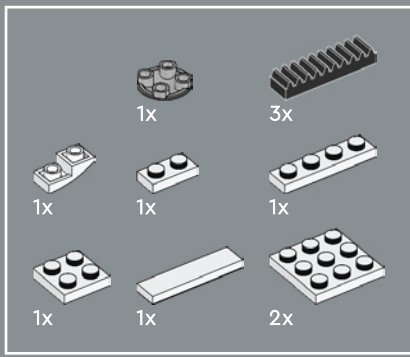

379

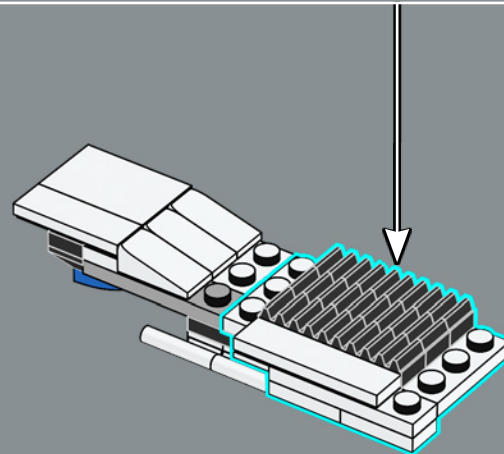
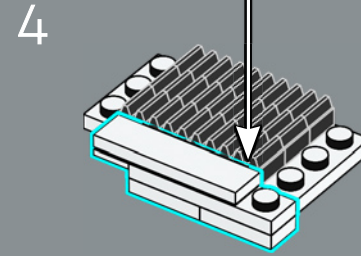
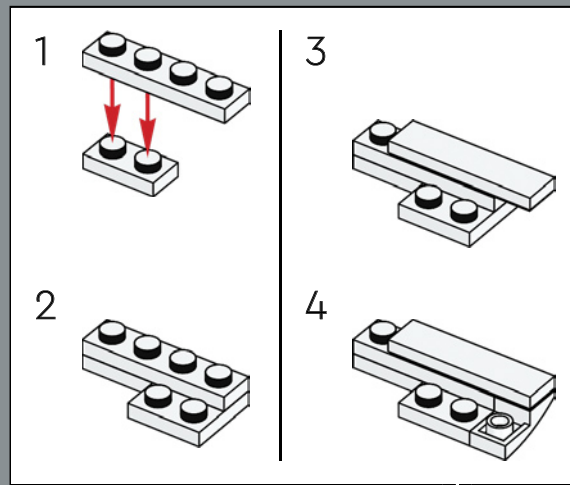
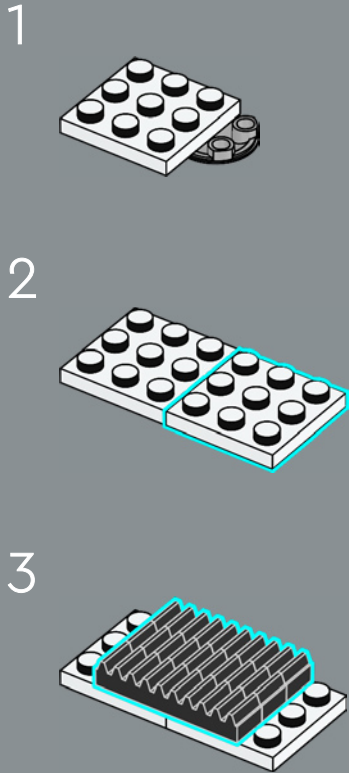

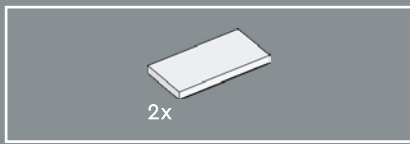

380

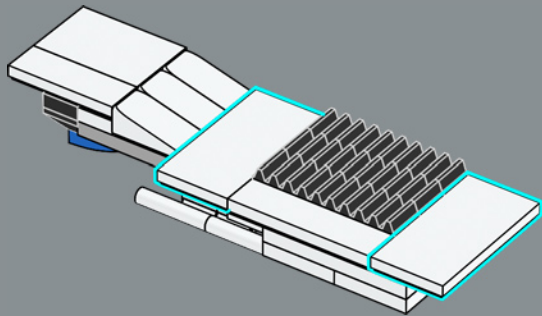
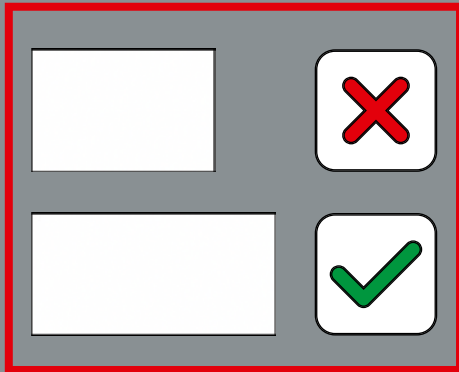

381

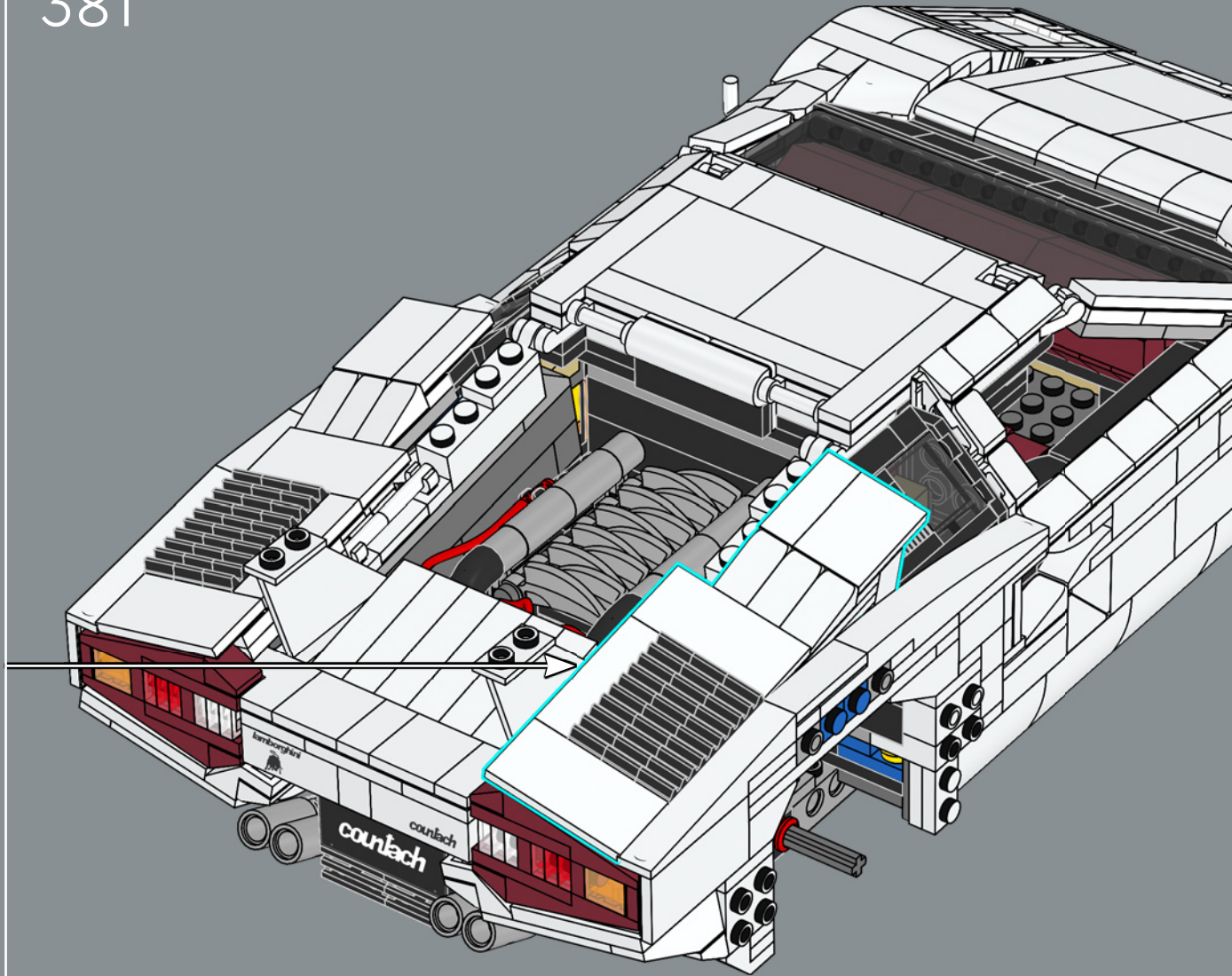



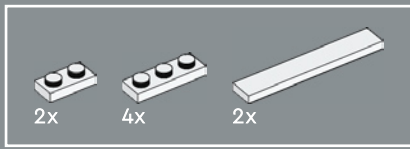

382

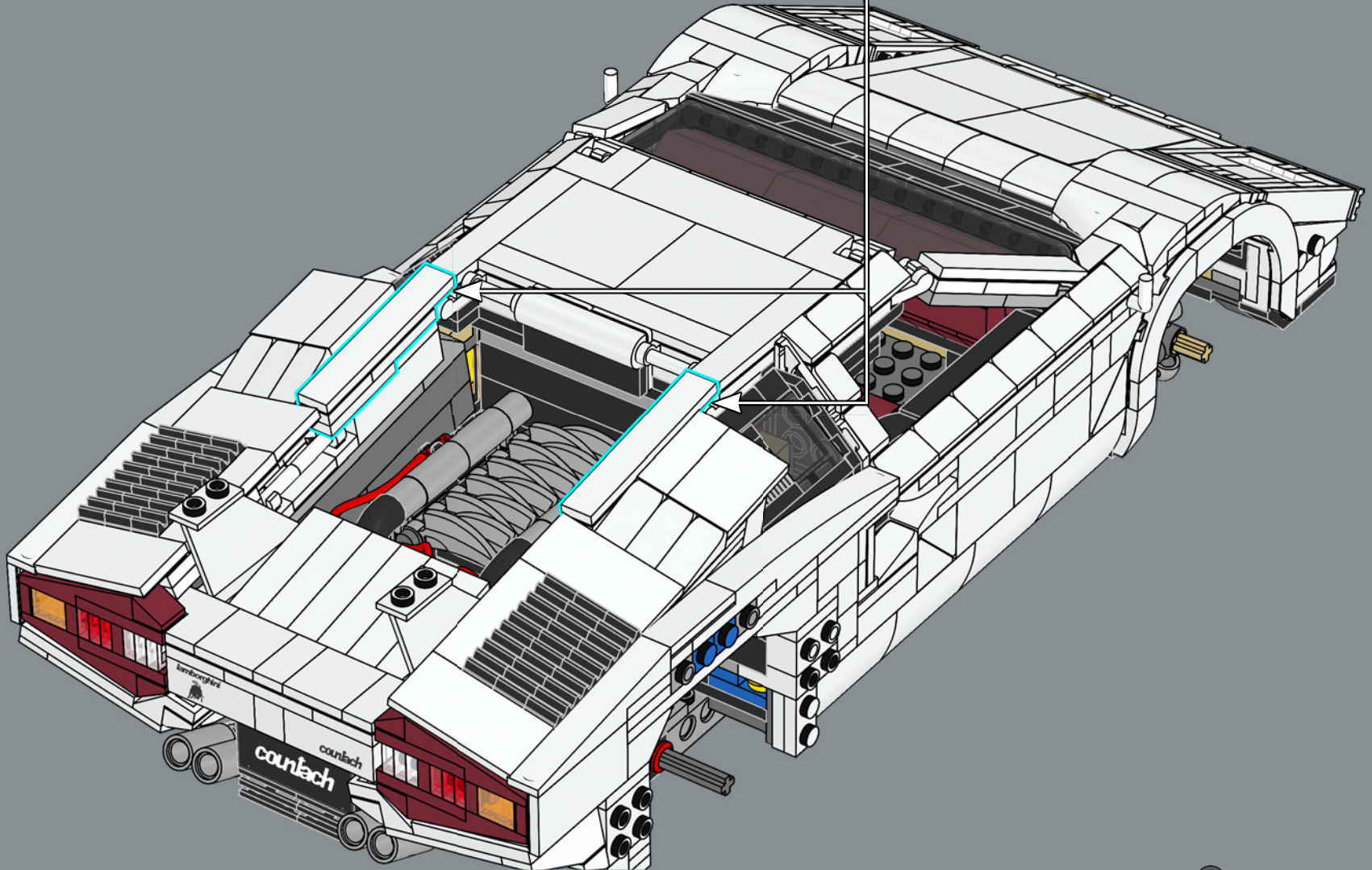
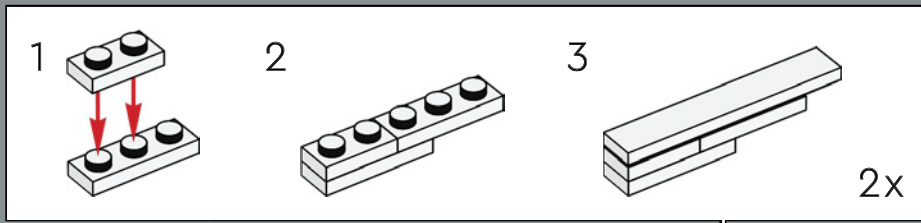

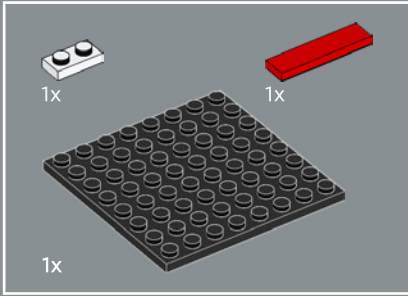
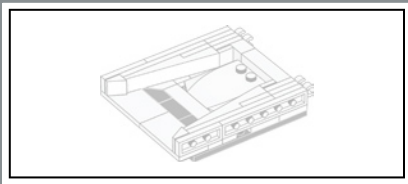

383

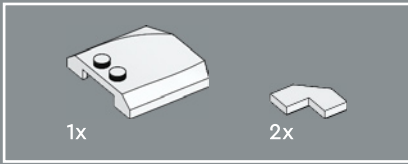
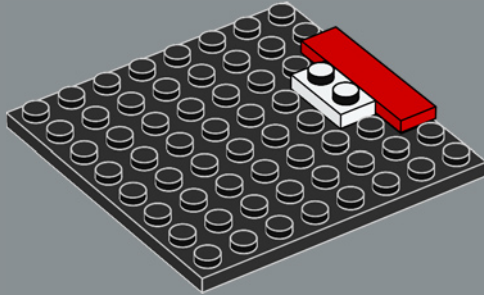

384

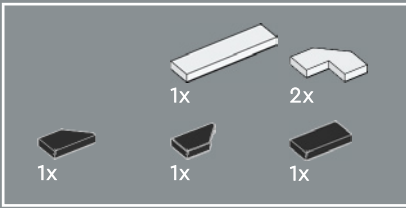
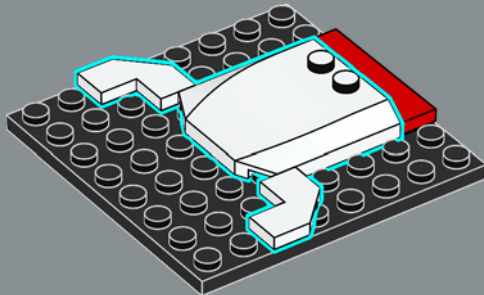

385

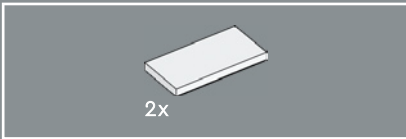
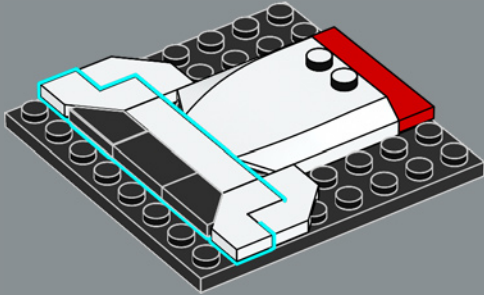

386

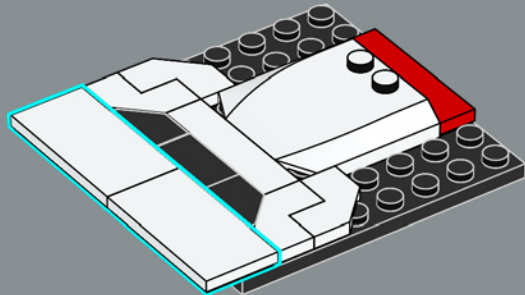

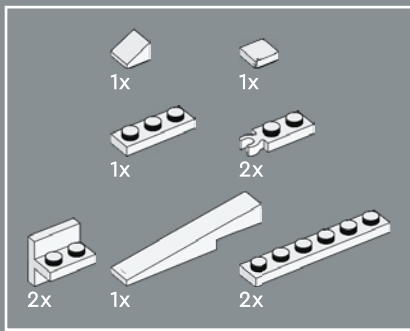

387

1

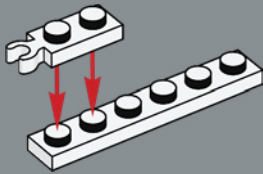

2

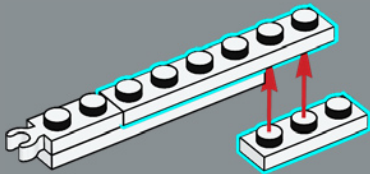

3

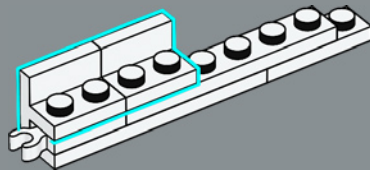

4

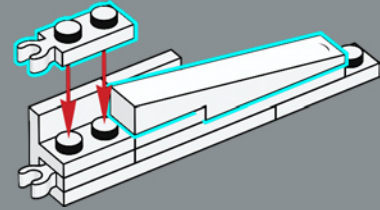

5

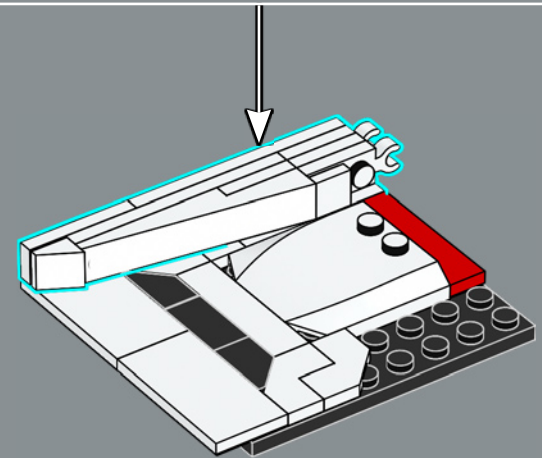
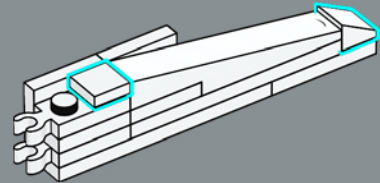



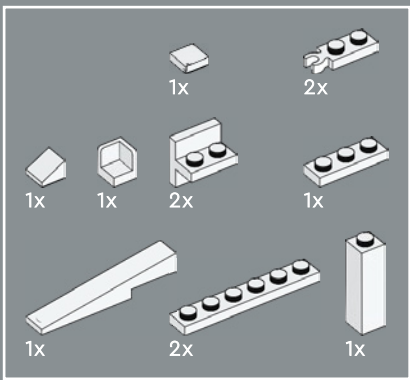

388

1

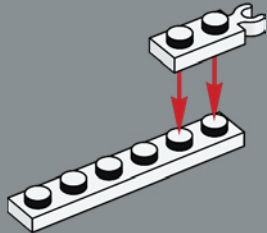

2

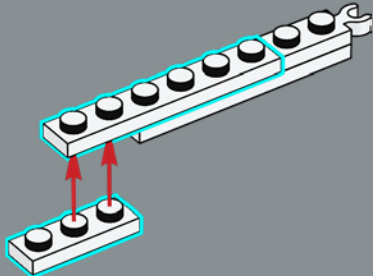

3

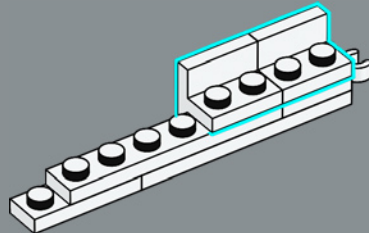

4

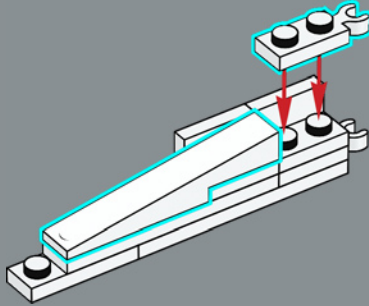

5

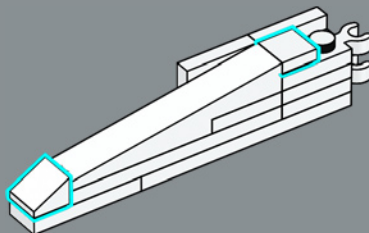

6

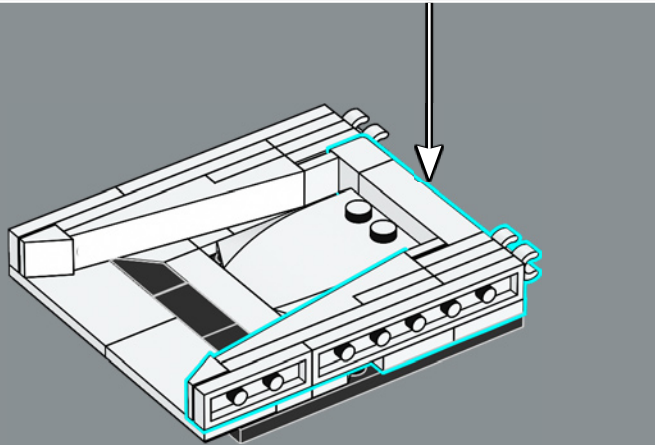
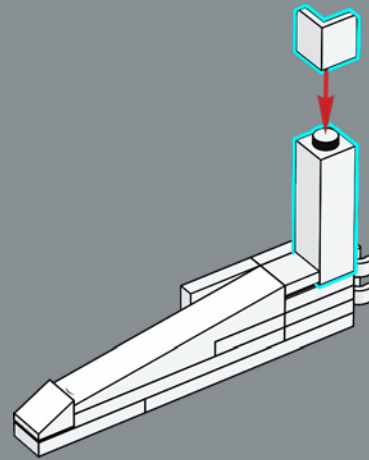

389

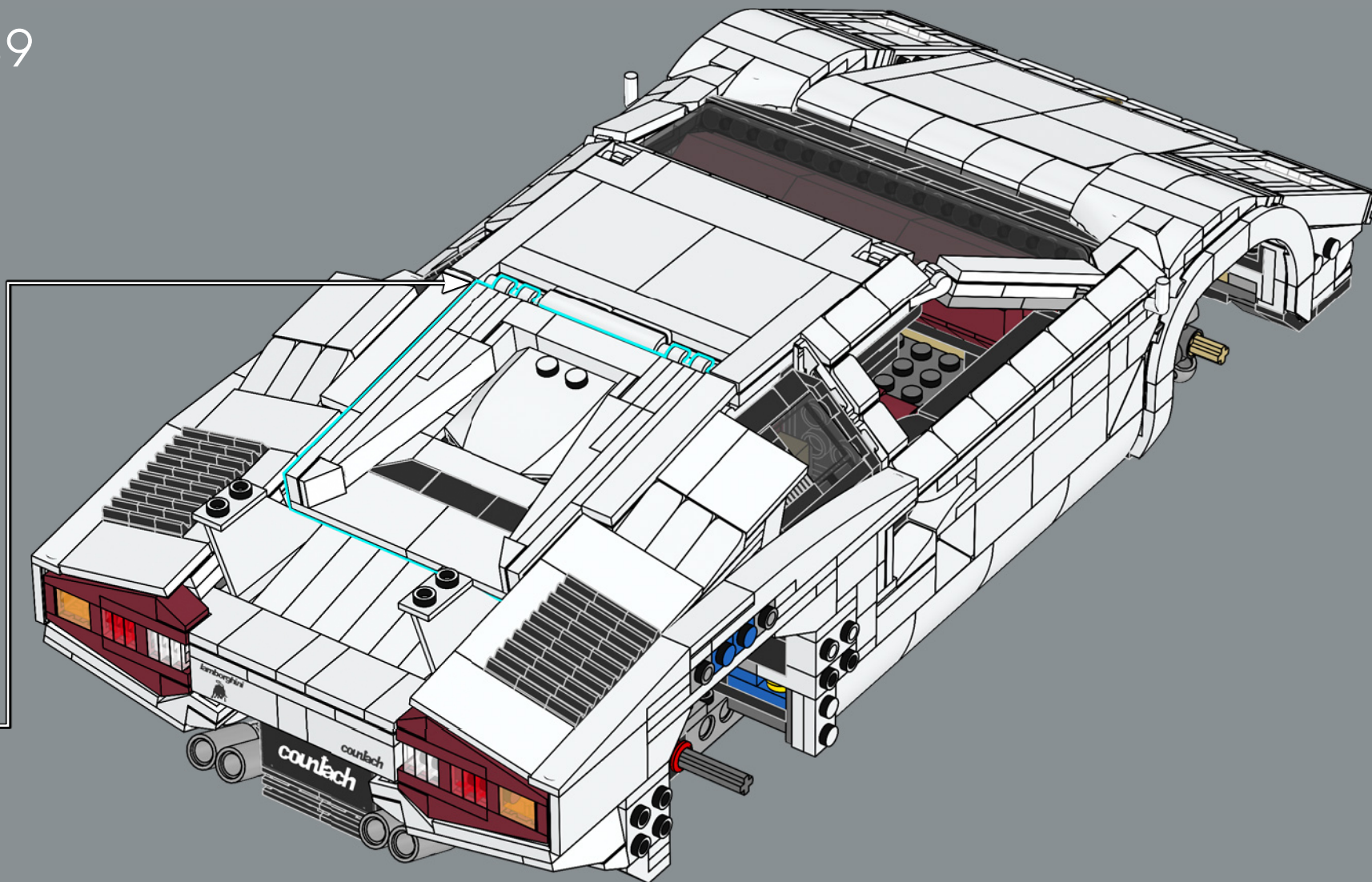

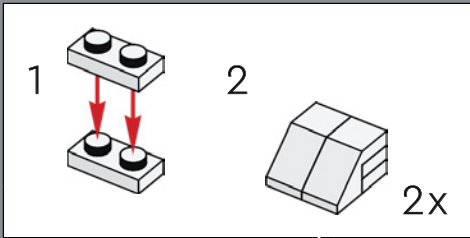
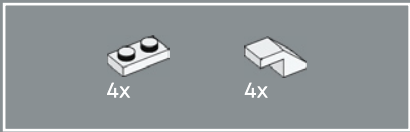

390

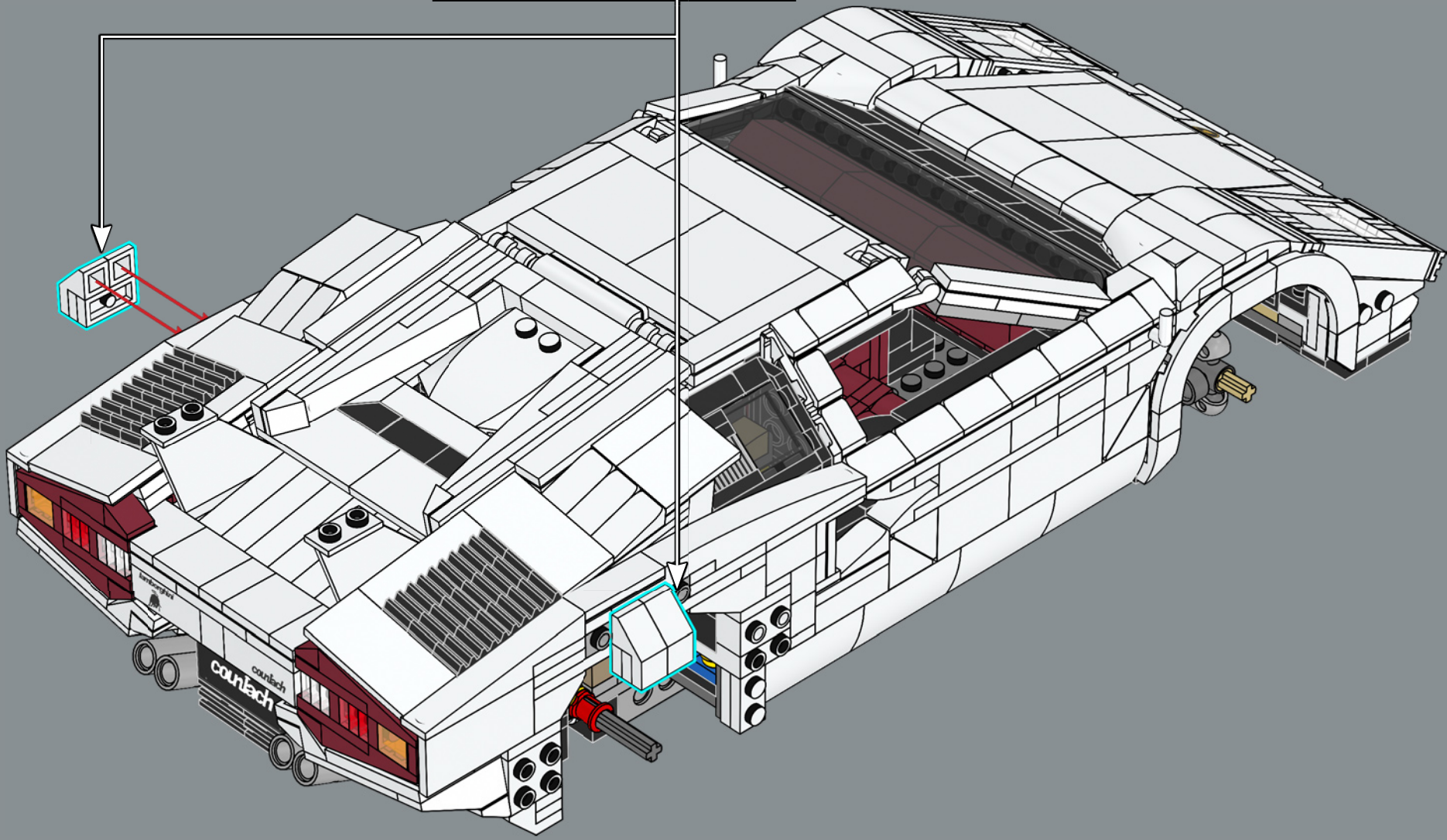





A new cone-shaped LEGO® element helps recreate the characteristic fender.

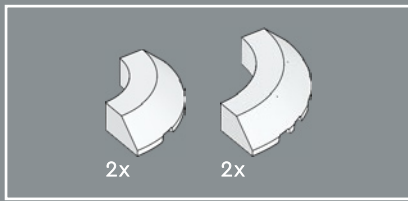

391

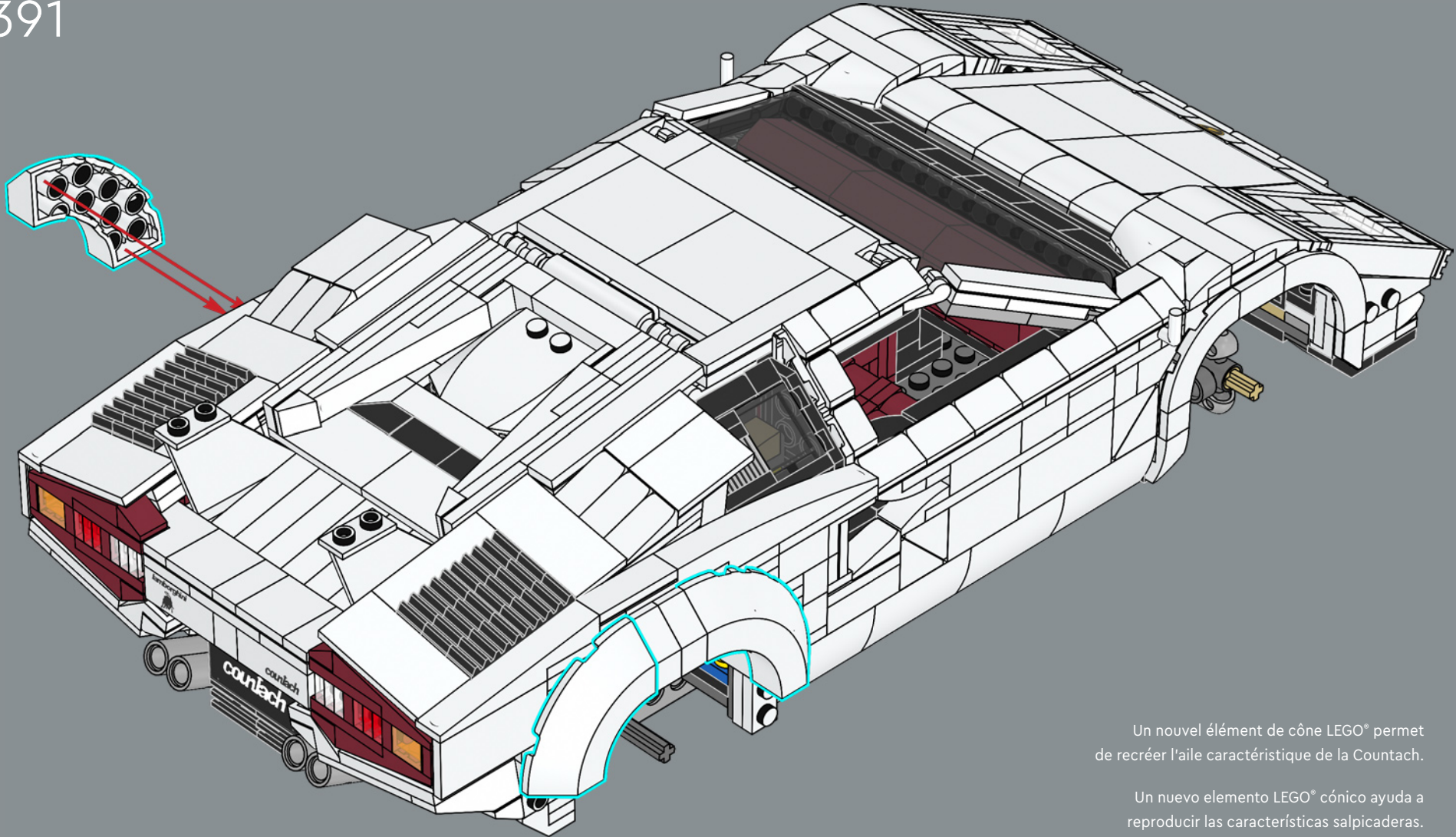

Un nouvel élément de cône LEGO® permet de recréer l'aile caractéristique de la Countach.

Un nuevo elemento LEGO® cónico ayuda a reproducir las características salpicaderas.





392

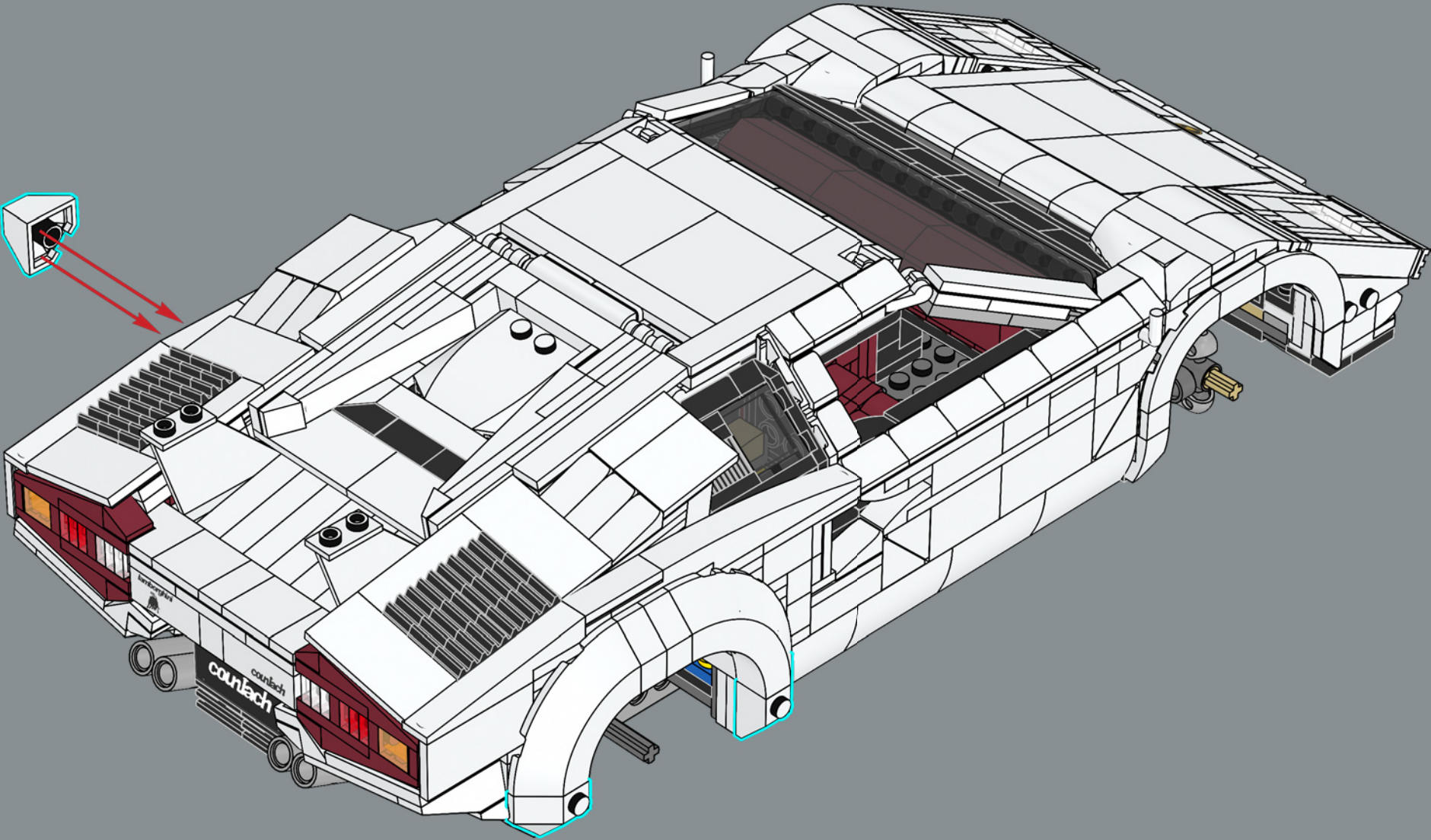

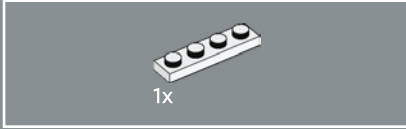
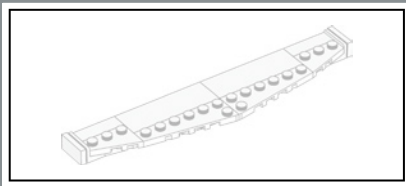

393

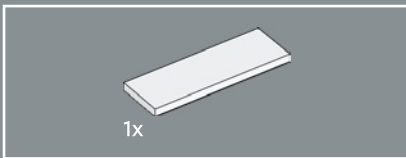

394

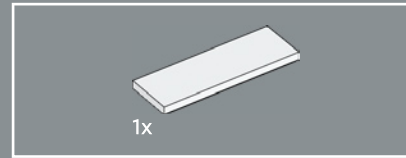
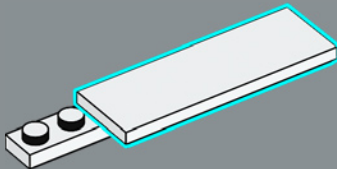

395

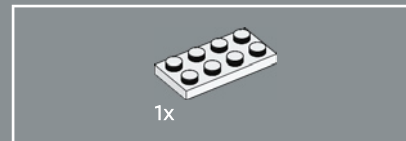
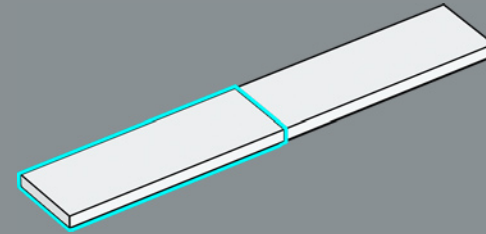

396

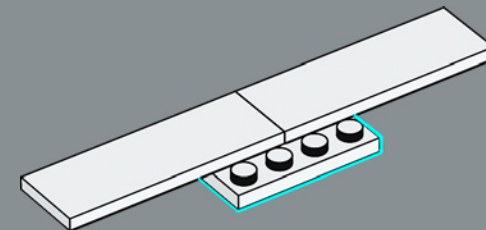



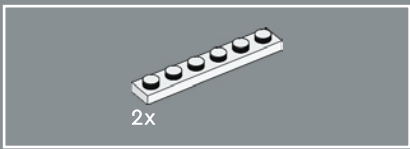

397

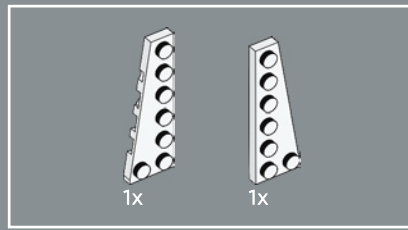
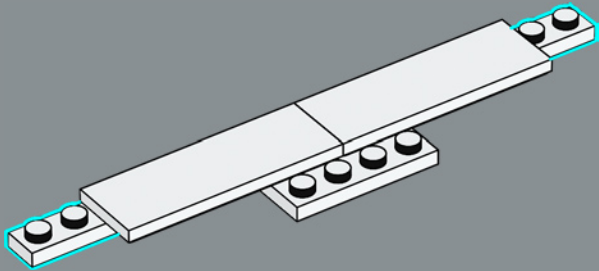

398

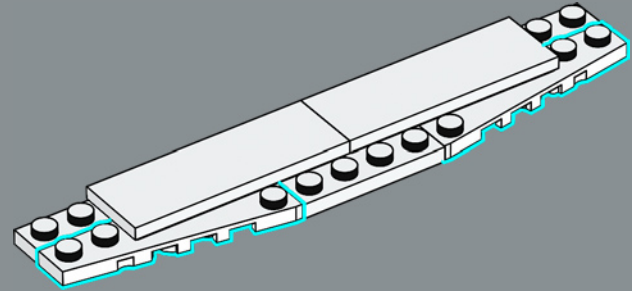

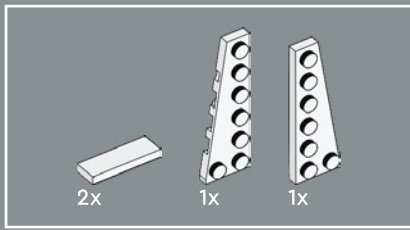

399

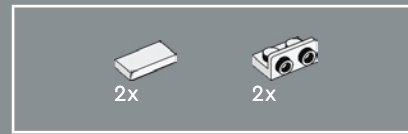
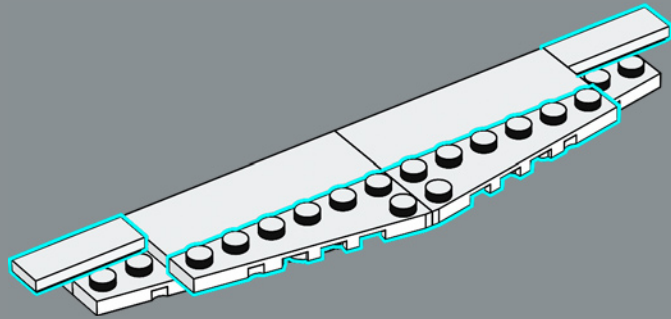

400

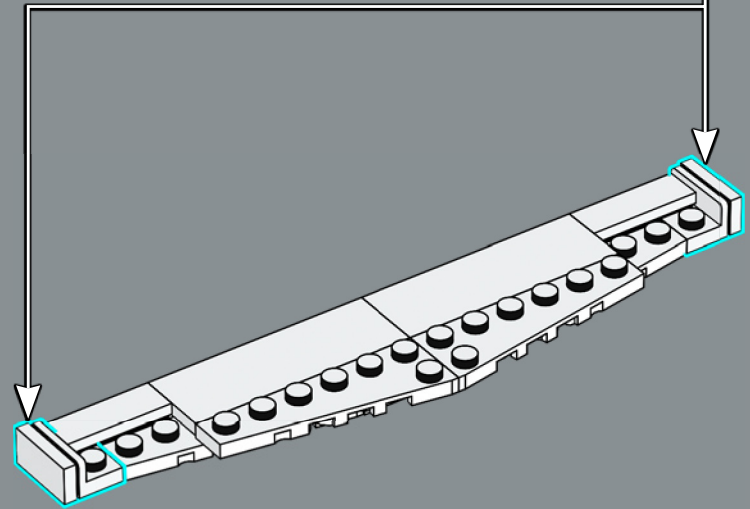
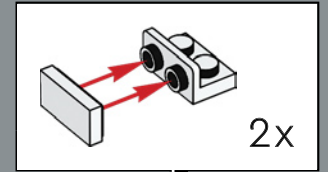

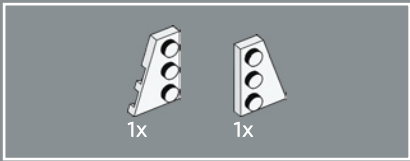

401

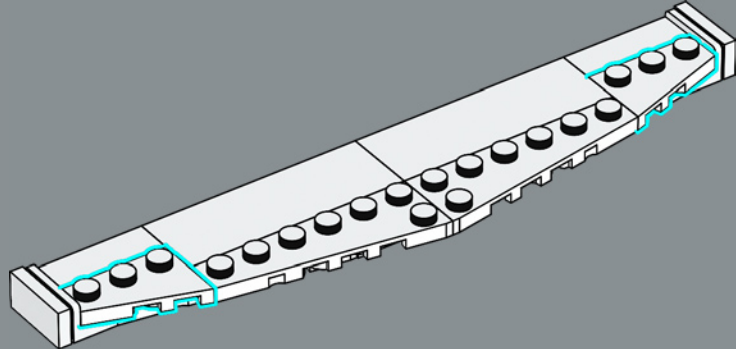

402

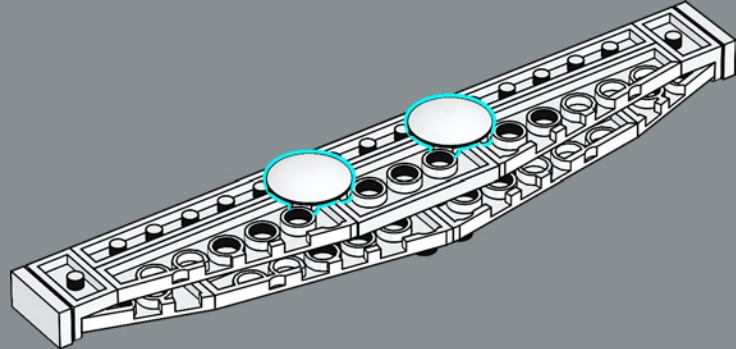



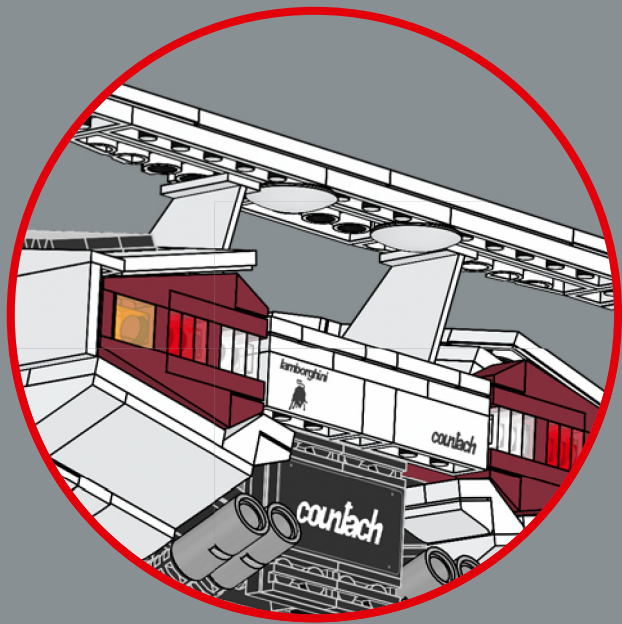

403

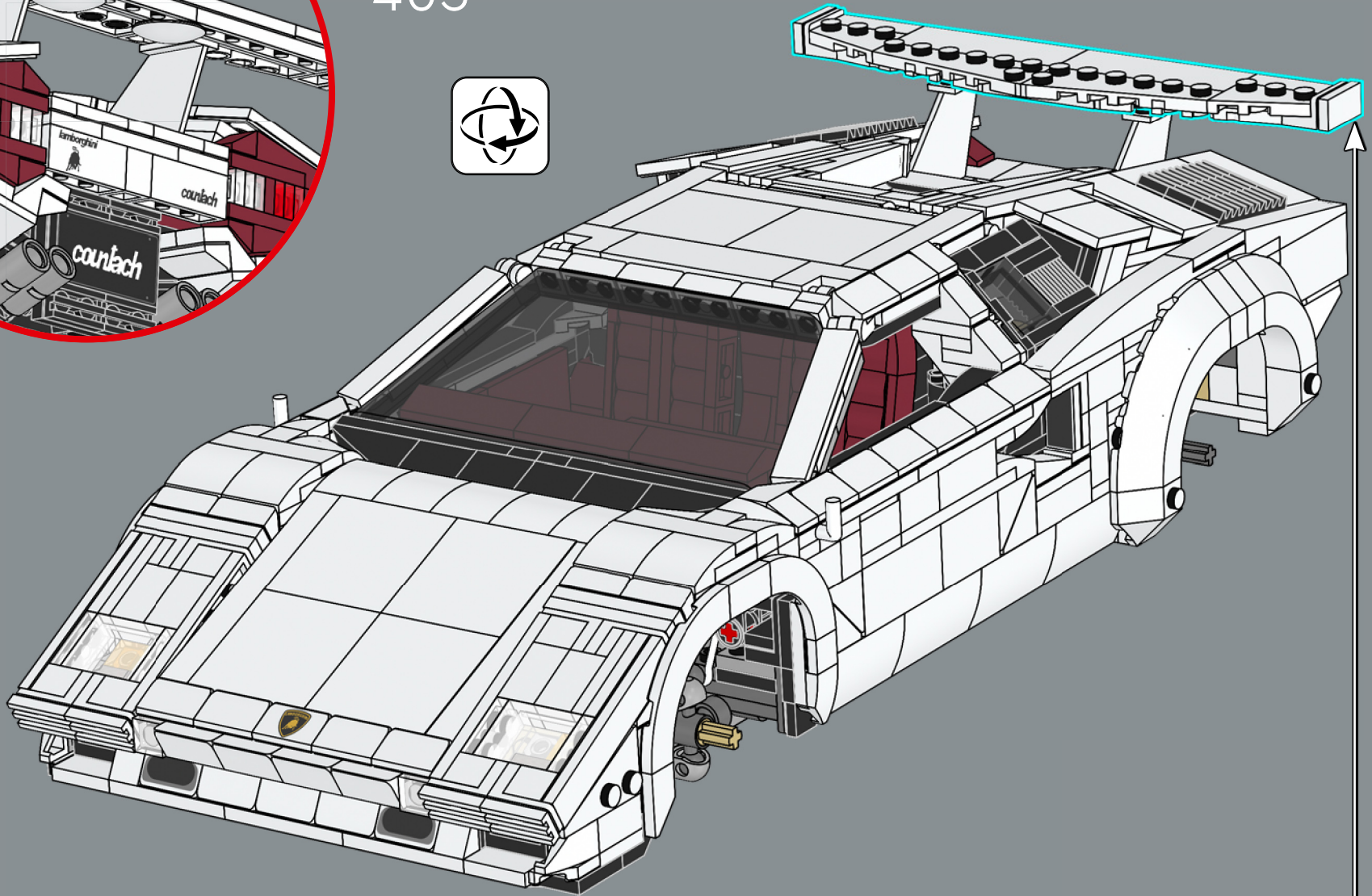

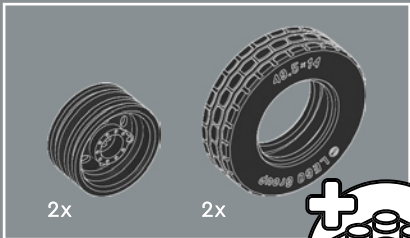

404

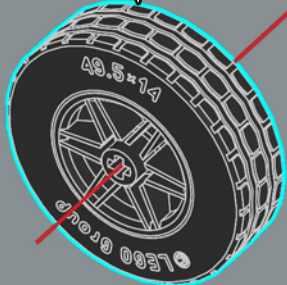
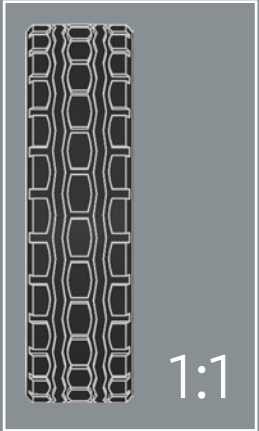
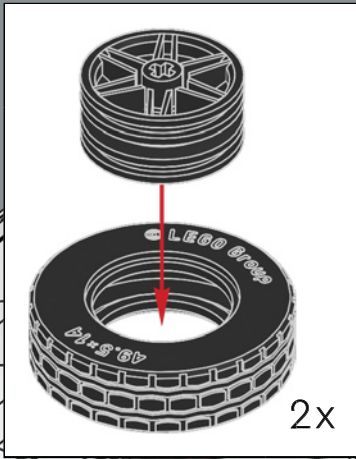
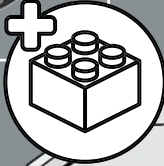



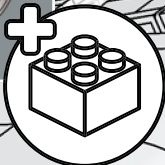
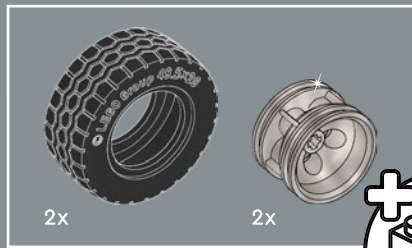

405

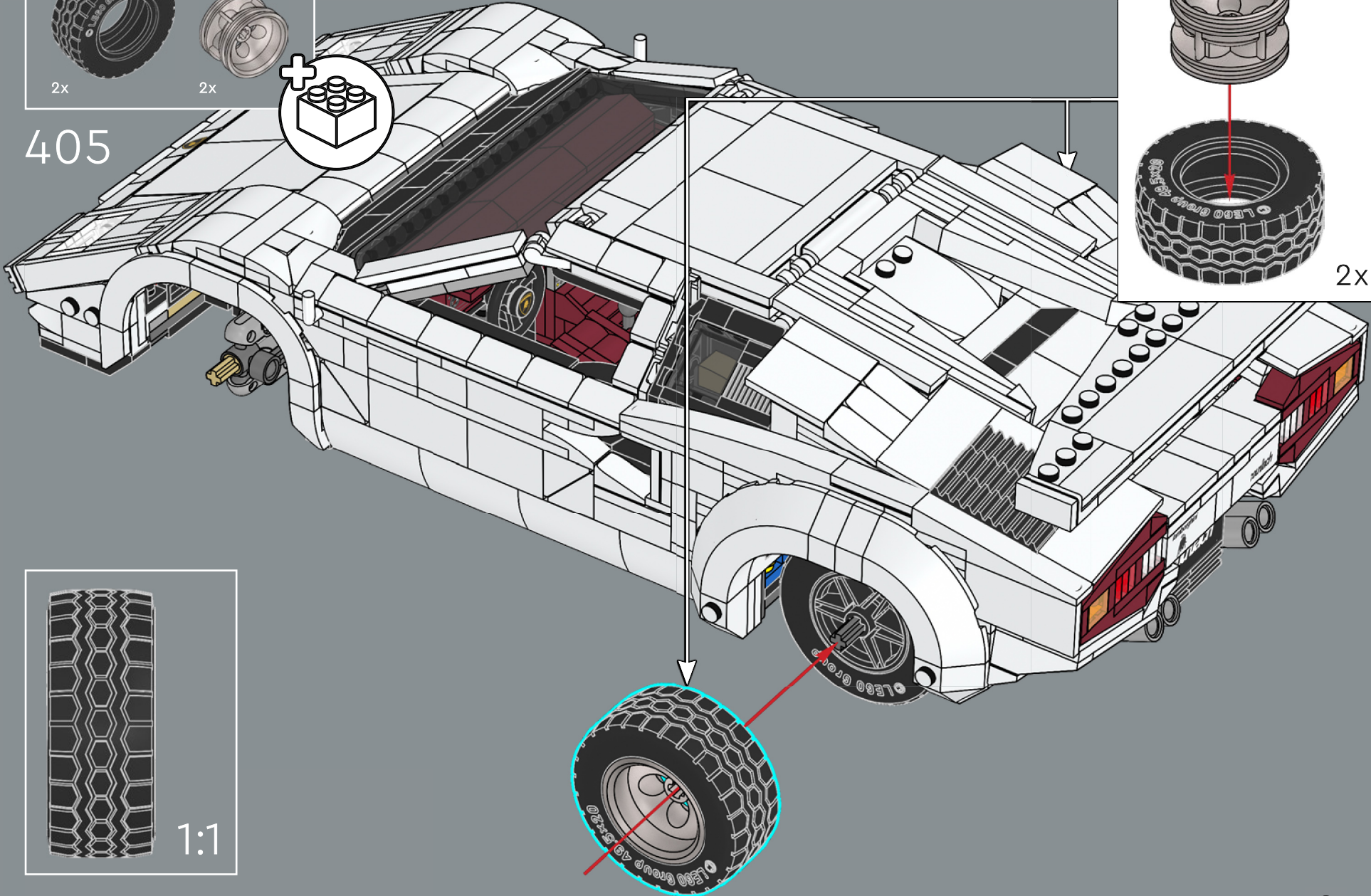
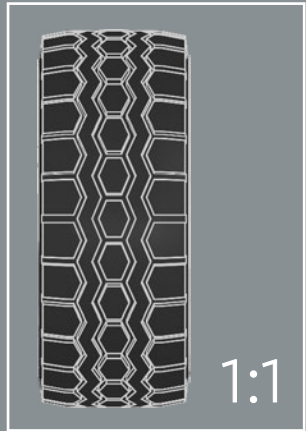
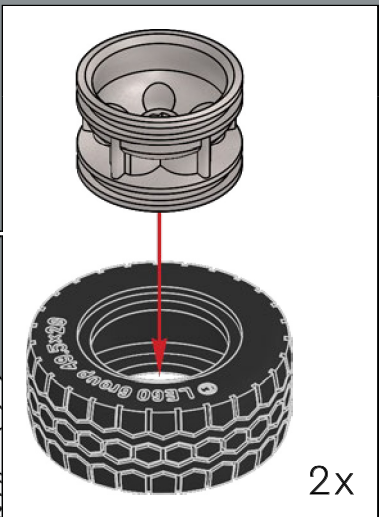





A new rim accommodates steering and a deep contour in the back wheels.

Une nouvelle jante épouse la direction et les contours profonds des roues arrière.

Un nuevo tipo de rin ofrece el espacio necesario para el sistema de dirección y hace posible reproducir fielmente las ruedas posteriores de huella ancha.

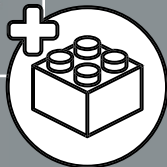
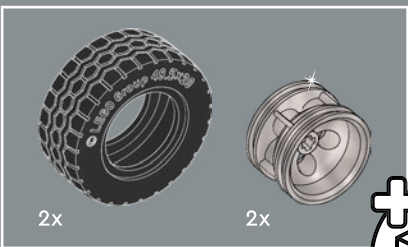

406

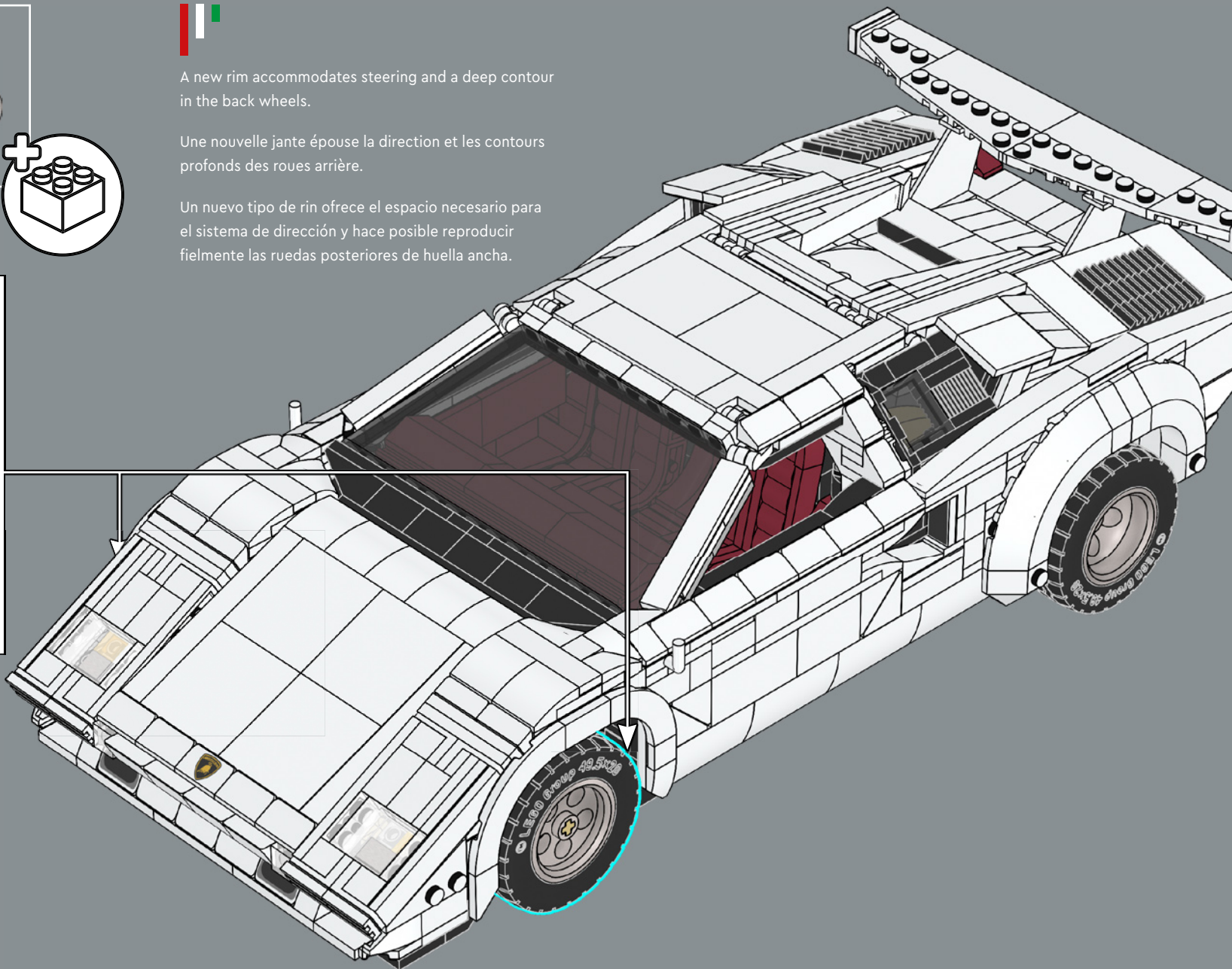
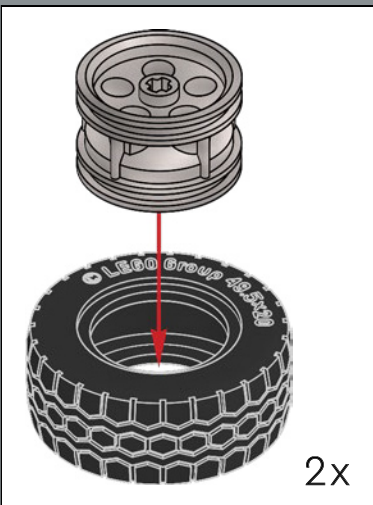

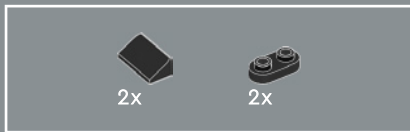

407

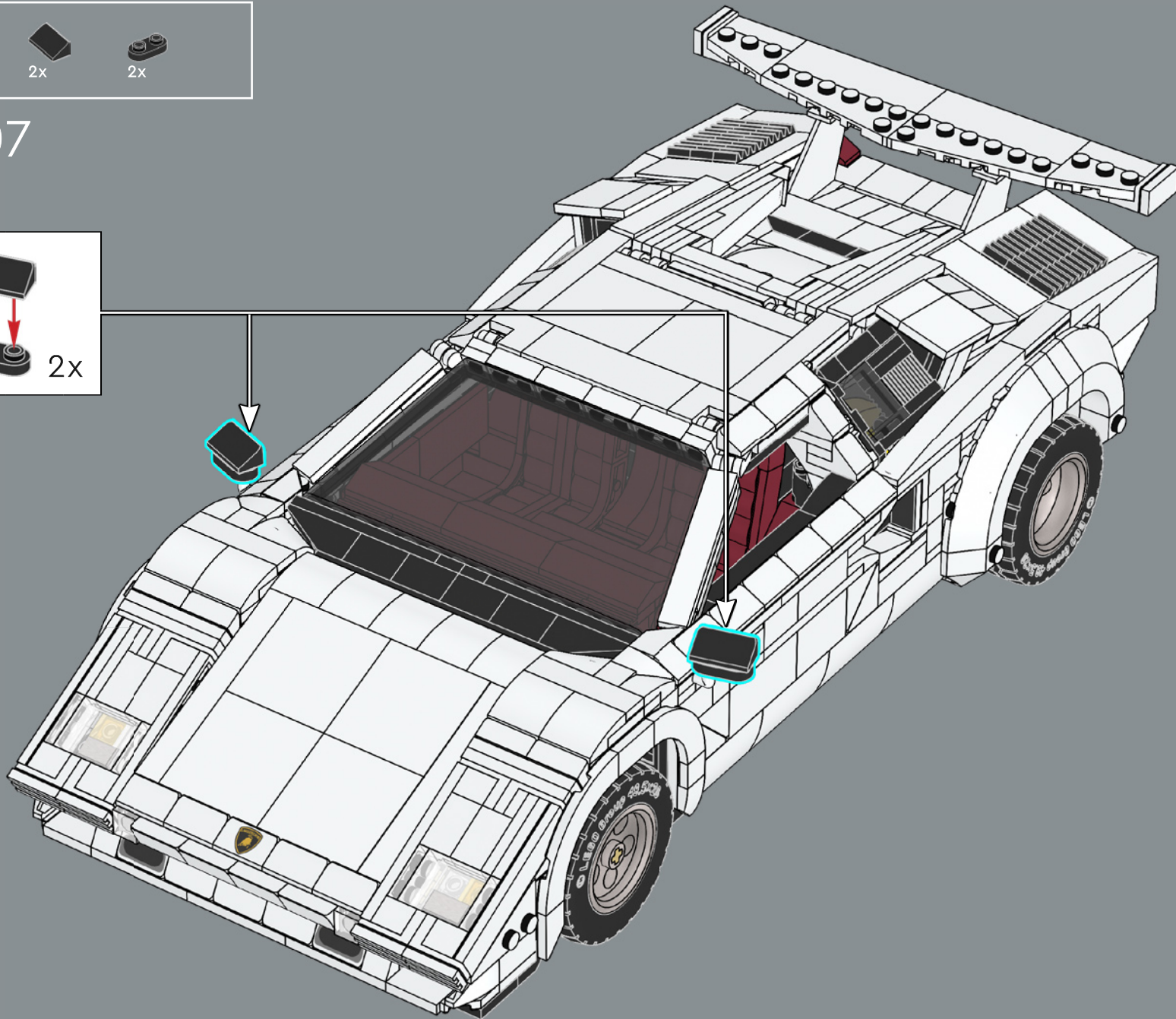
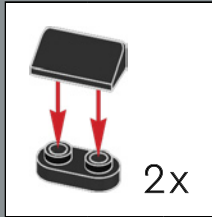



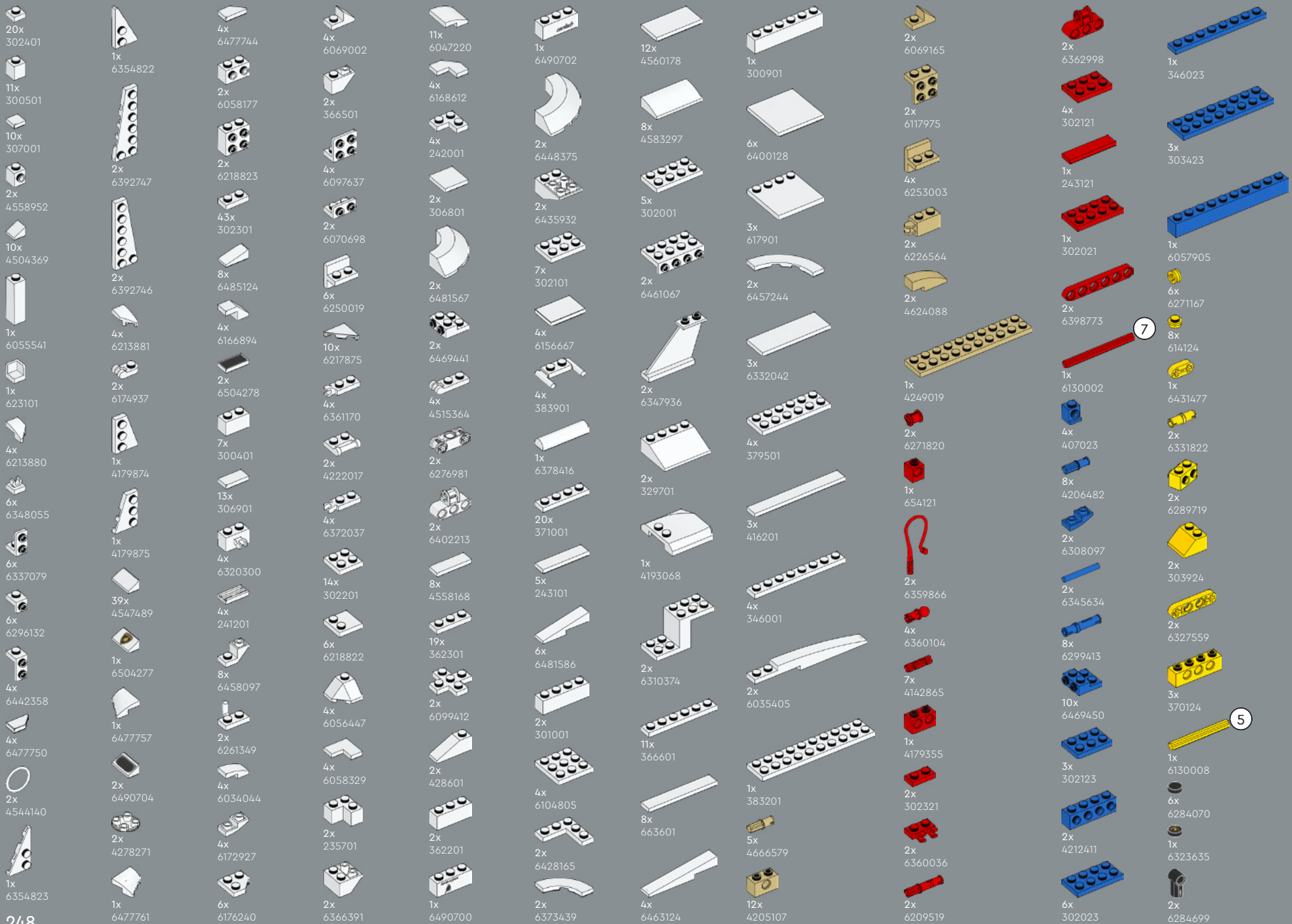



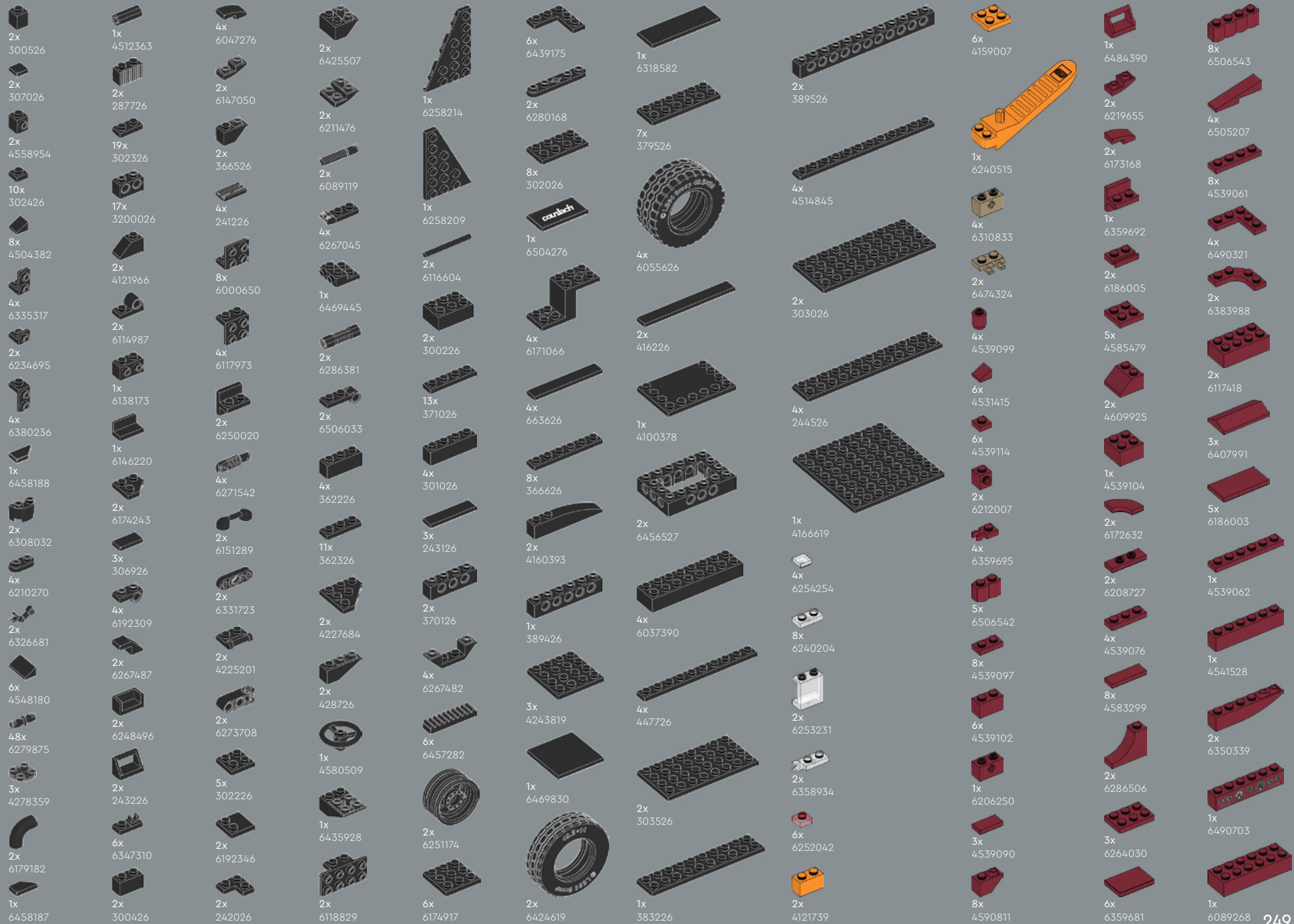

6x  
64448793

2x  
6284071

2x  
6308012

2x  
4211525

2x  
4278273

8x  
6173127

18x  
4211398

2x  
4211388

2x  
6326078

1x  
6329662

2x  
4593679

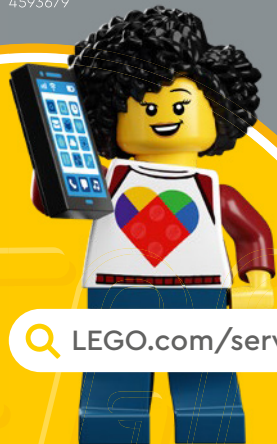

[LEGO.com/service](https://www.LEGO.com/service)

2x  
4211469

2x  
6093859

2x  
6301870

4x  
4244627

12x  
6359723

4x  
6326478

3x  
4211397

2x  
4211353

2x  
4211815

2x  
4211881

3

2x  
6043639

6x  
6438836

4x  
4211429

8x  
4211396

4x  
4211445

4x  
6247352

1x  
4211395

2x  
4211549

1x  
4211452

2x  
4211425

1x  
4211404

1x  
4211406

5x  
4251149

1x  
4211462

4x  
6421513

2x  
4211360

1x  
6335319

1x  
6376639

2x  
6240550

2x  
6254252

1x  
4490599

8x  
6287672

2x  
6343854

4x  
6481570

2x  
6217492

2x  
6469858

2x  
4210633

2x  
6395635

2x  
4211044

2x  
4211098

6x  
6225494

1x  
6221607

4x  
6261374

2x  
6349479

2x  
6168776

2x  
6435267

5x  
6117972

2x  
6359227

6x  
6146321

2x  
6123814

2x  
4218696

4x  
6047417

3x  
6364352

2x  
6015356

4x  
4652259

4x  
4211068

2x  
4211104

8x  
6118832

1x  
6083620

2x  
4211103

4x  
4210686

2x  
4629920

4

2x  
4508553

1x  
4211002

2x  
4211107

1x  
4211061

4x  
4210794

2x  
4210783

1x  
4210796

1x  
6490496



# YOU COULD WIN



## YOU COULD WIN

Your feedback will help shape the future development of this product series.

Visit:

## DU KÖNNTEST GEWINNEN

Dein Feedback trägt zur Weiterentwicklung dieser Produktreihe bei.

Geh auf:

## VOUS POURRIEZ GAGNER

Vos commentaires nous aideront à concevoir les futurs produits de cette gamme.

Visitez :

## POTRESTI VINCERE TU

La tua opinione ci aiuterà a migliorare la creazione futura di questa linea di prodotti.

Visita:

## PUEDES GANAR

Tu opinión contribuirá al futuro de esta serie de productos.

Visita:

## 轻松获奖

您的反馈将有助于我们在今后改进本产品系列。

请访问:

---

[LEGO.com/productfeedback](https://LEGO.com/productfeedback)

---

You also have the chance to win a LEGO® set.

Terms and conditions apply.\*

Außerdem hast du die Chance, ein LEGO® Set zu gewinnen.

Es gelten die Teilnahmebedingungen.\*

Vous pourriez également gagner un ensemble LEGO®.

Des conditions s'appliquent.\*

Hai anche la possibilità di vincere un set LEGO®.

Termini e condizioni sono applicabili.\*

También tienes la oportunidad de ganar un set LEGO®.

Aplican términos y condiciones.\*

您还有机会赢取乐高®套装。

条款和条件适用。\*

\*[LEGO.com/productfeedback-terms](https://LEGO.com/productfeedback-terms)





LEGO and the LEGO logo are trademarks of the/son des marques de commerce du/son marcas registradas de LEGO Group. ©2024 The LEGO Group. 6546409  
The "Lamborghini" and "Lamborghini Bull and Shield" trademarks, copyrights, designs and models are used under license from Automobili Lamborghini S.p.A, Italy.