

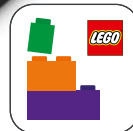

21351



Booklet available in English  
Livret disponible en français  
Folleto disponible en español



LEGO® Builder



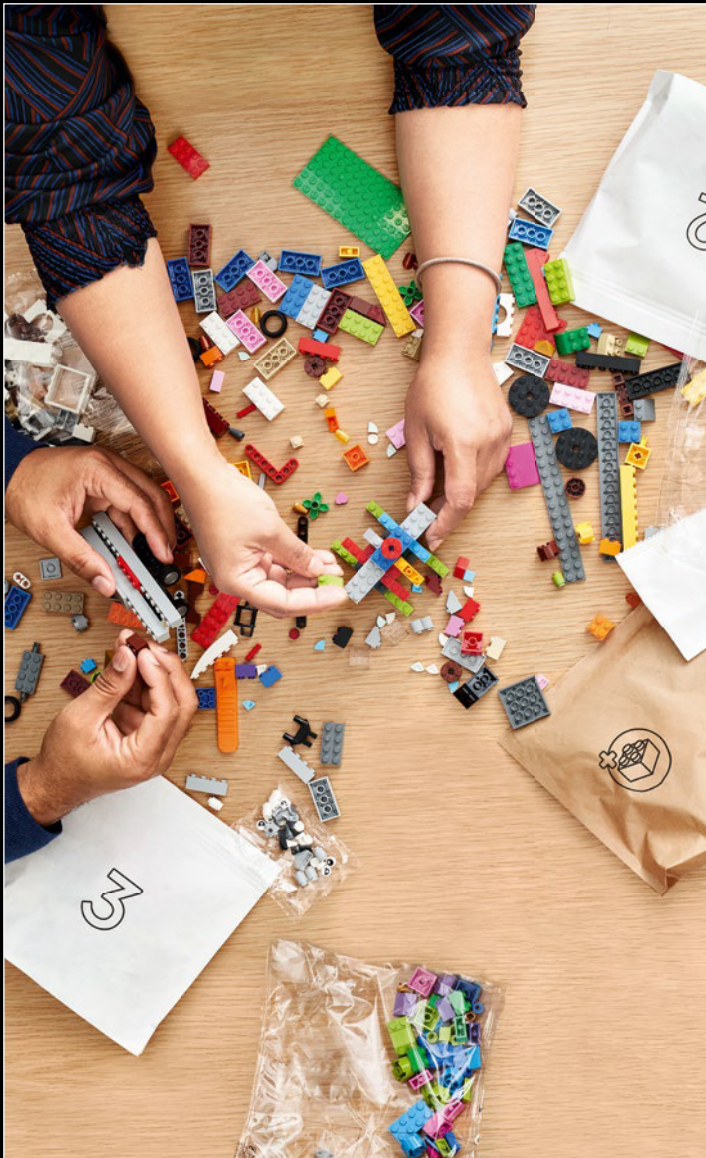

## WE'RE MAKING OUR PACKAGING MORE SUSTAINABLE

We're transitioning from single-use plastic to paper-based packaging. As we progress, you may find a mix of paper and plastic in our boxes.

## NOUS RENDONS NOS EMBALLAGES PLUS DURABLES

Nous passons des emballages en plastique à usage unique aux emballages à base de papier. Durant la transition, vous pourriez trouver un mélange de papier et de plastique dans nos boîtes.

## QUEREMOS HACER MÁS SUSTENTABLES NUESTROS MATERIALES DE EMBALAJE

Estamos cambiando las bolsas de plástico desechables por bolsas con base de papel. Conforme avanzamos en este propósito, puedes encontrar una mezcla de papel y de plástico en nuestras cajas.

[LEGO.com/sustainable-packaging](https://LEGO.com/sustainable-packaging)



# BUILDER



Apple and the Apple logo are trademarks of Apple Inc., registered in the U.S. and other countries and regions. App Store is a service mark of Apple Inc. Google Play and the Google Play logo are trademarks of Google LLC. Tencent and the Tencent logo are trademarks of Tencent Inc.

Q [LEGO.com/devicecheck](https://www.lego.com/devicecheck)



Q LEGO® Builder

# MEET THE FAN DESIGNER

Like the Pumpkin King himself, fan designer Simon Scott (LEGO® Ideas name Tvrulesmylife) loves the spirit of Halloween Town. In our world, the marketing manager from Derbyshire, UK, often frequents LEGO fan shows in his home country and is very active in the LEGO fan community.

"Like many LEGO fans, I remember building as a child, and then I rediscovered my love of LEGO bricks with the birth of my children. Over the past ten years, I have made many close friends within the AFOL community. Being a fan of *Disney Tim Burton's The Nightmare Before Christmas*, I didn't start the build for LEGO Ideas – I just wanted to make it for myself and my family as fans of the movie. My actual LEGO submission was a revision of a previous submission that reached 10,000 supporters. It wasn't selected at the time, but after a year of displaying the original project at LEGO fan shows around the country, several friends within the LEGO community persuaded me to give it another go. So, I made several design changes to improve the model. I had collected a wealth of comments and suggestions from fans of the movie and started incorporating them into the build. I like how the slanted pillars of the town hall turned out, by using hinge bricks to achieve the angles and then covering them with decorative arches. I was keen to incorporate some play features, and making tiny interiors for Jack's house was especially challenging, so I ended up building a bigger house to accommodate them. Sometimes less is more, and I did end up removing some elements before submitting the final model. I was amazed to see it reach 10,000 votes and how fast it happened – I think it's a testament to the popularity of the movie. Thank you to everyone who voted!"

*Fan designer Simon with his approved submission  
Le concepteur amateur, Simon, avec sa proposition approuvée  
Simon, el fan diseñador, con su propuesta aprobada*



# RENCONTRE AVEC LE CONCEPTEUR AMATEUR

Tout comme le Roi des citrouilles lui-même, le concepteur amateur Simon Scott (pseudonyme LEGO® Ideas : Tvrulesmylife) adore l'esprit de la ville d'Halloween. Dans notre monde, ce responsable marketing du Derbyshire, au Royaume-Uni, fréquente souvent les expositions d'amateurs de LEGO dans son pays d'origine et est très actif au sein de la communauté des amateurs de LEGO.

« Comme beaucoup d'amateurs de LEGO, je me souviens avoir construit quand j'étais petit, puis j'ai redécouvert mon amour pour les briques LEGO à la naissance de mes enfants. Au cours des dix dernières années, je me suis fait de nombreux amis proches au sein de la communauté des adultes passionnés de LEGO (AFOL). En tant qu'amateur de *L'étrange Noël de monsieur Jack* de Tim Burton et Disney, j'ai d'abord commencé à concevoir le modèle non pas pour LEGO Ideas, mais pour moi et ma famille. Ma proposition LEGO actuelle était une révision d'une proposition précédente qui avait atteint 10 000 votes. Le modèle n'a pas été sélectionné à l'époque, mais après avoir présenté le projet original pendant un an lors d'expositions d'amateurs de LEGO dans tout le pays, je me suis laissé convaincre par plusieurs amis de la communauté LEGO de tenter une nouvelle fois ma chance. J'ai donc apporté plusieurs modifications à la conception pour améliorer le modèle. J'avais recueilli une foule de commentaires et de suggestions de la part des amateurs du film et j'ai commencé à les intégrer à la construction. J'aime la façon dont les piliers inclinés de l'hôtel de ville ont été réalisés, en utilisant des briques articulées pour obtenir les angles et en les recouvrant ensuite d'arcs décoratifs. Je tenais à incorporer des éléments ludiques, et il était particulièrement difficile de créer des intérieurs minuscules pour la maison de Jack, donc j'ai fini par construire une maison plus grande. Parfois, il vaut mieux privilégier la simplicité, et j'ai fini par retirer certains éléments avant de soumettre le modèle final. J'ai été stupéfait de voir qu'il avait atteint les 10 000 votes, et à une vitesse fulgurante ! Je pense que c'est un témoignage de la popularité du film. Merci à tous ceux qui ont voté ! »

# CONOCE AL FAN DISEÑADOR

Al igual que al mismísimo Rey Calabaza, al fan diseñador Simon Scott (apodado Tvrulesmylife en LEGO® Ideas) le encanta el espíritu de Ciudad Halloween. En nuestro mundo, el director de mercadotecnia de Derbyshire (Reino Unido) suele frecuentar los eventos para fans de LEGO de su país natal y es muy activo en la comunidad de fans de LEGO.

“Como muchos fans de LEGO, recuerdo haber jugado con algunos sets cuando era niño, y luego redescubrí mi pasión por los bricks LEGO con el nacimiento de mis hijos. En los últimos diez años, he hecho muchos amigos cercanos dentro de la comunidad de AFOL. Como el gran fan que soy de *El Extraño Mundo de Jack*, el éxito cinematográfico de Disney y Tim Burton, mi primera intención no fue participar en LEGO Ideas, sino hacer un modelo que mis familiares y yo pudiéramos disfrutar, así como otros fans de la cinta. Mi propuesta real para LEGO fue la revisión de una participación anterior que alcanzó los 10.000 votos. En aquel momento no resultó seleccionada, pero luego de un año de exhibir el proyecto original en exposiciones para fans de LEGO de todo el país, varios amigos de la comunidad de LEGO me convencieron de que volviera a intentarlo. Así pues, me puse a trabajar en algunos cambios en el diseño para hacerlo mejor. Había reunido un montón de comentarios y sugerencias de otros fans de la película, y muchas de las modificaciones que hice al modelo se basaron en ellos. Me gustó cómo quedaron los pilares inclinados del ayuntamiento, que pude recrear usando bricks articulados que me permitieran controlar los ángulos y cubriendo estos después con arcos decorativos. El interior de la casa de Jack resultaba demasiado reducido como para incluir elementos que dieran lugar al juego, algo que era fundamental para mí, así que tuve que hacerla más grande. A veces, menos es más, por lo que terminé por eliminar algunas cosas antes de presentar el modelo final. Me sorprendió verlo alcanzar los 10.000 votos y lo rápido que sucedió; creo que eso pone de manifiesto la gran popularidad de la película. ¡Gracias a todos los que votaron!”

# THE MAGIC OF HALLOWEEN

'Twas a long time ago, in the holiday worlds of old... In 1993, when *Tim Burton's The Nightmare Before Christmas* was released as the world's first stop-motion feature-length movie, its lasting success seemed unlikely at first glance. Three decades on, the odd story of a spindly, sentimental Pumpkin King of Halloween Town who kidnaps 'Sandy Claws' in a sincere, albeit misguided, attempt to escape his dreary routine and spread joy instead of fear has become a beloved classic for fans of all ages.

Celebrating Halloween Town with a LEGO® Ideas set fits right into this creative world. A surreal and ghoulishly poetic universe, the movie is saturated by a sensitive, childlike curiosity about the unknown, scary and adventurous. While it's not easy for the melancholy Jack Skellington to change his pinstripes, he embraces his chance for

change as he discovers the whimsical warmth and joy of Christmas Town. Jack's newfound purpose and optimistic passion are enchanting. Even when, despite the enthusiastic help of the well-meaning but endearingly clueless inhabitants of Halloween Town, his endeavors do not result in the magical Christmas he hoped for. The drama is innocent and profound in its logic, hilarious and tender in its tone of voice. The story moves us with quirky creations, Halloween-hued scenography, melodic dialogue, a hauntingly beautiful score, and the characters' delicate movements and facial expressions. With the unwavering support and love from his friends, his faithful ghost dog Zero, and Sally, the anxious but resourceful assistant of the slightly mad Dr. Finkelstein, Jack learns there are new ways to find your place in the world with magic and love in your heart.

# LA MAGIE D'HALLOWEEN

C'était il y a longtemps, dans le monde des fêtes présentes et futures... En 1993, lorsque *L'étrange Noël de monsieur Jack* de Tim Burton sort en tant que premier long métrage en animation image par image au monde, son succès à long terme semble improbable. Trois décennies plus tard, l'histoire étrange d'un Roi des citrouilles sentimental et squelettique de la ville d'Halloween qui kidnappe « Perce Oreilles » dans une tentative sincère, bien que malavisée, d'échapper à sa routine morne et de répandre la joie au lieu de la peur, est devenue un classique bien-aimé des amateurs de tous âges.

Célébrer la ville d'Halloween avec un ensemble LEGO® Ideas s'inscrit parfaitement dans ce monde créatif. Univers surréaliste et macabrement poétique, le film est imprégné d'une curiosité sensible et enfantine pour l'inconnu, l'effrayant et l'aventure. S'il n'est pas facile pour le mélancolique Jack Skellington de renoncer

à ses rayures, il saisit sa chance de changement en découvrant la chaleur et la joie fantasques de la ville de Noël. Le nouveau but et la passion optimiste de Jack sont enchanteurs. Même si, malgré l'aide enthousiaste des habitants de la ville d'Halloween bien intentionnés, mais adorablement désespérés, ses efforts ne lui permettent pas de réaliser le Noël magique qu'il espérait. Le récit est innocent et profond dans sa logique, hilarant et tendre dans son ton. L'histoire nous émeut grâce à des créations excentriques, une scénographie aux couleurs d'Halloween, des dialogues mélodieux, une trame sonore envoûtante et des personnages aux mouvements et expressions faciales tout en finesse. Avec le soutien et l'amour indéfectibles de ses amis, de son fidèle chien fantôme Zéro et de Sally, l'assistante anxieuse, mais ingénieuse du loufoque Dr Finkelstein, Jack apprend qu'il y a bien d'autres façons de trouver sa place dans le monde en portant magie et amour dans son cœur.



# LA MAGIA DE HALLOWEEN

"Fue hace mucho tiempo, en los mundos de las fiestas sin fin...". En 1993 se estrenó *El Extraño Mundo de Jack*, de Tim Burton, el primer largometraje de animación por pasos del mundo. A primera vista, no parecía probable que fuera a convertirse en un éxito tan perdurable. Tres décadas después, la peculiar historia del Rey Calabaza, el enjuto y sentimental monarca de Ciudad Halloween que rapta a "Santa Atroz" en un sincero, aunque equivocado, intento de escapar de su monótona rutina y difundir alegría en un lugar donde reina el miedo, se ha convertido en un clásico muy querido por fans de todas las edades.

La idea de celebrar Ciudad Halloween con un set LEGO® Ideas vibra en sintonía con este creativo mundo. La película, un universo surrealista y macabramente poético, está saturada de una curiosidad sensible e infantil por lo desconocido, lo terrorífico y lo intrépido. Aunque al melancólico Jack Skeleton

no le es fácil cambiar su atuendo a rayas, acepta la oportunidad de probar algo nuevo cuando descubre la calidez y la alegría fantástica de la aldea navideña. El nuevo propósito, así como el optimismo y pasión de Jack, resultan verdaderamente hechizantes. Incluso cuando, a pesar de la decidida ayuda de los bienintencionados pero entrañablemente despistados habitantes de Ciudad Halloween, sus esfuerzos no dan como resultado la mágica Navidad que esperaba. El drama es inocente y profundo en su lógica, y tierno e hilarante en su tono de voz. La historia nos conmueve con extravagantes creaciones, una escenografía con tonos de Halloween, diálogos melódicos, una partitura inquietantemente hermosa y los delicados movimientos y expresiones faciales de los personajes. Con el apoyo y el amor inquebrantables de sus amigos, de su fiel perro fantasma Zero y de Sally, la ansiosa pero ingeniosa ayudanta del un poco desquiciado Dr. Finkelstein, Jack aprende que hay nuevas formas de encontrar tu lugar en el mundo con magia y amor en el corazón.

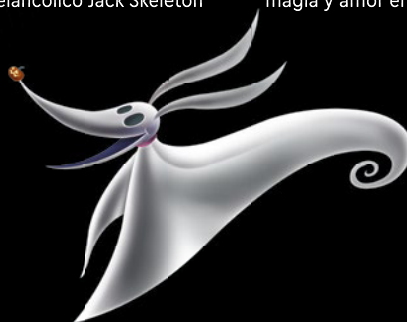

# FROM THE LEGO® IDEAS DESIGNER TEAM

"Simon simply did an amazing job recreating all the mystifying, asymmetrical and crooked angles of Halloween Town. We implemented several interesting building techniques to ensure an engaging display and fun play options, and to give fans a great building experience. Every space has been faithfully replicated in minute detail, with lots of references to the movie – and to Simon. You may recognize some of the tombstone inscriptions and find some

of Jack's most precious possessions in his house. With the LEGO® minifigure characters and the three main sections of the model, you can recreate some of the most iconic and fan-favorite scenes. You can also separate the main sections for a different display arrangement. We hope you will have fun discovering every little detail as you build."  
- From the LEGO® Ideas Designer Team



*Beware, remnants of Sally's Fog Juice fumes may still be exuding from the fountain...*

*Attention, il se peut que les vapeurs du jus de brouillard de Sally s'échappent encore de la fontaine...*

*¡Cuidado! Es posible que la fuente siga exudando restos del jugo de niebla de Sally...*



*"This year, Christmas will be ours!" Jack may have found the perfect formula for that special Christmas feeling!*

*« Cette année, c'est nous qui allons célébrer Noël ! » Jack a peut-être trouvé la formule parfaite pour le prodigieux sortilège de Noël !*

*"¡Este año, Navidad será nuestra!". Es posible que Jack encontrara la fórmula perfecta para sentir esa Navidad tan especial.*





## UN MOT DE L'ÉQUIPE DE CONCEPTION LEGO® IDEAS

« Simon a fait un travail extraordinaire en recréant tous les angles mystérieux, asymétriques et tortueux de la ville d'Halloween. Nous avons mis en œuvre plusieurs techniques de construction intéressantes pour garantir une présentation attrayante et des options de jeu amusantes, et pour offrir aux amateurs une expérience de construction exceptionnelle. Chaque espace a été fidèlement reproduit dans les moindres détails, avec de nombreuses références au film – et à Simon. Vous reconnaîtrez peut-être certaines des inscriptions sur

les pierres tombales et trouverez certains des biens parmi les plus précieux de Jack dans sa maison. Avec les figurines LEGO® et les trois sections principales du modèle, vous pouvez recréer certaines des scènes les plus emblématiques et les plus appréciées des amateurs. Vous pouvez également séparer les sections principales pour les exposer différemment. Nous espérons que vous vous amuserez à découvrir chaque petit détail au fur et à mesure de la construction. »  
- *Un mot de l'équipe de conception LEGO® Ideas*

## IMPRESIONES DEL EQUIPO DE DISEÑADORES DE LEGO® IDEAS

"Simon hizo un trabajo sencillamente increíble recreando todos los ángulos desconcertantes, asimétricos y retorcidos de Ciudad Halloween. Pusimos en práctica una variedad de técnicas de construcción interesantes para asegurar un modelo de exhibición vistoso y divertidas opciones para jugar, y también para ofrecer a los fans una extraordinaria experiencia de construcción. Cada espacio se reprodujo con la mayor fidelidad y minuciosidad. Hay incontables referencias a la película... y a Simon. Es posible que reconozcas

algunas de las inscripciones de las lápidas y que encuentres las pertenencias más preciadas de Jack en su casa. Con los personajes en formato de minifigura LEGO® y las tres secciones principales del modelo, podrás recrear algunas de las escenas más emblemáticas y preferidas por los fans. También puedes separar las secciones principales para exhibirlas de diferentes maneras. Esperamos que te diviertas descubriendo cada pequeño detalle mientras construyes".  
- *Impresiones del equipo de diseñadores de LEGO® Ideas*



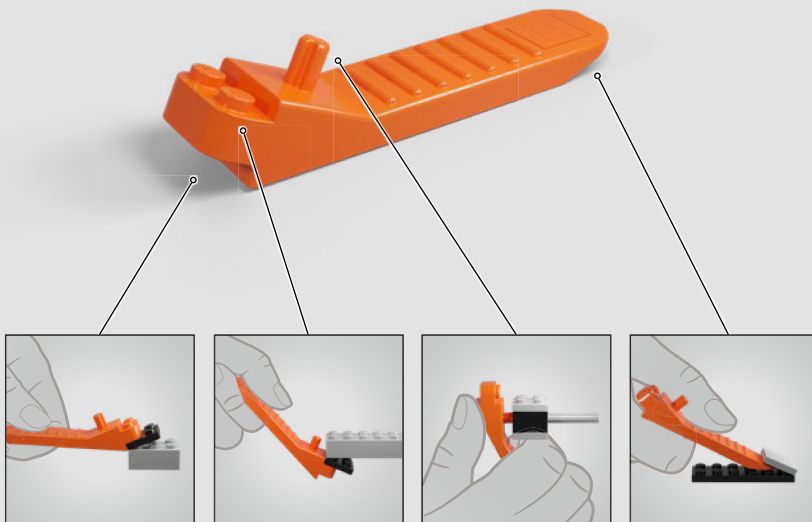

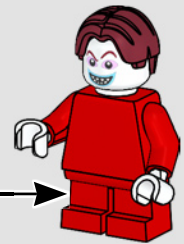
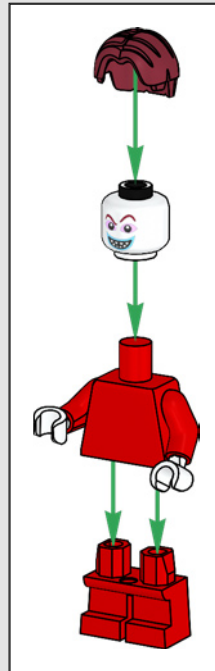

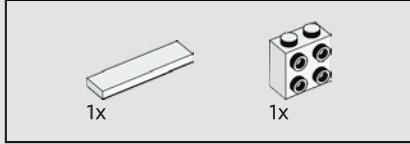
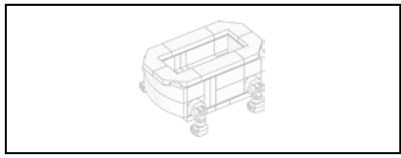

1

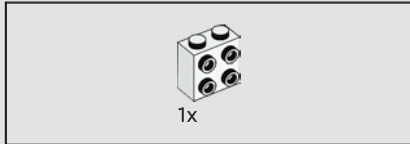
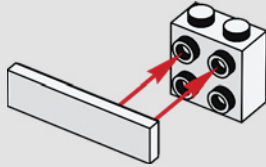

2

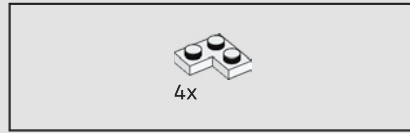
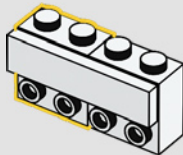

3

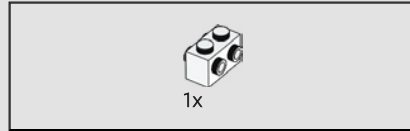
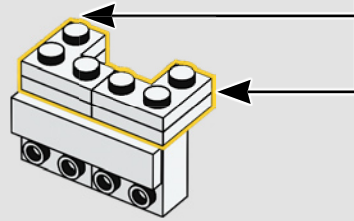
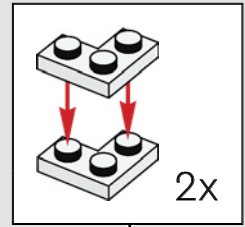

4

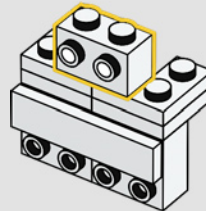



5

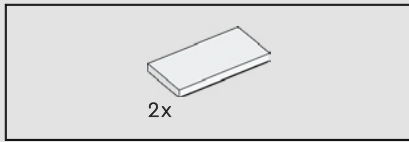
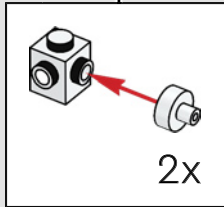
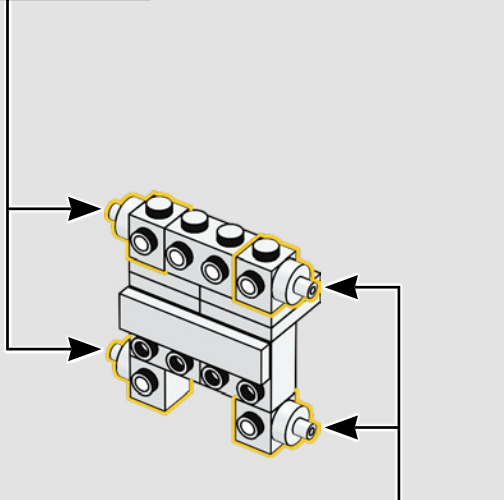
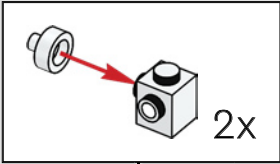

6

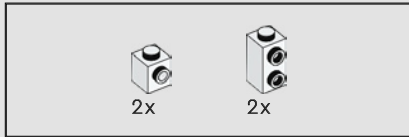
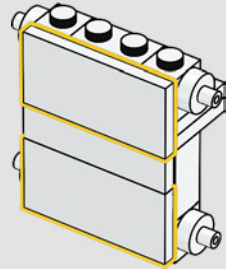

7

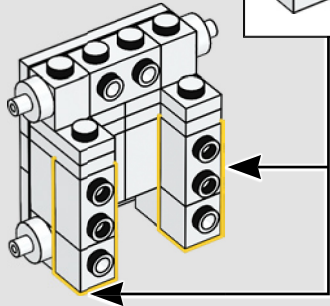
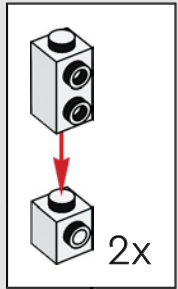

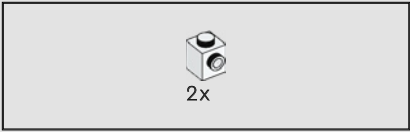

8

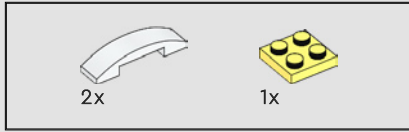
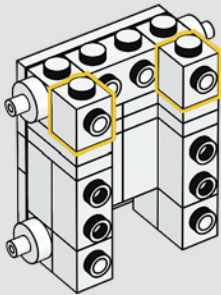

9

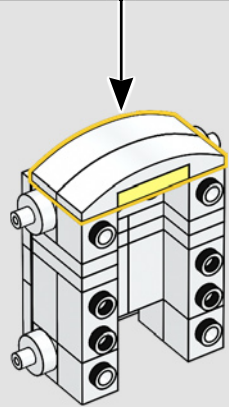
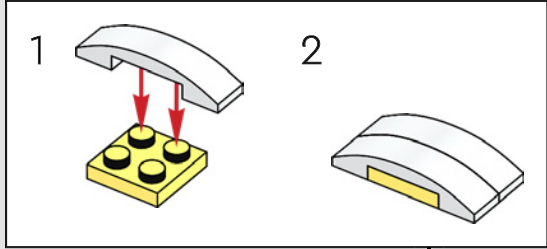

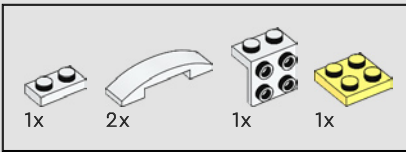

10

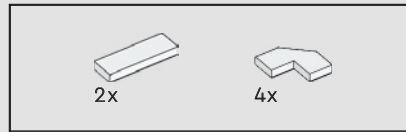
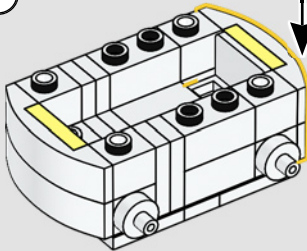
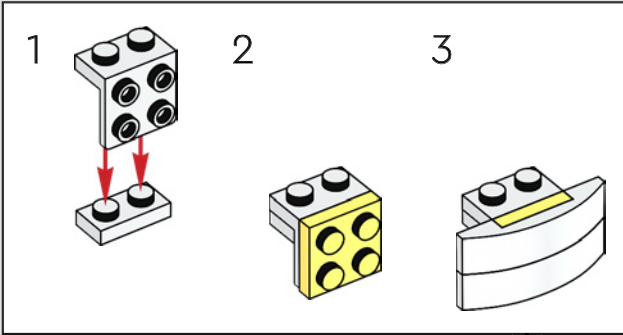

11

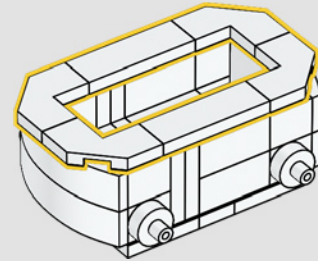

12

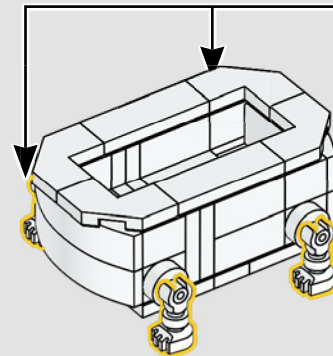

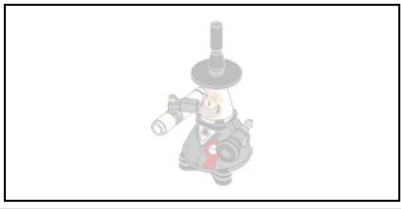

1

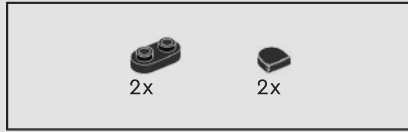
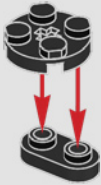

2

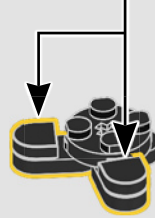
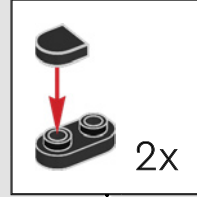

3







4

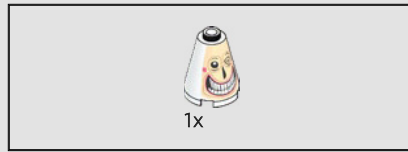
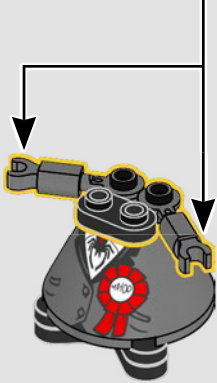
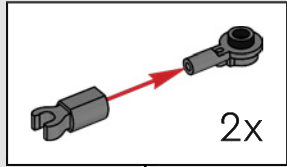

5

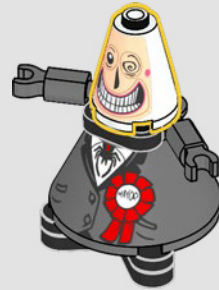



6

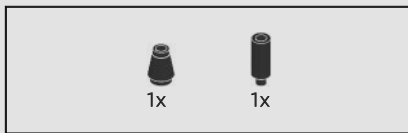
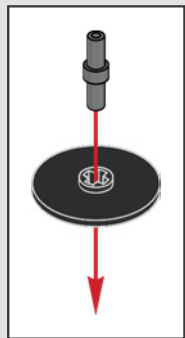

7

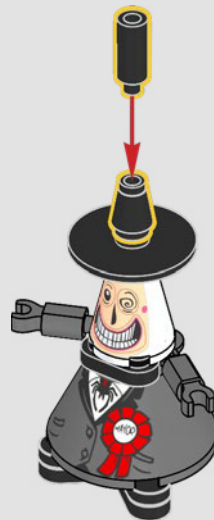

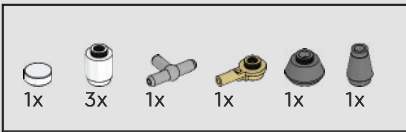

8

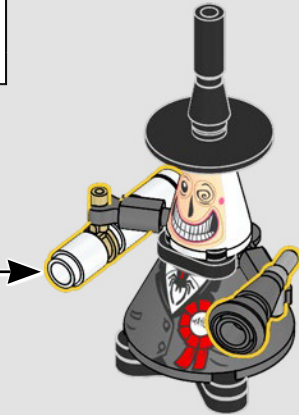
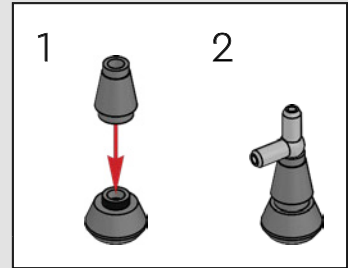
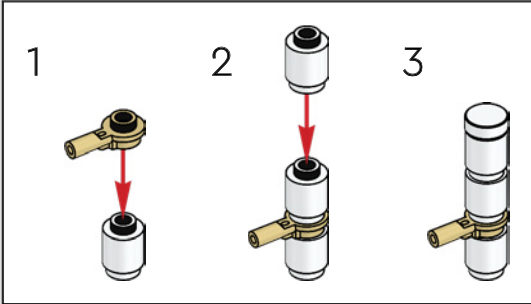

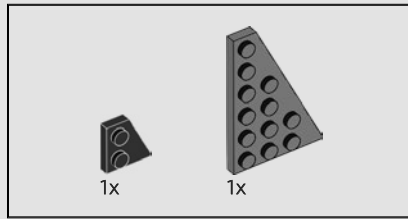

1

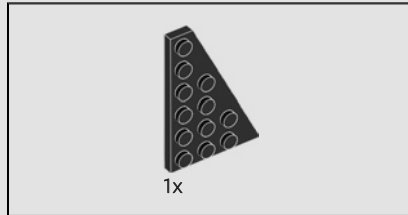
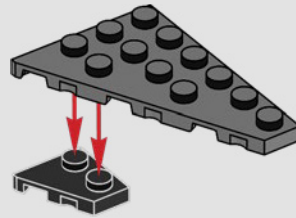

2

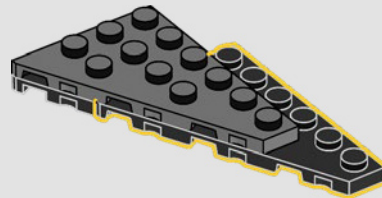

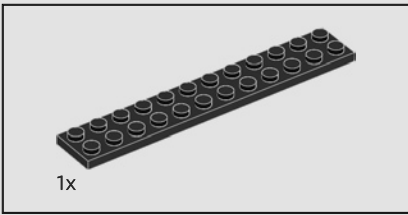

3

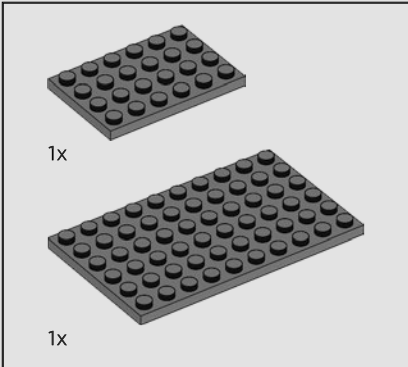
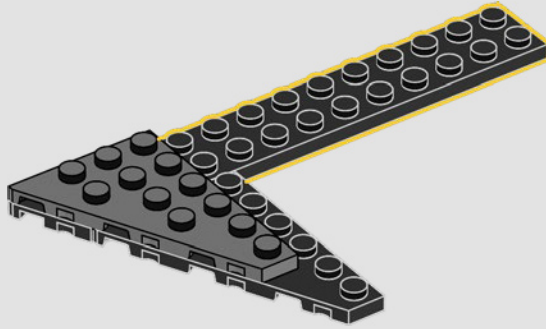

4

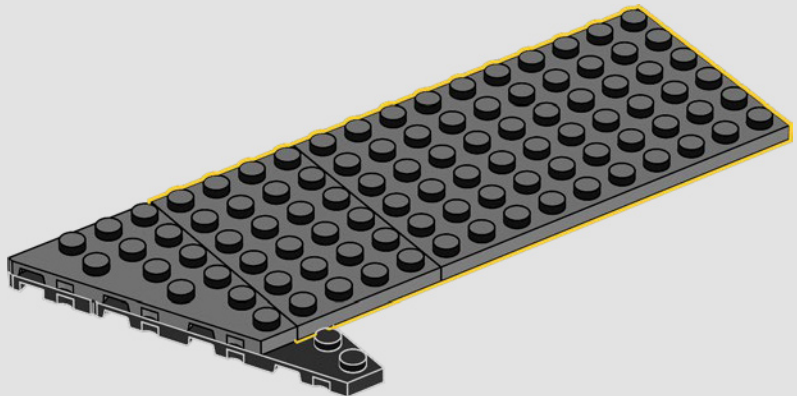

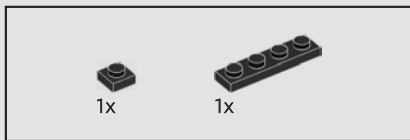

5

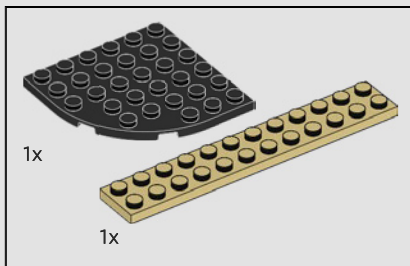
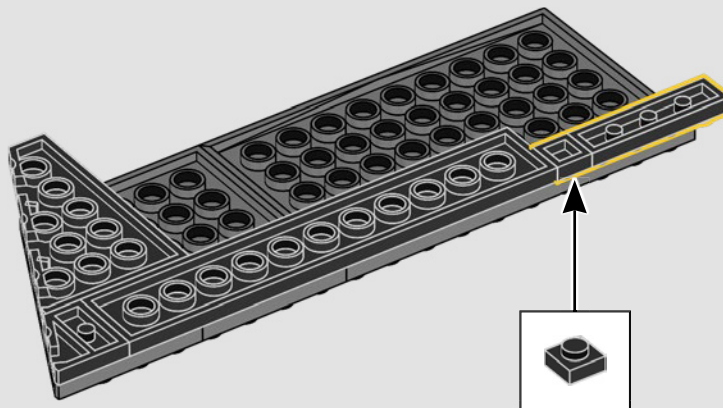

6

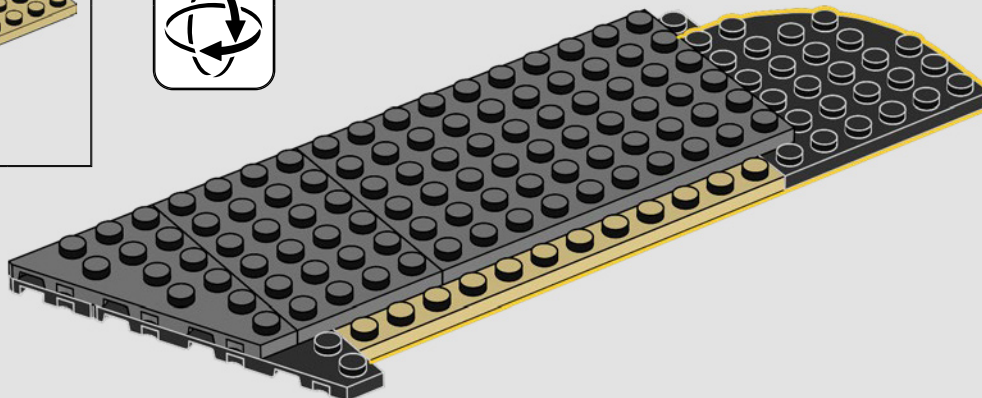

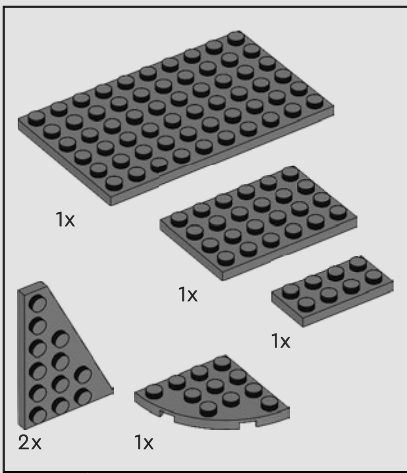

7

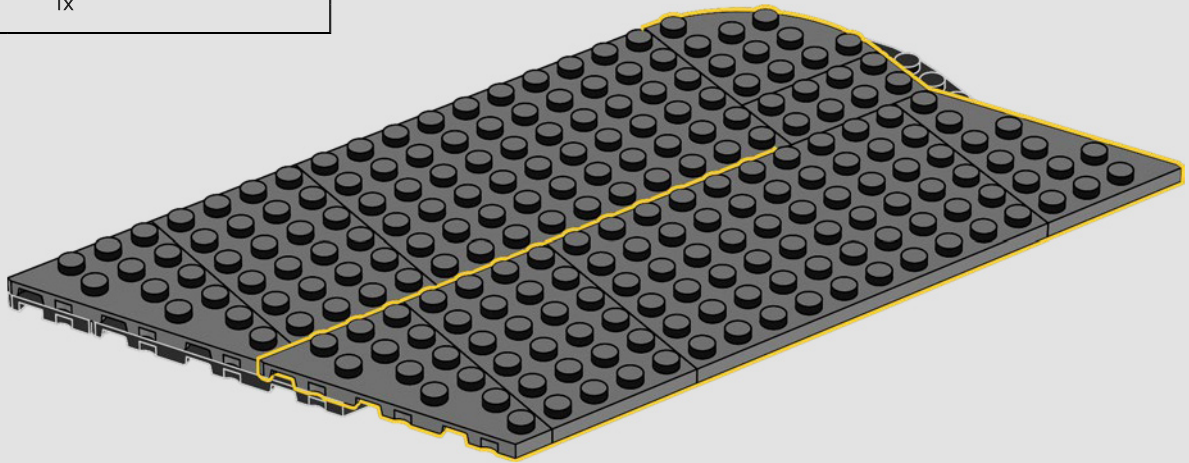

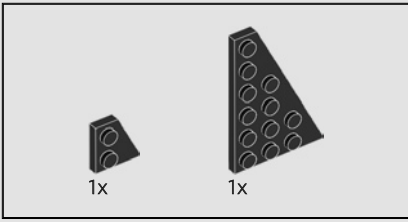

8

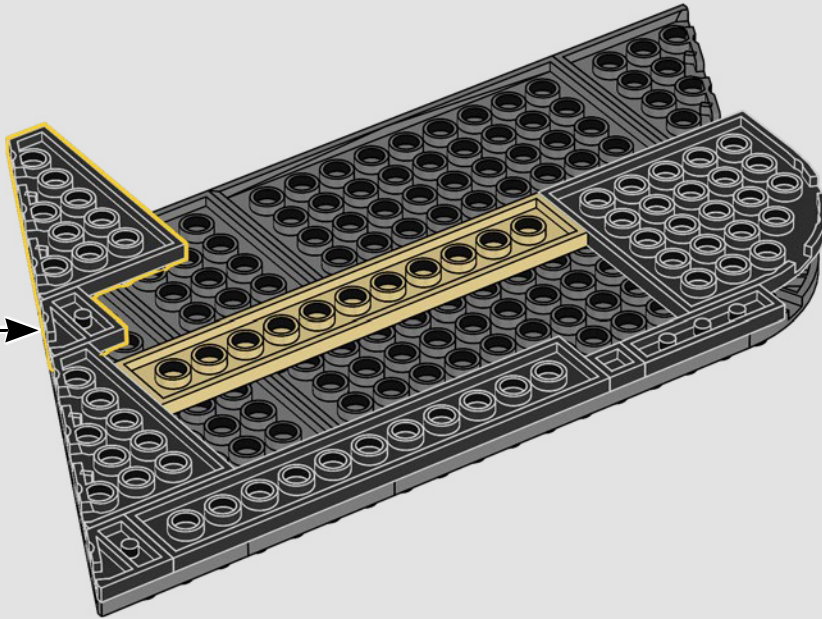
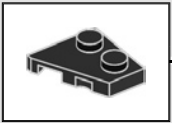



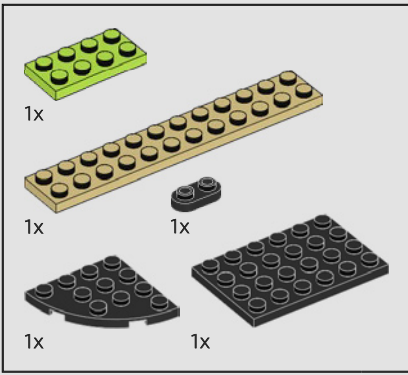

9

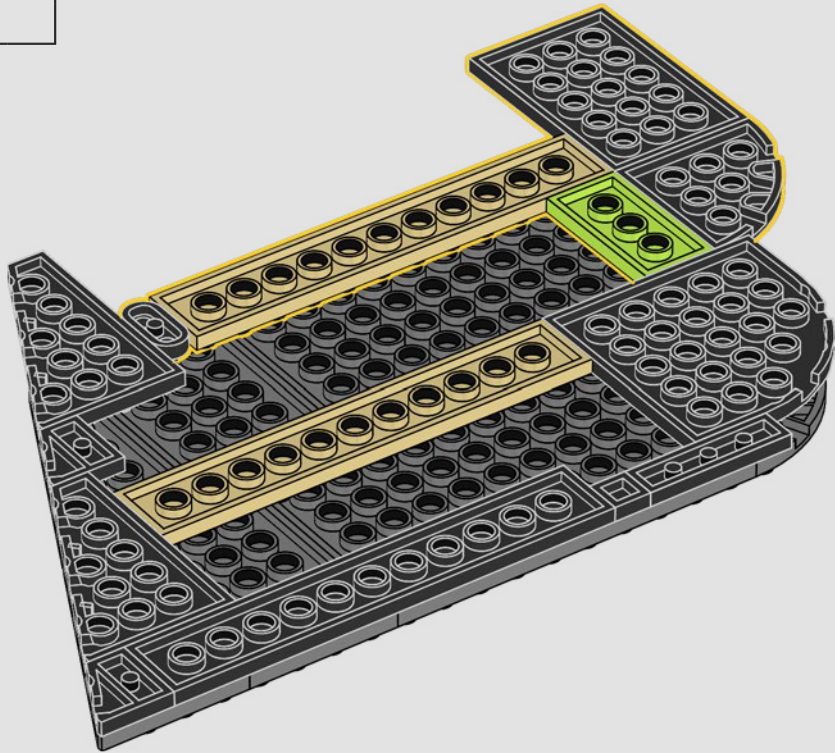

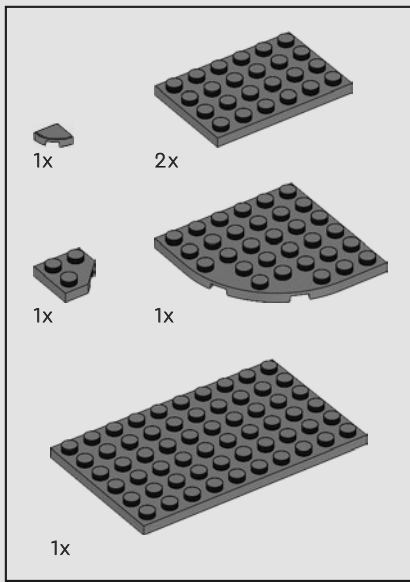

10

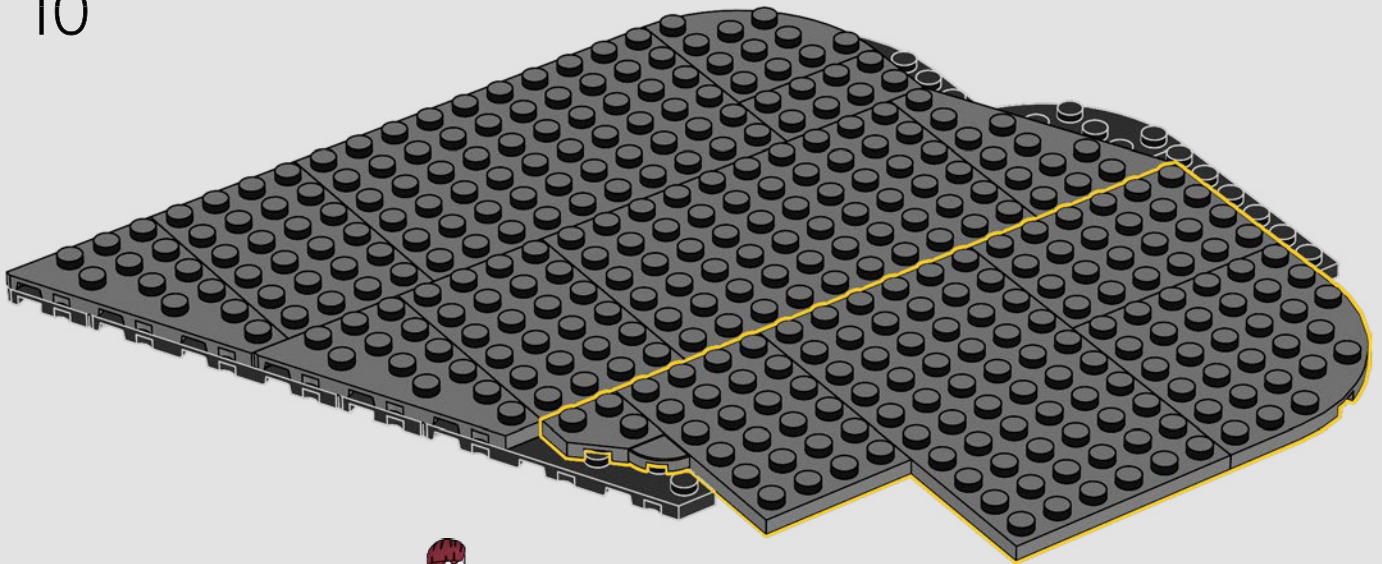

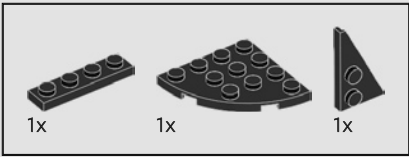

11

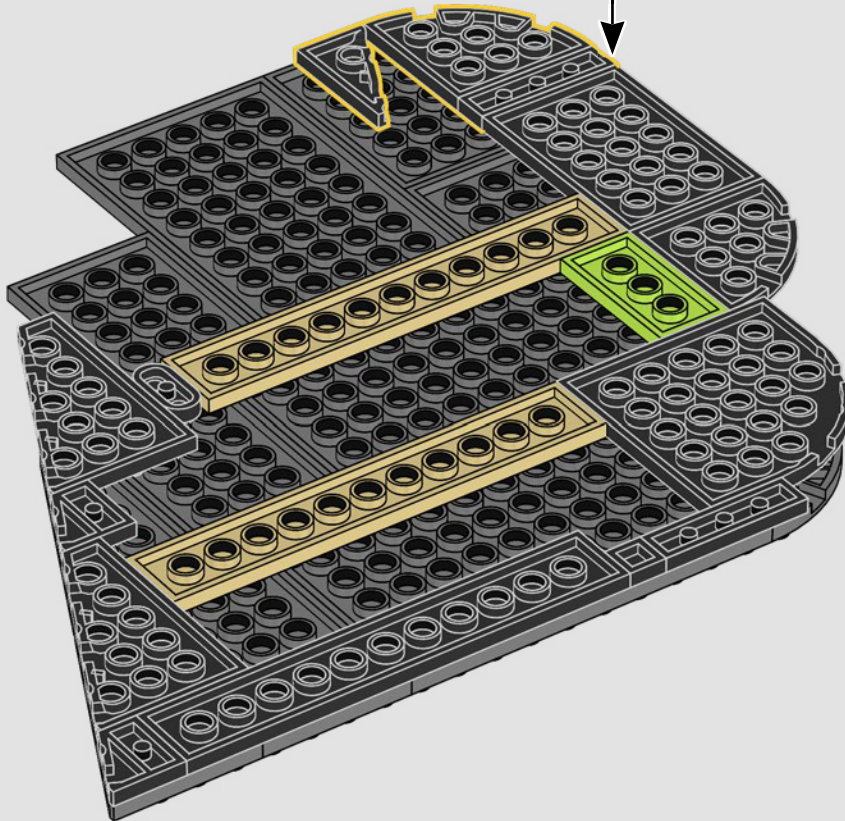
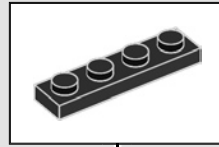

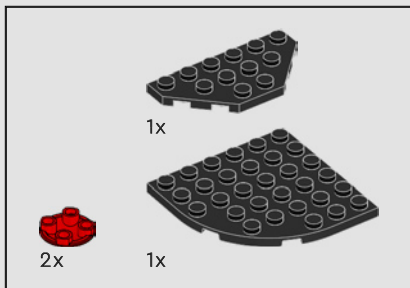

12

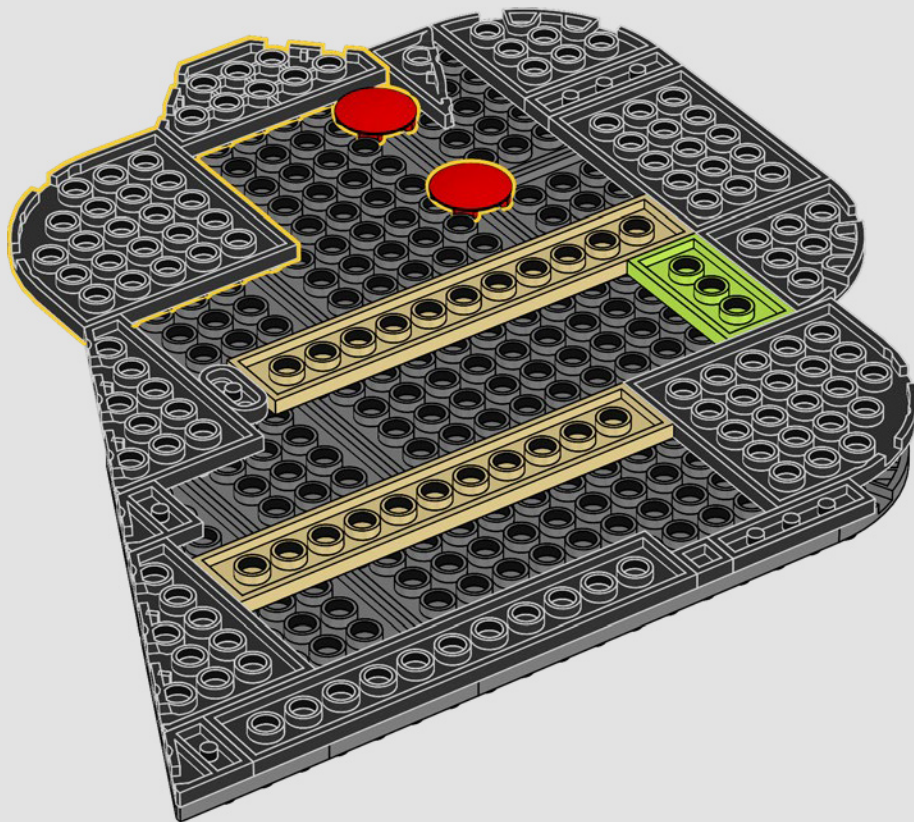

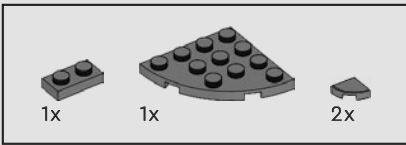

13

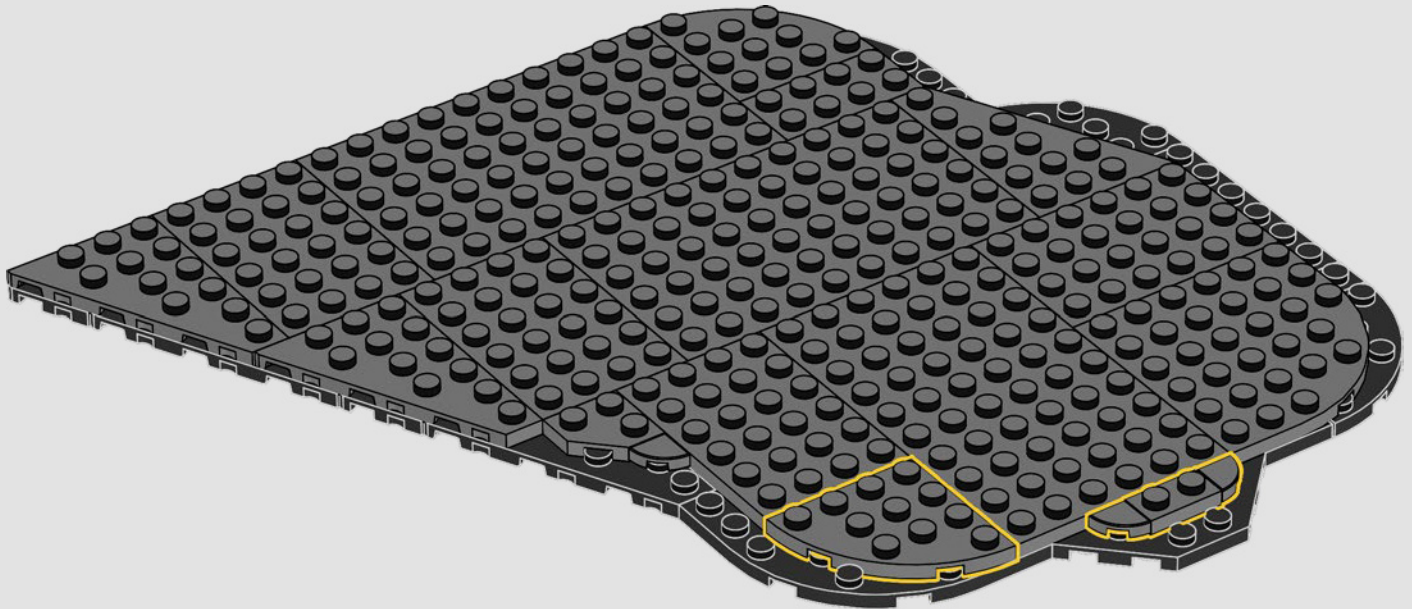

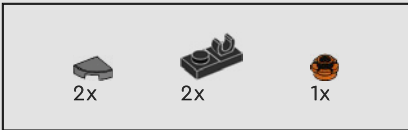

14



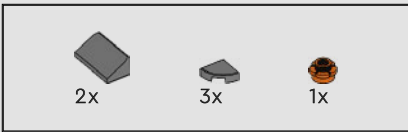

15

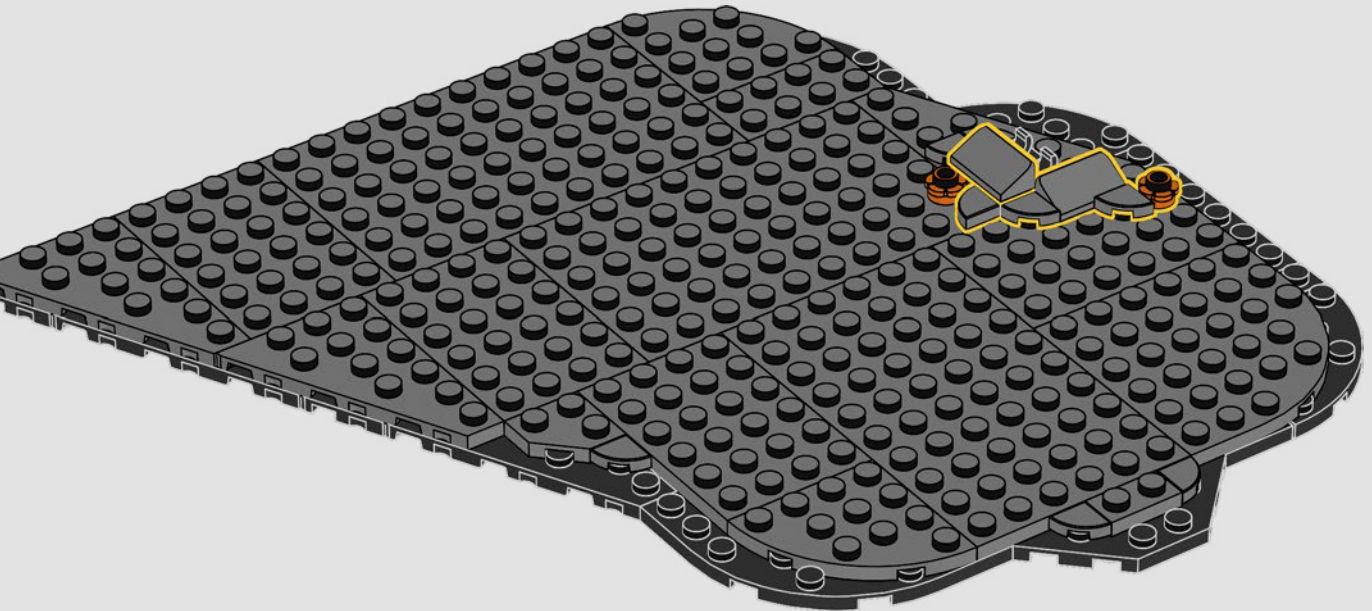



16





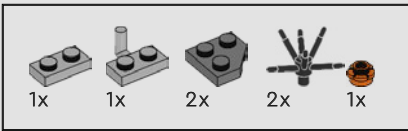

17

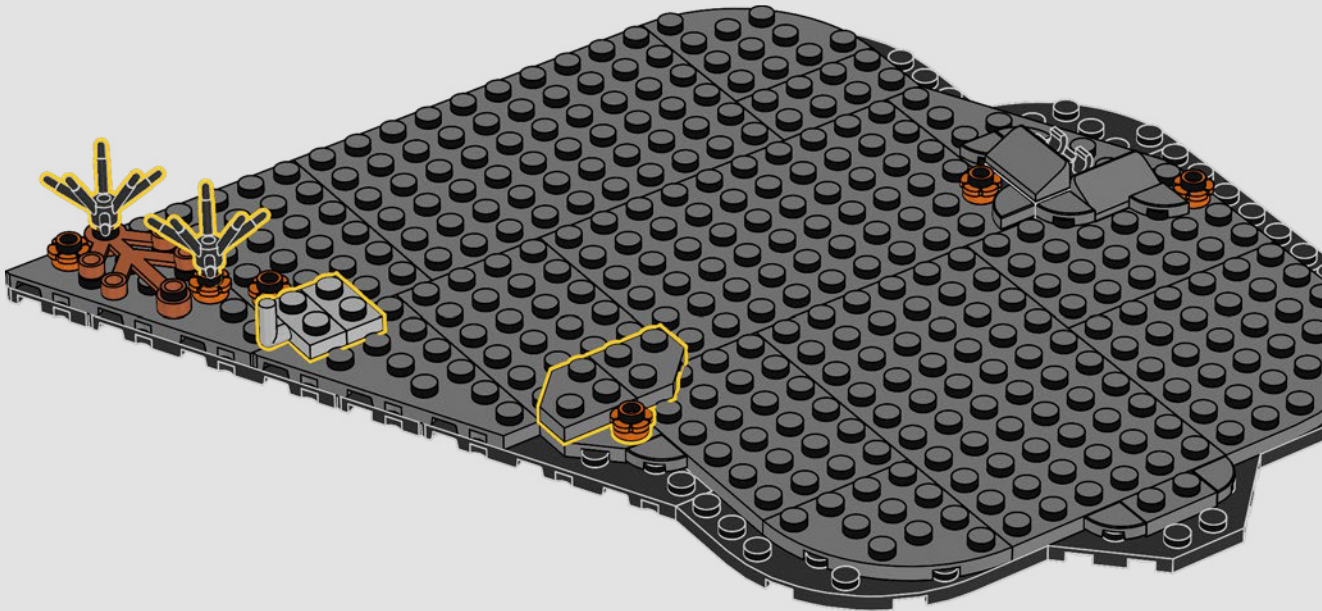

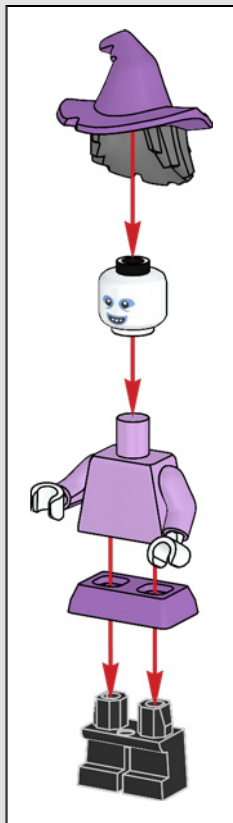

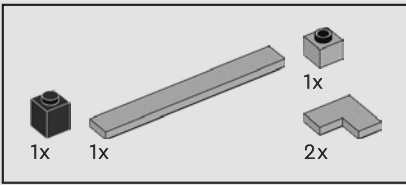

18

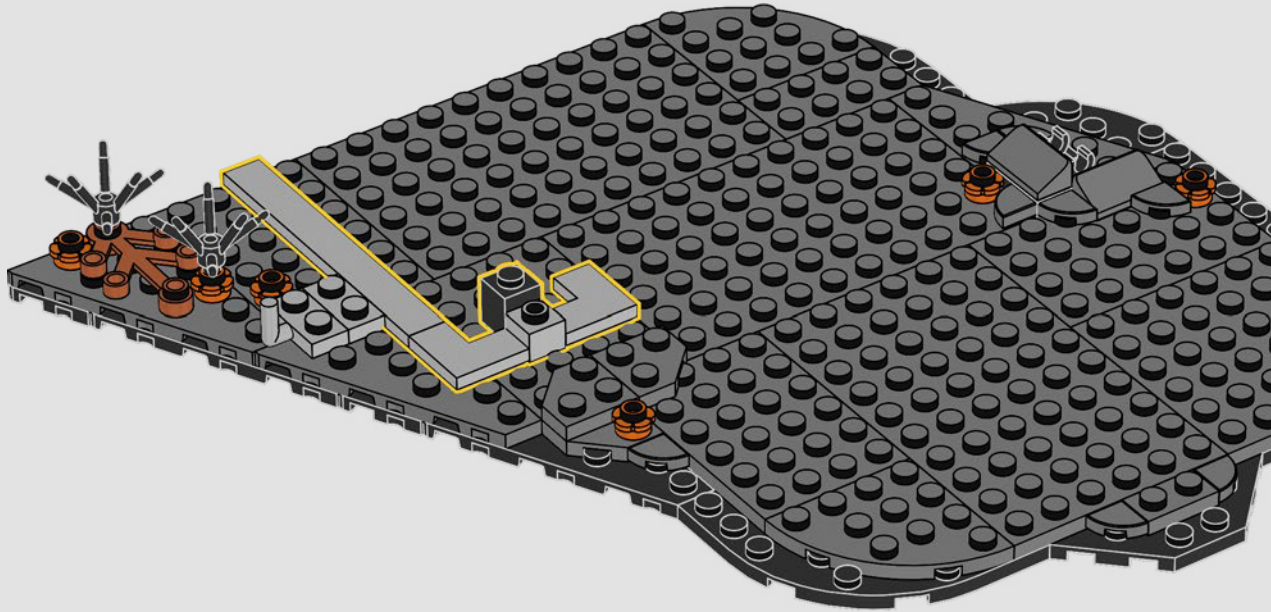

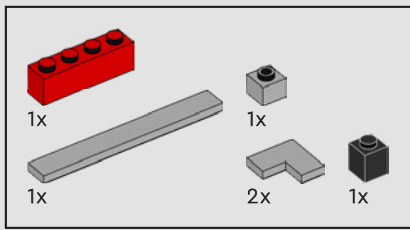

19

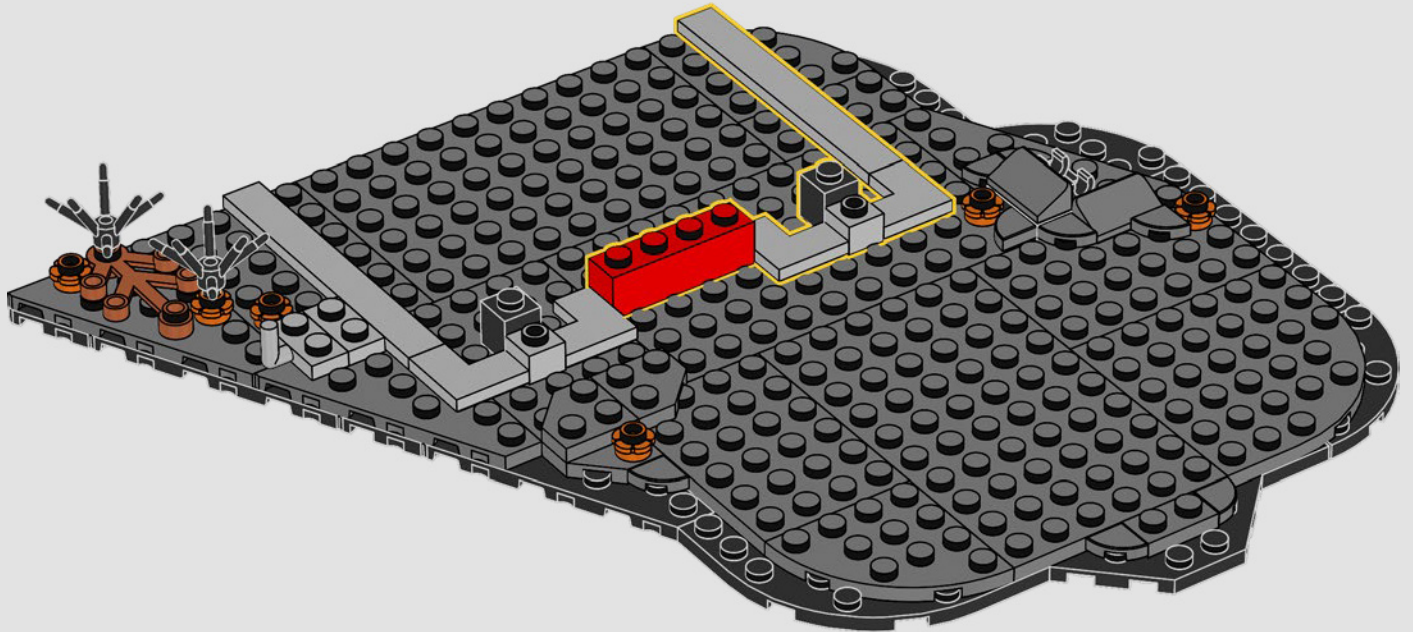

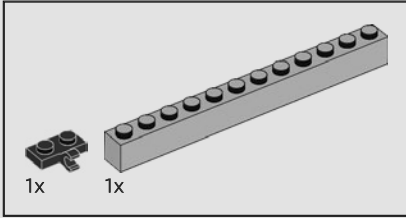
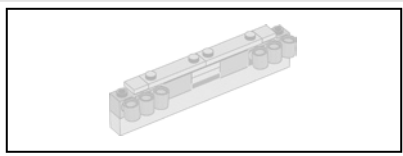

20

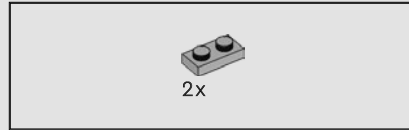
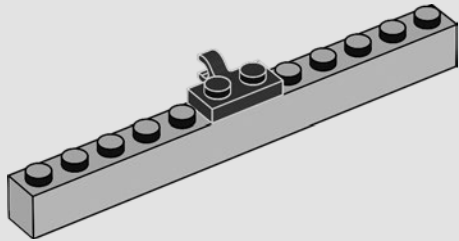

21

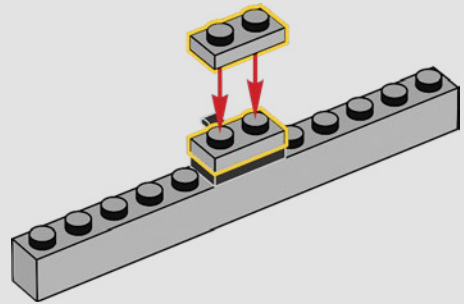

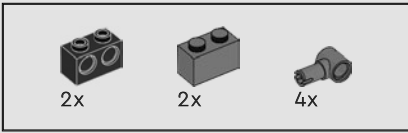

22

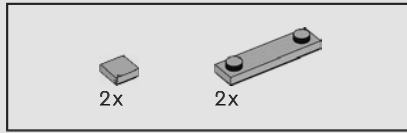
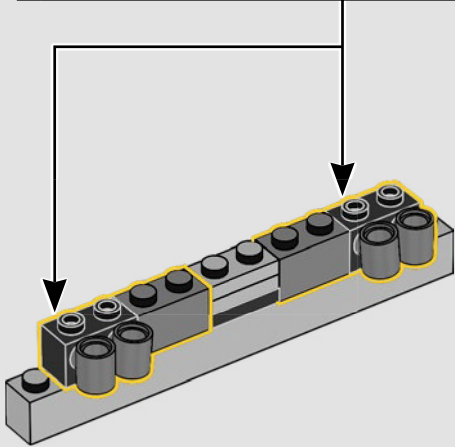
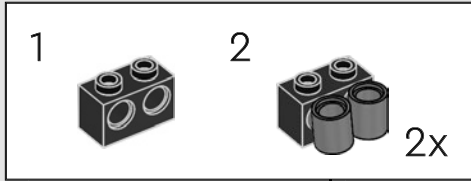

23

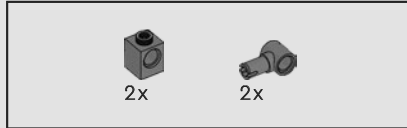
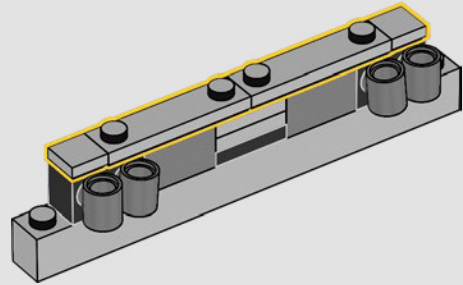

24

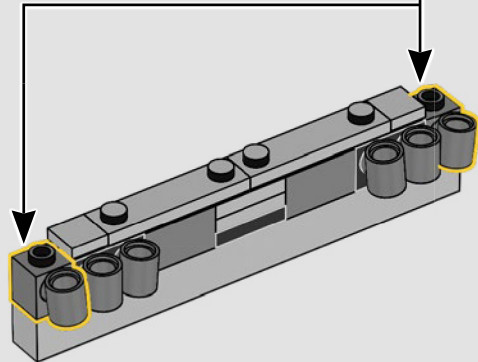
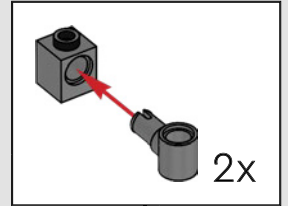

25

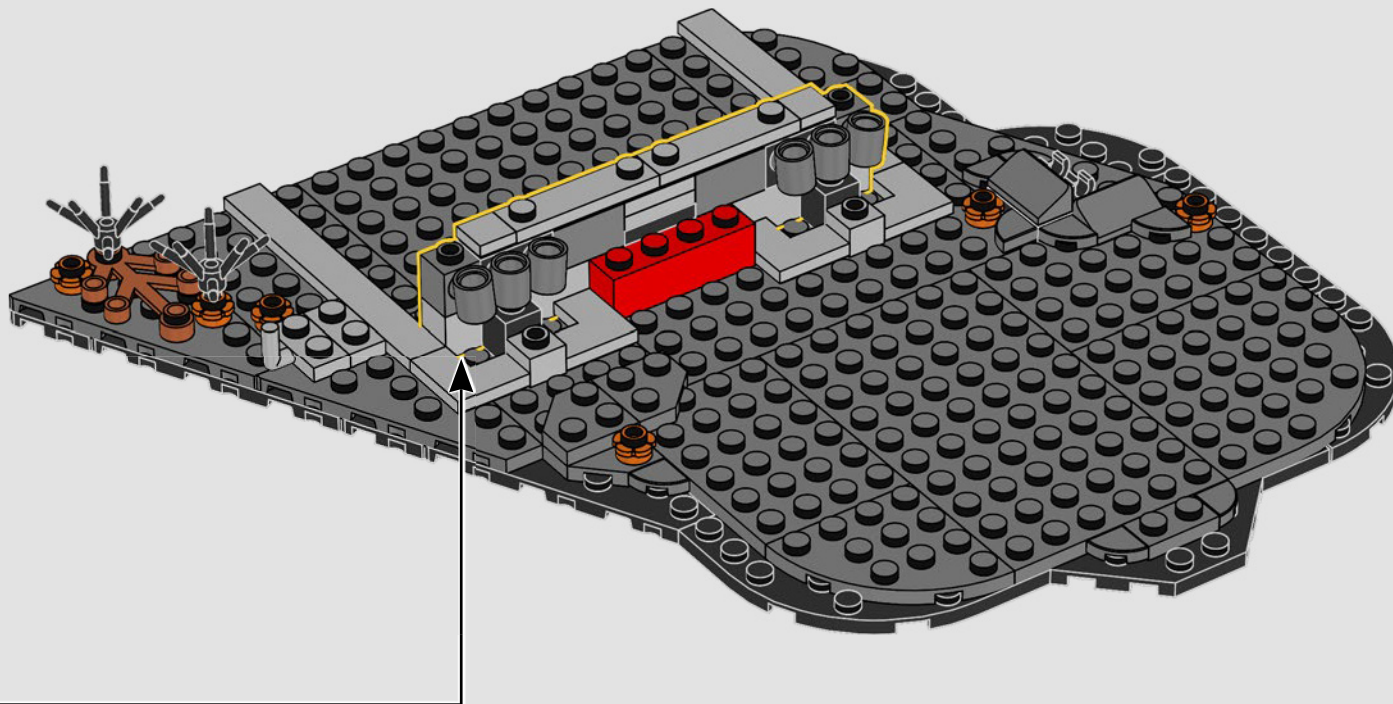

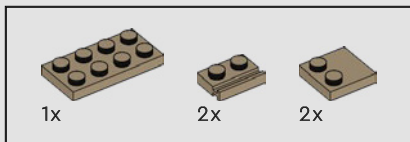

26

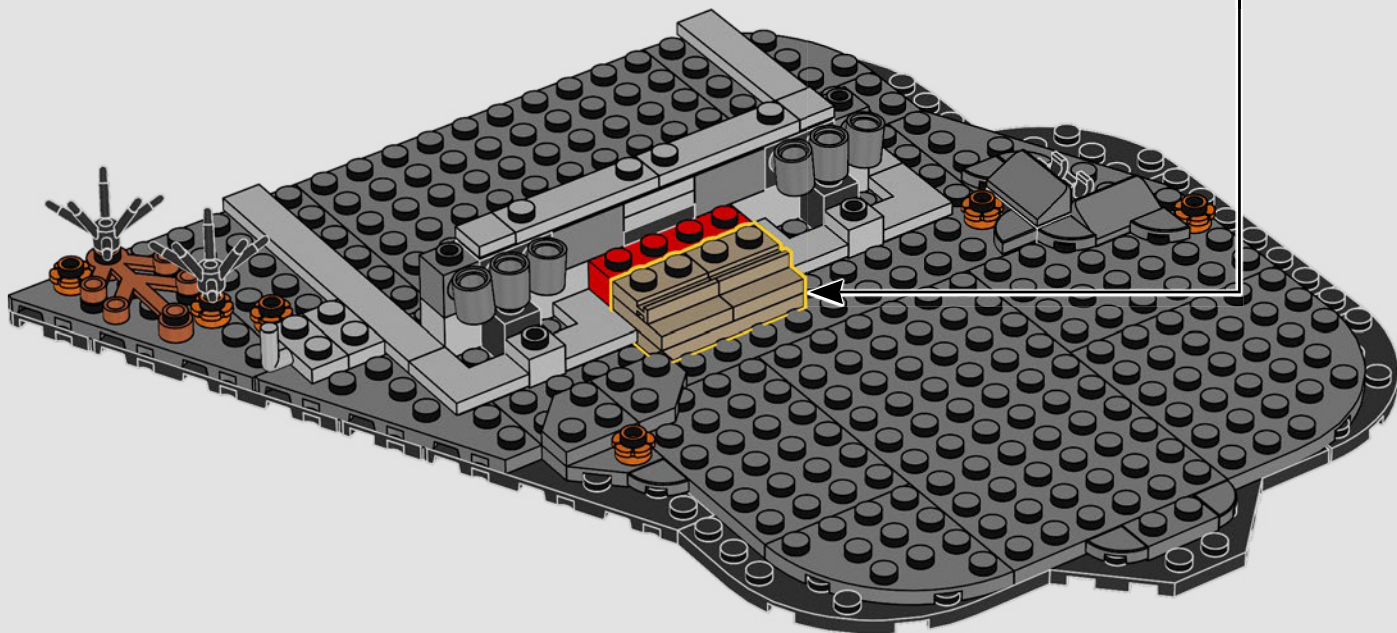
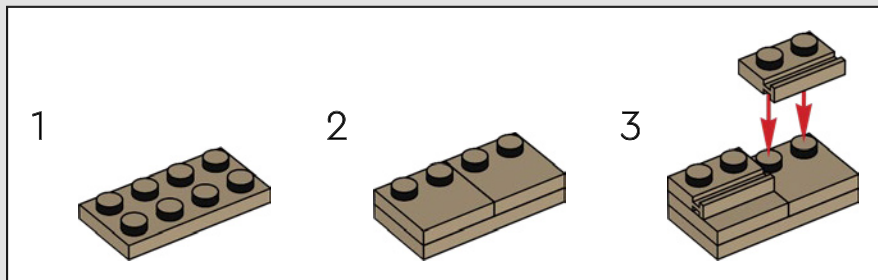



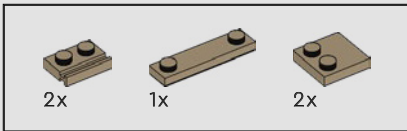

27

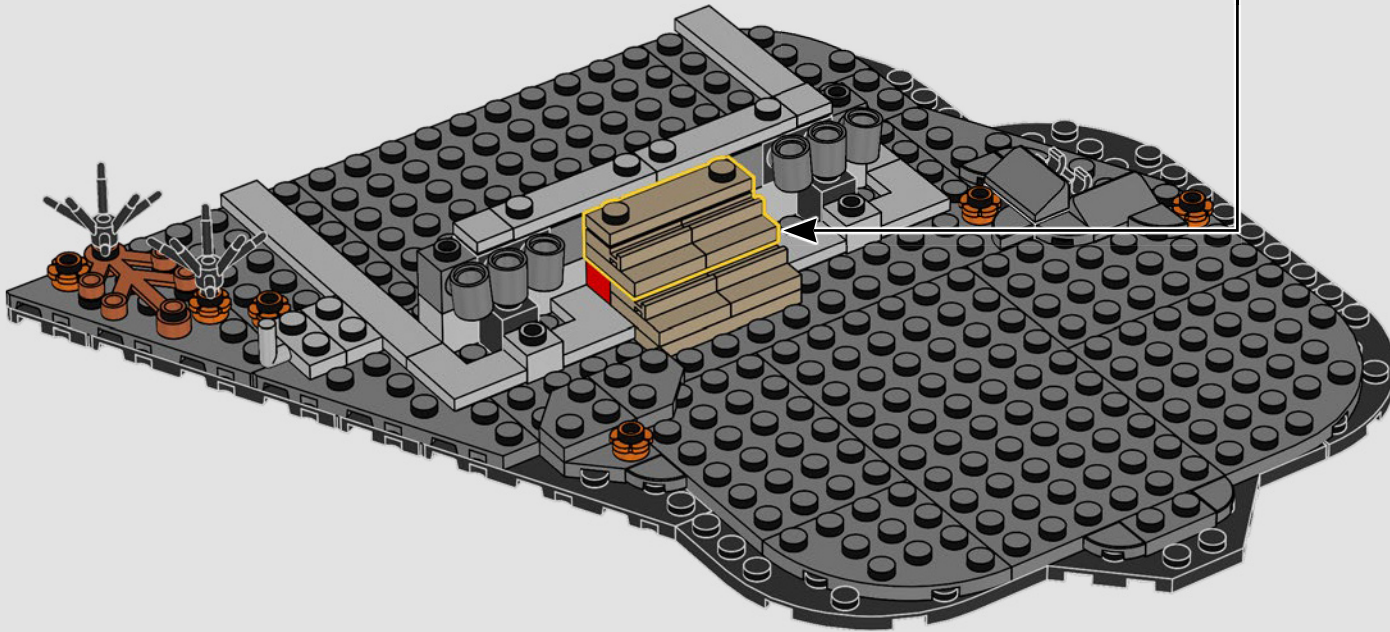
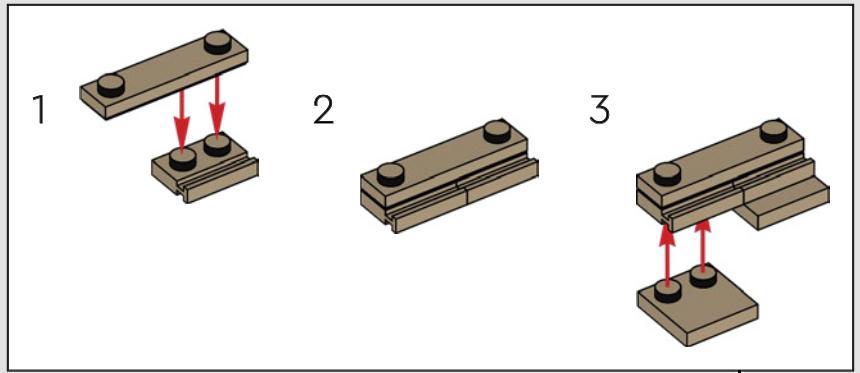



28

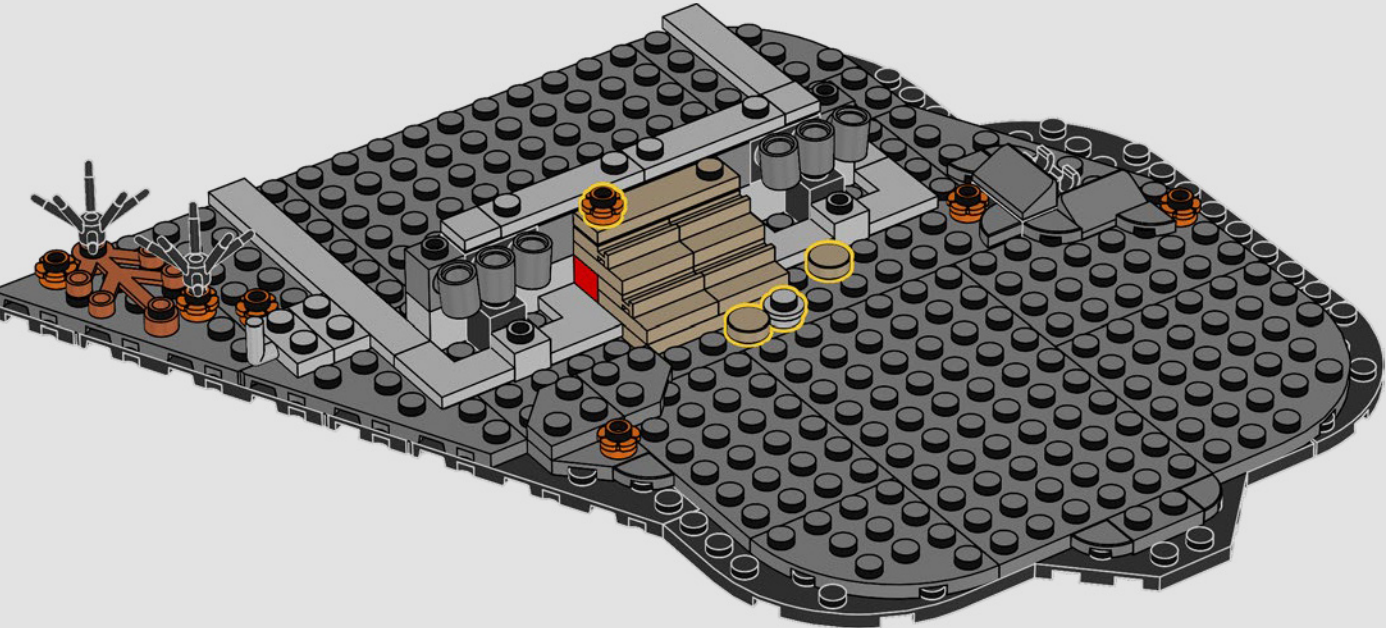



29

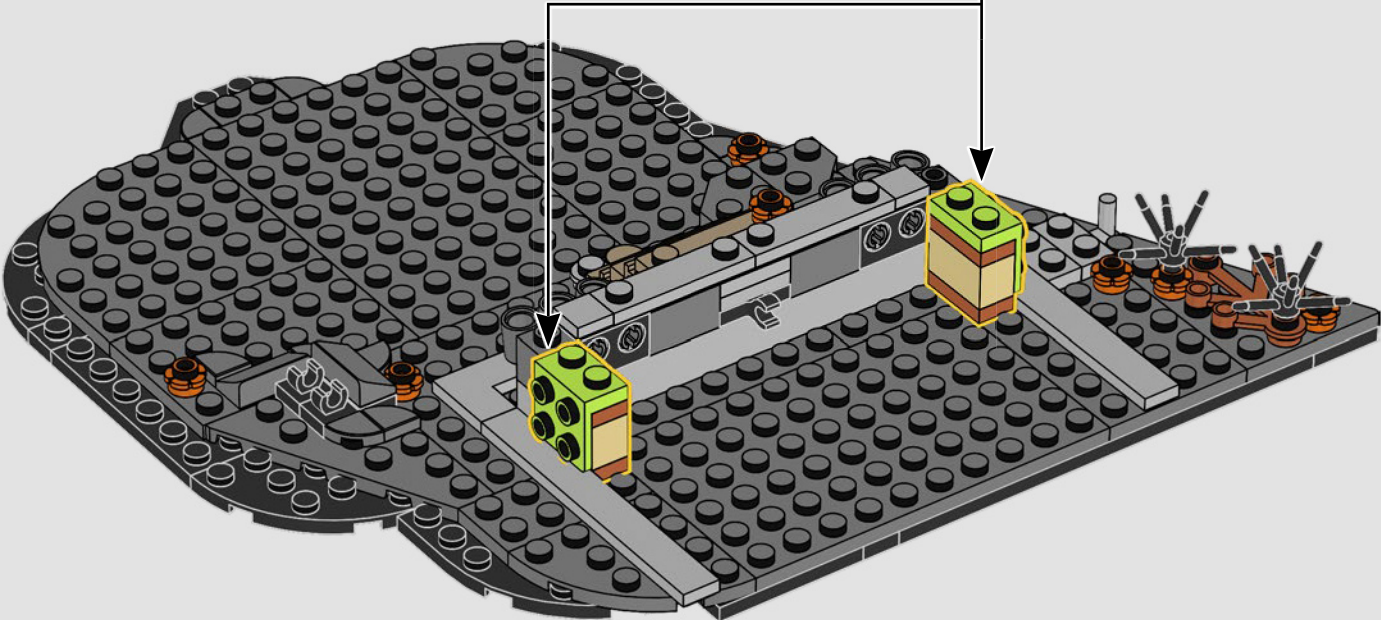
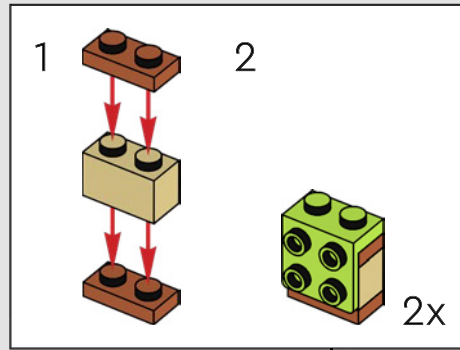

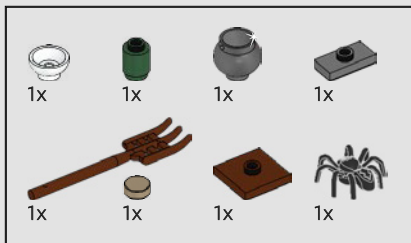

30

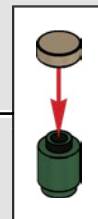
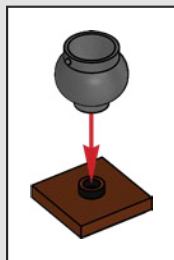

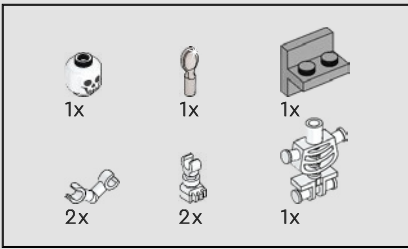

31

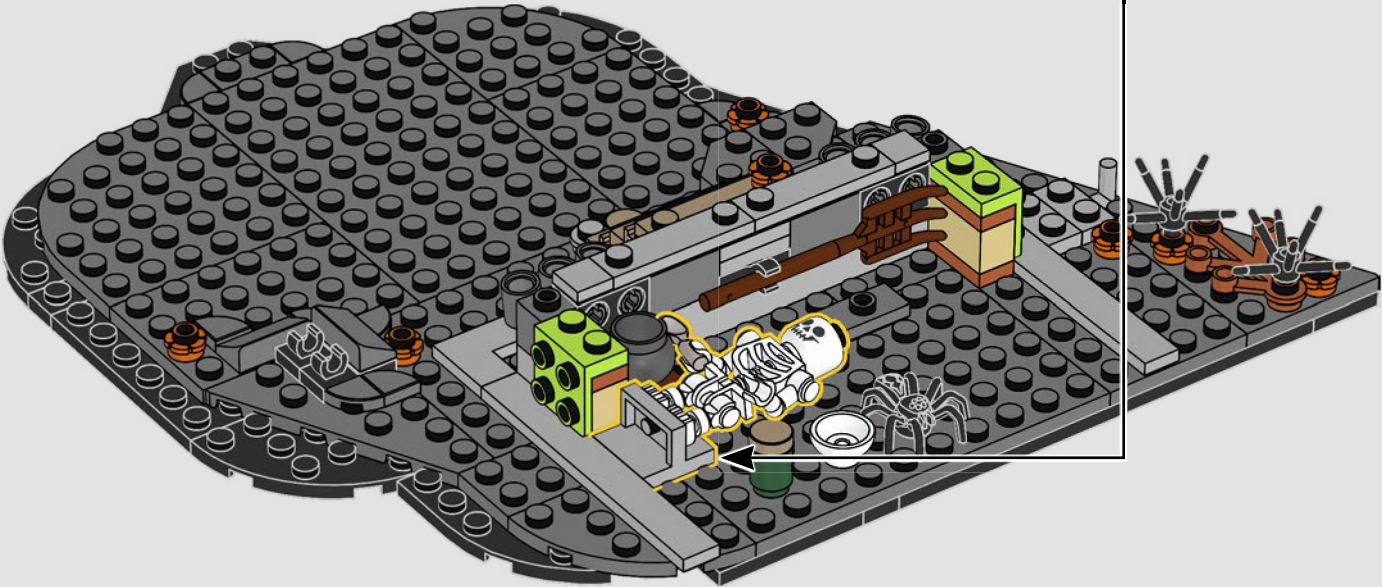
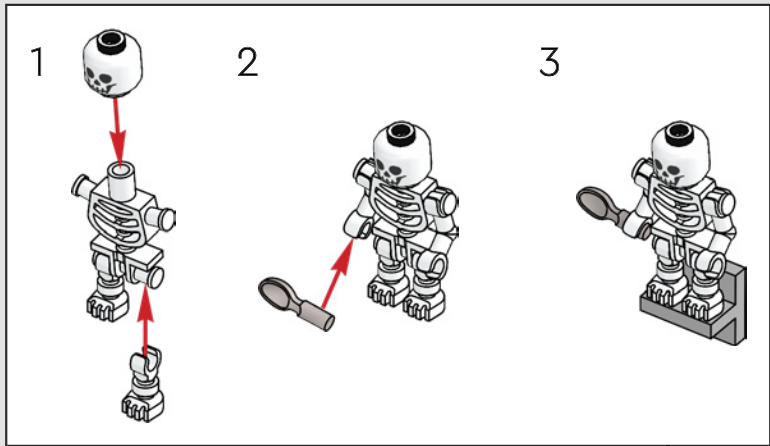

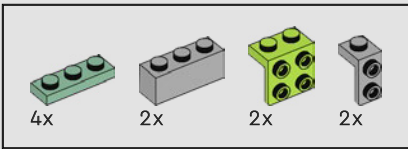

32

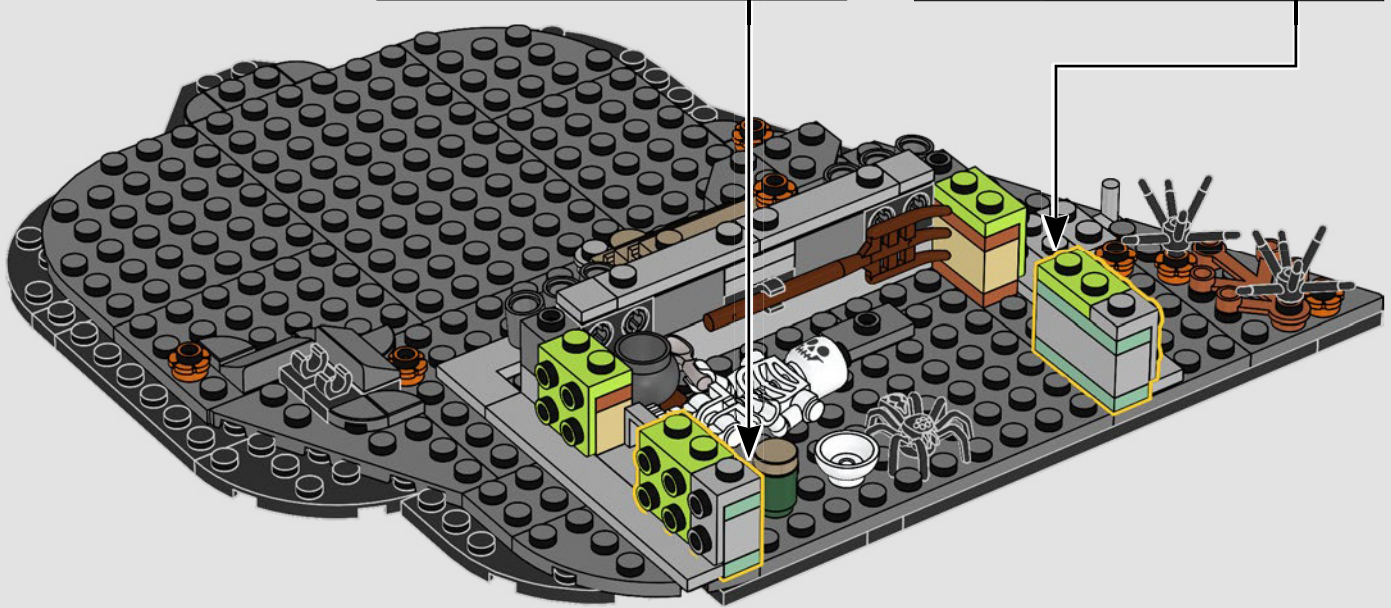
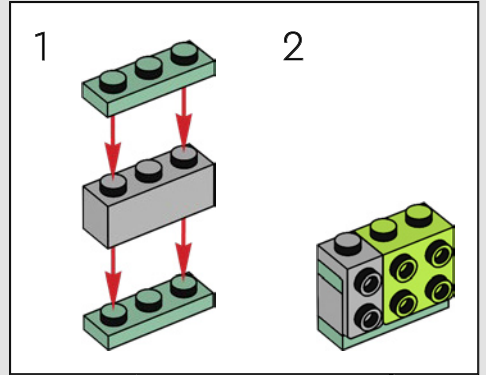
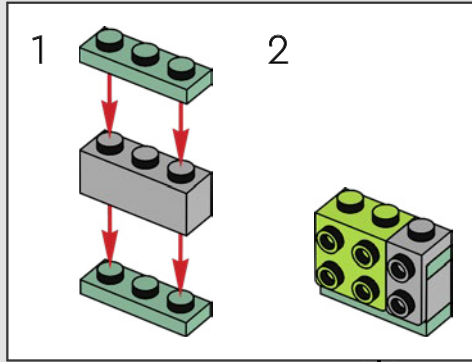

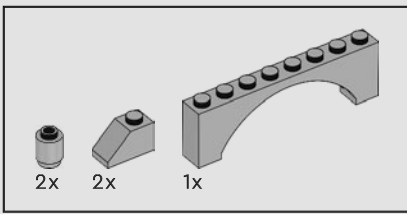

33

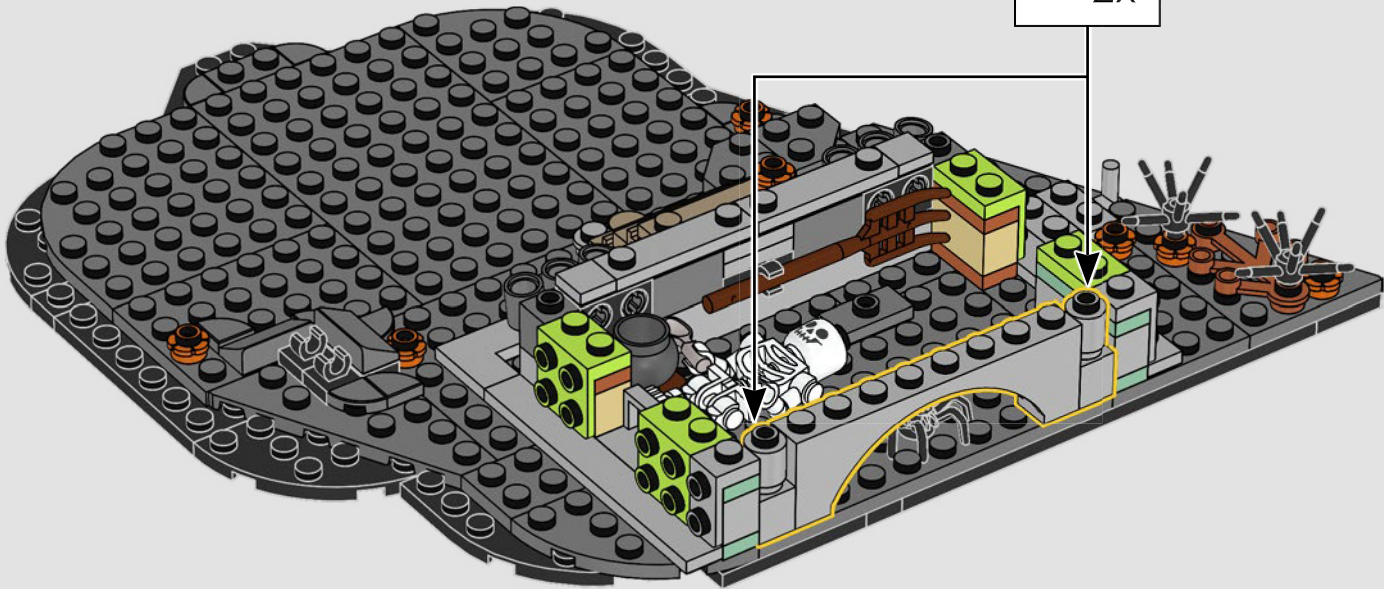
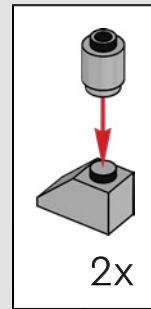

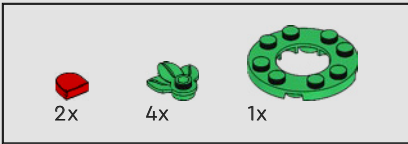

34

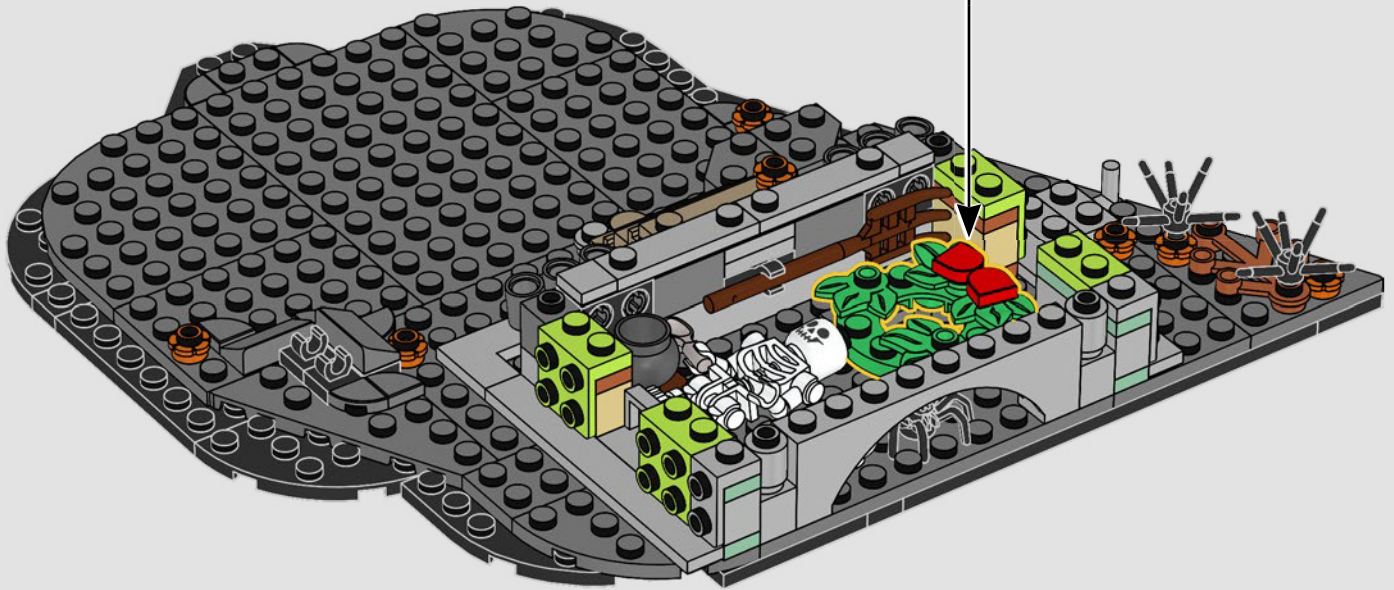
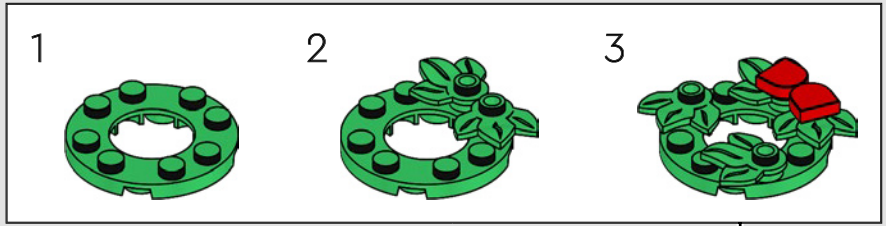



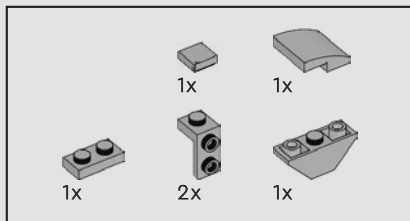

35

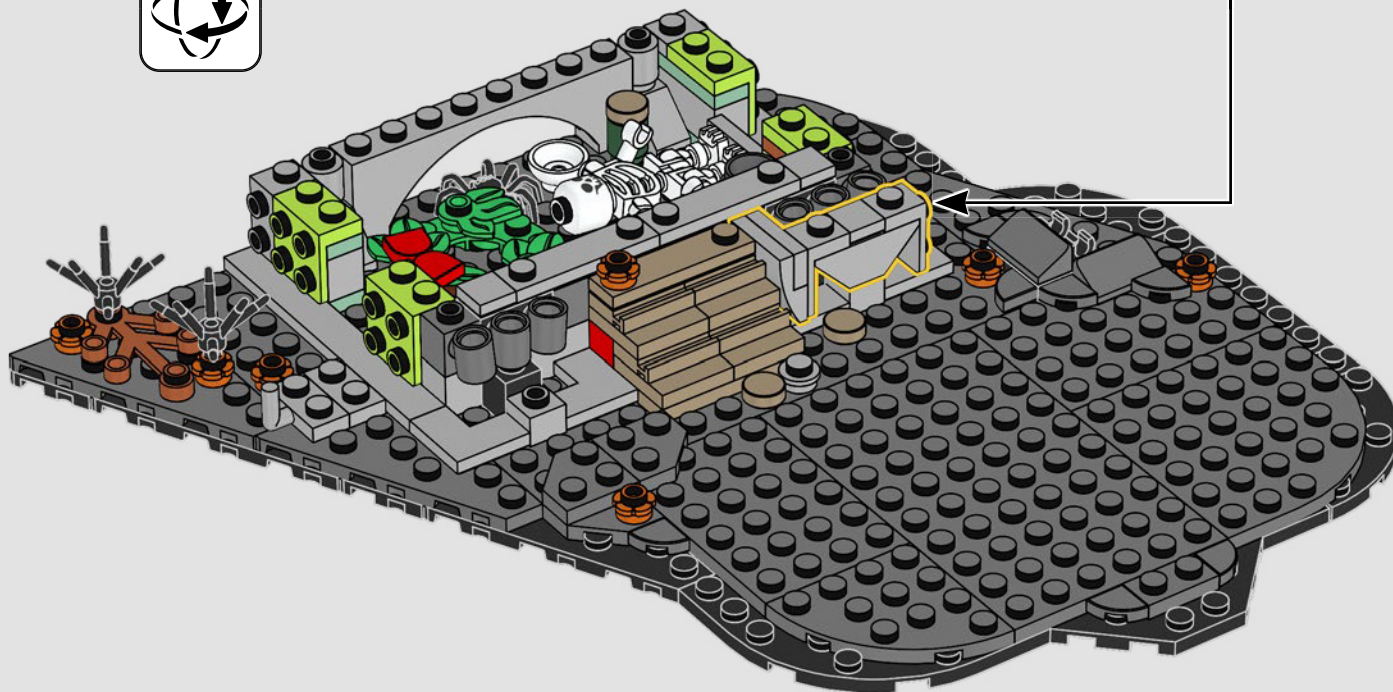
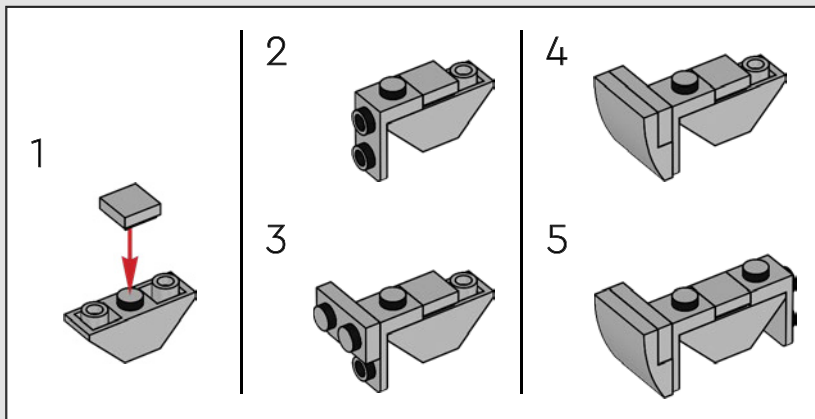

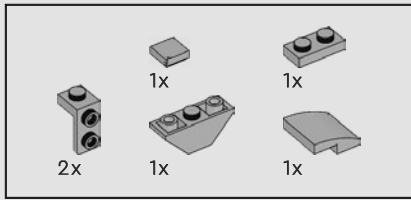

36

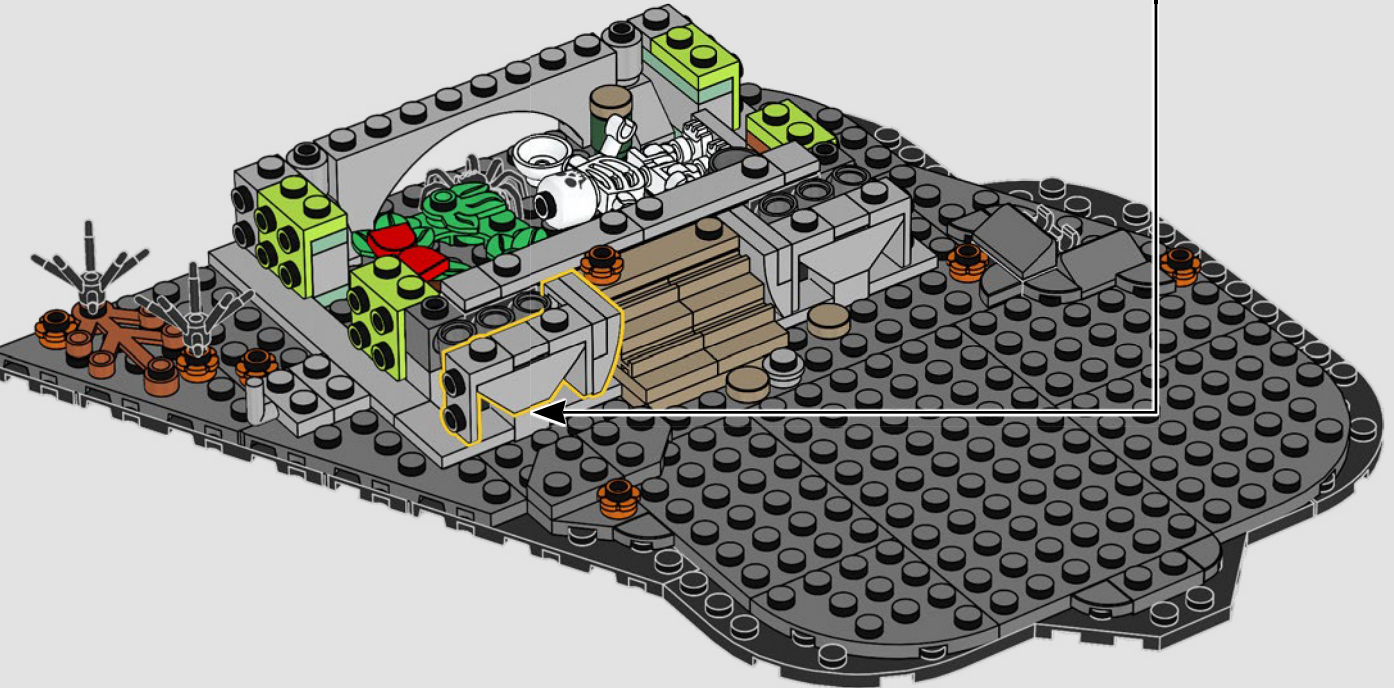
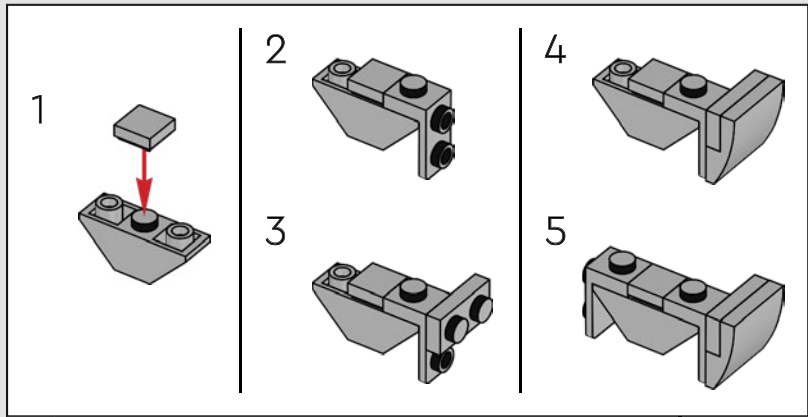

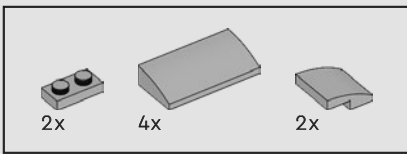

37

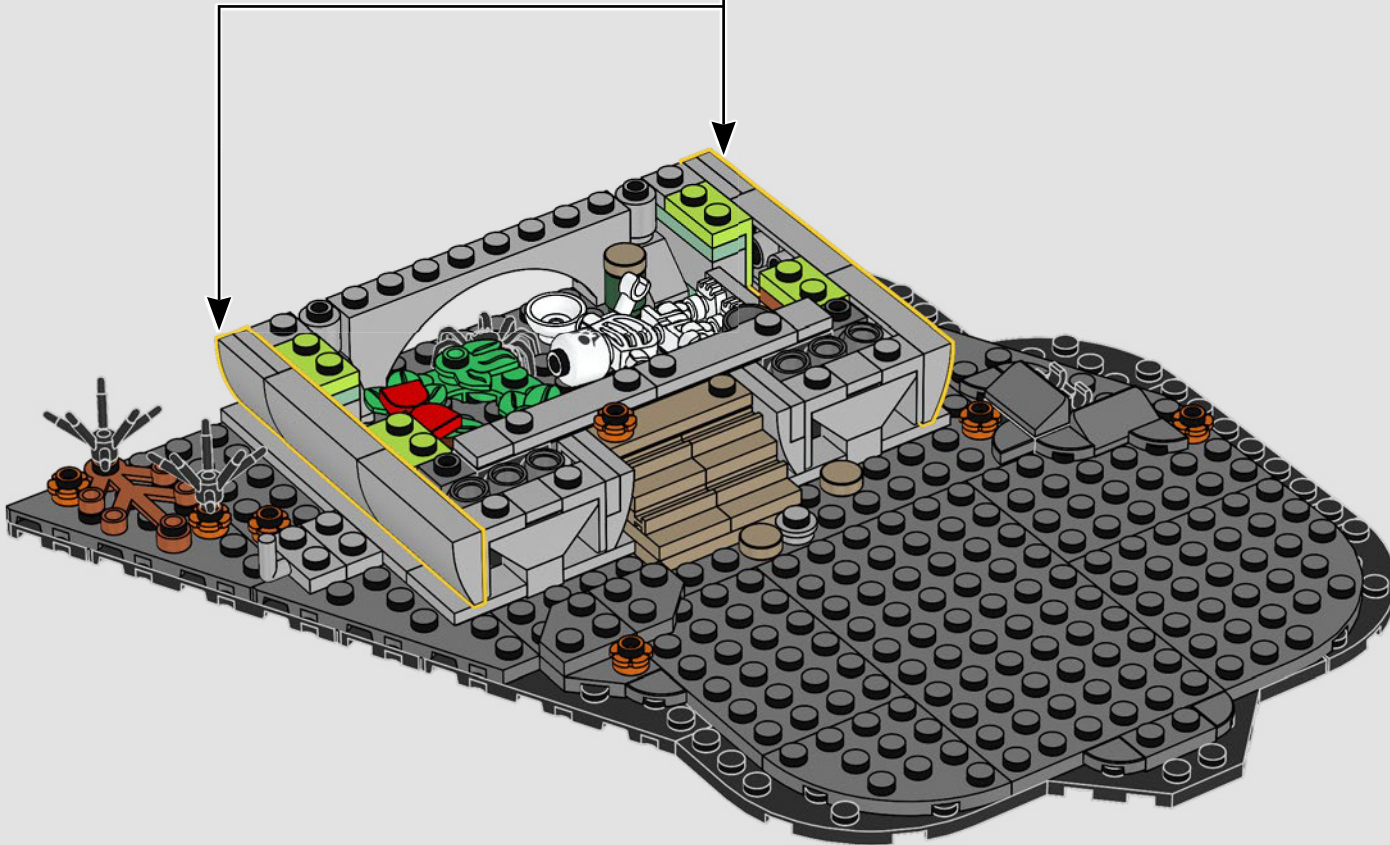
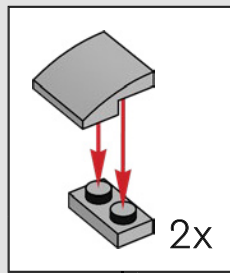

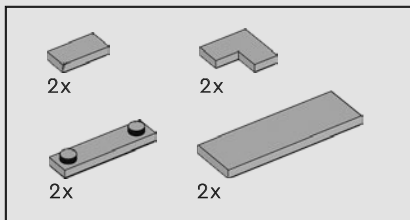

38

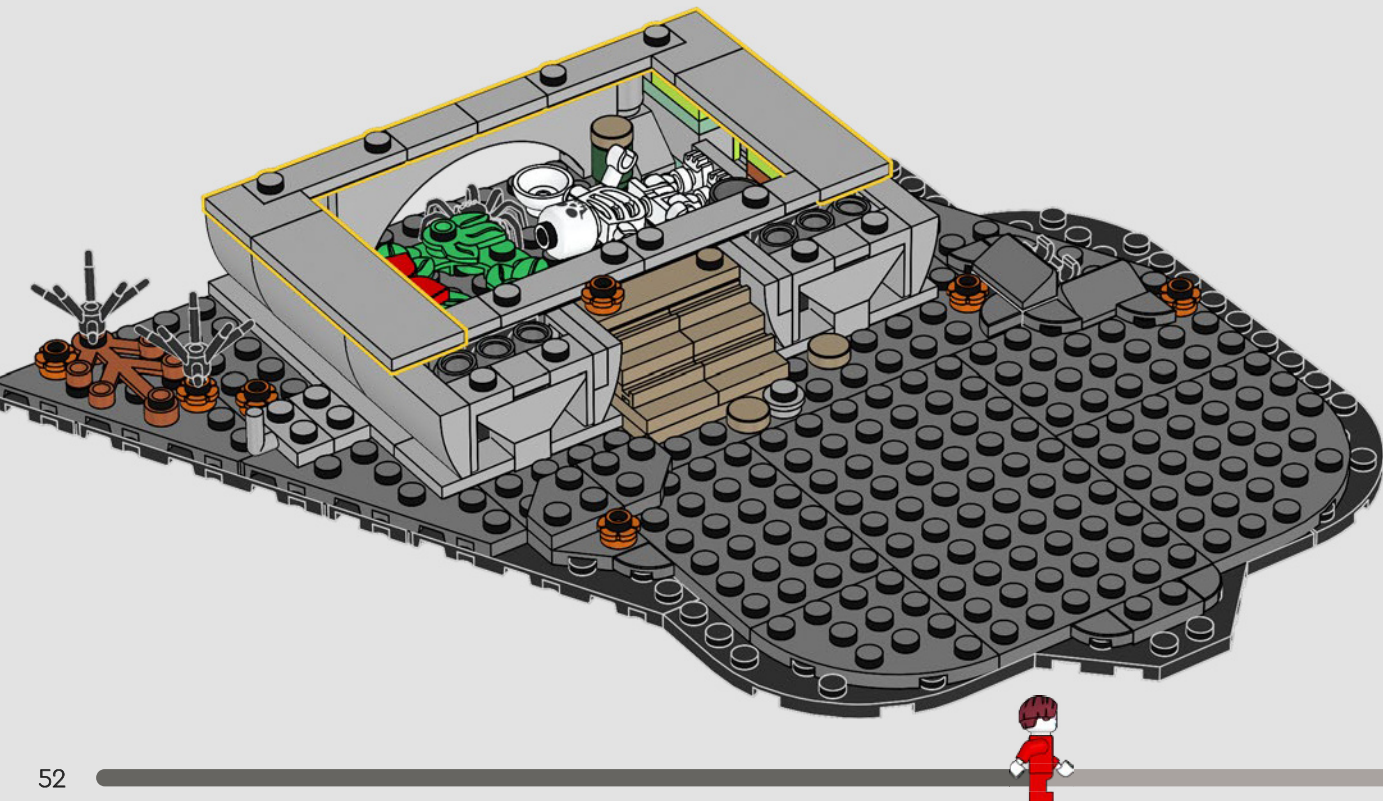

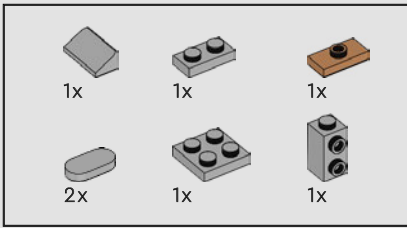

39

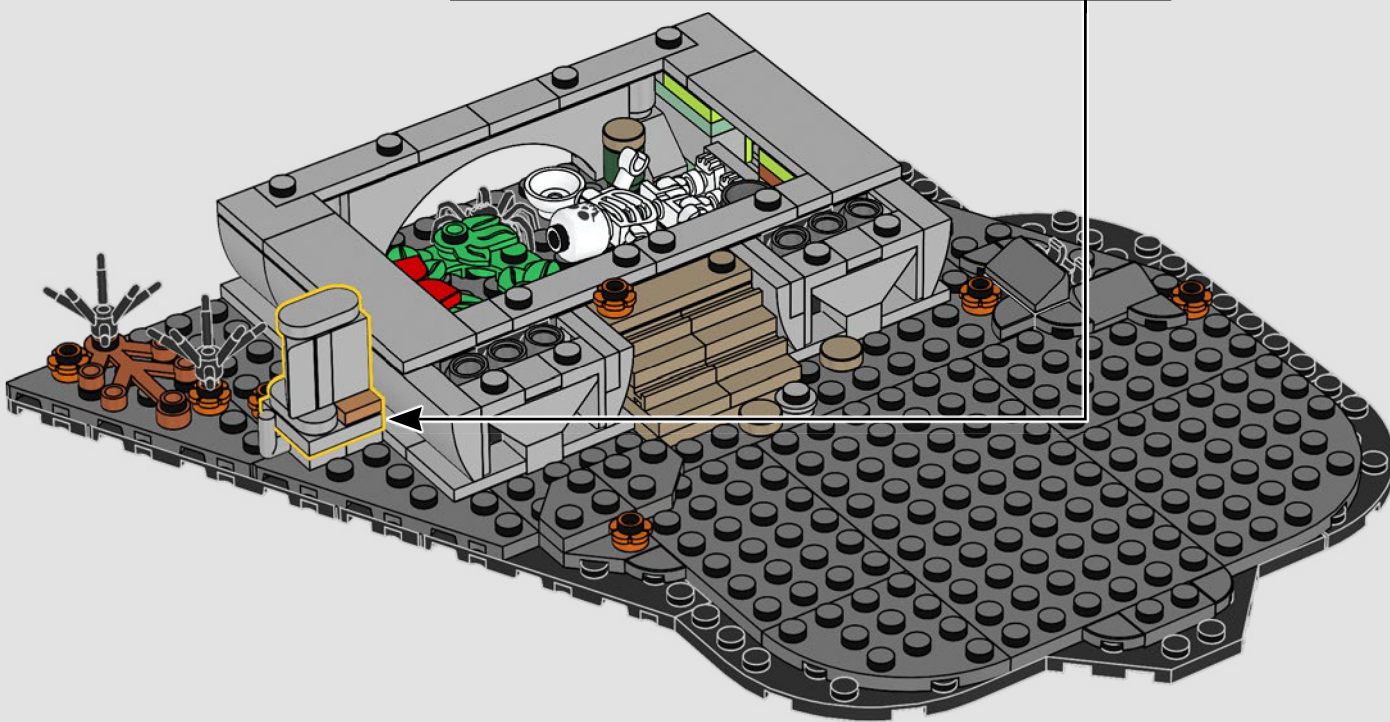
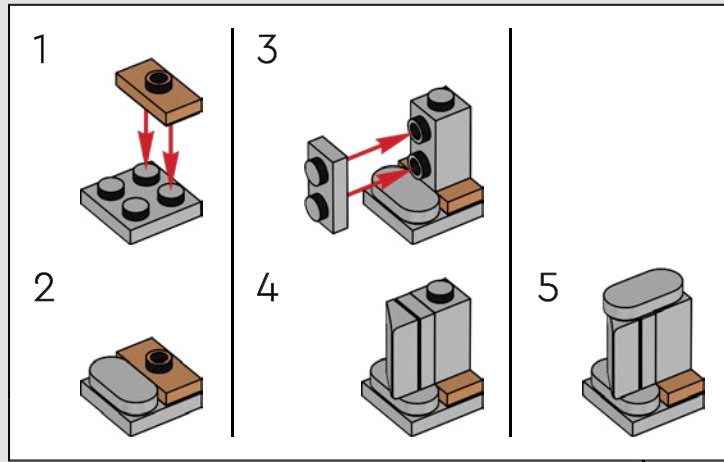

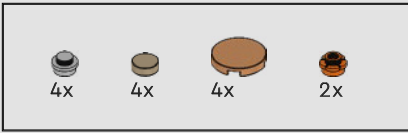

40

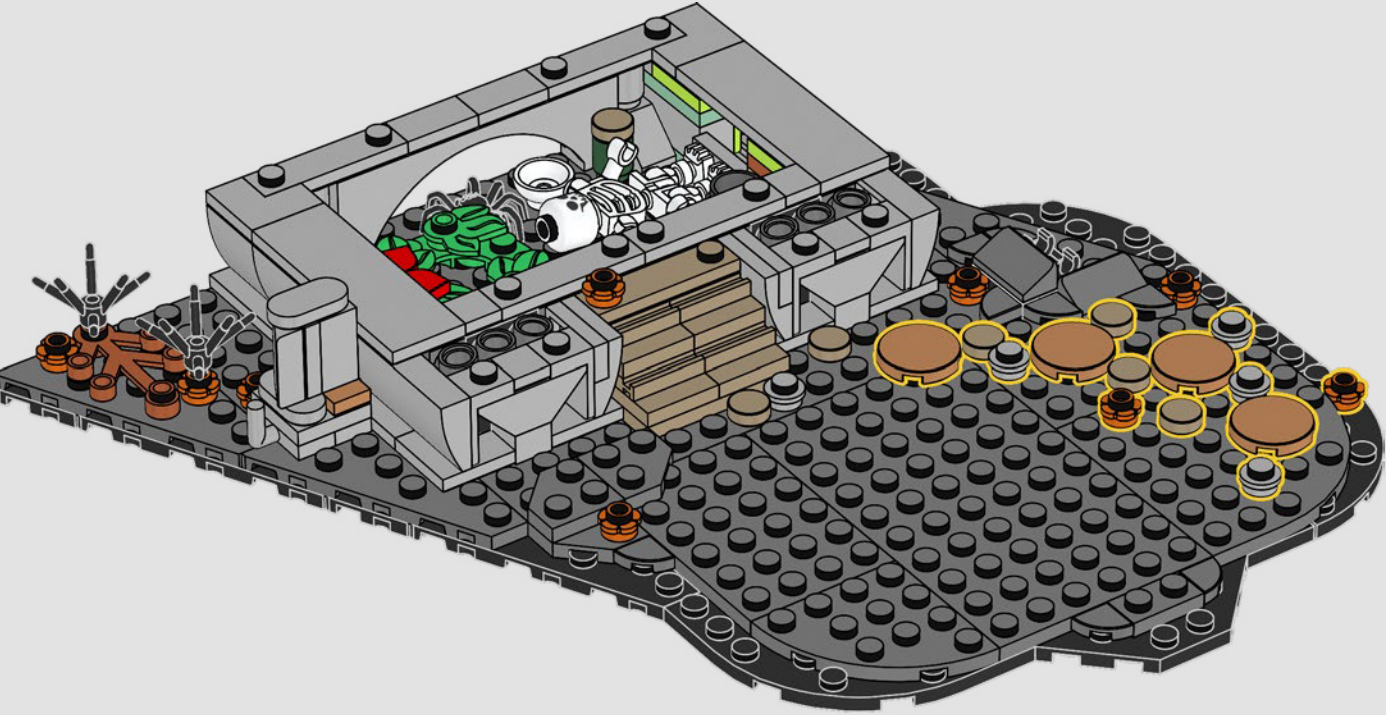



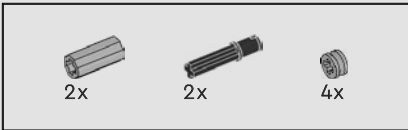

41

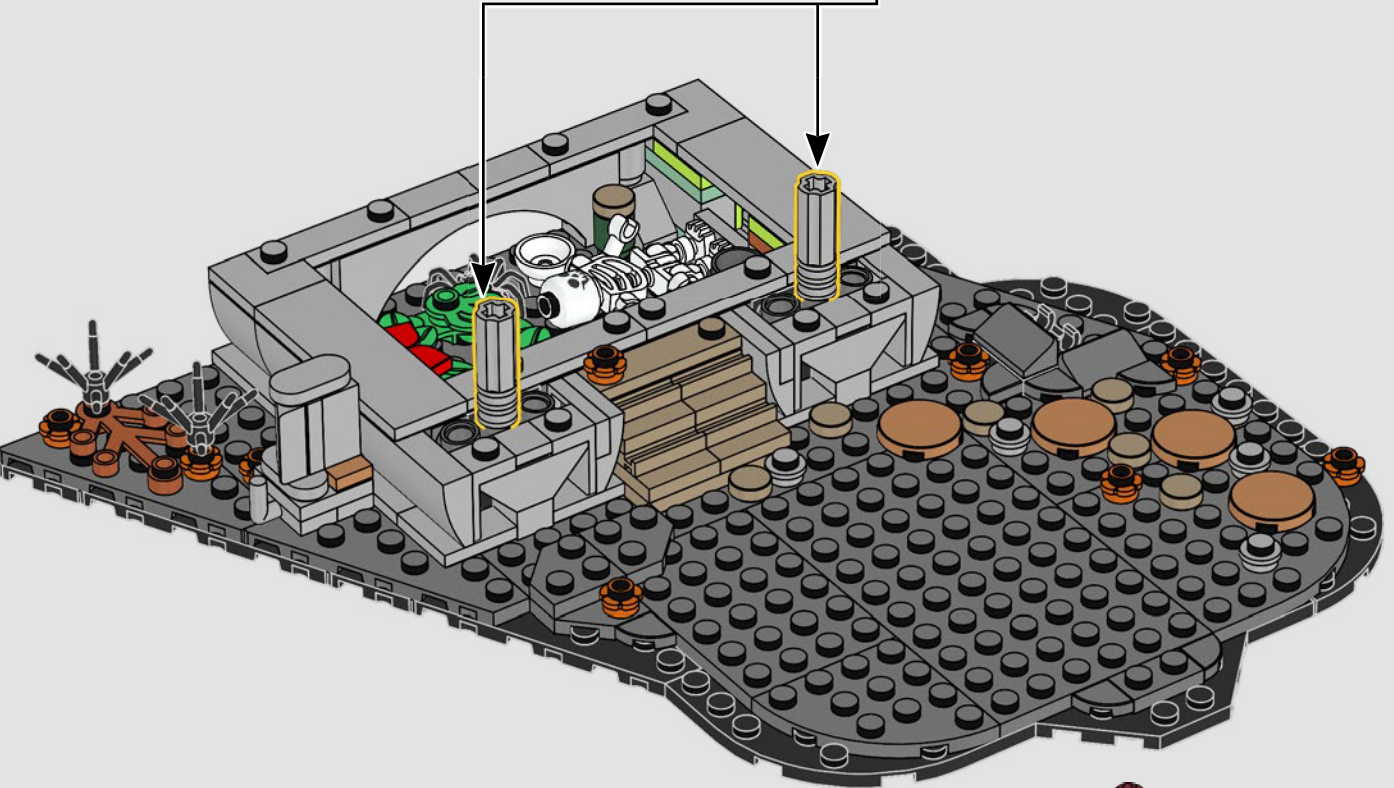
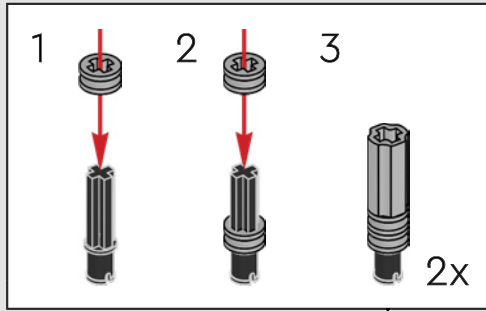



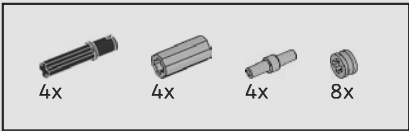

42

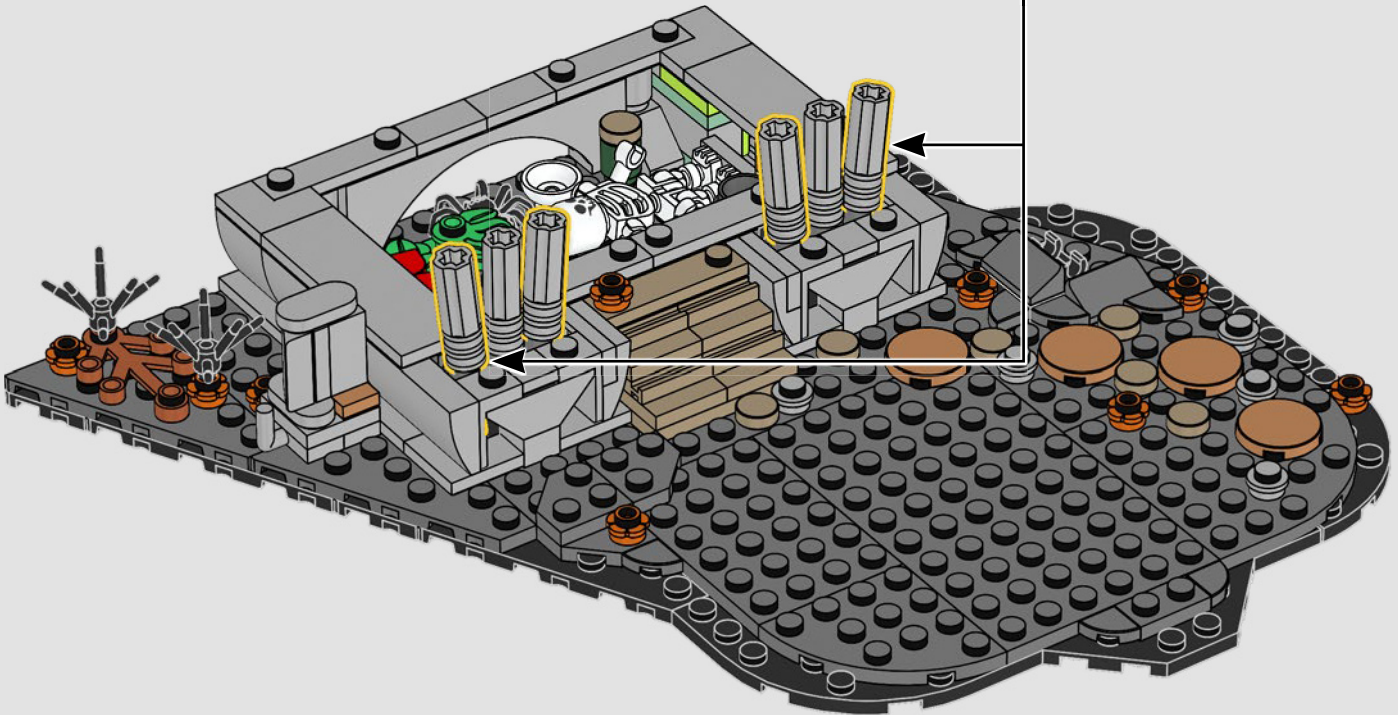
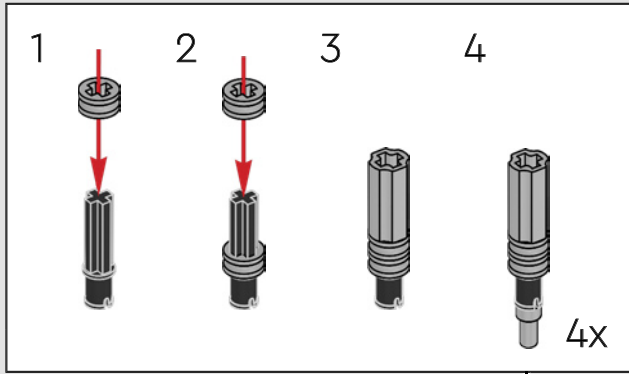

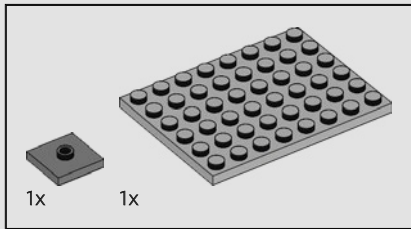
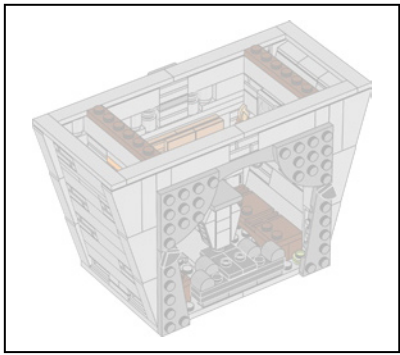

43

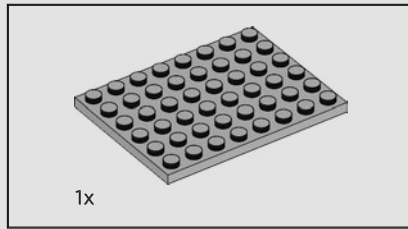
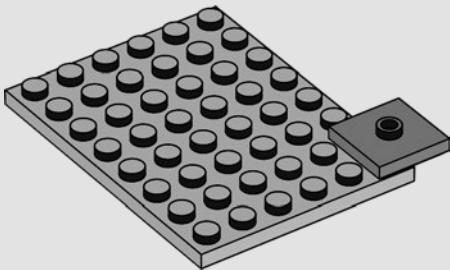

44

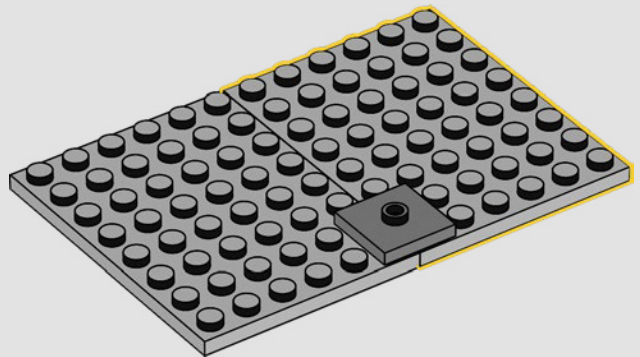

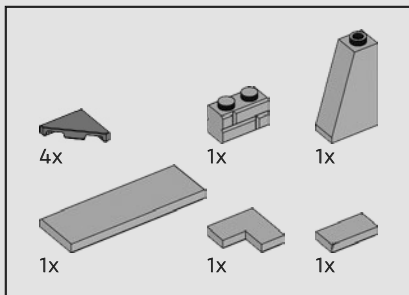

45

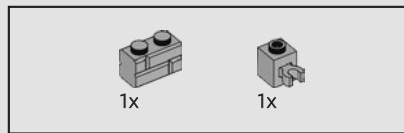
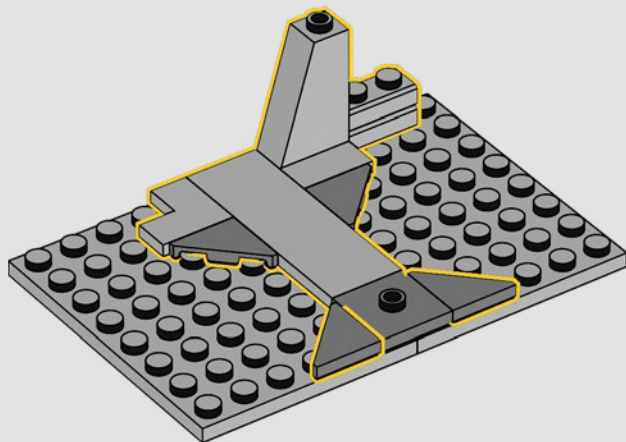

46

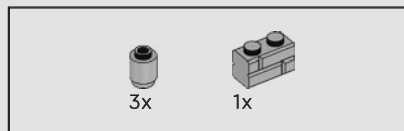
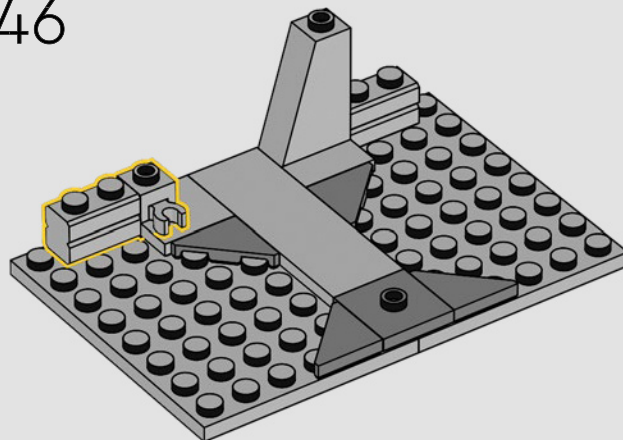

47

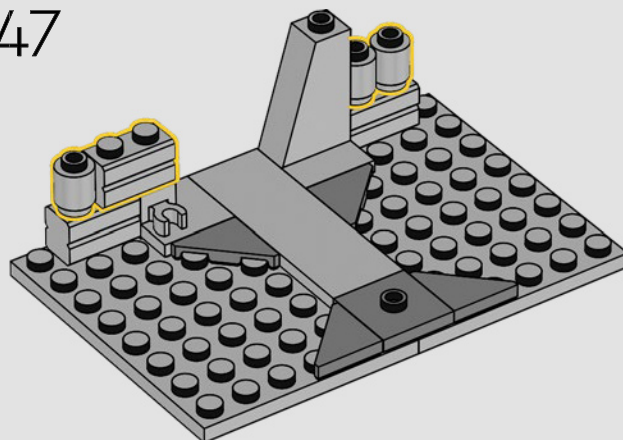

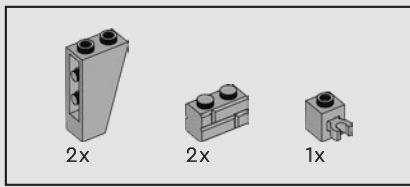

48

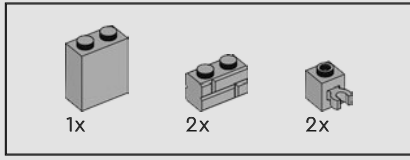
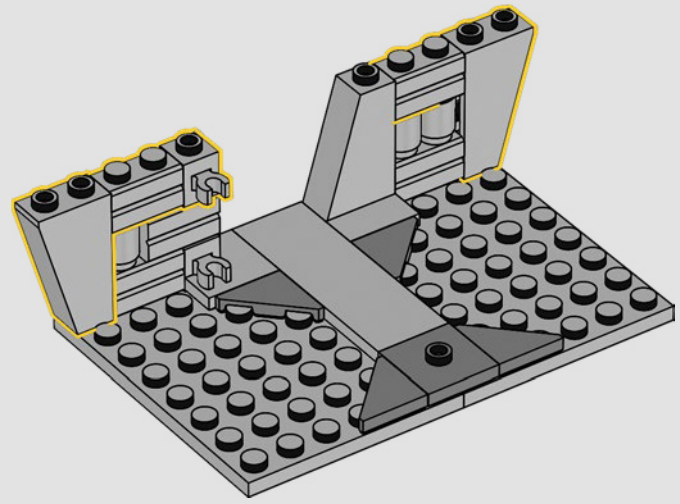

49

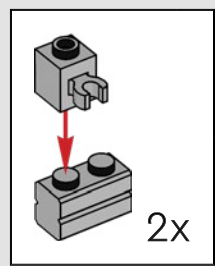
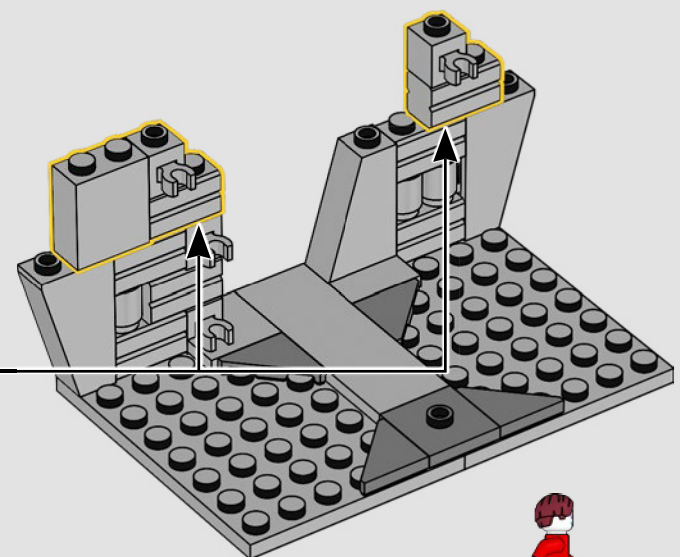

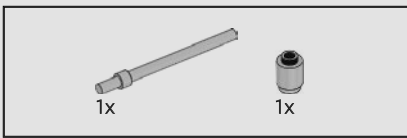

50

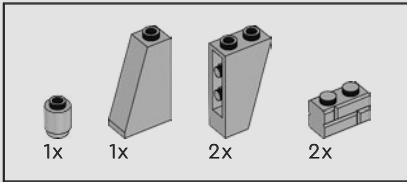
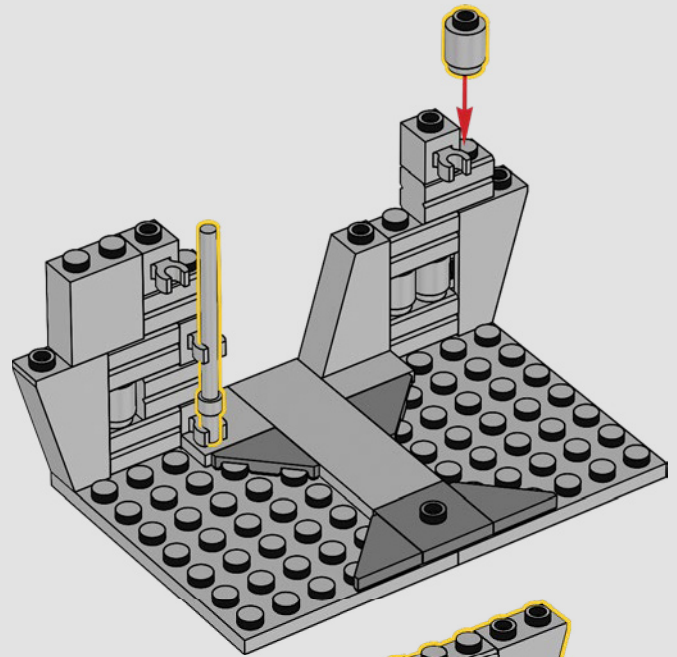

51

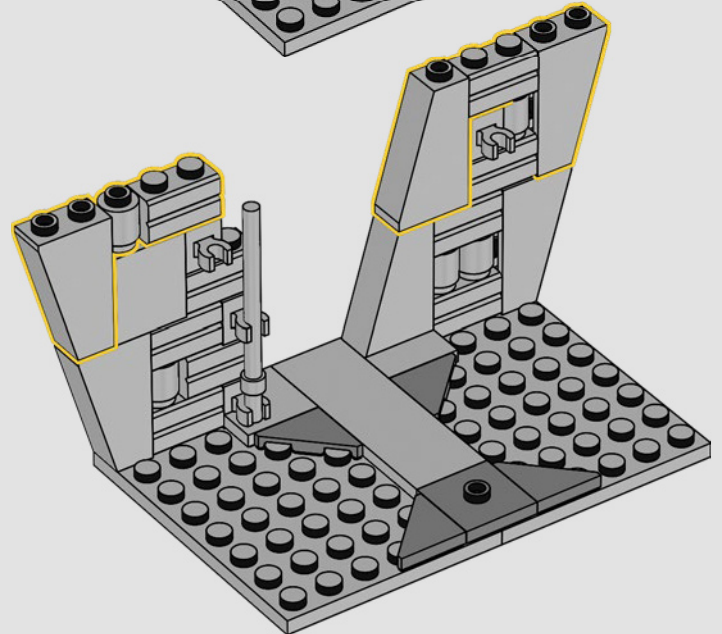

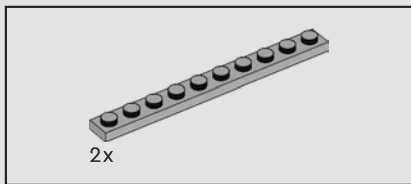

52

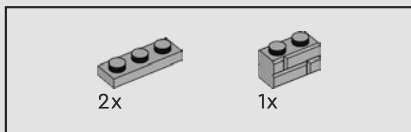
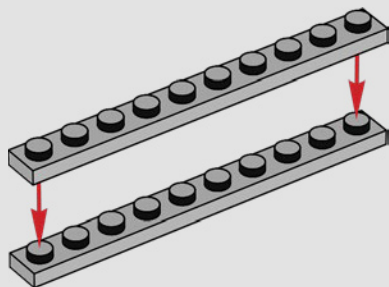

53

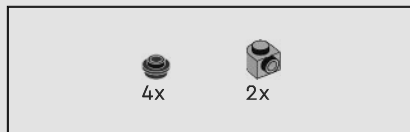
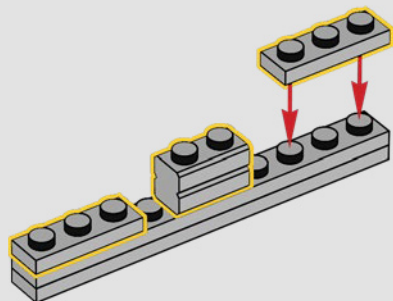

54

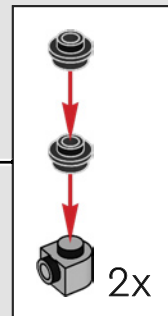
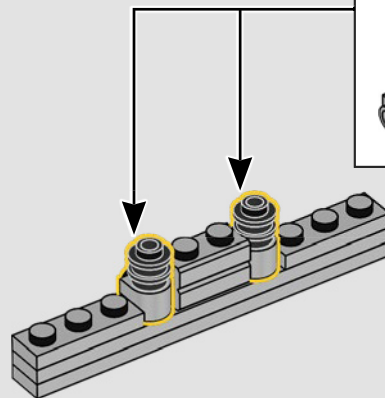

55

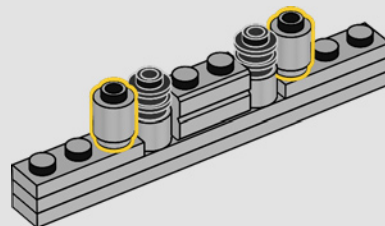

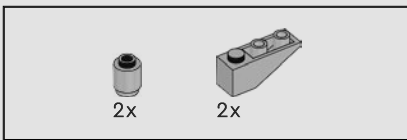

56

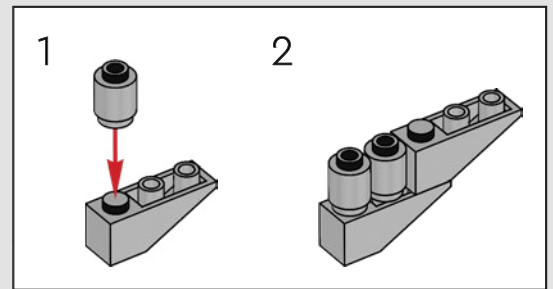
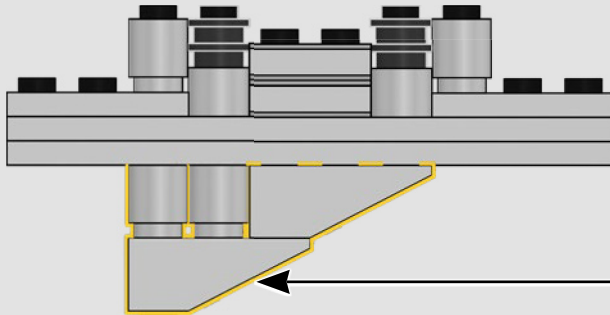

57

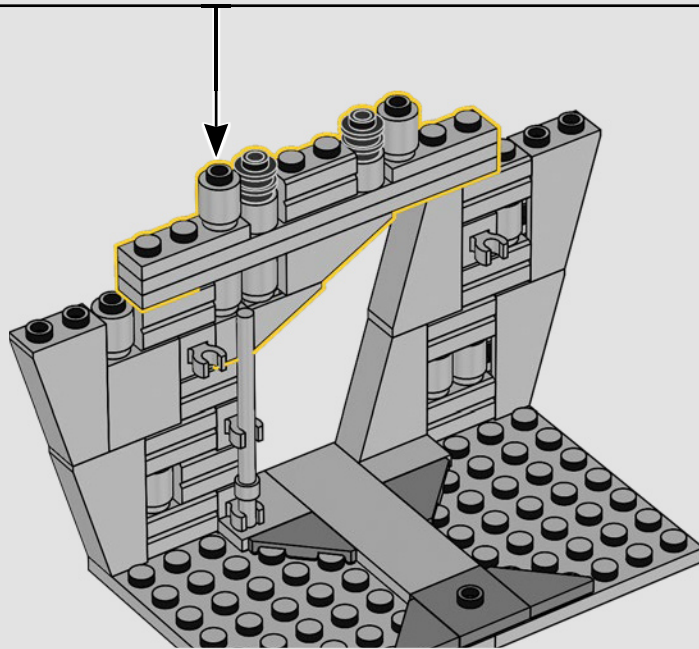

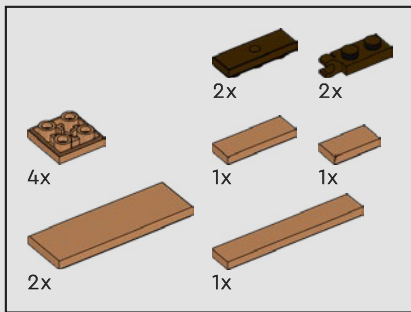

58

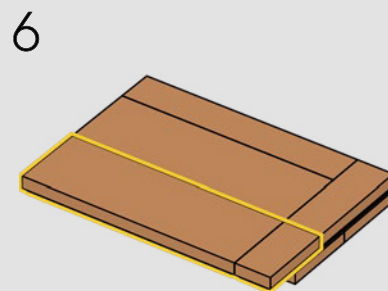
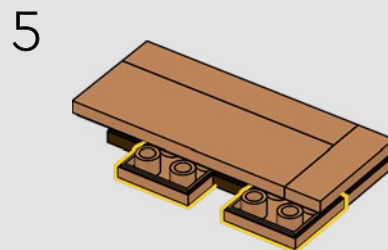
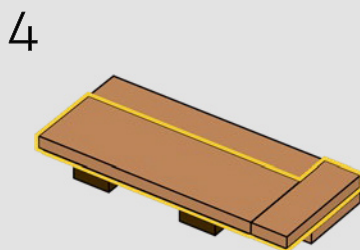
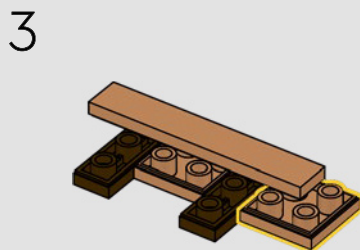
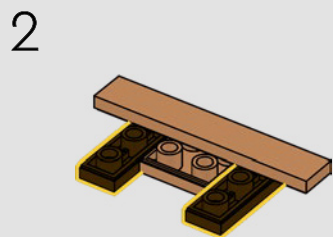
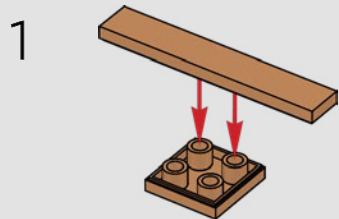



7

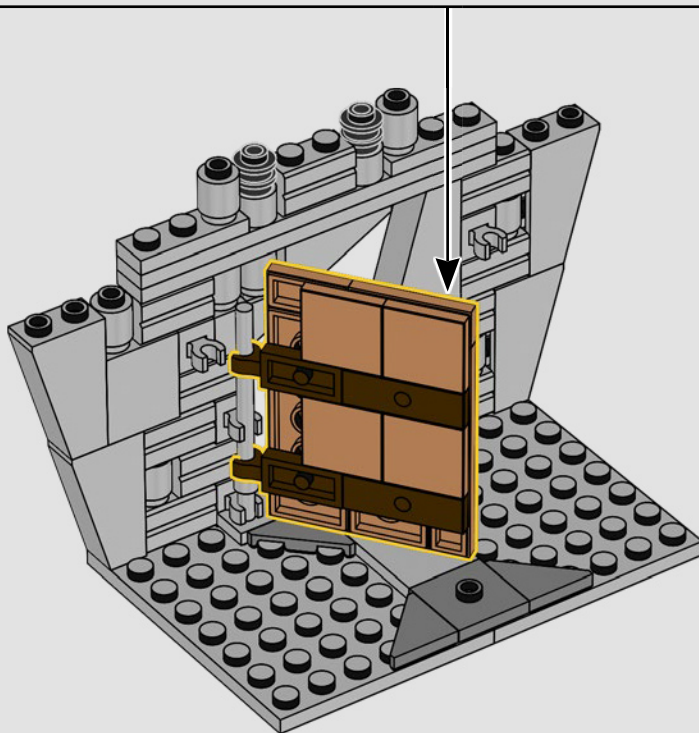
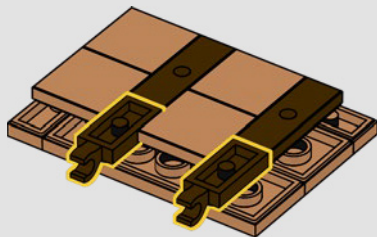



59

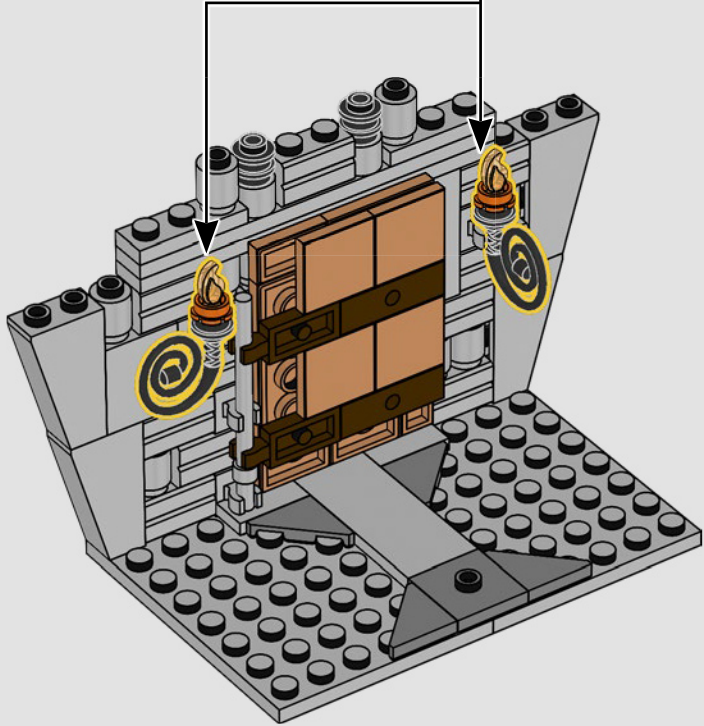
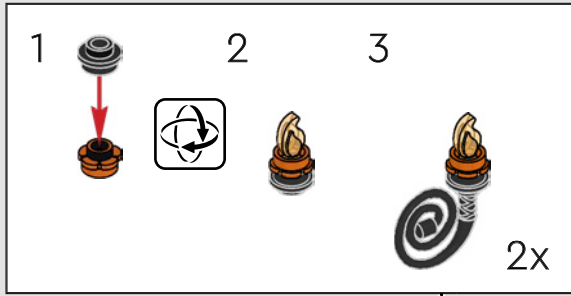

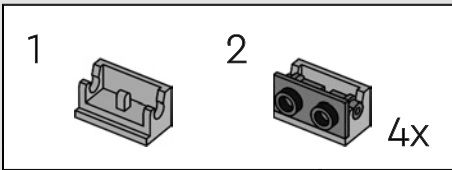
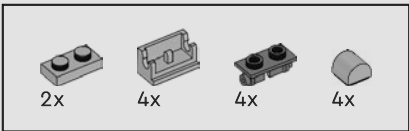

60

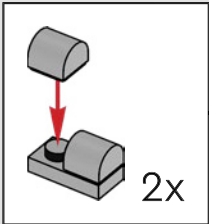
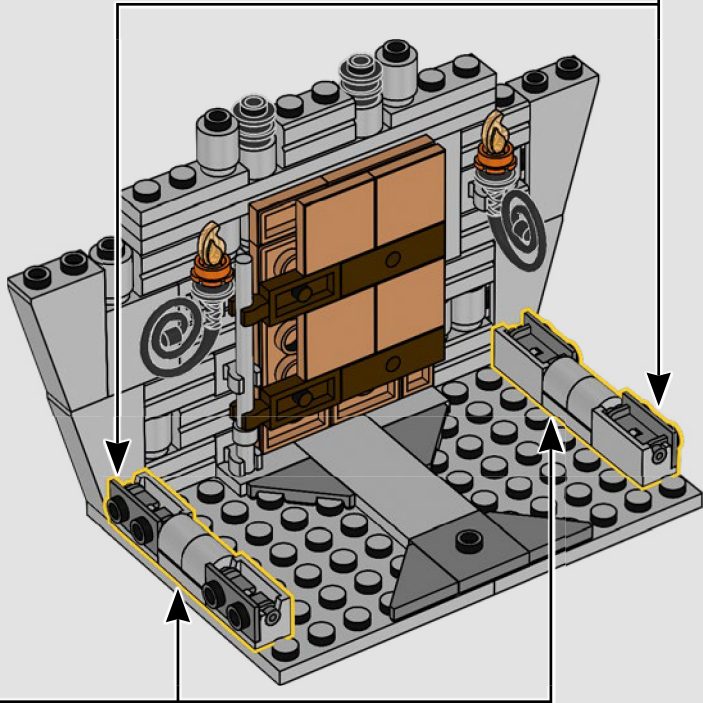

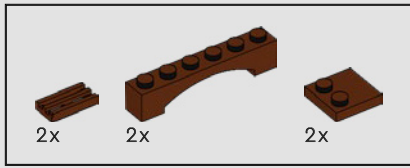

61

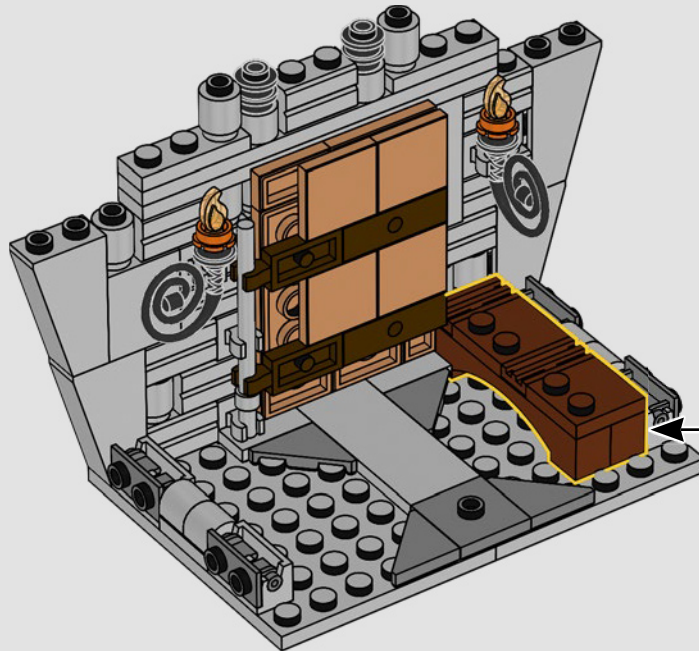
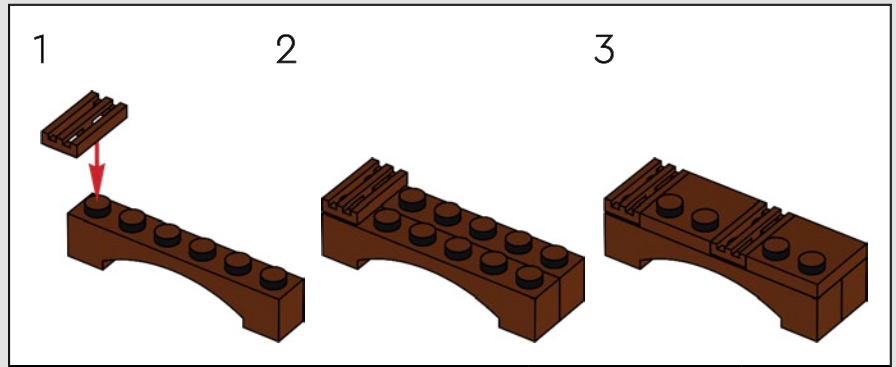

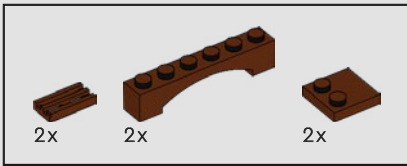

62

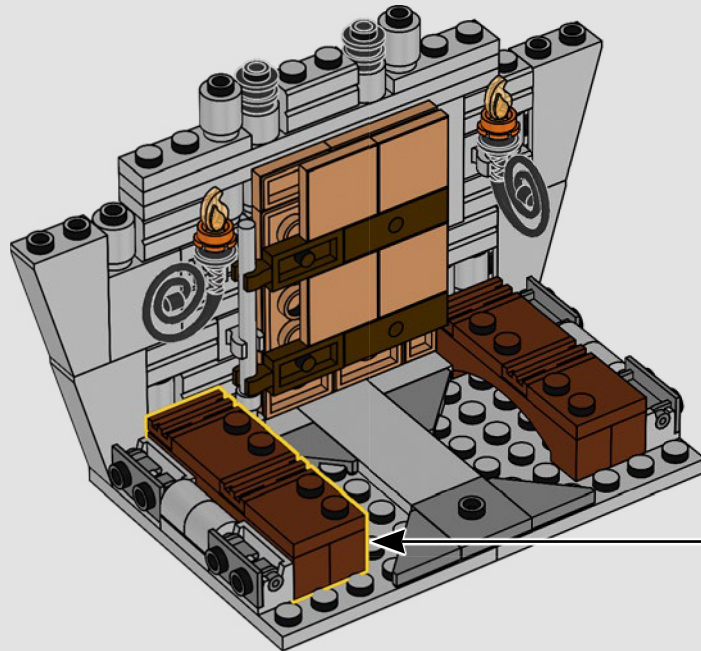
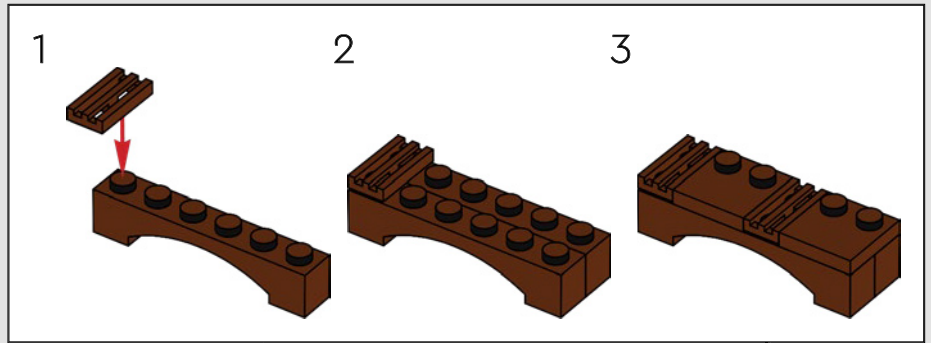

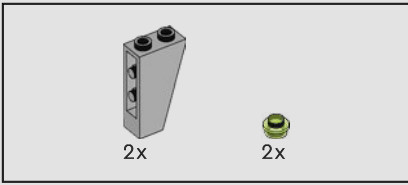

63

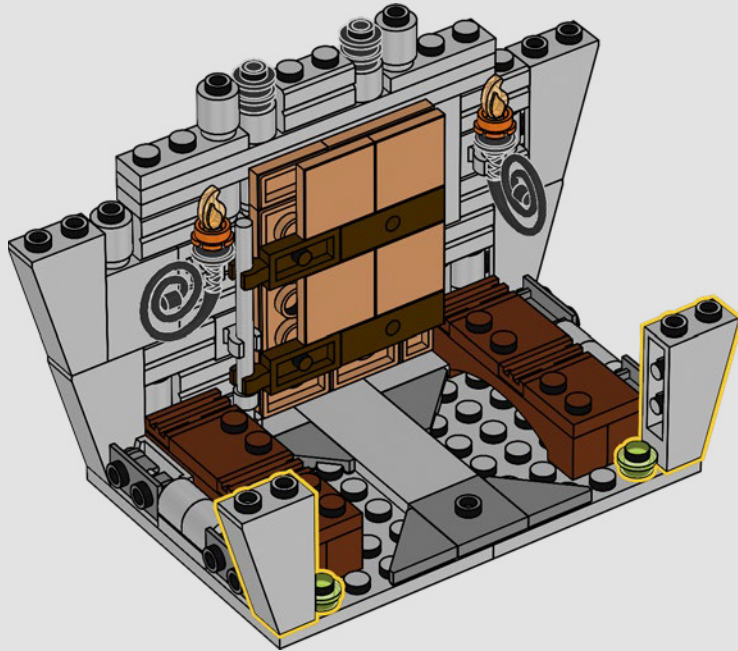



64

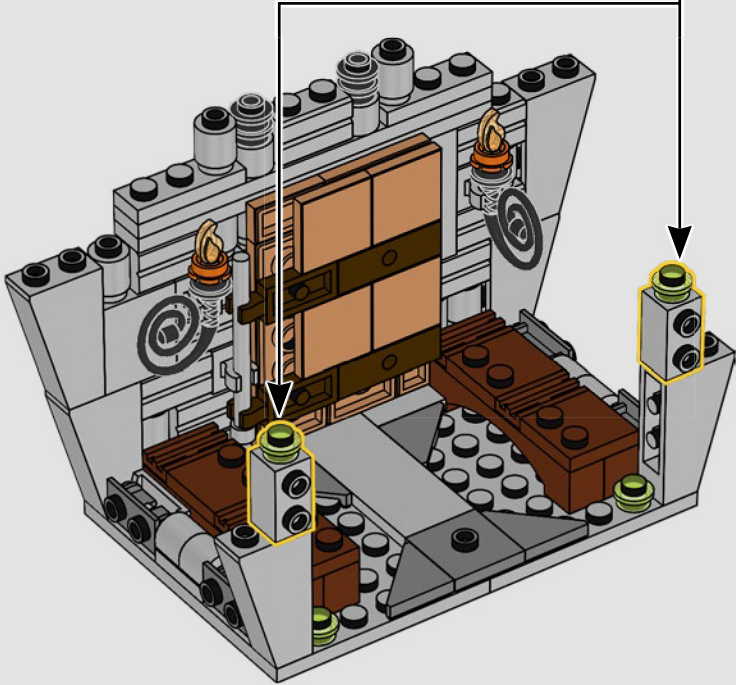
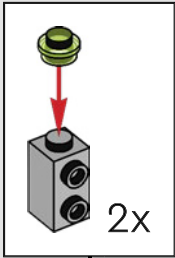

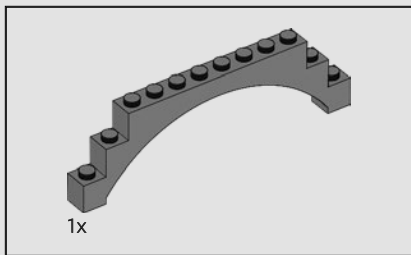

65

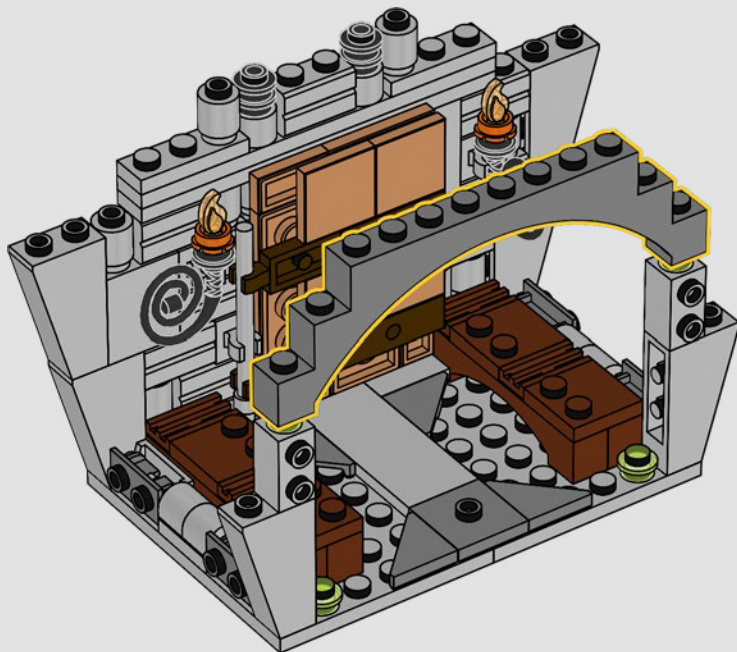



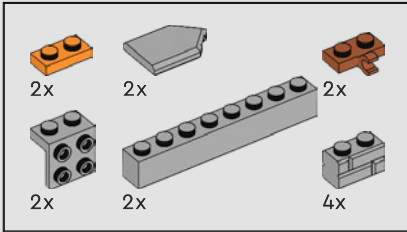
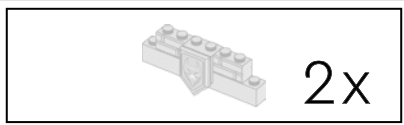

66

1

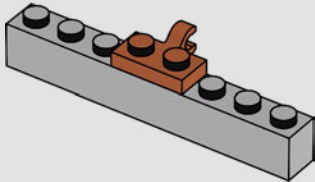

2

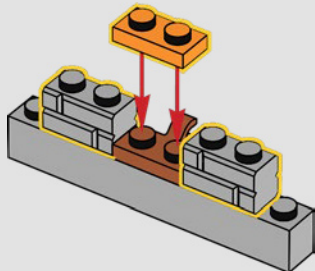

3

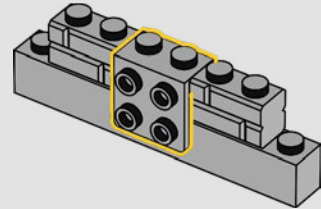

4

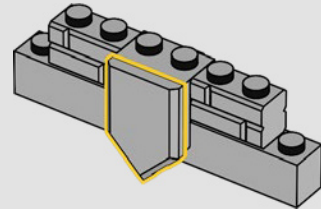

5

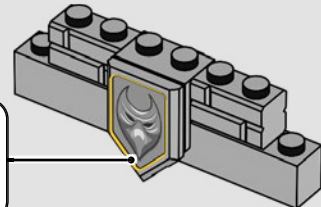

2x



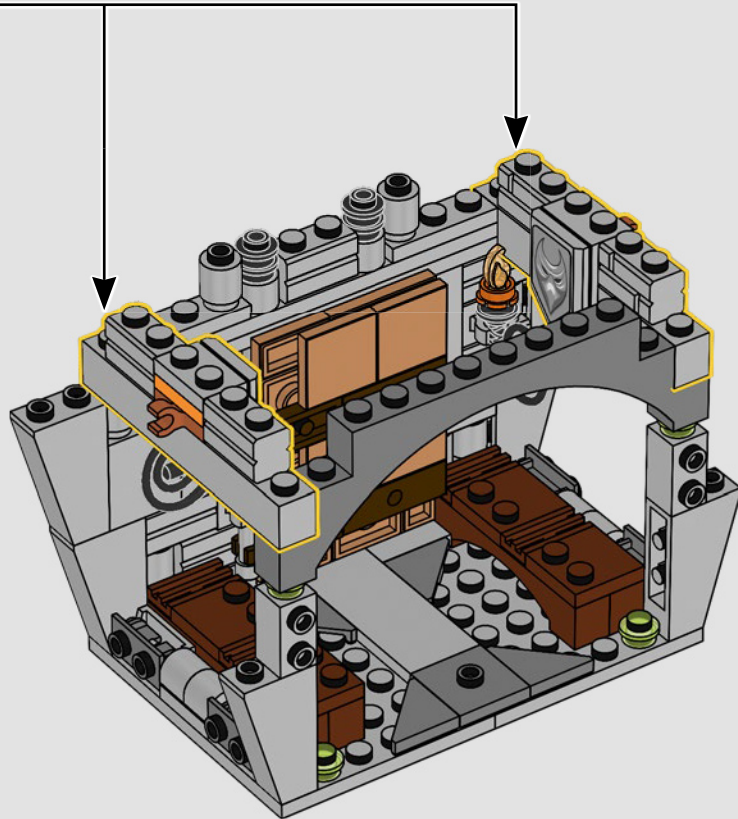

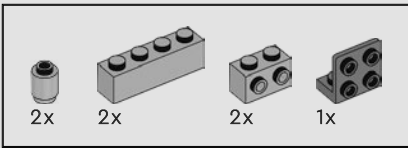

67

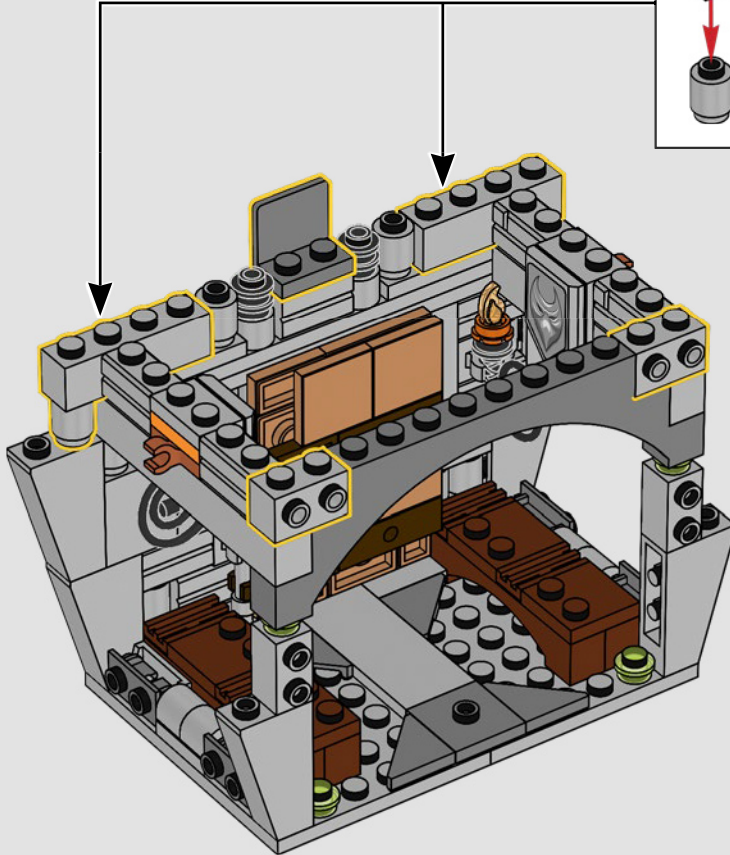
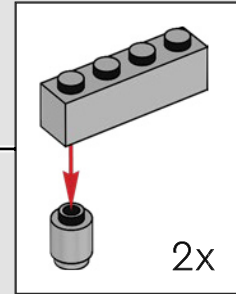

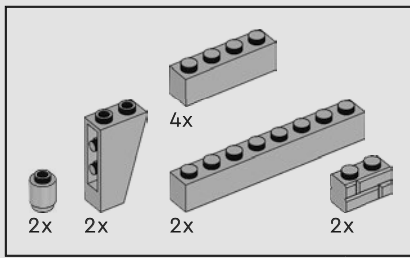

68

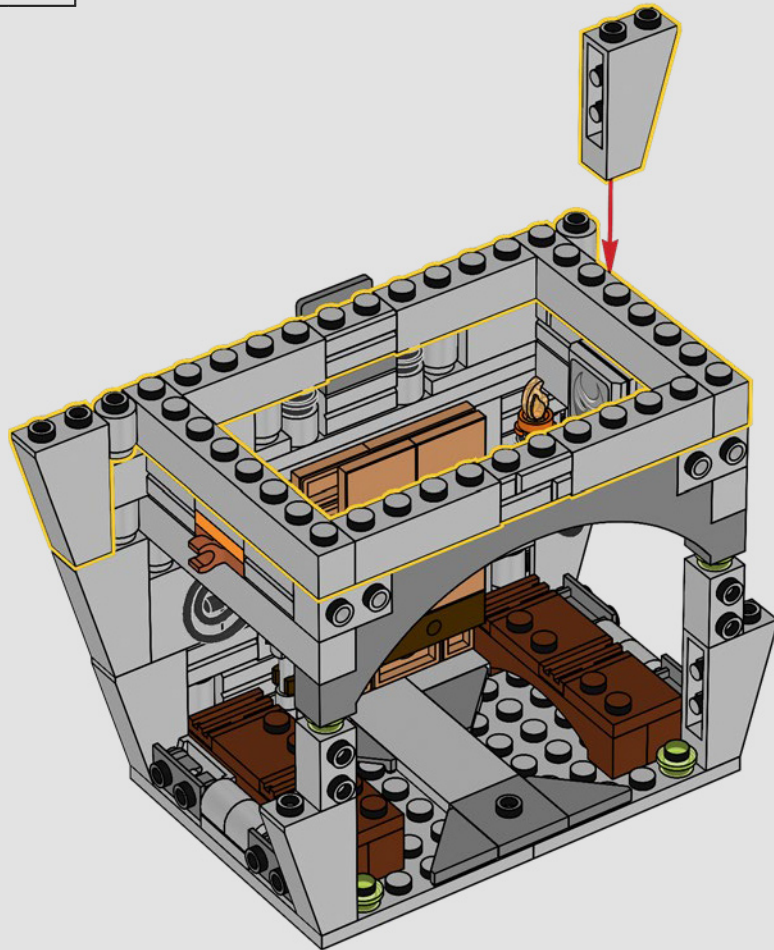

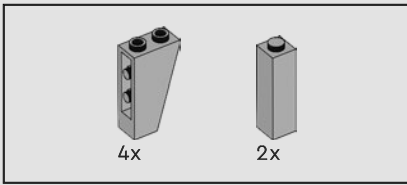

69

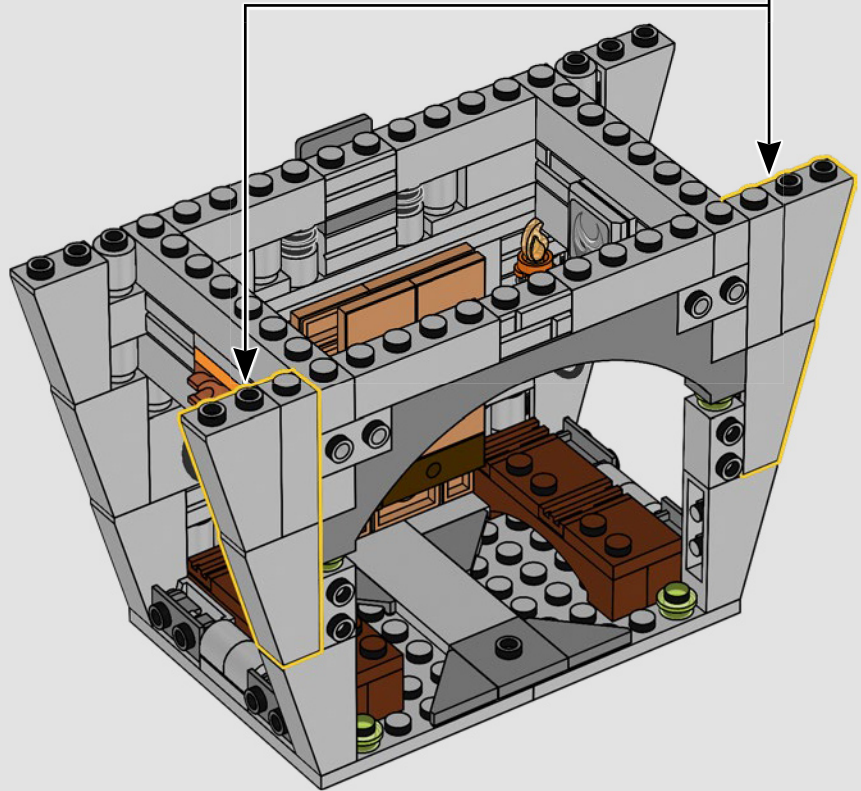
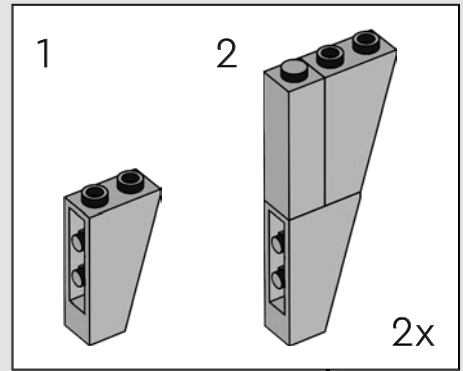

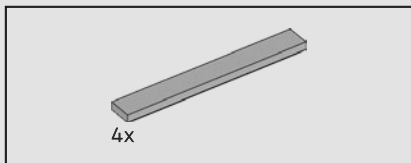

70

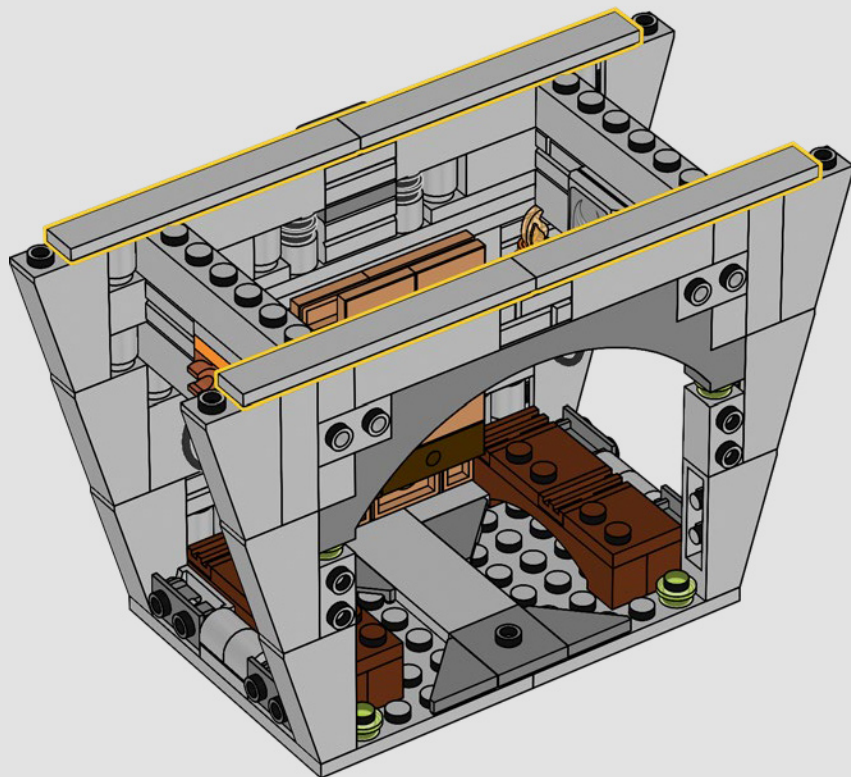

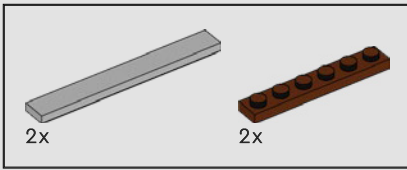

71

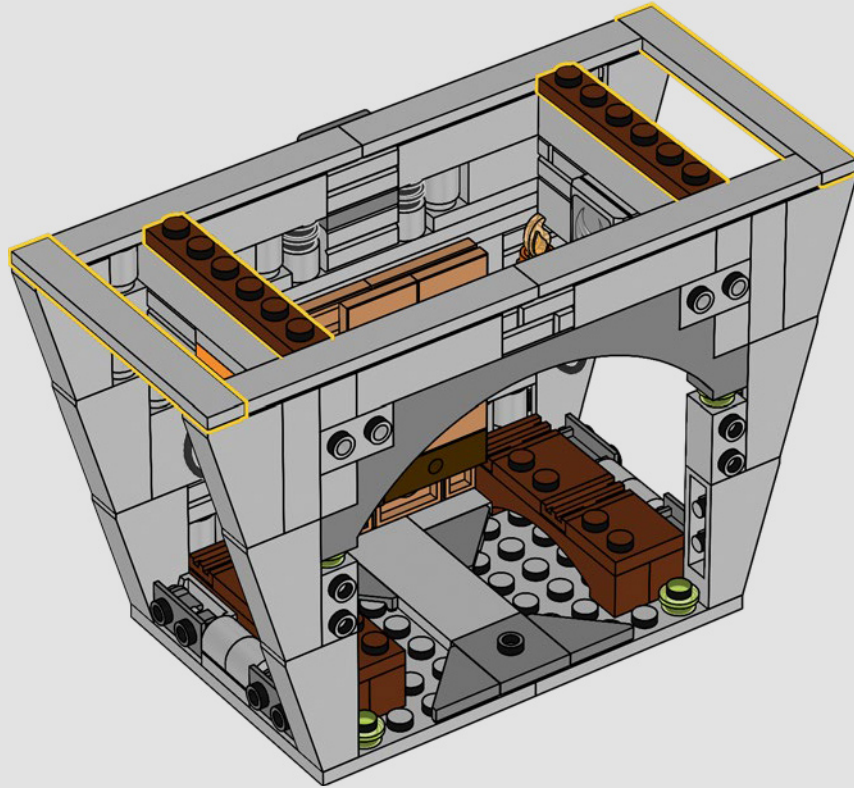

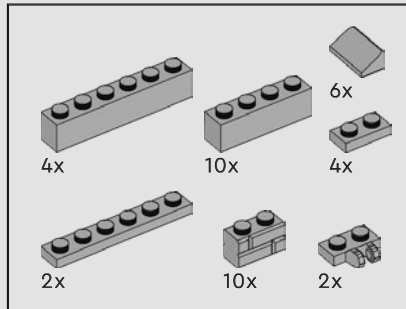
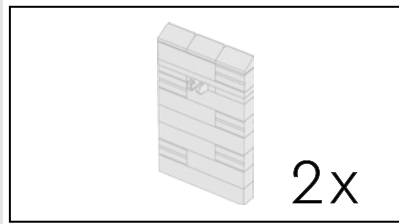

72

1

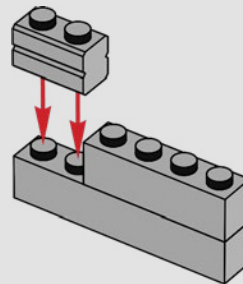



2

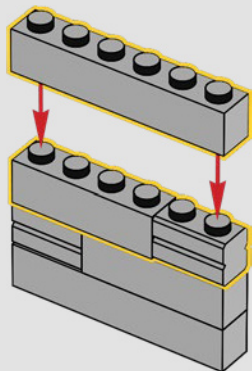

3

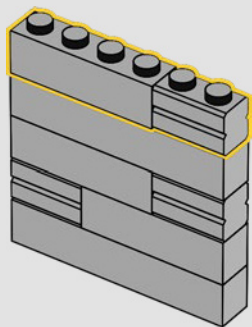

4

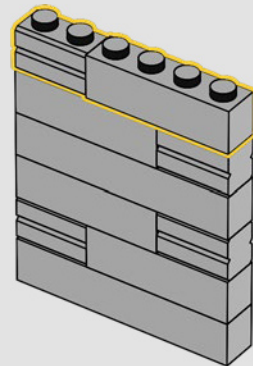

5

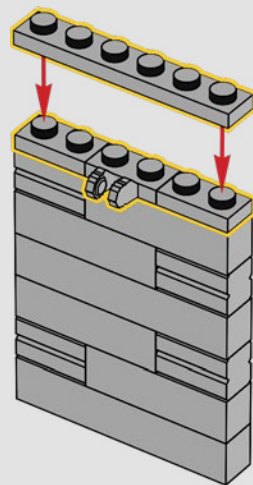

6

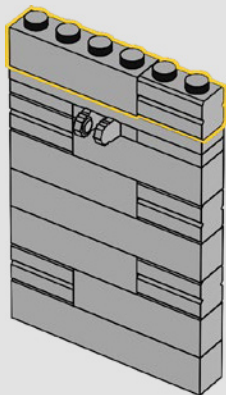

7

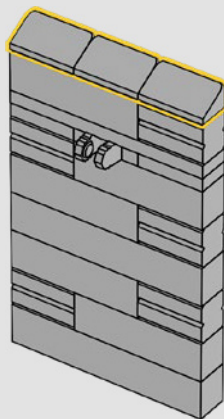

2x

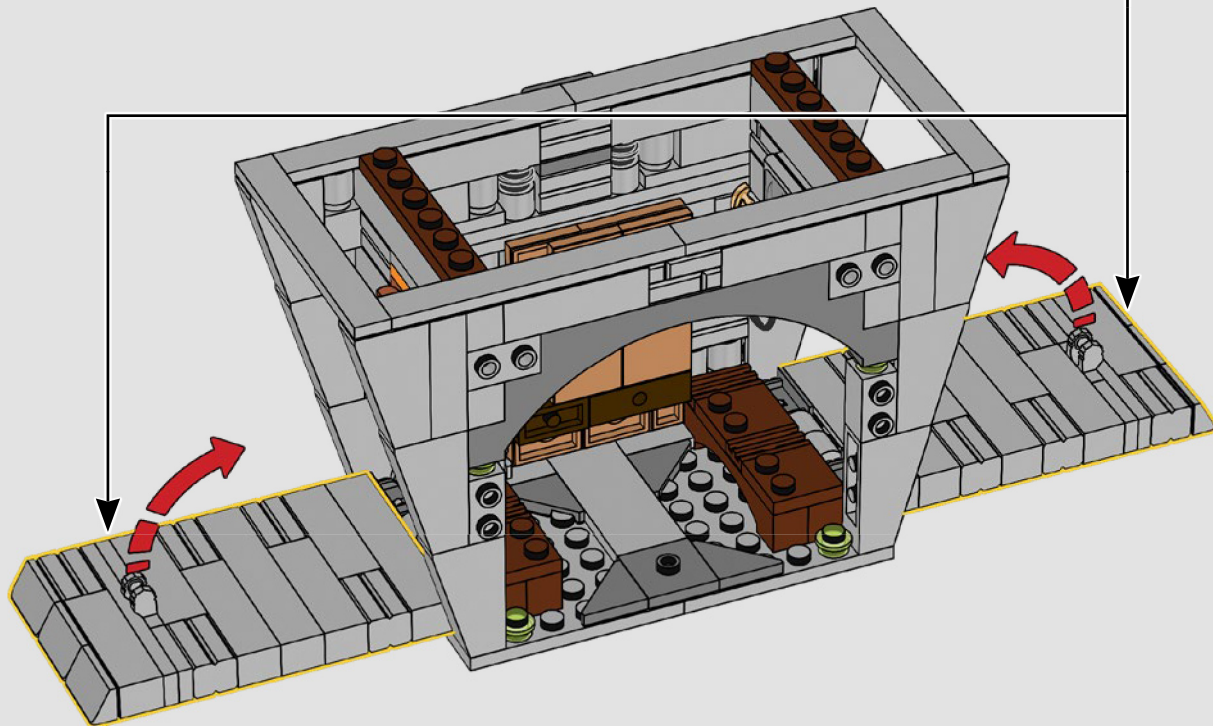

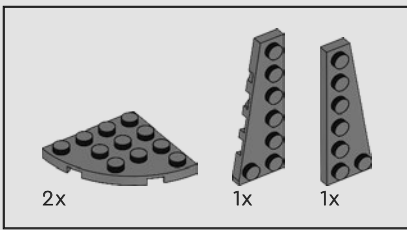

73

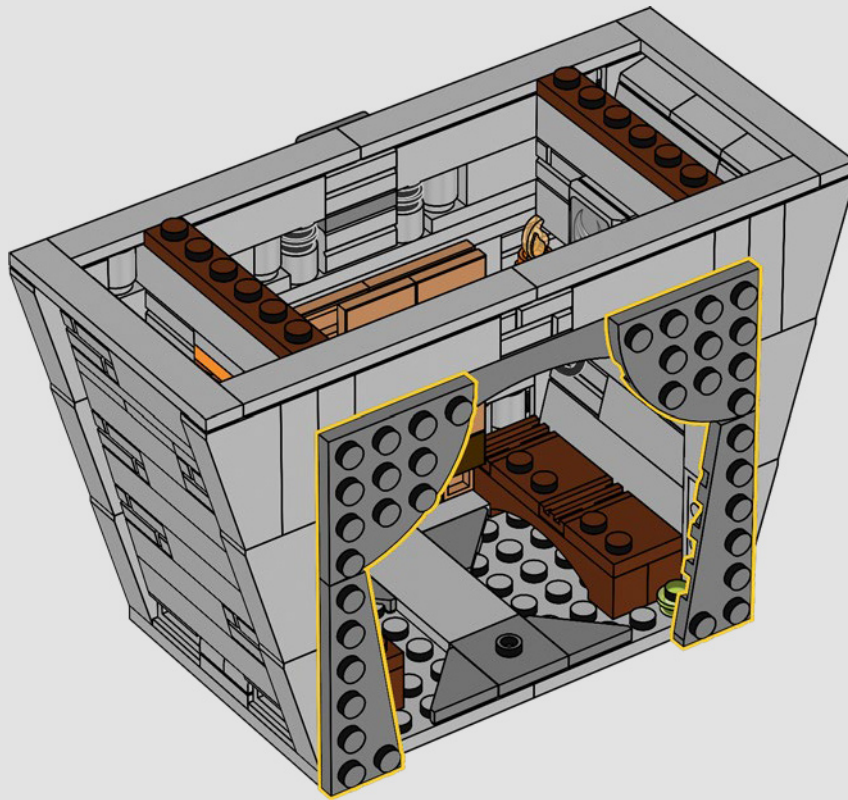



2x

74

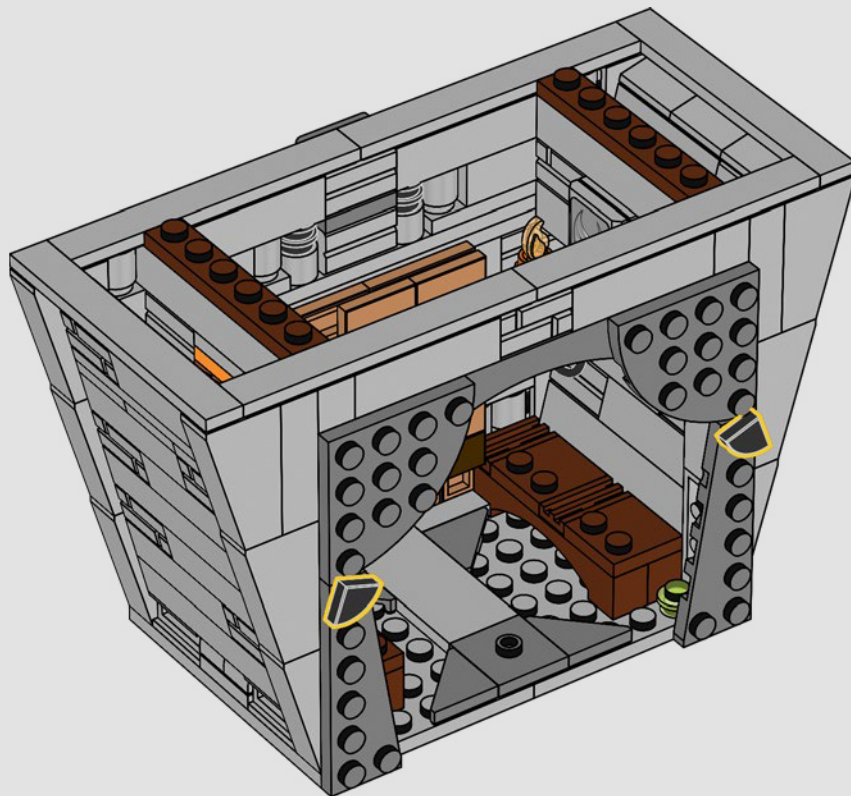

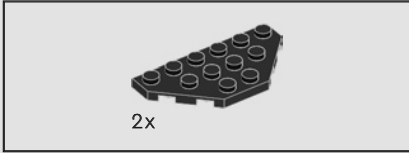
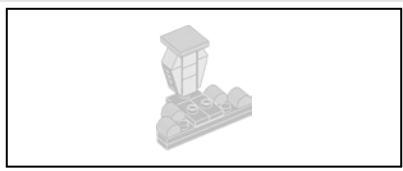

75

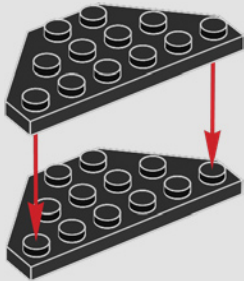

76

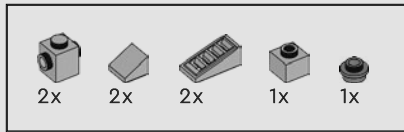
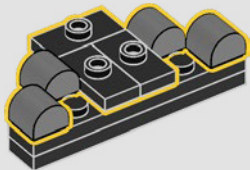

77

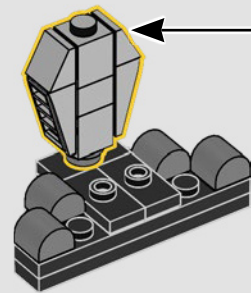
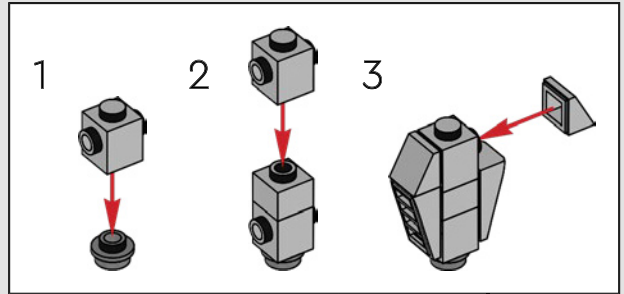

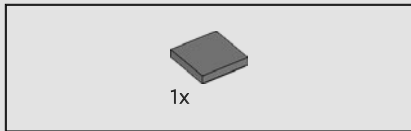

78

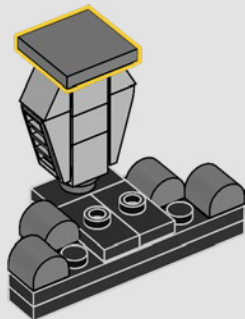

79

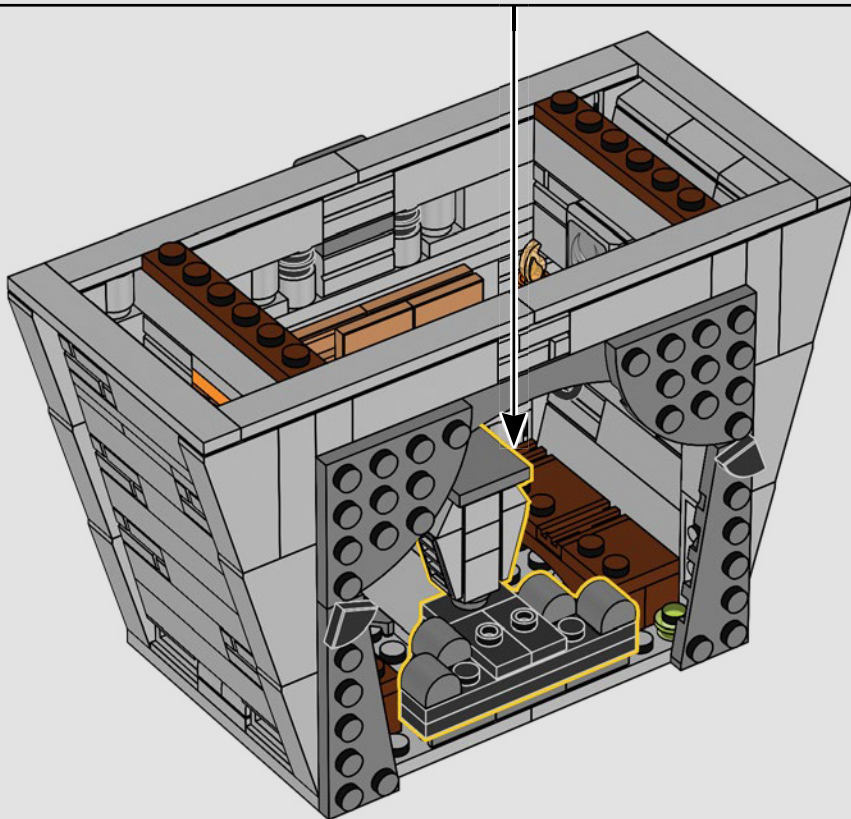

80

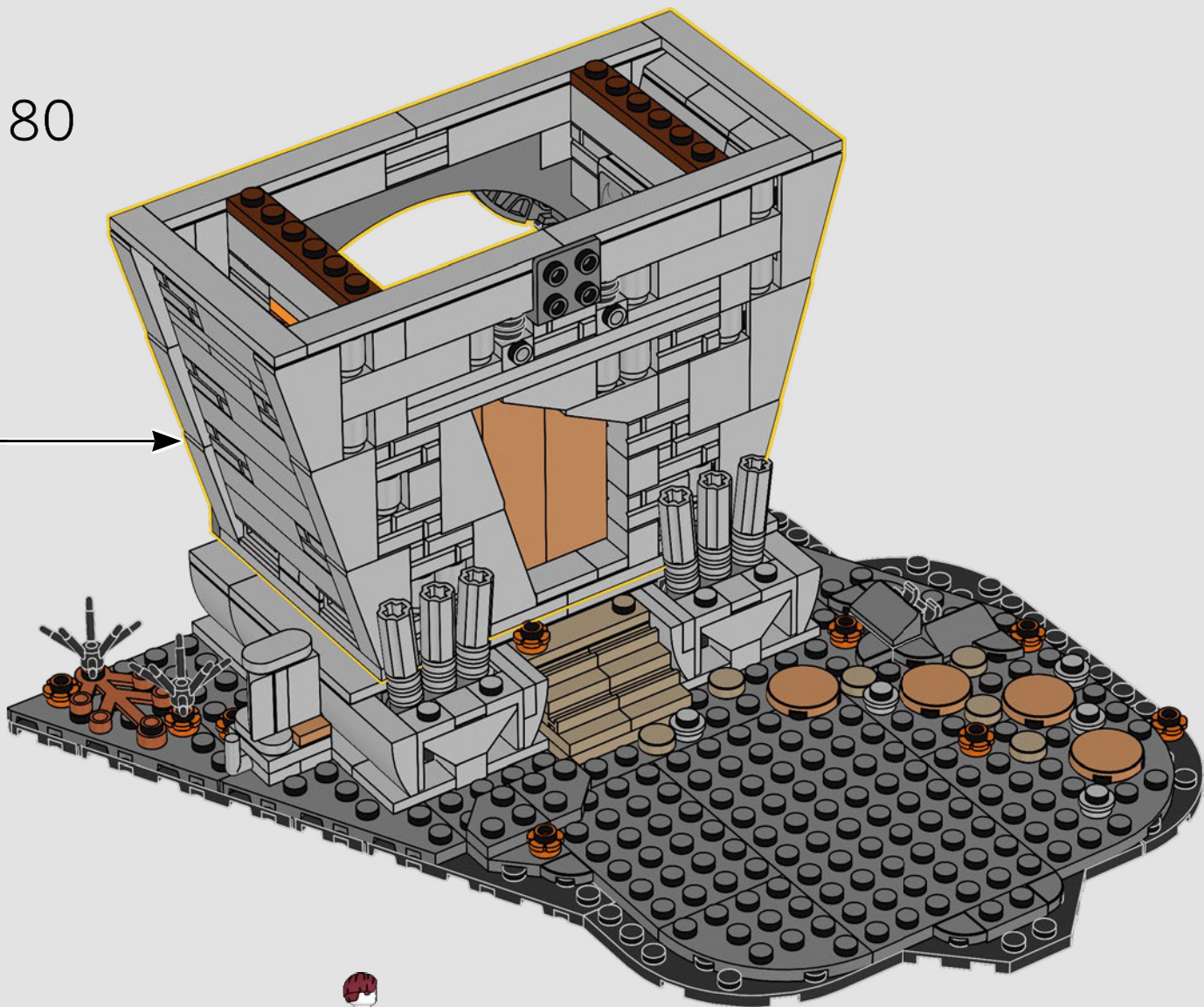

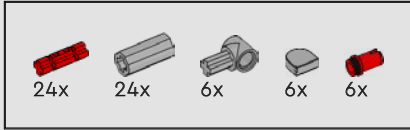
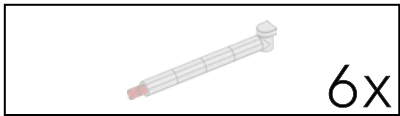

81

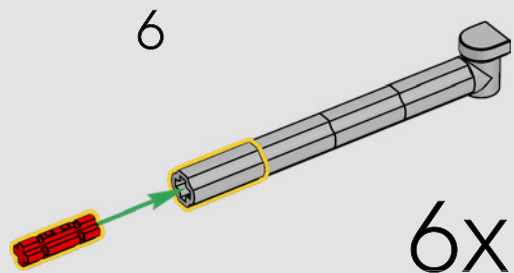
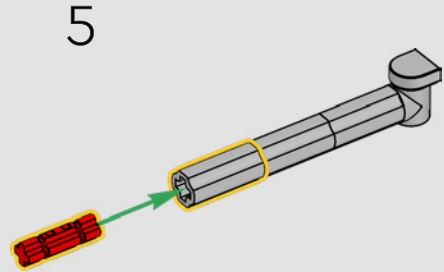
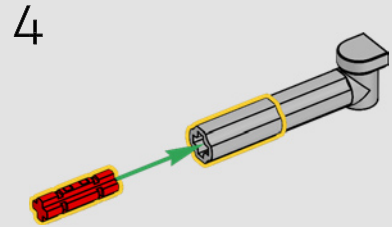
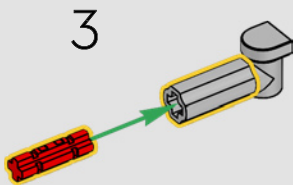
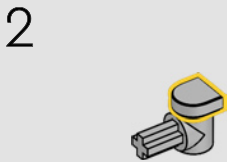
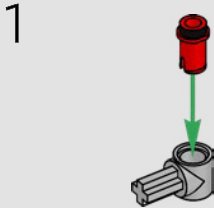



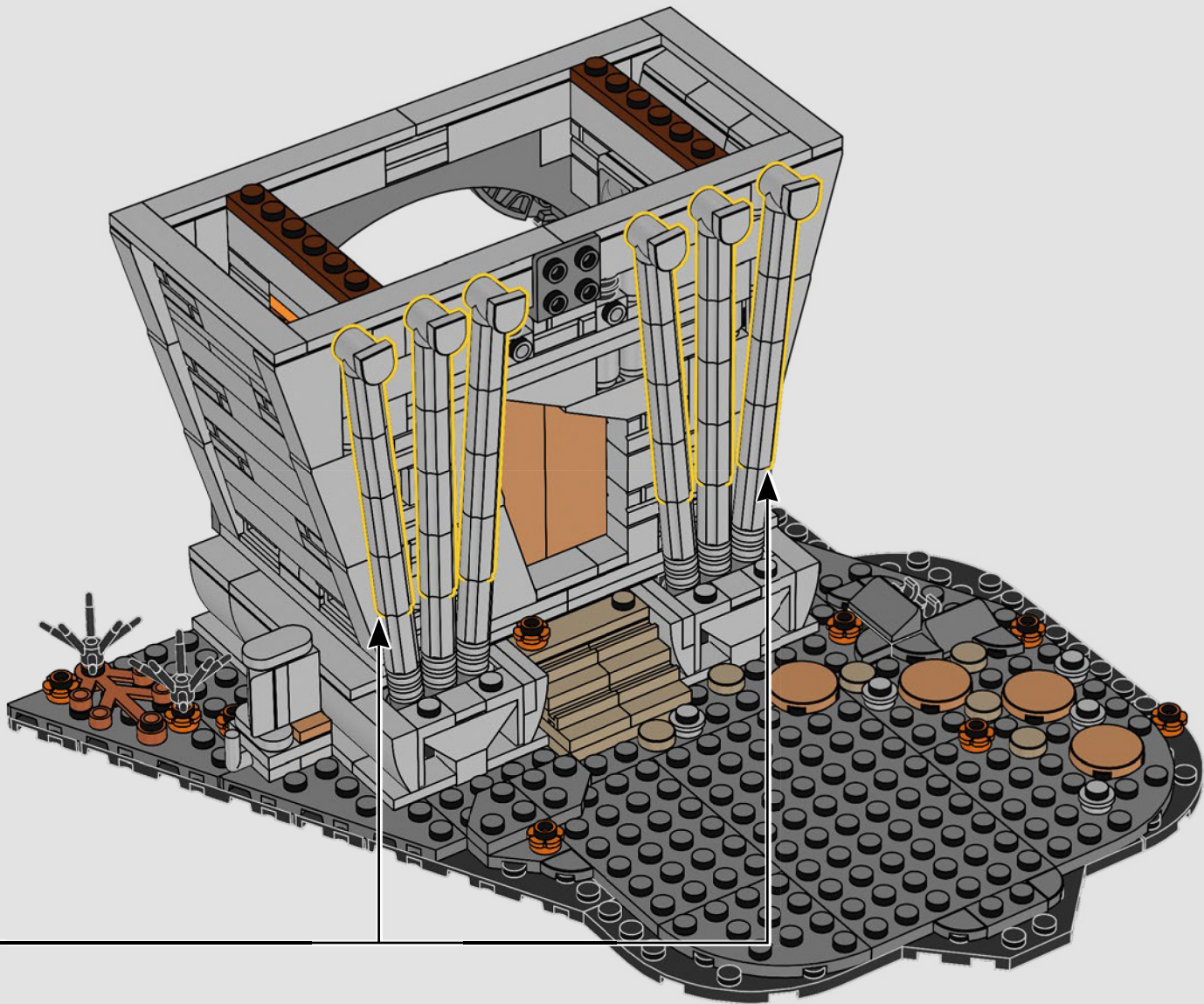

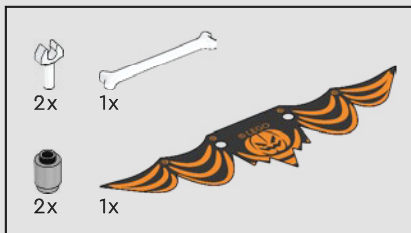

82

1

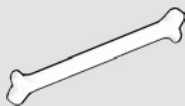

2

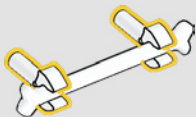

3



4

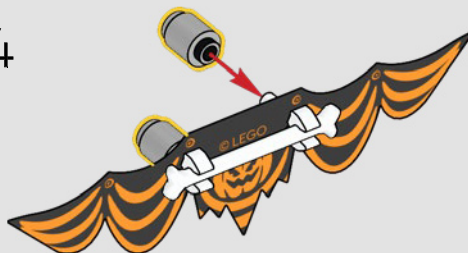

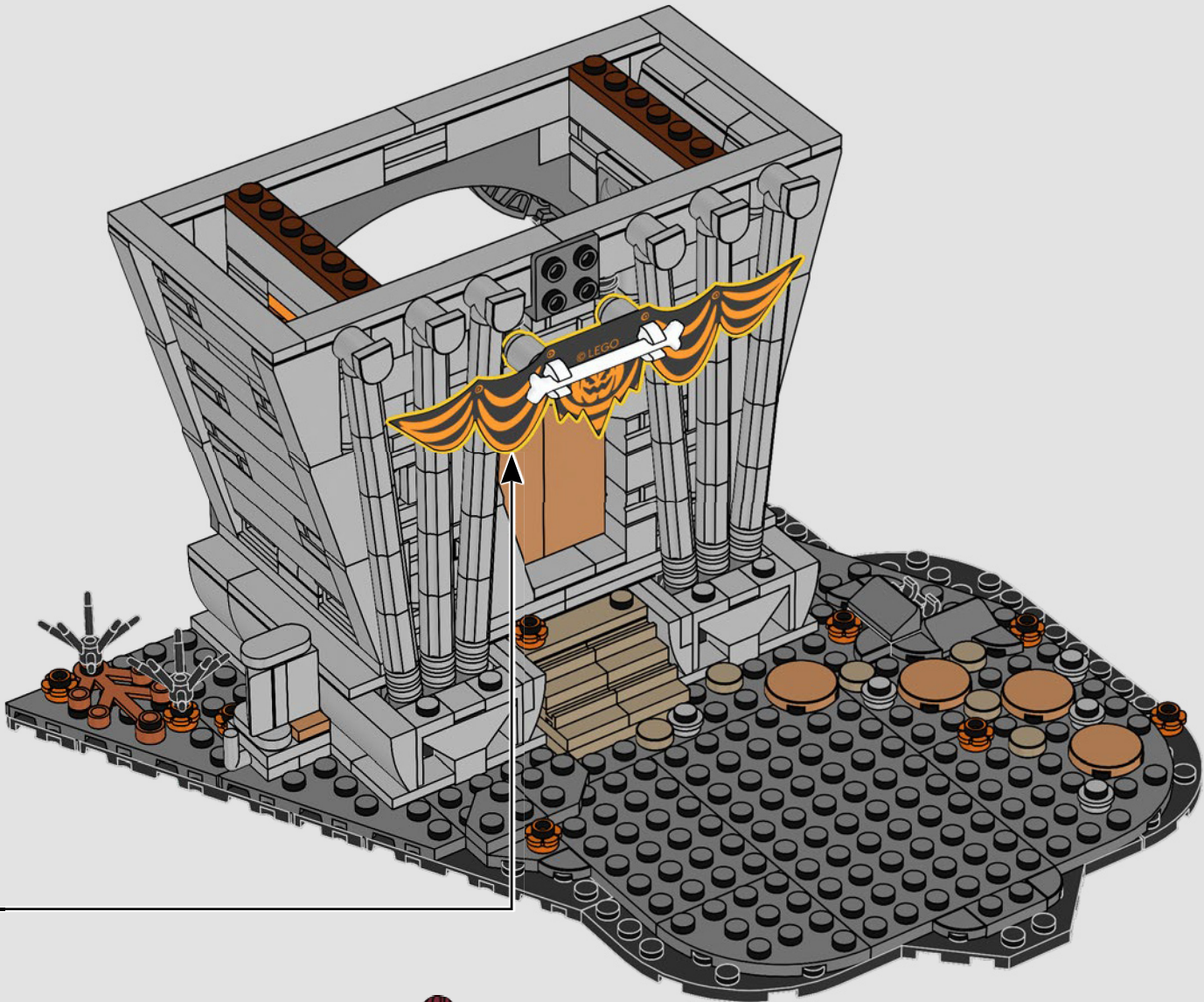

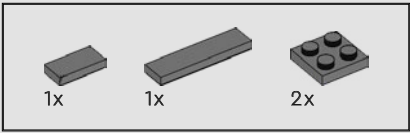

83

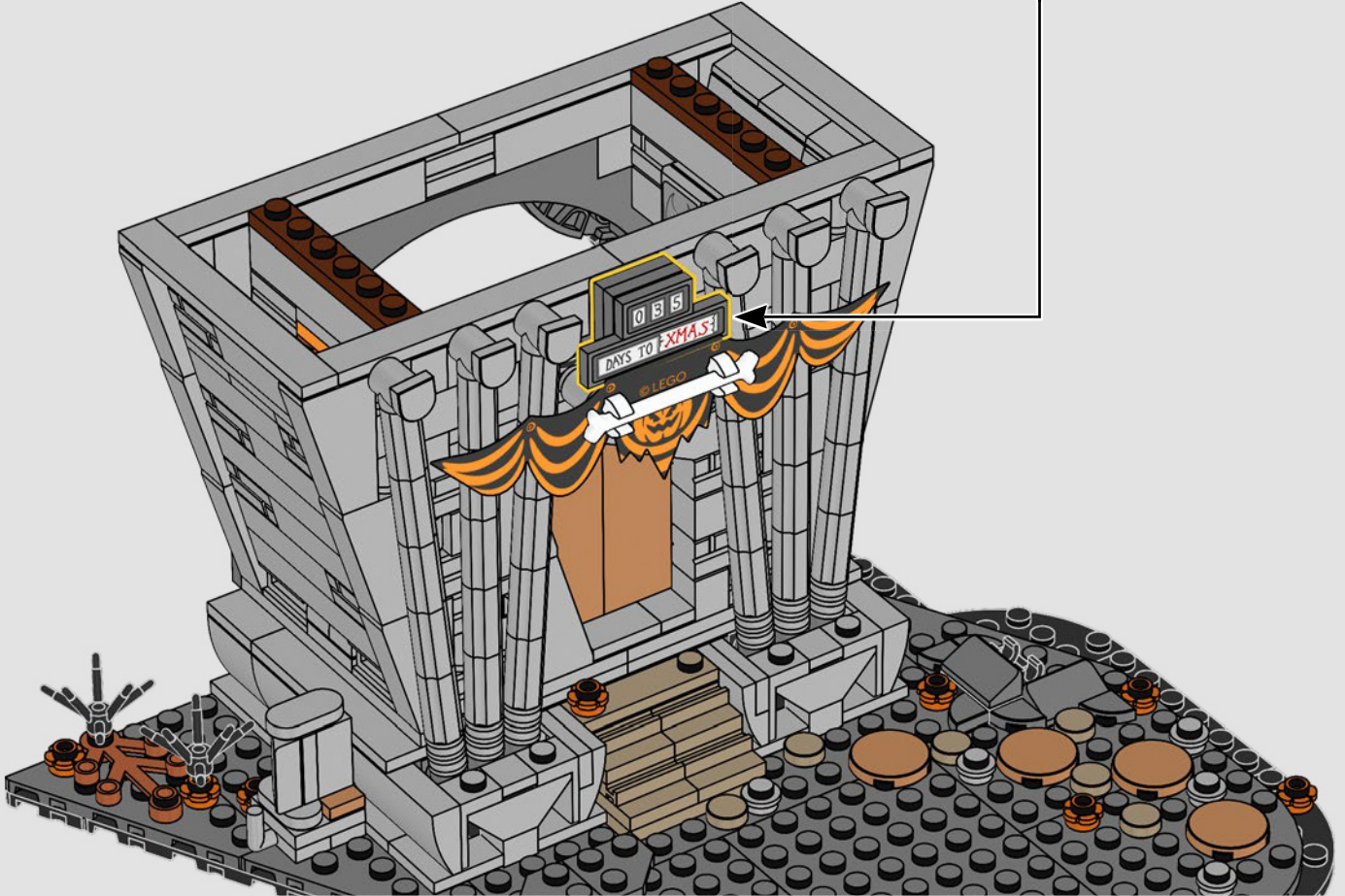
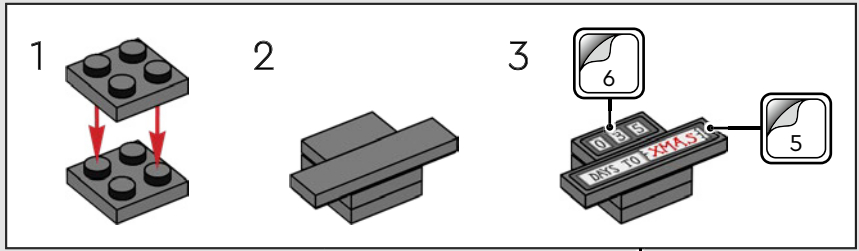

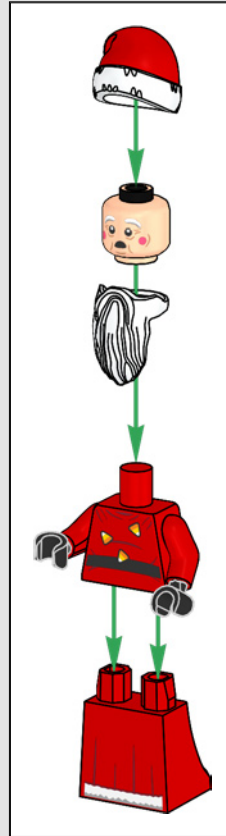

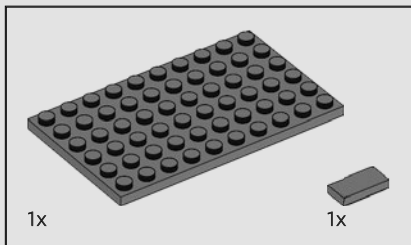
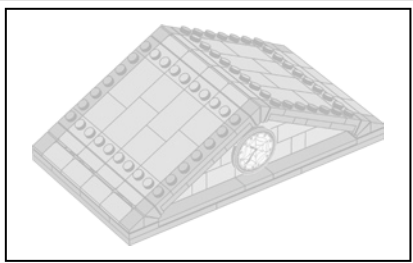

84

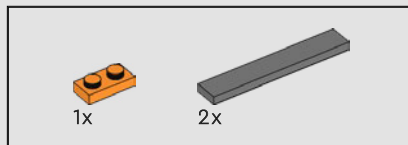
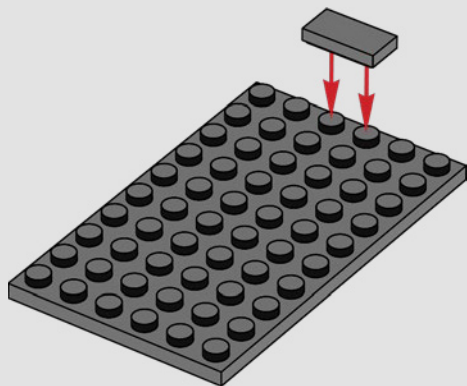

85

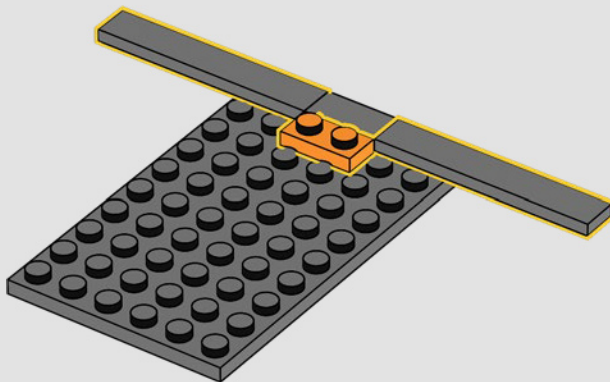

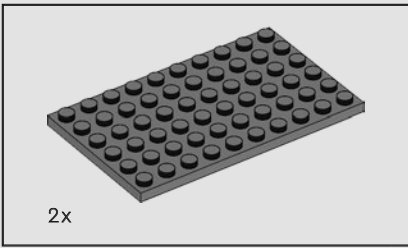

86

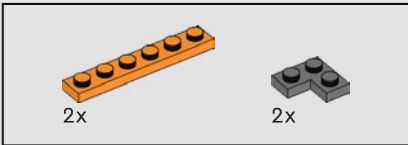
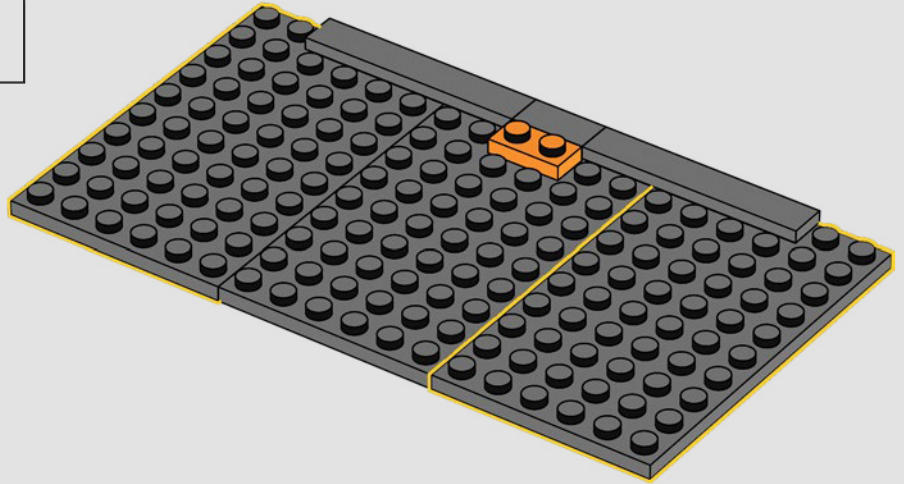

87

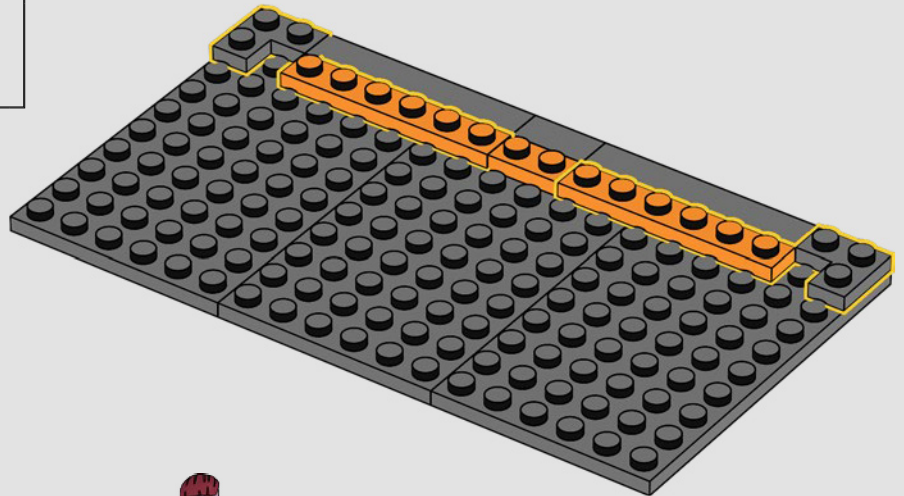

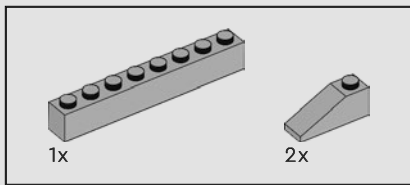

88

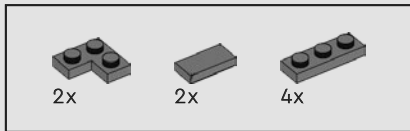
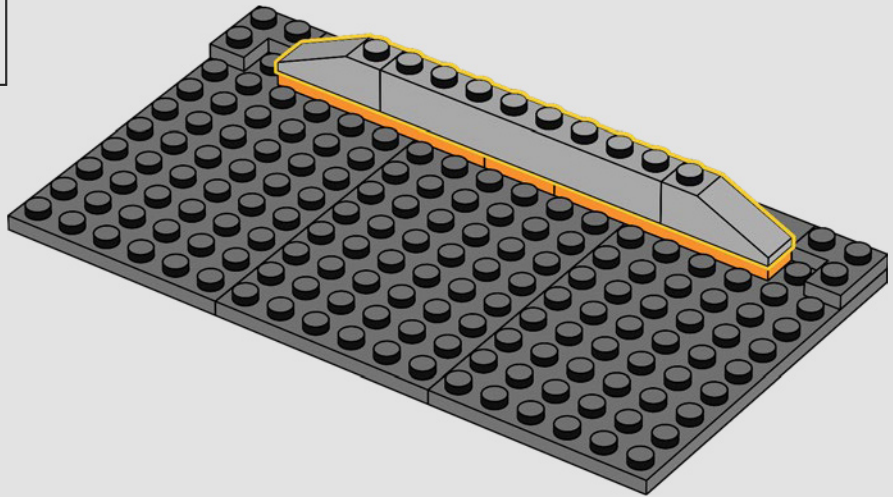

89

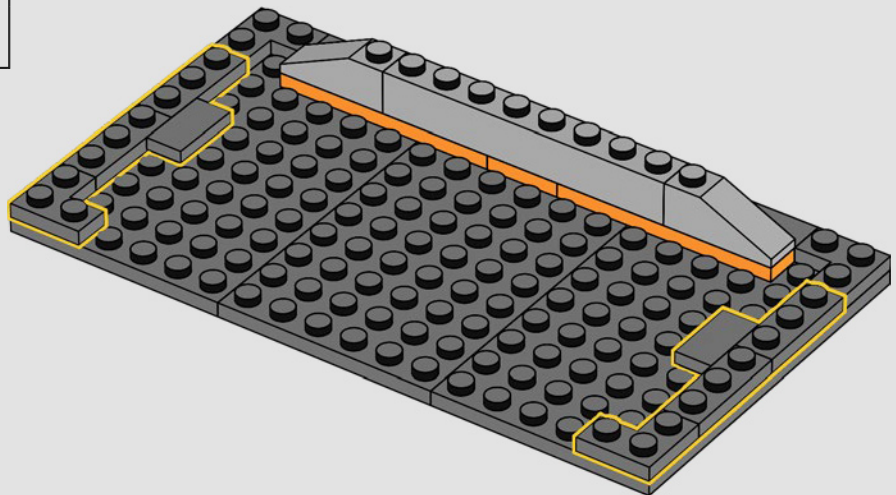



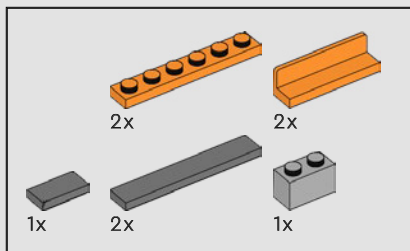

90

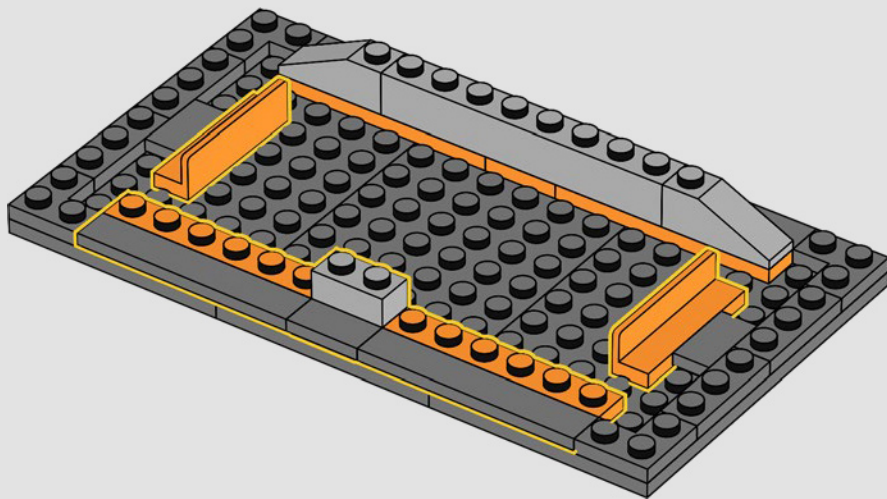

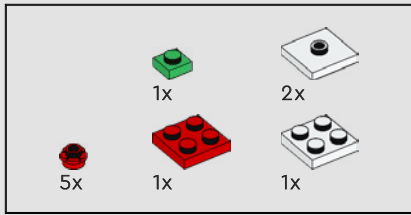

91

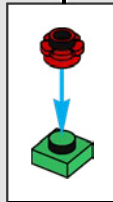
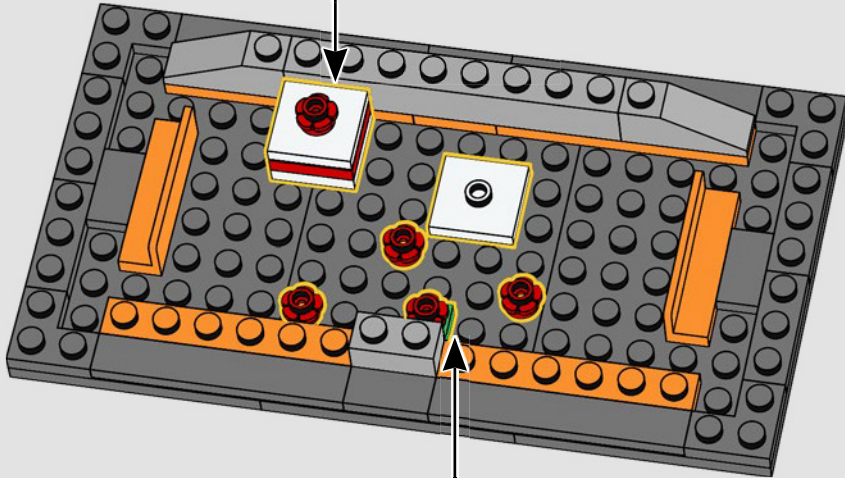
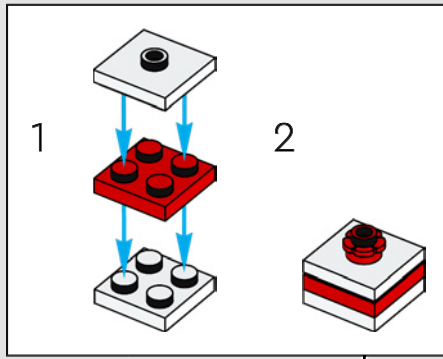

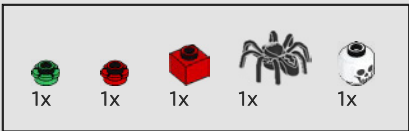

92

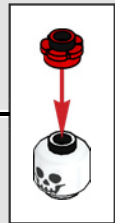
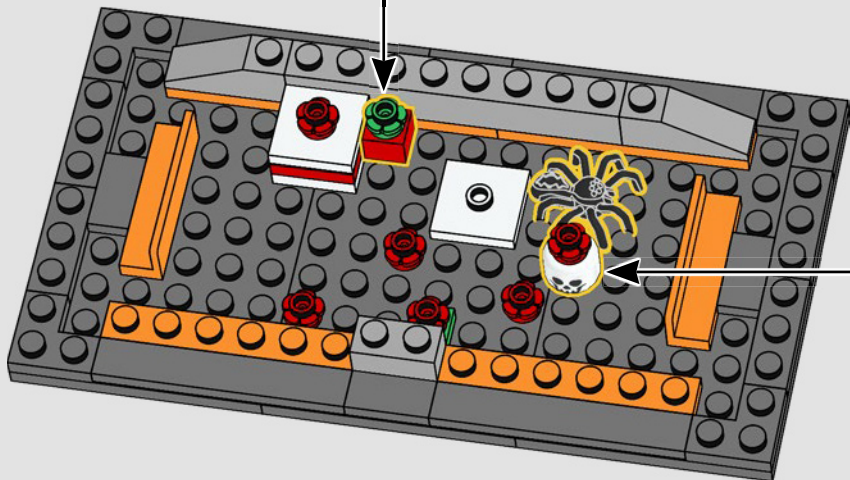
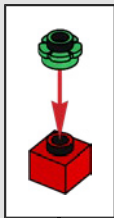

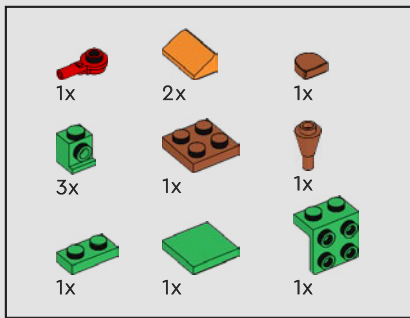

93

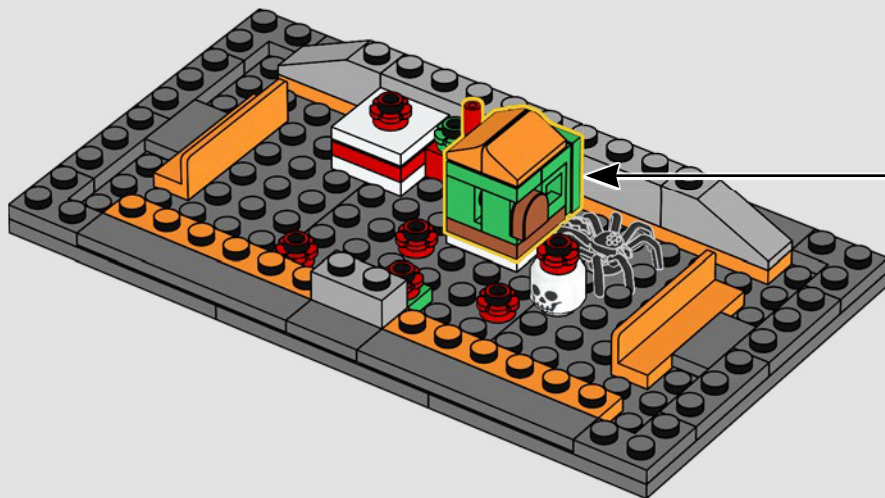
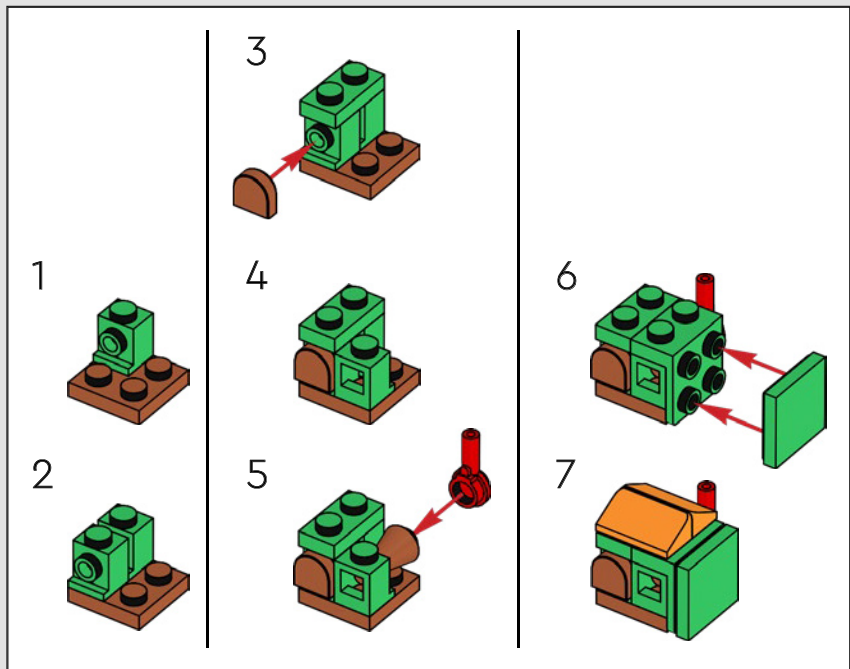



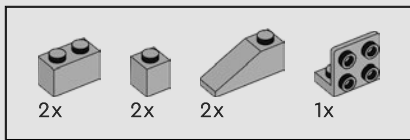

95

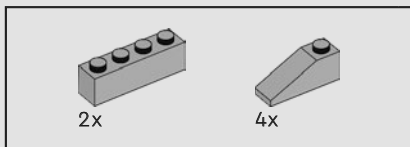
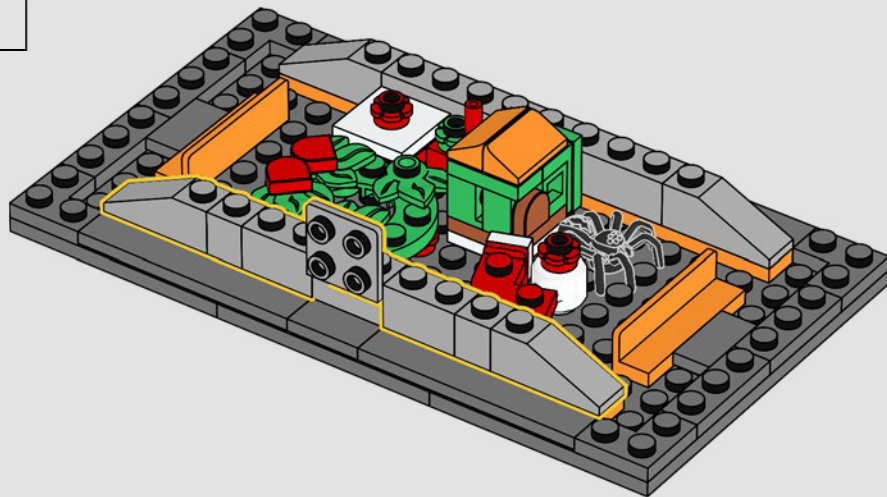

96

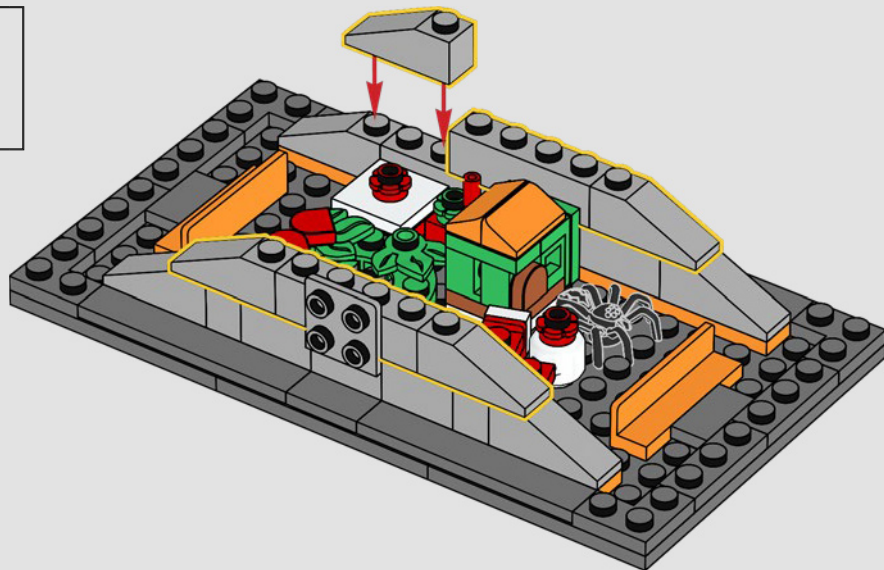

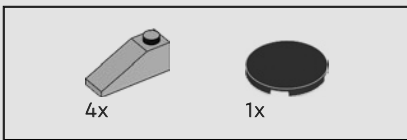

97

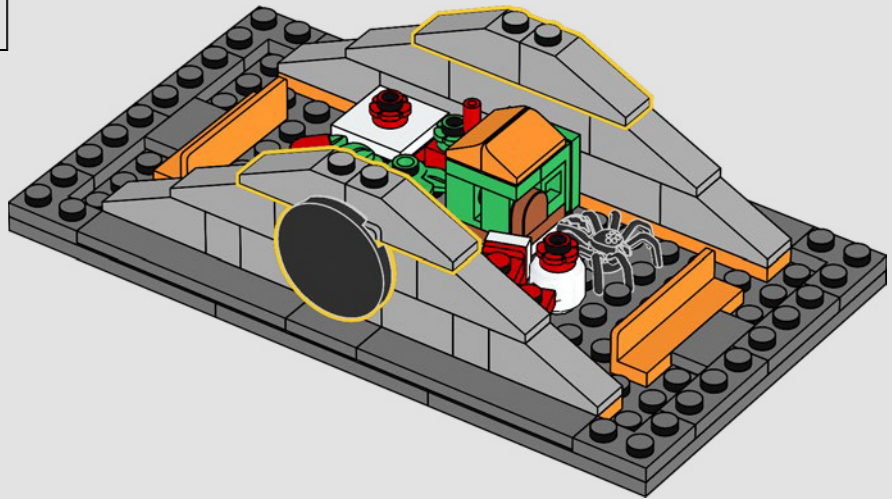

98

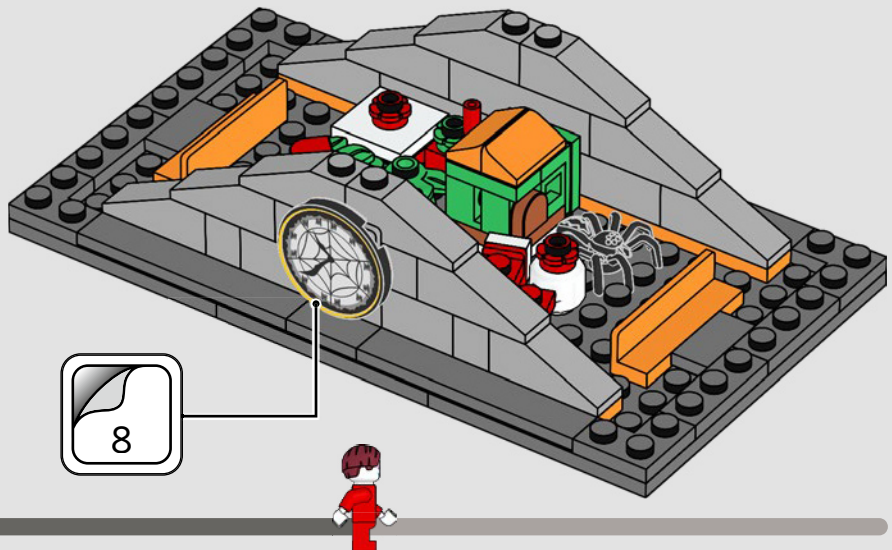

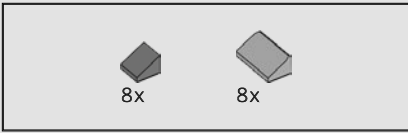

99

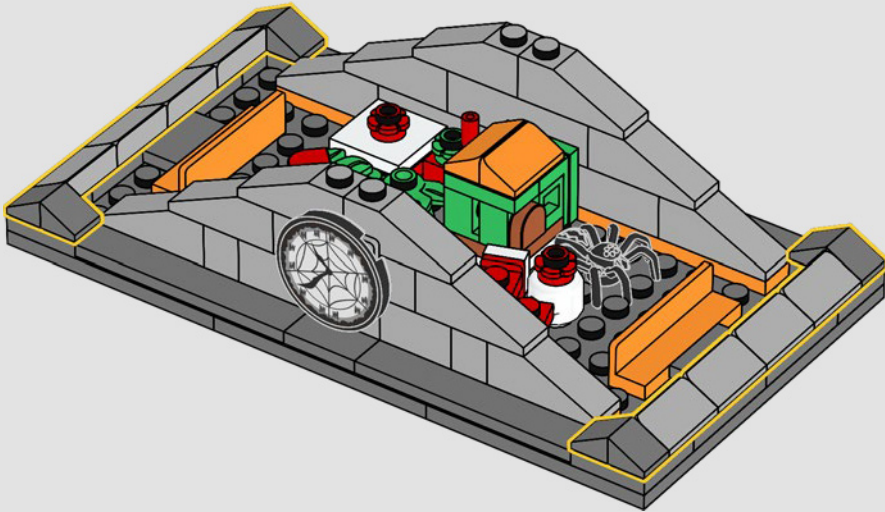



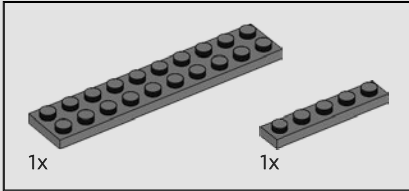
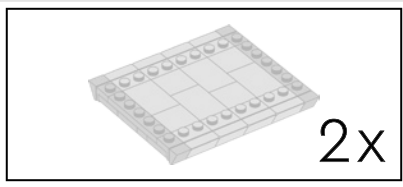

100

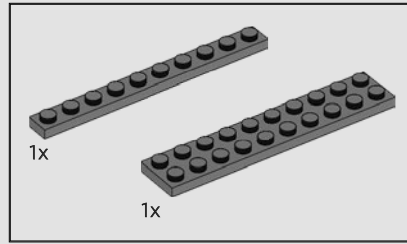
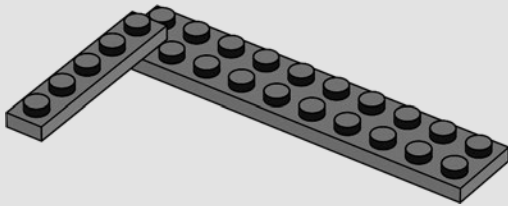

101

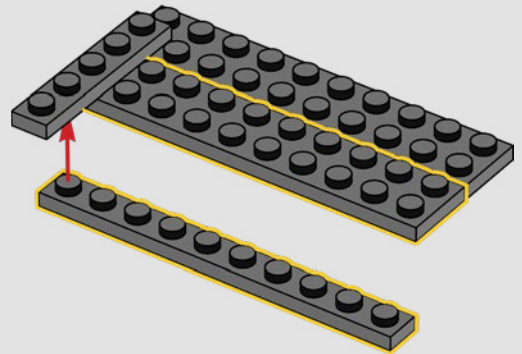

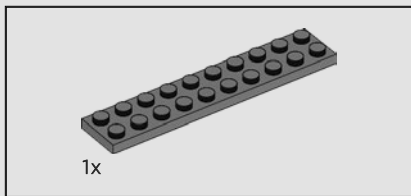

102

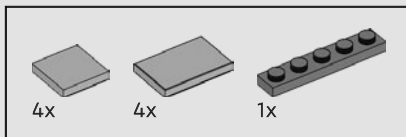
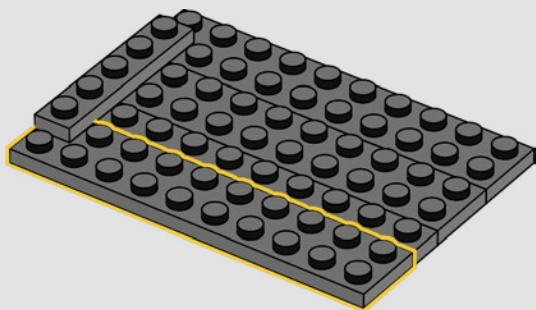

103

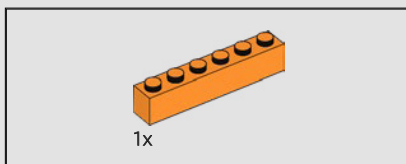
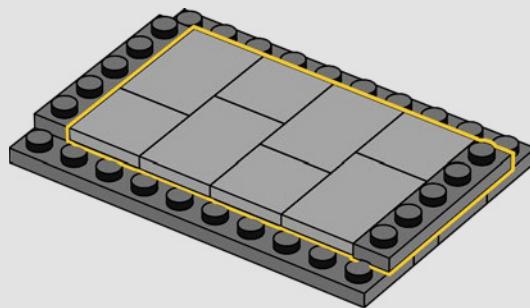

104

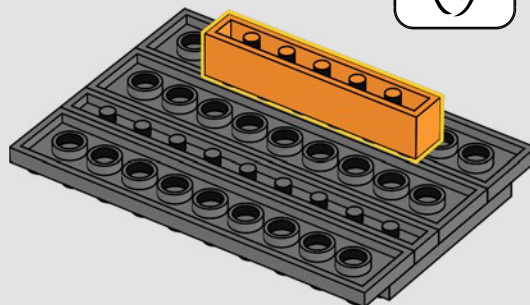

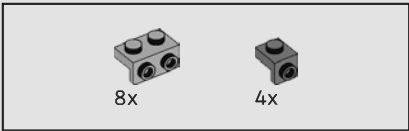

105

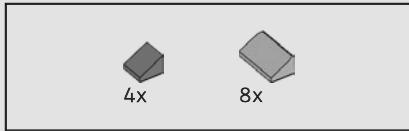
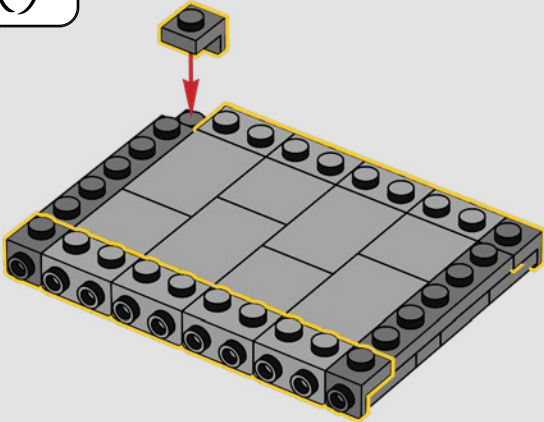

106

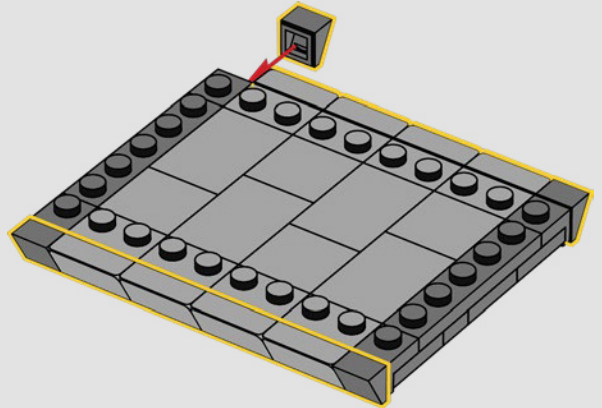

2x



107

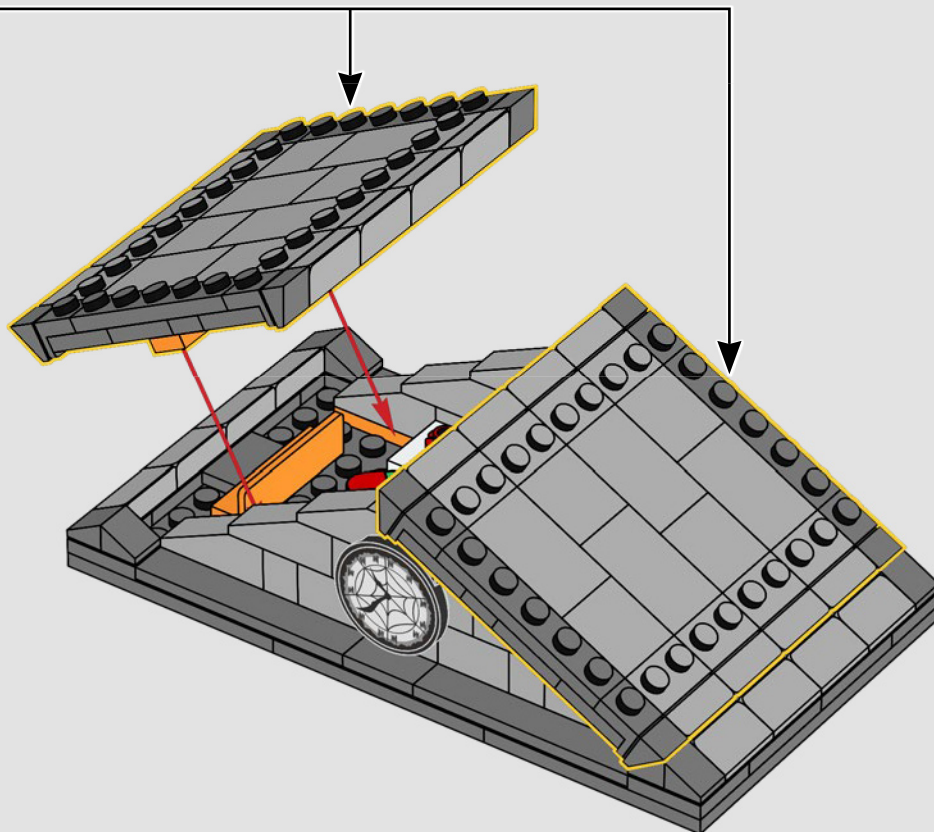

108

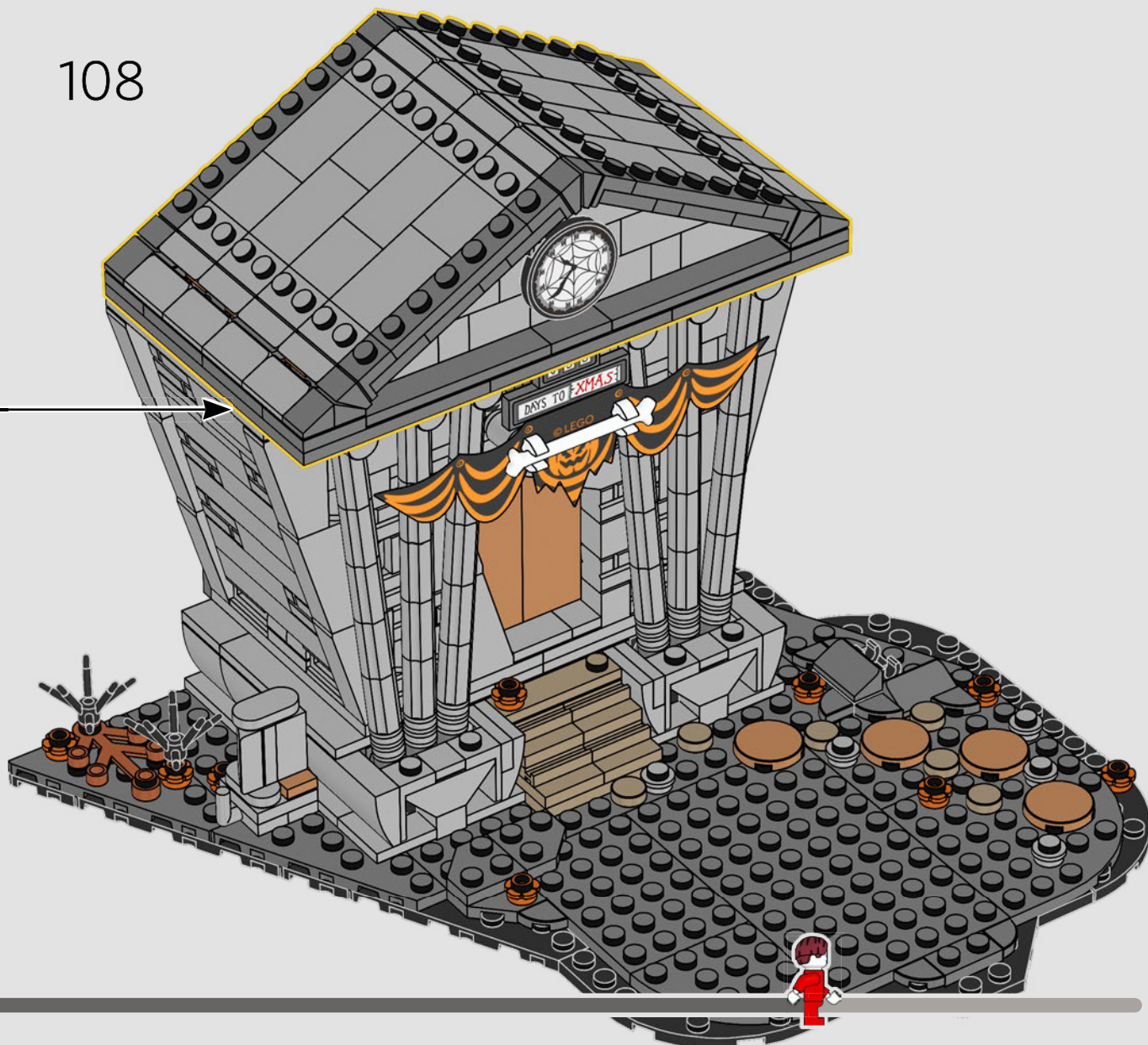



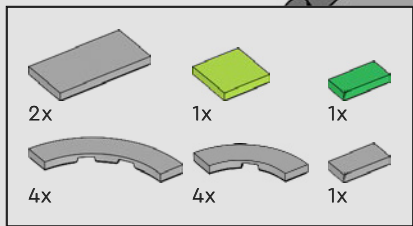

109

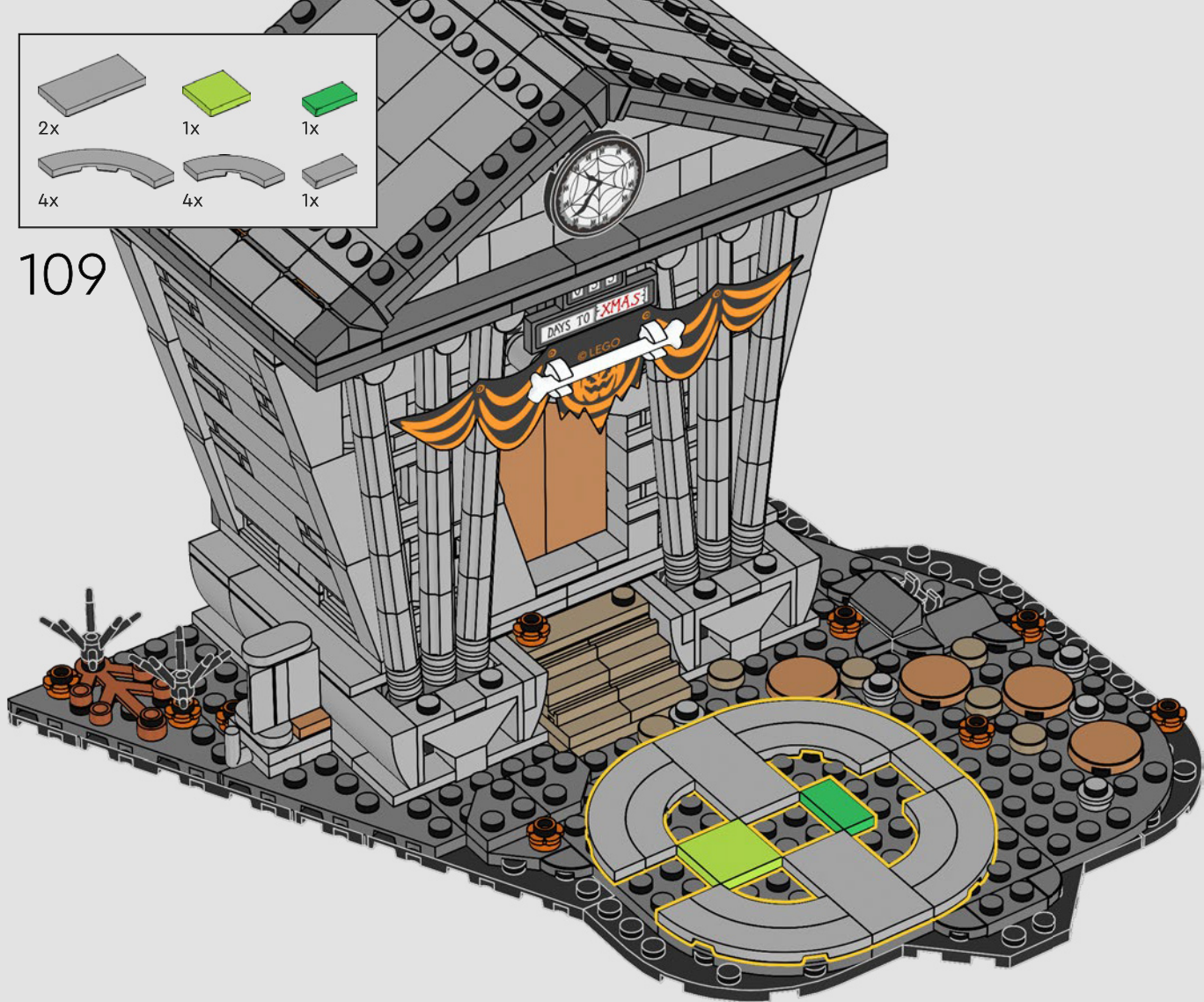

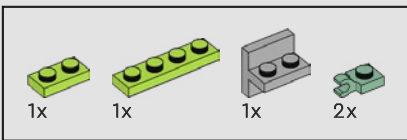

110

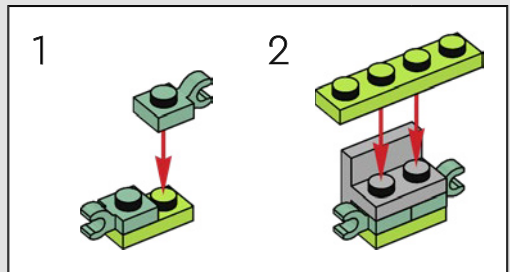
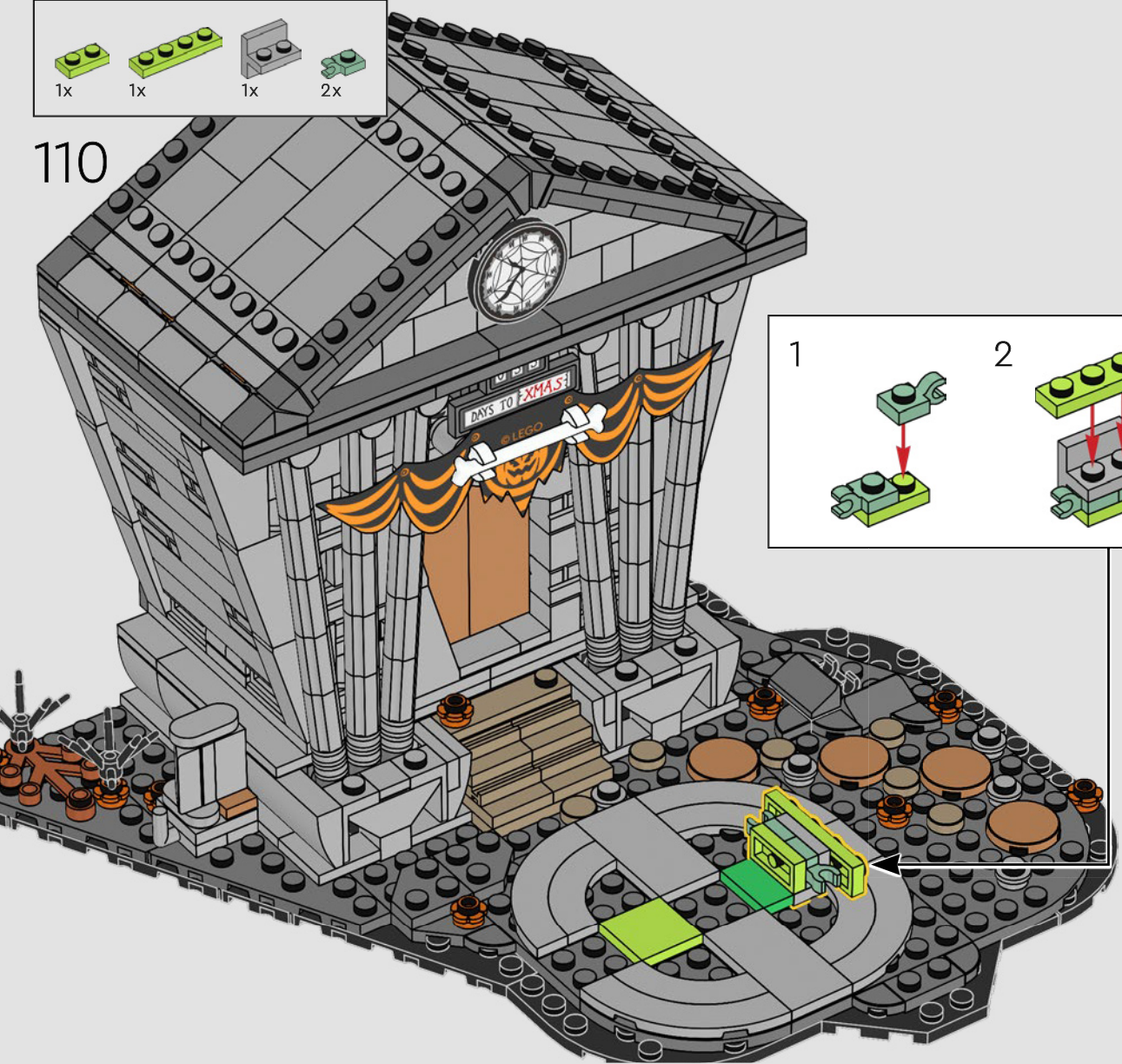



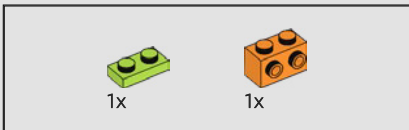
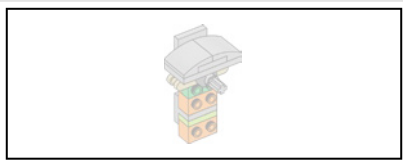

111

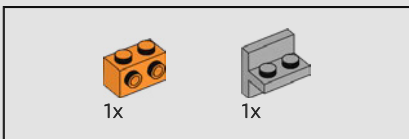
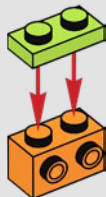

112

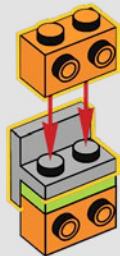

113

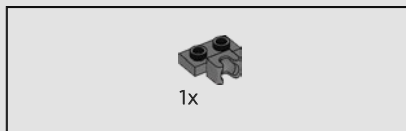
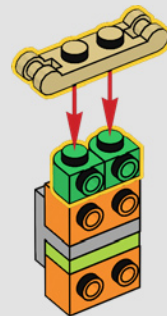

114

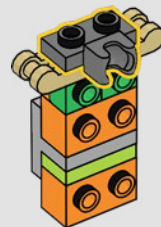

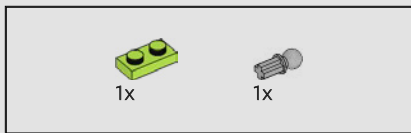

115

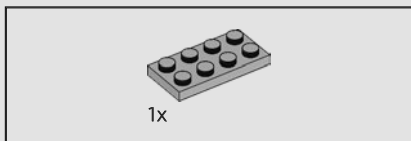
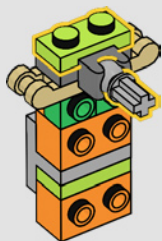

116

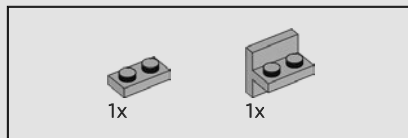
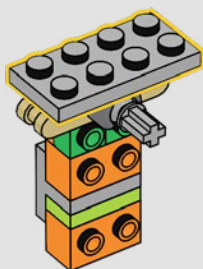

117

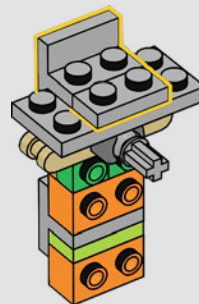

118

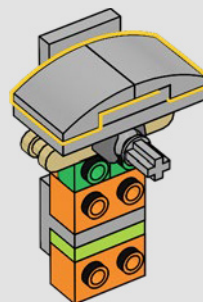

119

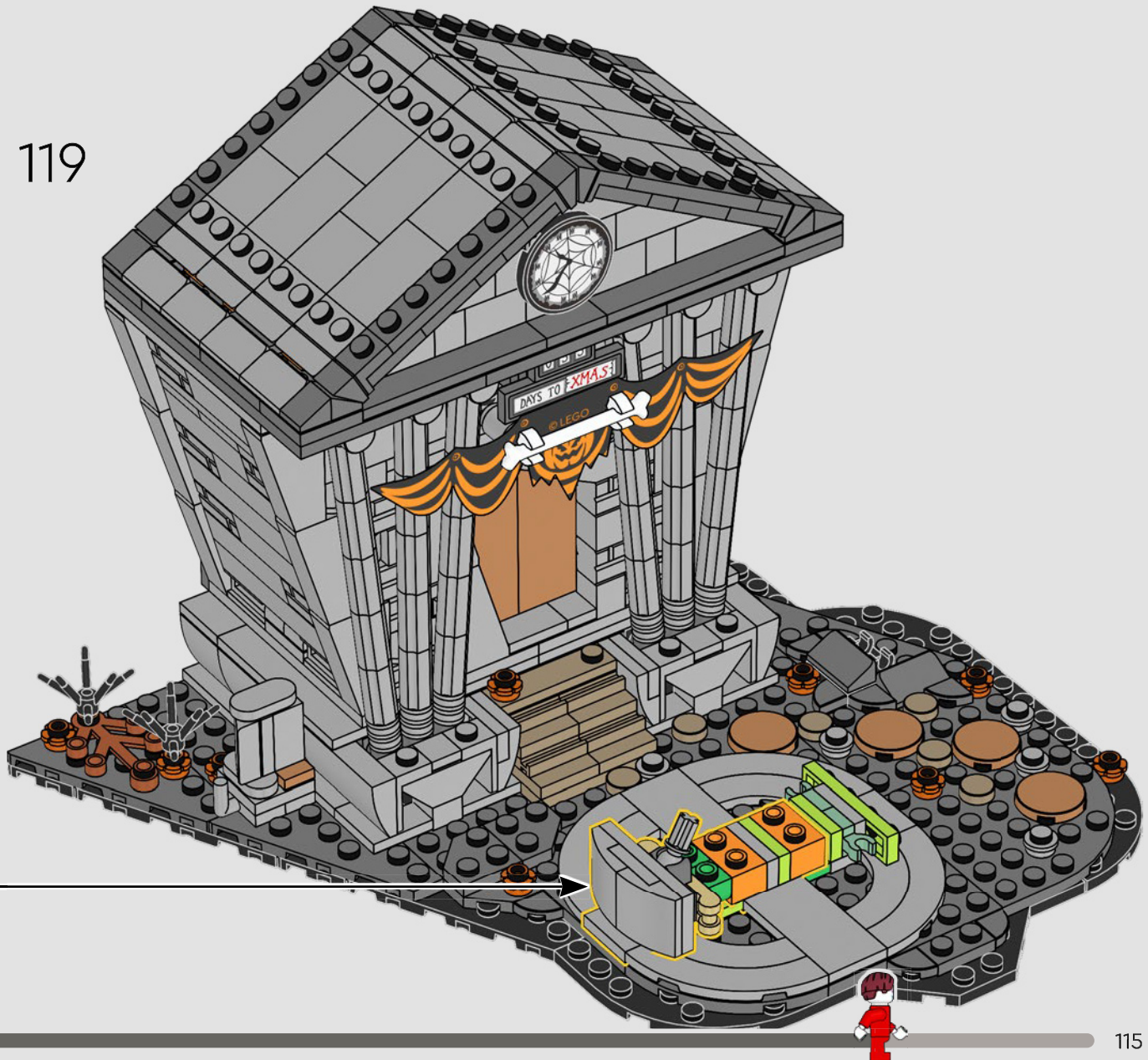



120

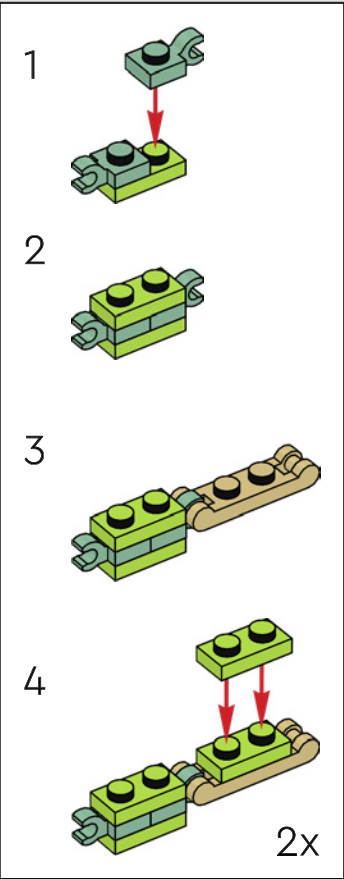





1x  24x  1x 

121

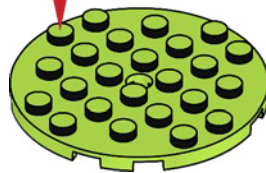
1 

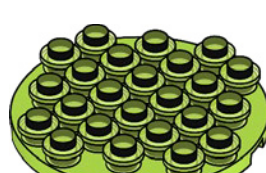
2 

3 

3 





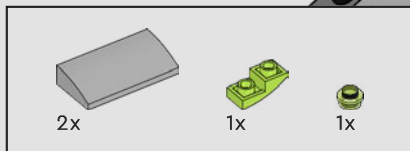

123

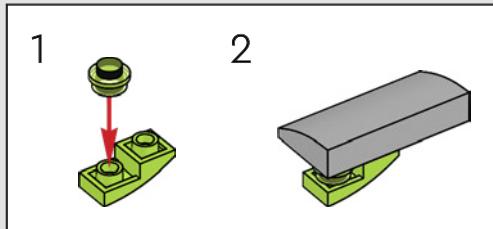
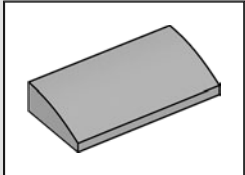
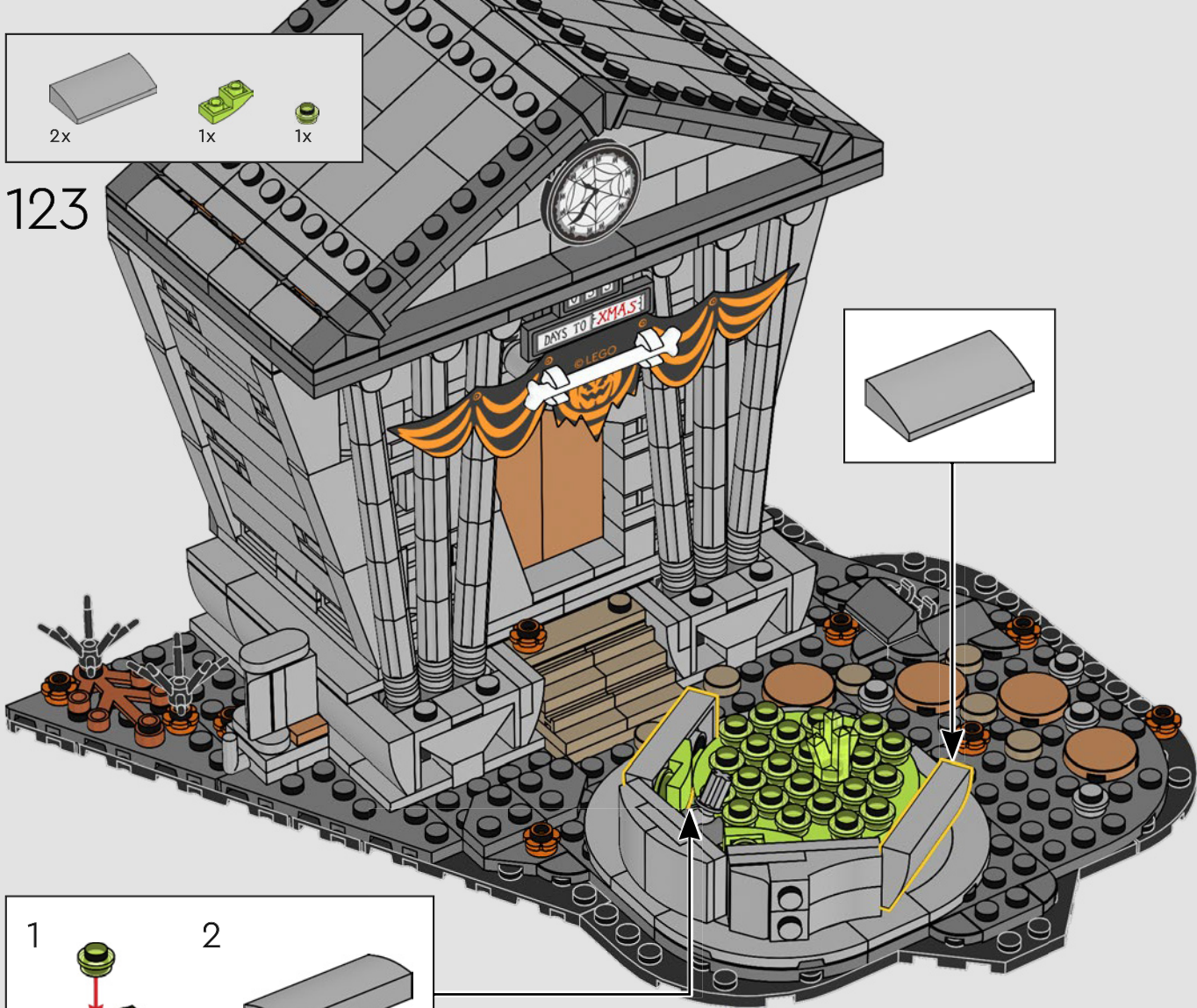

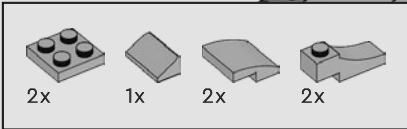

124

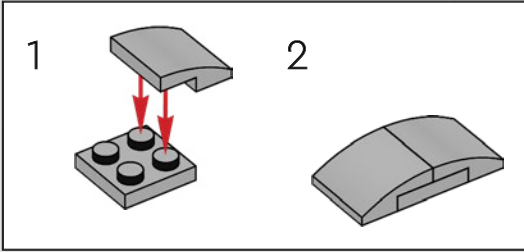
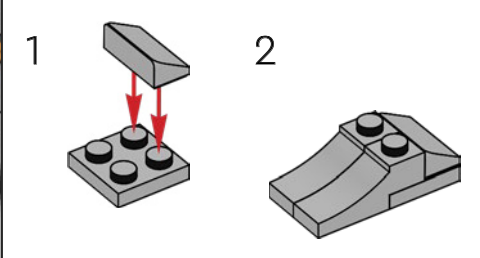
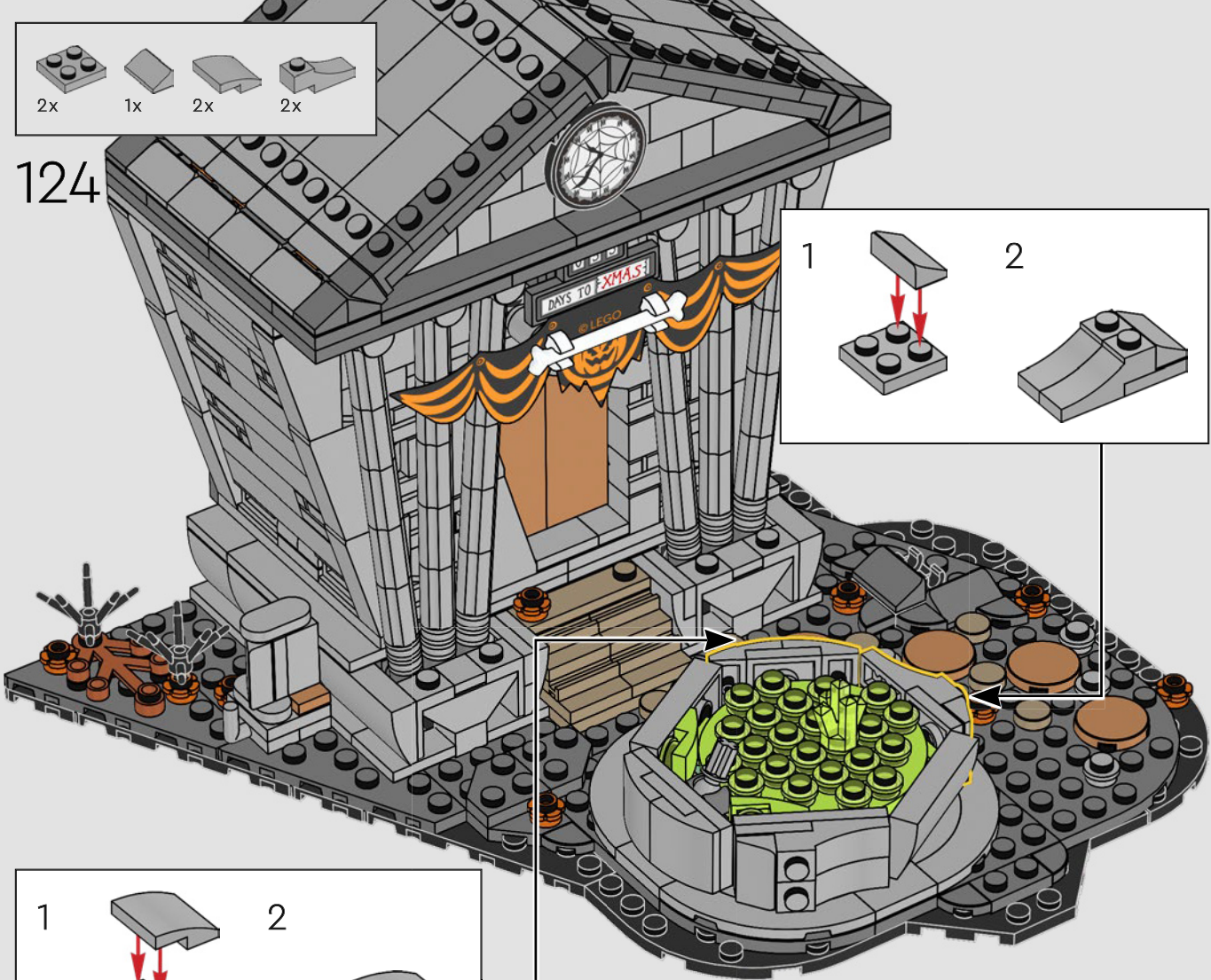



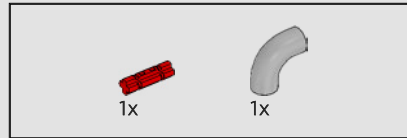
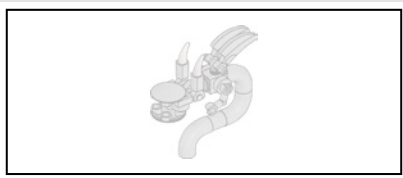

127

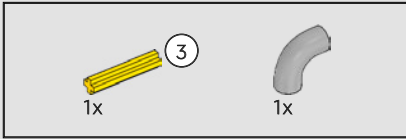

125

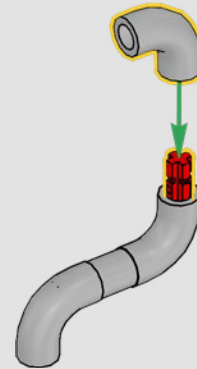
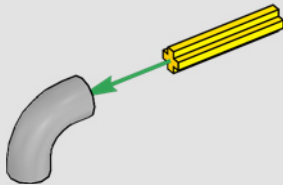

128



126

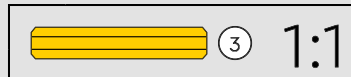
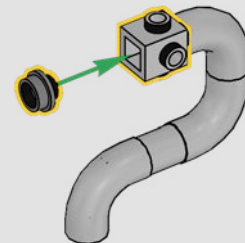
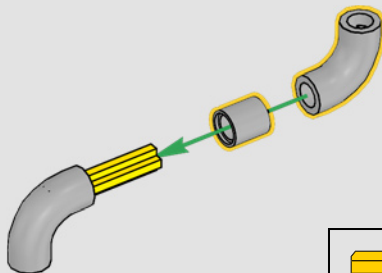

2x

129

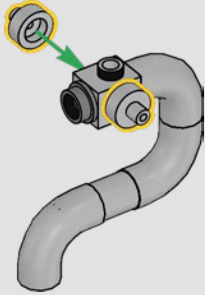

2x

130

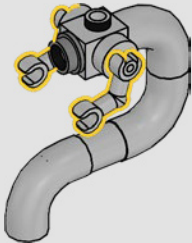

1x

131



2x 1x

132

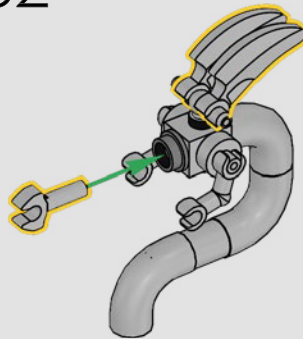

1x 2x 2x

133

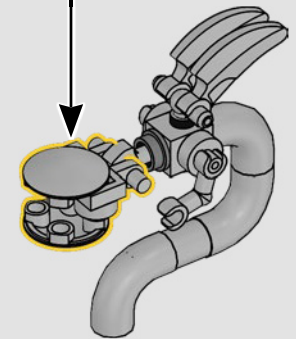
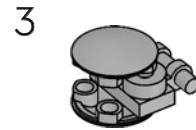
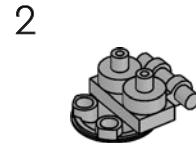
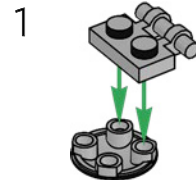

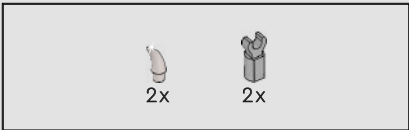

134

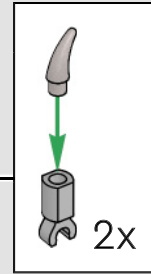
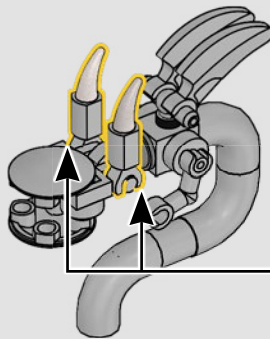

135

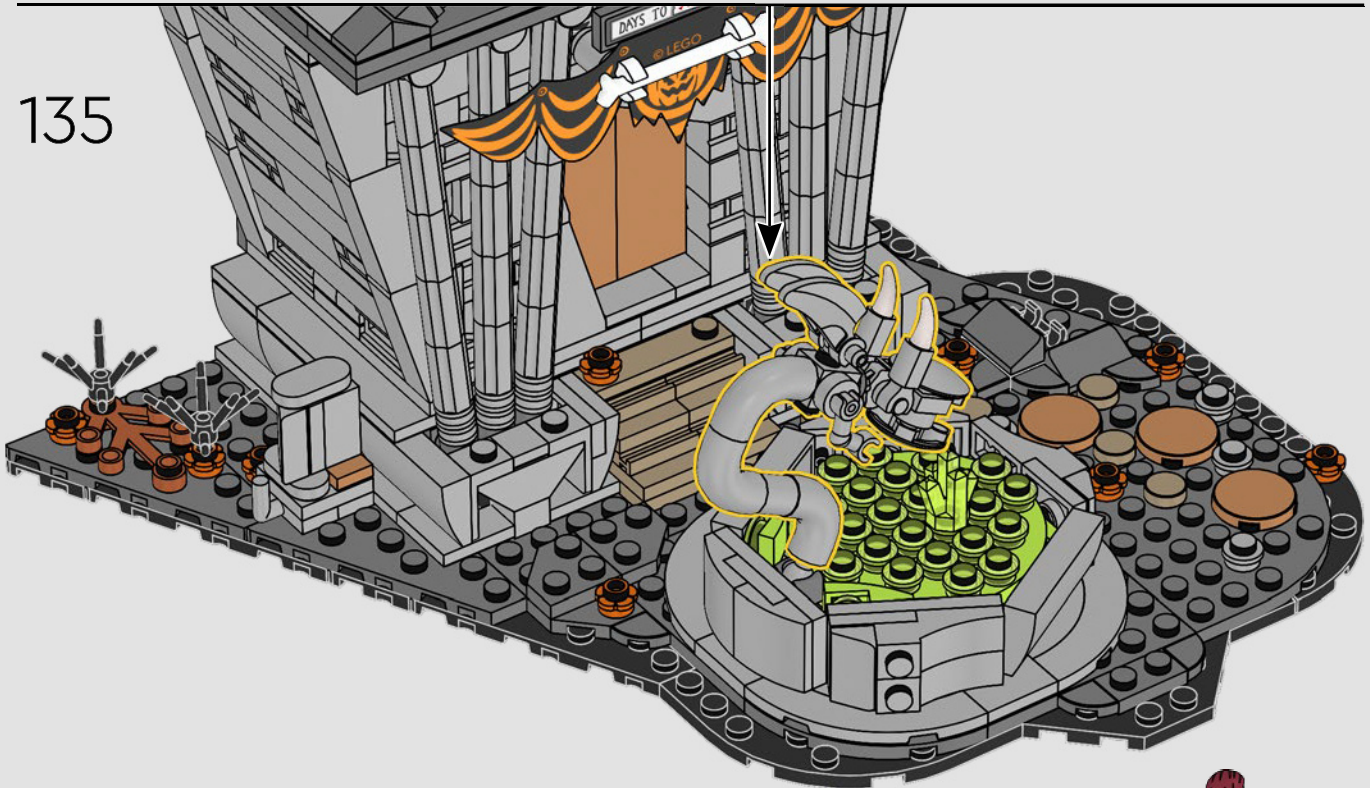

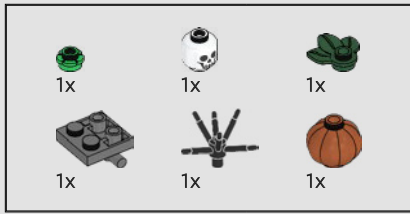

136

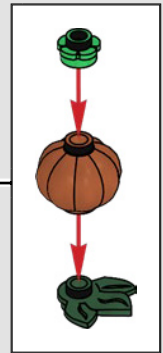
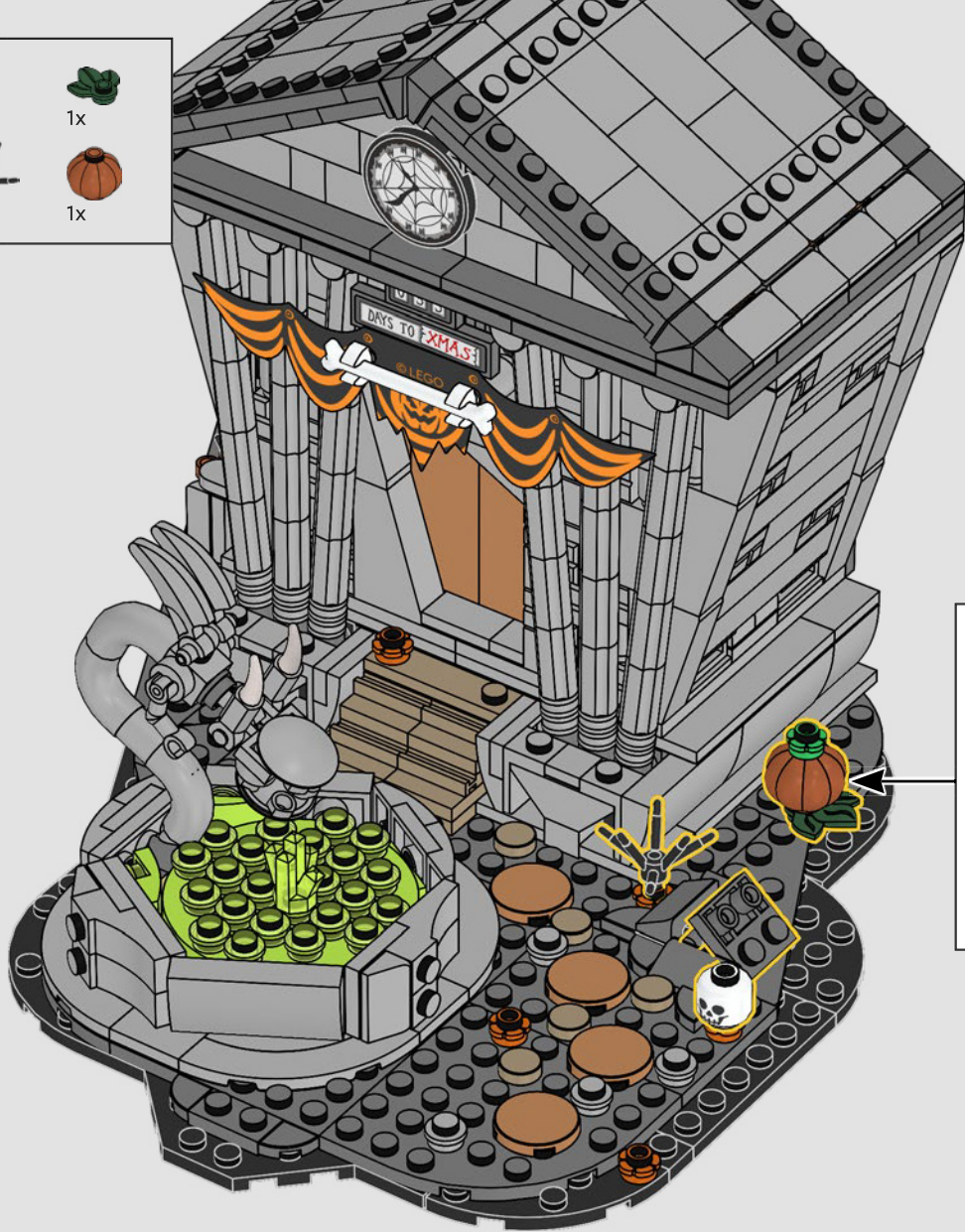

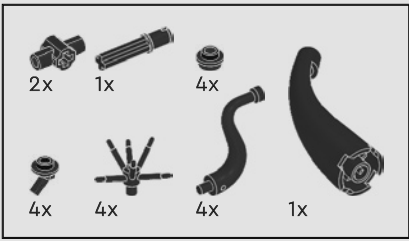

137

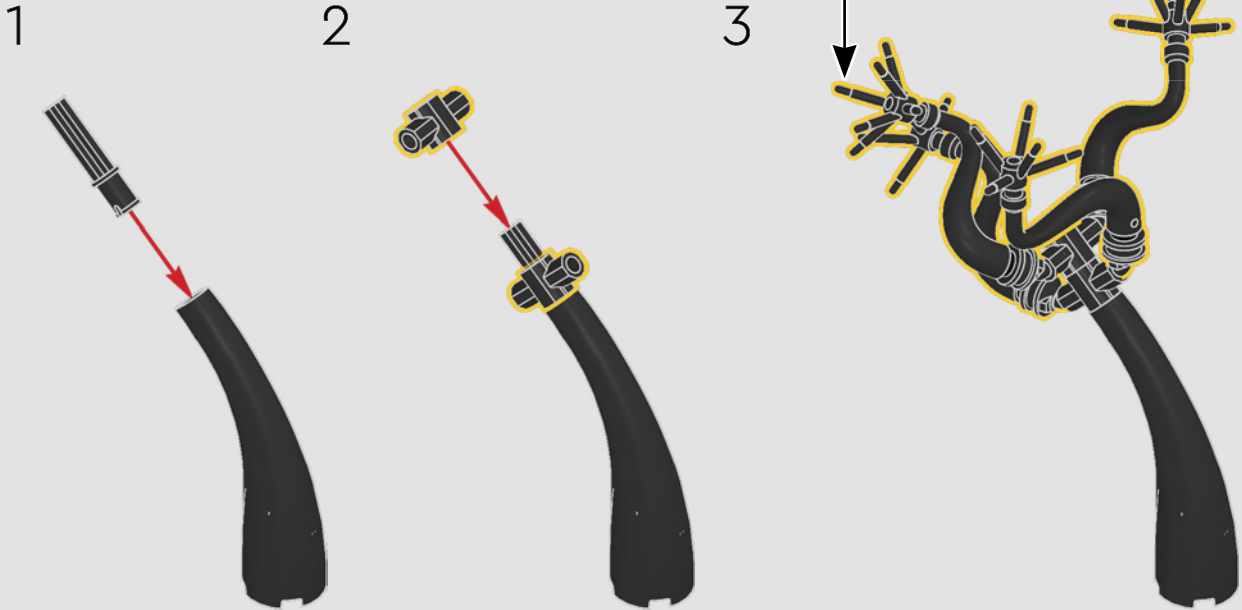
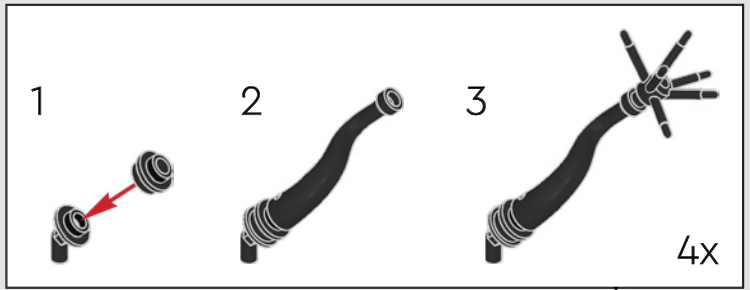



13x

138

13x

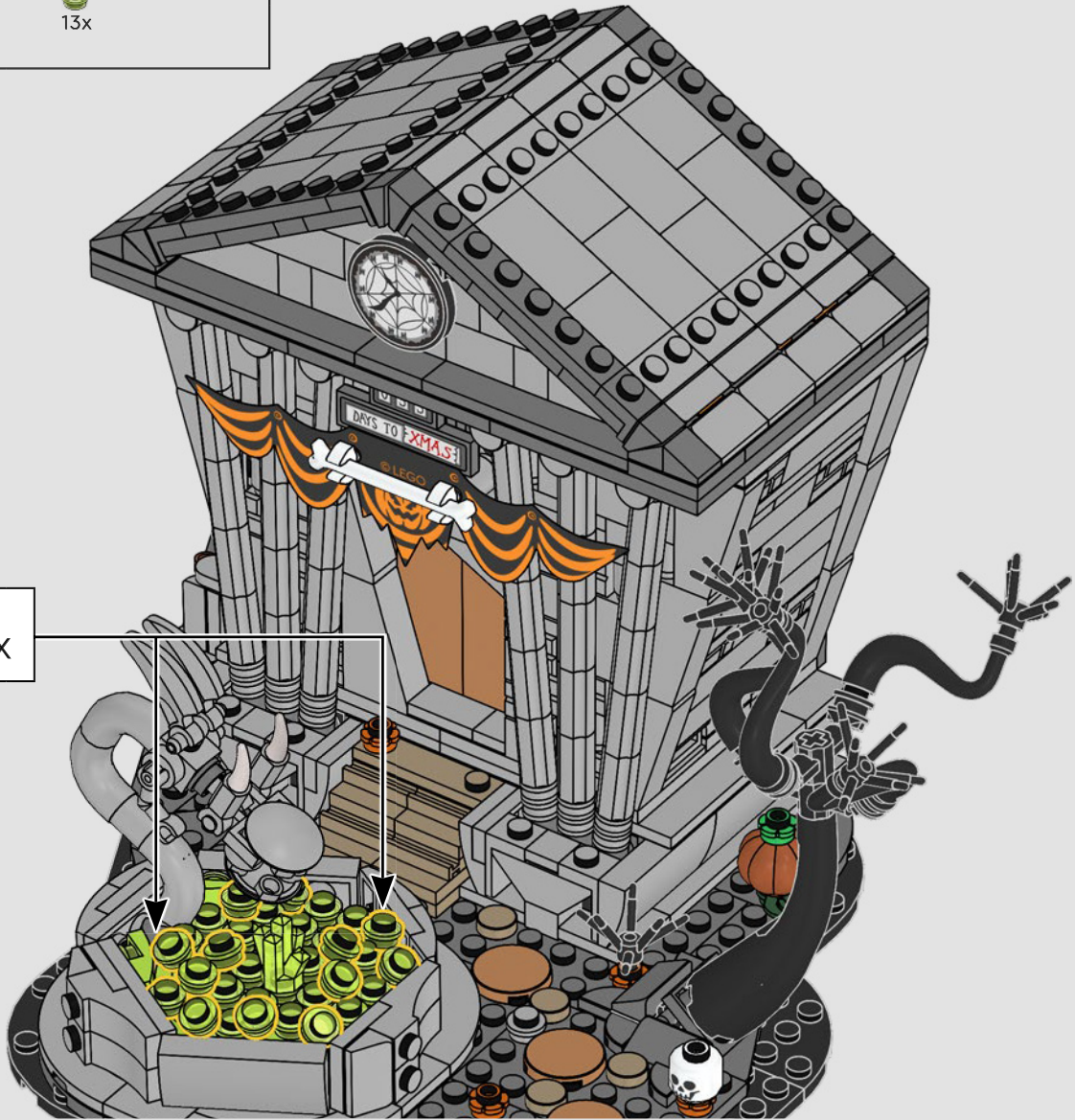



LEGO and the LEGO logo are trademarks of the/sont des marques de commerce du/  
son marcas registradas de LEGO Group. ©2024 The LEGO Group. 6535578  
©Disney