





Disney • PIXAR

WALL • E

21303



 Booklet available in English on
 Livret disponible en français sur
 Folleto disponible en español en www.LEGO.com/ideas

 LEGO.com/ideas

WALL•E

WALL•E (short for Waste Allocation Load Lifter Earth-class), is the last robot left on Earth. He spends his days tidying up the planet, one pile of garbage at a time. During the 700 years he has existed, WALL•E has developed a personality, and he is also more than a little lonely. Then he meets EVE, a sleek search robot sent to Earth on a scanning mission. WALL•E chases EVE across the galaxy and inadvertently embarks on a space journey that ultimately decides the fate of humankind.



THE DESIGNER

Angus MacLane was the Directing Animator for the film WALL•E at Pixar Animation Studios. He was closely involved with the team that designed and built the title robot.

“I started building the LEGO® version of WALL•E around the same time he was being built in the computer at Pixar, in the late summer of 2005. The color scheme of the character wasn’t settled so I started building with all light gray. As we refined the robot’s design for the film, I would update my LEGO model. Once we got busier on the film, I had less time to build, so I put him on the shelf for a while.

Once we finished animation production in 2008, I rebuilt him with the proper colors. The original treads I used were too small and

pretty flimsy, but a LEGO bulldozer had been launched by then, which gave me my solution.

After I submitted the design to LEGO Ideas, I did a few more revisions to the model to make it more accurate to the character design. Having stared at this robot for so many years, I was extremely familiar with the proportions and functionality of WALL•E. Great input from LEGO Designer Steen Sig Andersen and the team at The LEGO Group, and from Andrew Stanton (the director of WALL•E), helped push the LEGO WALL•E to its final design.

It took a lot of iterations over almost a decade, but I’m really happy with how the final LEGO WALL•E turned out.”



WALL·E

WALL·E (de l'anglais Waste Allocation Load Lifter Earth-class), est le dernier robot qui reste sur Terre. Il passe ses journées à nettoyer la planète, une pile de débris à la fois. Pendant les 700 ans de son existence, WALL·E a développé une personnalité et il se sent extrêmement seul. Puis il rencontre EVE, un beau robot de recherche envoyé sur Terre pour une mission de repérage. WALL·E poursuit EVE dans la galaxie et s'embarque par erreur pour un voyage spatial qui détermine finalement le destin de l'humanité.

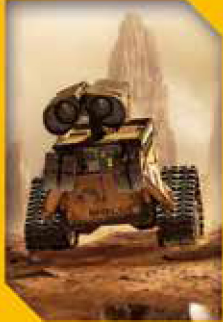

LE DESIGNER

Angus MacLane était le directeur de l'animation pour le film WALL•E chez Pixar Animation Studios. Il a collaboré étroitement avec l'équipe qui a conçu et construit le petit robot.

« J'ai commencé à construire la version LEGO® de WALL•E au moment même où il a été conçu par ordinateur chez Pixar, à la fin de l'été 2005. Les couleurs du personnage n'étaient pas fixées, donc j'ai commencé à le construire en gris clair. Alors que nous affinions le design du robot pour le film, je mettais à jour mon modèle LEGO. Lorsque nous avons été plus occupés par le film, j'avais moins de temps pour construire, donc j'ai dû laisser le modèle sur une étagère pendant un temps.

Quand nous avons fini la production de l'animation en 2008, je l'ai reconstruit avec les couleurs correctes. Les chenilles originales

que j'avais utilisées étaient trop petites et assez fragiles, mais un bulldozer LEGO avait été lancé entre-temps et il m'a donné la solution.

Après avoir envoyé le design à LEGO Ideas, j'ai encore révisé un peu le modèle pour le rendre plus fidèle au design du personnage. Ayant regardé ce robot pendant de nombreuses années, je connaissais très bien les proportions et les fonctionnalités de WALL•E. Une aide précieuse du designer de produits LEGO Steen Sig Andersen, de l'équipe du Groupe LEGO et d'Andrew Stanton (le réalisateur de WALL•E), a contribué à créer le design final de LEGO WALL•E.

Il a fallu beaucoup de modifications au cours d'une décennie mais je suis vraiment heureux du résultat final de LEGO WALL•E. »



WALL·E

WALL·E (siglas en inglés de «Elevador para asignación de carga residual clase Tierra») es el último robot que queda en la Tierra. Pasa sus días poniendo en orden el planeta y limpiándolo de basura. A lo largo de los 700 años que ha existido, WALL·E ha desarrollado una personalidad y ahora se siente un poco solo. Entonces conoce a EVE, un moderno robot enviado a la Tierra en misión de exploración. WALL·E persigue a EVE por toda la galaxia y se embarca por accidente en un viaje espacial que decidirá el destino de la humanidad.

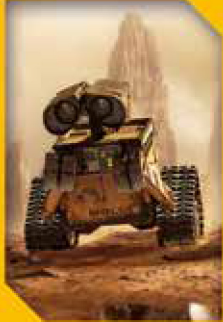

EL DISEÑADOR

Angus MacLane fue director de animación para la película WALL•E en Pixar Animation Studios. Mantuvo una estrecha relación con el equipo que diseñó y construyó el pequeño robot.

«Comencé a construir la versión LEGO® de WALL•E casi al mismo tiempo que lo diseñábamos por computador en Pixar, a finales del verano de 2005. Los colores del personaje aún no estaban decididos, así que lo construí todo en gris claro. Conforme íbamos puliendo el diseño del robot para la película, yo actualizaba mi modelo LEGO. Más tarde, cuando empezamos con la película, tuve menos tiempo para construir, así que lo coloqué en una estantería.

Terminamos la animación en 2008 y decidí reconstruirlo entonces con los colores

correctos. Las orugas que usé al principio eran muy pequeñas y bastante frágiles, pero LEGO puso a la venta un bulldozer por aquel entonces y esa fue la solución.

Después de enviar el diseño a LEGO Ideas, hice un par de cambios en el modelo para que fuese más fiel al diseño del personaje. Había pasado tantos años contemplando el robot que estaba muy familiarizado con las proporciones y las funciones de WALL•E. La inestimable ayuda de Steen Sig Andersen (diseñador de LEGO), el equipo de The LEGO Group y Andrew Stanton (director de WALL•E) condujo a la versión final del WALL•E de LEGO.

Hicieron falta muchas pruebas y casi una década, pero estoy muy satisfecho con el resultado final del WALL•E de LEGO».

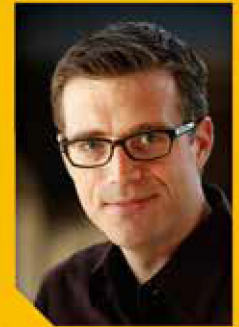

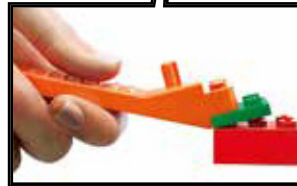
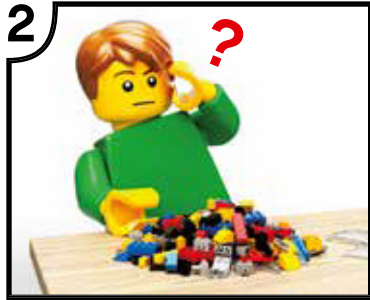

LEGO.com/brickseparator

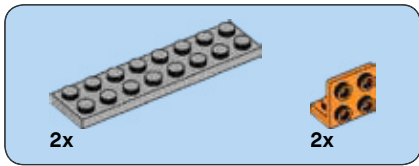

1

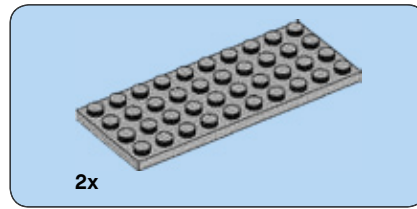
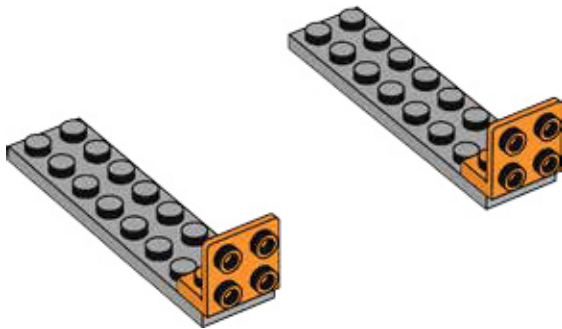

2

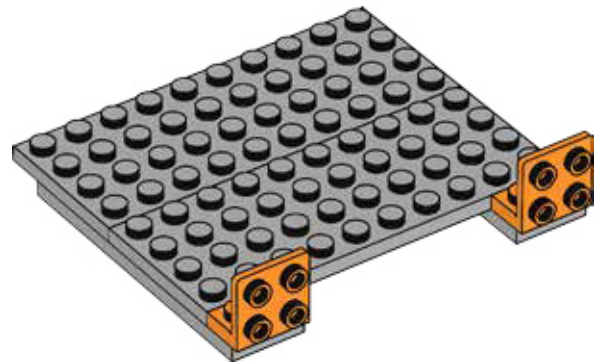



4x

3

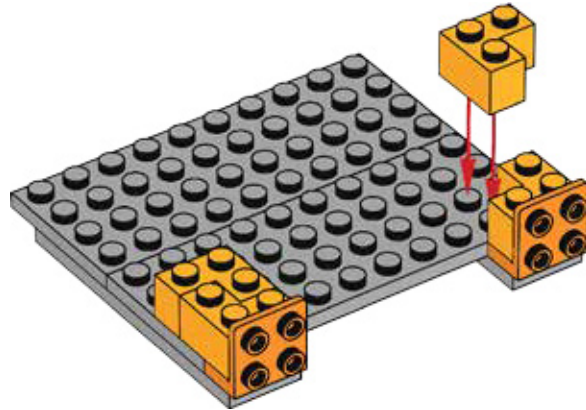



4

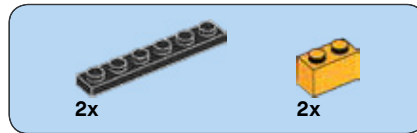
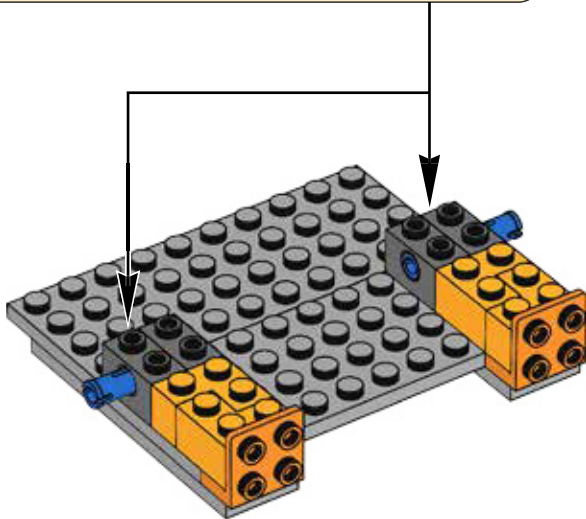
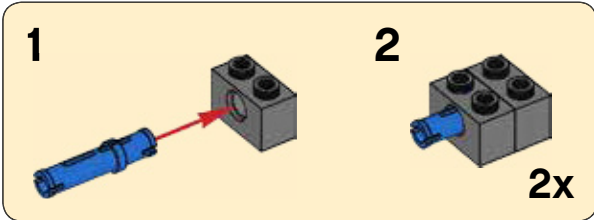

5

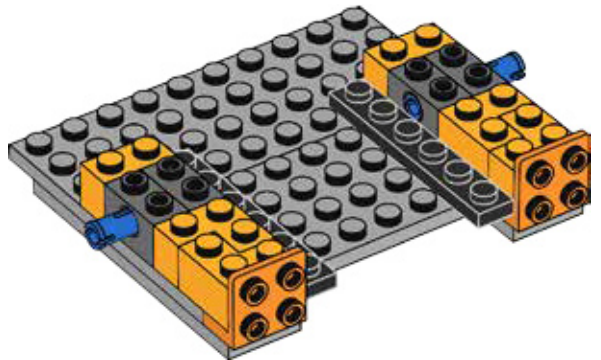



6

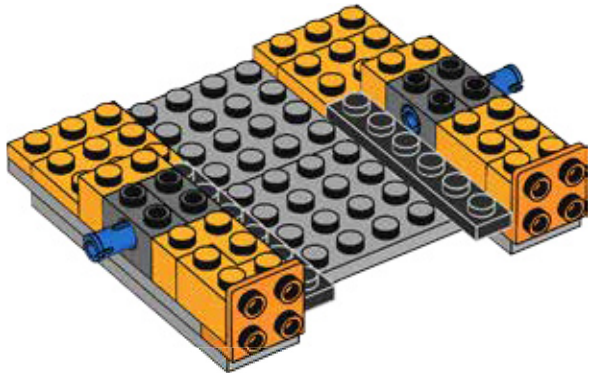

7

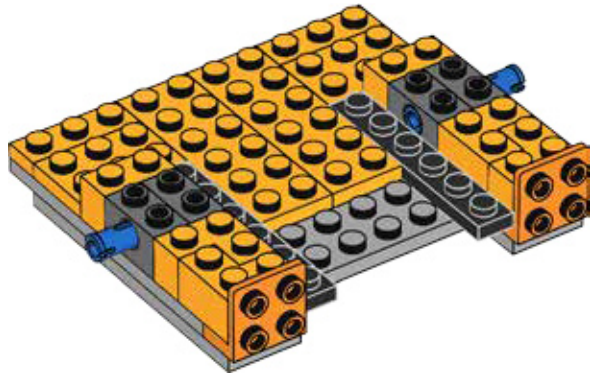

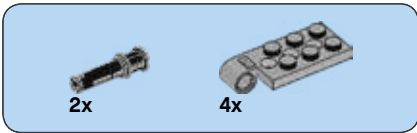

8

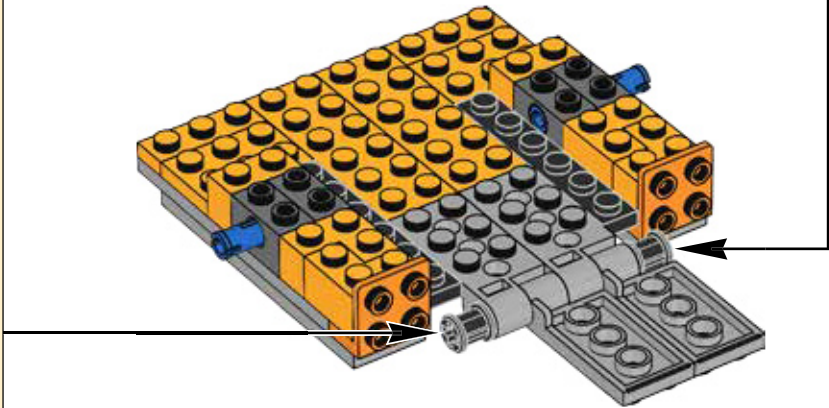
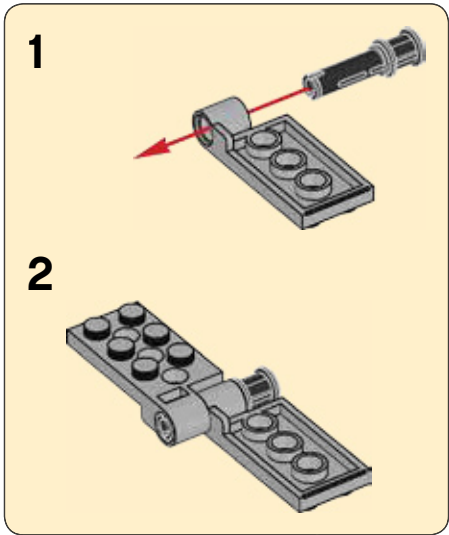
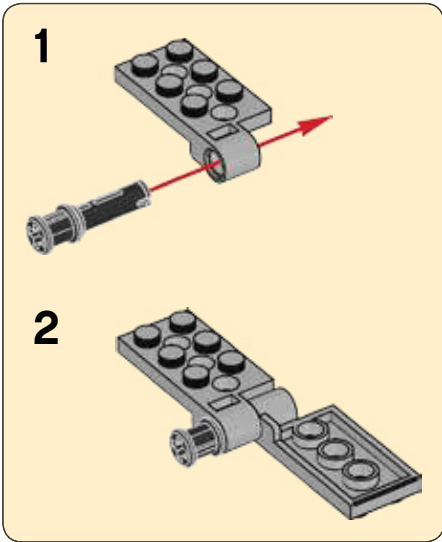

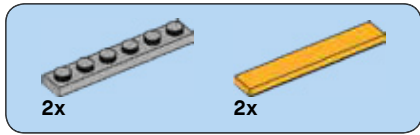

9

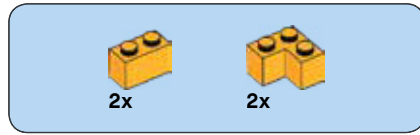
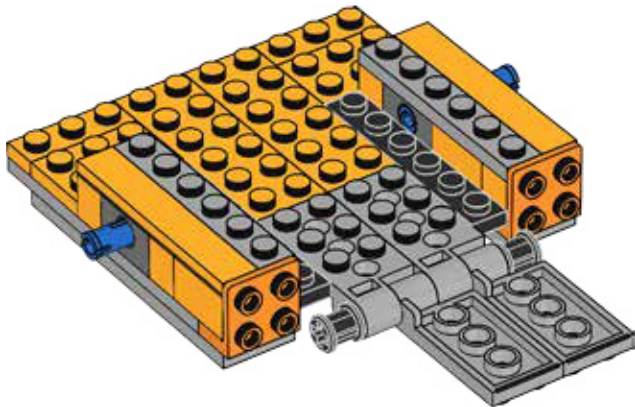

10

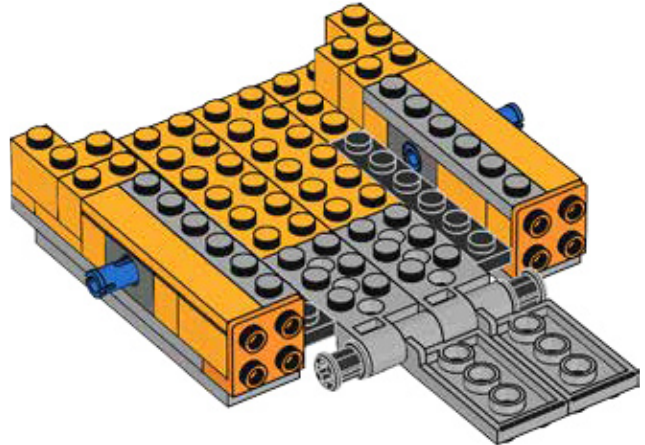

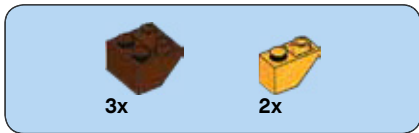

11

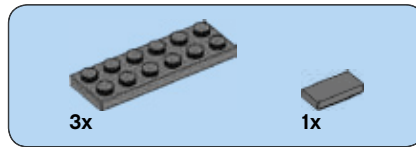
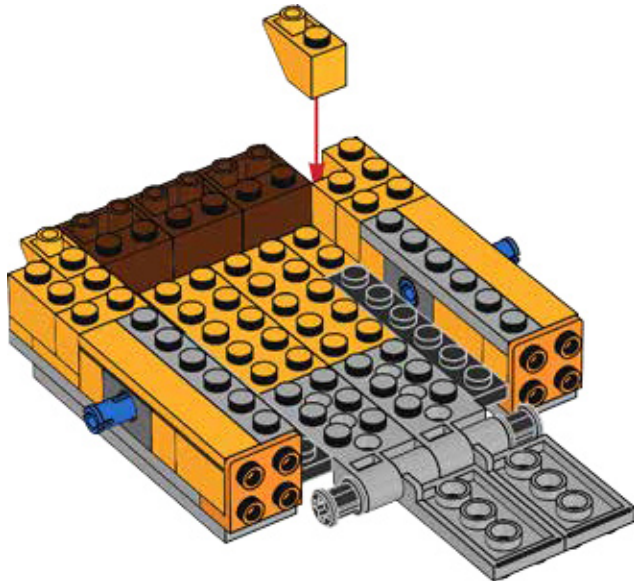

12

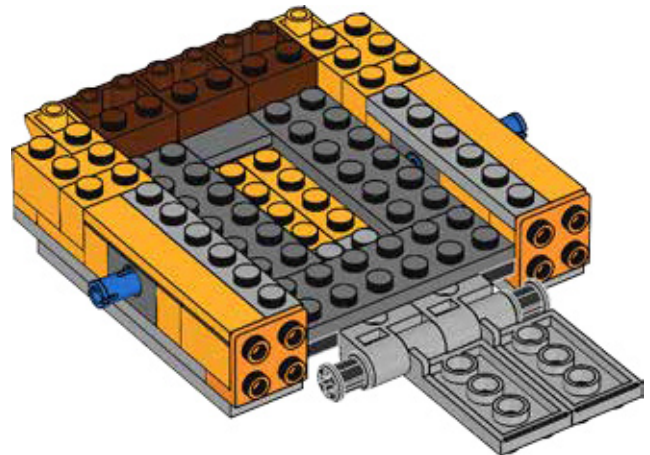

13

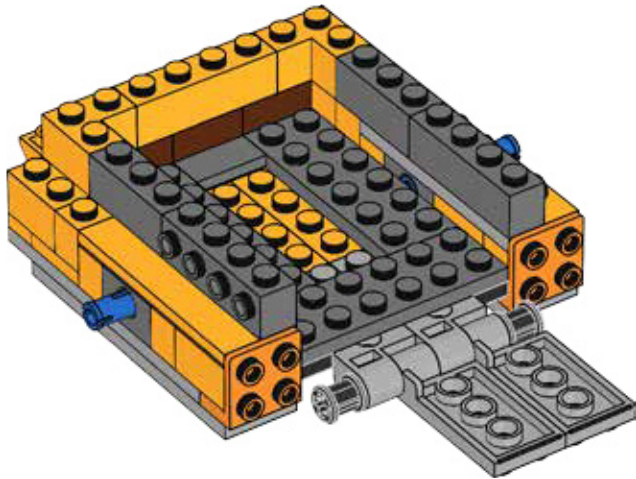
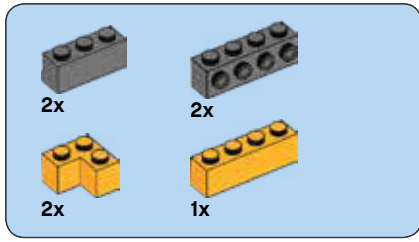

14

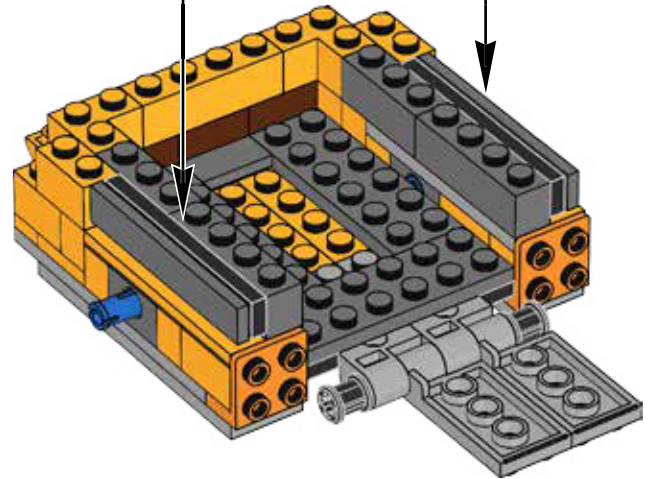
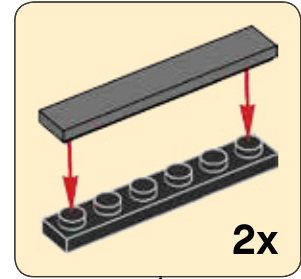
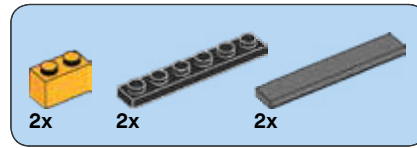

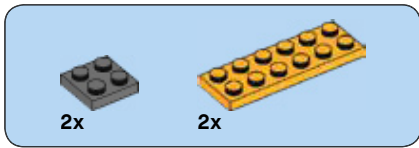

15

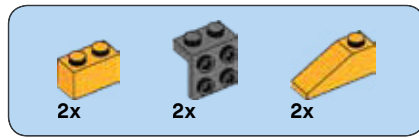
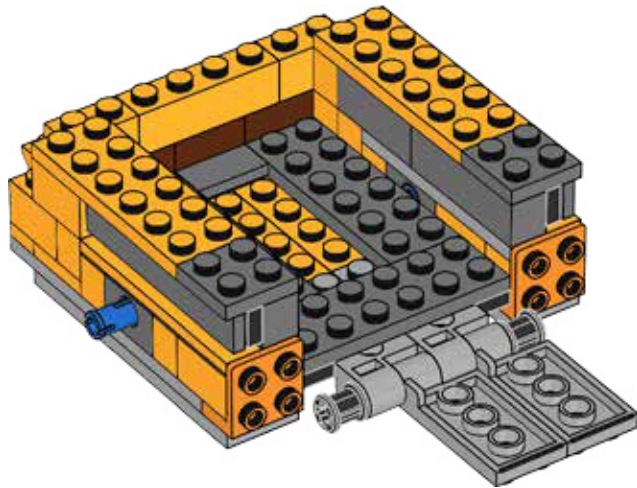

16

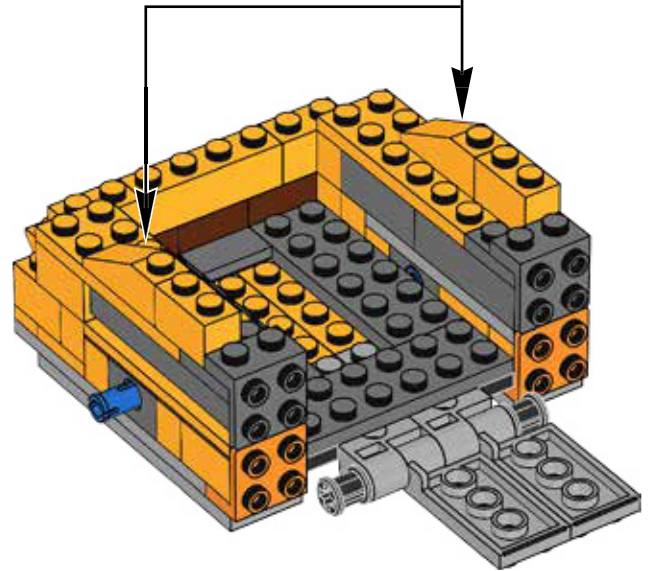
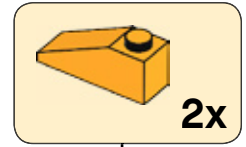

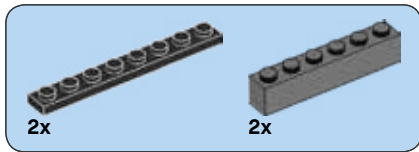

17

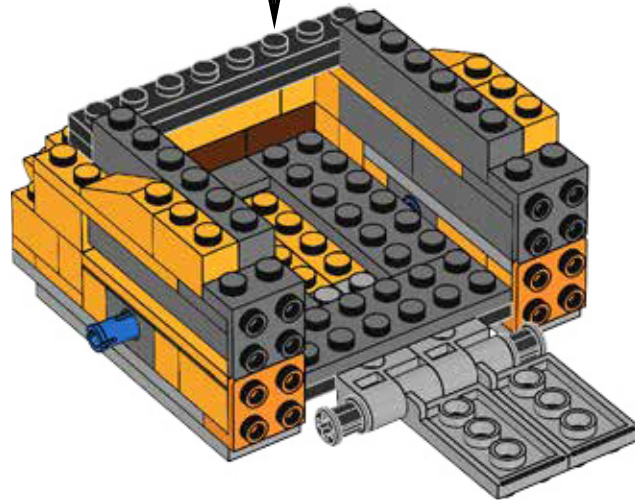
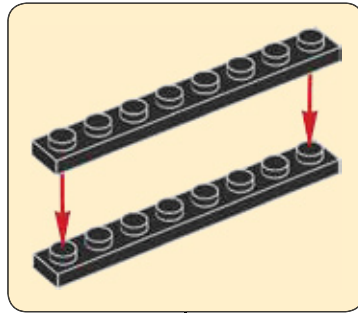

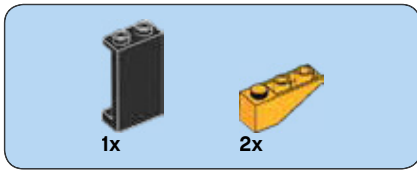

18

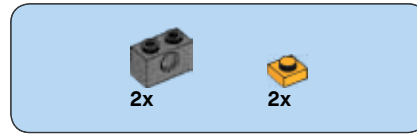
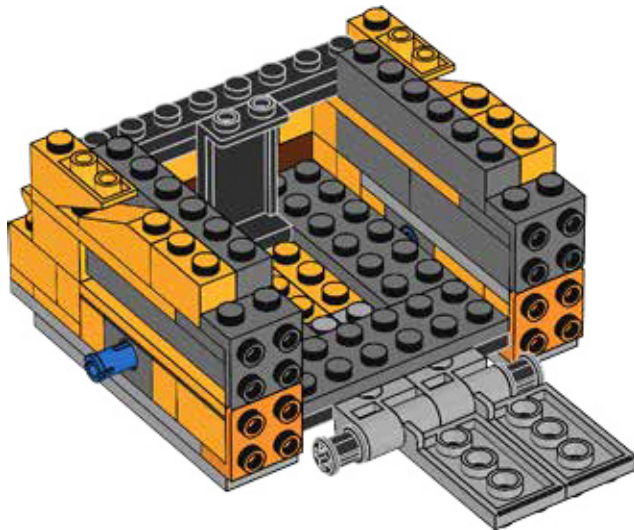

19

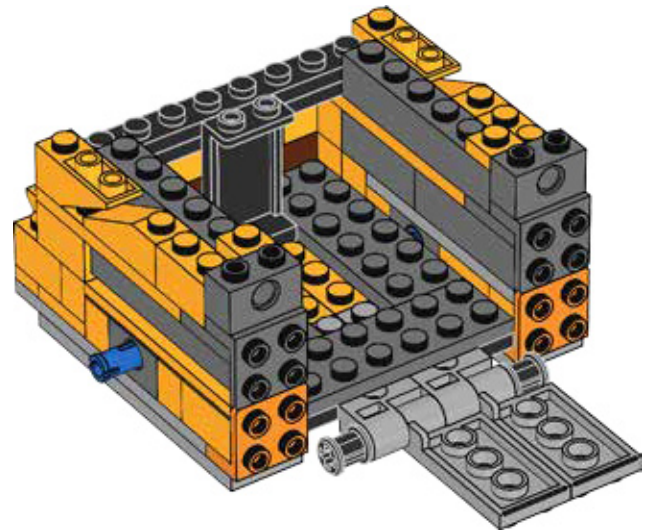



2x

20

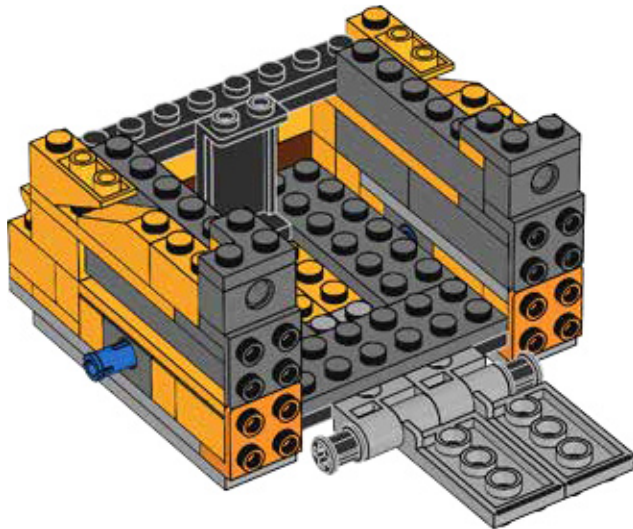

2x



2x

21

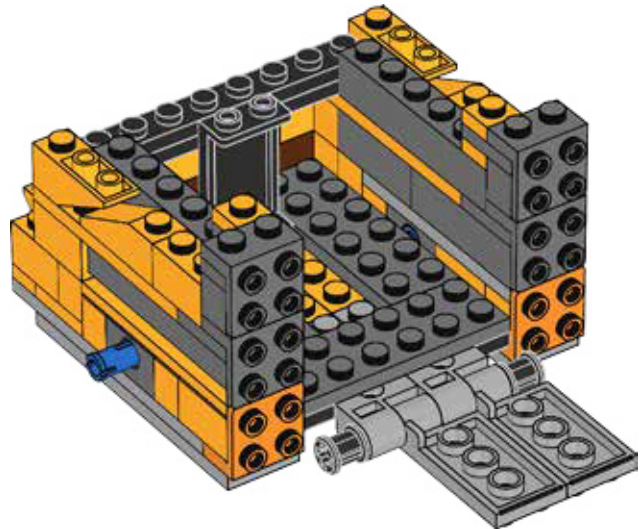

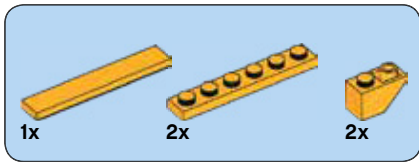

22

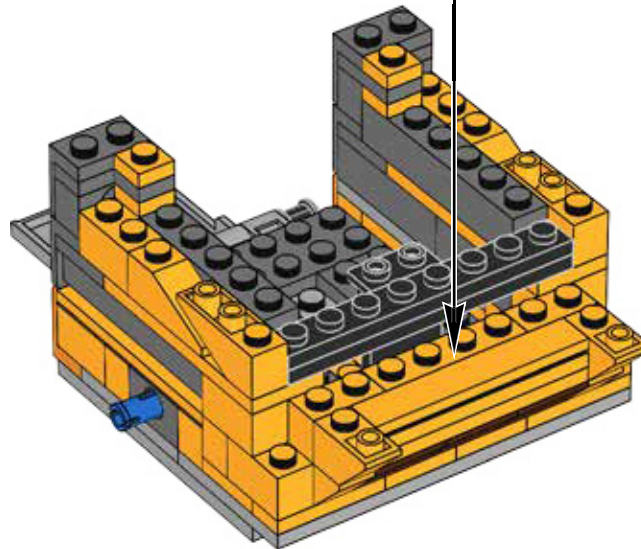
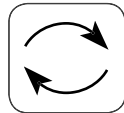
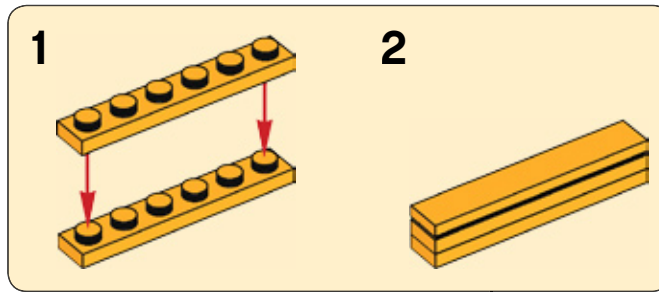



2x



2x



2x

23

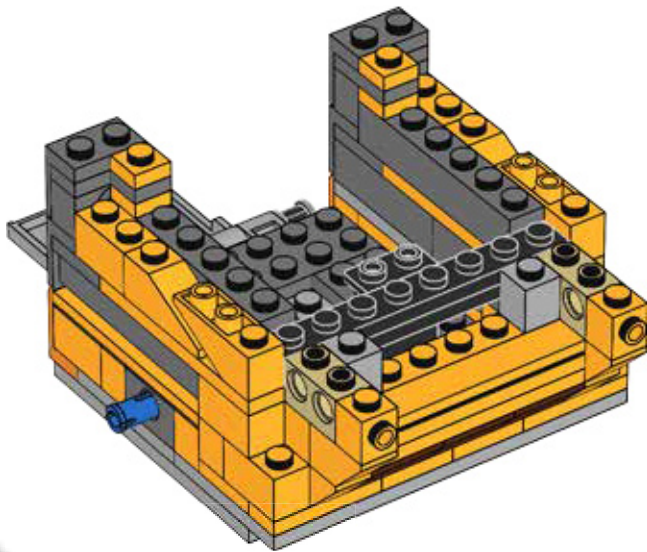

4x



2x



2x

24

1

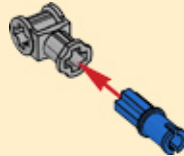

2

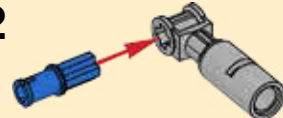

2x

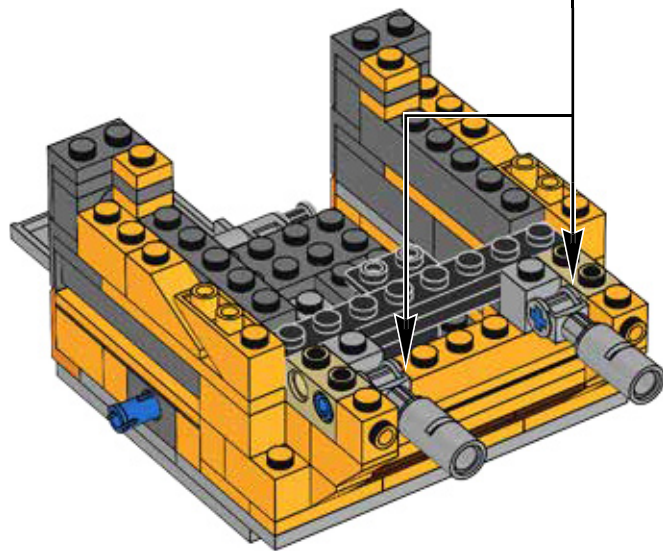



25

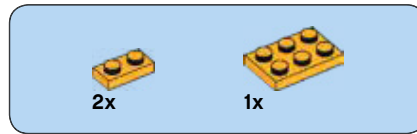
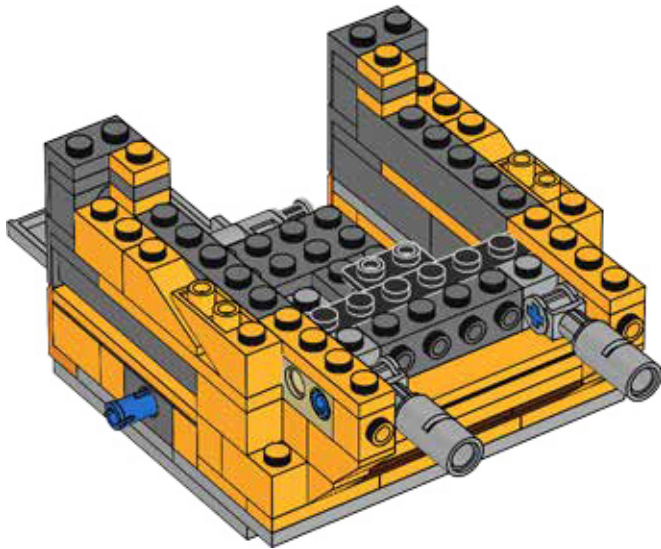

26

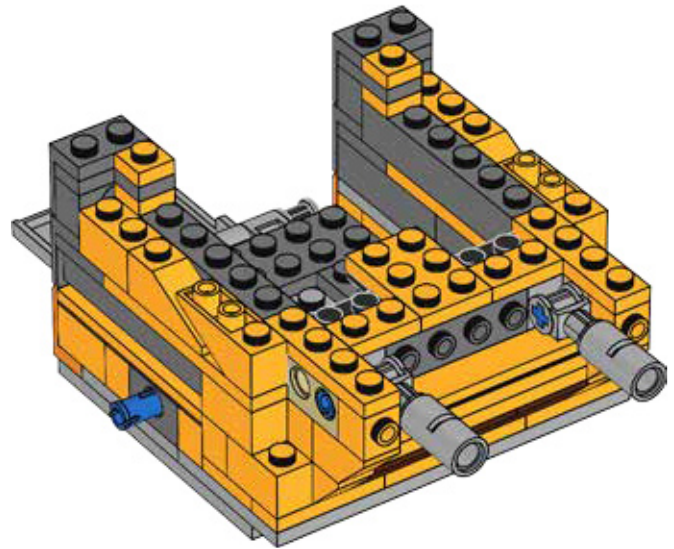



27

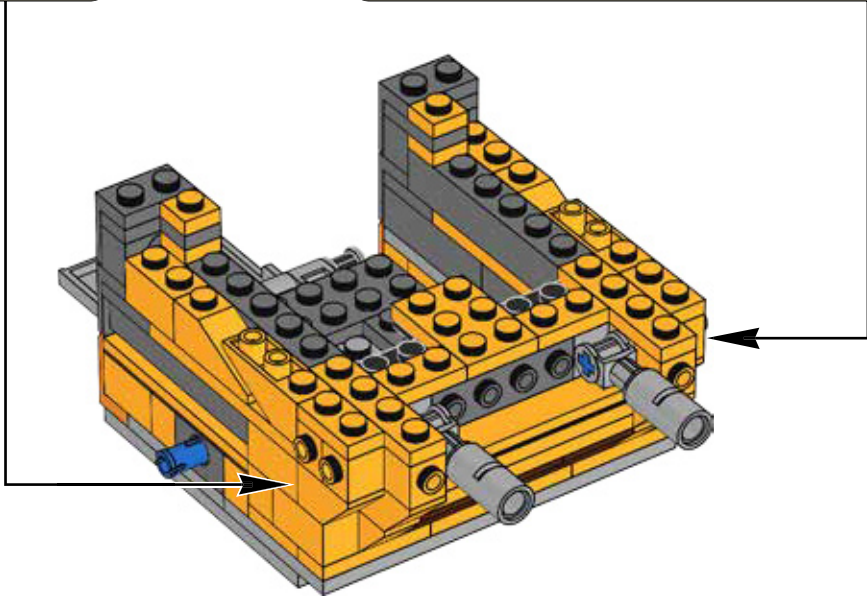
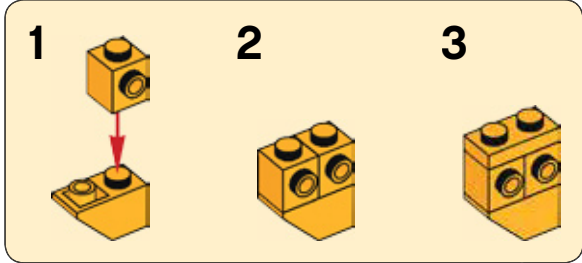
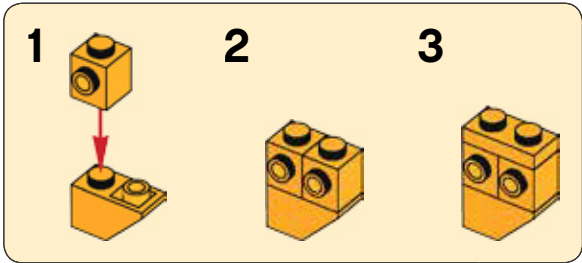

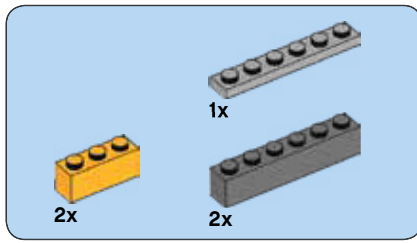

28

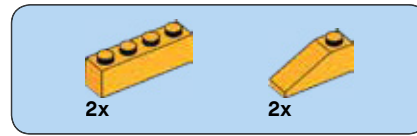
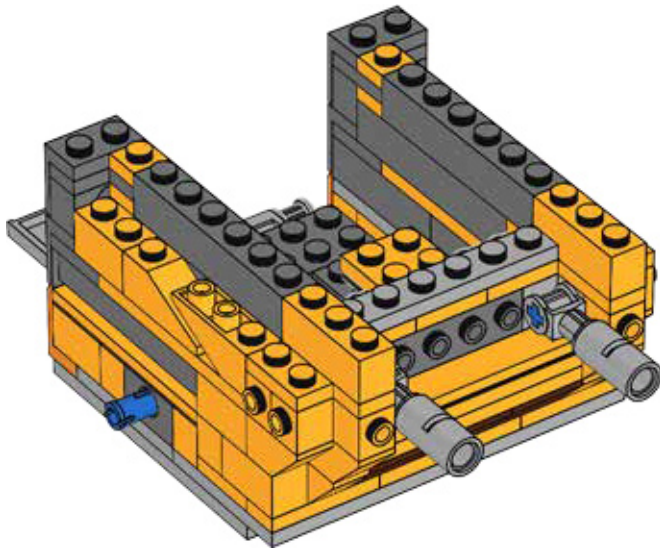

29

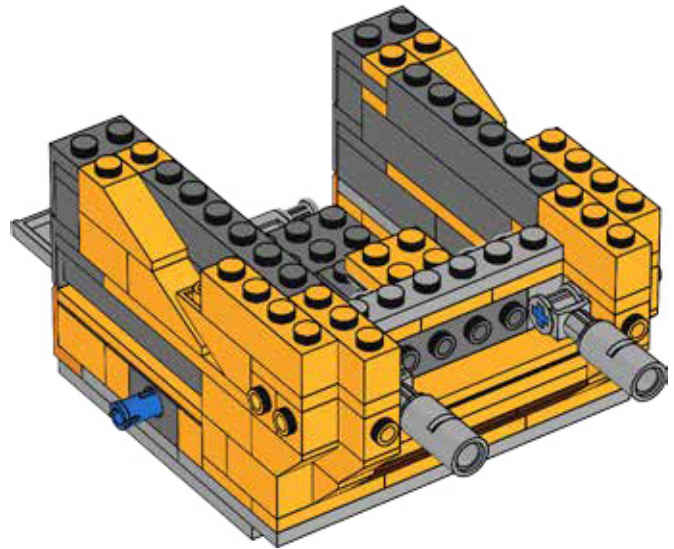



2x

30

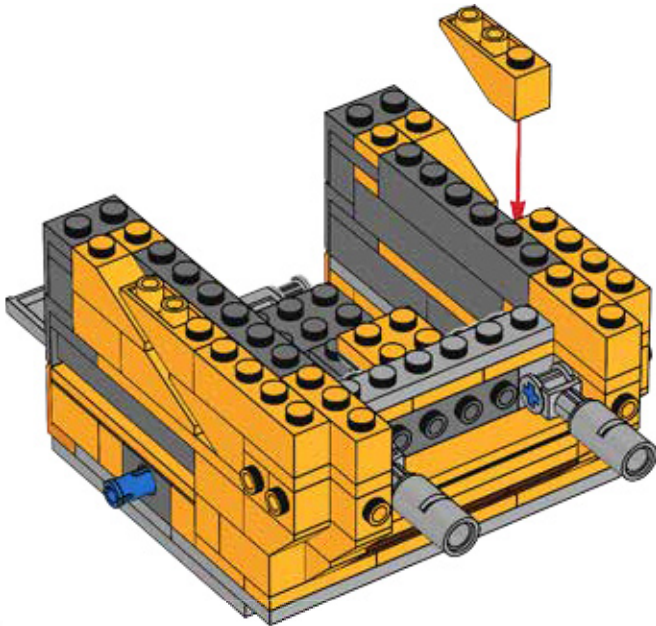

1x



2x



2x

31

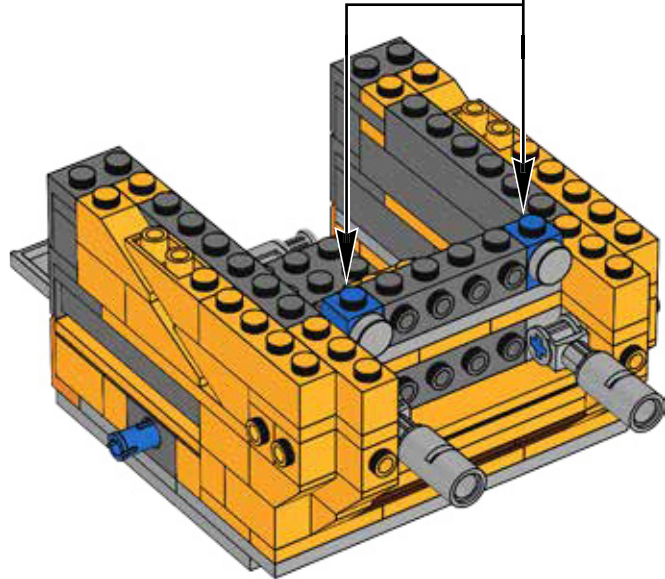
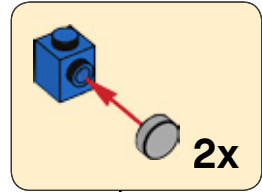

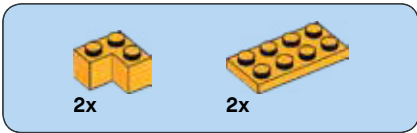

32

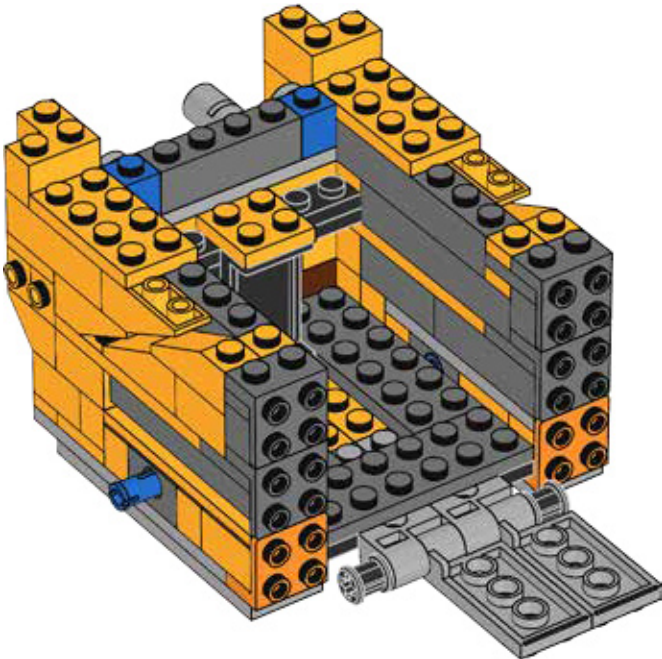
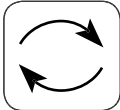

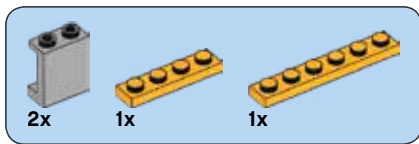

33

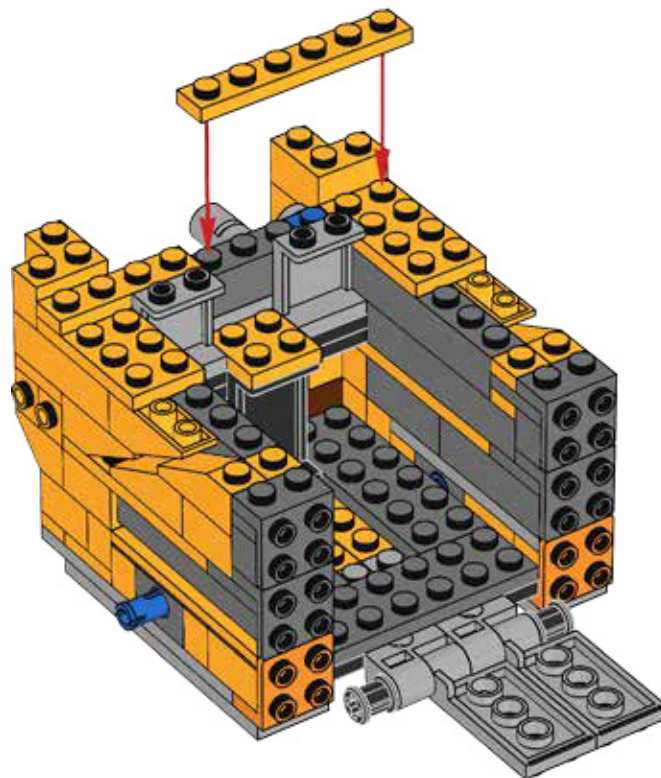



34

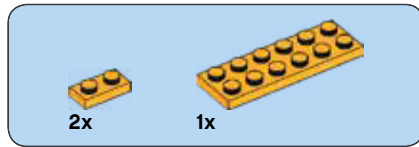
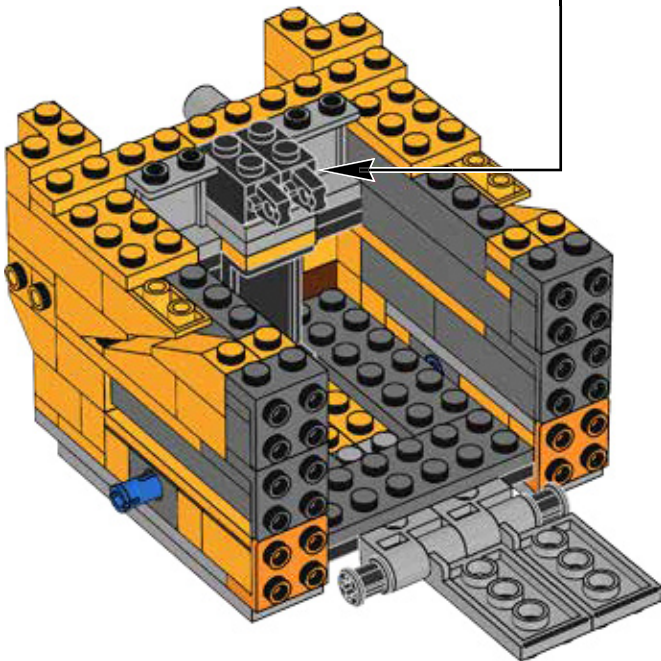
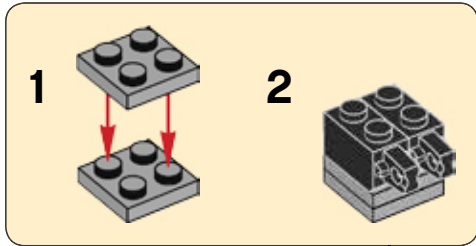

35

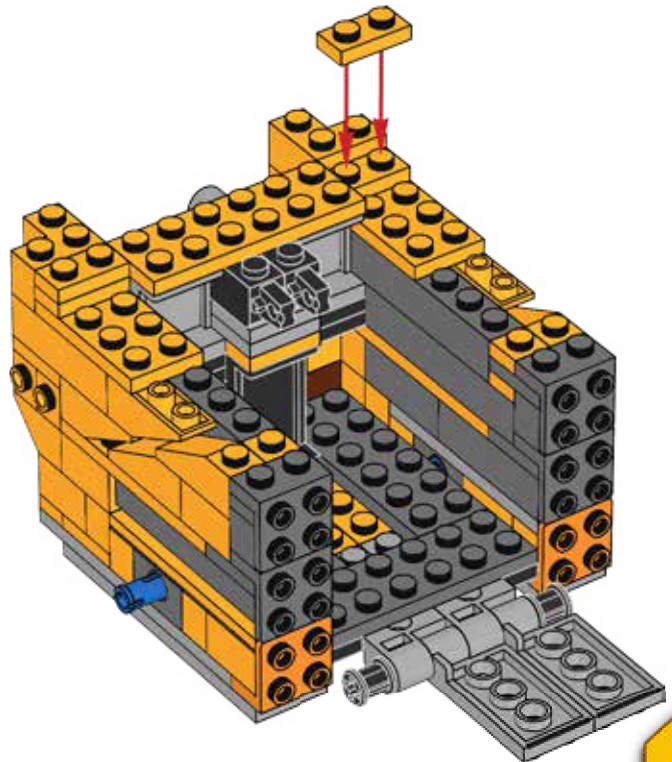



2x

36

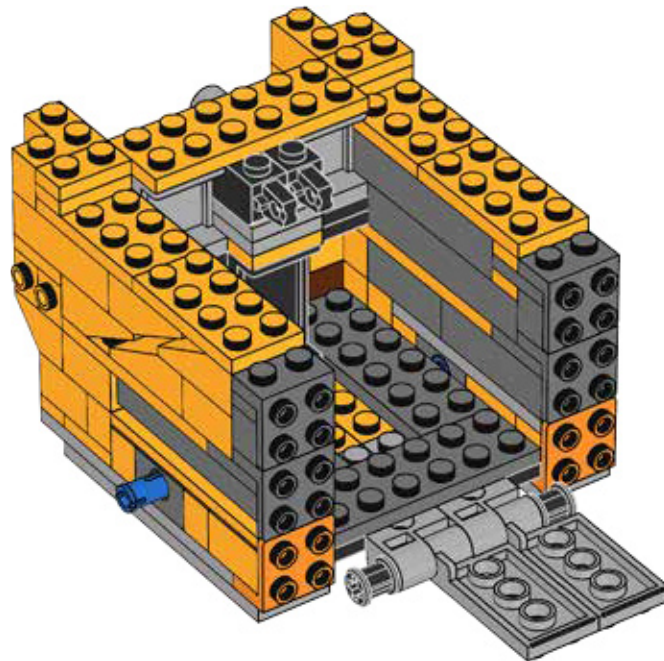

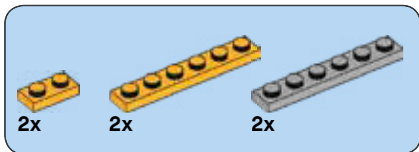

37

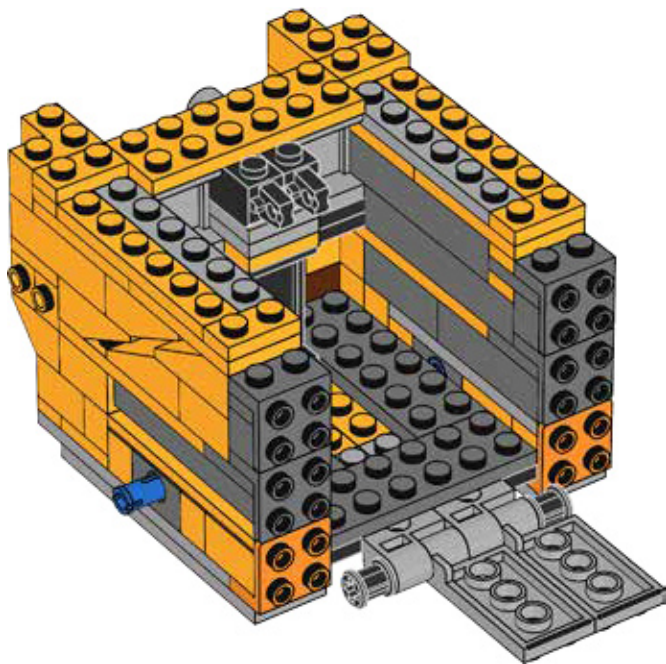

38

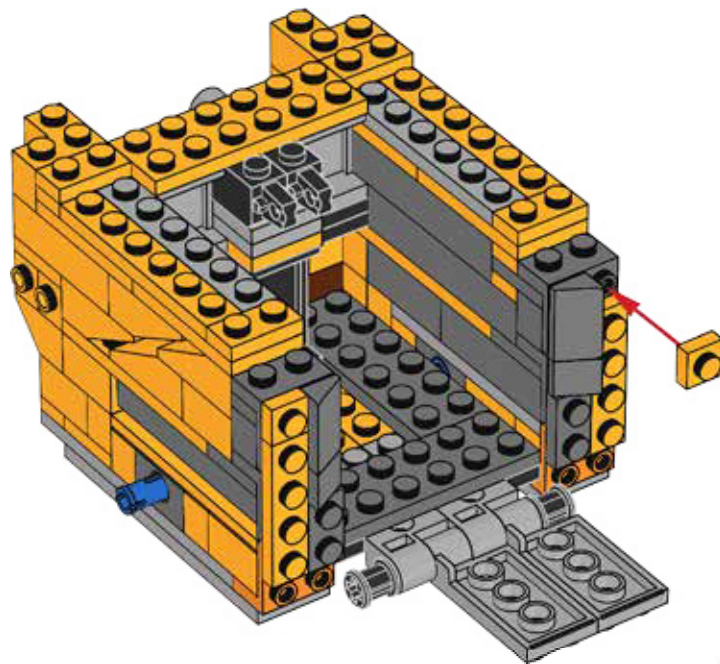

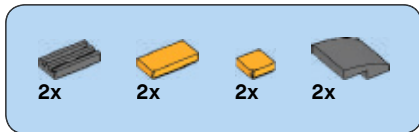

39

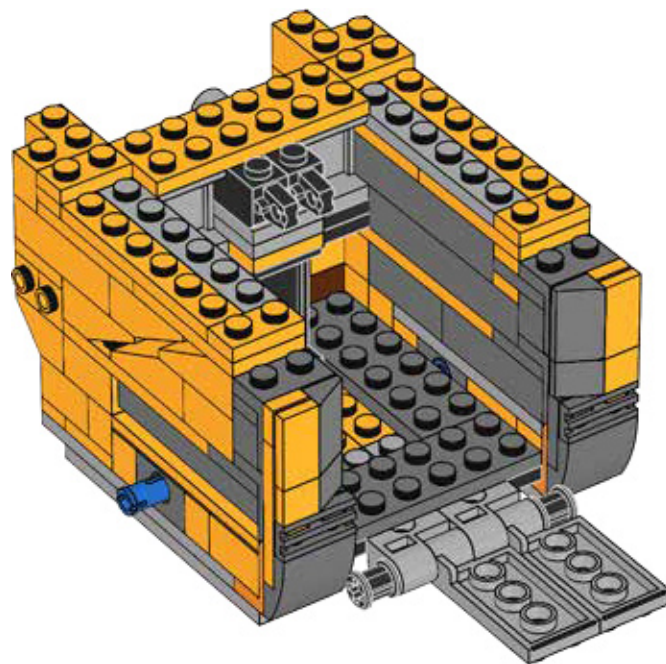

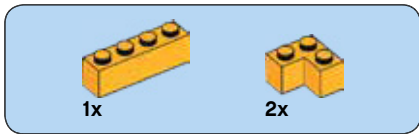

40

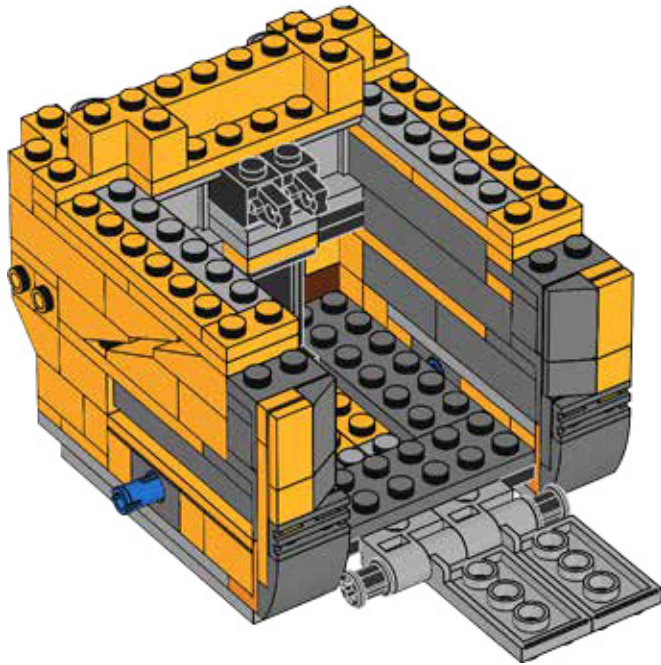

41

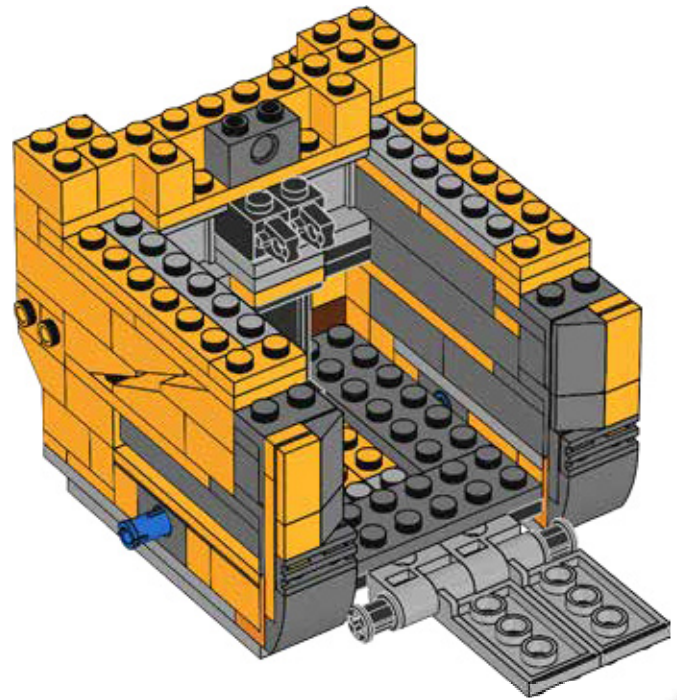

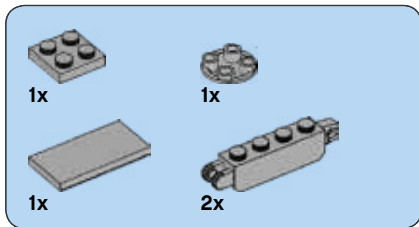

42

1



2

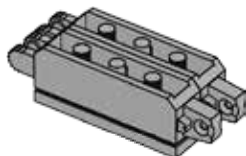

3

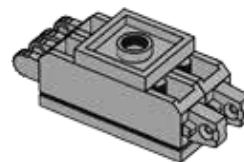

4

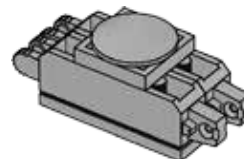

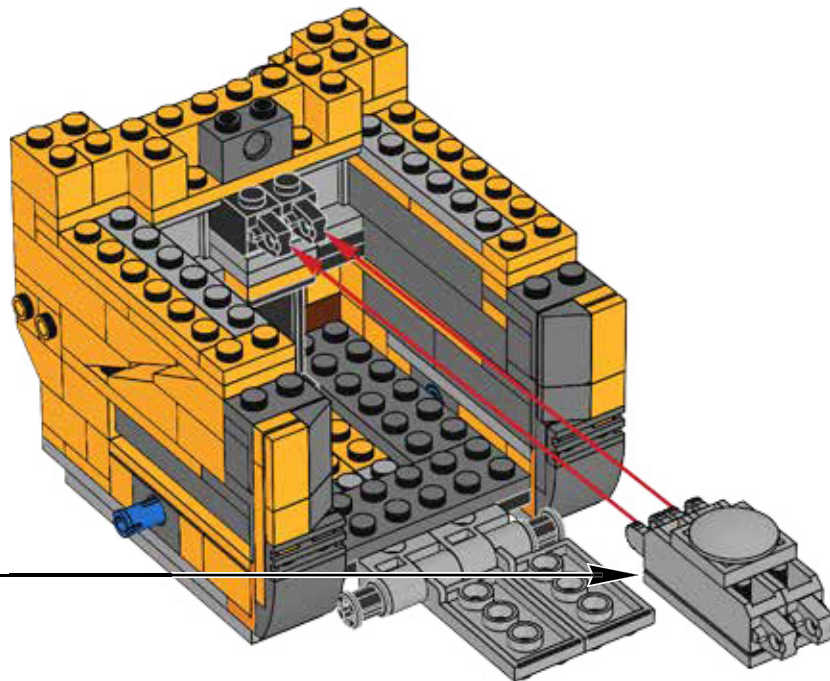

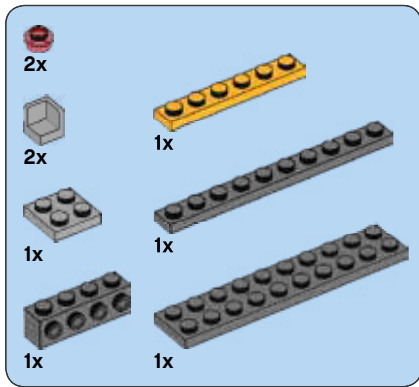

43

1

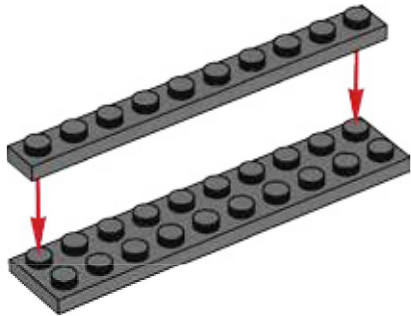

2

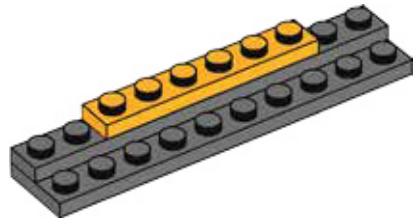

3

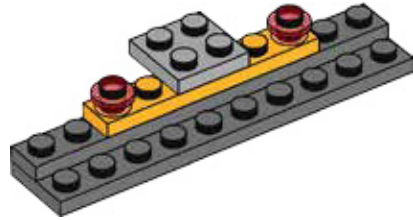

4

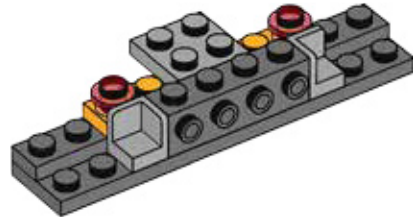

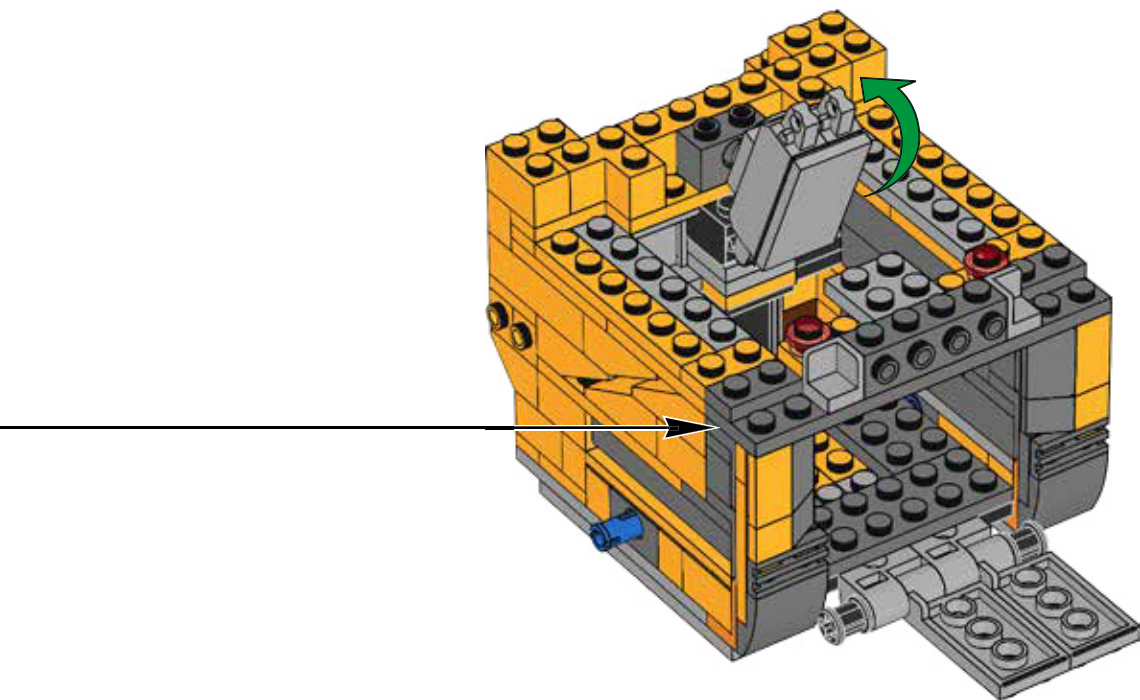

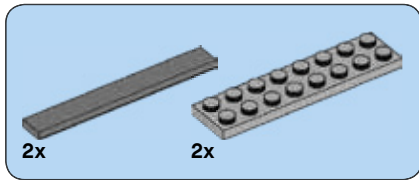

44

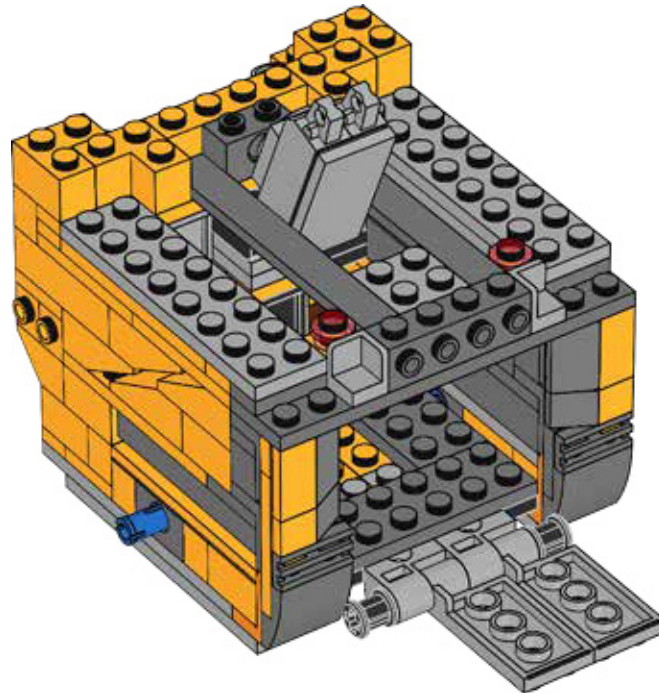



1x



1x

45

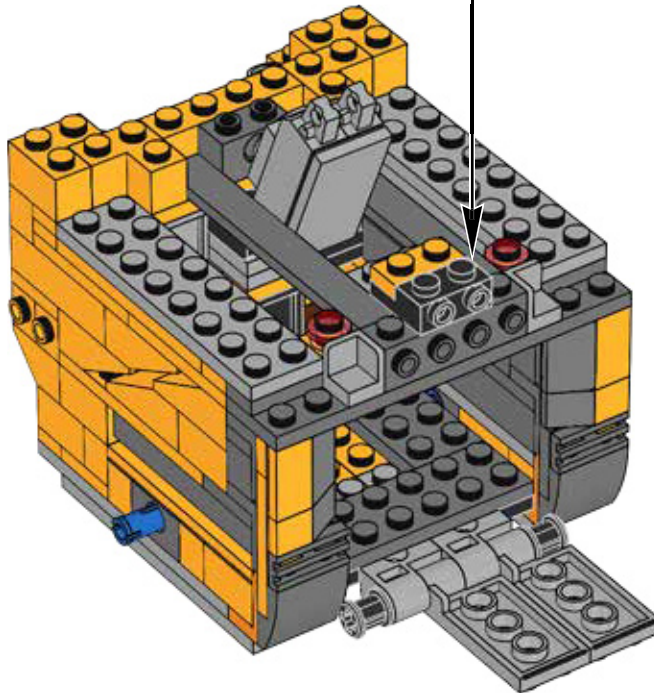
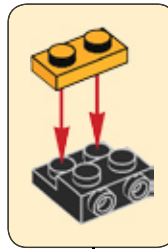



46

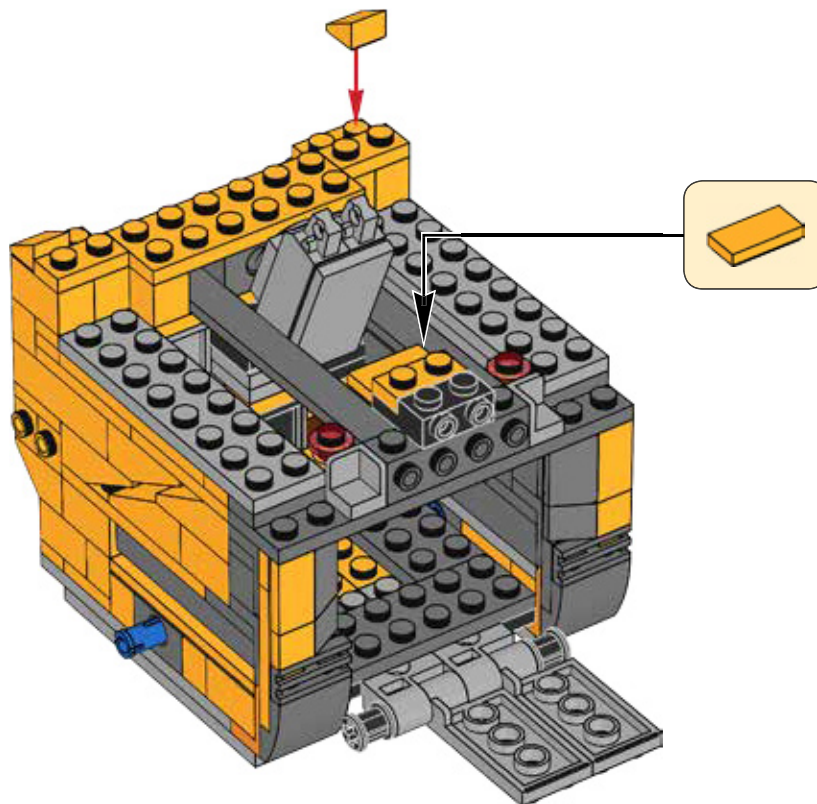

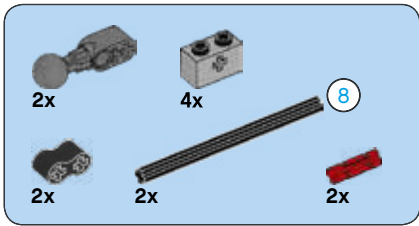

47

1

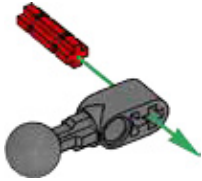

2

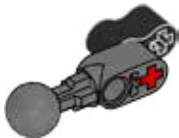

3

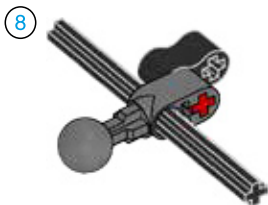

4

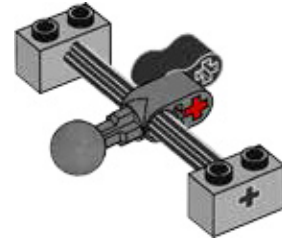

2x

5

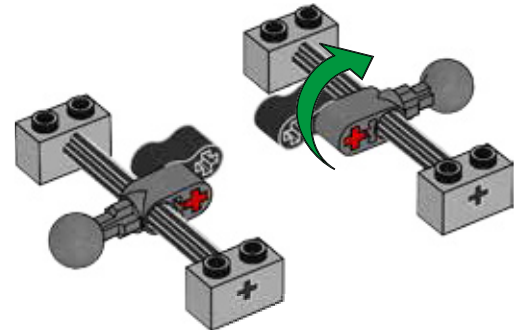

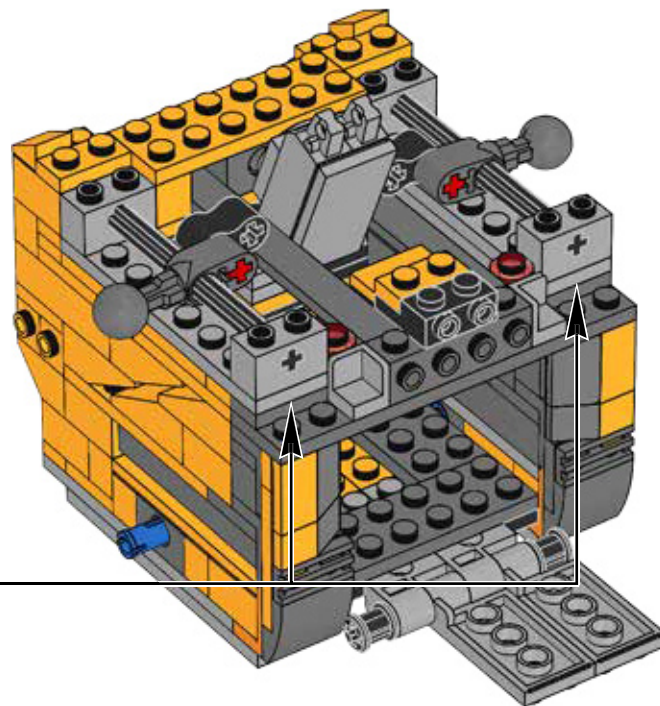

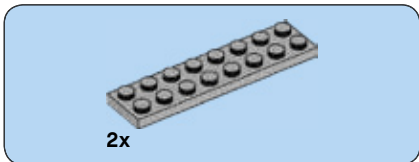

48

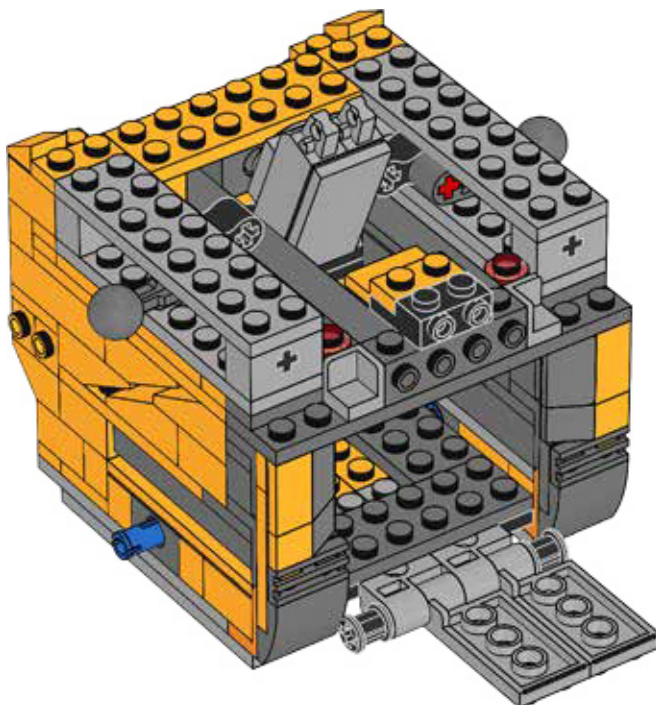



49

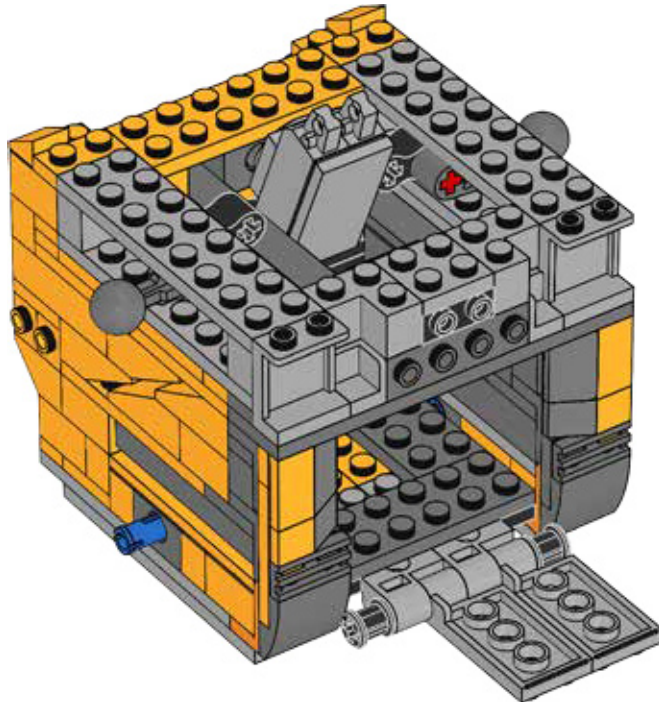

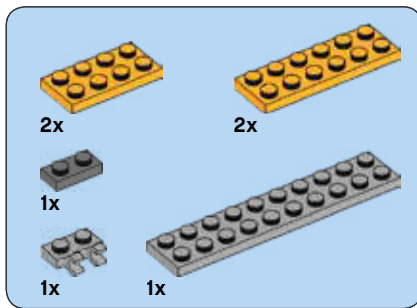

50

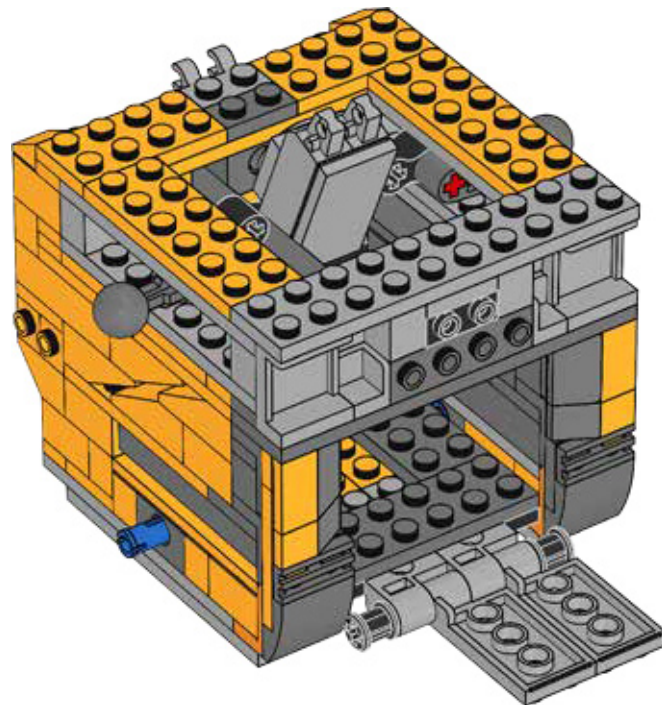

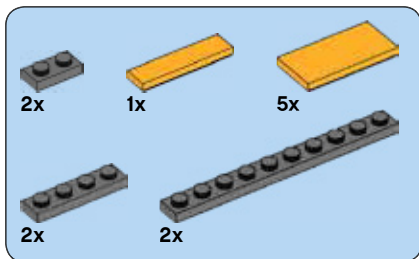

51

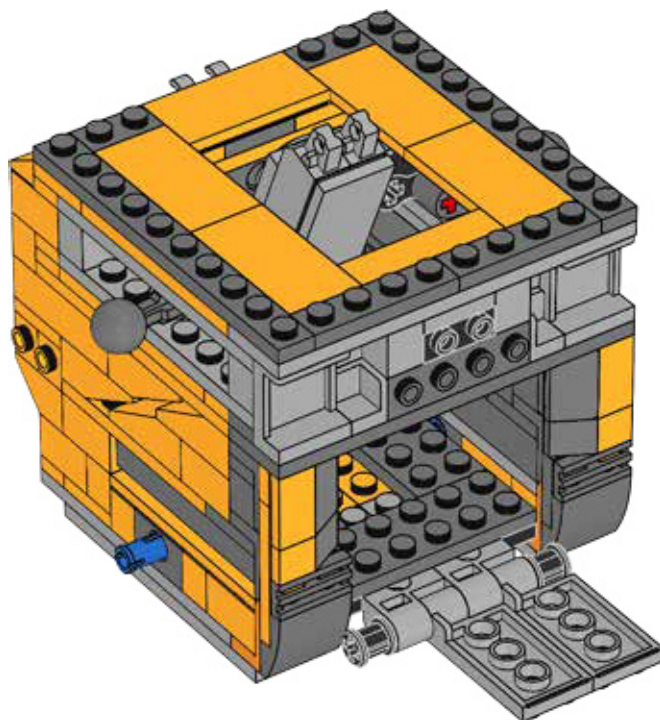

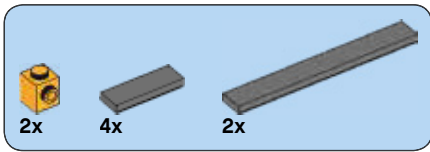

52

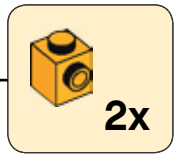
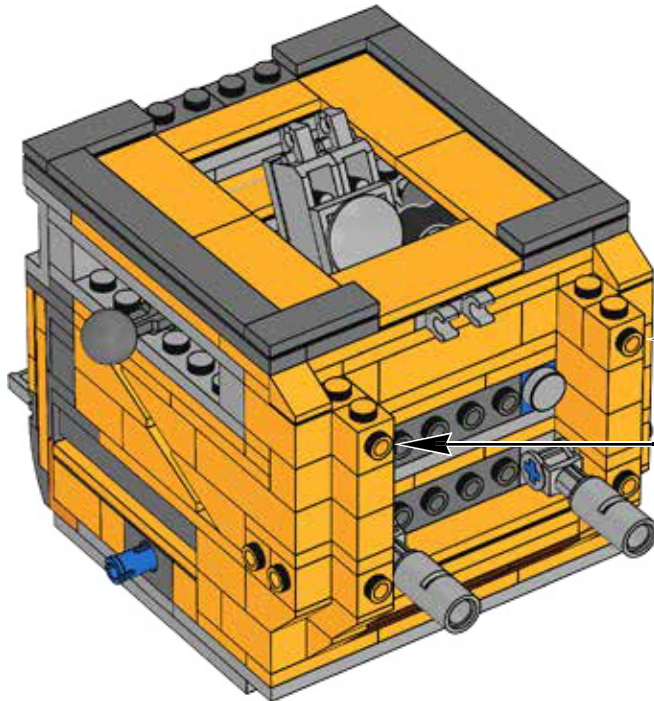
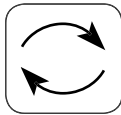



2x



2x

53

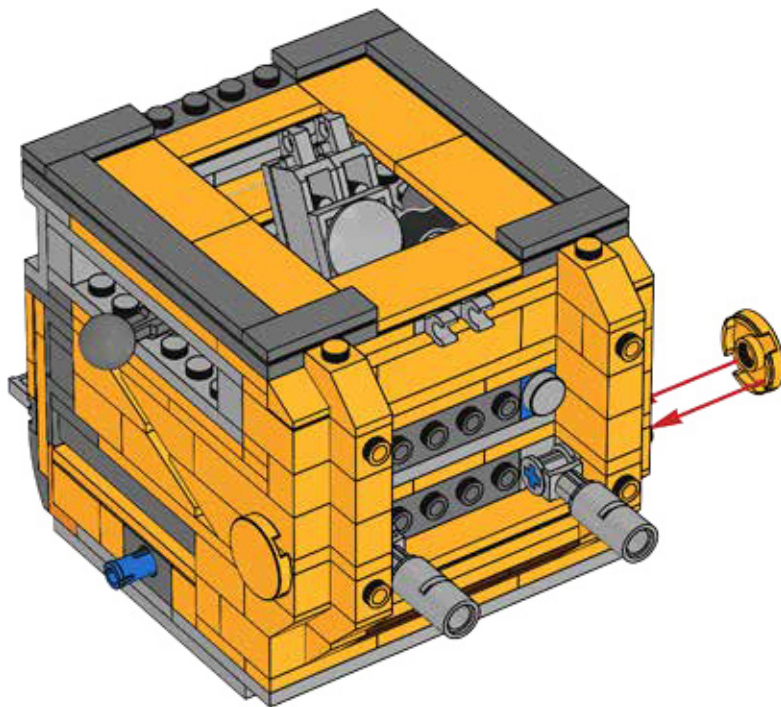

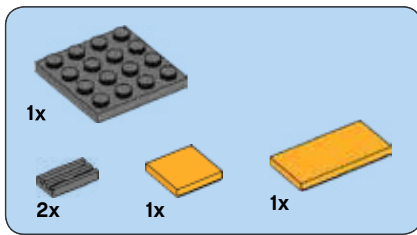

54

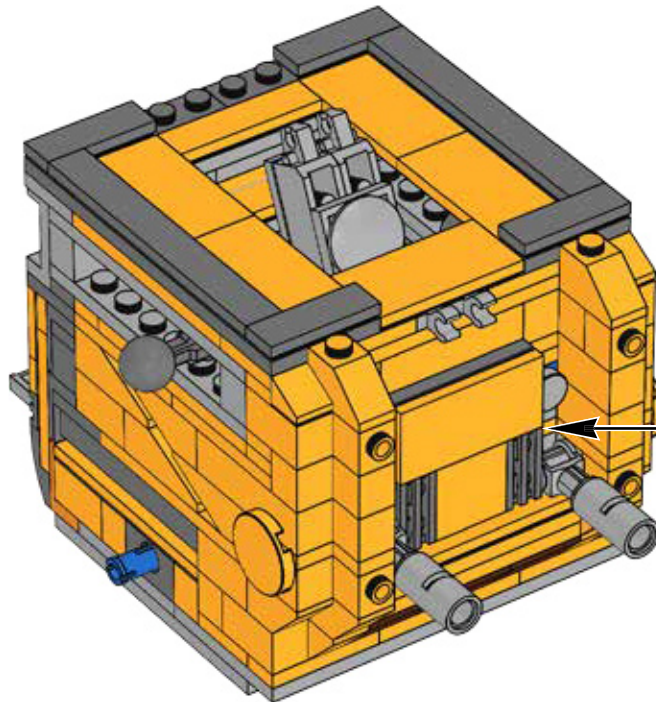
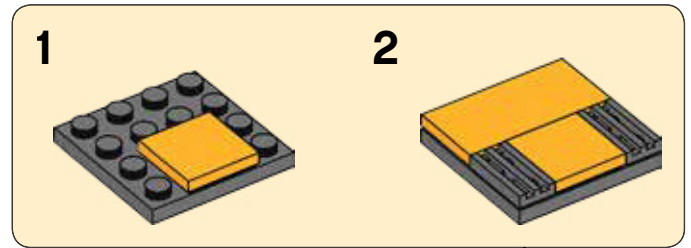



55

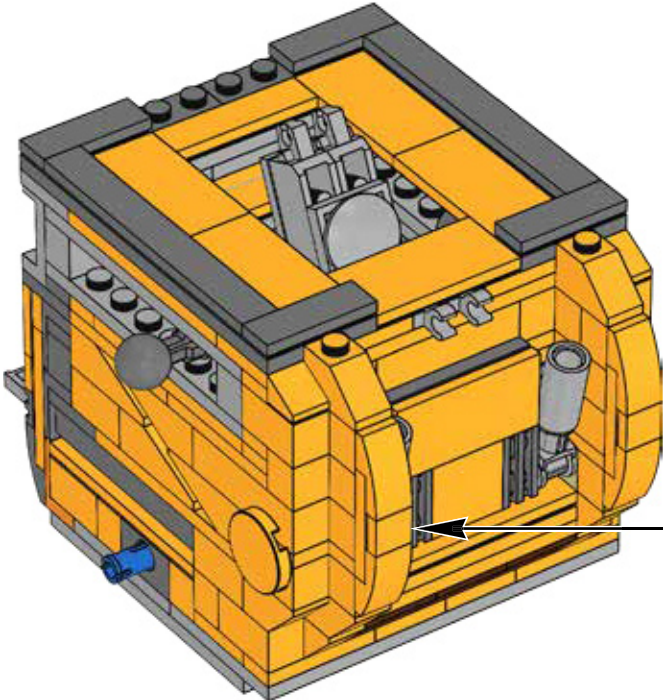
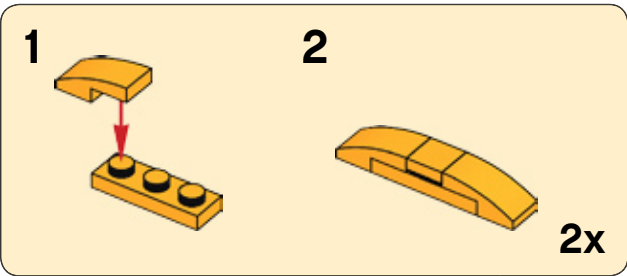

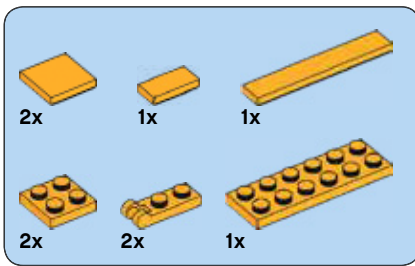

56

1

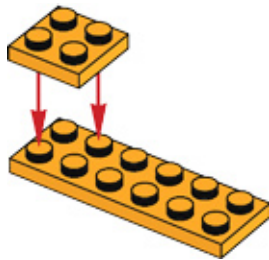

2

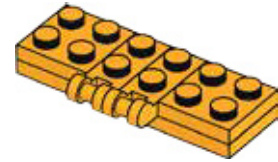

3

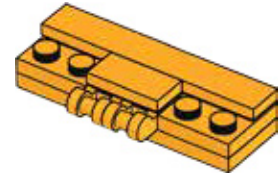

4

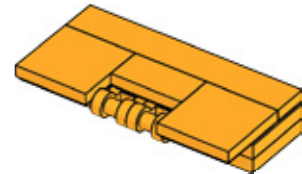

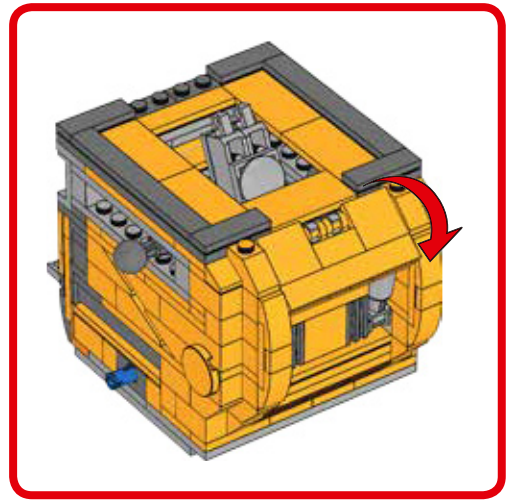
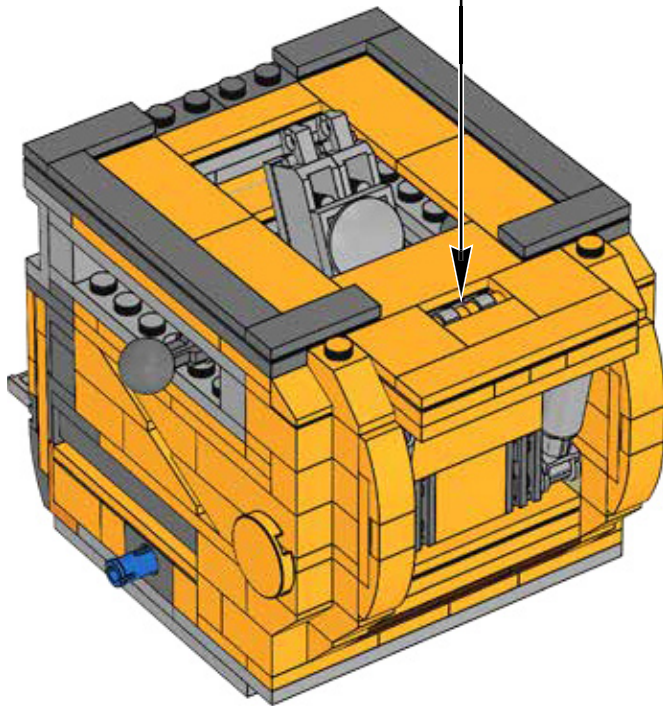

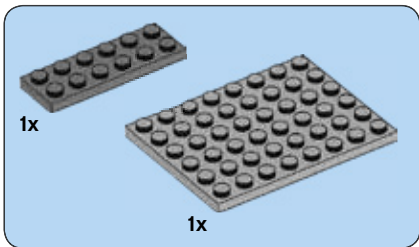

57

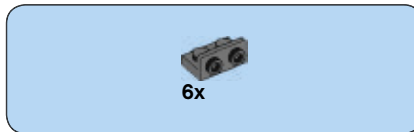

58

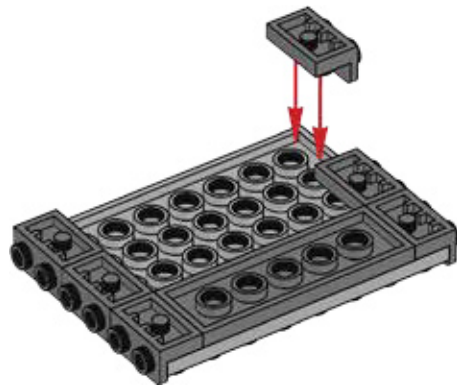

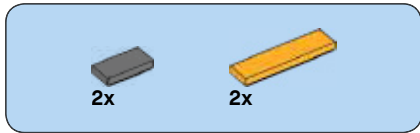

59

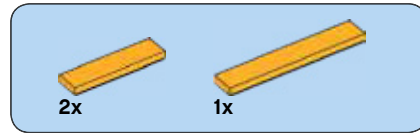
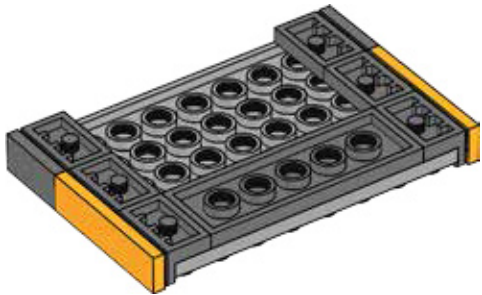

60

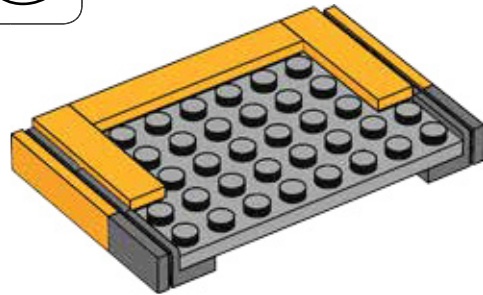
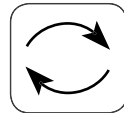

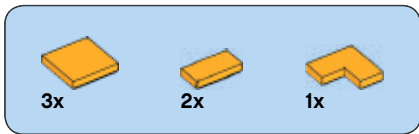

61

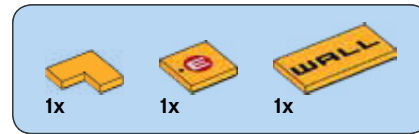
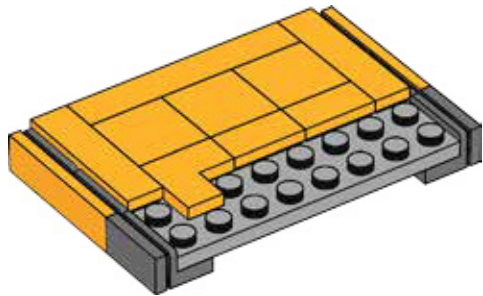

62

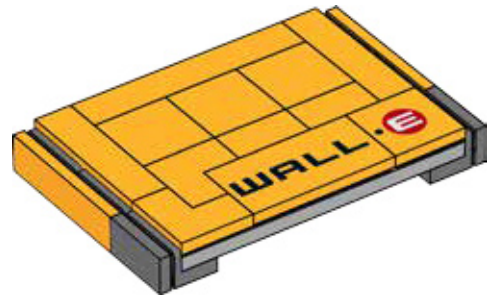

63

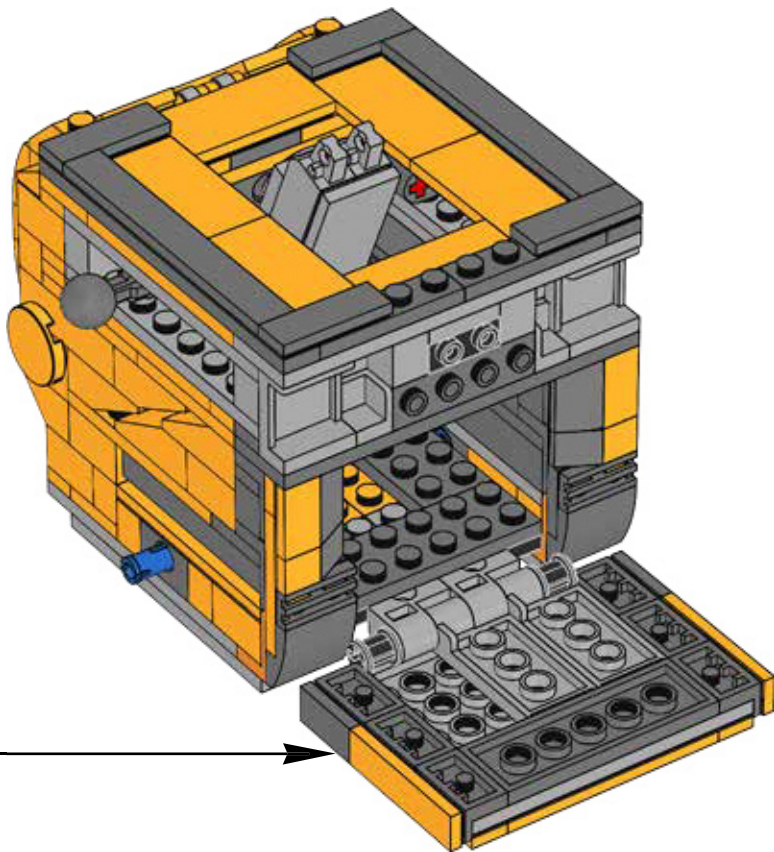
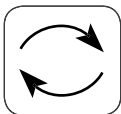



1x

64

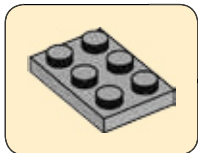
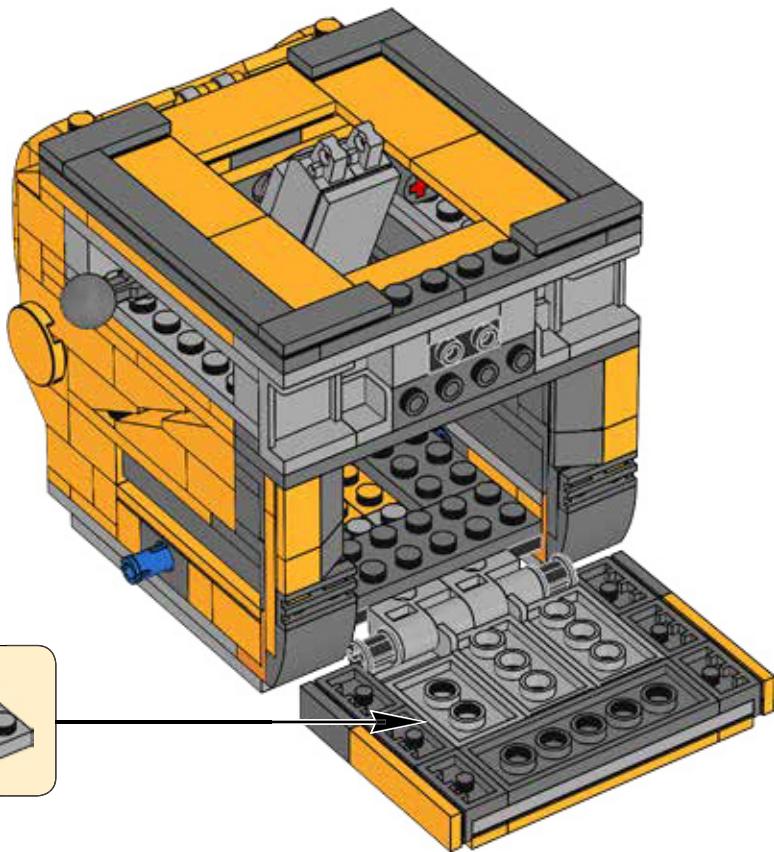



1x

65

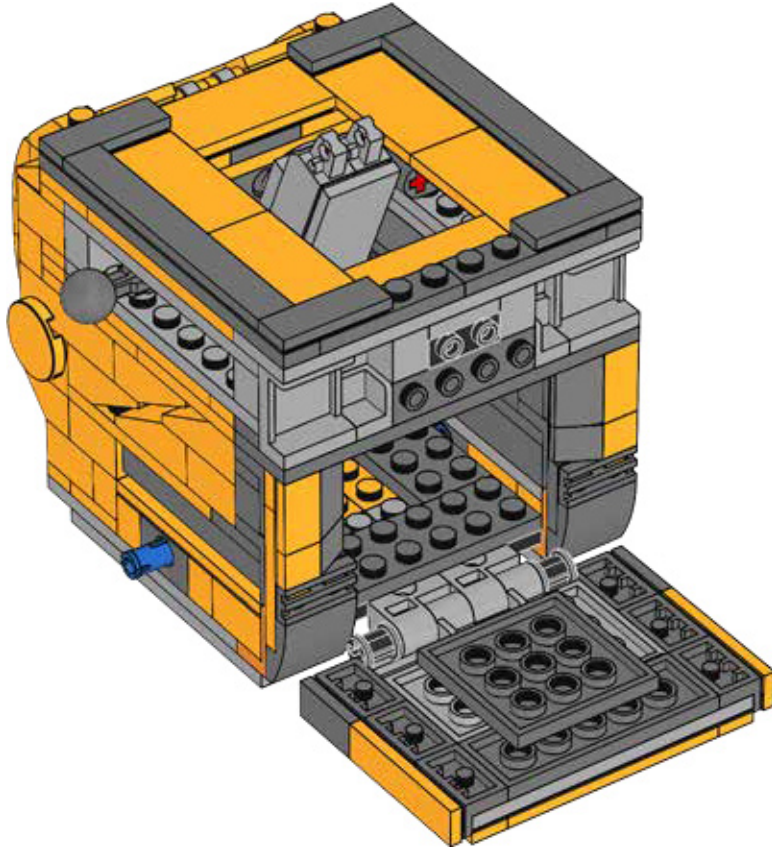



66

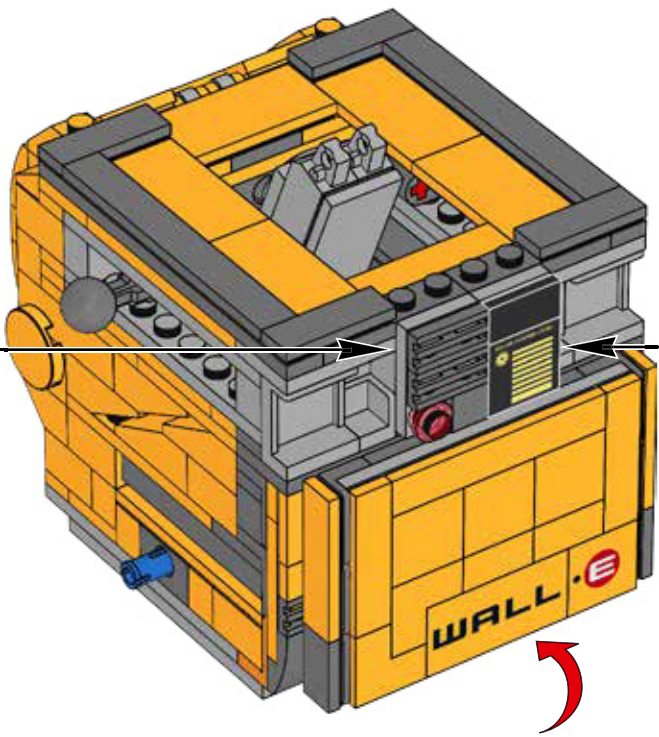
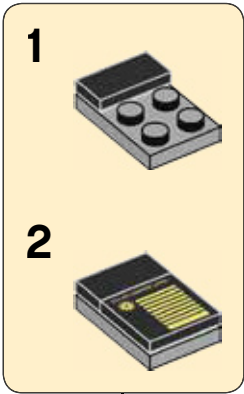
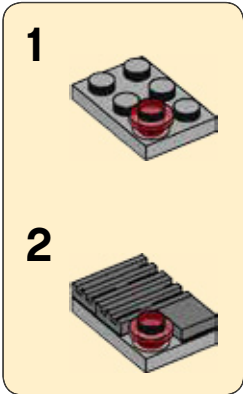



1x

67

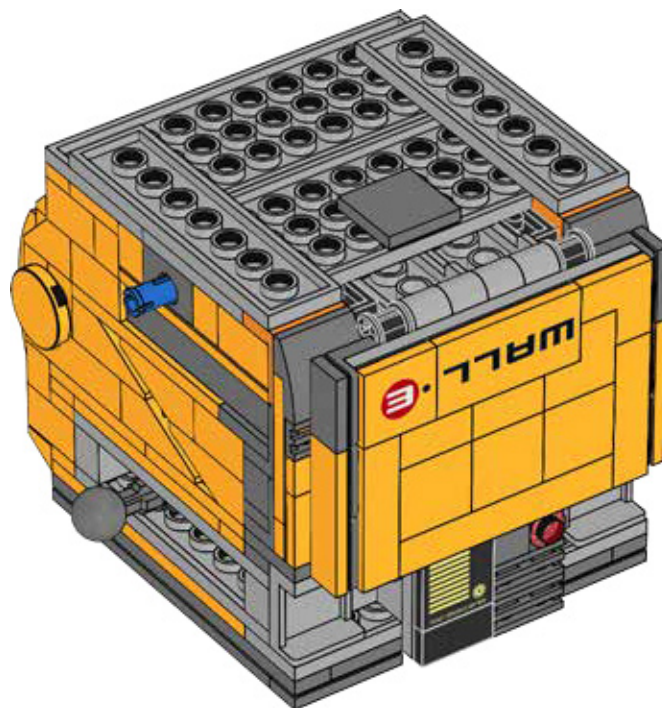
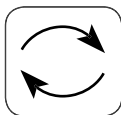

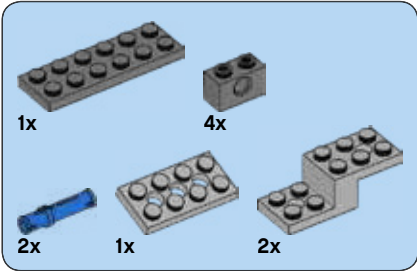

68

1

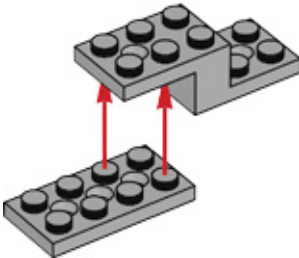

2

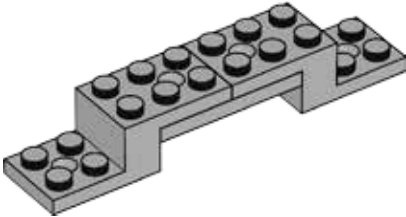

3

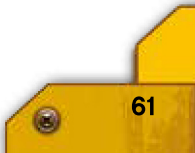
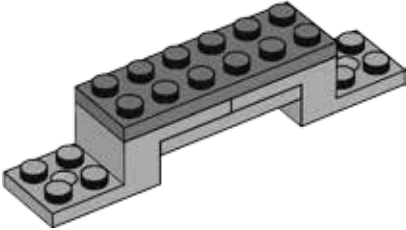

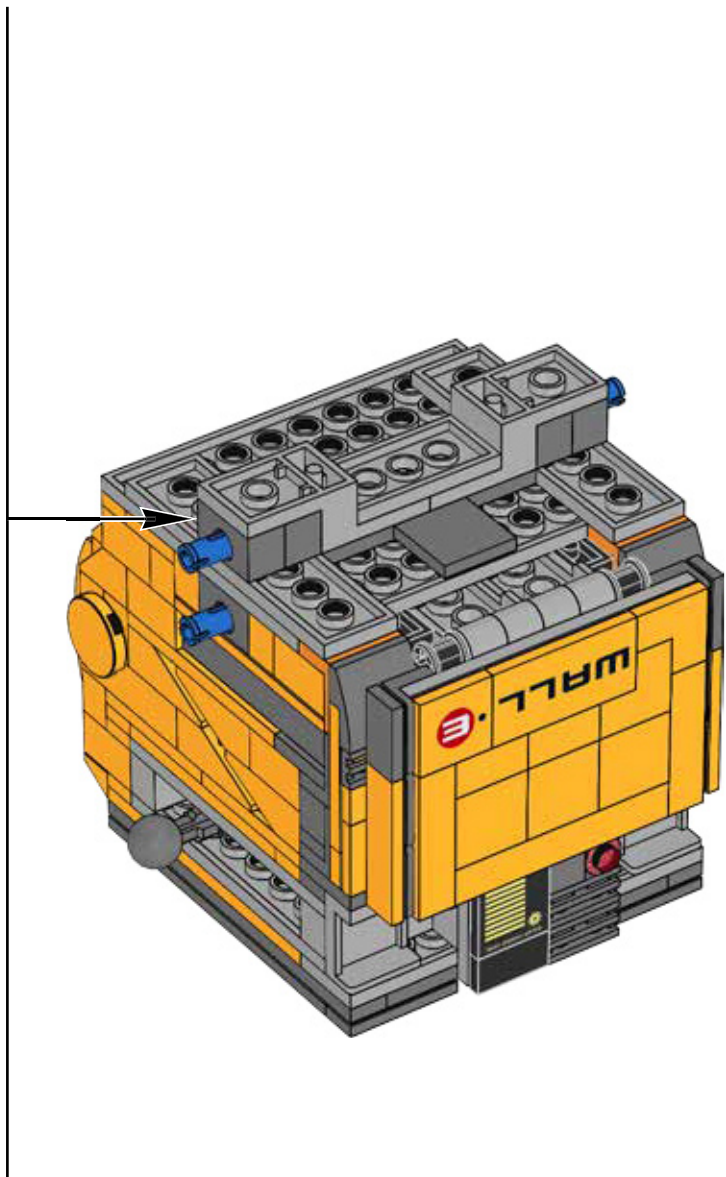
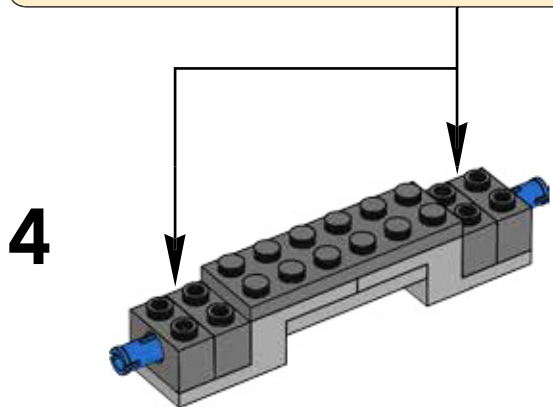
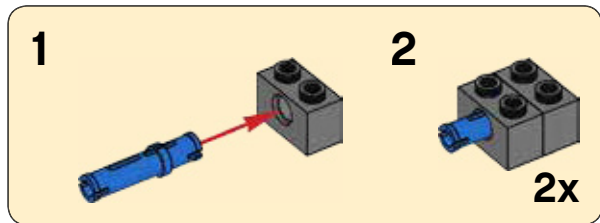

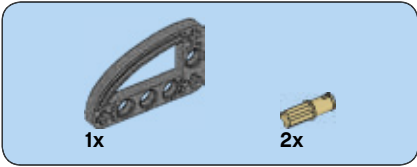
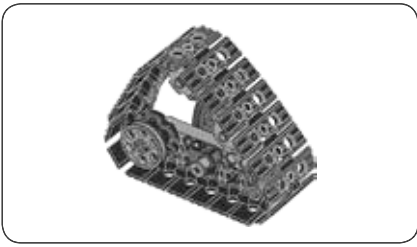

69

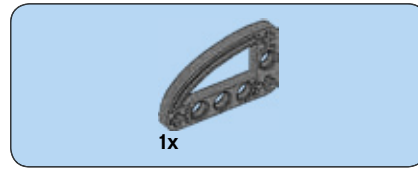
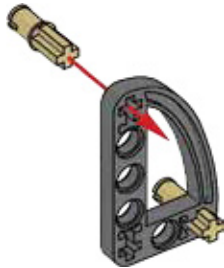

70

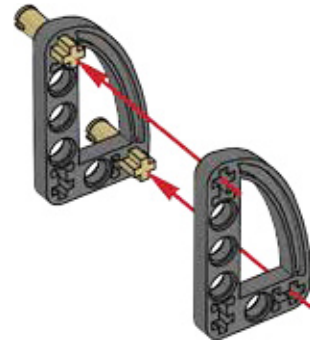

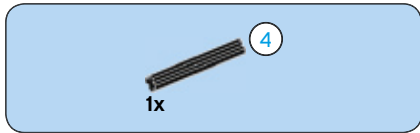

71

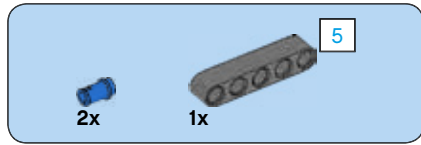
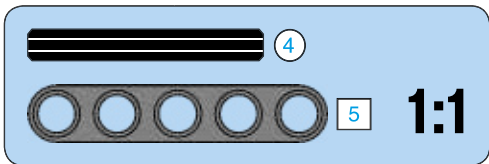
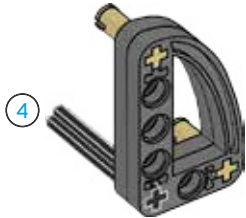

72

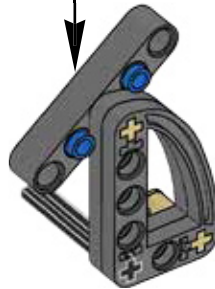
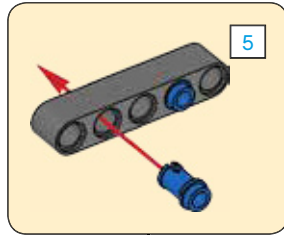



73

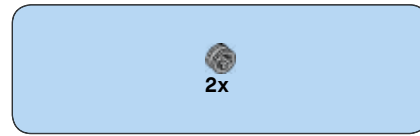
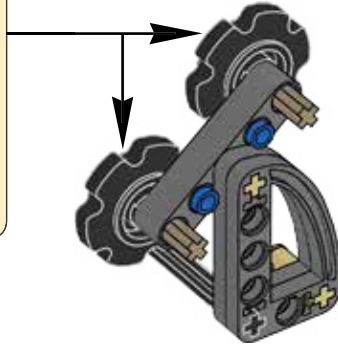
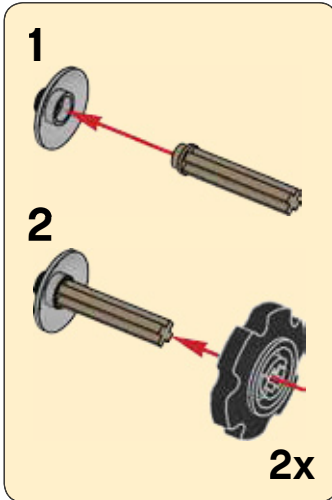

74

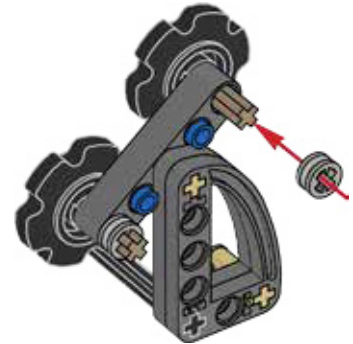

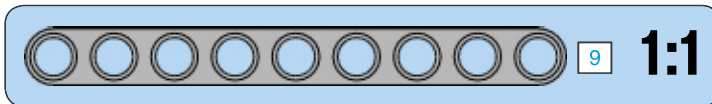
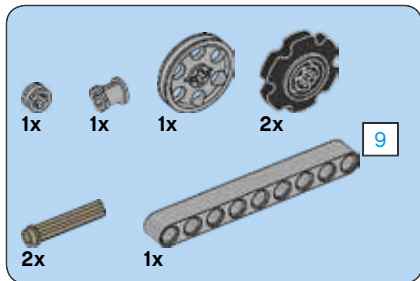

75

1

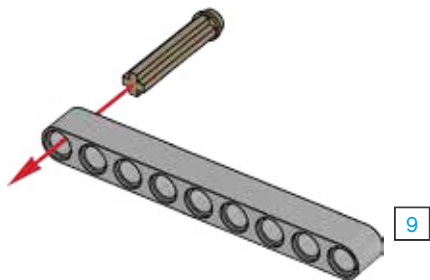

2

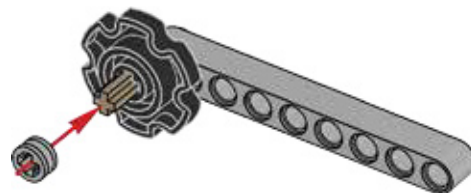

3

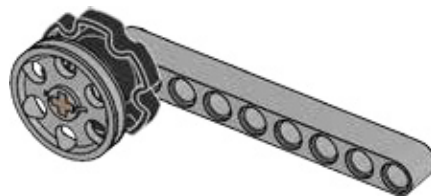

4

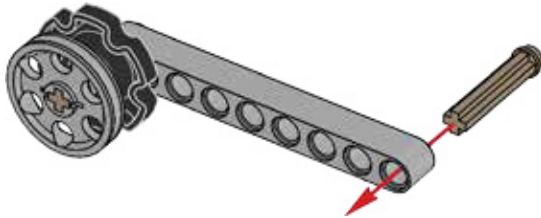

5

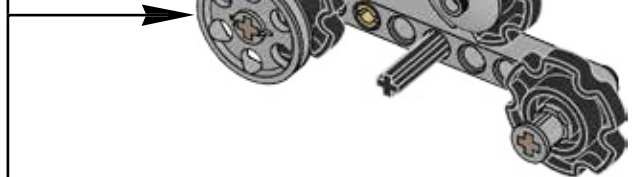
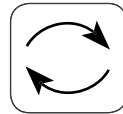
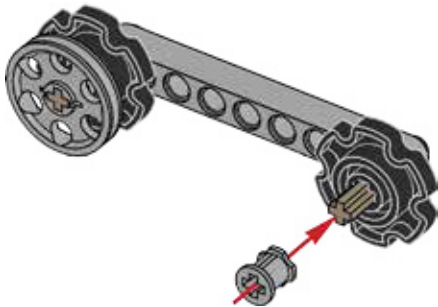



1x



1x



1x

76

1

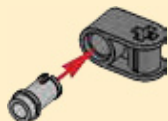

2

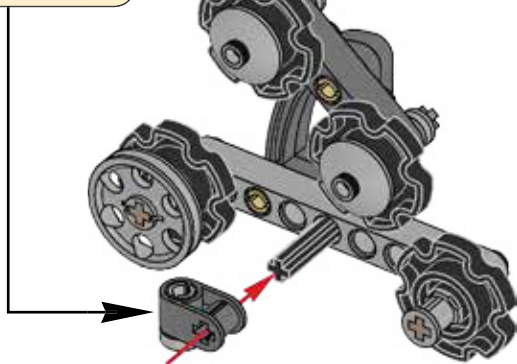

1x

77

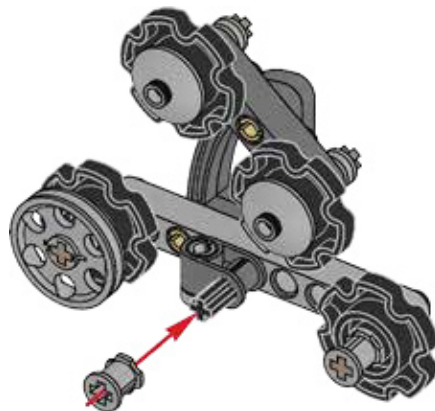



78

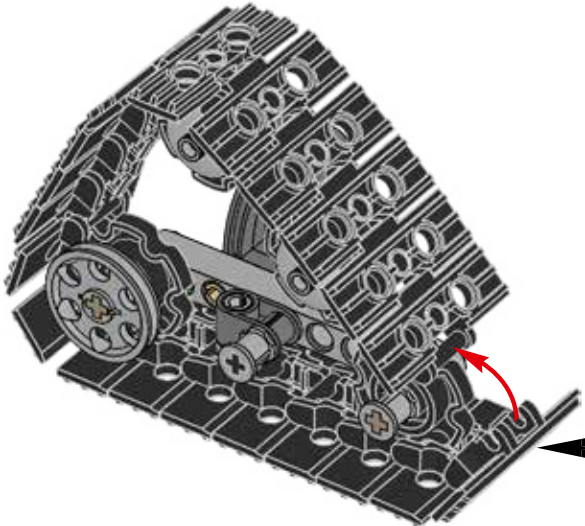
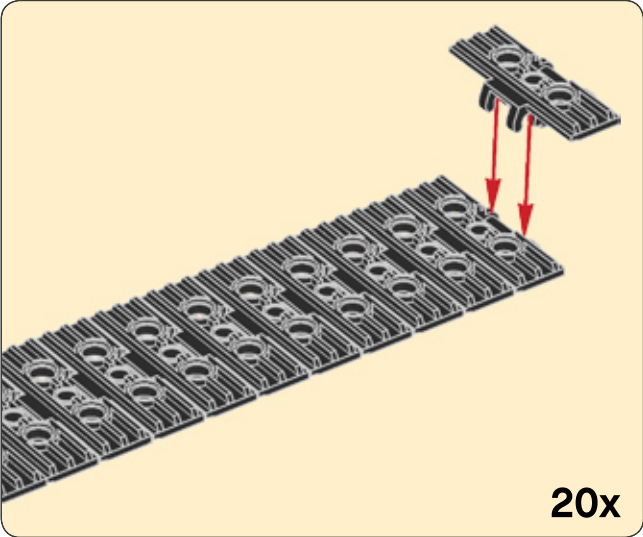

79

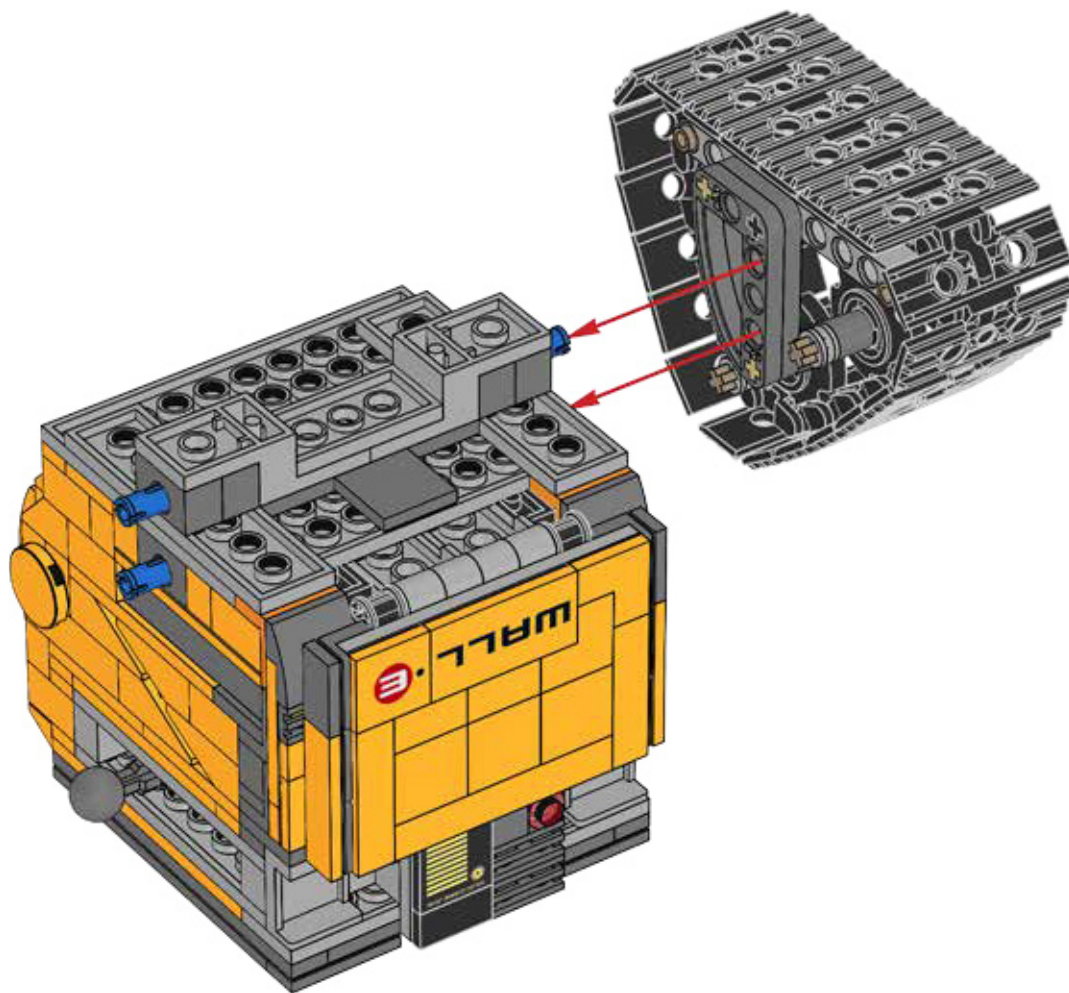

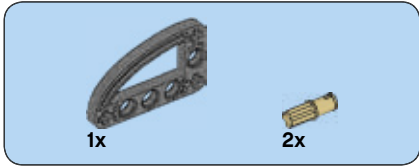
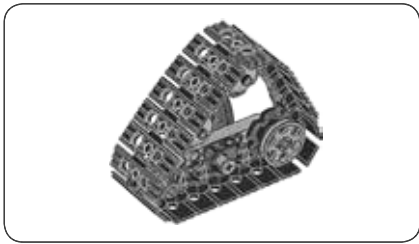

80

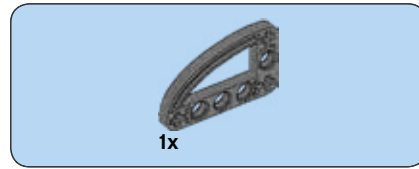
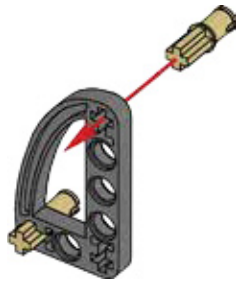

81

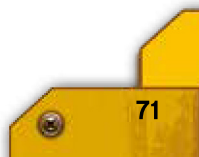
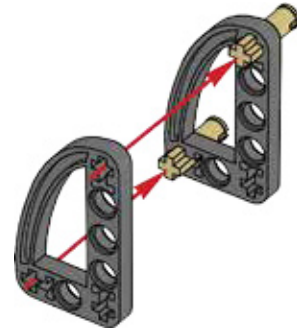

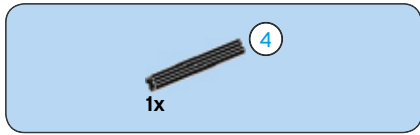

82

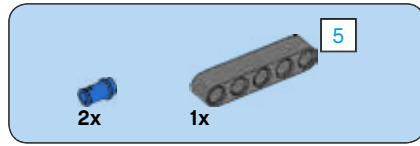
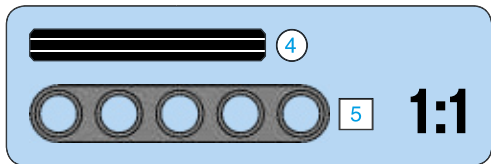
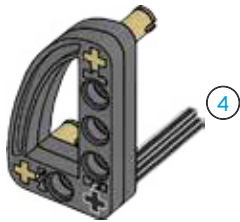

83

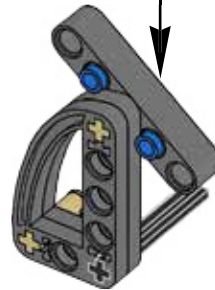
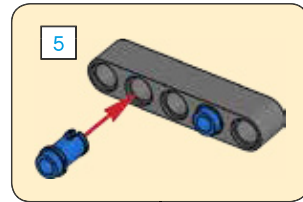



84

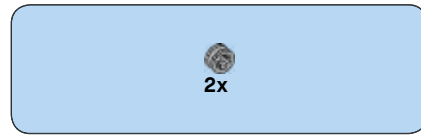
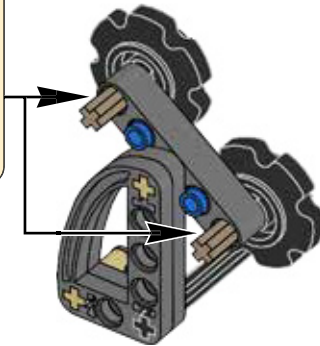
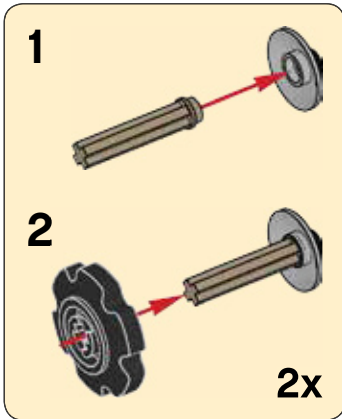

85

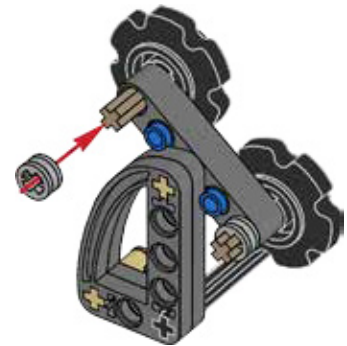

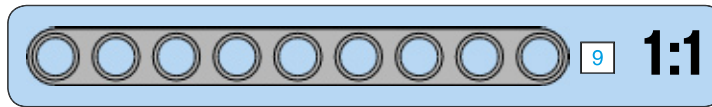
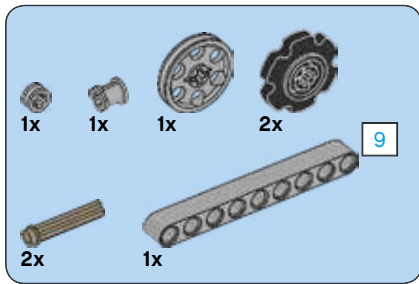

86

1

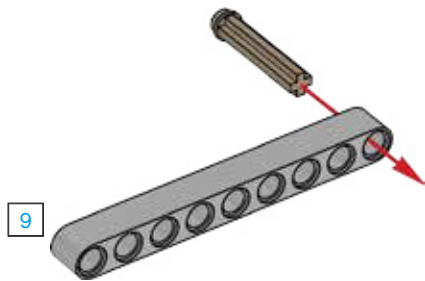

2

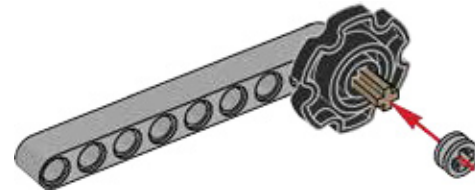

3

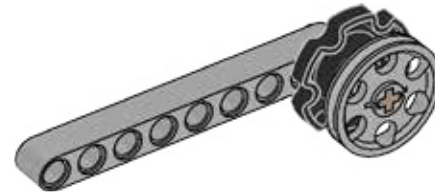

4

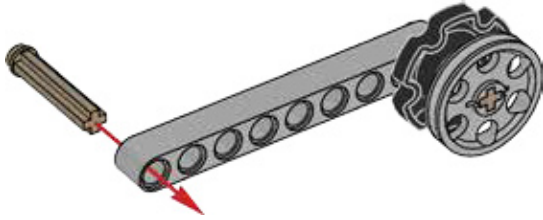

5

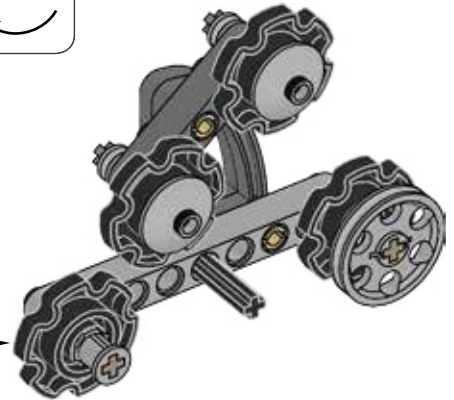
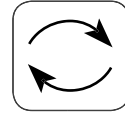
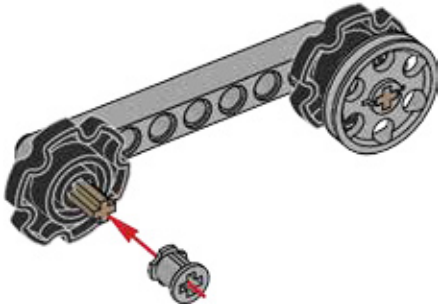



1x



1x



1x

87

1

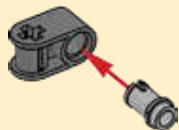

2

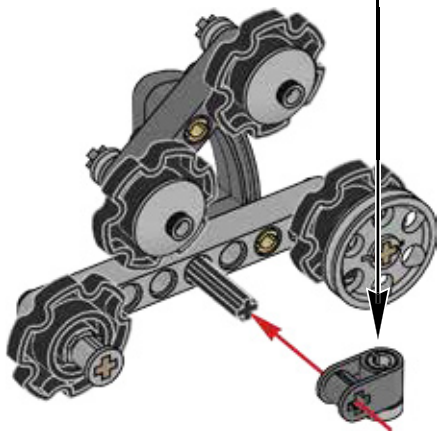

1x

88

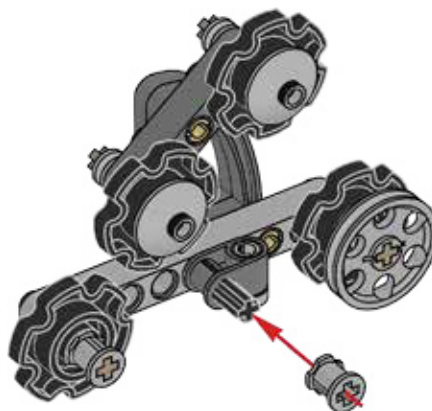



20x

89

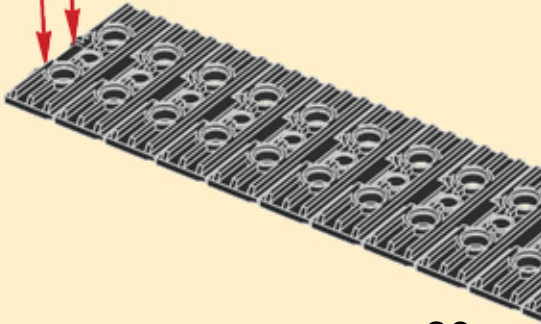

20x

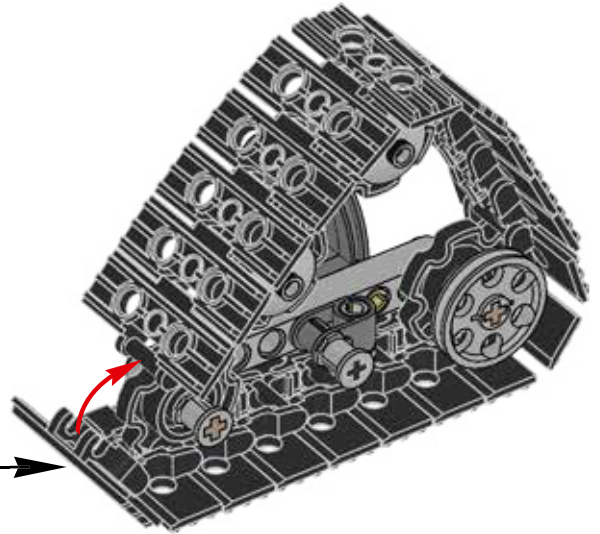

90

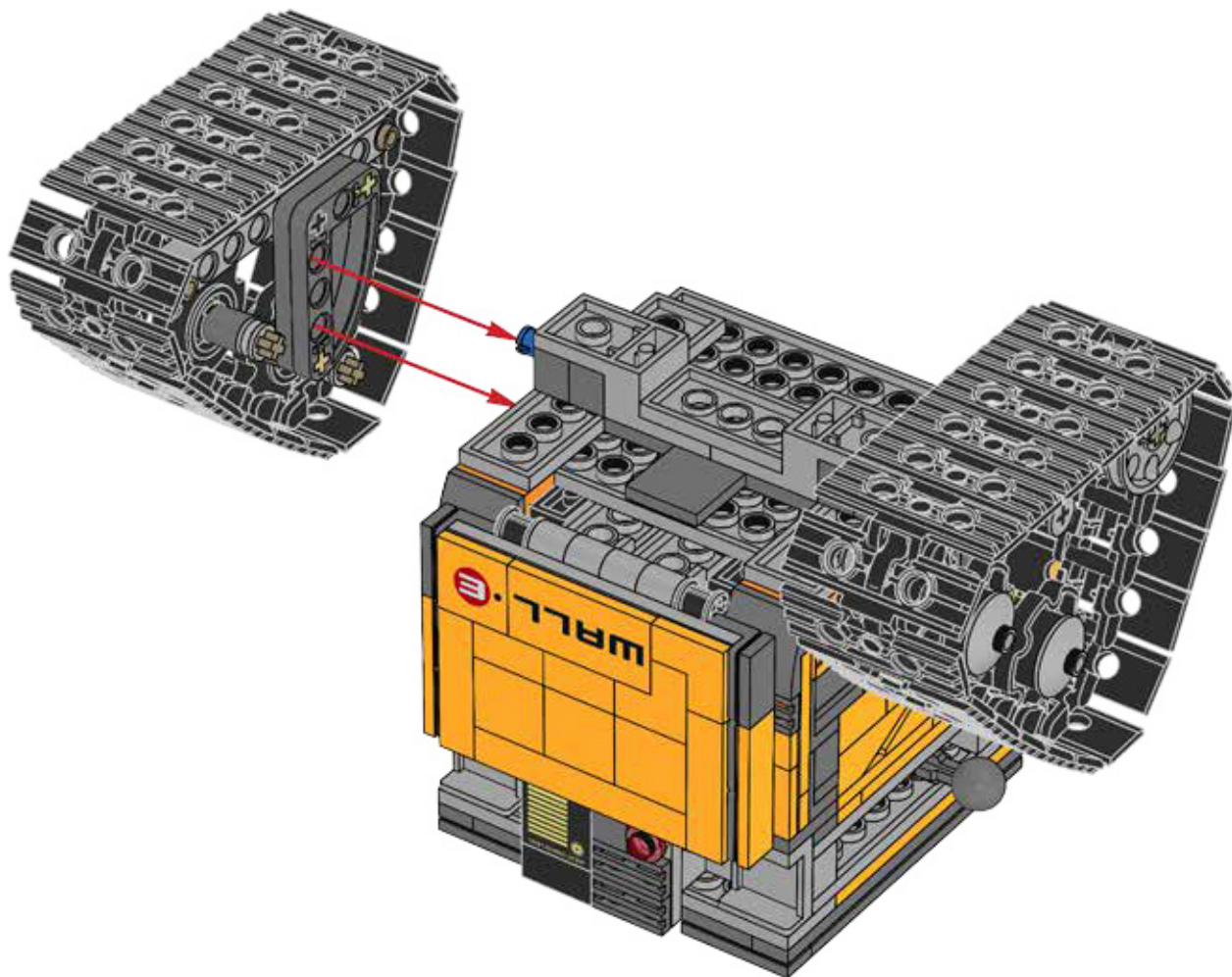



1x



1x

91

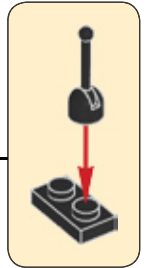
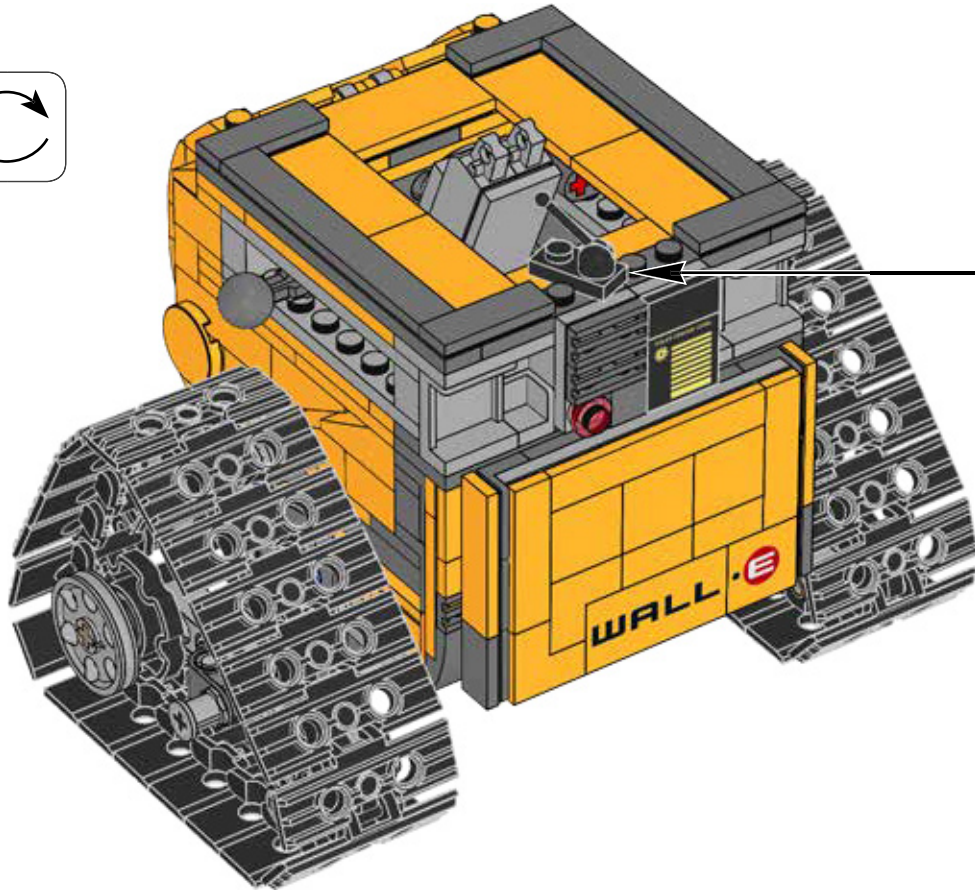
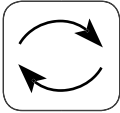



1x



1x

92

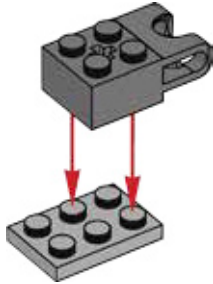

2x

93

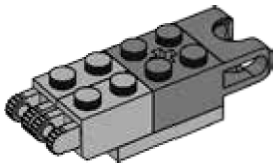

2x

94

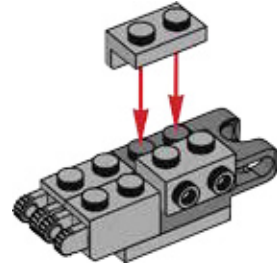

2x

95

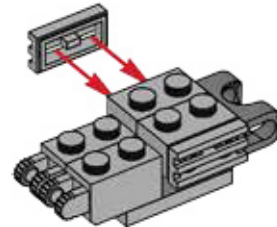



96

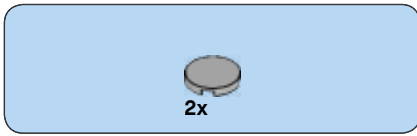
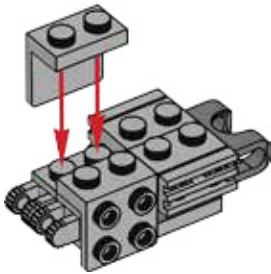

97

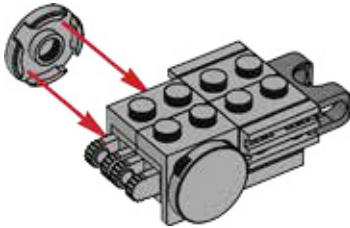



1x



2x

98

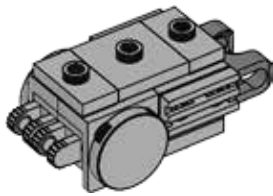

1x

99

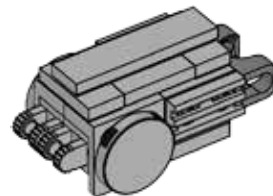

100

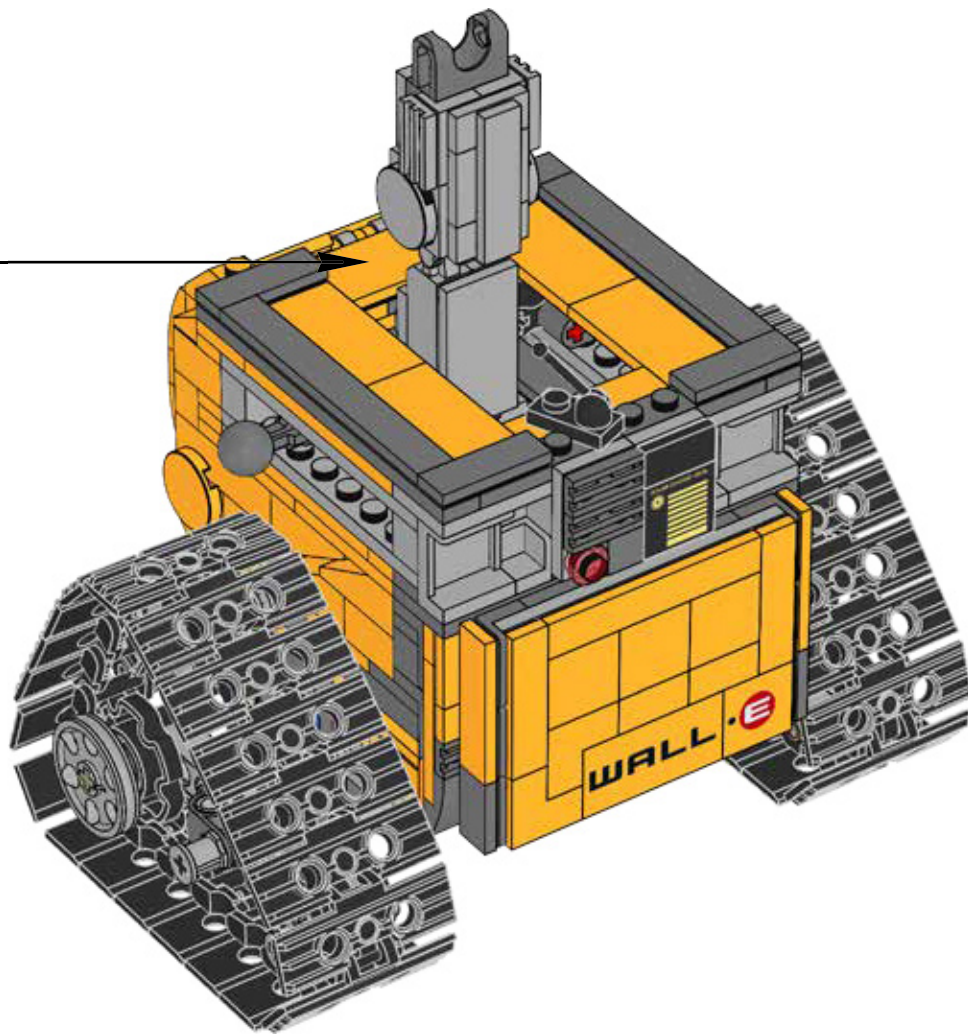

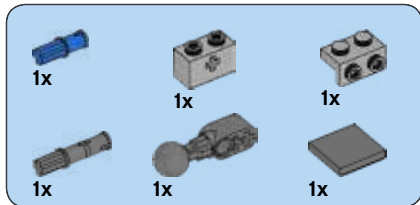

101

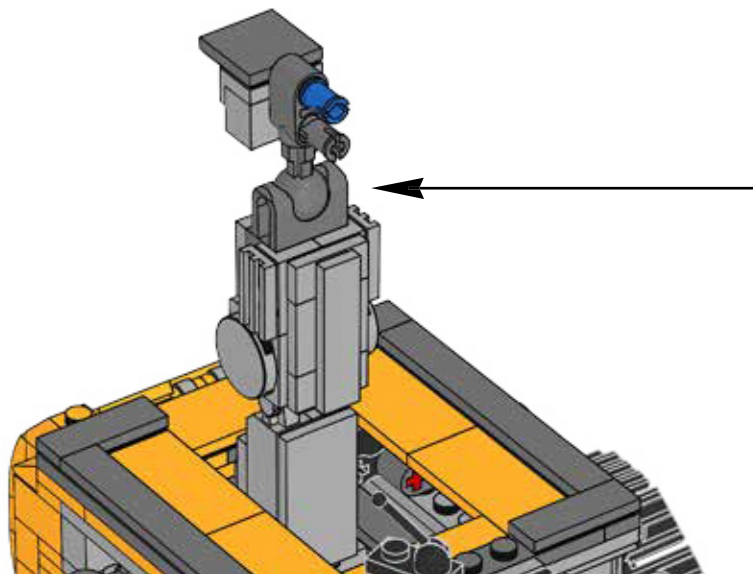
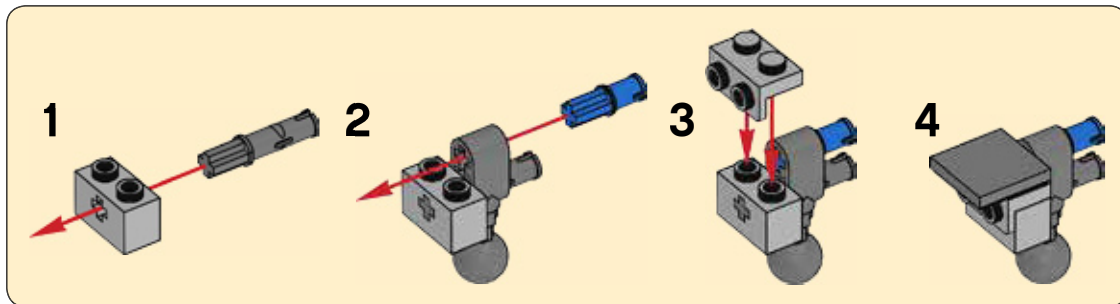

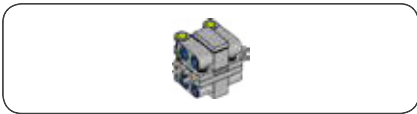

102

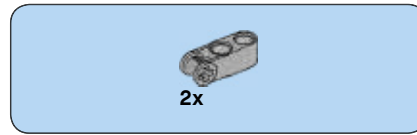
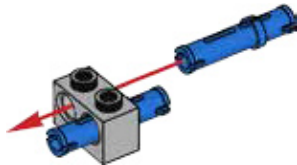

103

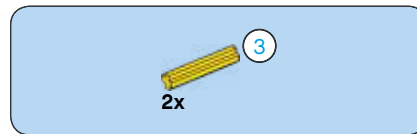
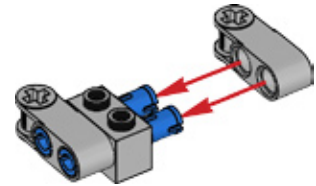

104

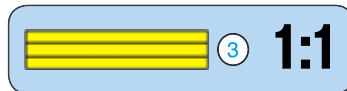
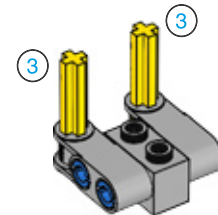

1:1



1x



1x

105

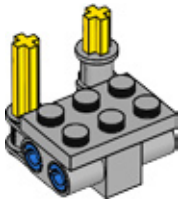

1x



1x



2x

106

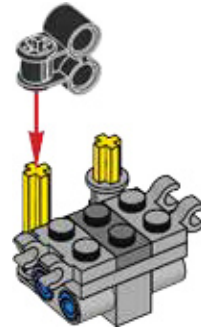

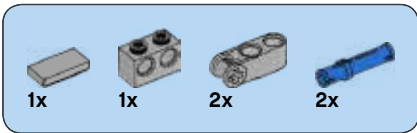

107

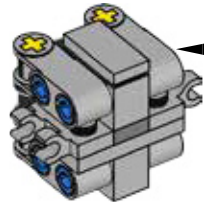
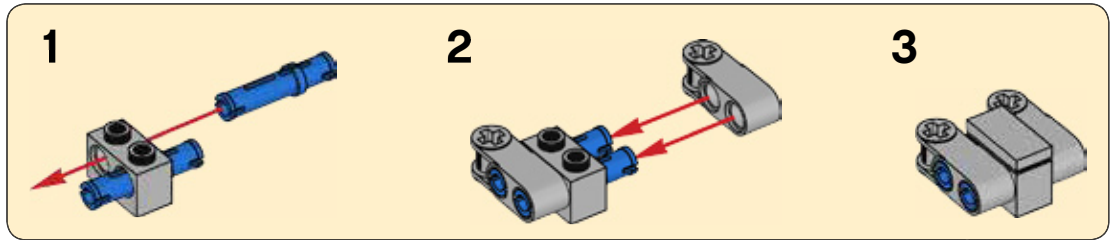

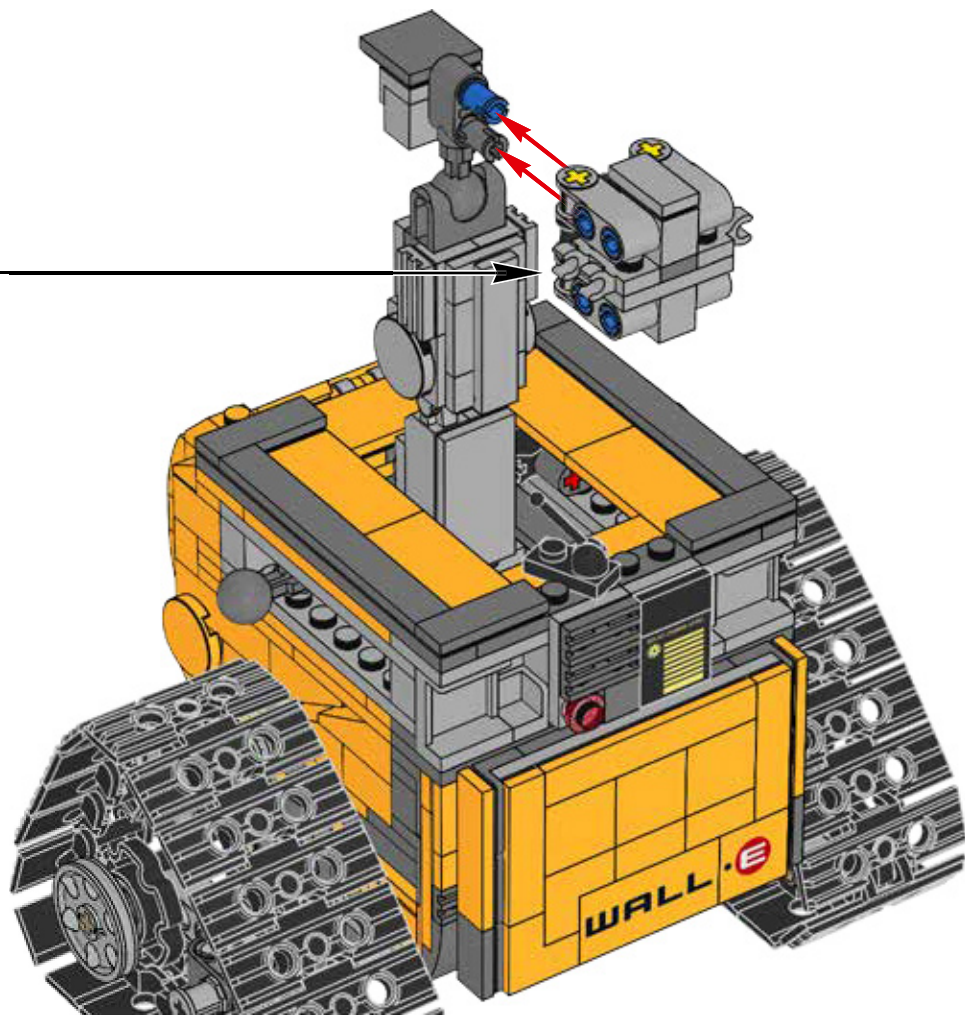

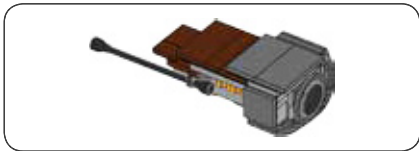

109

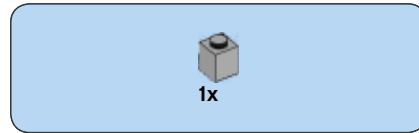
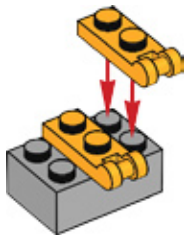

110

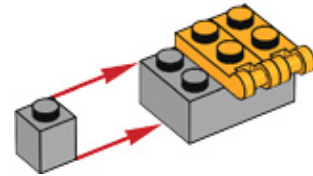

111

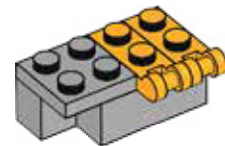



1x



1x

112

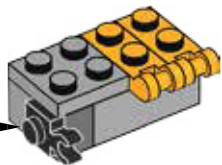
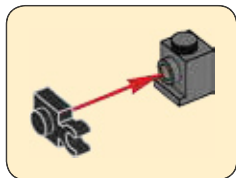

1x



1x



1x

113

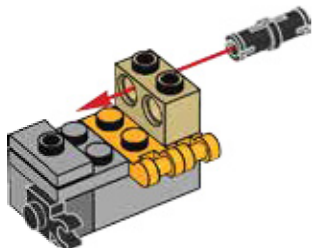

1x



1x

114

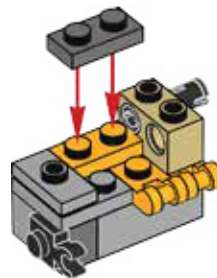

1x



1x

115

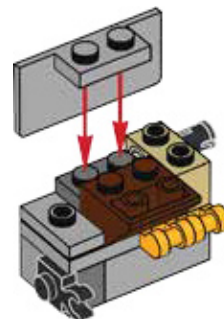

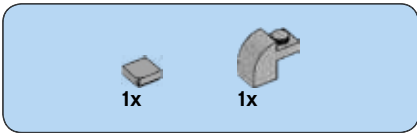

116

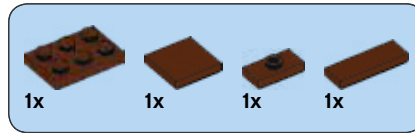
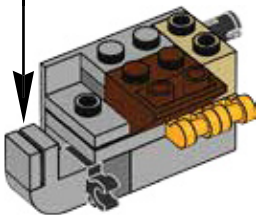
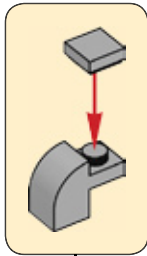

117

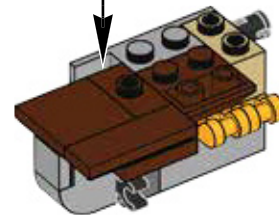

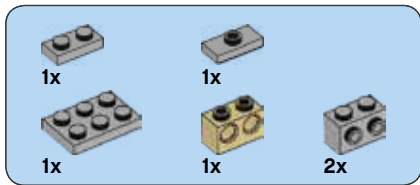

118

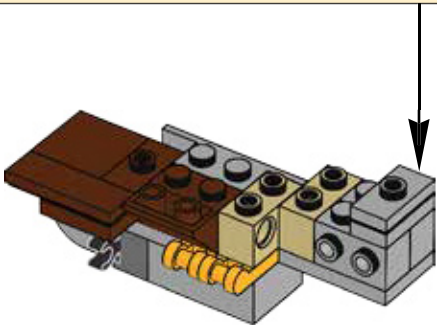
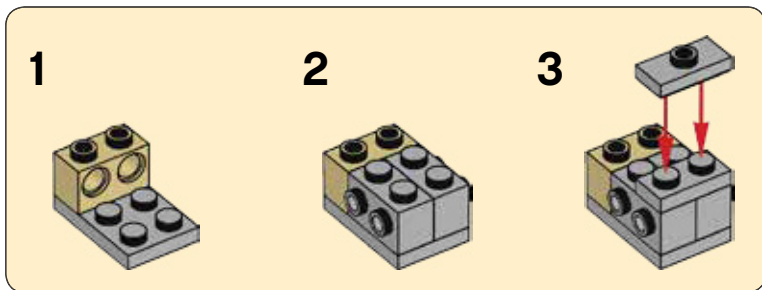

119

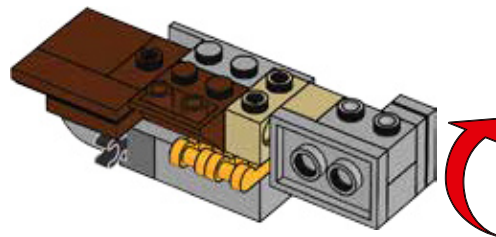



120

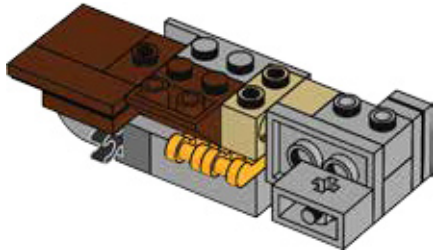

121

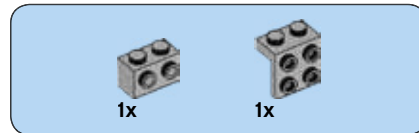
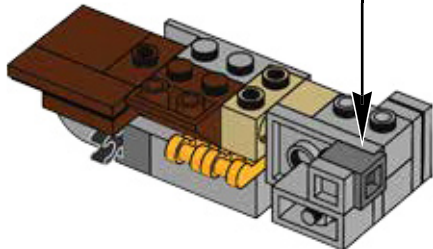

122

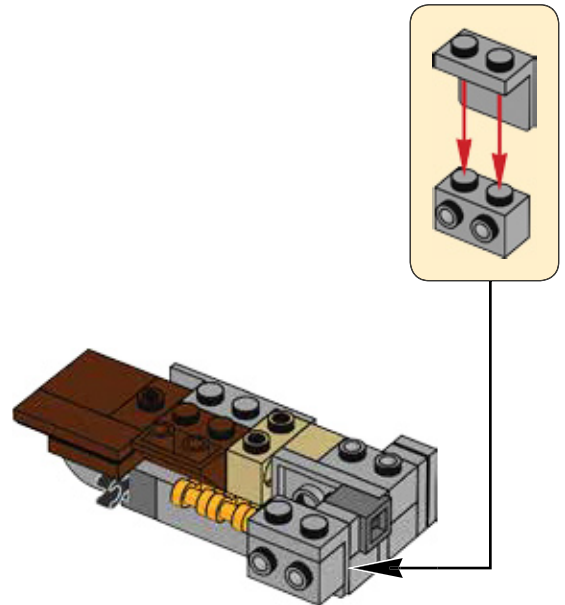

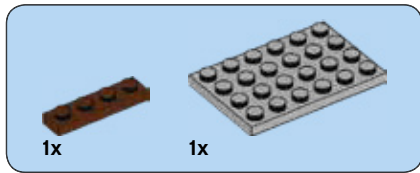

123

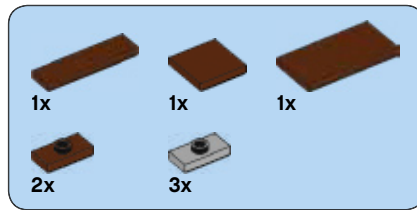
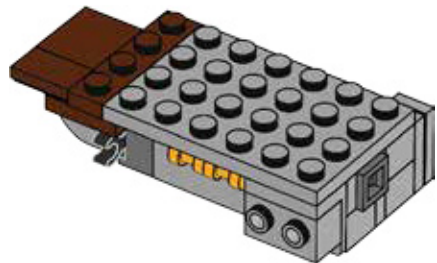

124

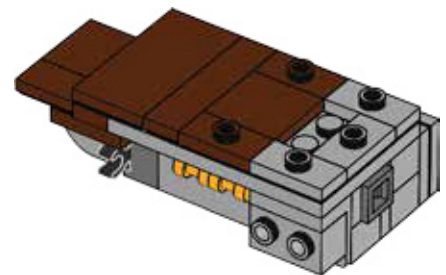

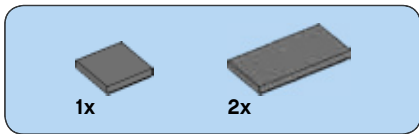

125

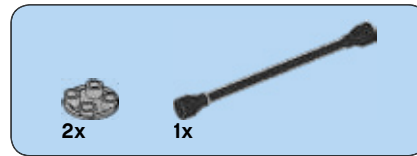
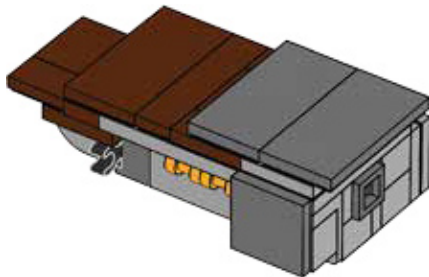

126

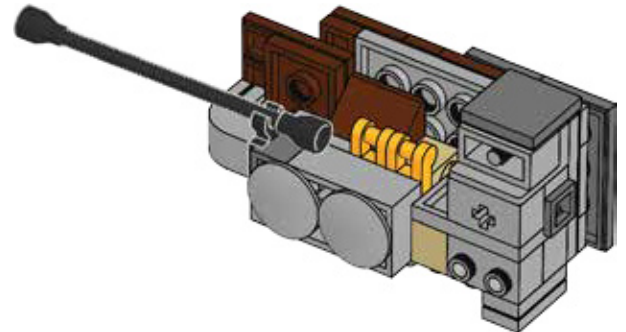
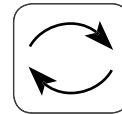

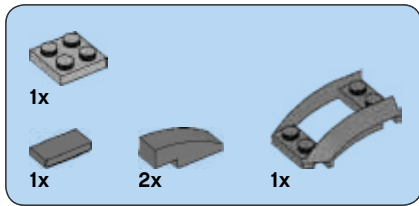

127

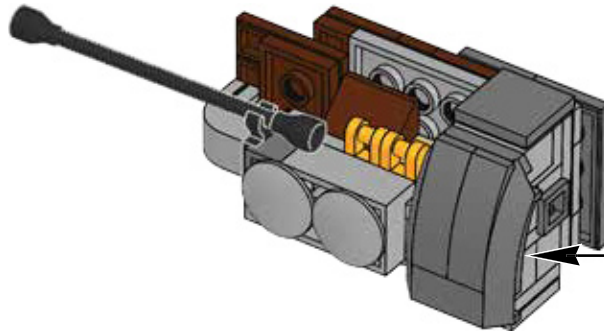
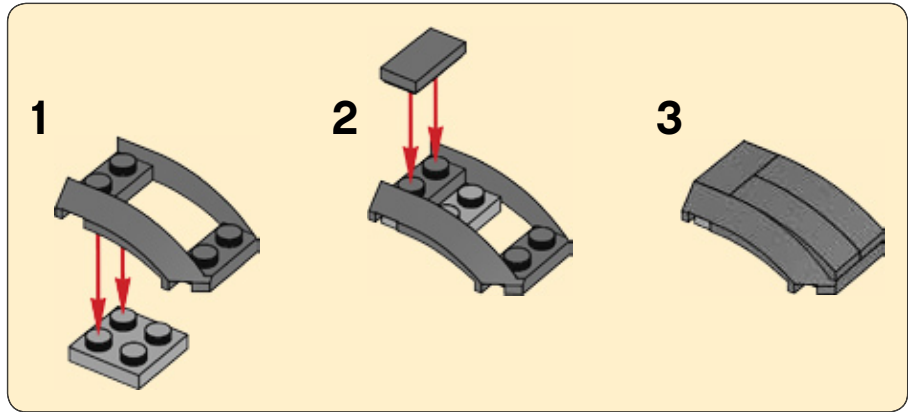

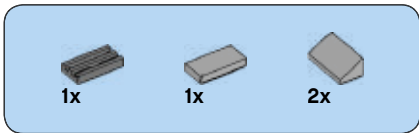

128

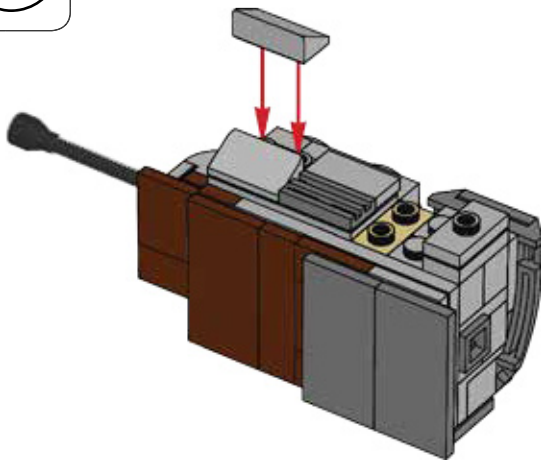
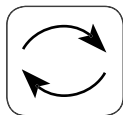

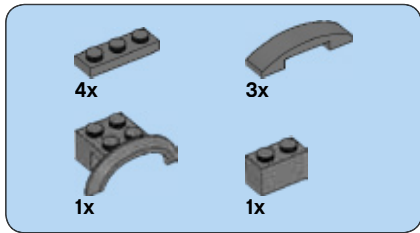

129

1

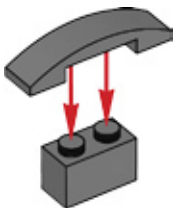

2

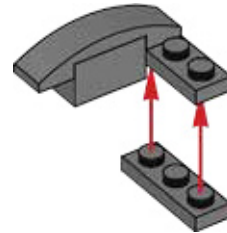

3

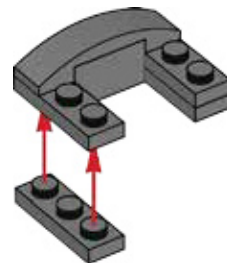

4

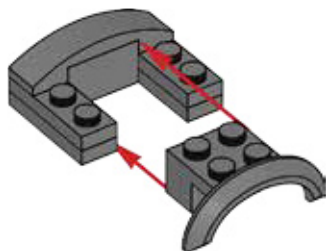

5

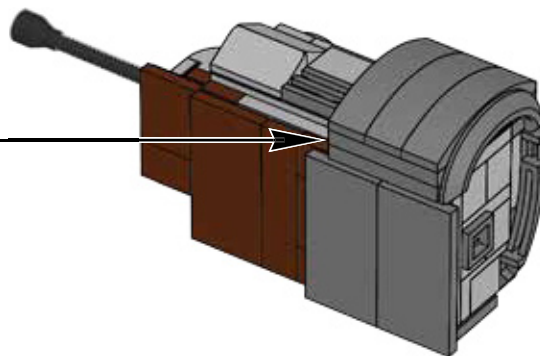
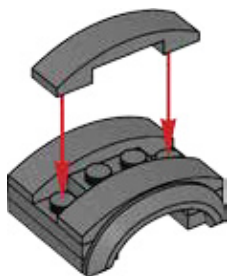

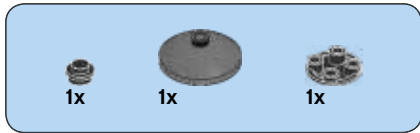

130

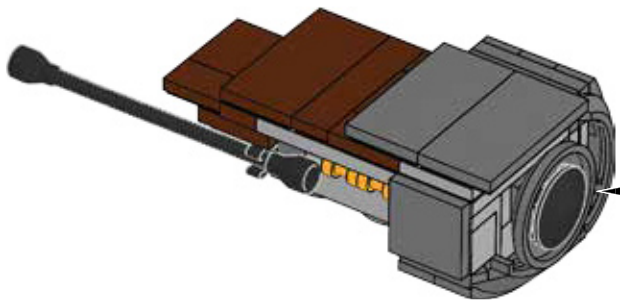
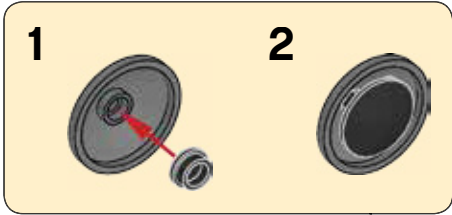
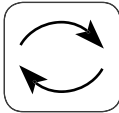

131

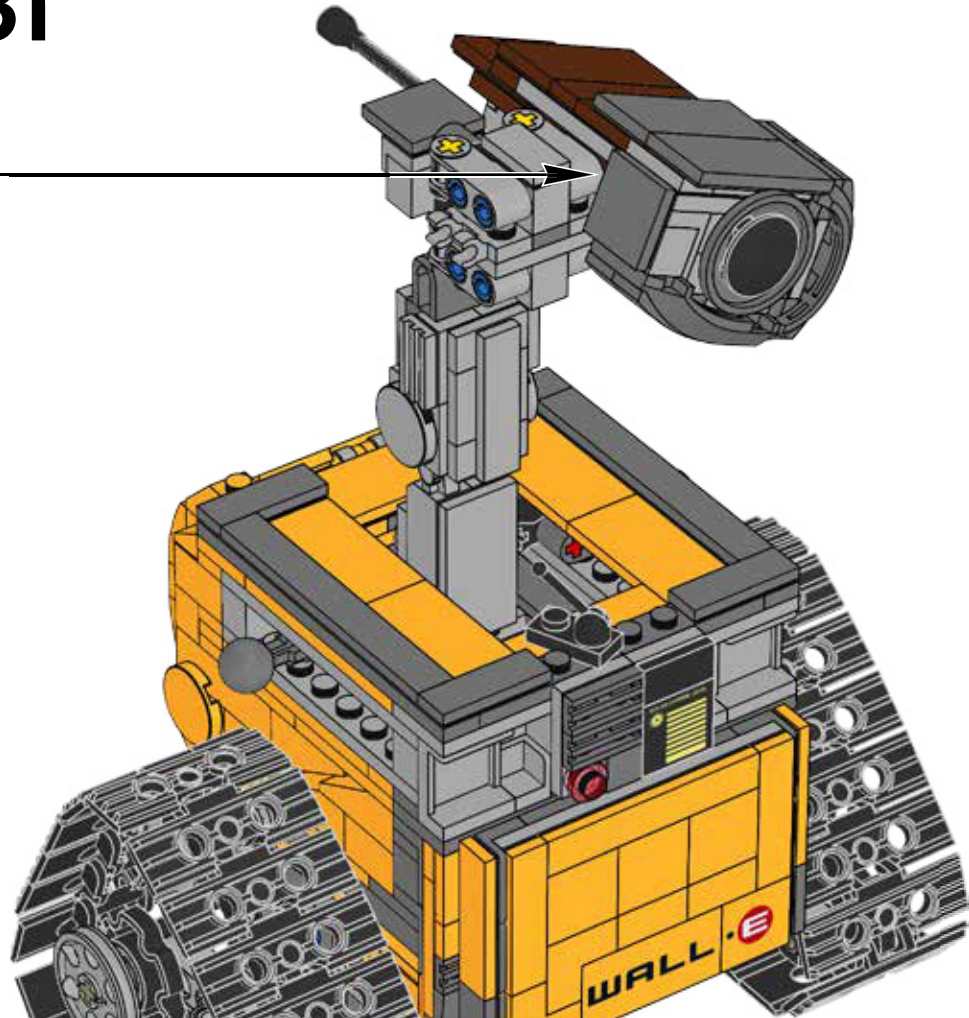



132

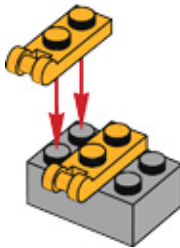

133

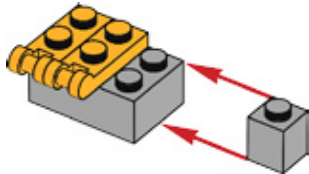

134

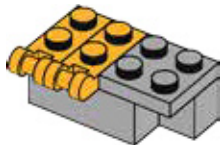



1x



1x

135

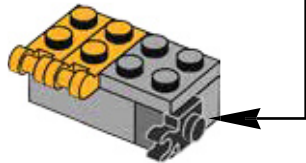
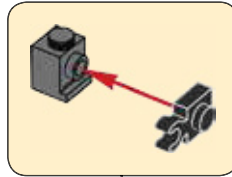

1x



1x

137

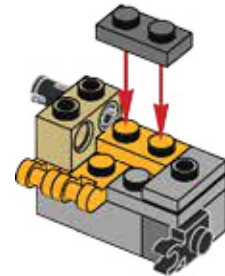

1x



1x



1x

136

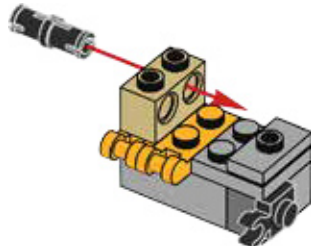

1x



1x

138

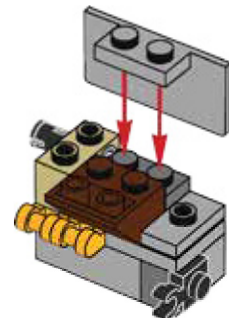

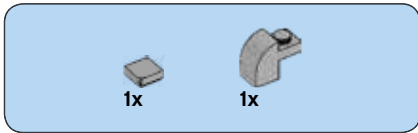

139

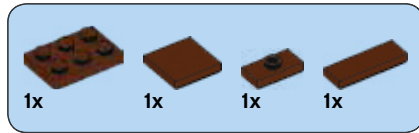
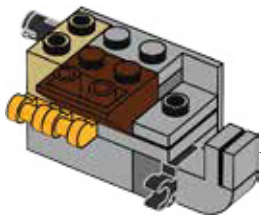
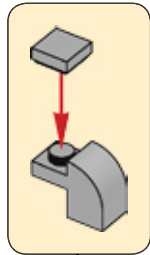

140

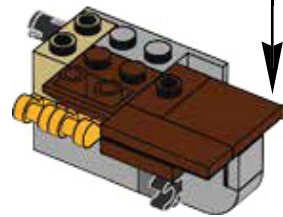

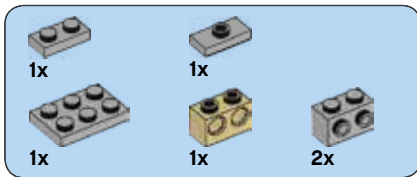

141

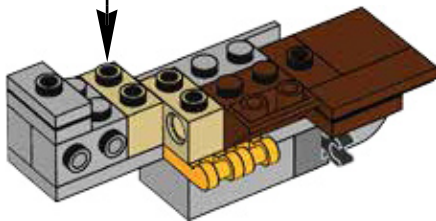
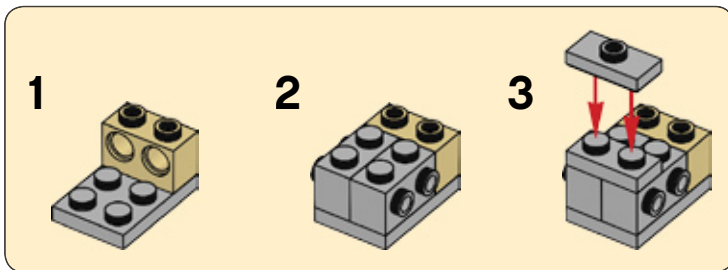

142

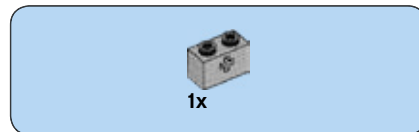
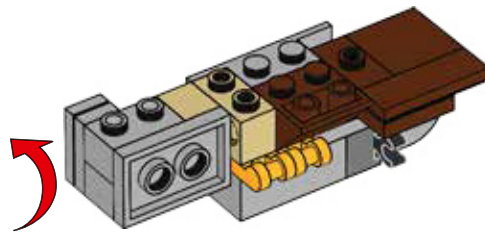

143

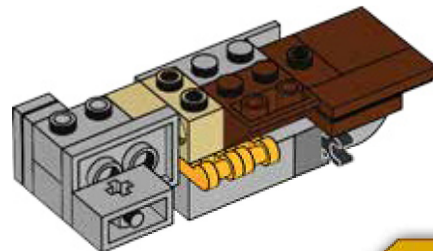



1x



1x

144

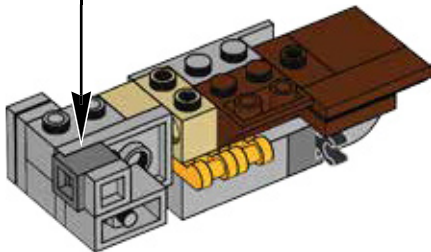
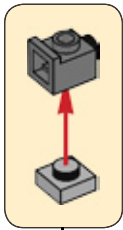

1x



1x

145

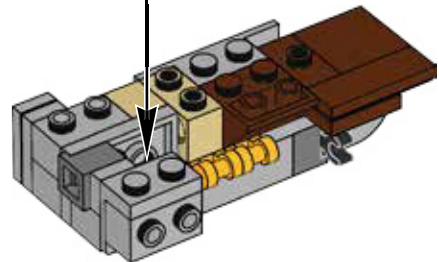
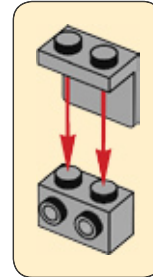

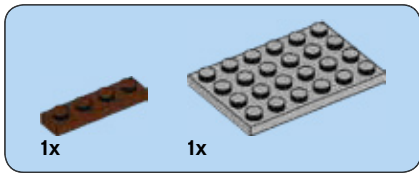

146

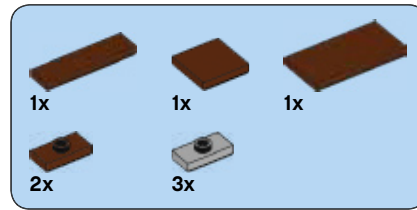
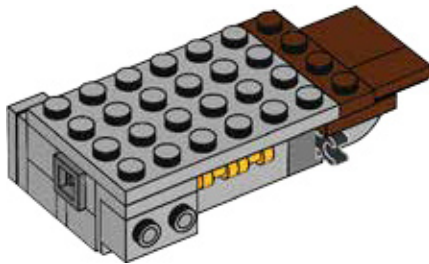

147

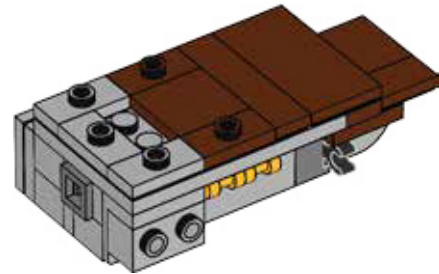

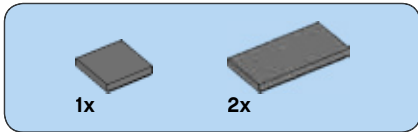

148

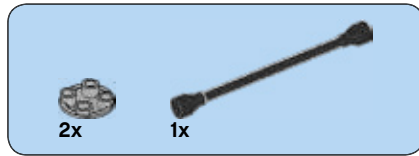
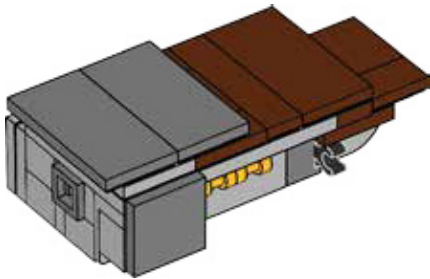

149

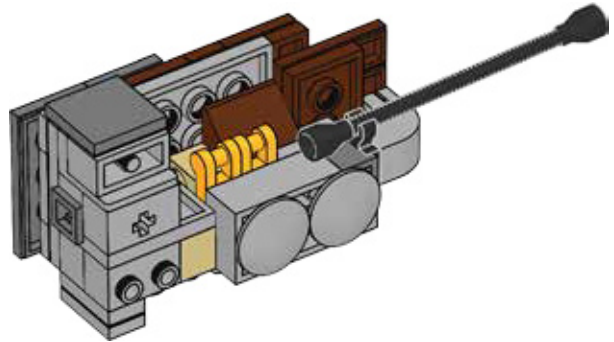
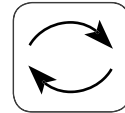

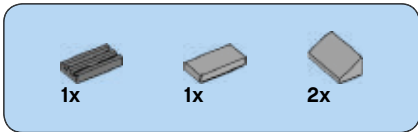

151

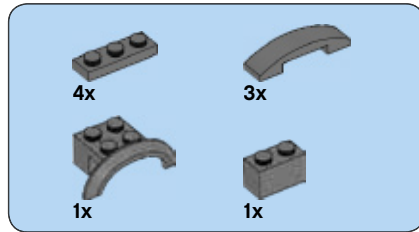
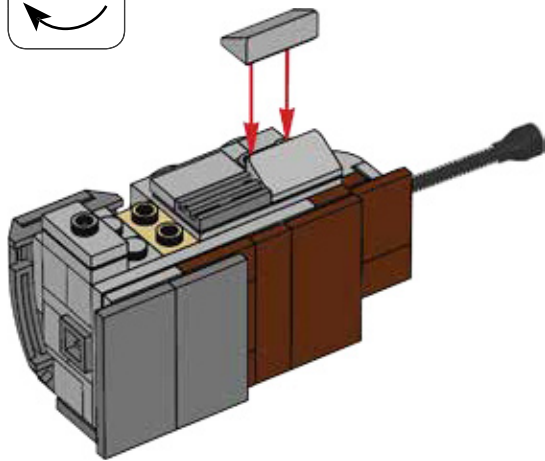
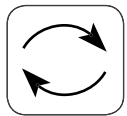

152

1

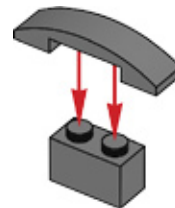

2

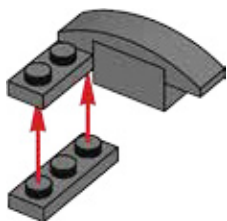

3

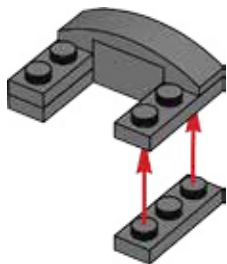

4

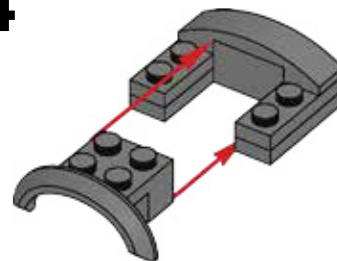

5

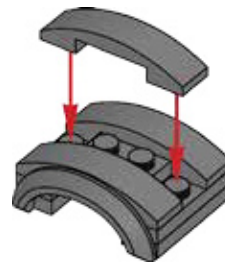

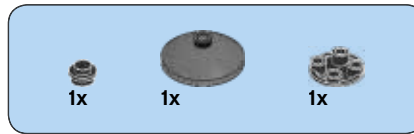
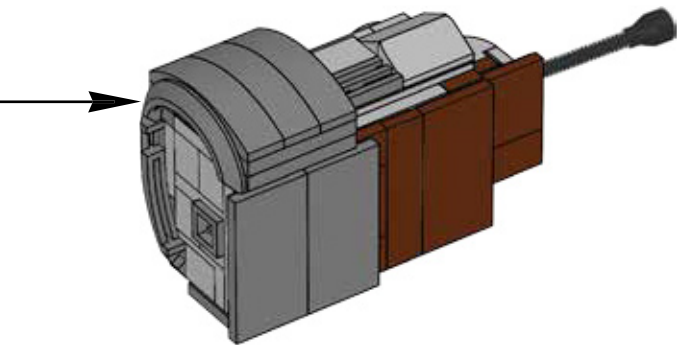

153

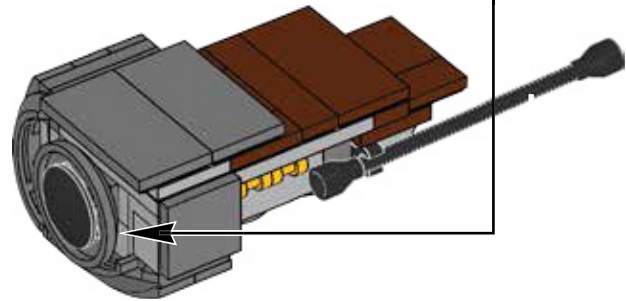
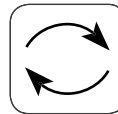
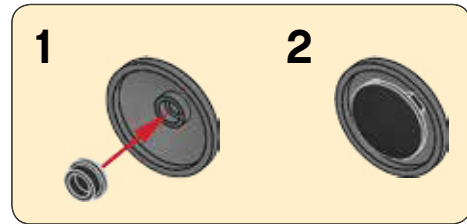

154

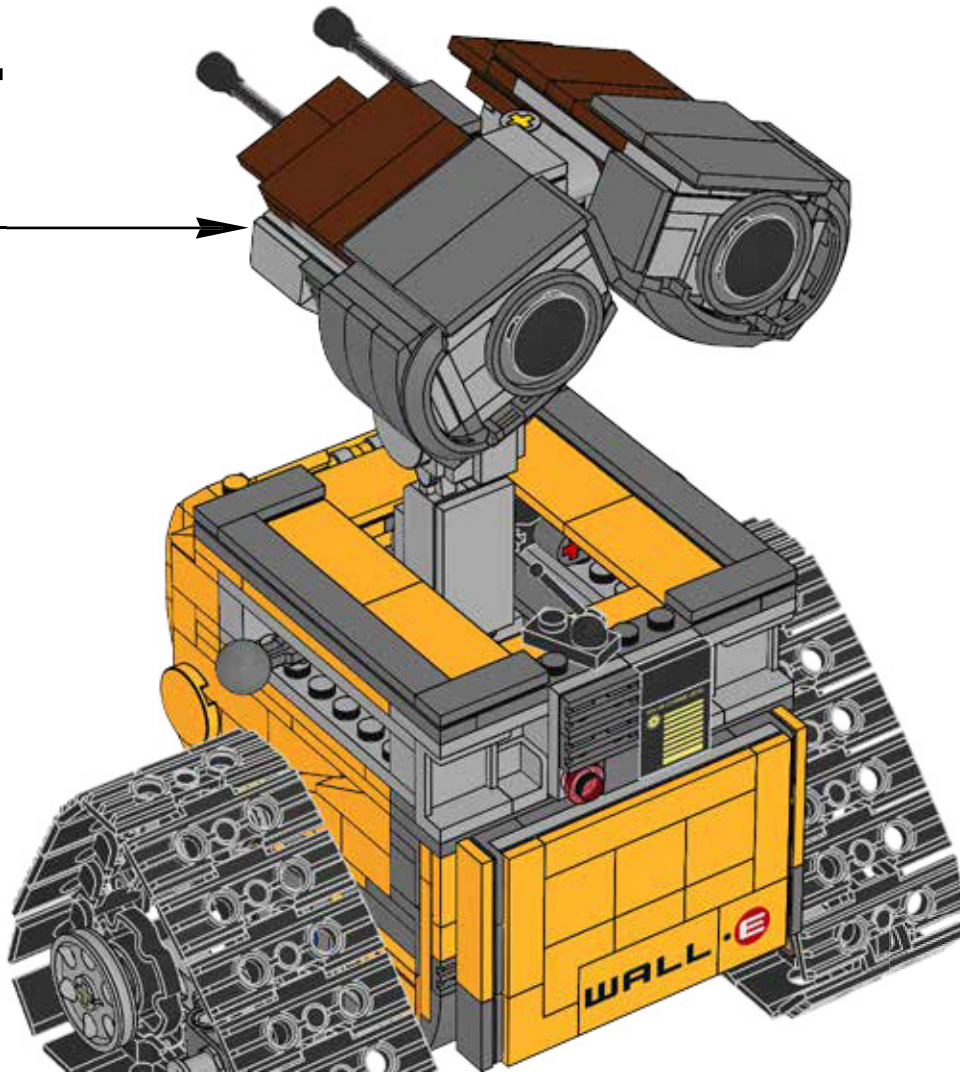

155

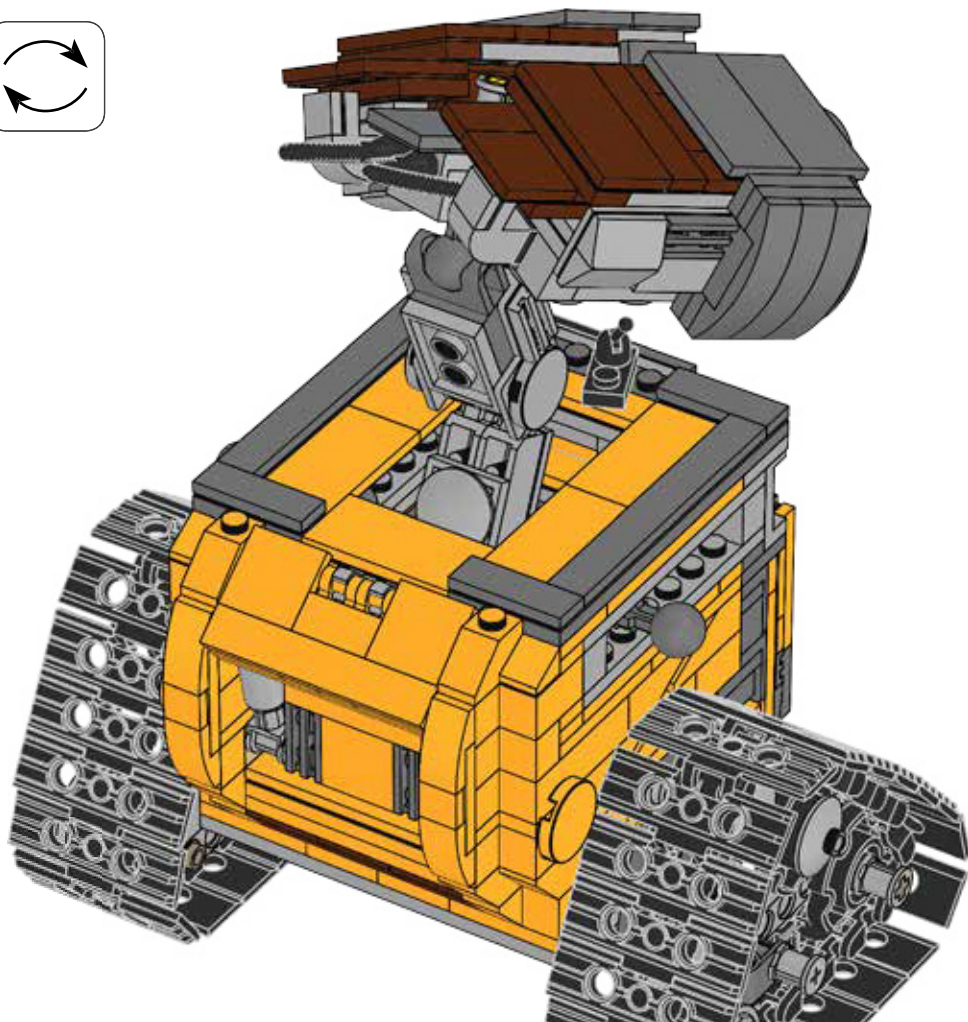
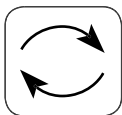

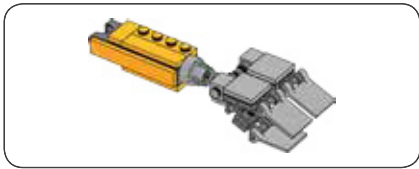

156

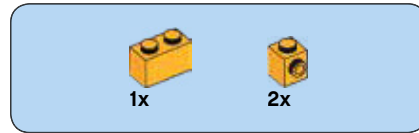

157

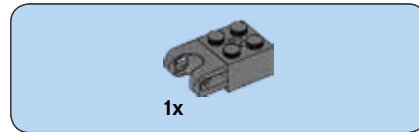
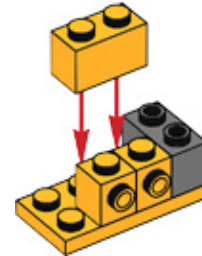

158

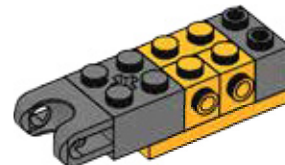



159

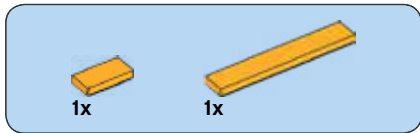
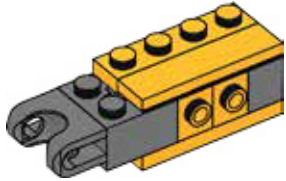

160

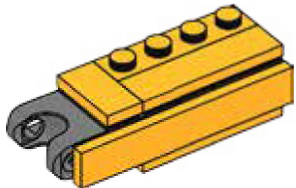

161

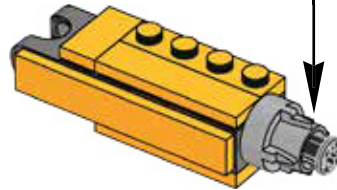
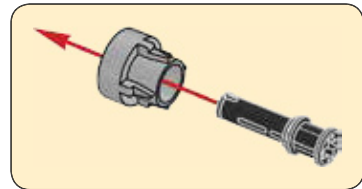



162

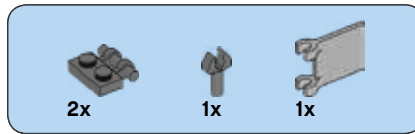
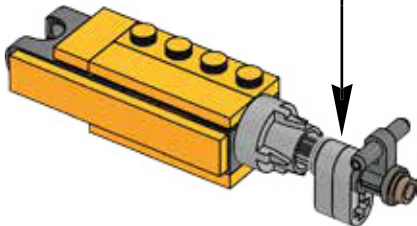
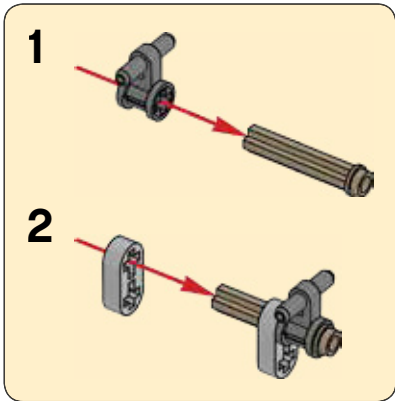

163

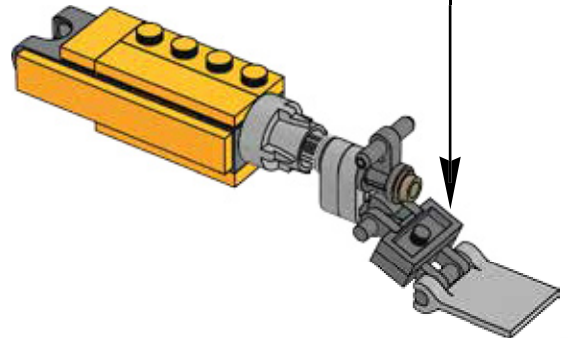
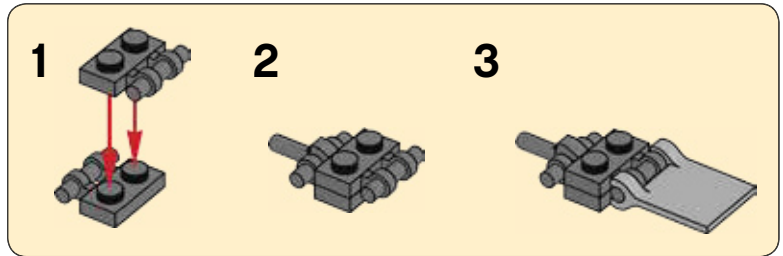

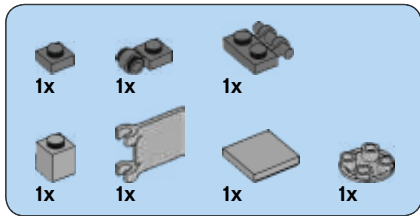

164

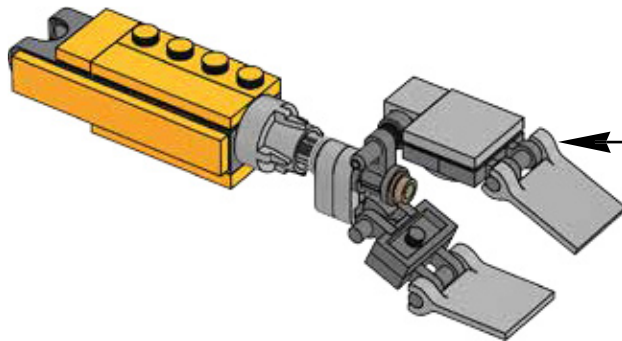
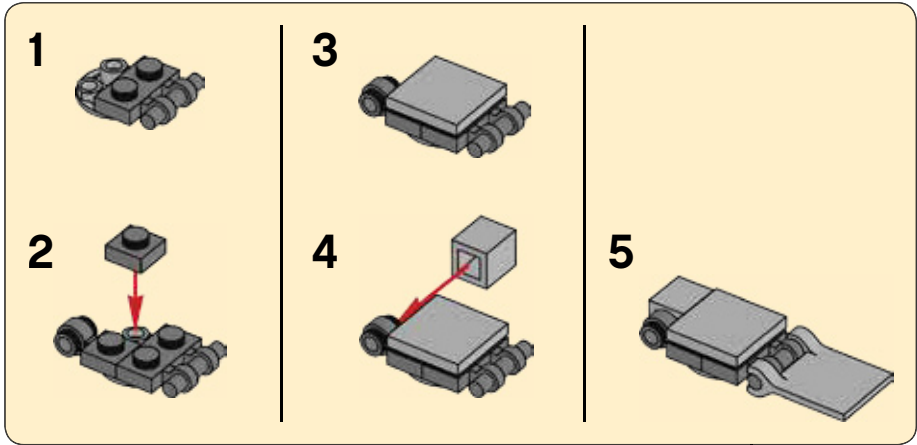

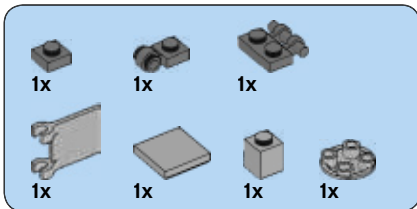

165

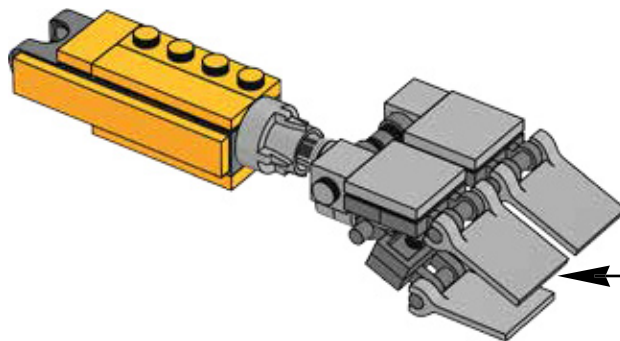
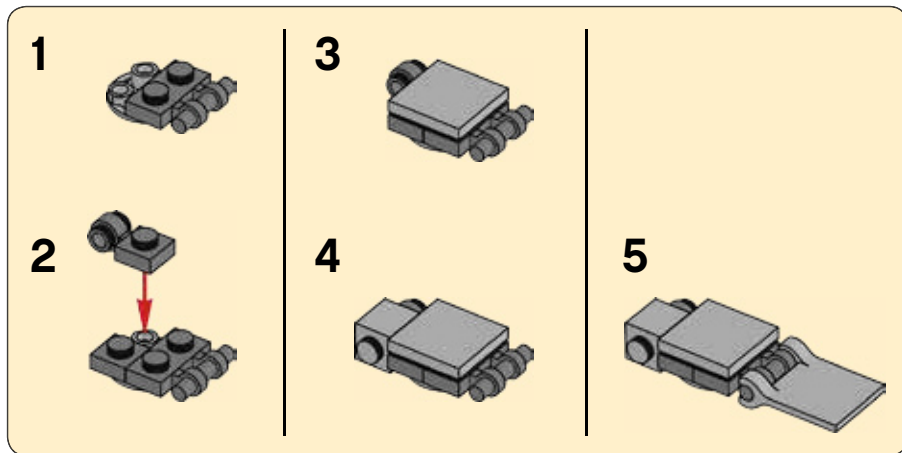

166

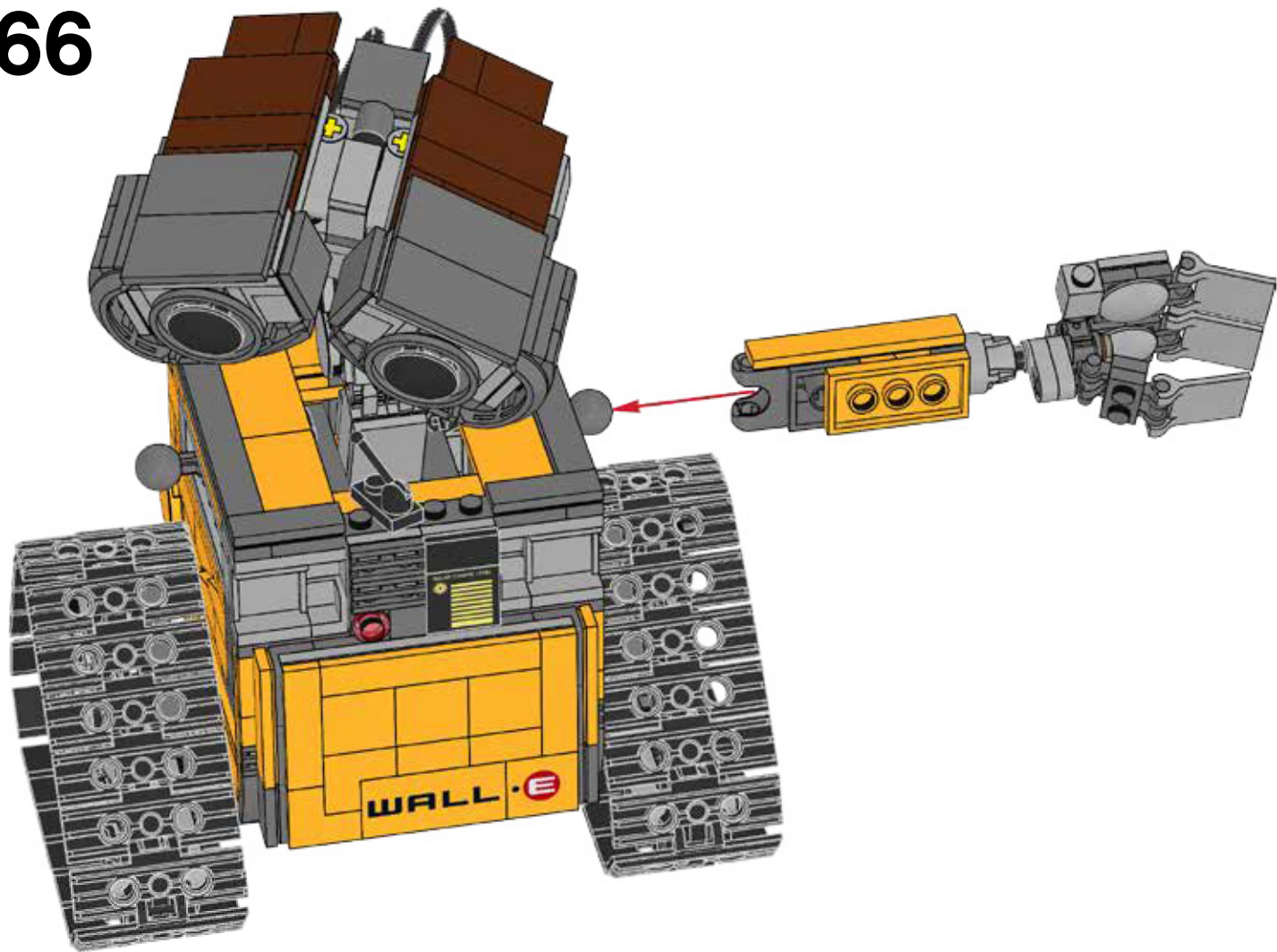

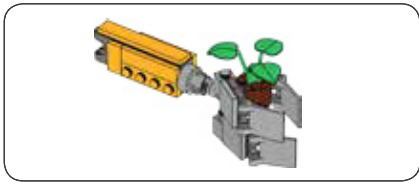

167

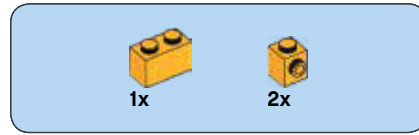

168

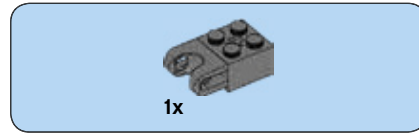
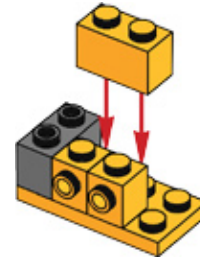

169

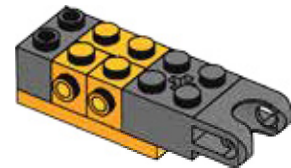



1x



1x

170

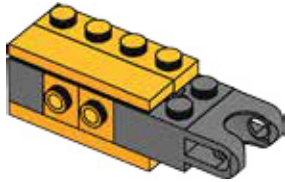

1x



1x

171

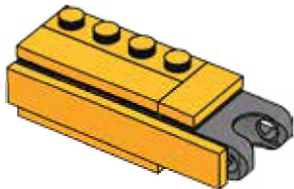

1x



1x

172

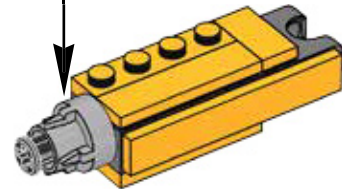
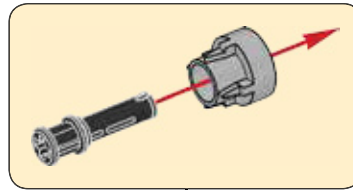



173

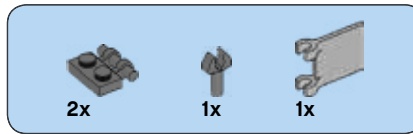
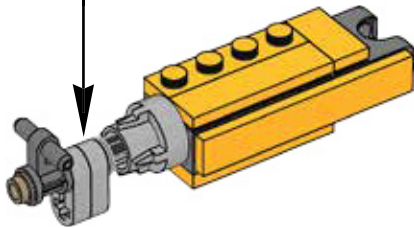
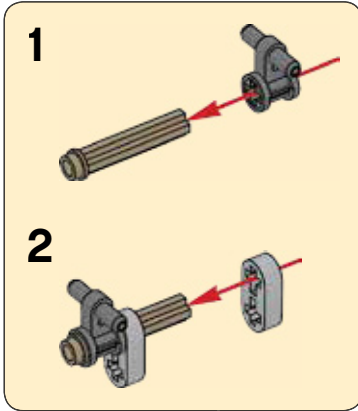

174

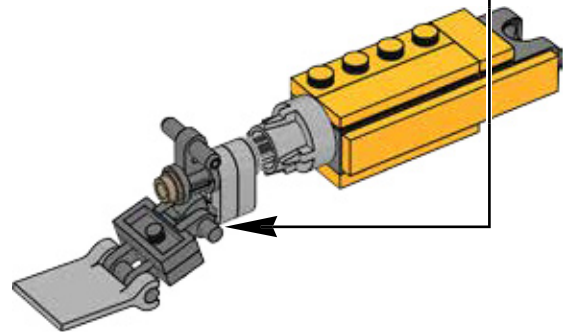
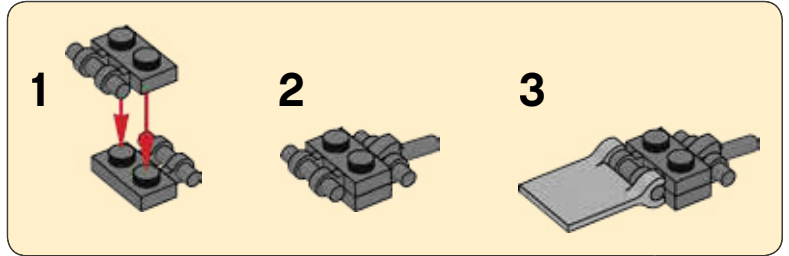

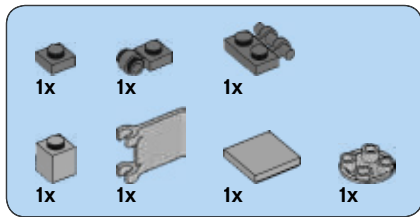

175

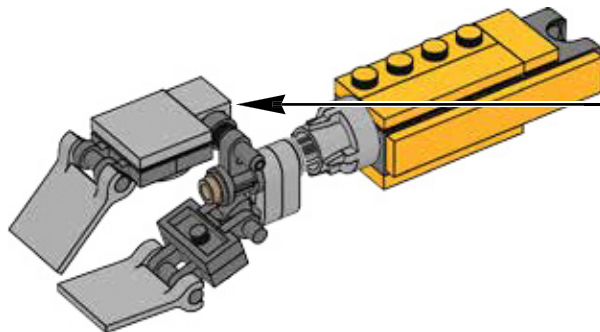
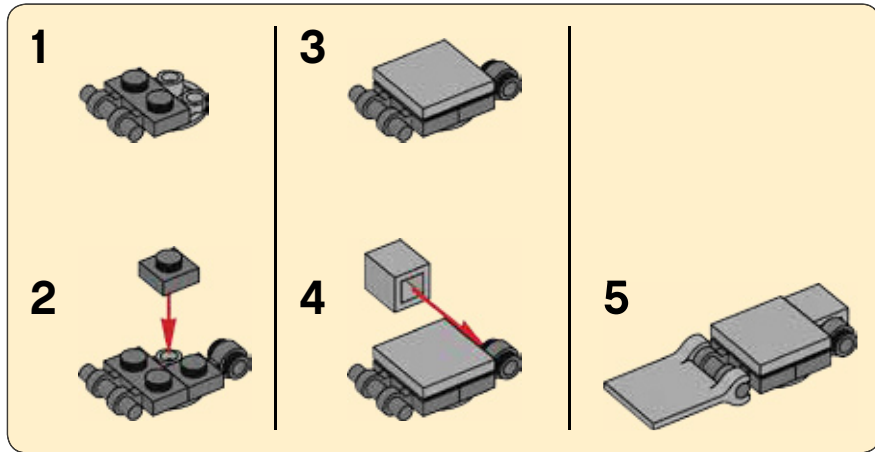

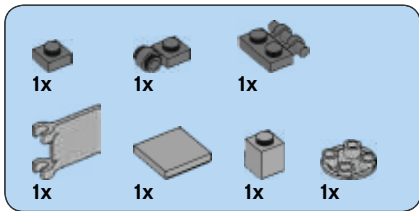

176

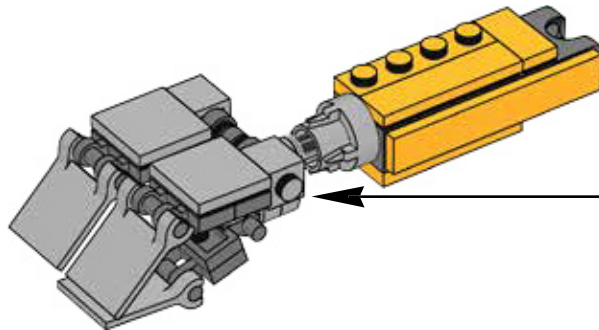
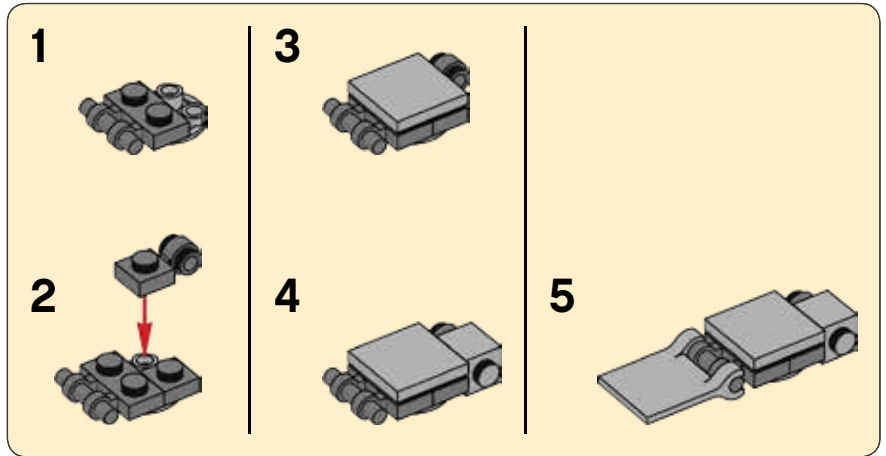



177

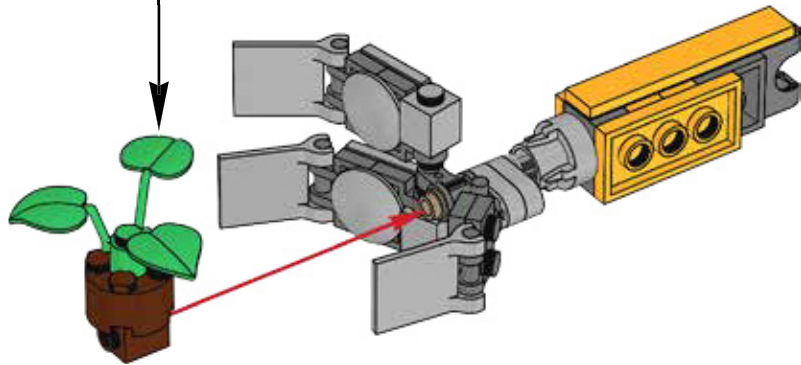
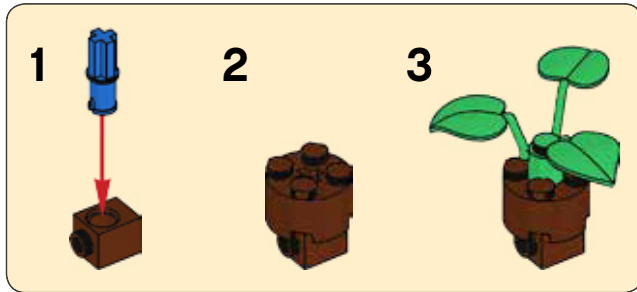

178

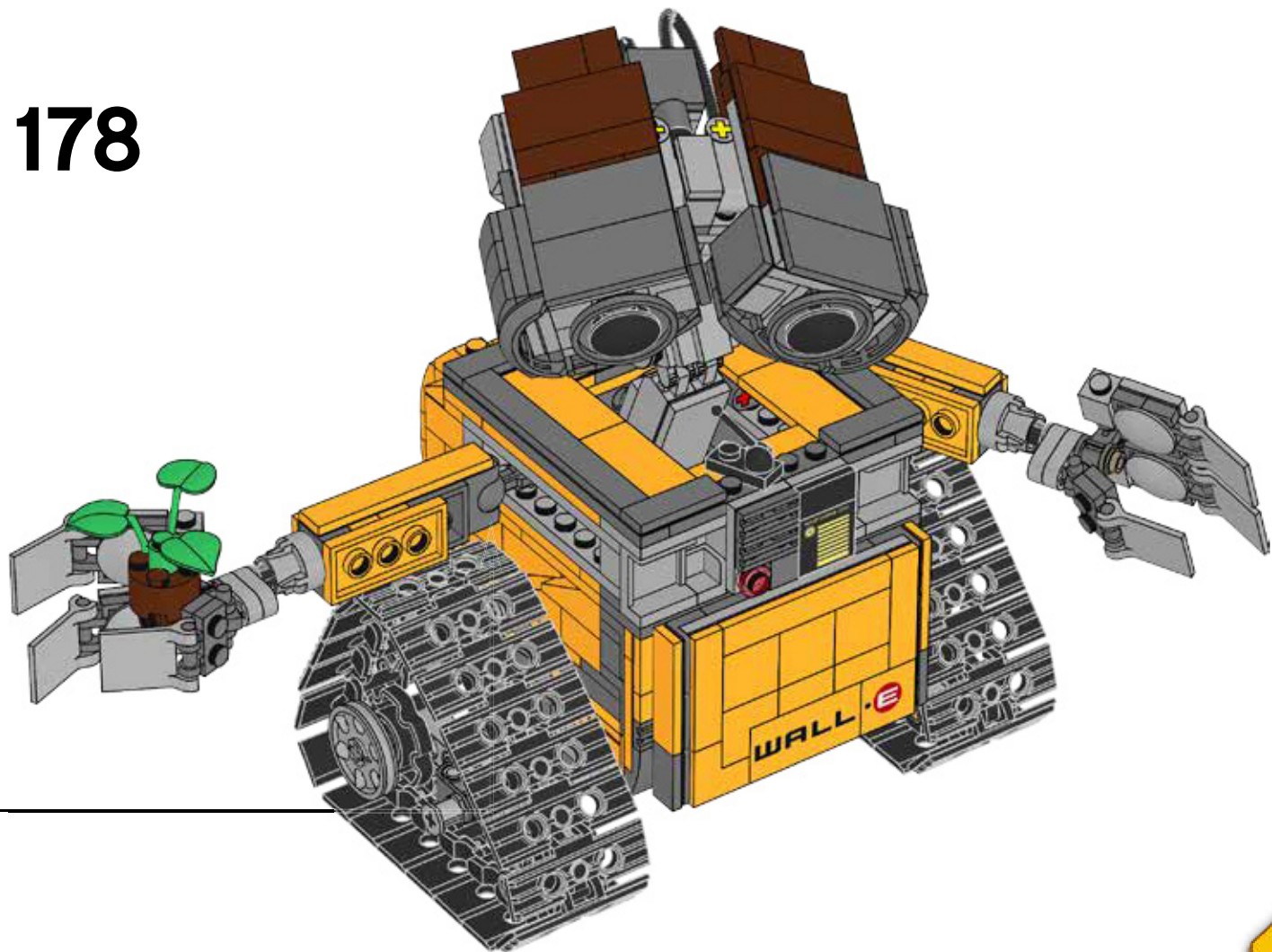

4x
4666579



2x
4142865



2x
4583862



8x
4514553



1x
73587



2x
4550017



2x
4121715



1x
306926



1x
4614788



1x
6132323



8x
4662228



4x
4140801



40x
6014648



2x
346026

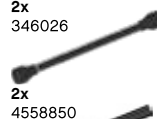

2x
370726



3x
3005741



1x
4654448



6x
6073040



12x
6092035



2x
6131589

6x
6136455



10x
6003003



8x
4622062



6x
6020147



1x
6132324



14x
6034175



4x
6131586

4x
6073042



4x
6131583



7x
6072668



7x
6020073



6x
4621543



7x
4654129



9x
6097509



1x
4211166



4x
4271949



2x
6100769



2x
4211190



2x
4579690



6x
4211573

2x
4211483



8x
4211389



2x
4211415



2x
4278756



4x
4568637



9x
4278273



2x
4211553



4x
4593679



12x
6066097



2x
4211398



3x
4211414



4x
6117967



6x
6011817



1x 6126082
 4x 4211779
 9x 4211397
 4x 4211413
 2x 4211349
 2x 4211694
 2x 6118827
 7x 4211396
 2x 4211386
 1x 4211356
 1x 4560183
 1x 4211444

4x 4646513
 2x 4211695
 2x 6028811
 5x 4211438
 2x 4211404
 6x 4211406
 2x 6102449
 1x 4211462
 2x 4211402
 1x 4211408

3x 4654582
 2x 4211350
 2x 4289542
 4x 4210719
 2x 4504378
 4x 4211044
 1x 4210848
 2x 6020189
 2x 4567887
 4x 4632574
 2x 4210851
 8x 4211063
 1x 6015356

2x 4211088
 13x 4211111
 8x 4210631
 5x 4211052
 4x 6117972
 6x 6000606
 8x 4210660
 2x 4211094
 1x 6013082
 2x 4210635
 2x 6071261
 3x 4211055

2x 4210865
 8x 4211133
 4x 4568734
 2x 4211104
 4x 4246896
 2x 4646522
 3x 6136458
 5x 4210725
 2x 4211001
 6x 4648256
 3x 4619760

4x 4239896
 4x 4560184
 2x 4210686
 2x 4294289
 4x 4211100
 2x 4210651
 4x 4211008

2x 4243831
 5x 4211002
 3x 4257526
 1x 4210678



Customer Service
 Kundenservice
 Service Consommateurs
 Servicio Al Consumidor
 LEGO.com/service or dial

 : 00800 5346 5555
 : 1-800-422-5346



A WHOLE UNIVERSE OF INNOVATIVE LEGO® IDEAS

Do you have an exciting idea for a LEGO® model? Then why not make it into a LEGO Ideas project? You can share your product concept on ideas.LEGO.com and see what other people think about it.

If your project gains 10,000 supporters, it will automatically qualify for the quarterly LEGO Review. This is where we take an in-depth look at the most popular projects and carefully evaluate them to discover the idea with the most

potential. If your project makes it through the review, it will become an official LEGO product.

There are tens of thousands of active members, and thousands of product ideas on LEGO Ideas – several of which have become hit LEGO sets! So take a look, sign up, and support your favorite ideas, or even better: upload your own!

LEGO.COM/IDEAS

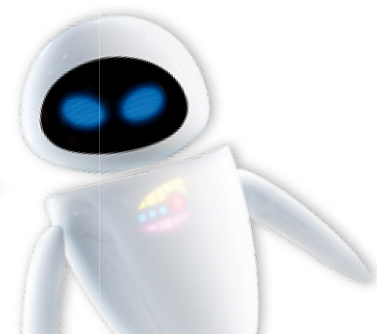

TOUT UN UNIVERS D'IDÉES LEGO® NOVATRICES

As-tu une idée de modèle LEGO® passionnante ? Alors pourquoi ne pas en faire un projet LEGO Ideas ? Tu peux partager ton concept de produit sur ideas.LEGO.com et voir ce que les autres en pensent.

Si ton projet obtient l'appui de 10 000 personnes, il sera automatiquement qualifié pour l'examen LEGO trimestriel. Cet examen nous permet d'étudier en profondeur les projets les plus populaires et de les évaluer attentivement pour découvrir les idées ayant le plus grand potentiel. Si ton projet passe

l'examen, il deviendra alors un produit LEGO officiel.

Il y a des dizaines de milliers de membres actifs et des milliers d'idées de produits sur LEGO Ideas, et plusieurs d'entre elles sont devenues des ensembles LEGO très populaires ! Alors va regarder, inscris-toi et soutiens tes idées préférées. Ou mieux encore : télécharge ton propre projet !

LEGO.COM/IDEAS

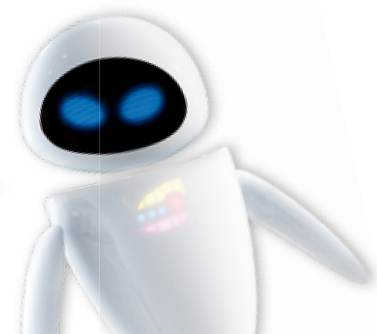

TODO UN UNIVERSO DE INNOVADORAS IDEAS LEGO®

¿Tienes una buena idea para un modelo LEGO®? ¿Por qué no convertirla en un proyecto LEGO Ideas? Puedes compartir tu idea en ideas.LEGO.com y ver lo que los demás piensan de ella.

Si tu proyecto consigue 10.000 votos, se clasificará automáticamente para la revisión trimestral de LEGO. Es entonces cuando daremos un vistazo a los proyectos más populares y los evaluaremos detenidamente para determinar qué idea tiene más potencial.

Si tu proyecto supera la revisión, se convertirá en un producto LEGO oficial.

Hay decenas de miles de miembros activos y miles de ideas en LEGO Ideas (varias de las cuales ya se han convertido en sets LEGO de gran éxito). Ven a dar un vistazo, regístrate y apoya tus ideas favoritas. O aún mejor: ¡envía la tuya!

LEGO.COM/IDEAS

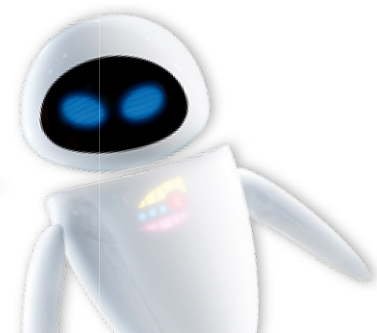
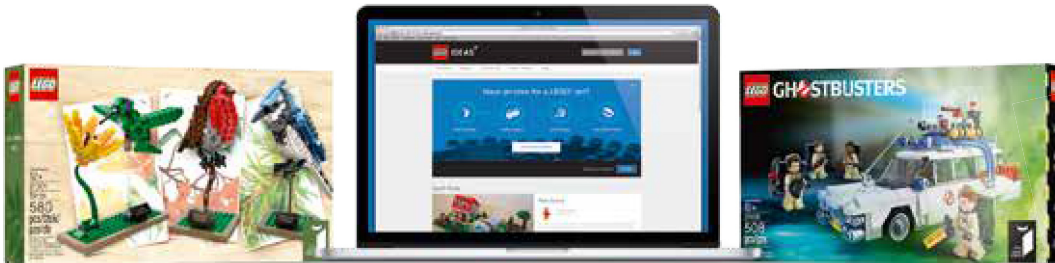



WIN

GO TO WWW.LEGO.COM/PRODUCTFEEDBACK AND
GIVE US YOUR SHORT **FEEDBACK** ABOUT THIS
LEGO® SET FOR A CHANCE TO WIN
A COOL LEGO PRIZE.



LEGO.com/productfeedback

GEWINNE



Erzähle uns auf
www.LEGO.com/productfeedback

etwas über die Erfahrungen, die du mit
diesem LEGO® Set gemacht hast, und
sichere dir die Chance auf einen coolen
LEGO Preis!

GAGNE



Rends-toi sur
www.LEGO.com/productfeedback

et donne-nous quelques commentaires
sur ce produit LEGO® pour avoir une
chance de gagner un prix LEGO !

GANAN



Visita
www.LEGO.com/productfeedback

y envíanos tu opinión acerca de este set
LEGO®. ¡Participarás en el sorteo de un
premio LEGO!

获取奖品



登录
www.LEGO.com/productfeedback

给出关于此乐高®套装的简短反馈，
就有机会获得炫酷乐高奖品

LEGO and the LEGO logo are trademarks of the/son des marques de commerce du/son marcas registradas de LEGO Group. ©2015 The LEGO Group.

© Disney/Pixar

6162871