



MINDSTORMS™

START HERE

ROBOTICS DISCOVERY SET™



1

The Bug Book

9735

CONSTRUCTION

Welcome!

The LEGO Mindstorms Robotics Discovery Set lets you build robots that do what you want them to do. You can build things like...

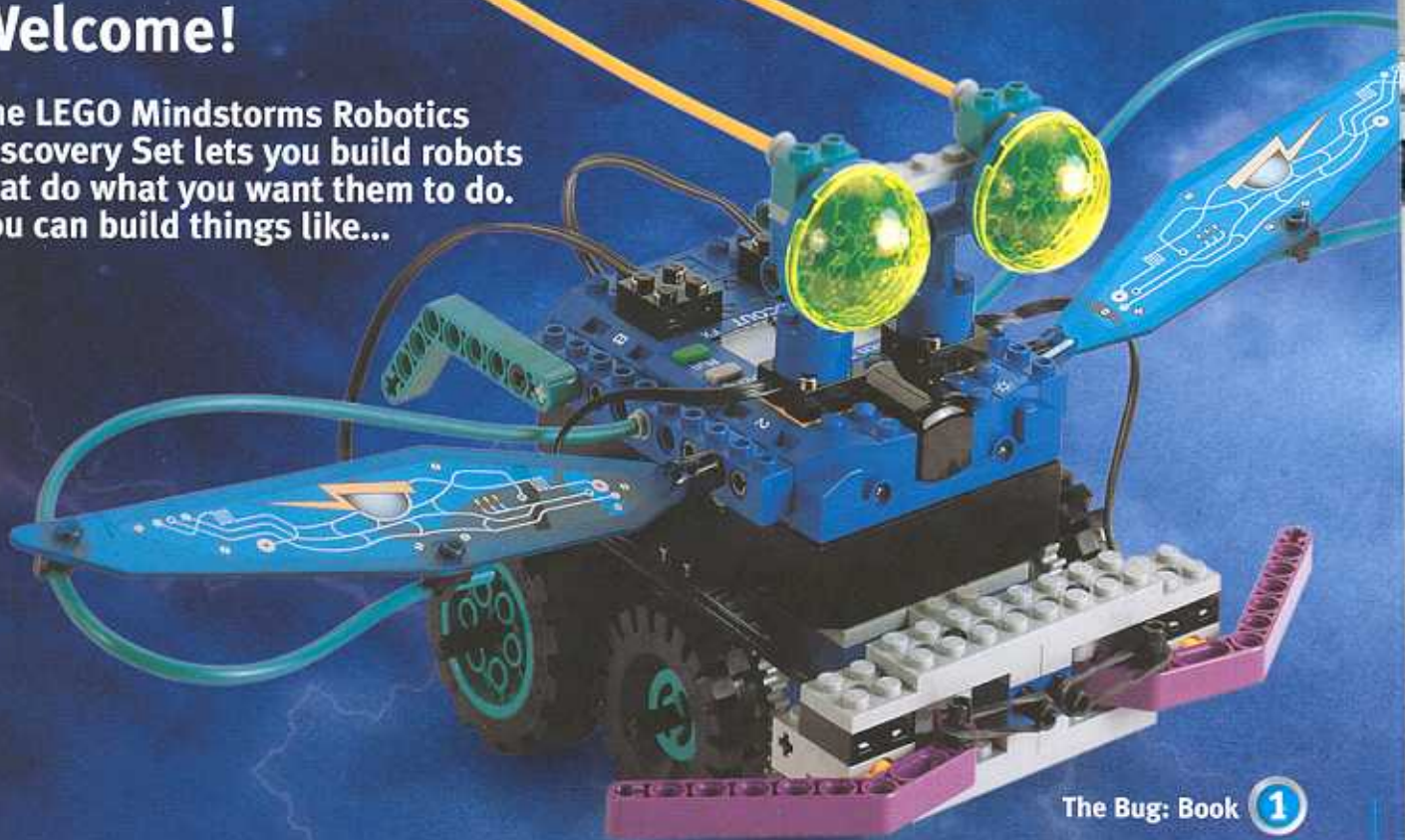

The Bug: Book 1

A robotic insect that can explore your house.

The Intruder Alarm: Book 2

A light-triggered alarm to keep people out of your room.

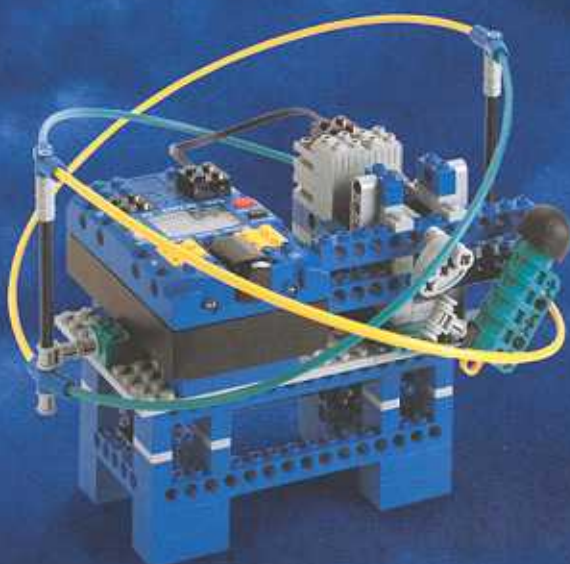

The Hoop-o-bot: Book 3

A robotic basketball hoop that can challenge you to a game.



...and other things found only in the depths of your imagination.

CONTENTS

Introduction	<i>page 2</i>
Getting Started Installing Batteries, Connecting Motors, Connecting Touch Sensors, Using the Light Sensor, Using the Buttons and the Display	<i>page 4</i>
Building Instructions	<i>page 11</i>
Explorations	<i>page 33</i>
<i>Part 1 – Making your Bug Move</i>	<i>page 36</i>
<i>Part 2 – Making your Bug Feel</i>	<i>page 37</i>
<i>Part 3 – Making your Bug See</i>	<i>page 41</i>
<i>Part 4 – Speeding up your Bug</i>	<i>page 42</i>
<i>Part 5 – Adding Special Effects</i>	<i>page 43</i>
Challenges	<i>page 45</i>
<i>Special Features</i>	<i>page 50</i>
<i>Tips & Tricks</i>	<i>page 52</i>
Extras	
<i>Frequently Asked Questions</i>	<i>page 54</i>
<i>Technical Stuff</i>	<i>page 56</i>

Meet the Scout

The Scout will make all of your inventions come alive (you can even hear its heart beat).

The Scout looks like a LEGO brick, but it is also a powerful microcomputer.

- The Scout can control two LEGO Motors to make things move.
- It can feel objects using two LEGO Touch Sensors.
- It can see changes in light.
- Plus, it can do some other cool tricks...



*You tell the Scout what to do
by using the buttons and the display
screen on the top.*

How it Works

Scout inventions work a lot like real living creatures, only they are electronic.

1. The Scout uses its sensors to watch for changes in the world around it.
2. The sensors detect when something happens, such as when your robot runs into a wall.
3. A signal is sent from the sensor to the Scout's brain (a computer chip).
4. The brain decides what to do, such as turn on motors, lights, and sounds.

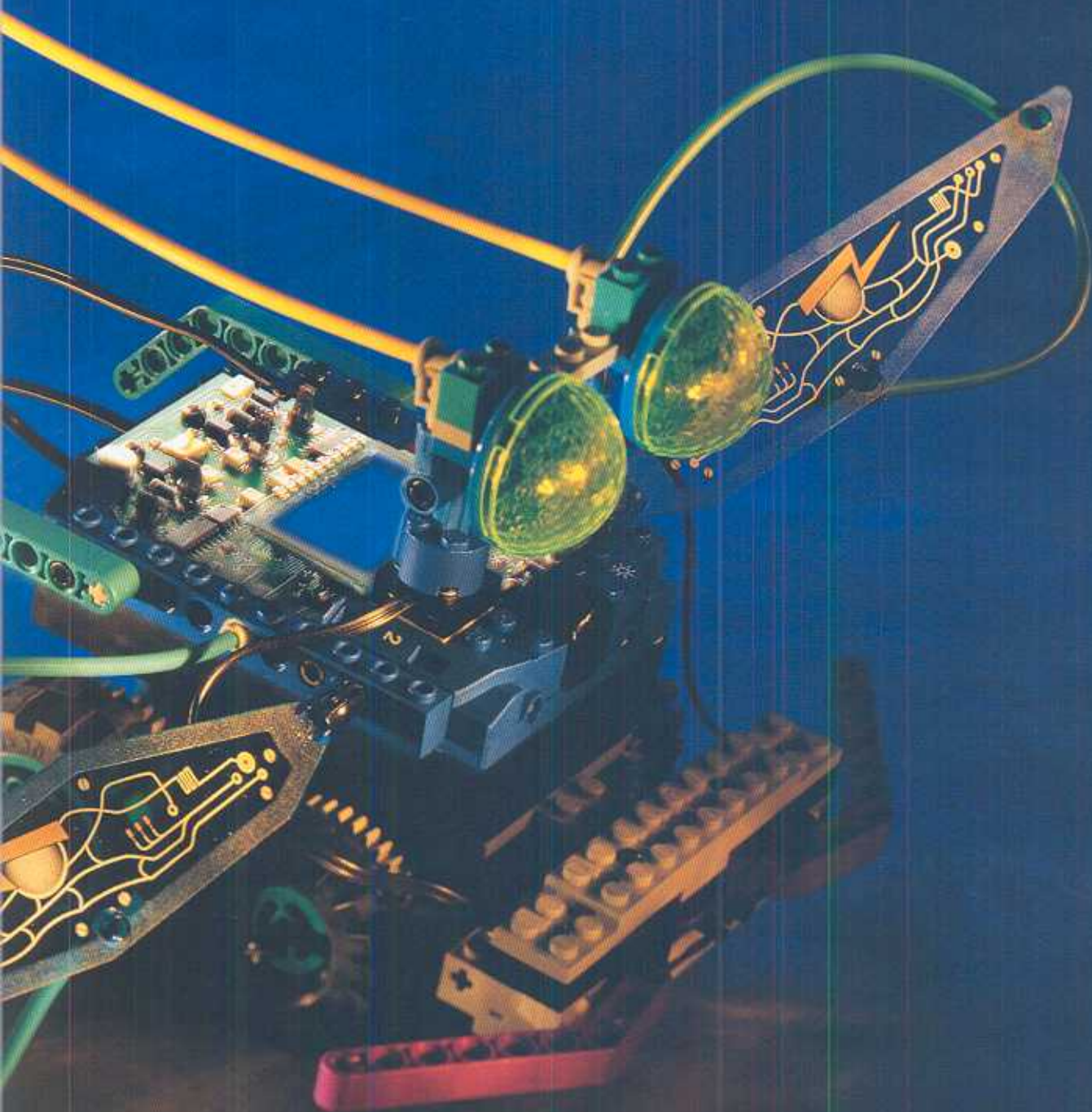



INSTALLING BATTERIES

The Scout requires 6 AA (LR6) batteries, which are not included. Alkaline batteries are recommended.

1. Lift the top off the Scout brick.
2. Install the batteries.



3. Put the Scout back together.



Important:

When the Scout's batteries are low, a battery icon  appears on the display.

Instructions for use of battery box

Never mix different types of batteries, or old and new batteries in one battery box.

Always remove the batteries from the battery box for long-term storage, or if they have reached the end of their life. Liquid leaking from dead batteries will damage the battery box. Rechargeable batteries should be recharged under adult supervision. Tested to comply with FCC Standards - FOR HOME OR OFFICE USE.

FCC Statement:

This device complies with Part 15 of the FCC Rules. Operation is subject to the following 2 conditions:

1. This device may not cause harmful interference.
2. This device must accept any interference received including interference that may cause undesired operation.

Warning:

Changes or modifications to the Scout not expressly approved by the party responsible for the compliance could void the user's right to operate the equipment.

Checkpoint 1: Battery Check

1. Press the On-Off button.

The Scout will beep and flash the word "Forward" on its display. You should also hear a faint heart beat.



CONNECTING MOTORS

The motors control the different movements of your invention. Motors can turn wheels, move arms, fire launchers, and throw balls.

1. Attach one end of a long black wire to a motor.
2. Attach the other end of the wire to the black square labeled A on the Scout.

The black squares are called motor ports.

3. Attach another motor to port B using the other long wire.

For the Bug model, make sure you connect the motors like this:



Checkpoint 2: Motor Check

1. Make sure the Scout is turned on.
2. Press the green Run button.

Both motors should spin.

The green triangles next to the motor ports will light up.

3. Press the Run button again.

The motors should stop.

The Run button both starts and stops programs.



CONNECTING TOUCH SENSORS

Touch sensors are like the tips of your fingers. They let the Scout touch and feel things in the world around it.

1. Attach one end of a short black wire to a touch sensor brick.
2. Attach the other end of the wire to a yellow square on the Scout.

The yellow squares are called touch sensor ports.

3. Attach another touch sensor in the same way using another short wire.

To make the touch sensor work correctly, attach the wire like this:

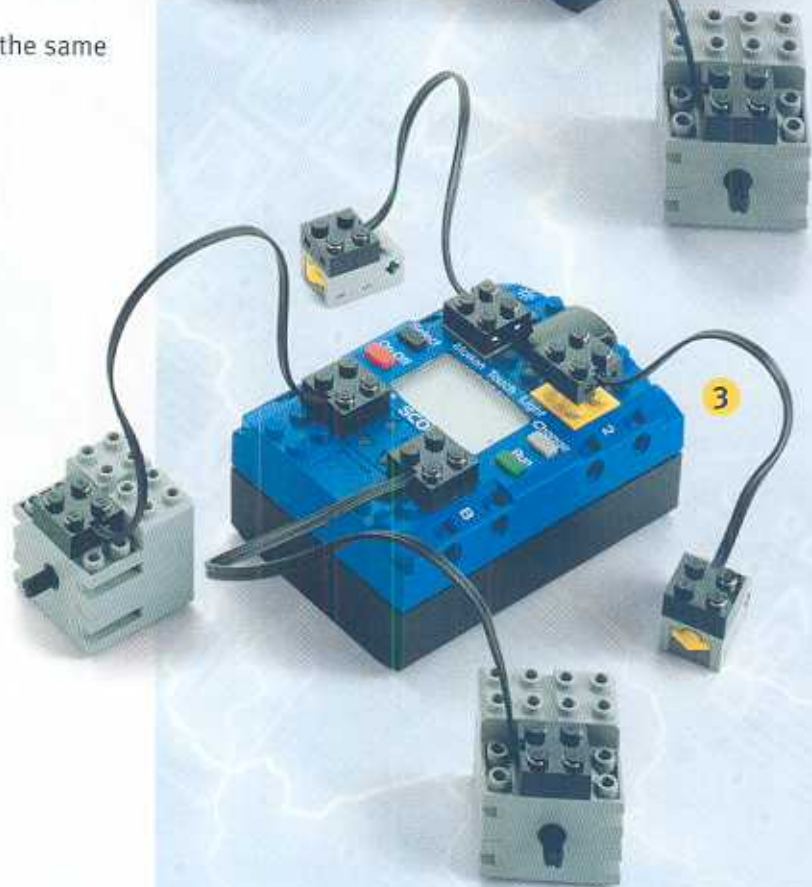
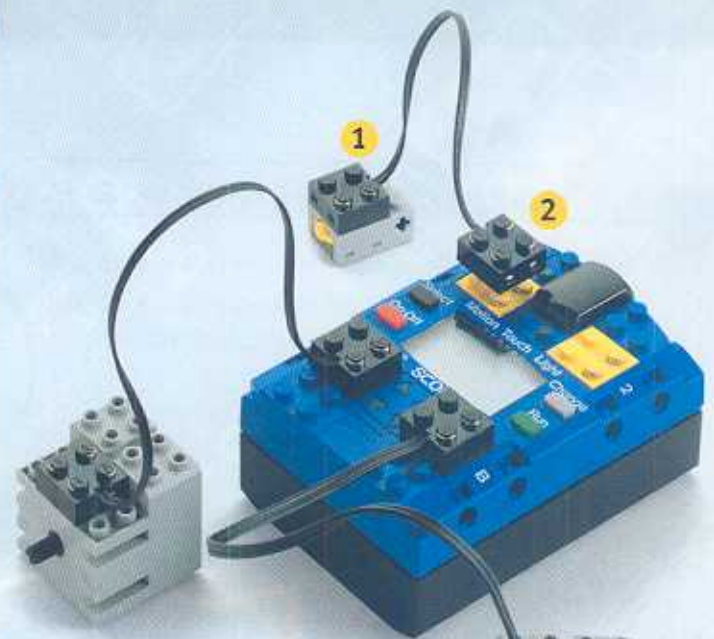

Checkpoint 3: Touch Sensor Check

1. Make sure the Scout is turned on.
2. Press the yellow button at the tip of one of the touch sensor bricks.

The Scout will make a sound. A light on the Scout will show you which touch sensor is being pressed.



USING THE LIGHT SENSOR

A light sensor is built into the front of the Scout. It lets the Scout detect changes in light.

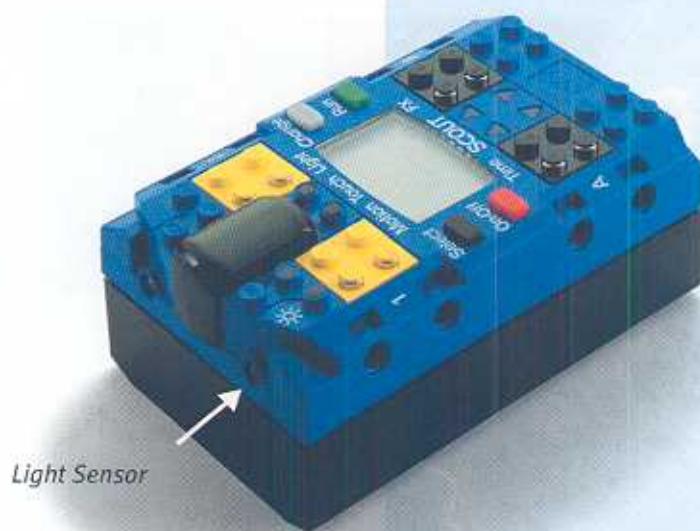

Light Sensor

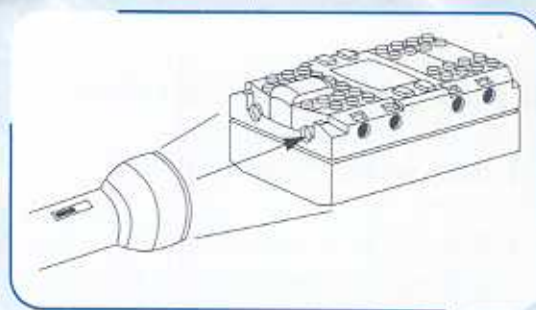

Checkpoint 4: Light Sensor Check

1. Make sure the Scout is turned on.
2. Aim the Scout at a bright light, like a lamp or a sunny window.
3. Press Run.
4. Put your hand over the light sensor.

The Scout will make a sound when it sees the shadow of your hand.

The yellow light next to the symbol will also light up.



USING THE BUTTONS

The buttons and commands on the display let you tell the Scout what to do.

Select The Select button lets you switch from one group of commands to another.

Press Select to move to another group.



On-Off The On-Off button turns the Scout on and off.

To reset the Scout, hold the On-Off button down for 2 seconds while the Scout is on.

Change The Change button lets you choose a command within a group.

To clear the commands within a group, press Change until all of the commands are flashing.

Run The Run button starts and stops the Scout.

When the program is running, you will see arrows flashing across the display.

Checkpoint 5: Command Check

1. Make sure the Scout is turned on.
2. Press the black Select button until the commands under Motion are flashing.
3. Press the gray Change button until the Forward command is flashing.
4. Press the black Select button until the commands under Touch are flashing.
5. Press the gray Change button until the Reverse command is flashing.
6. Press Run.
The motors should start spinning.
7. Press the yellow part of a touch sensor brick.
The motors should change direction.
8. Press Run to stop.

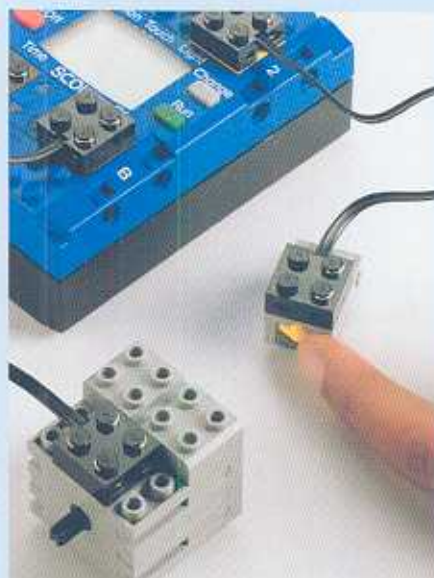

THE DISPLAY

The Scout's display has five groups of commands. You will explore these commands later in this book.

Motion

Motion: Sets the Scout's basic movements.

For more information look at page 36.

Touch

Touch: Tells the Scout how to react to touch.

For more information look at page 37-40.

Light

Light: Tells the Scout how to react to light.

For more information look at page 41.



Time: Tells the Scout how fast to run the commands.

For more information look at page 42.

Time

FX commands add special sounds and movements to your programs.

**FX* stands for "Special Effects."*

For more information look at page 43.

FX

The  symbol shows the Scout is on.

You can use the Change button to put the Scout into Power Mode .

*To use Power Mode, you will need to have a Scout Booster Set.**

SCOUT

**Sold separately. Available late 2000. Check out www.legomindstorms.com for more information.*

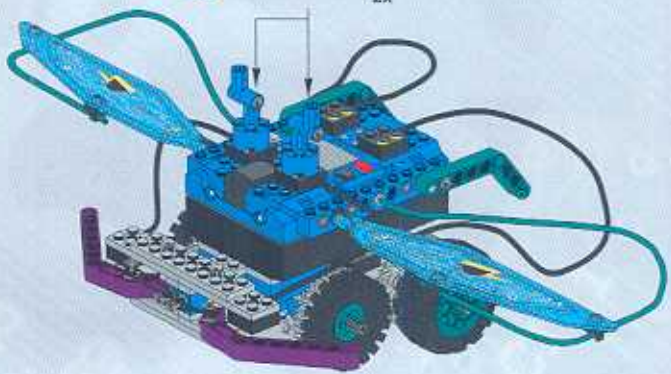
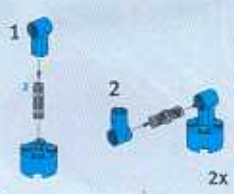
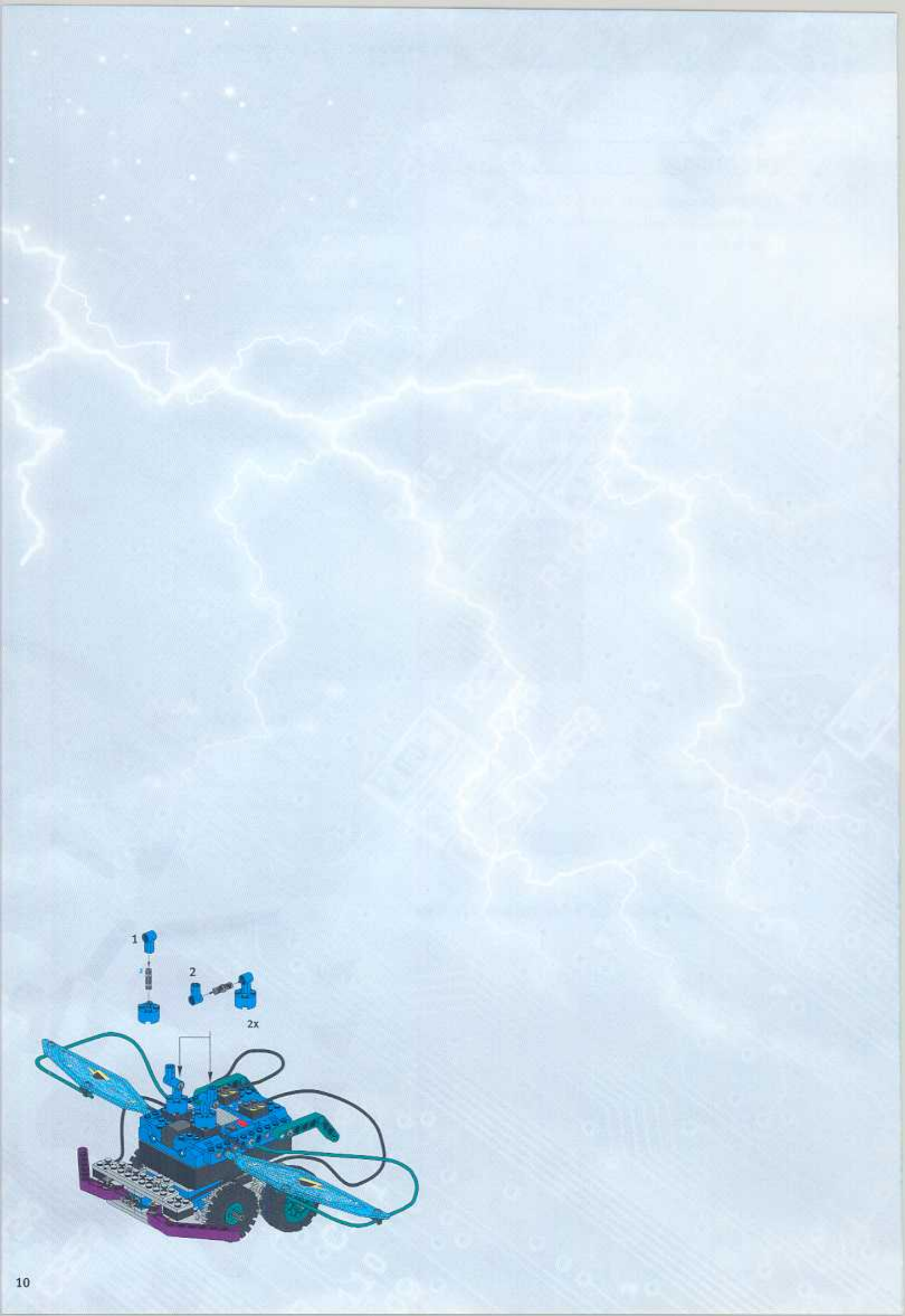

BUILDING INSTRUCTIONS



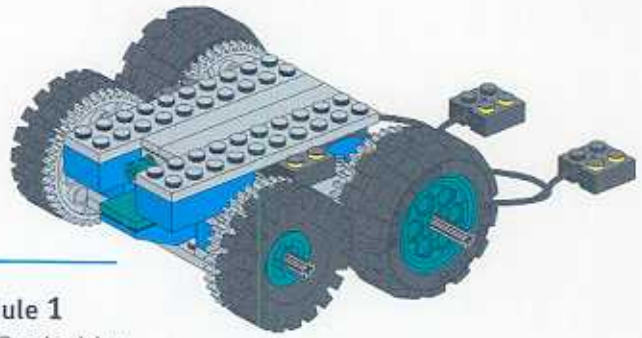

Module 1
The Bug's drive.

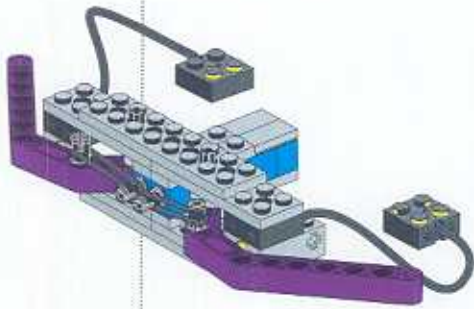

Module 2
The Bug's feelers.

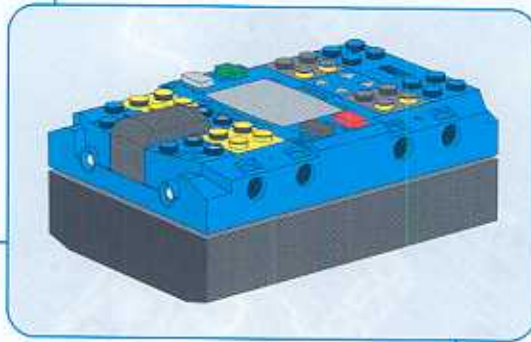

Module 3
The Bug's eyes and wings
(for decoration).

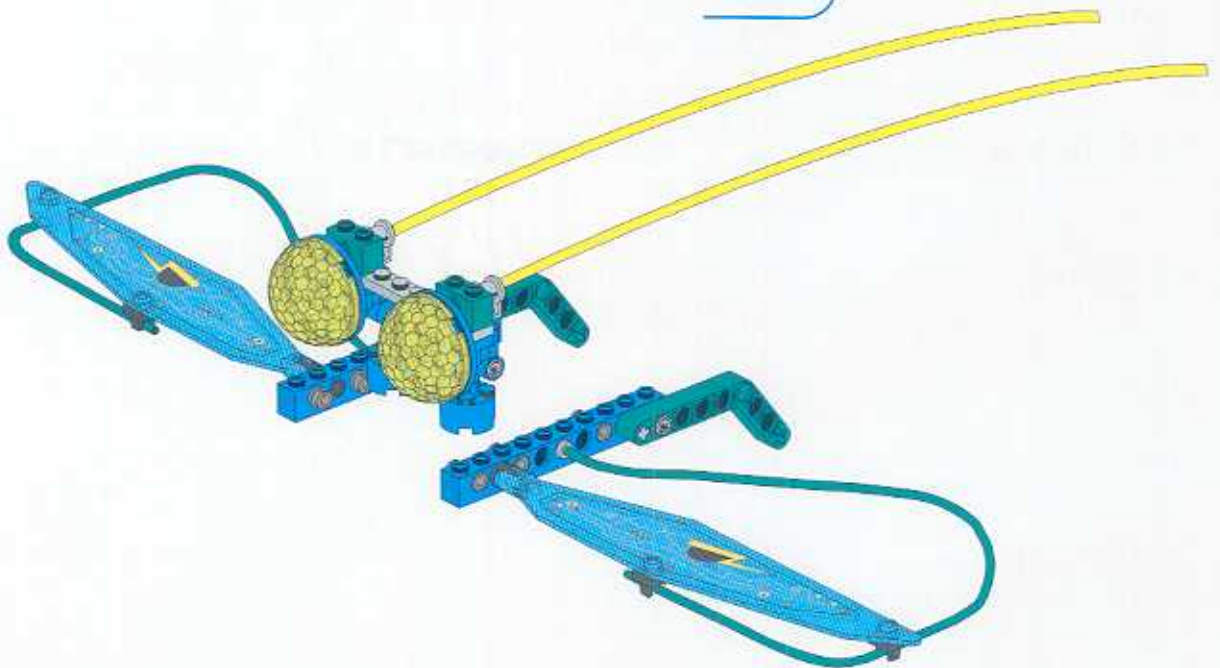

1

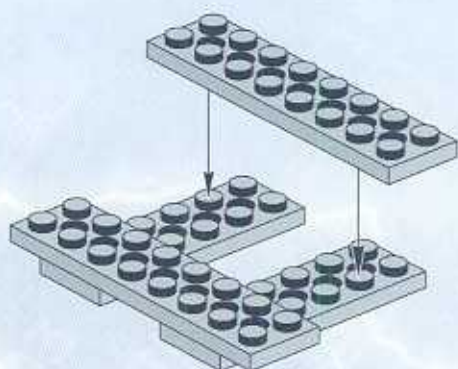
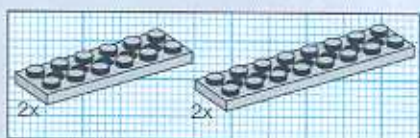

2

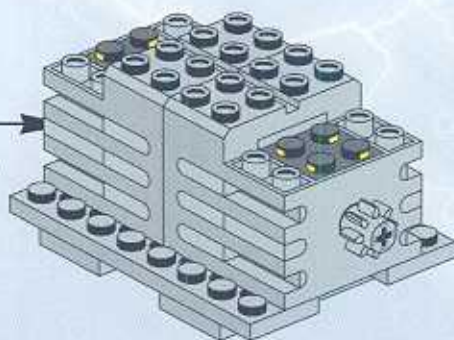
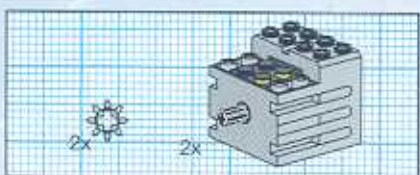



Check out the back page for how to measure axles and beams.

3

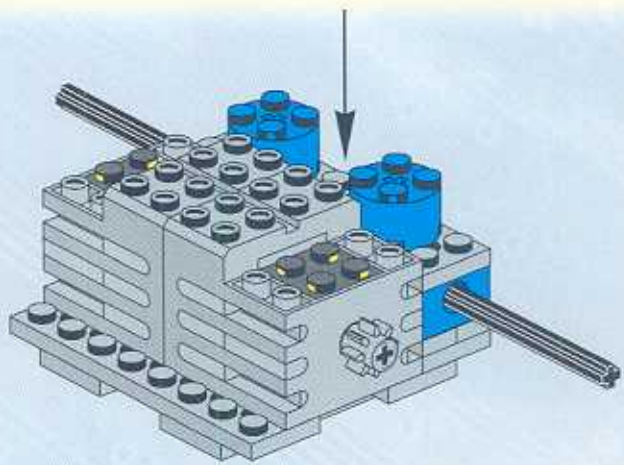
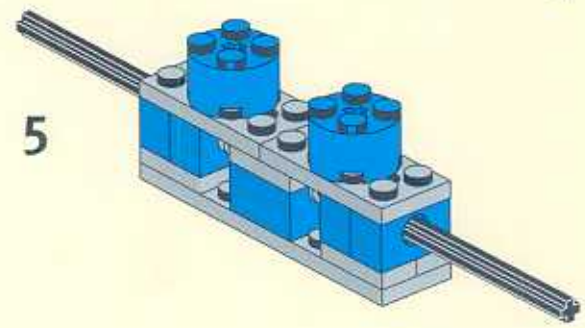
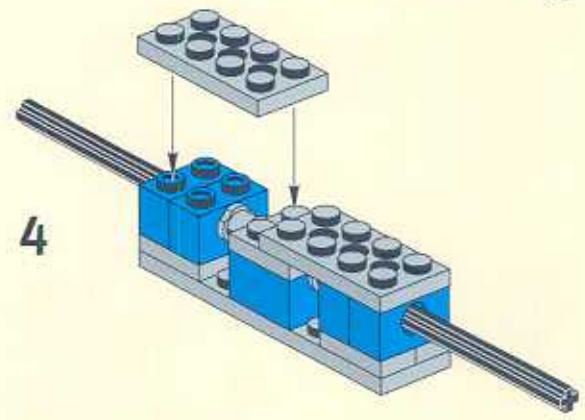
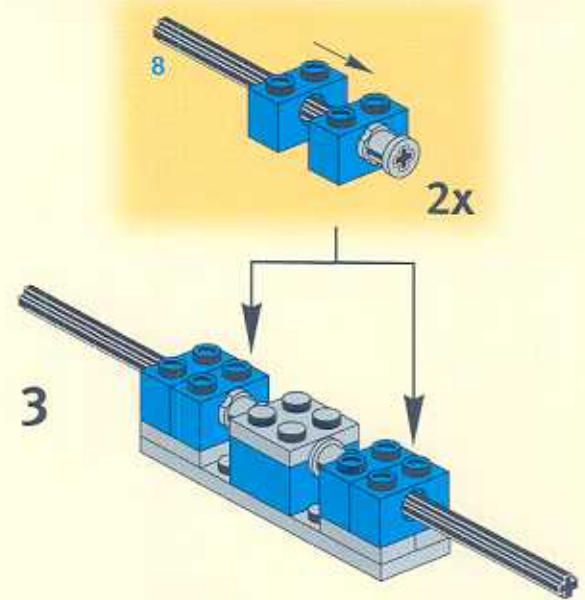
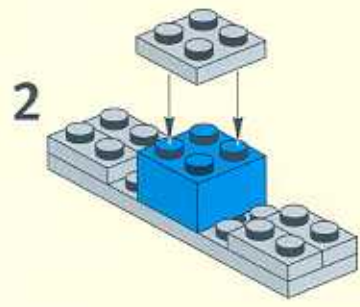
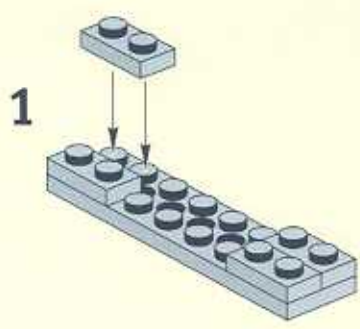
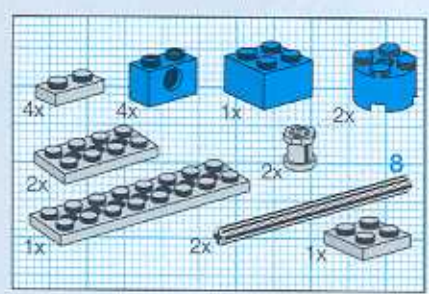



4

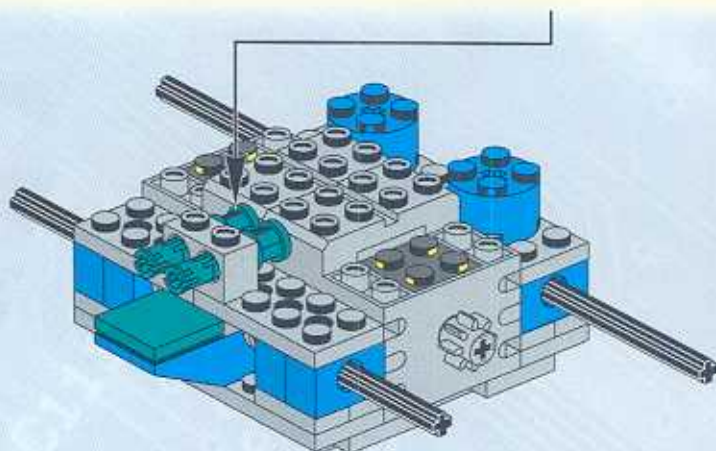
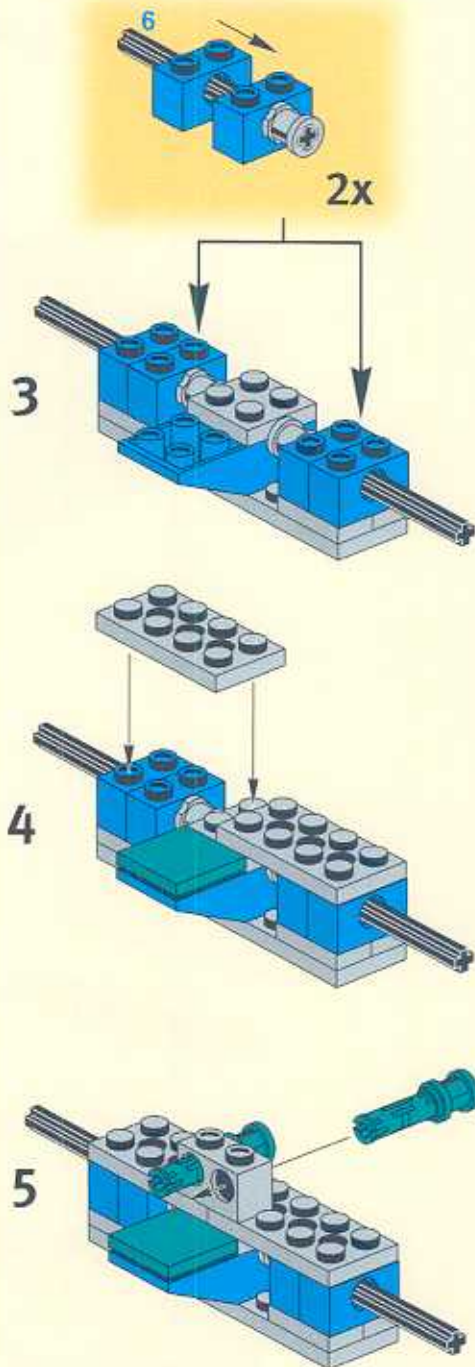
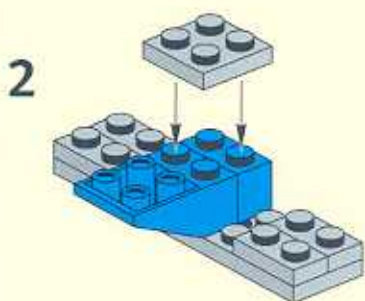
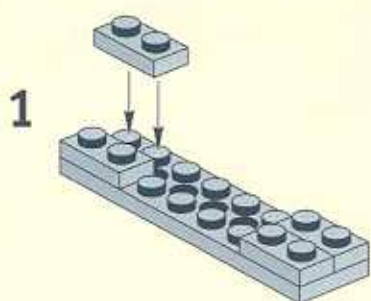
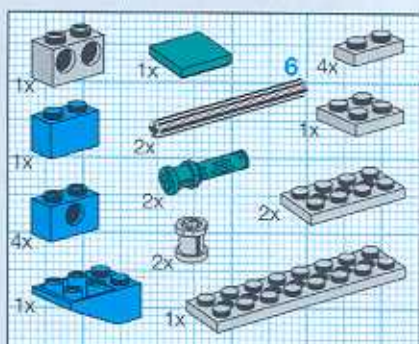



5

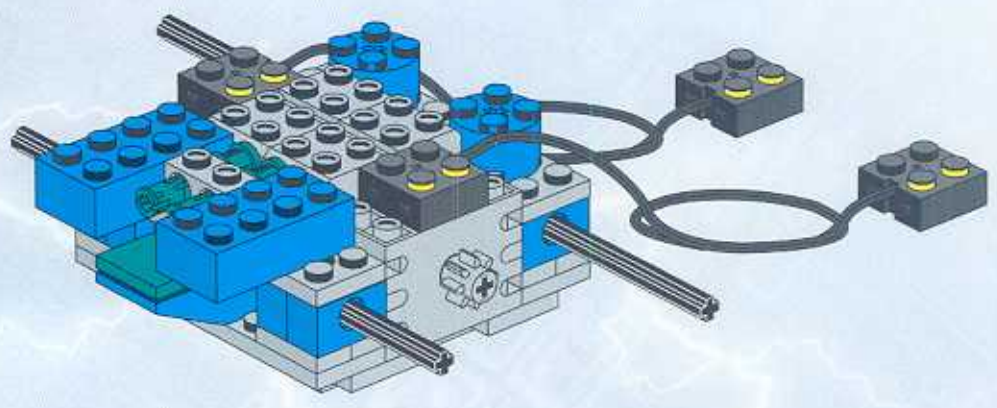
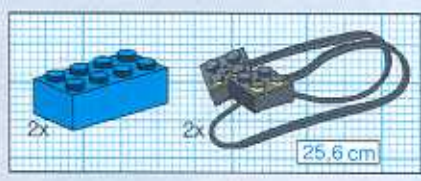

6

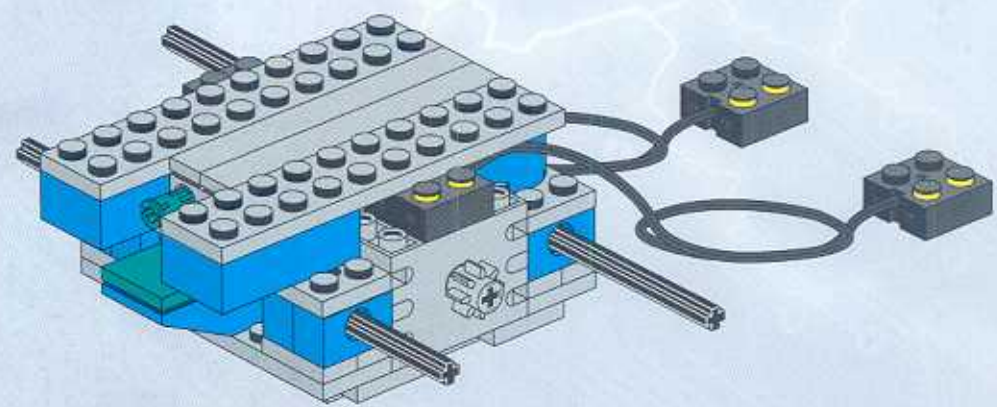
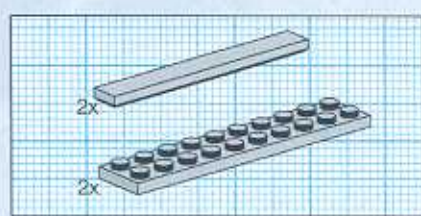



7

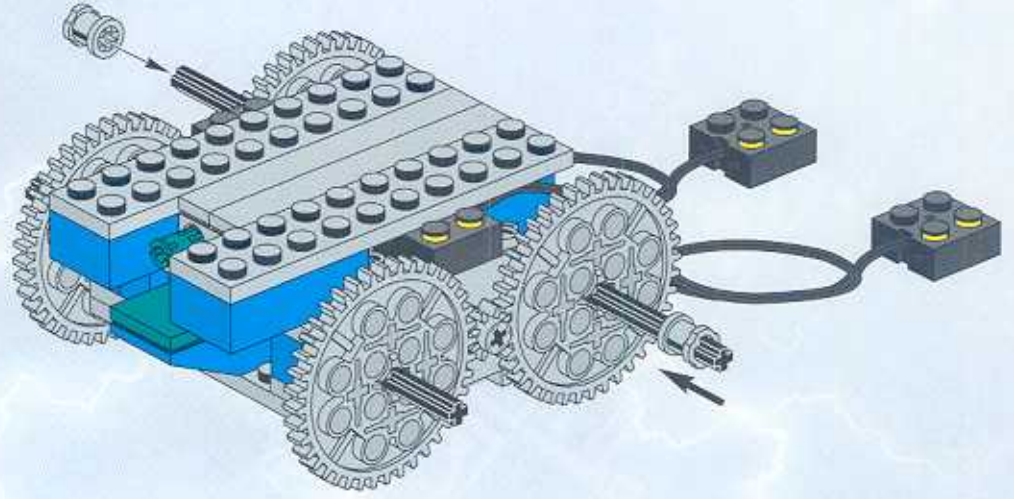

8

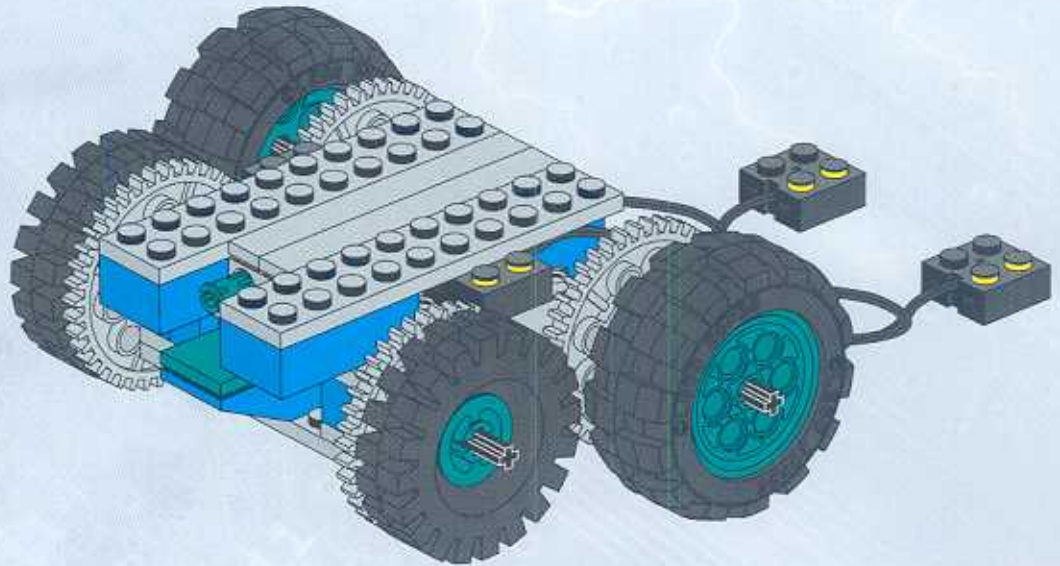
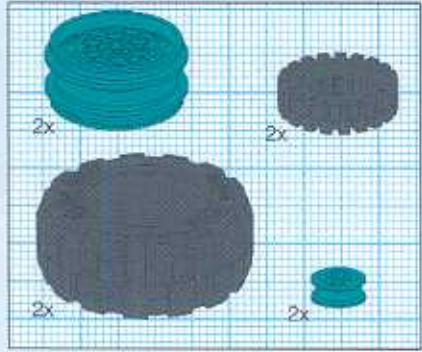



Module 2

9

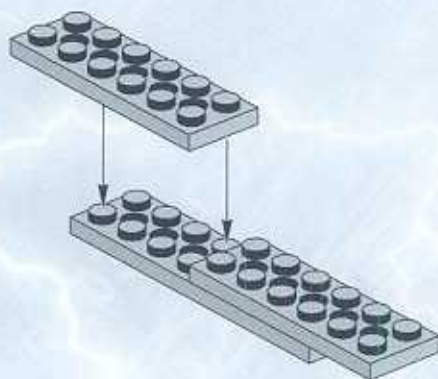
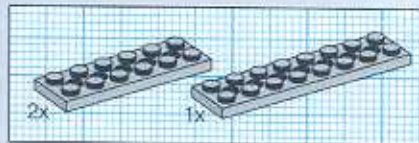

10

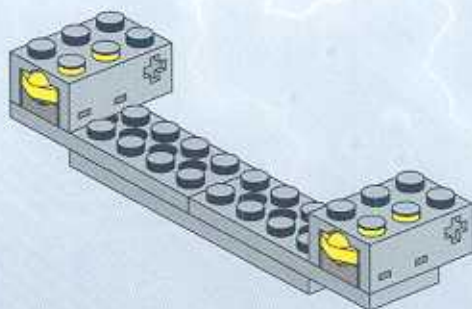

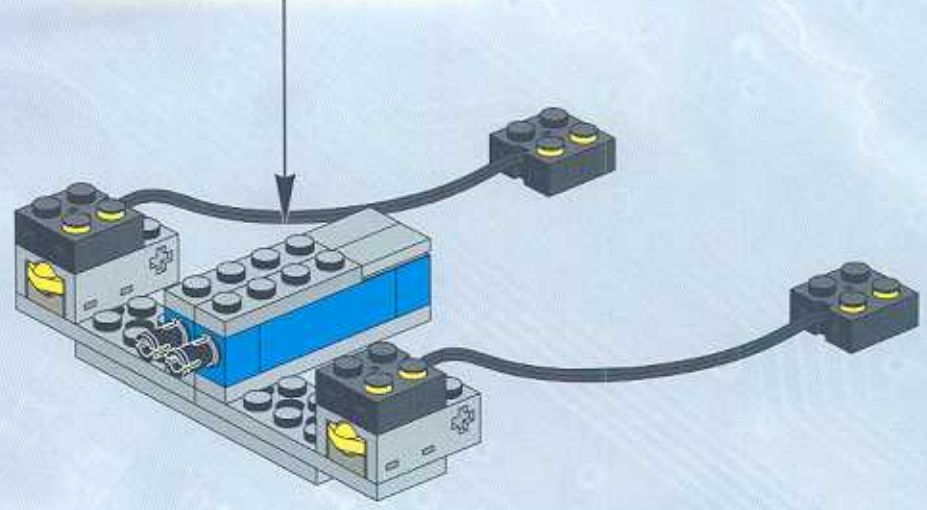
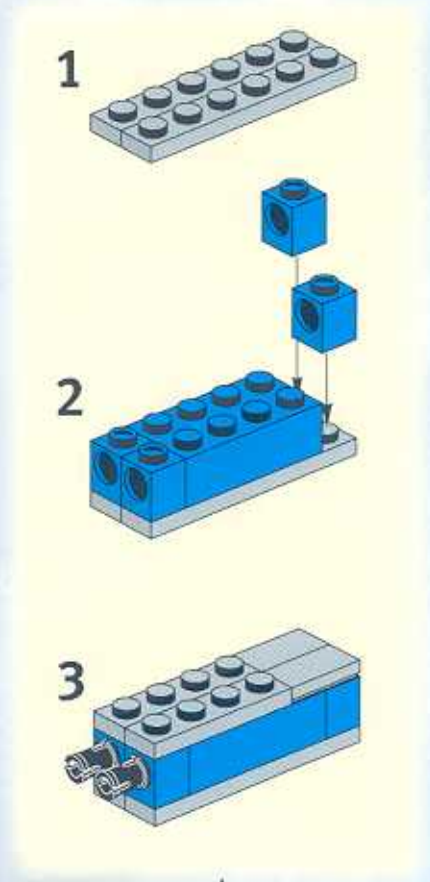
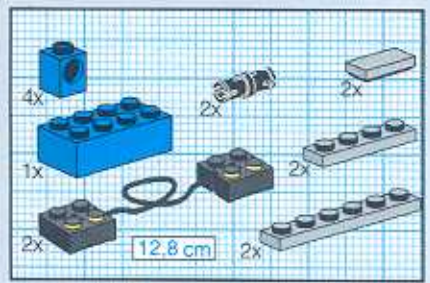



12

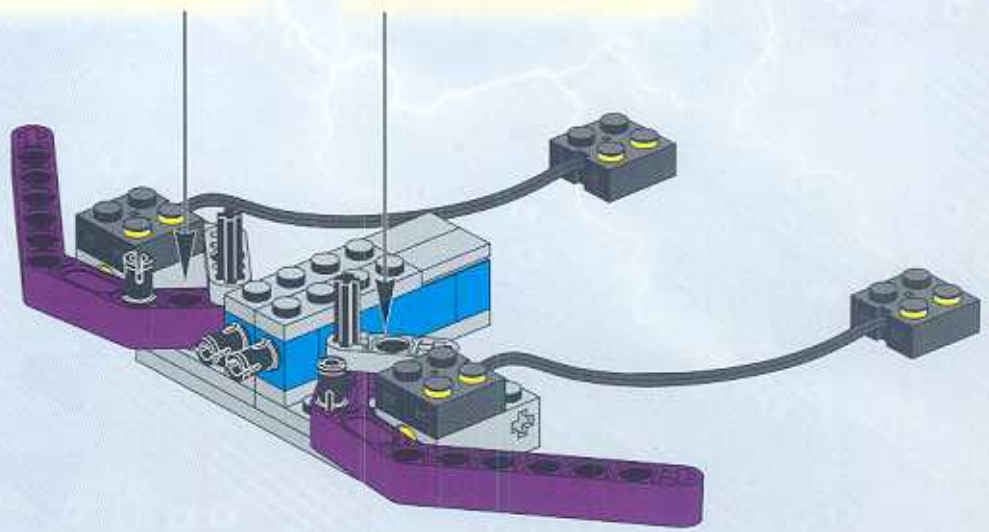
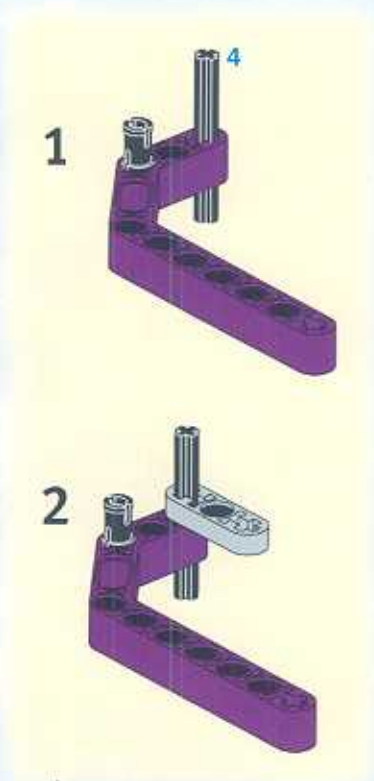
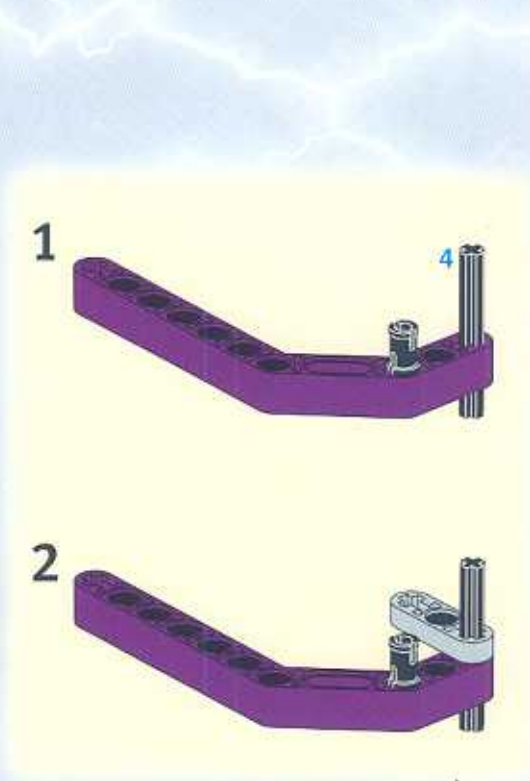
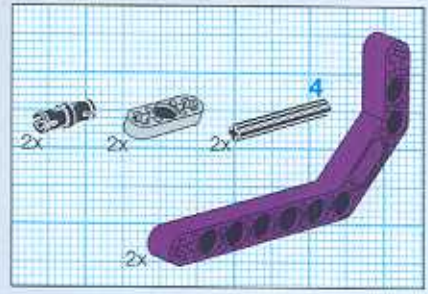

13

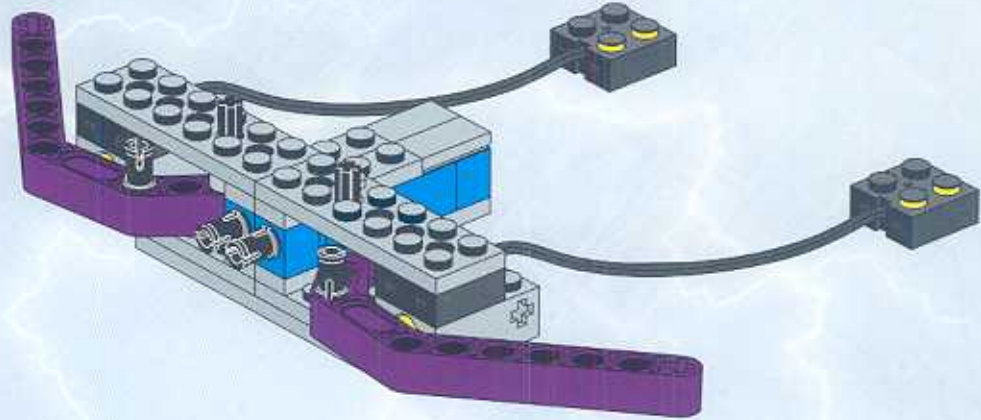
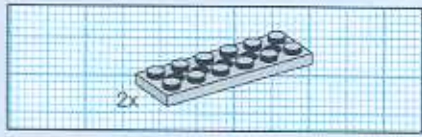

14

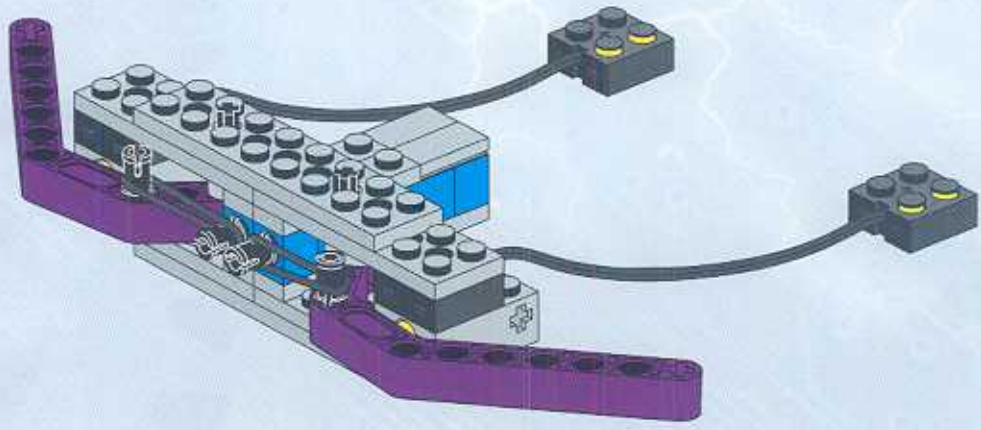

15

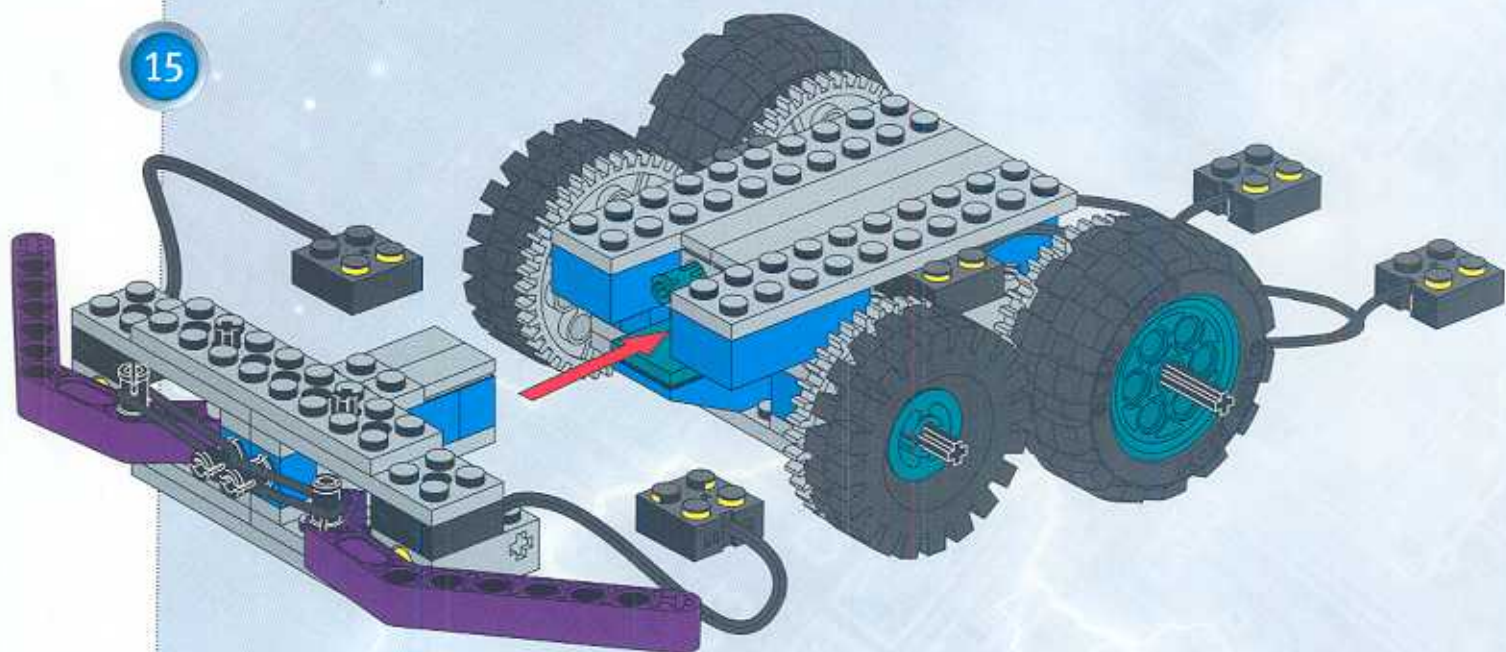

16

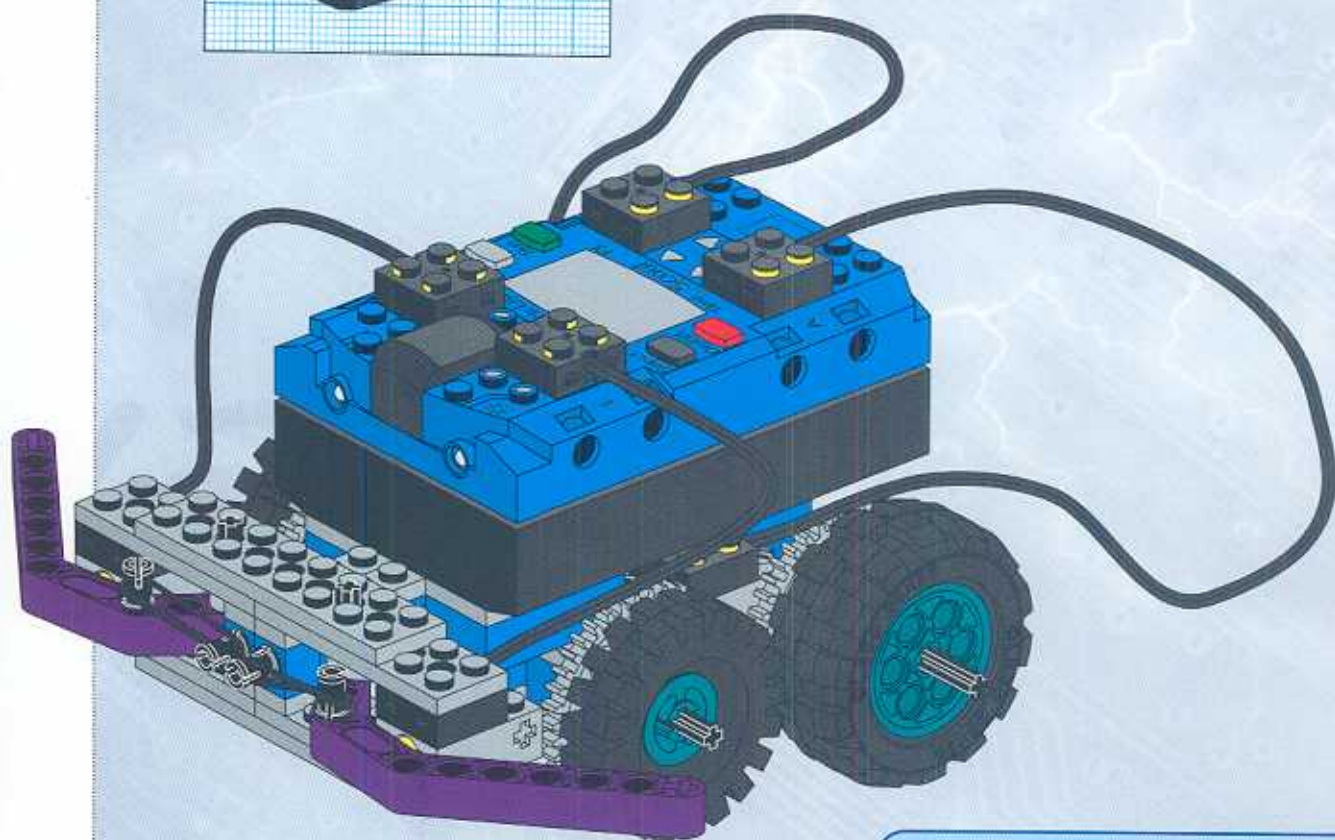
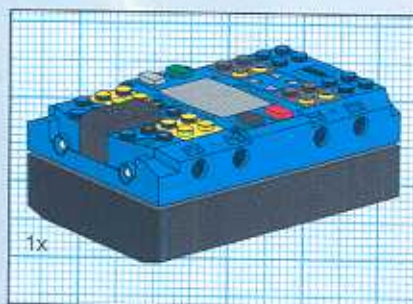

Your bug is now fully operational!

You can add the eyes and wings shown on the next pages, or skip to Explorations on page 34.

Checkpoint 6: Testing Your Bug's Feelers

1. Make sure the Scout is turned on.
2. Press the left side of the feelers.
The light next to port 1 should turn on.
3. Press the right side of the feelers.
The light next to port 2 should turn on.



Hint...

If the feelers do not work, review the building instructions for the feelers.

Checkpoint 7: Testing Your Bug's Drive

1. Place your Bug on a smooth floor.
2. Make sure the Scout is turned on.
3. Use Select and Change to set the Motion to Forward.
See page 8 for more information.
4. Press Run.
Your Bug should move forward.
5. Press Run to stop.



If your Bug turned or backed up, make sure the wires are connected to the Scout and motors as shown in the building instructions.

17

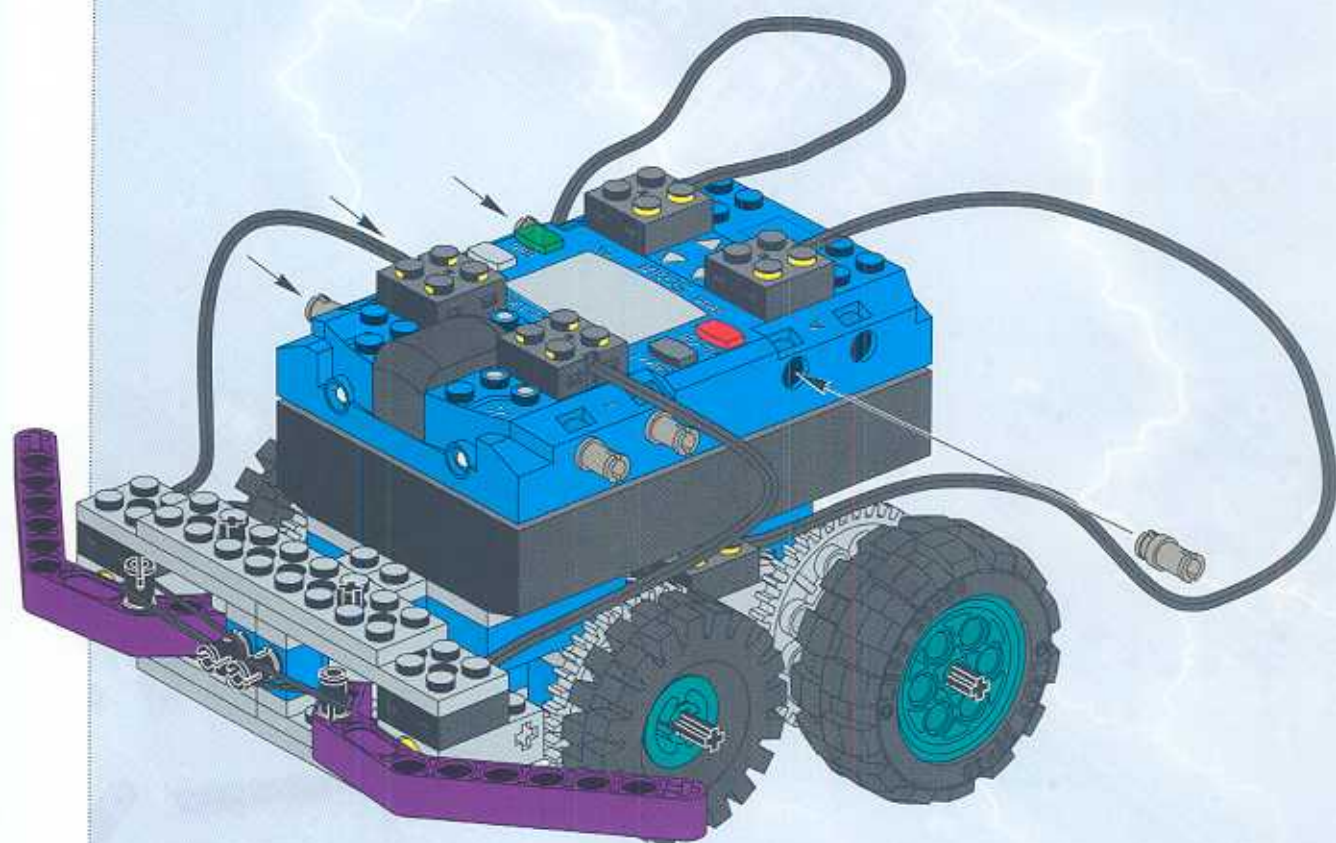



19

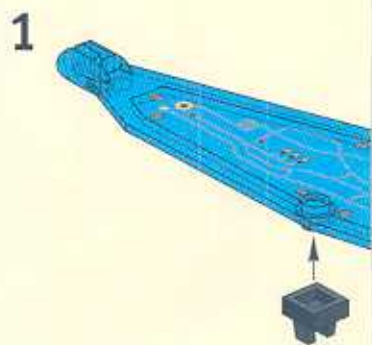
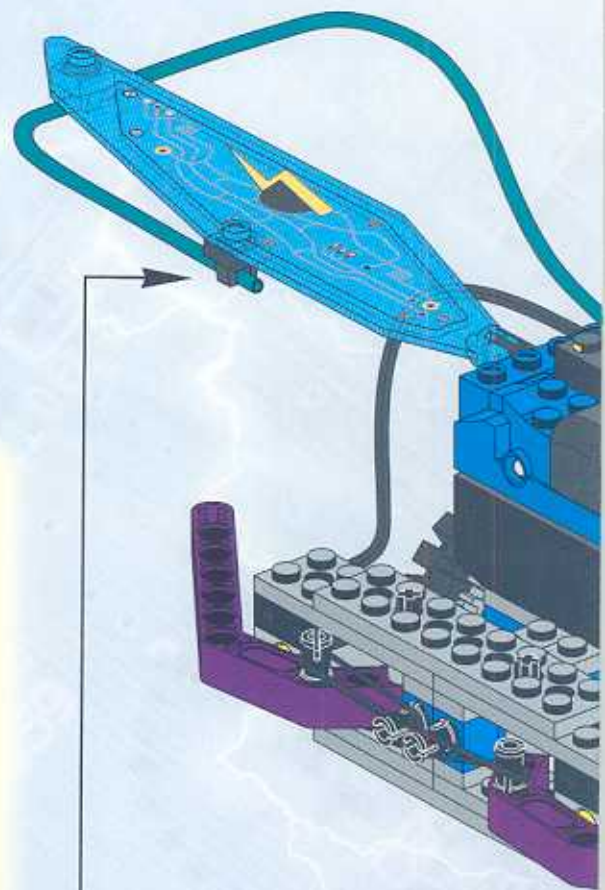
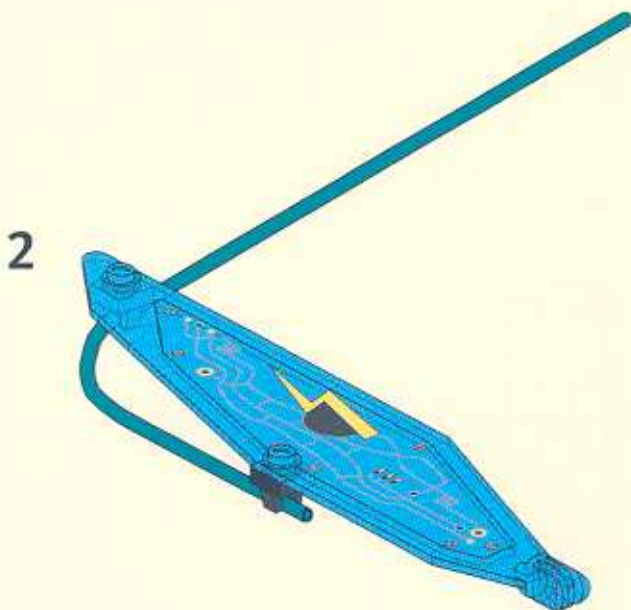
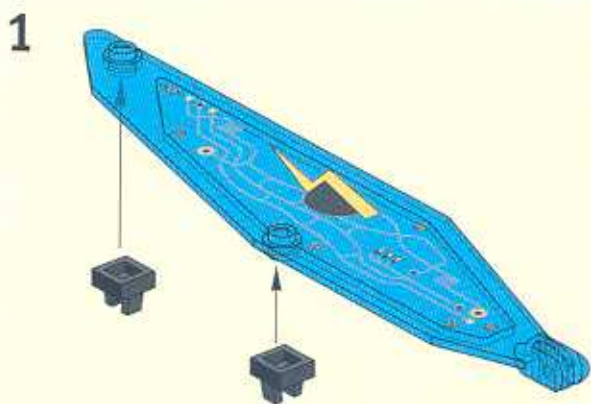
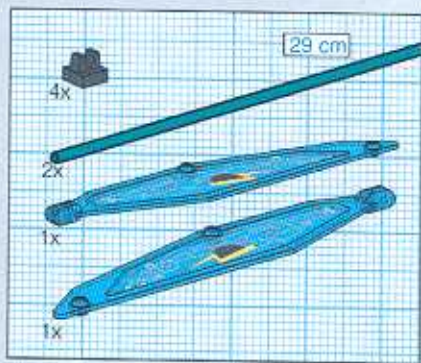

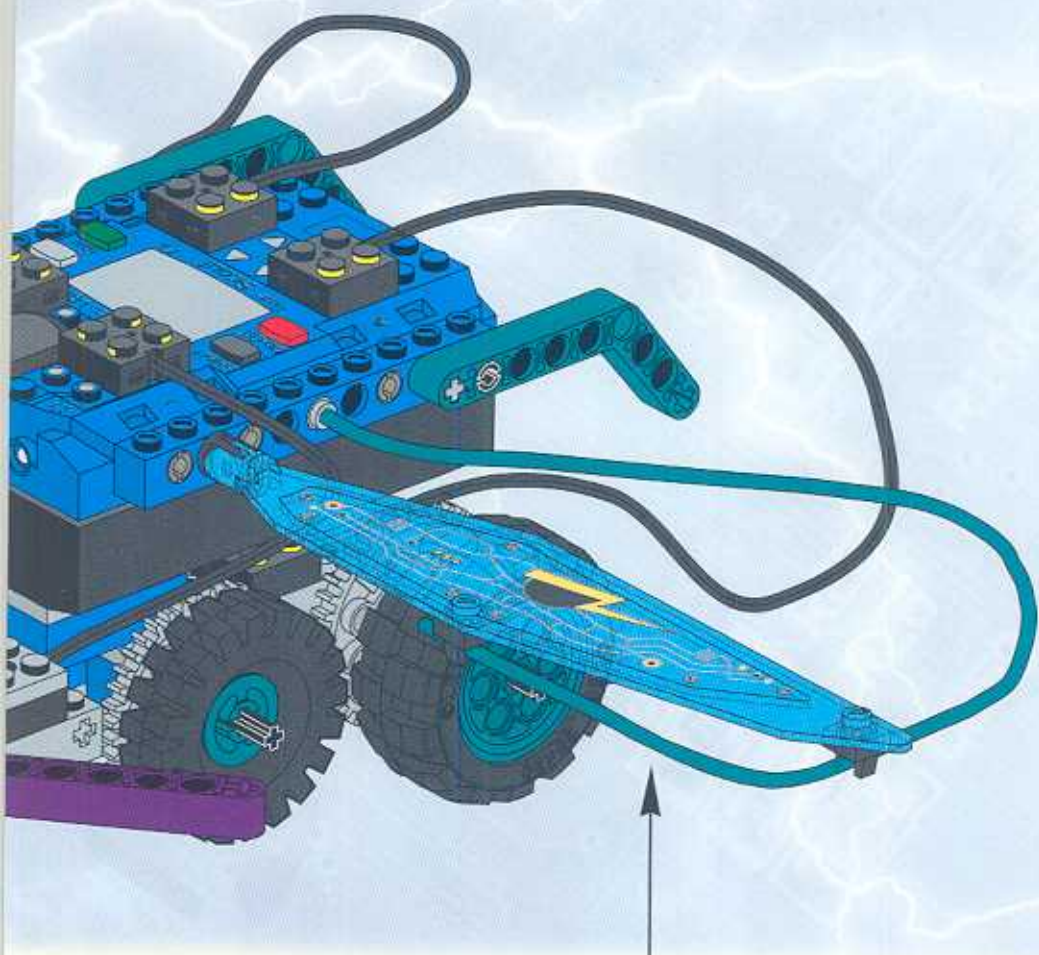

2

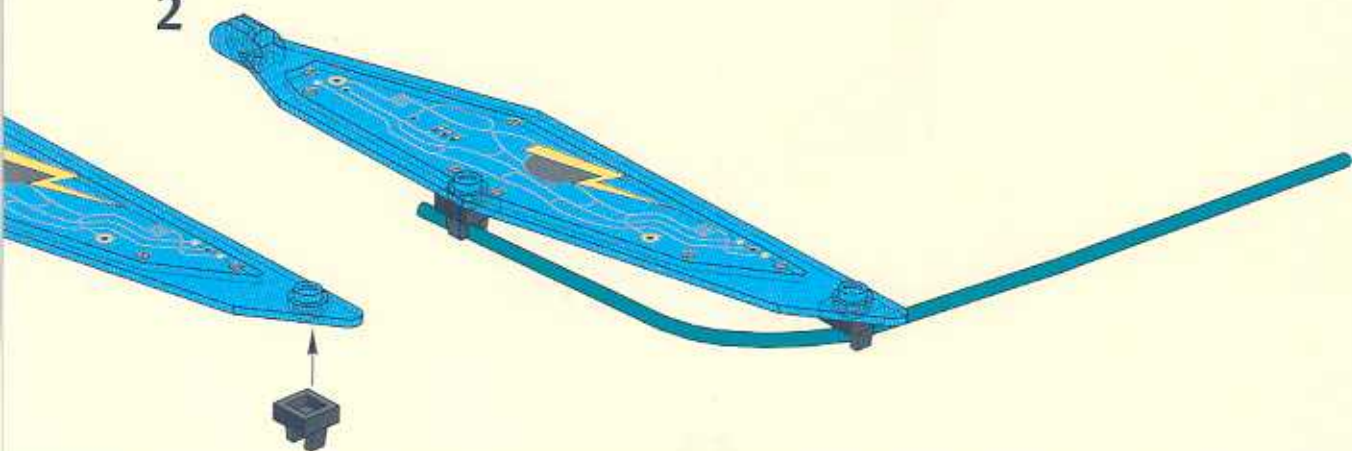

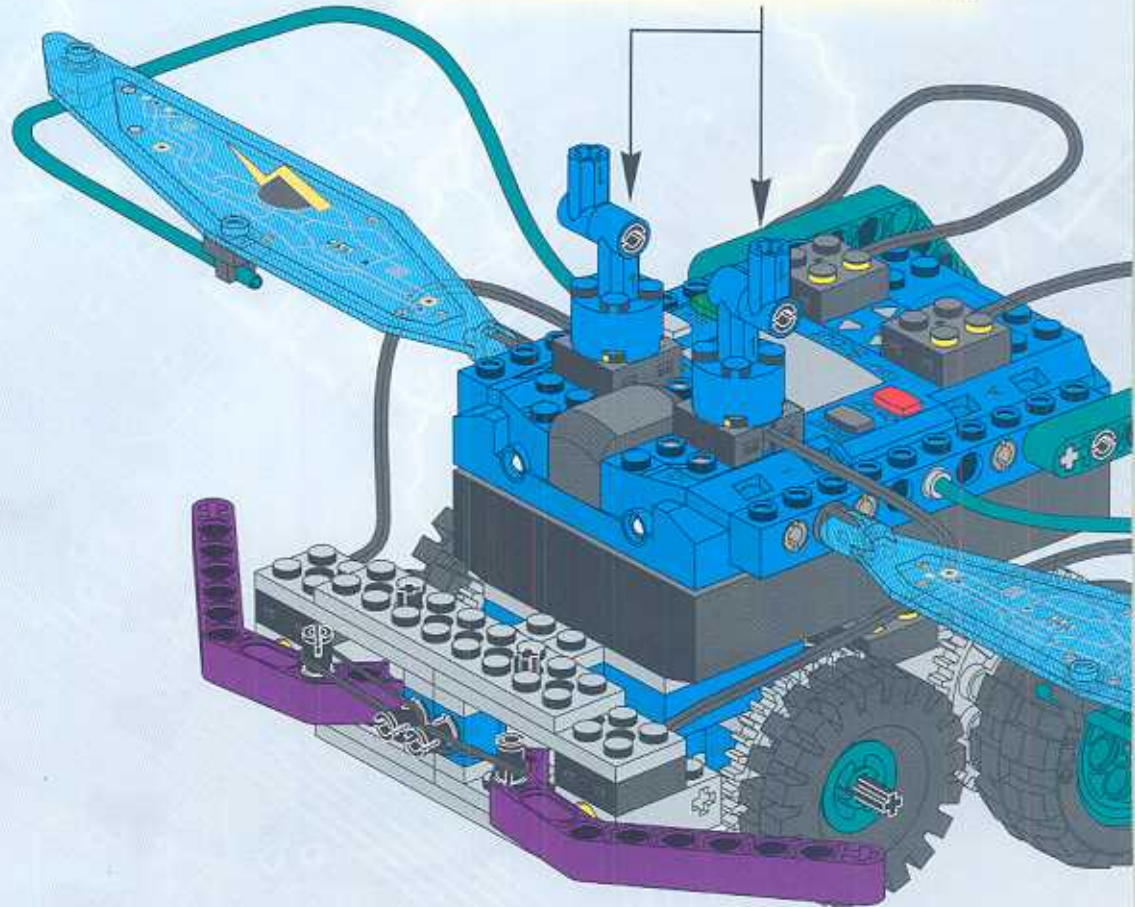
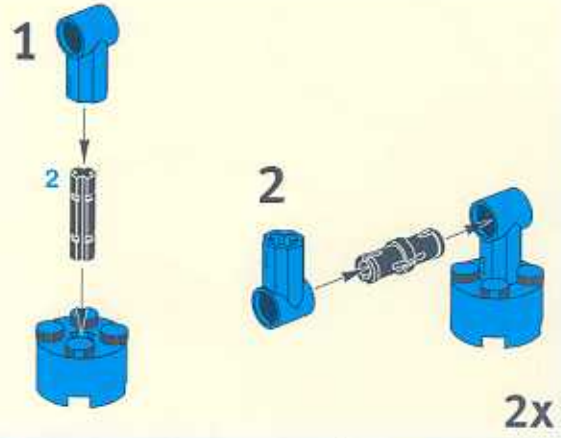

INTRODUCTION

GETTING STARTED

BUILDING INSTRUCTIONS

EXPLORATIONS

CHALLENGES

EXTRAS

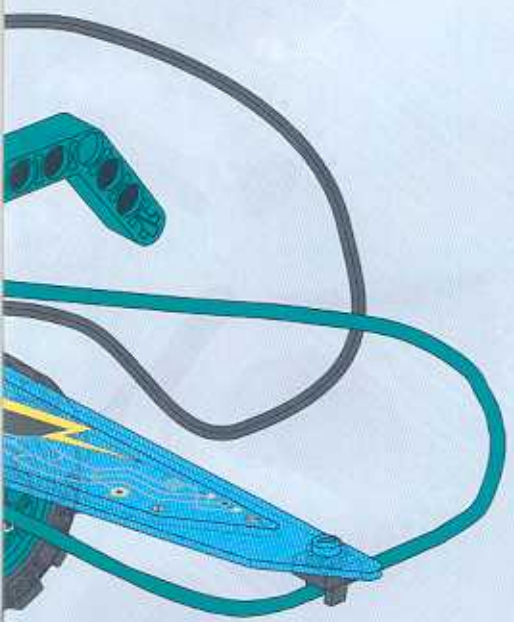

21

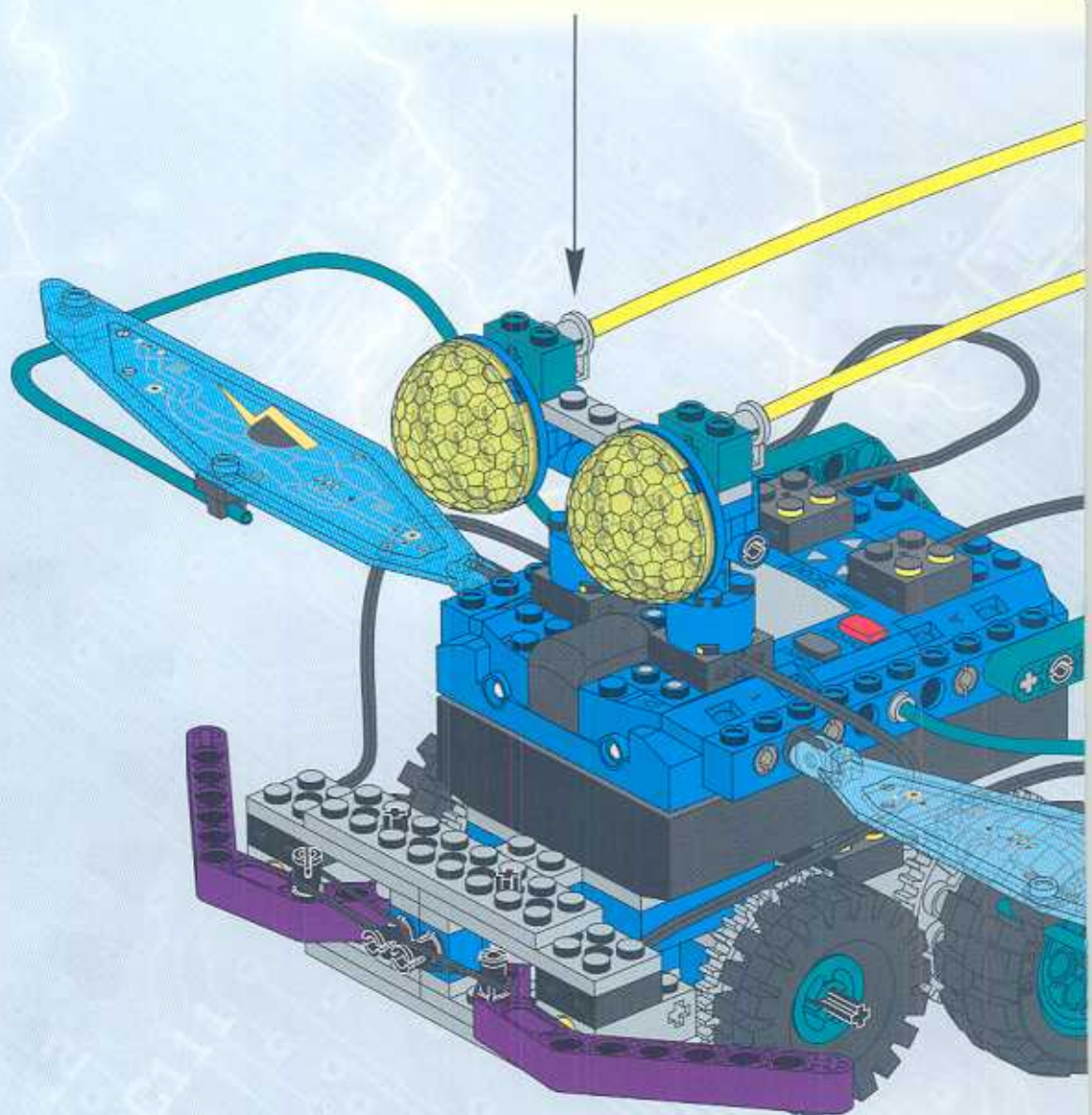
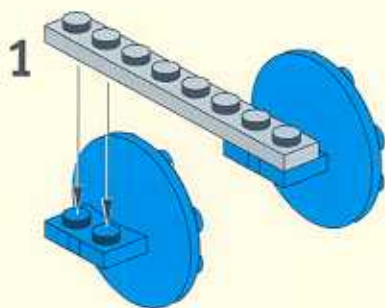
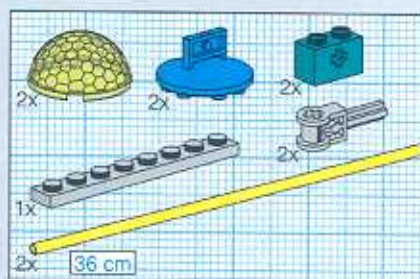

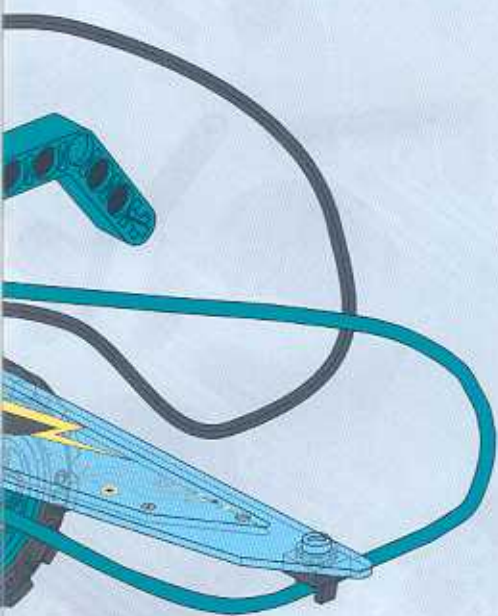
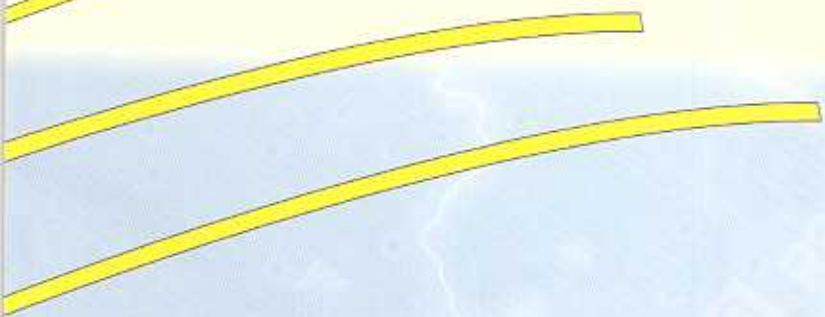
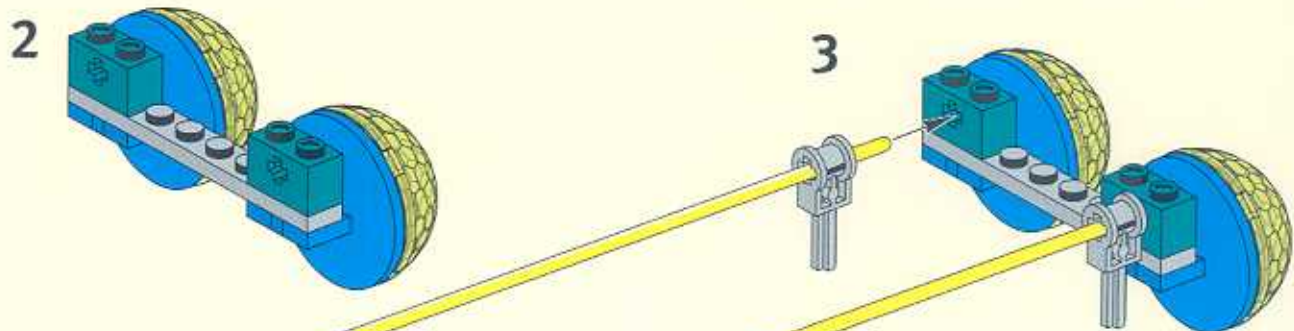



EXPLORATIONS

Part 1 – Making your Bug Move

Part 2 – Making your Bug Feel

Part 3 – Making your Bug See

Part 4 – Speeding up your Bug

Part 5 – Adding Special Effects

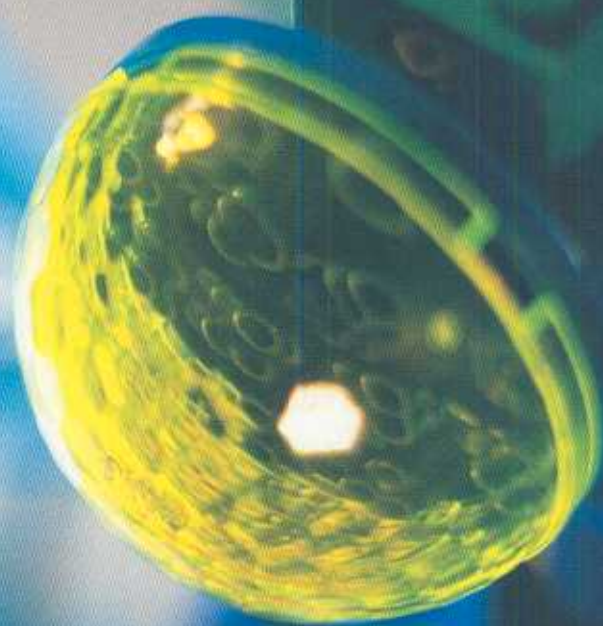

The Bug

In this section, you will start training your Bug to do many different tricks, such as:

- react to objects it feels
- run away from light (you know how some bugs hate the light)
- make different kinds of sounds
- and with a little help, even walk with legs

Once you have the basics down, try some of the challenges, and see how far you can take your invention.

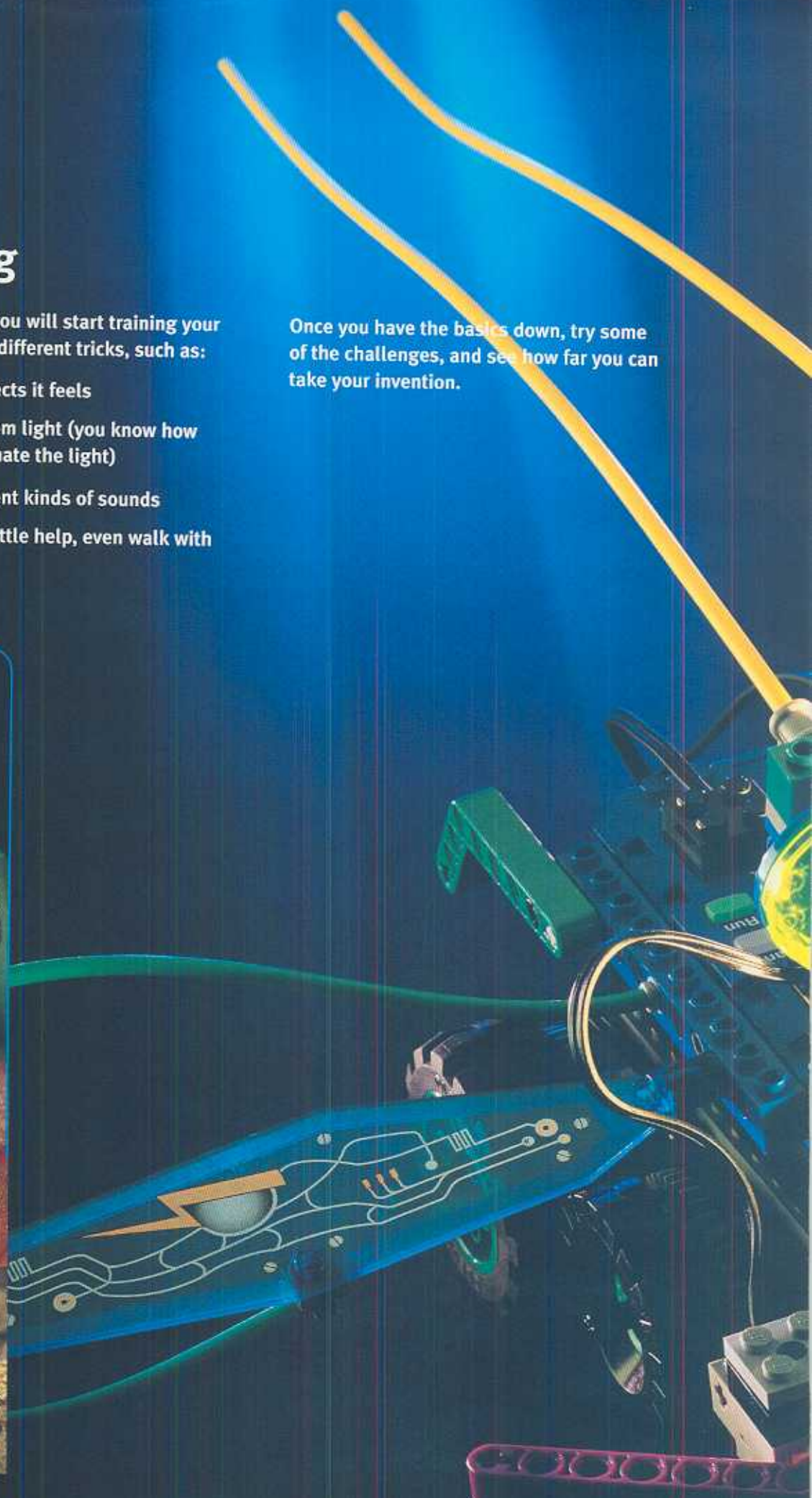

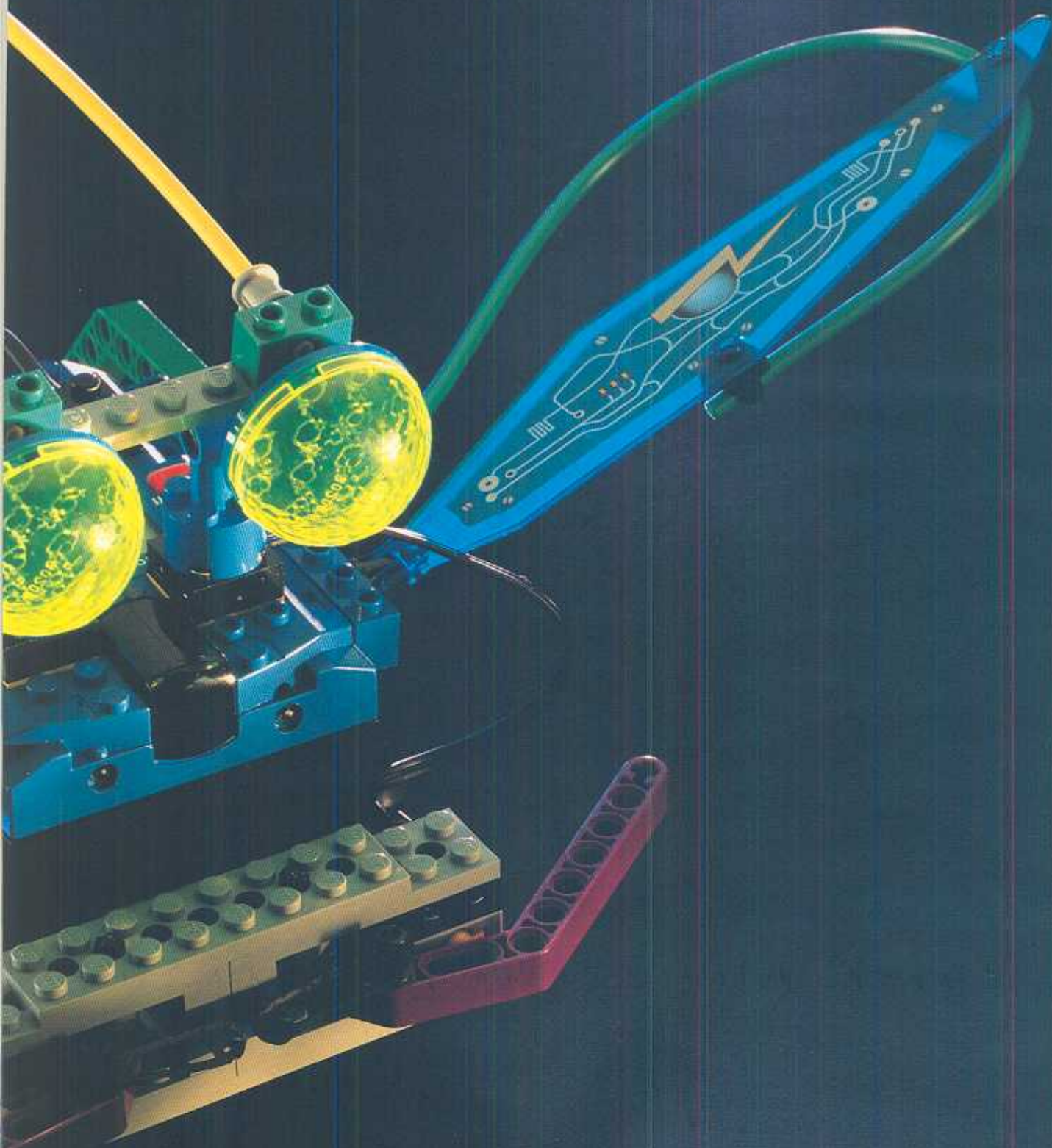

INTRODUCTION

GETTING STARTED

BUILDING INSTRUCTIONS

EXPLORATIONS

CHALLENGES

EXTRAS

FORWARD

The Motion commands tell your Bug how to move.

The Forward command in the Motion group will make your Bug move forward. Try it out.

1. Press the On-Off button to turn the Scout on.

Your Bug is now ready to go.

2. Use the Select and Change buttons to set the Scout's Motion to Forward.

Your display should look just like the picture. If it does not, see page 8 or hold down the On-Off button to reset the Scout.

3. Press the Run button to make the Scout move.

4. Press the Run button again to make the Scout stop.

More Motion Commands

Use Change to try the following Motion commands:

- ZigZag
- Circle
- Loop

(The Loop commands work better for robots you build in the Hoop-o-bot Book).



REVERSE

The Touch commands let your Bug know what to do when something touches its purple feelers.

The Reverse command in the Touch group tells your Bug to change the direction of its motors.

1. Set Motion to Forward.

Most of the time, it's a good idea to set the Motion to Forward when trying out new commands in other columns.

2. Set Touch to Reverse.

You have now told your Bug what to do when the touch sensors are pressed.

3. Press Run to start.
4. Press a purple feeler to activate a touch sensor.
5. Press either feeler several times to make your Bug go back and forth.
6. Press Run to stop.



AVOID

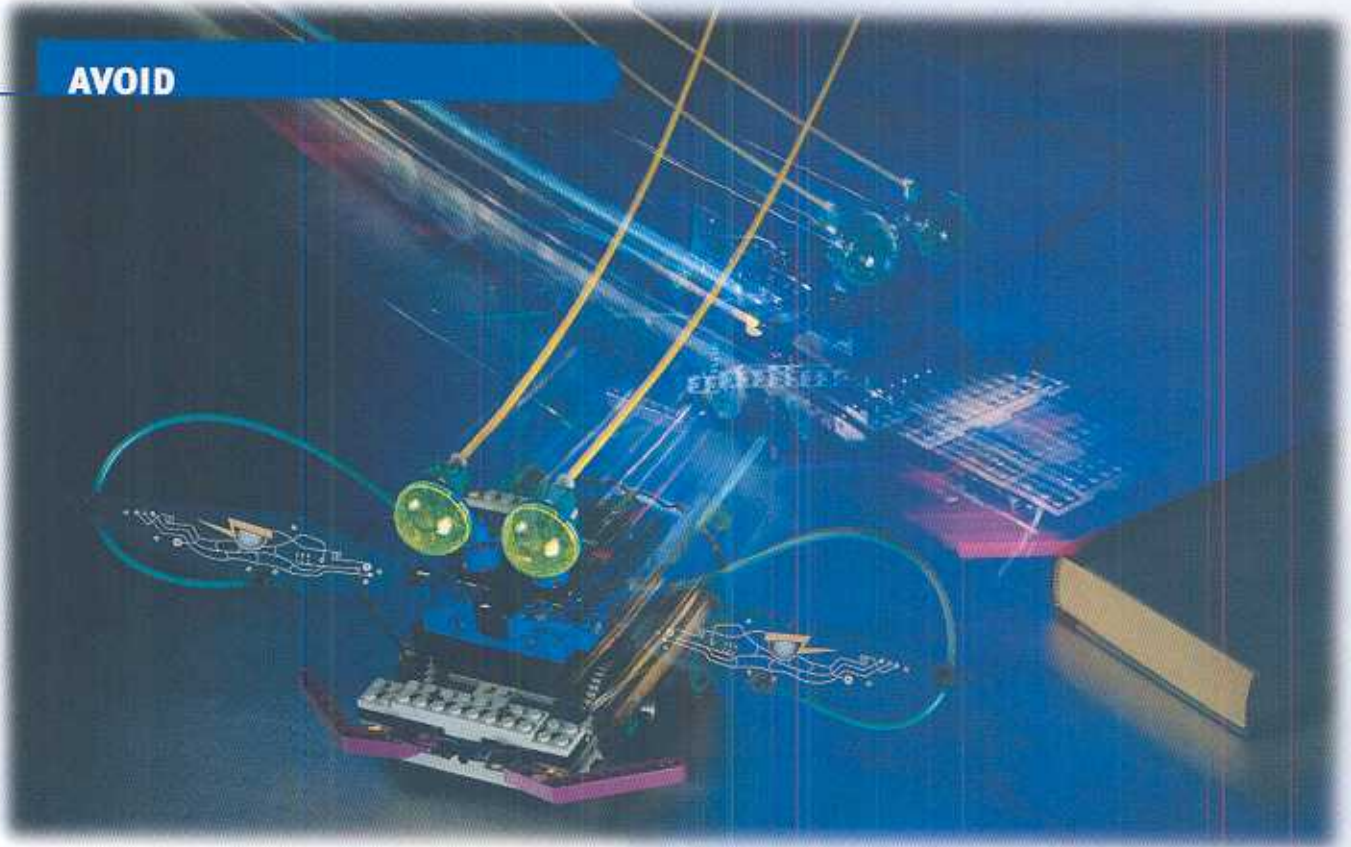

The Avoid command in the Touch group tells your Bug to back up, turn away and continue forward when its feelers are touched.

1. Set Motion to Forward.
2. Set Touch to Avoid.
3. Press Run.
4. Put your hand in your Bug's path and watch what happens when a purple feeler bumps into it.

Your Bug should back up and turn away.

5. Press the left feeler, then press the right feeler.

Watch how your Bug reacts each time.

6. Press Run to stop.



WAITFOR

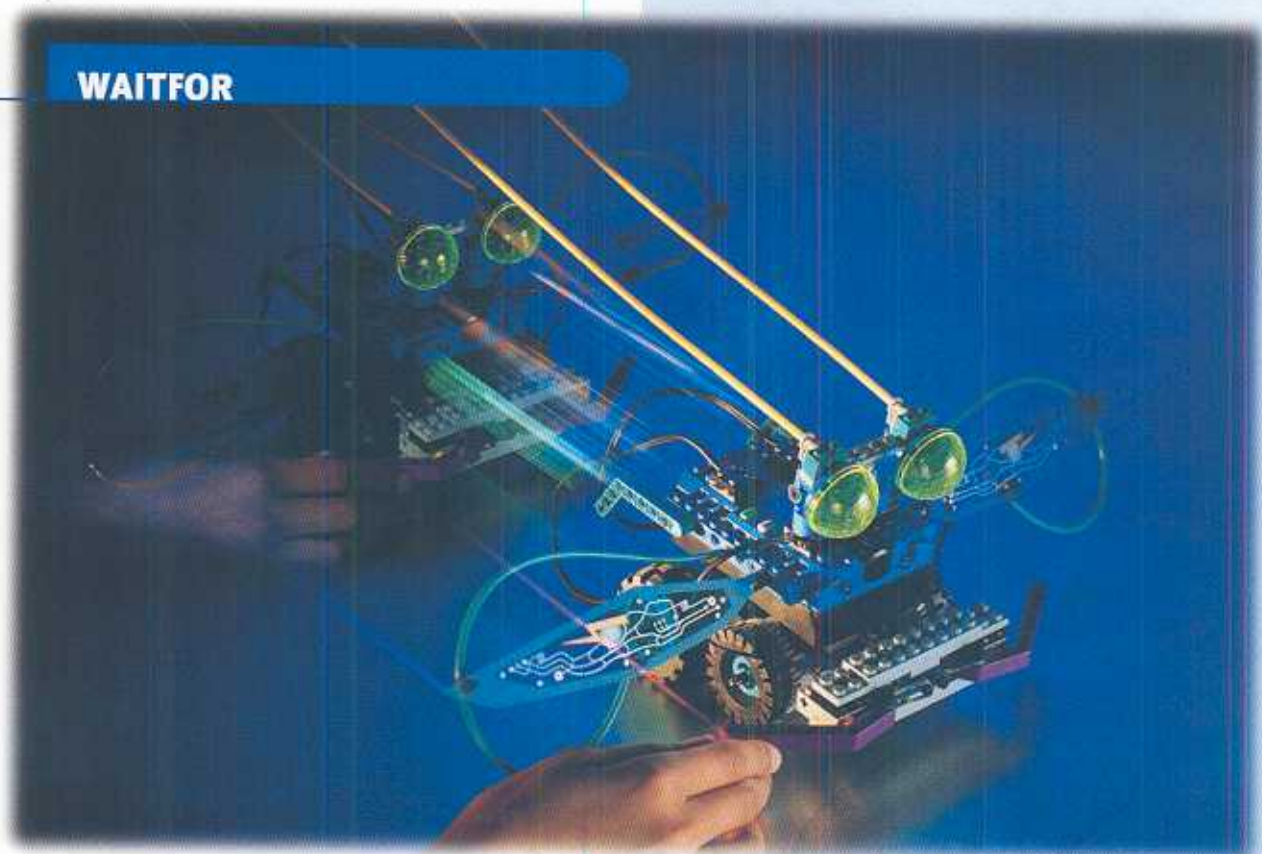

The WaitFor command in the Touch group tells your Bug to wait for something to touch its feelers before it moves.

1. Set Motion to Forward

2. Set Touch to WaitFor.

3. Press Run.

Your Bug now awaits your touch.

4. Press one of the feelers to activate a touch sensor.

Your Bug should start moving.

5. Press the feelers several more times.

Your Bug should start and stop with each press of a feeler.

6. When you're done, press Run to stop.



BRAKE



The Brake command in the Touch group turns off the motors when the feelers are touched. It acts like a brake on each side of the Bug.

1. Set Motion to Forward
2. Set Touch to Brake.
3. Press Run.
4. Press both feelers at once to turn both motors off.

This is a little like pressing the hand brakes on a bicycle.

5. Press one feeler at a time.
6. Press Run to stop.



SEEK ☀

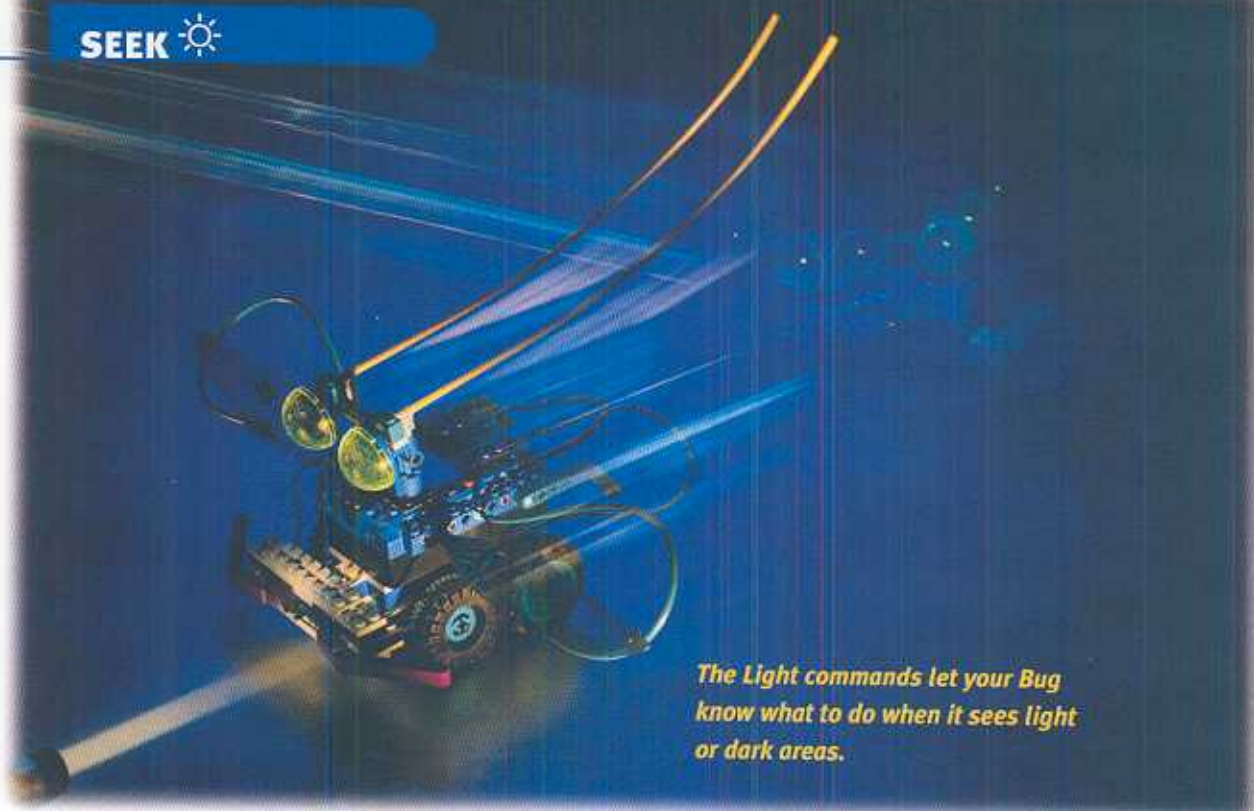

The Light commands let your Bug know what to do when it sees light or dark areas.

The Seek ☀ command makes your Bug stop, spin around and point towards the brightest source of light it sees.

1. Set Motion to Forward and Light to Seek ☀.
2. Put your Bug on the floor in a room that has a single light source, such as a room with a bright window or lamp.
3. Press Run.
4. Watch how your Bug moves.
If it can see the light it should drive towards it.
5. Press Run to stop.

Hint....

For best results, find a dark room. Use a flashlight to see if you can make your Bug follow you.

More Light Commands

Use Change to try Seek ☹ and other Light commands.



TIME DOTS

The Time settings let you change how long other commands take to run.

The Time Dots set how long your Scout's motors stay on. The more dots you choose, the longer the time.

1. Set Motion to ZigZag.

A Zig is a step in one direction. A Zag is a step in the other direction.

2. Press Select until the Time Dots flash.

3. Choose one dot for a short Zig and Zag.

4. Press Run.

Your Bug should make very short Zigs and Zags, almost like it's dancing.

5. Press Run to stop.

To change to a long Zig and Zag, use Select and Change to choose three dots.



BUG FX (EFFECTS)

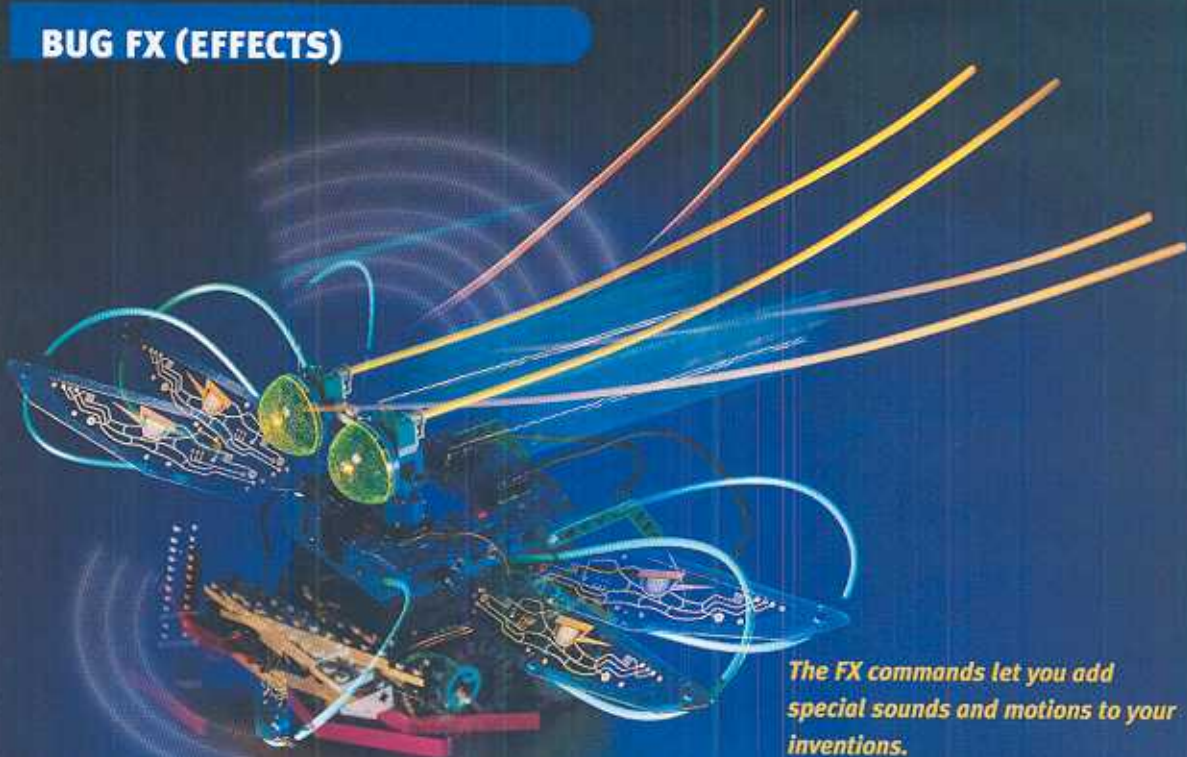

The FX commands let you add special sounds and motions to your inventions.

You can use FX to make the Scout sound and move like a bug.

1. Set Motion to Forward.
2. Set Touch to Avoid.
3. Use Select to choose the FX symbols.
4. Press Change until the  symbol flashes.
5. Your Bug will make new sounds, and do a bug dance every few seconds.
6. Press Run and watch the reaction.
7. Press Run to stop.

Hint...

You can select the other FX symbols to see what they do. Check out Technical Stuff under Extras for more details.





CHALLENGES AND EXTRAS

Special Features

Tips & Tricks

Frequently Asked Questions

Technical Stuff



1: DRIVING PATTERNS

Try to get your Bug to move in different patterns on the floor.

- 💡 Make your Bug drive in a large circle or do a little dance.
- 💡 Make your Bug explore your room without getting stuck.

You may need to pull off its wings and eyes for this trick.

- 💡 Make your Bug march back and forth in front of your door like a guard dog.

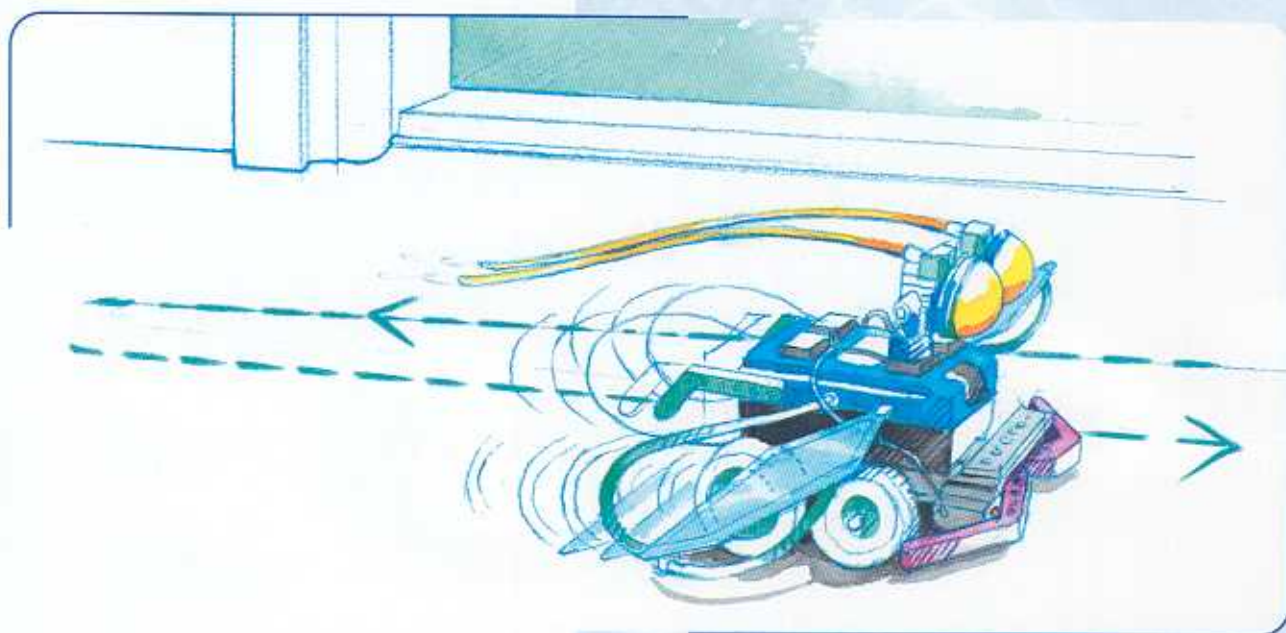

Experiments...

To help make your Bug turn, put objects like books and LEGO buildings in its path. Use the Touch commands to change the direction of your Bug.

Hint....

If your Bug doesn't do what you want, try a different command. To reset your Bug, hold down the On-Off button for 2 seconds.

2: CHALLENGE WITH FEELING

Try to get your Bug to go through an obstacle course.

- 💡 Design an obstacle course for your Bug using books, boxes, or LEGO buildings.
- 💡 See if you can teach your Bug to find its way from start to finish.
- 💡 Now try to get your Bug to go through the course by using its Light commands and a flashlight.

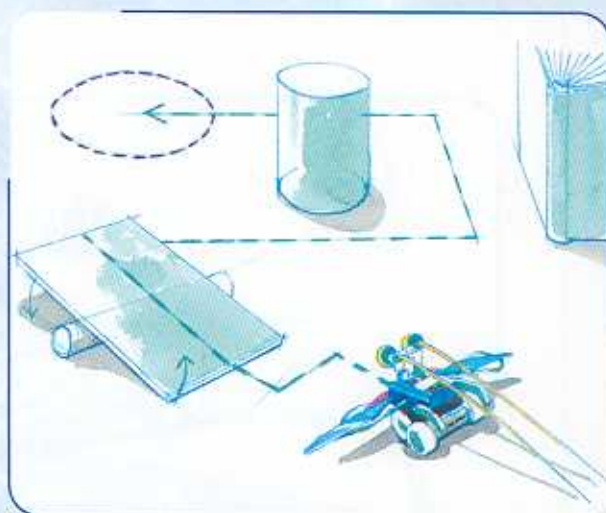
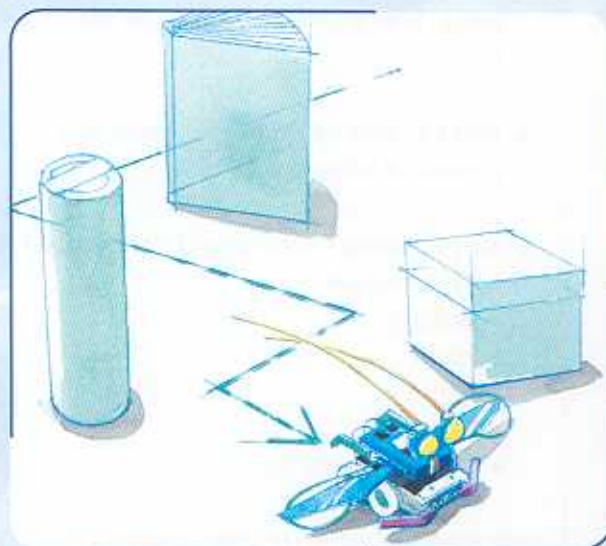

Experiments...

1. Try to change your Bug's feelers to touch from further away.
2. Try making your obstacle course more challenging by:
 - Making it longer.
 - Adding more turns.
 - Adding more lights.
 - Putting things for your Bug to climb over.

Hint....

See the section on Special Features for some ideas on designing touch feelers.

3: BUILD YOUR OWN BUG

1. Design your own creature. Change how it looks, how it uses its feelers, or even how it drives.
2. Make a creature that walks using legs instead of wheels.
3. Try combining the commands you've used so far in new ways:
 - Motion
 - Touch
 - Light
 - Time
 - FX (special effects)

Use them to customize your creature's behavior.

Walker-bot

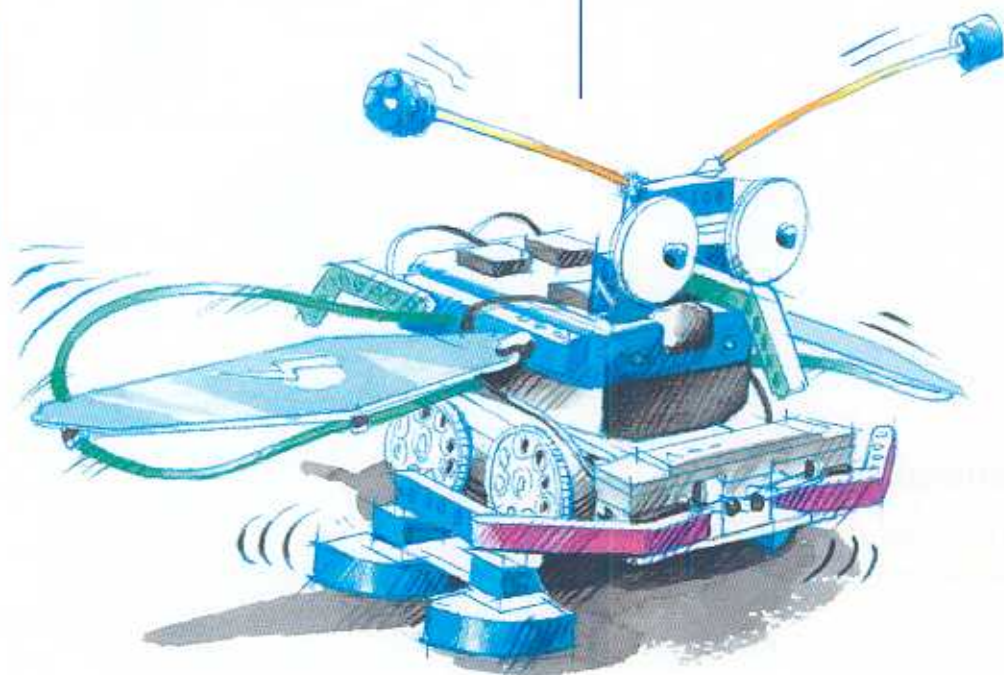

Hint....

See the section on Special Features for some ideas.

Battle Beetle

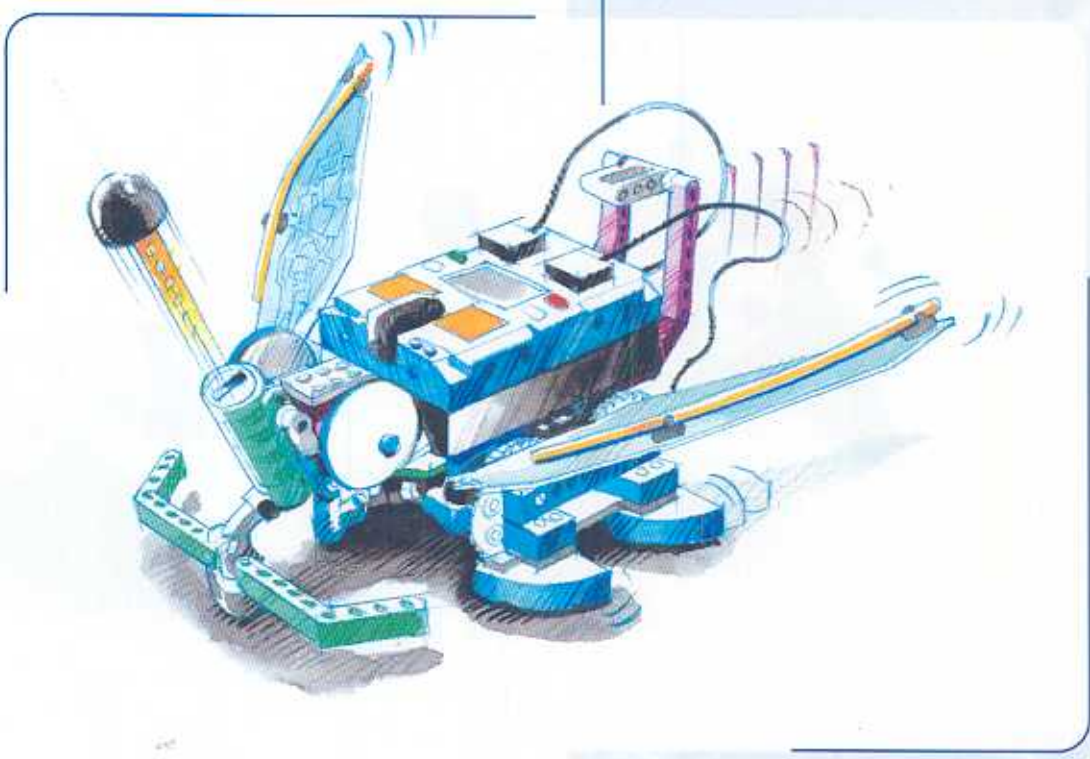

Happy faced Feeler

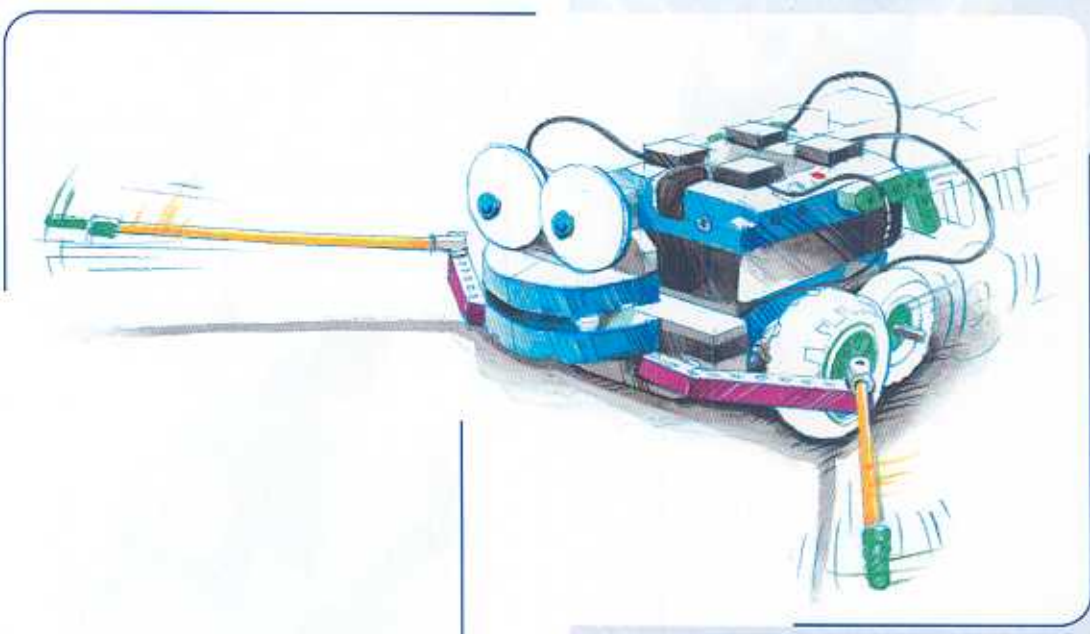

Here are some ideas for changing how your Bug looks.

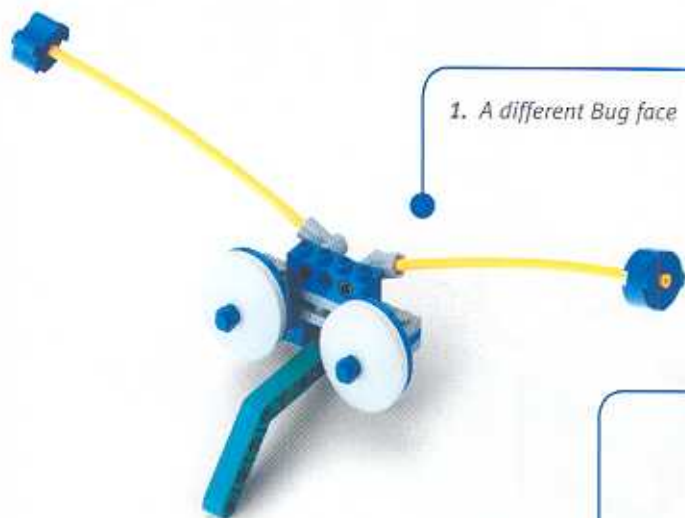

1. A different Bug face



2. A Dog



3. Happy face



4. Launcher head

5. Feelers to add on



6. Wings



7. Add legs instead of wheels.
Look at page 53 for building instructions.

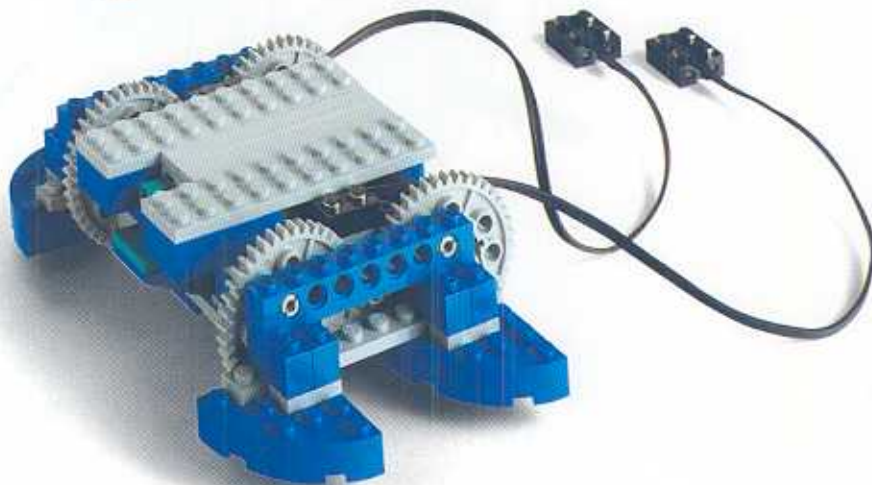

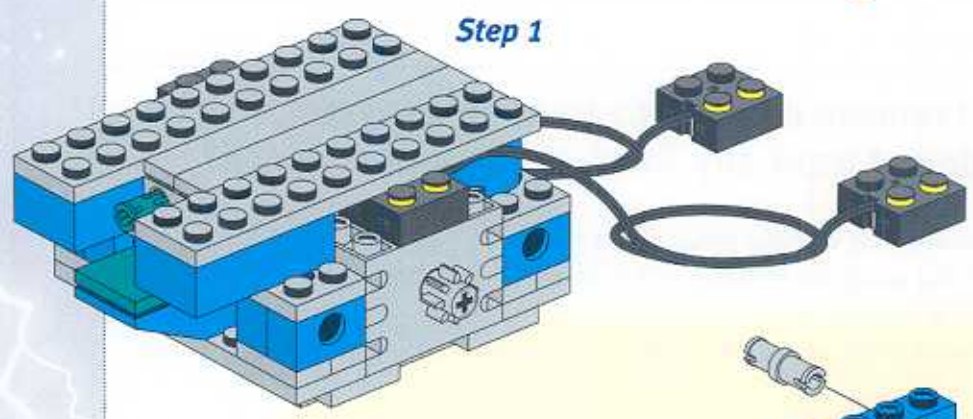

Step 1

Build steps 1-6 in the building instructions. Then remove the axles.

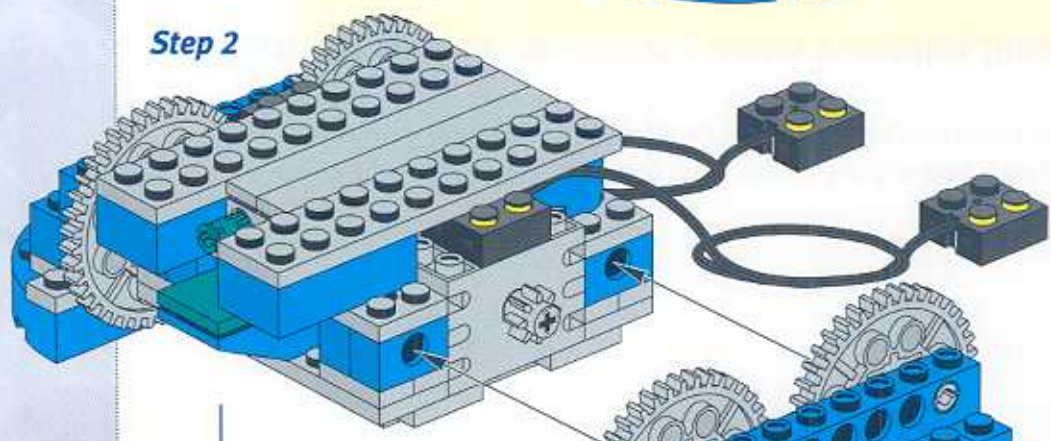
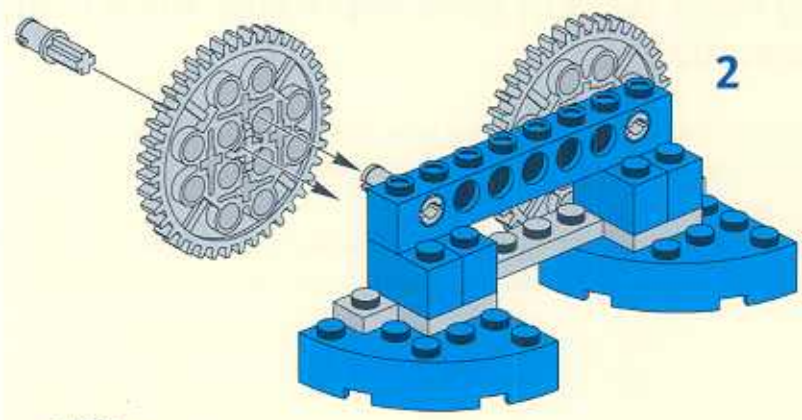
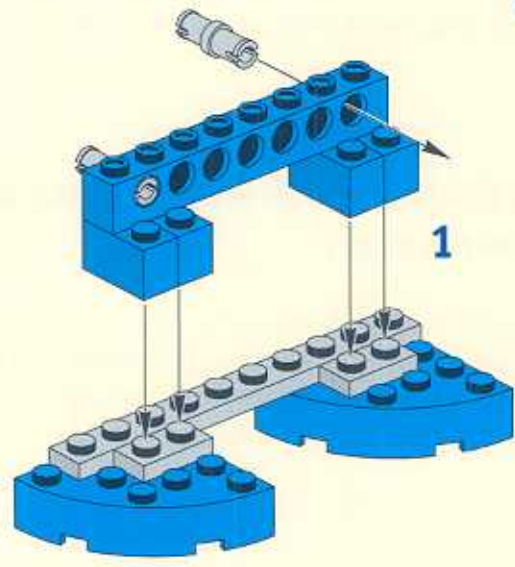

Step 2

Add legs the same way on the other side.

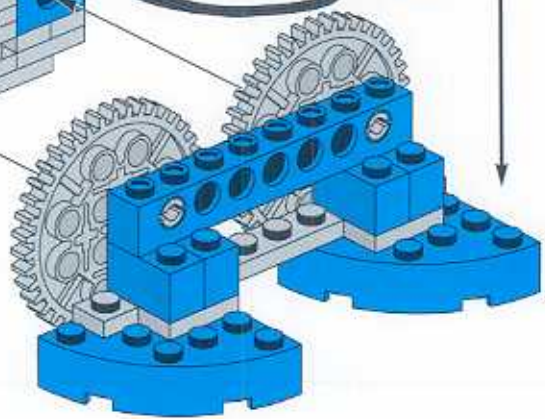

1. **How do I remove commands from my program, like when I do not want any Touch or Light commands?**

To clear the commands within a group, press the Change button until all of the commands in the group are flashing. (This means the group is selected, but no one command is active).

When you press Run or Select, the commands in that group will disappear.

2. **Is there a quick way to clear all the commands from the display?**

You can reset the Scout to the original "Forward only" program using the On-Off button. While the Scout is on, hold down the On-Off button for two seconds. The Scout should beep and the display should have the Forward command flashing, two time dots, and the other groups clear.

3. **My robot turns or goes backwards when it should go forward.**

The motors spin in different directions depending on how you connect the wires. Make sure that the wires are attached to the motors and the Scout correctly. (See page 5 of the Bug Book.)

If you are still having problems, try running a simple command like Forward to check your motor directions. (See Checkpoint 7 in the Bug Book for more help.)

4. **Nothing happens when I press the touch sensors.**

Check to make sure that the wires are attached to the touch sensors and the yellow touch sensor ports on the Scout correctly. (See page 6 of the Bug Book.)

5.

Sometimes when I point a light at the Scout, it does not see it.

Make sure that you point the light directly at the Scout's light sensor. (See page 7 of the Bug Book.) Also, try pressing the On-Off or Run buttons before you shine a light on the light sensor. This lets the Scout readjust its "eye" to see the difference between dark and bright.

6.

I have been trying out different programs, but do not understand what some of the commands are supposed to do.

For a quick explanation of the commands, see next page. Also, when experimenting with new commands, set the Motion group to Forward and then try adding only one new command at a time.

7.

What is Power Mode (⚡), and how do I get out of it?

Power Mode lets the Scout do more programs beyond the commands that are on the display. To use Power Mode, you will need to have a Scout Booster Set, which will be available in late 2000.

If you get stuck in Power Mode (i.e. you only see the ⚡ symbol,) press the Change button once to get back to normal Scout Mode.

8.

Can the Scout work with any other products from LEGO MindStorms?

The Scout works with the LEGO MindStorms Remote Control and the RCX (both sold separately).

The Remote Control is a wireless hand-held controller. It lets you control the motors as well as start and stop programs from up to several meters away. For more advanced users, the Scout can also take commands from the RCX (another LEGO microcomputer that is sold as part of the Robotics Invention System). This lets you do things like make one robot control another robot, or make one big robot that uses multiple Scout and RCX bricks. For this function, you'll need to program the RCX to send an IR Message (1 through 12) using RCX Code. The Scout will respond to the IR Messages while it is running any program on the display.



For more information on these topics, check out www.legomindstorms.com.

The Scout

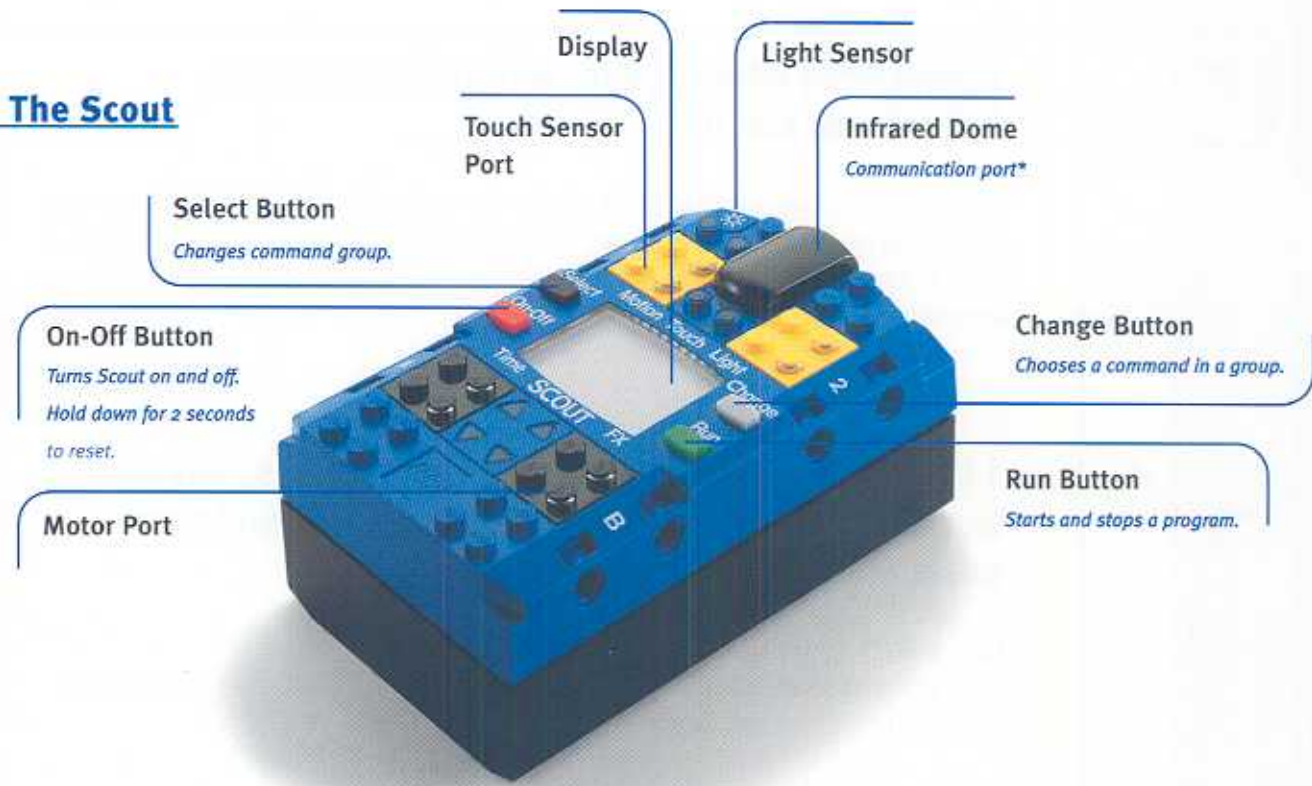

Display

Motion Touch Light

<p>Forward <i>Moves motors forward</i></p>	<p>Reverse <i>Changes direction of motors</i></p>	<p>Seek ☀️ <i>Looks for light or dark</i></p>
<p>ZigZag <i>Moves in a Zig Zag pattern</i></p>	<p>Avoid <i>Backs up and turns away when touched</i></p>	<p>Avoid <i>Backs up and turns away when it sees light or dark</i></p>
<p>Circle ↻ <i>Moves in a circle to the right or left</i></p>	<p>WaitFor <i>Waits for a touch before it moves</i></p>	<p>WaitFor <i>Waits for light or dark before moving</i></p>
<p>LoopAB <i>Runs motors A and B back and forth in different patterns</i></p>	<p>Brake <i>Turns off motors when touched</i></p>	<p>Brake <i>Turns off motors when it sees light or dark</i></p>
<p>○○○ <i>Changes how long the other commands take to run</i></p>	<p>⚡ Power Mode</p>	<p>🐛 🔊 ? ⚡ Bug Mode Alarm Sounds Random Movements Geiger Counter</p>
<p><i>Special effects that add sounds and movements</i></p>		

Time SCOUT FX

* Check out www.legomindstorms.com for more information

