



Harry Potter

76444





LEGO.com/sustainable-packaging



FR  
**DONNEZ**  
OU  
**RECYCLEZ**



ASSOCIATION

OU



MAGASIN

OU



DÉCHÈTERIE

Adresses sur [quefairedemesdechets.fr](http://quefairedemesdechets.fr)



# BUILDER



Apple and the Apple logo are trademarks of Apple Inc., registered in the U.S. and other countries and regions. App Store is a service mark of Apple Inc. Google Play and the Google Play logo are trademarks of Google LLC. Tencent and the Tencent logo are trademarks of Tencent Inc.

LEGO.com/devicecheck



LEGO® Builder





# BIENVENUE SUR LE CHEMIN DE TRAVERSE LEGO®

Après avoir exploré le set LEGO® Le château et le domaine de Poudlard (76419), nous nous rendons maintenant dans un autre lieu enchanté du Monde des Sorciers : Le Chemin de Traverse. Ce set s'inspire de certaines des scènes les plus emblématiques de la série de films ; depuis le jour où Harry Potter™ pénètre dans le monde caché de la magie jusqu'à l'évasion épique du dragon Pansedever ukrainien de Gringotts™.

Pour connaître les sorts de construction appropriés pour ce modèle, notre équipe de conception s'est rendue chez Warner Bros. Visite des studios – La réalisation de Harry Potter™ à Londres et les nombreuses recherches effectuées pour chaque boutique du décor. C'était amusant de devoir trouver un juste milieu entre la précision et les enchantements colorés dans les 16 boutiques, et de créer un paysage urbain pour cette belle rue. Les 12 personnages parmi les plus appréciés et les plus redoutables des films vous permettent désormais de recréer l'effervescence magique que nous aimons tant dans le Chemin de Traverse !

*Yi-Chien Cheng, Senior Designer LEGO®*





# VOTRE GUIDE DU CHEMIN DE TRAVERSE™

Le Chaudron  
Baveur

Madame Guipure,  
prêt-à-porter pour  
mages et sorciers

Eeylops,  
au Royaume  
du Hibou

La boutique  
d'apothicaire de  
Mr Mulpepper

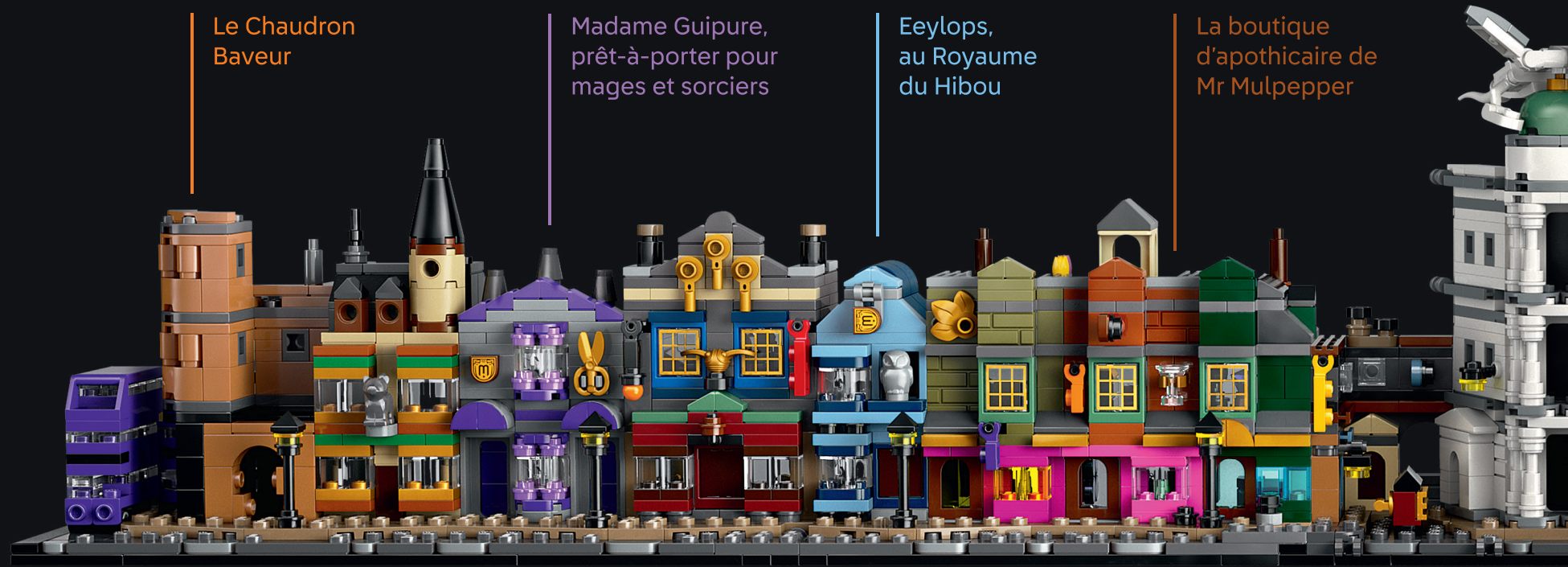

La Ménagerie  
magique

Le Magasin  
d'accessoires  
de Quidditch

La boutique  
de l'apothicaire

Au Bon  
Chaudron





La banque  
des sorciers  
Gringotts™

La boutique  
Scribbulus™  
Instruments  
d'écriture

Wisecacs,  
équipements  
pour sorciers

Fleury et Bott



Barjow et Beurk

Ollivander -  
Fabricants  
de baguettes  
magiques

Glaces  
Florian  
Fortarôme

Weasley,  
Farces pour  
sorciers  
facétieux





# BRIC-À-BRAC POUR TOUTE VOTRE MAGIE

Que vous soyez à la recherche de votre première baguette ou de petits-fours Tourndelœil bien frais pour réussir vos examens à Poudlard (ou en être dispensé(e)), les boutiques du Chemin de Traverse sont réputées pour leurs gadgets magiques dernier cri et leurs curiosités qui attirent les sorciers et les sorcières de tous âges. De la boutique séculaire de baguettes magiques d'Ollivander à celle de farces pour sorciers facétieux de Weasley, chaque boutique est imprégnée des riches traditions, de l'histoire et de la nostalgie du monde des sorciers.

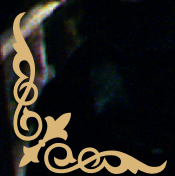





## JETEZ VOTRE SORT DE MÉTAMORPHOSE

Il ne vous reste plus qu'à jeter un sort de métamorphose sur les briques de cette boîte pour invoquer la devanture et l'intérieur confortable de chaque boutique, y compris le célèbre Magicobus. Le modèle étant composé de cinq sections distinctes, vous pouvez inviter vos amis sorciers, sorcières ou moldus à profiter de la magie de la construction à plusieurs. D'une longueur totale de 88 cm, le modèle peut également être plié pour recréer une vue classique du Chemin de Traverse avec la banque des sorciers Gringotts™ au centre.



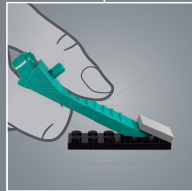
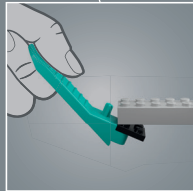
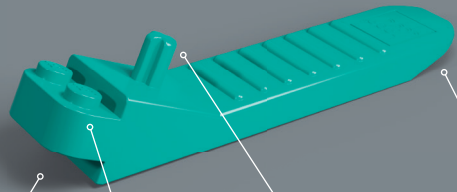

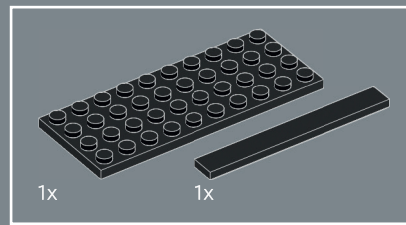

1

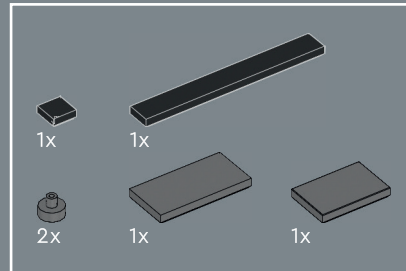
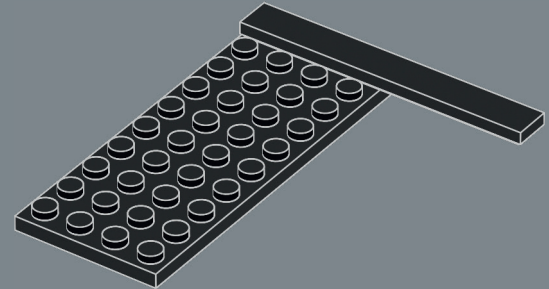

2

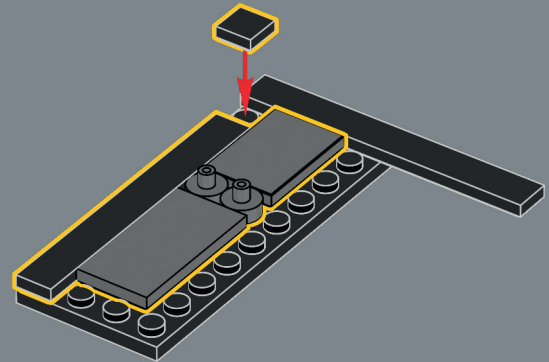

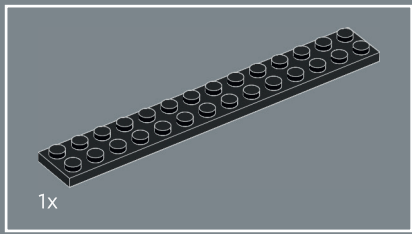

3

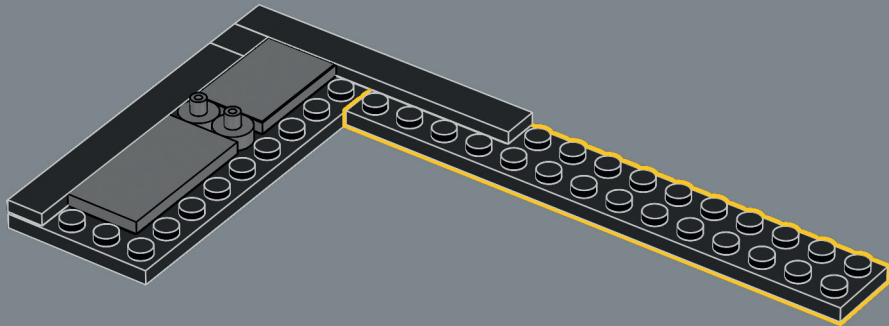

4

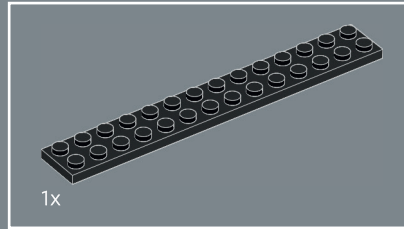
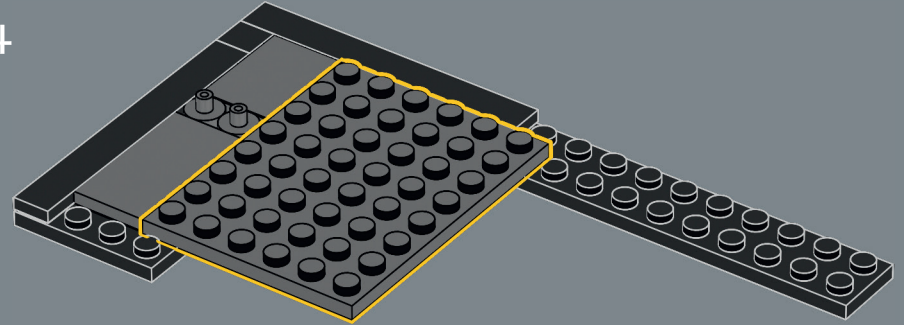

5

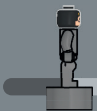
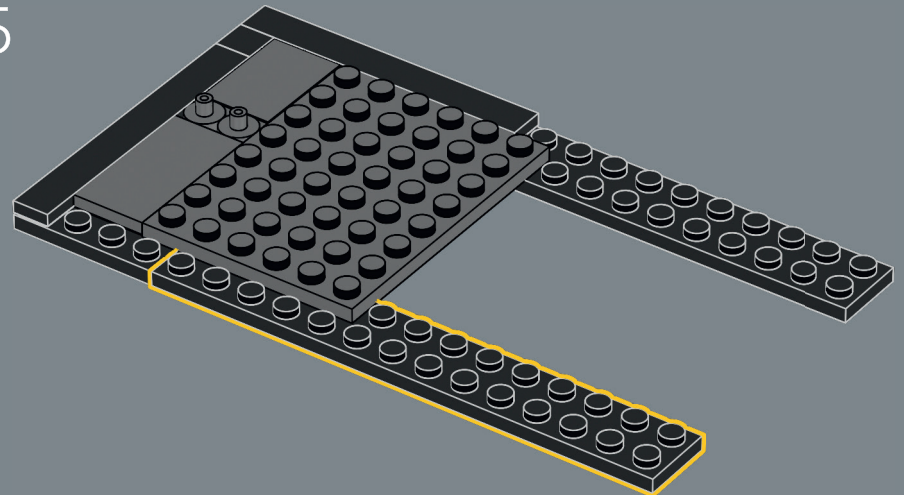

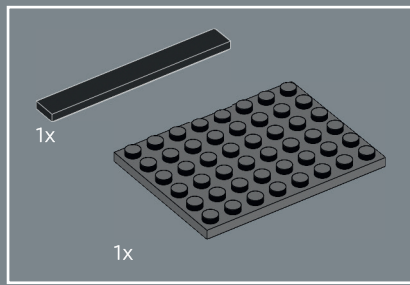

6

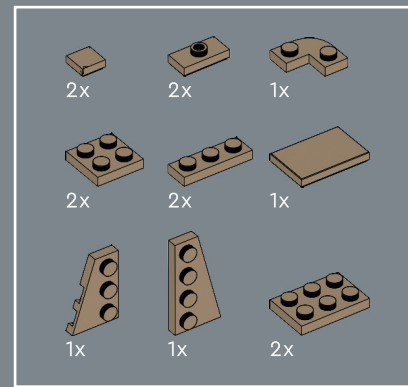
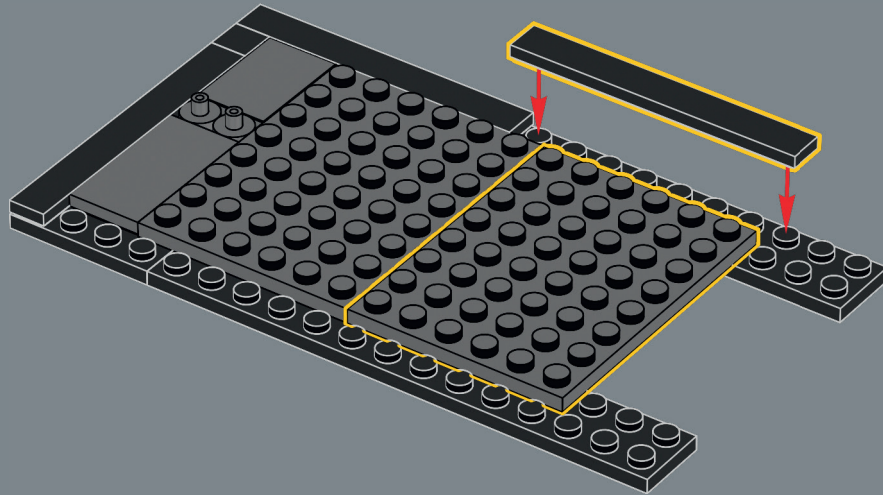

7

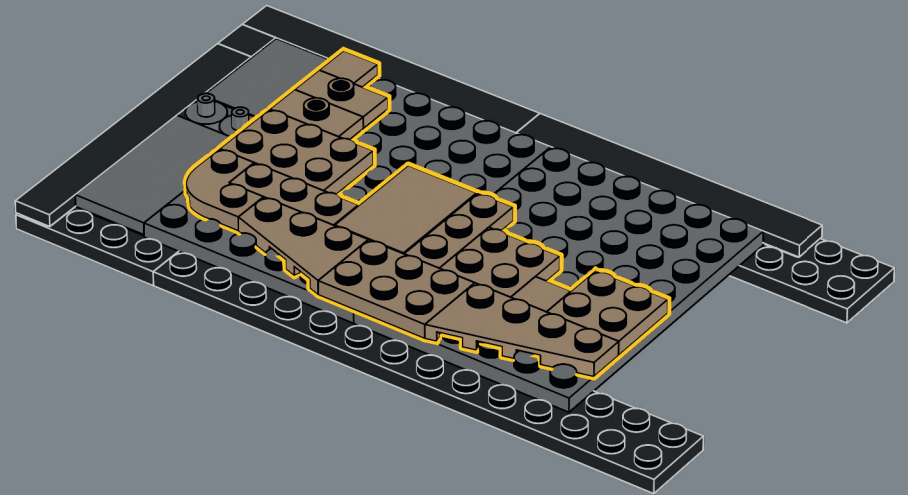

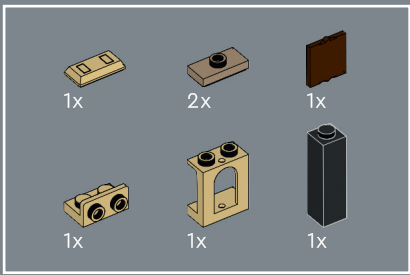

8

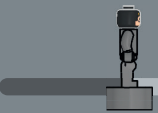
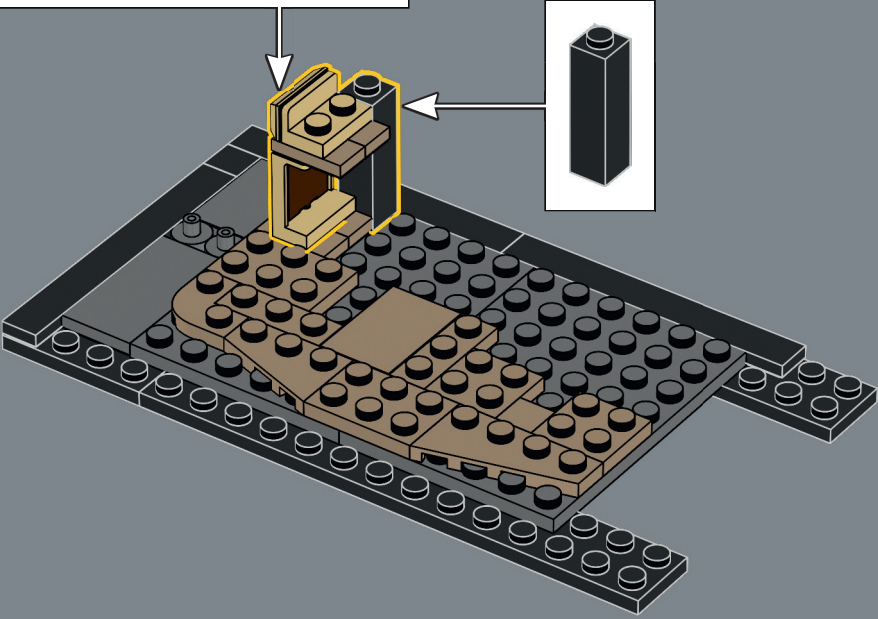
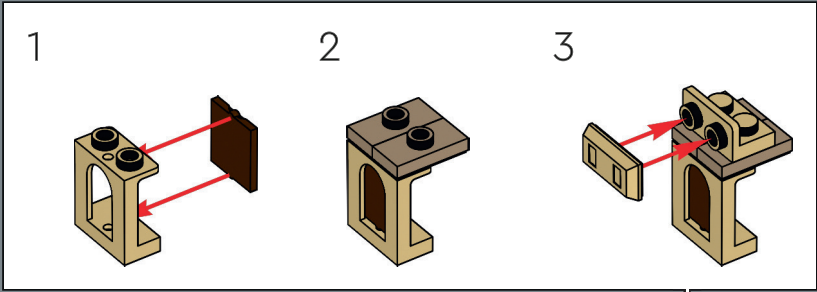

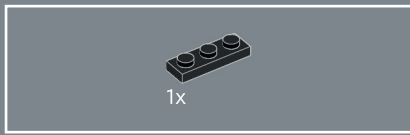

9

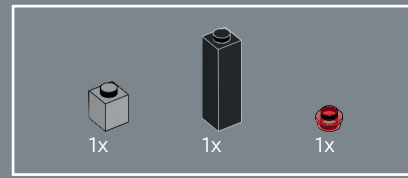
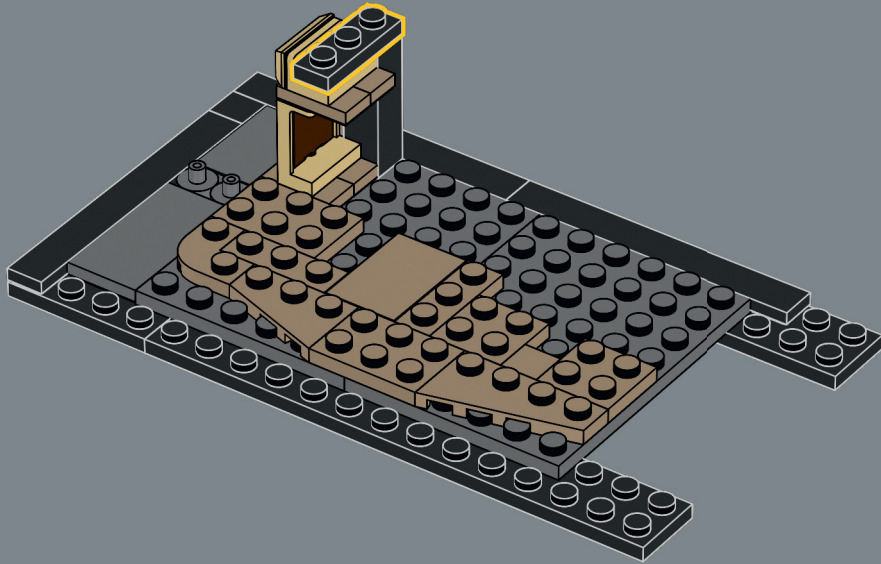

10

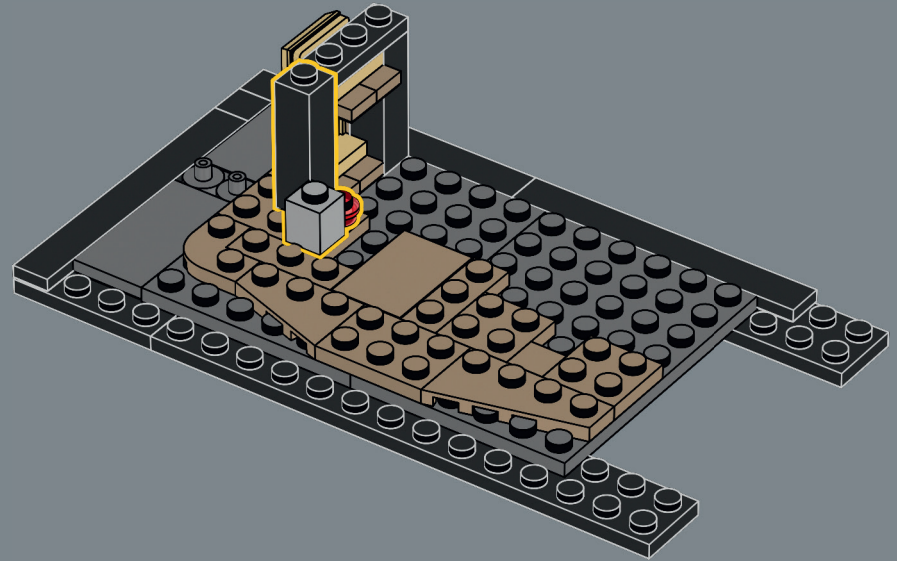



11

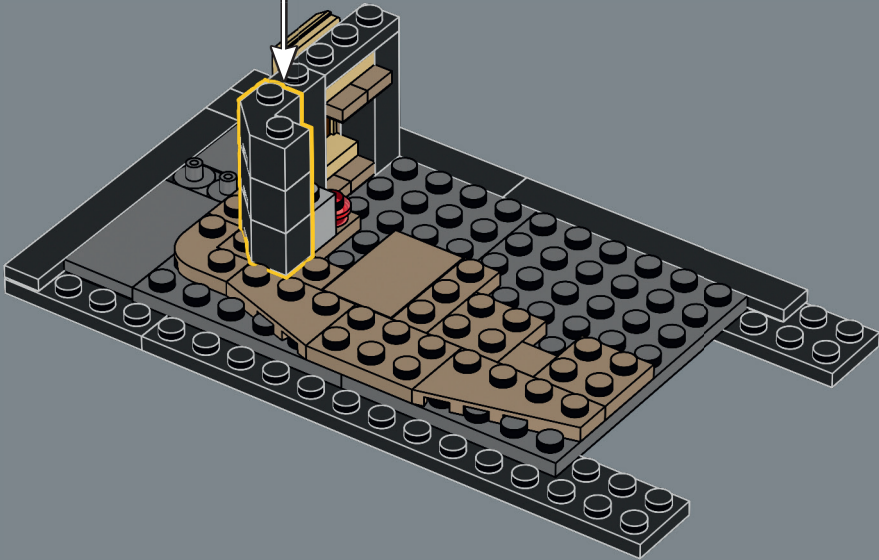
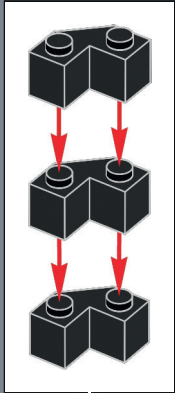

12

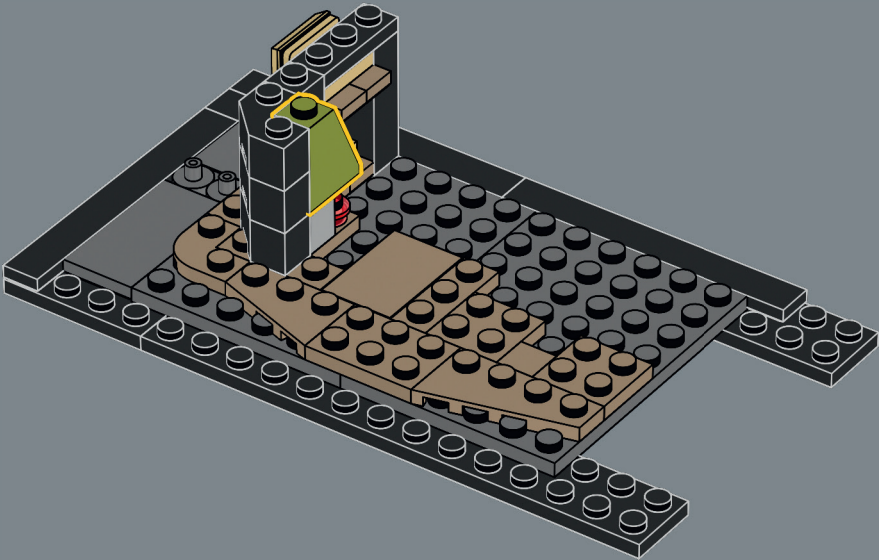



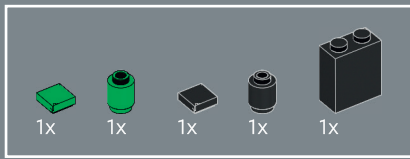

13

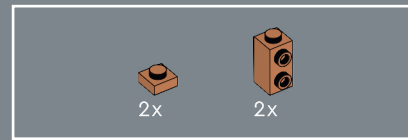
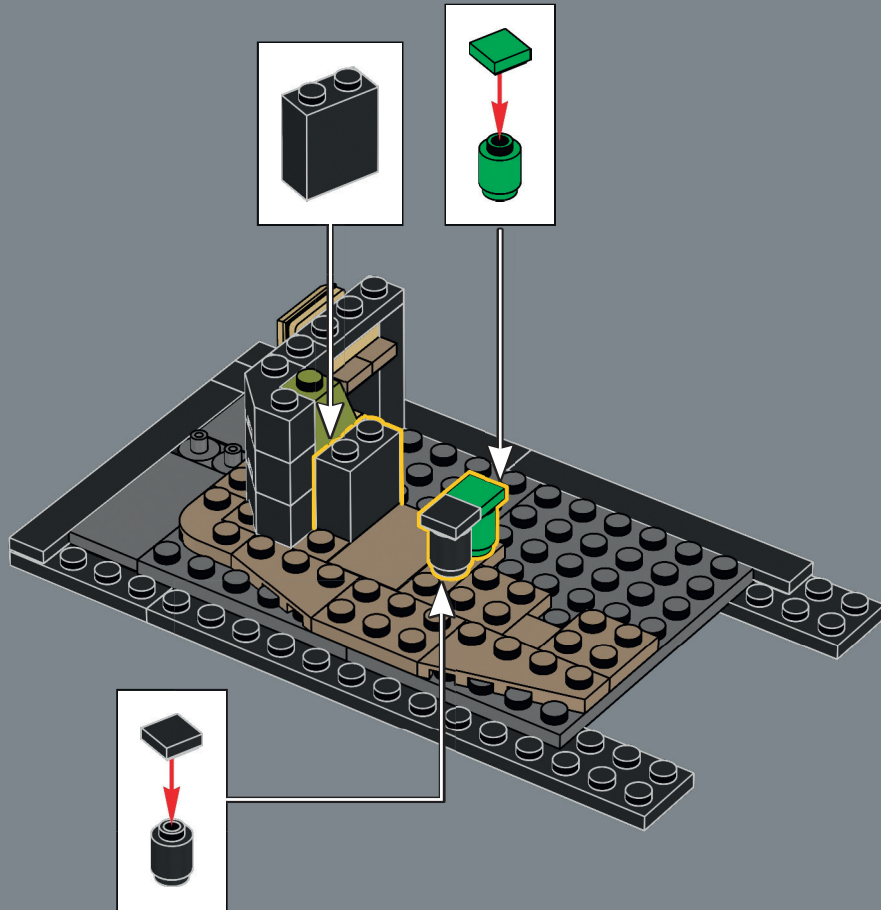

14

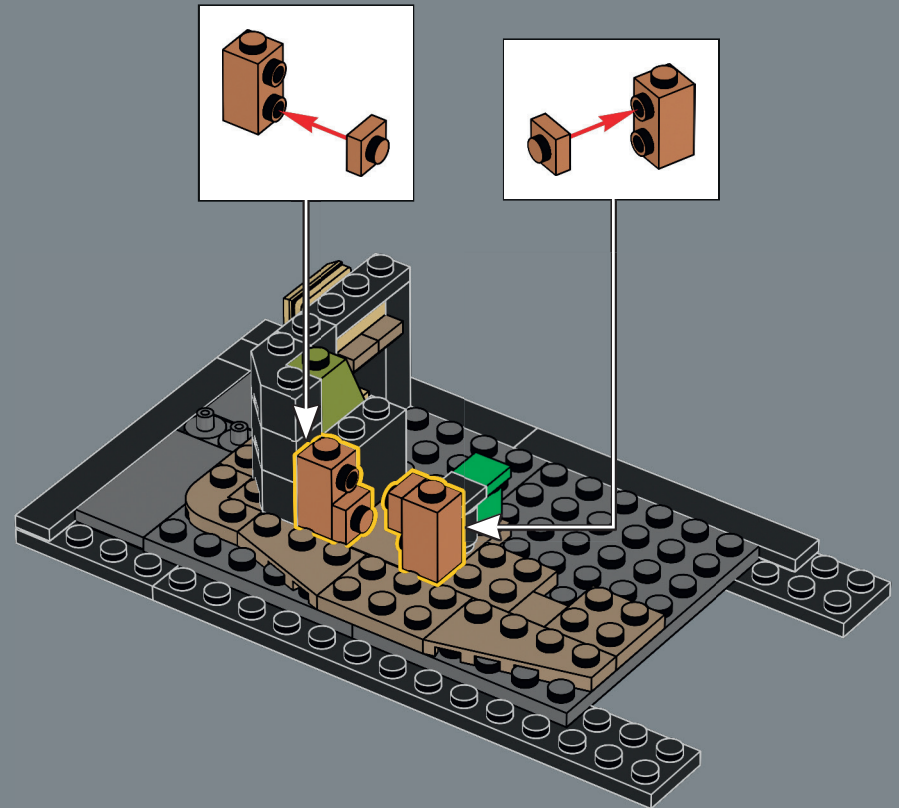

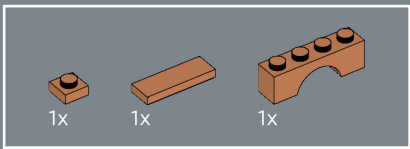

15

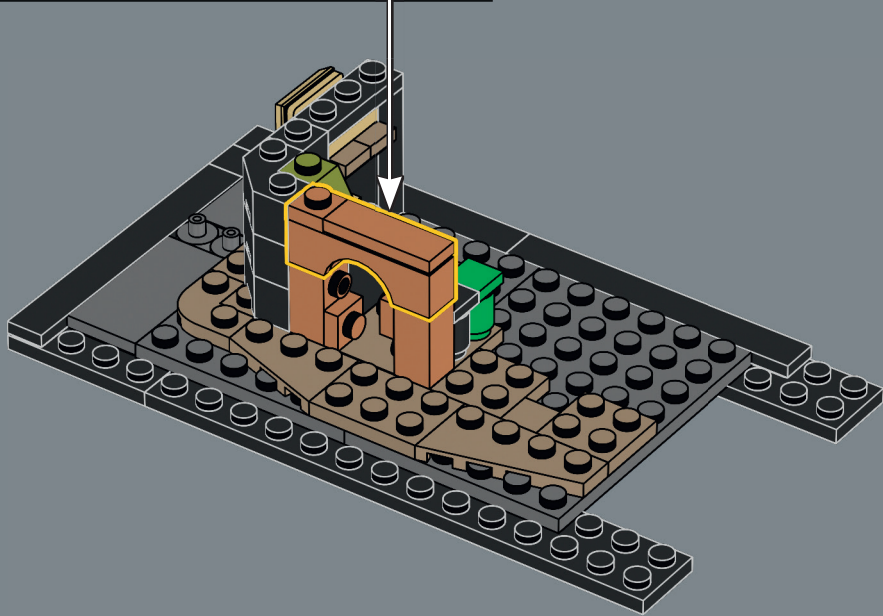
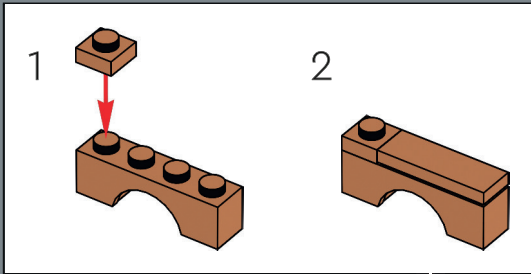

16

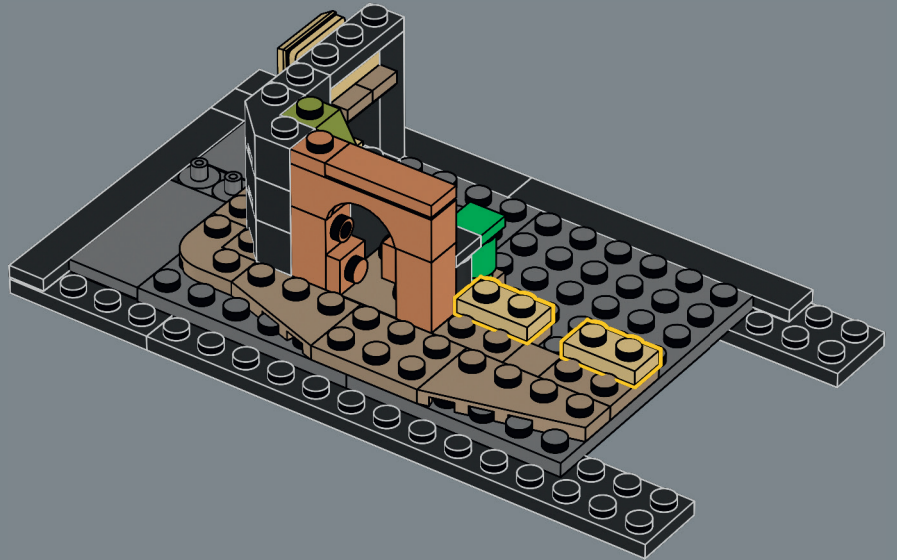

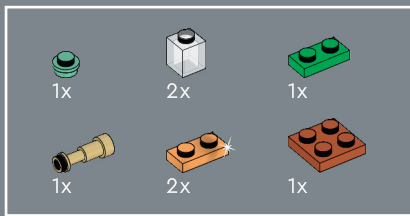

17

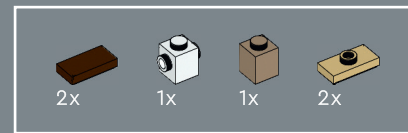
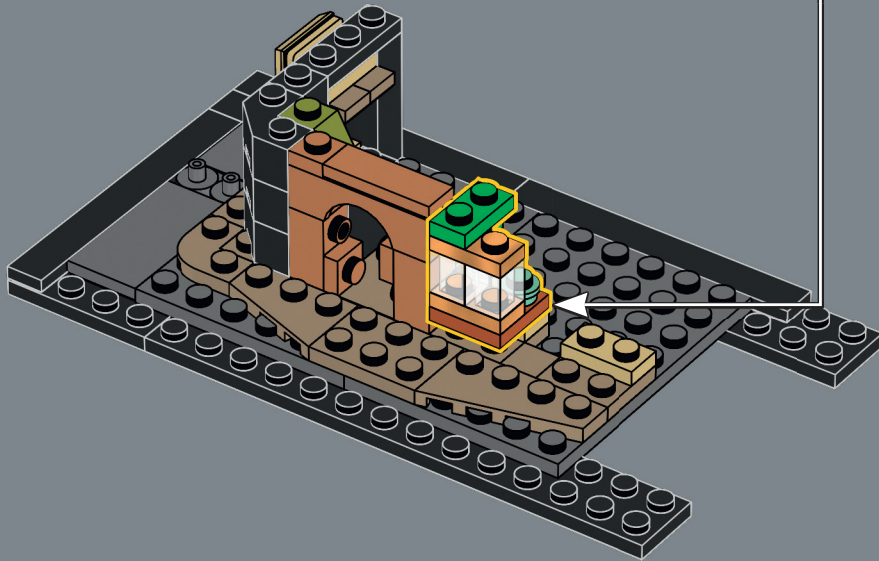
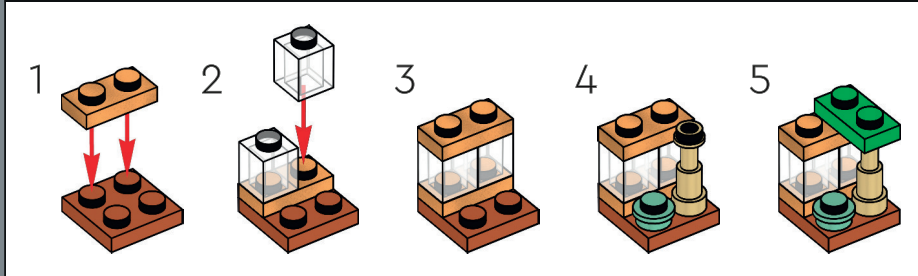

18

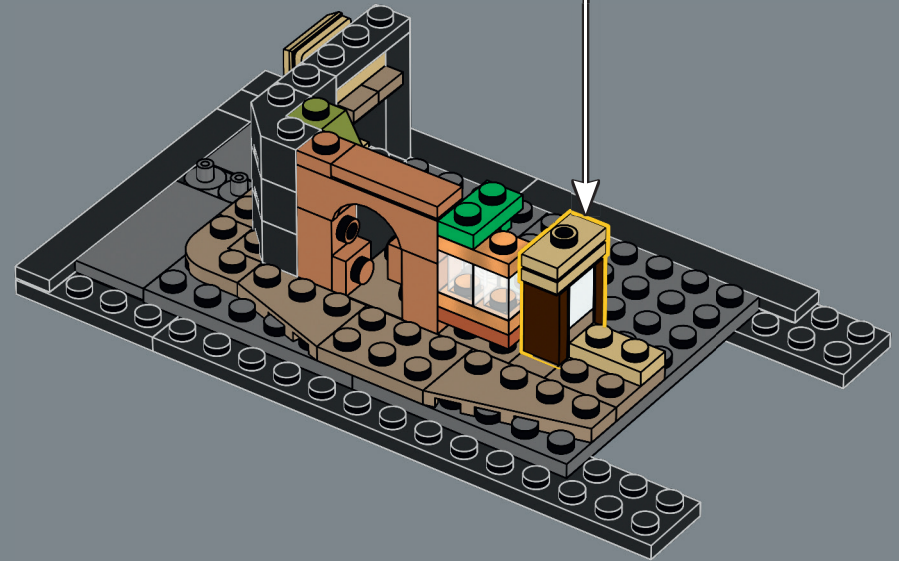
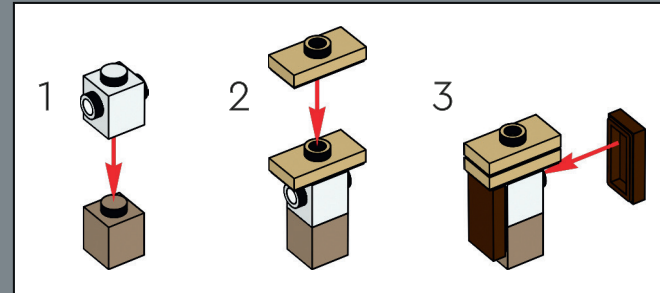

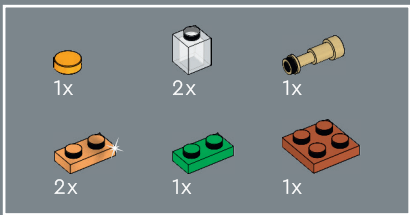

19

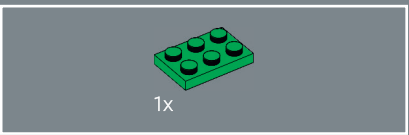
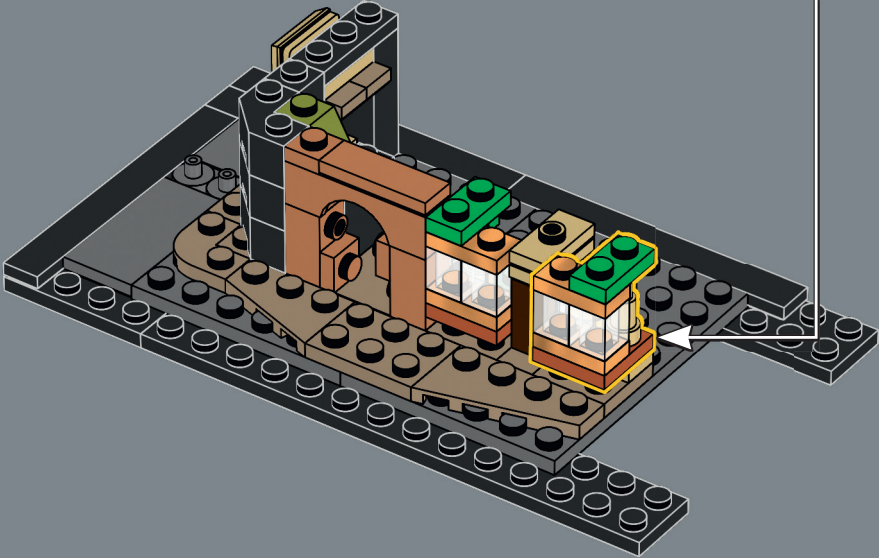
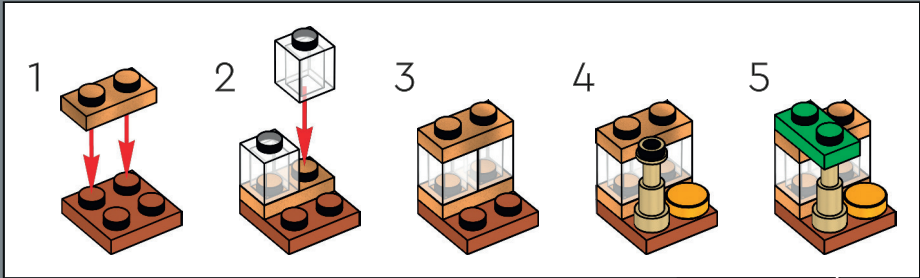

20

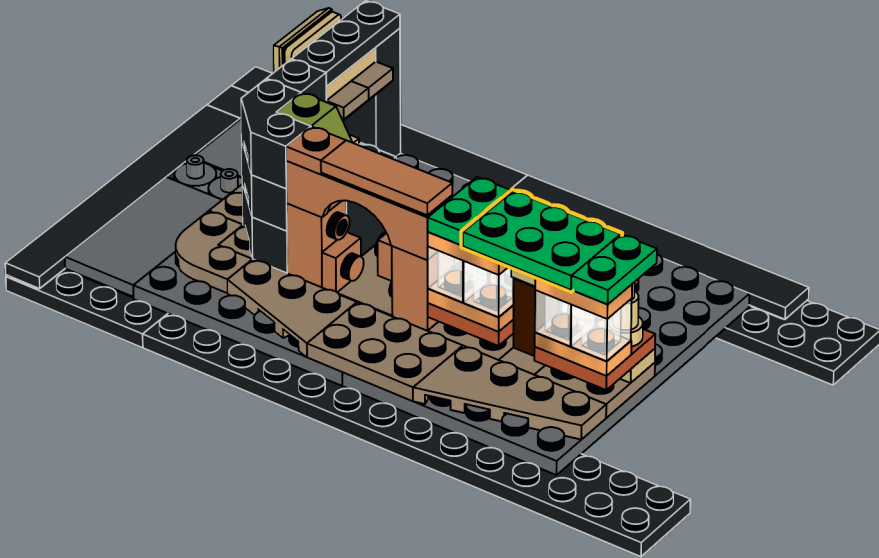



21

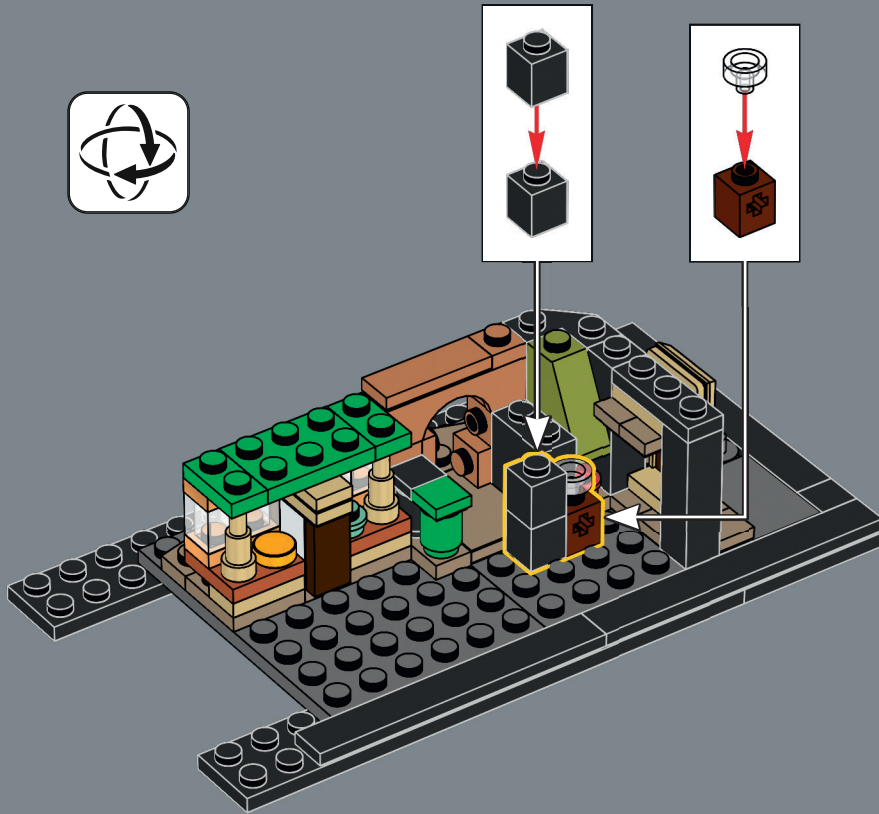

22



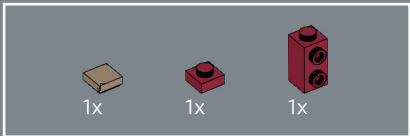

23

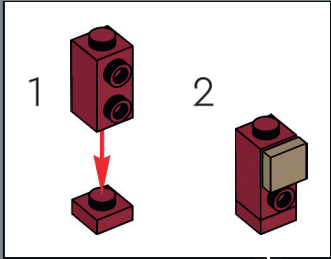

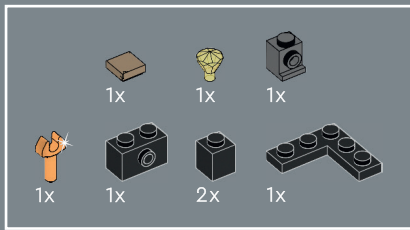

24

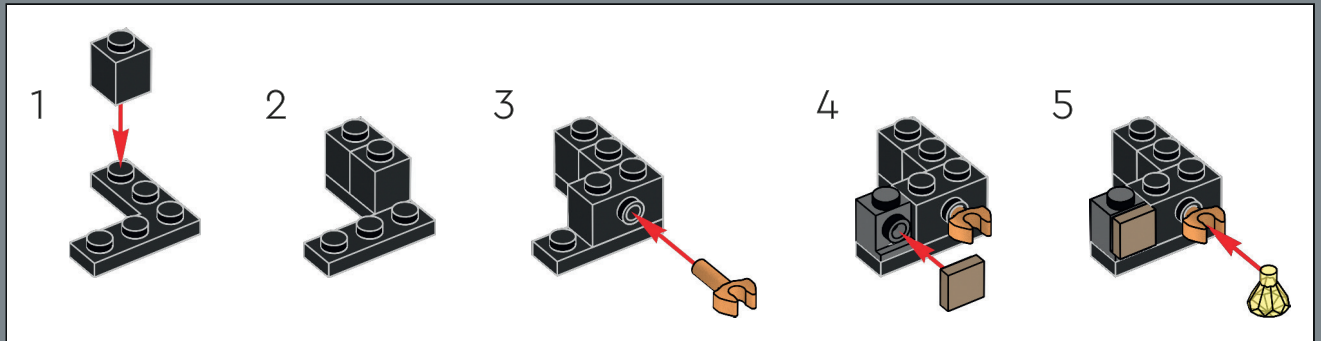

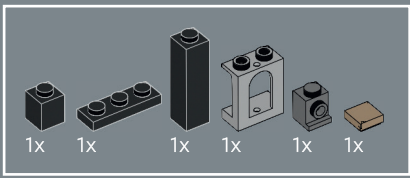

25

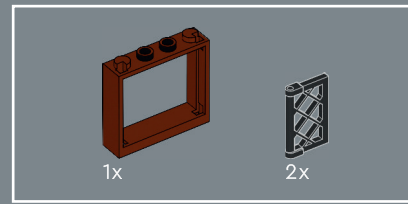
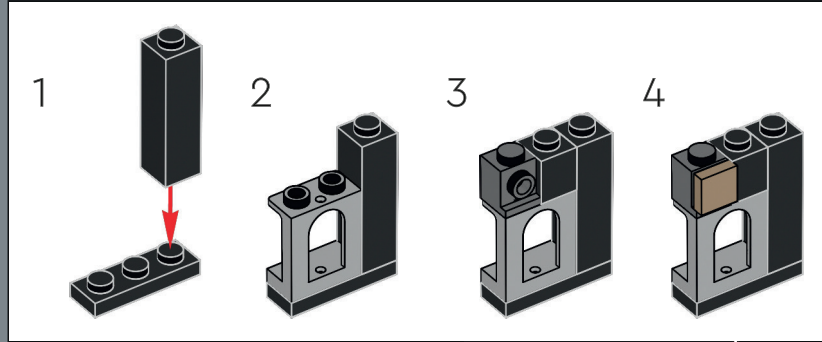

26

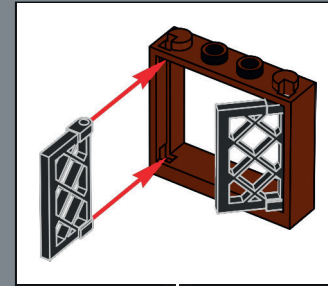





27

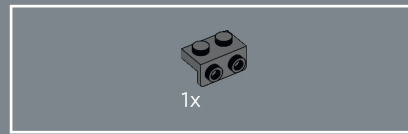

28



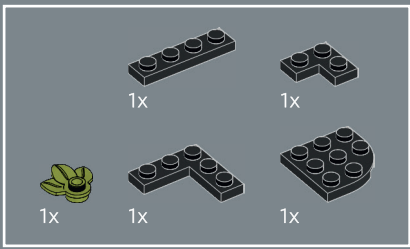

29

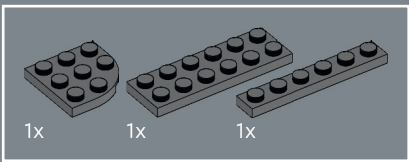

30



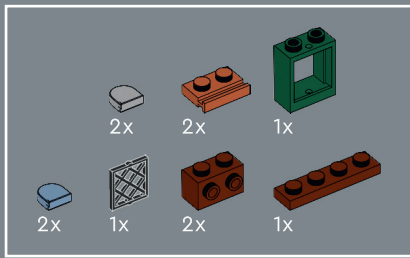

31

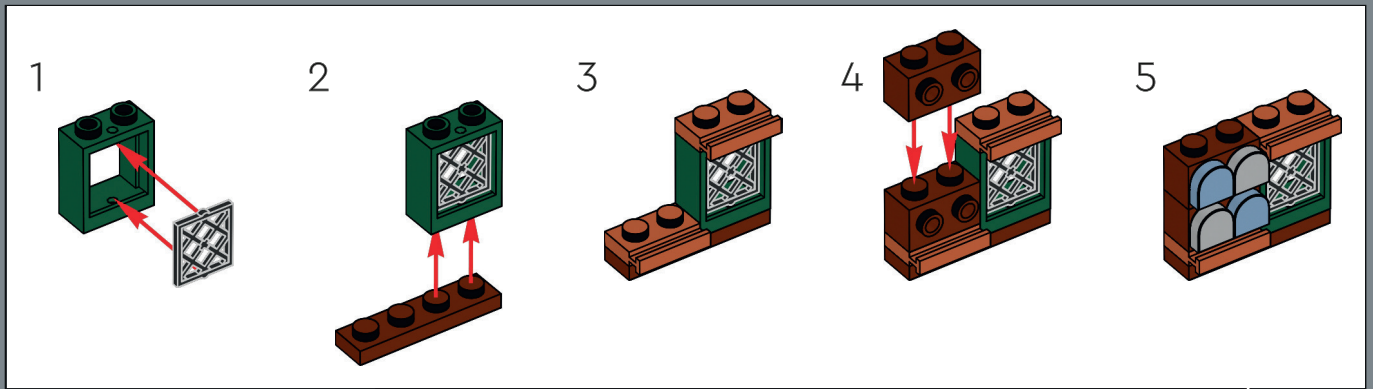



32

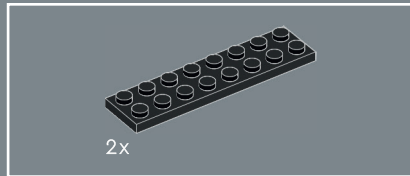

33

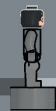

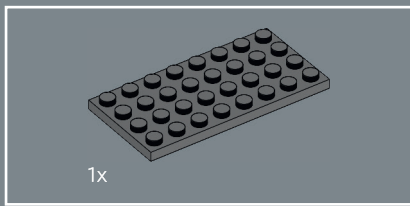

34

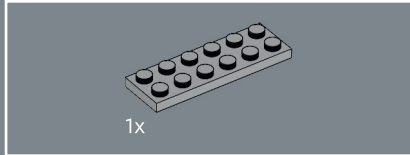

35



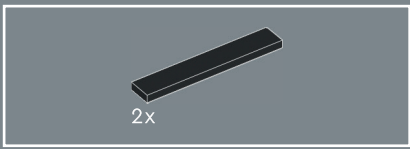

36

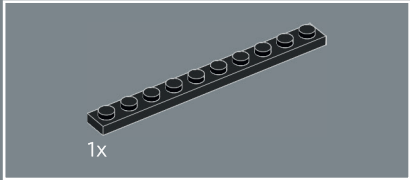

37



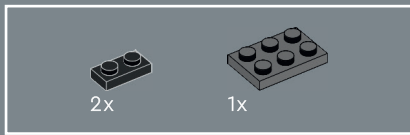

38

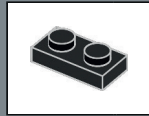
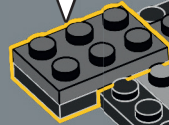
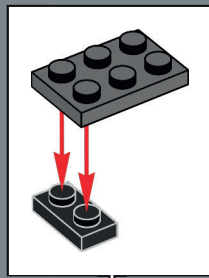

39

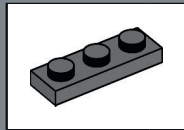
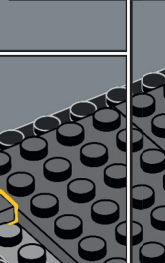
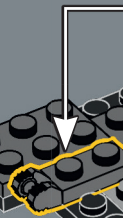
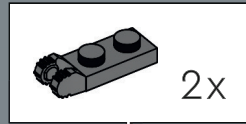

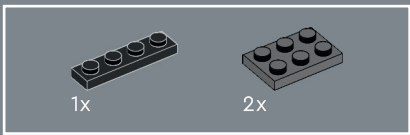

40

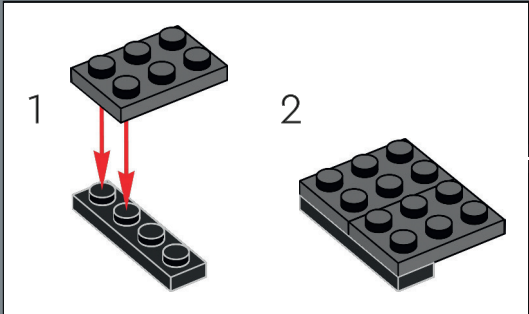



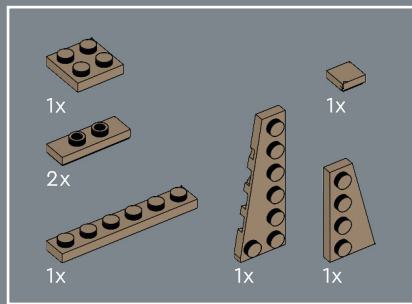

41

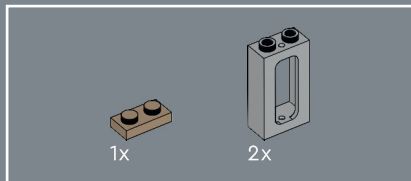

42



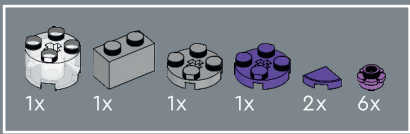

43



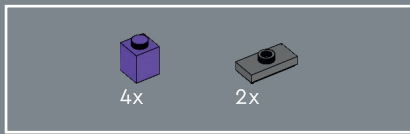

44

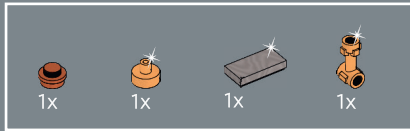
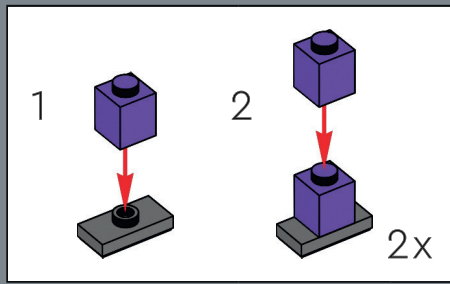

45

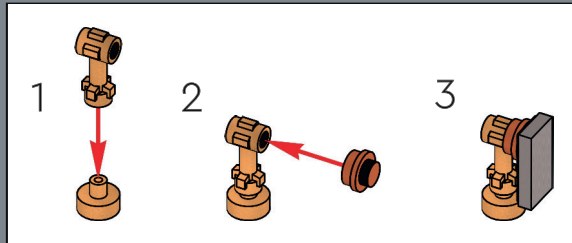



46

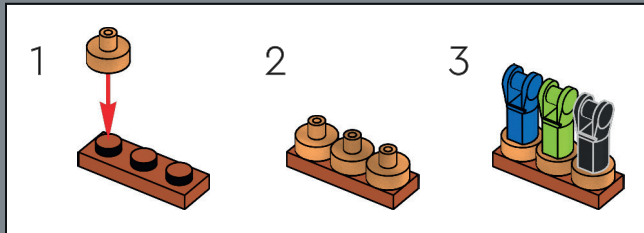

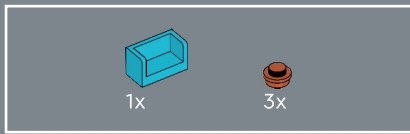

47

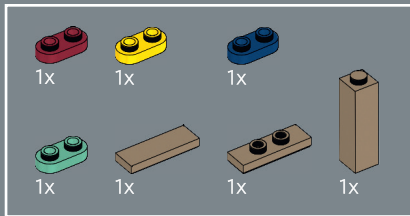
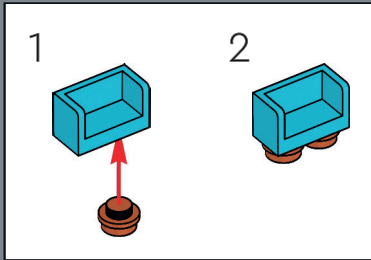

48



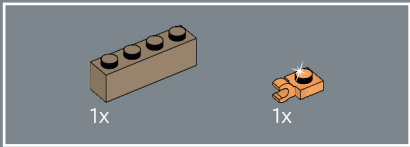
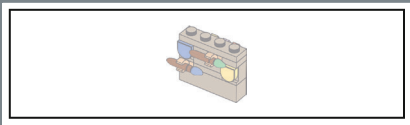

49

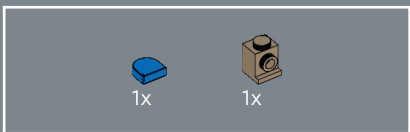
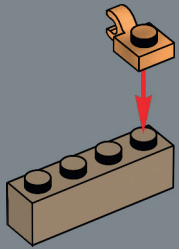

50

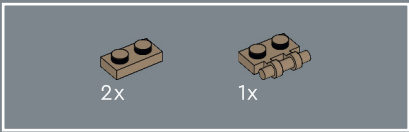
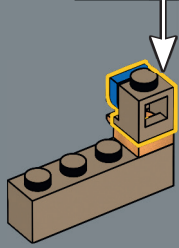
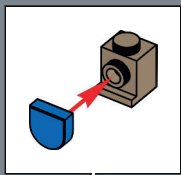

51

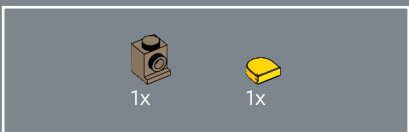
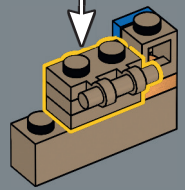
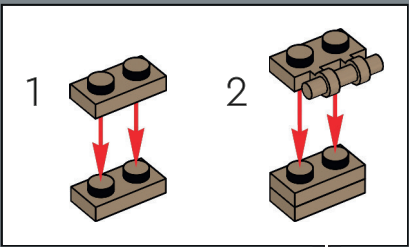

52

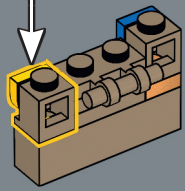
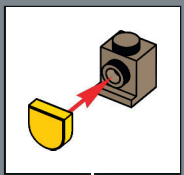



53

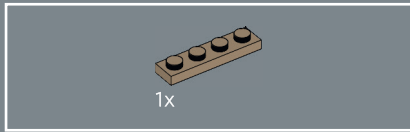
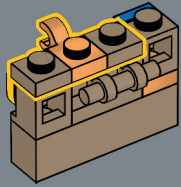

54

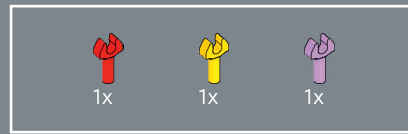
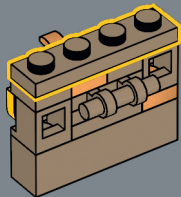

55

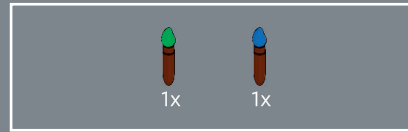
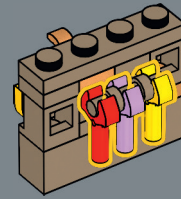

56

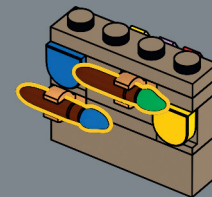







58

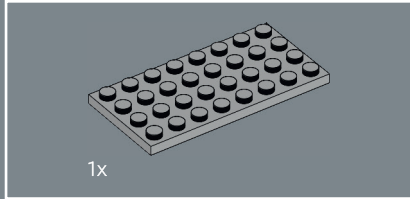

59





60

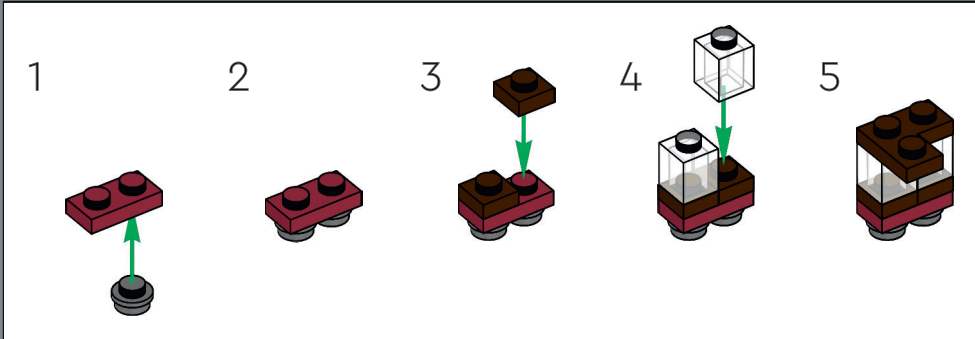



61

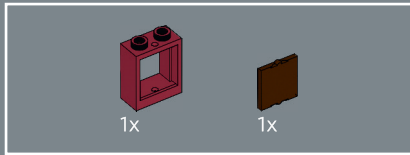

62

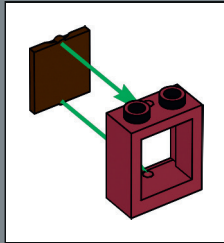



63

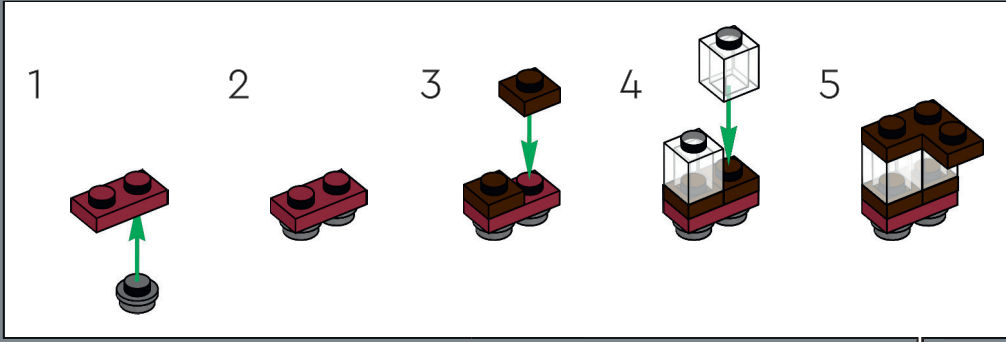



64



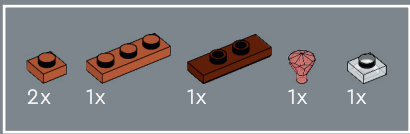

65

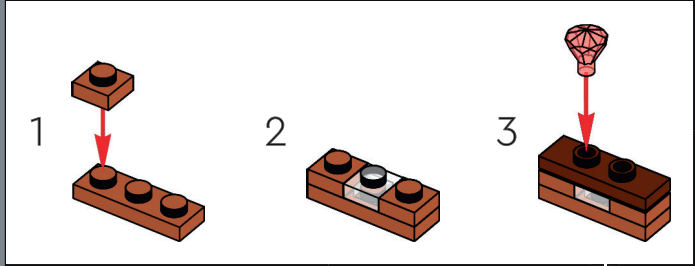

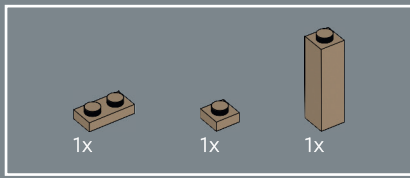

66



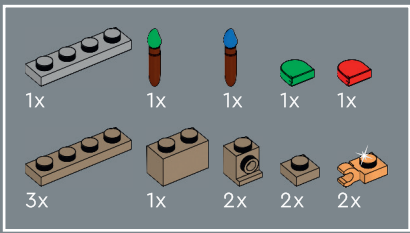

67

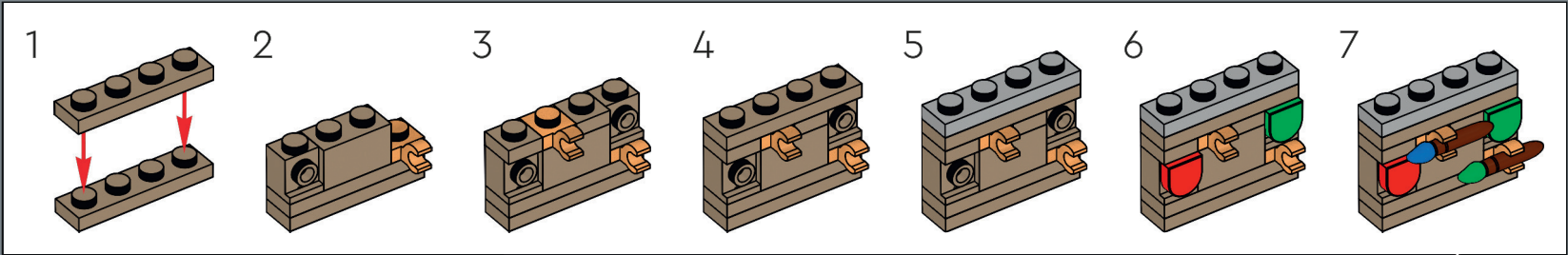



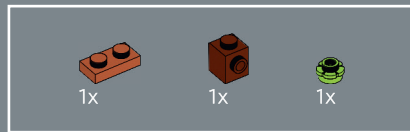

68

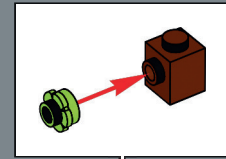

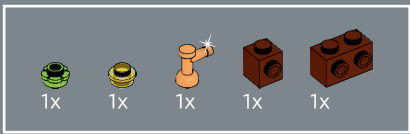

69

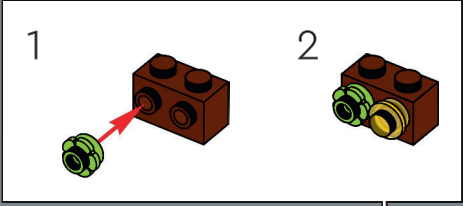
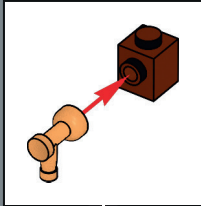

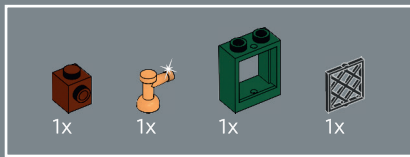

70

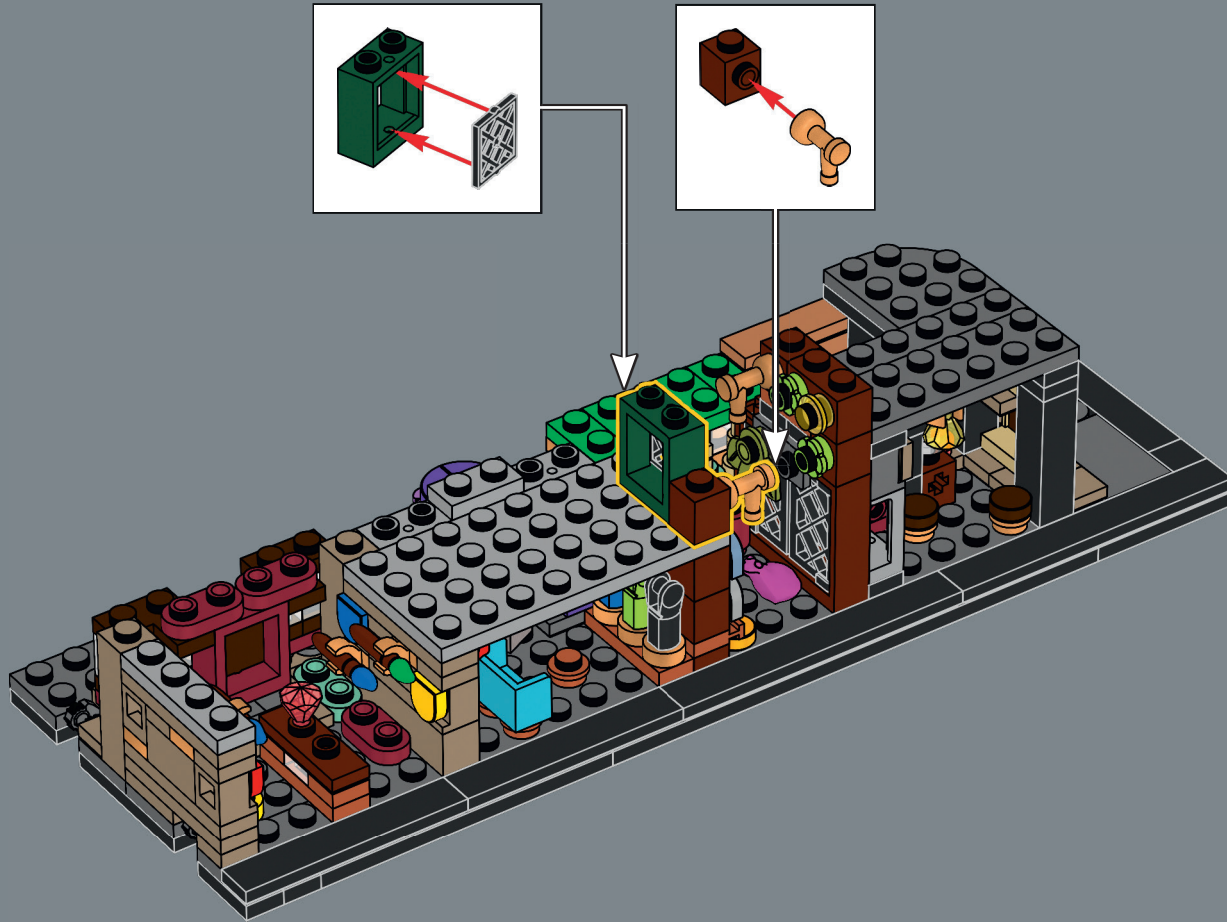



71

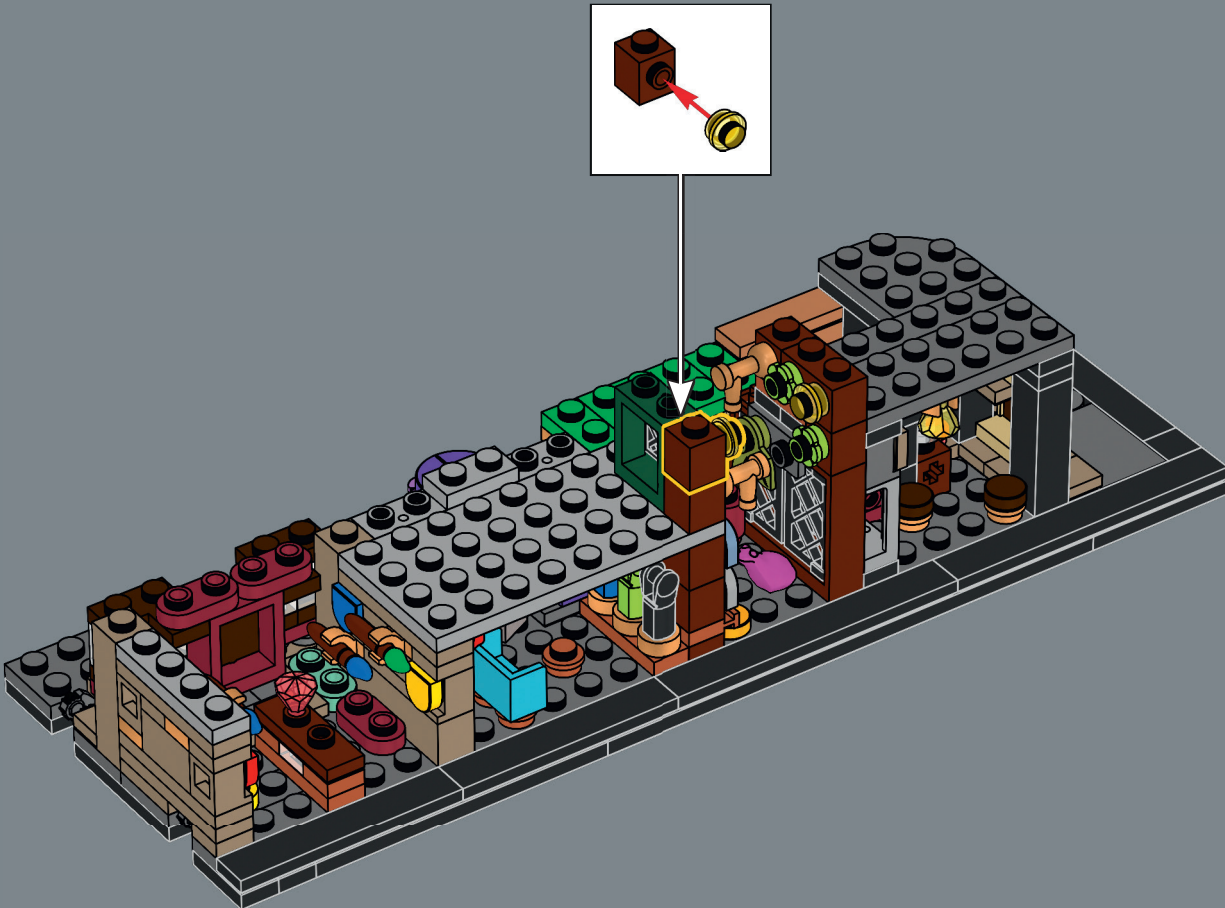

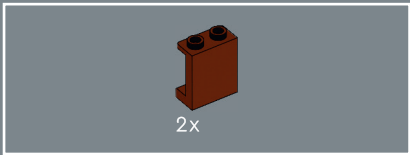

72



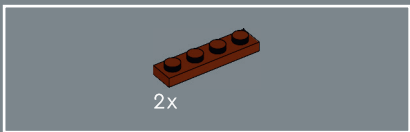

73



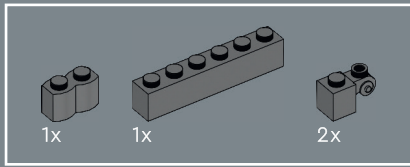

74



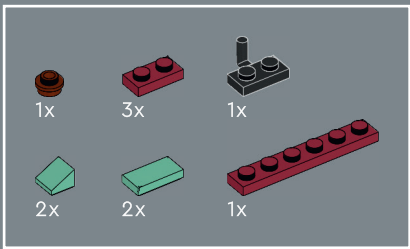

75

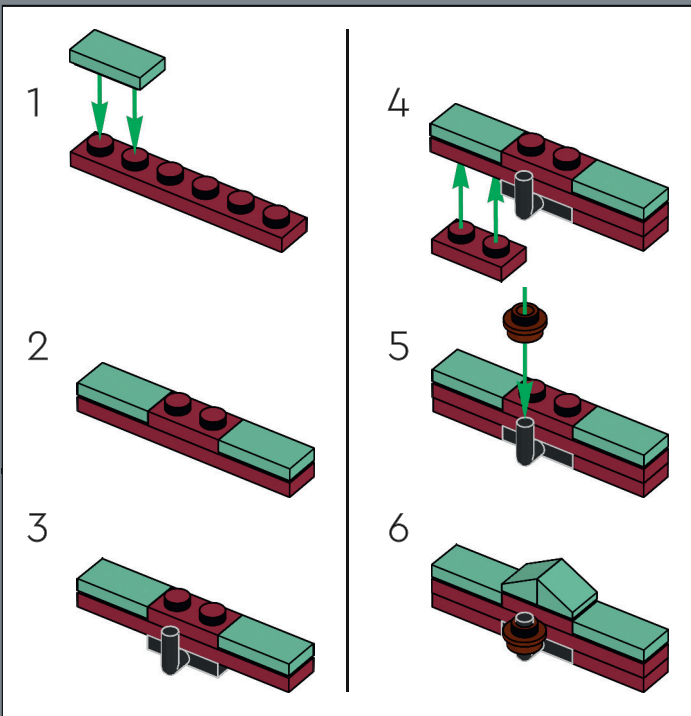



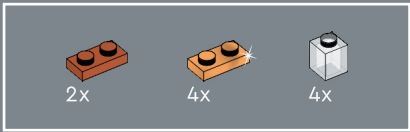

76

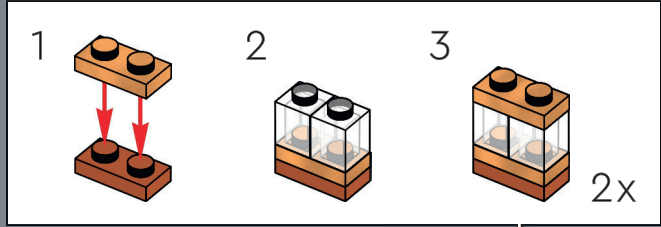

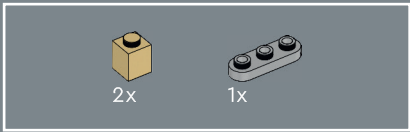

77

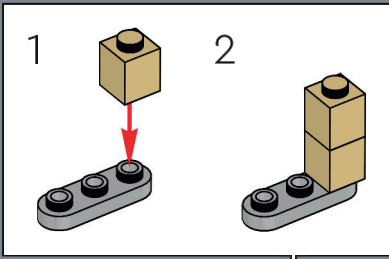



2x

78



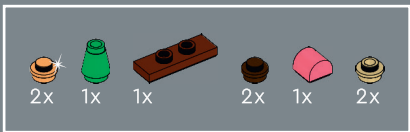

79

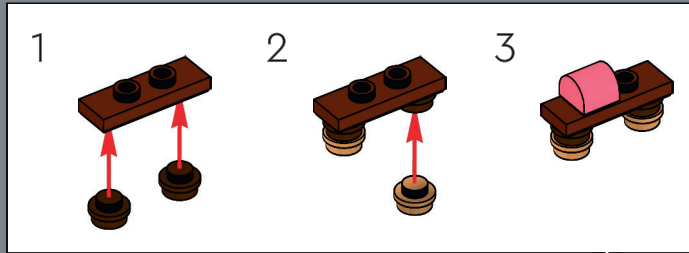

 1x	 2x	 1x
--	--	--

80



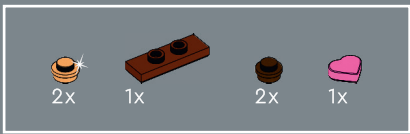

81

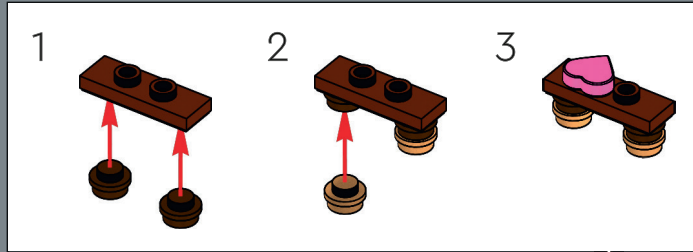



1x



1x

82





83

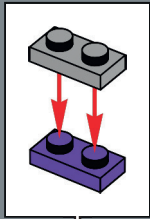



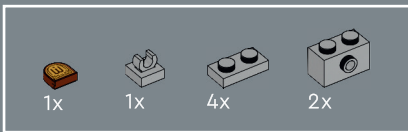

84

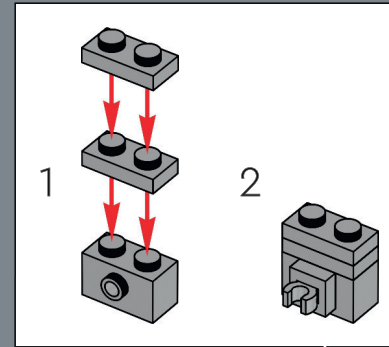
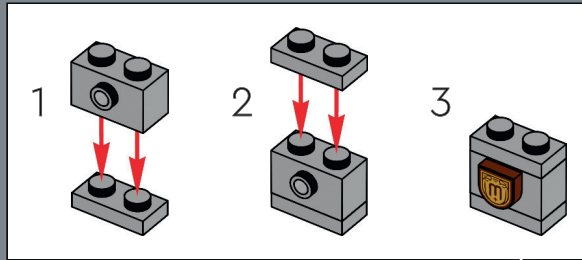

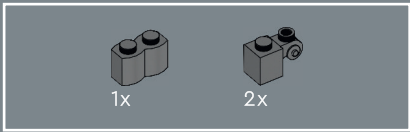

85



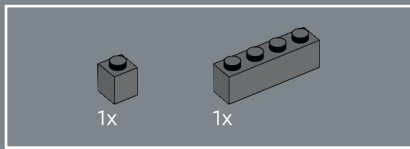

86



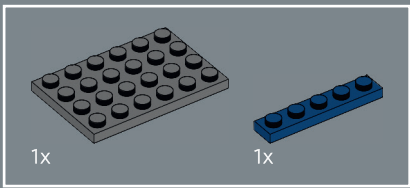

87



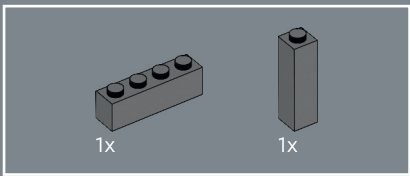

88



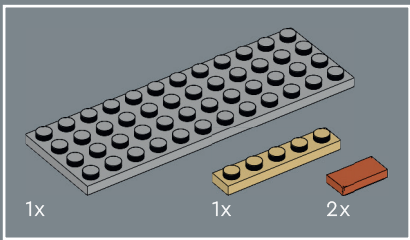

89





90

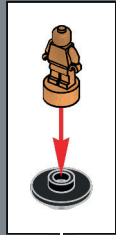
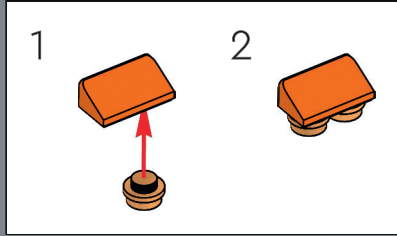

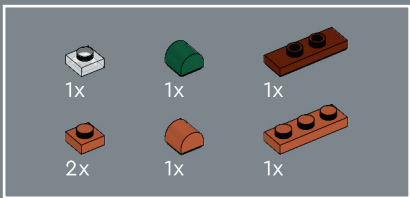

91

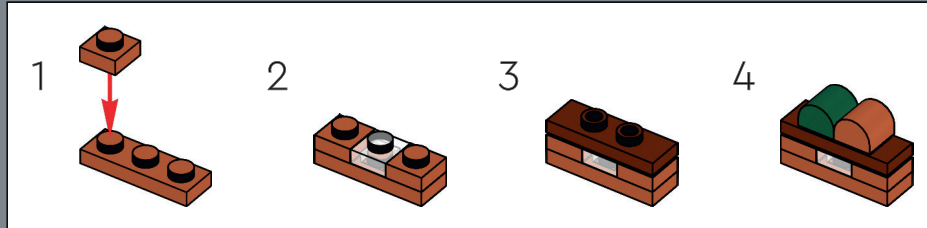



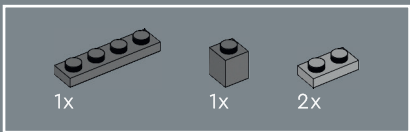

92

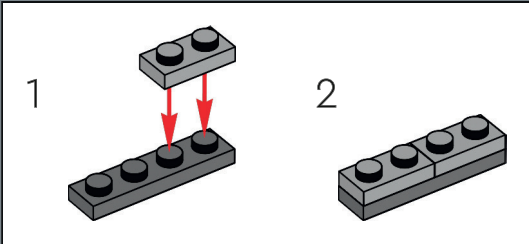

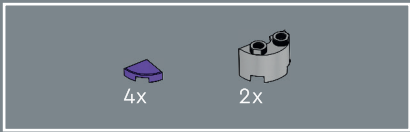

93

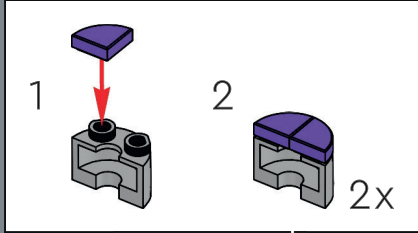



94

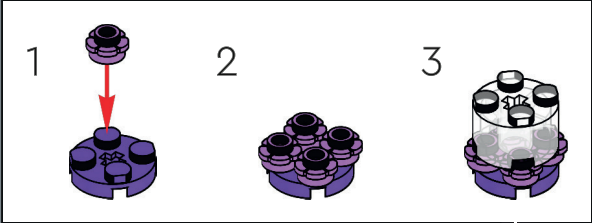



1x

95



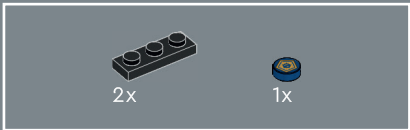

96

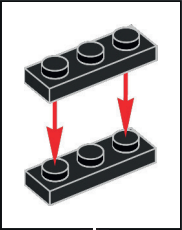



2x



2x



1x

97

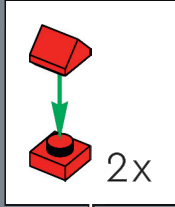

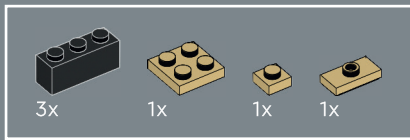

98



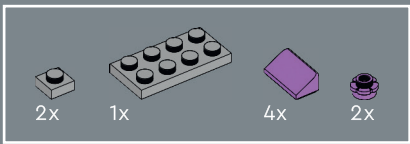

99





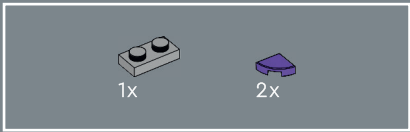

100





101

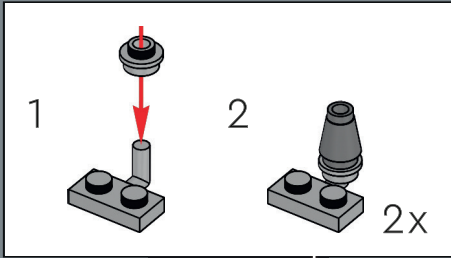



102

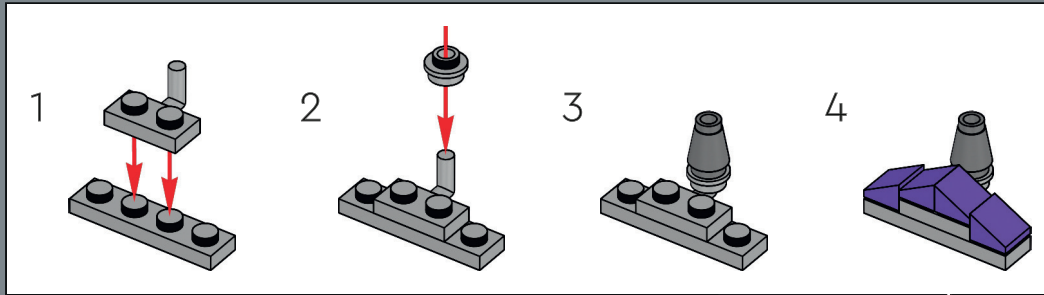



2x

103



**Madame Guipure,  
prêt-à-porter pour  
mages et sorciers**

Célèbre pour ses vêtements de qualité visant à répondre aux besoins des sorcières et des sorciers de tous âges : des uniformes scolaires de Poudlard aux robes de soirée, en passant par les capes de voyage.

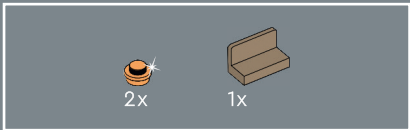

104

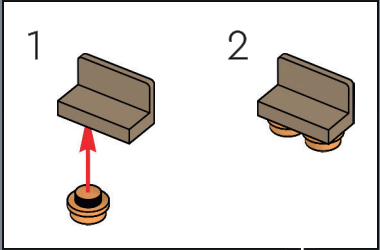

- 1x
- 2x
- 1x
- 1x

105

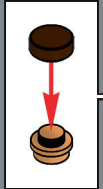
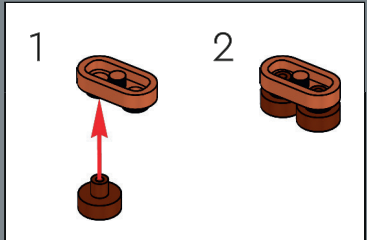

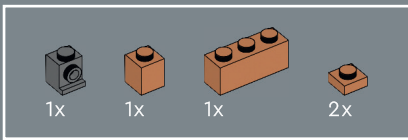

106

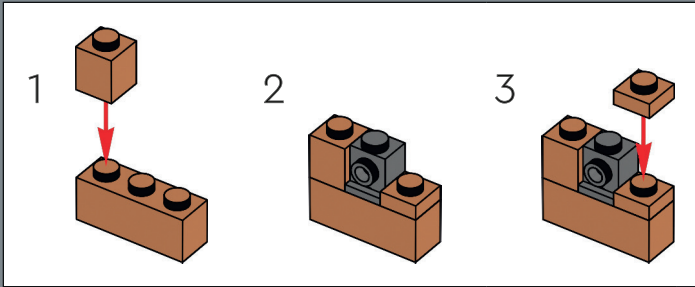

- 1x 
- 1x 
- 1x 
- 1x 

107





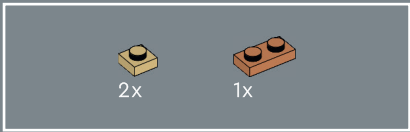

108

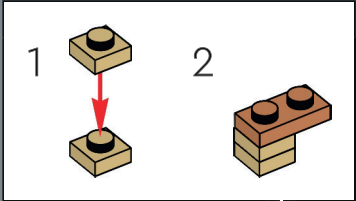



2x

109



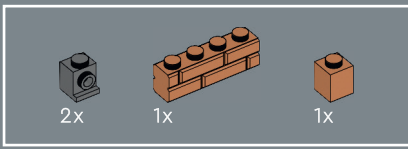

110

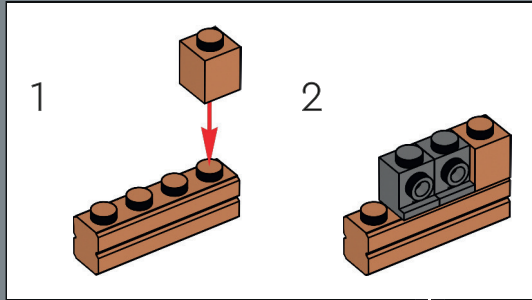

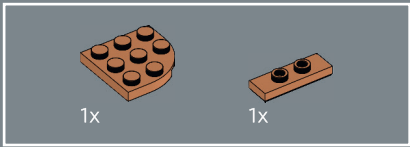

111



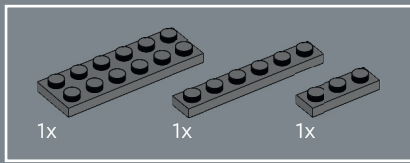

112



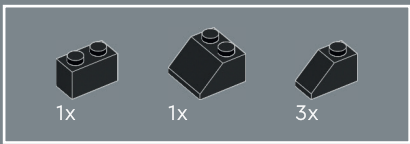

113



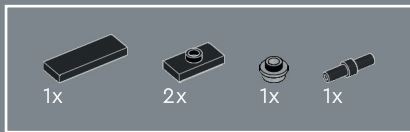

114

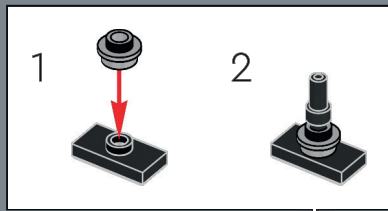

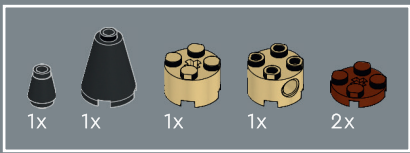

115

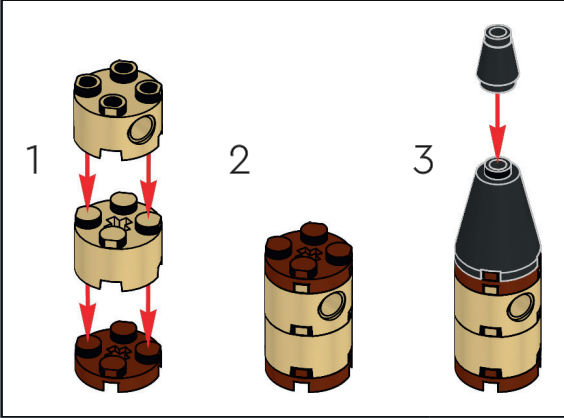





2x



2x

116

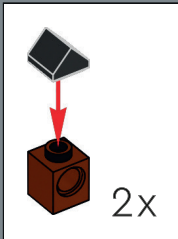

## La Ménagerie magique

La Ménagerie magique est spécialisée dans les créatures magiques et tous leurs soins essentiels. C'est là qu'Hermione a adopté Pattenrond, un chat mi-Fléreur affectueux et indépendant qui adore attraper les rats !



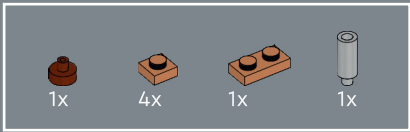

117



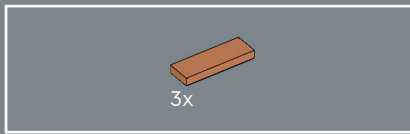

118



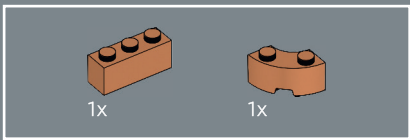

119



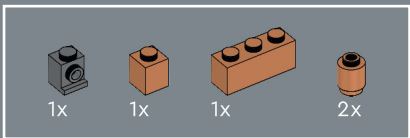

120



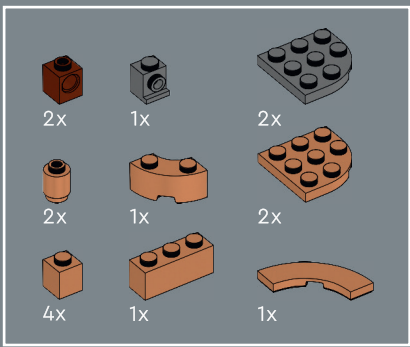

121

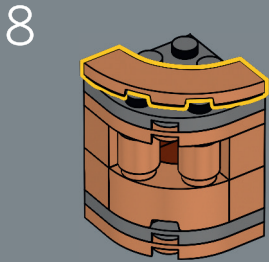
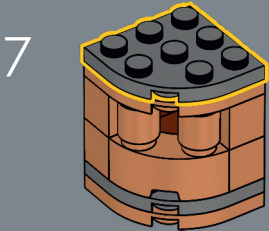
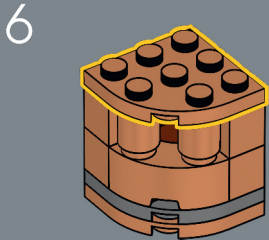
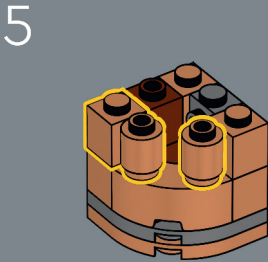
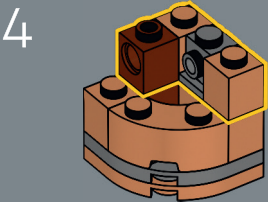
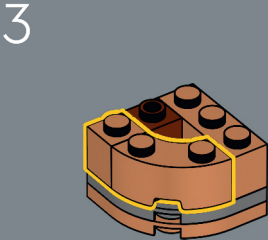
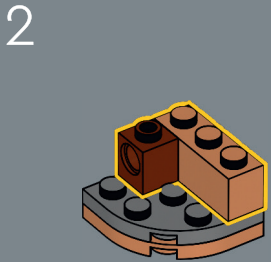
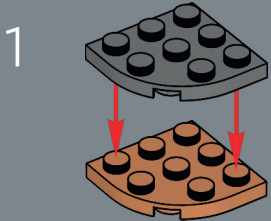



### Le Chaudron Baveur

Le Chaudron Baveur est le plus ancien pub de Londres et il est célèbre pour ses plats copieux. Malgré son extérieur modeste (et sa clientèle mystérieuse), il sert de passerelle magique entre le monde moldu et le monde des sorciers.

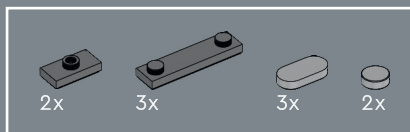

122





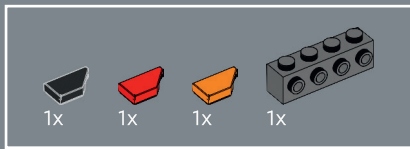

123

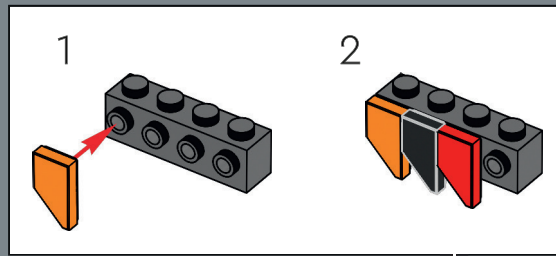

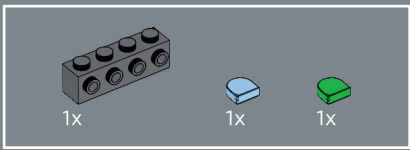

124

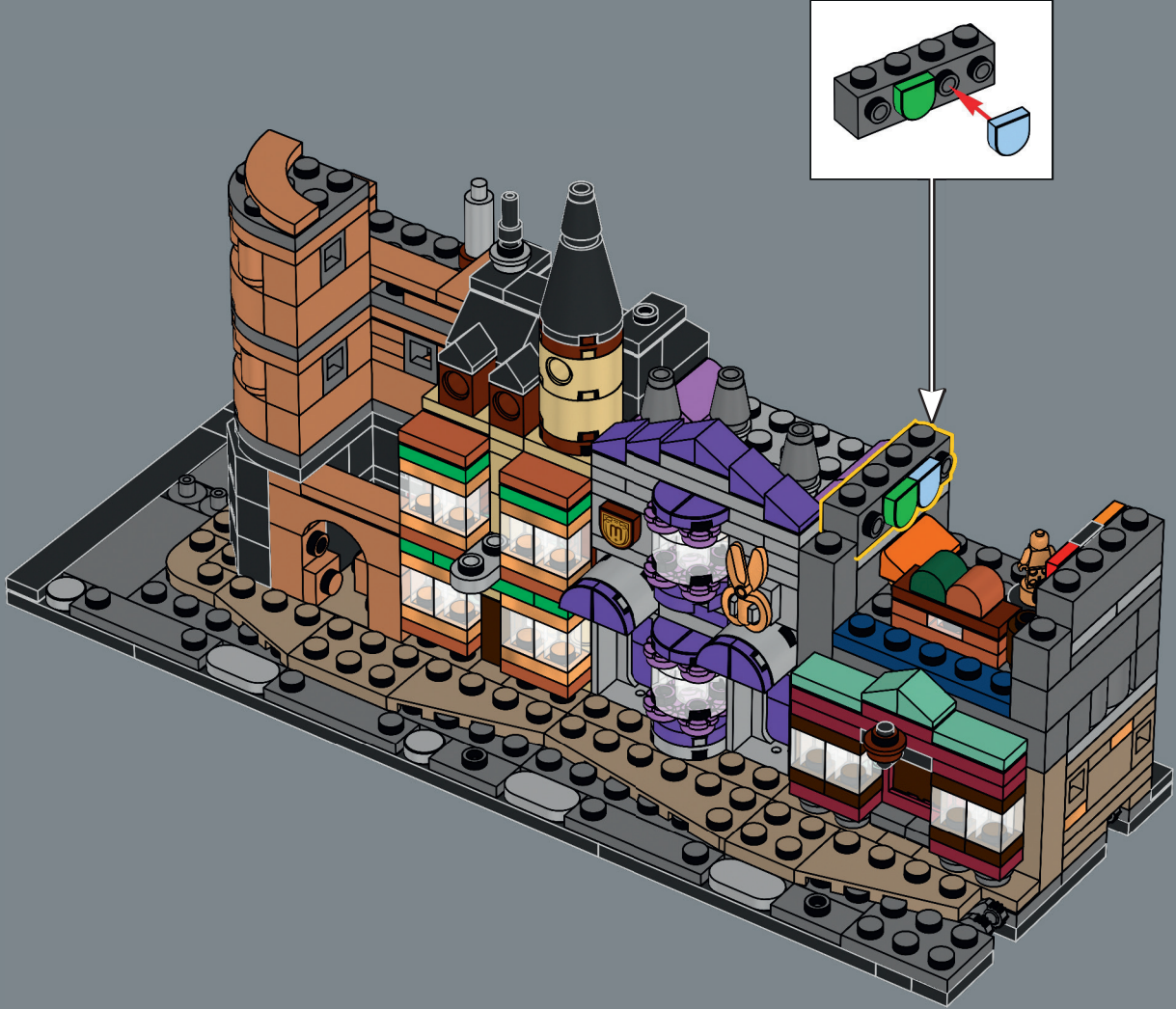

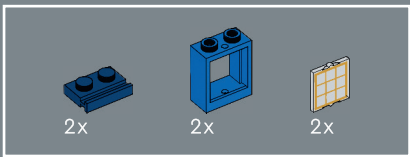

125

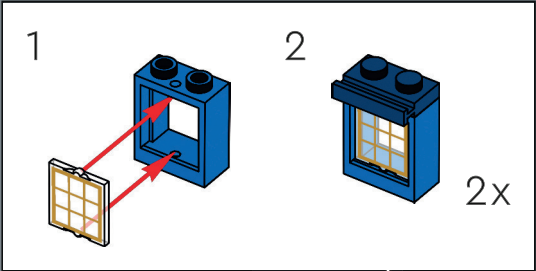

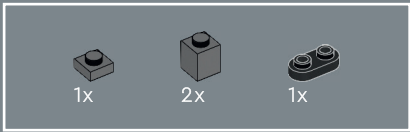

126

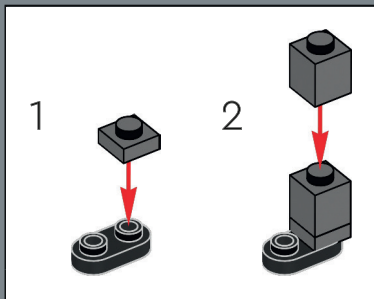

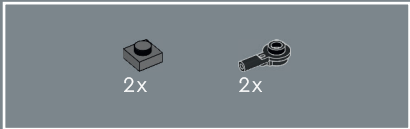

127



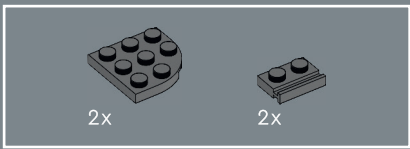

128



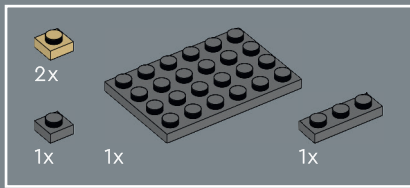

129



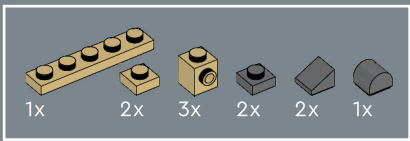

130

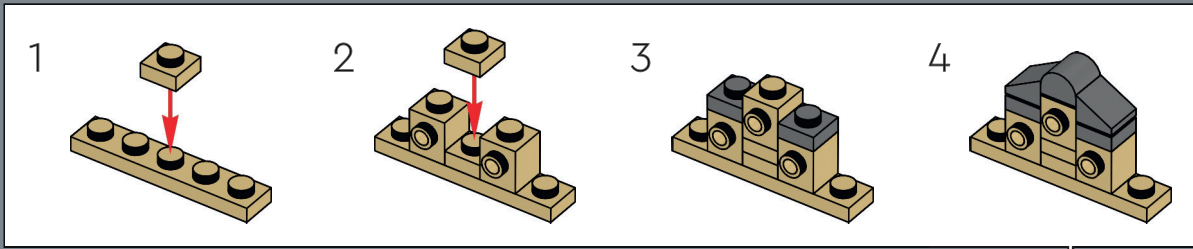



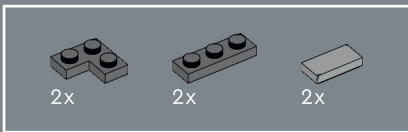

131





2x



2x

132



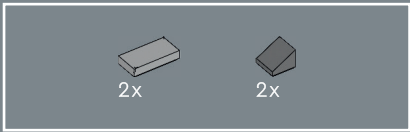

133





3x

134



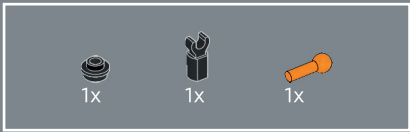

135

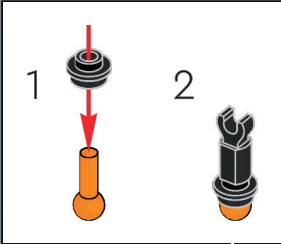

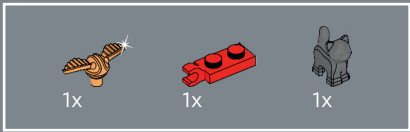

136



### Le Magasin d'accessoires de Quidditch

La plaque tournante incontestée de toutes les dernières tendances en matière d'équipements de Quidditch™. Les élèves de Poudlard y viennent régulièrement, car ils rêvent de voler au-dessus du terrain de Quidditch de l'école à bord des balais de course les plus rapides du monde des sorciers.

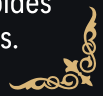

2x

137



-  2x
-  2x
-  2x
-  2x

138

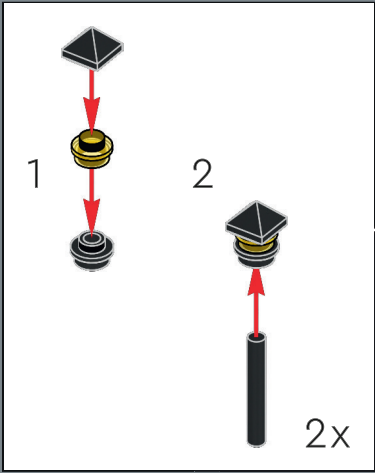



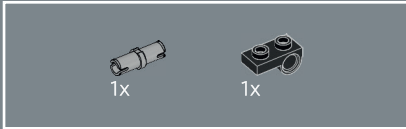
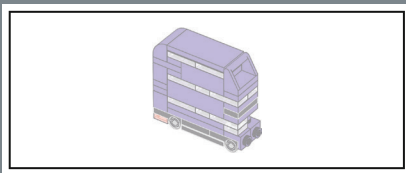

139

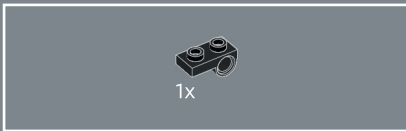
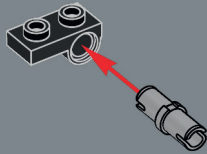

140

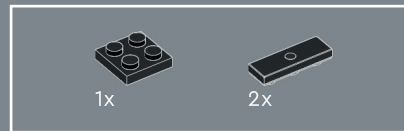
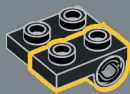

141

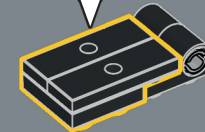
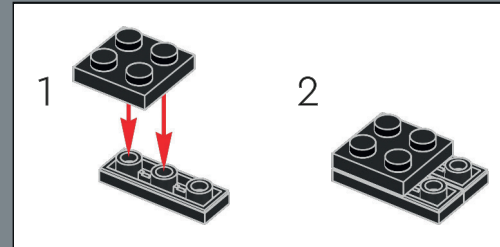

142

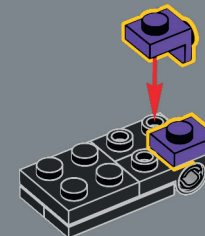

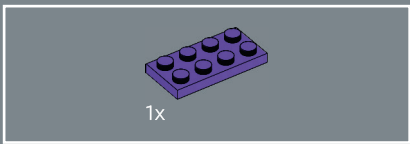

143

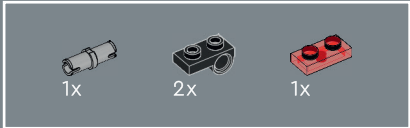
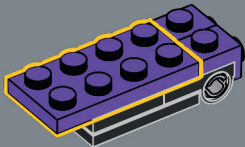

144

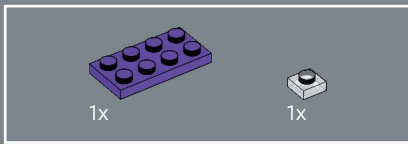
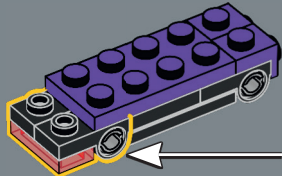
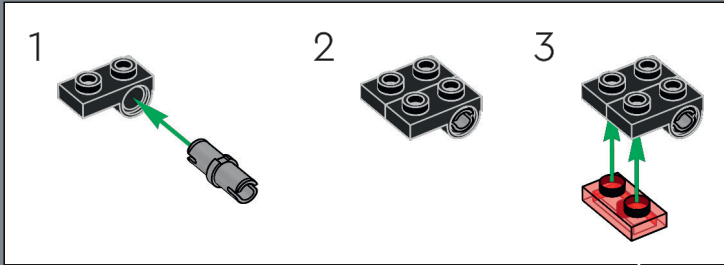

145

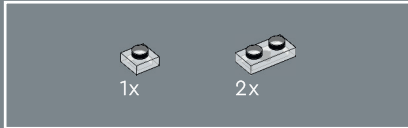
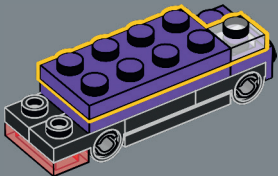

146

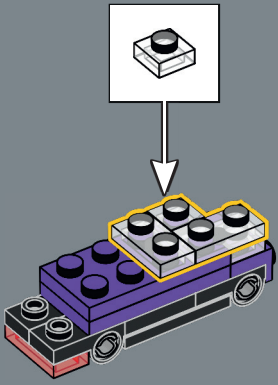

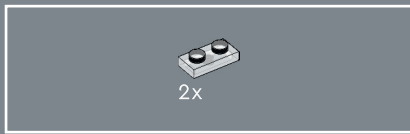

147

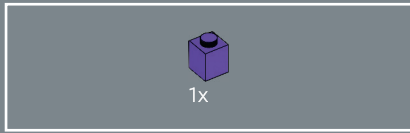
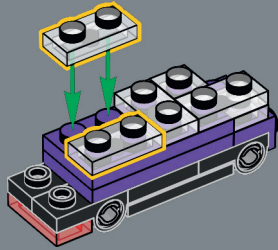

148

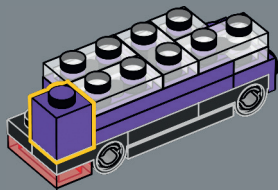

149

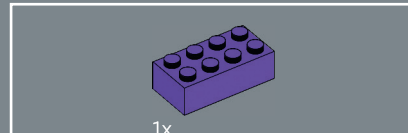
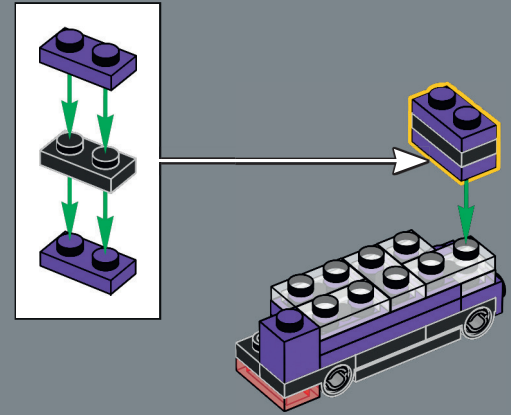

150

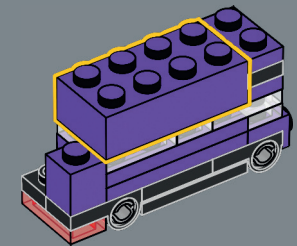



3x

151

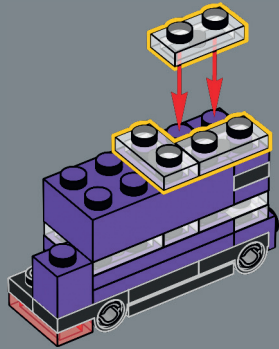

2x

152

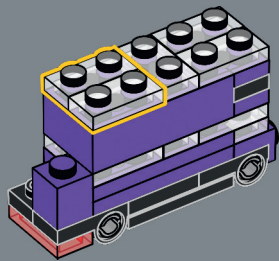

1x



1x



1x



1x

153

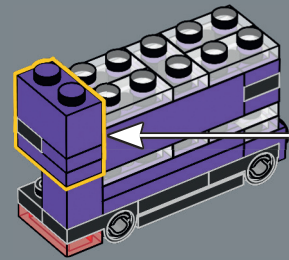
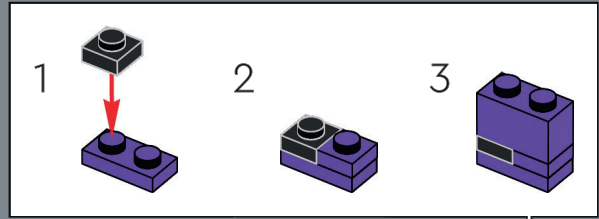

1x

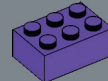

1x

154

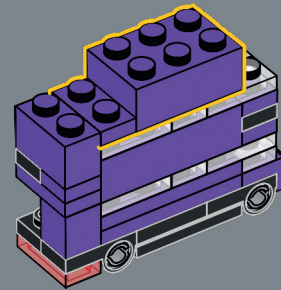

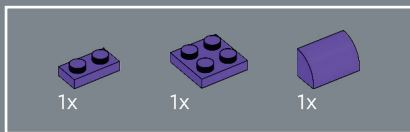

155

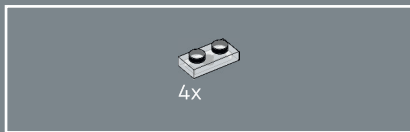
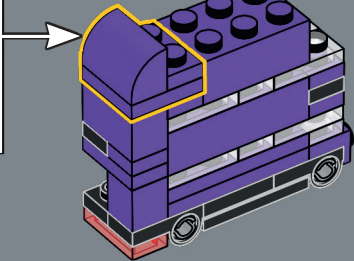
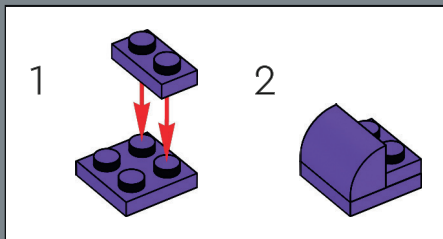

156

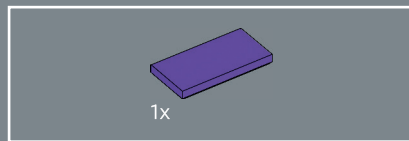
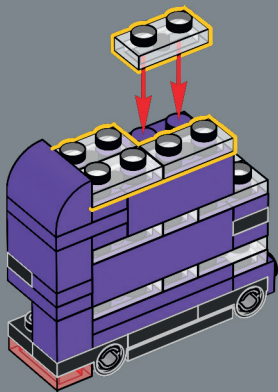

157

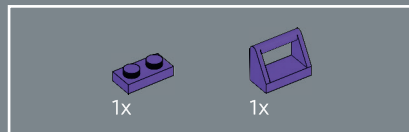
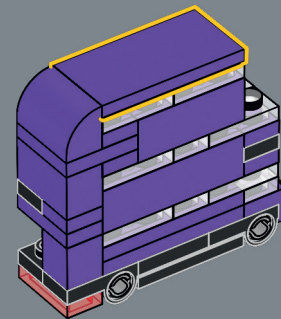

158

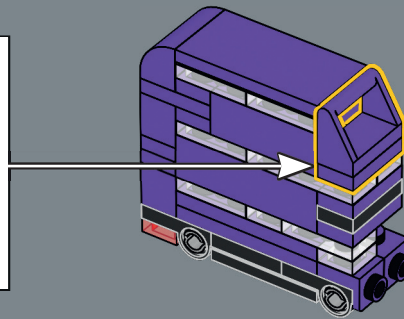
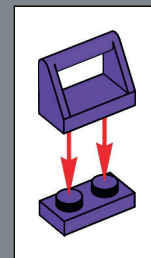

159







LEGO and the LEGO logo are trademarks of the LEGO Group. ©2025 The LEGO Group.

All HARRY POTTER characters and elements © & ™ Warner Bros. Entertainment Inc.  
Publishing Rights © JKR. (s25)