



21062





LEGO.com/sustainable-packaging



FR
DONNEZ
OU
RECYCLEZ



OU



OU



ASSOCIATION MAGASIN DÉCHÈTERIE

Adresses sur quefairedemesdechets.fr



BUILDER



Apple and the Apple logo are trademarks of Apple Inc., registered in the U.S. and other countries and regions. App Store is a service mark of Apple Inc. Google Play and the Google Play logo are trademarks of Google LLC. Tencent and the Tencent logo are trademarks of Tencent Inc.

LEGO.com/devicecheck



LEGO® Builder



IL ÉTAIT UNE FOIS ROME / LA FONTAINE DE TREVÌ

Achevée en 1762, la fontaine de Trevi, telle qu'on peut l'admirer aujourd'hui, offre généreusement depuis des siècles toute la richesse de son patrimoine historique et architectural romain. Le lieu où la fontaine a été érigée a longtemps joué un rôle important dans la croissance et la prospérité de la ville. Depuis 19 avant notre ère, sa source d'eau naturelle s'écoule via l'aqueduc de l'Acqua Vergine (eau pure), l'un des aqueducs romains les plus anciens.

Spectaculaire œuvre d'art baroque, la fontaine est un témoignage de l'ingéniosité romaine et s'orne d'une profusion de sculptures et d'hommages symboliques aux divinités anciennes, aux légendes et aux visionnaires romains, ainsi qu'à la luxuriance du monde naturel. Son nom, dérivé de *tre vie* (trois voies), évoque son emplacement stratégique à l'intersection de trois anciennes rues, empruntées autrefois par les pèlerins et les citoyens et aujourd'hui par près de 10 millions de visiteurs chaque année.

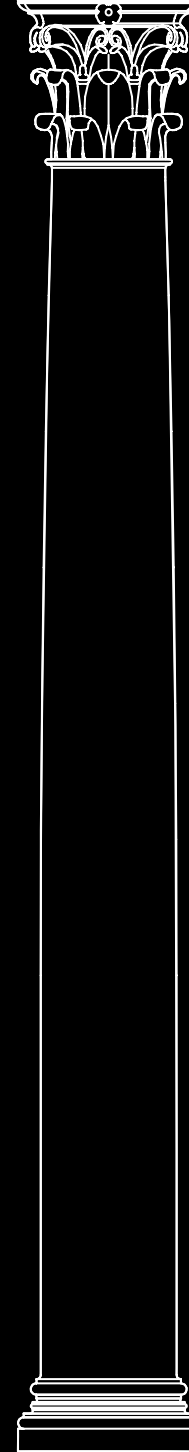

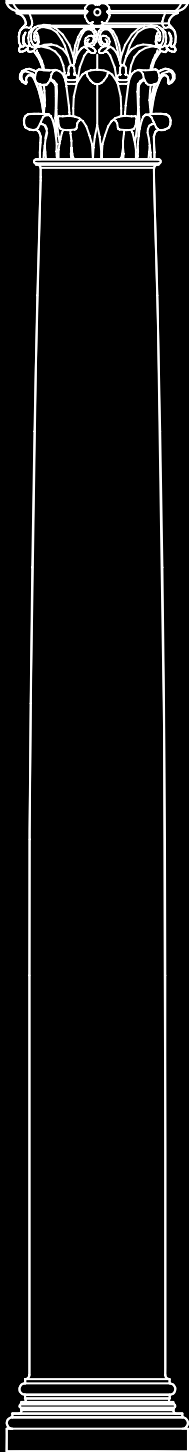

LE MOT DE L'ÉQUIPE DE DESIGNERS LEGO® ARCHITECTURE

Plus qu'un trésor pour les yeux, la fontaine de Trevi est une icône culturelle qui a inspiré d'innombrables œuvres d'art mais aussi la littérature et le cinéma. Après le succès du set LEGO® Architecture La fontaine de Trevi (21020) lancé en 2014, cette version revisite le site à plus grande échelle et se veut une interprétation du monument original, dont certains détails ont été simplifiés pour pouvoir être intégrés au décor.

L'objectif principal était de restituer l'ambiance et l'atmosphère baroques de Rome un jour d'été, lorsque la place, baignée d'une lumière chaude, reflète les bâtiments colorés qui entourent la fontaine de Trevi. Les renforcements créent des jeux d'ombre sur la façade et sur le bassin ainsi que de subtiles variations de couleurs sur la surface. En utilisant des tons roses, beiges, gris et blancs, nous avons voulu restituer l'essence de ces nuances complexes sur le bâtiment, les statues, l'eau et les rochers.



Mary Wilson
Designer LEGO® Architecture



PALAIS POLI

Les armoiries du pape Clément XII, commanditaire de la fontaine de Trevi, sont flanquées de quatre statues représentant des récoltes et des fruits fertilisés par l'eau.



OCEANUS (NEPTUNE)

Le dieu des océans, conduisant un char en forme de coquillage tiré par des chevaux marins mythiques (hippocampes), symbolise l'expertise technique des Romains, maîtres dans le contrôle et l'acheminement de l'eau via des aqueducs.

AGRIPPA

Le général et architecte romain Marcus Vipsanius Agrippa (63-12 avant notre ère) est illustré en train d'approuver les plans de construction de l'aqueduc d'origine.



LA VIERGE

Un hommage à la jeune fille qui, selon la légende, indiqua l'emplacement de la source aux soldats romains il y a des millénaires.



LA SALUBRITÉ (SALUS)

La déesse de la santé tient une coupe pour abreuver un serpent, symbolisant la pureté et les vertus curatives de l'eau.



ABUNDANTIA

La déesse de l'abondance fait couler de l'eau d'une grande urne, symbolisant l'eau acheminée par les aqueducs et la fertilité qu'elle apporte à la terre.



LES TRITONS

Créatures marines mythiques, mi-hommes, mi-poissons. L'une lutte pour contrôler un hippocampe sauvage (la nature turbulente de la mer), l'autre guide un hippocampe calme (les eaux contrôlées par les Romains).



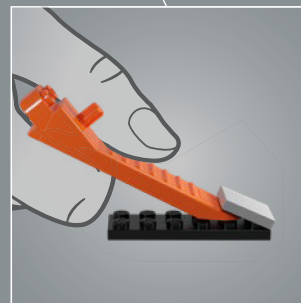
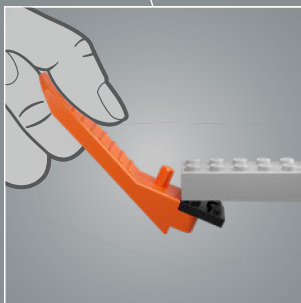
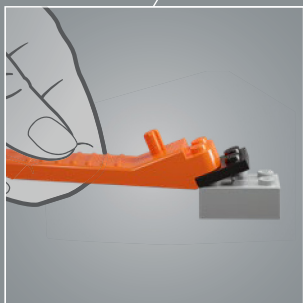
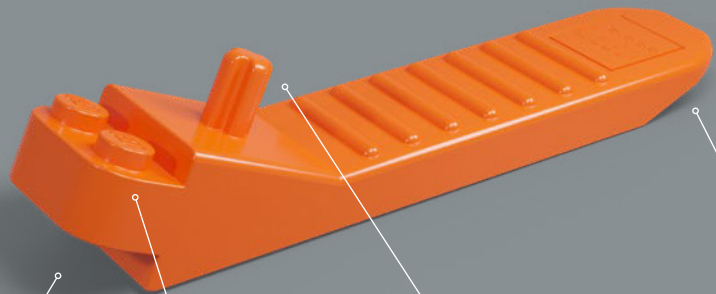



Conçue par Nicola Salvi, la fontaine de Trevi fut construite en 30 ans et terminée par son ami, le sculpteur Pietro Bracci, en 1762, soit 11 ans après la mort de Salvi.

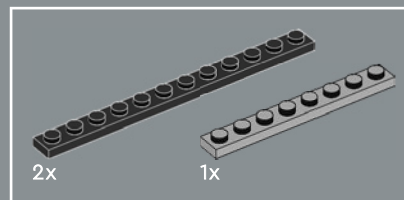

1

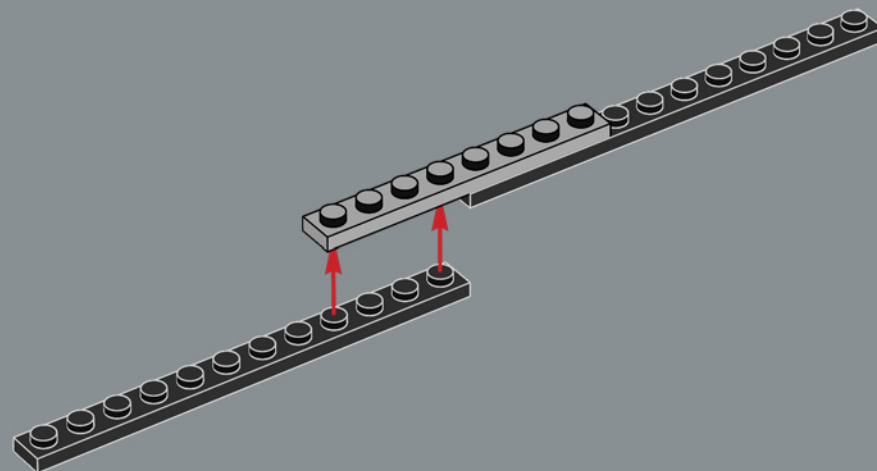

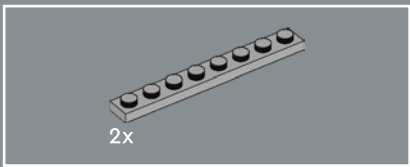

2

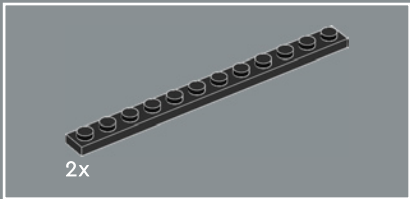
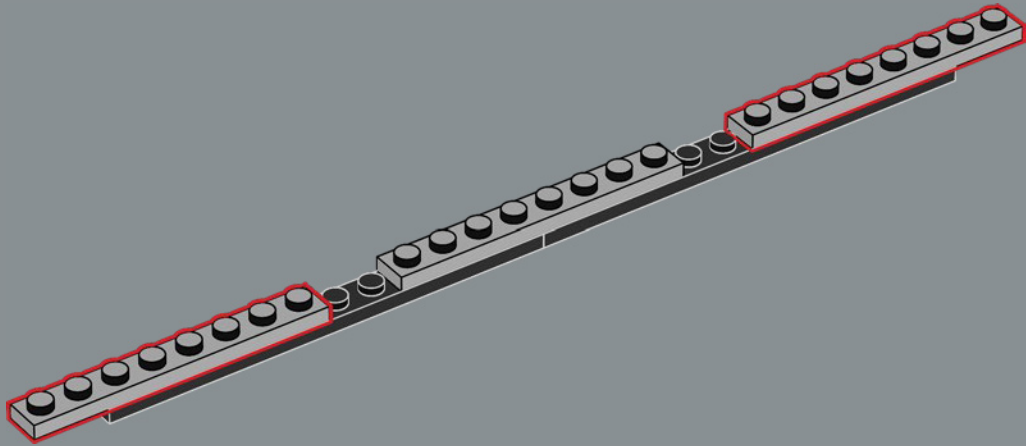

3

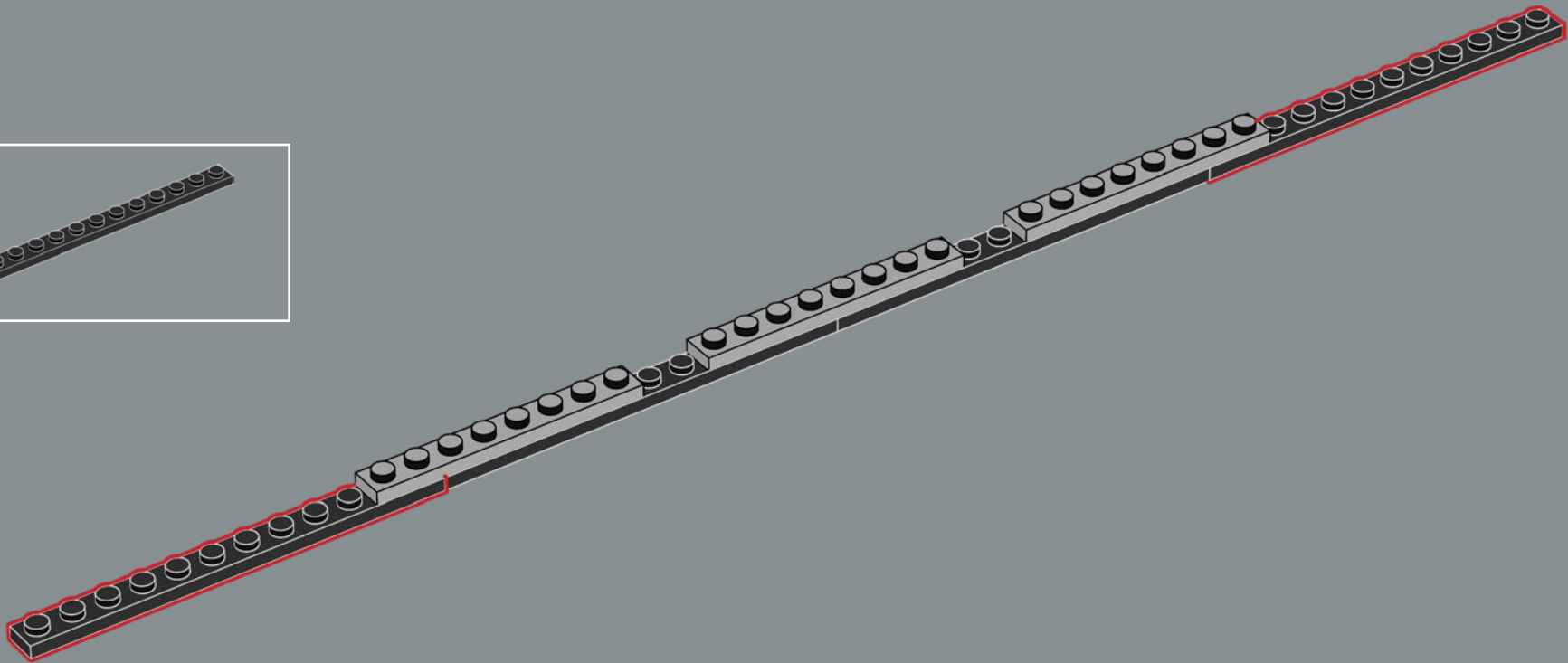

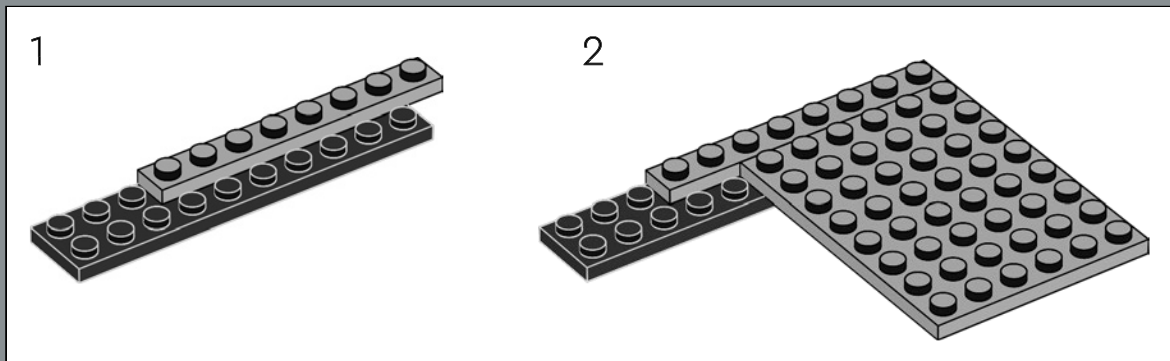
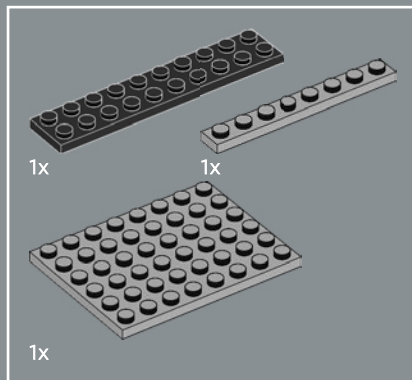

4

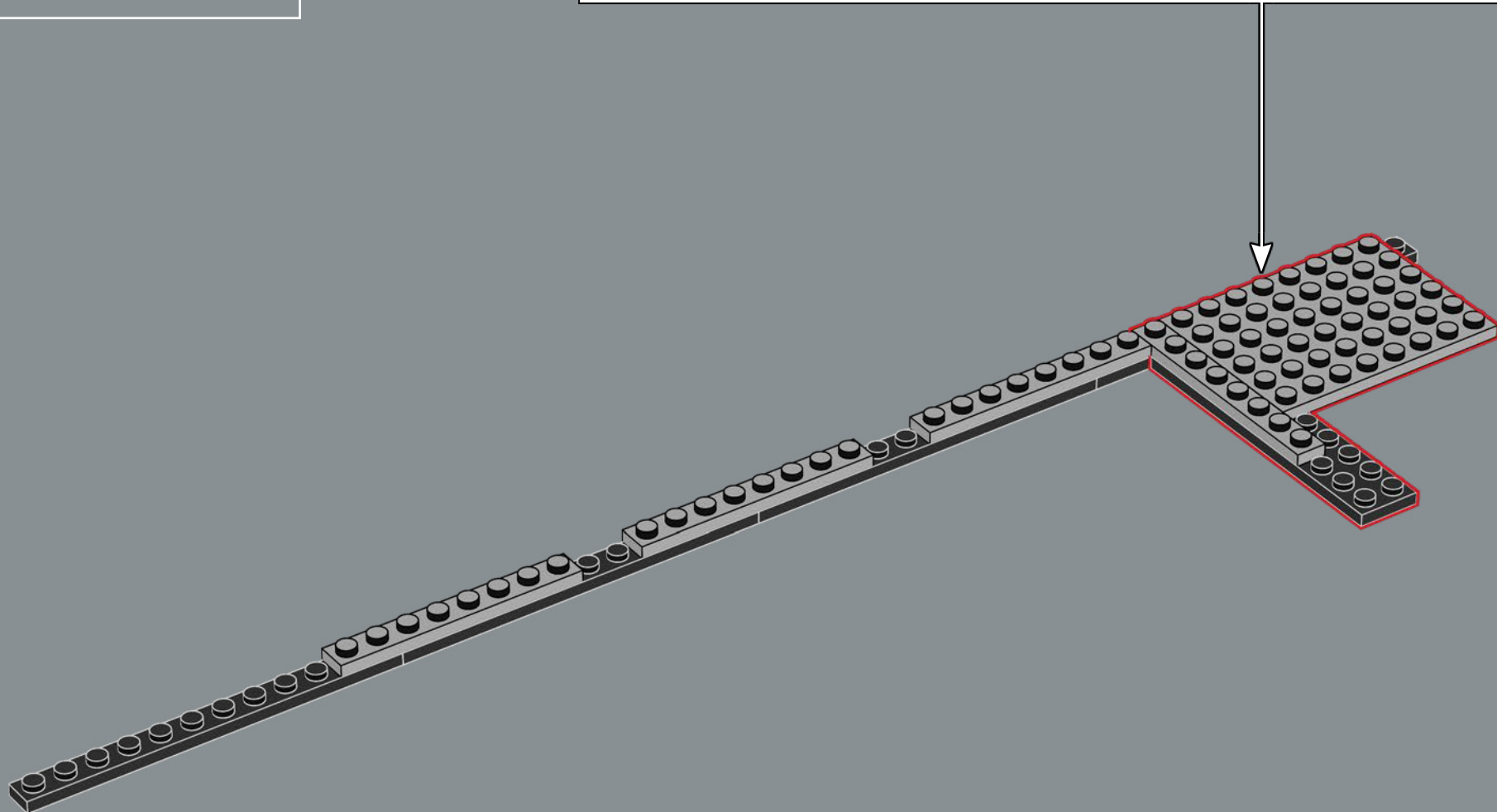

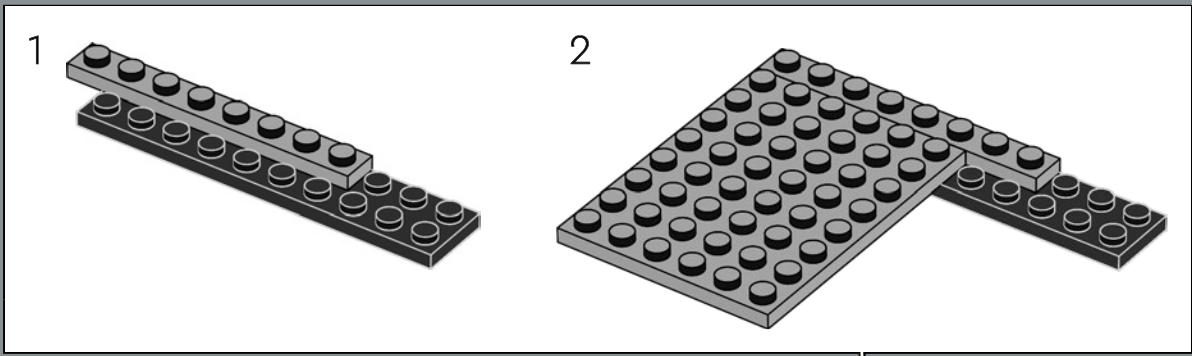
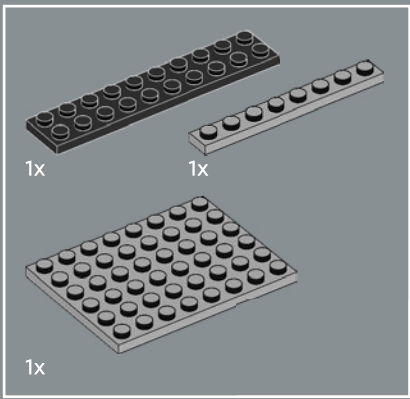

5

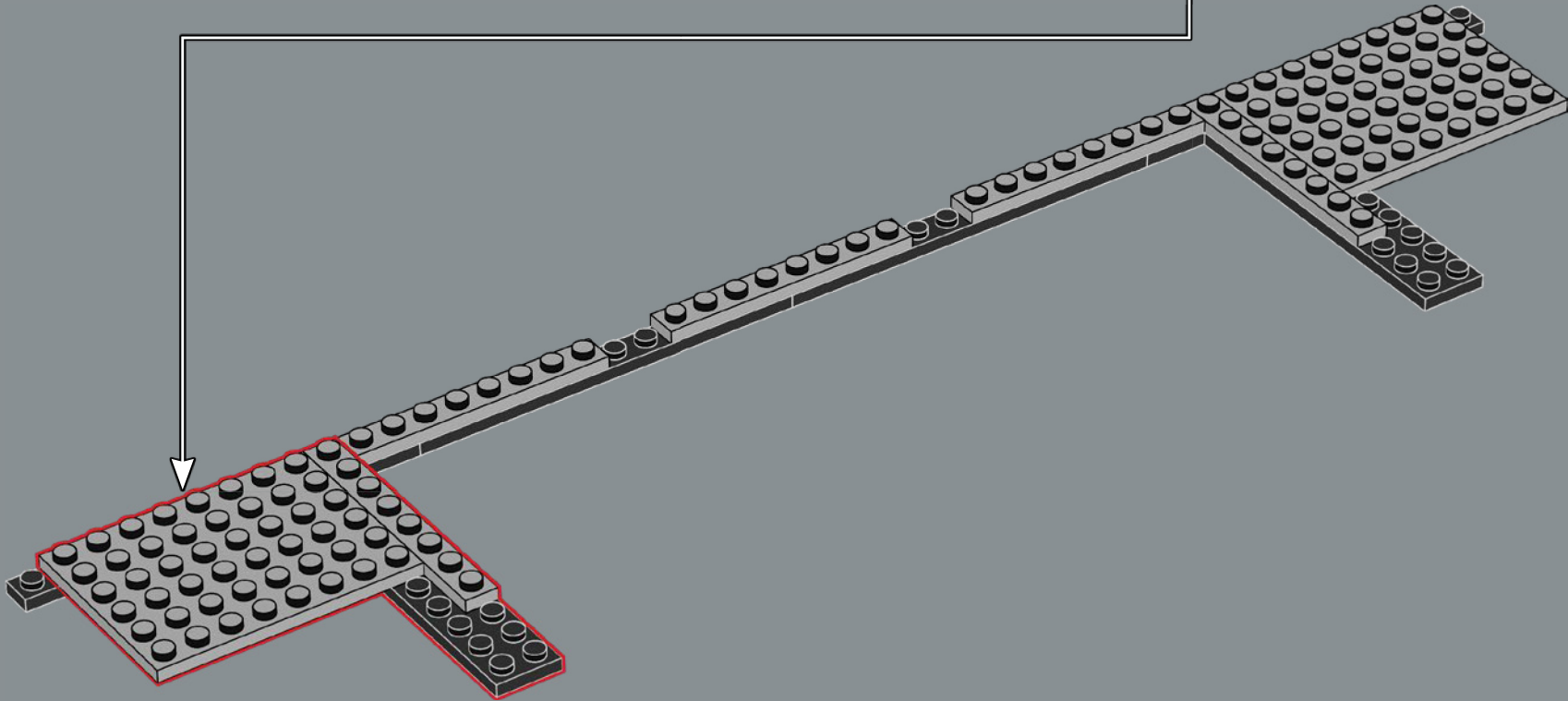

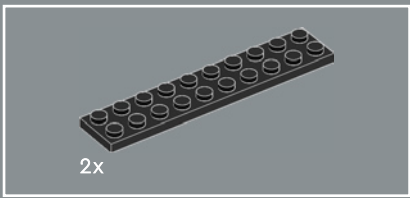

6

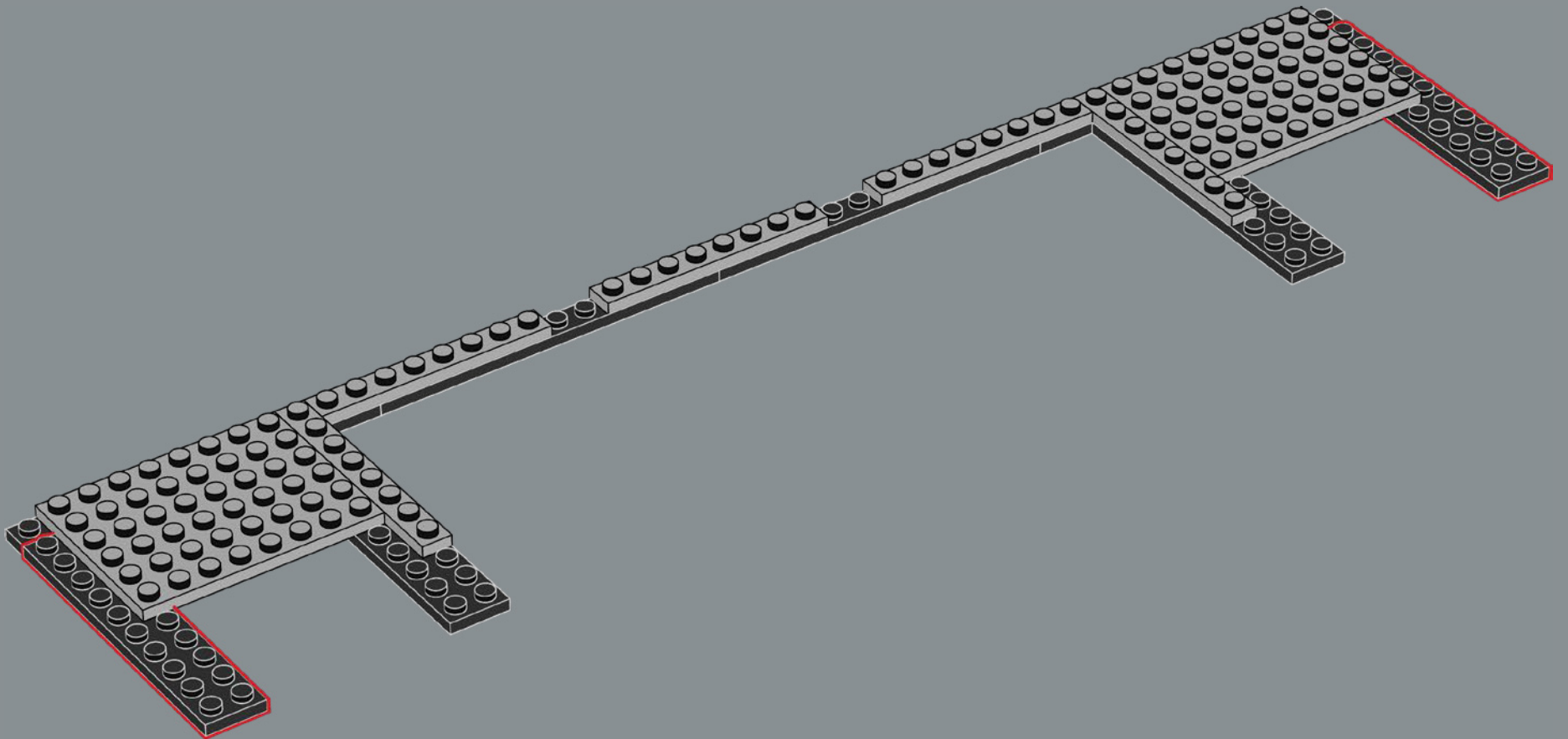

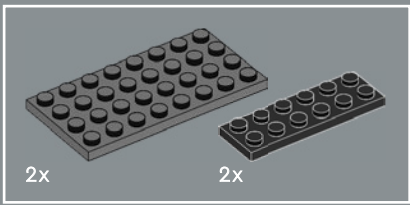

7

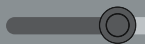
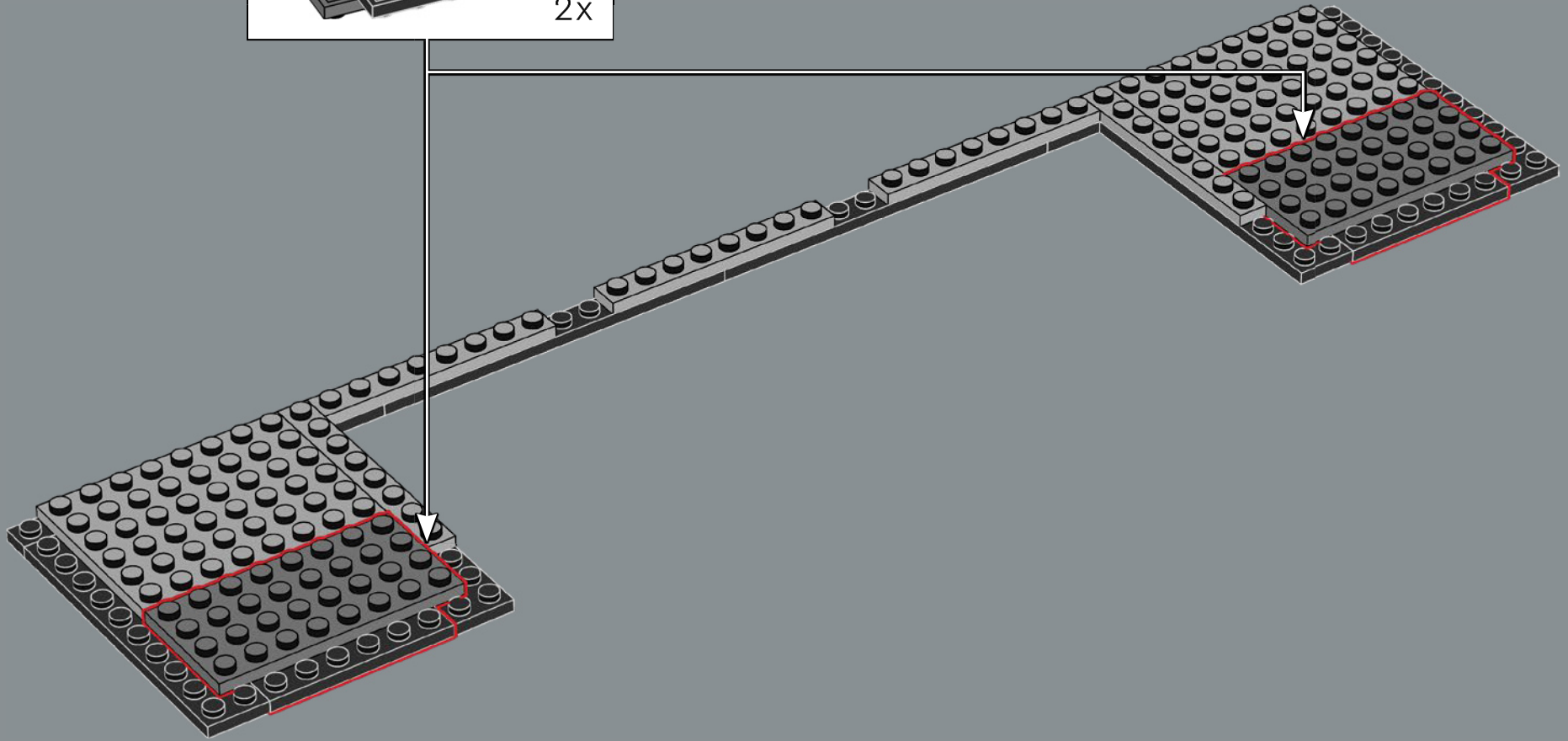
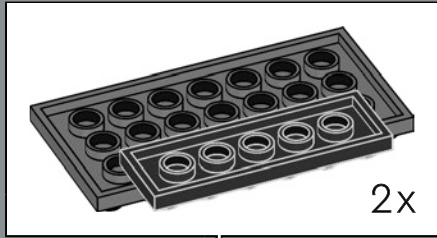

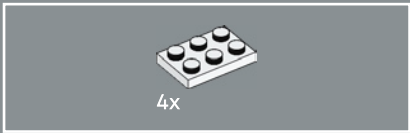

8

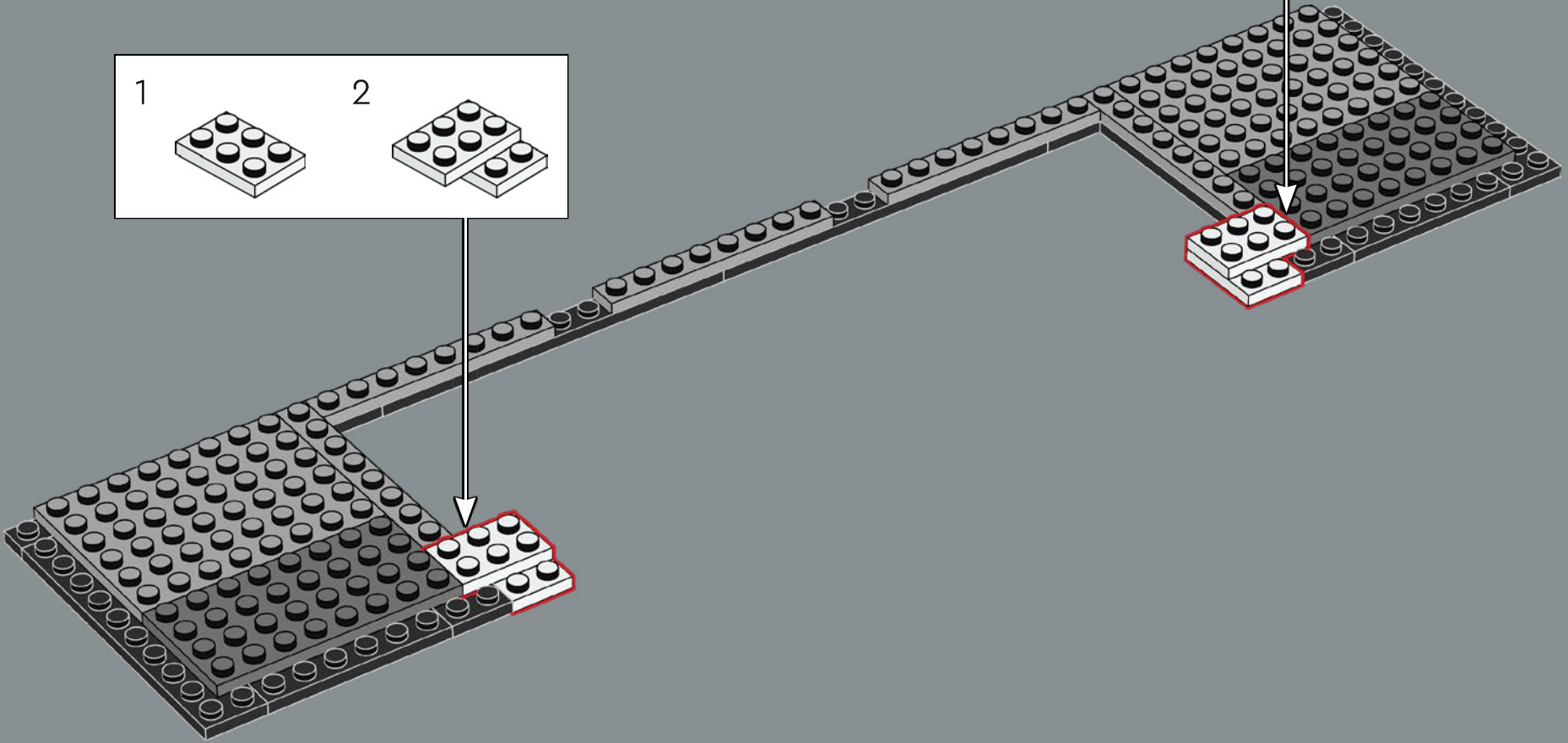
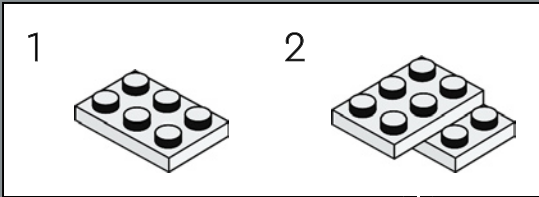
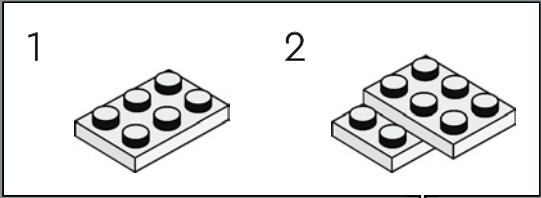

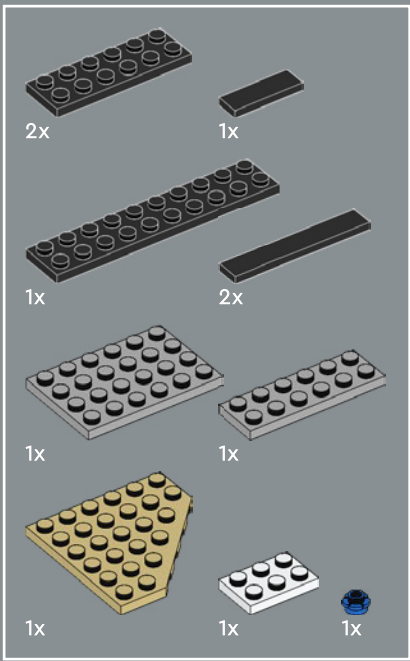

9

1

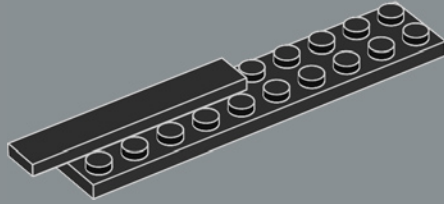

2

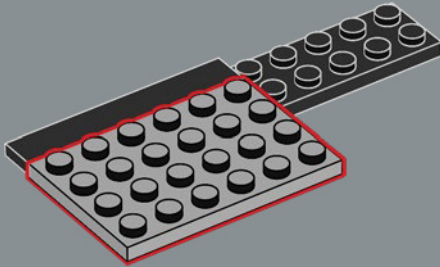

3

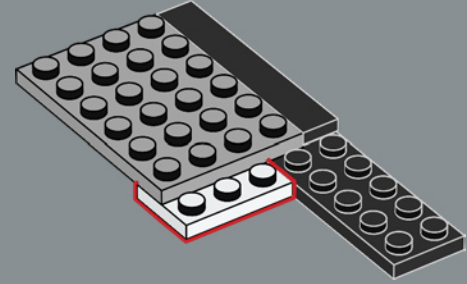

4

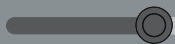
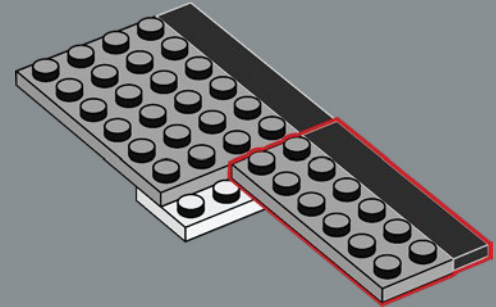

5

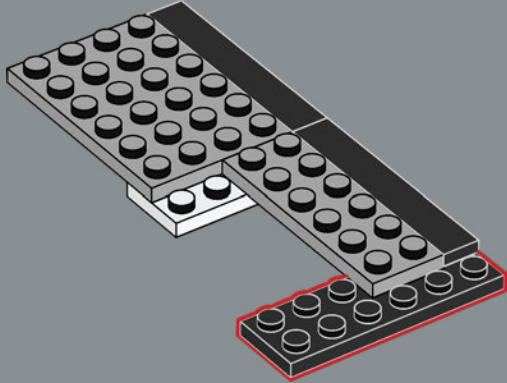

6

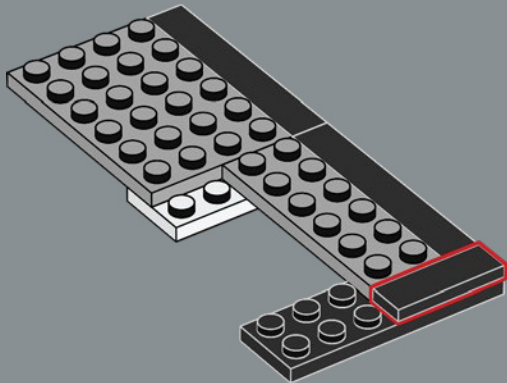

7

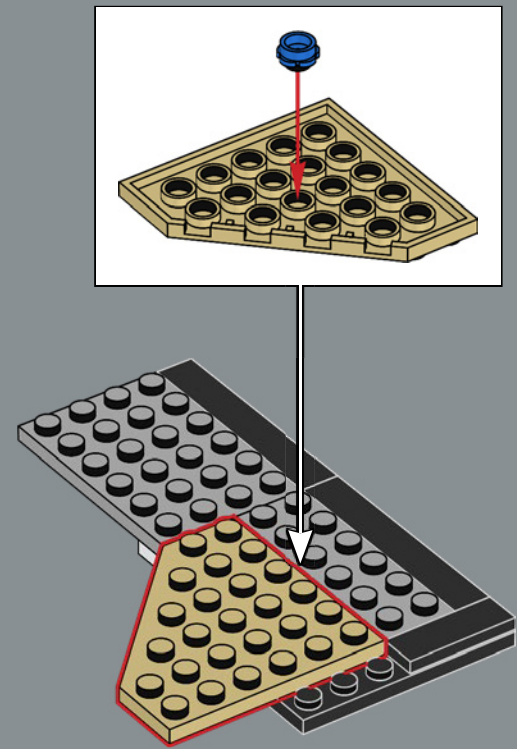

8

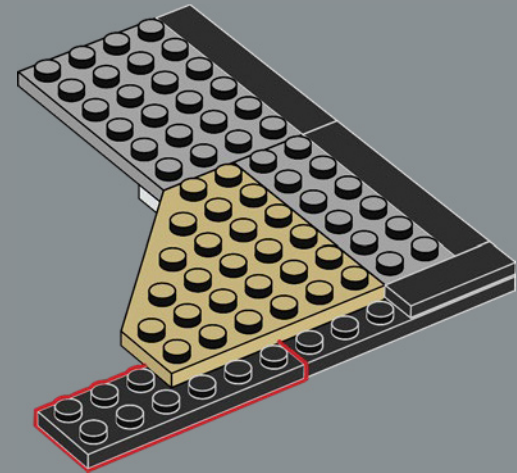

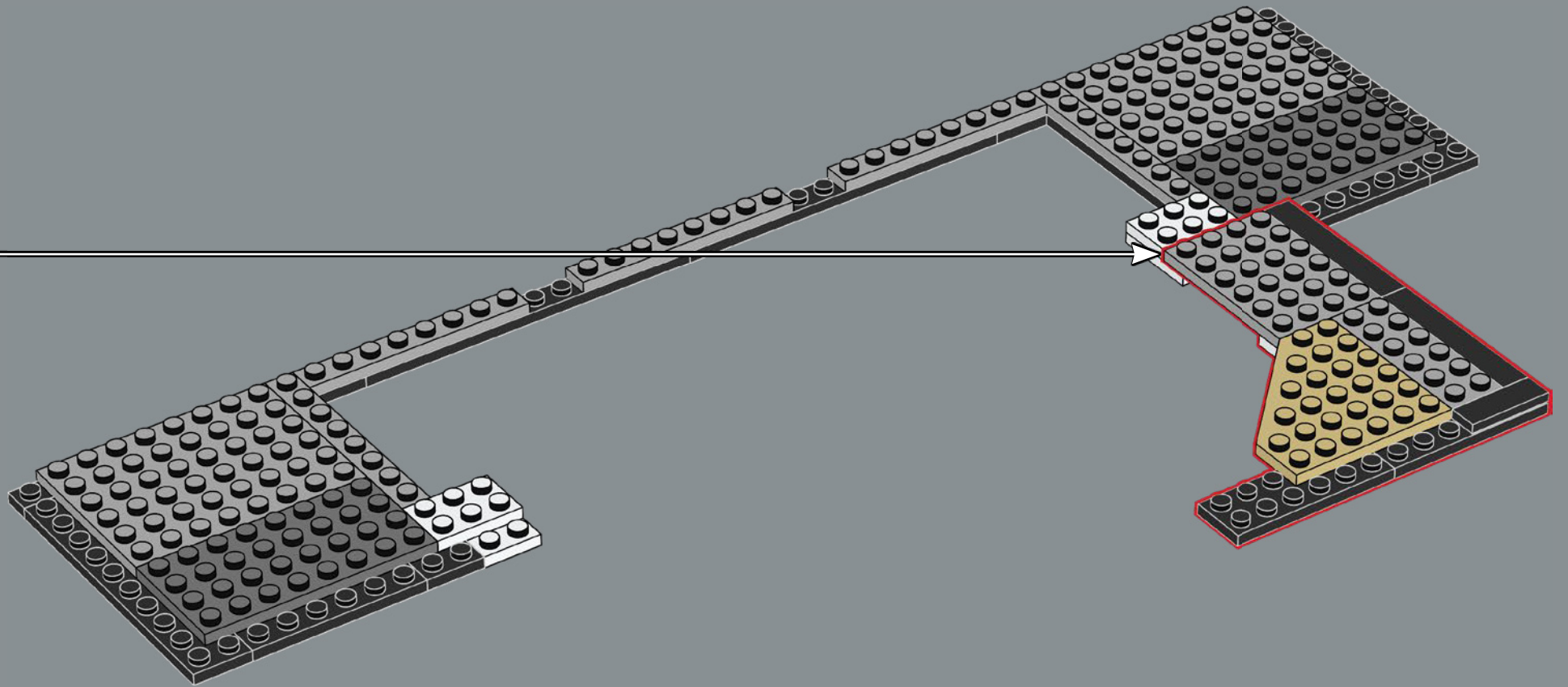

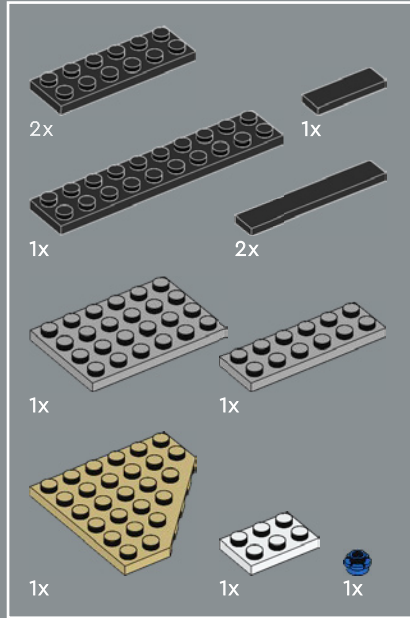
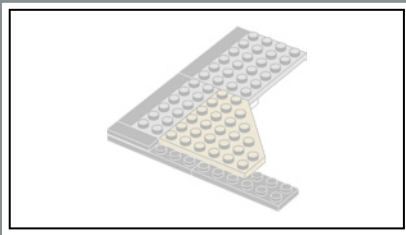

10

1

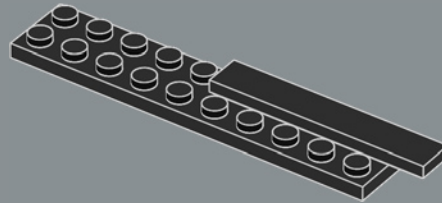

2

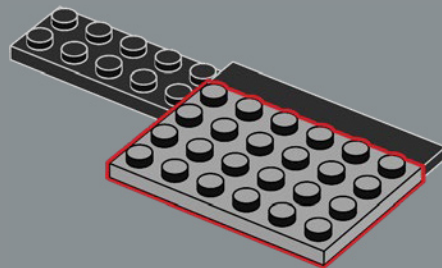

3

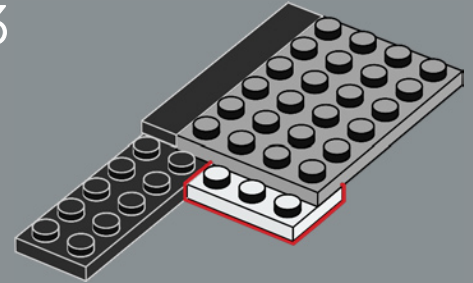

4

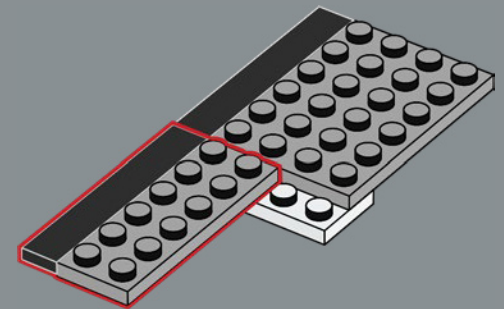

5

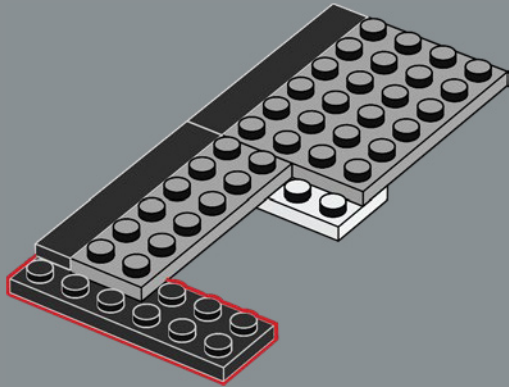

6

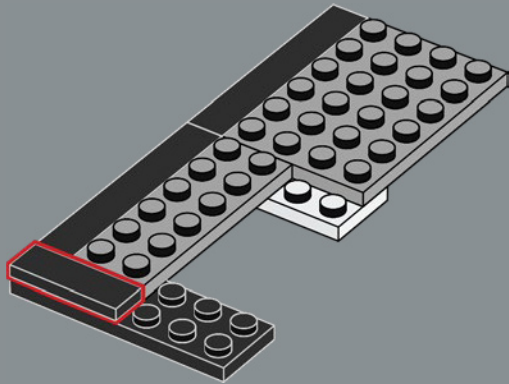

7

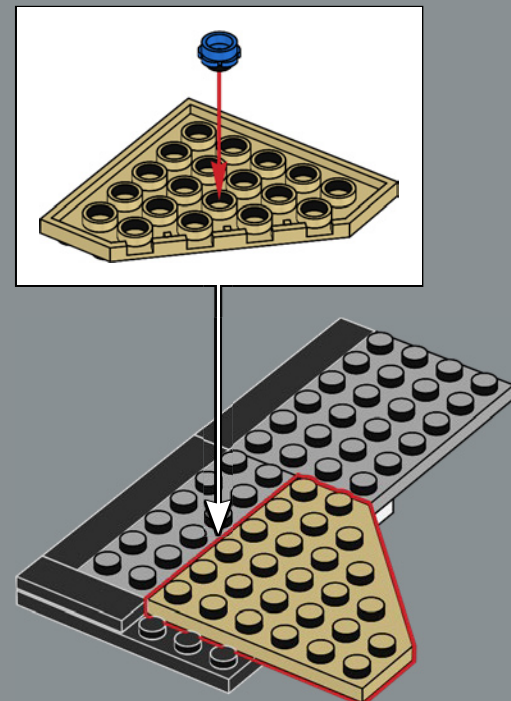

8

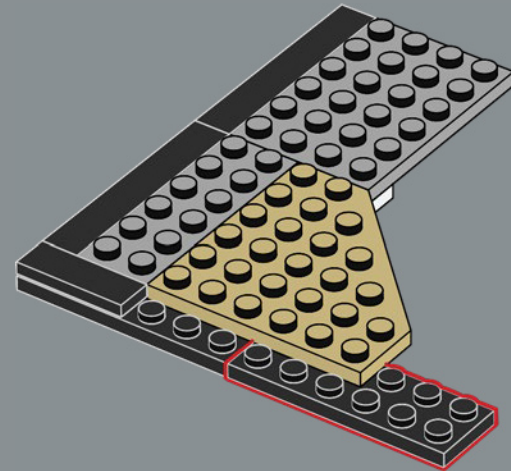

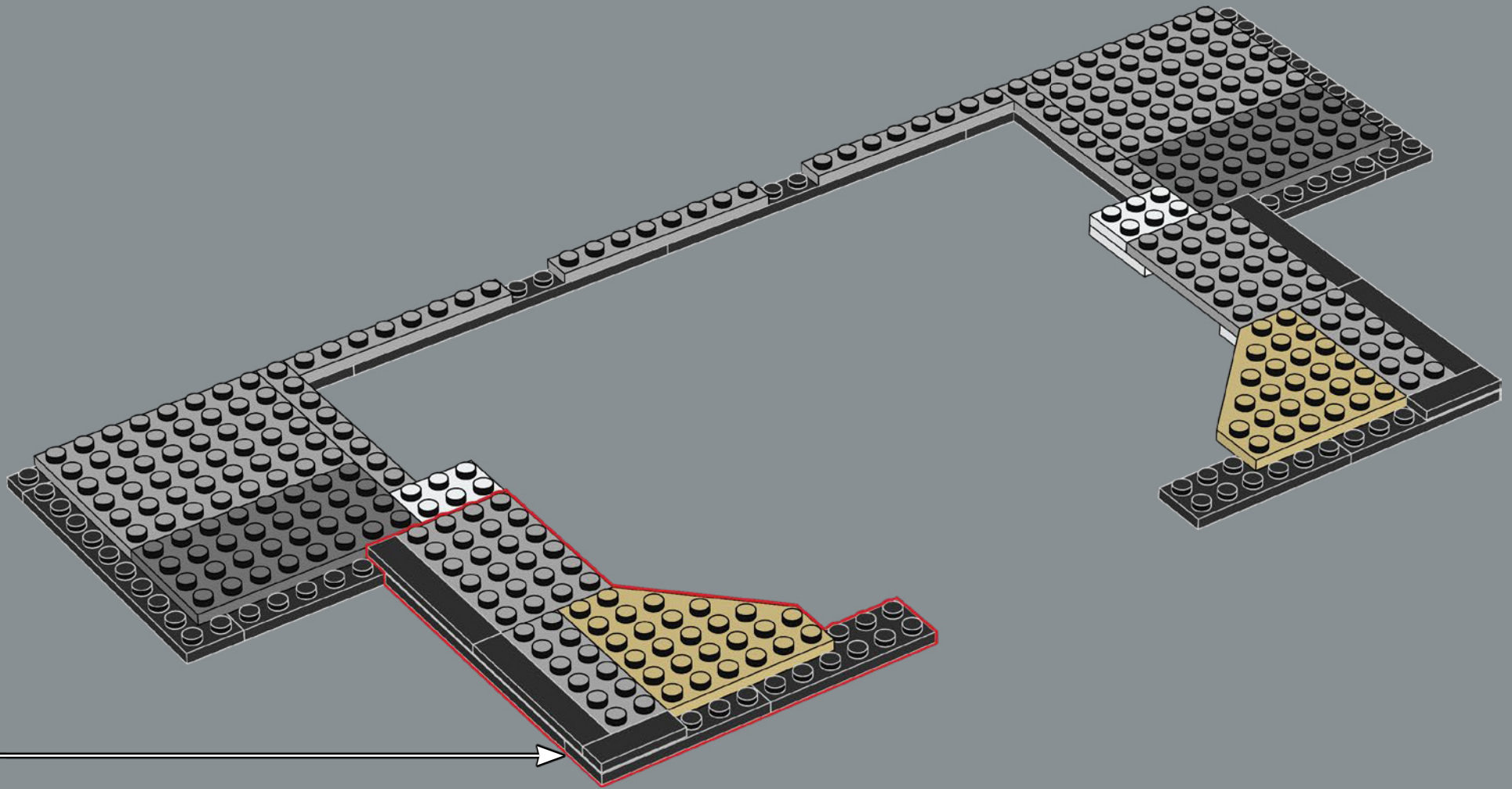

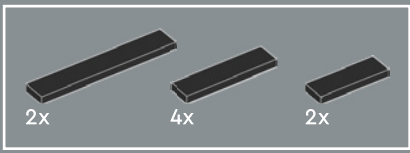

11

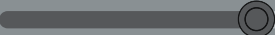
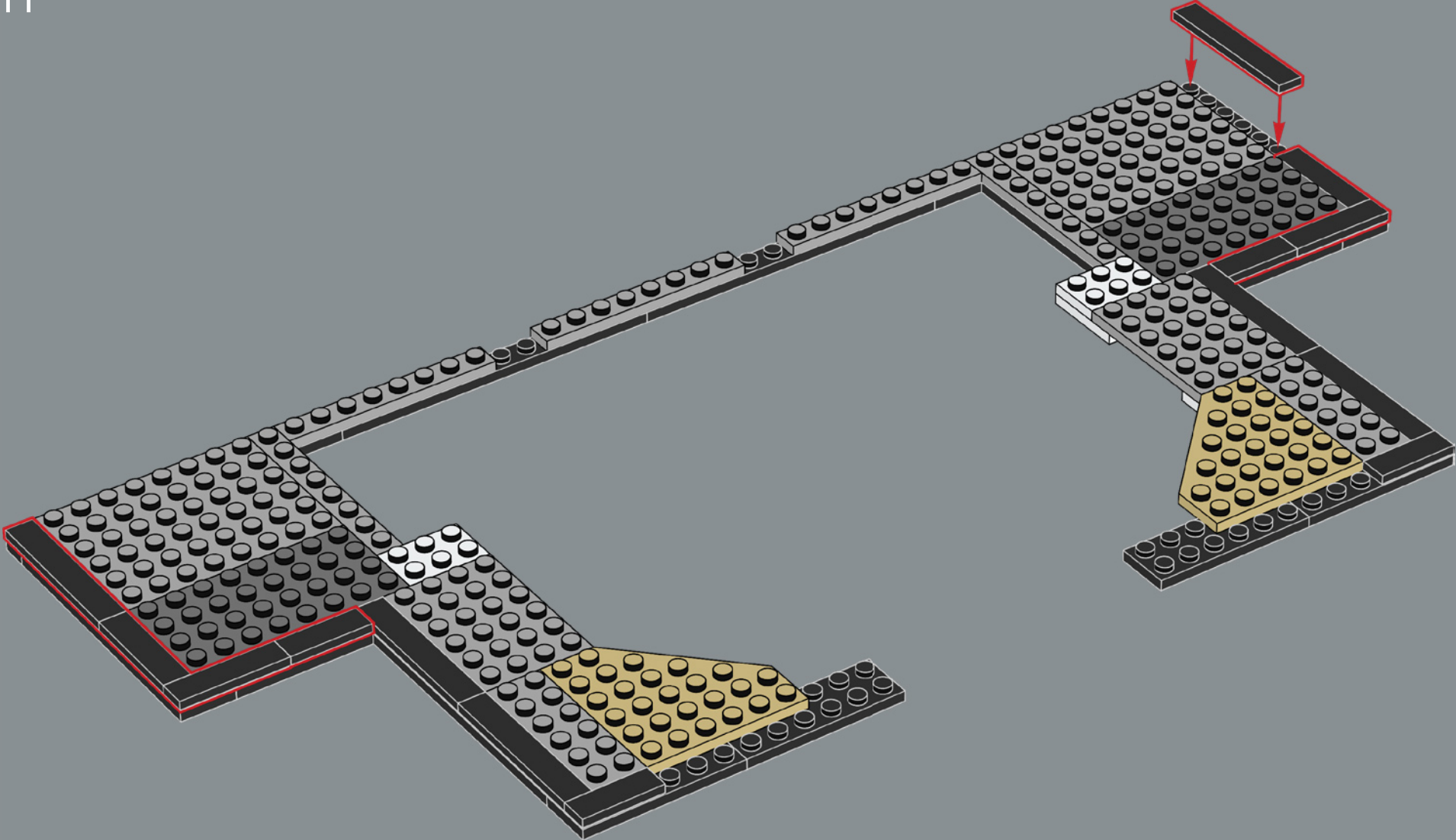

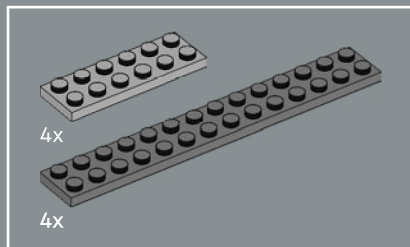

12

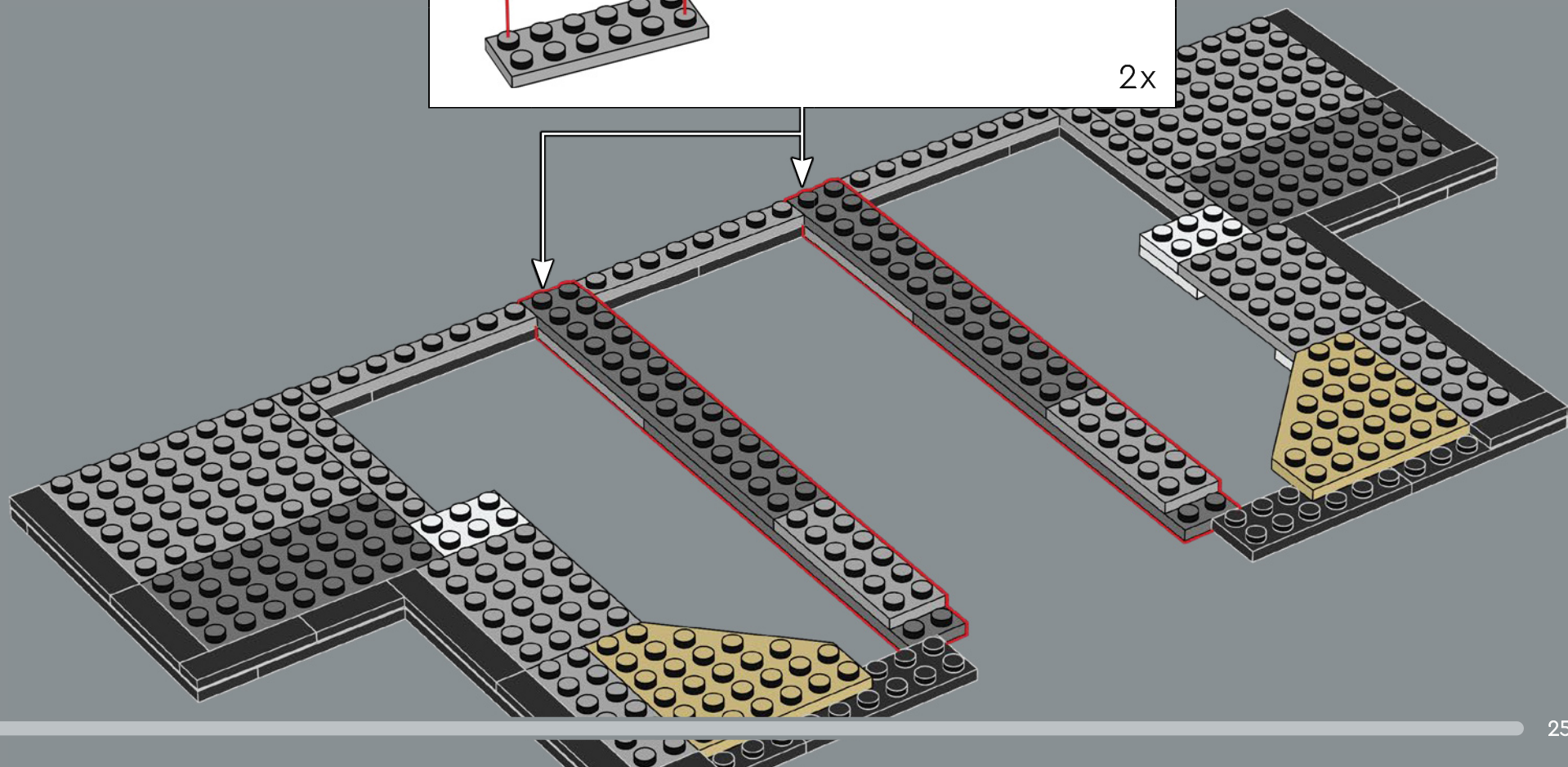
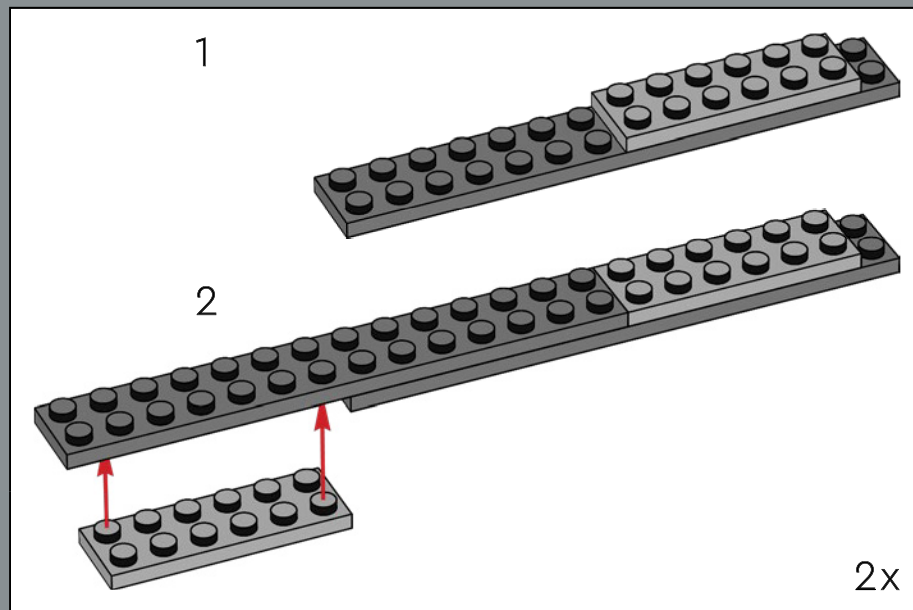

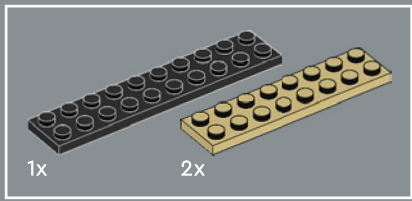

13

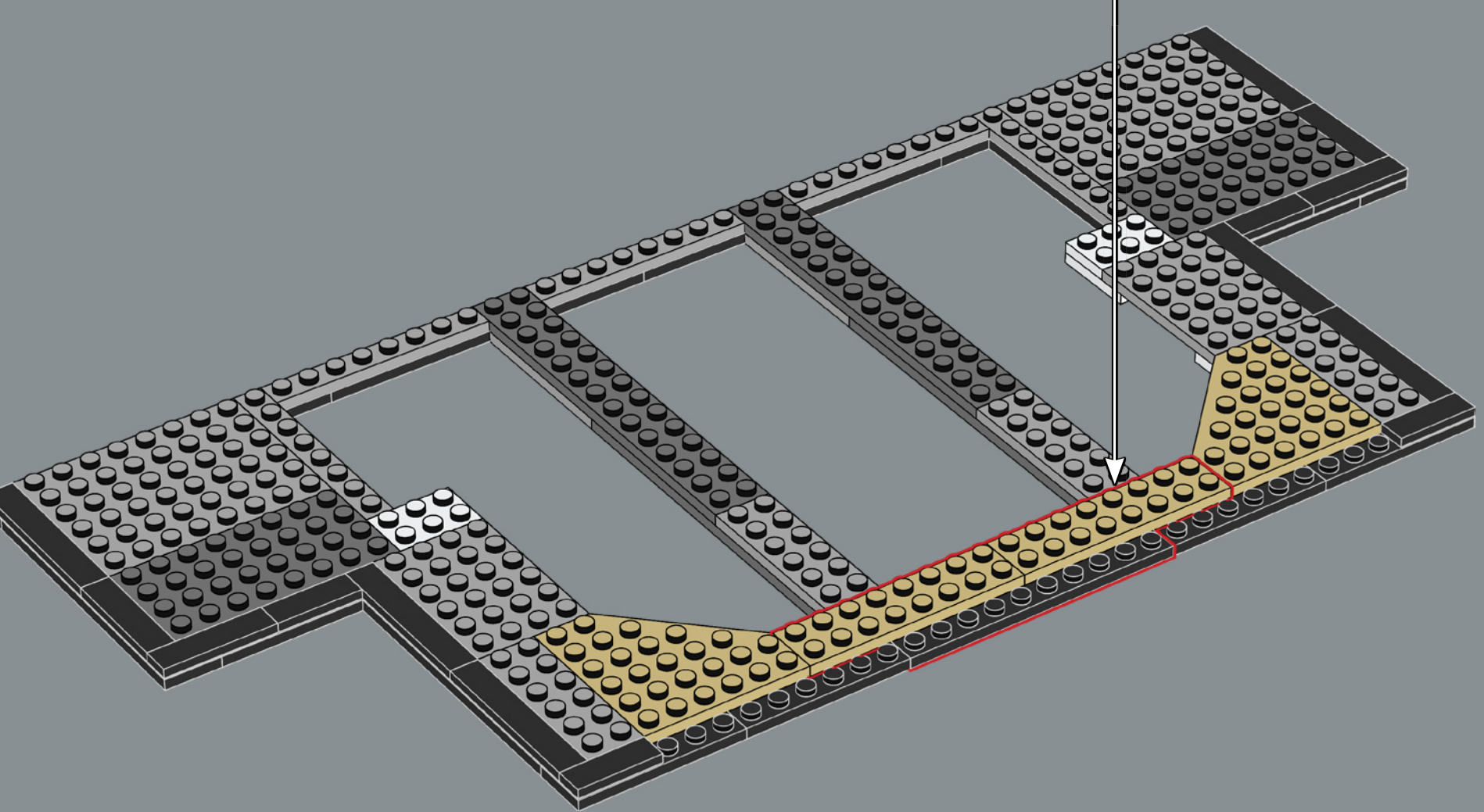
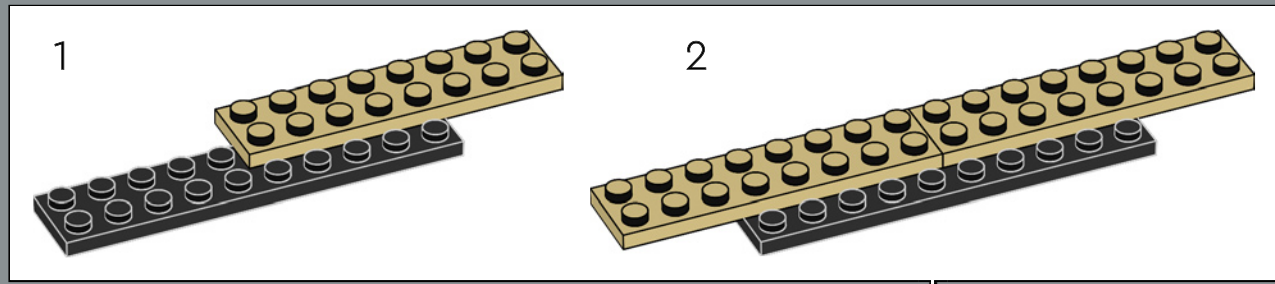

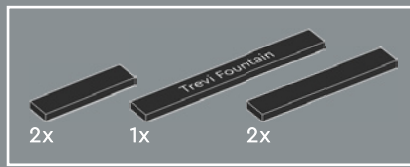

Au fil des siècles, les « trois voies » qui menaient à la fontaine de Trevi et ont inspiré son nom se sont développées. Cinq rues mènent aujourd'hui à la célèbre place.

14

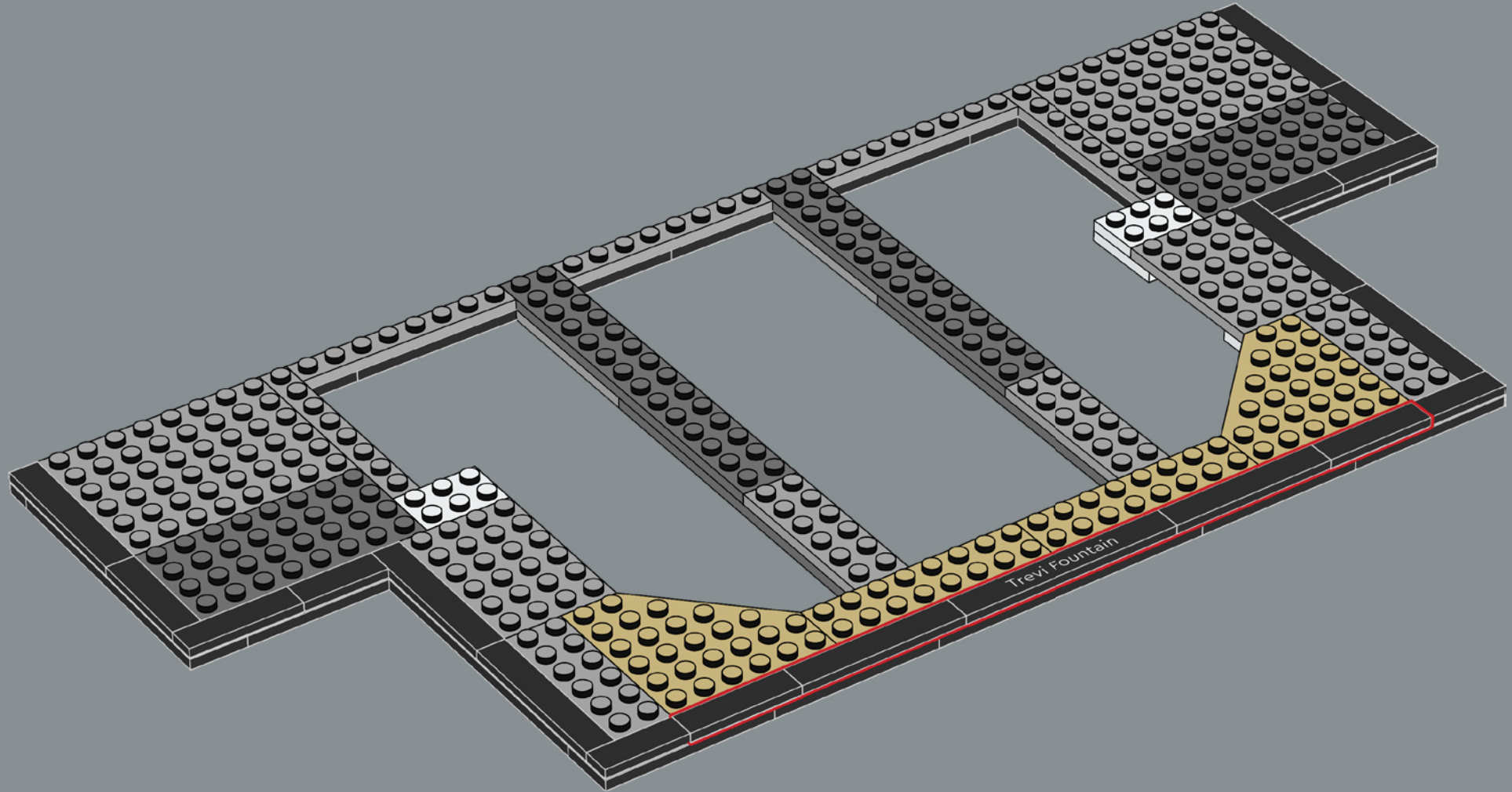

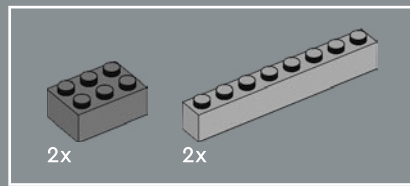

15

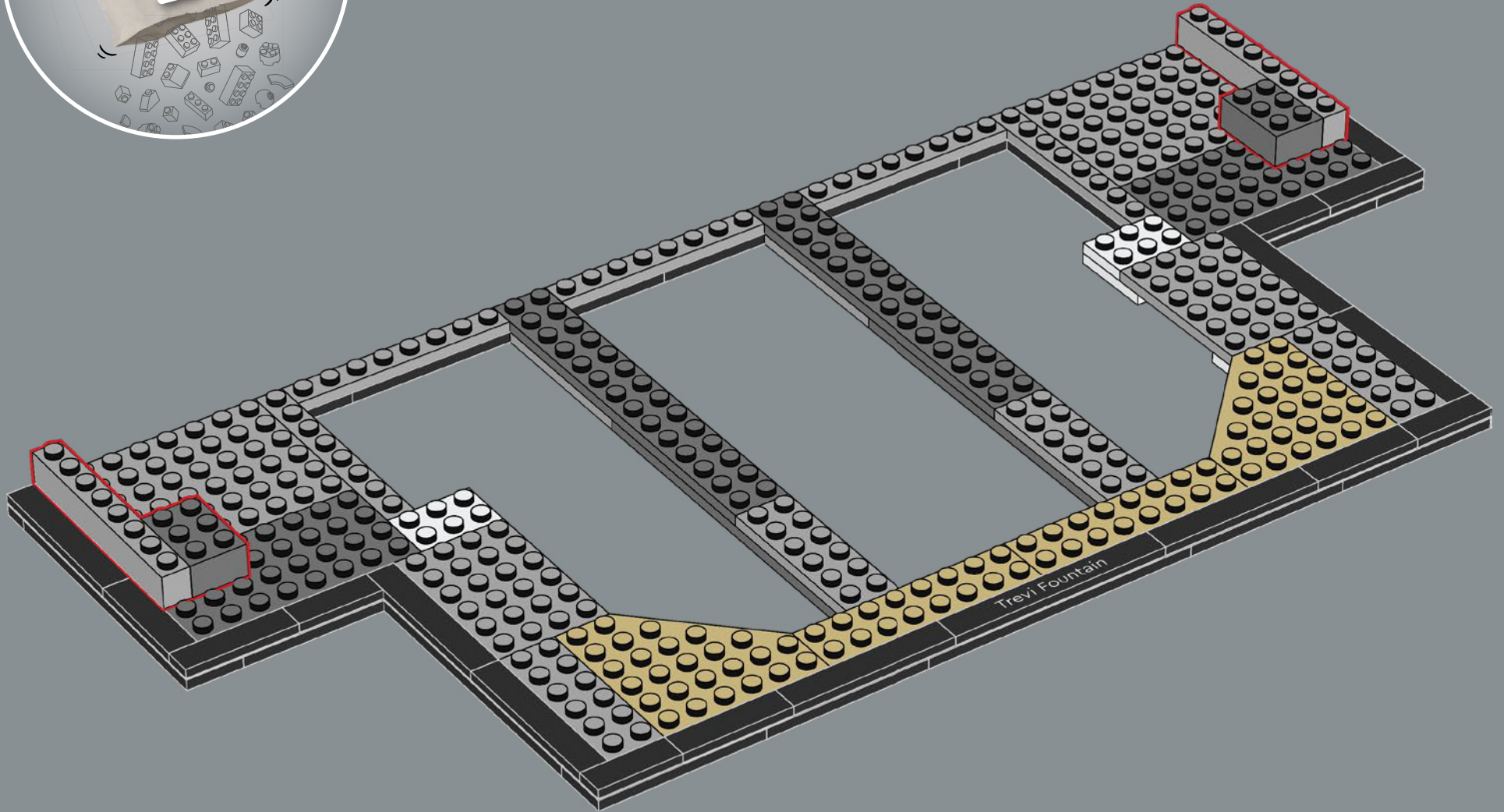

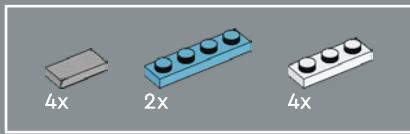

16

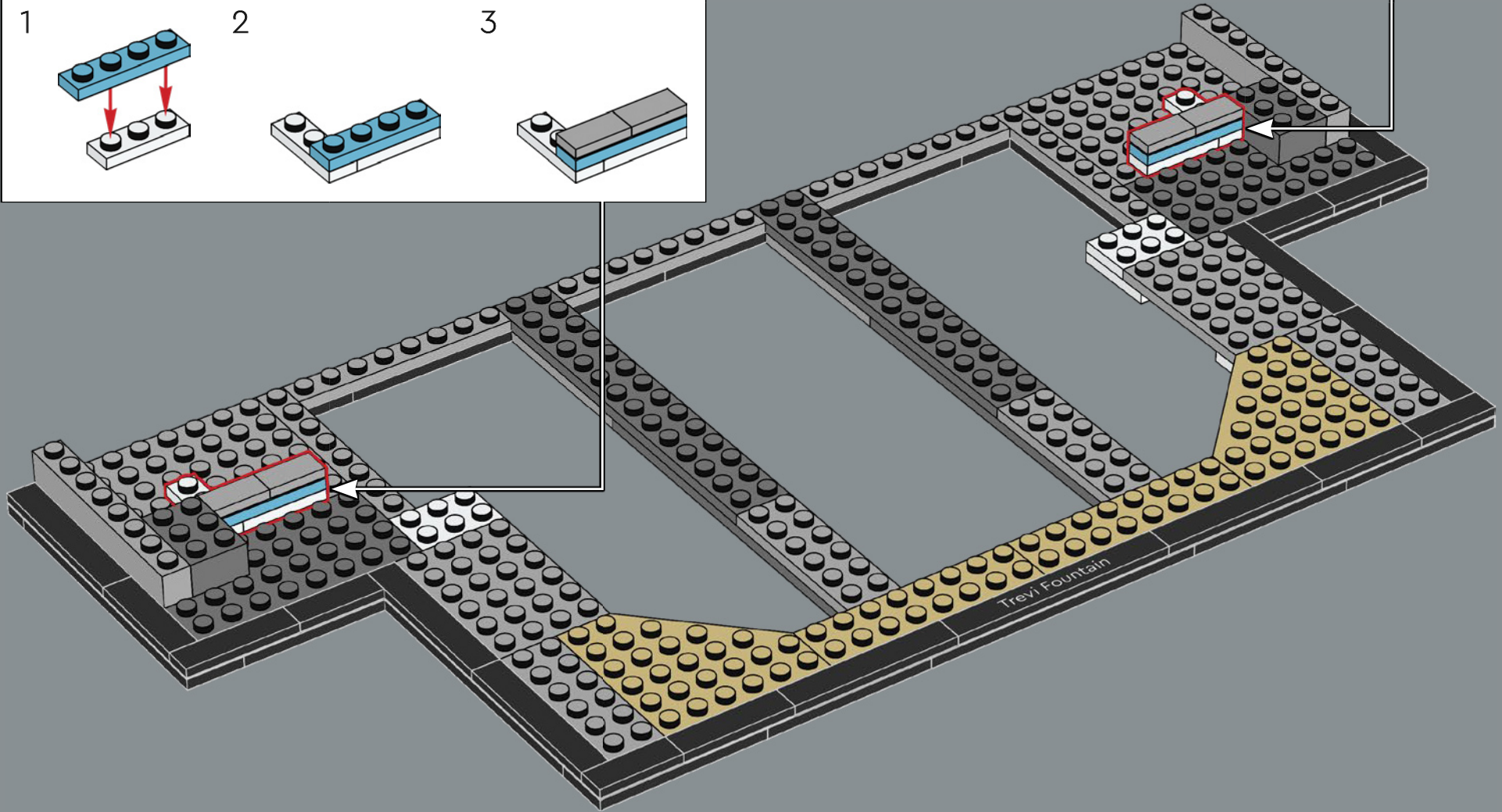
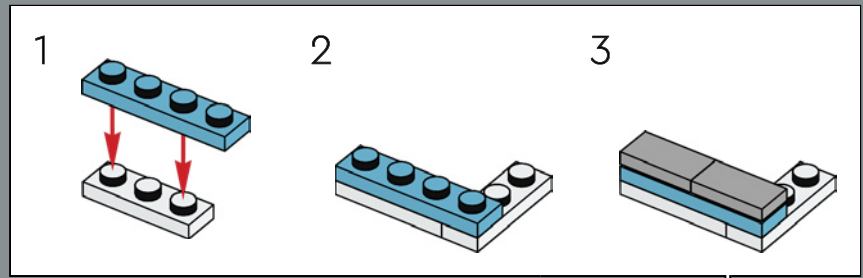
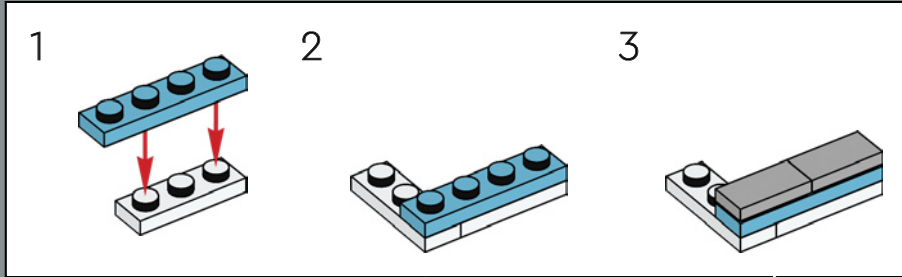

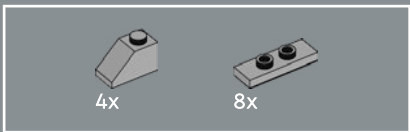

17

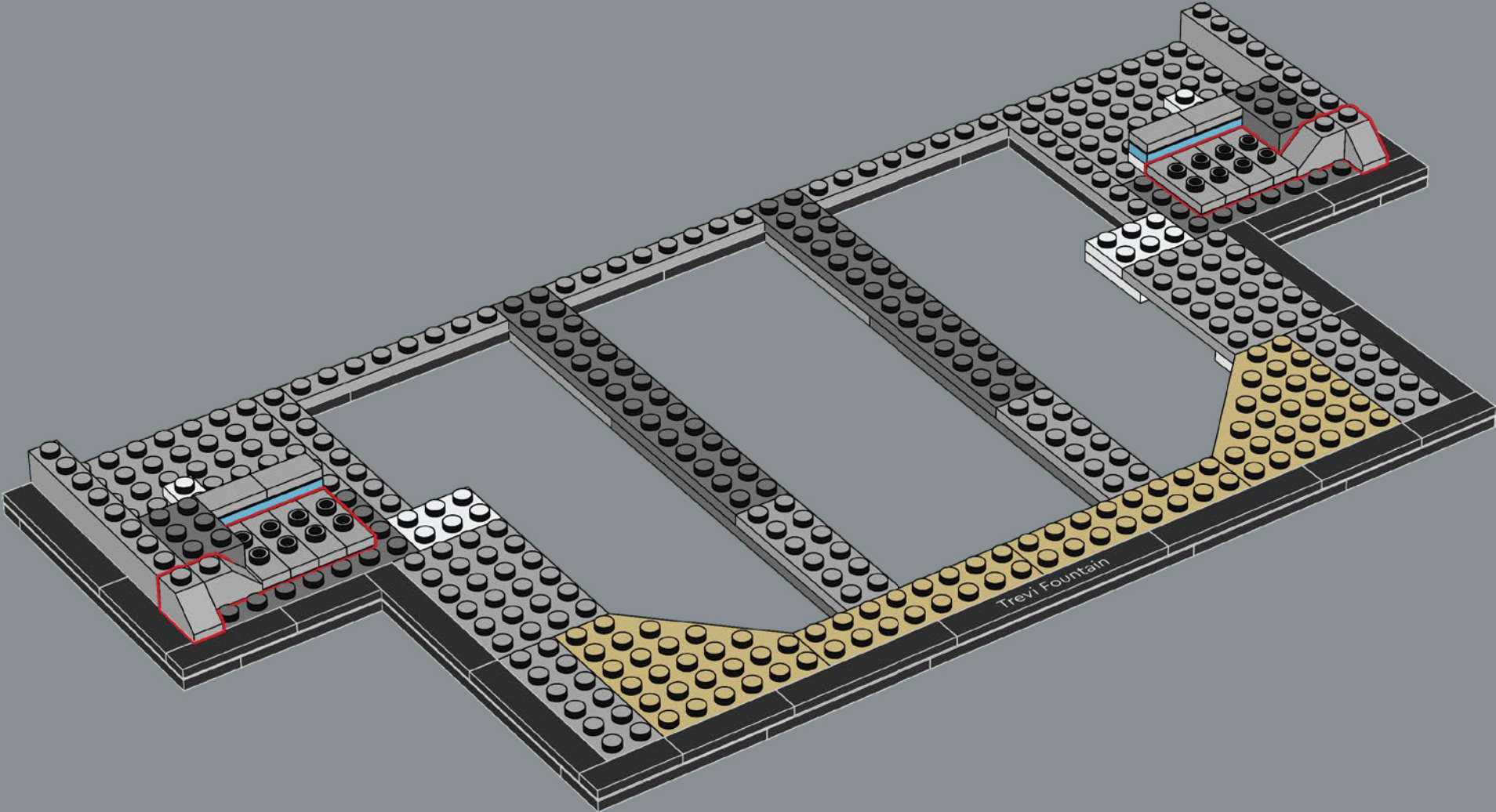

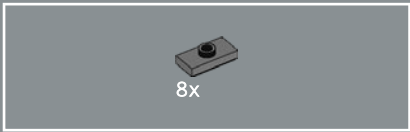

18

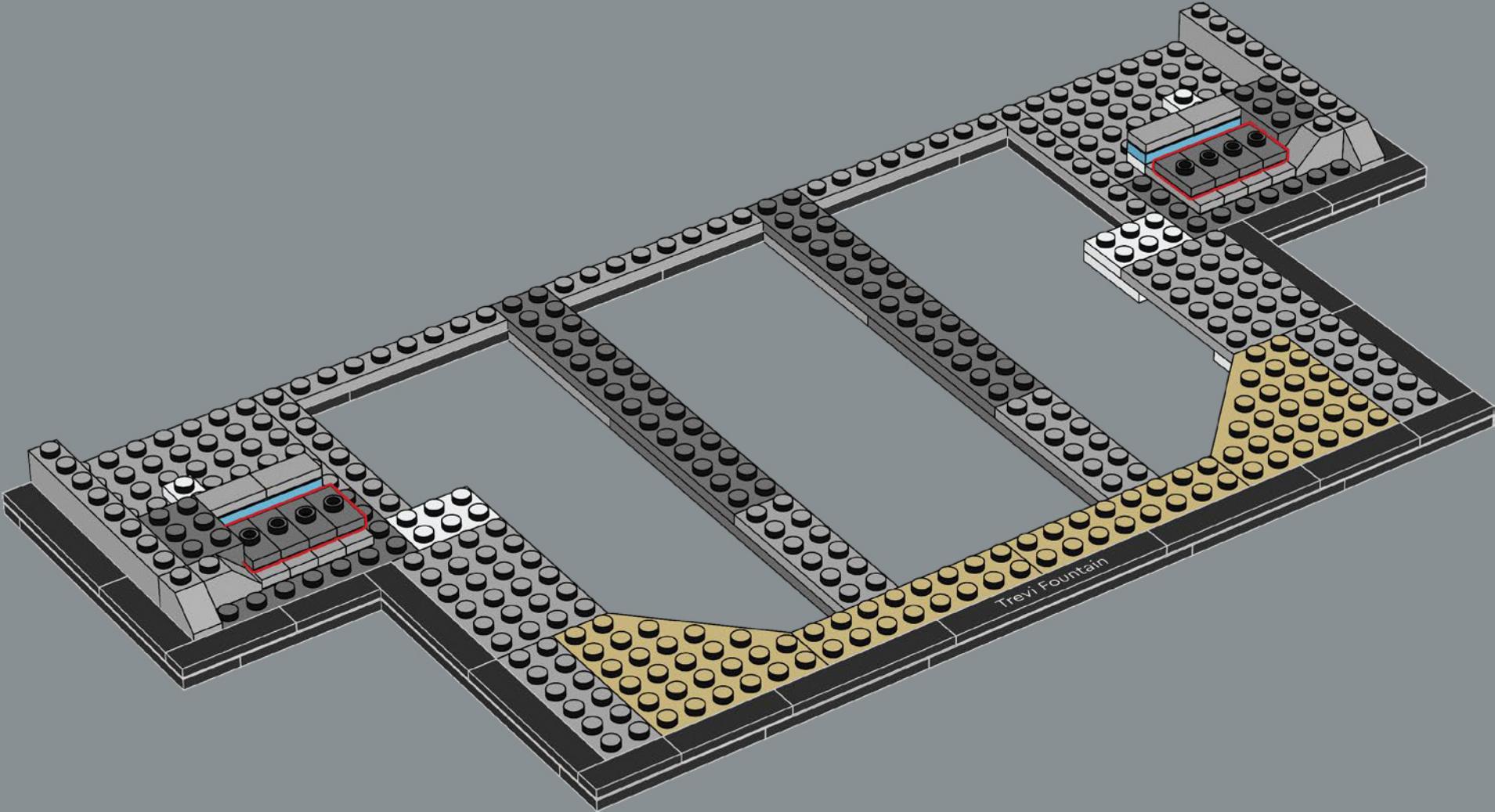



8x

19

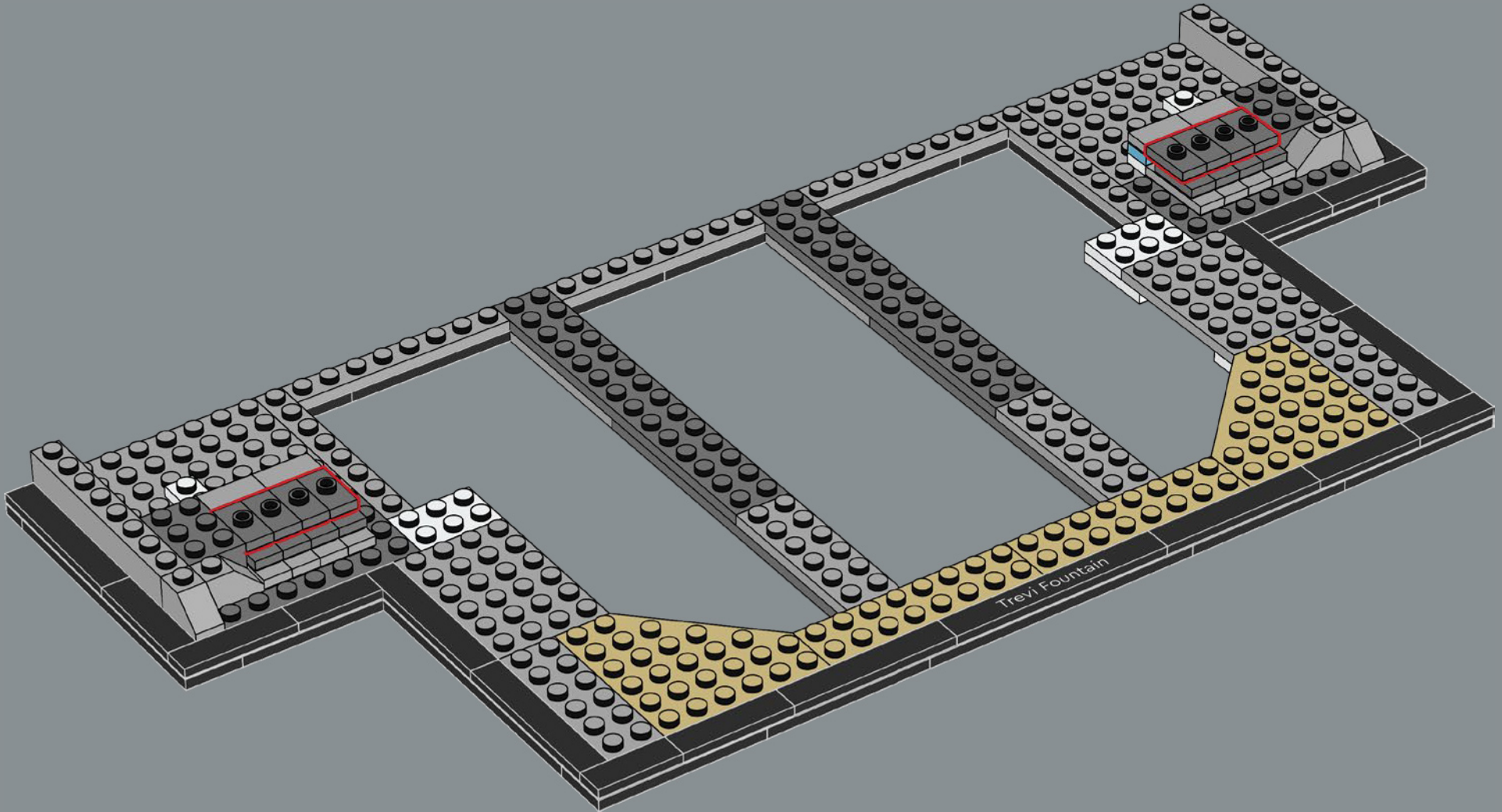

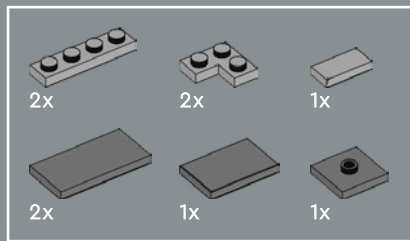

La forte fréquentation du site contribue également à la décoloration progressive du trottoir, des marches et des rochers des niveaux inférieurs.

20

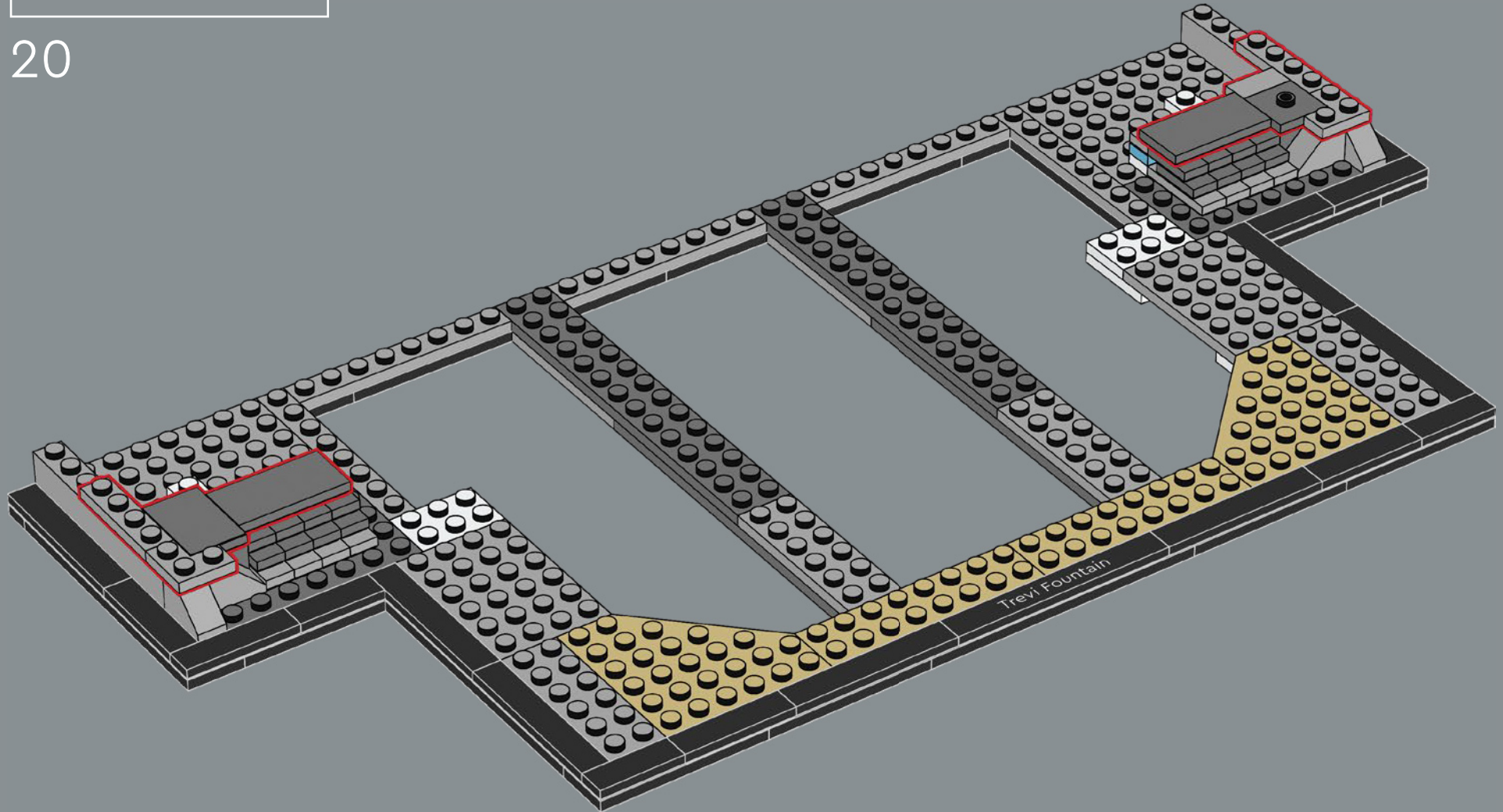

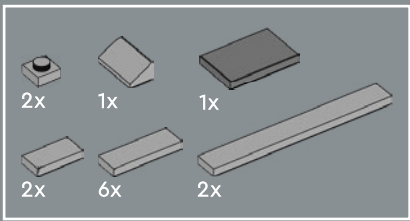

21

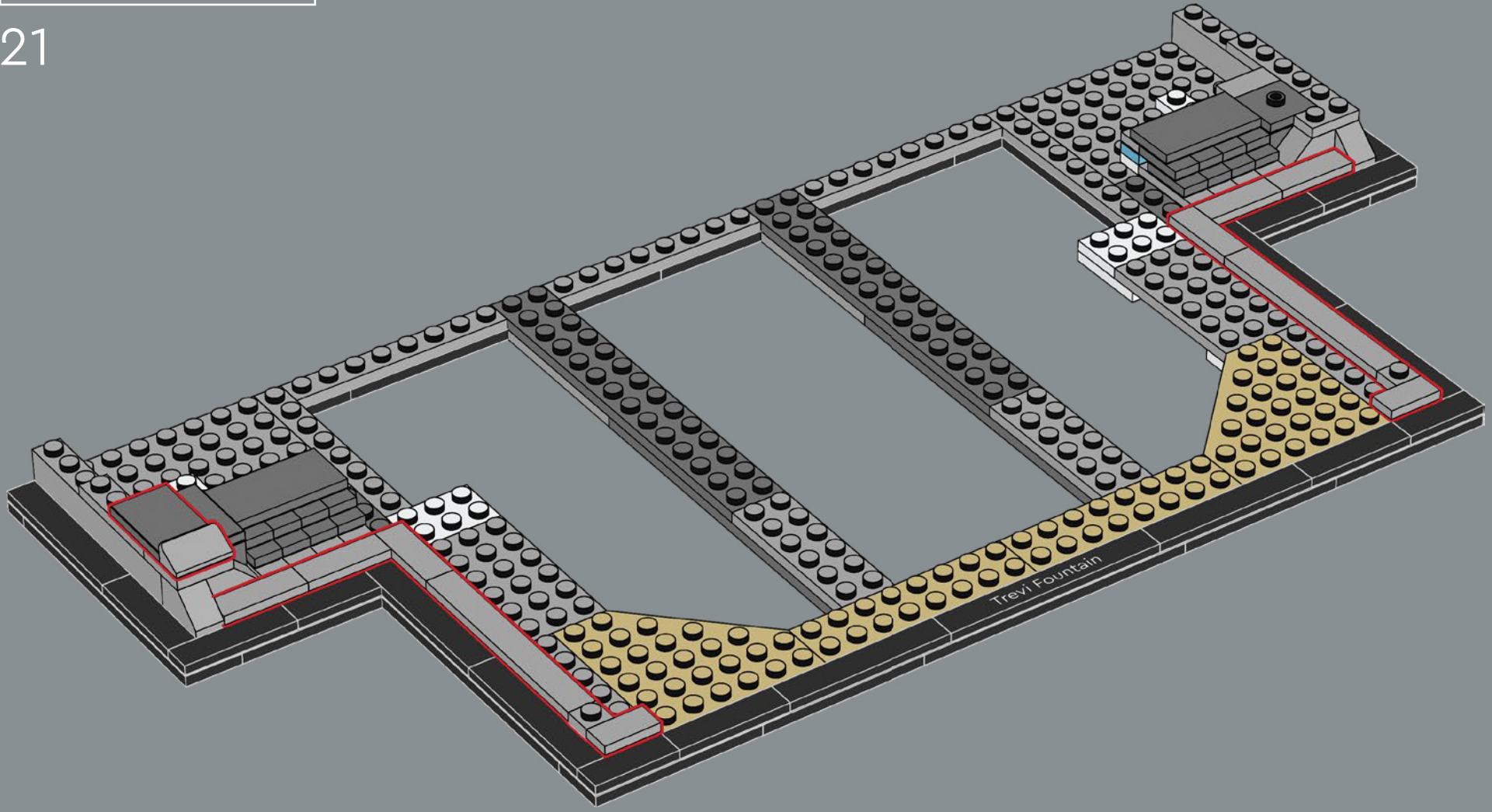

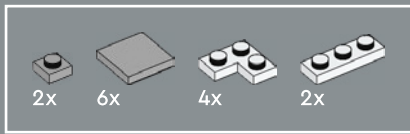

22

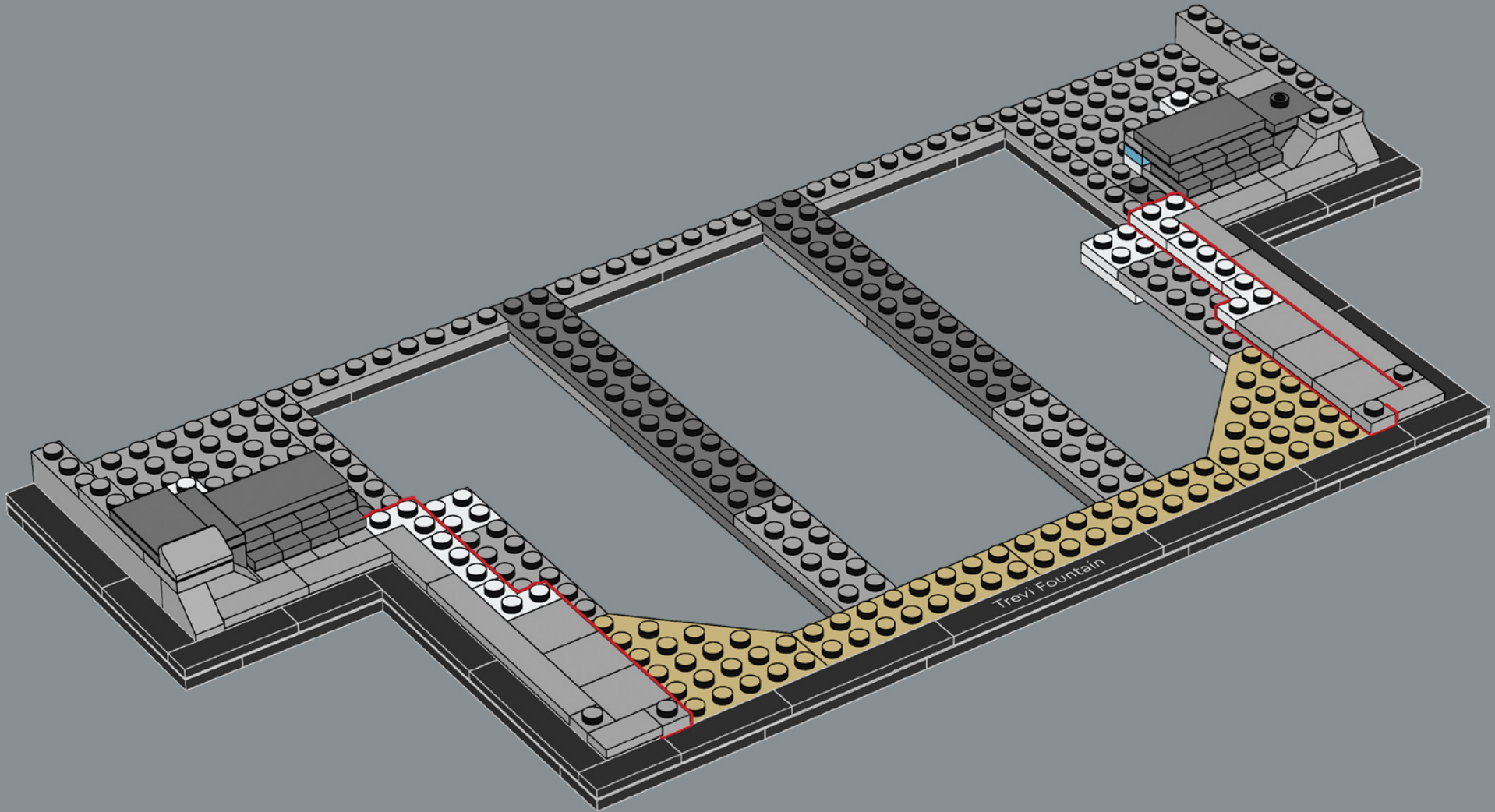

La place de Trevi accueille près de 10 millions de visiteurs chaque année, ce qui en fait l'une des destinations touristiques les plus populaires d'Italie.

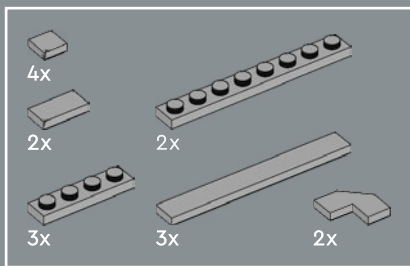

23

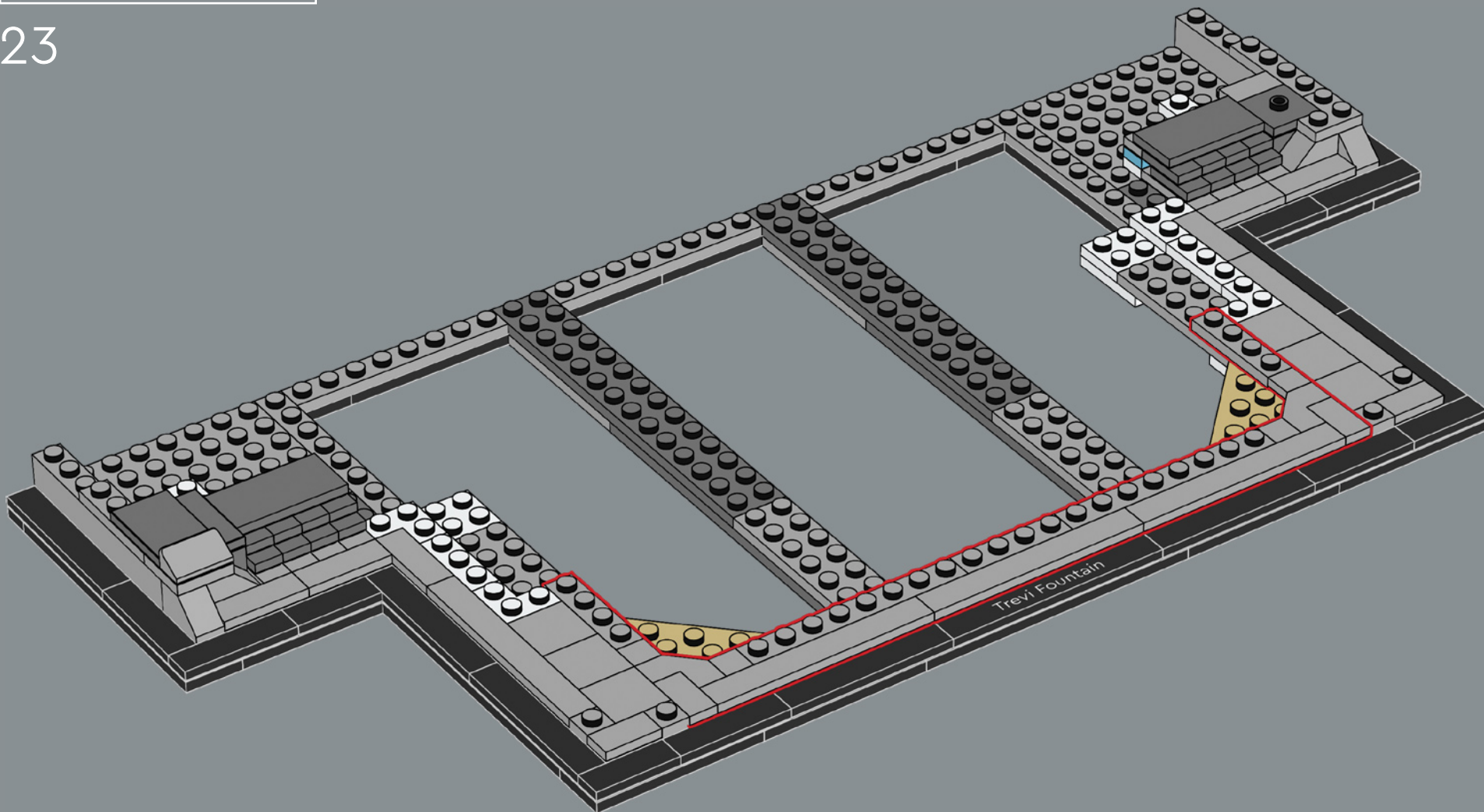

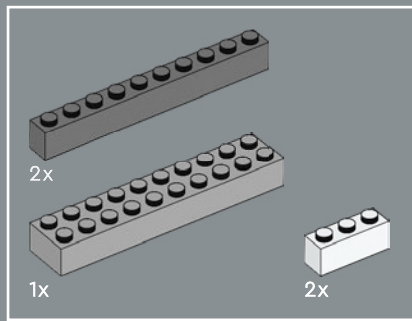

24

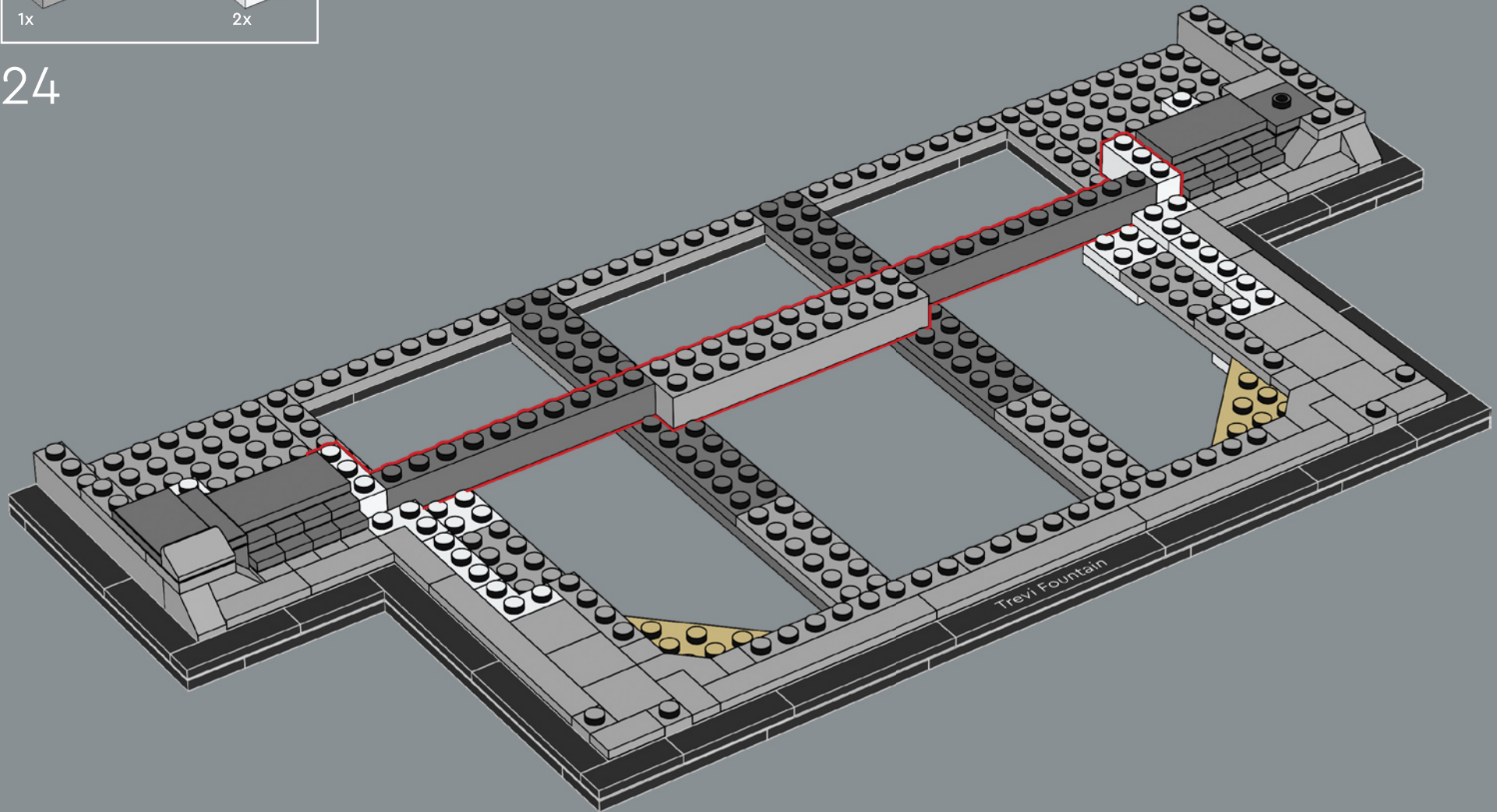

2x

25

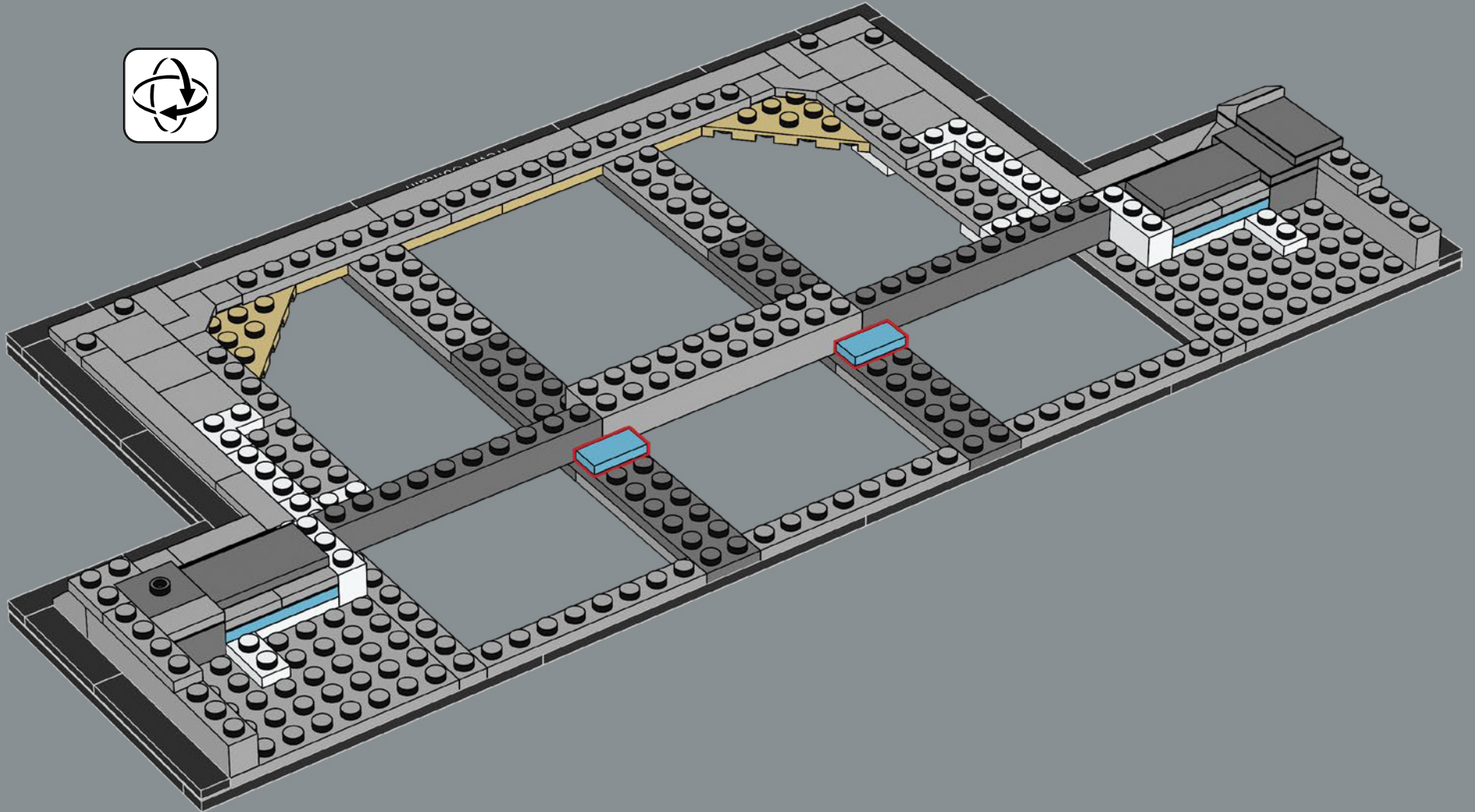

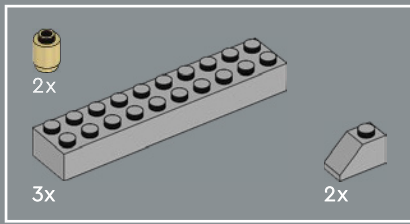

26

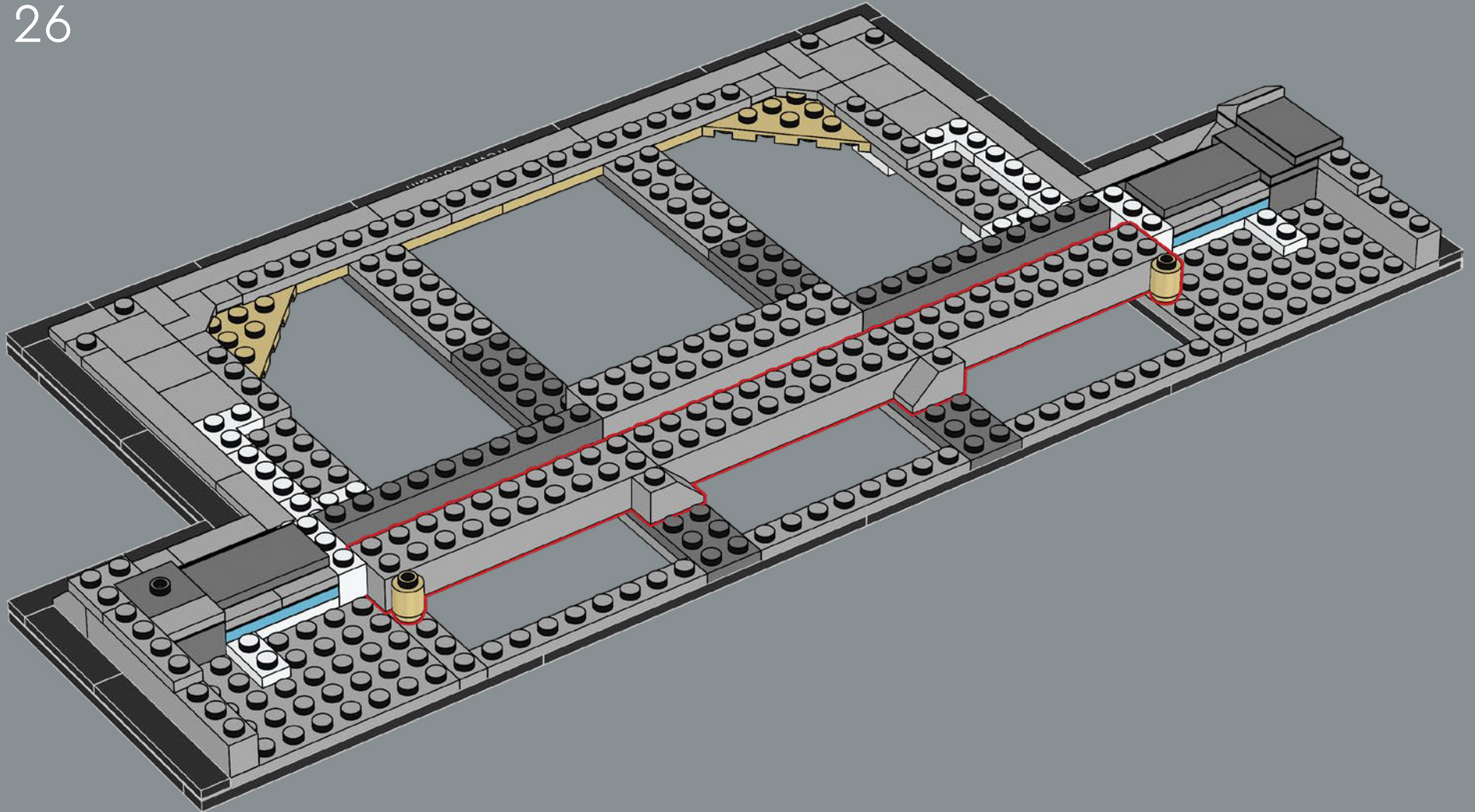

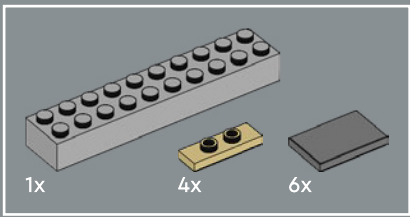

27

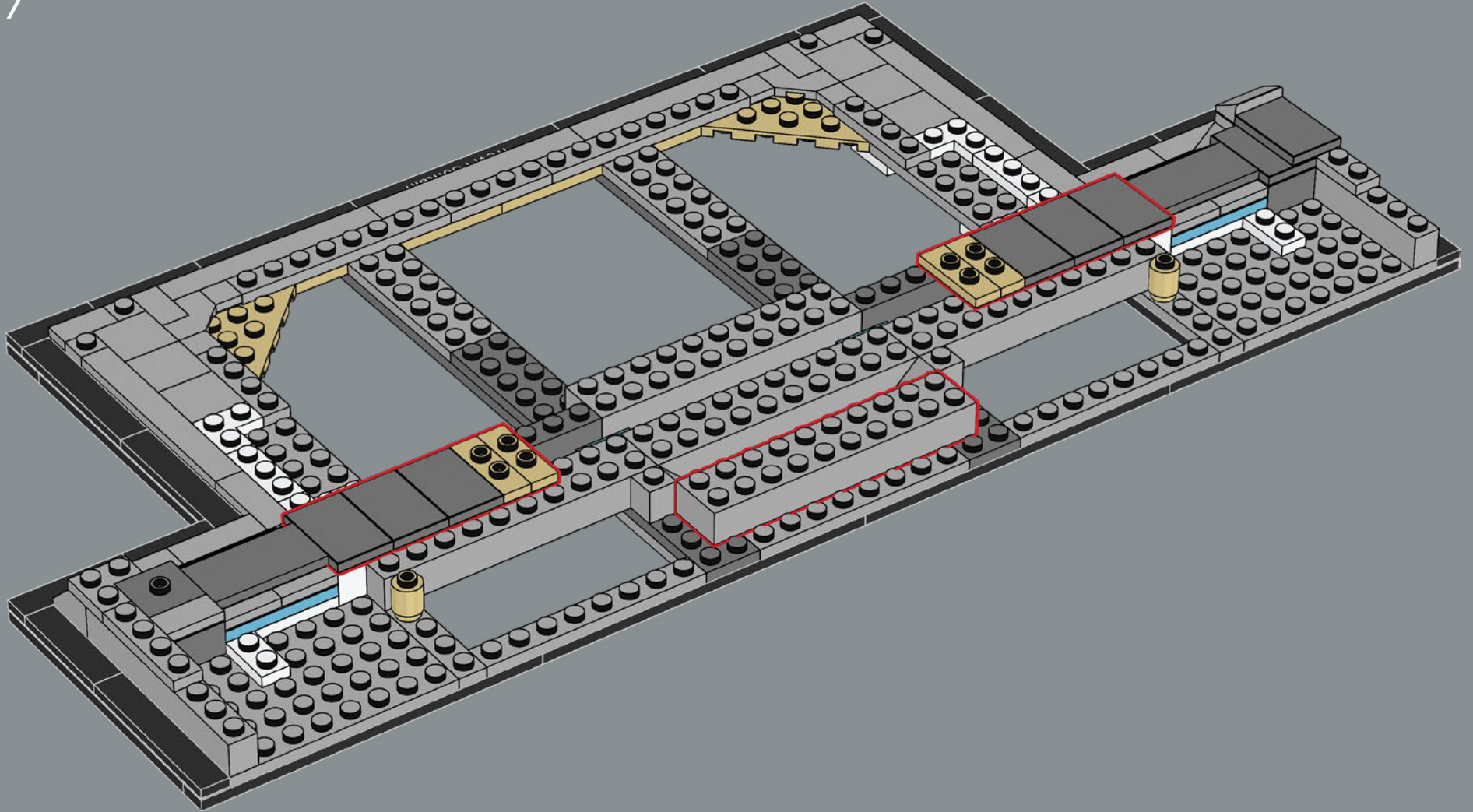

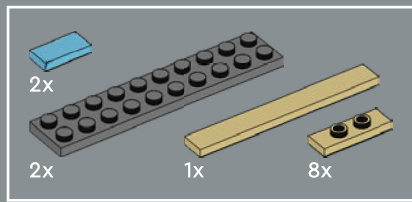

28

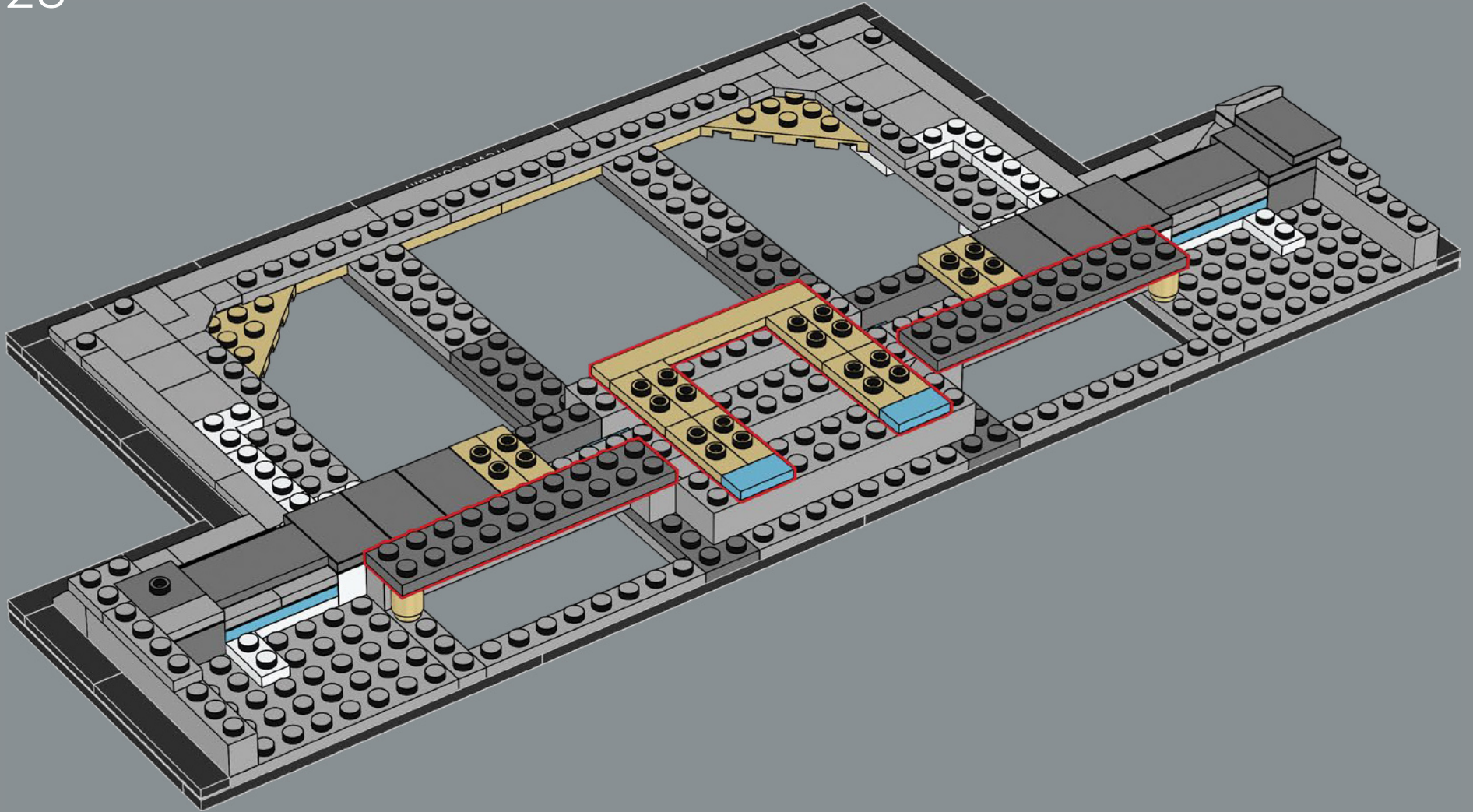

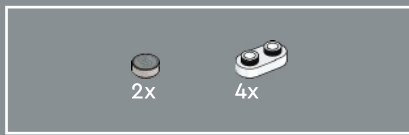

Selon une légende locale, si vous jetez une pièce dans la fontaine, vous reviendrez à Rome. Si vous jetez deux pièces, vous tomberez amoureux(se) d'une personne rencontrée près de la fontaine, en si vous en jetez trois, il se pourrait bien que vous restiez ensemble pour la vie !

29

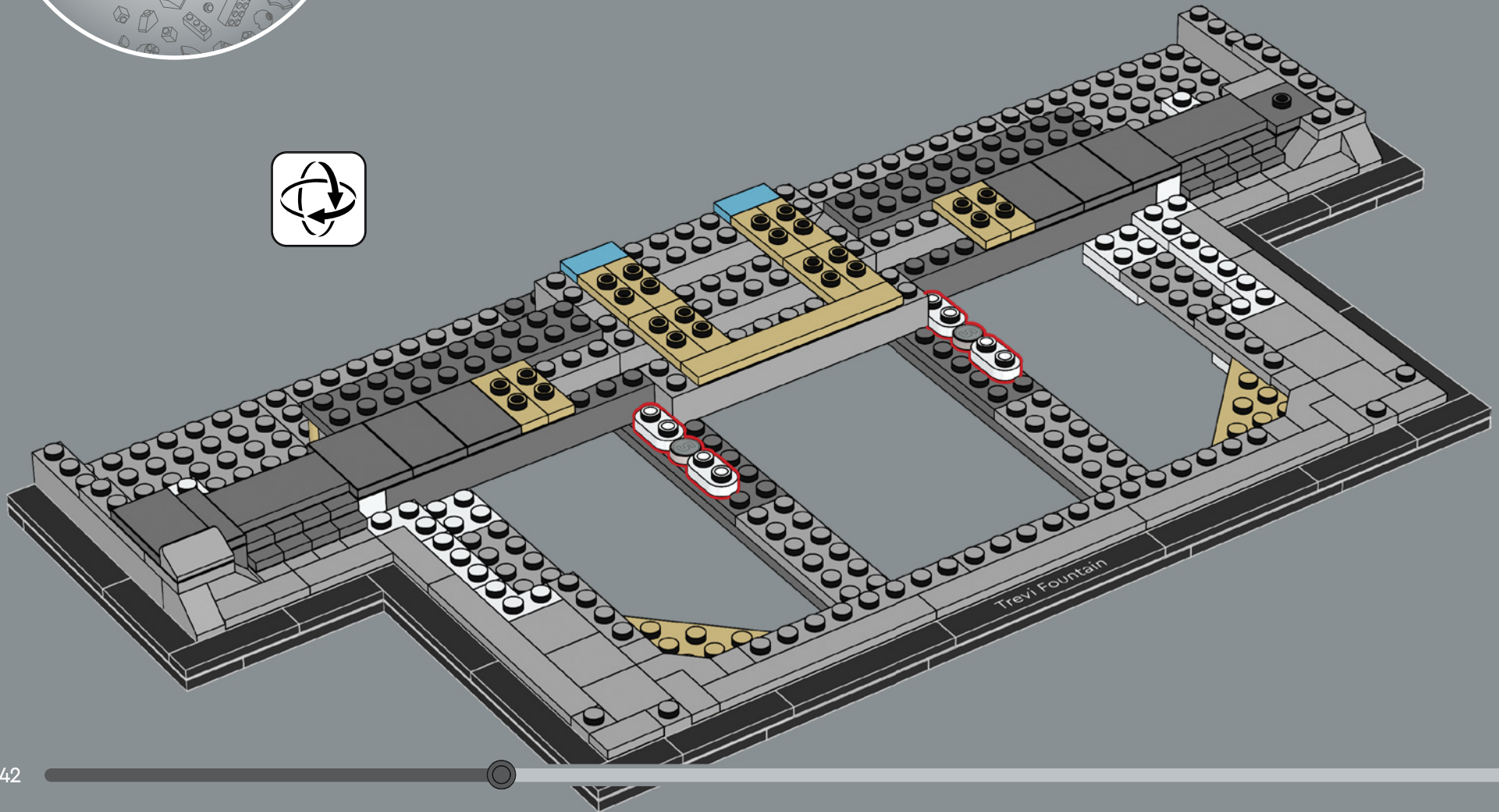

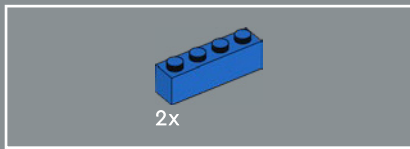

30

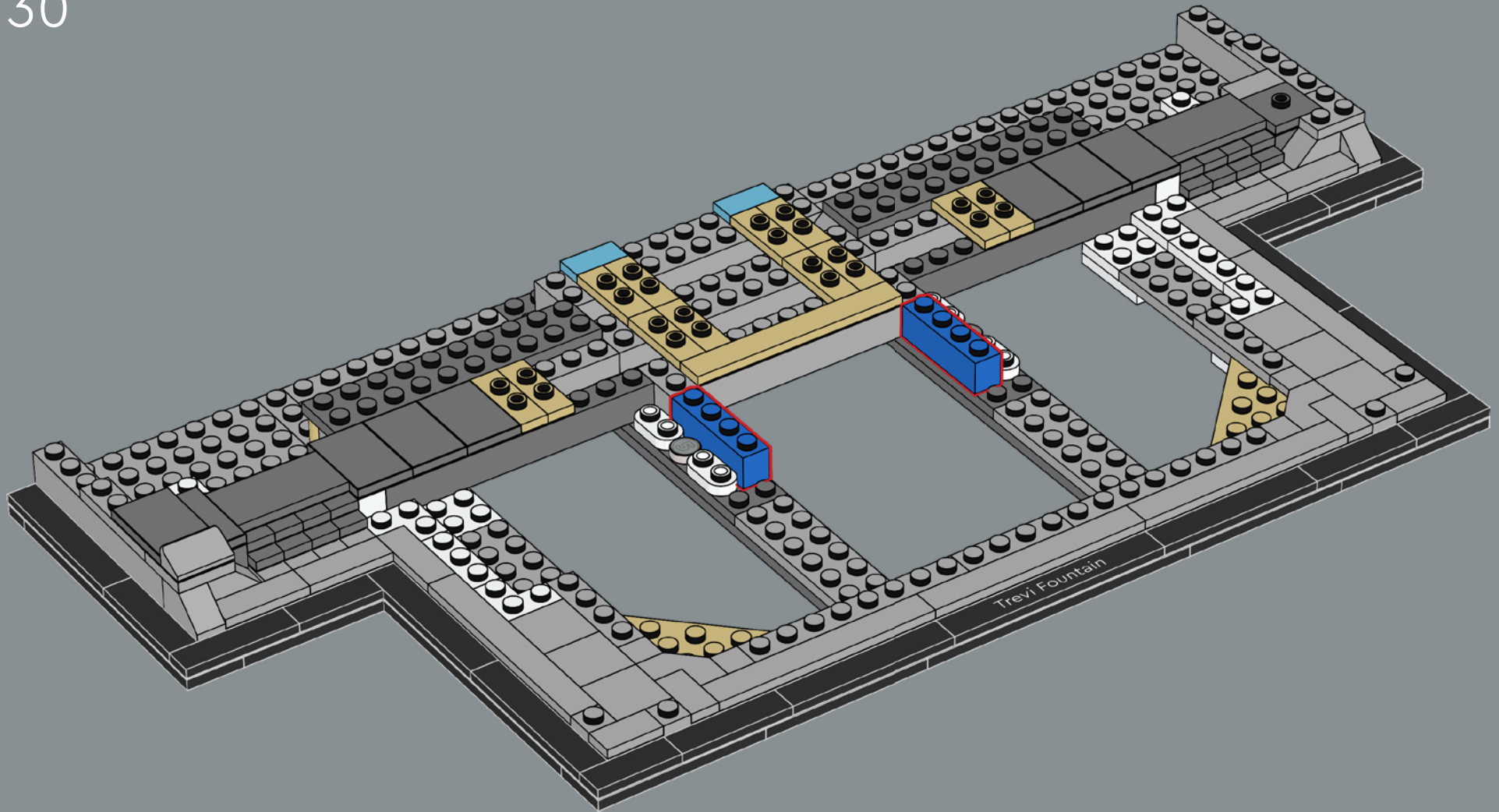

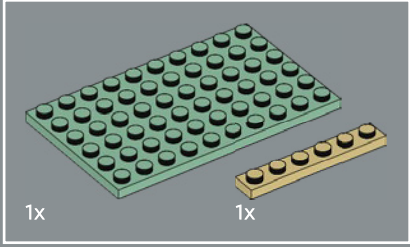
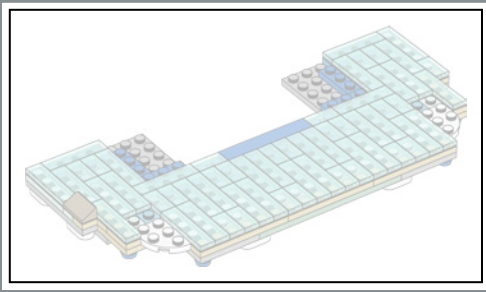

31

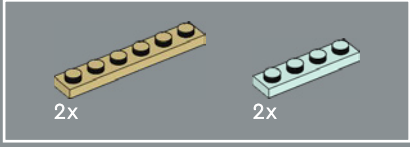
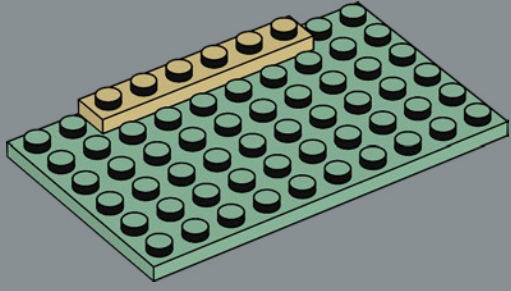

32

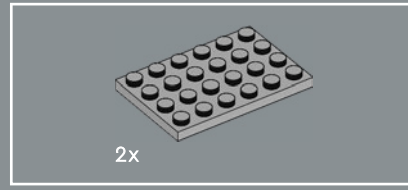
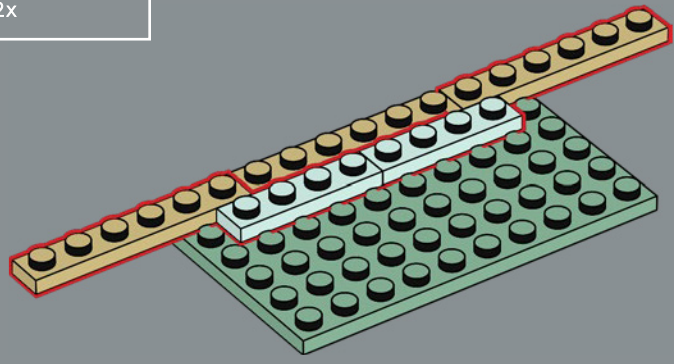

33

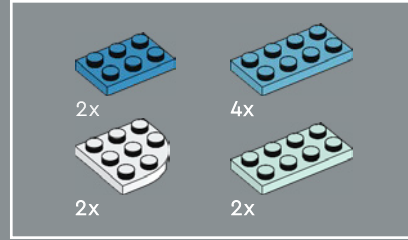
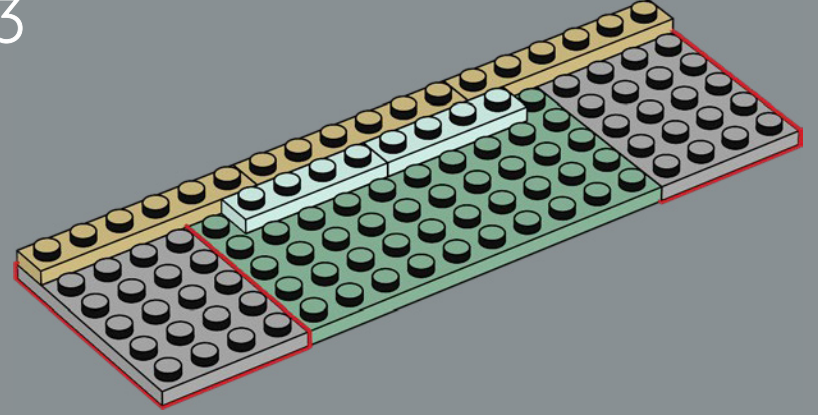

34

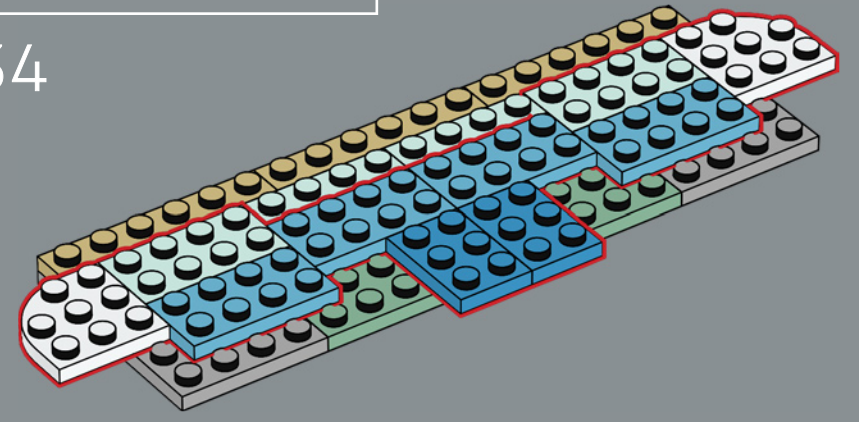

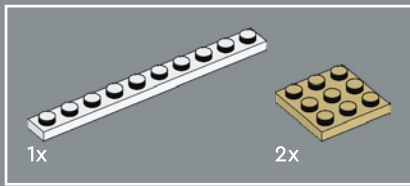

35

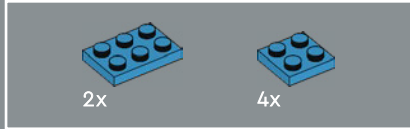
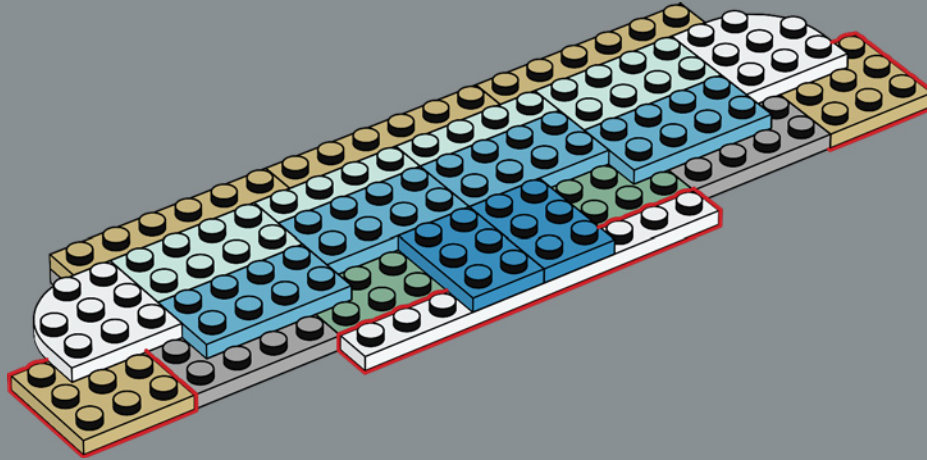

36

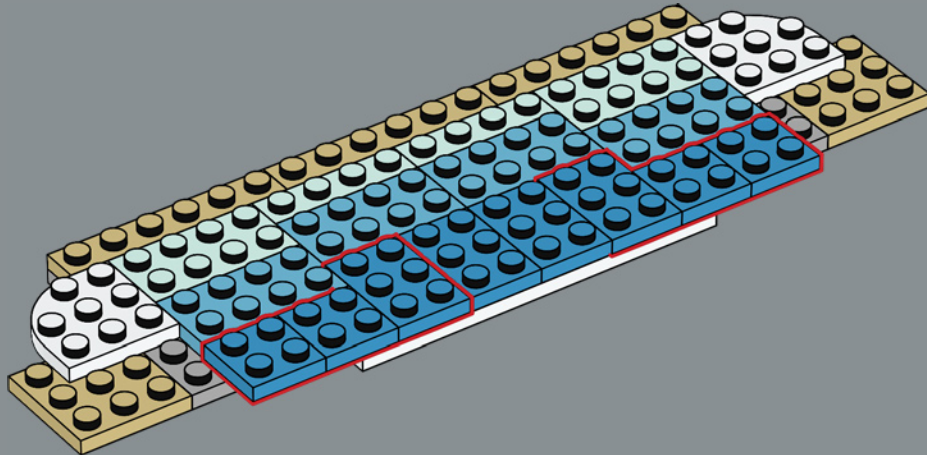

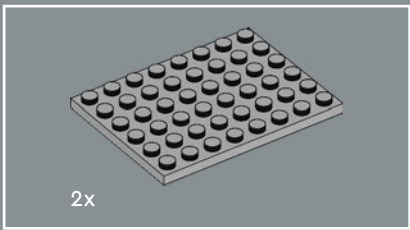

37

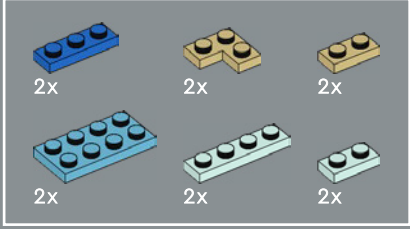
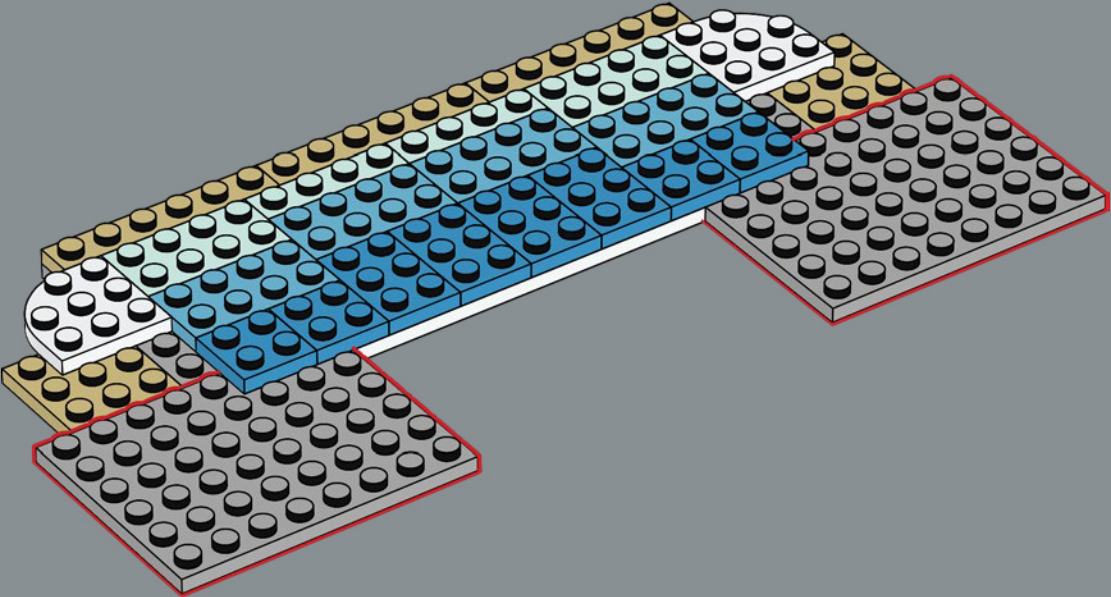

38

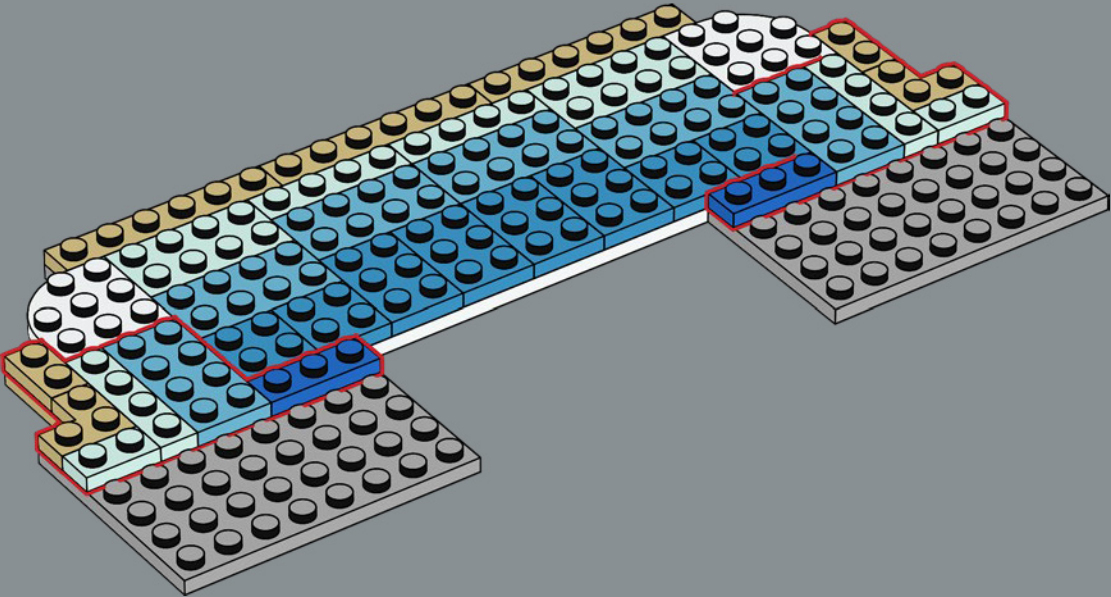

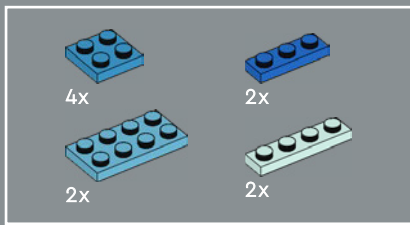

39

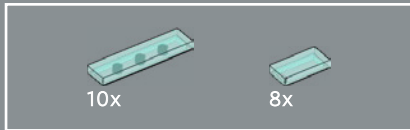
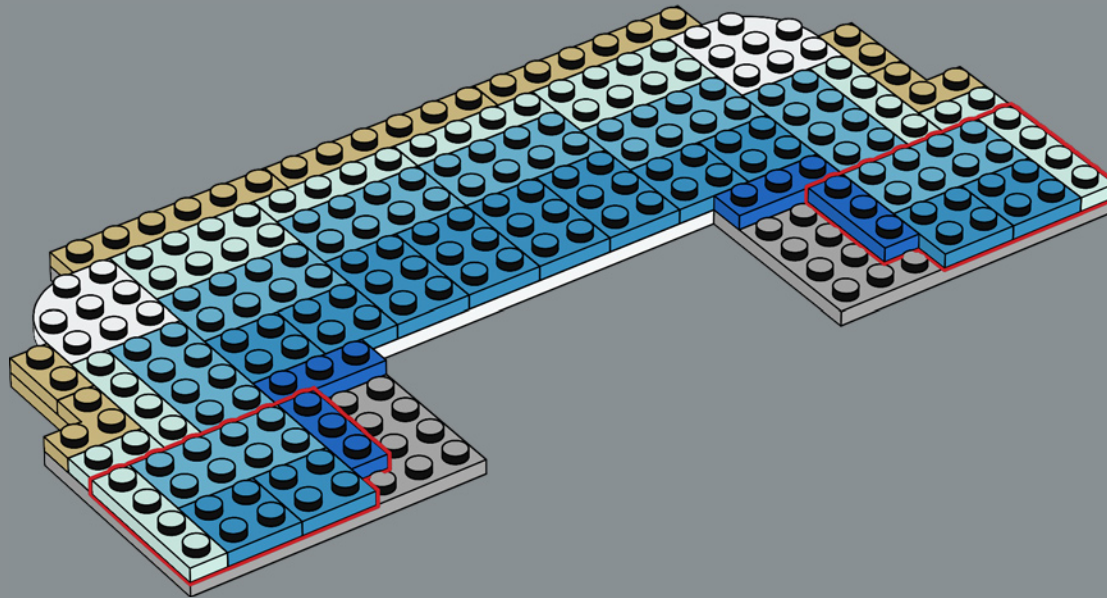

40

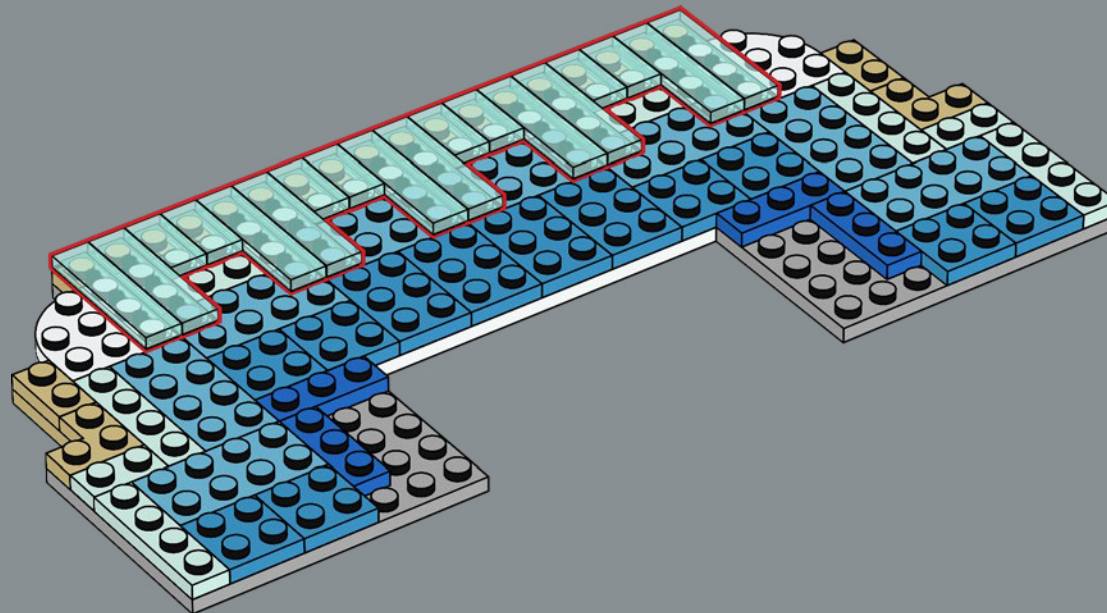

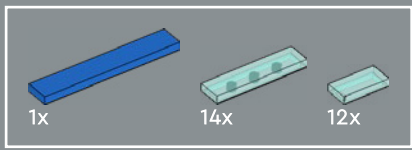

41

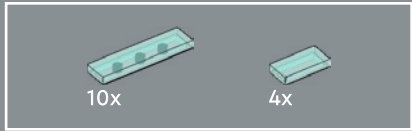
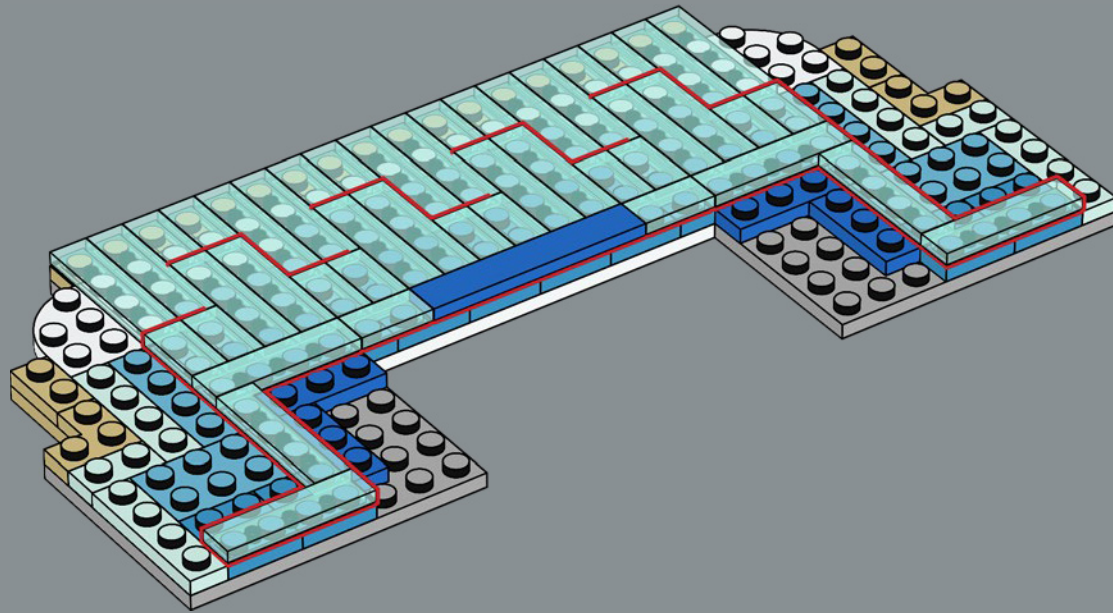

42

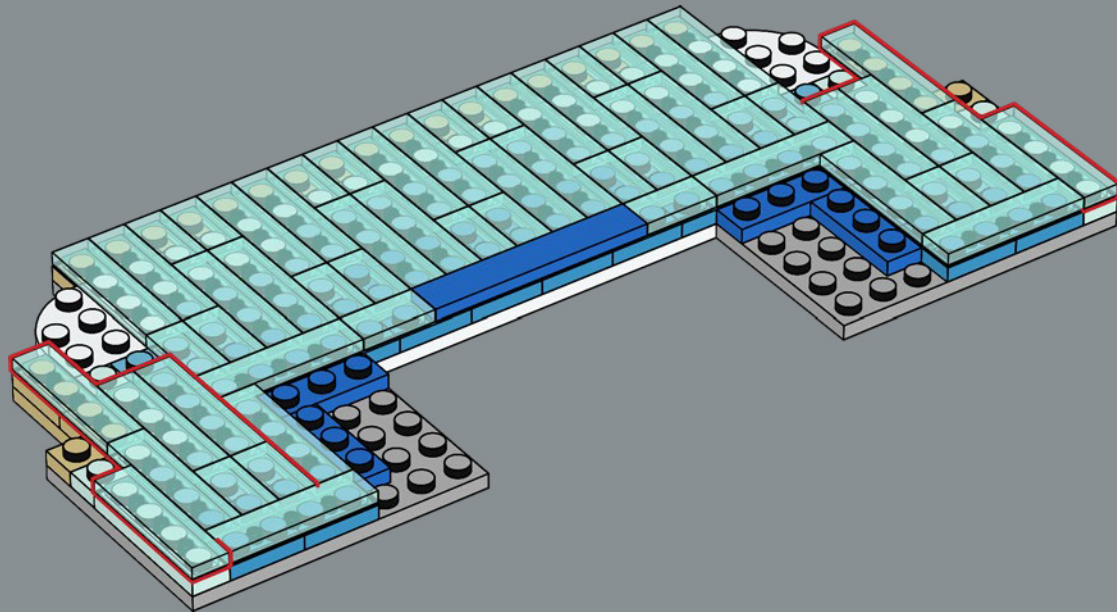

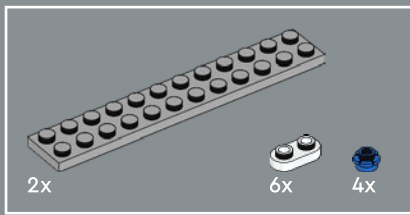

43

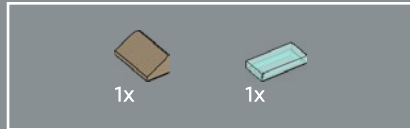
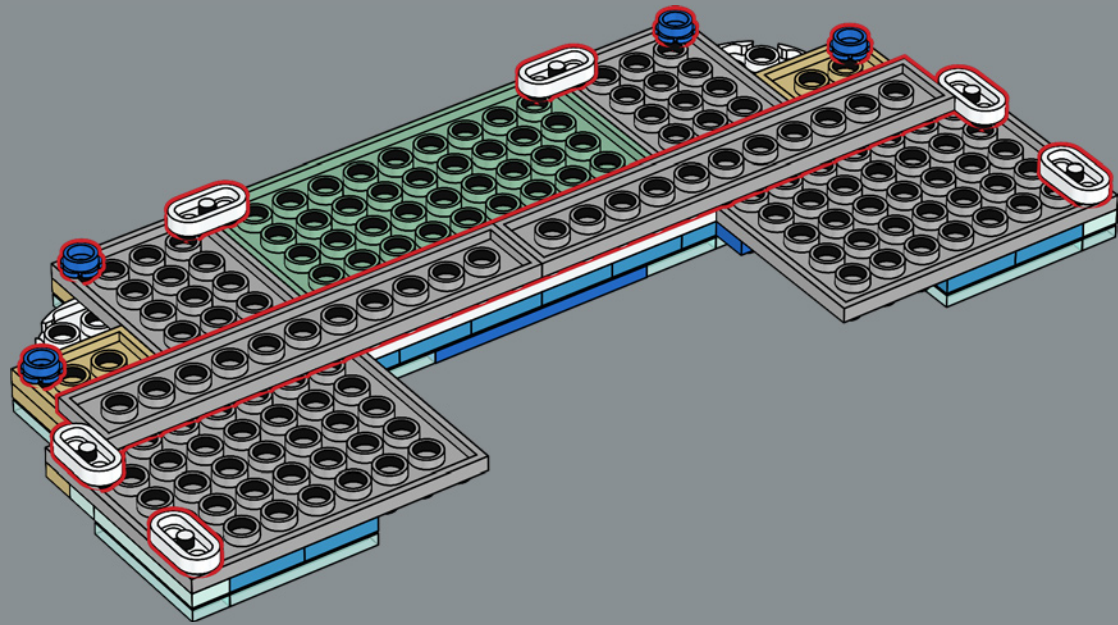

44

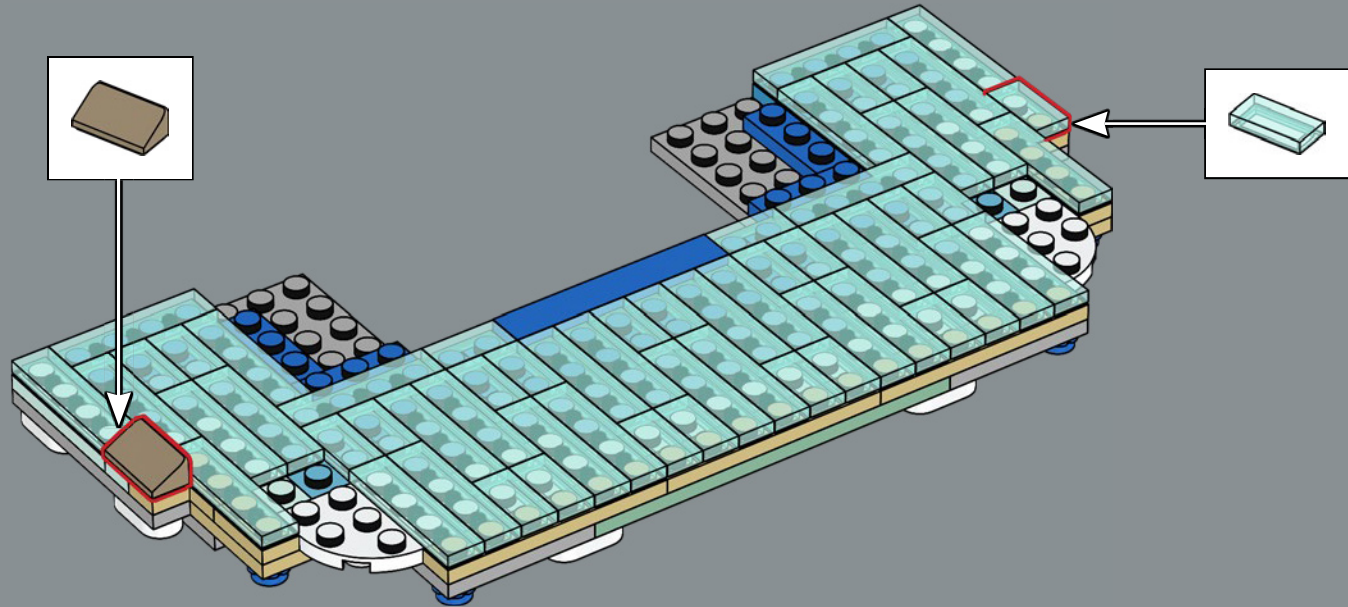

Chaque jour, près de 3 000 € sont jetés dans la fontaine. Les pièces sont ramassées à la fin de la journée, et une grande partie des dons est redistribuée à des œuvres de charité.

45

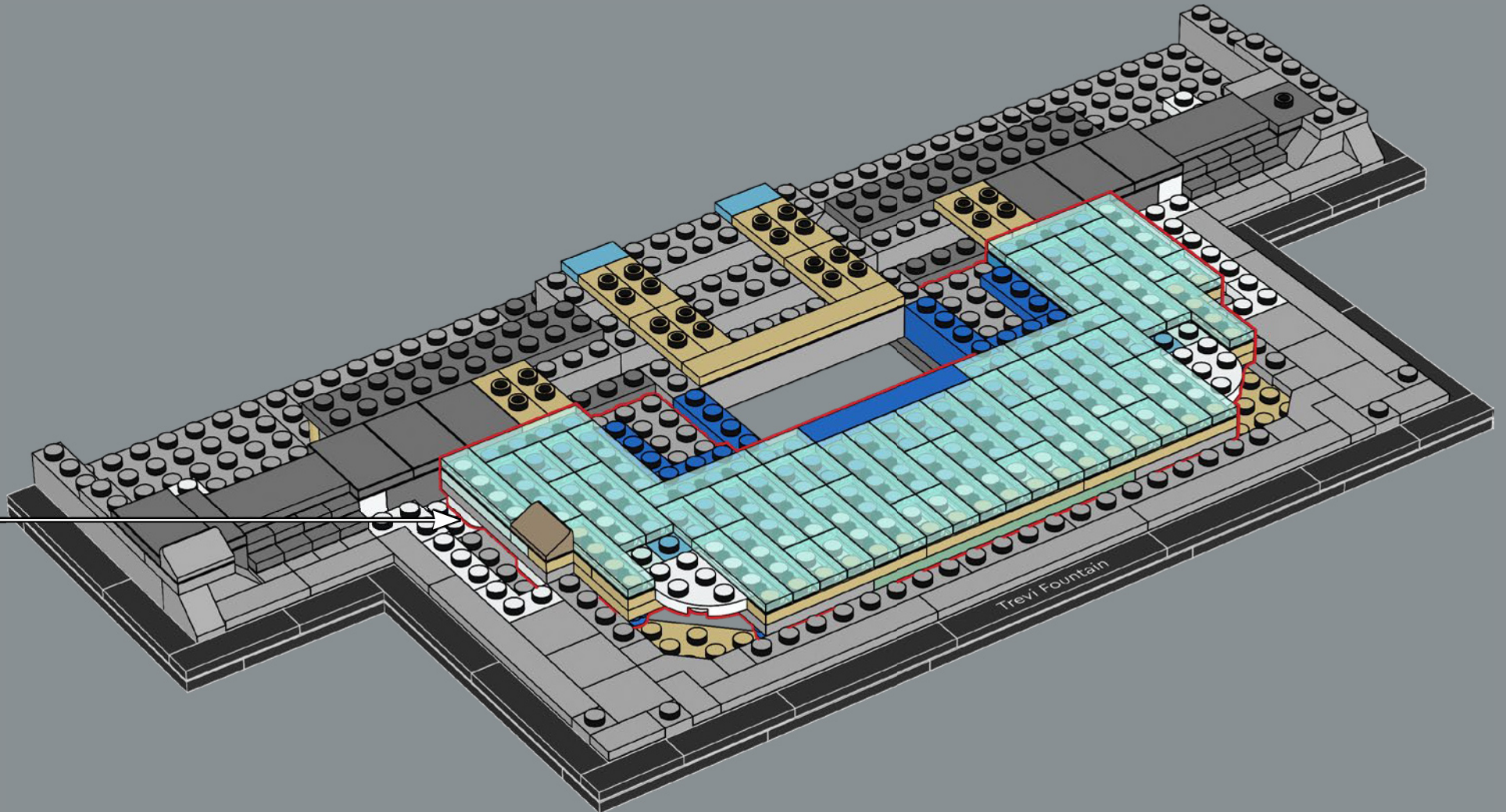



46

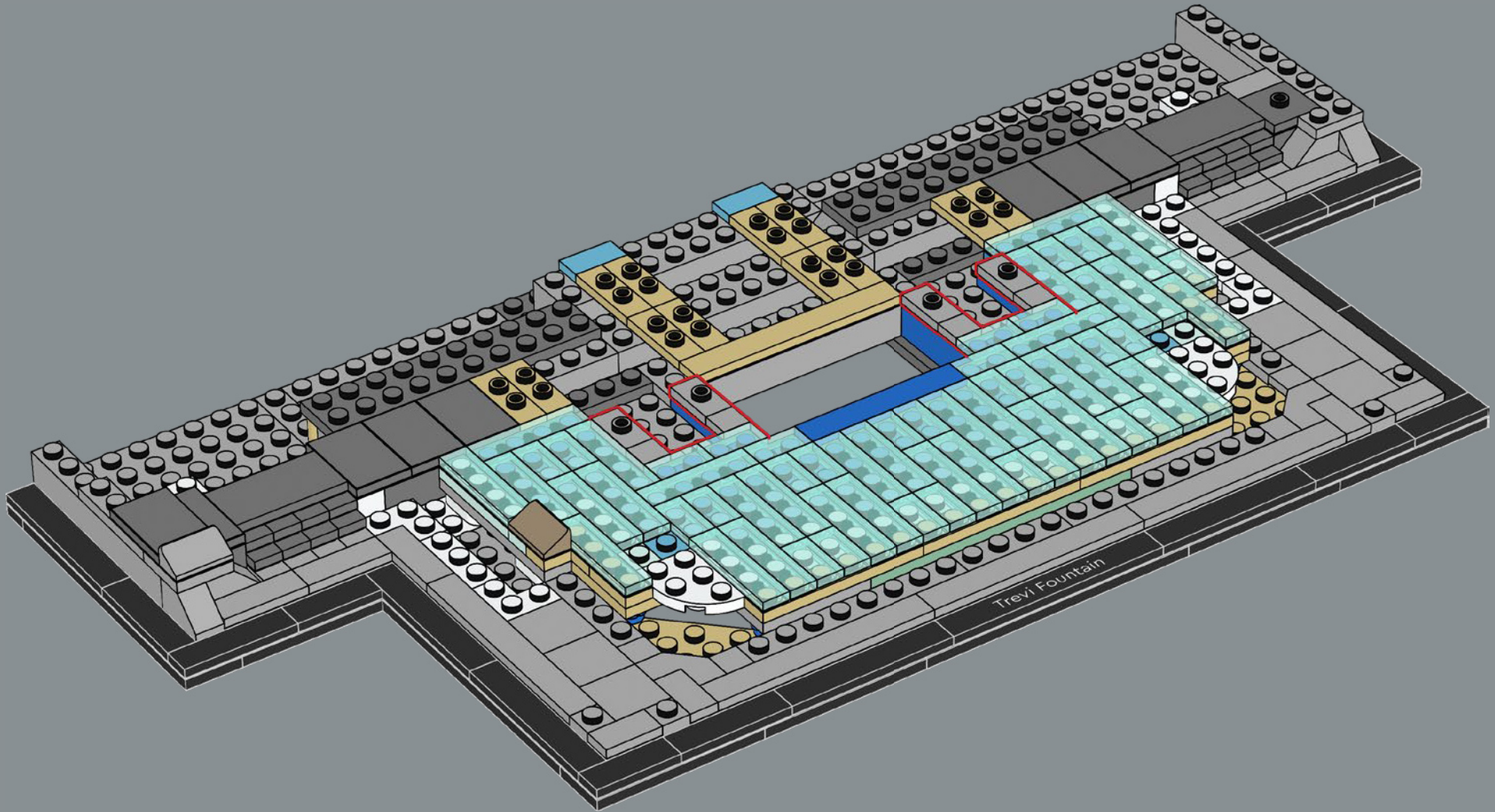

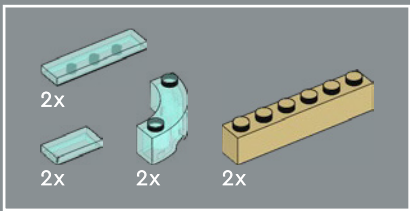

47

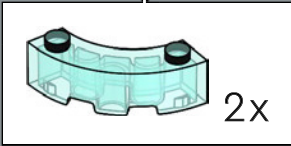
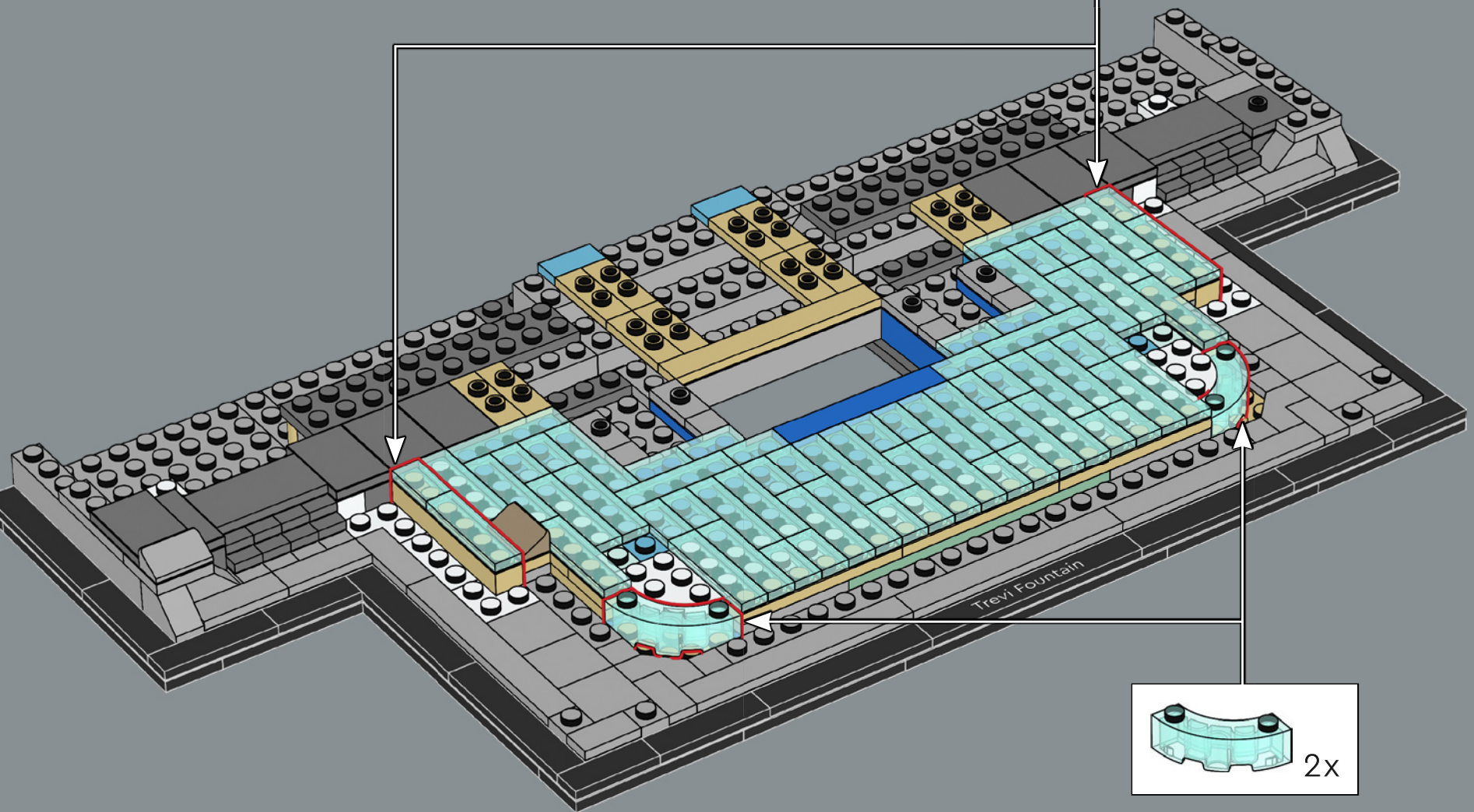
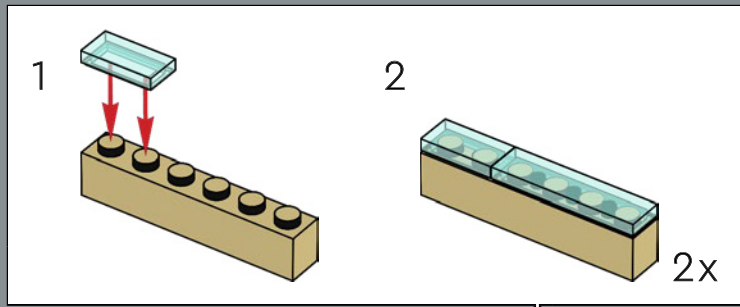

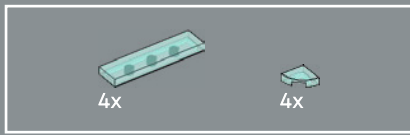

48

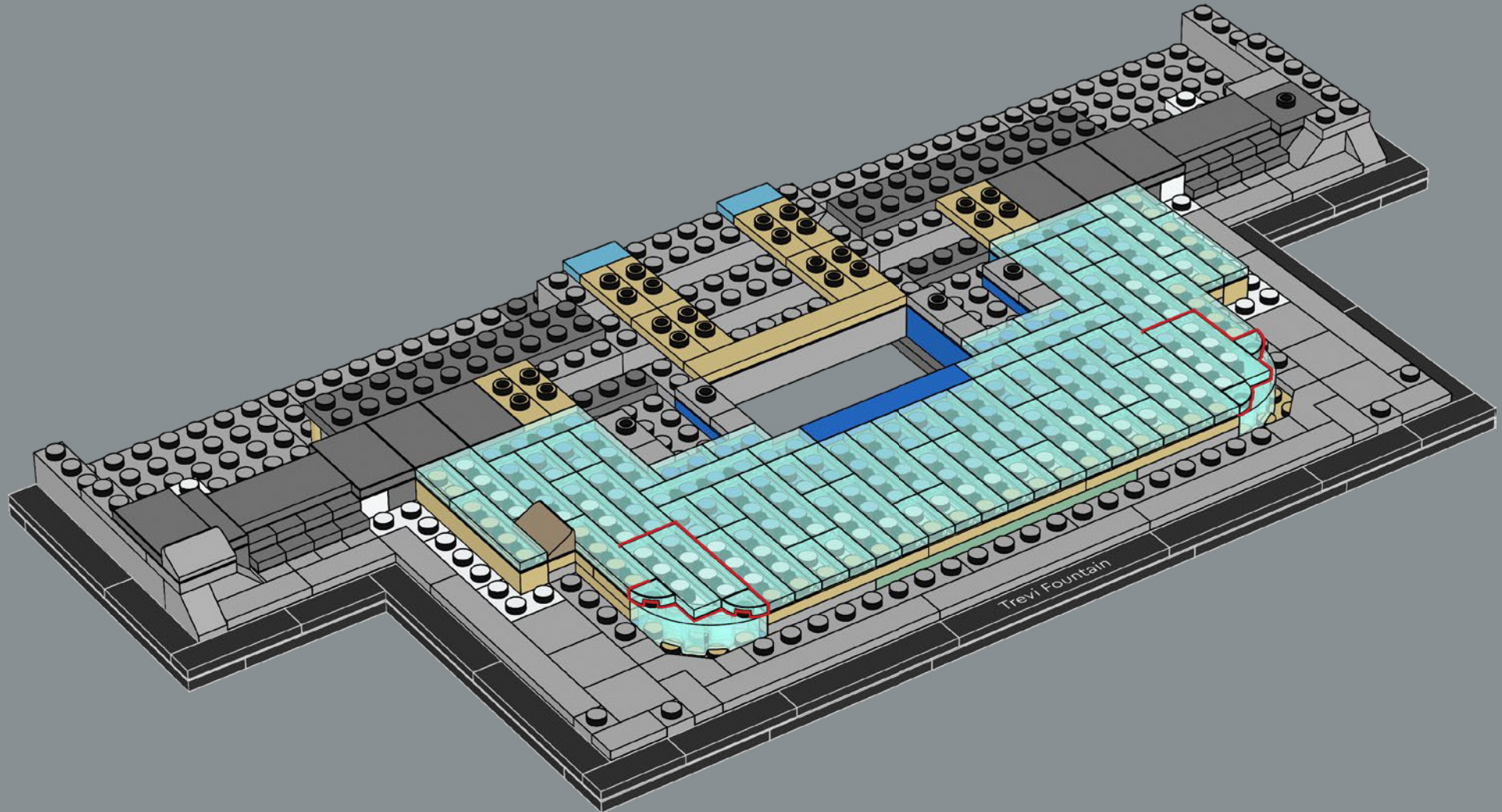

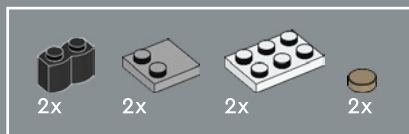

49

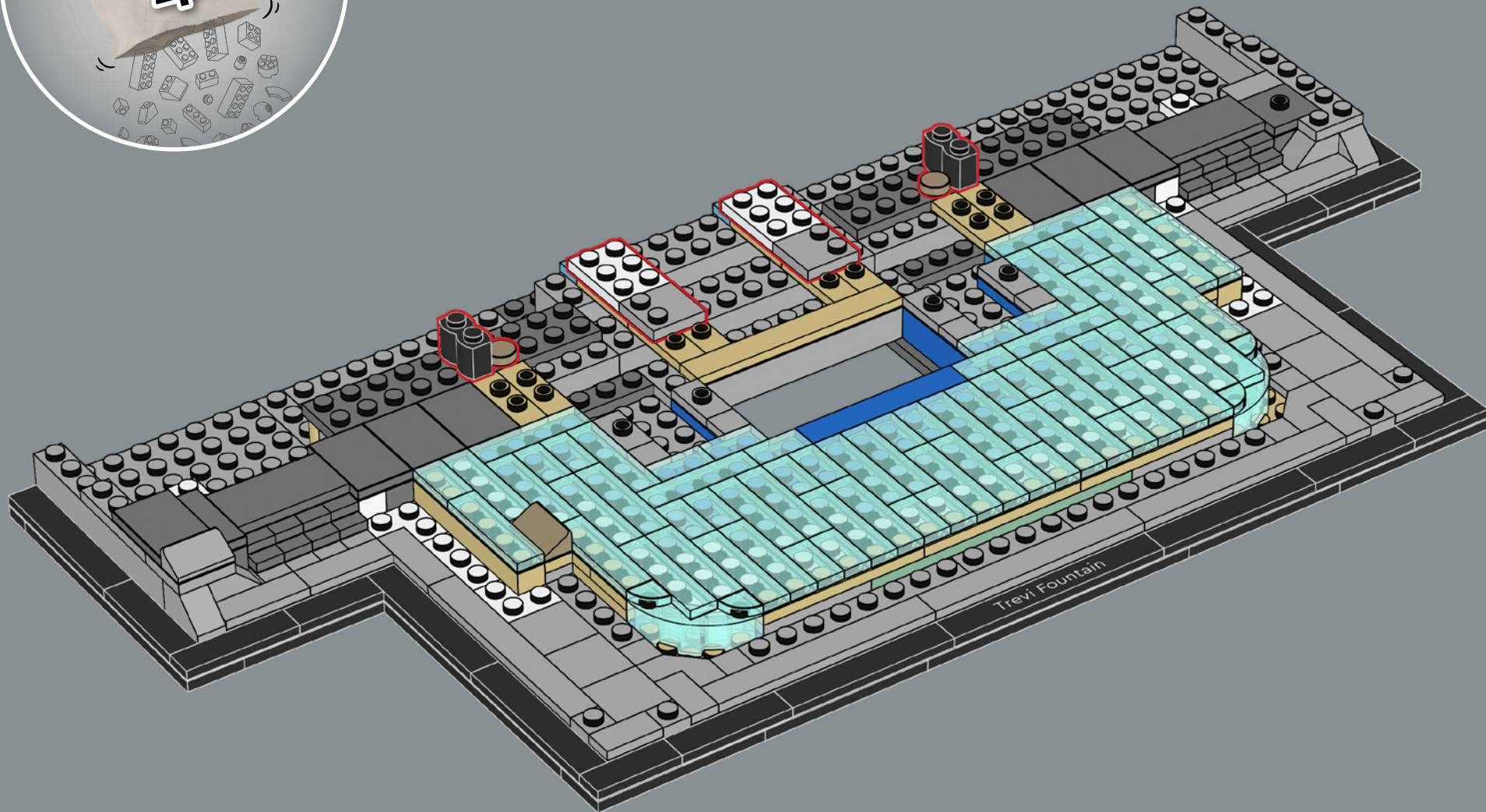

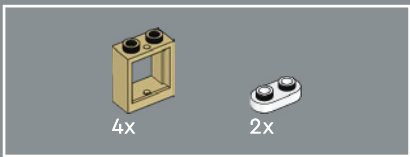

50

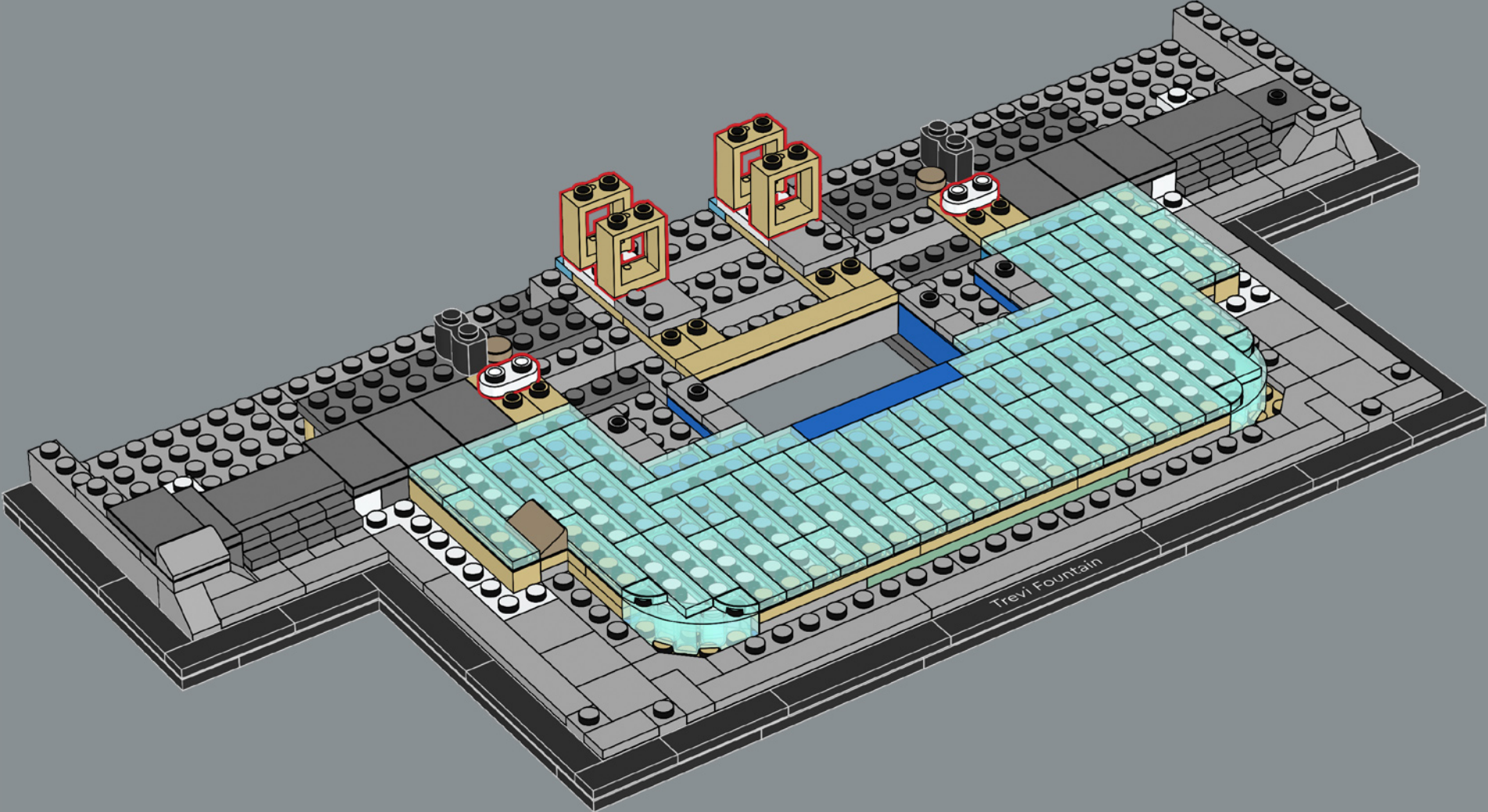

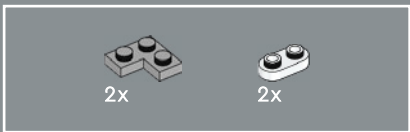

51

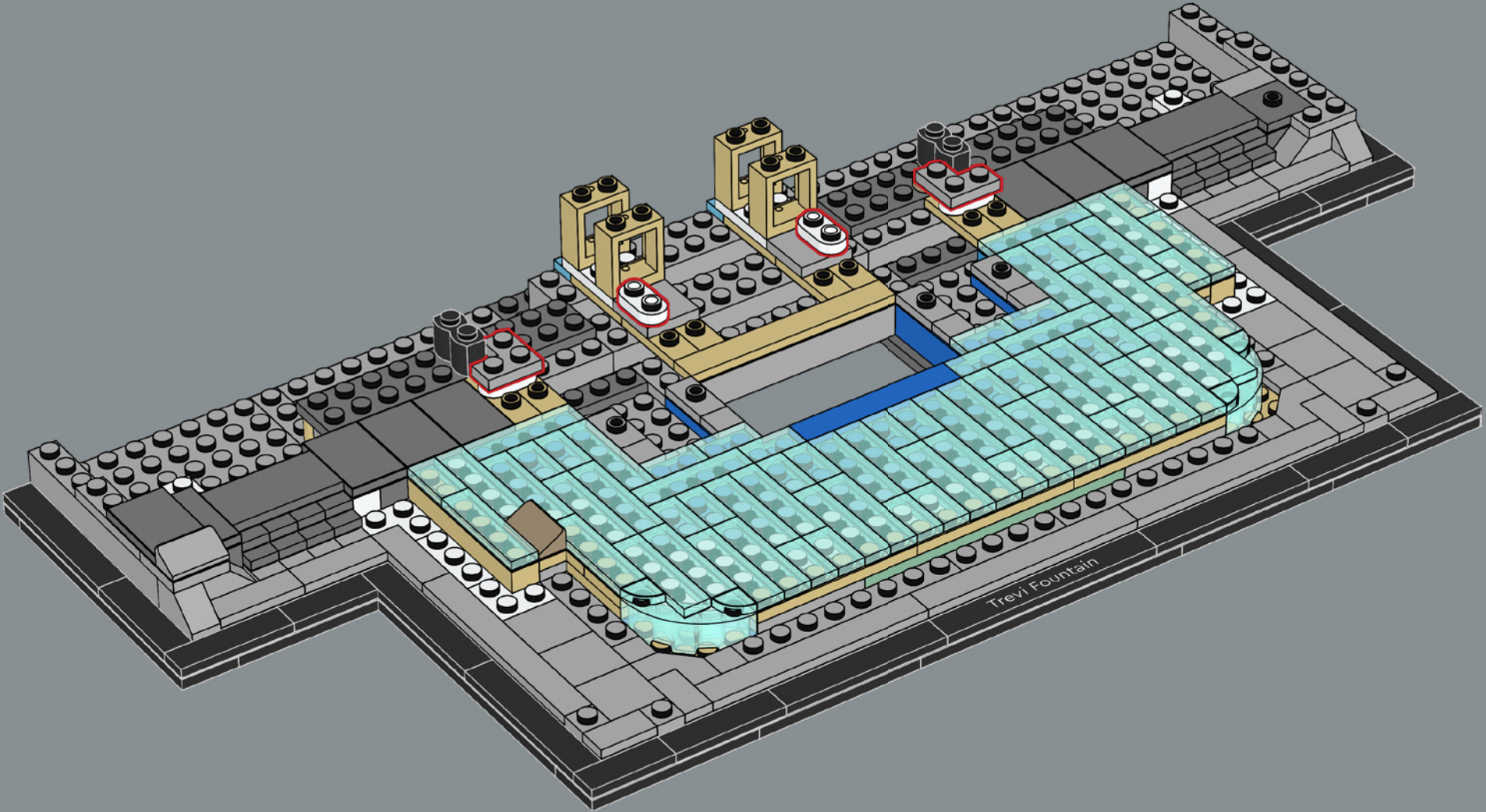

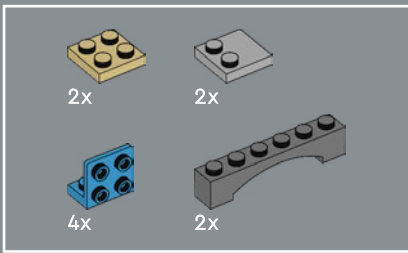

52

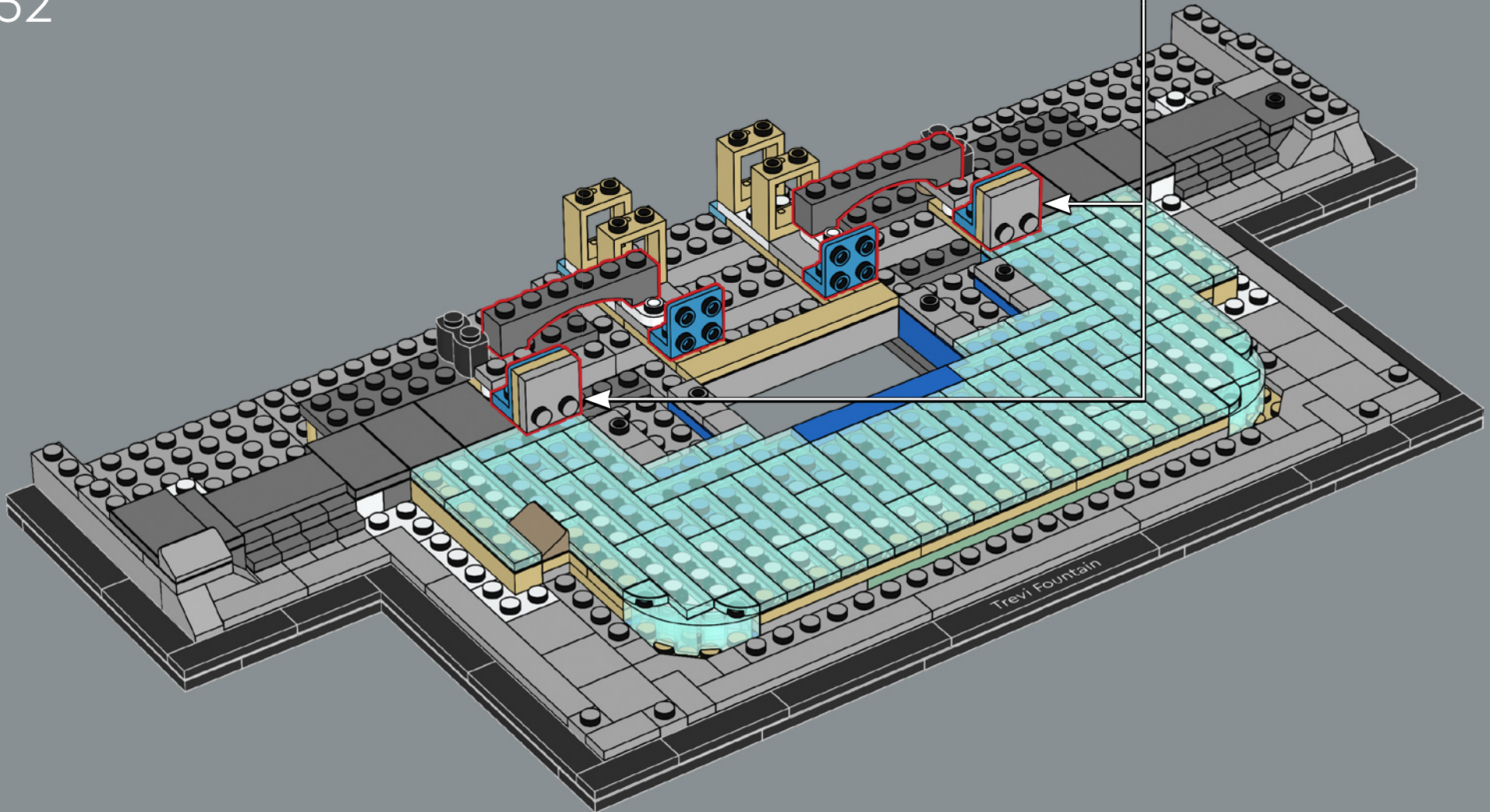
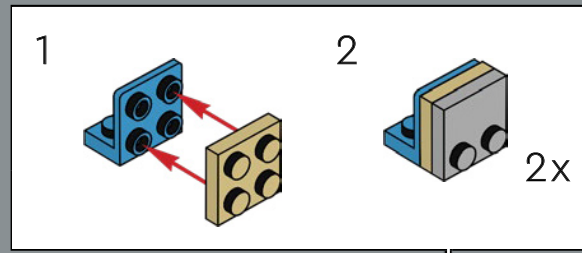

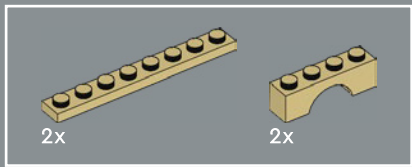

53

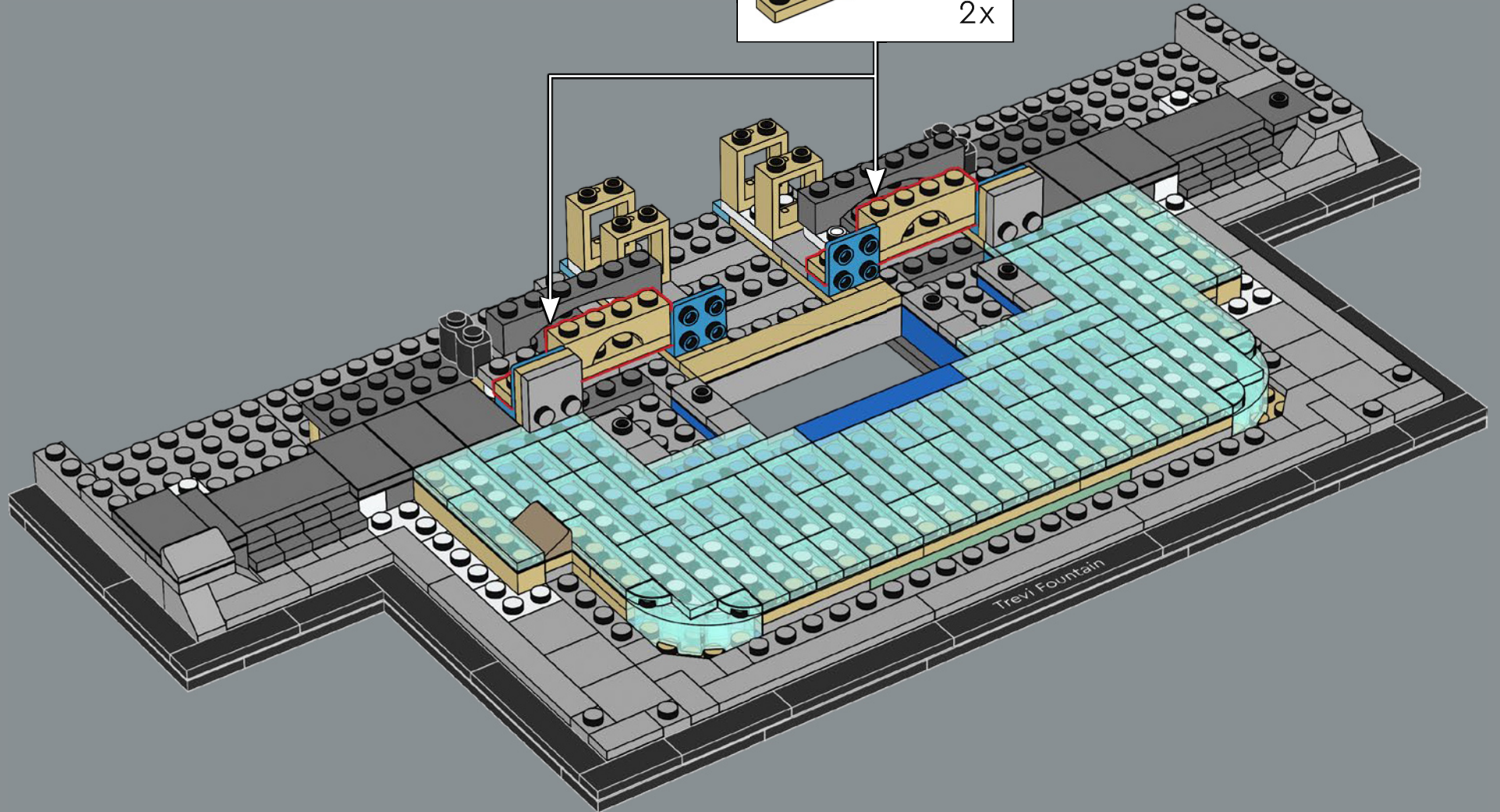
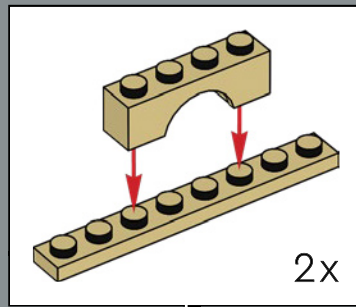

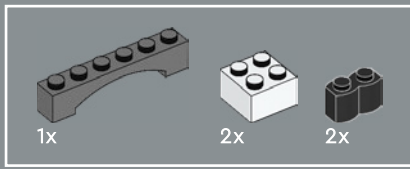

54

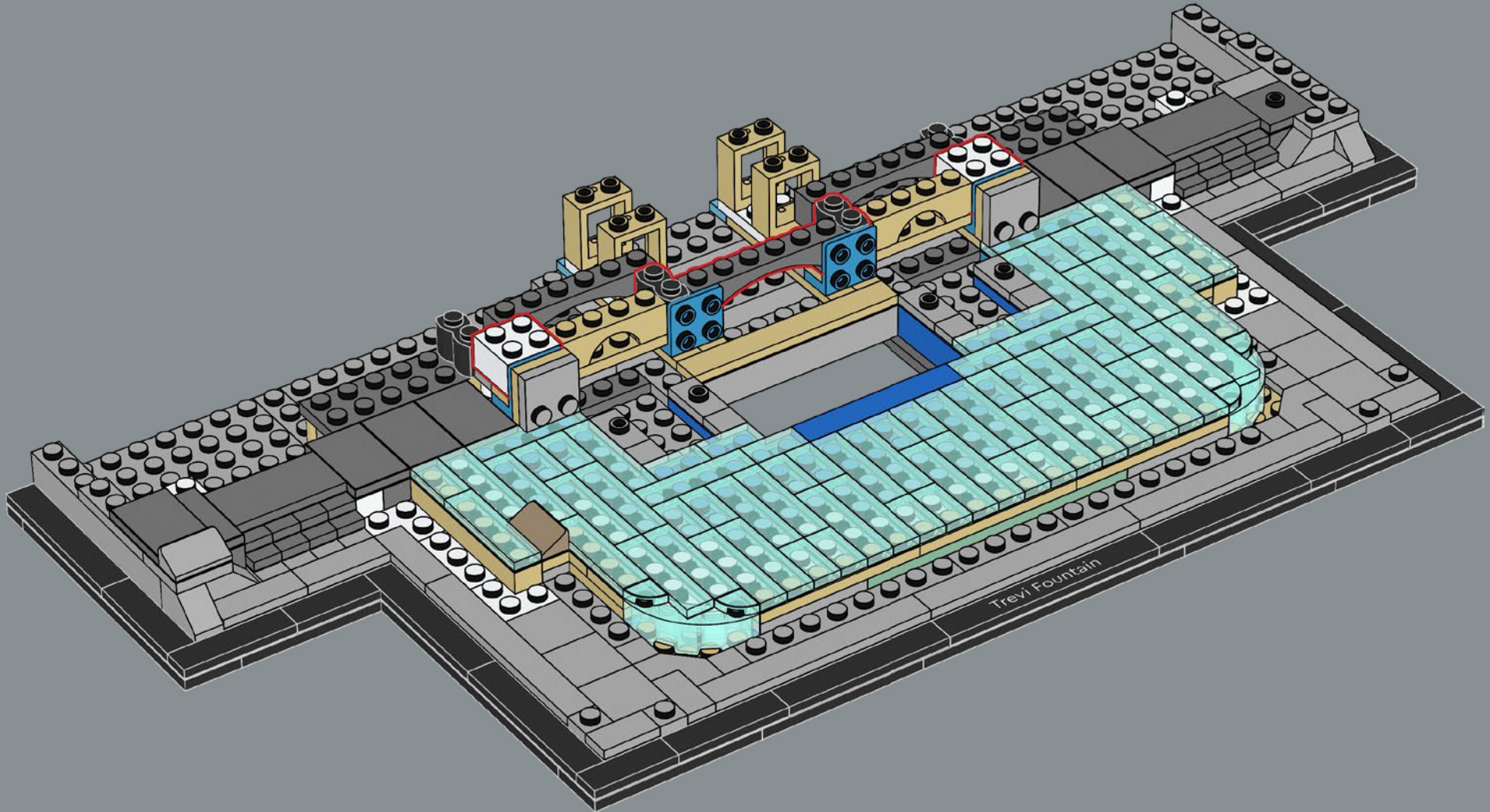

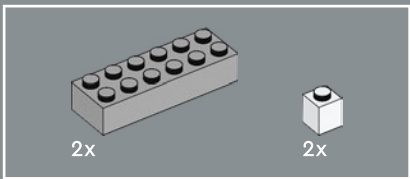

55

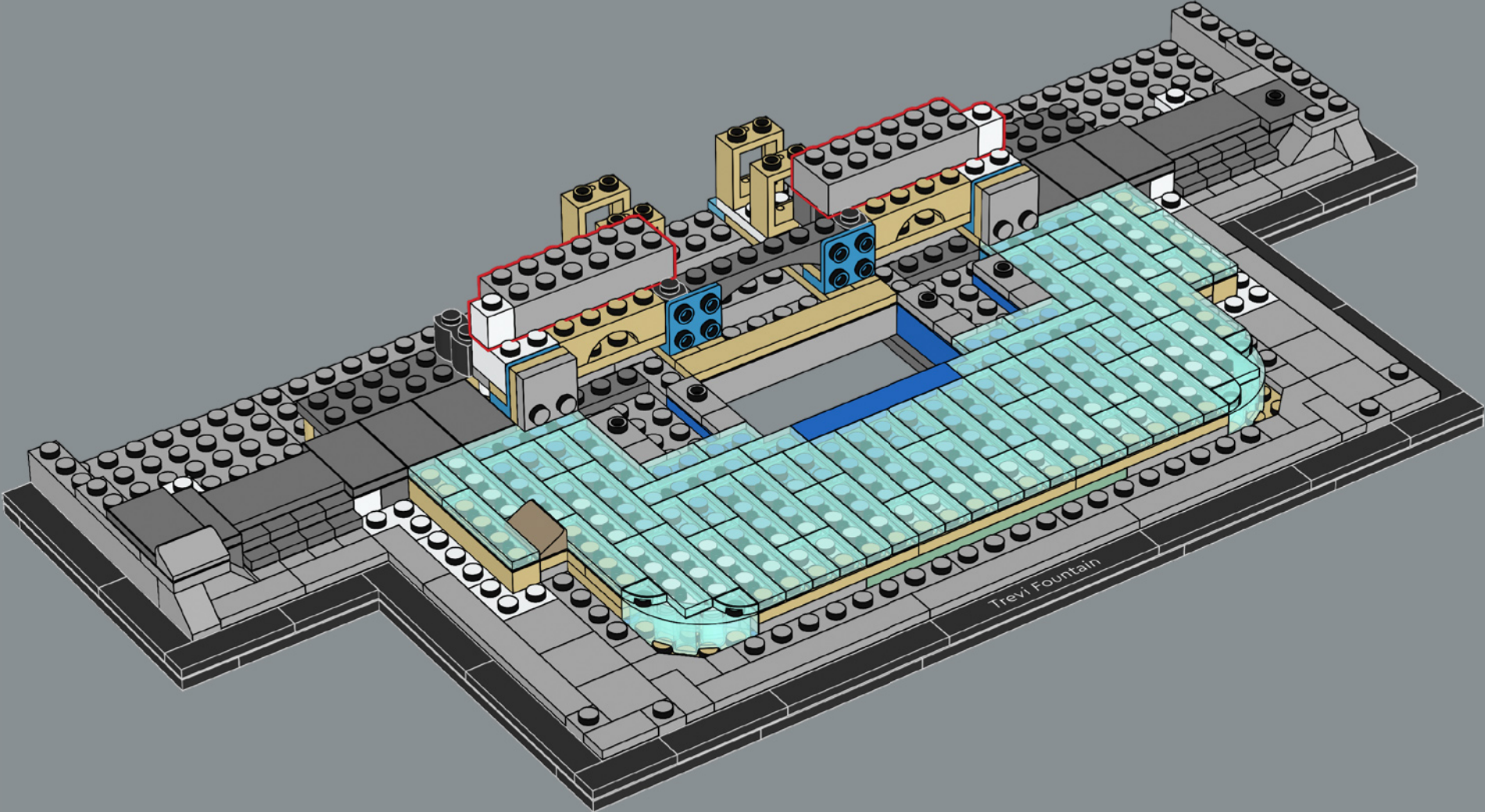

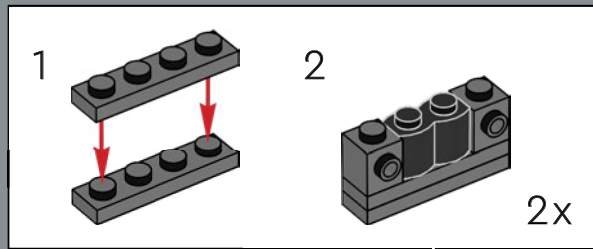
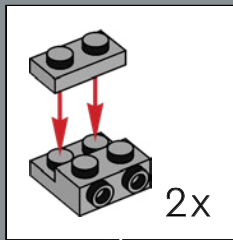
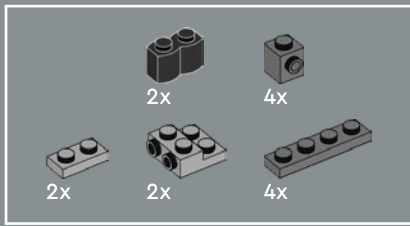

56

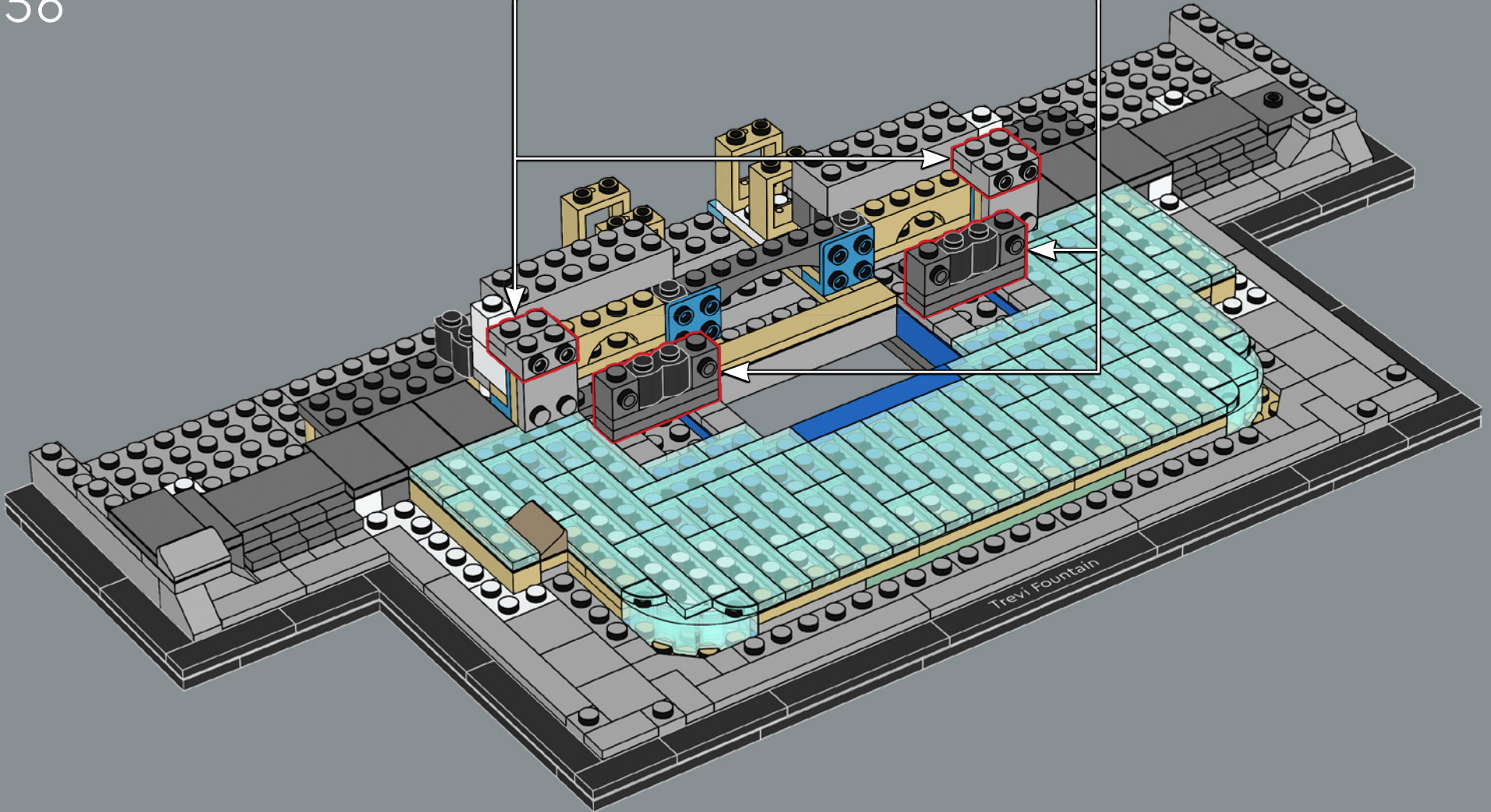

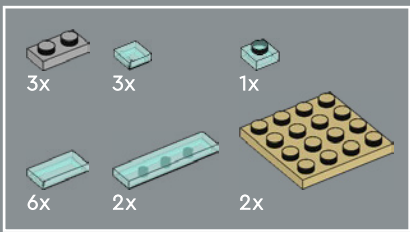

57

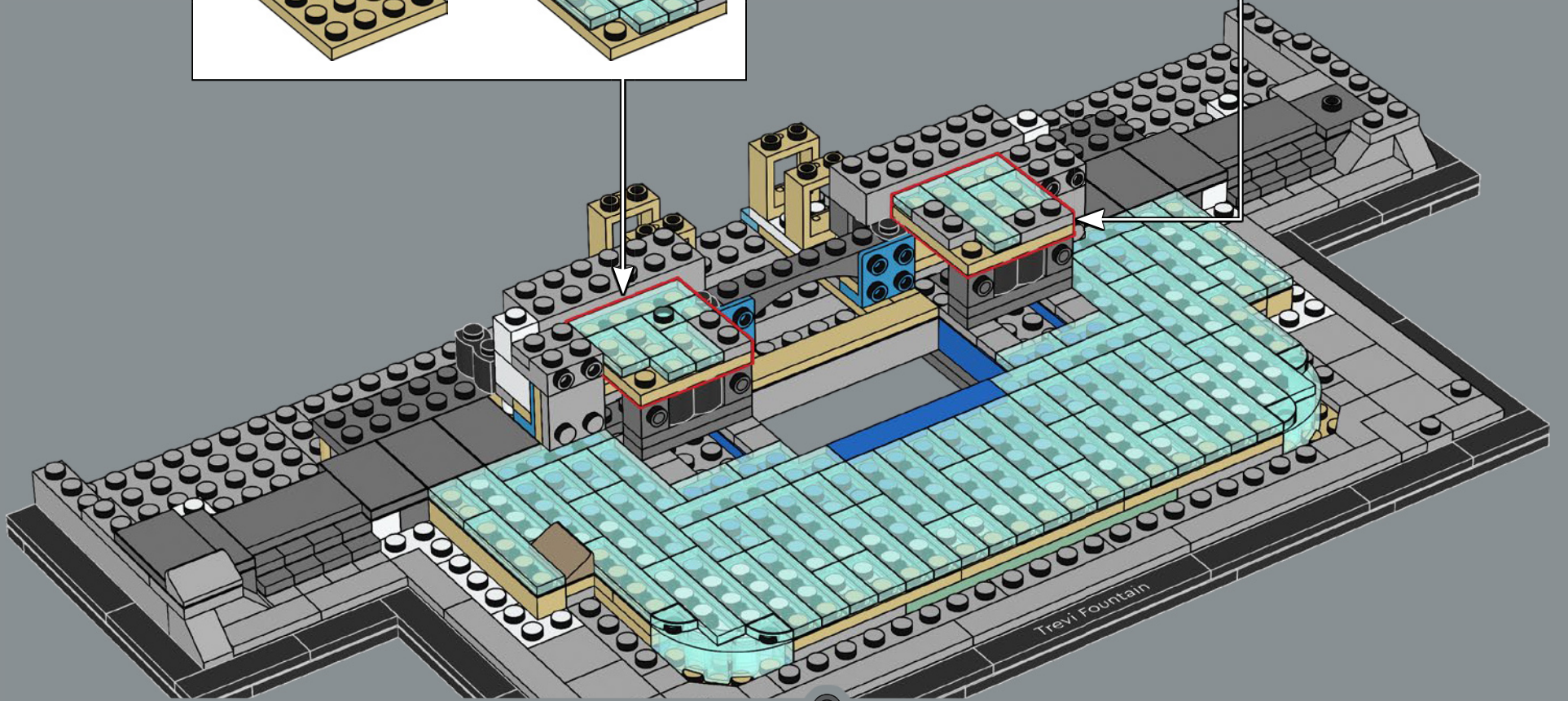
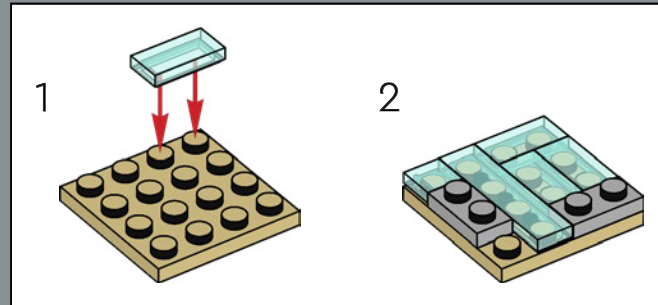
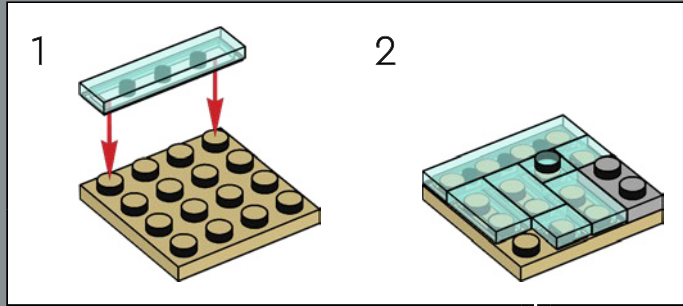

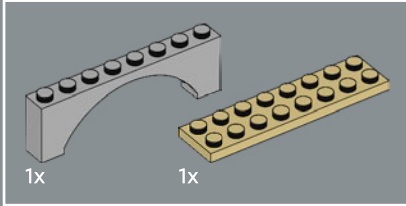
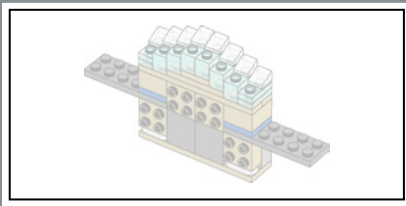

58

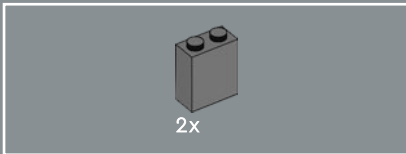
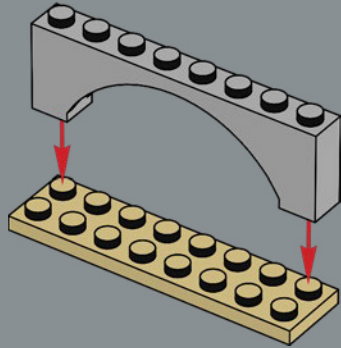

59

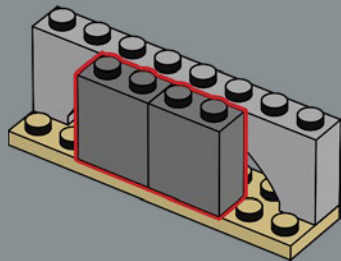

60

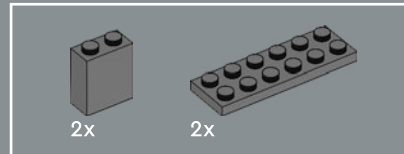
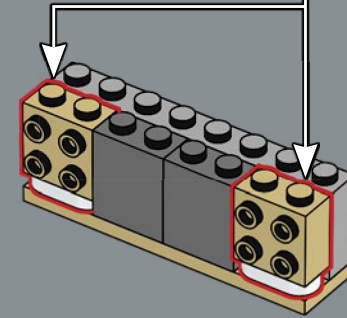
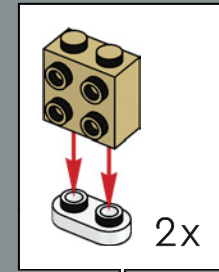

61

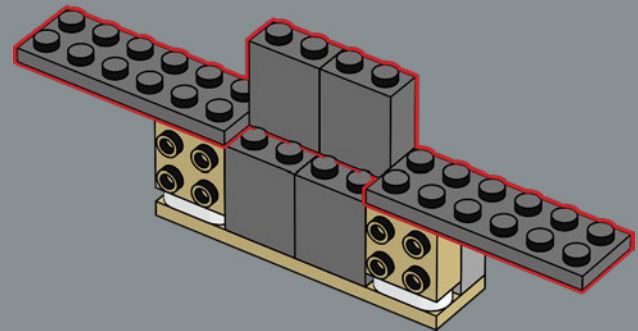

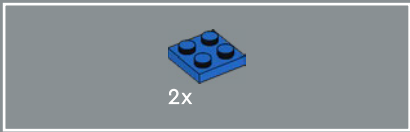

62

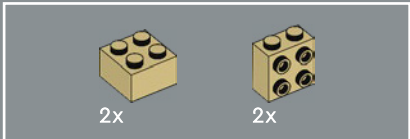
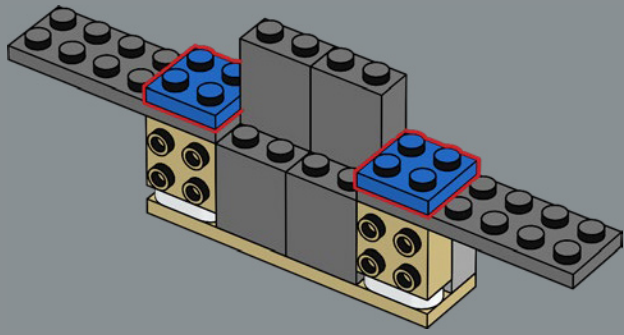

63

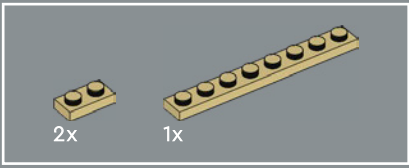
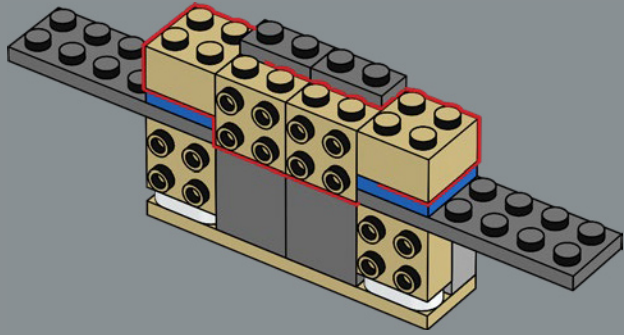

64

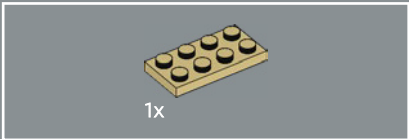
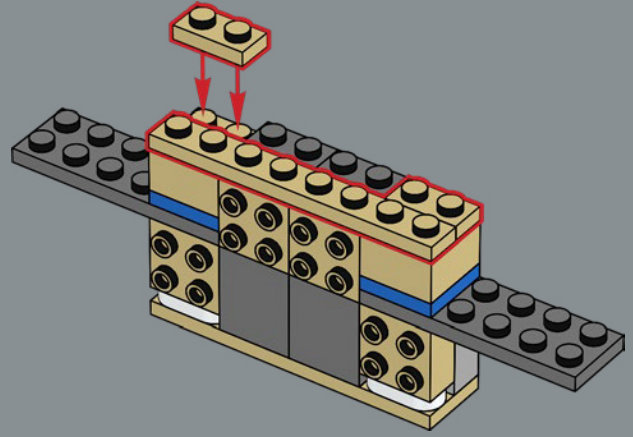

65

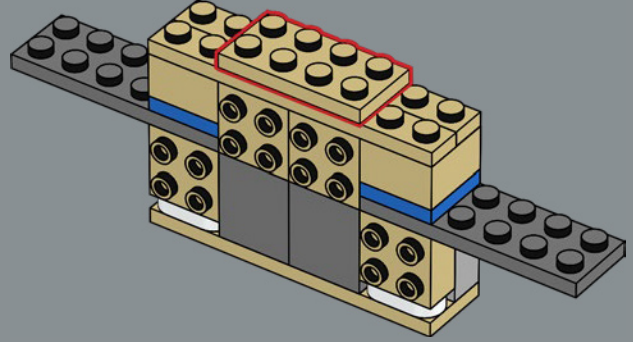

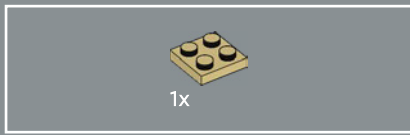

66

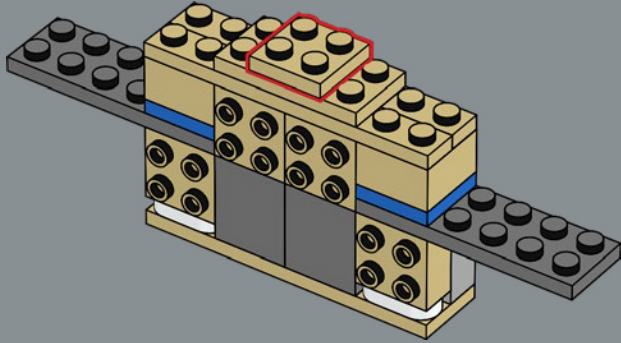

67

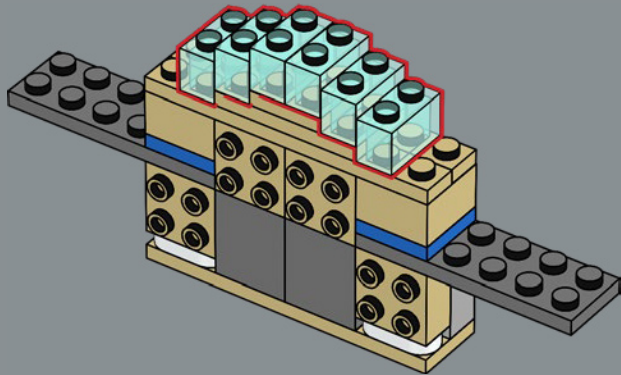

68

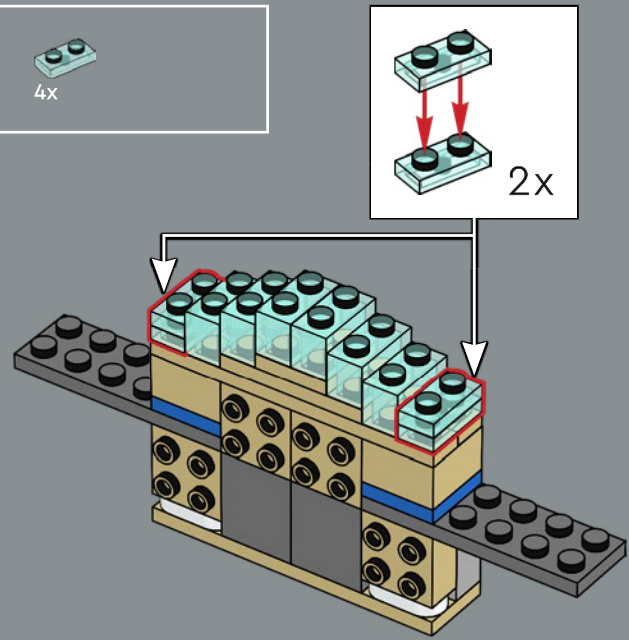

69

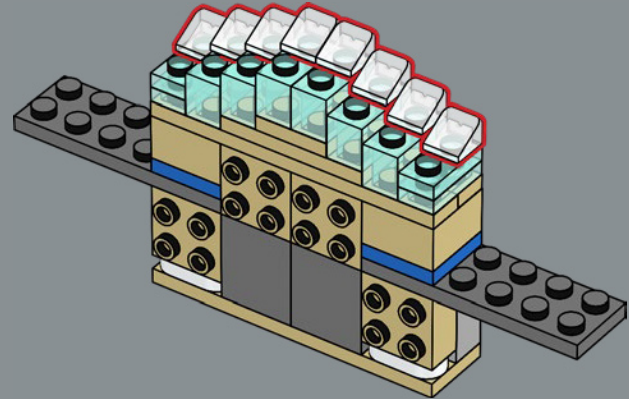

Construite à l'extrémité de l'ancien aqueduc Acqua Vergine, la fontaine de Trevi est aujourd'hui encore alimentée par l'eau de plusieurs aqueducs.

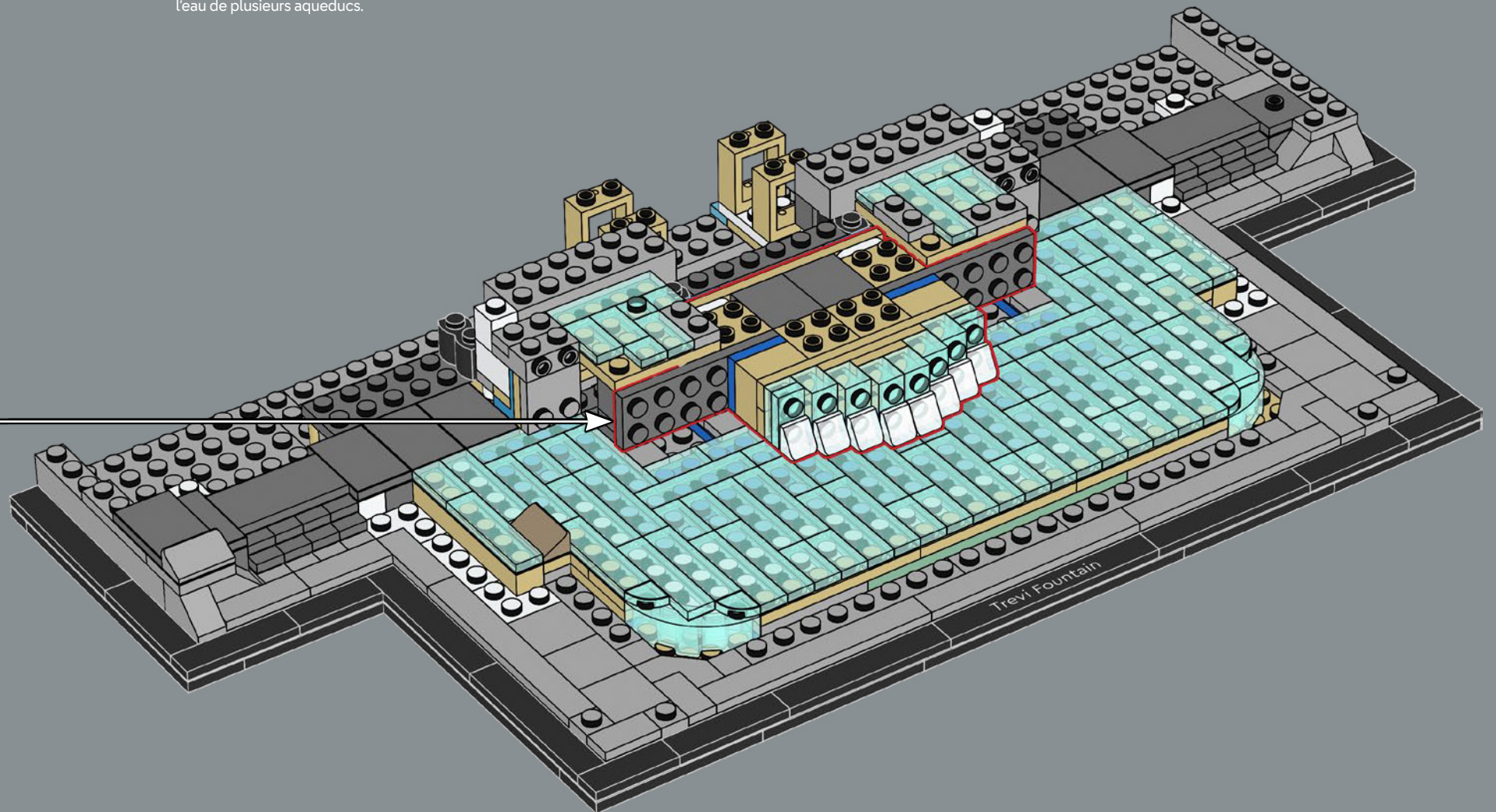

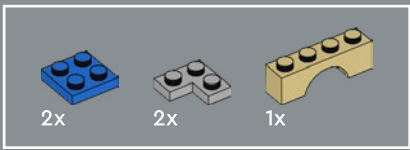

72

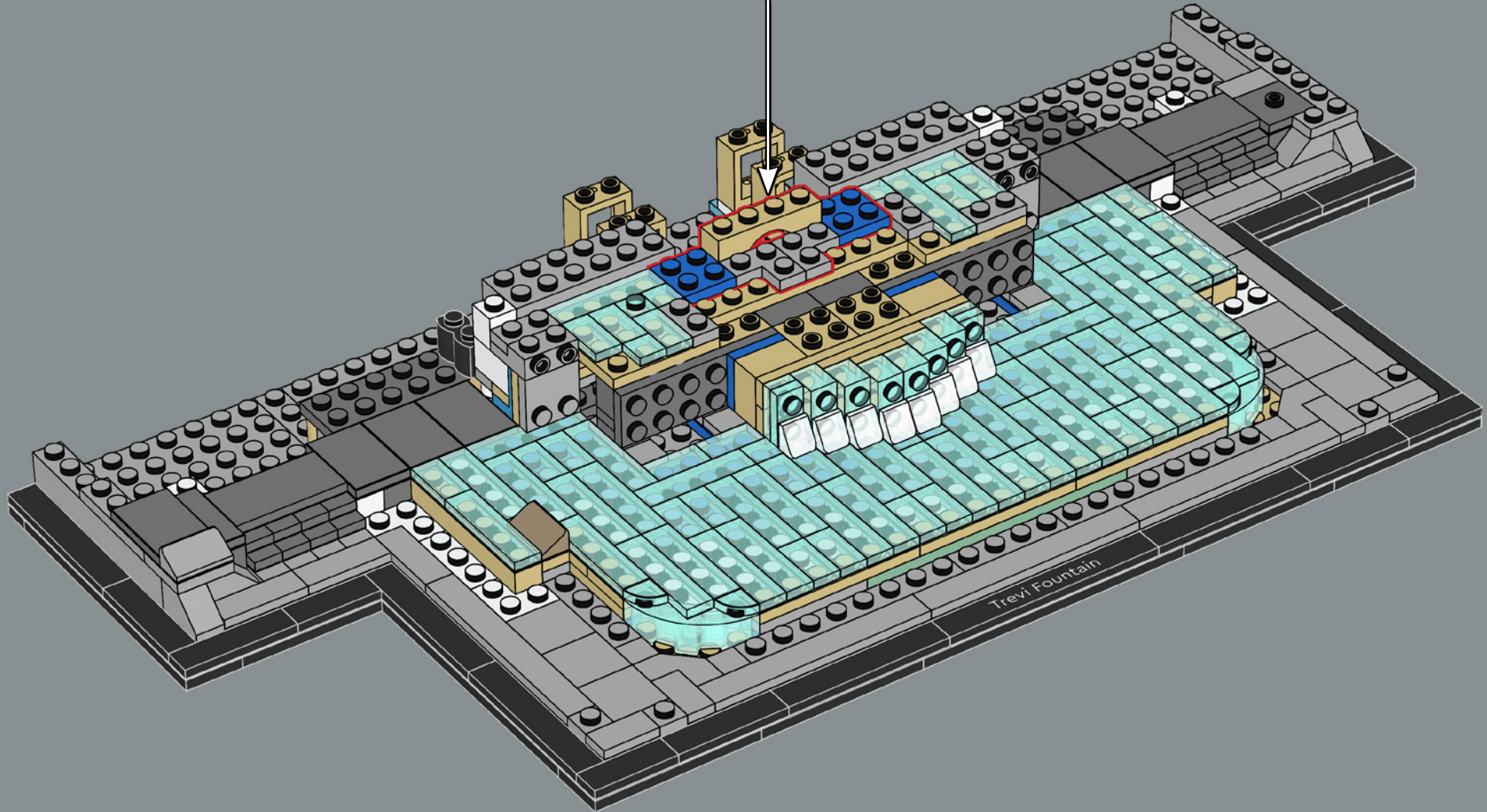
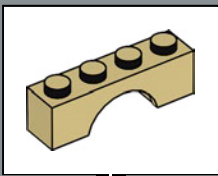

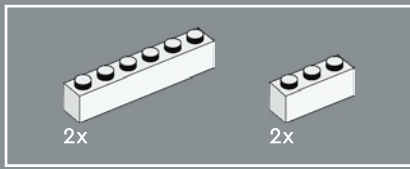

73

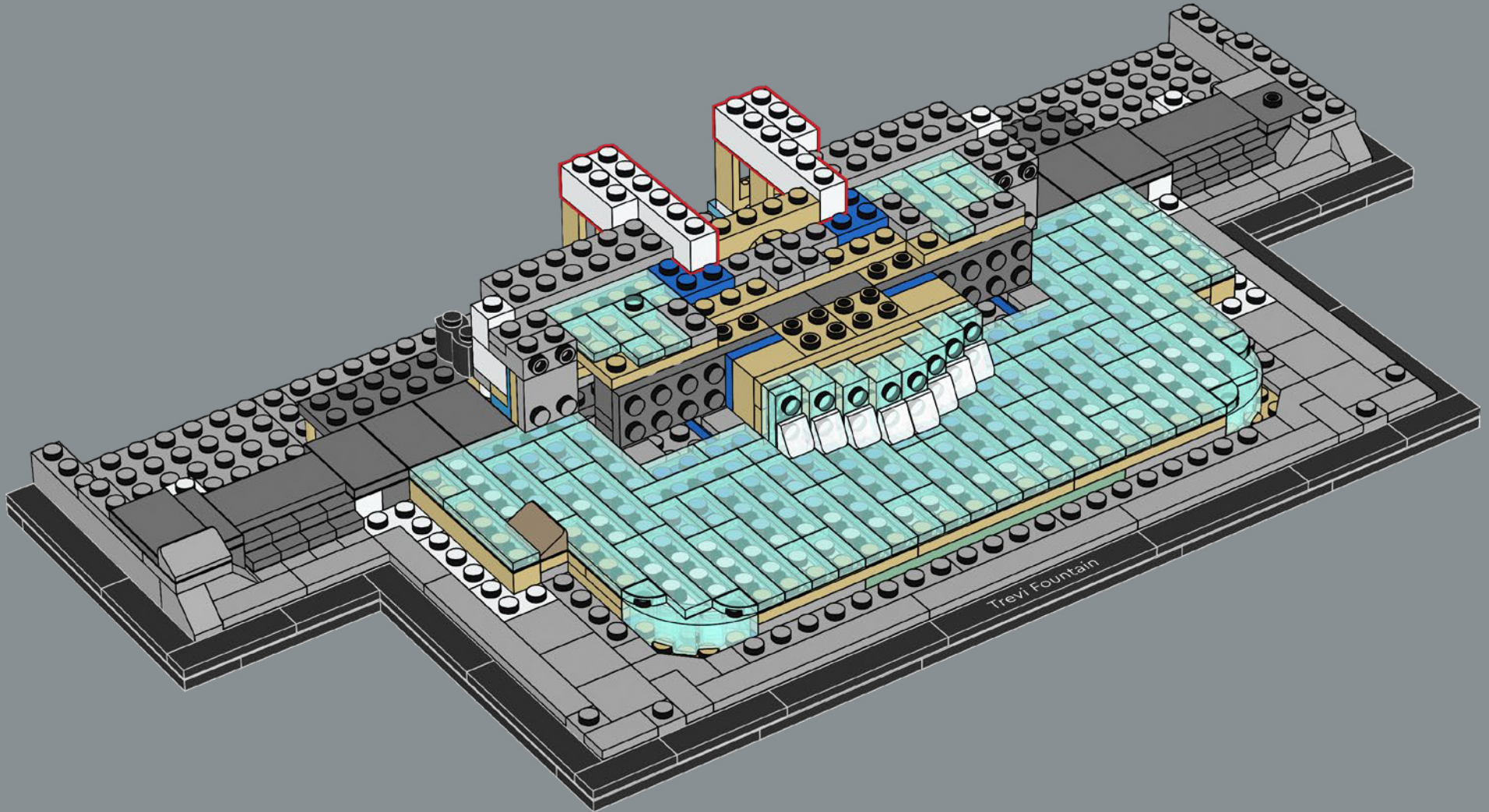

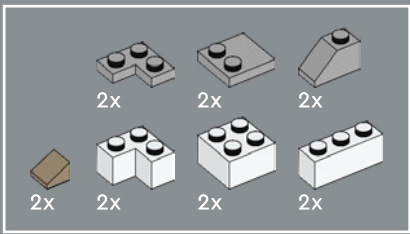

74

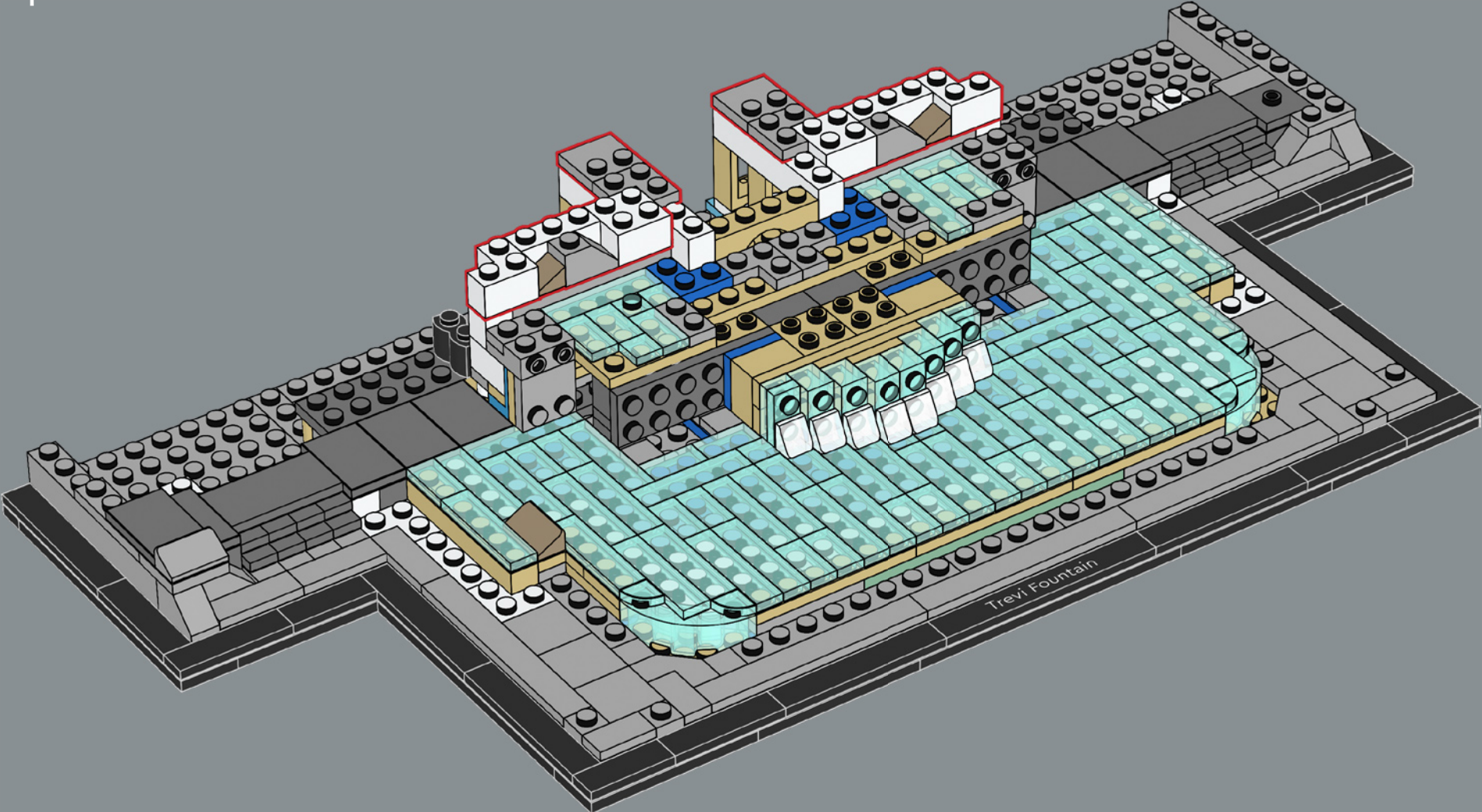

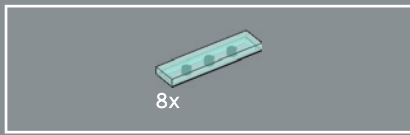

75

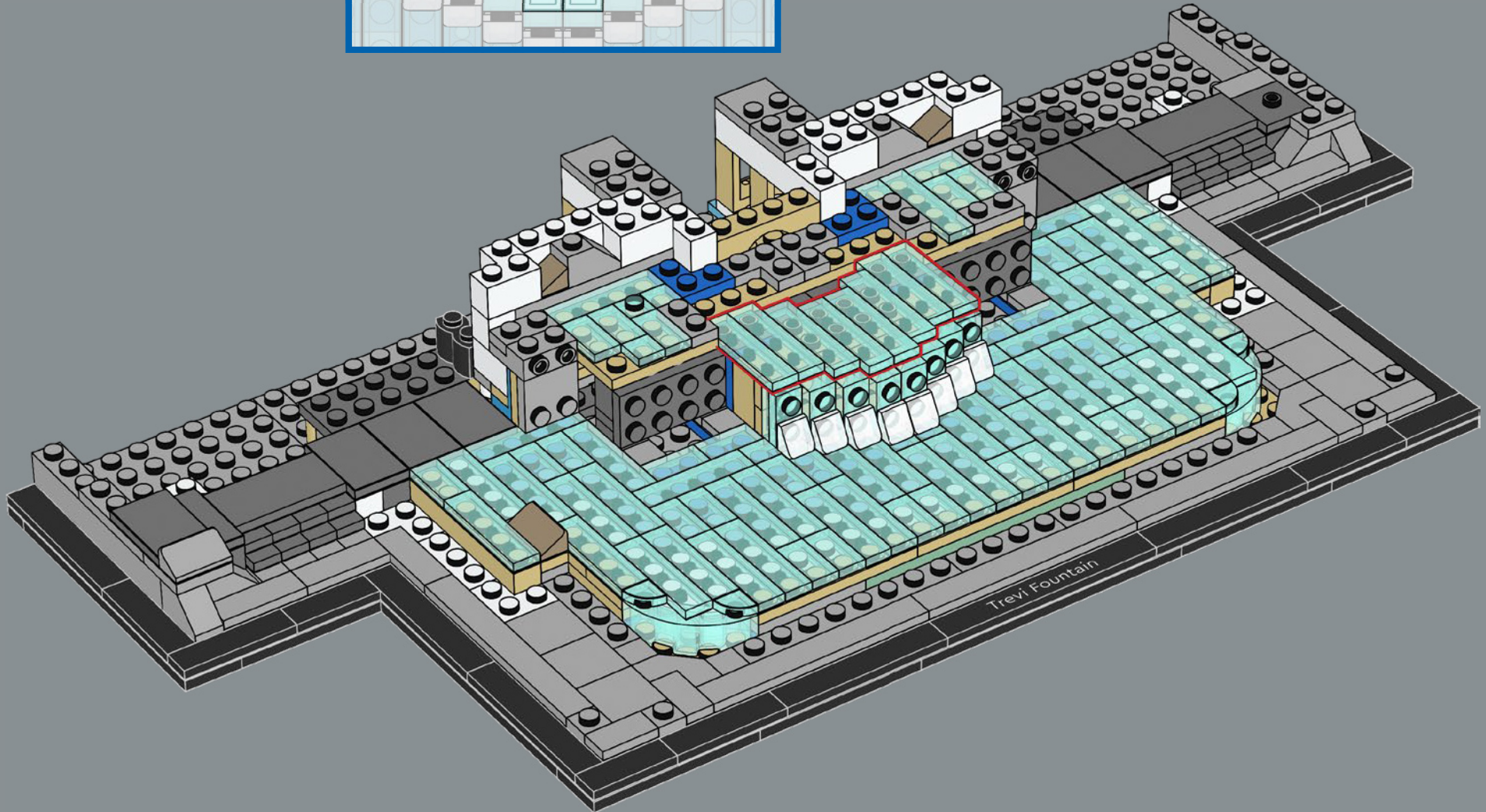
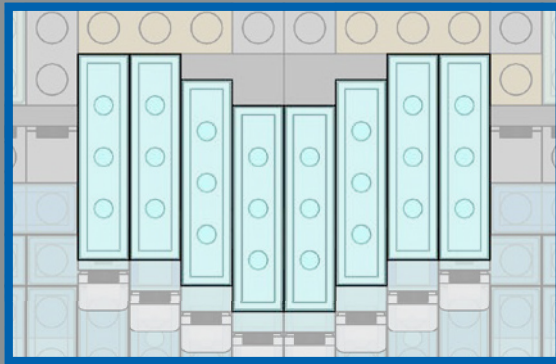

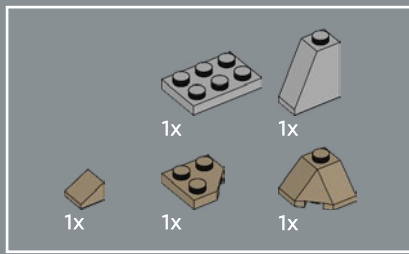

76

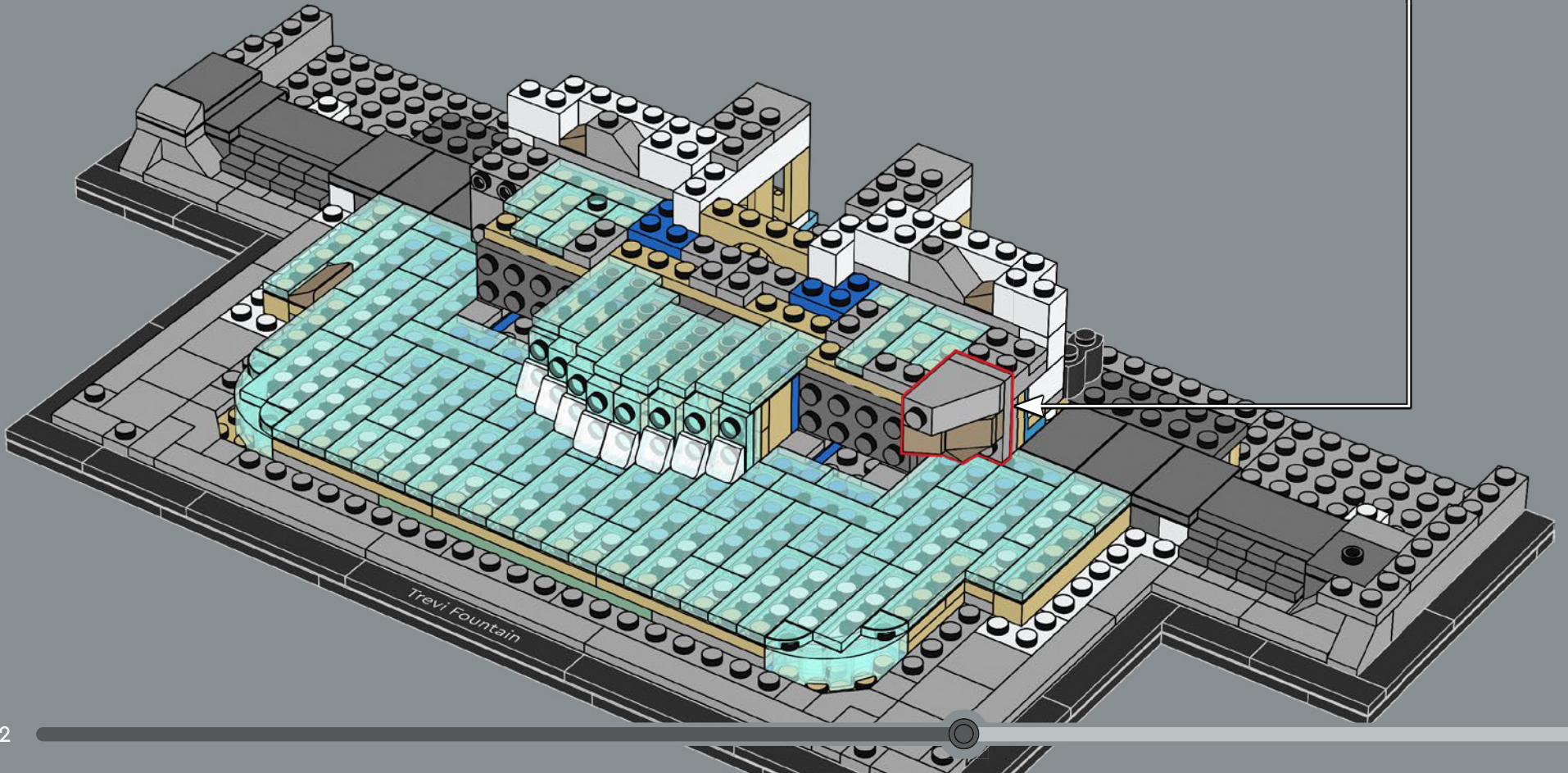
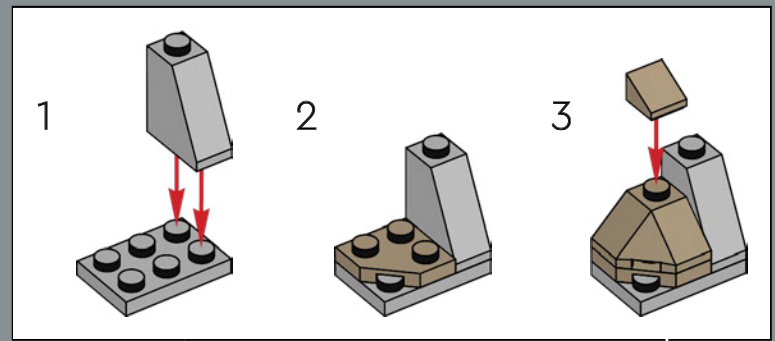

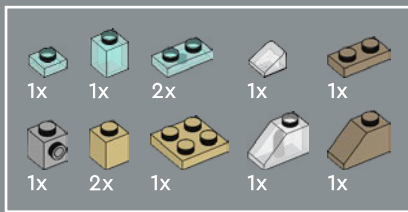

77

1

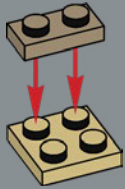

2

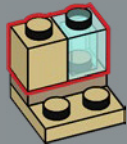

3

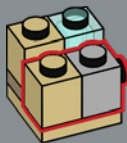

4



5



6

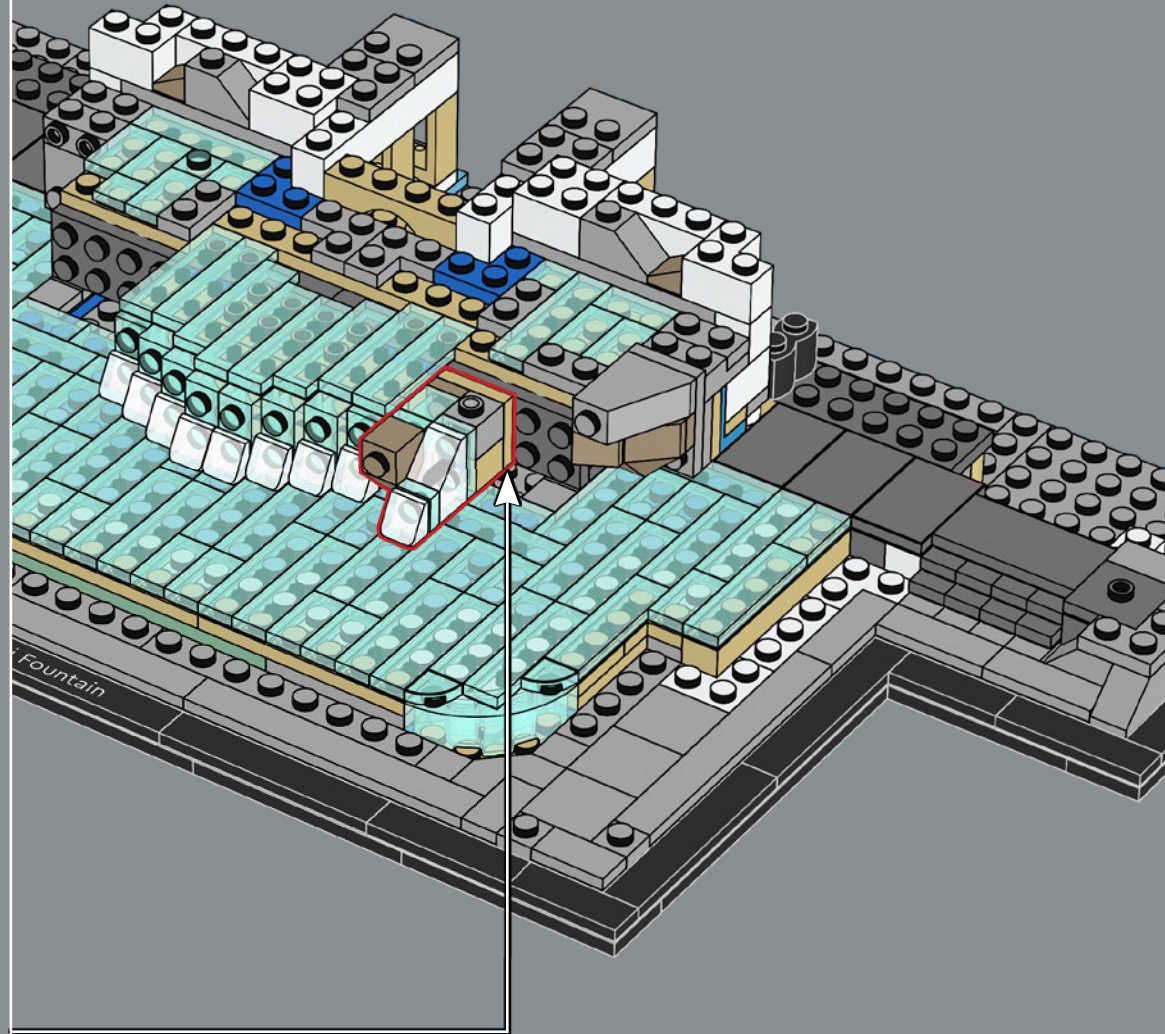

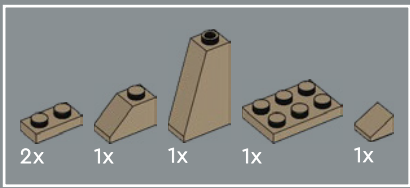

78

1

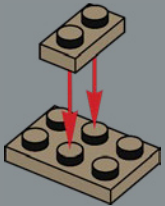

2

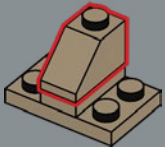

3

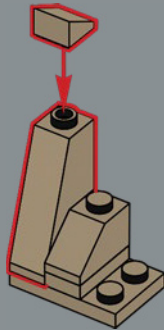

4

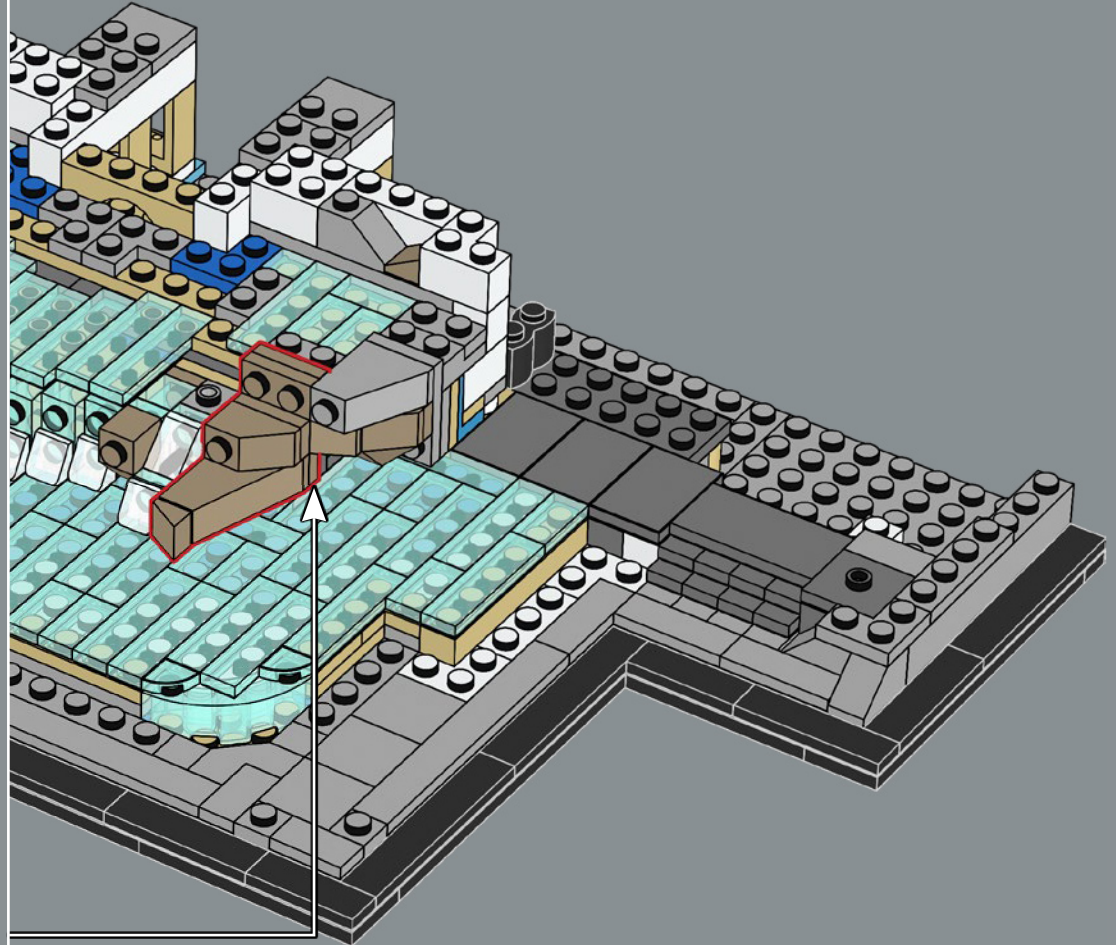
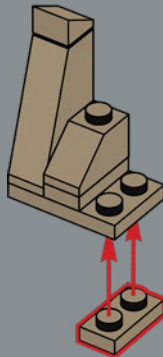

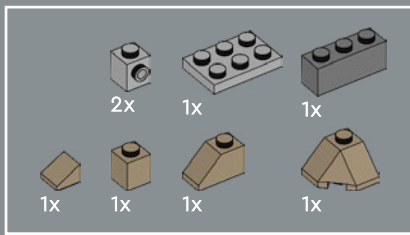

79

1

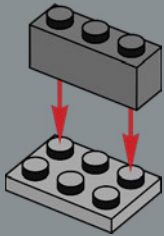

2

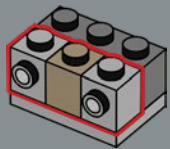

3

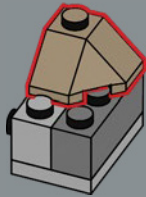

4

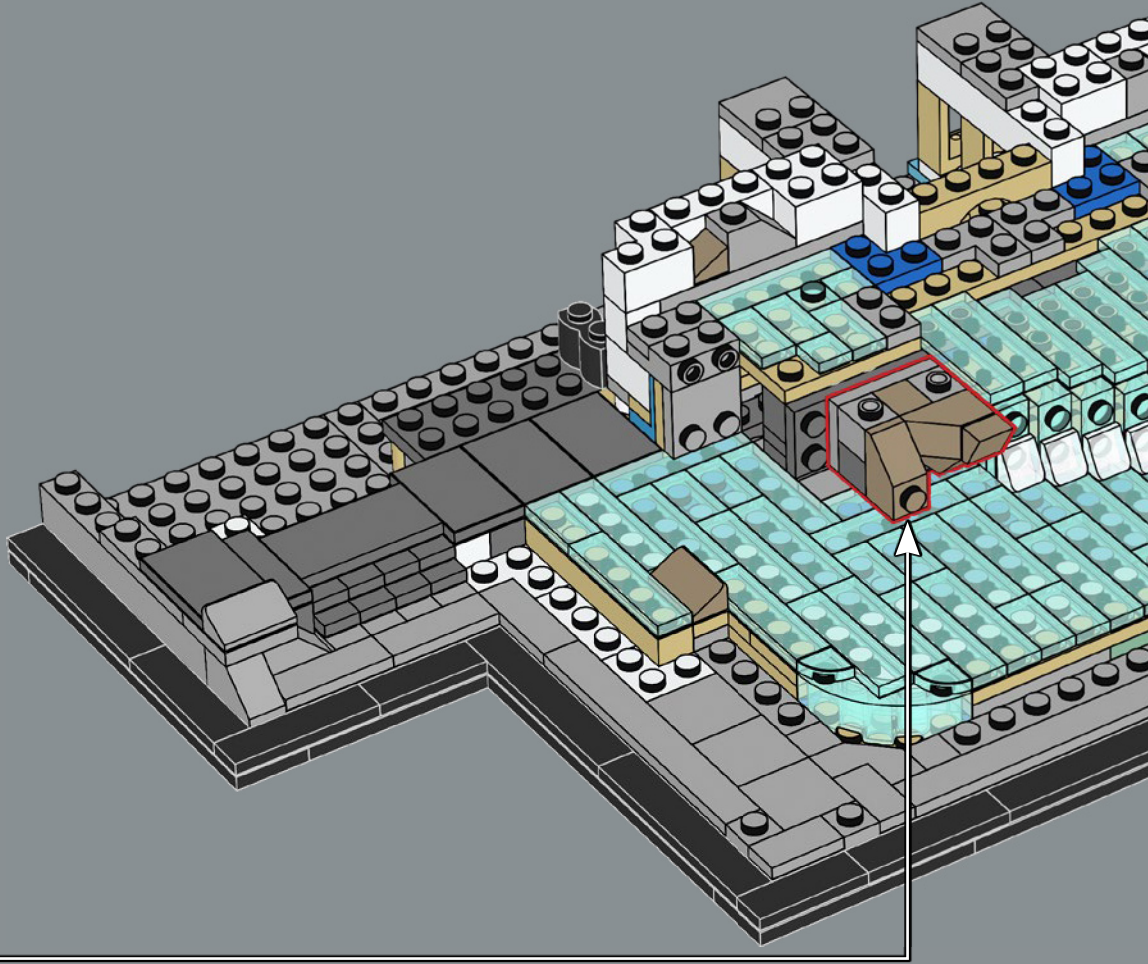
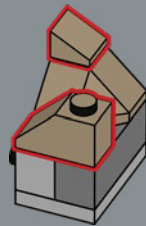

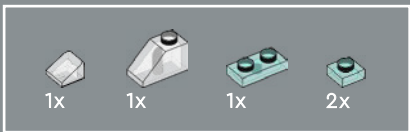

80

1

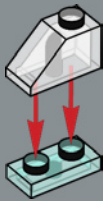

2

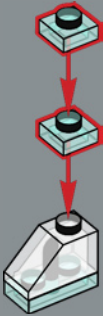

3

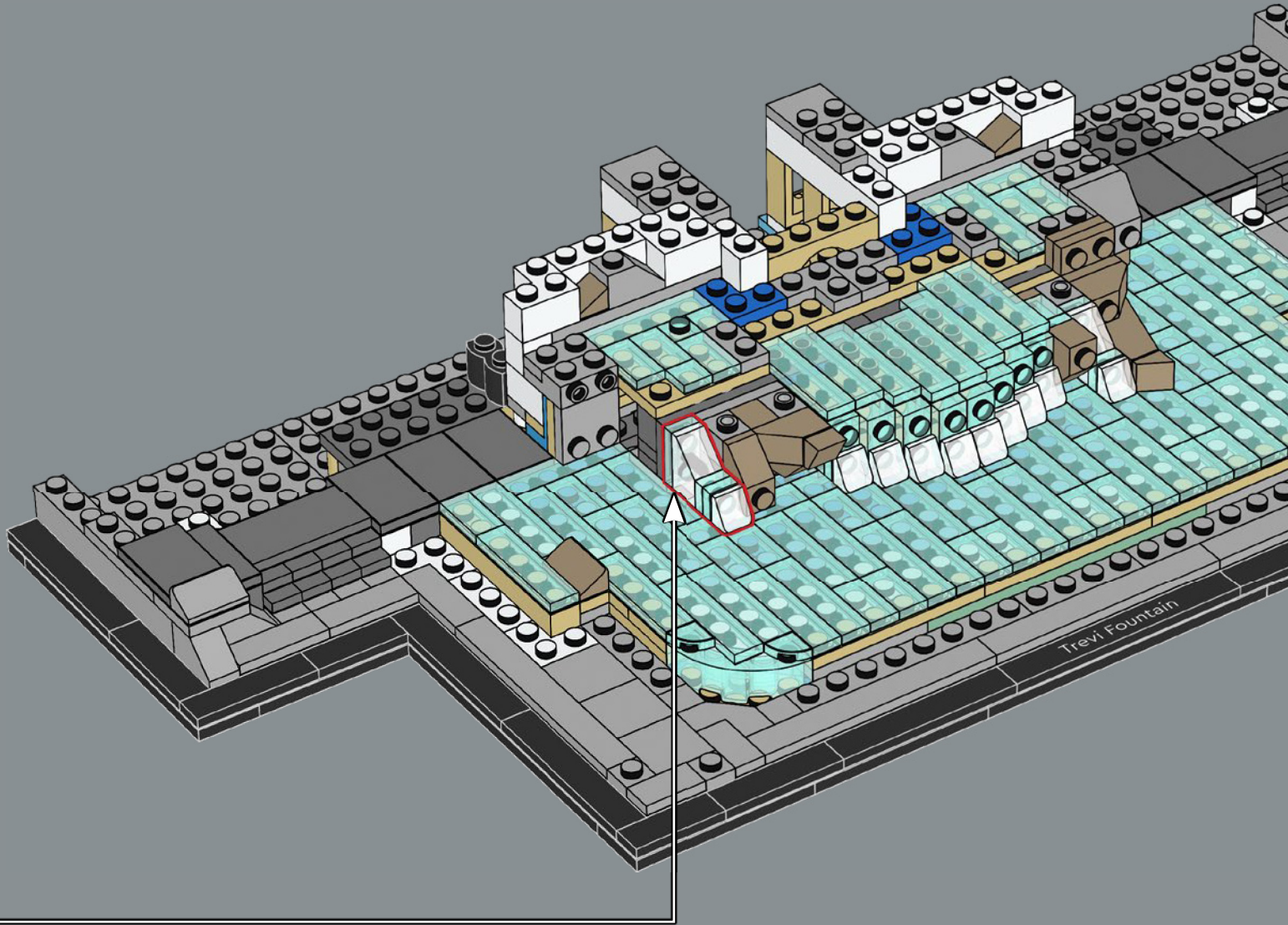

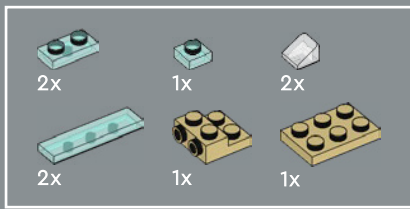

81

1

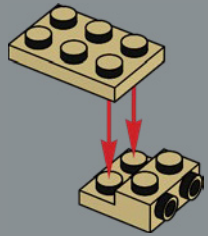

2

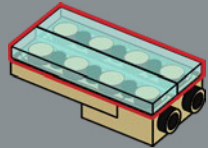

3

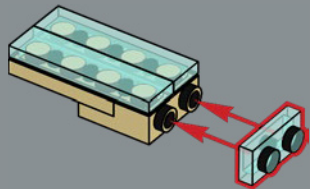

4

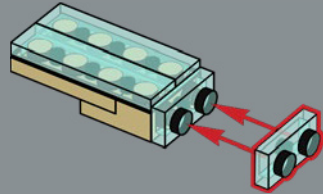

5

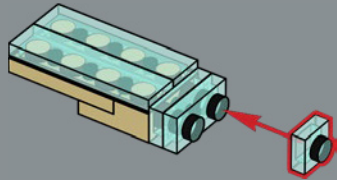

6

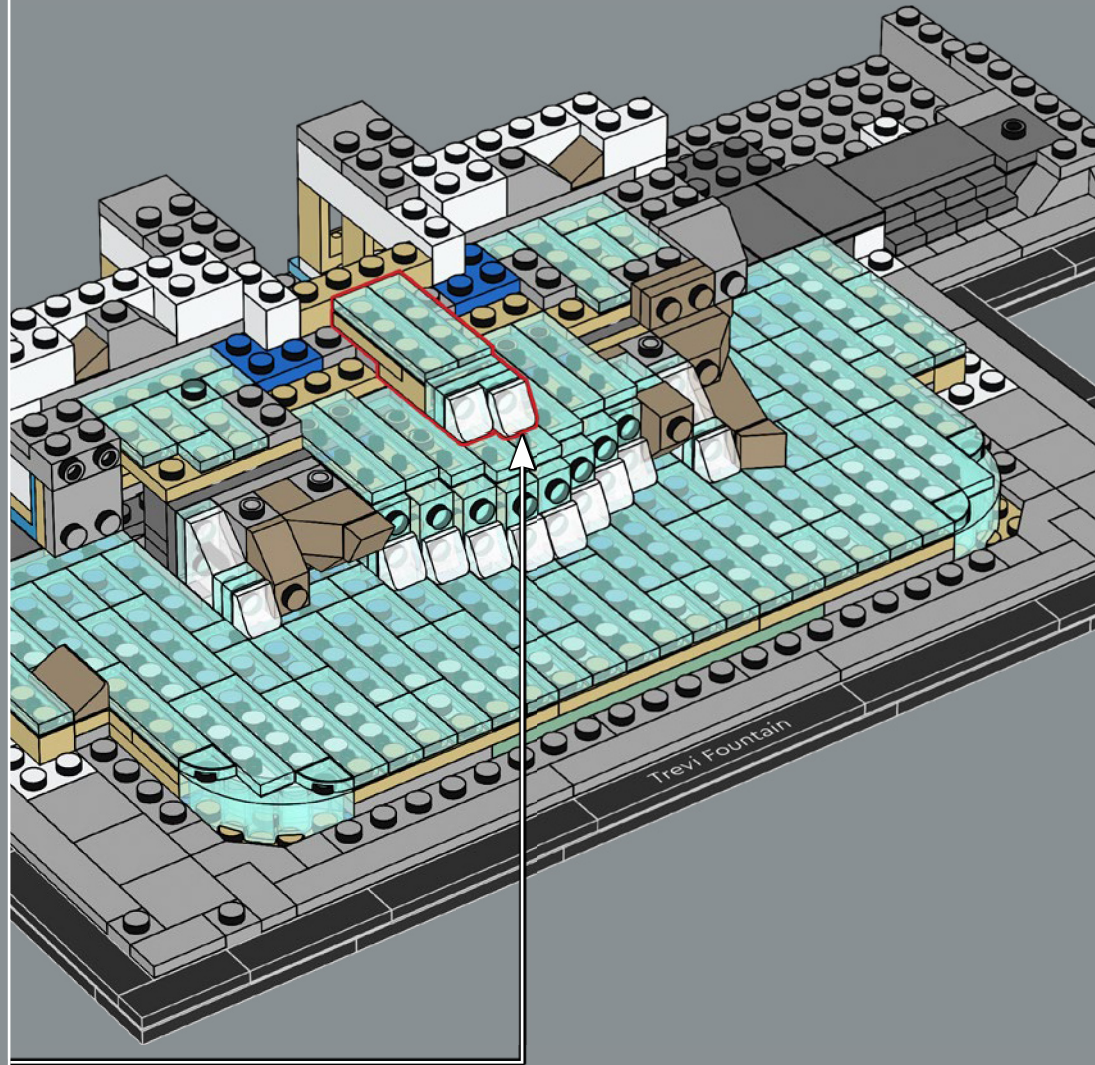
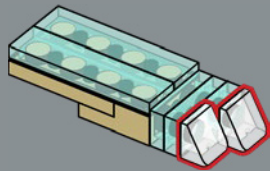

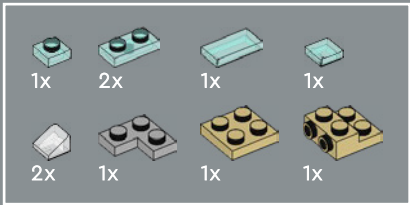

82

1

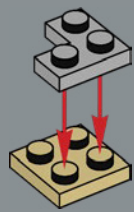

2

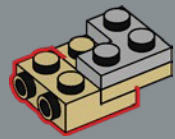

3

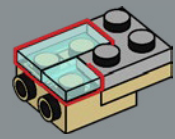

4

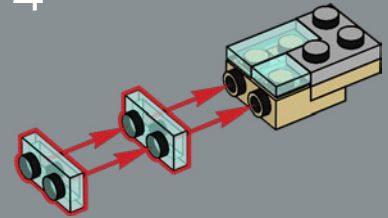

5

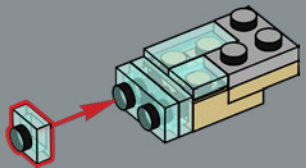

6

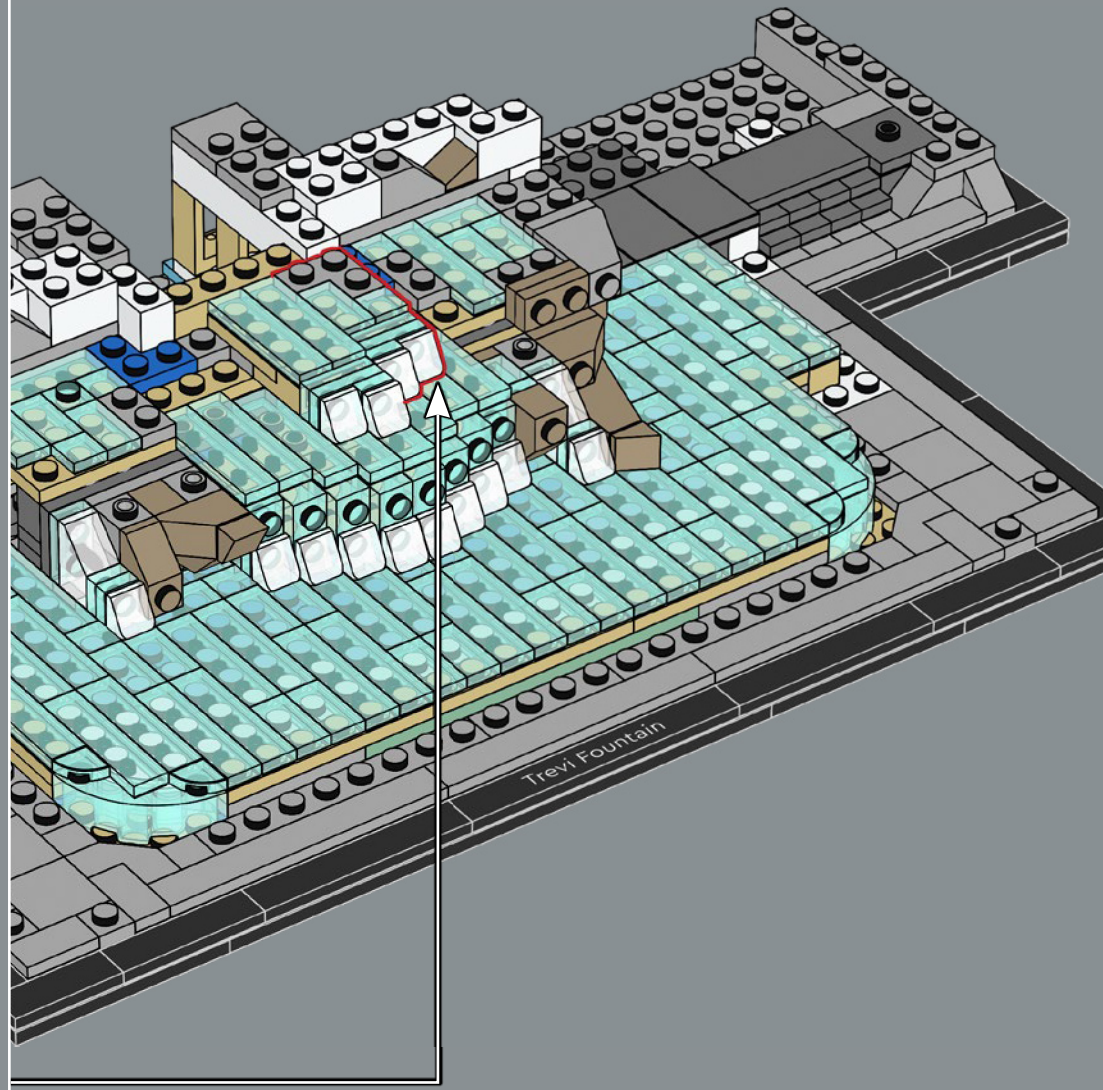
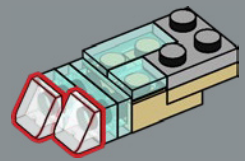

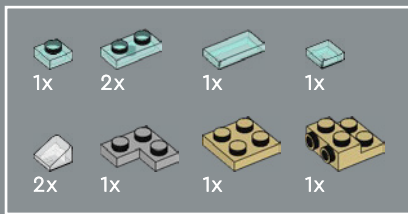

83

1

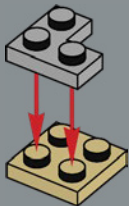

2

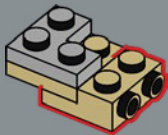

3

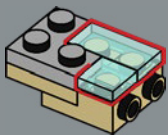

4

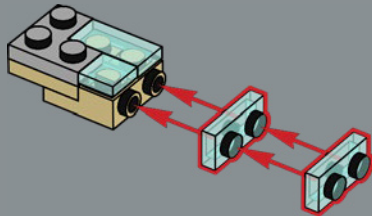

5

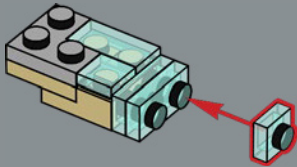

6

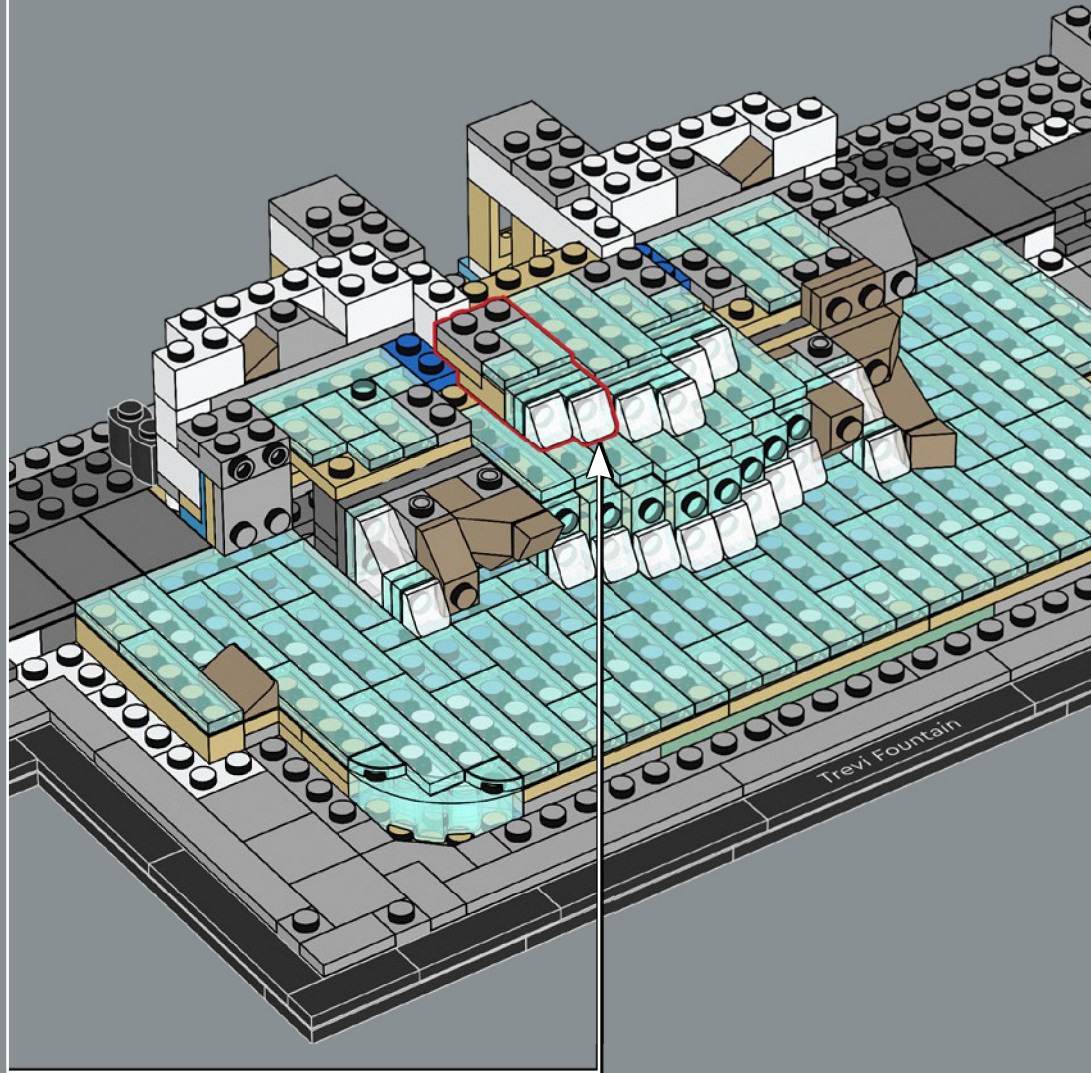
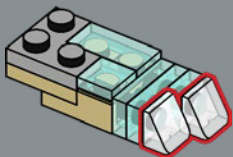

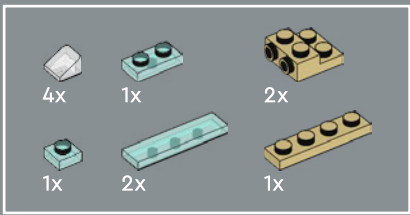

84

1

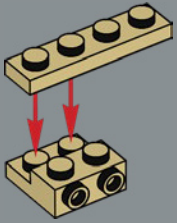

2

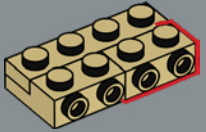

3

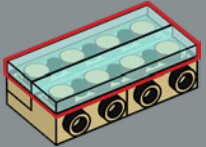

4

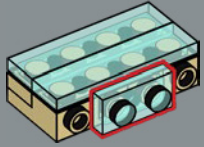

5

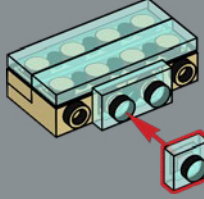

6

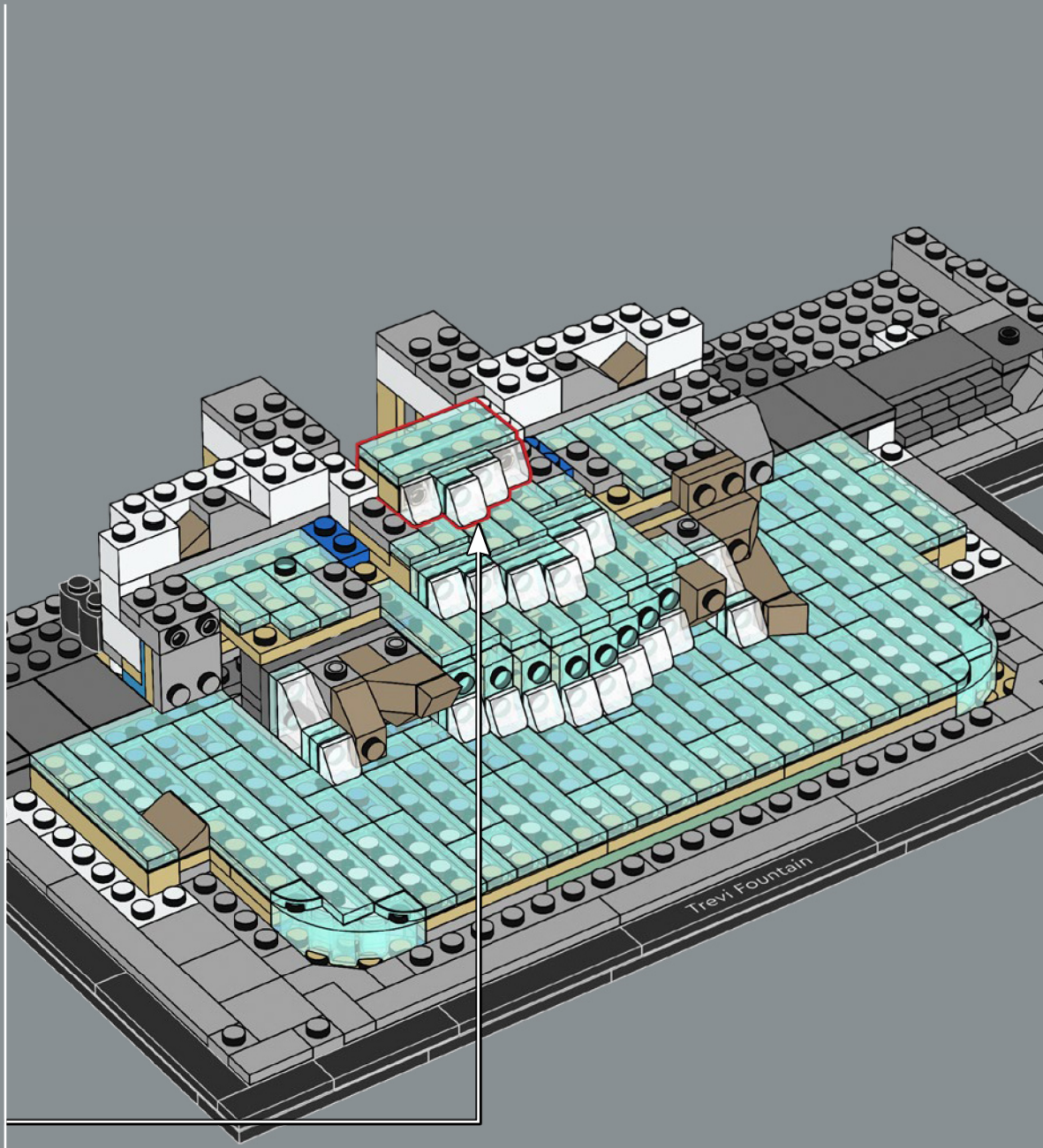
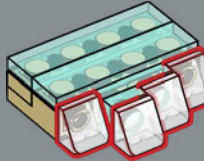

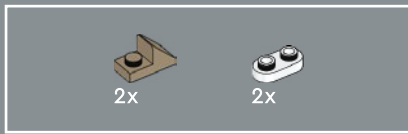

Les différentes nuances sous les briques bleues transparentes reflètent la réalité. Dans les parties les plus hautes, l'eau s'écoule en un mince filet sur la roche, dévoilant la couleur de la pierre en dessous. Mais plus bas dans le bassin, la profondeur est rendue par des nuances de bleu plus foncées.

85

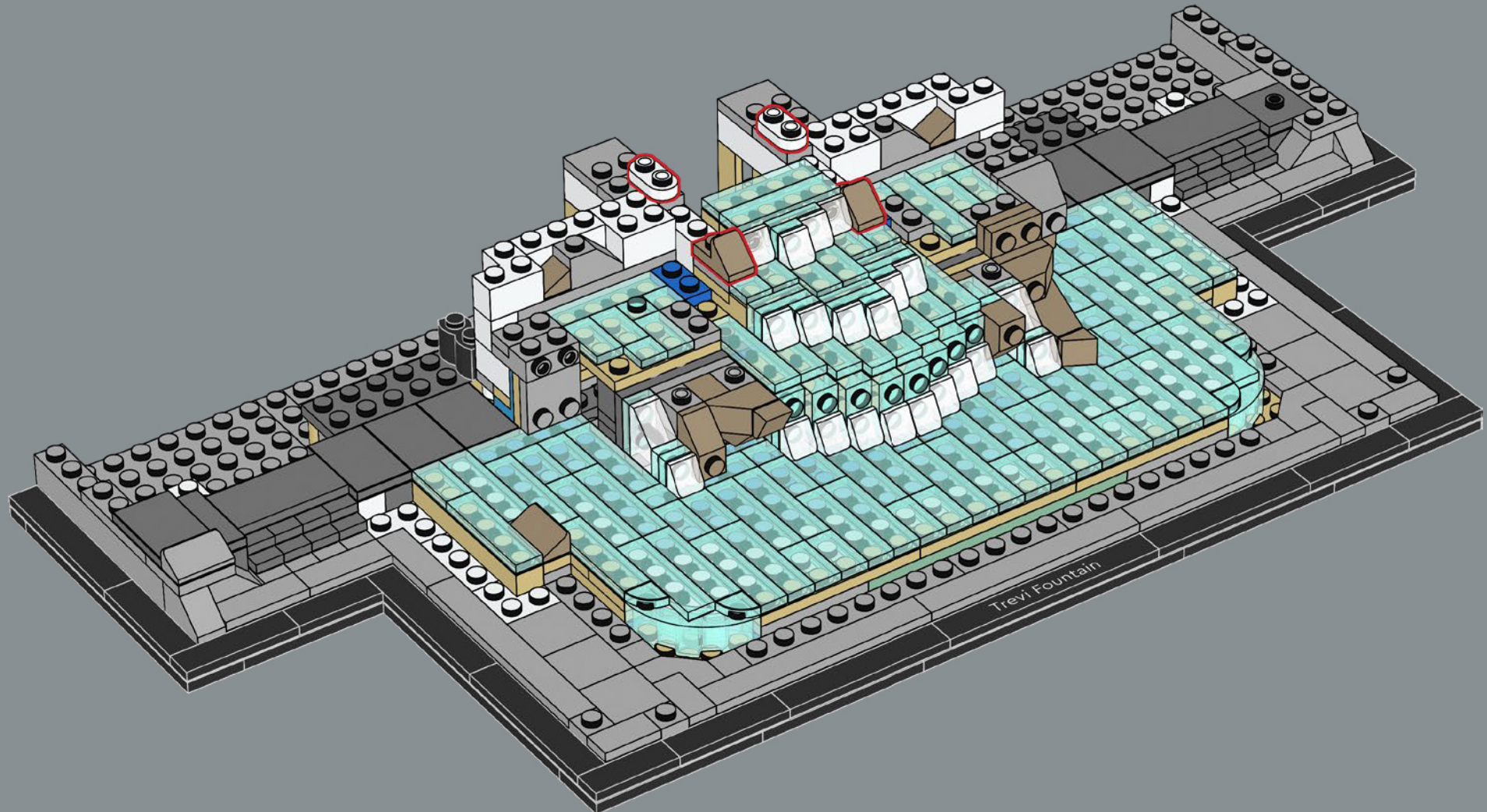

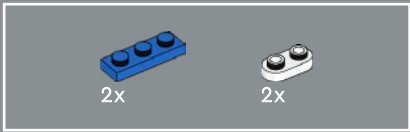

86

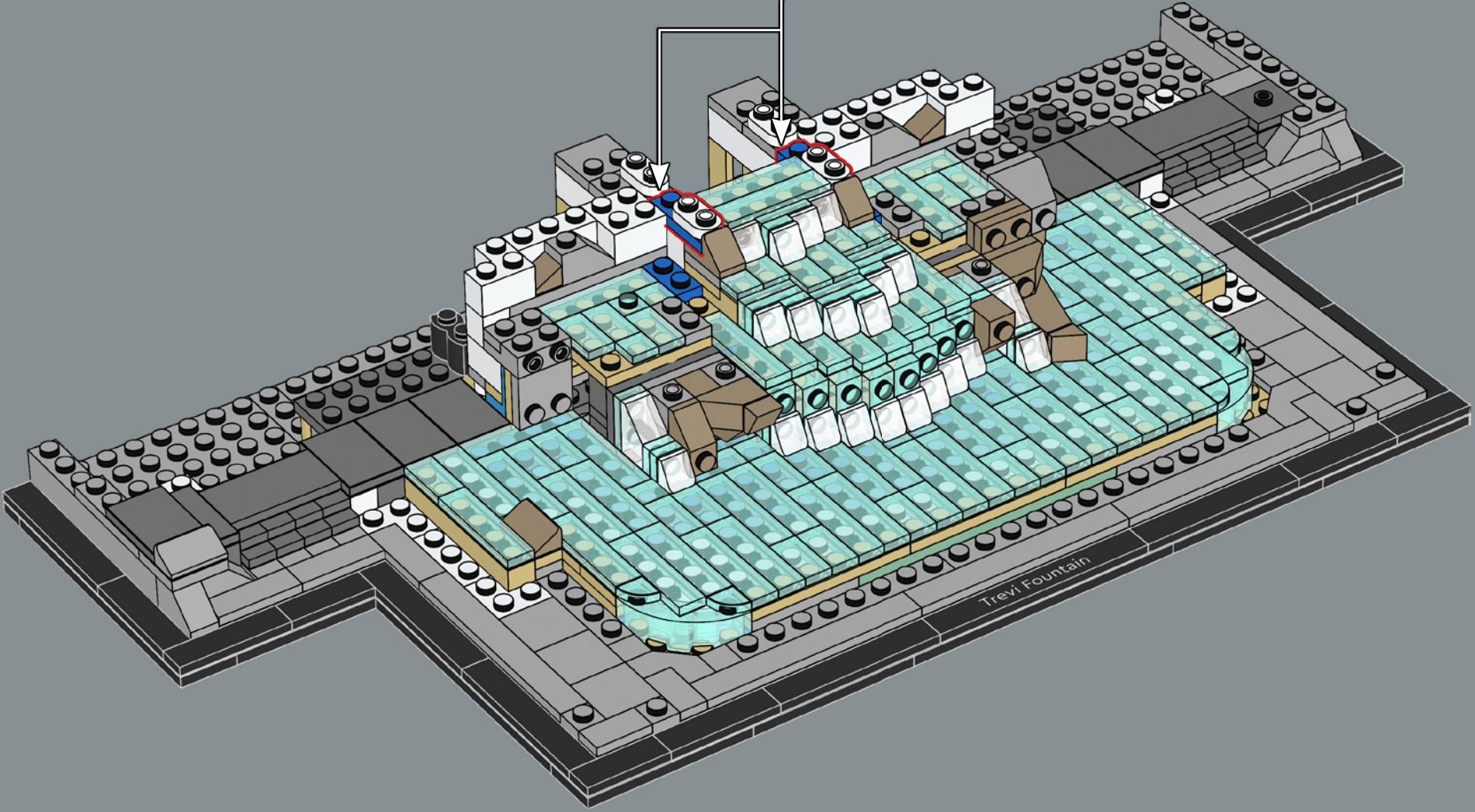
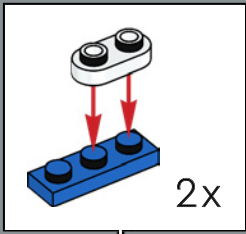

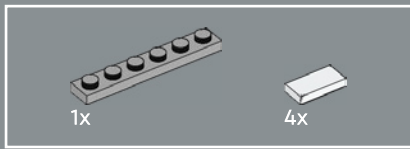

87

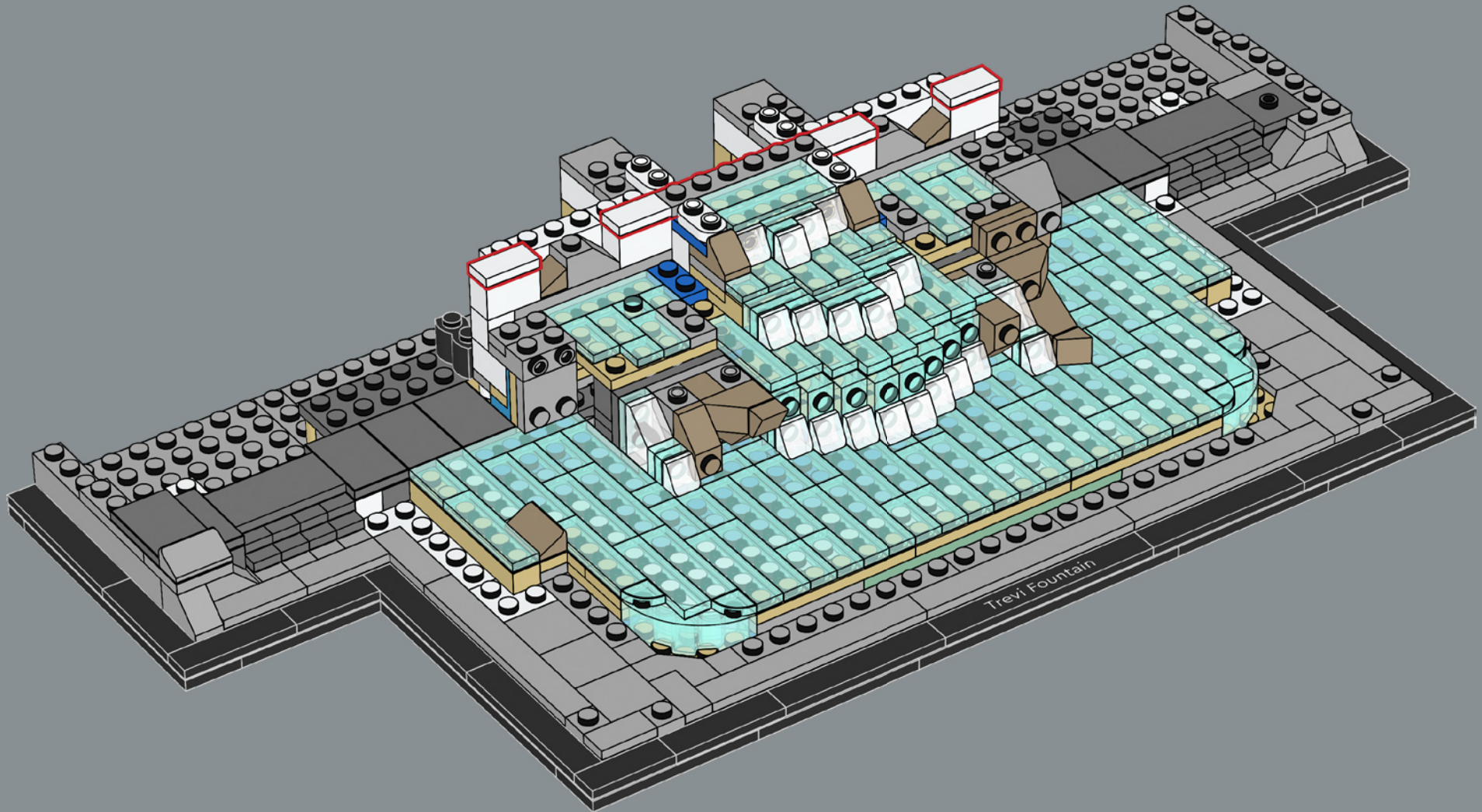

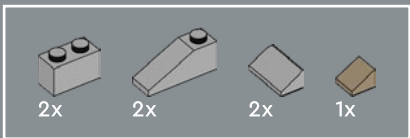

88

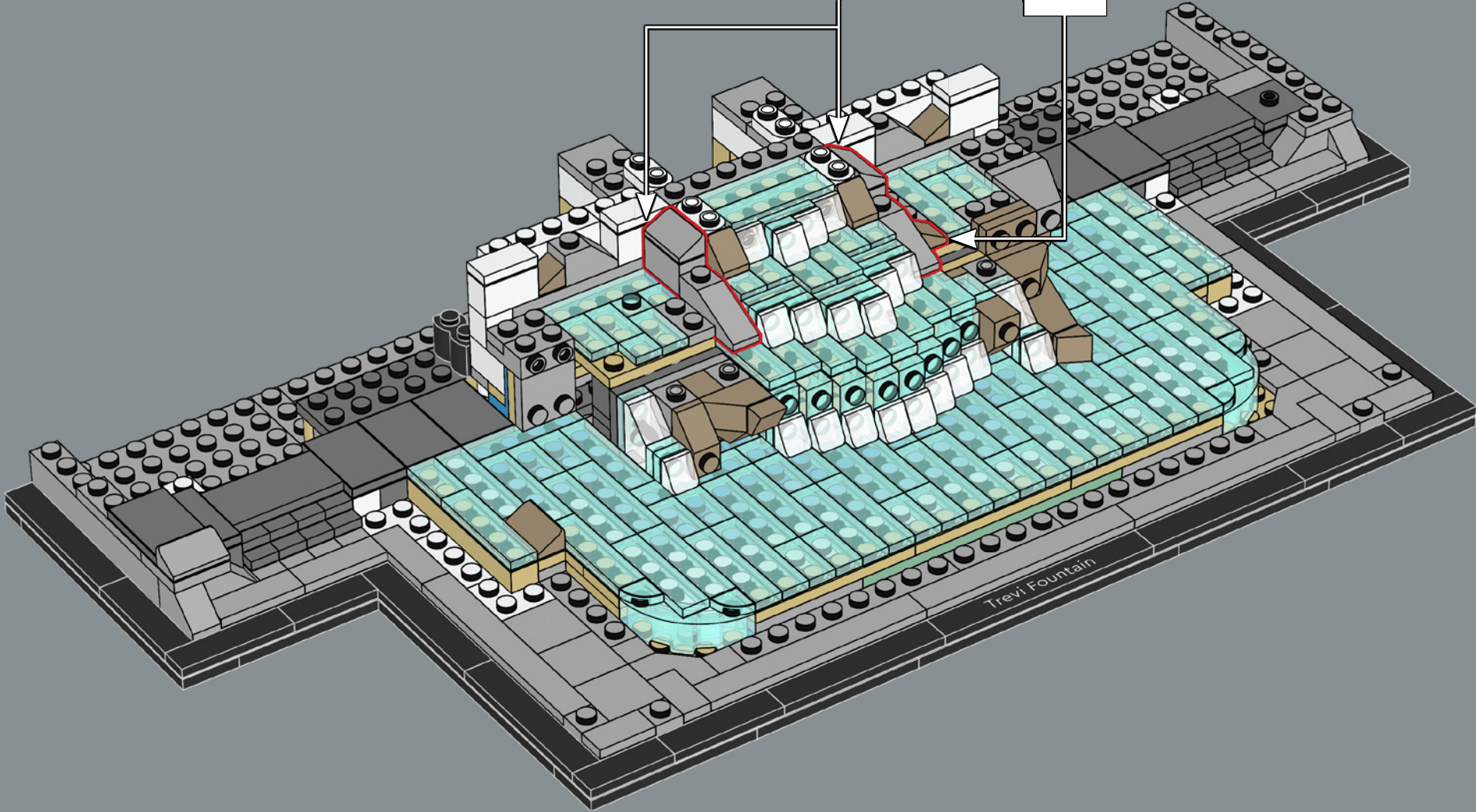
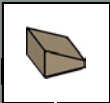
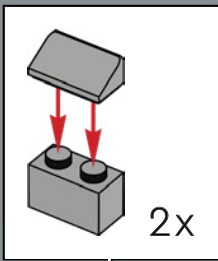

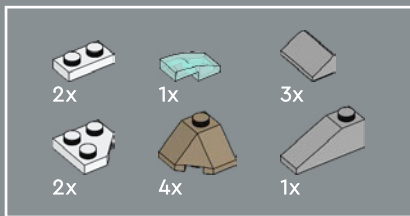

89

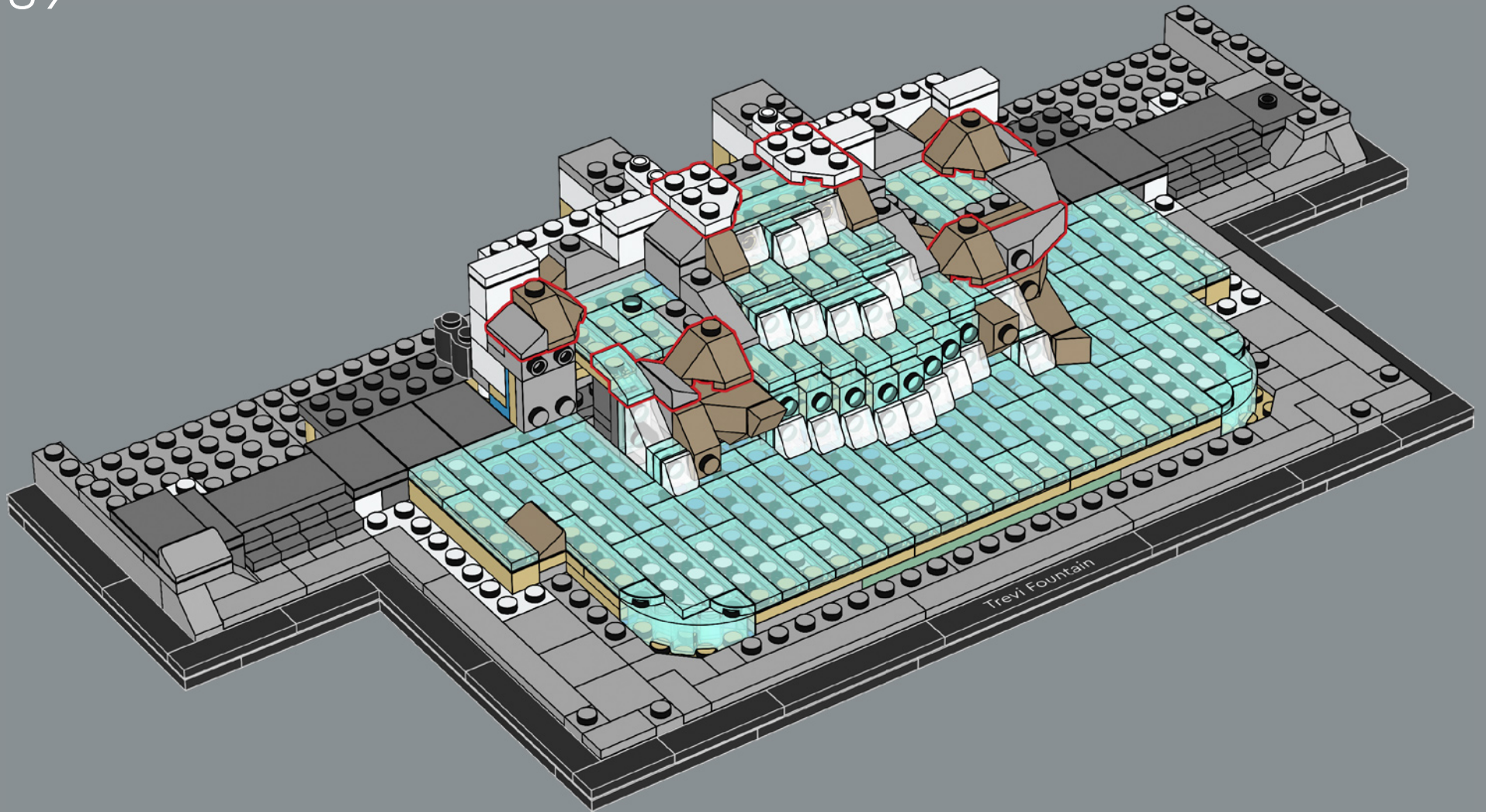

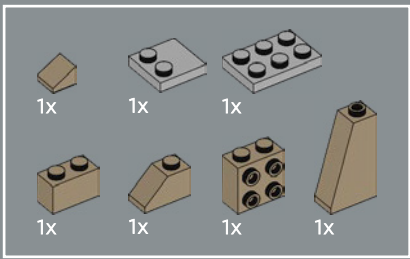

90

1

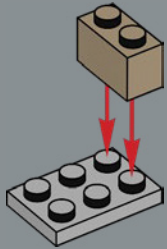

2

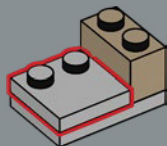

3

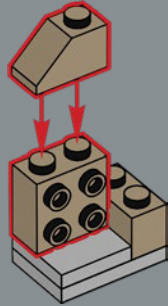

4

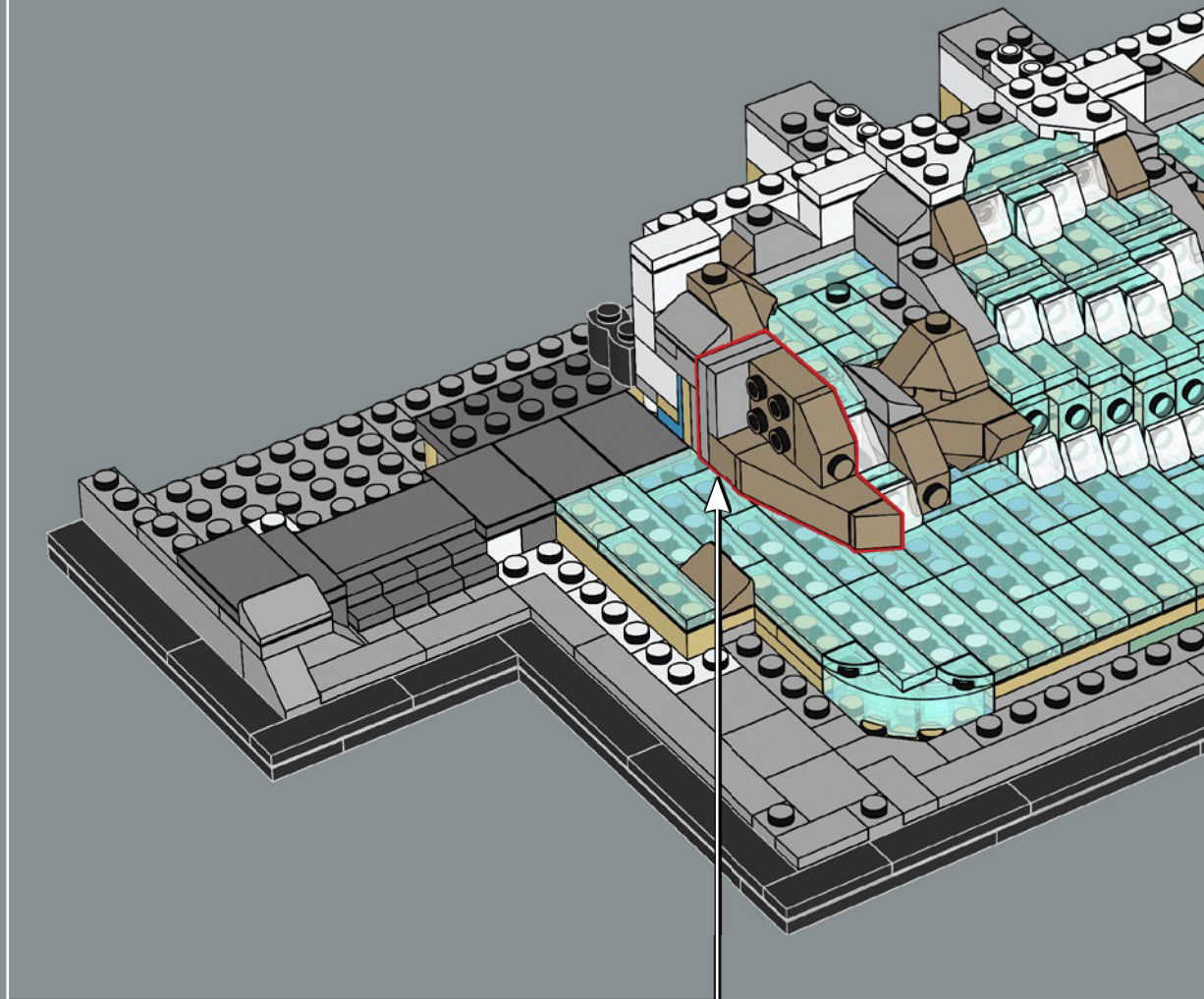
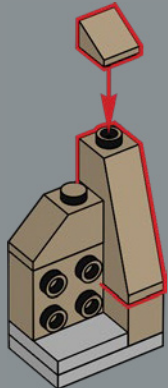

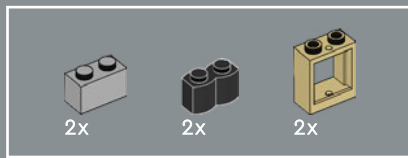

91

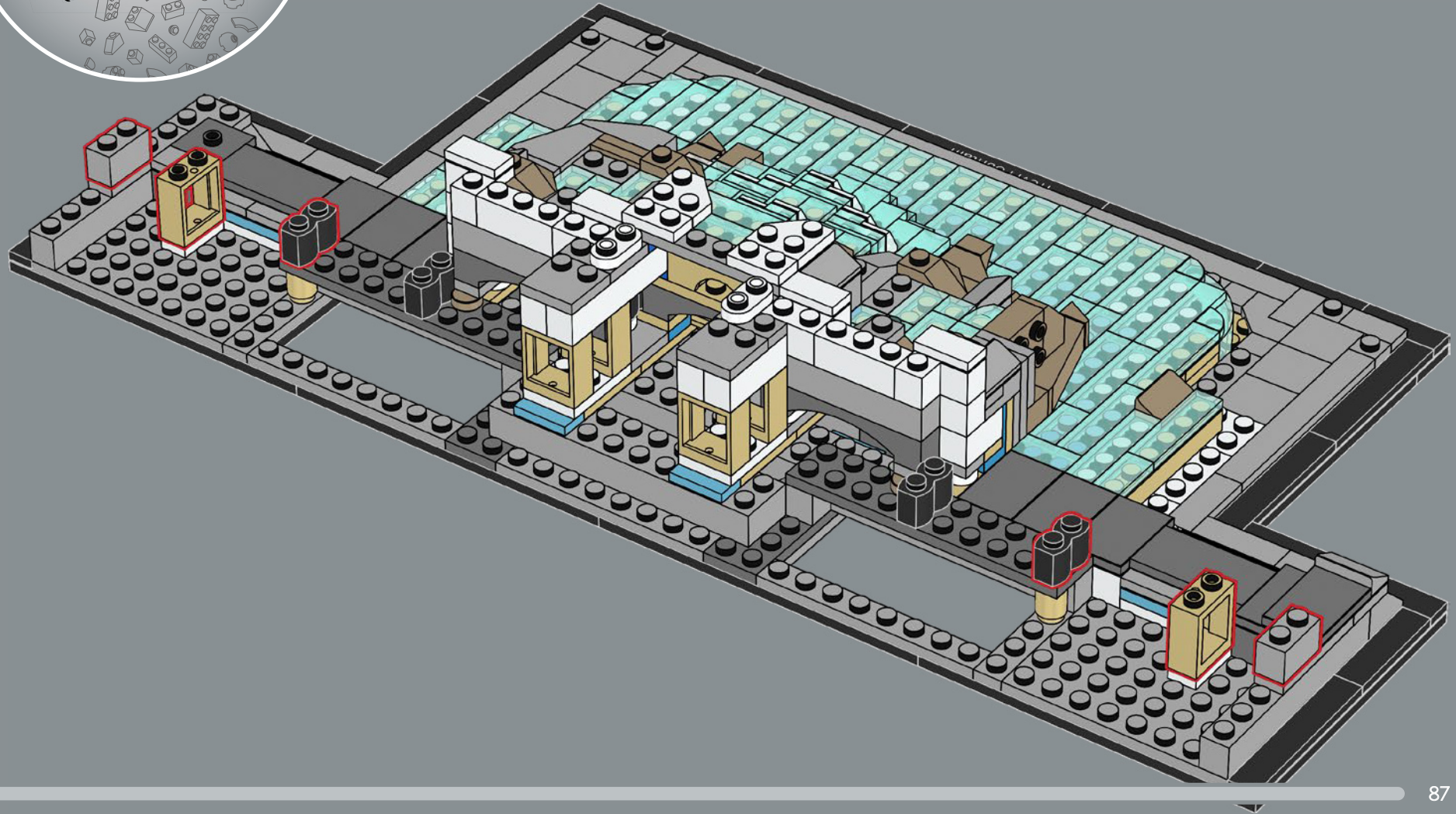

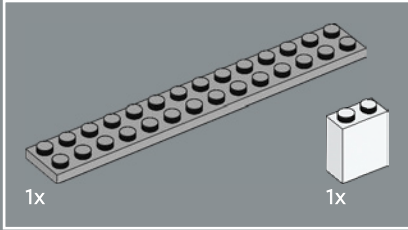
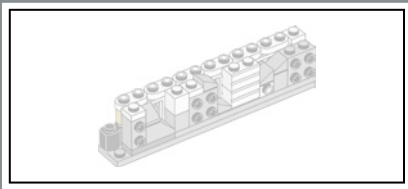

92

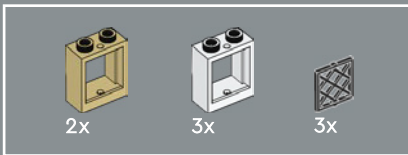
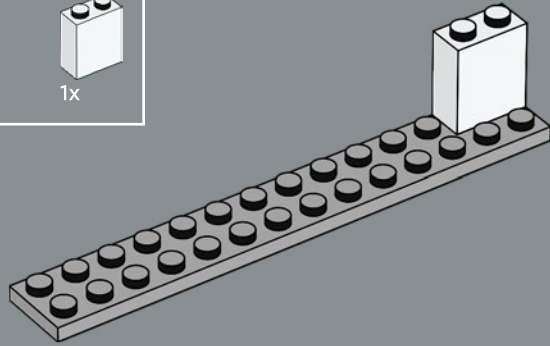

93

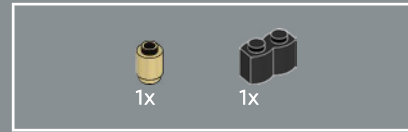
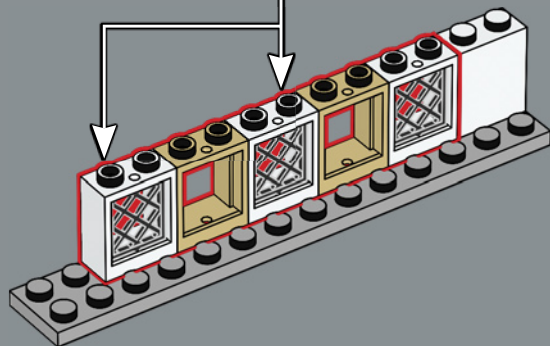
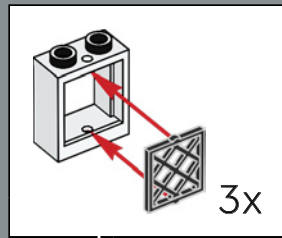

94

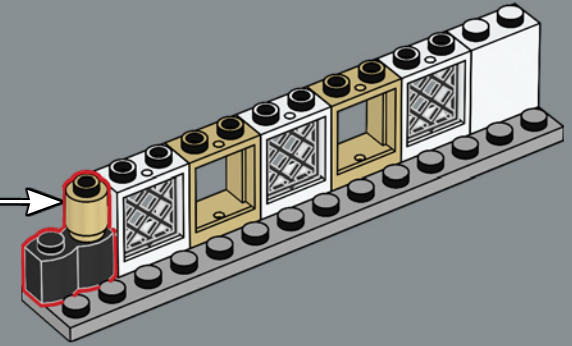
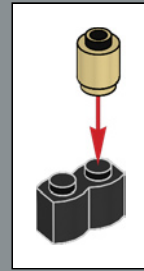

95

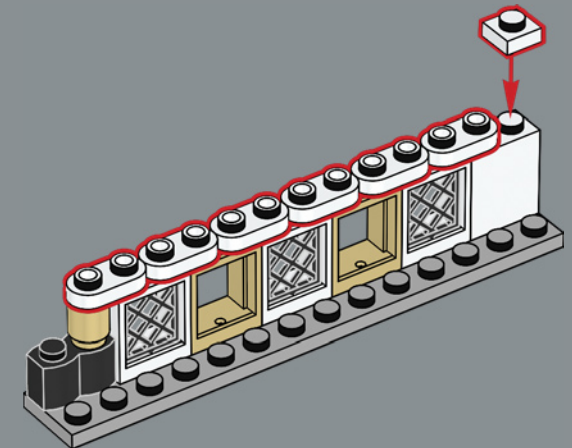

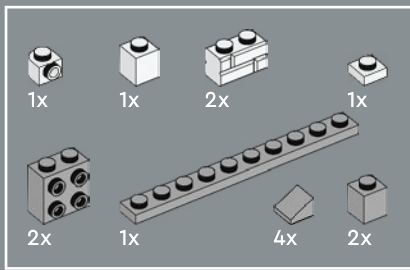

96

Derrière ces fenêtres passent les canalisations d'eau des aqueducs qui se déversent dans la cascade.

1

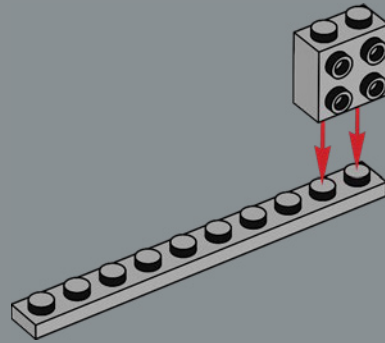

2

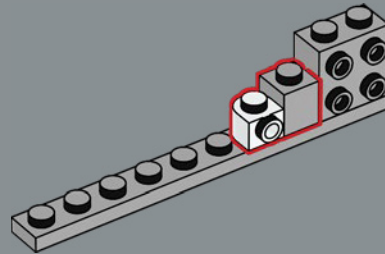

3

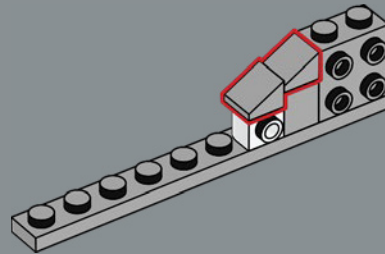

4

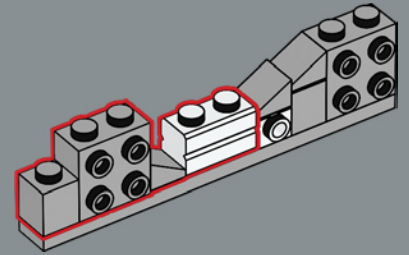

5

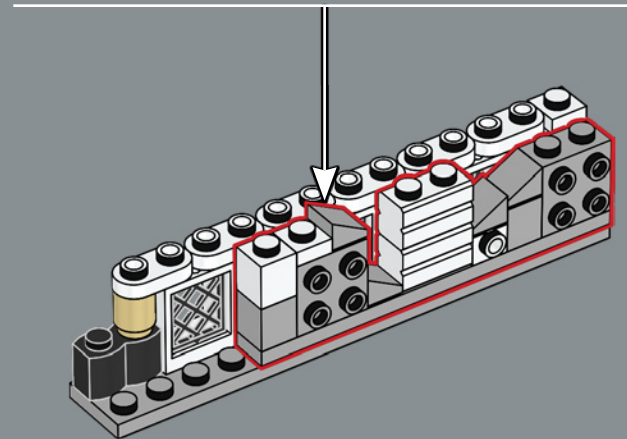
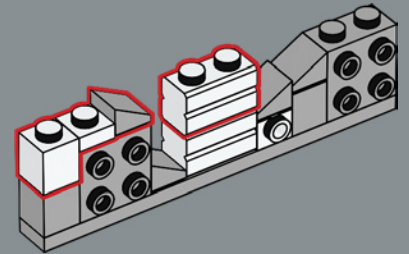

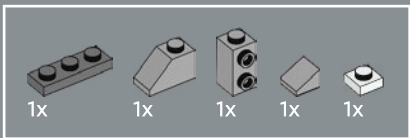

97

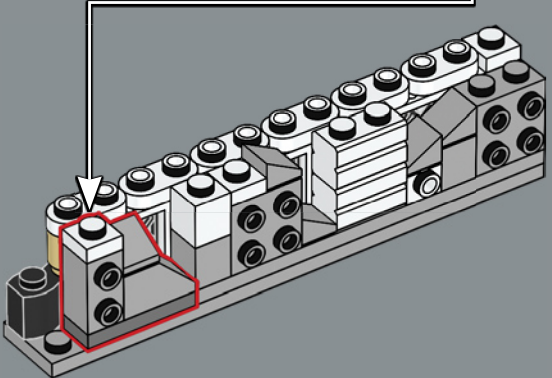
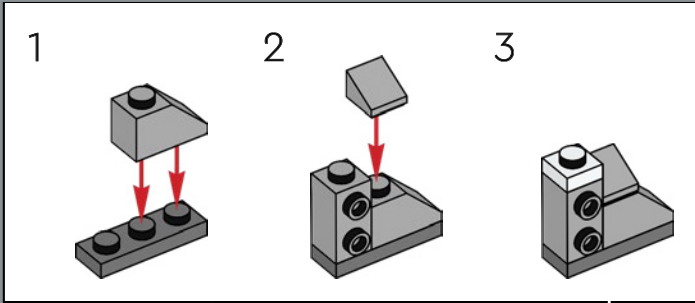

98

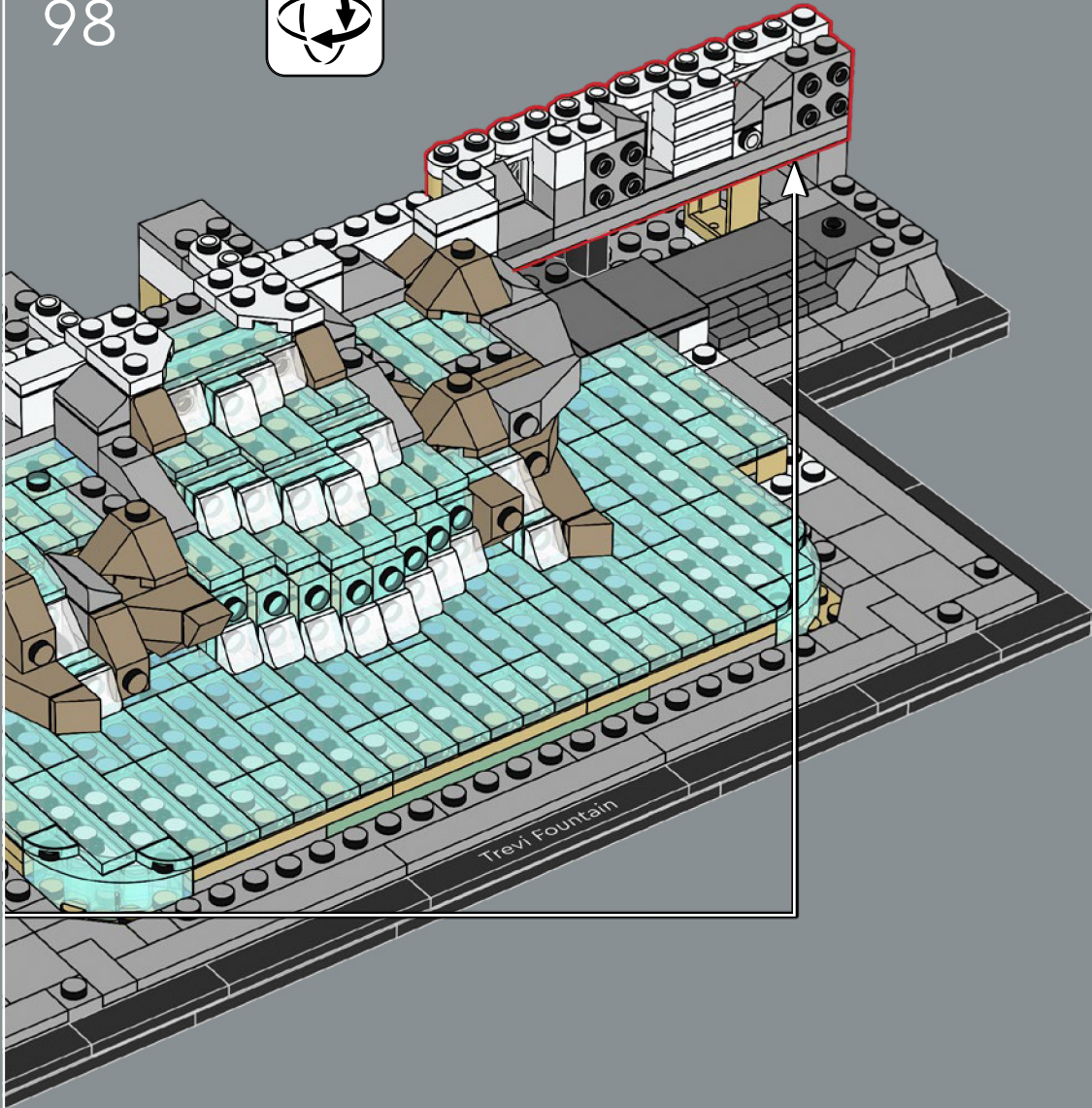

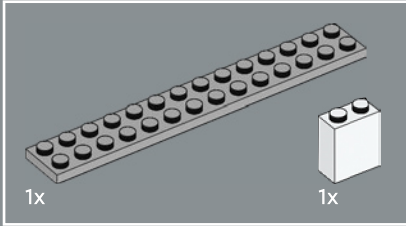
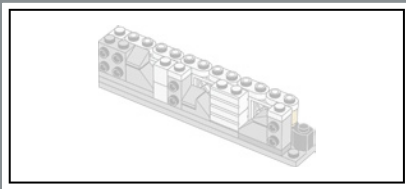

99

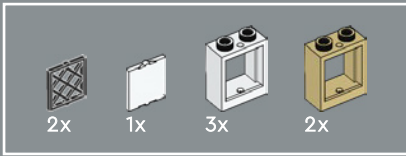
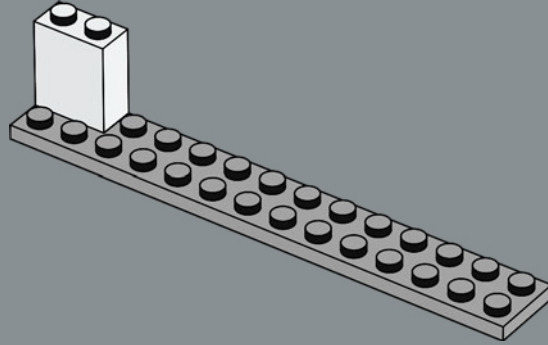

100

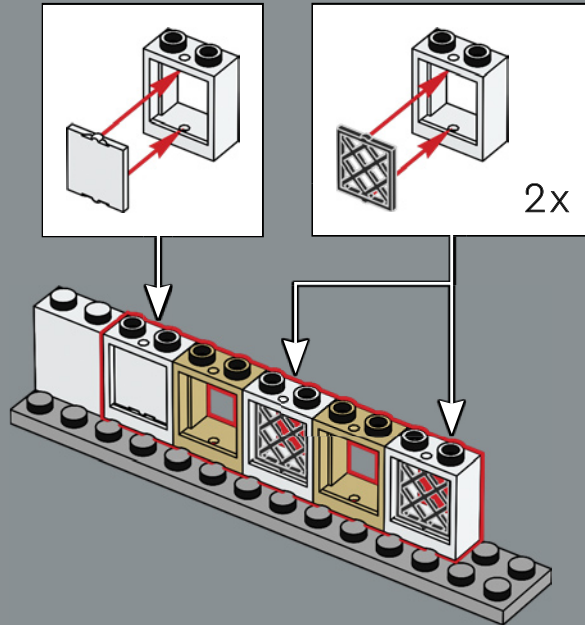

101

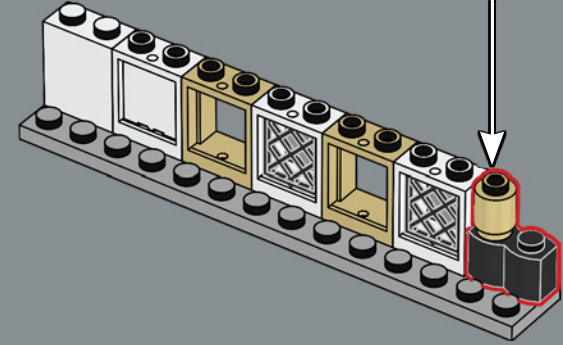
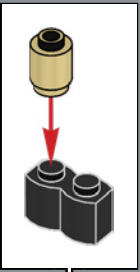

102

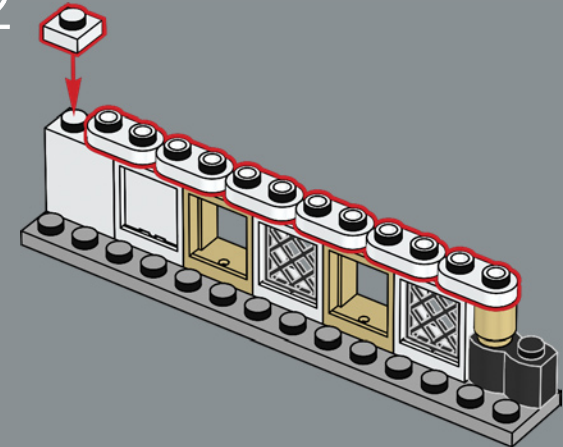

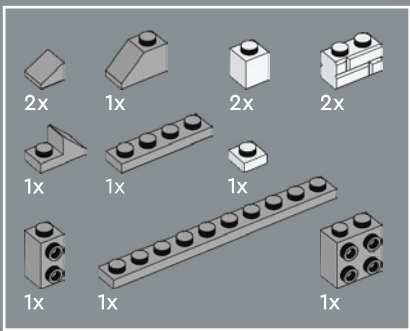

103

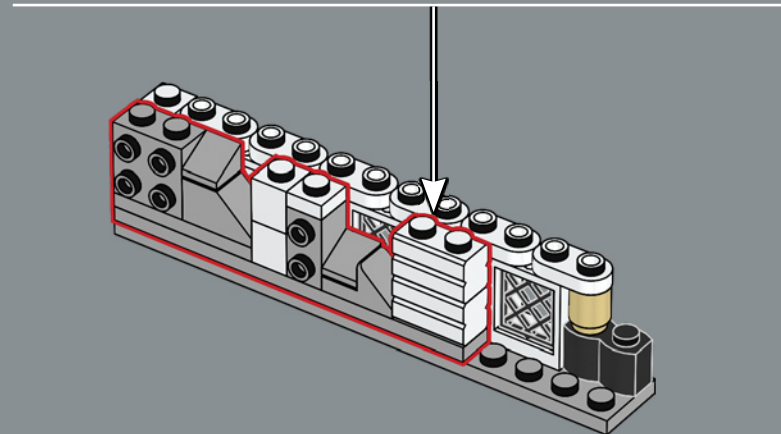
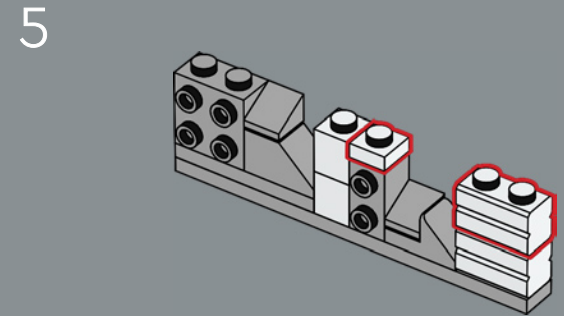
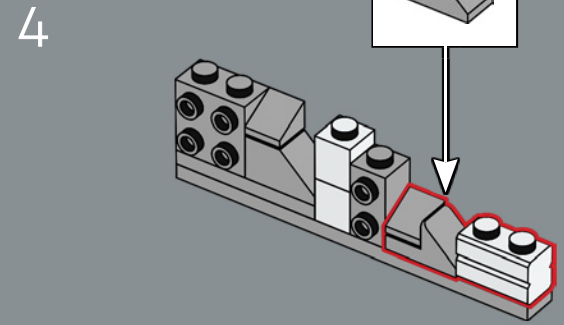
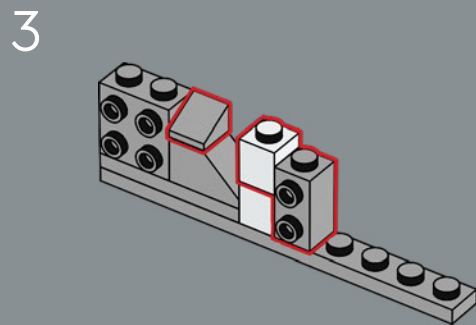
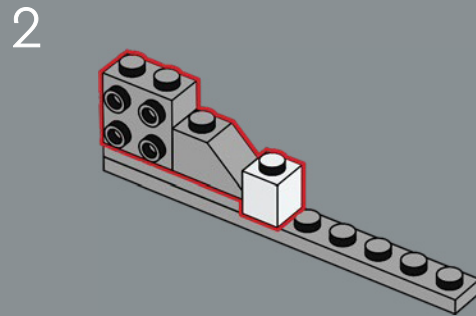
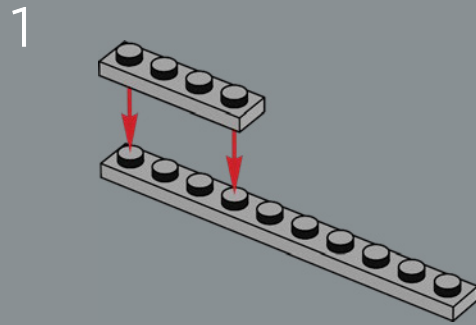

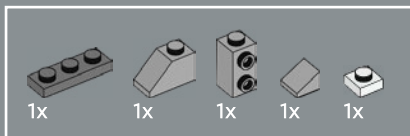

104

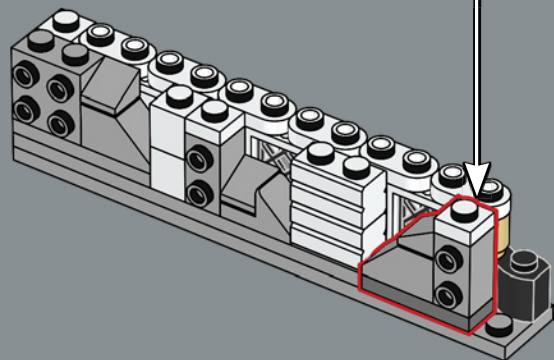
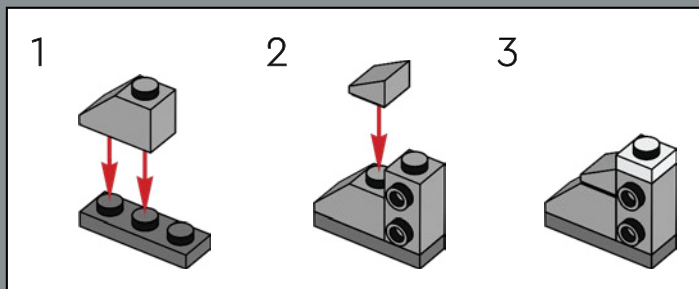

105

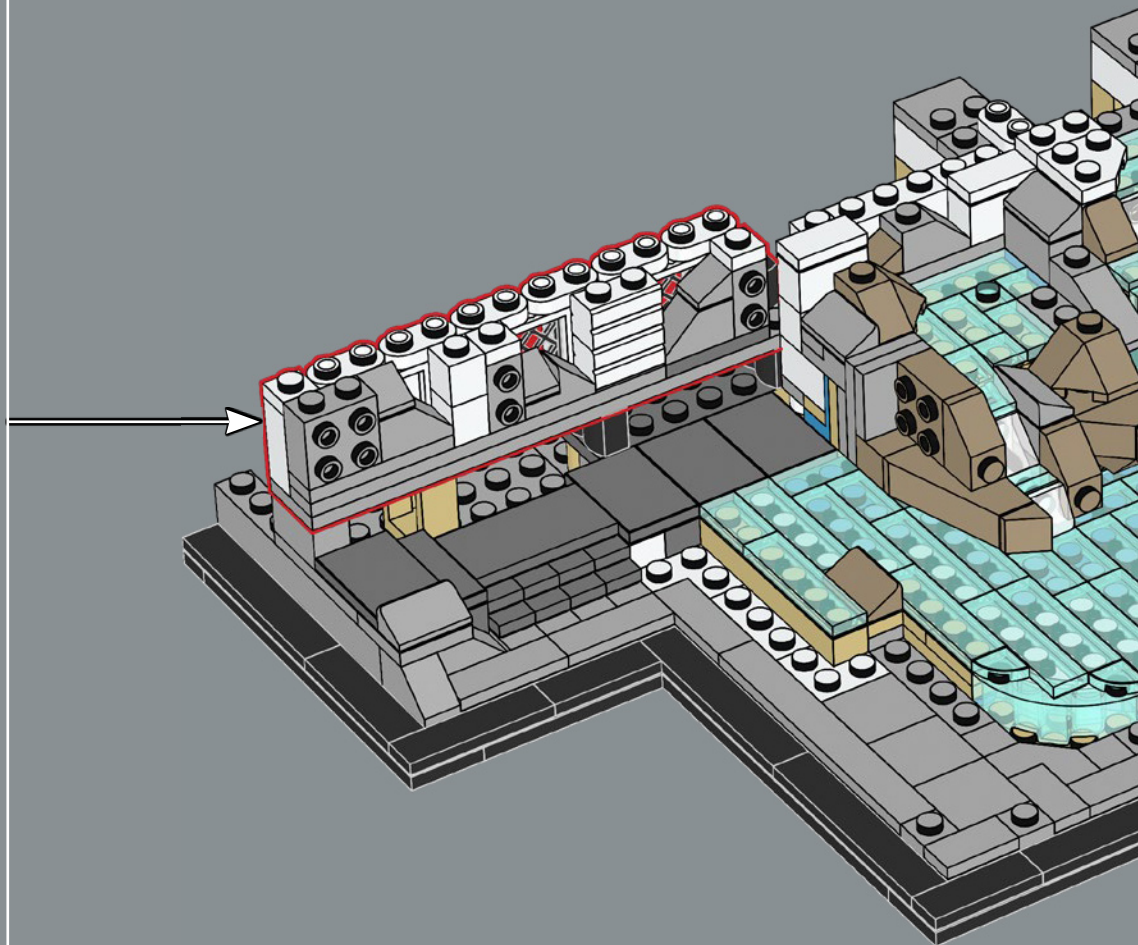

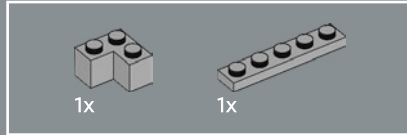
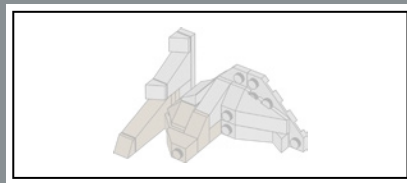

106

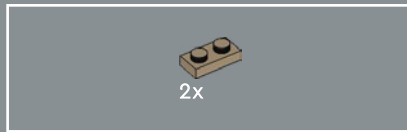
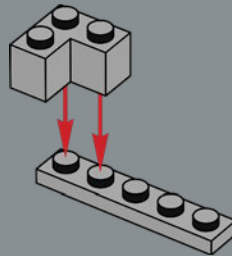

107

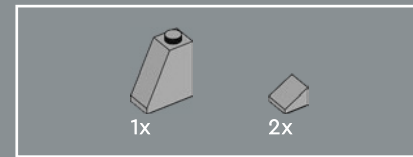
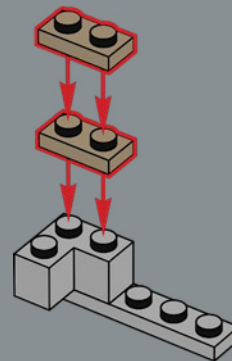

108

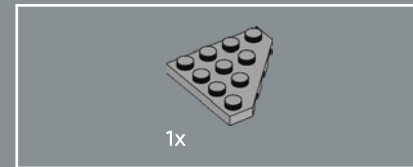
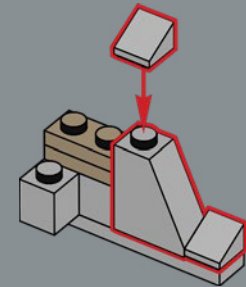

109

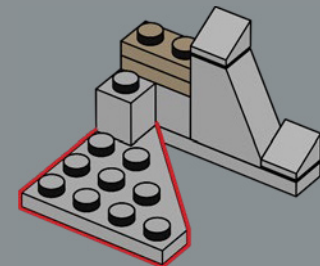

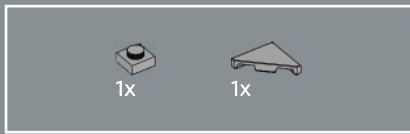

110

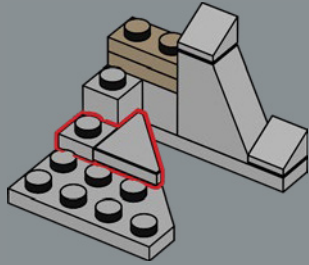

112

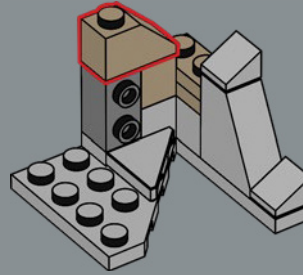

114

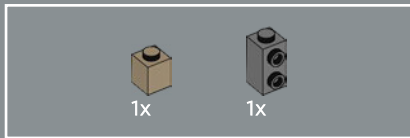
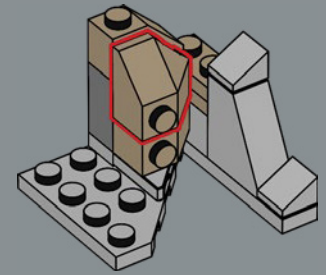

111

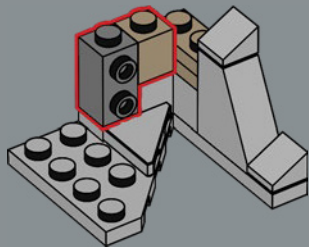

113

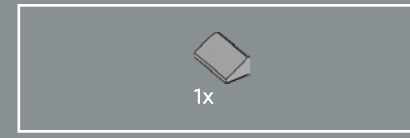
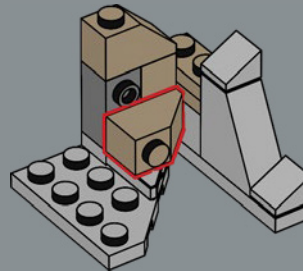

115

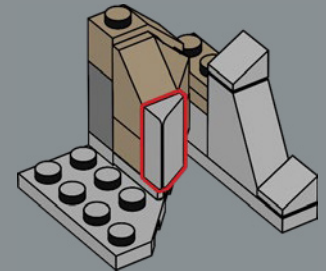

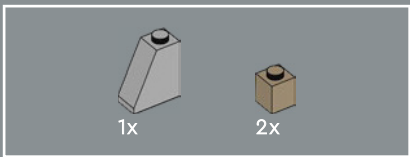

116

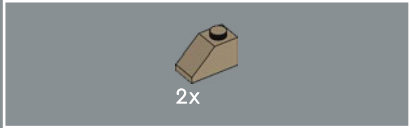
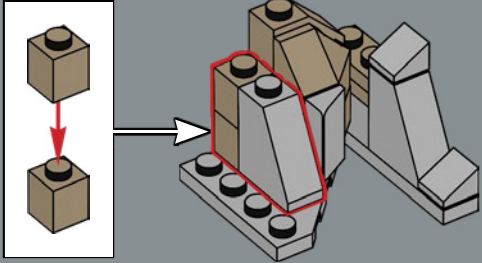

117

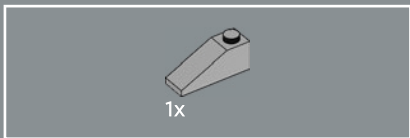
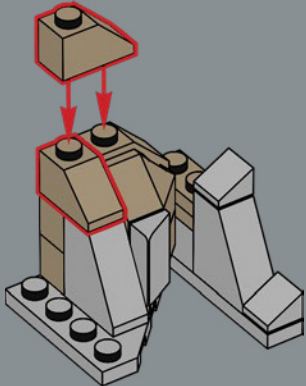

118

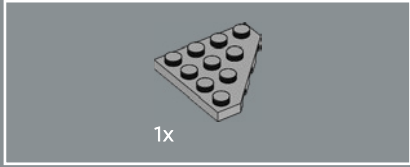
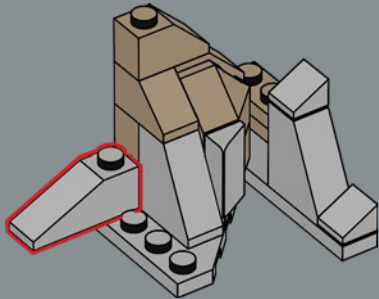

119

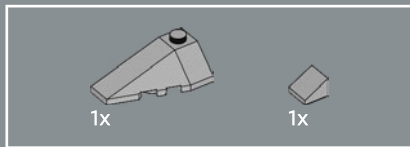
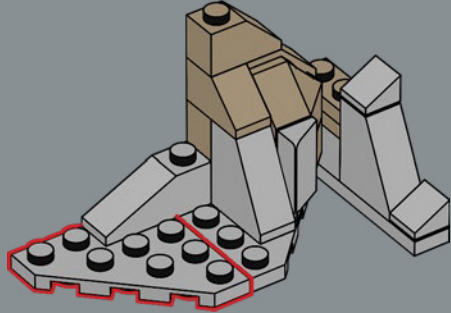

120

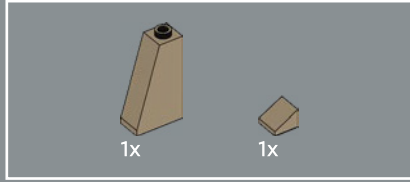
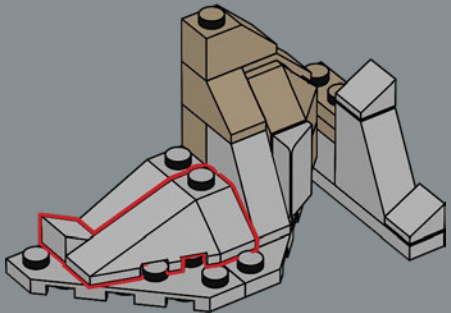

121

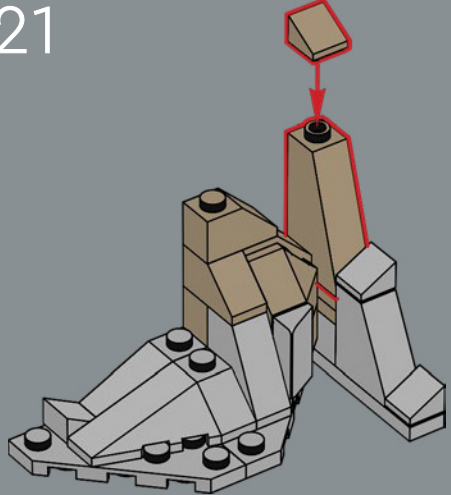

122

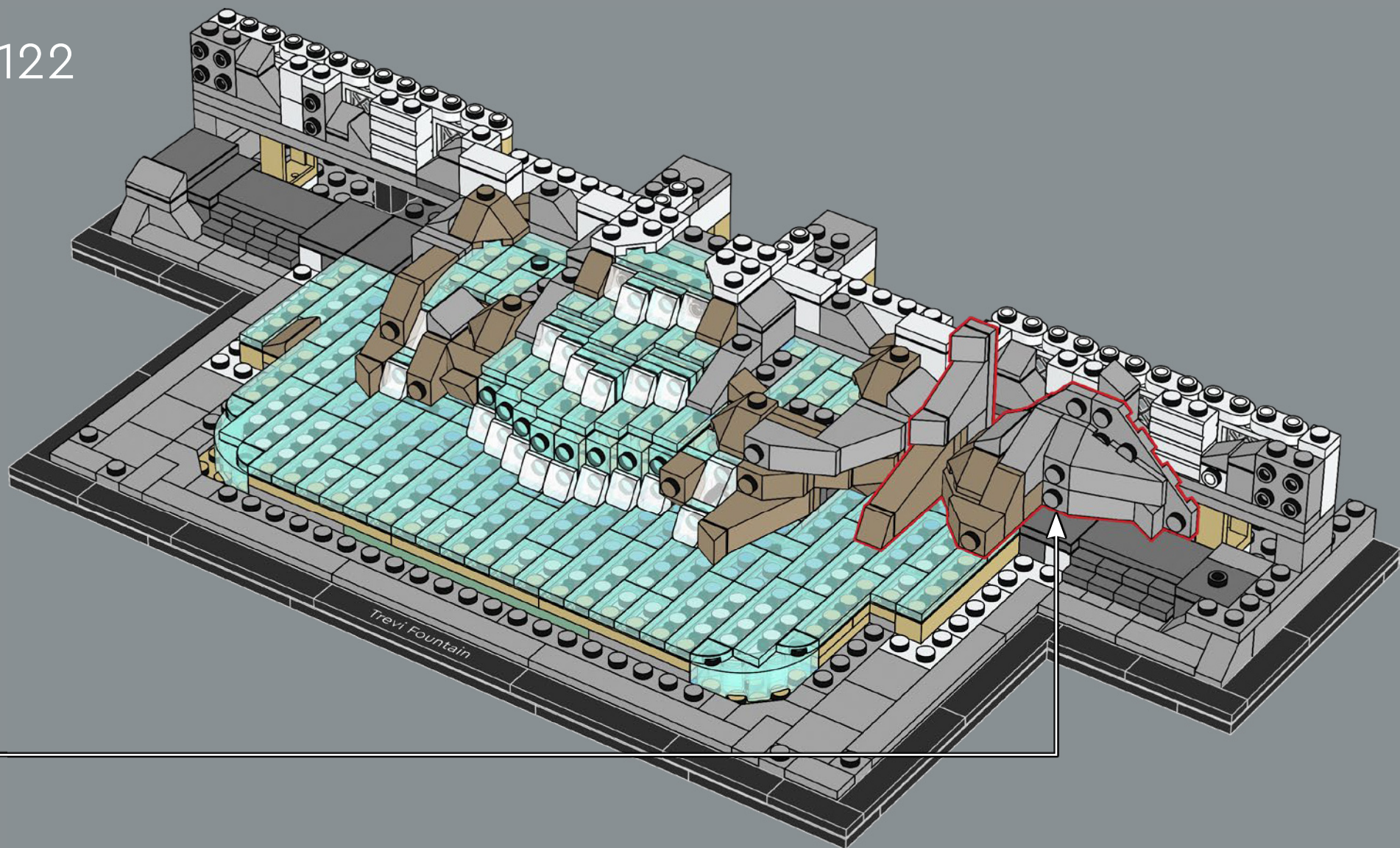

La roche est l'un des rares détails qui perturbe la symétrie globale du monument baroque, tout en ajoutant un contraste saisissant par rapport au reste de la façade ornée de formes organiques.

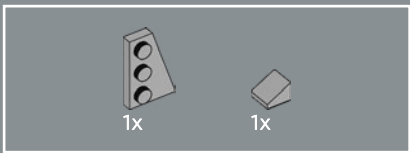

123

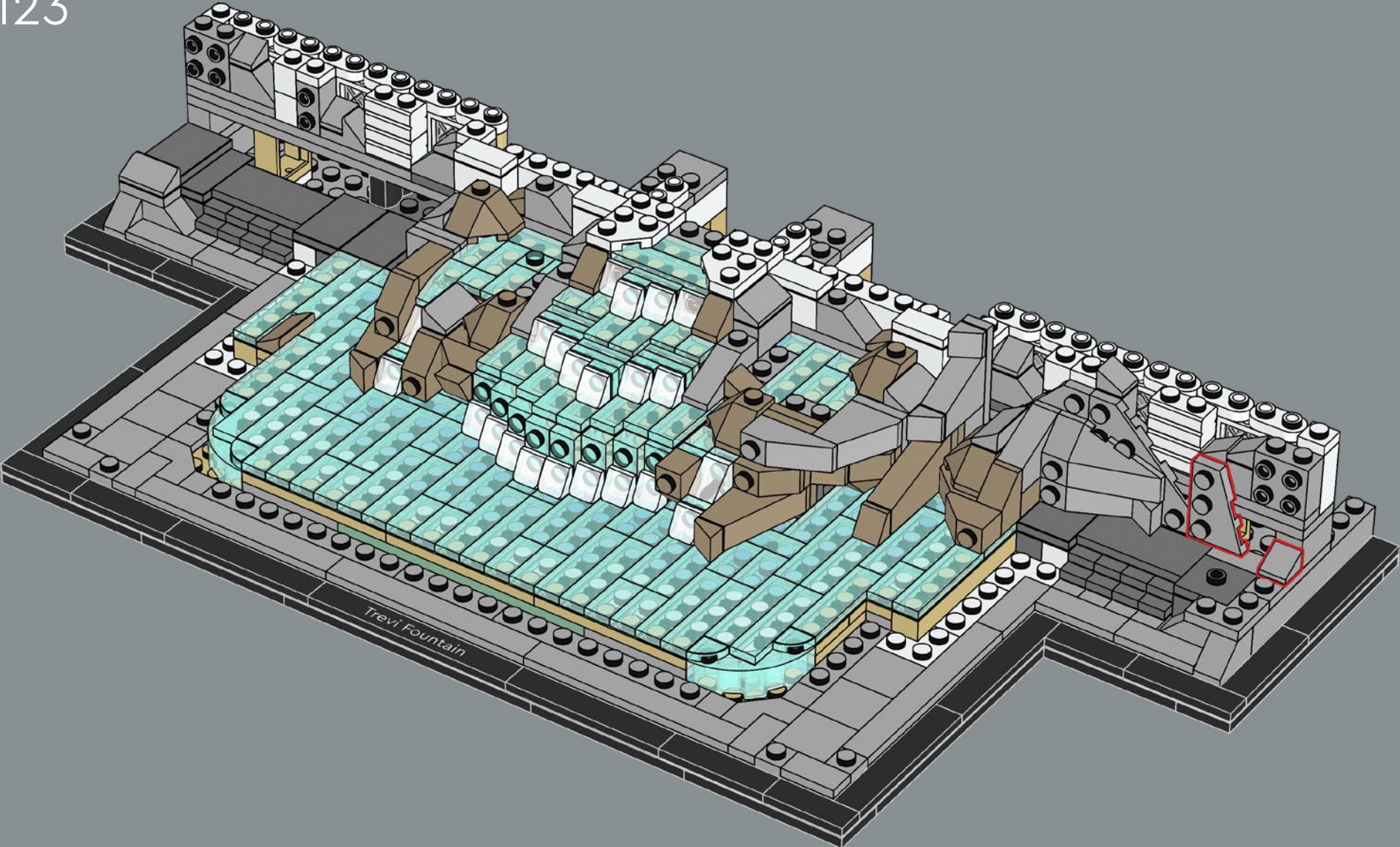

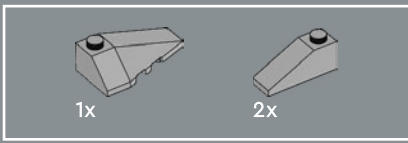

124

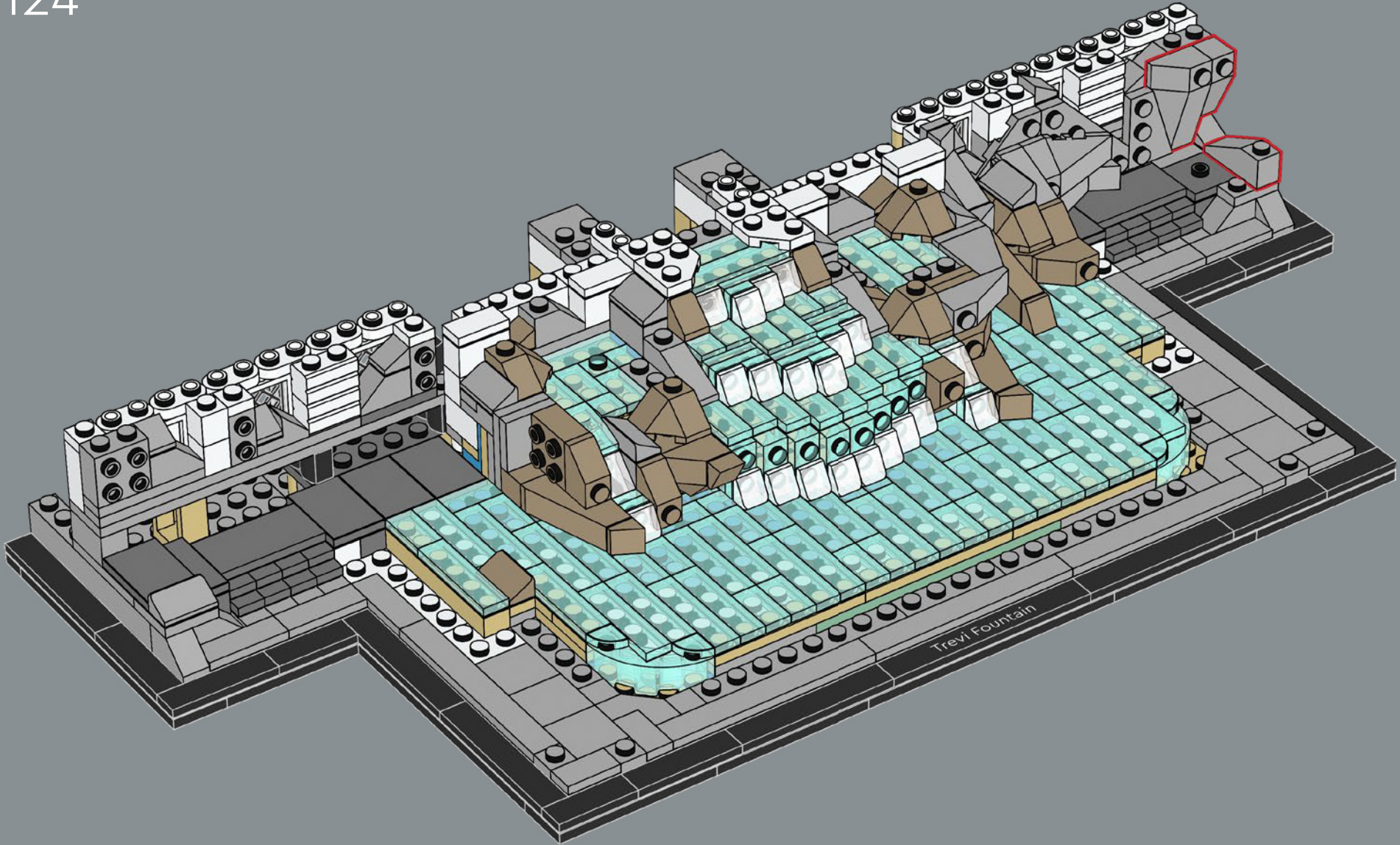

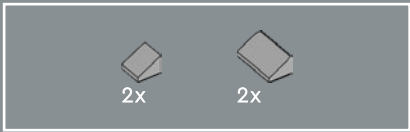

125

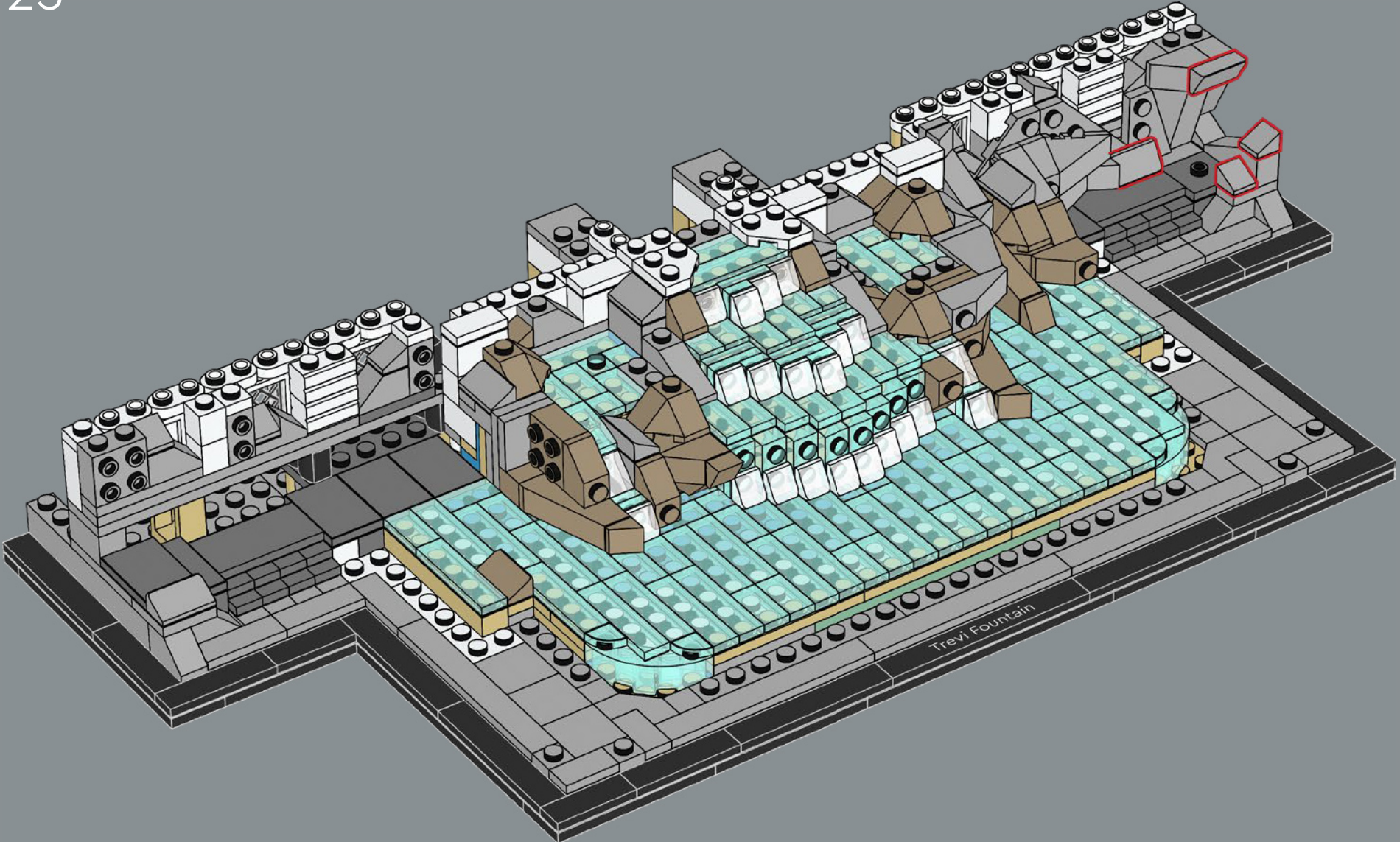

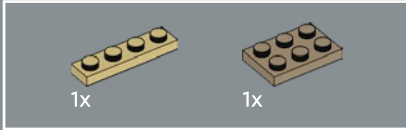
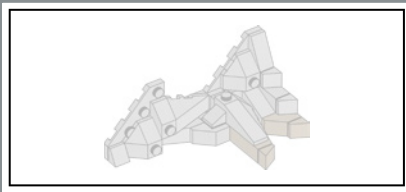

126

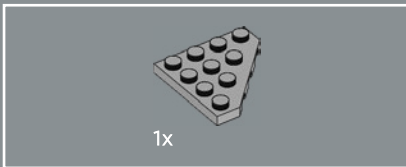
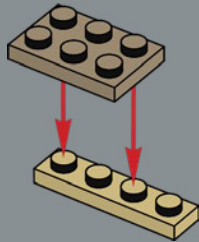

127

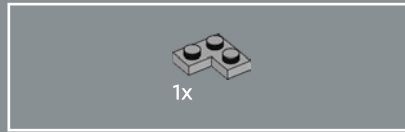
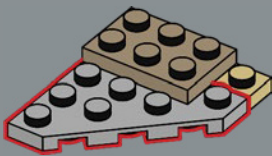

128

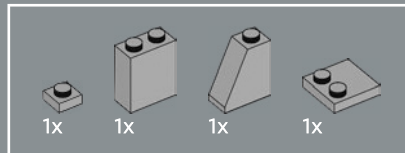
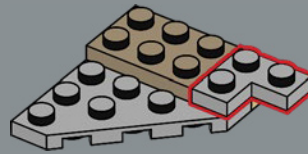

129

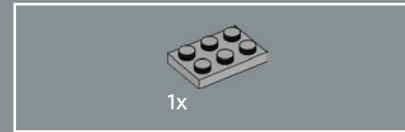
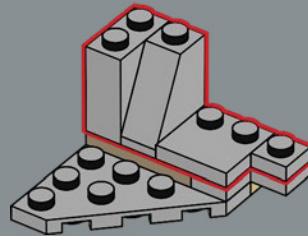

130

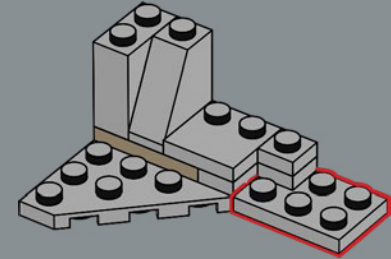

131

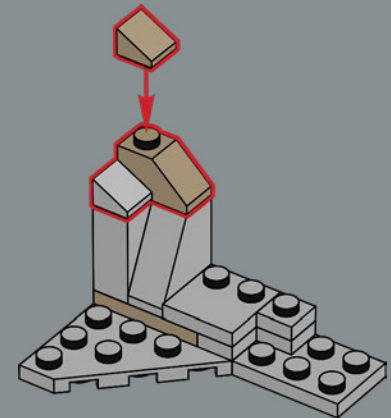



132

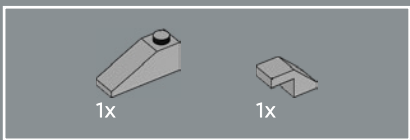
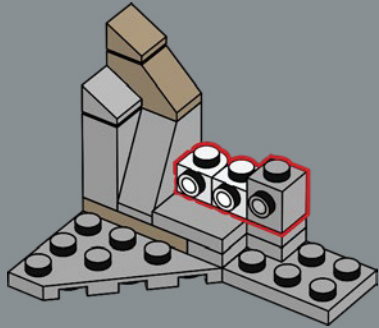

133

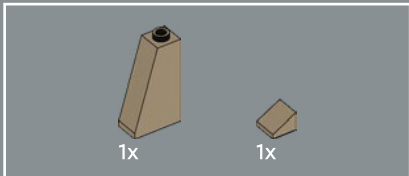
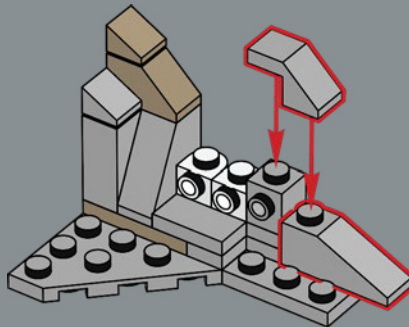

134

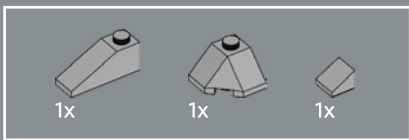
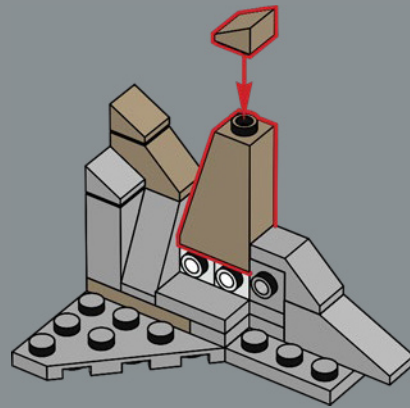

135

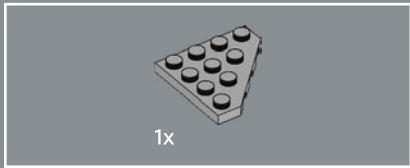
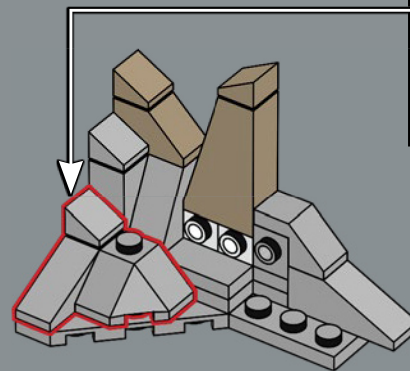

136

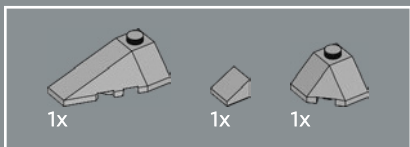
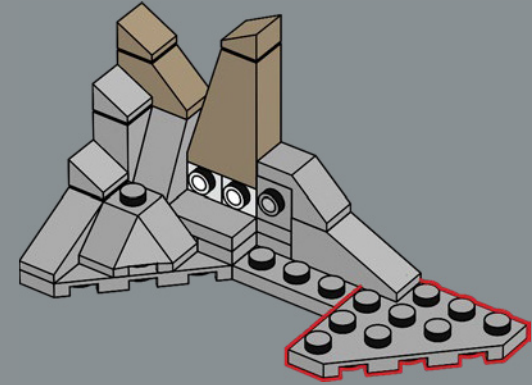

137

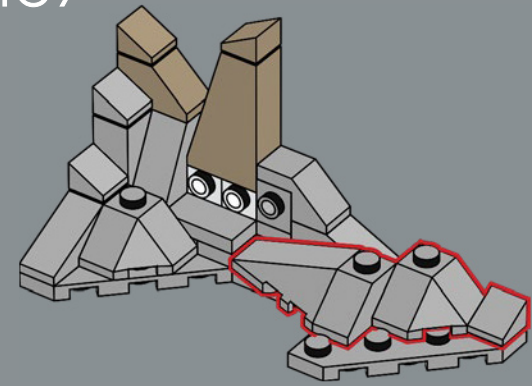

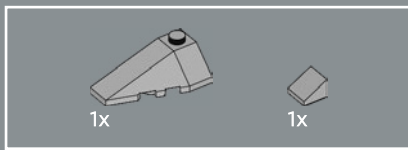

138

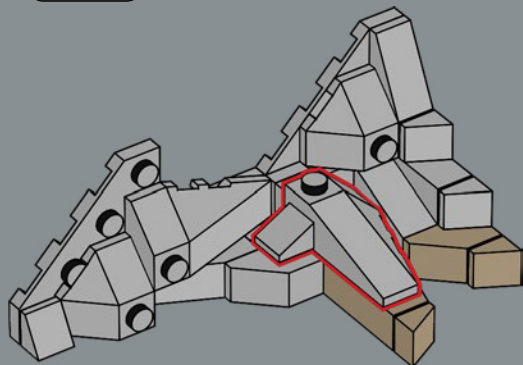

Même l'usure de la fontaine joue un rôle dans la façon dont elle est représentée. L'usure due aux éléments naturels s'accumule dans les moindres recoins de la surface sculptée; rendant les zones gravées, même les moins profondes, plus sombres que la roche environnante.

139

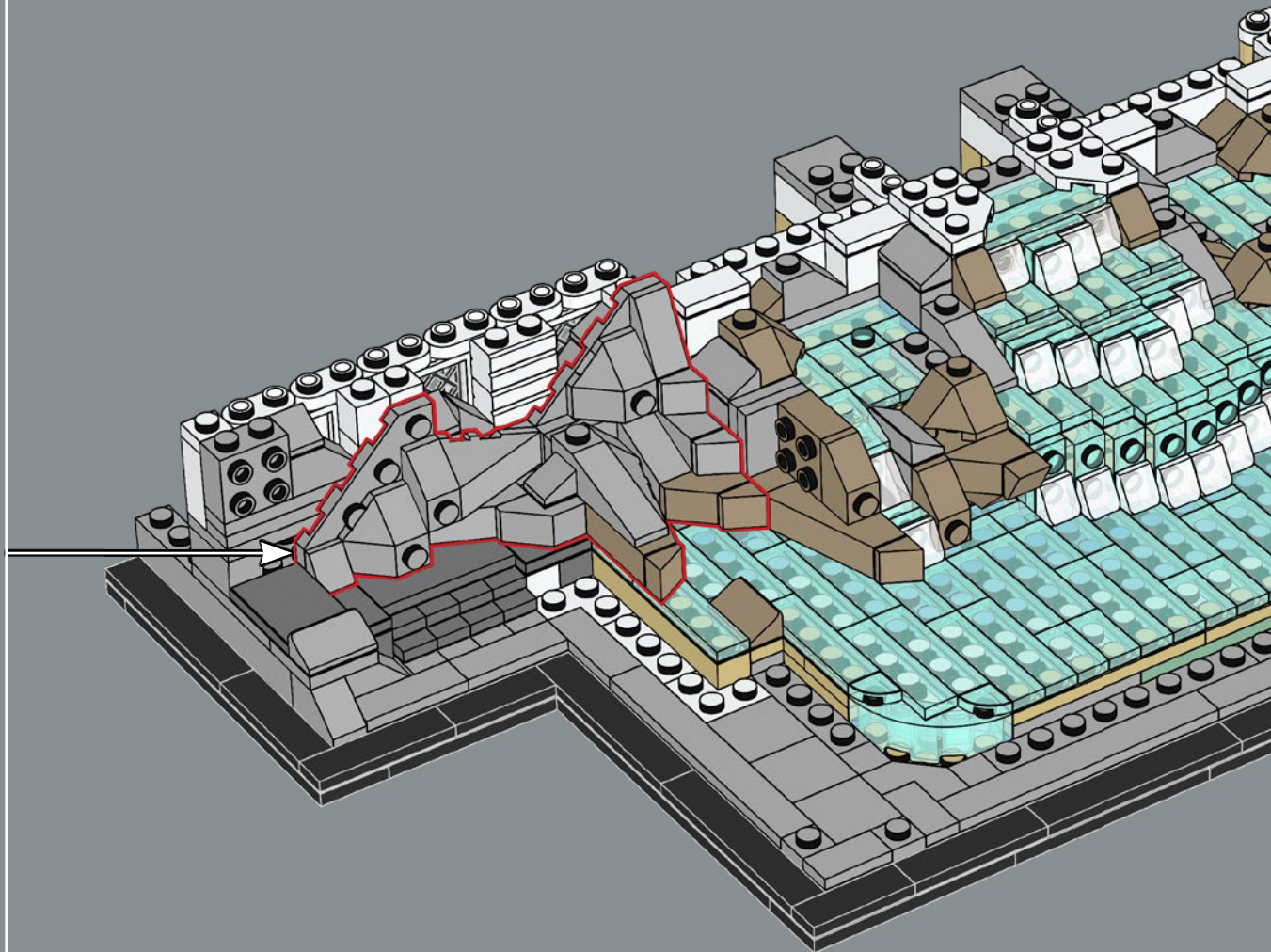

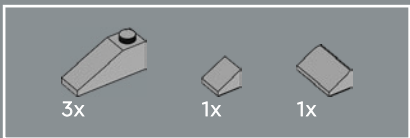

140

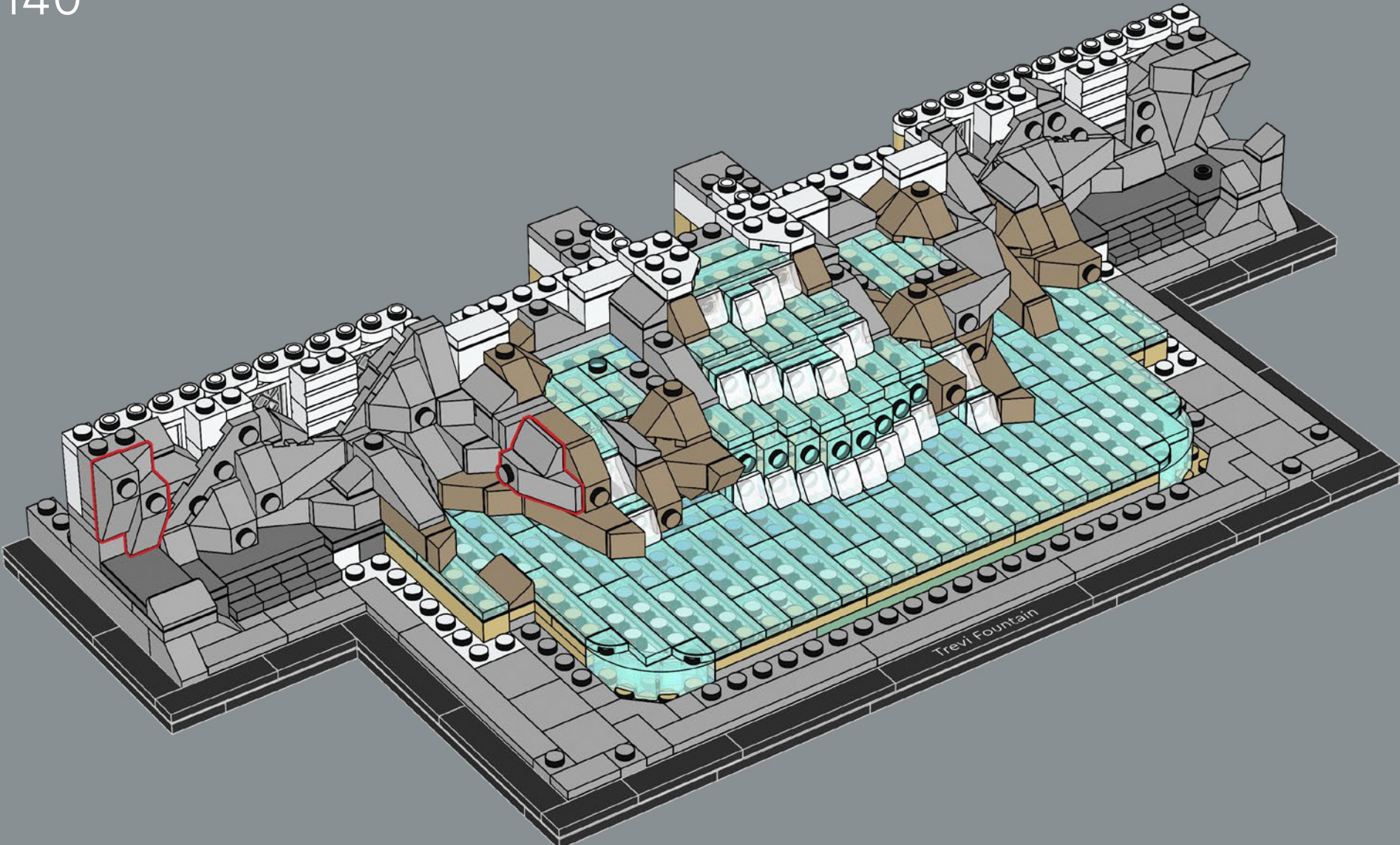

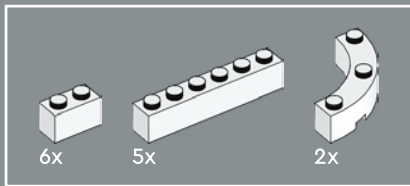

141

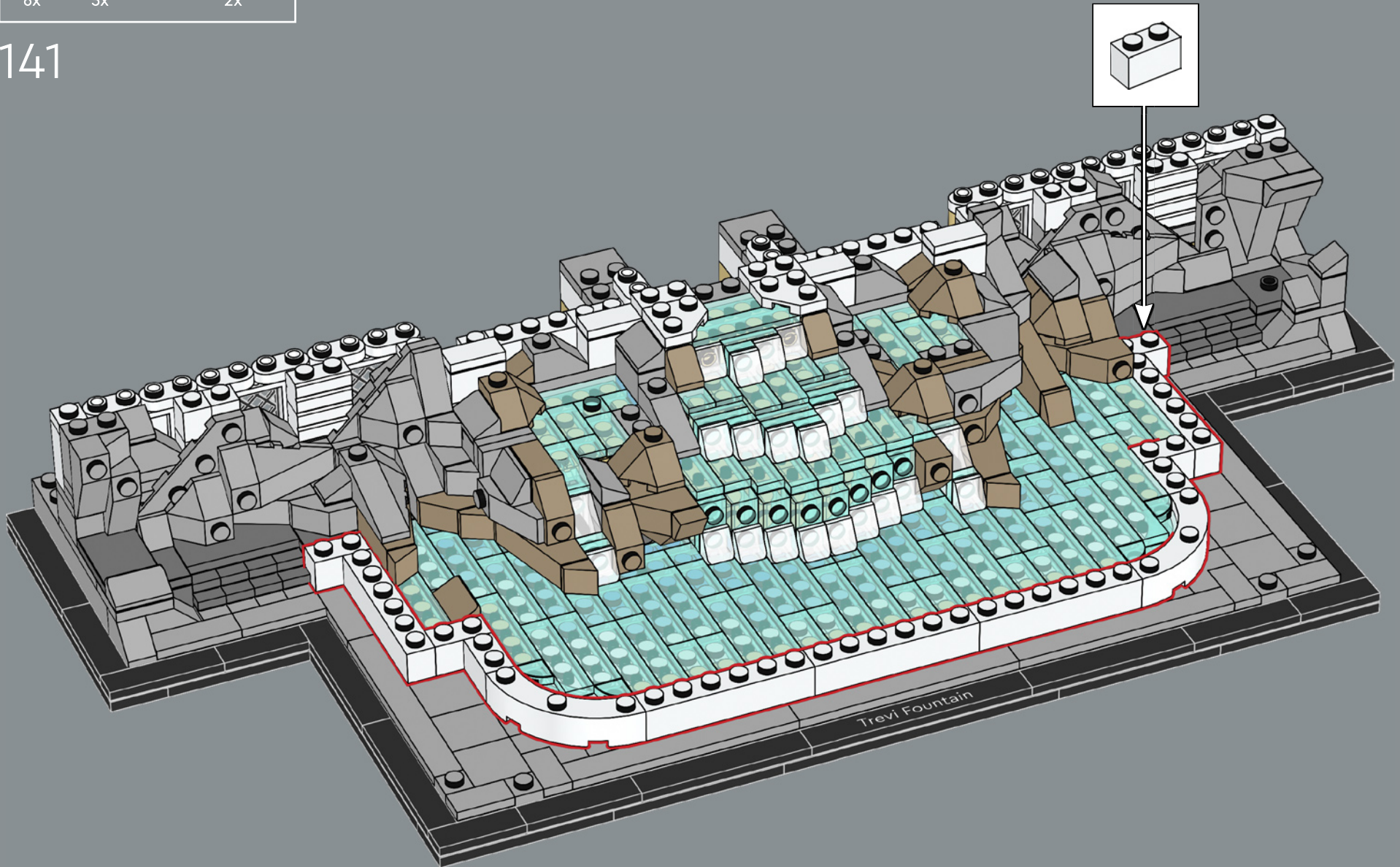

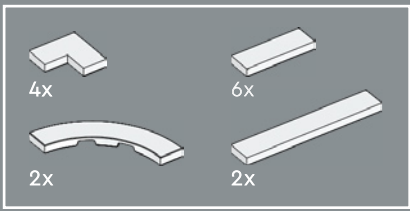

142

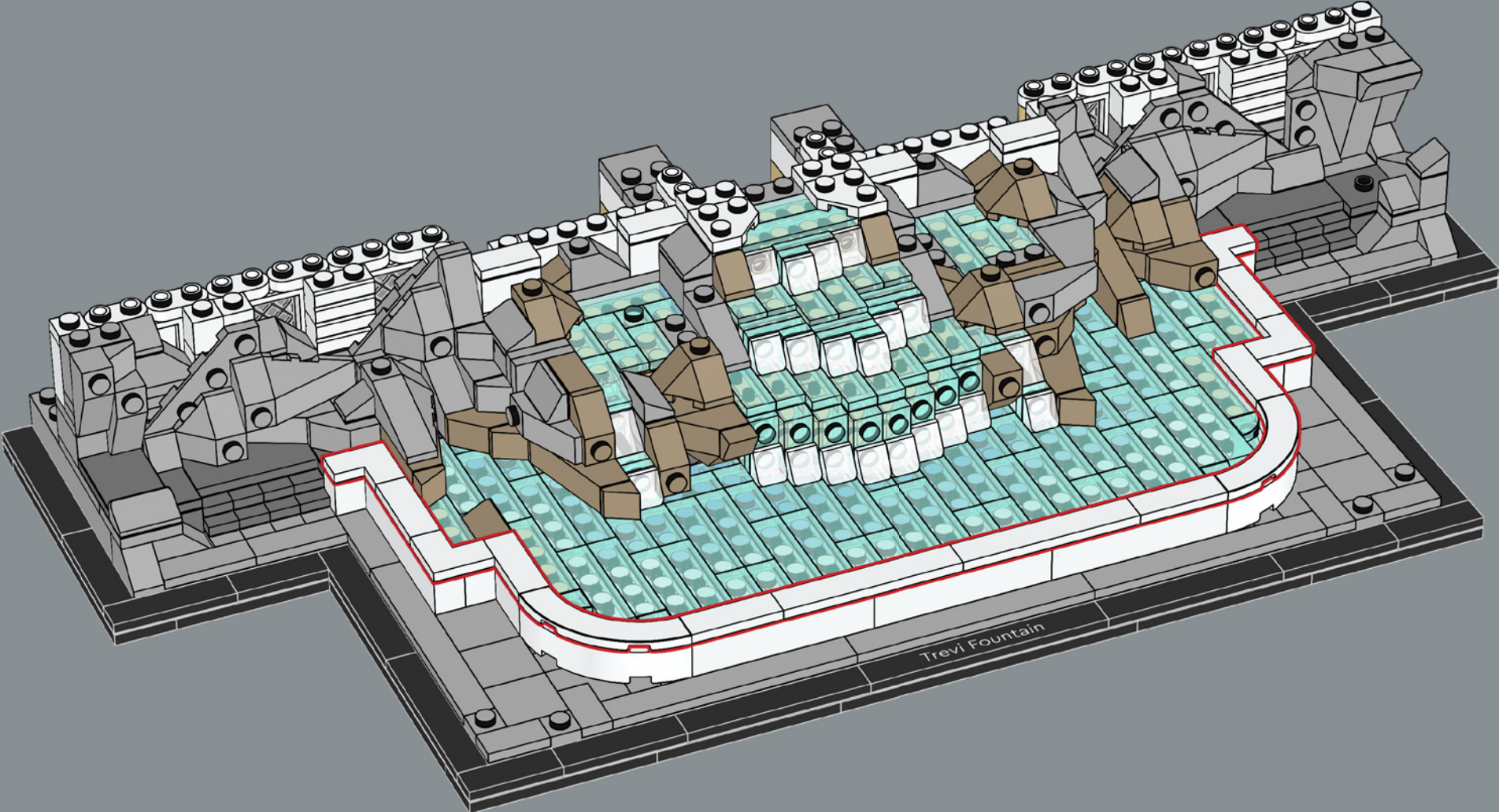

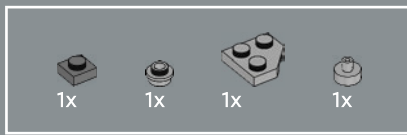

143

Cette petite fontaine est surnommée la Fontanella degli Innamorati (la fontaine des amoureux) en raison de ses jets d'eau qui se croisent. La légende dit que si deux amoureux boivent à cette fontaine, ils resteront unis et fidèles à jamais.

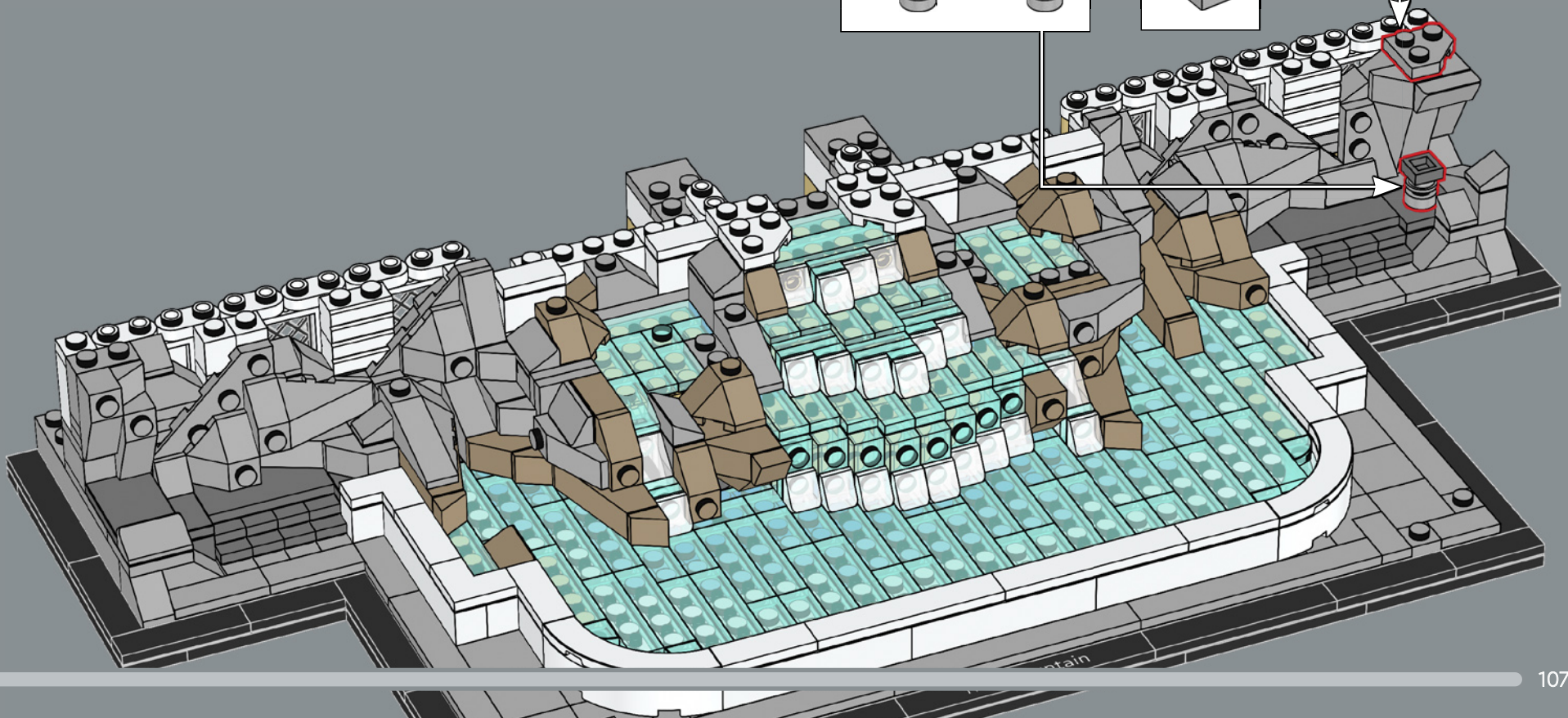
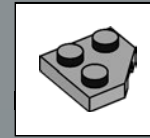
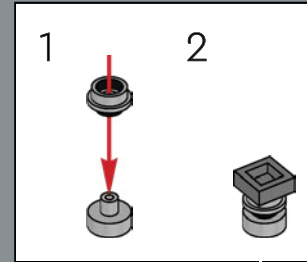

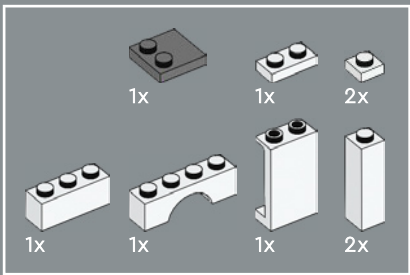

144

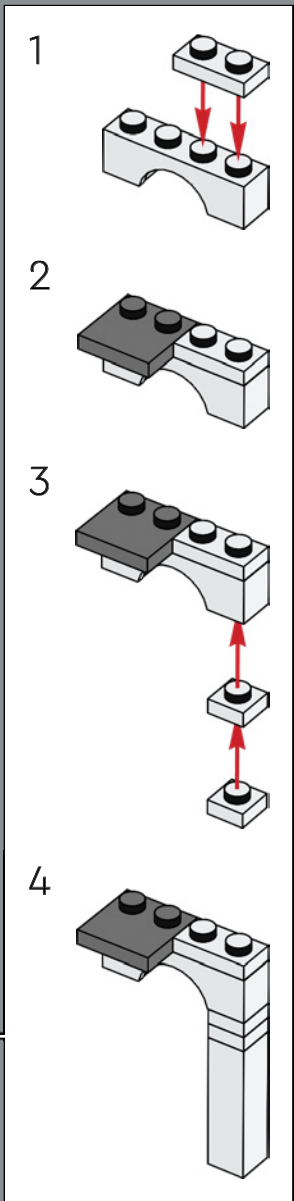
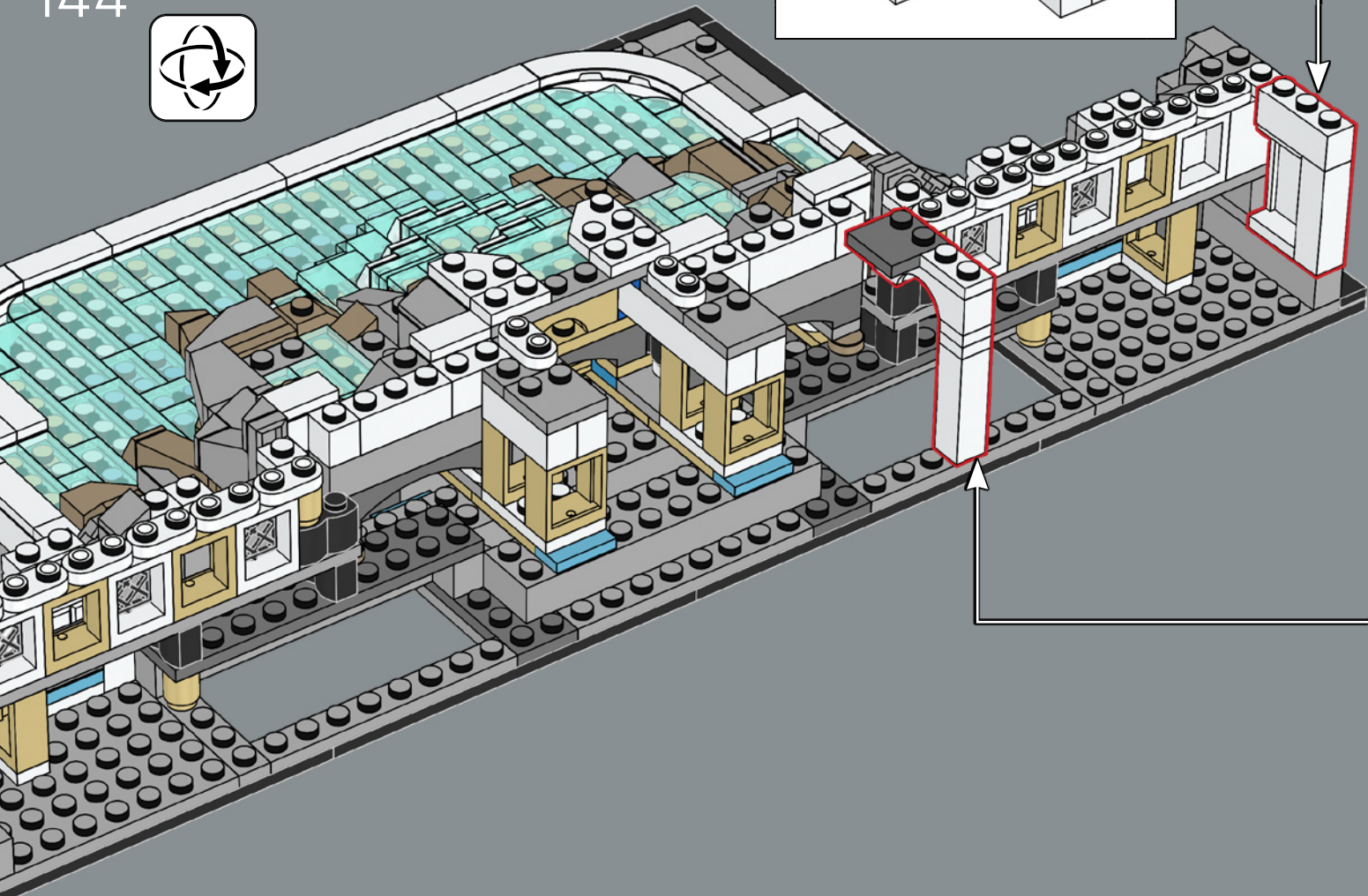
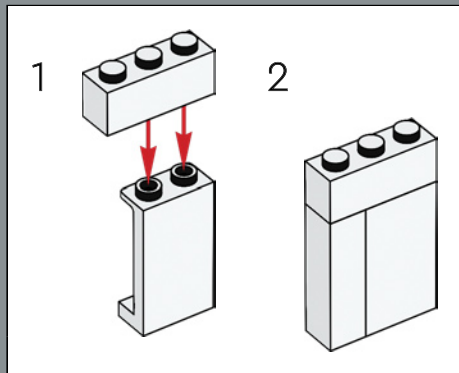

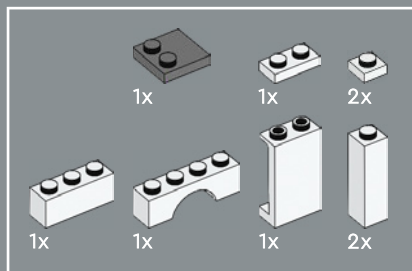

145

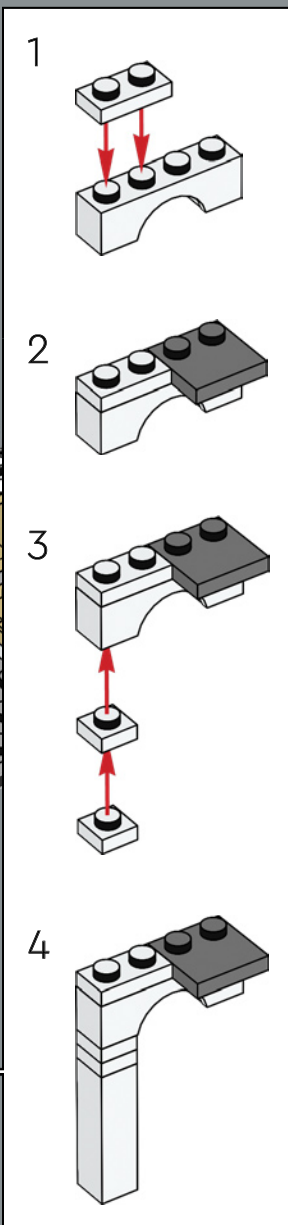
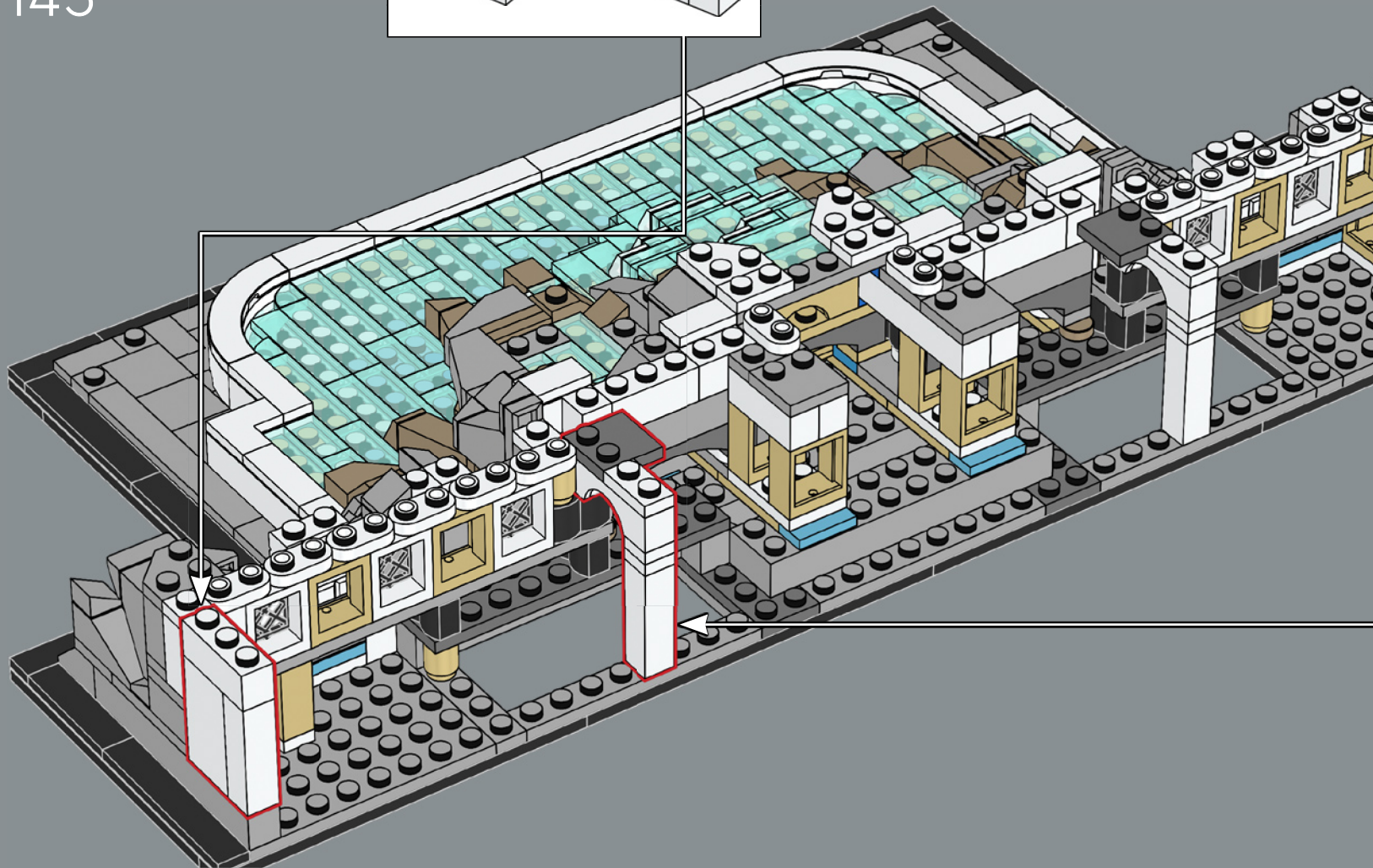
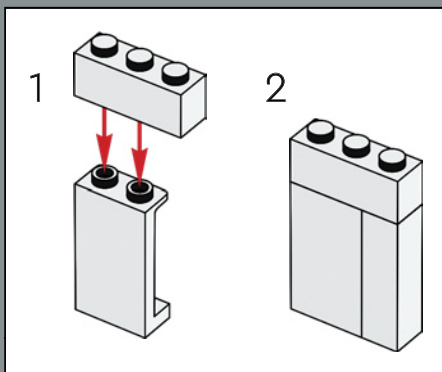

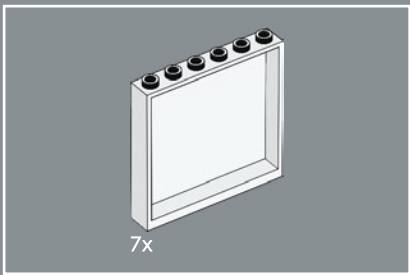

146

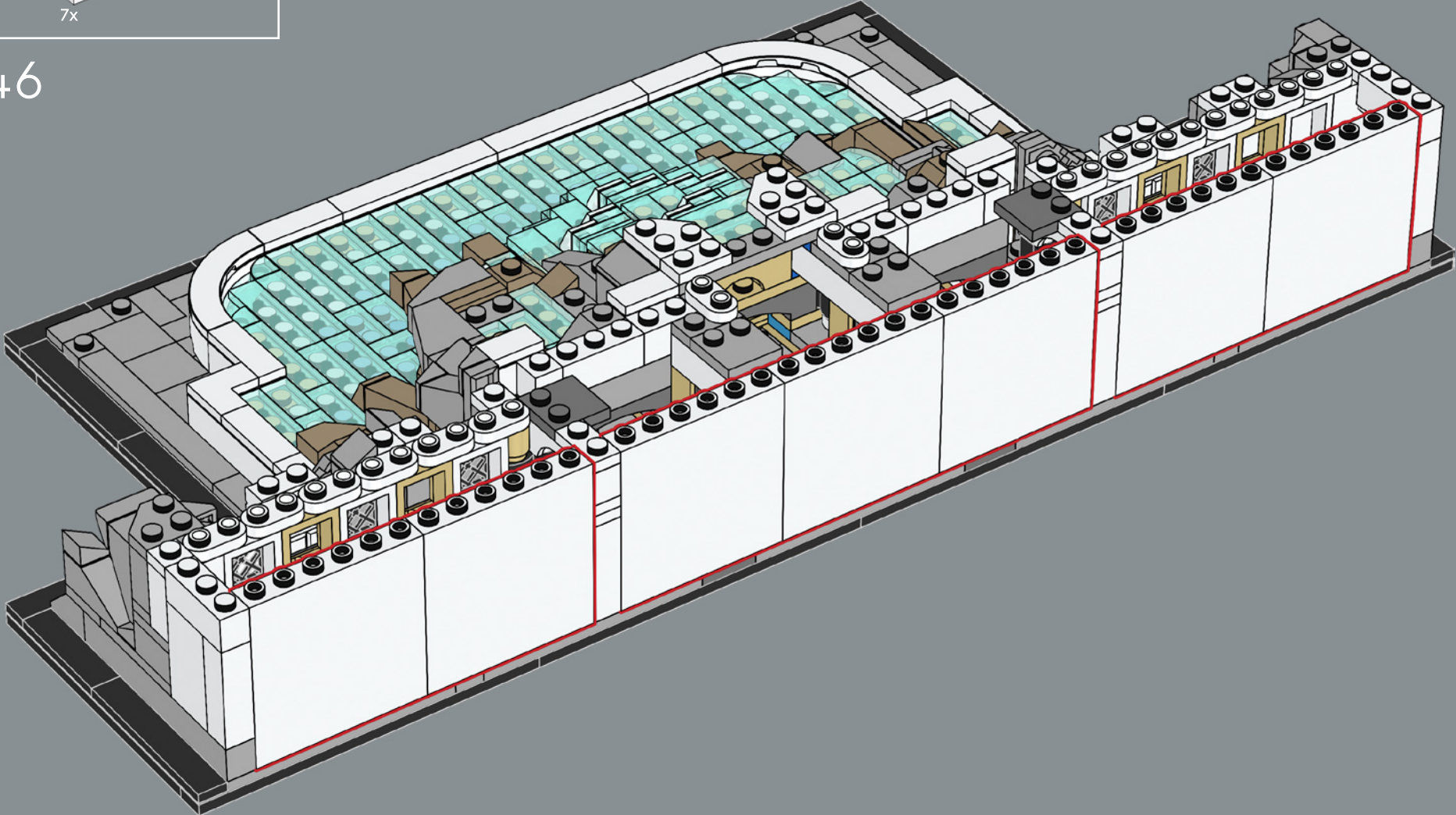

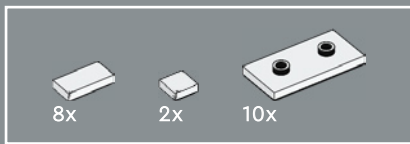

147

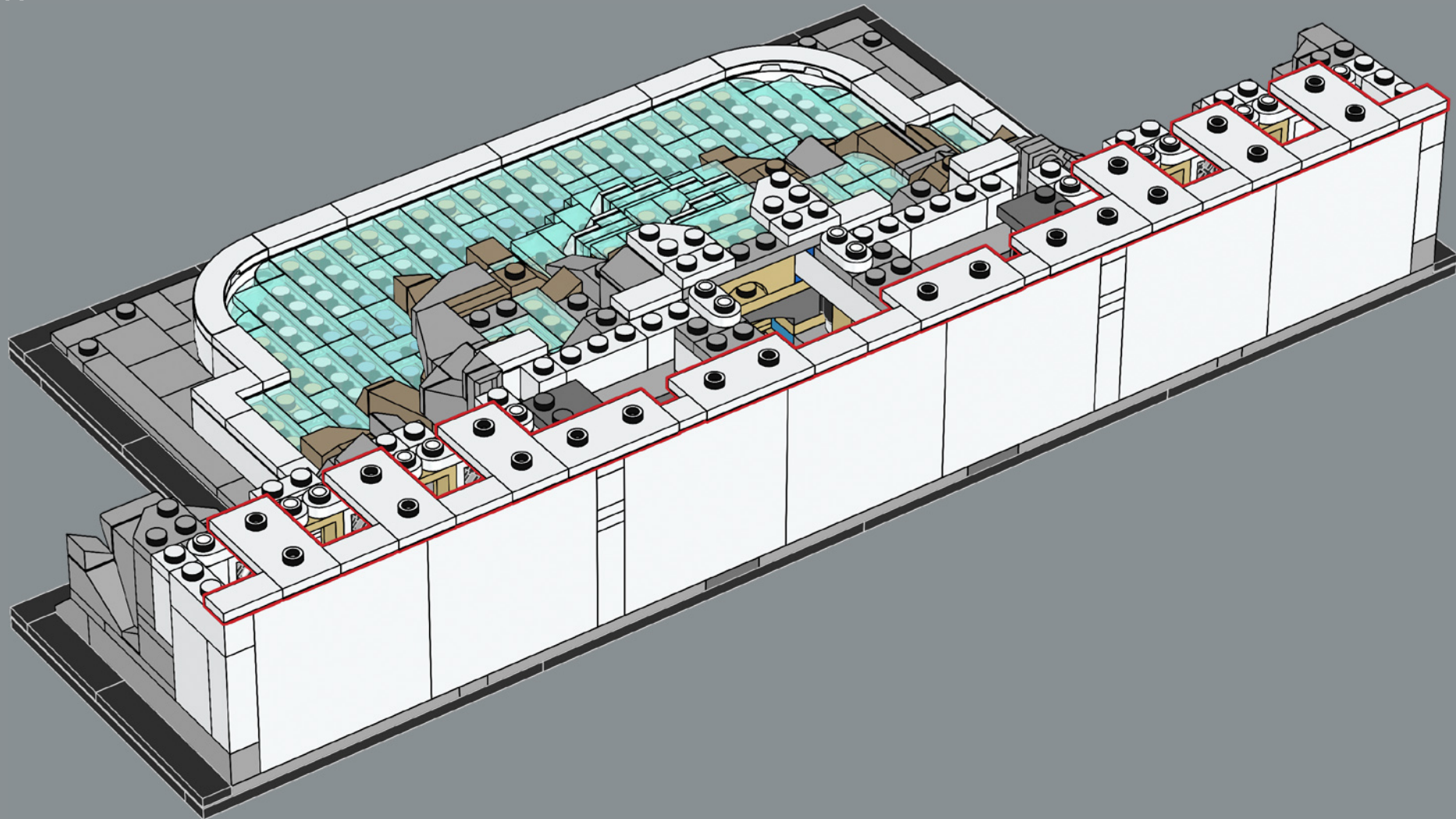

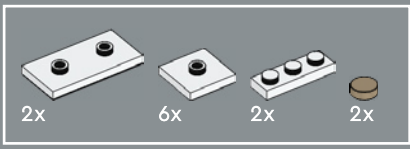

148

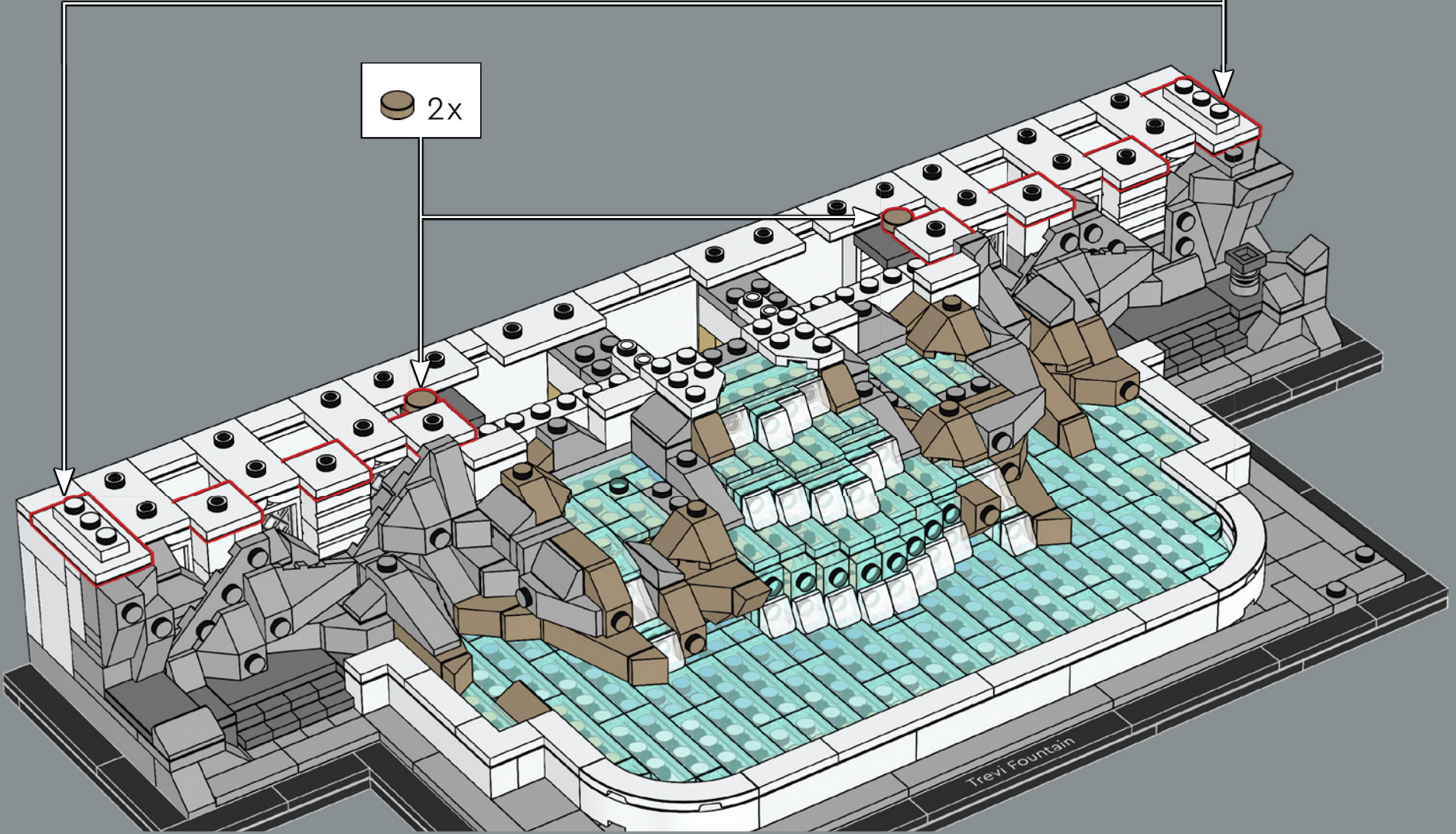
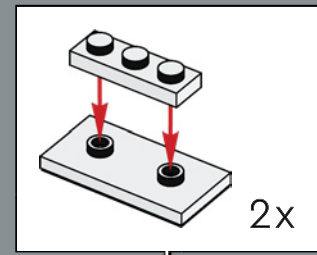

Trevi Fountain

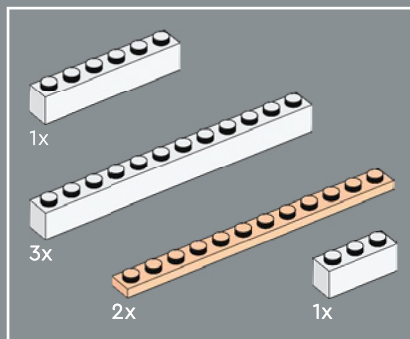

Pour recréer fidèlement les détails et espacements dans les surplombs et les parties décalées de la façade, nous avons alterné l'alignement LEGO® standard et des 1/2 plaques qui dépassent. Cela assure un processus de construction fluide ainsi que la solidité du modèle.

149

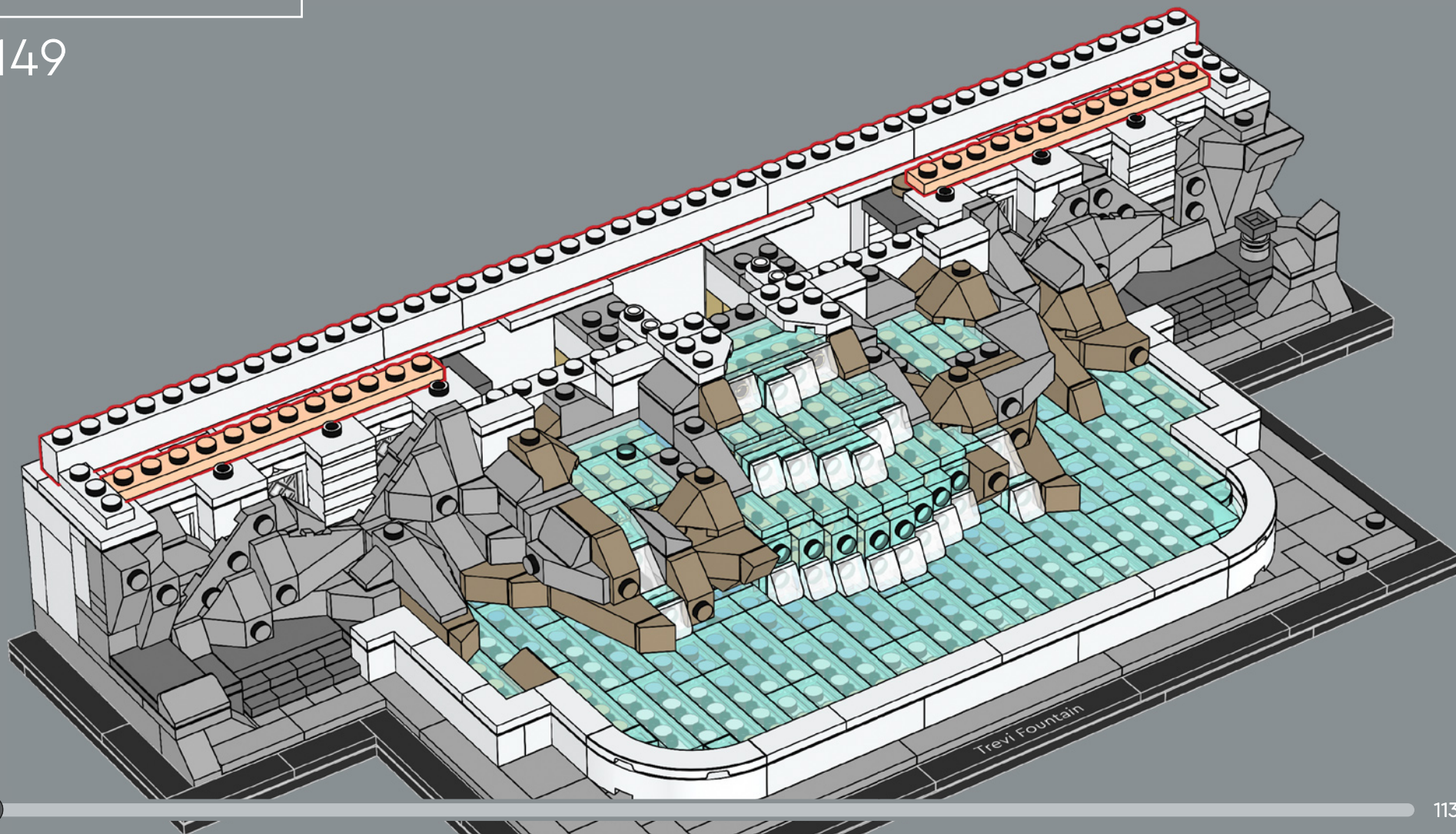



6x

150



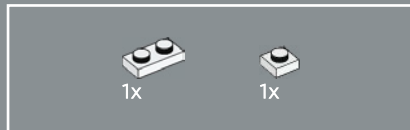
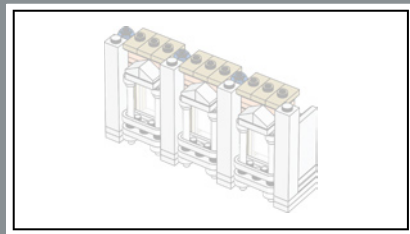

151

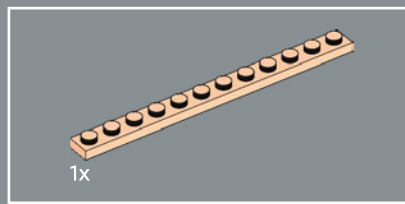
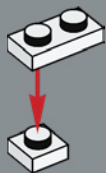

152

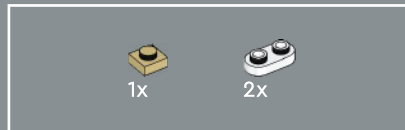
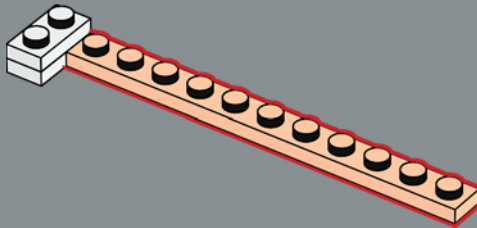

153

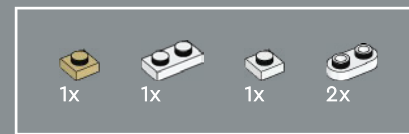
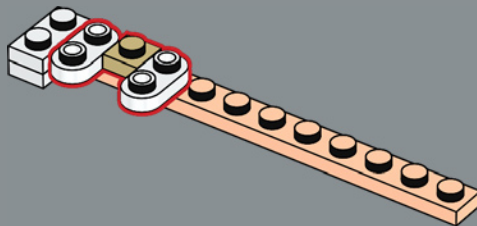

154

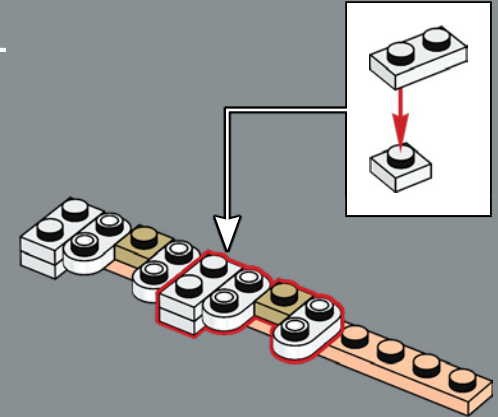

155

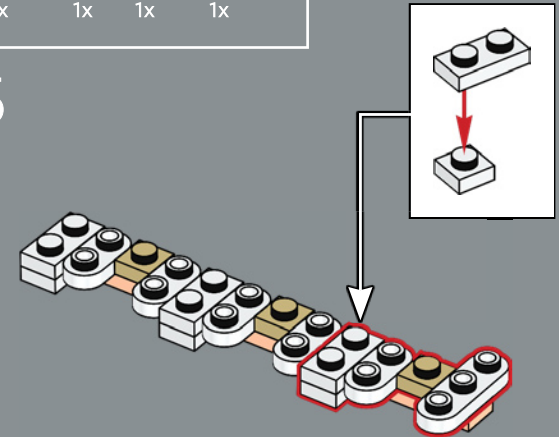

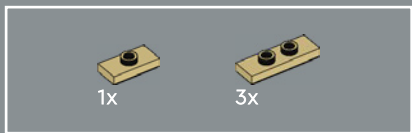

156

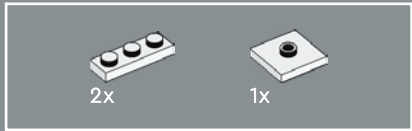
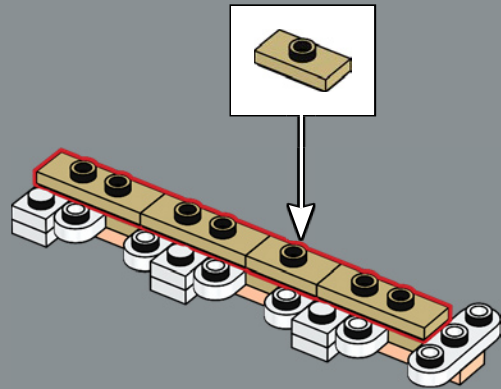

157

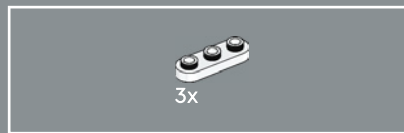
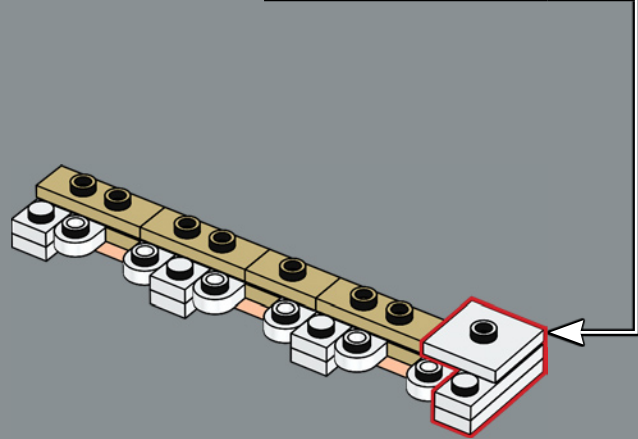
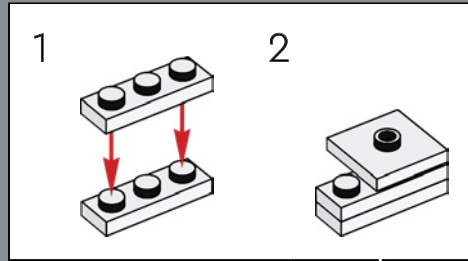

158

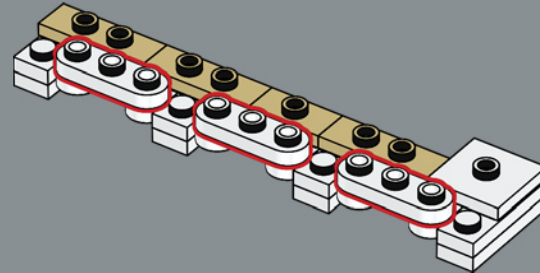

159

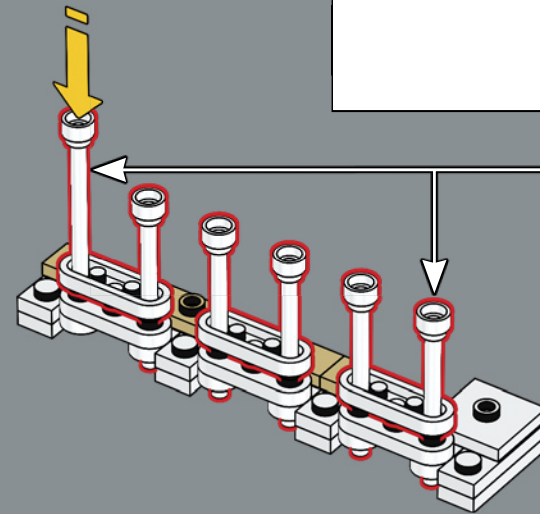
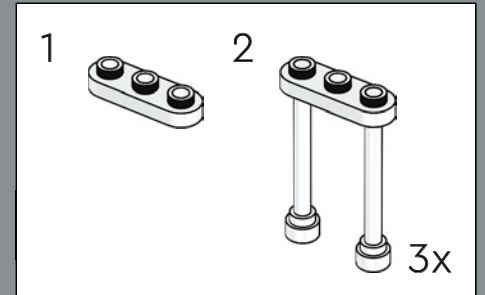

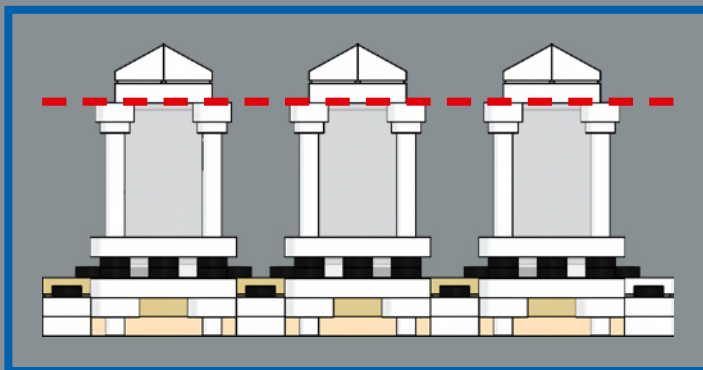
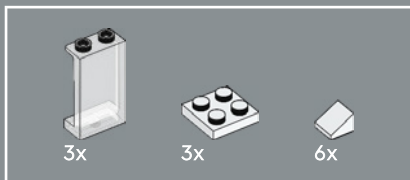

160

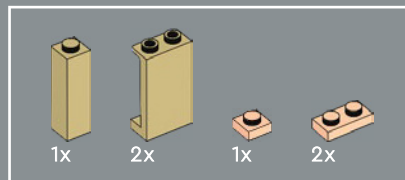
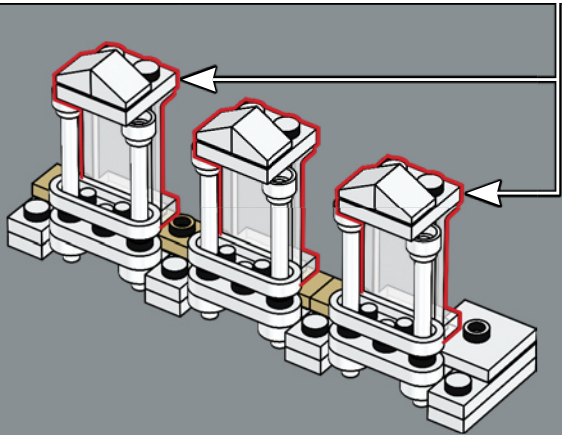
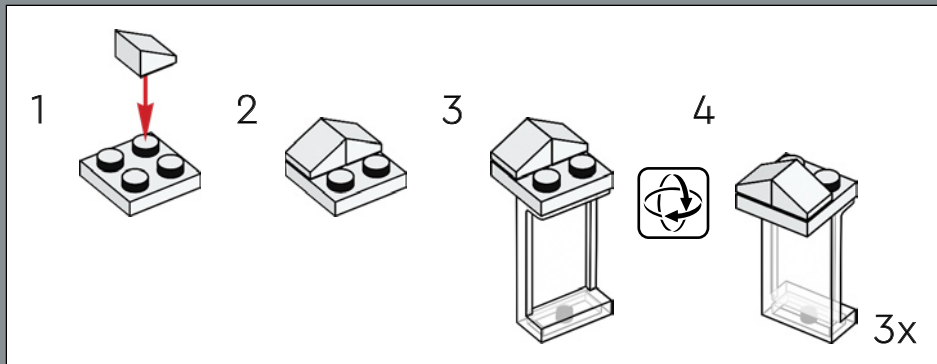

161

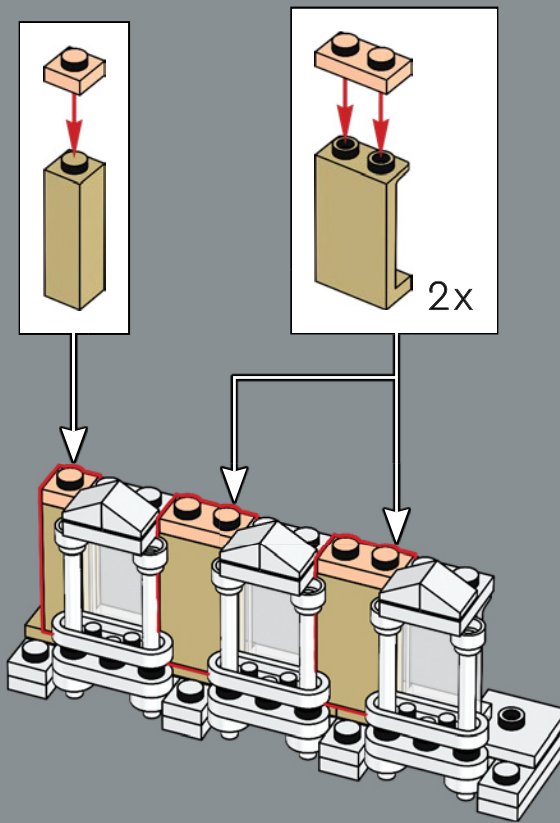

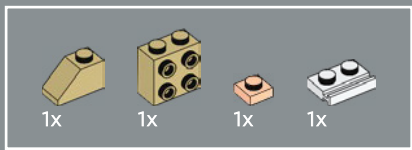

162

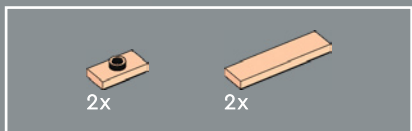
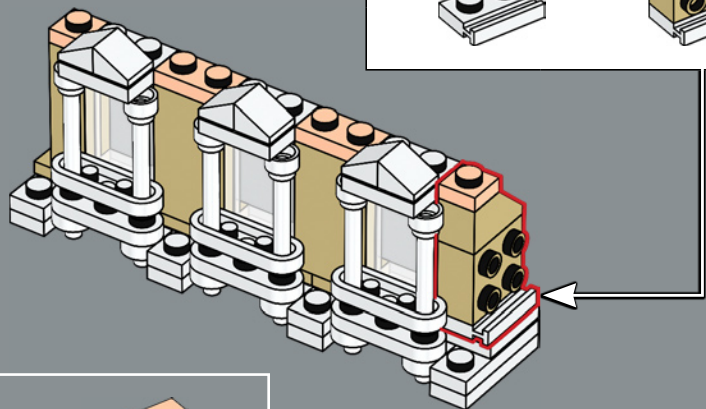
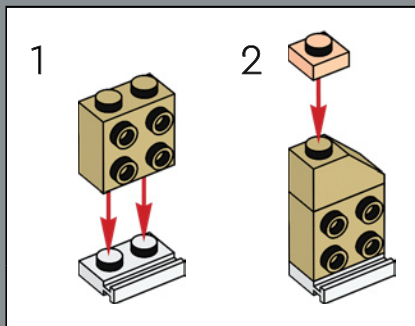

163

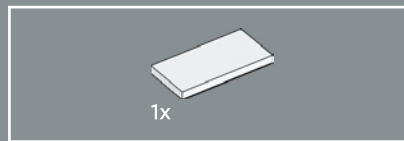
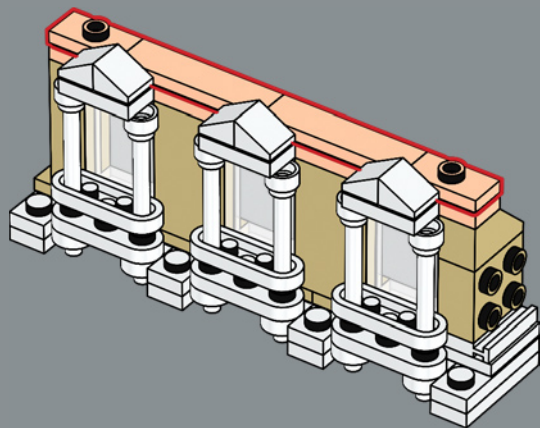

164

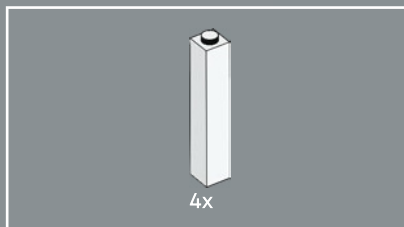
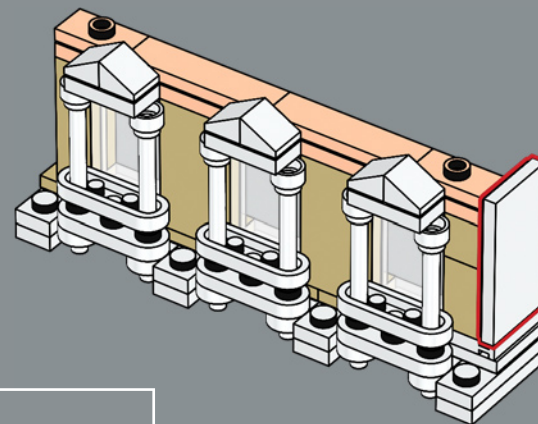

165

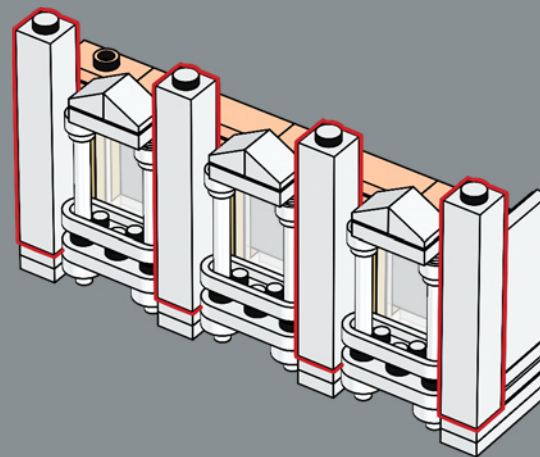

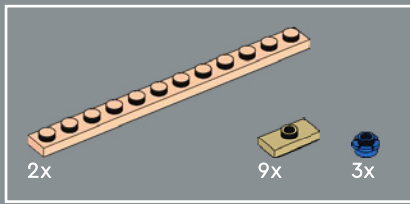

166

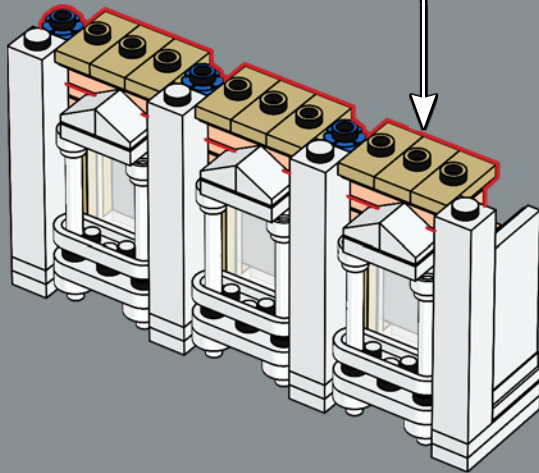
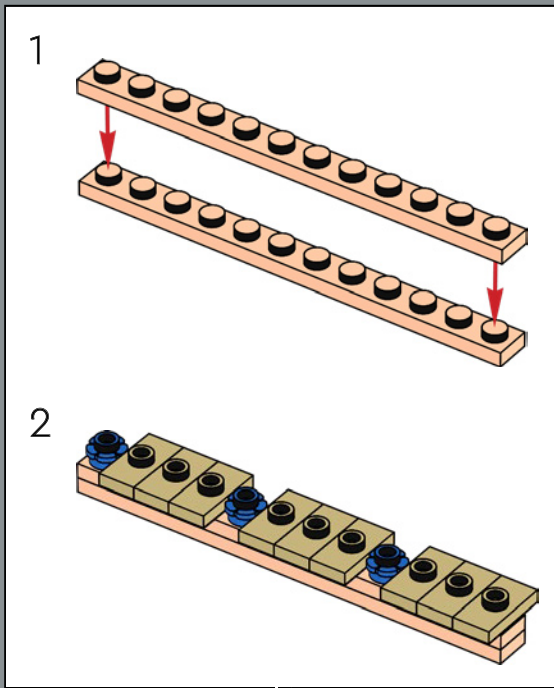

167

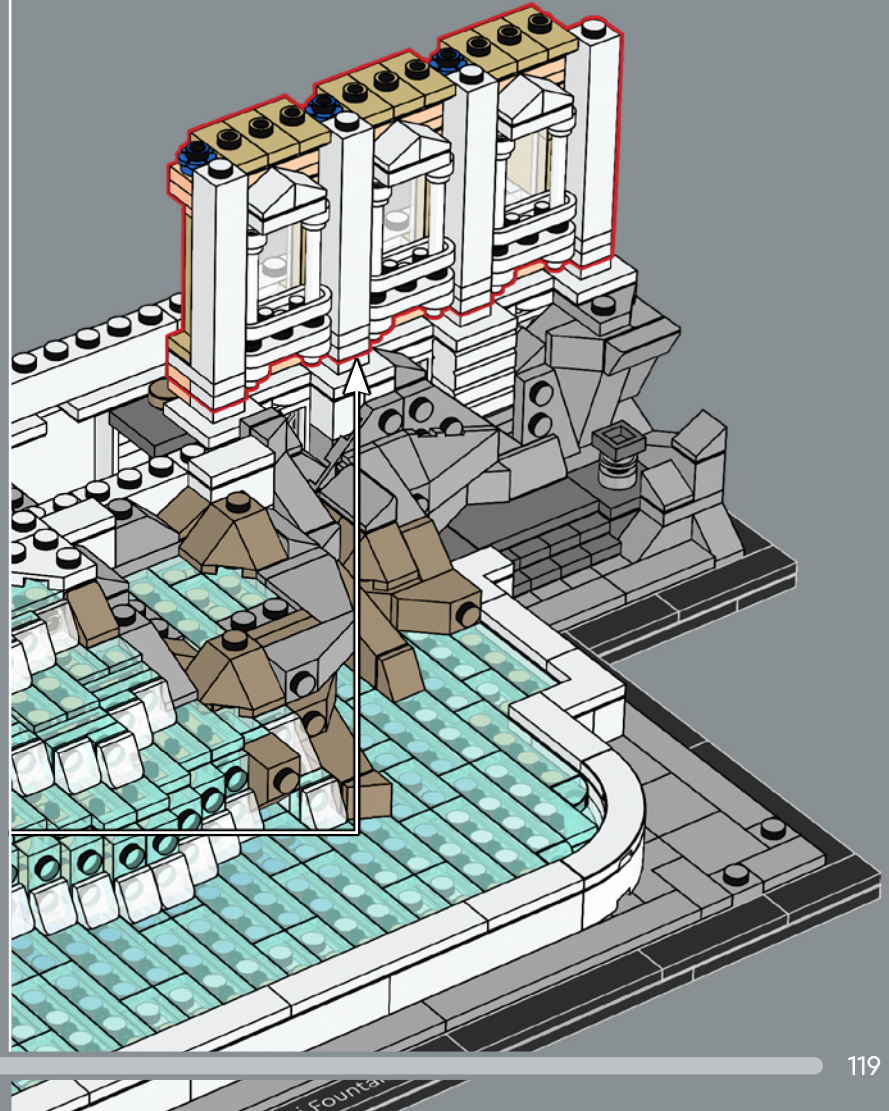

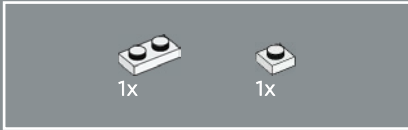
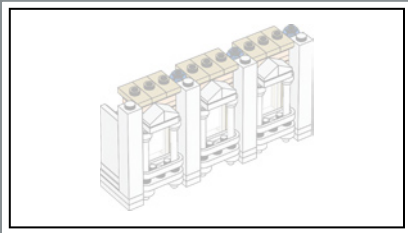

168

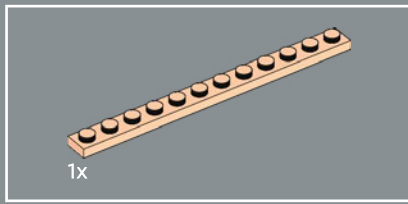
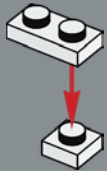

169

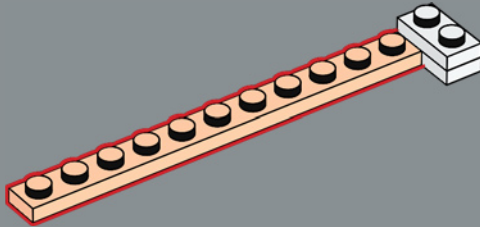

170

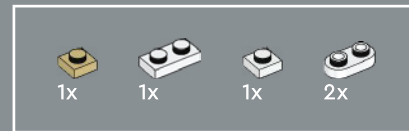
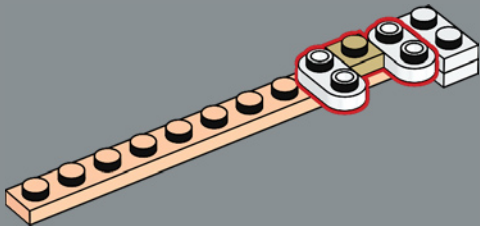

171

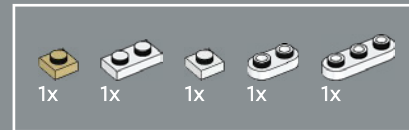
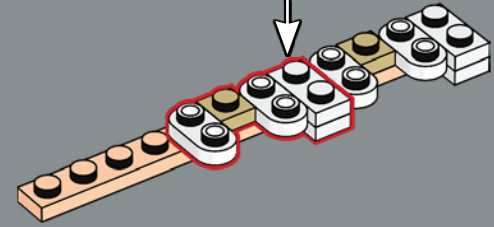
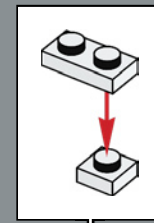

172

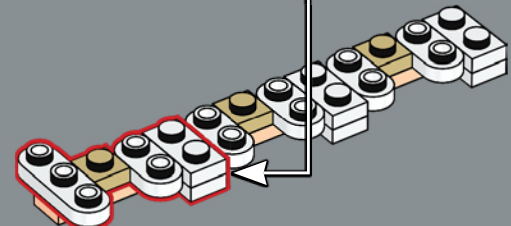
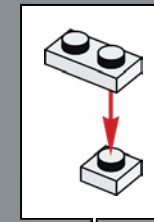

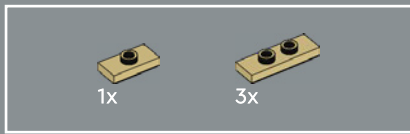

173

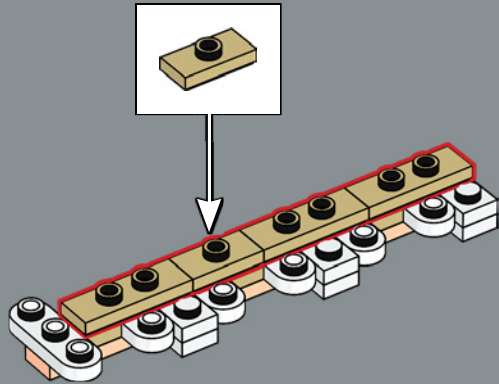

174

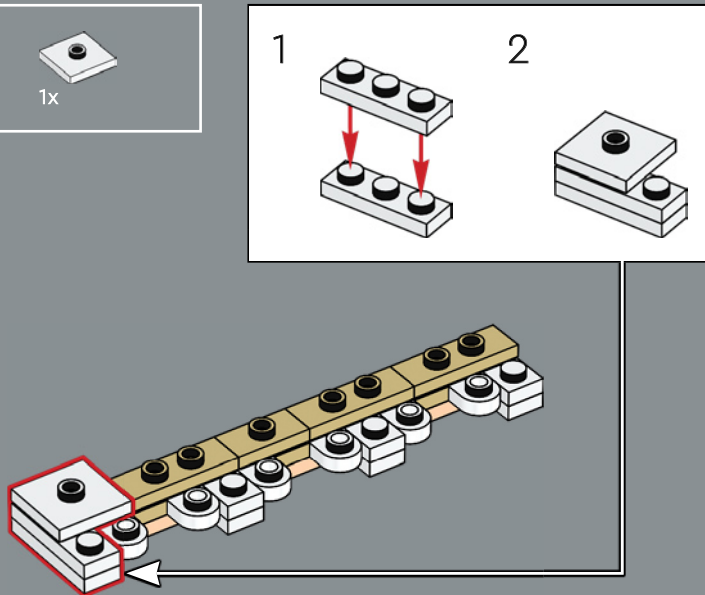

175

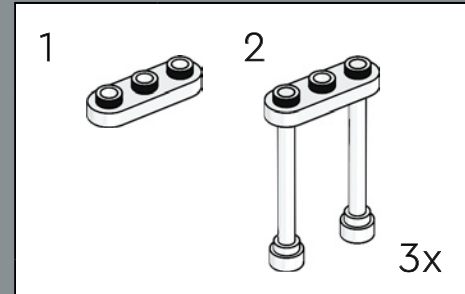
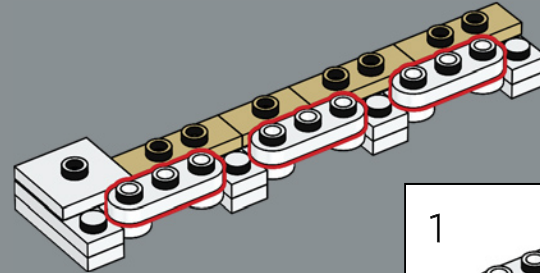

176

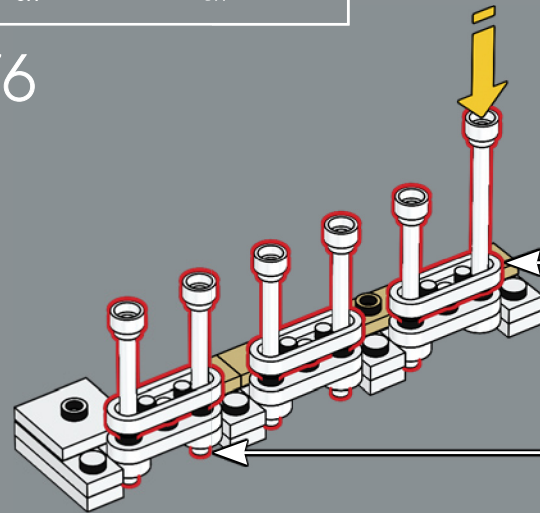

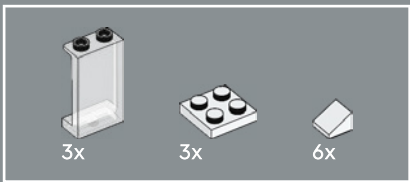

177

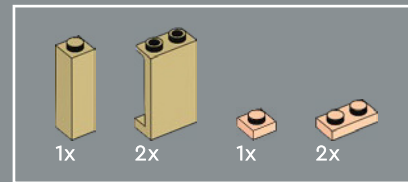
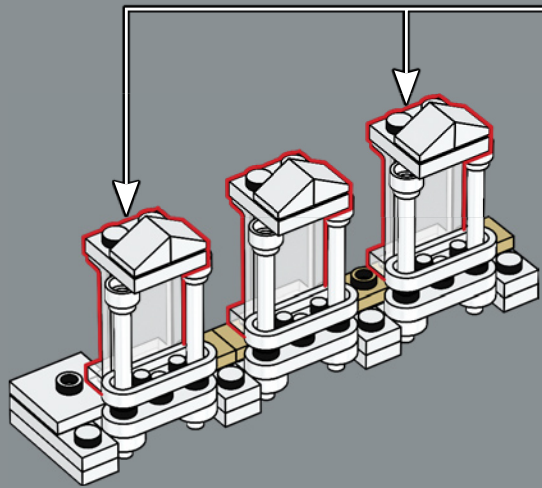
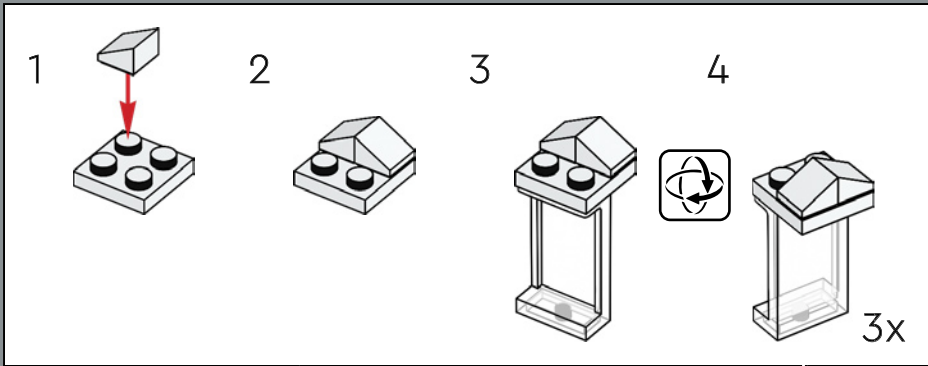
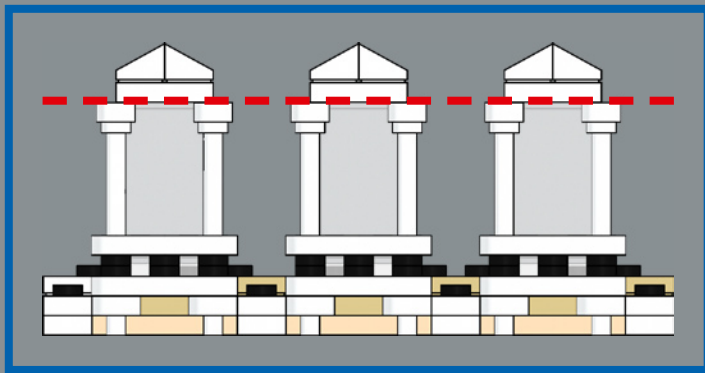

178

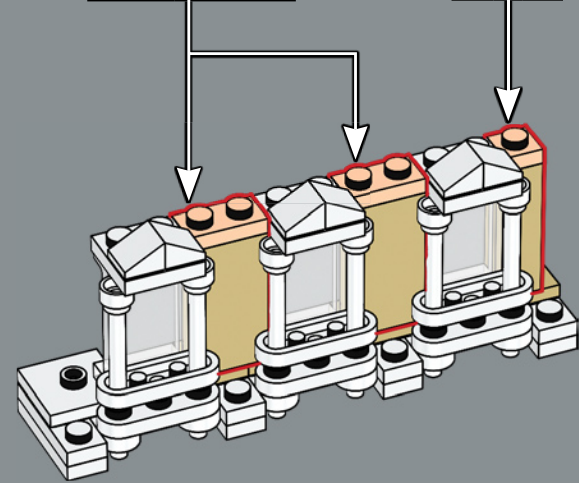
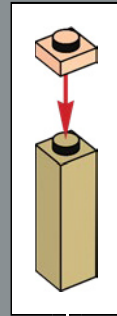
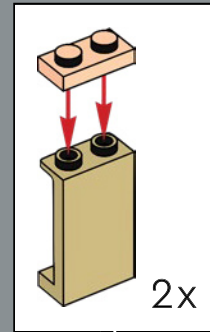

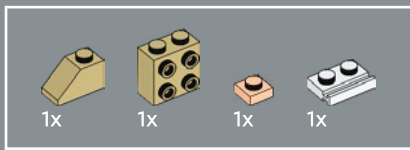

179

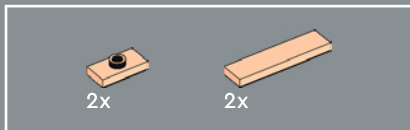
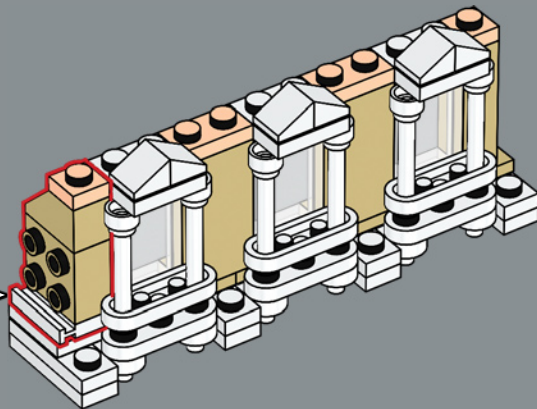
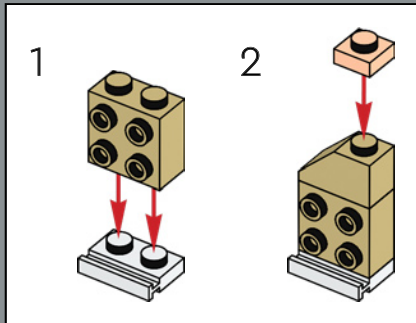

180

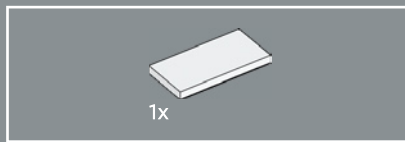
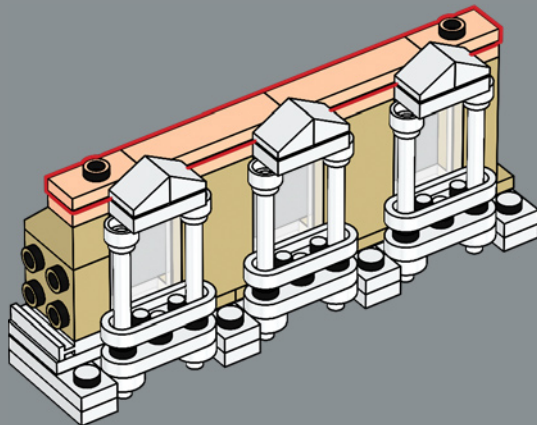

181

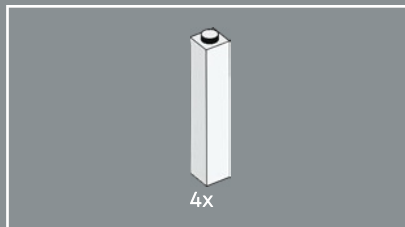
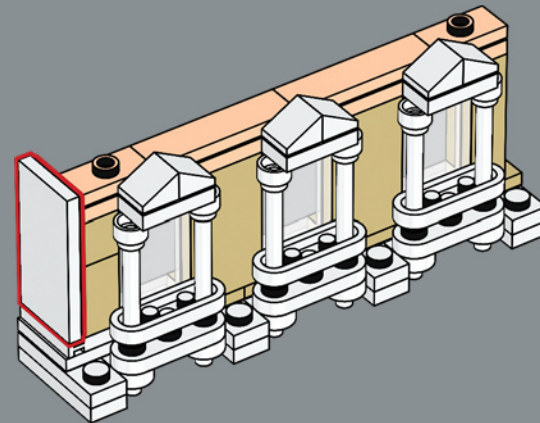

182

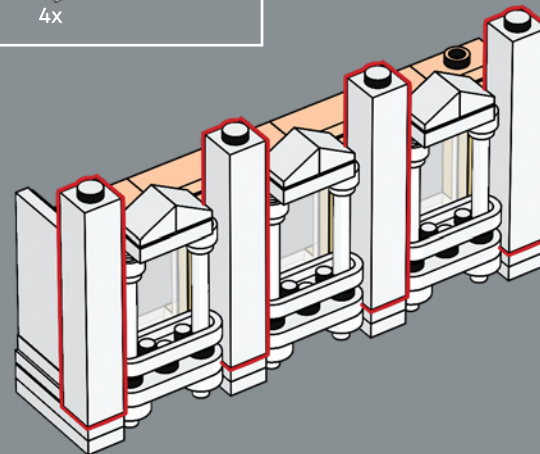

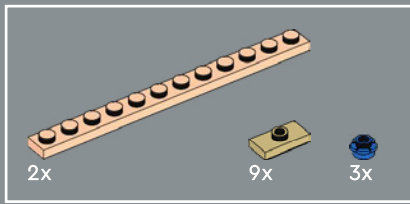

183

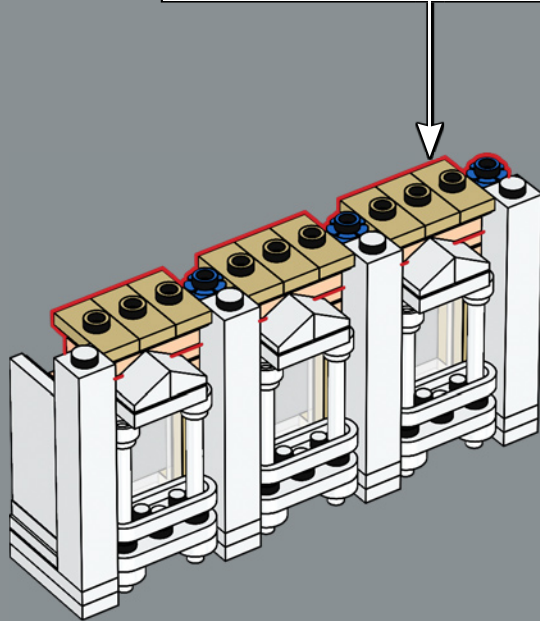
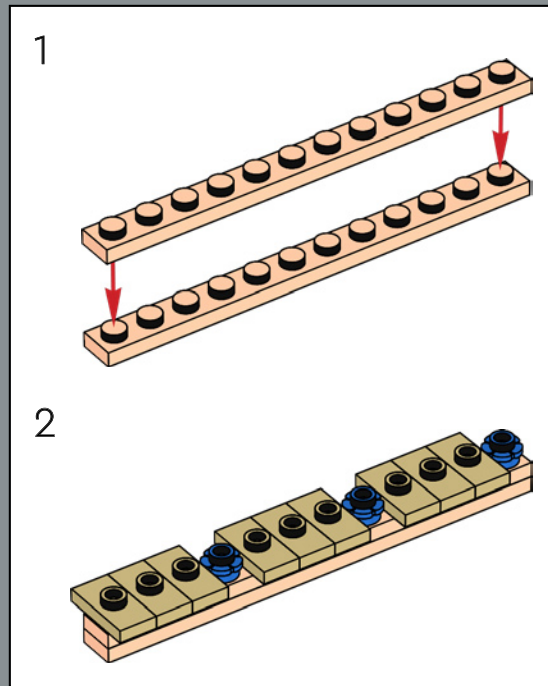

184

La couleur sable est uniquement utilisée pour les zones les plus ombragées de la fontaine, sous les surplombs et derrière les encadrements de fenêtres.

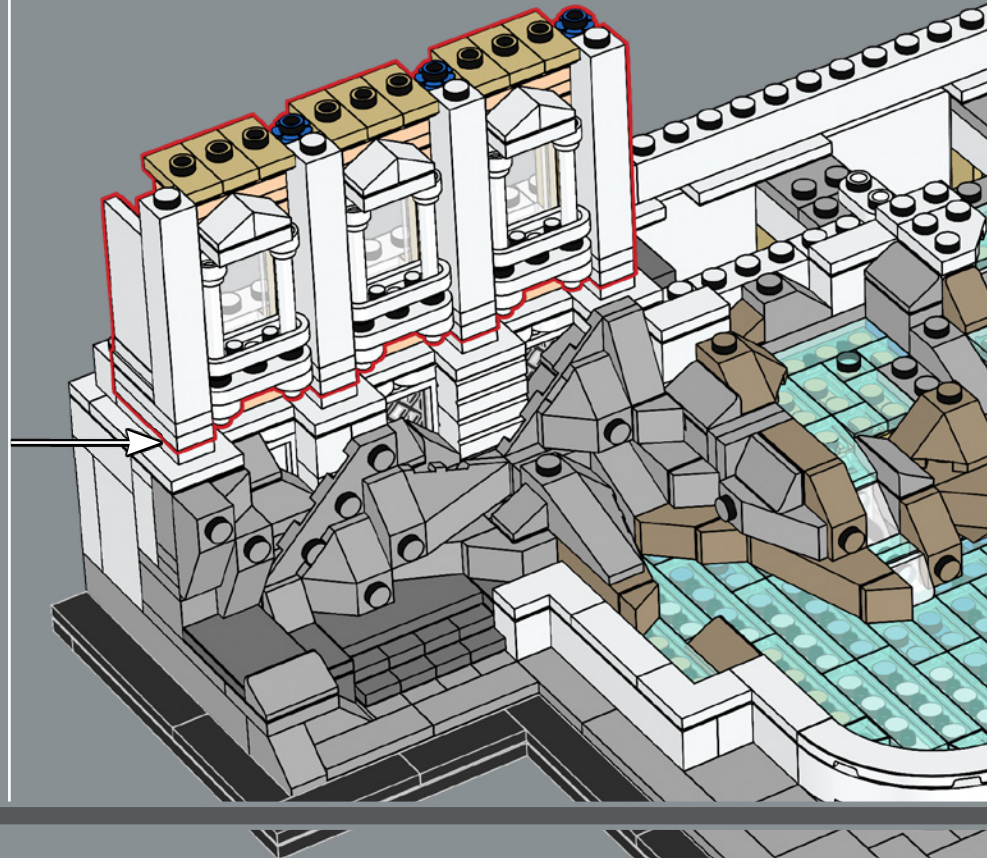

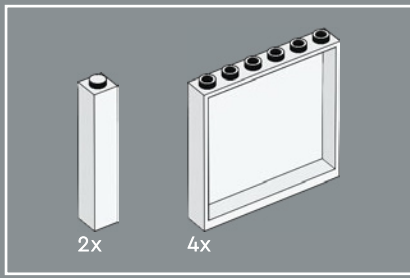

185

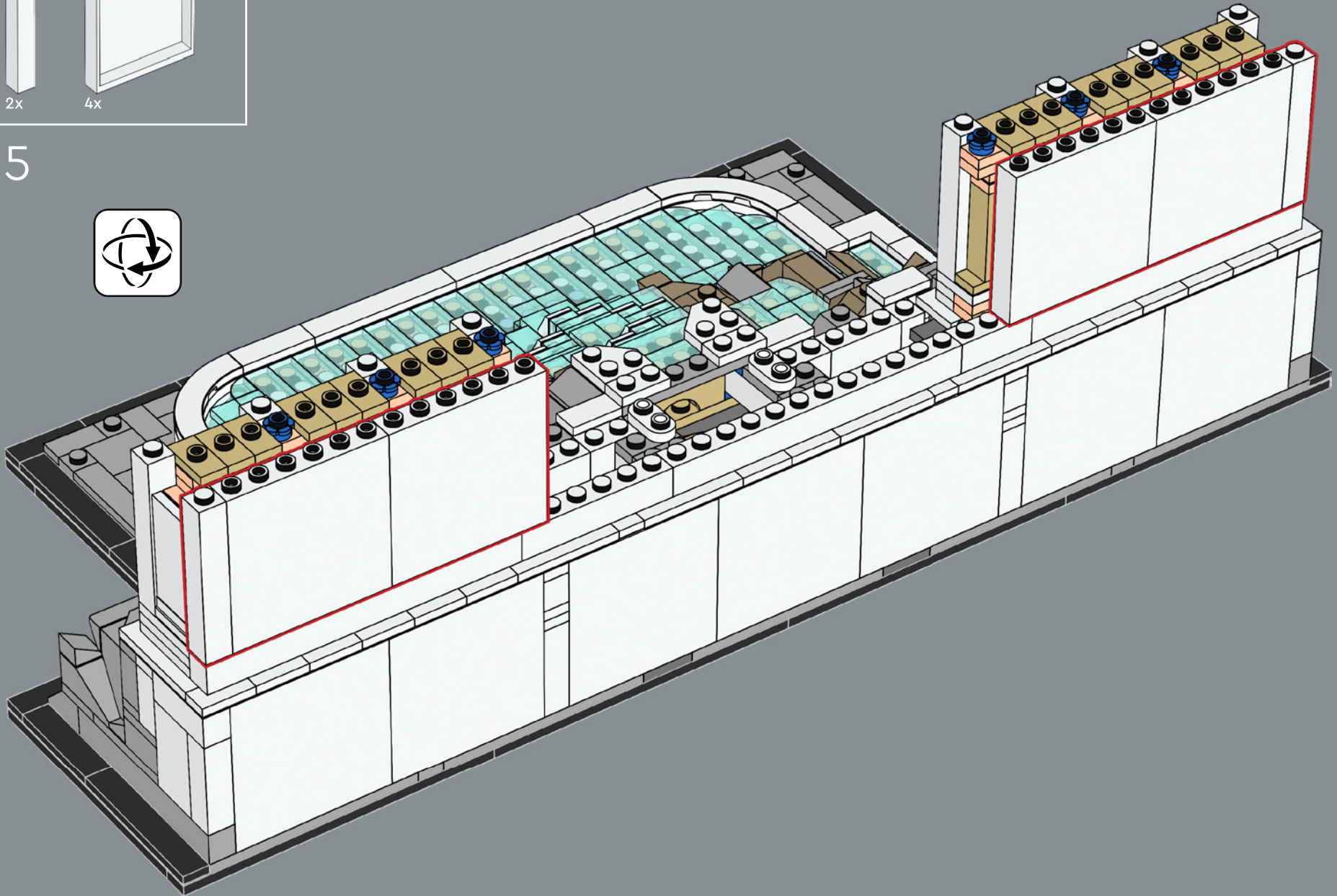

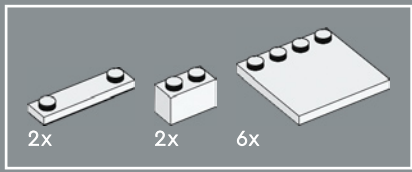

186

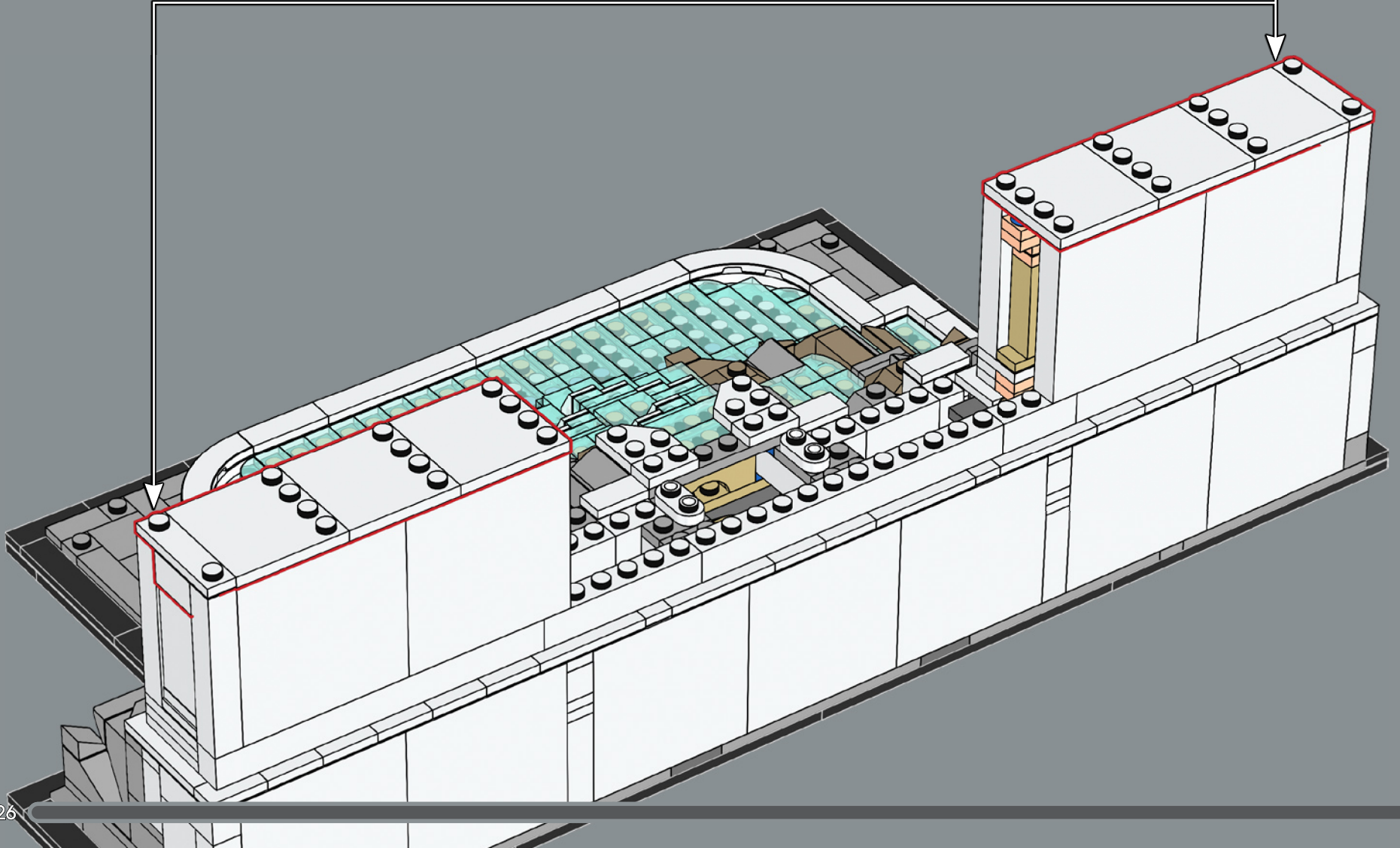
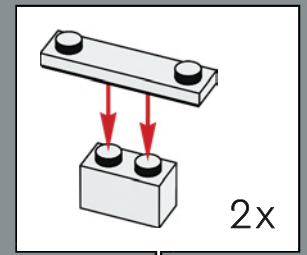

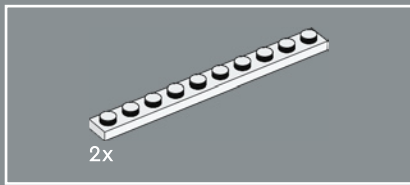

187

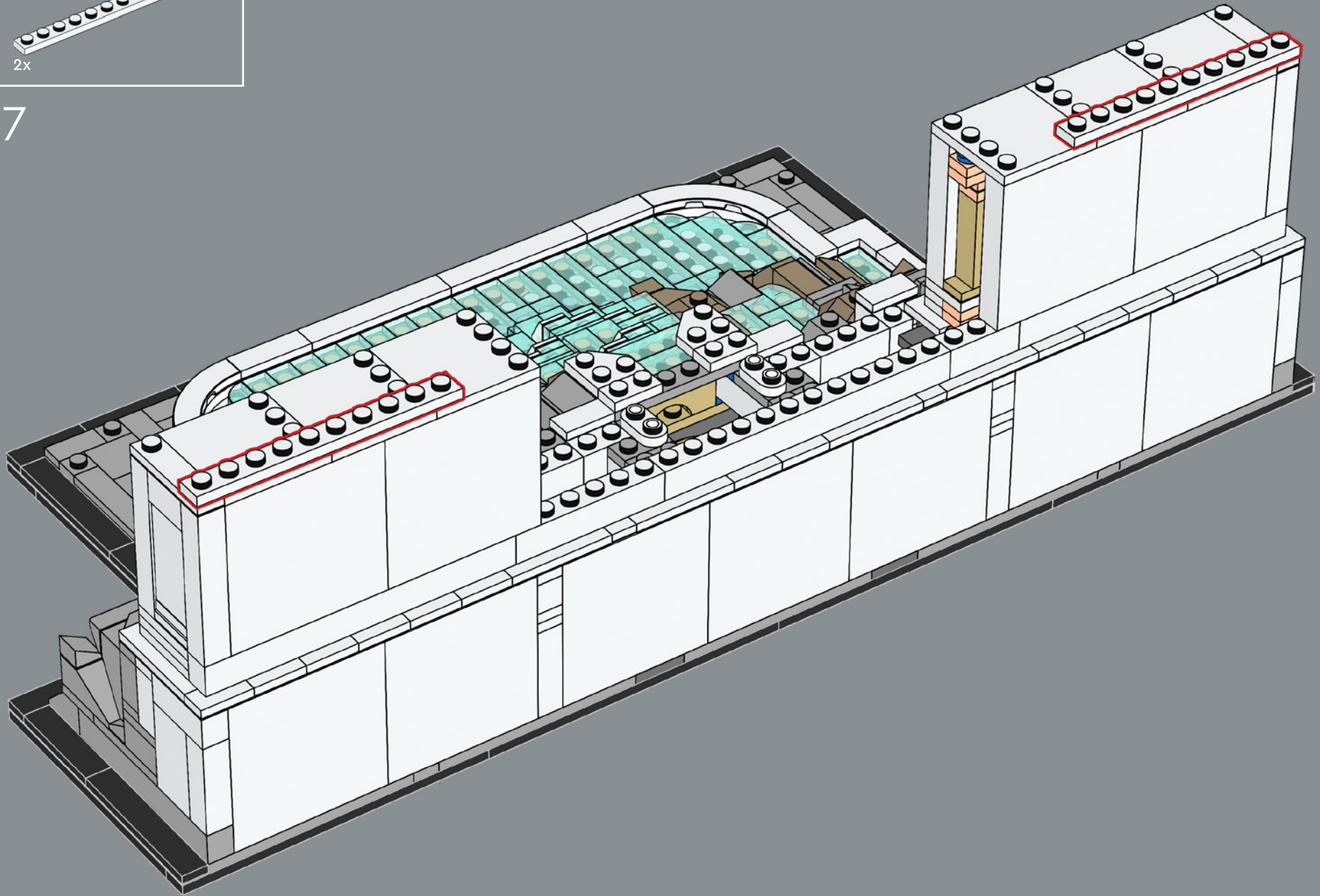

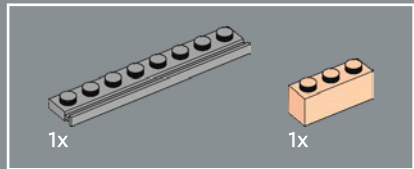
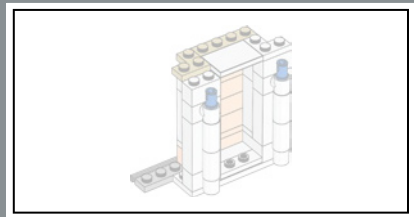

188

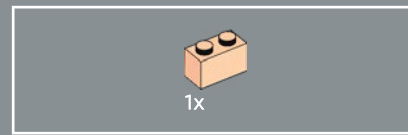
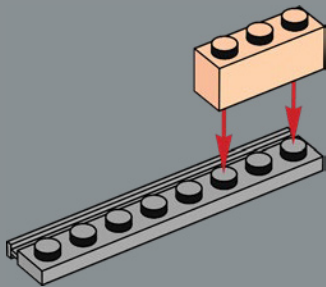

189

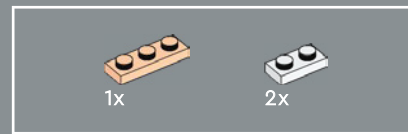
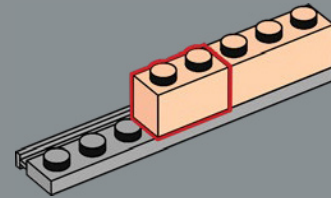

190

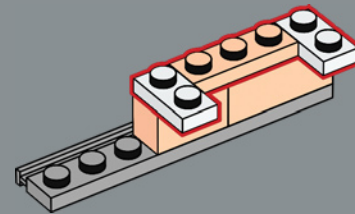

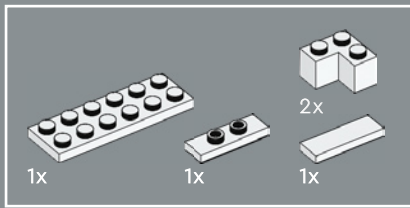

191

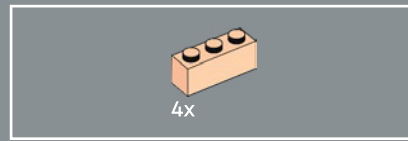
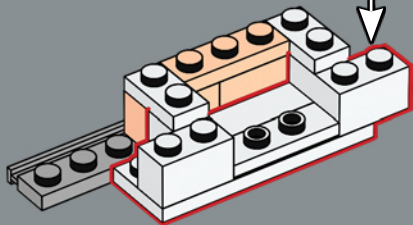
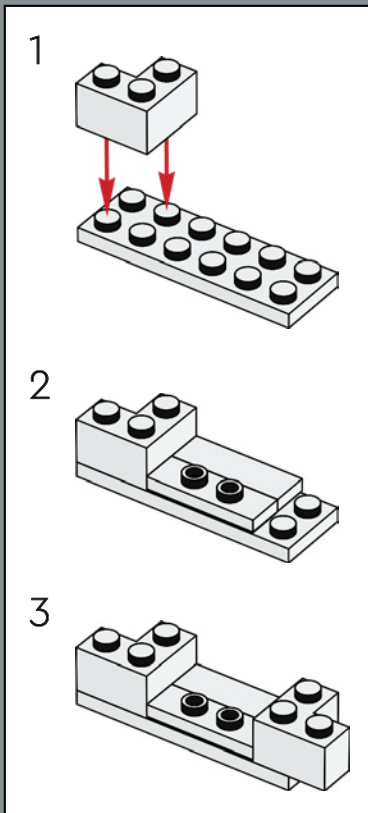

192

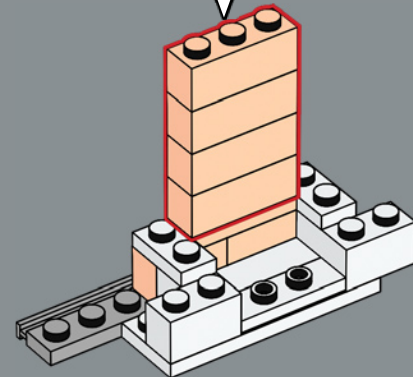
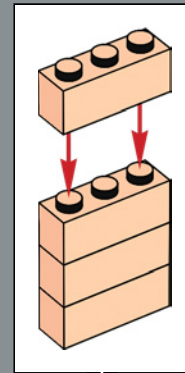

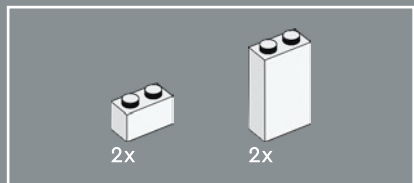

193

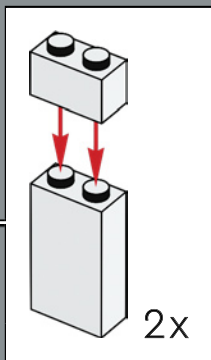
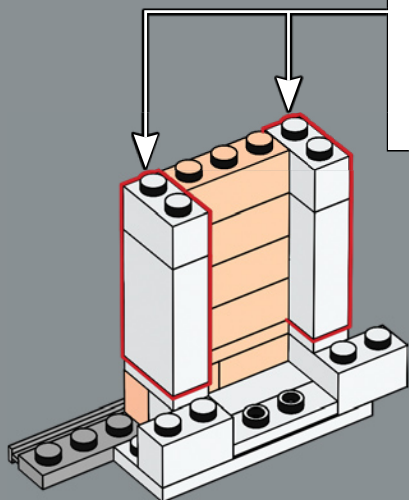

2x

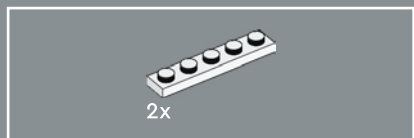

194

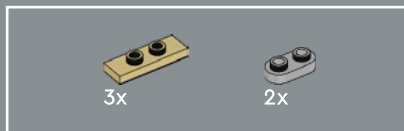
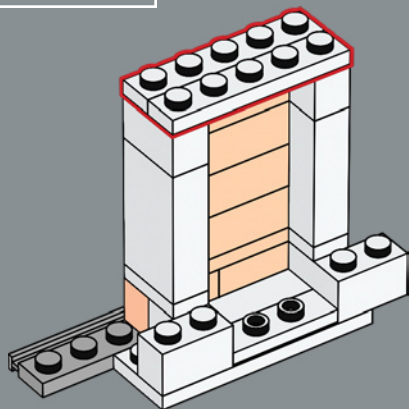

195

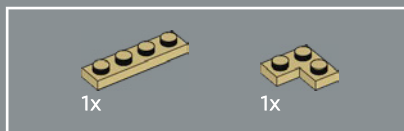
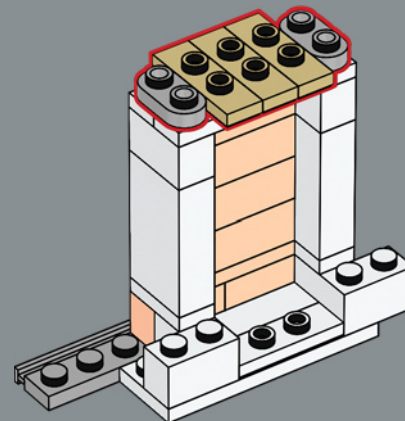

196

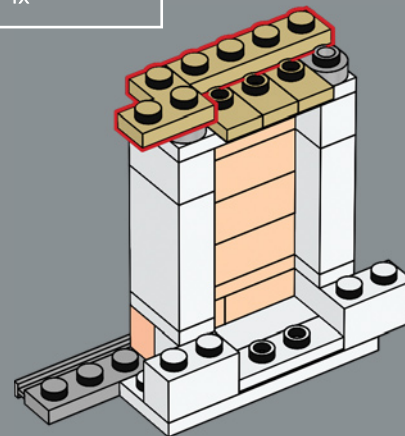

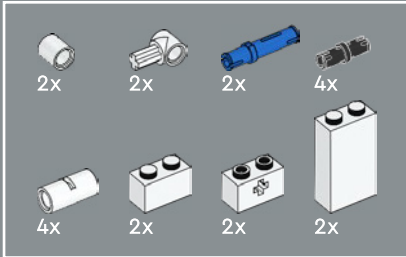
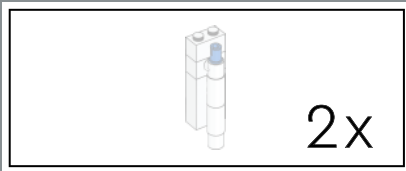

197

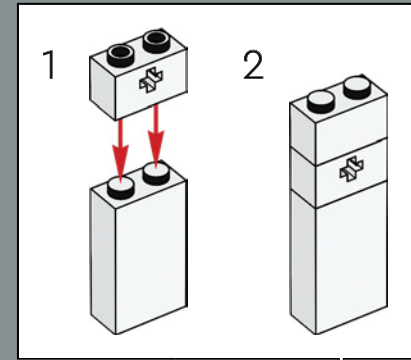
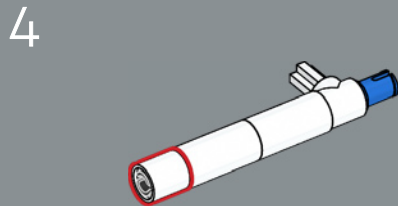
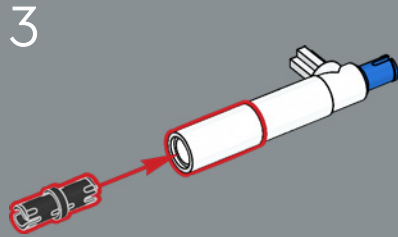
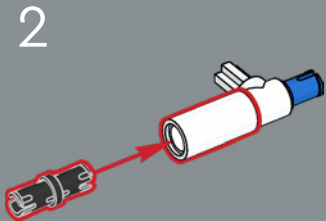
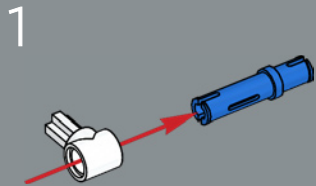

5

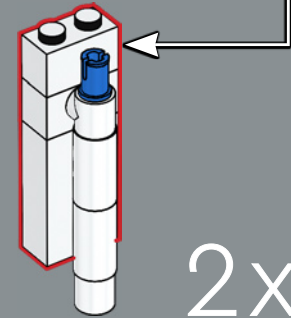

2x

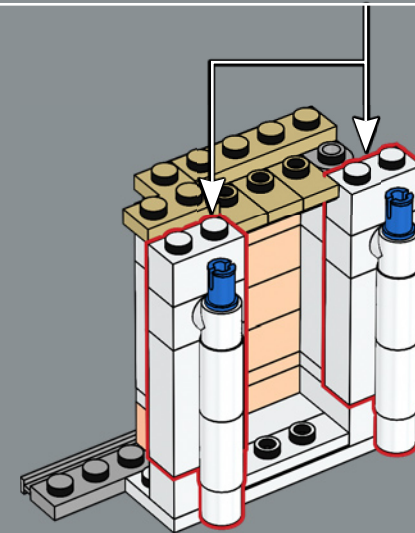

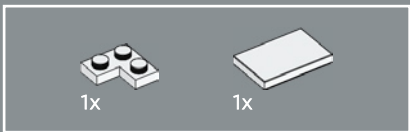

198

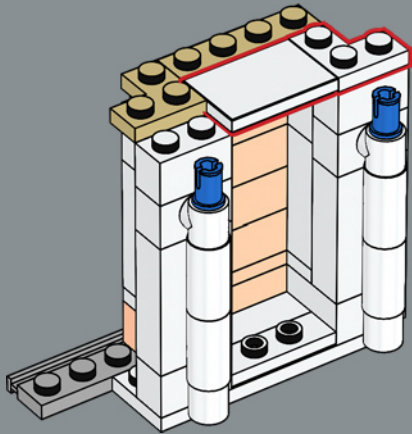

199

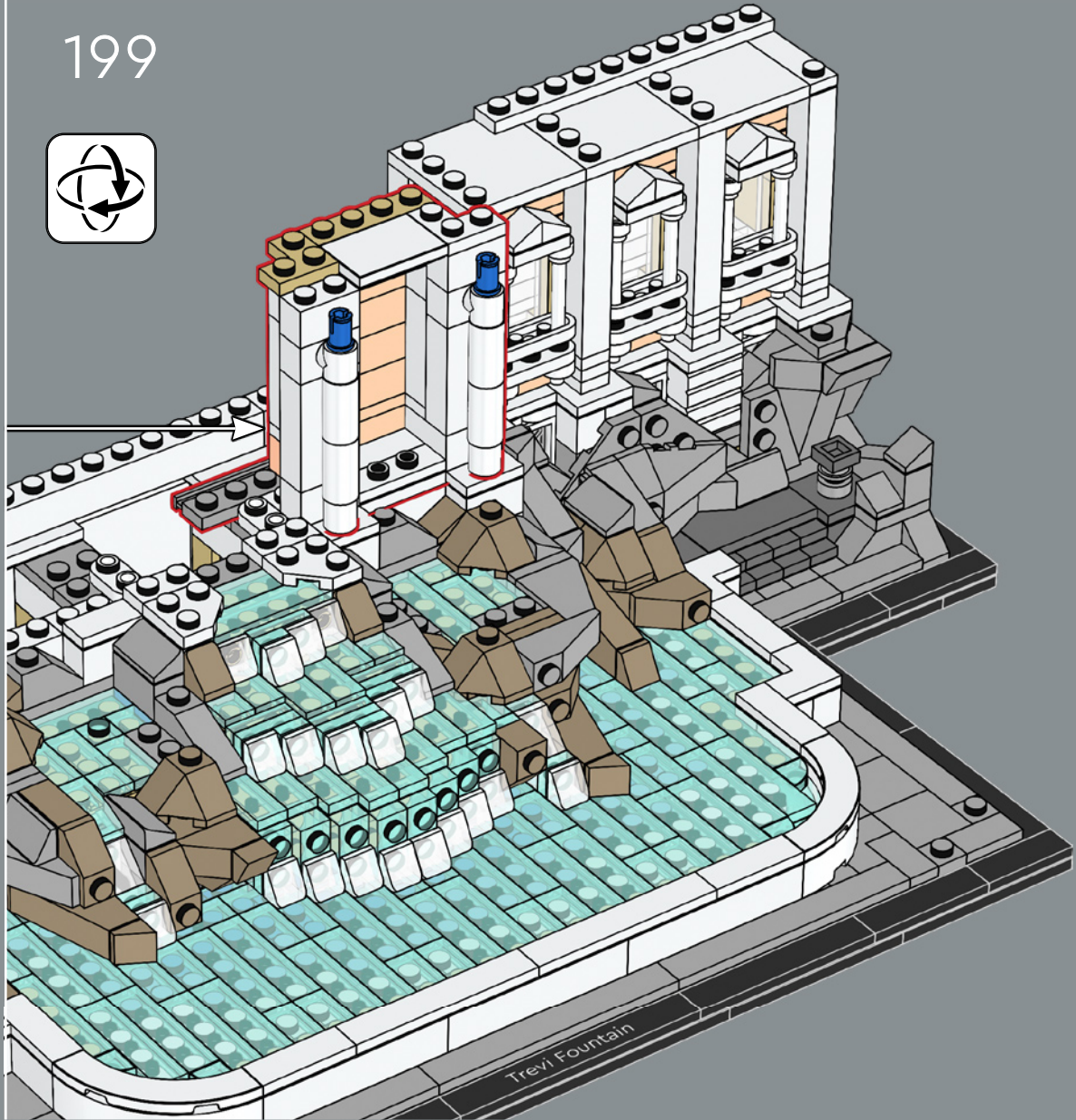

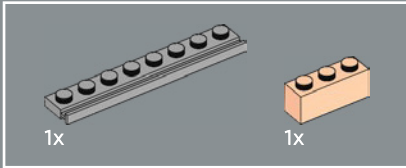
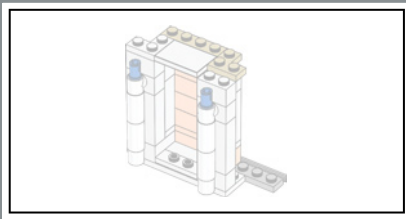

200

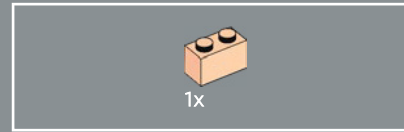
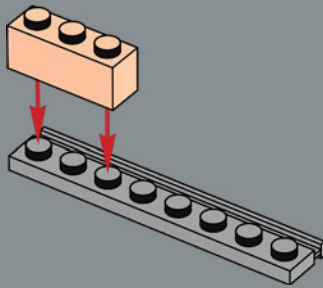

201

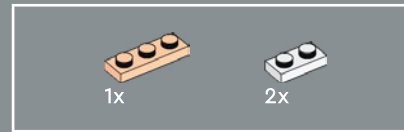
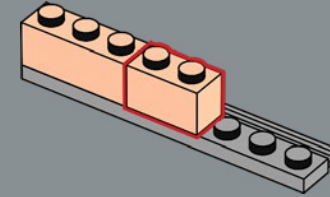

202

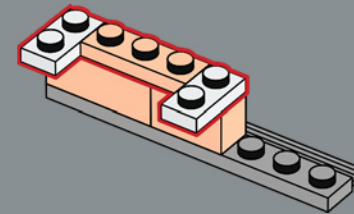

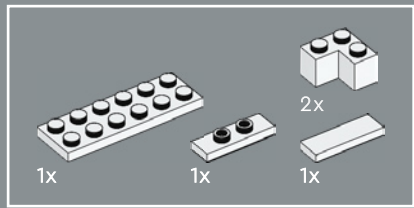

203

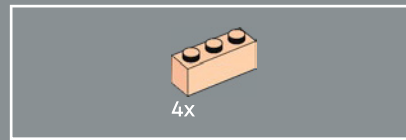
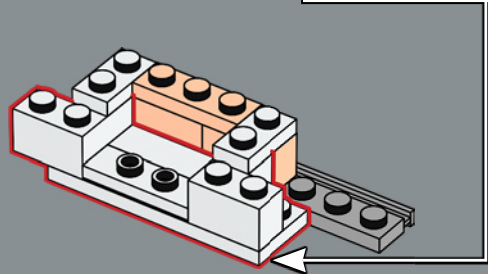
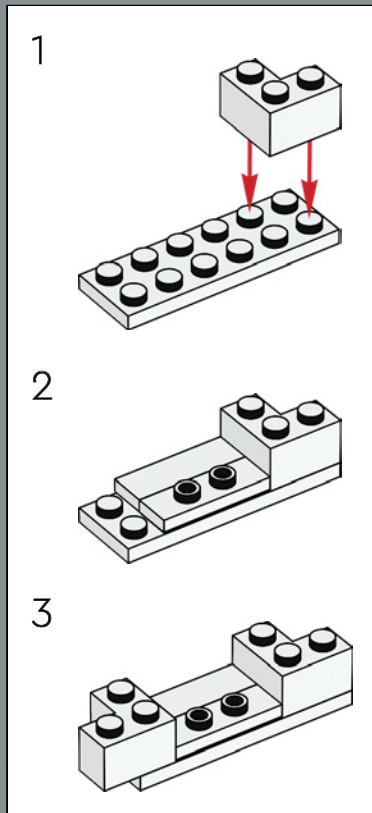

204

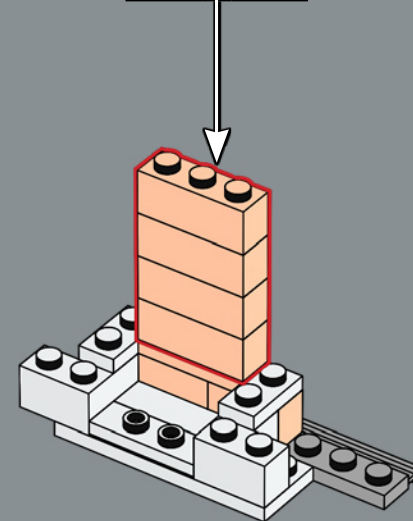
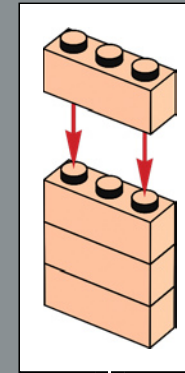

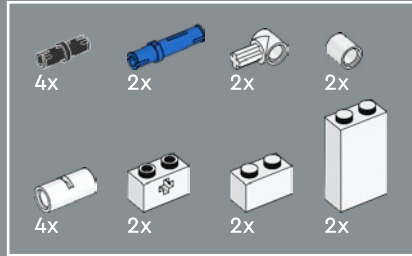
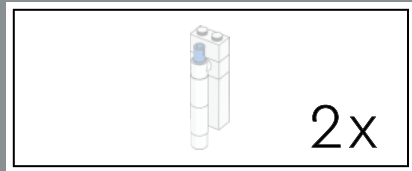

209

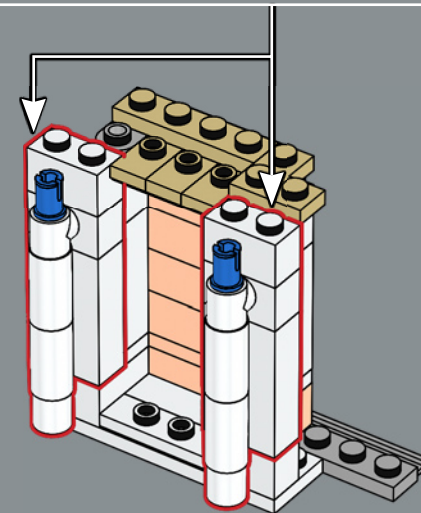
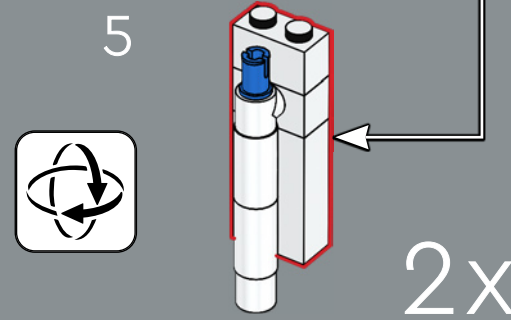
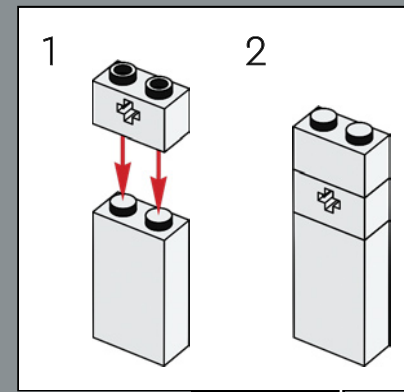
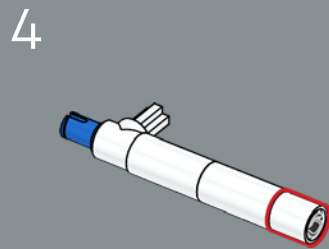
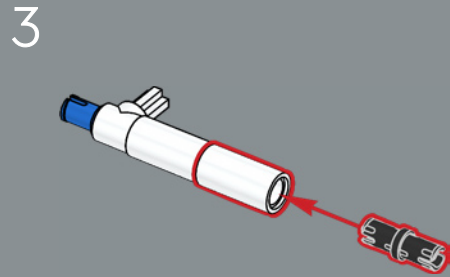
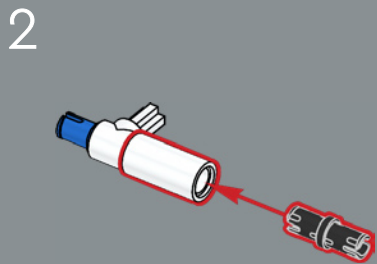
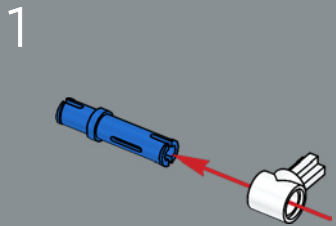

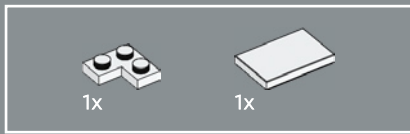

210

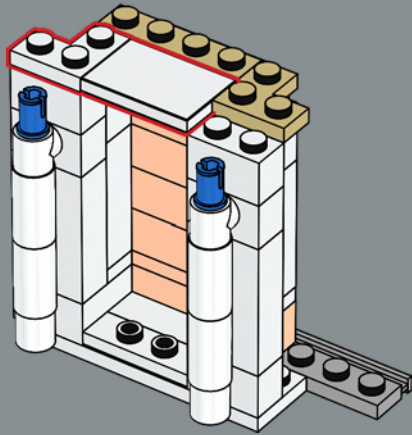

211

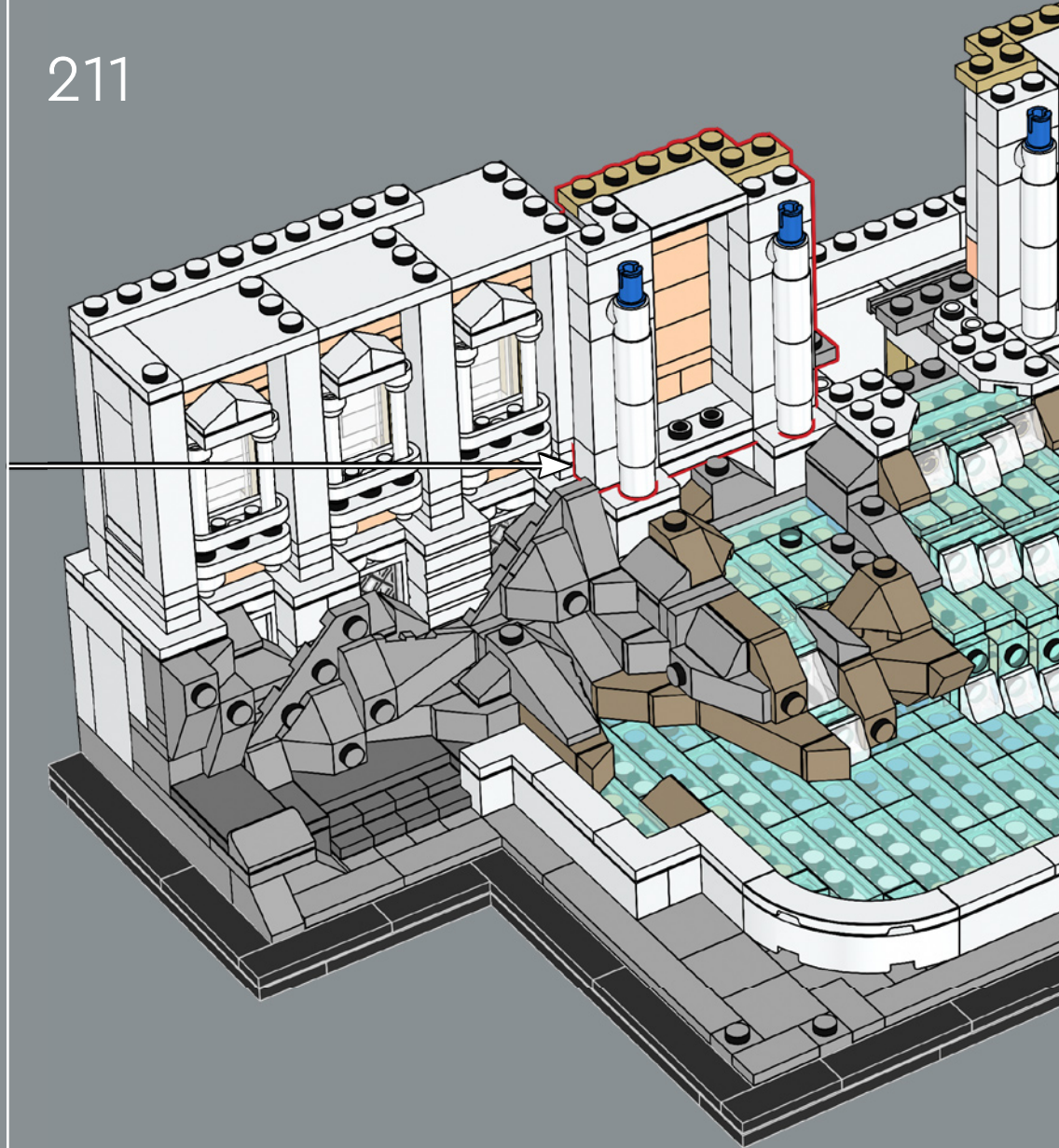

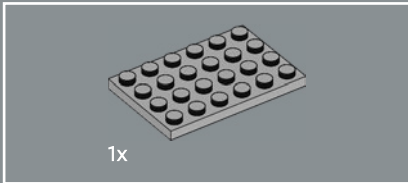
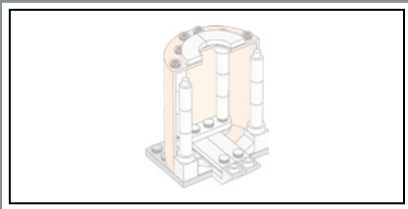

1x

212

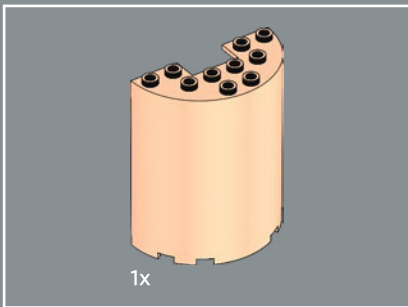
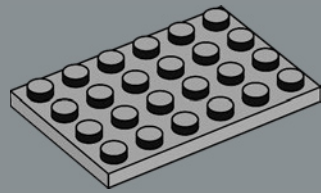

1x

213

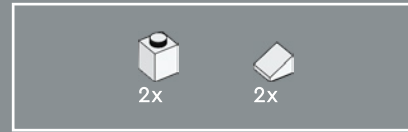
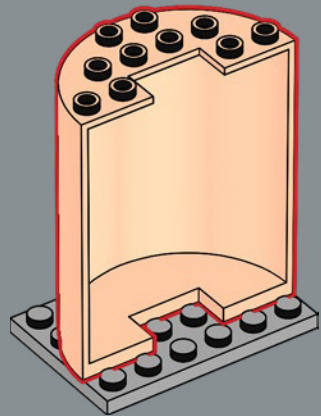

2x

2x

214

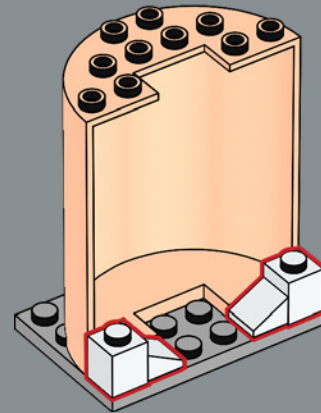

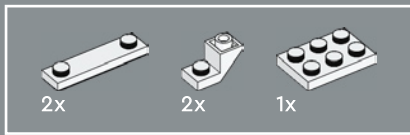

215

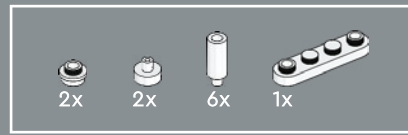
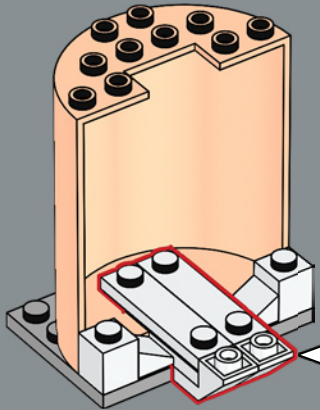
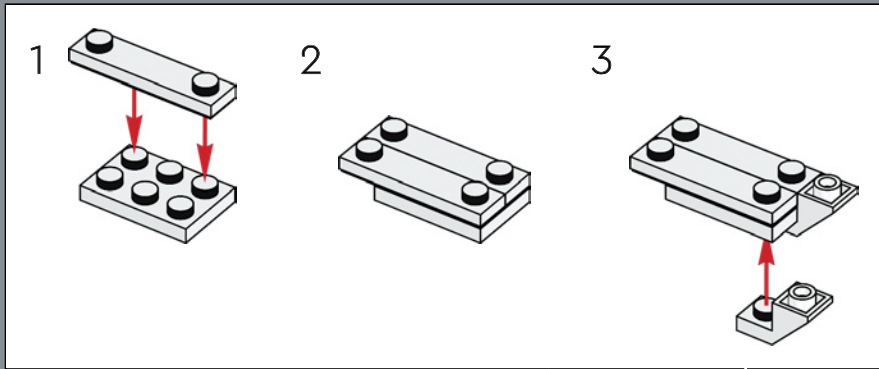

216

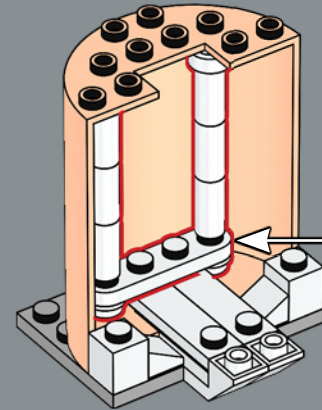
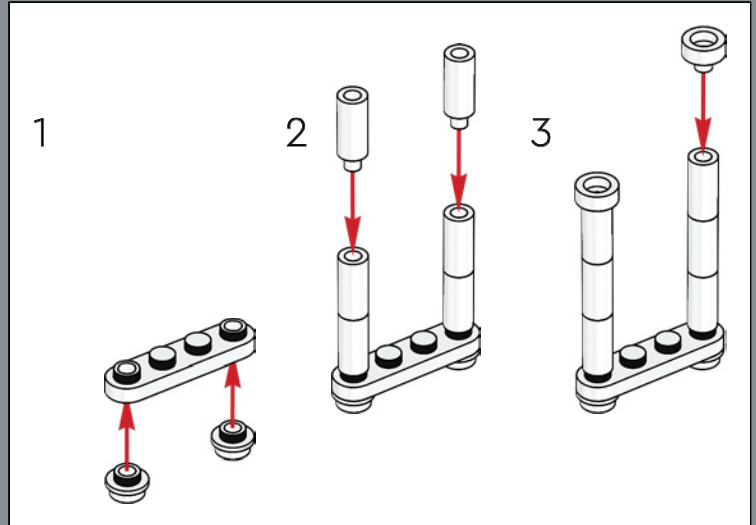



217

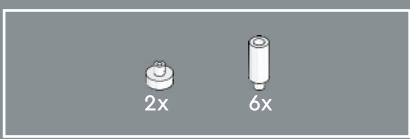
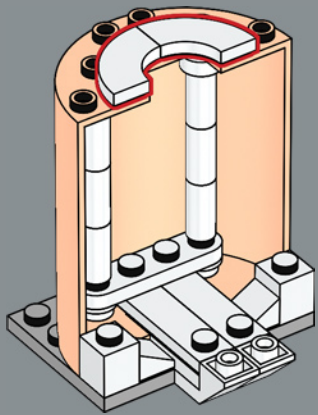

218

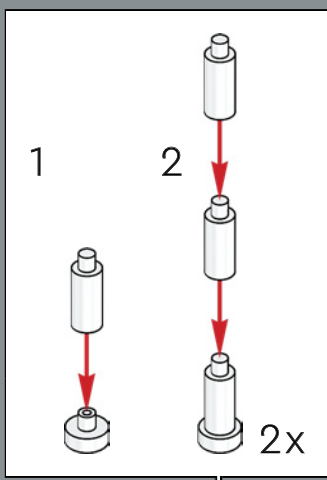
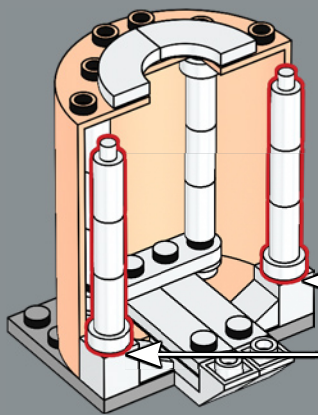

L'ensemble de la façade est divisé en neuf sections verticales, mettant en valeur la partie centrale. Pour reproduire cela avec des briques LEGO®, nous avons utilisé un nombre impair de modules ainsi que des plaques de raccordement permettant de centrer l'arche principale.

219

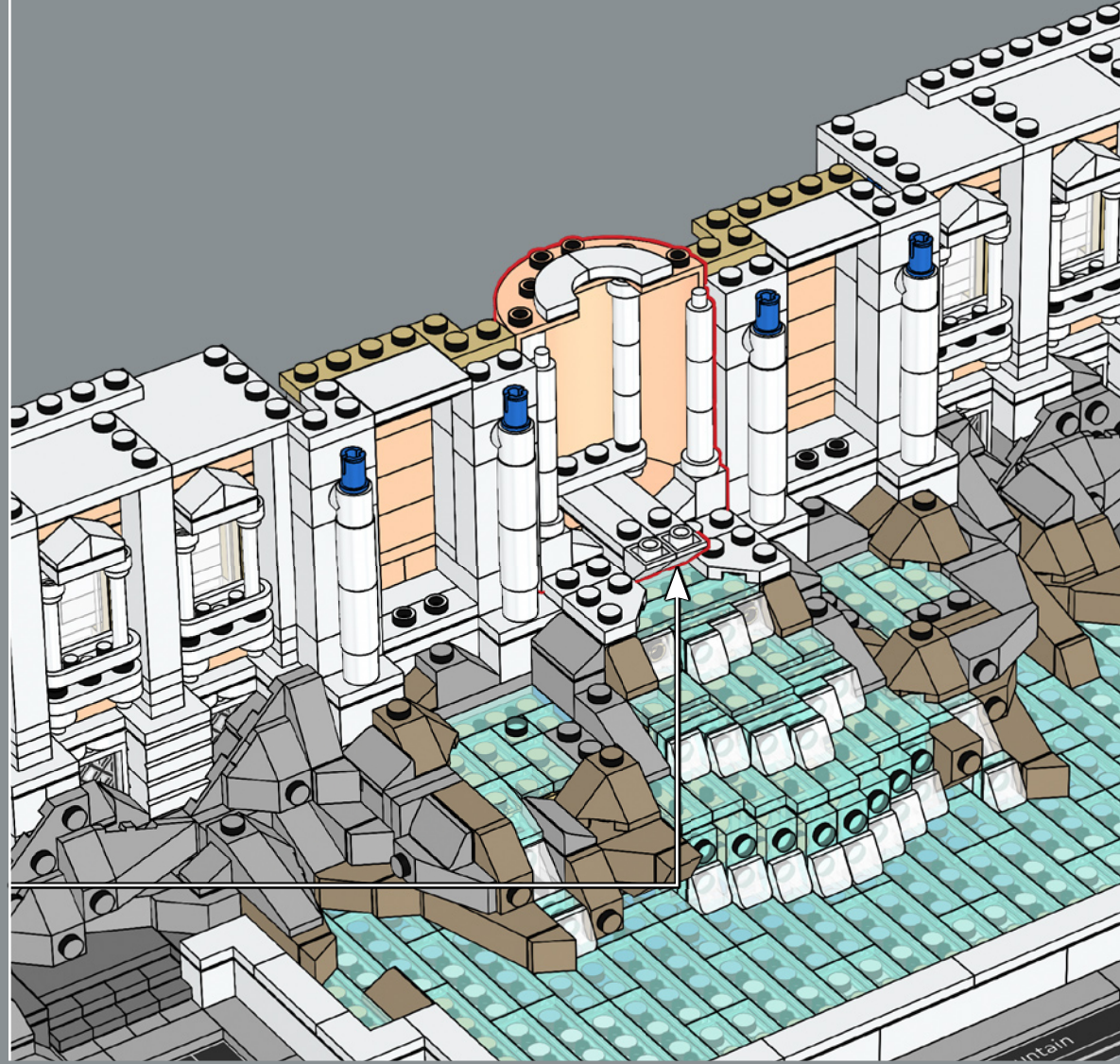

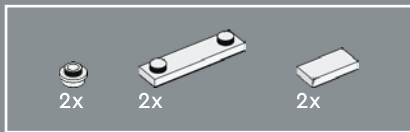

220

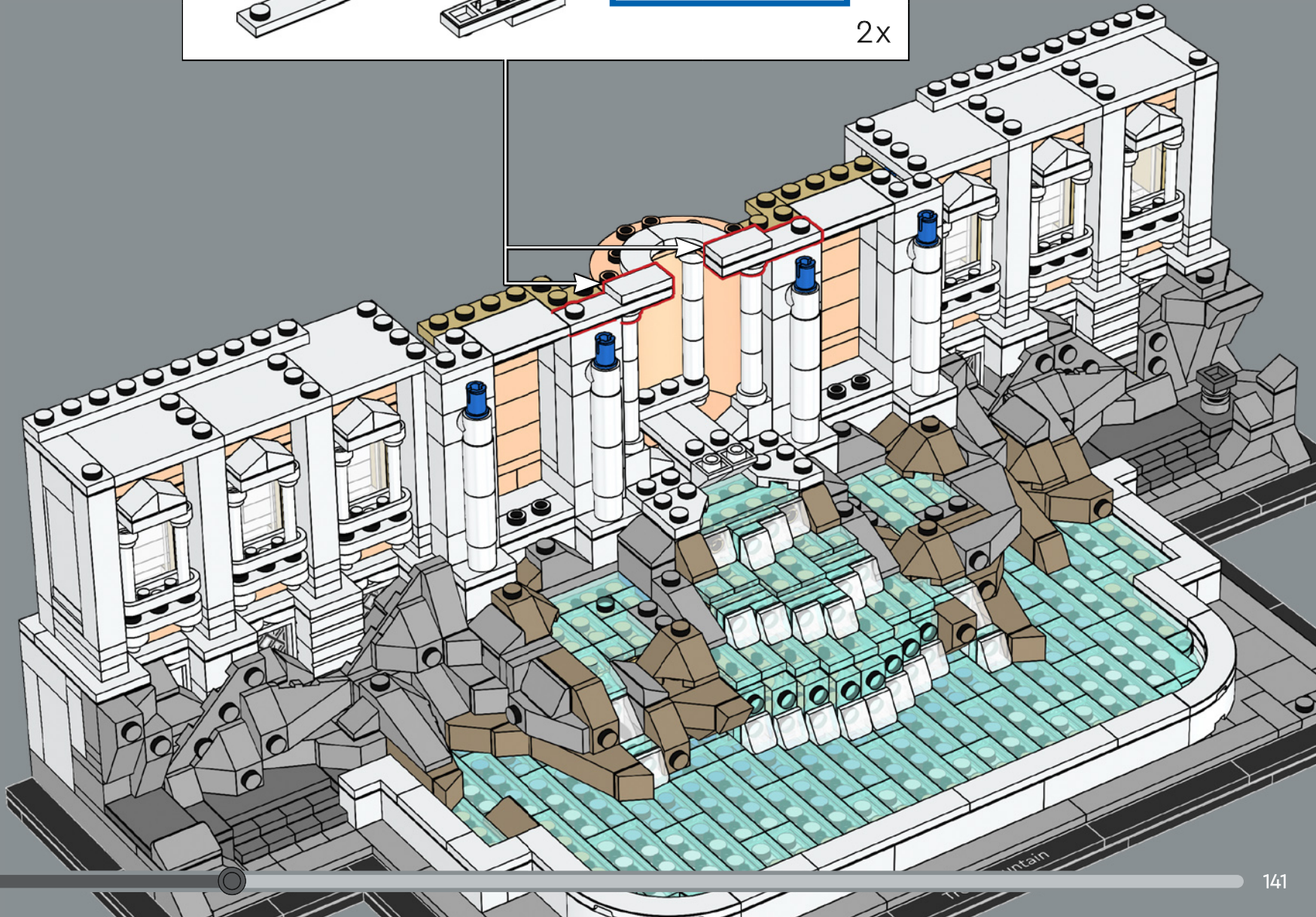
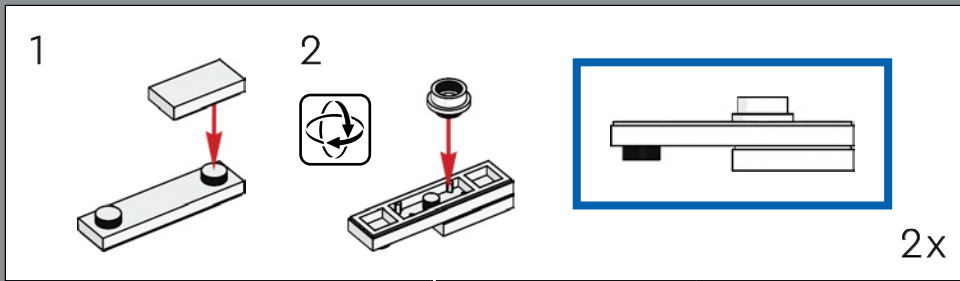

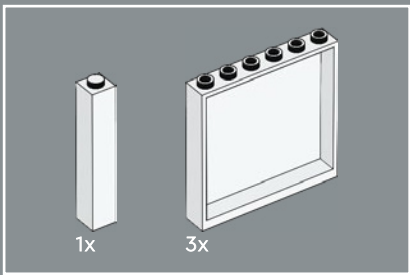

221

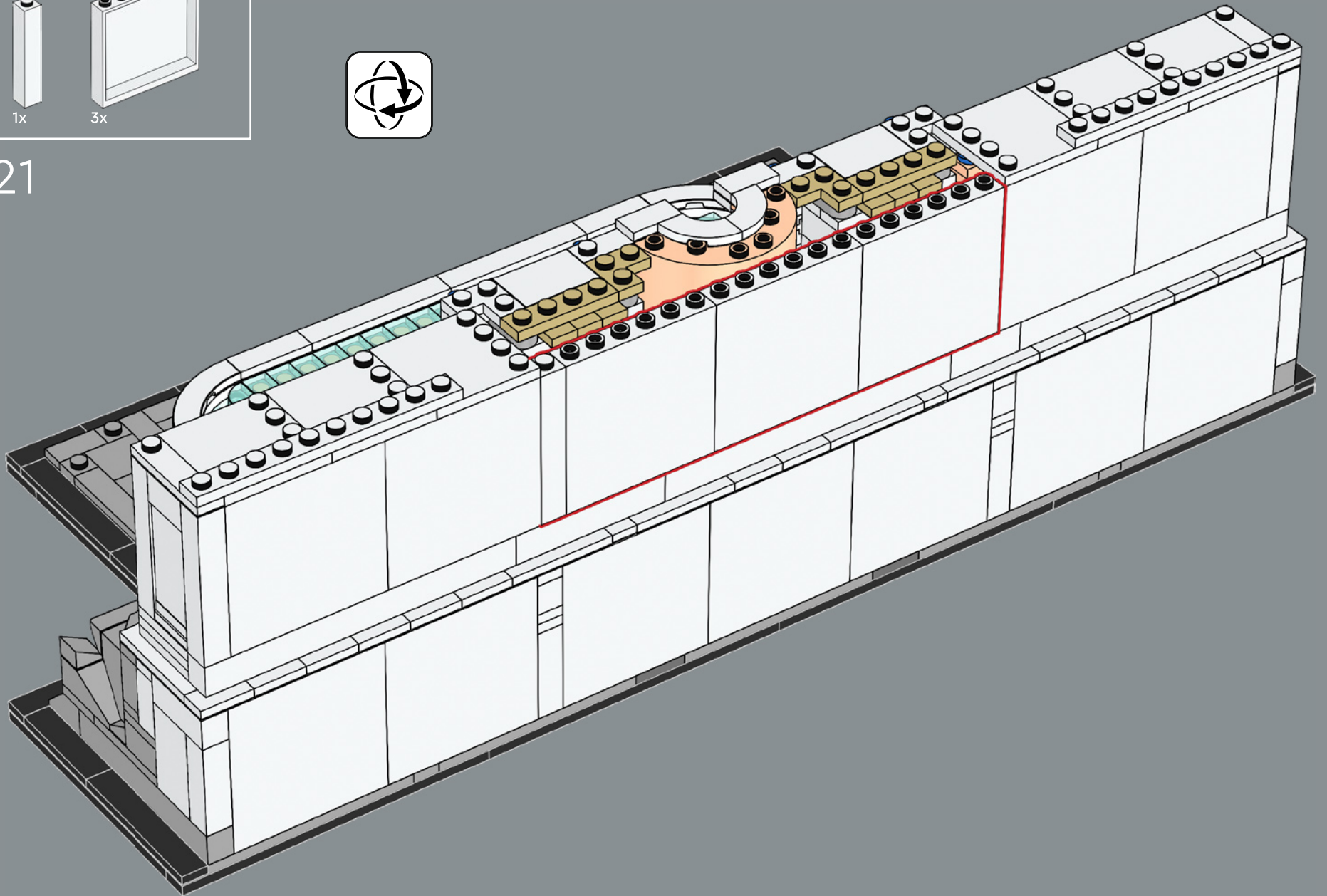

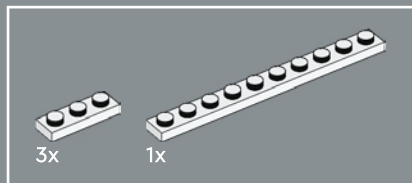

222

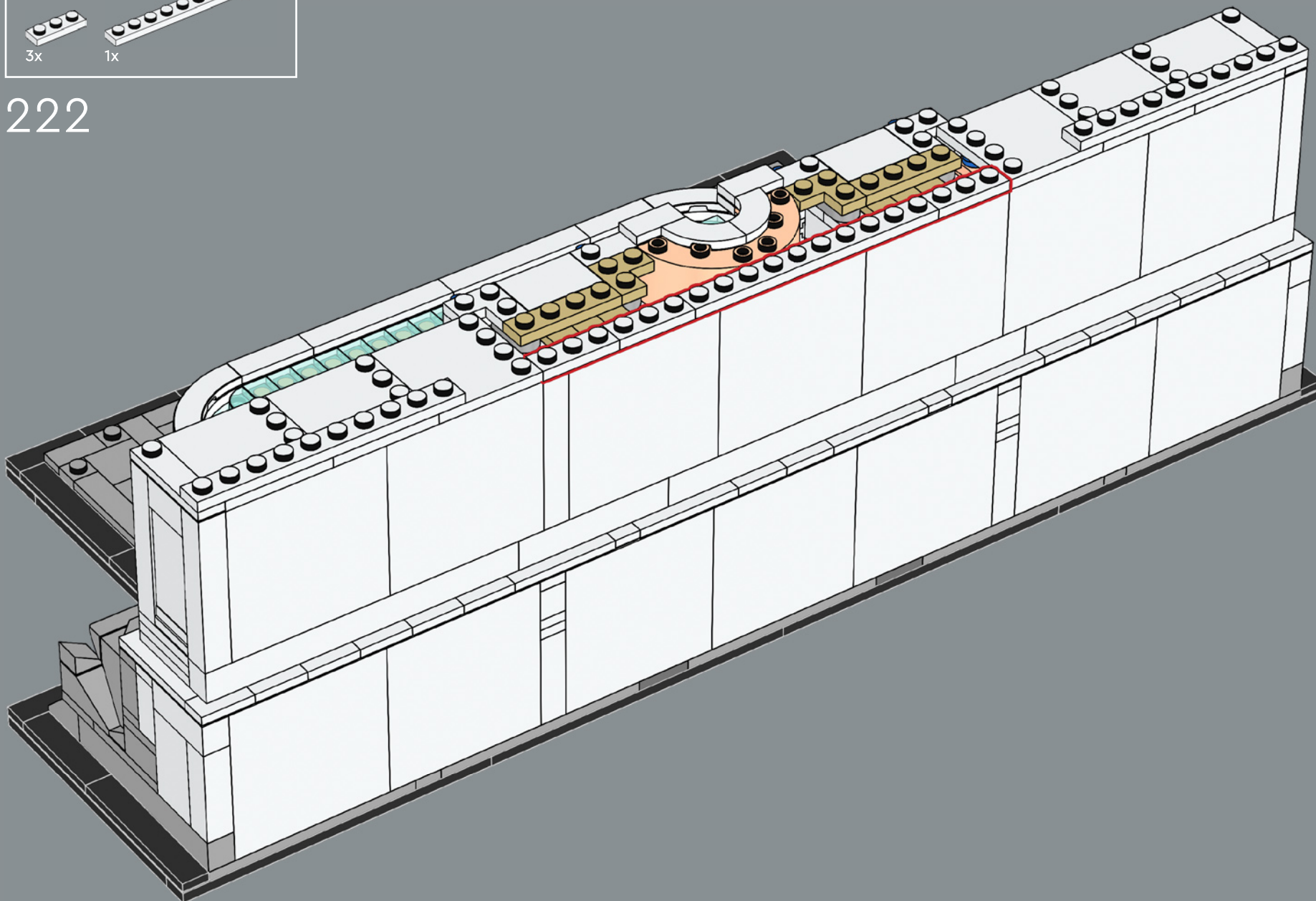

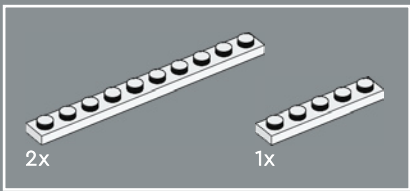

223

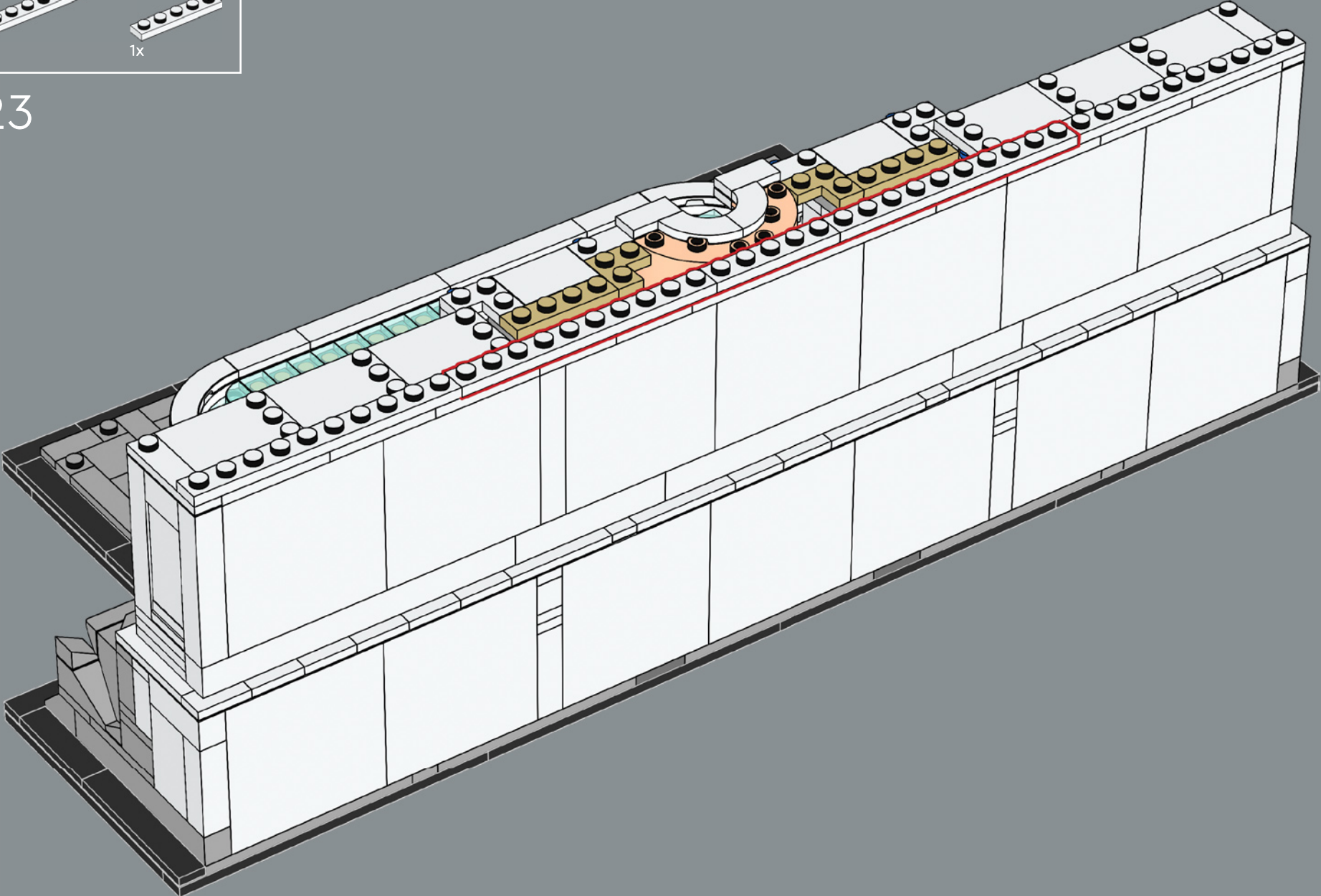

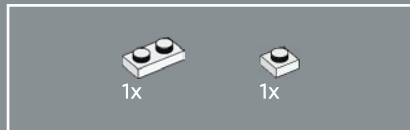
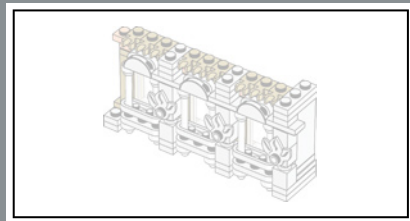

224

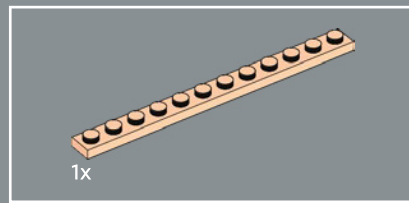
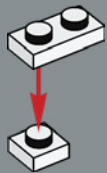

225

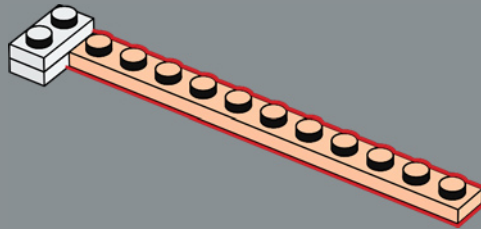

226

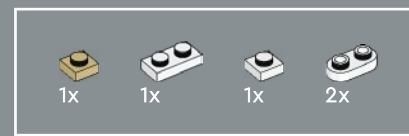
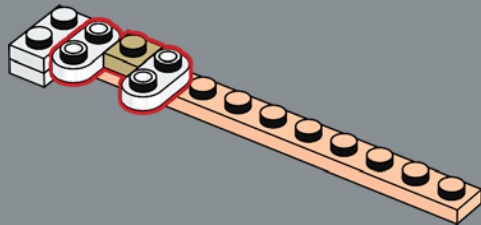

227

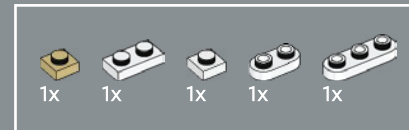
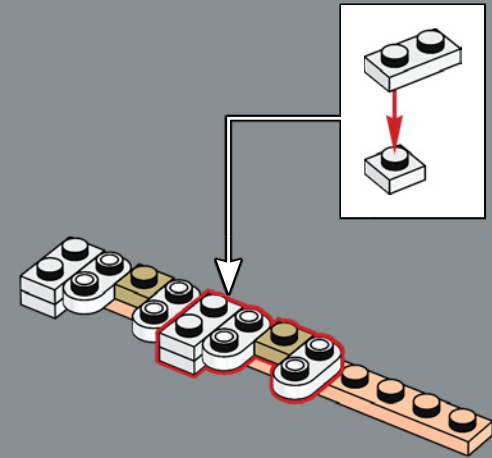

228

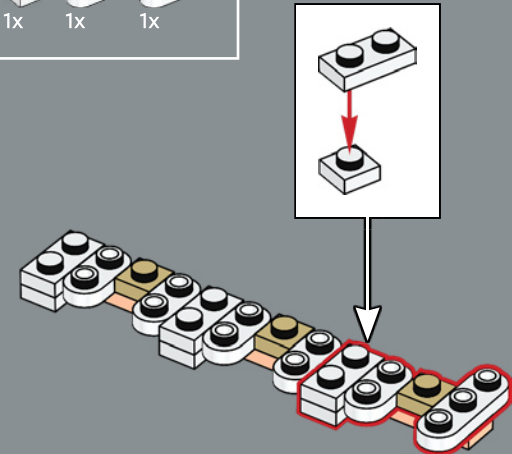

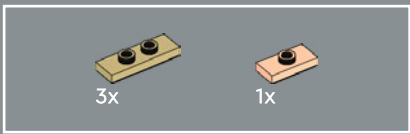

229

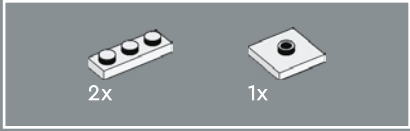
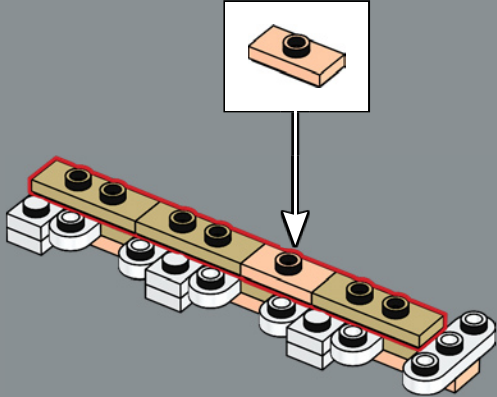

230

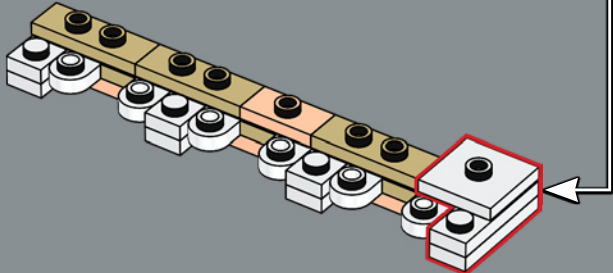
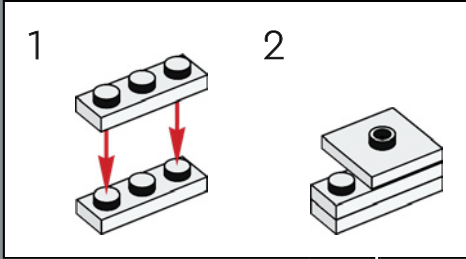

231

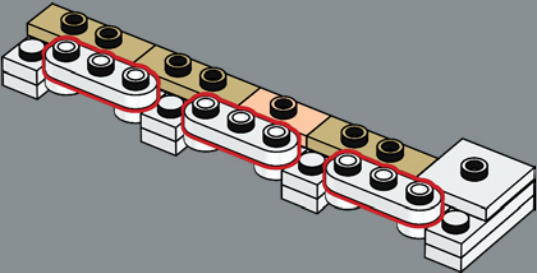

232

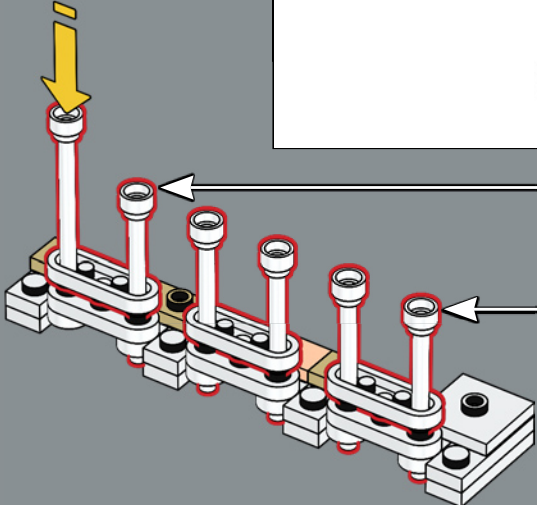
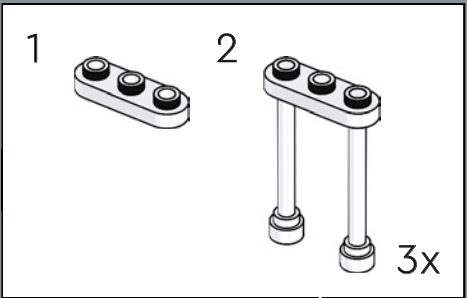

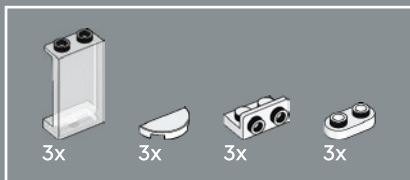

233

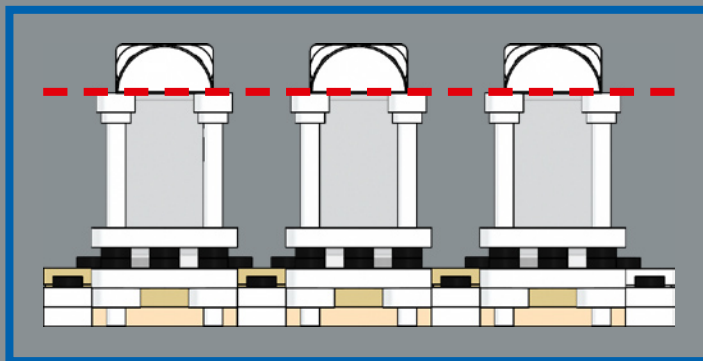

La « fenêtre » la plus à droite n'est en réalité qu'un mur peint de manière à s'harmoniser avec les 11 autres fenêtres.

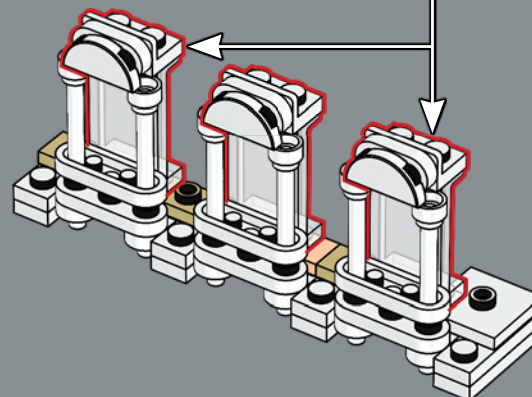
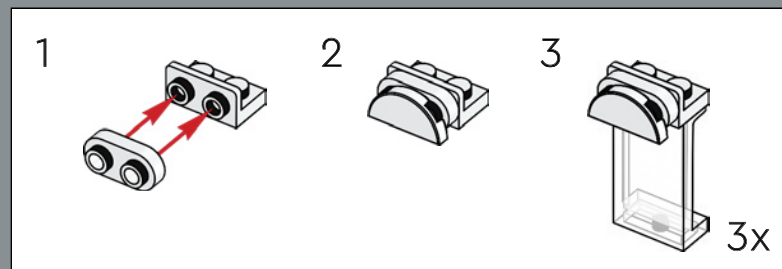

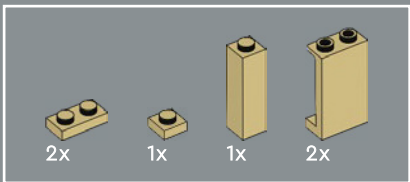

234

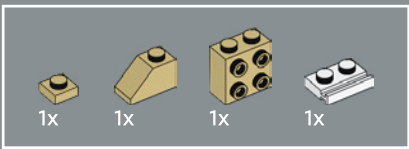
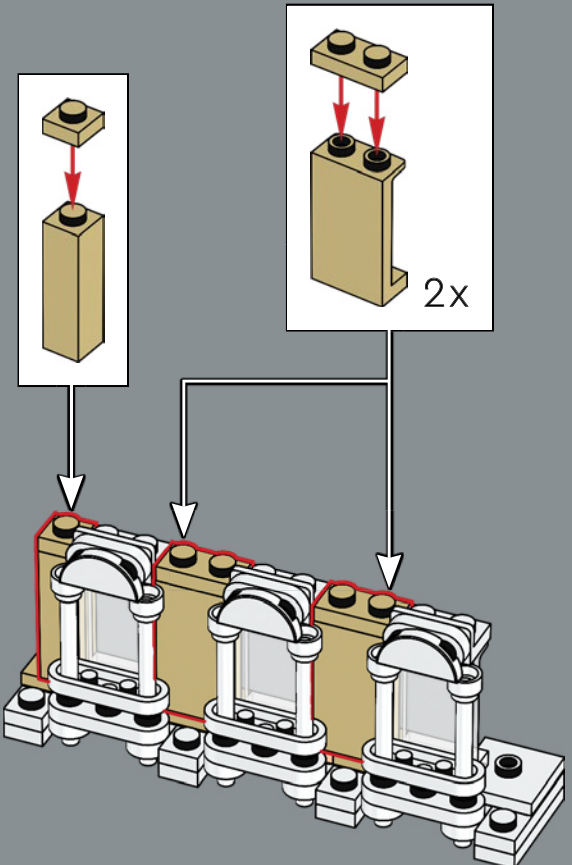

235

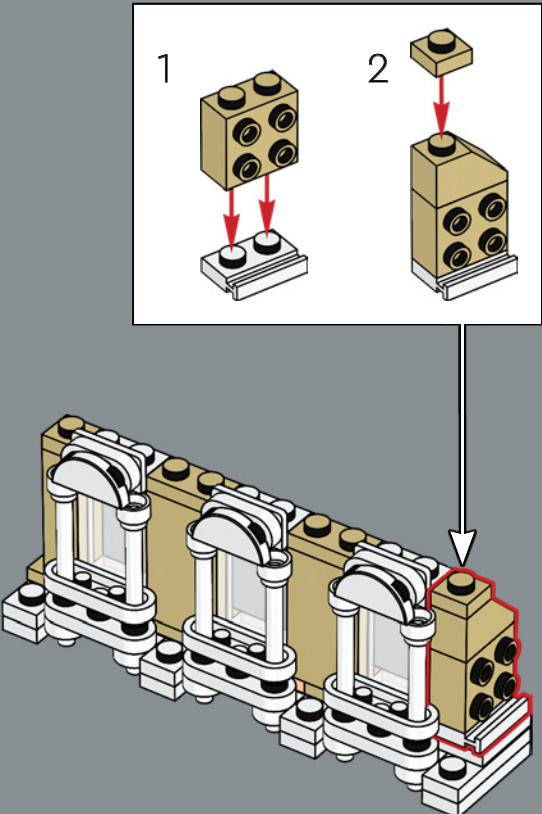

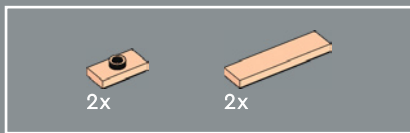

236

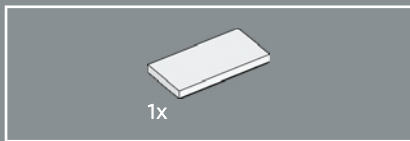
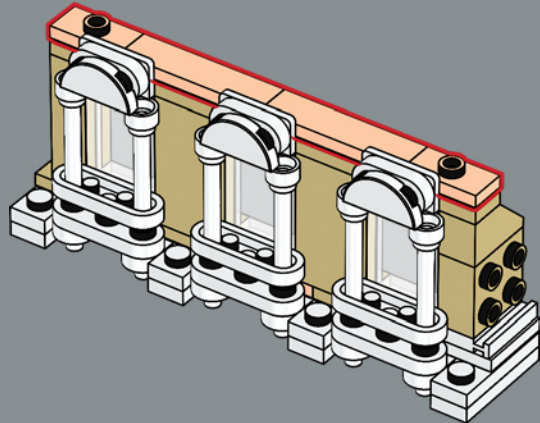

237

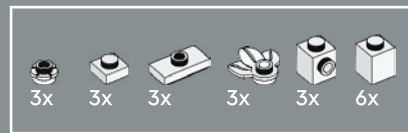
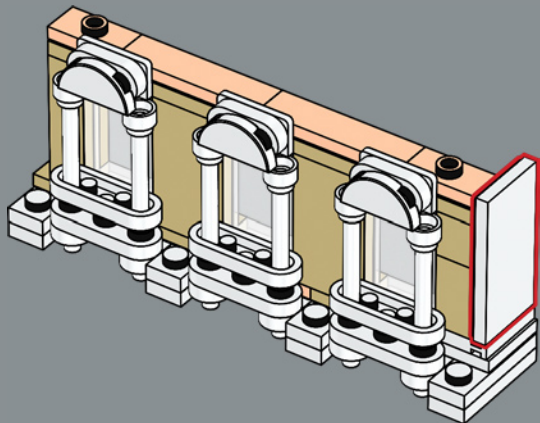

238

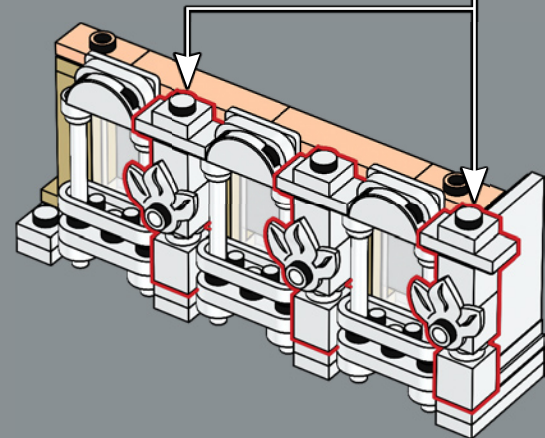
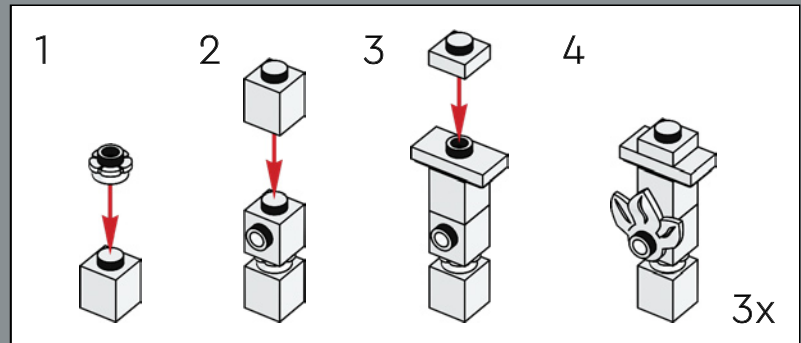

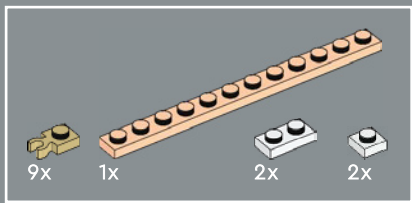

239

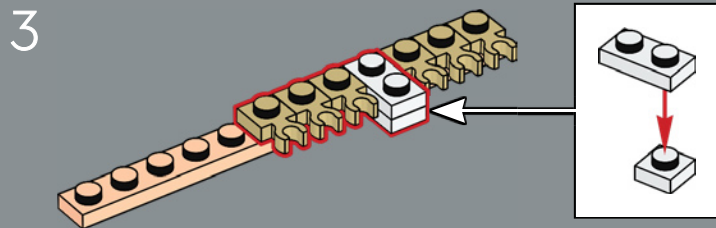
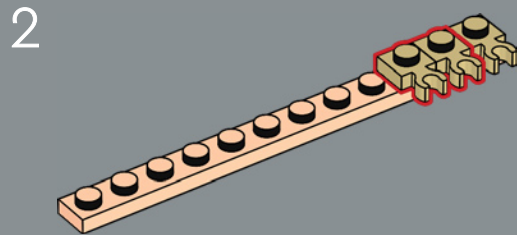
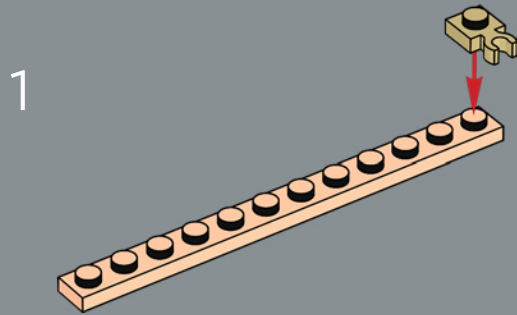

4

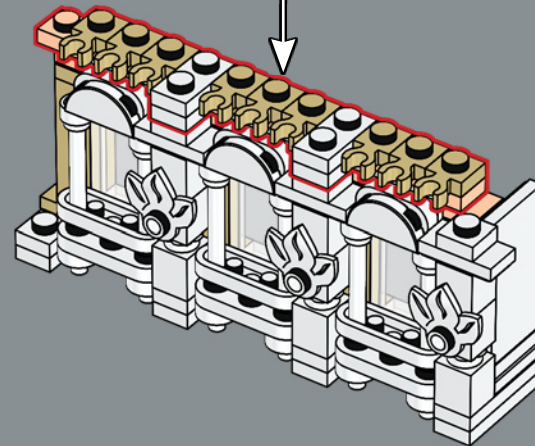
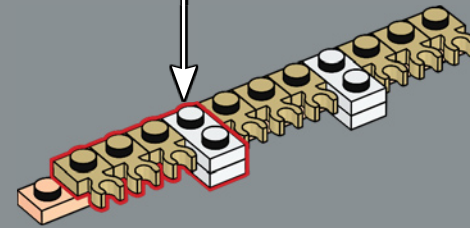
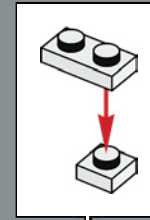

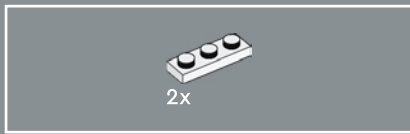

240

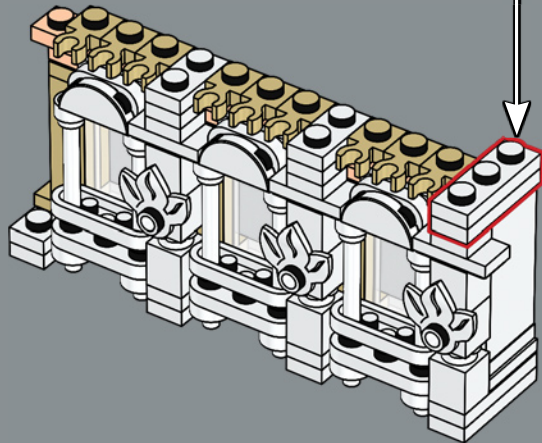
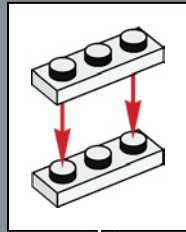

241

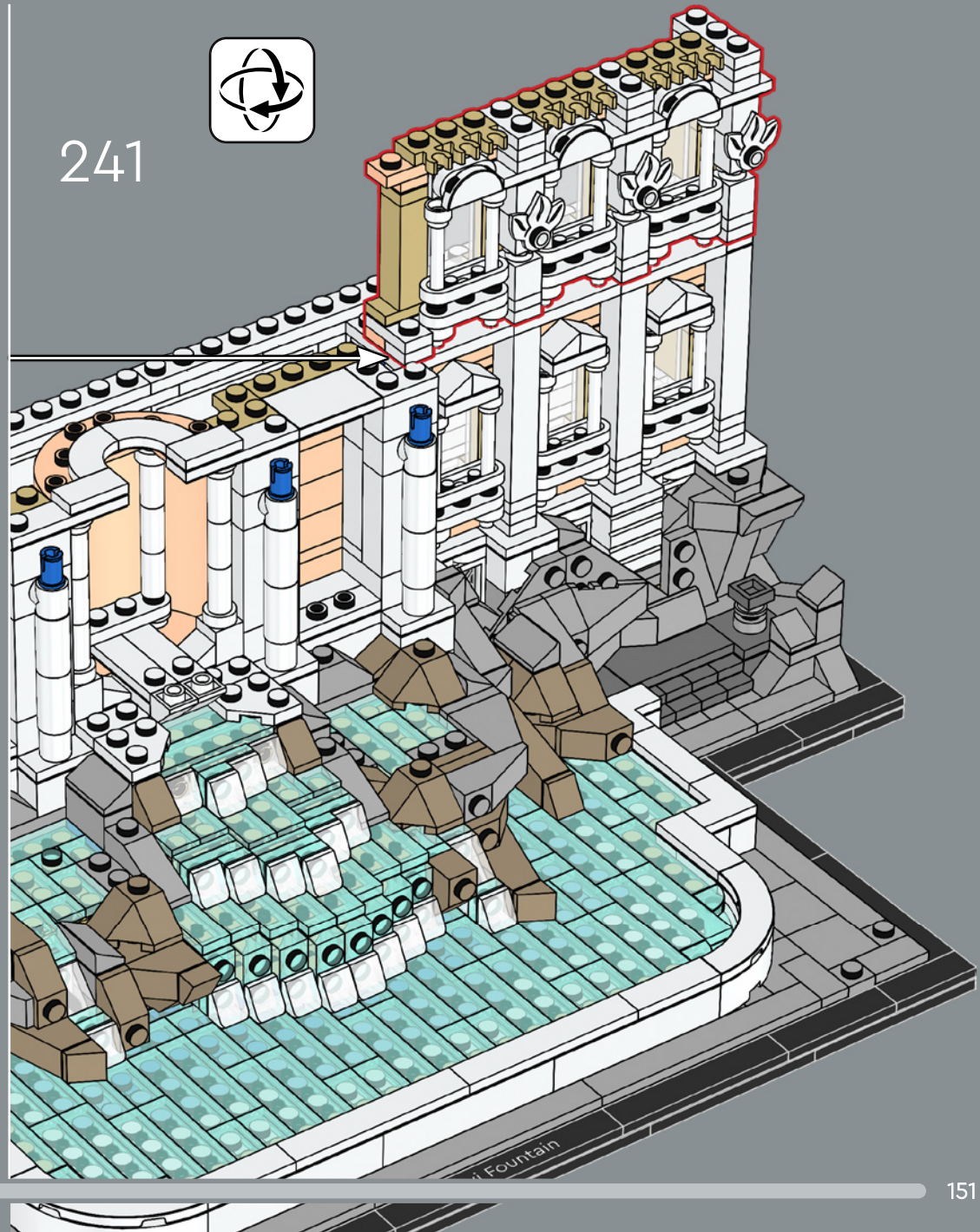

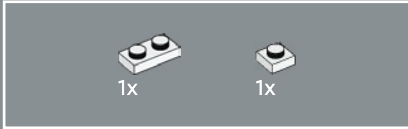
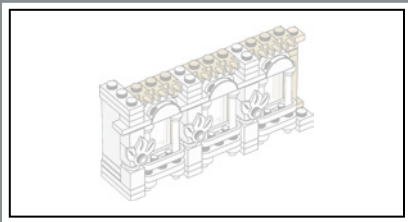

242

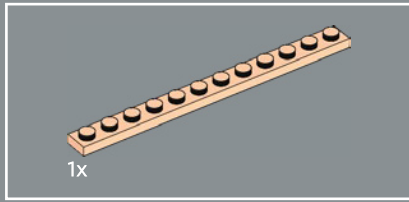
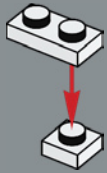

243

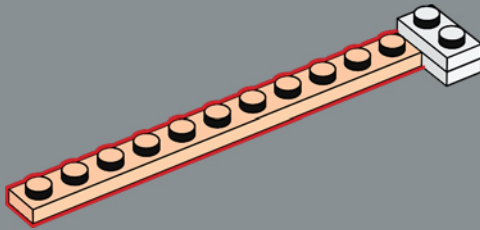

244

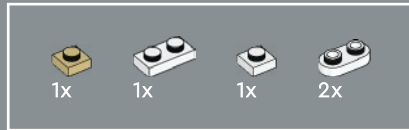
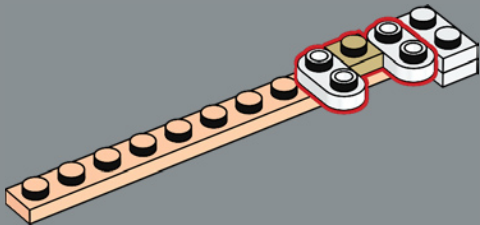

245

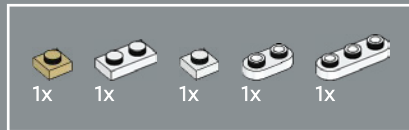
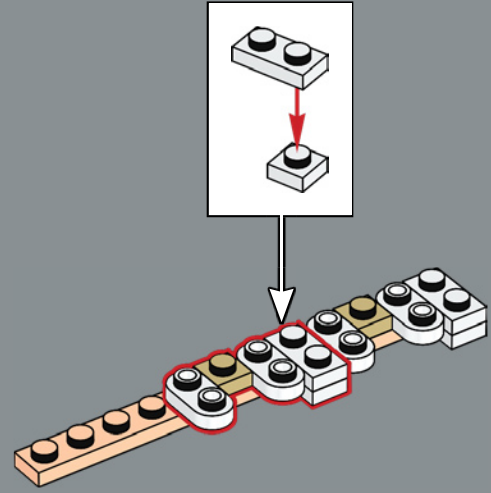

246

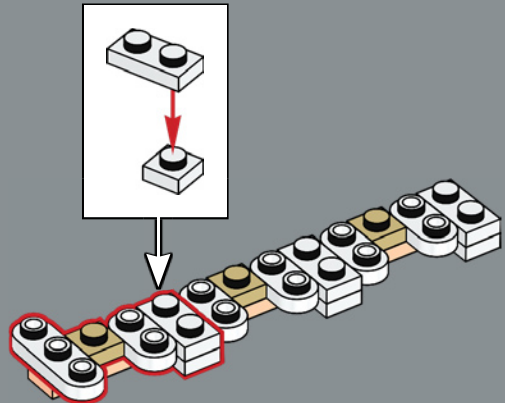

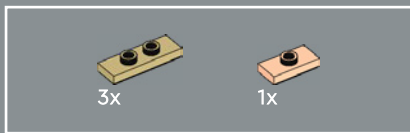

247

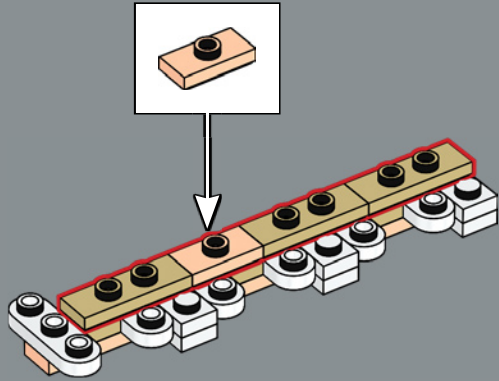

248

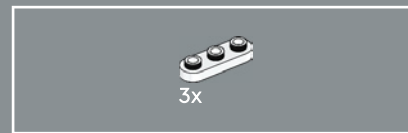
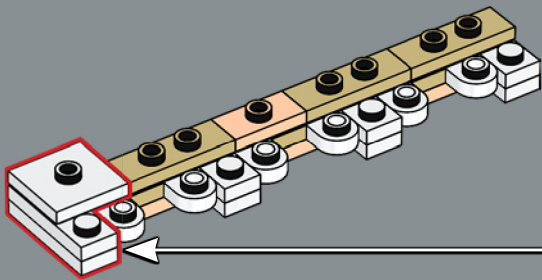
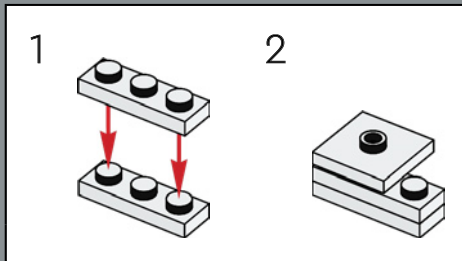

249

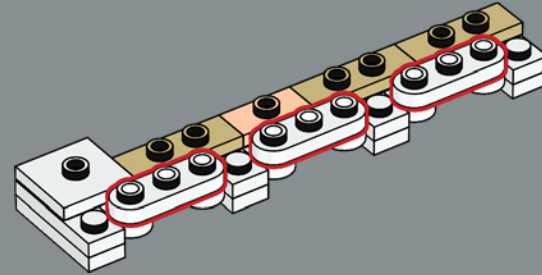

250

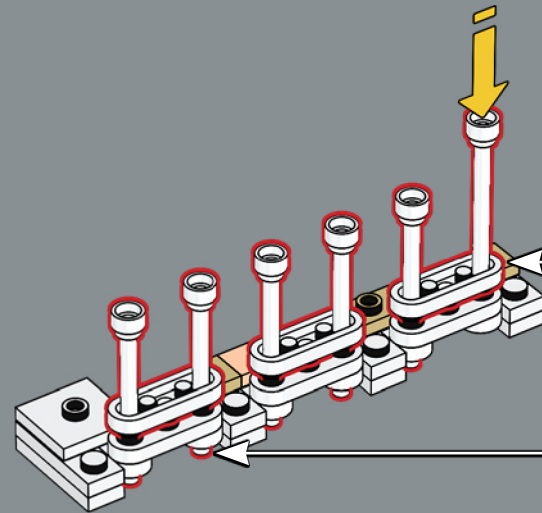
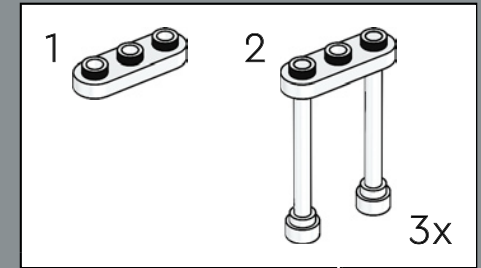

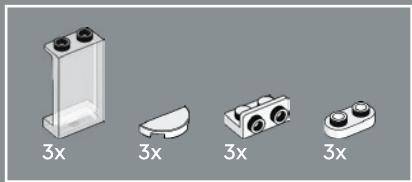

251

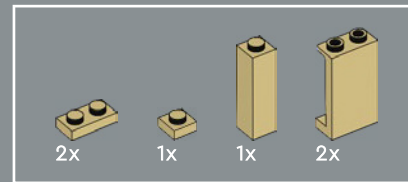
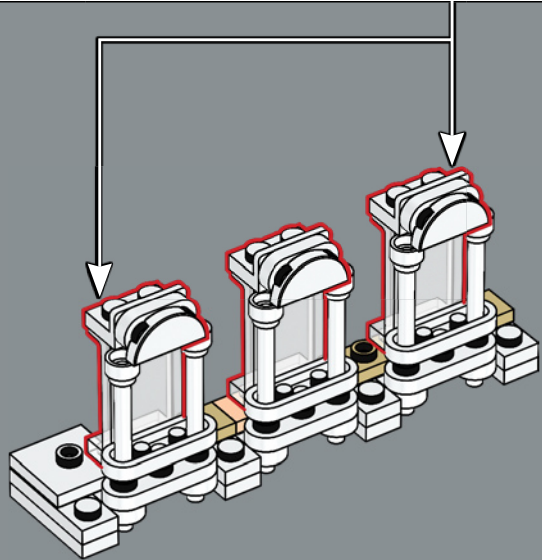
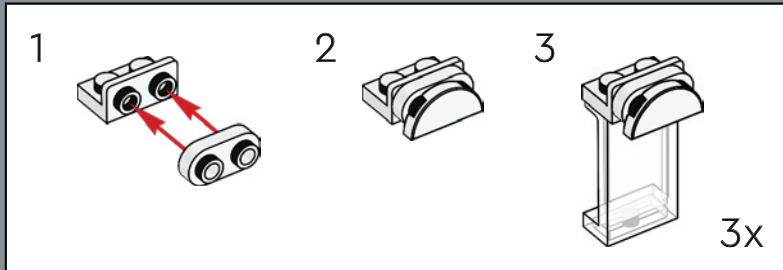
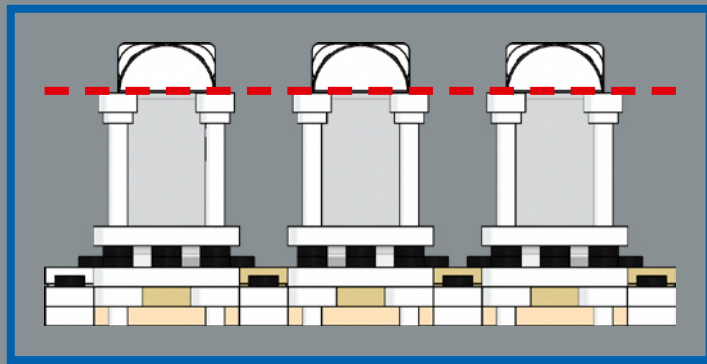

252

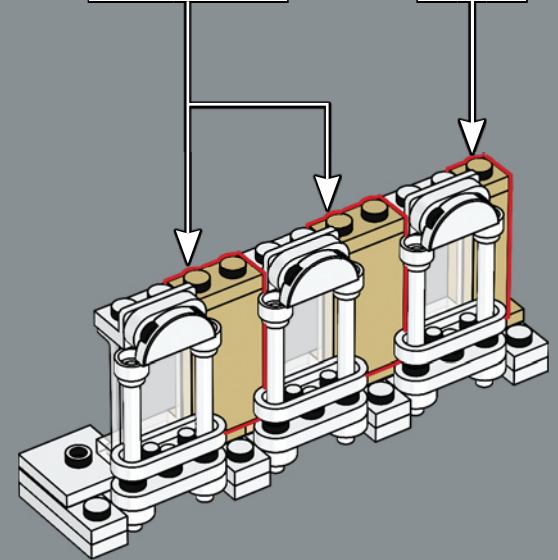
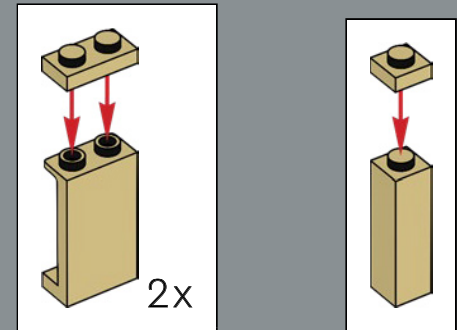

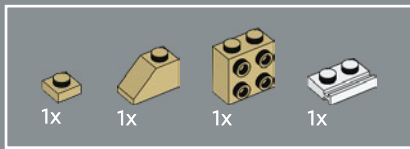

253

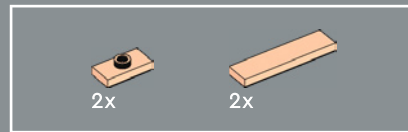
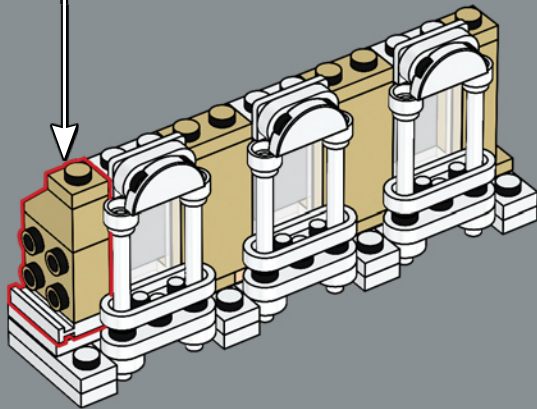
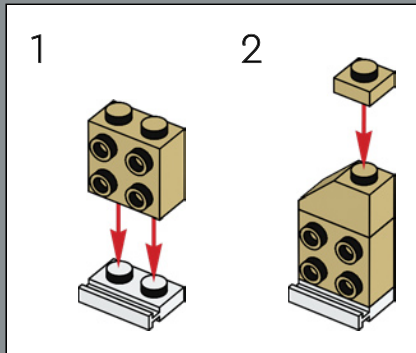

254

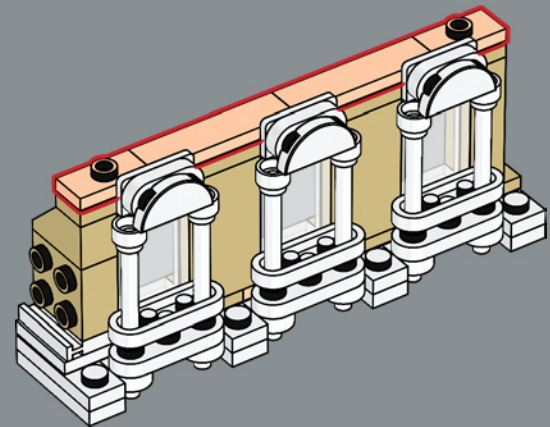

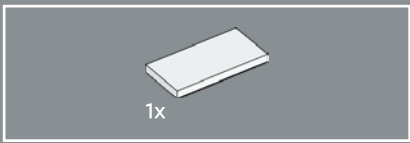

255

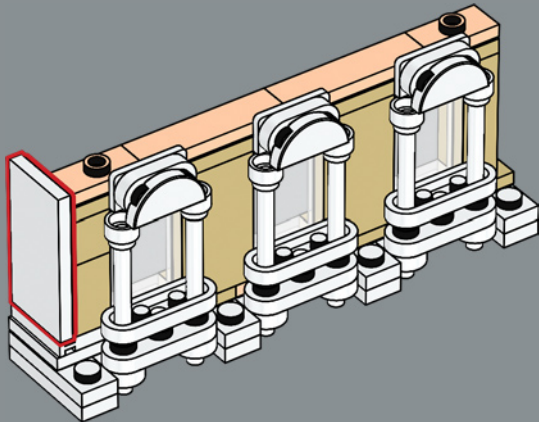

256

Les éléments végétaux LEGO® utilisés ici permettent de créer les chapiteaux des colonnes corinthiennes.

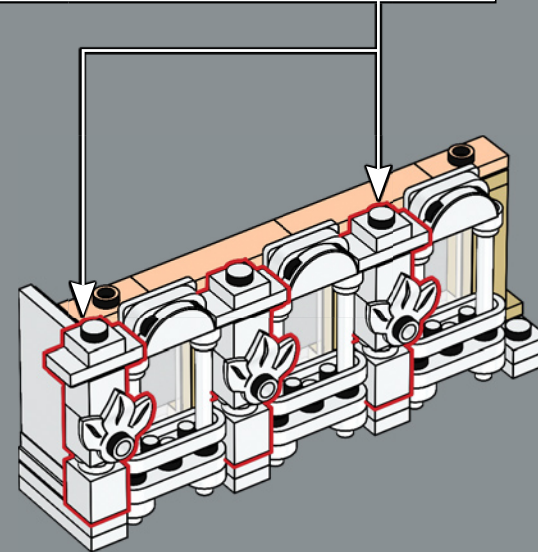
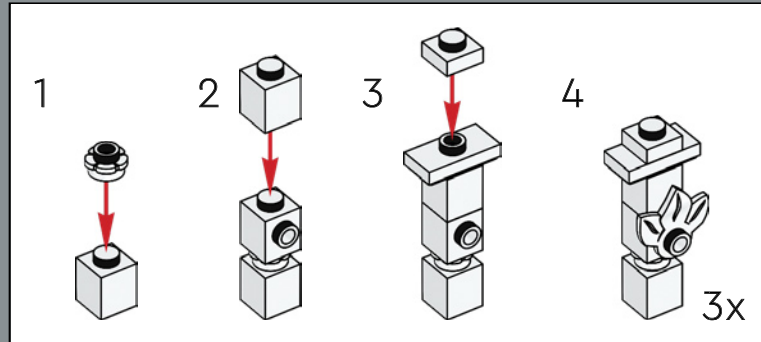

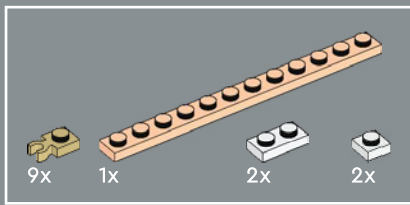

257

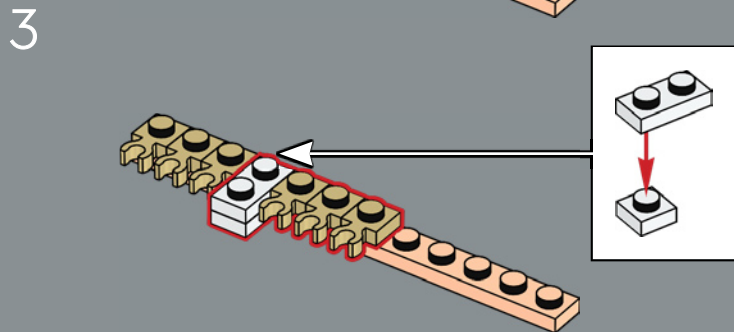
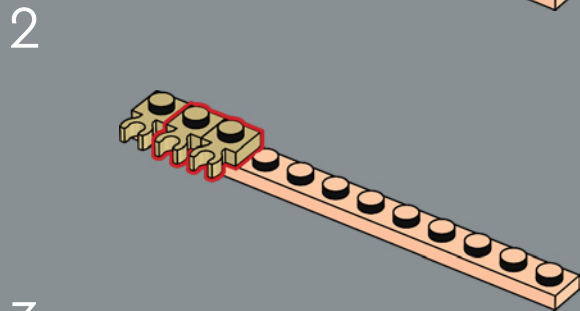
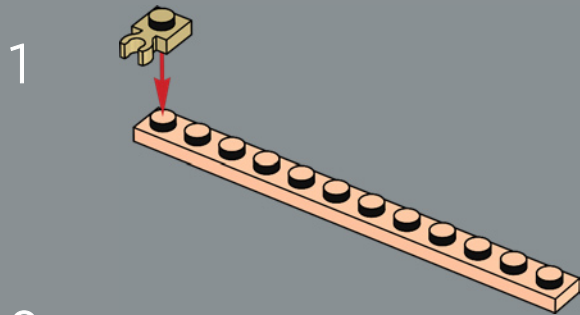

4

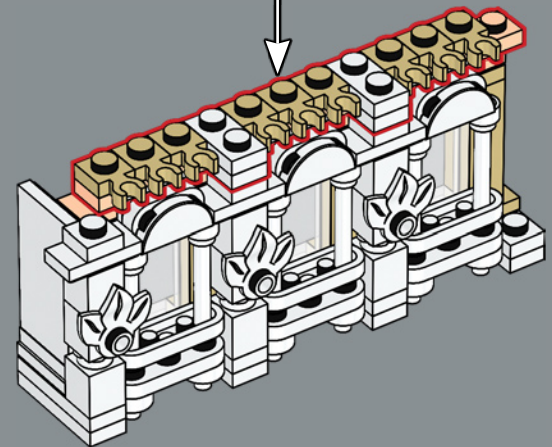
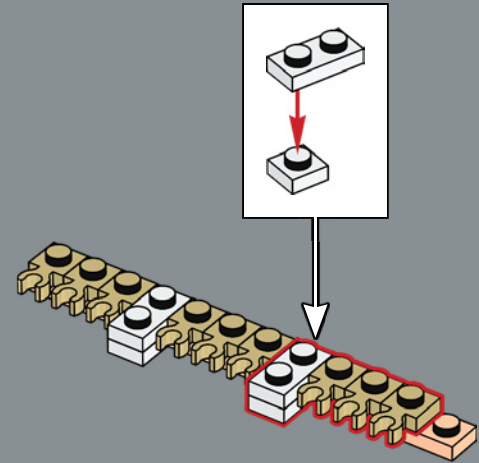

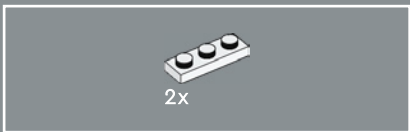

258

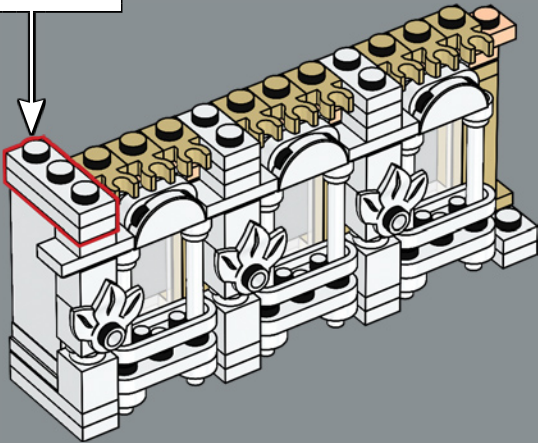
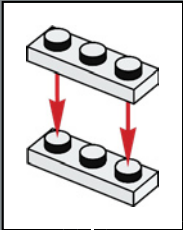

259

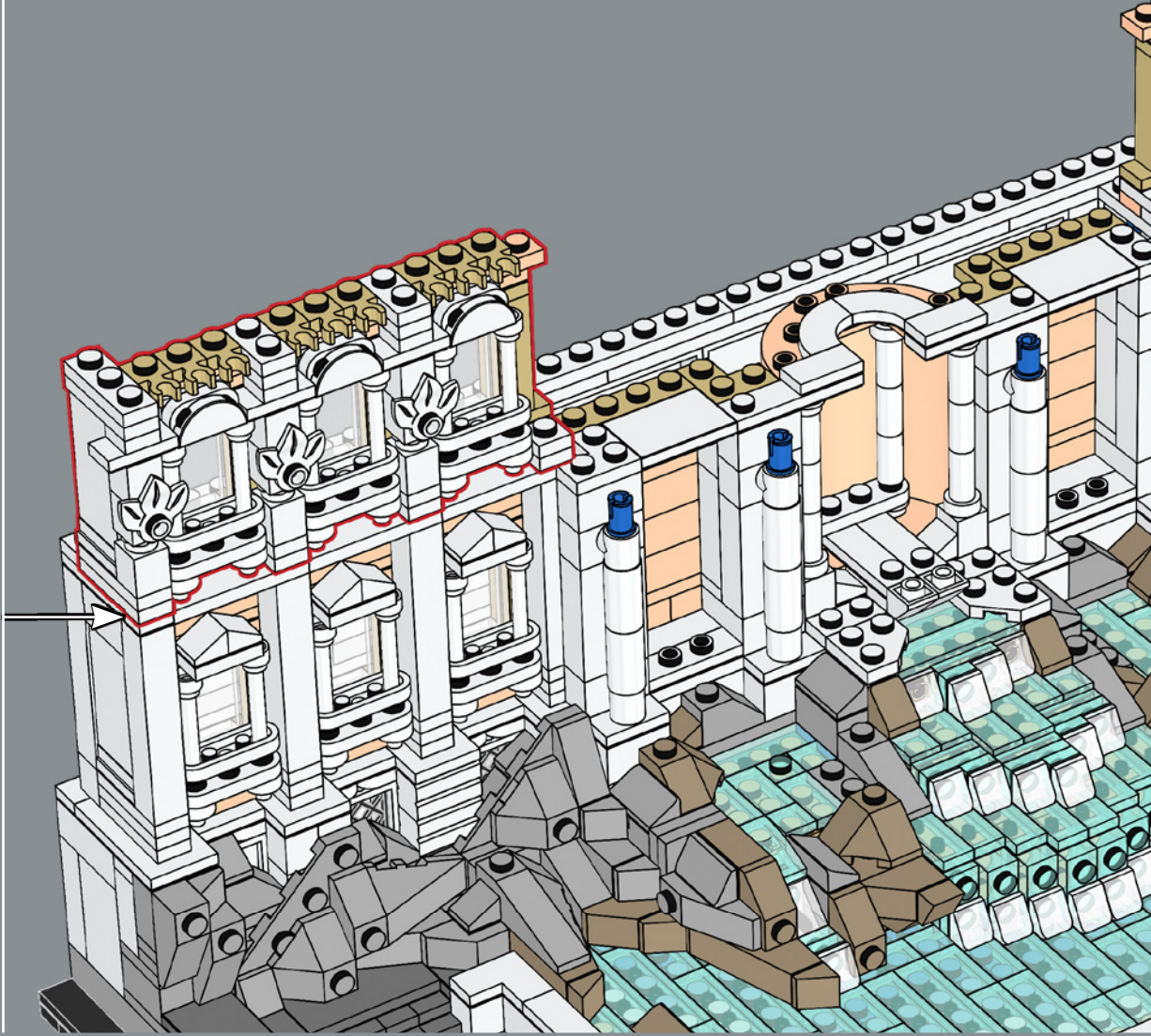

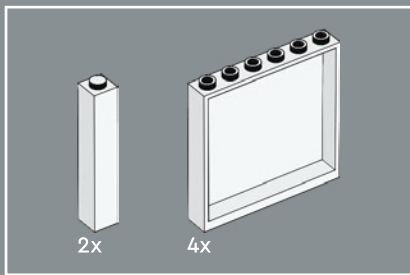

260

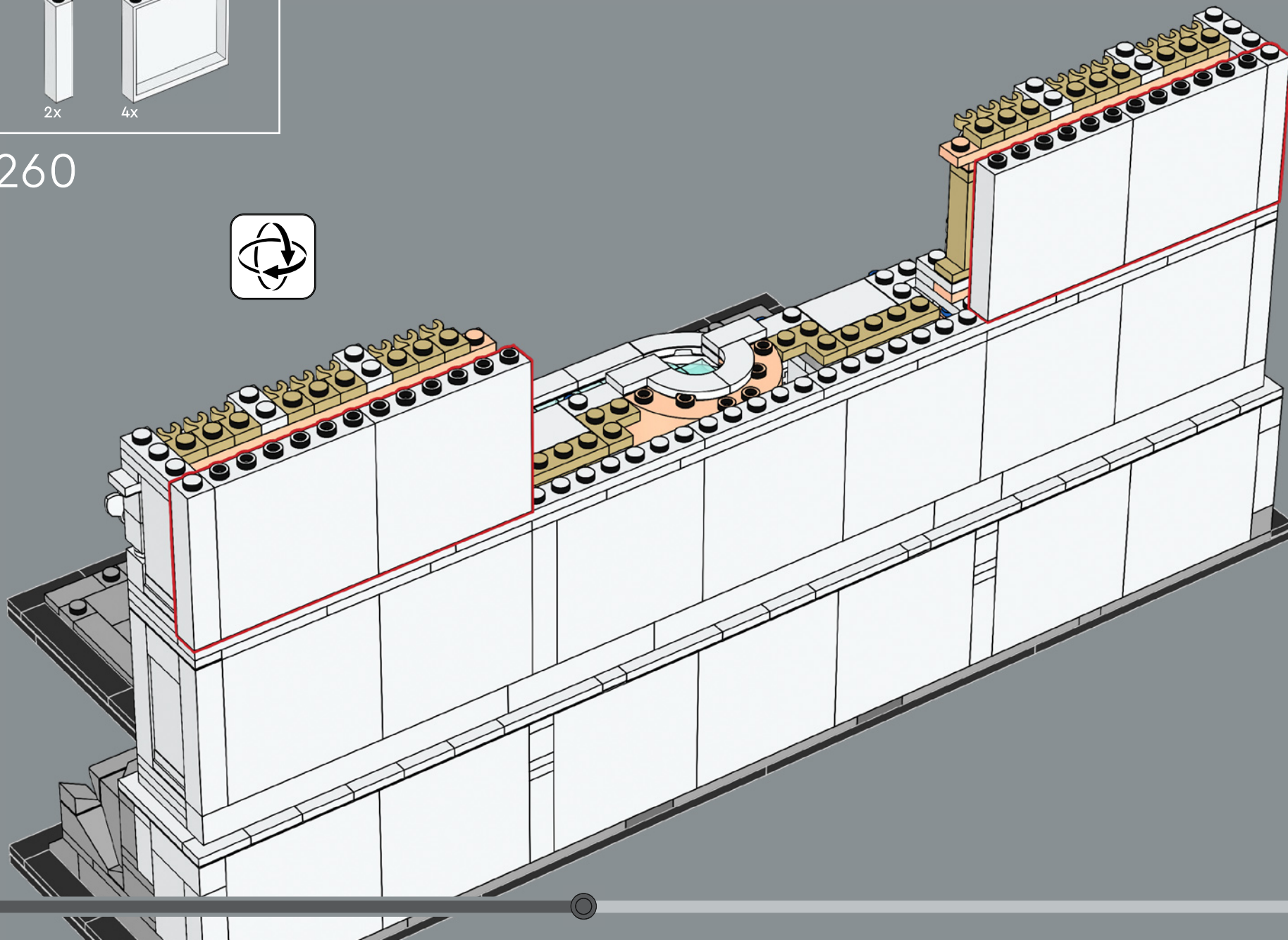



261

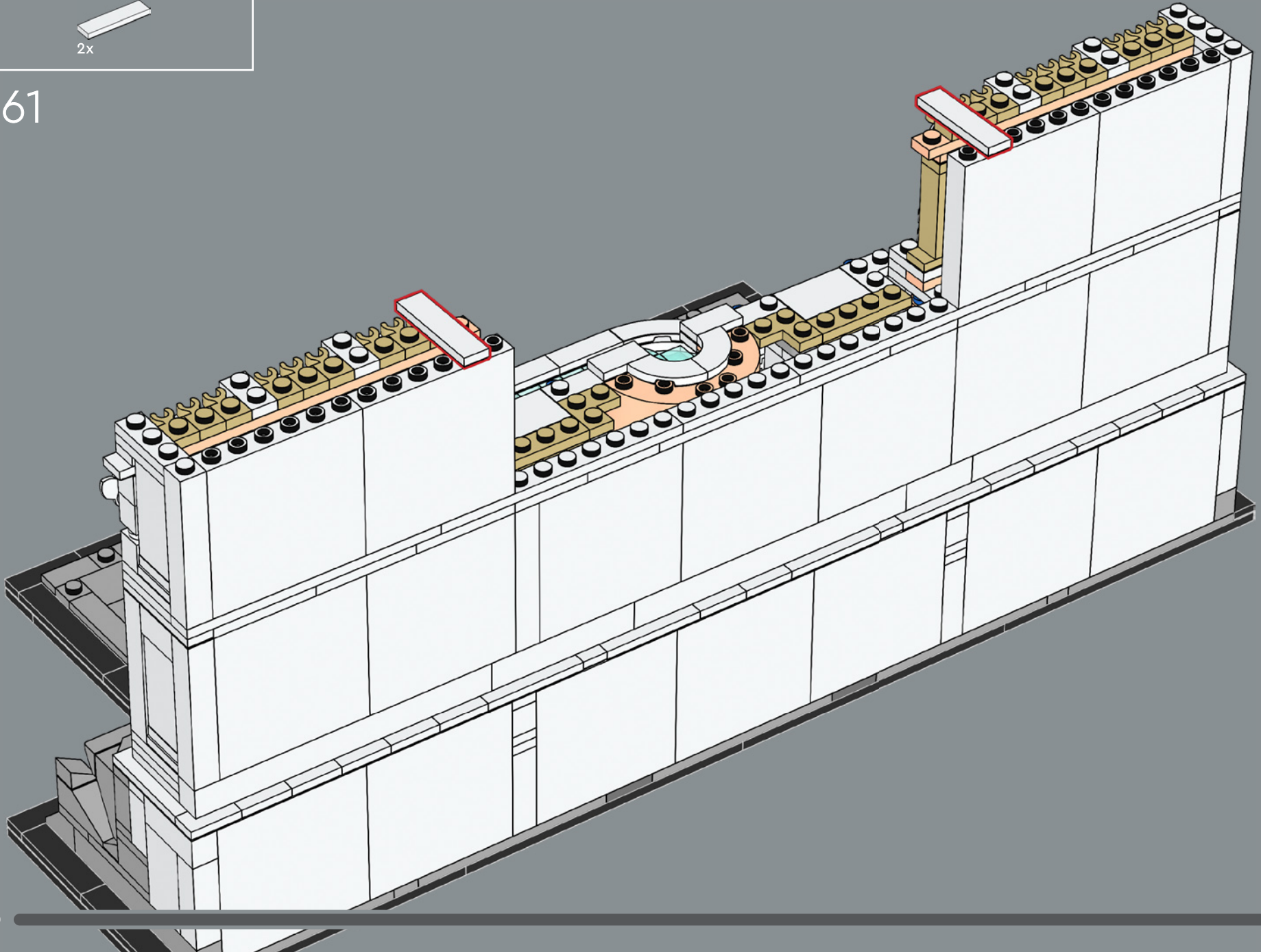

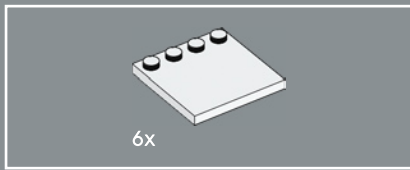

262

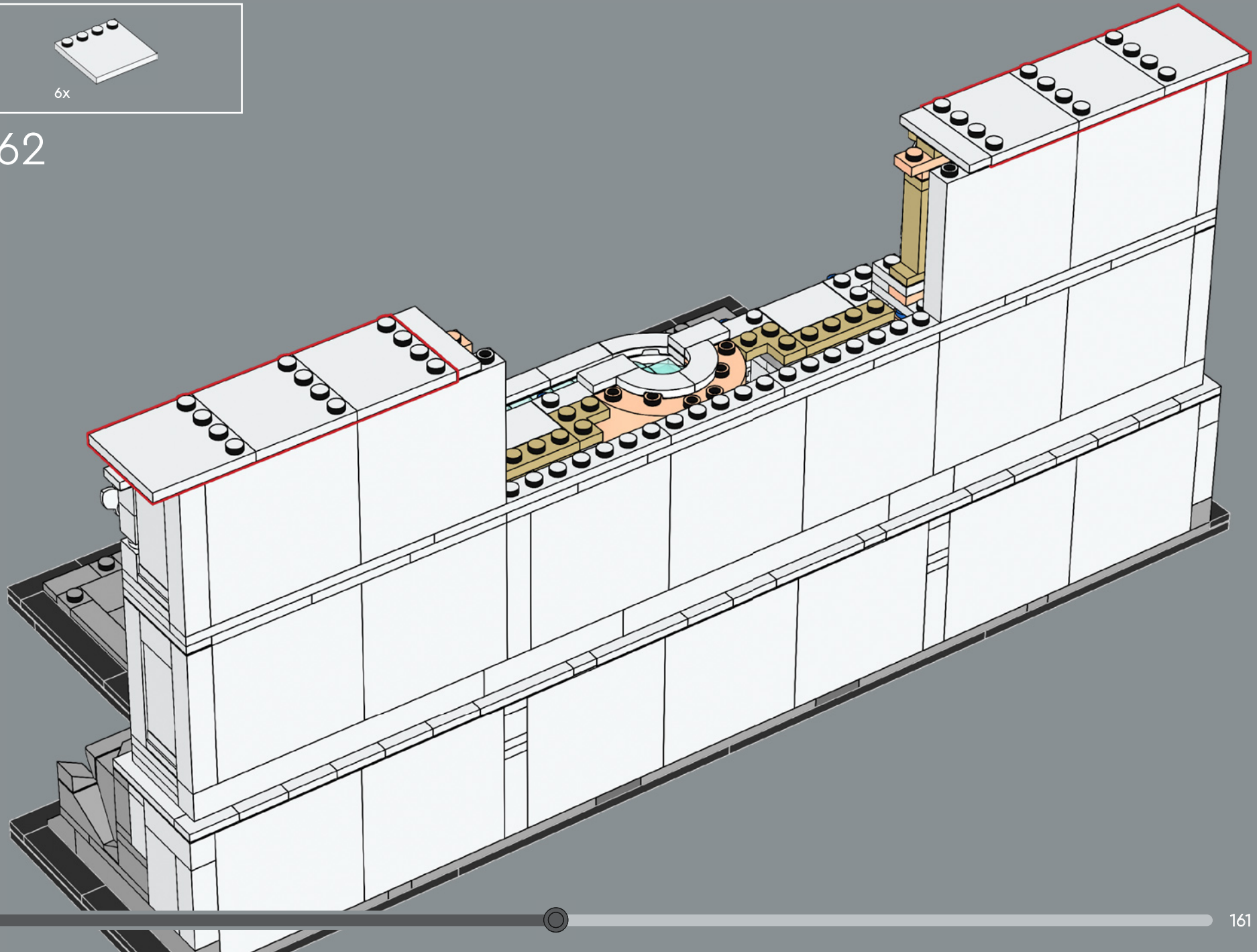

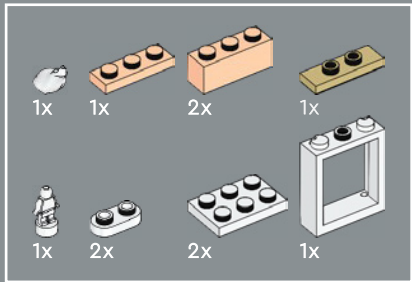

263

1

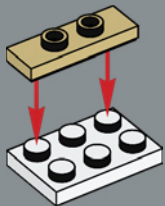

2

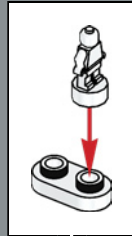
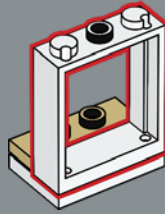

3

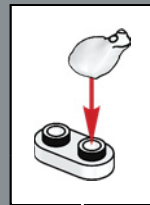
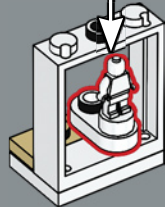

4



1

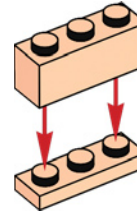

2

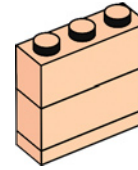

5



6



Les bas-reliefs de gauche et de droite comprennent un personnage debout et un personnage agenouillé, représentés ici par un trophée en forme de minifigurine LEGO® et une grenouille.

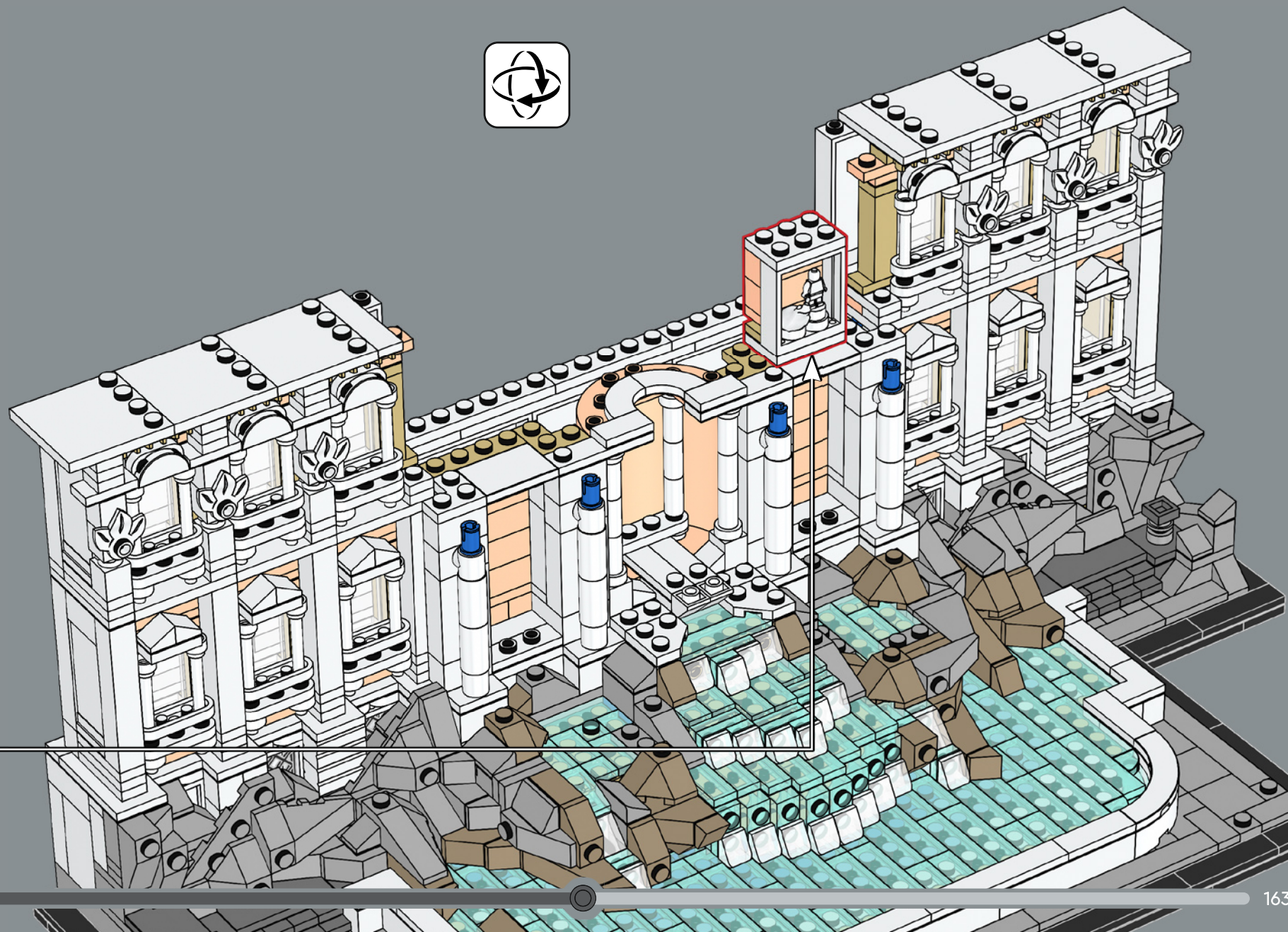

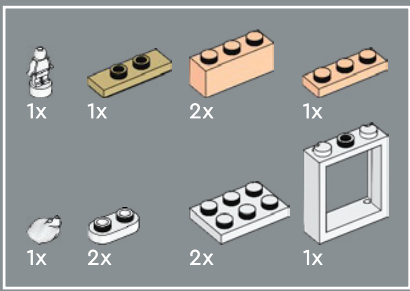

264

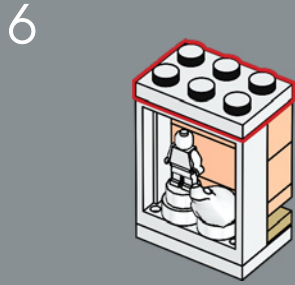
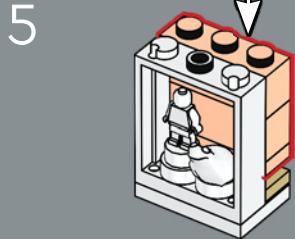
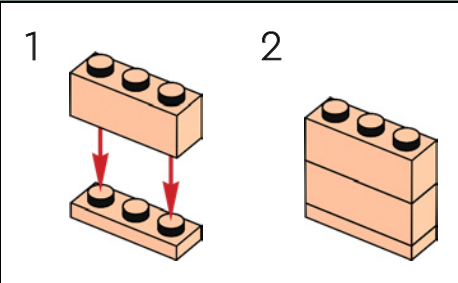
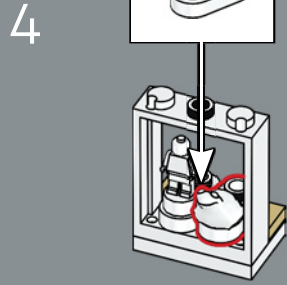
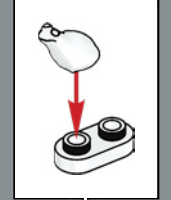
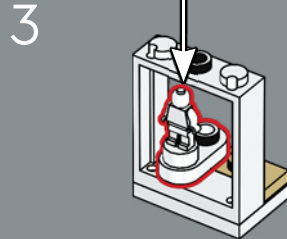
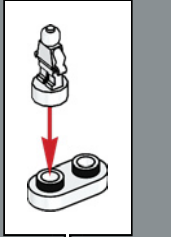
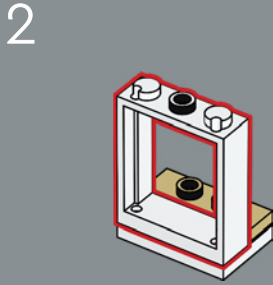
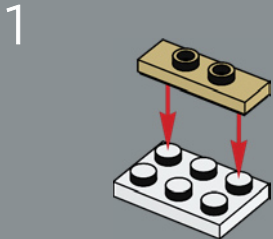

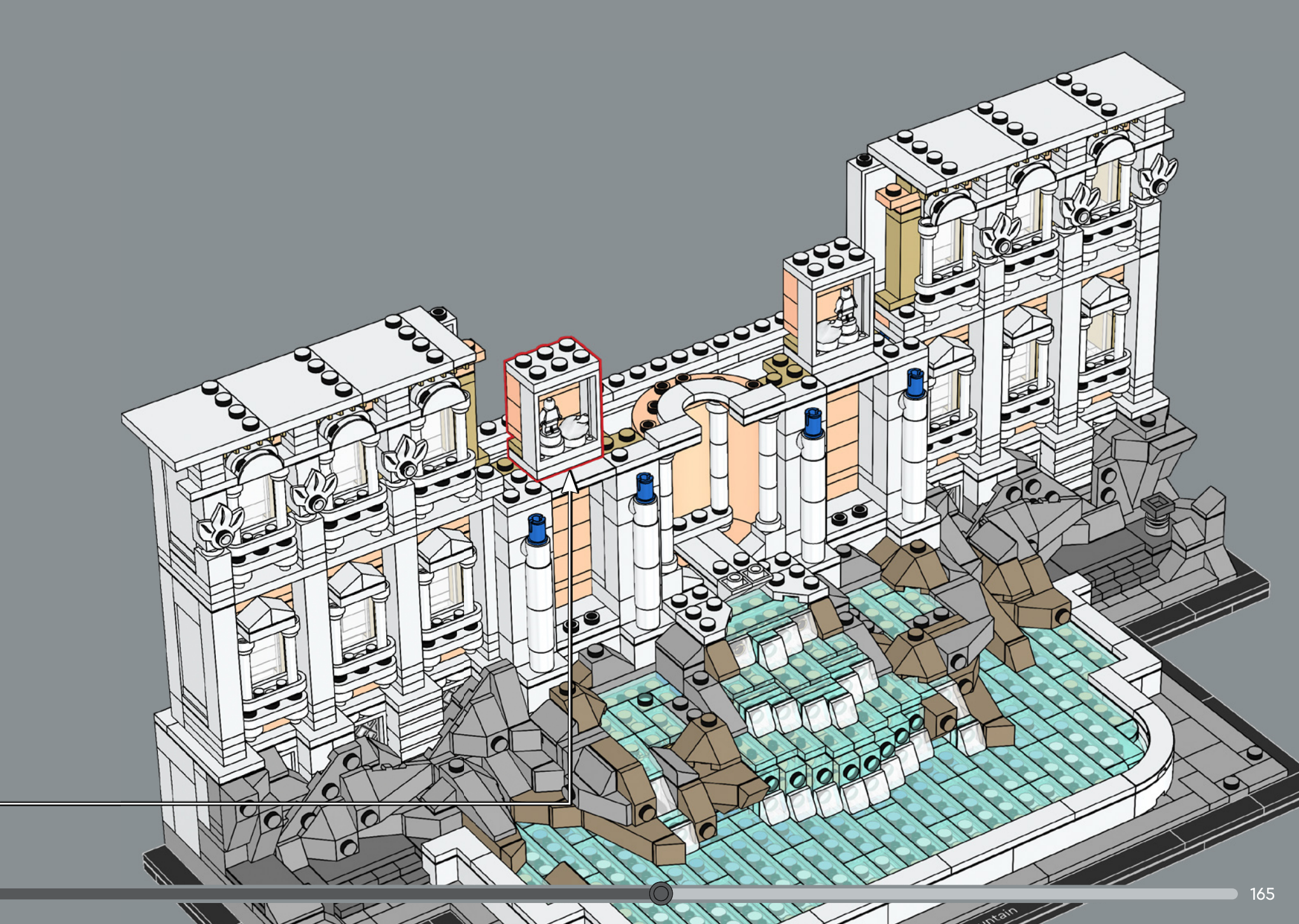

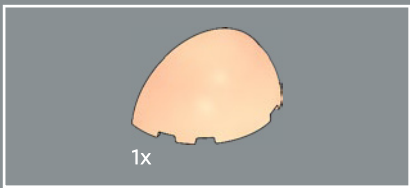

265

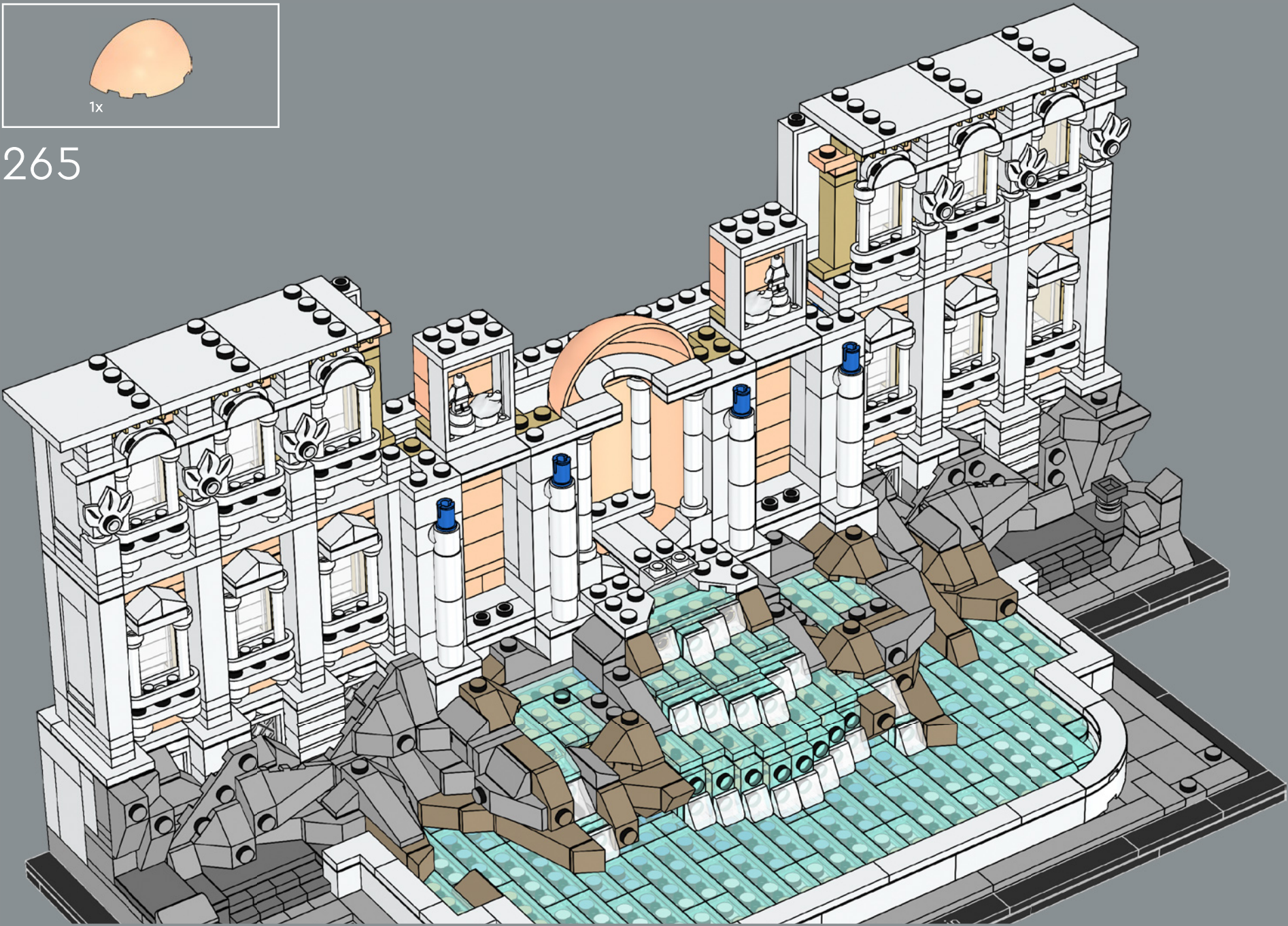

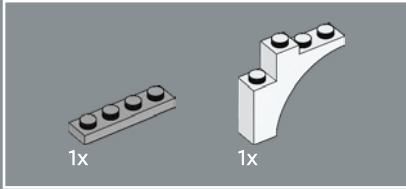
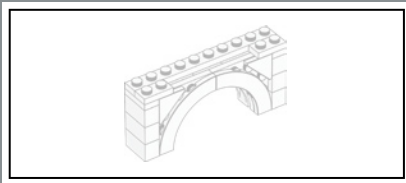

266

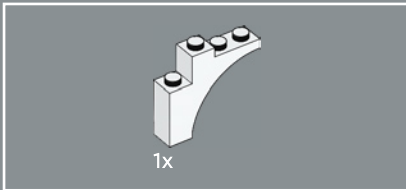
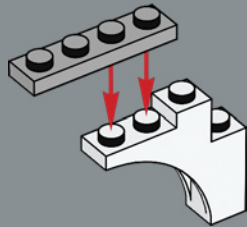

267

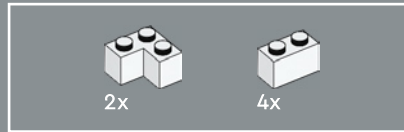
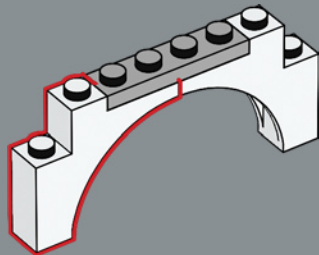

268

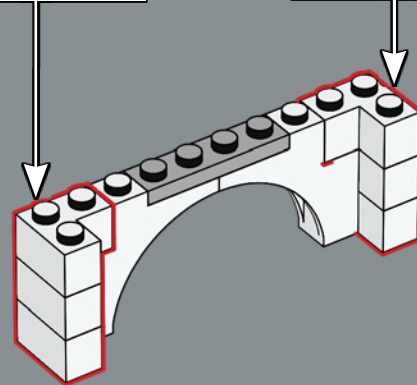
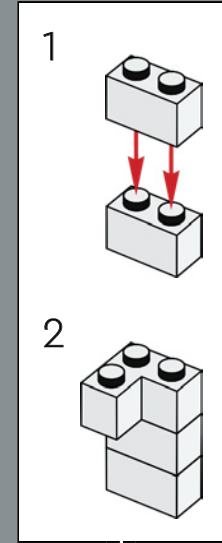
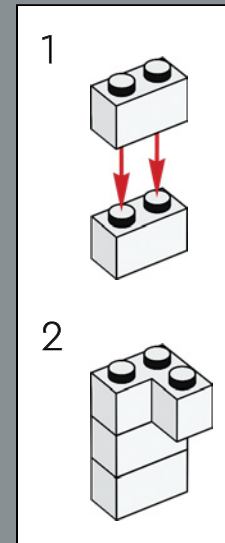

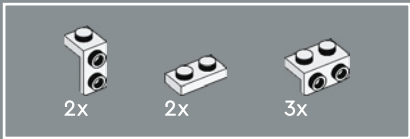

269

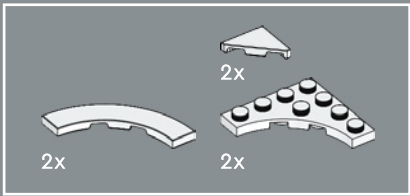
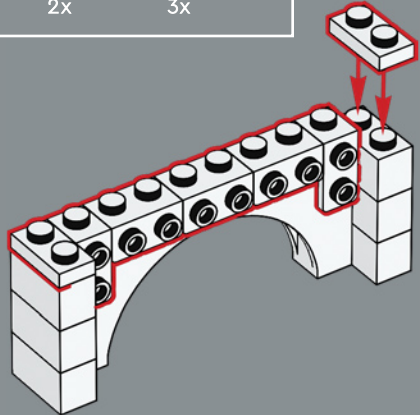

270

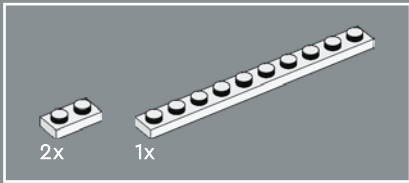
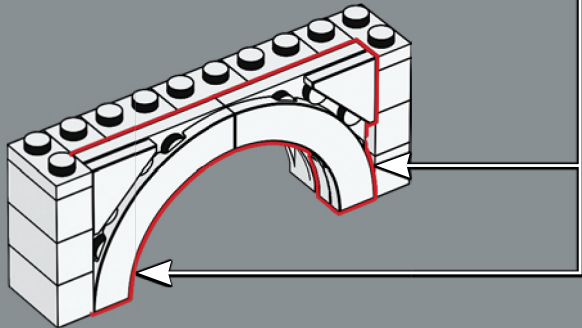
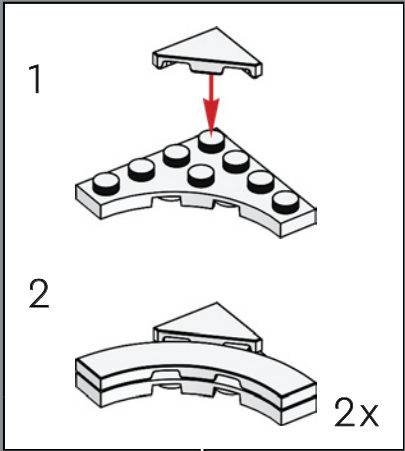

271

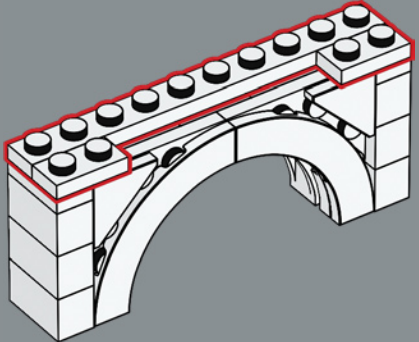

272

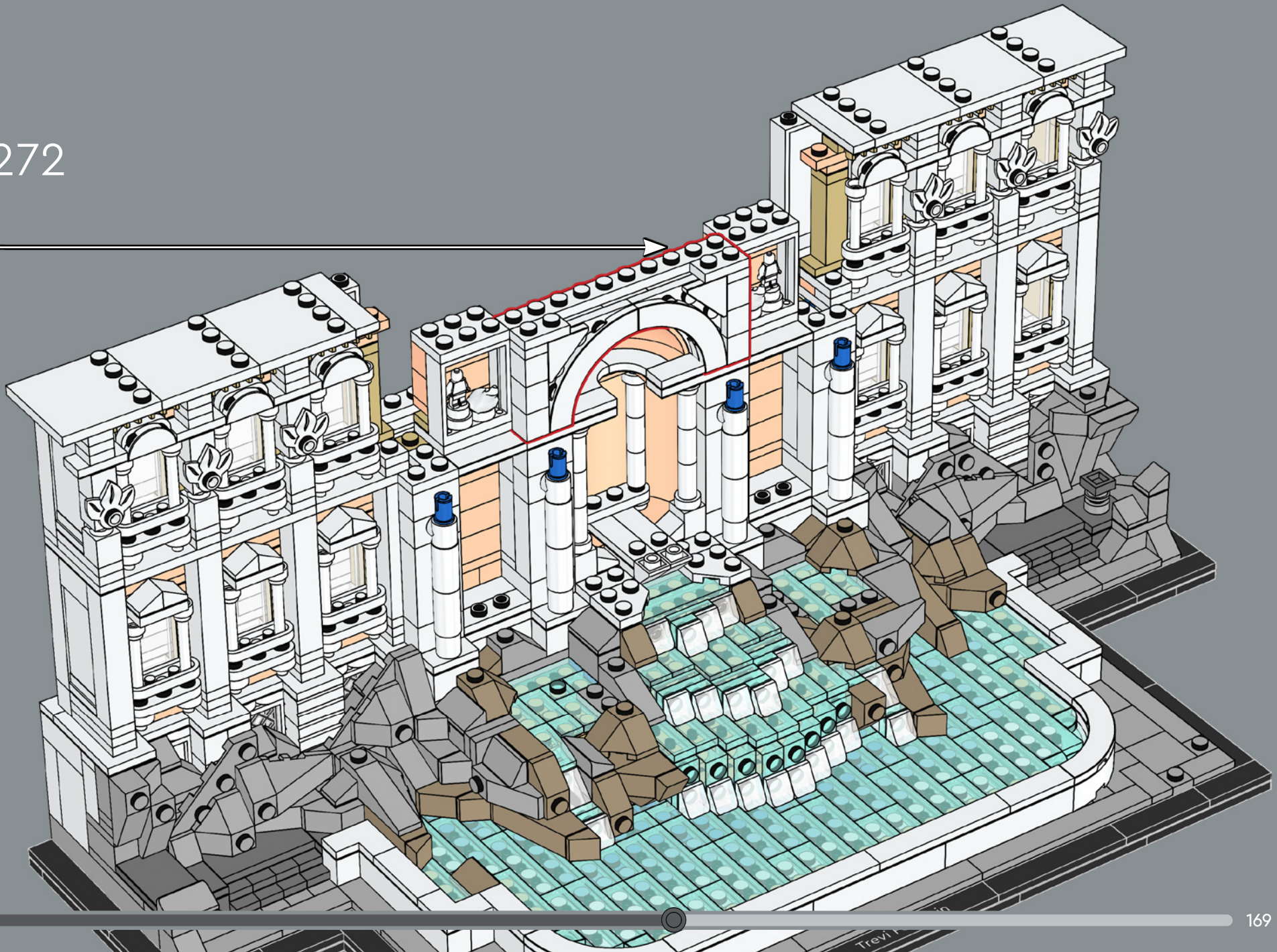

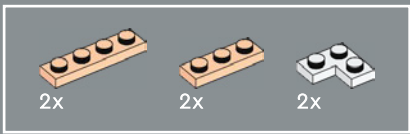

273

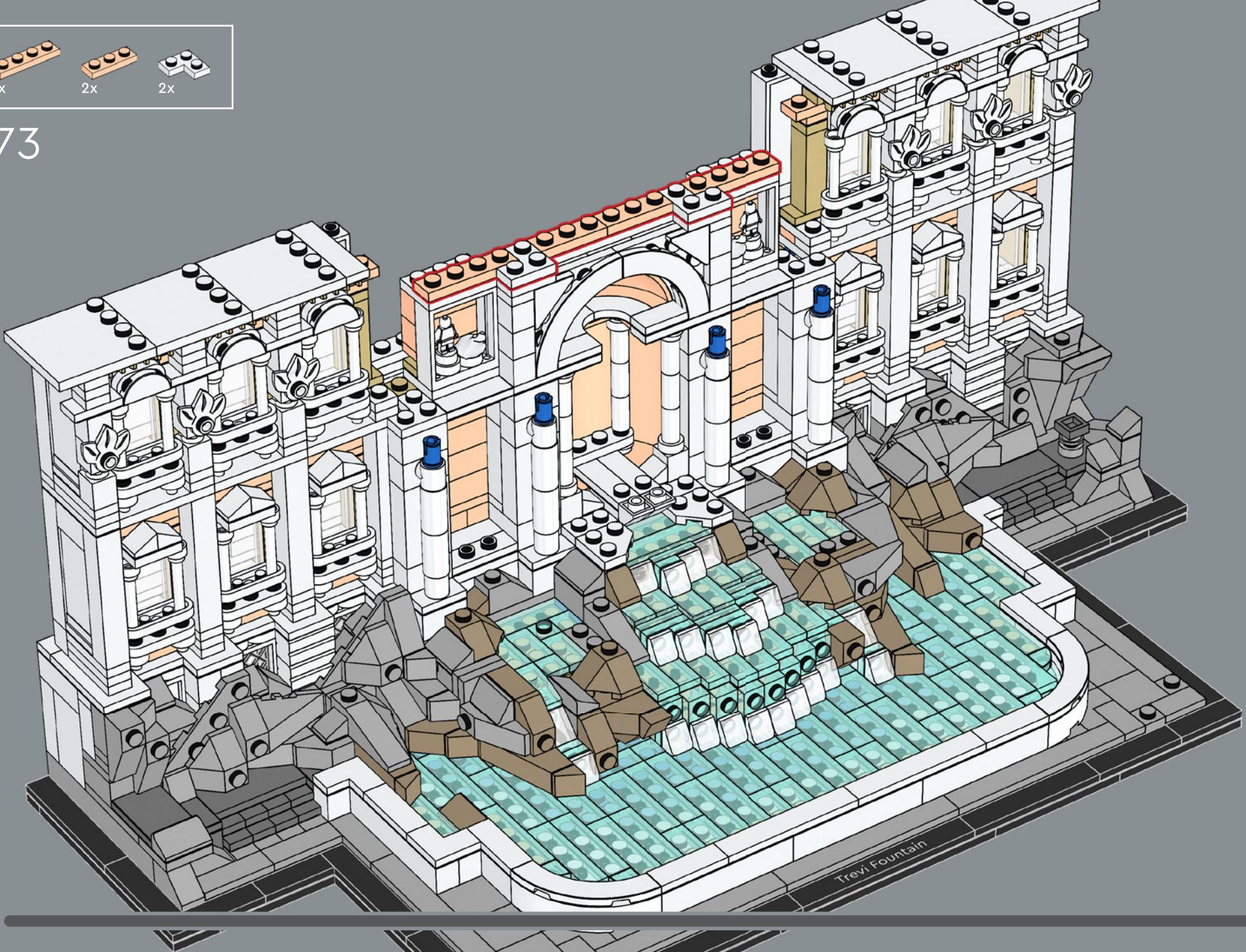

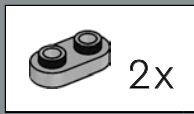
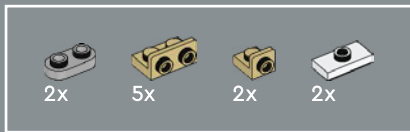

274

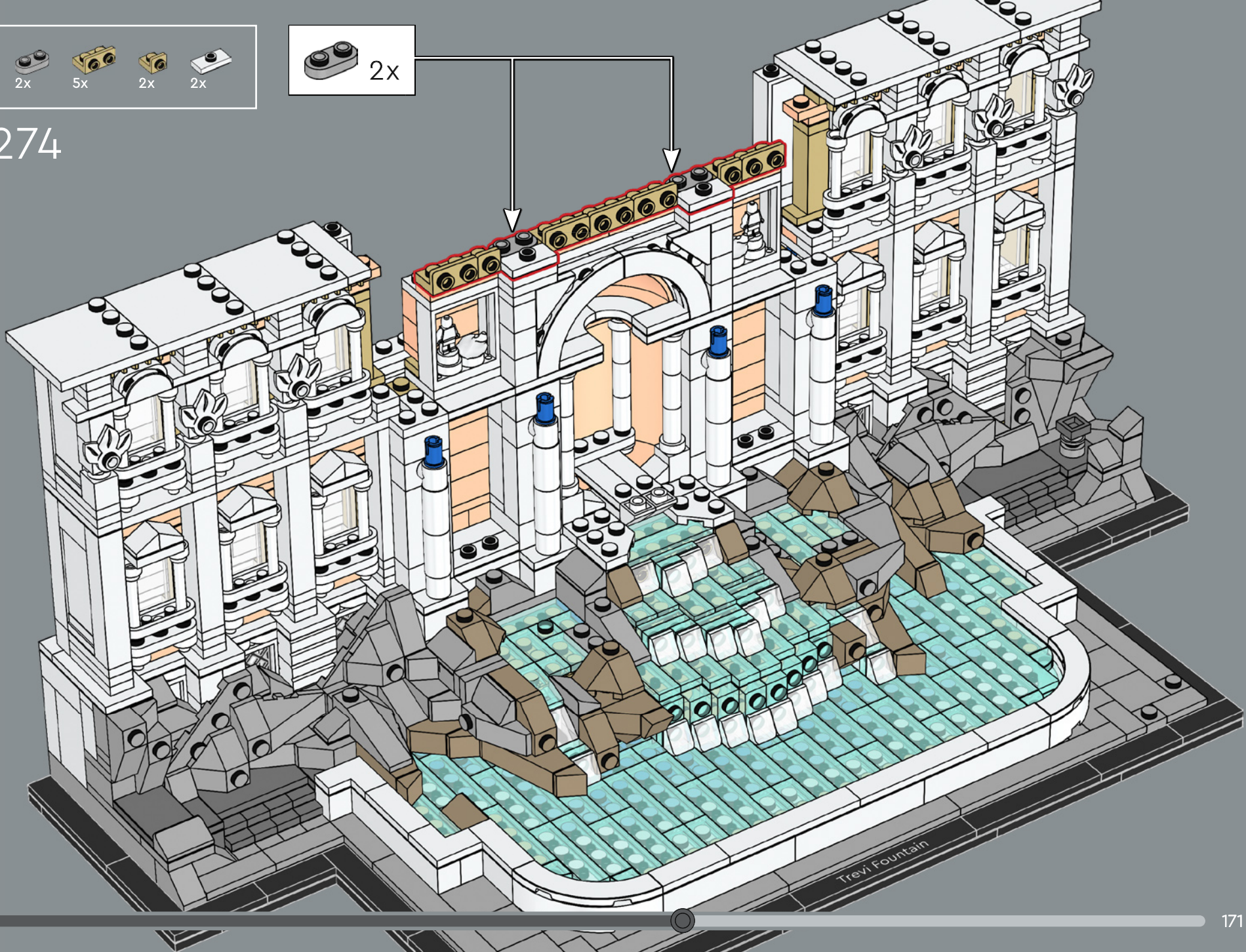

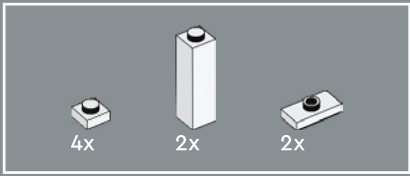

275

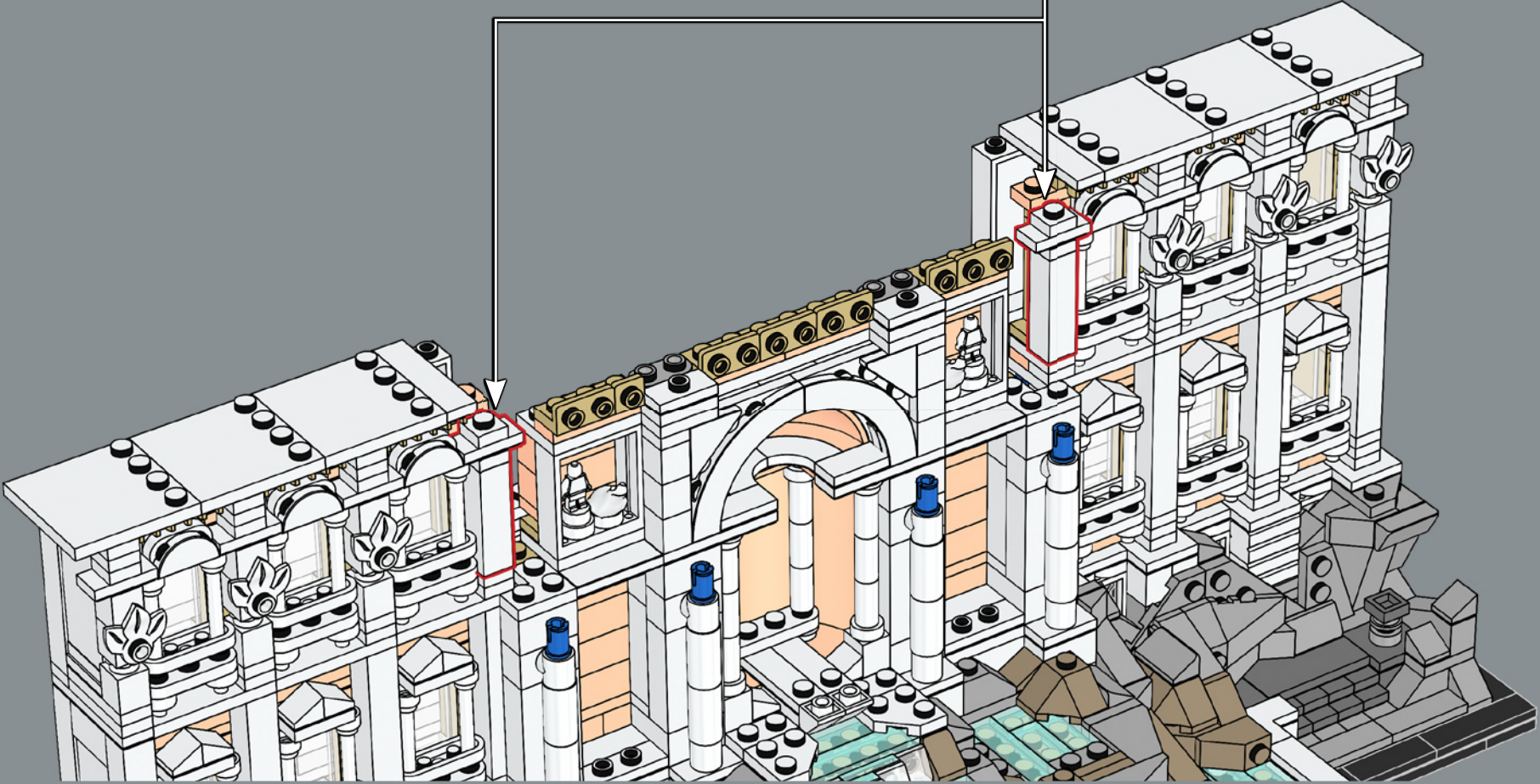
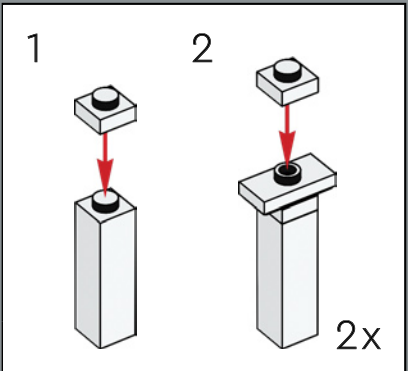



276

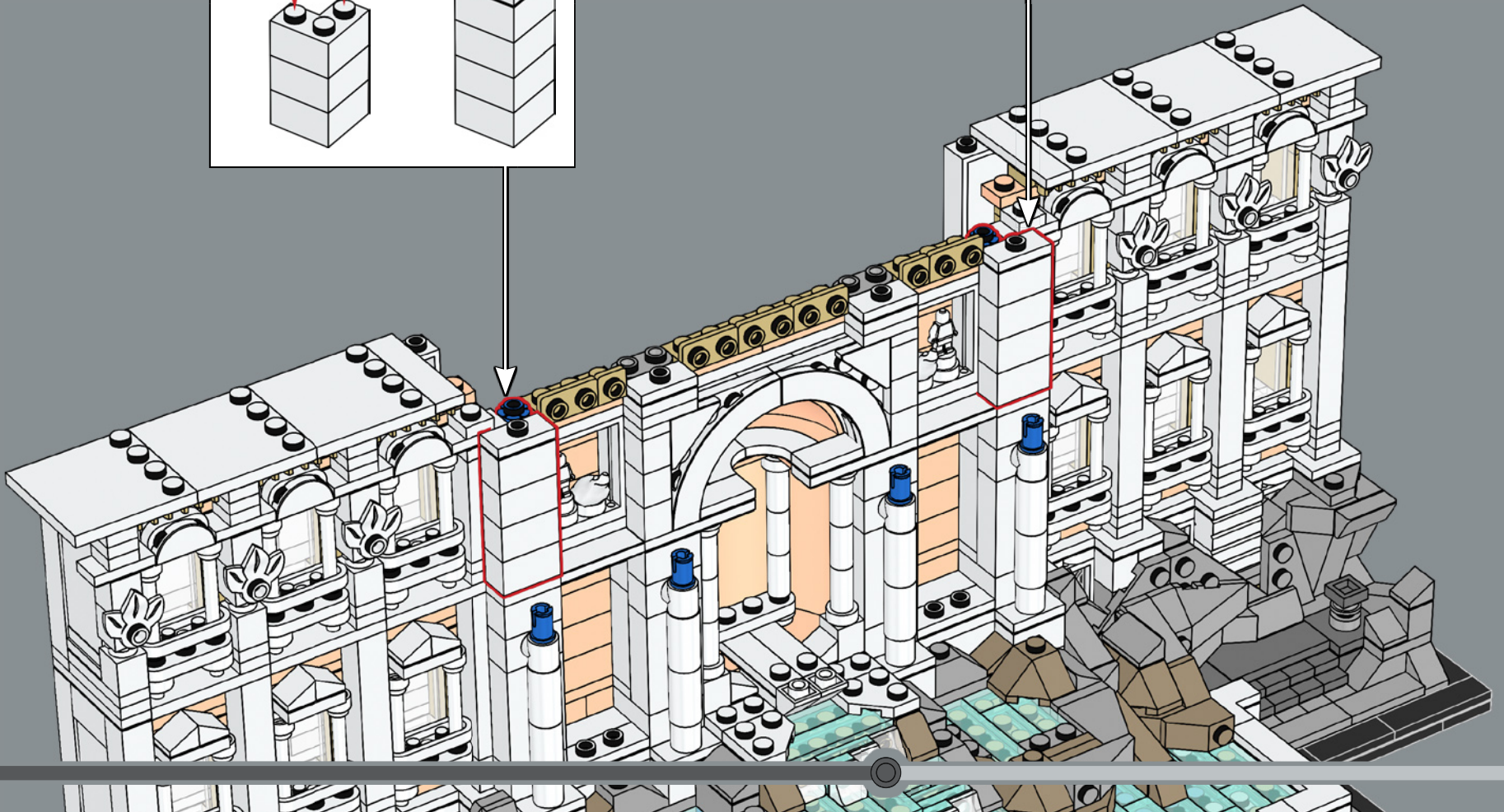
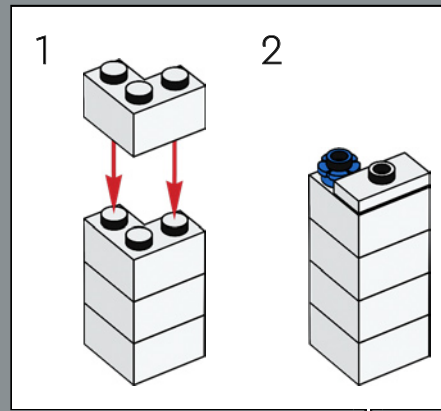
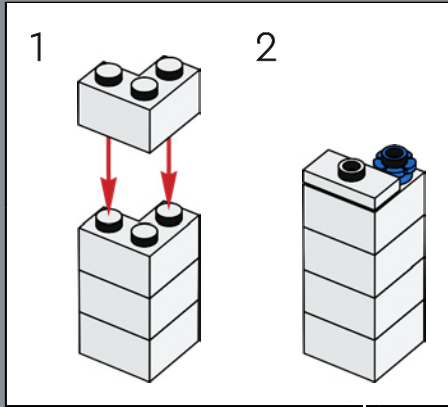



2x



277

1



3



2



4



5

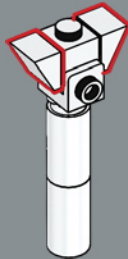

6

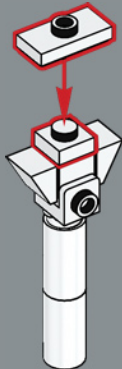

7

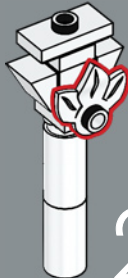

2x

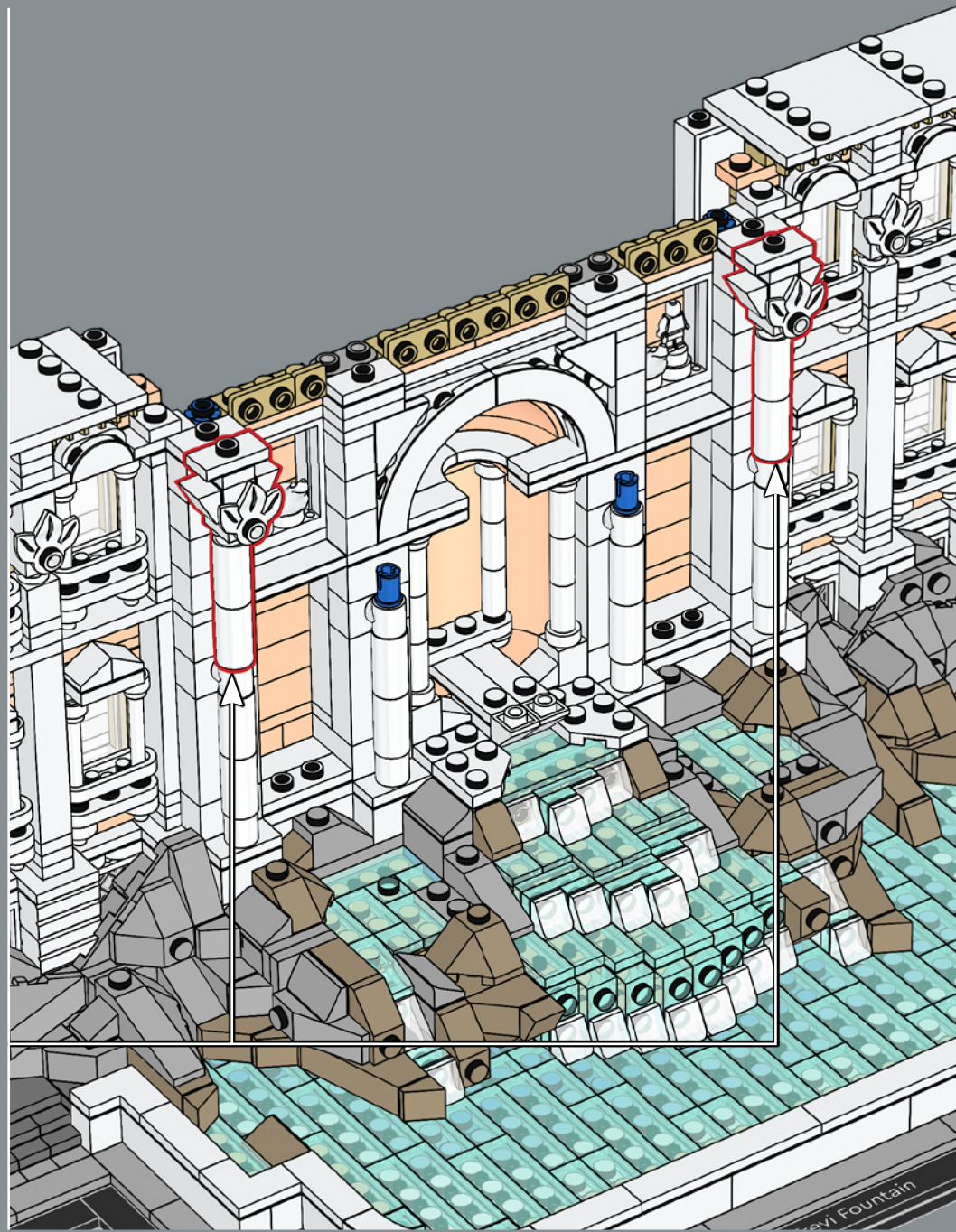

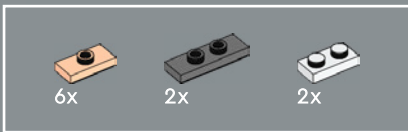

278

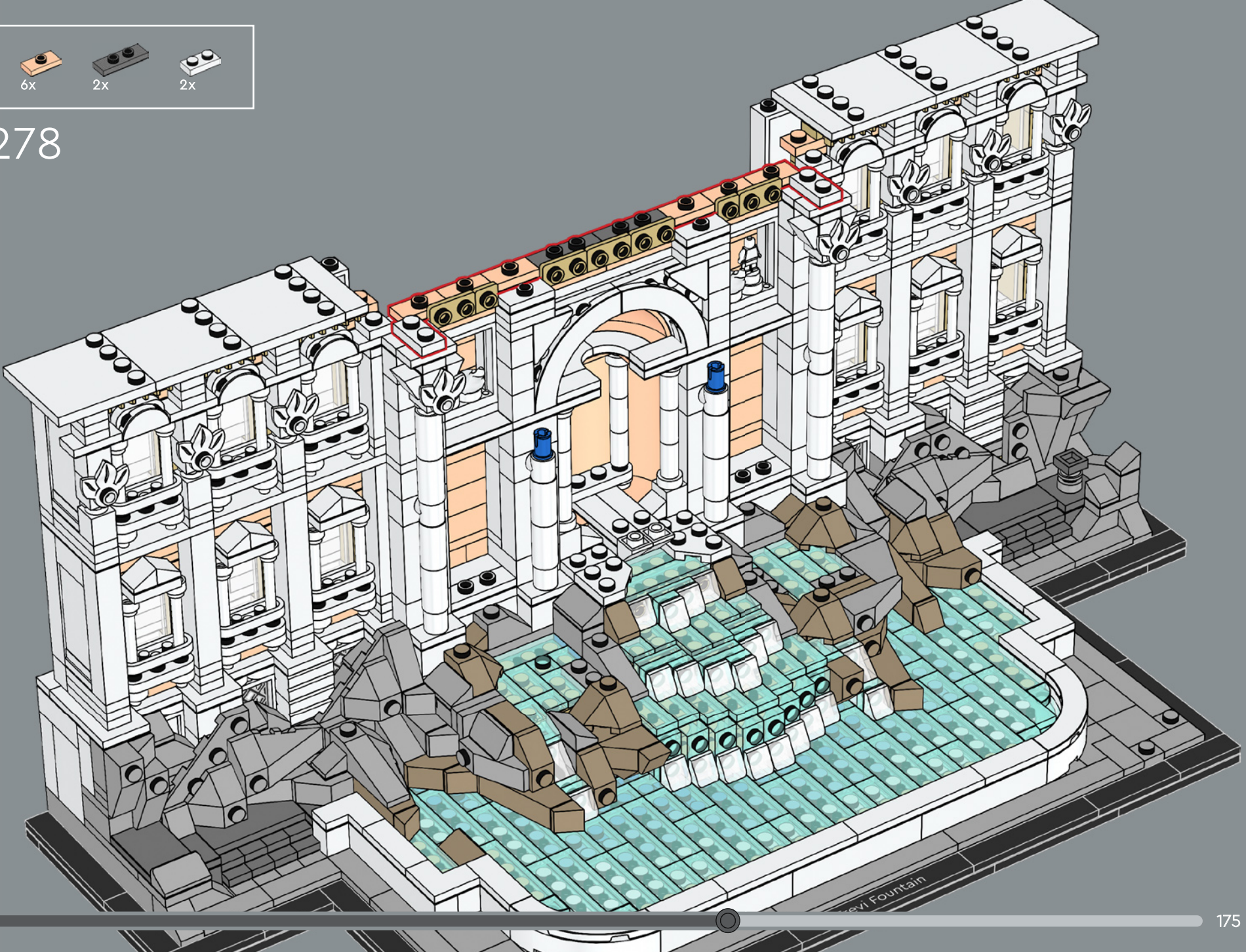

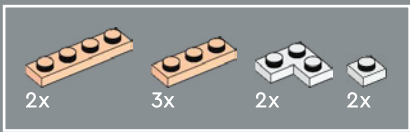

279

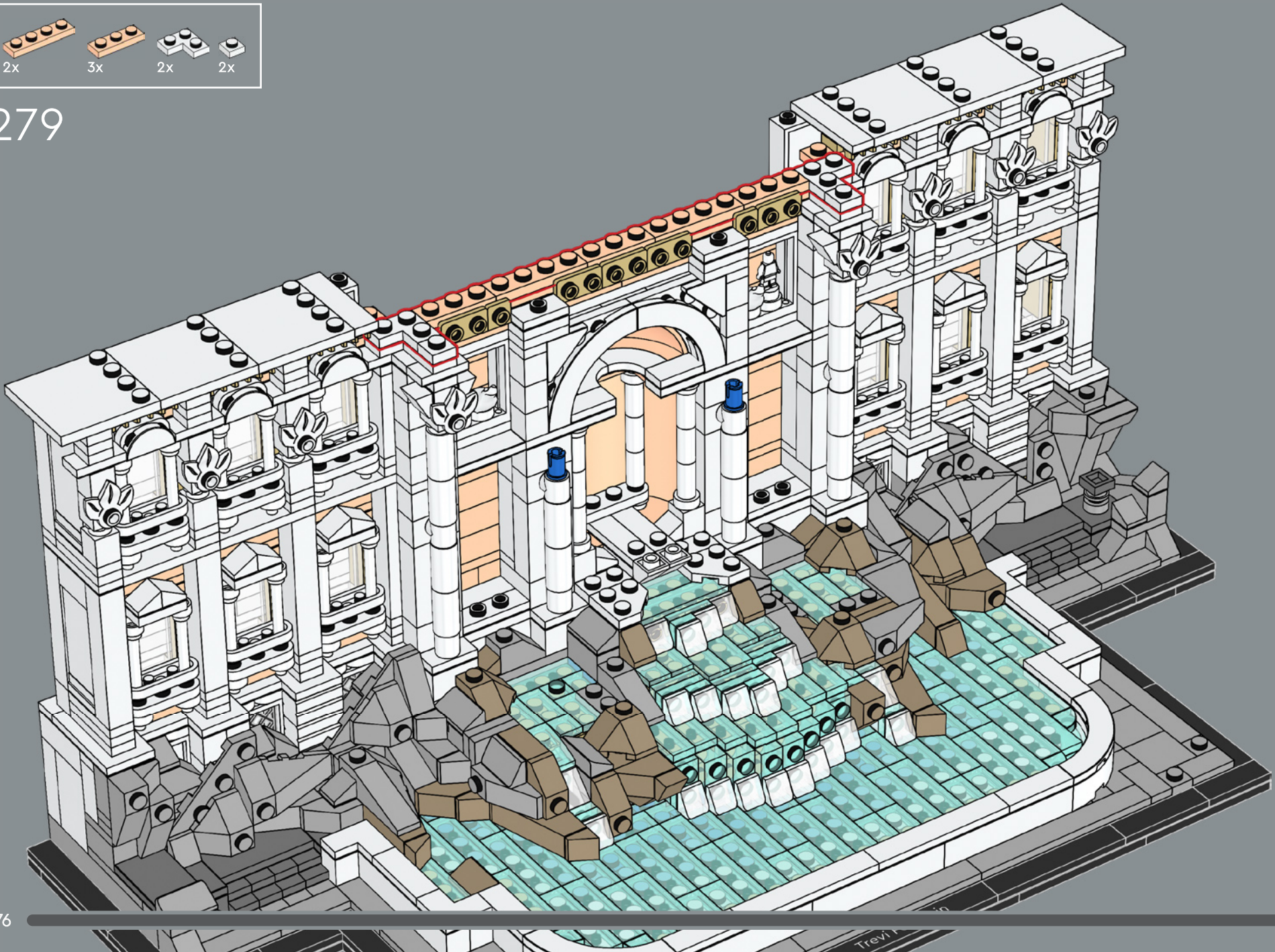

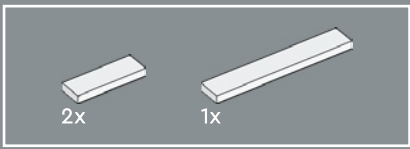

280

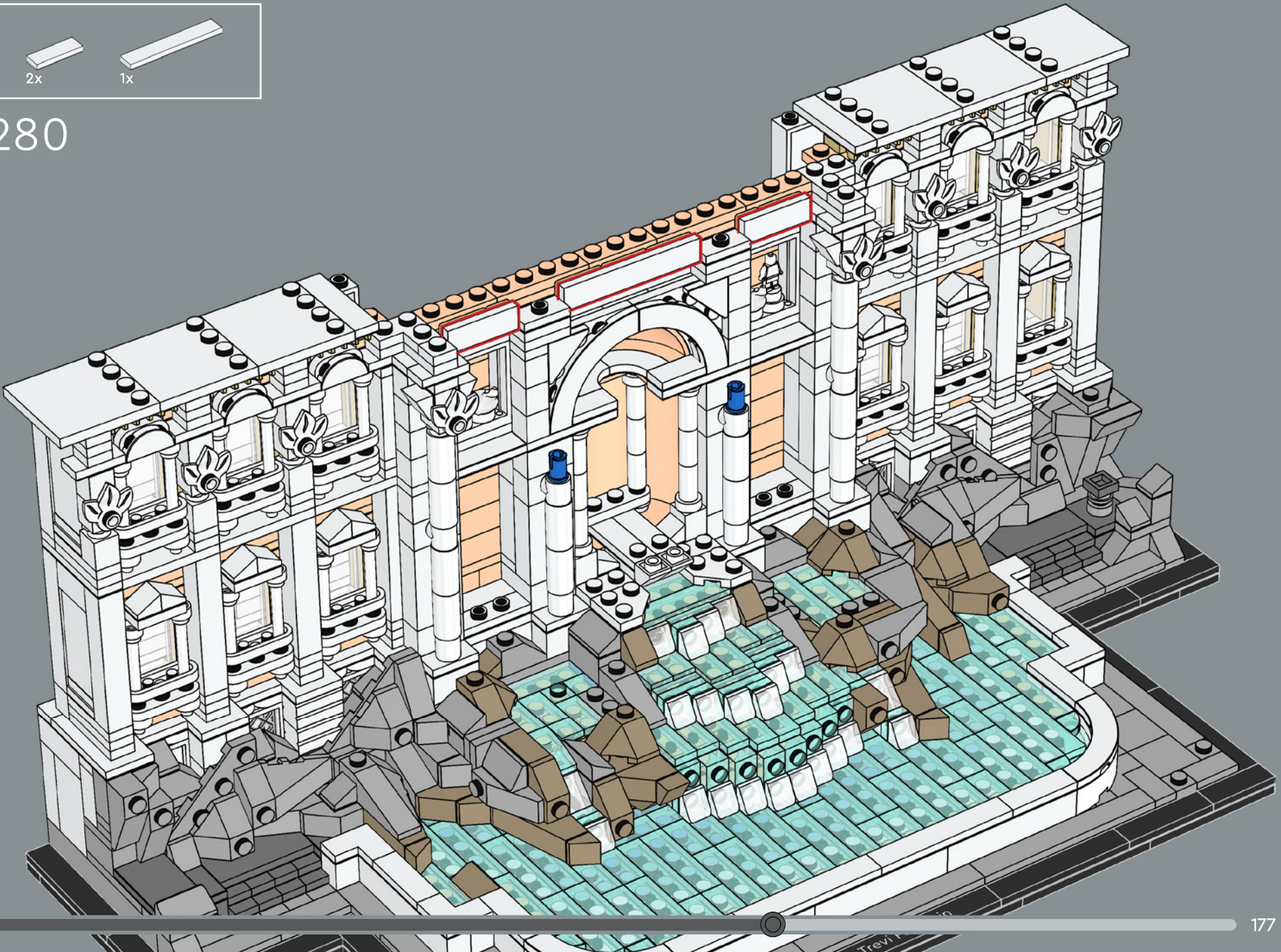



2x



281

1



2



3



4



5

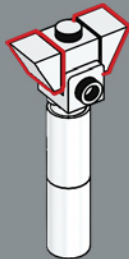

6

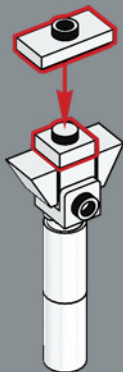

7

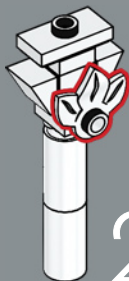

2x

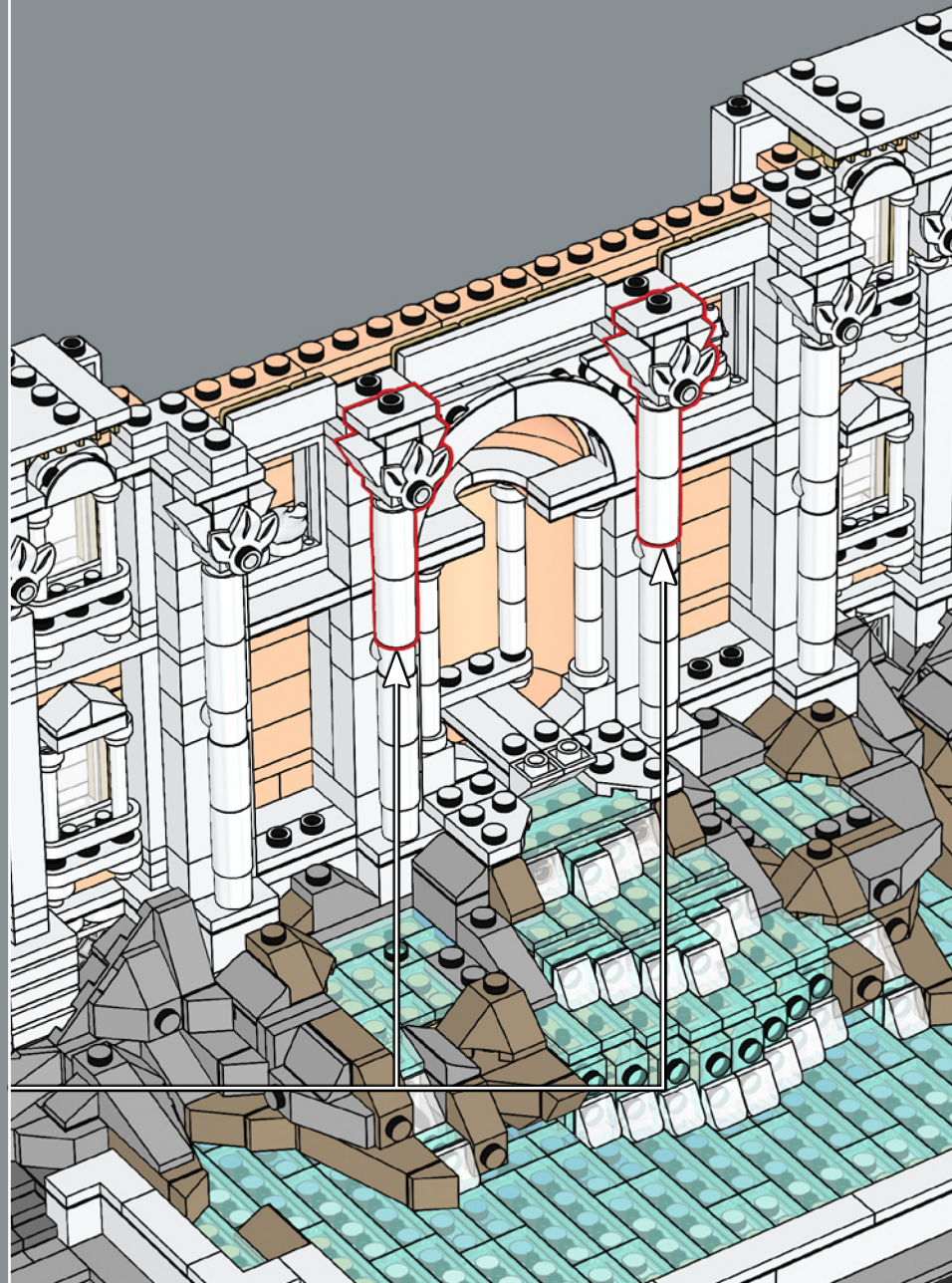

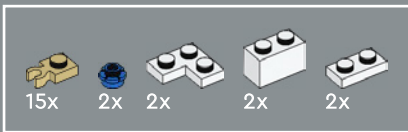

282

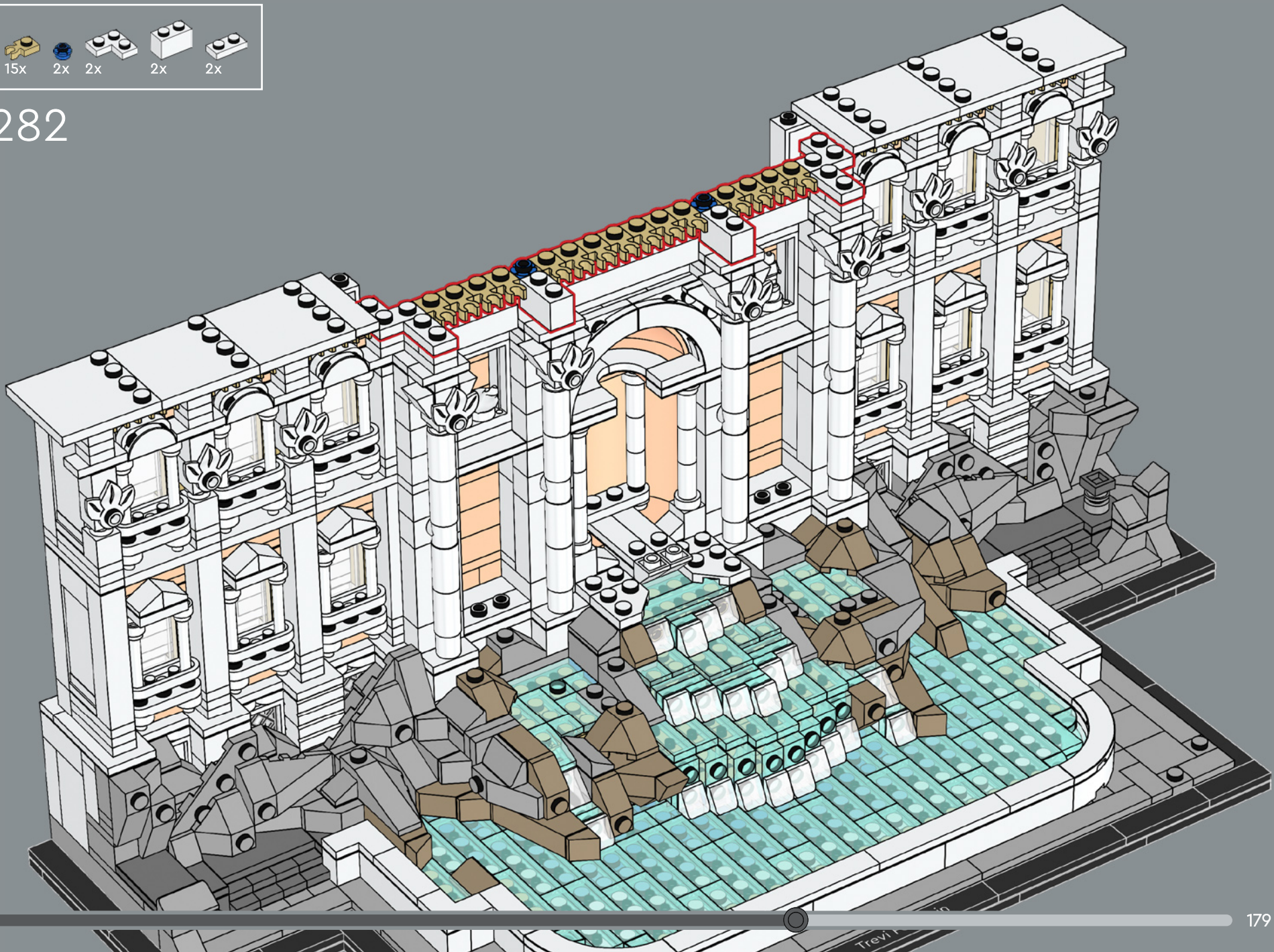

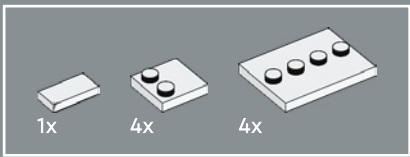

283

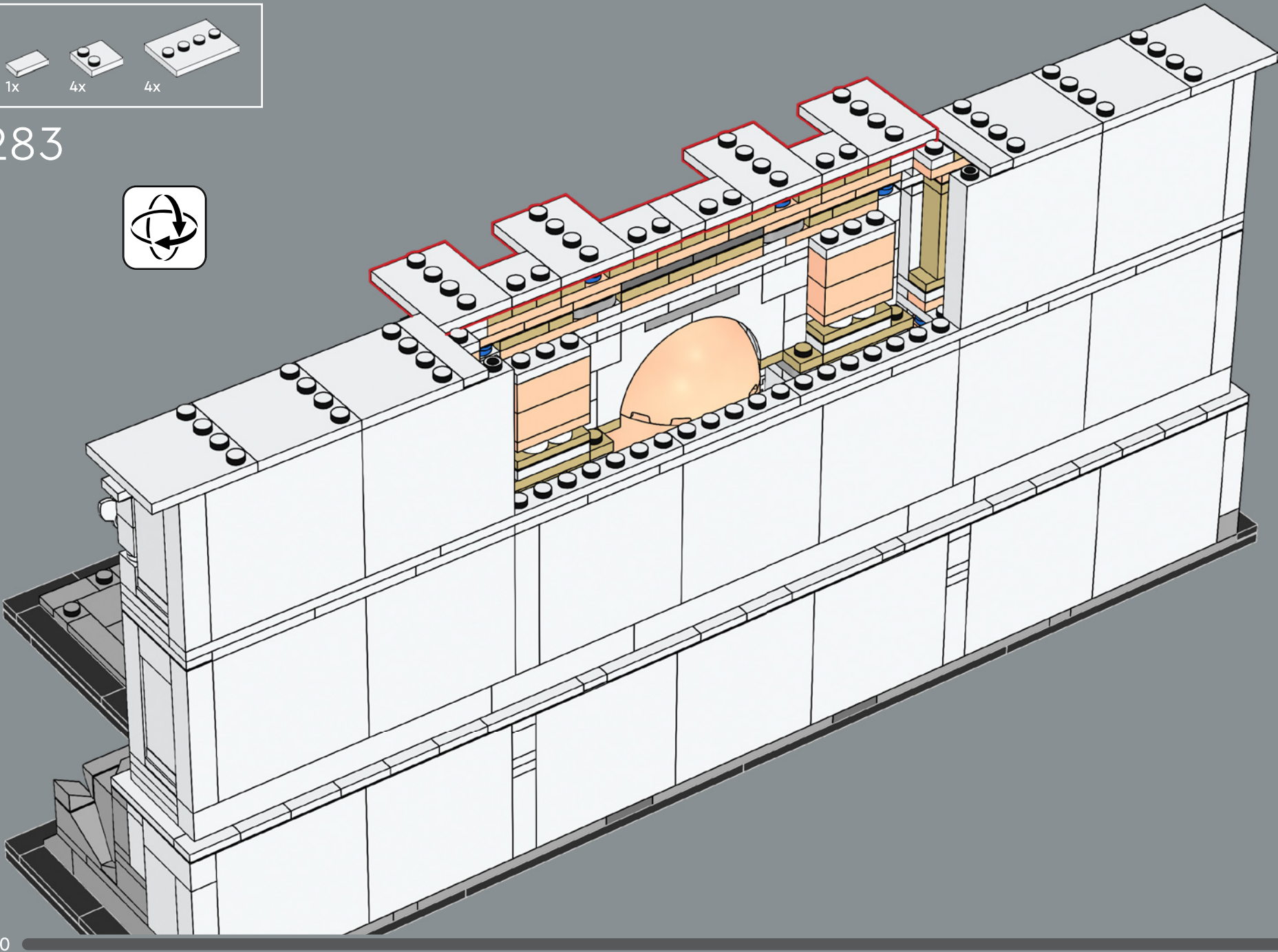

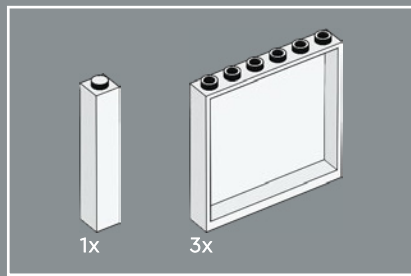

284

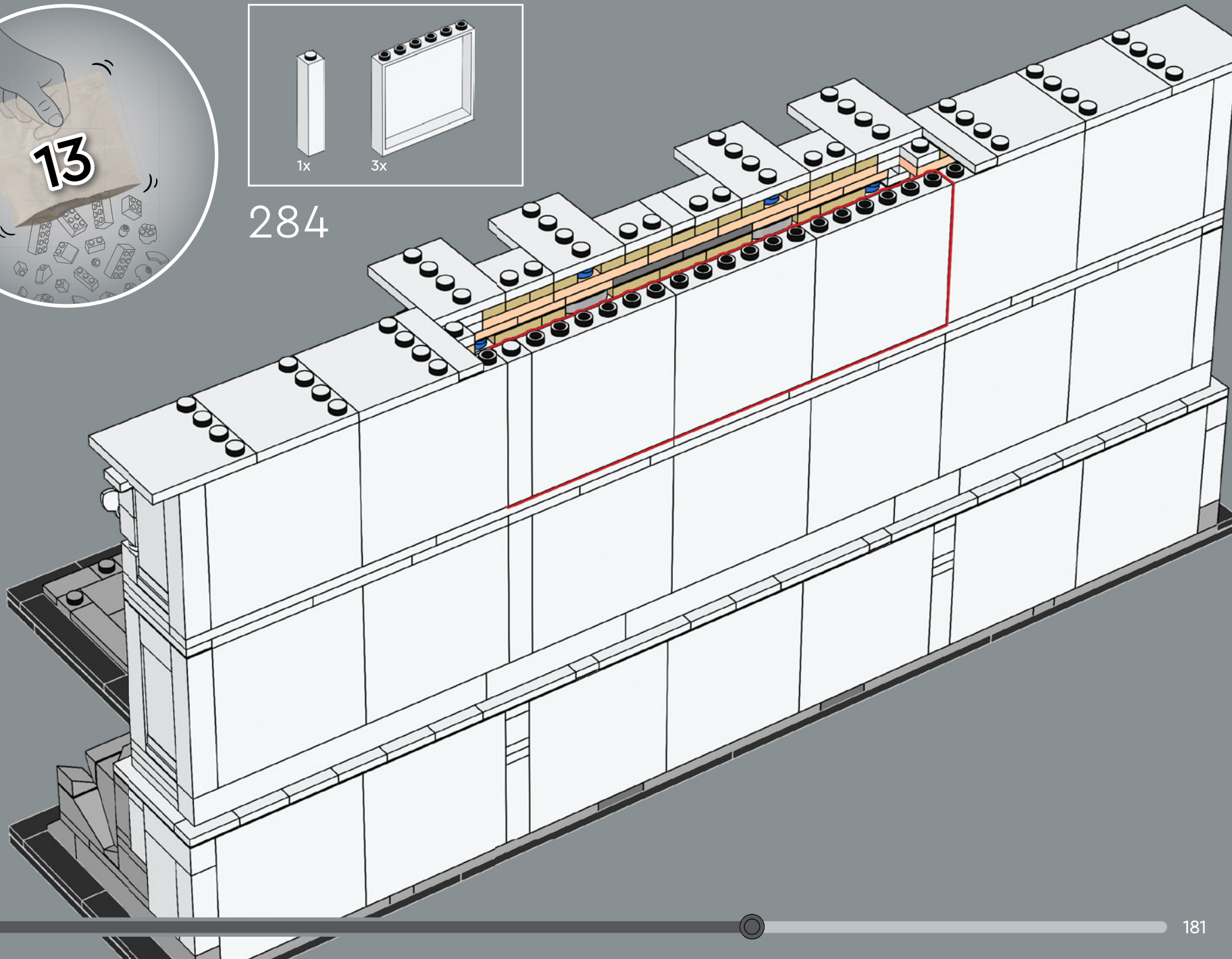

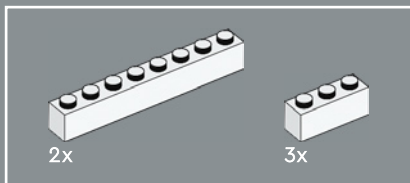

La véritable fontaine de Trevi est en réalité la façade du palais Poli, une ancienne résidence papale qui abrite aujourd'hui un musée. Vers l'arrière, le bâtiment se poursuit avec une architecture en harmonie avec les constructions environnantes plutôt qu'avec le style baroque de la fontaine.

285

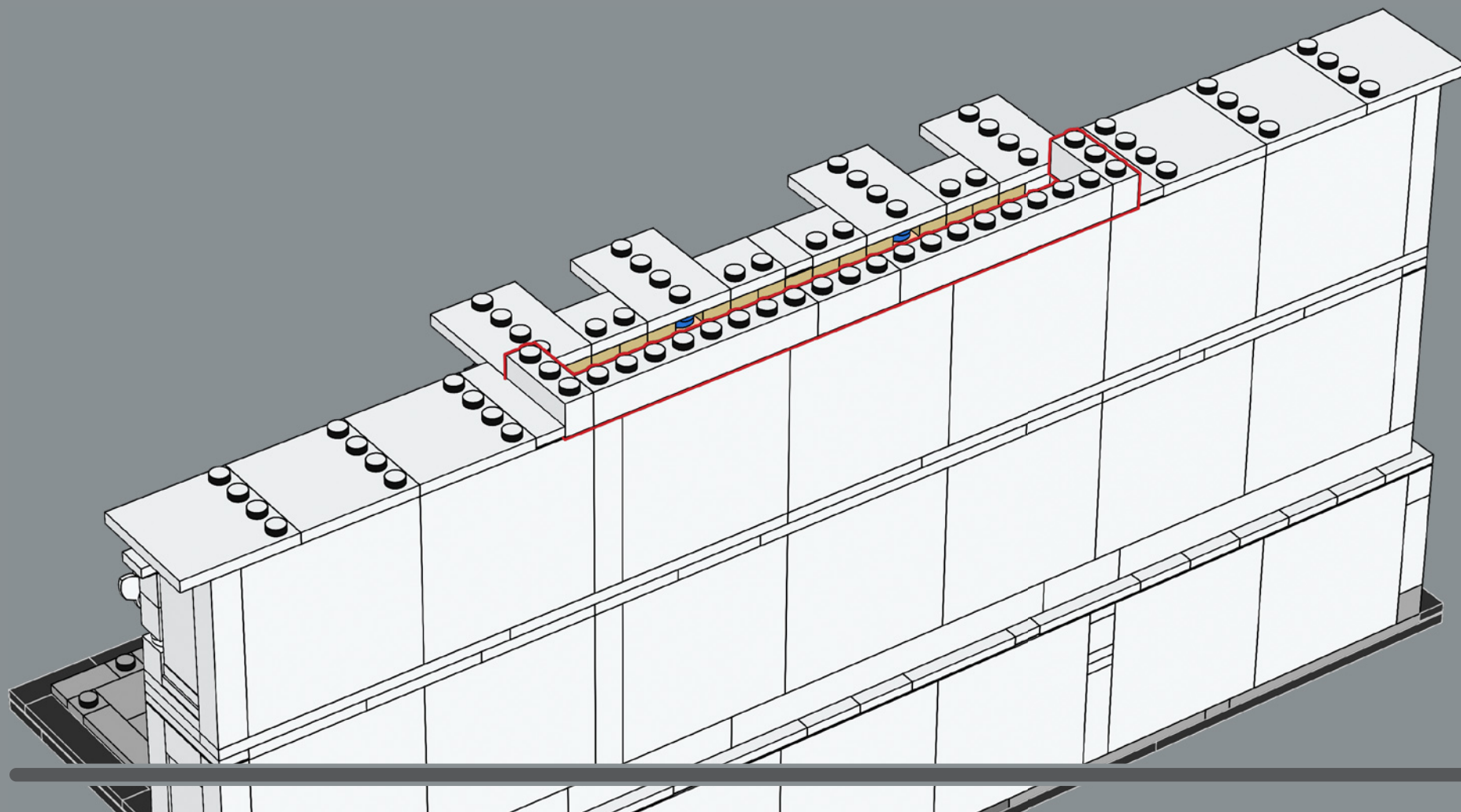

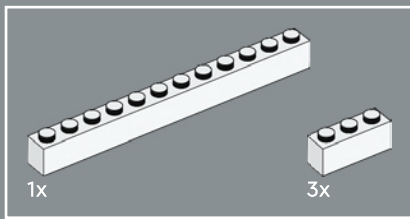

286

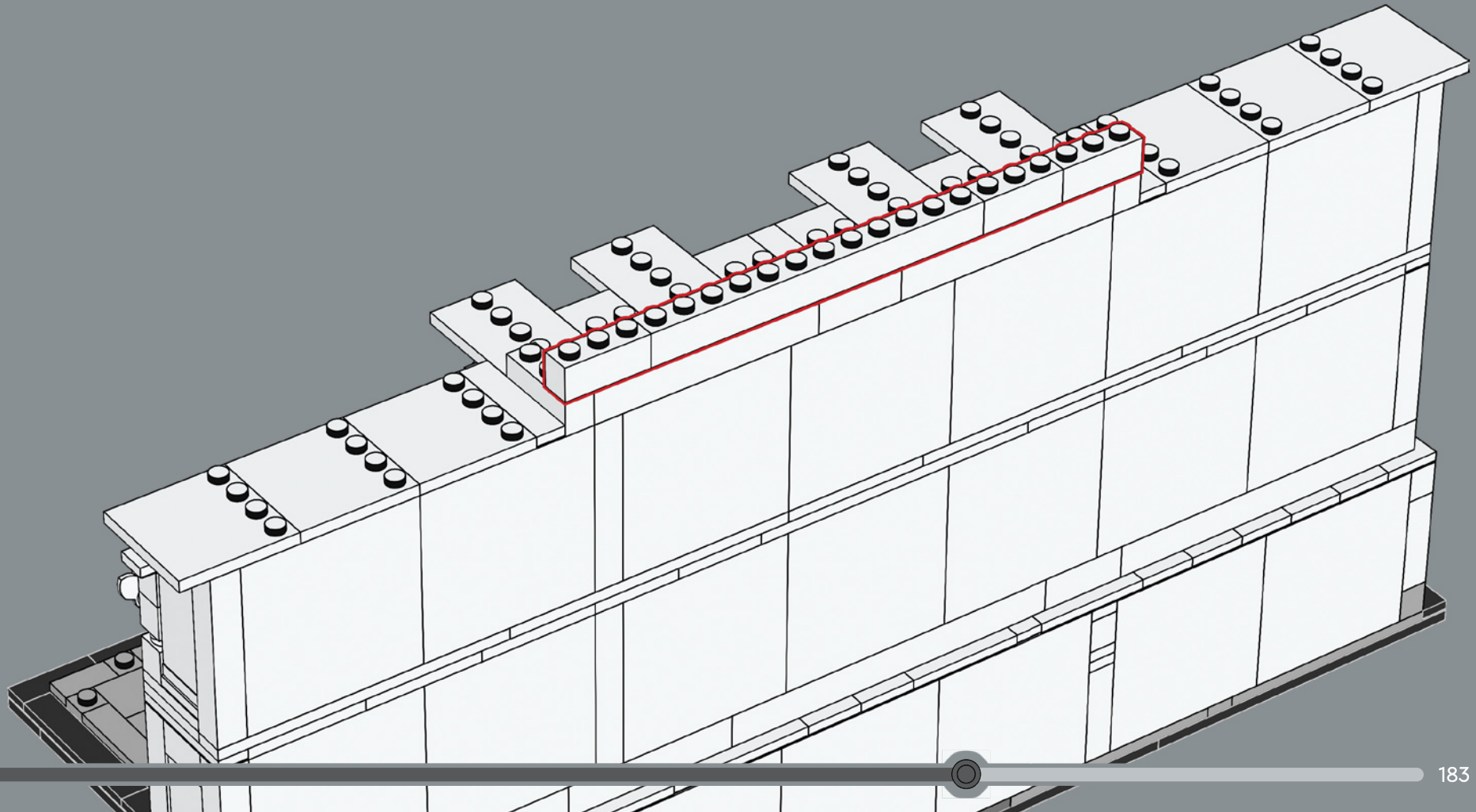

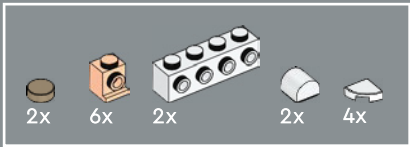

287

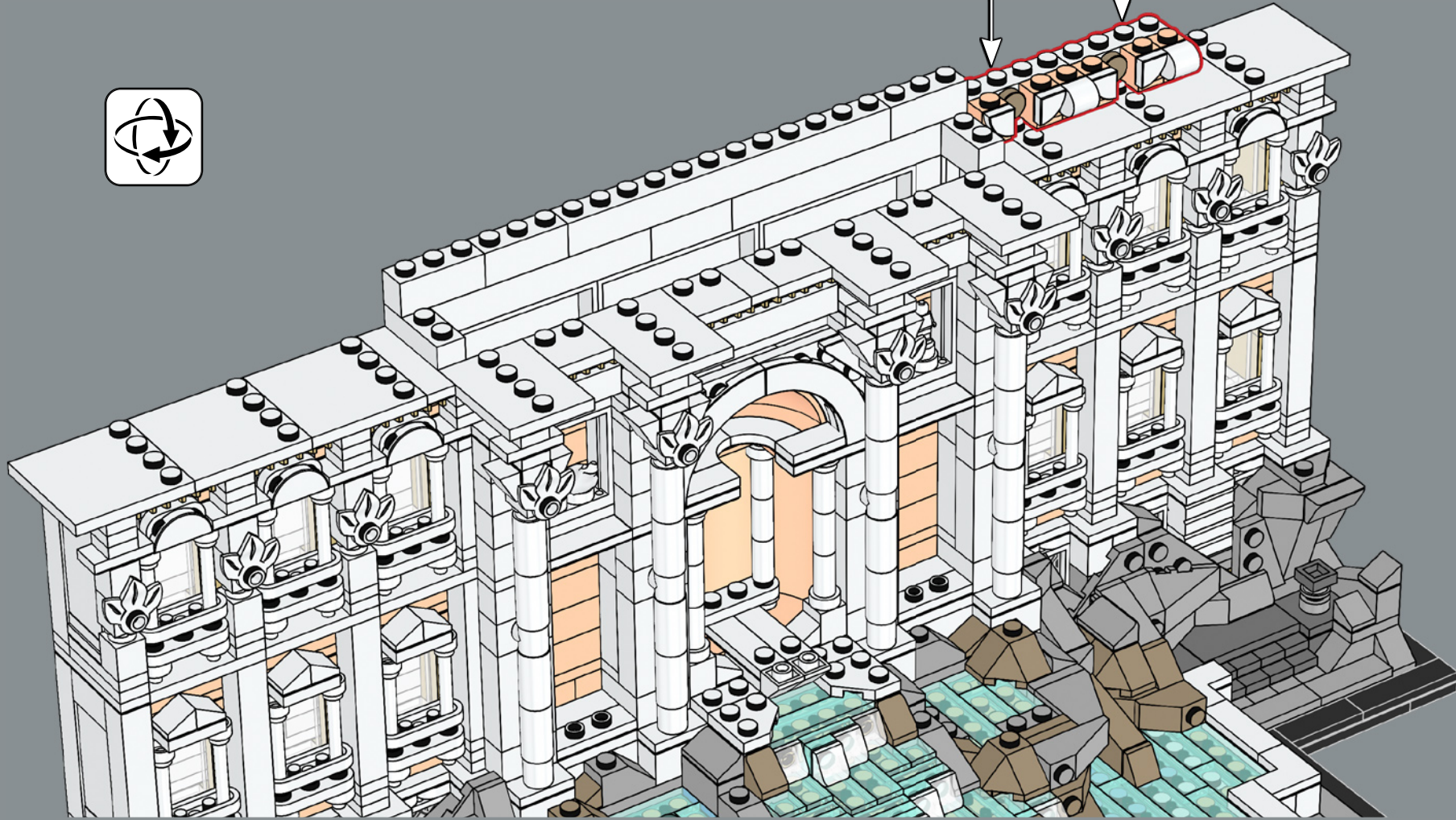
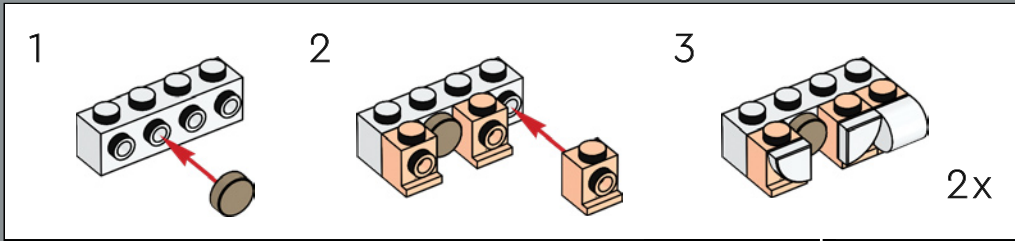

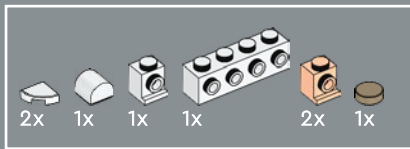

288

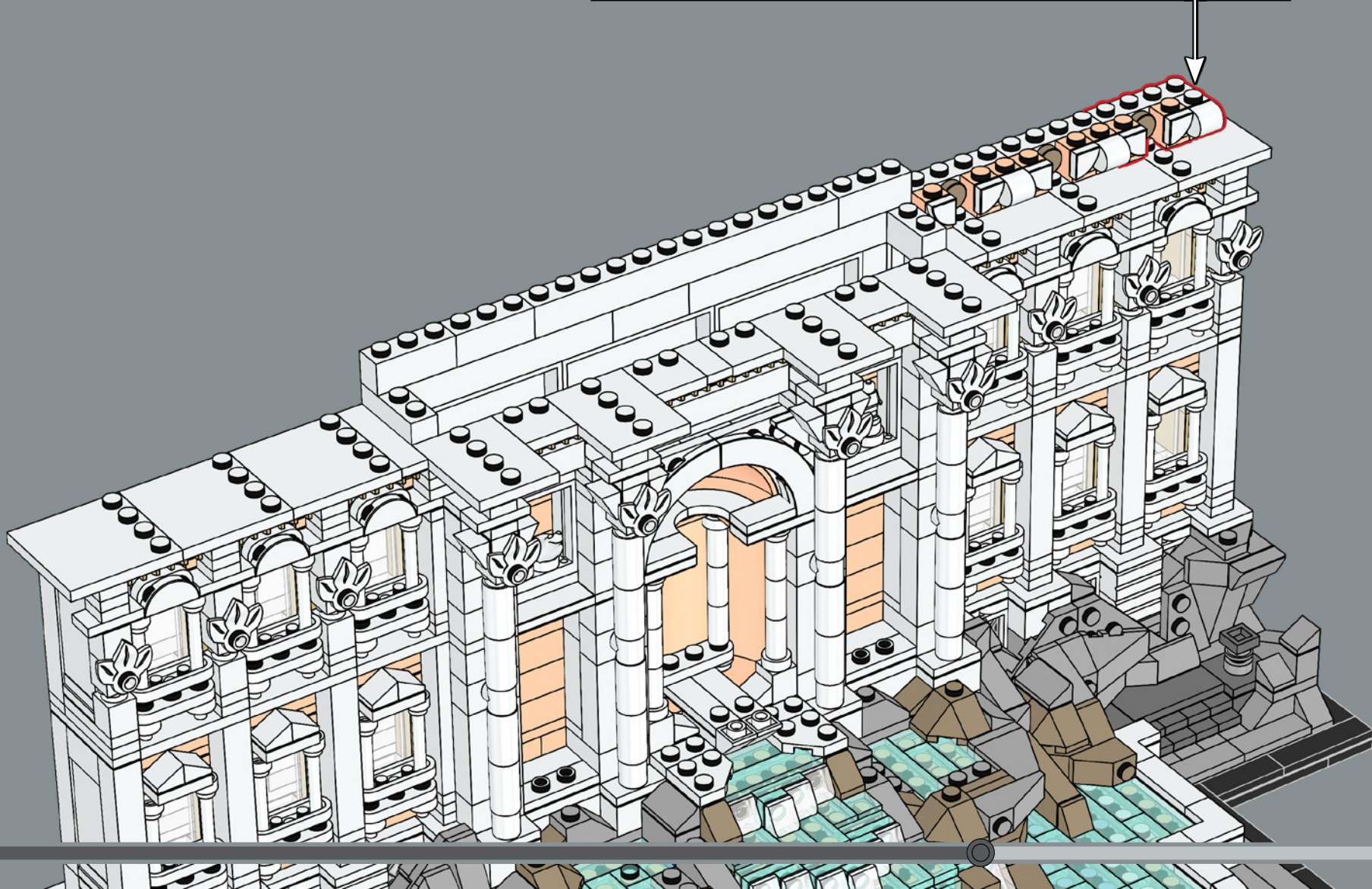
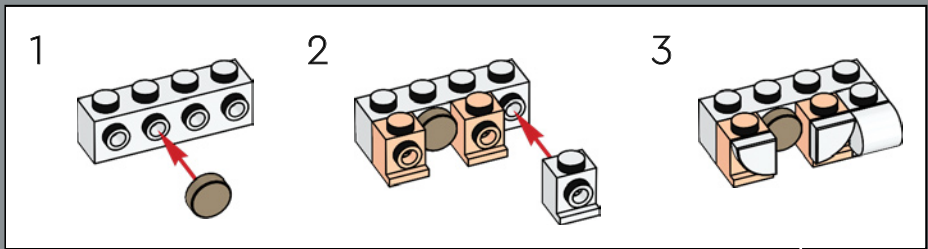

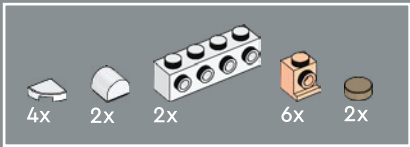

289

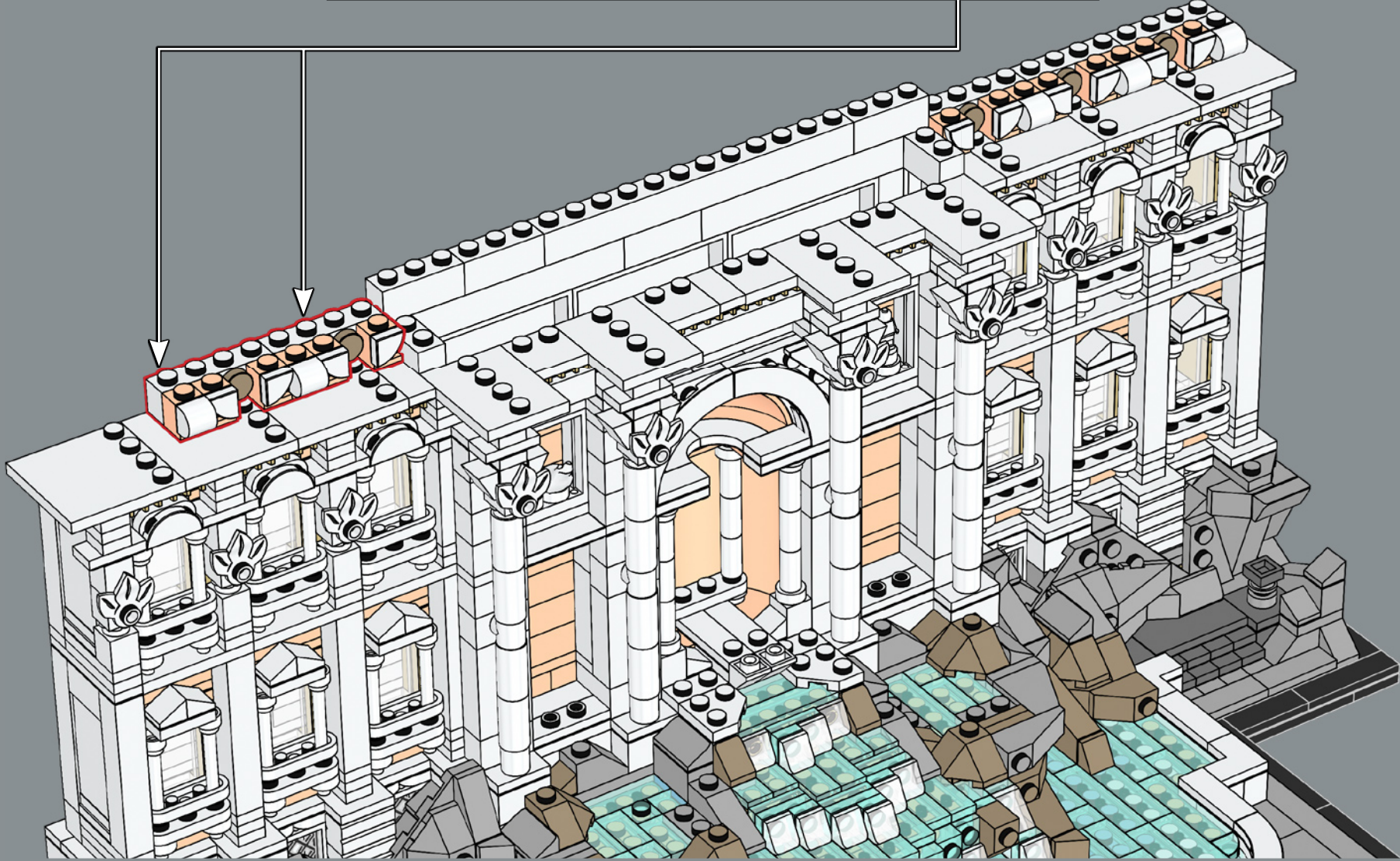
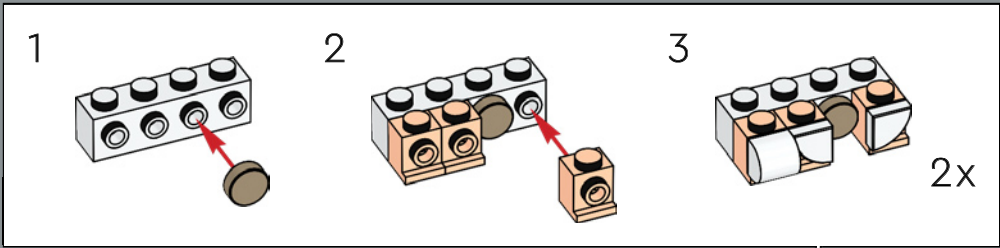

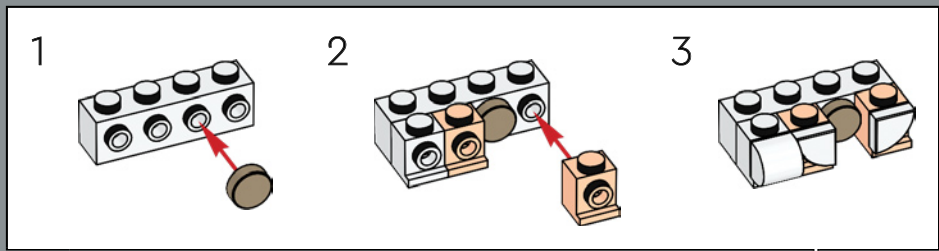
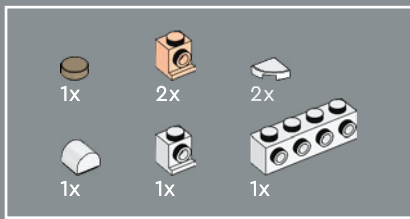

290

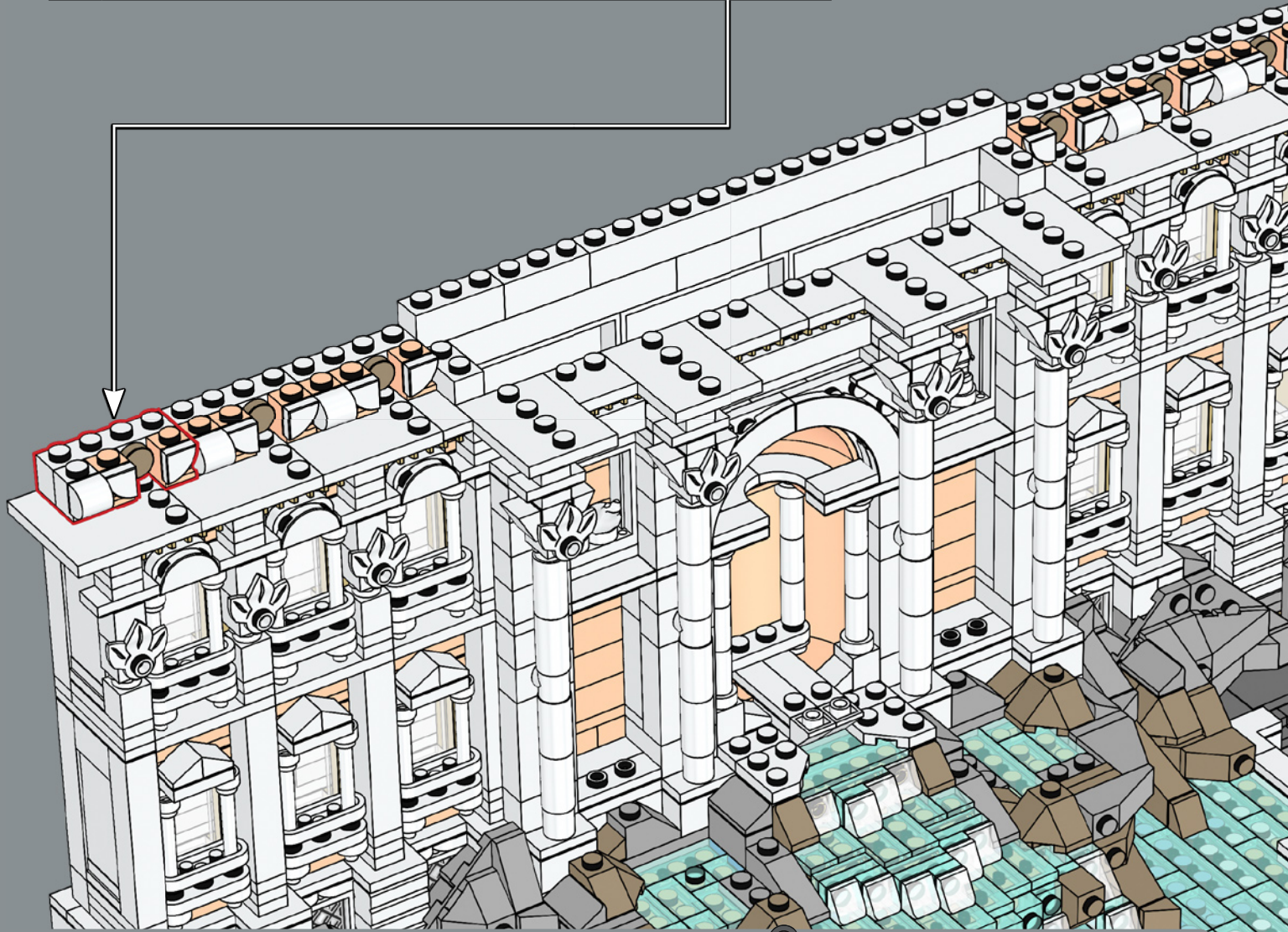



6x

291

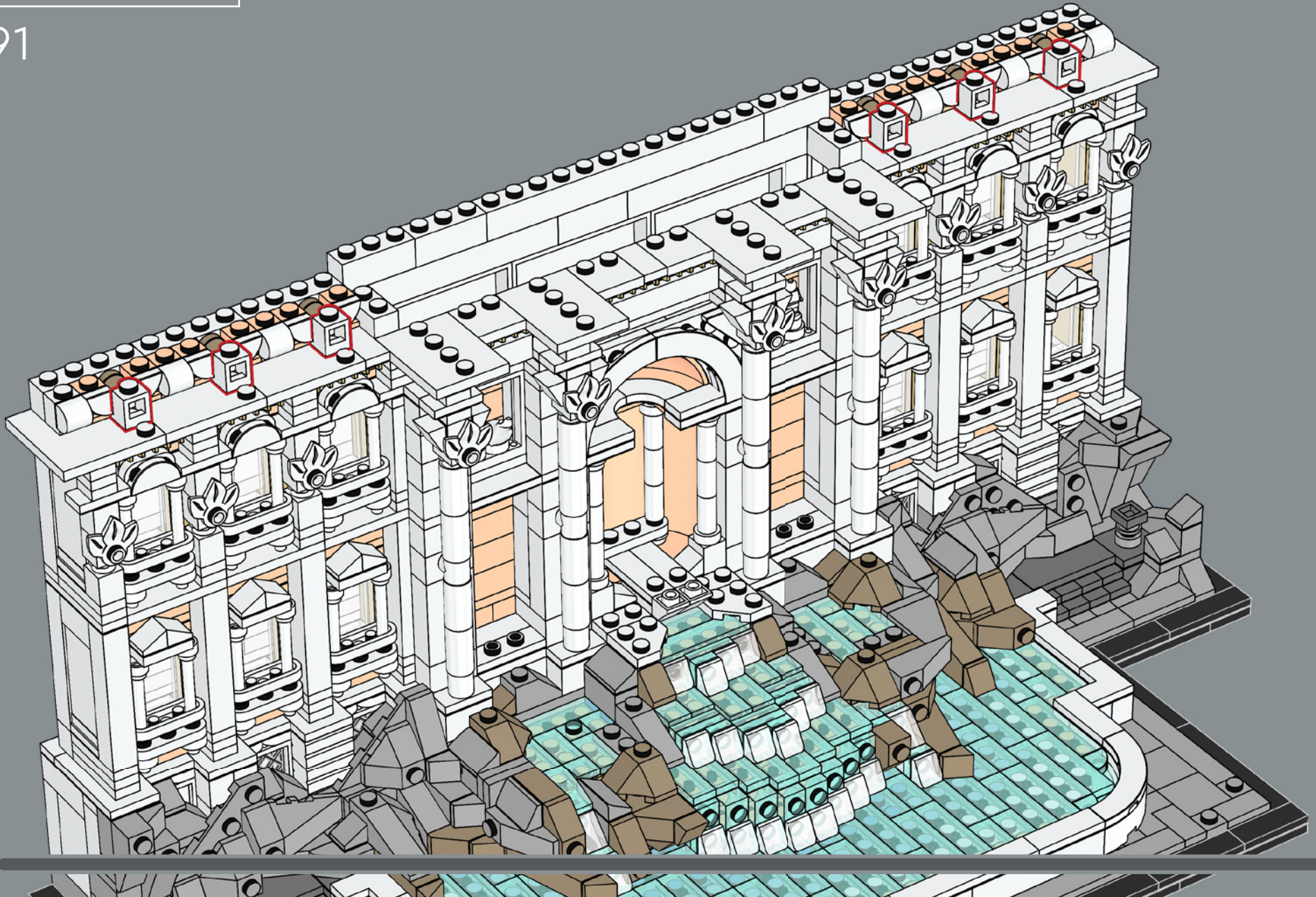

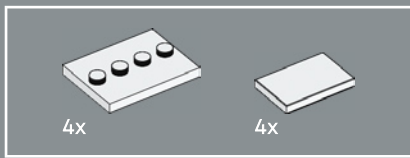

292

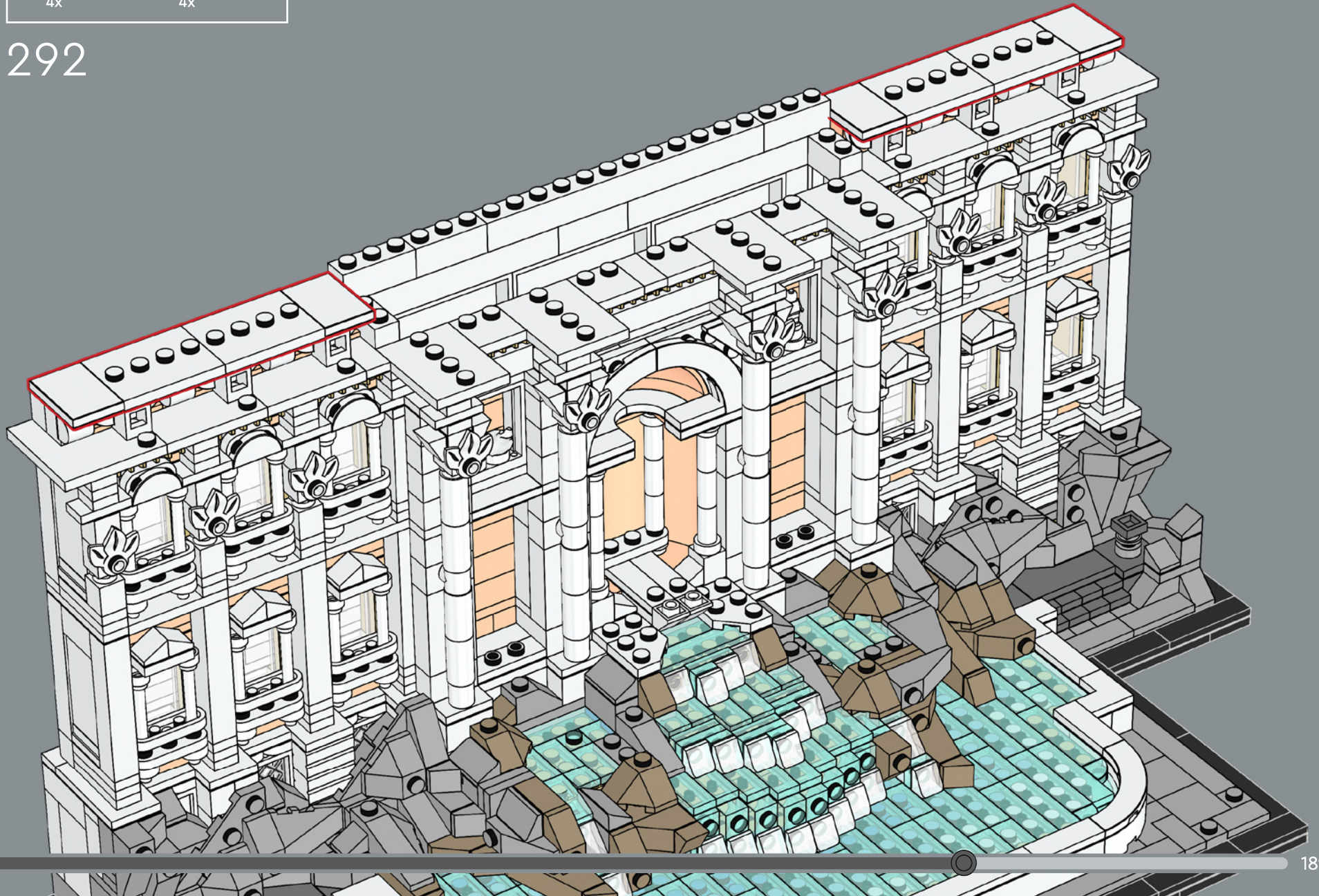

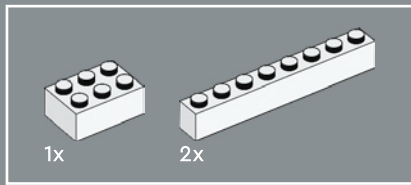

293

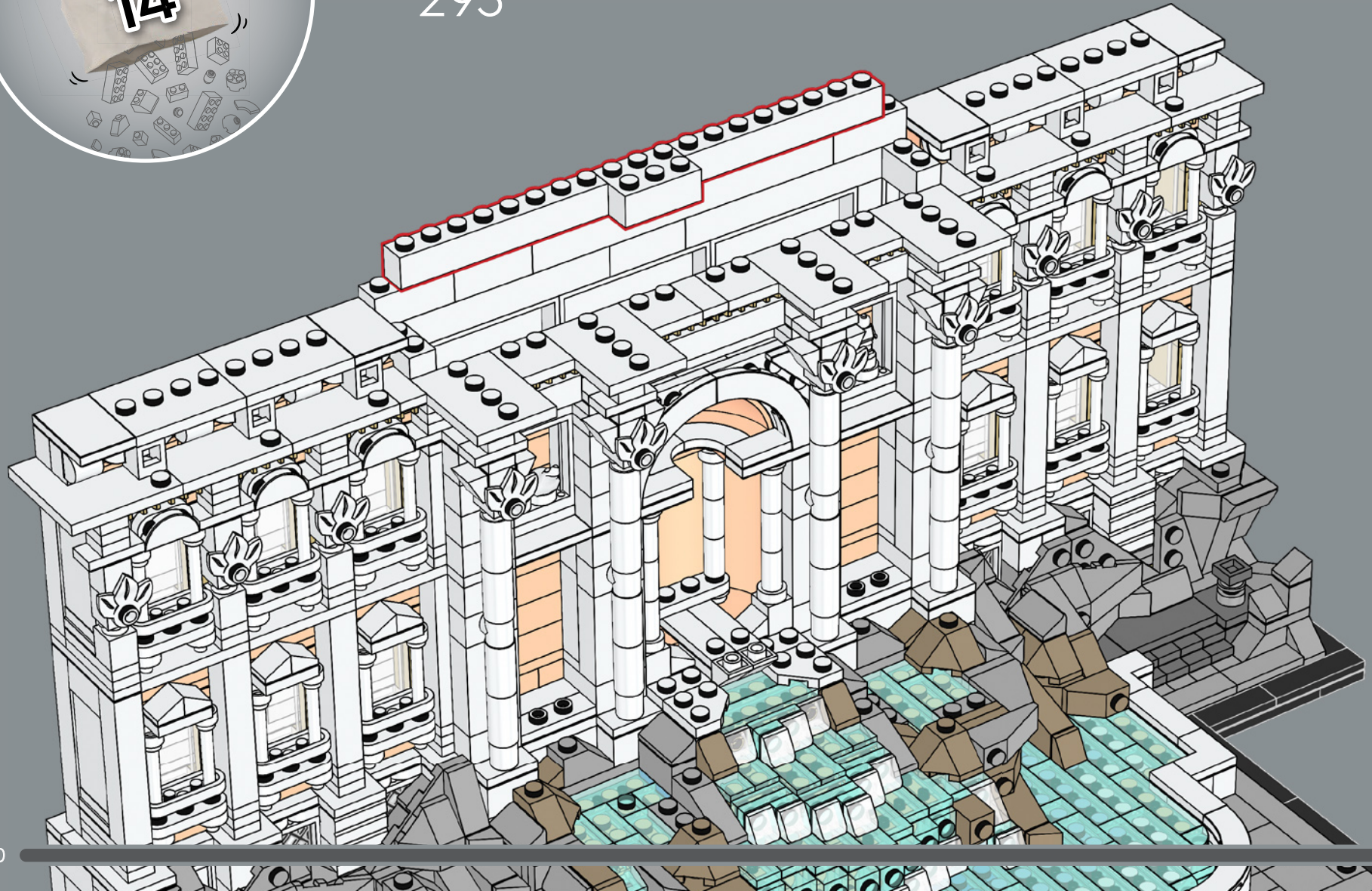

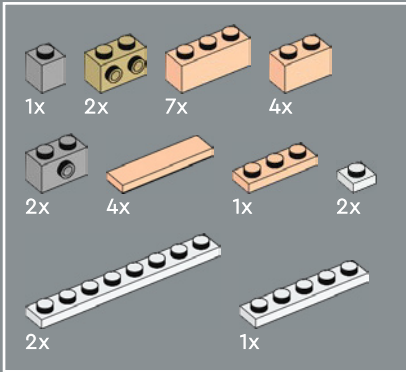
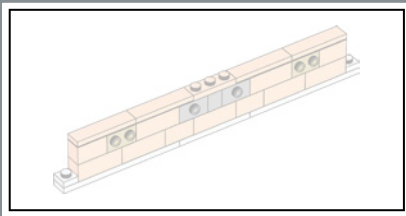

294

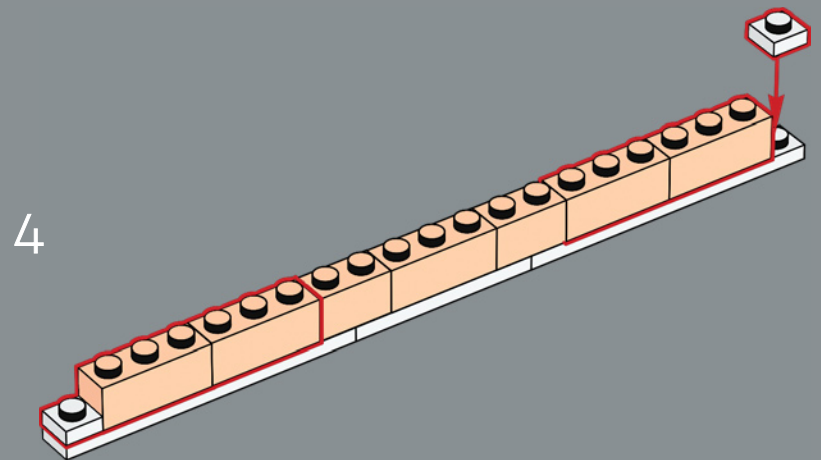
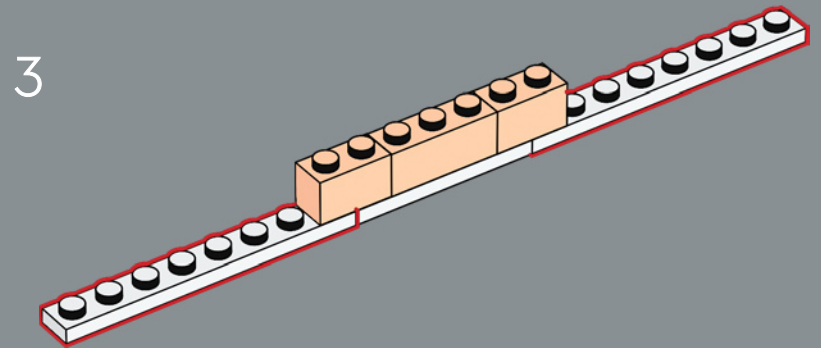
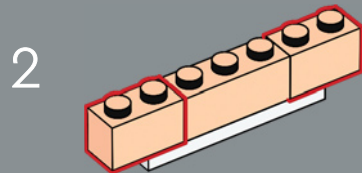
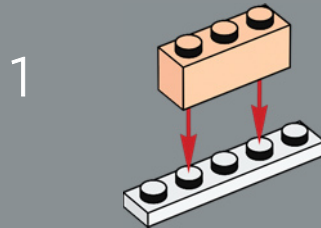

5

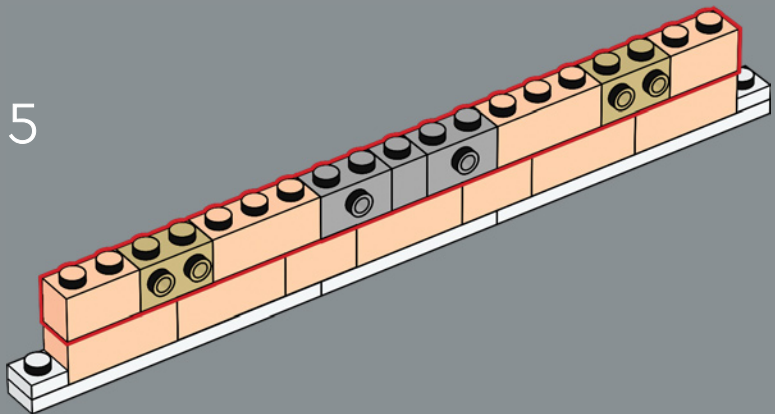

6

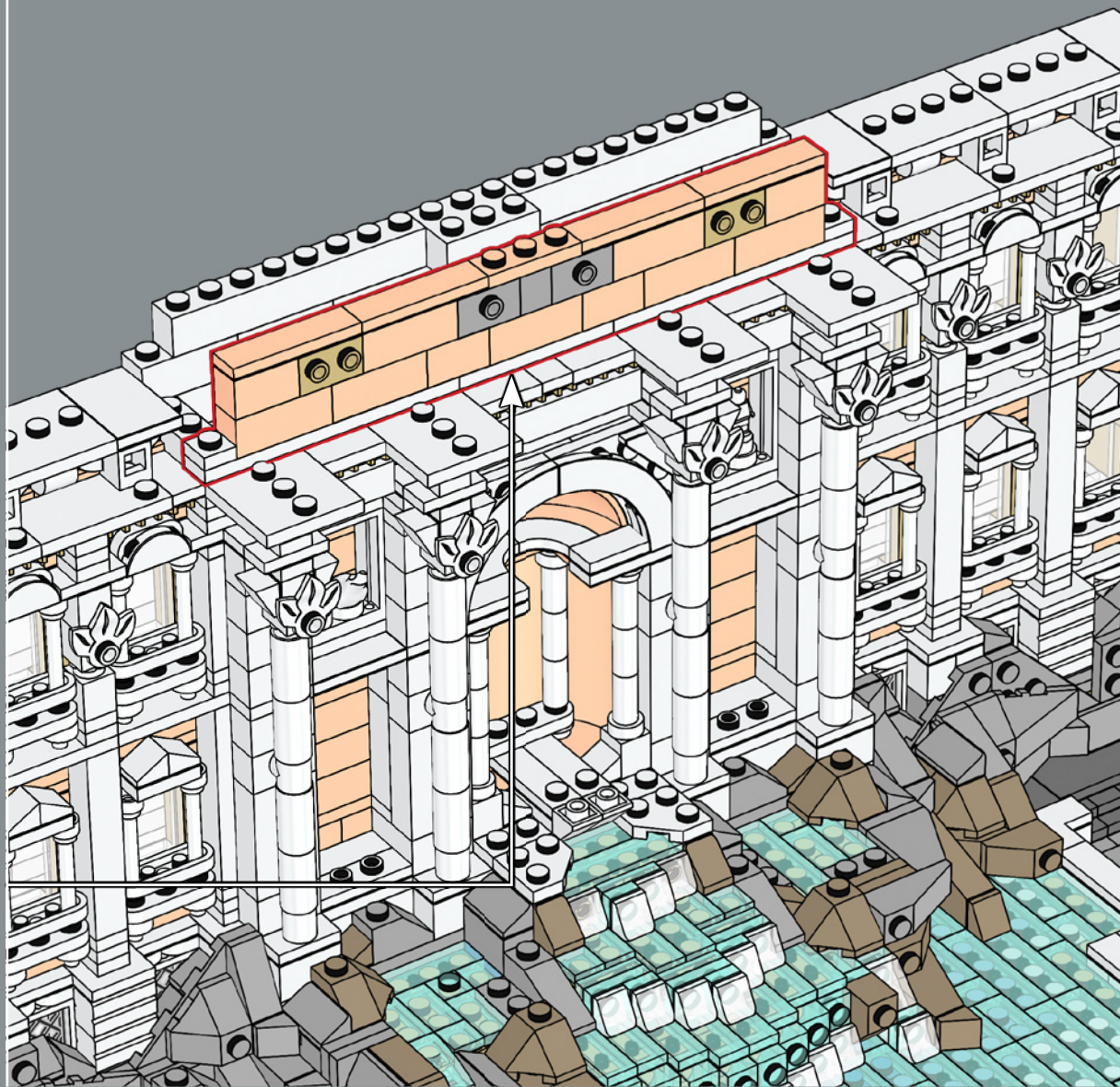
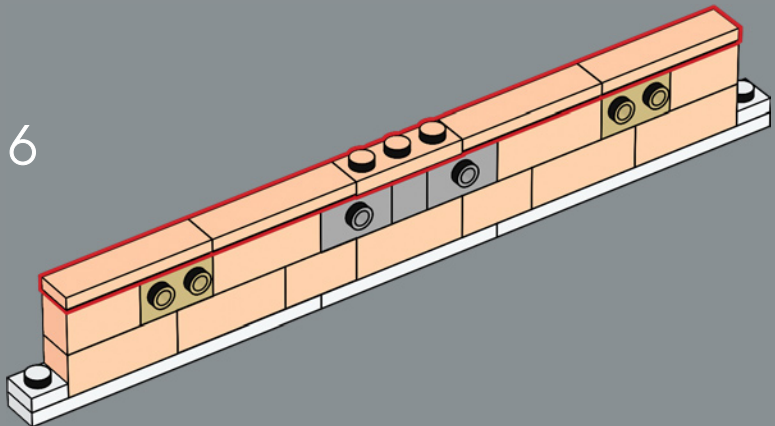

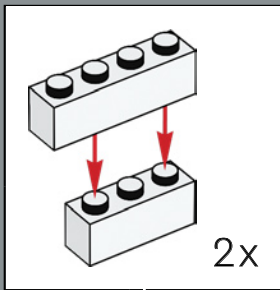
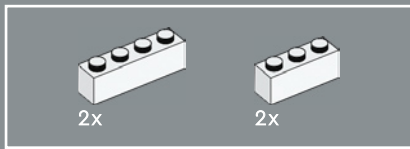

295

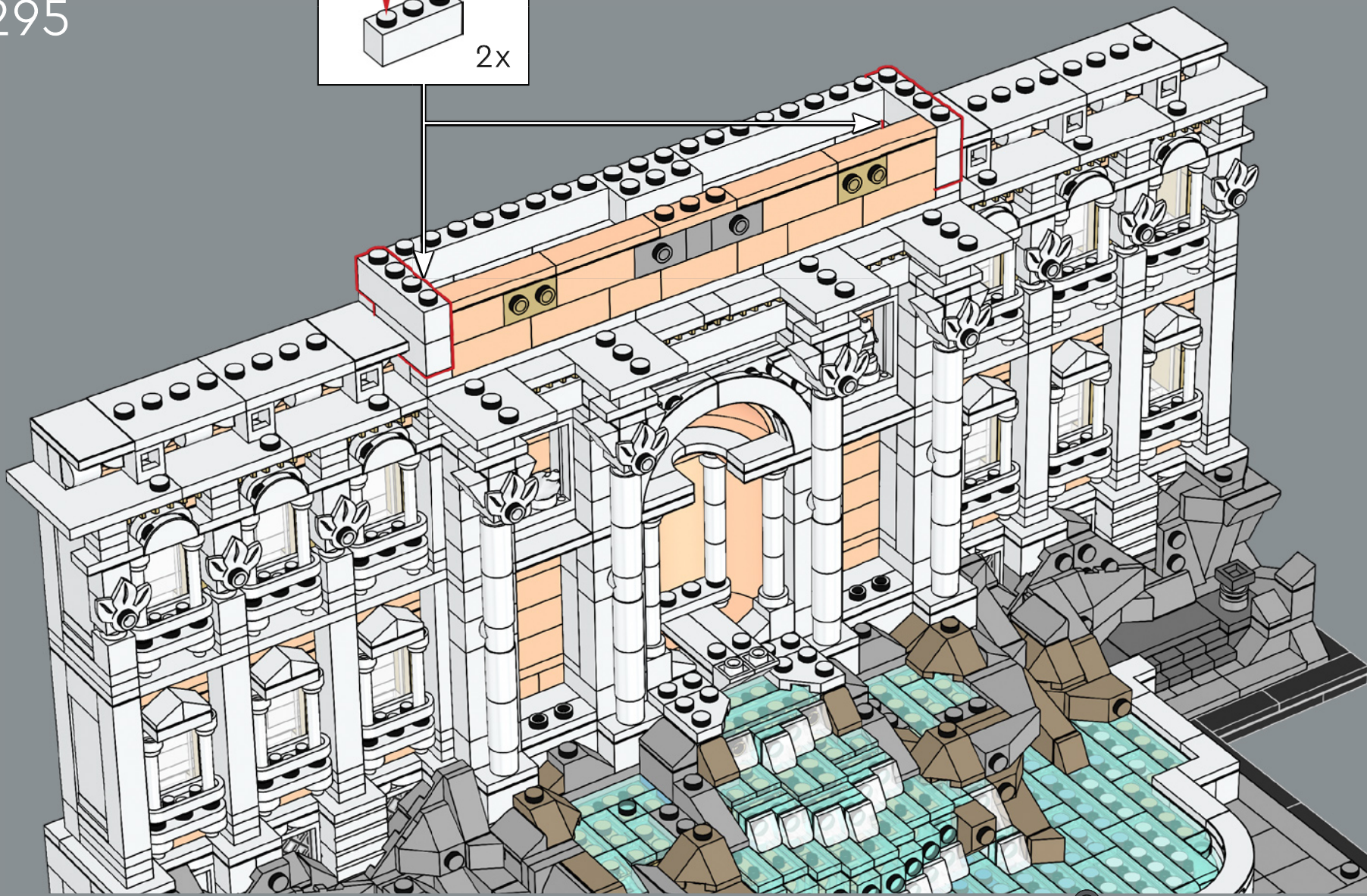

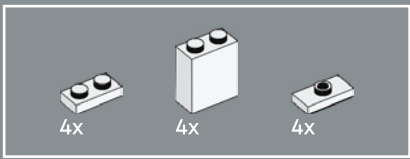

296

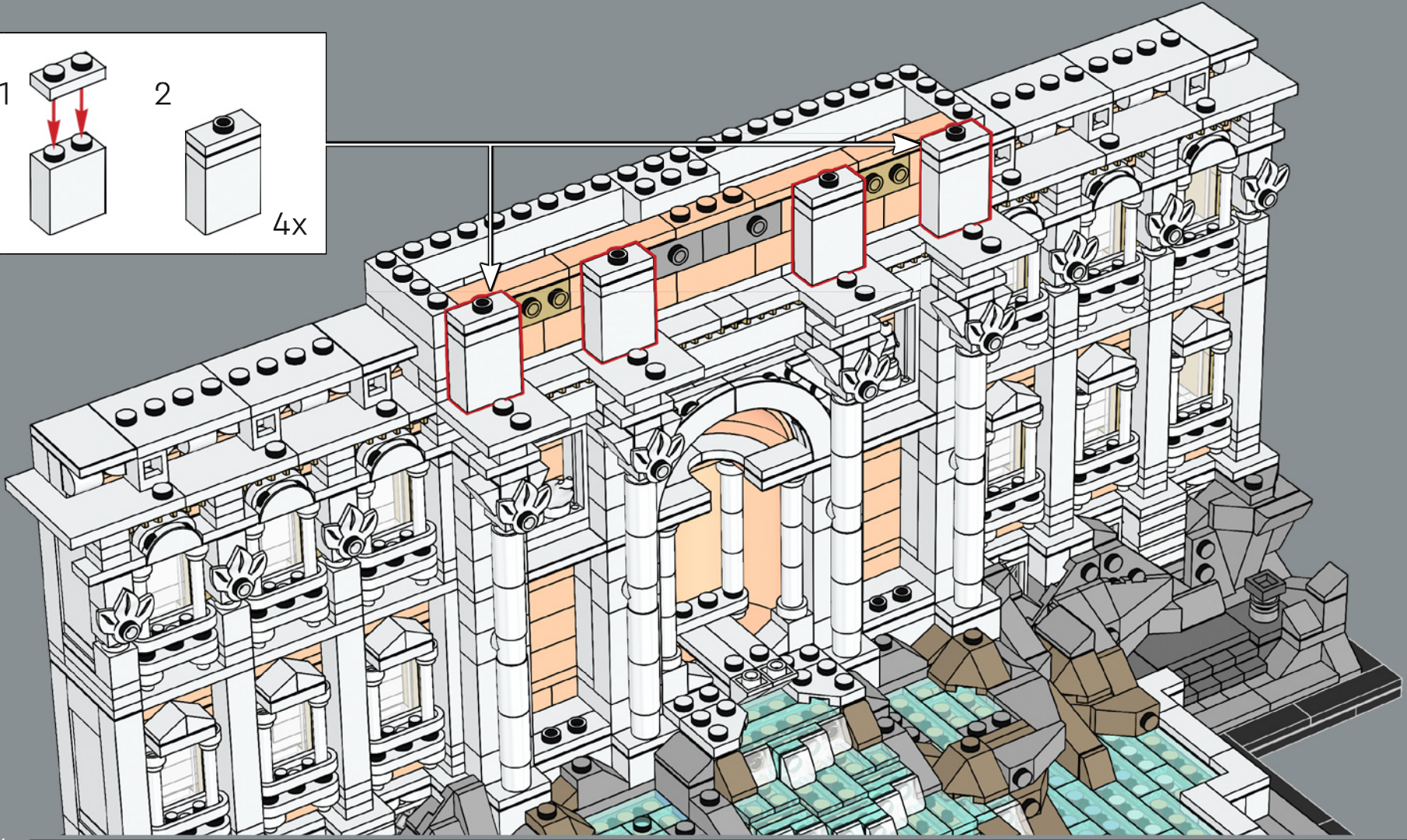
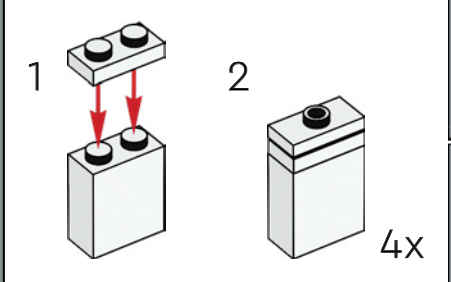

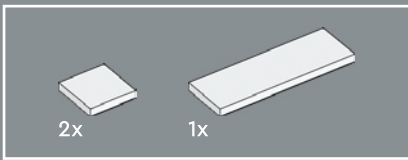

297

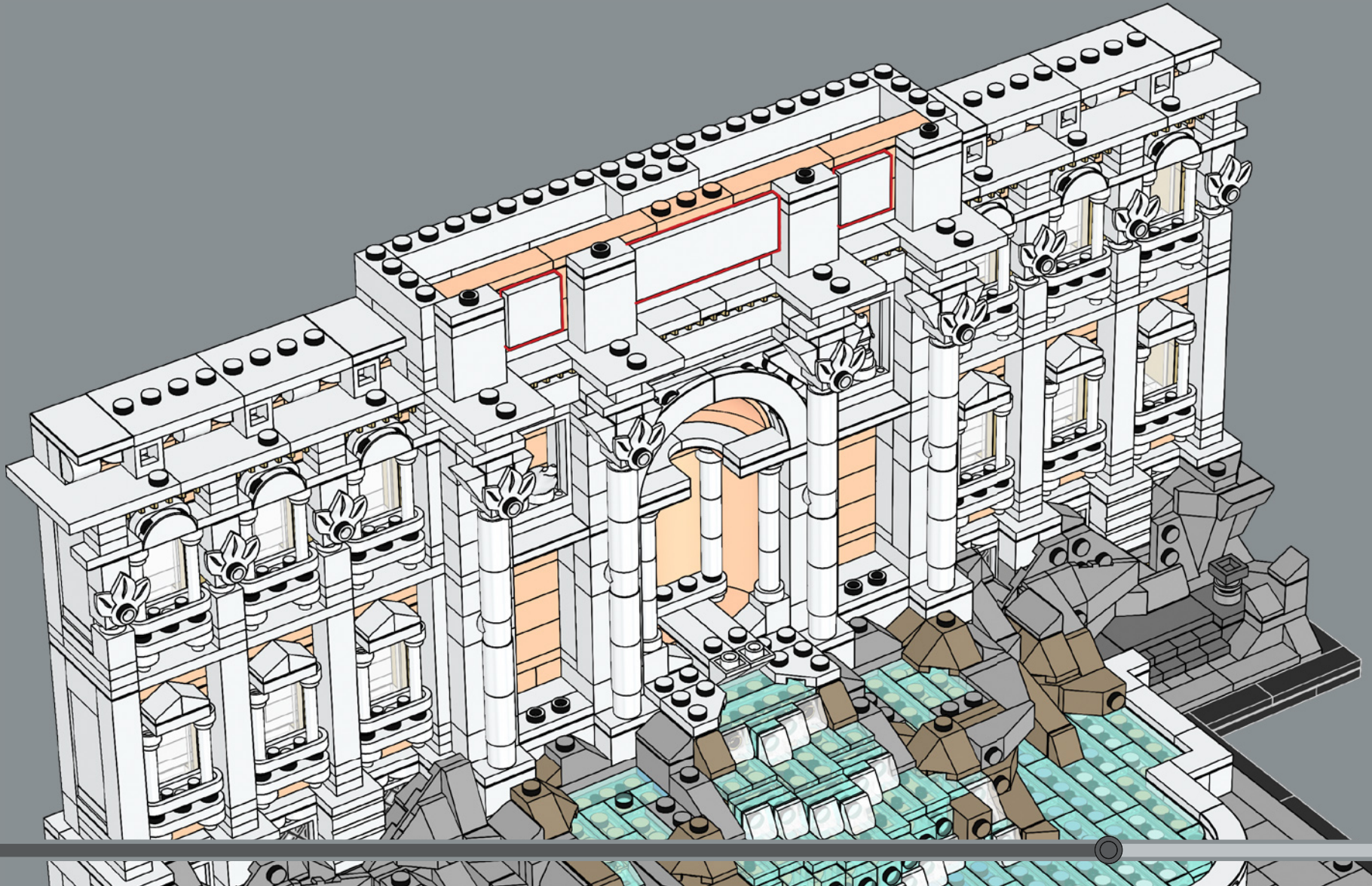

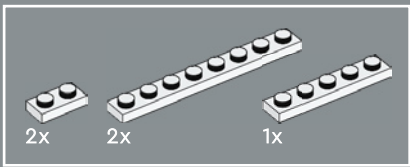

298

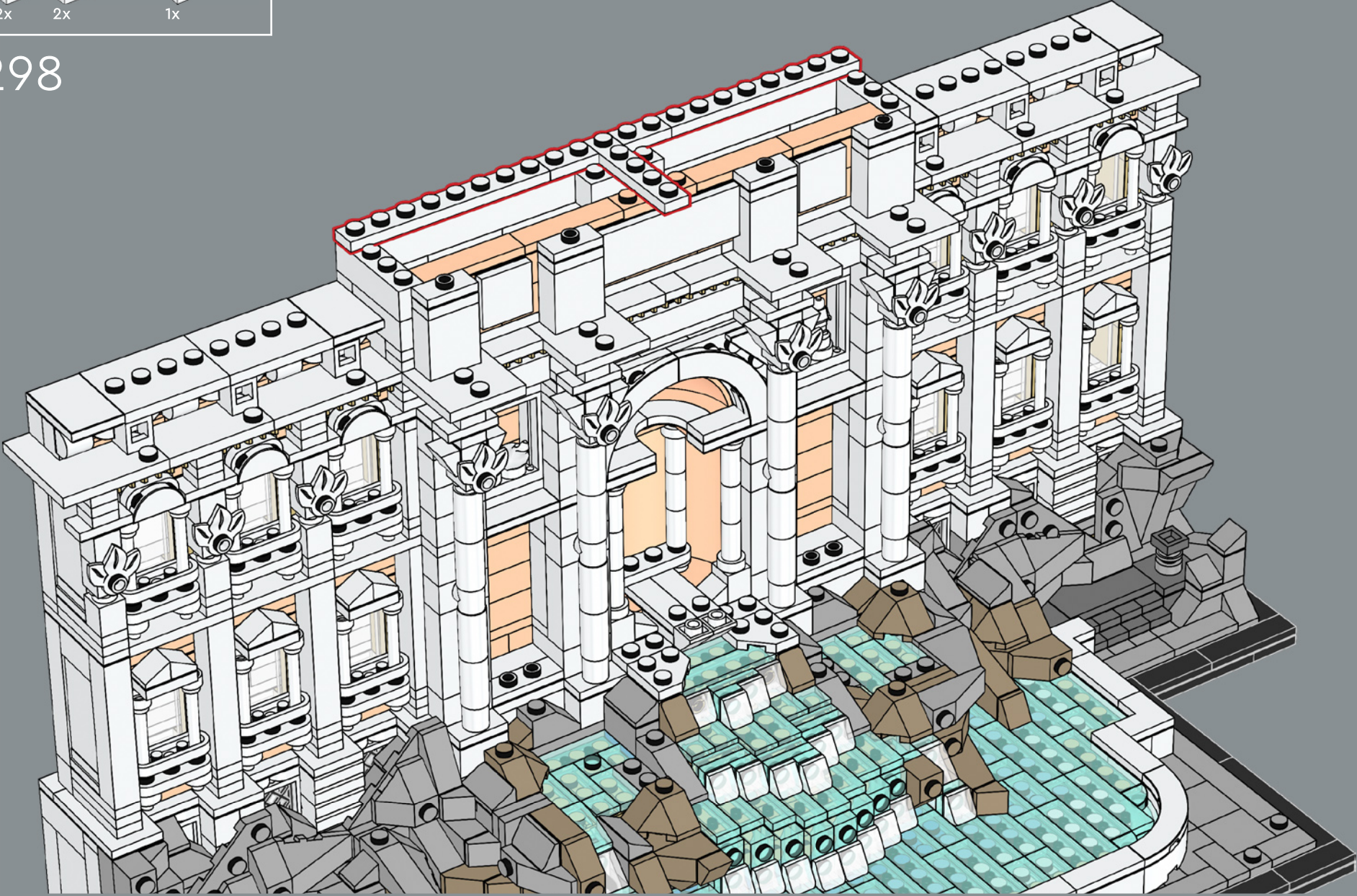

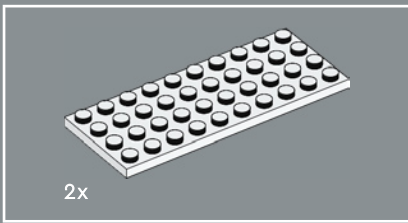

299

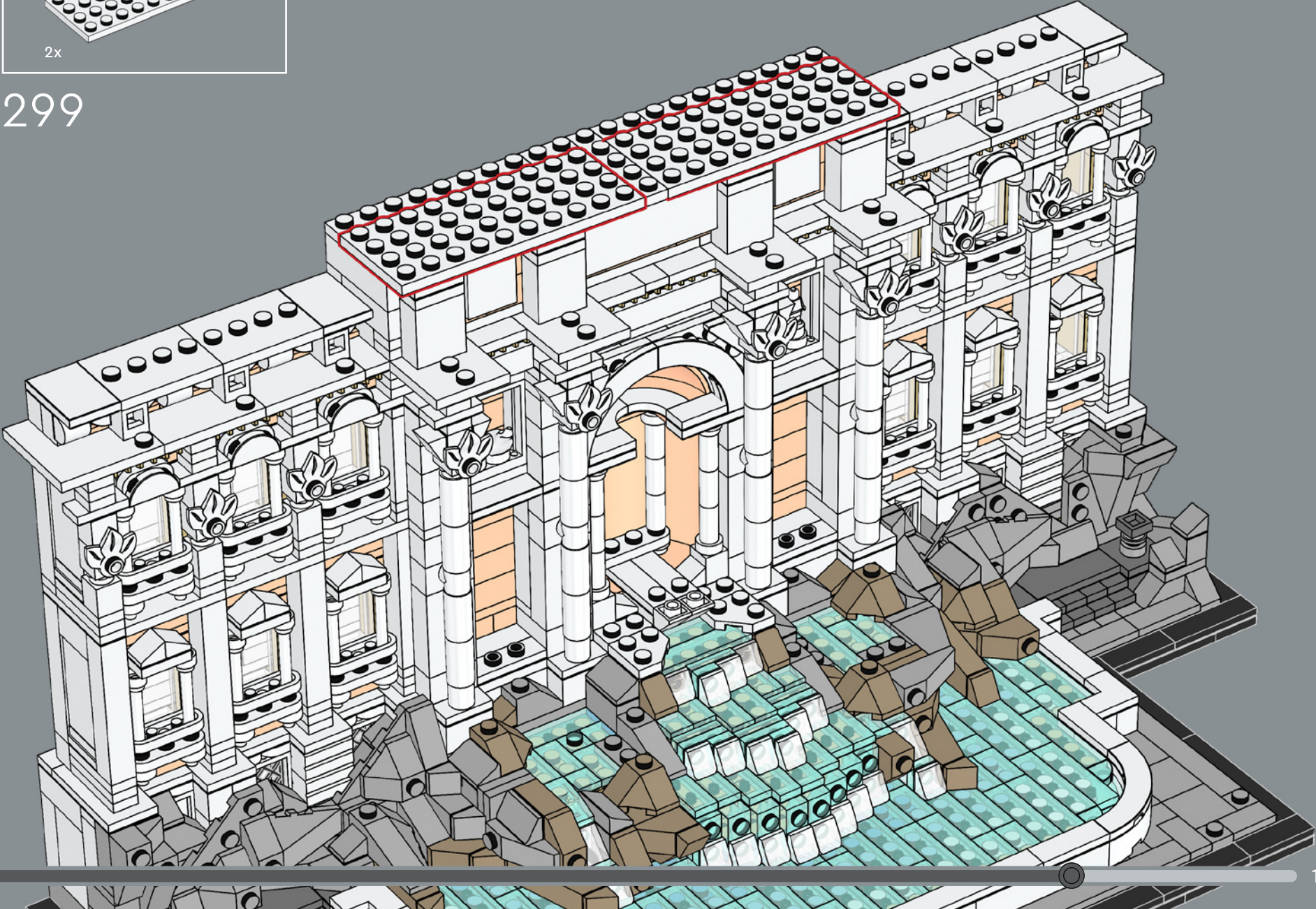

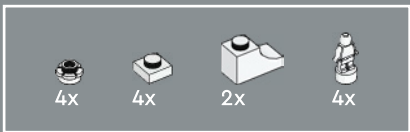

Ces statues représentent les quatre saisons :
L'abondance de fruits, la fertilité des champs, la richesse
de l'automne et l'aménagement des prés et des jardins.

300

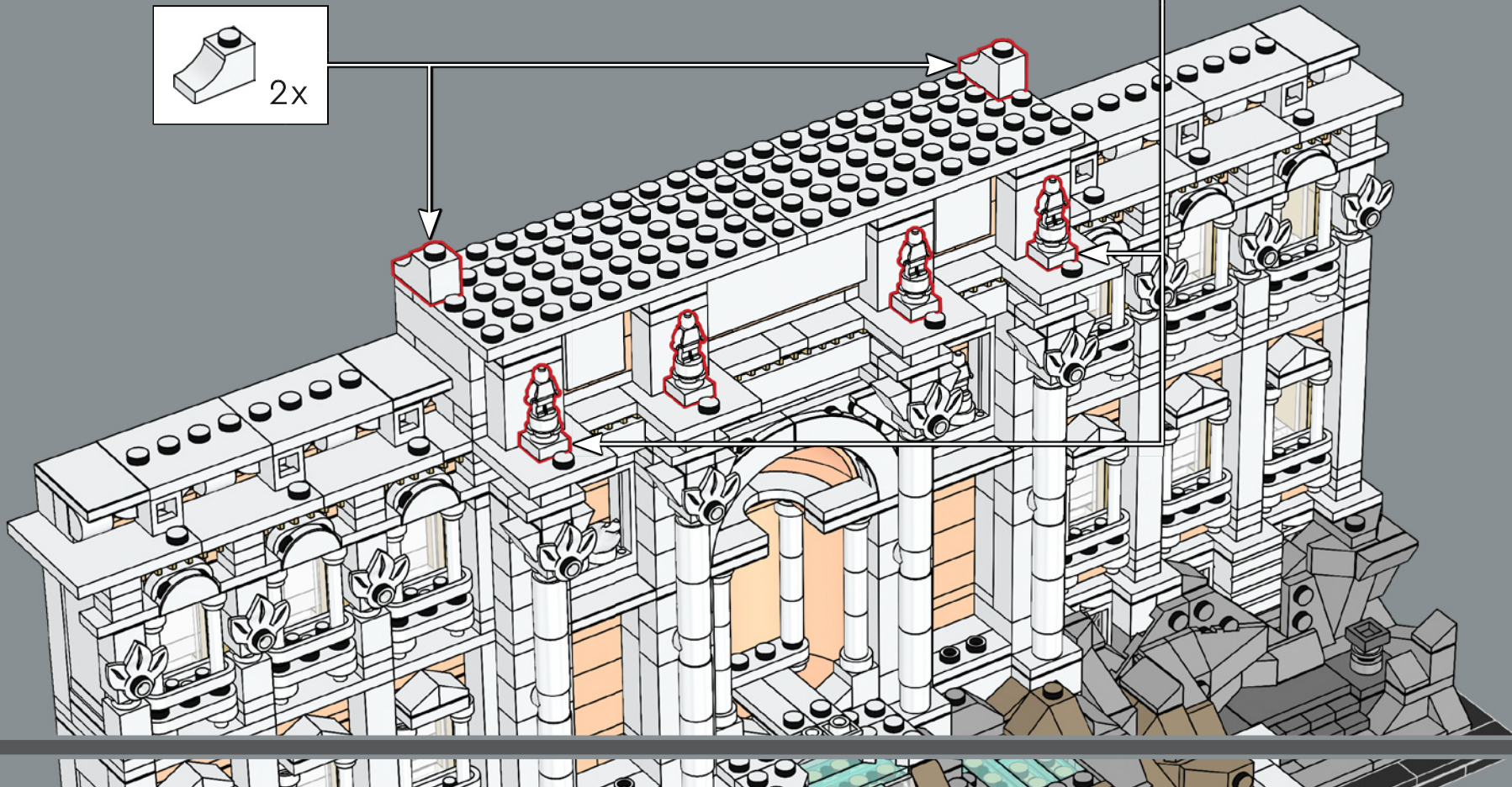
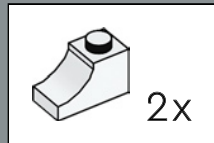
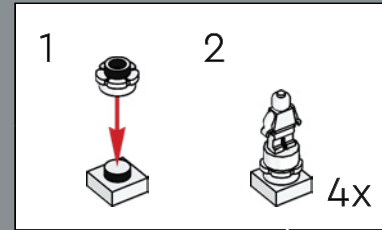

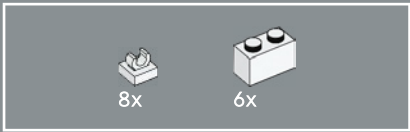

301

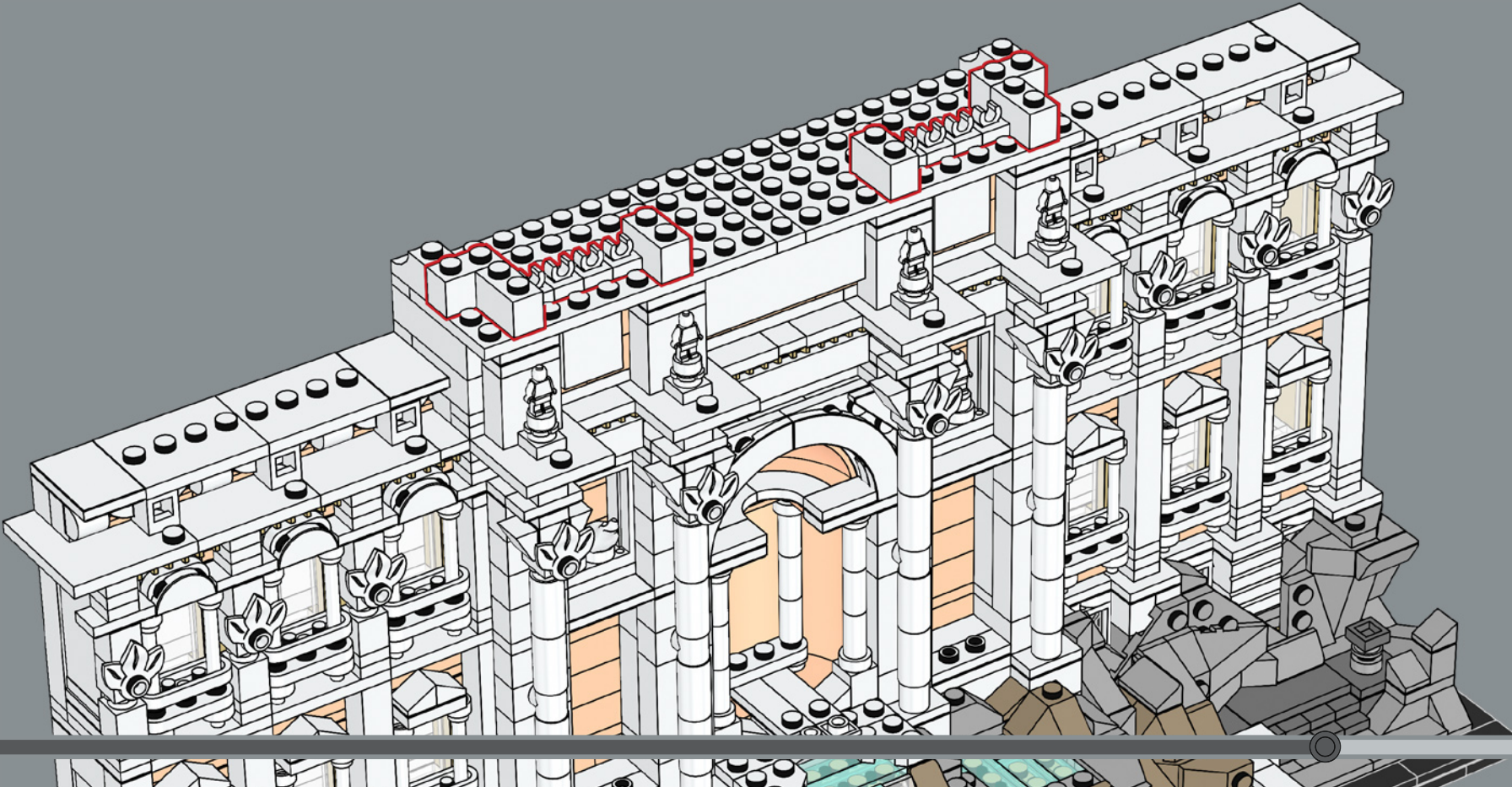

2x 1x 2x

302

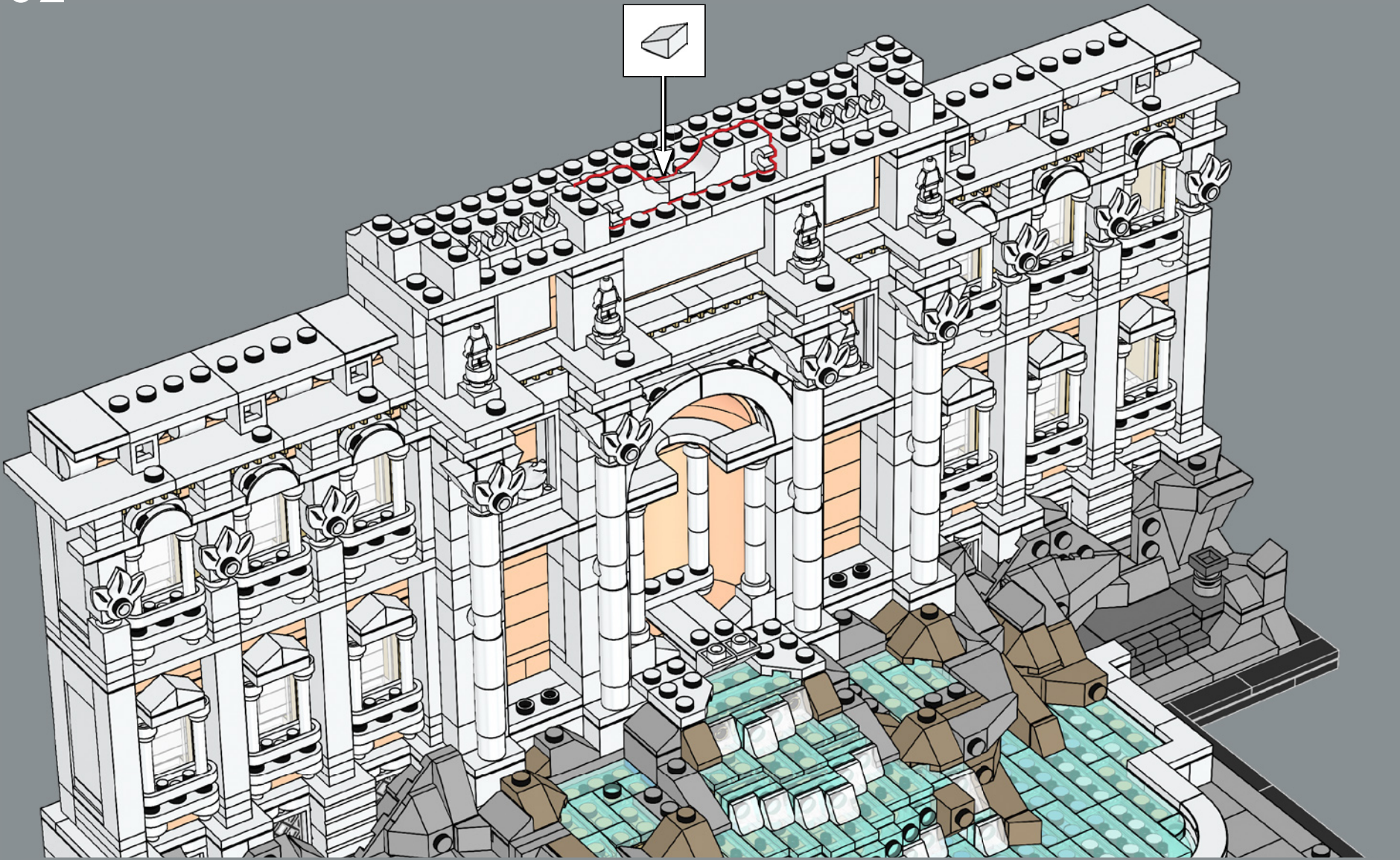
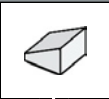

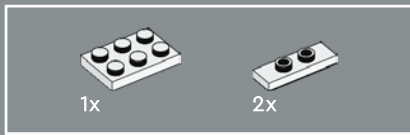

303

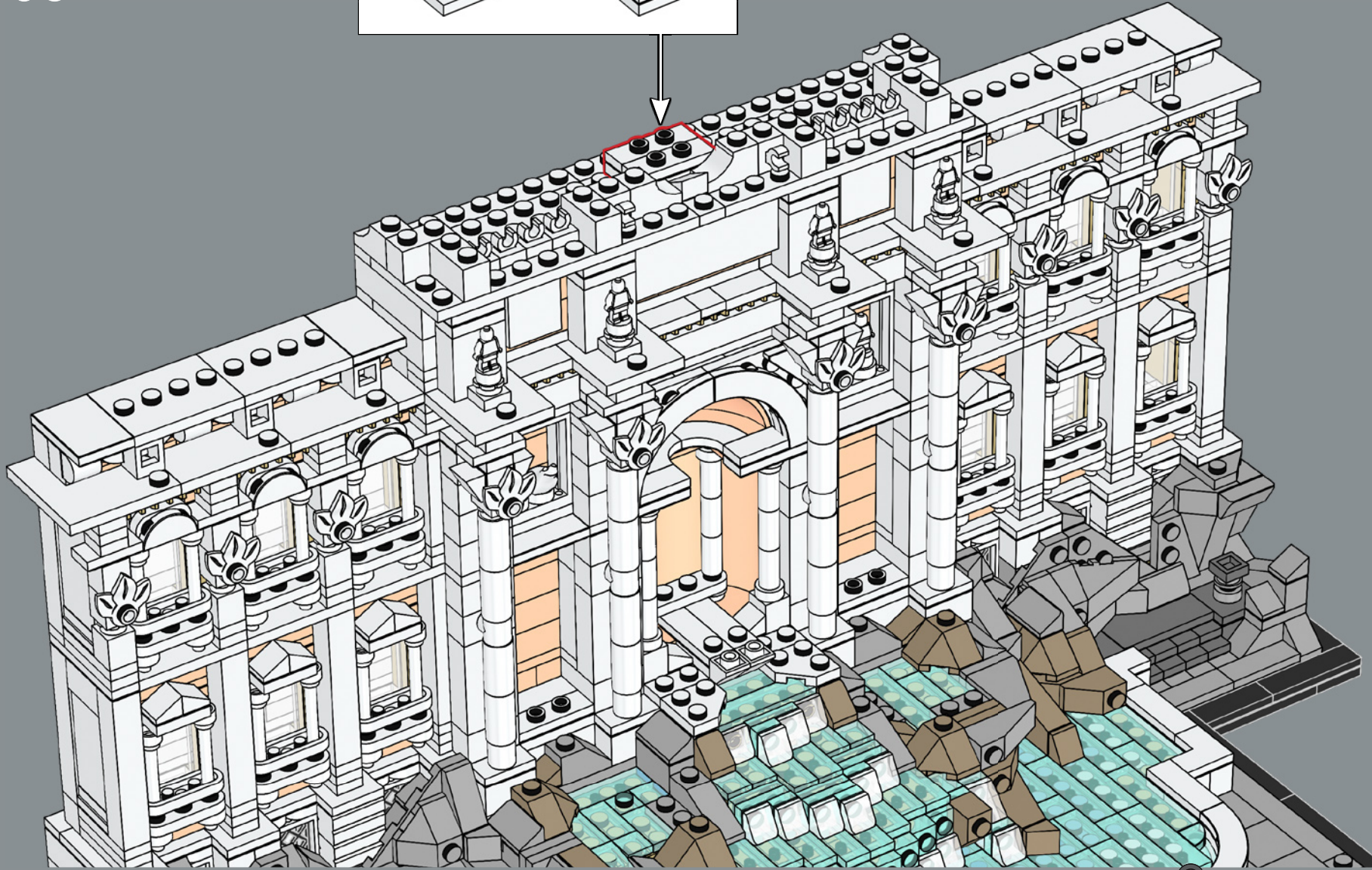
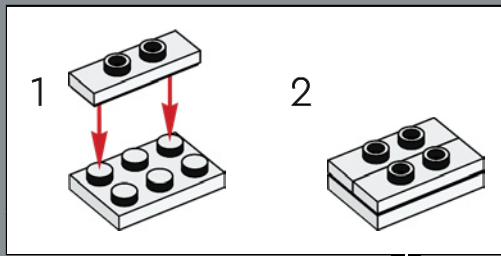

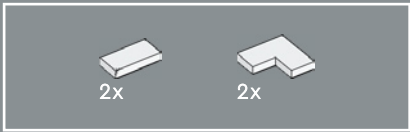

304

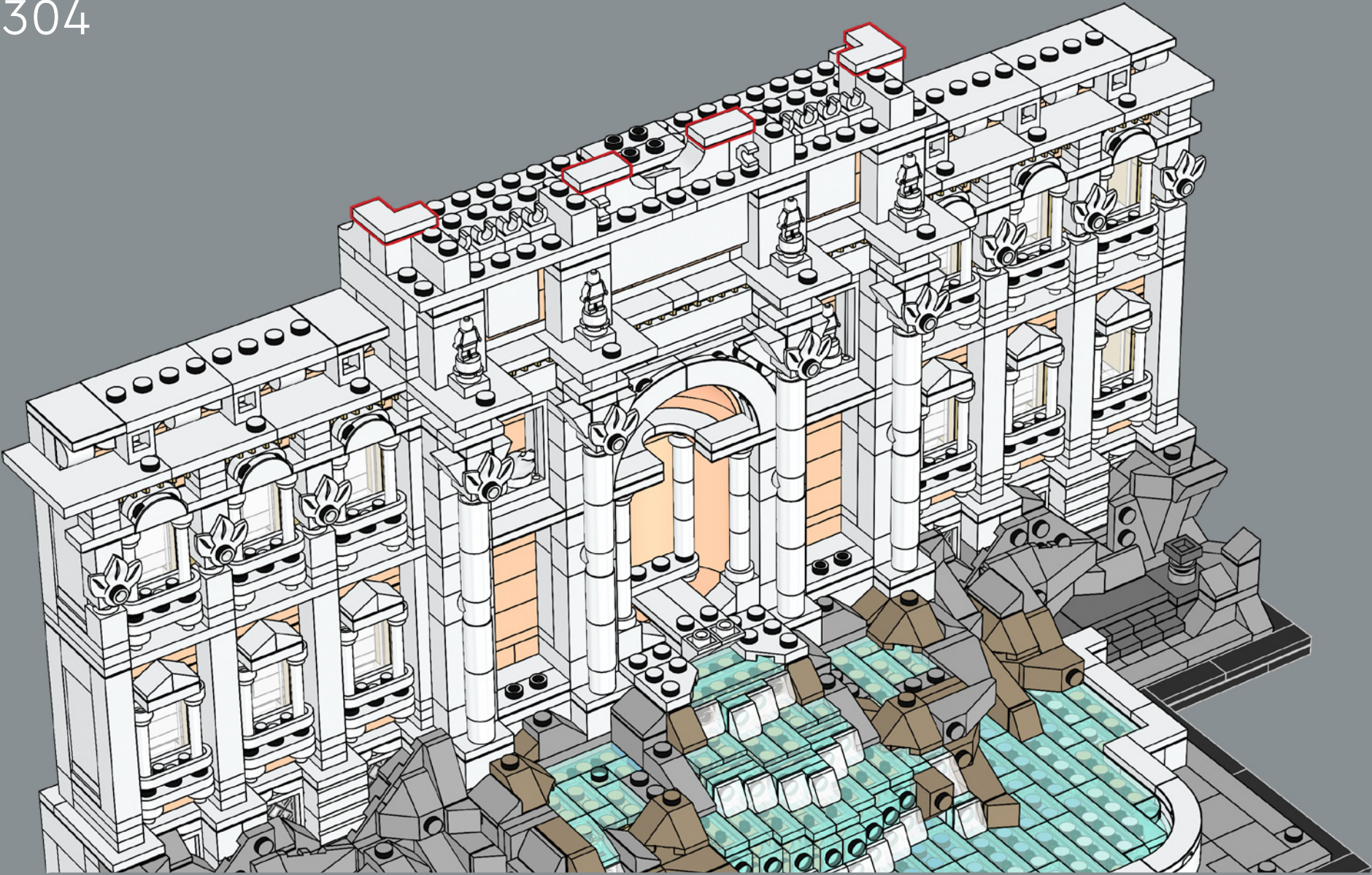

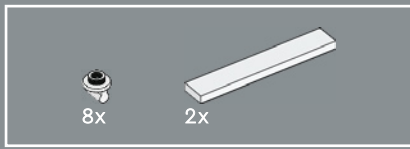

305

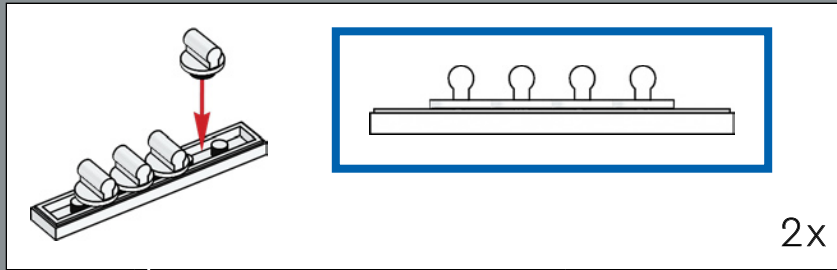

Des clips et des barres LEGO® sont combinés pour créer les colonnes ornementales de la balustrade supérieure.

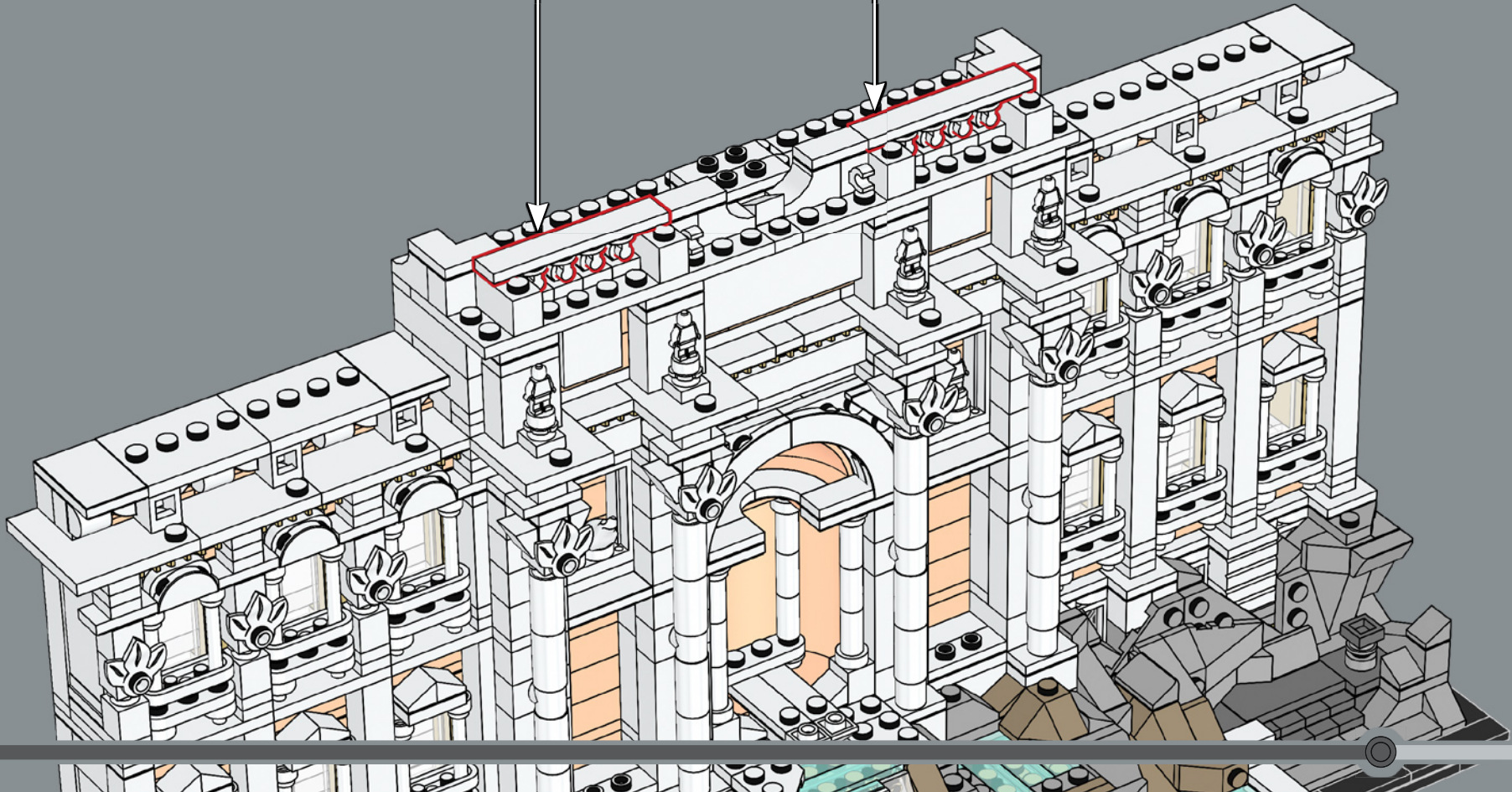

4x  2x 

306

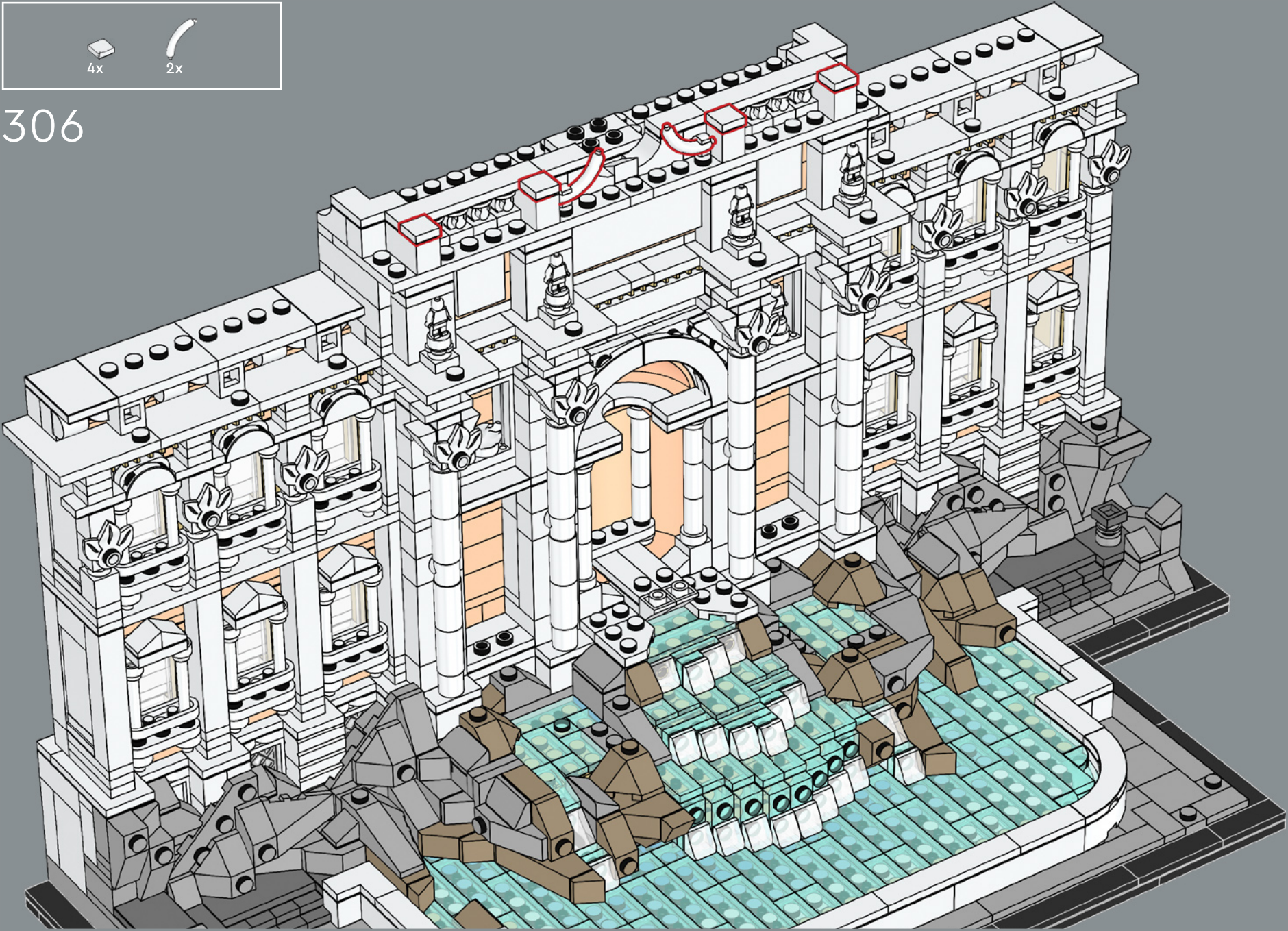

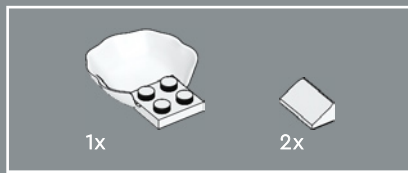

307



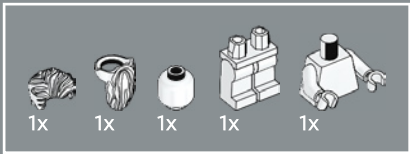

308

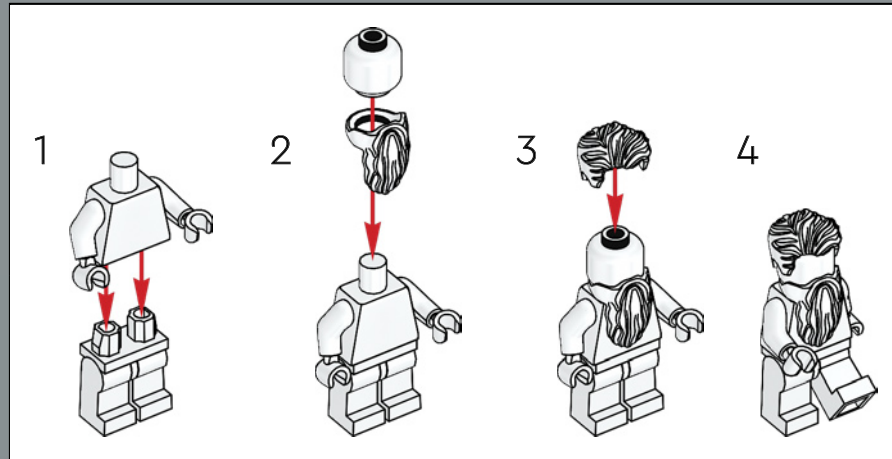

C'est la première fois qu'une minifigurine apparaît dans un set LEGO® Architecture.

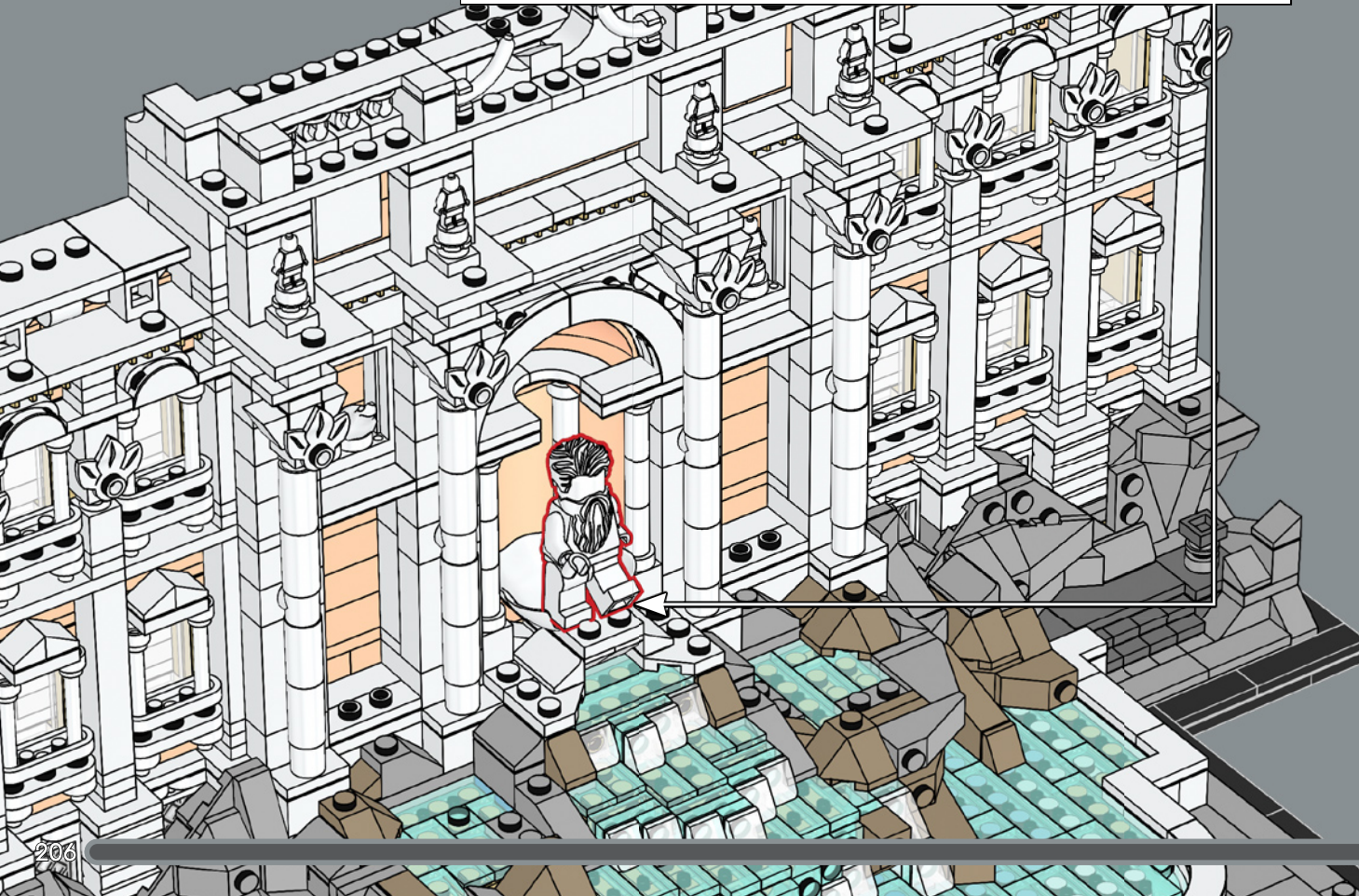

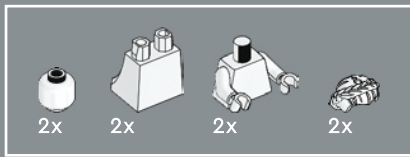

309

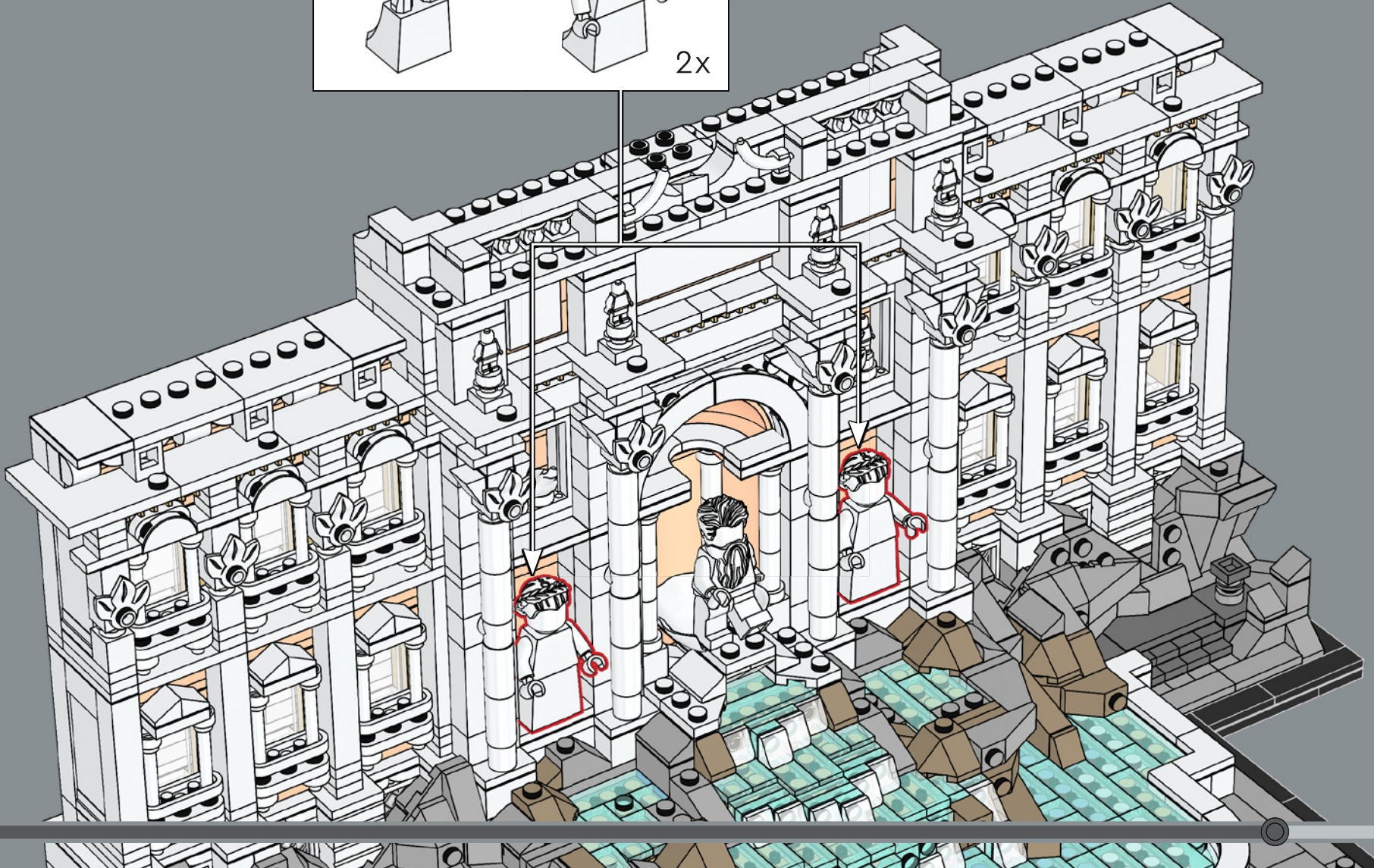
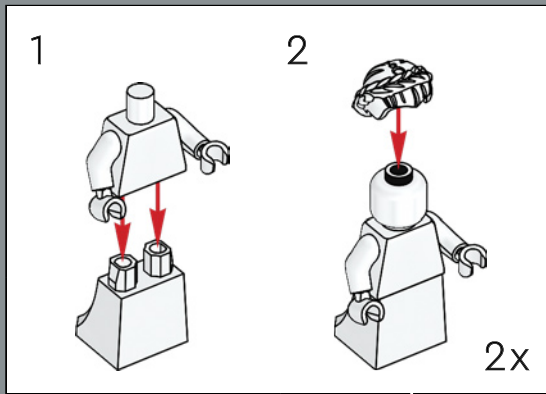

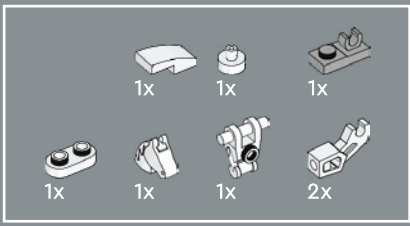

310

La tête de cheval LEGO®, utilisée précédemment dans une série de minifigurines LEGO à collectionner, revient pour compléter les hippocampes, ou chevaux de mer mythiques.

1



2

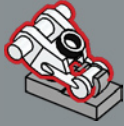

3

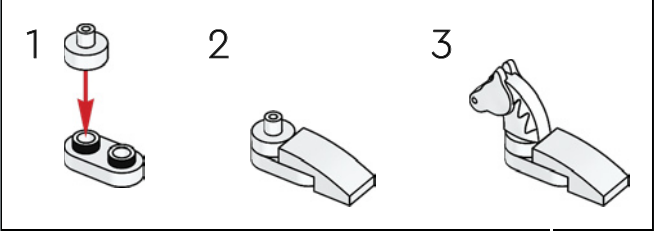
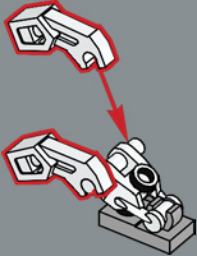

4

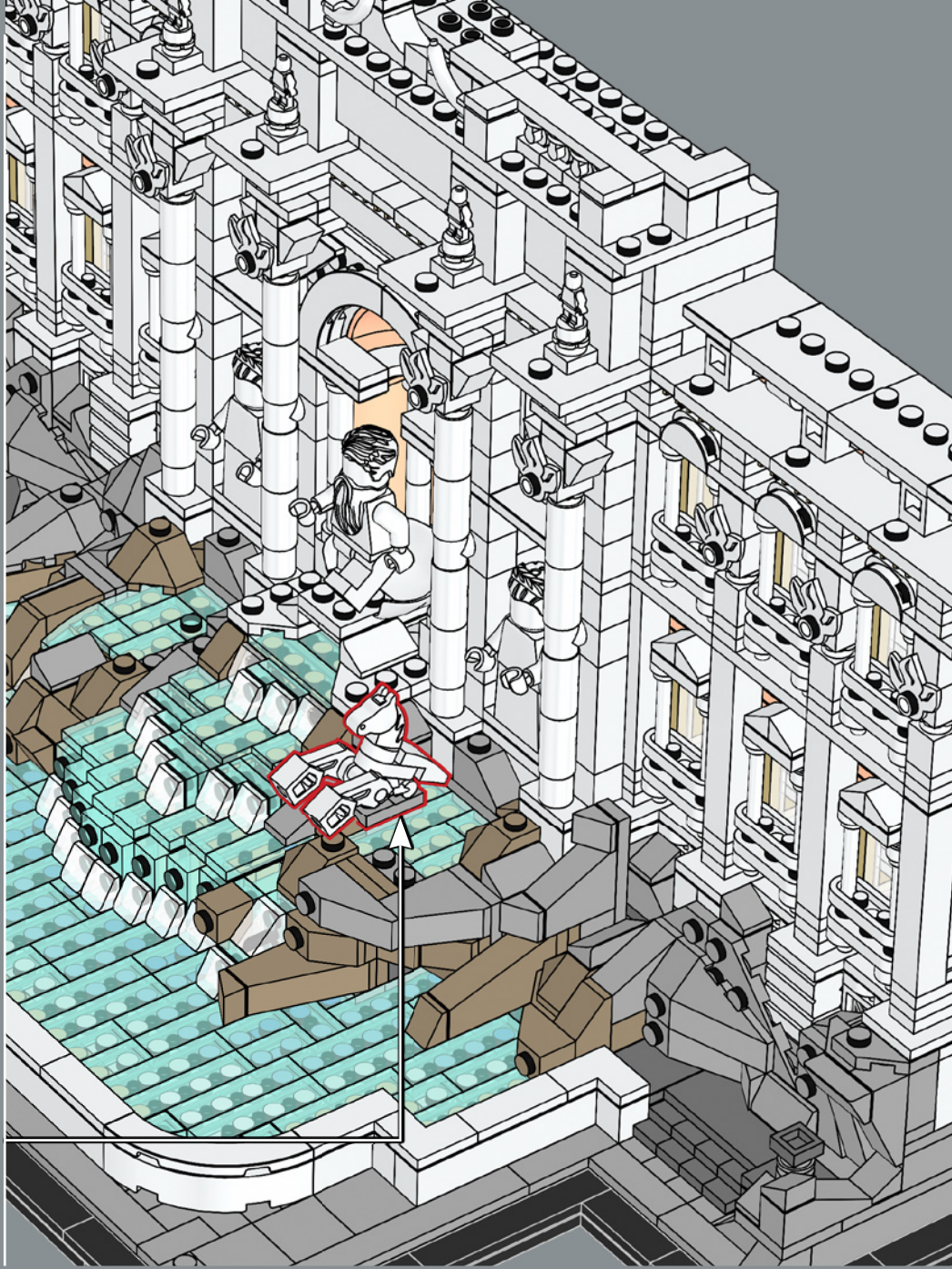
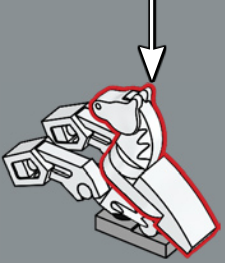



311

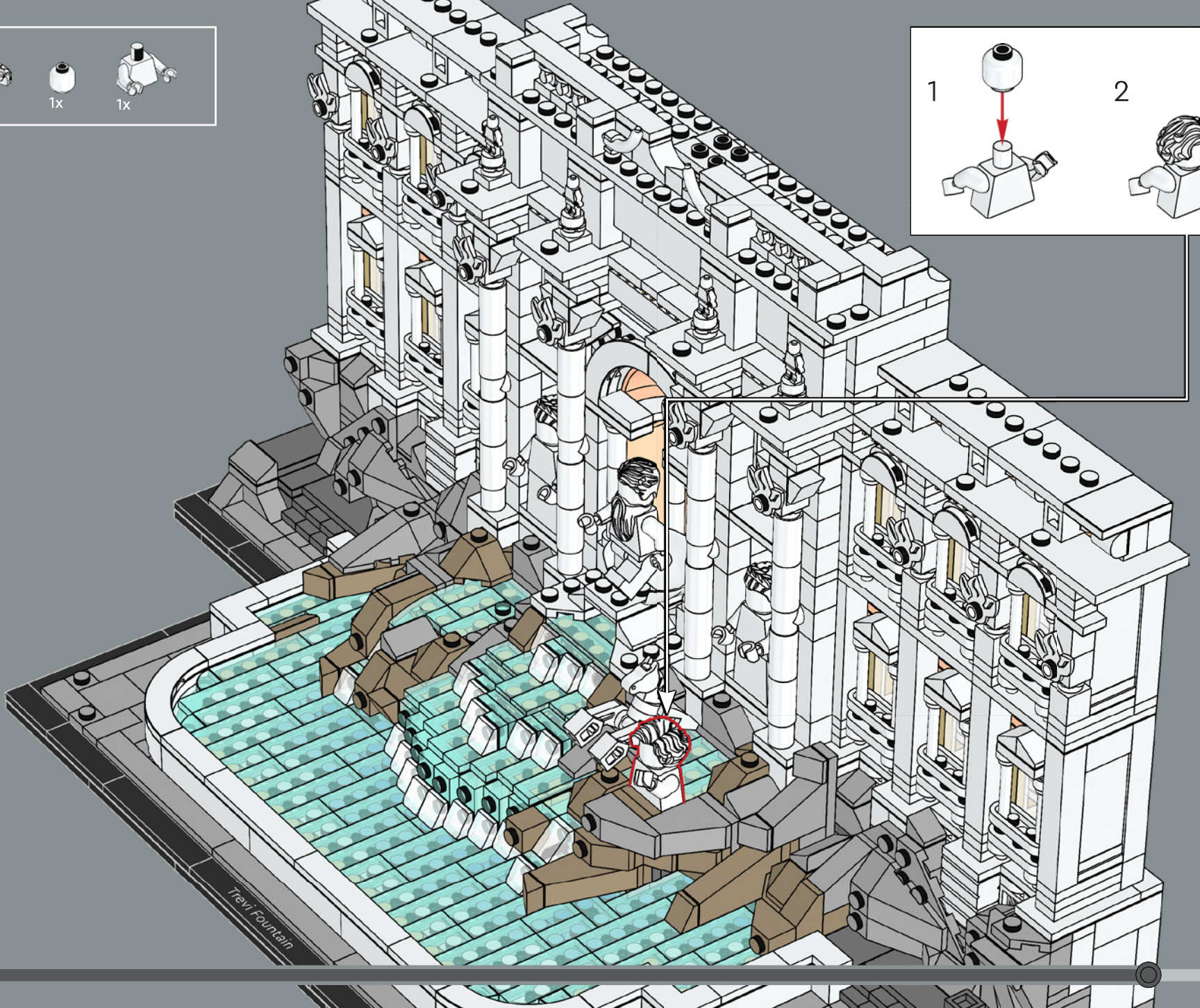
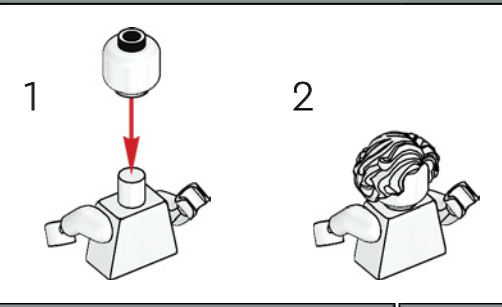



312

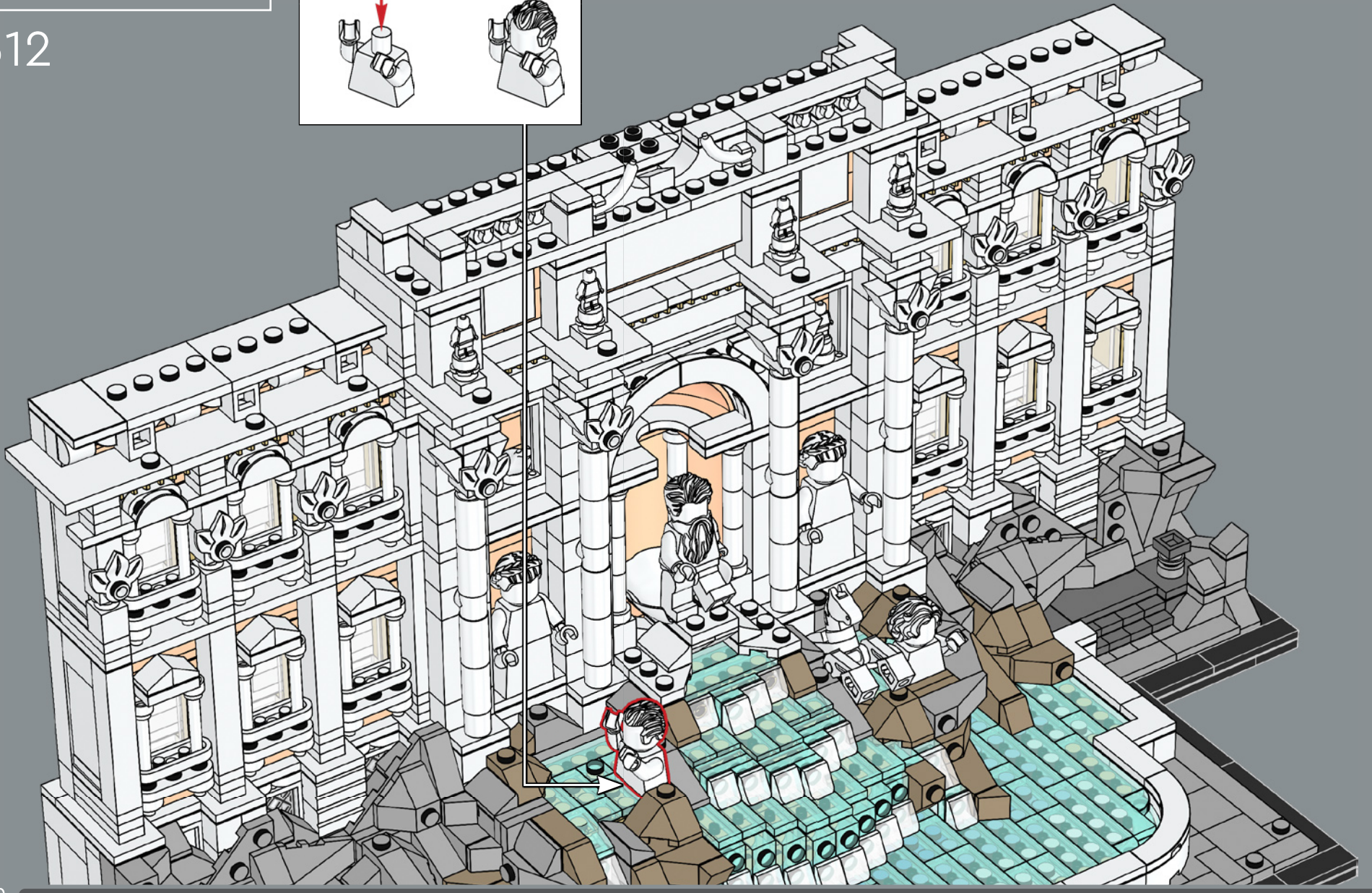
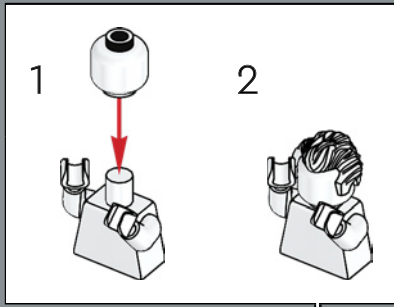

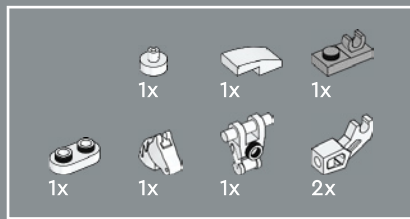

313

1



2

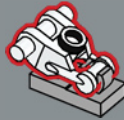

3

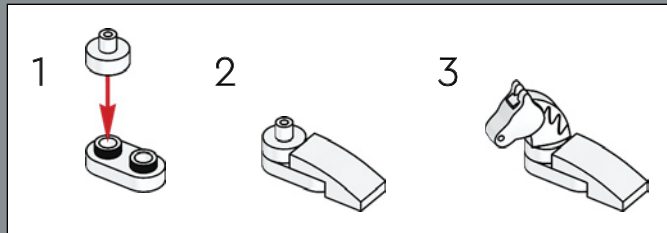
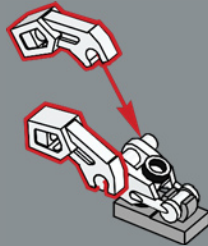

4

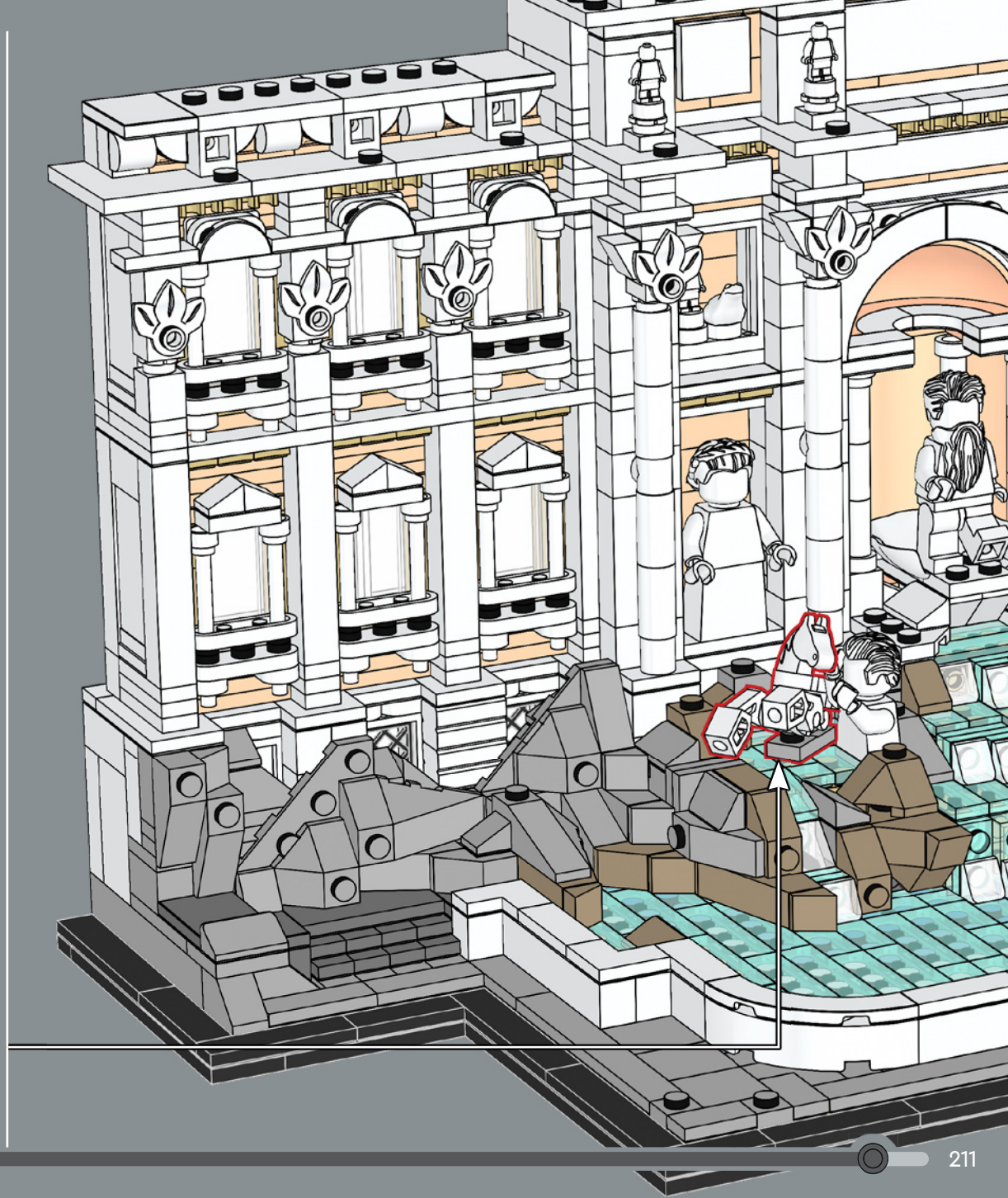
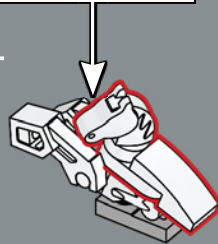

2x 2x

314

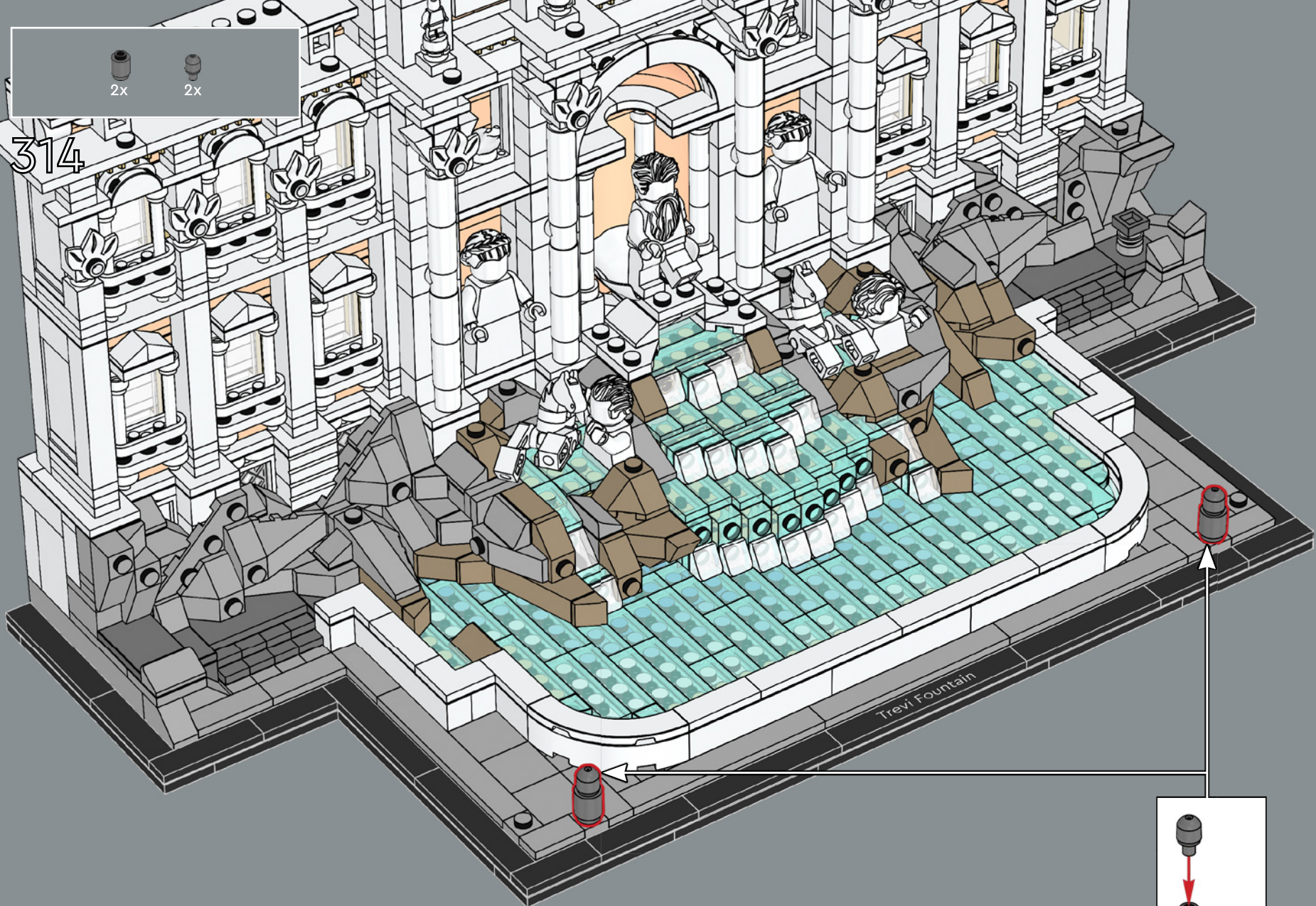

2x

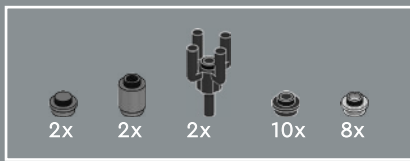

315

1

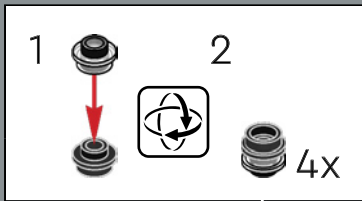
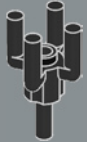

2

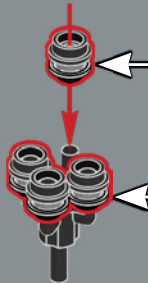

3

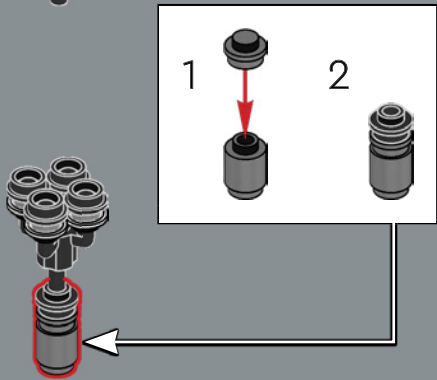

2x

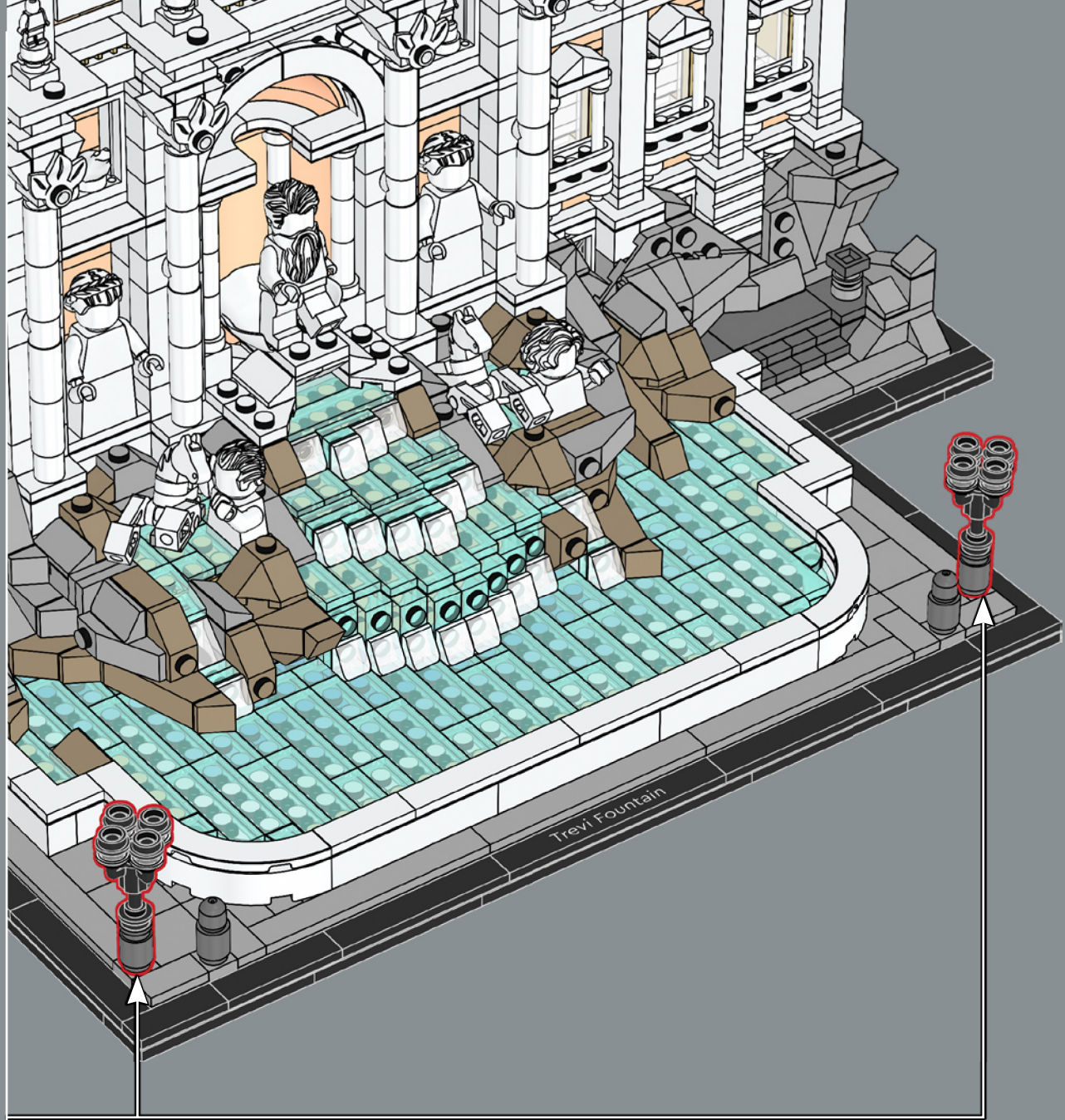

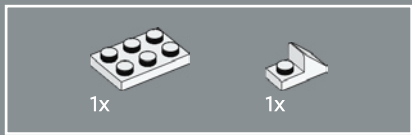

316

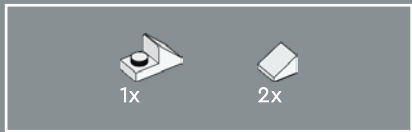
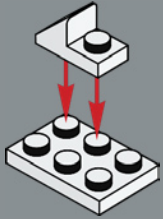

317

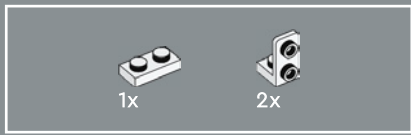
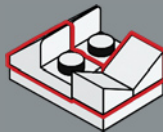

318

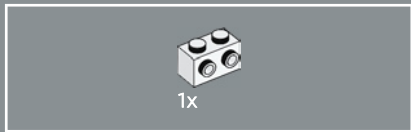
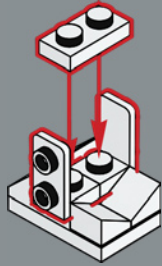

319

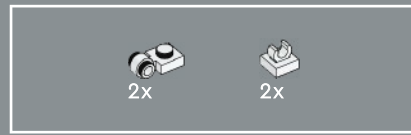
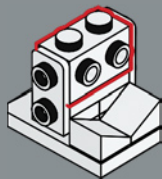

320

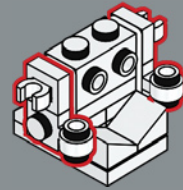

321

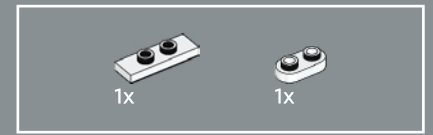
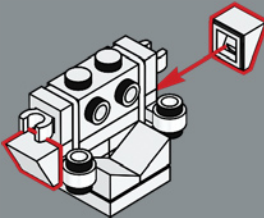

322

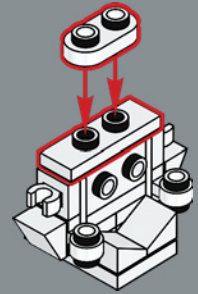

323

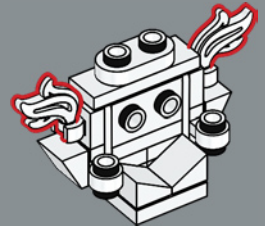



2x

324

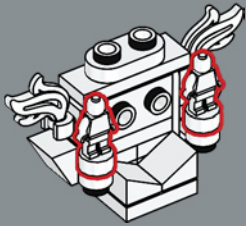

1x

325

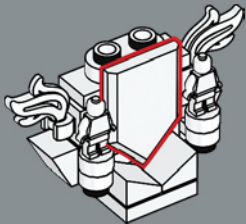

2x

326

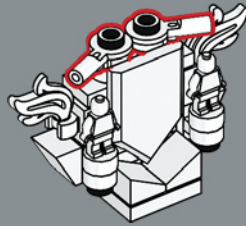

1x



1x

327

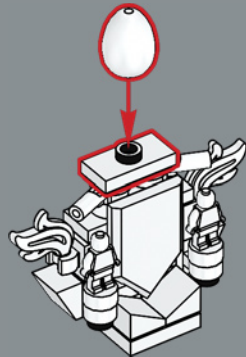

328

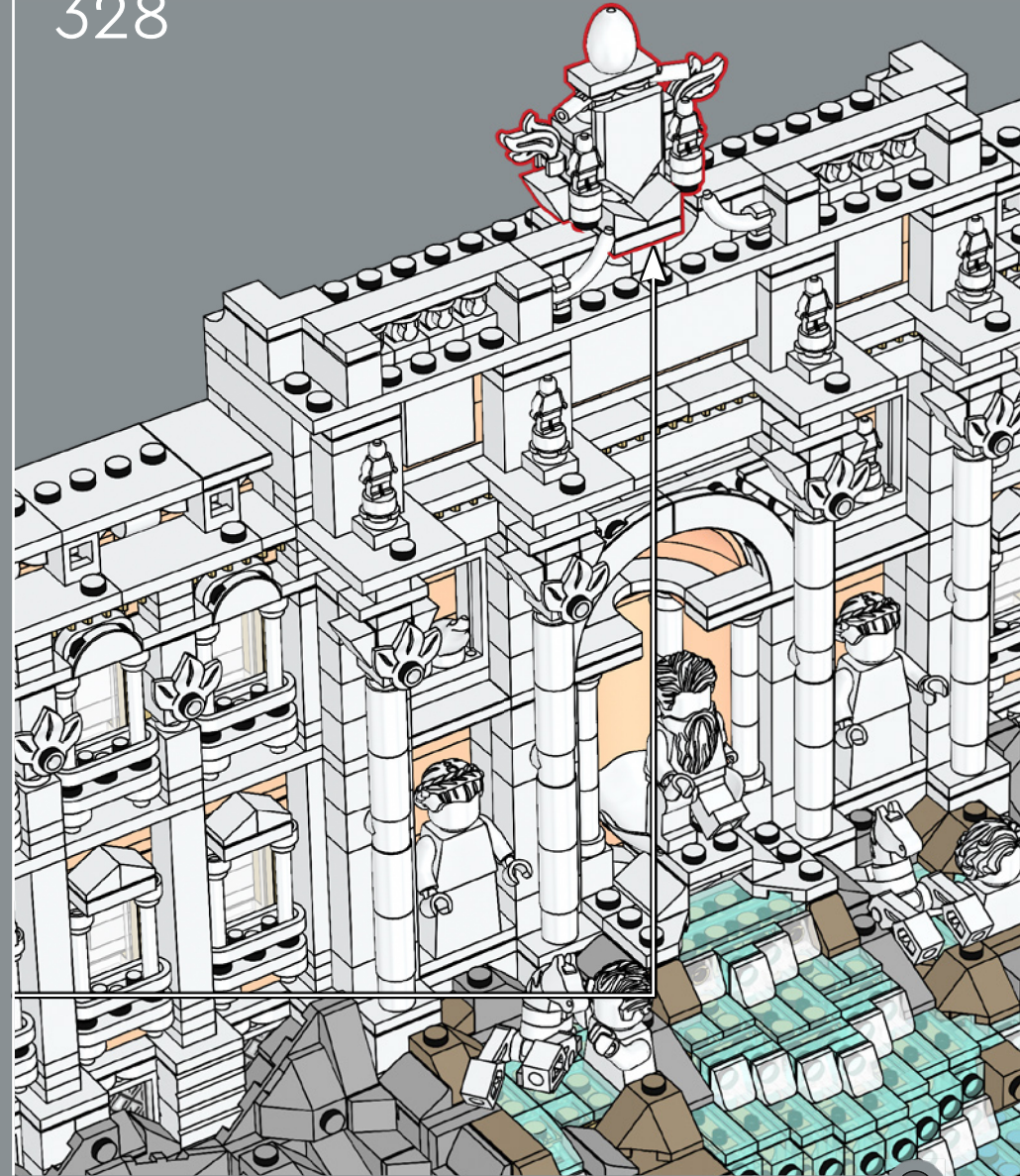

La fontaine de Trevi, sculptée en travertin, a servi de décor à de nombreux films dont *La Dolce Vita* de Federico Fellini (1960).

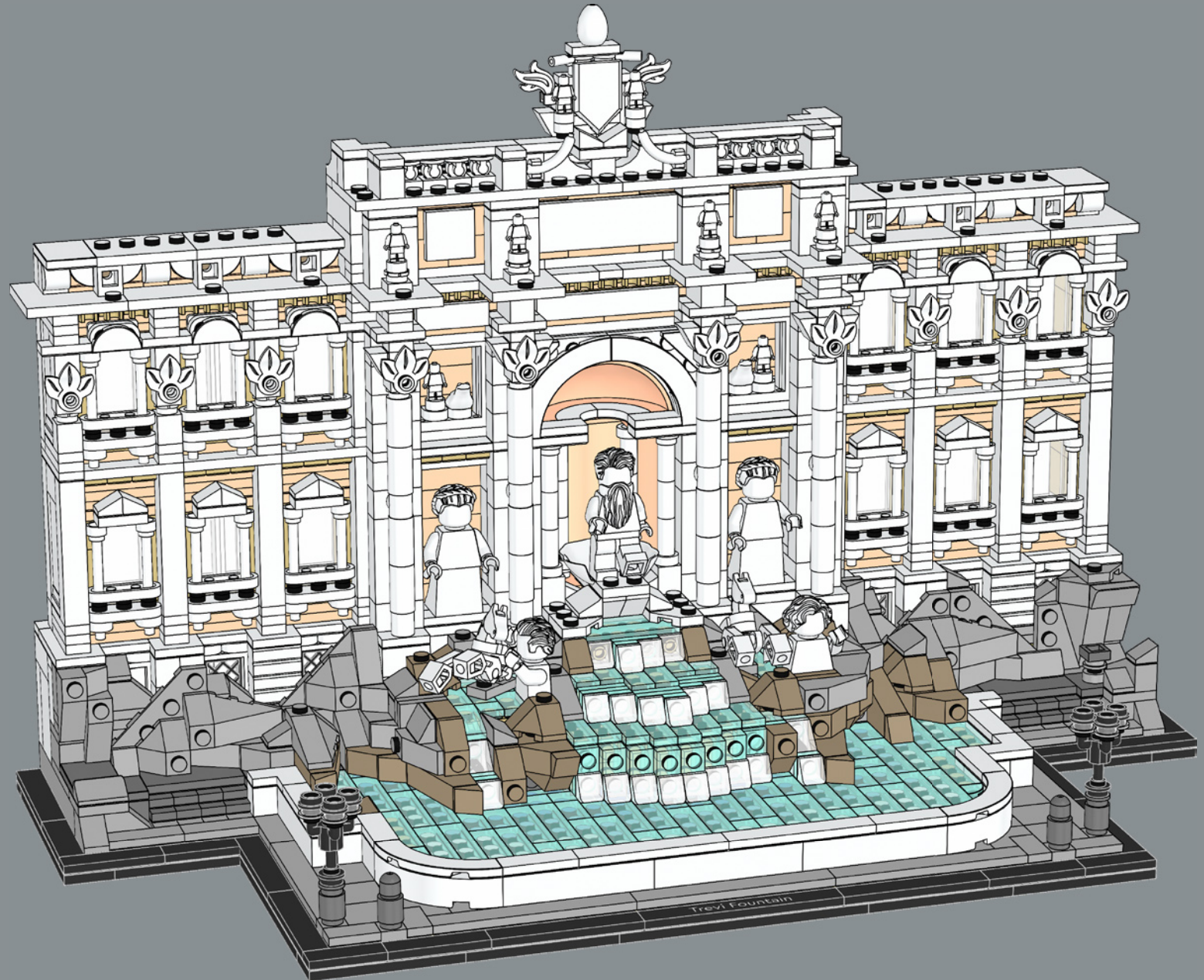

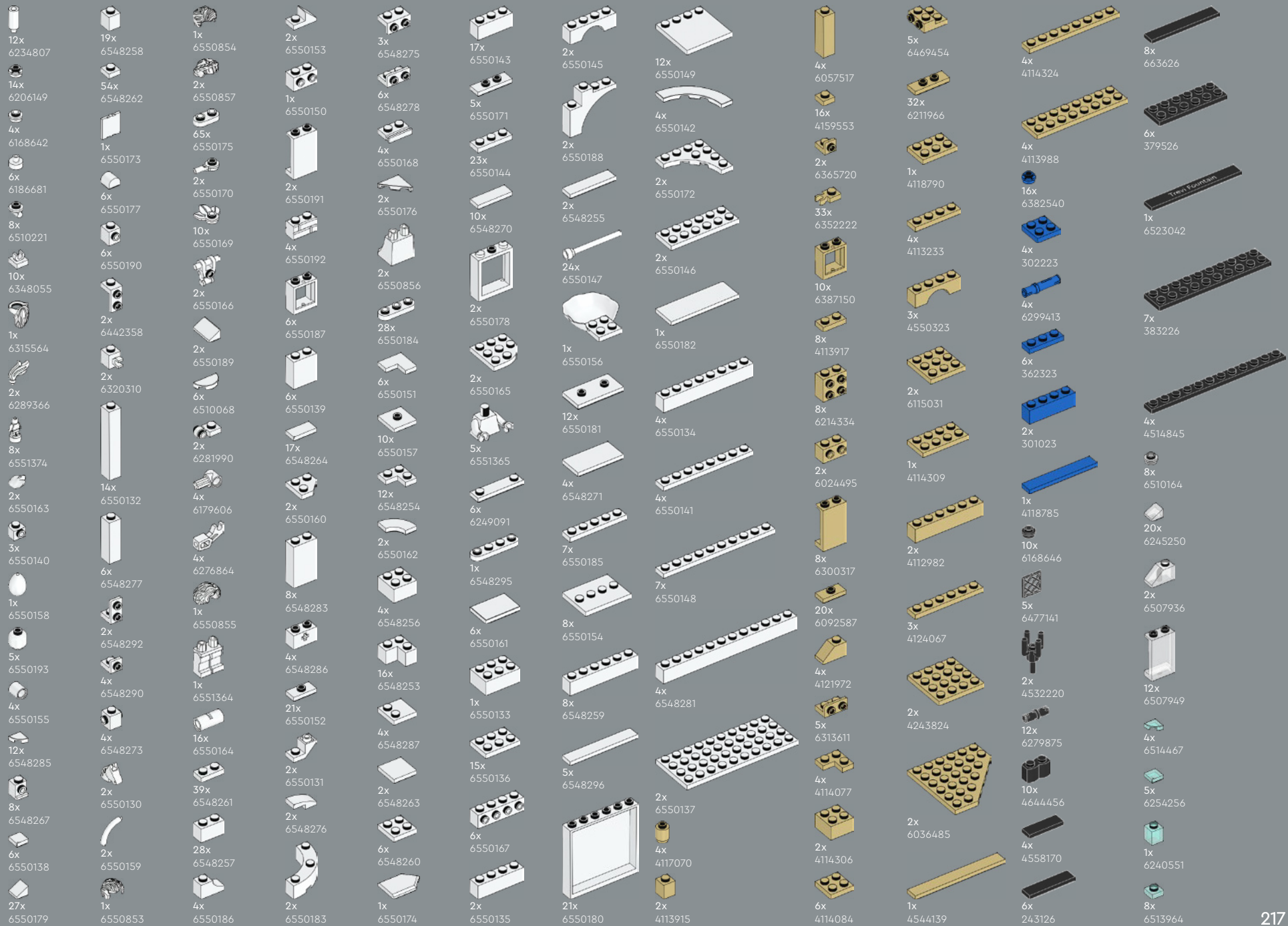

- 2x 6537848
- 14x 6514007
- 39x 6514224
- 6x 6514268
- 1x 6508249
- 54x 6510178
- 1x 6240515
- 10x 6322841
- 4x 6001824
- 9x 4530678
- 5x 4528604
- 4x 4653509
- 1x 6449563
- 1x 4521914
- 2x 6093064
- 1x 6228921
- 7x 6331865
- 2x 6035540
- 10x 6040126
- 1x 6015449
- 1x 6168647
- 1x 6258831
- 3x 4211389
- 19x 4521921
- 3x 6225242
- 6x 4211399
- 8x 4211415
- 4x 4558953
- 6x 6248890
- 1x 4211791
- 10x 4568637
- 1x 6213378
- 1x 6186657
- 3x 6123809
- 4x 4515374
- 11x 4211614
- 4x 6066097
- 9x 4211414
- 4x 4211388
- 1x 6093859
- 1x 4211564
- 5x 4211398
- 2x 6326078
- 2x 6383177
- 1x 6217876
- 1x 4211349
- 2x 6177078
- 6x 4211413
- 2x 6034676
- 8x 6212077
- 11x 4211353
- 2x 6469440
- 11x 4211488
- 6x 4558169
- 8x 6211969
- 4x 4211396
- 4x 4160560
- 7x 4211445
- 1x 4180418
- 3x 4180408
- 1x 6372029
- 1x 4211438
- 6x 4211452
- 2x 4211795
- 7x 4211425
- 2x 4211392
- 5x 4211481
- 1x 6313653
- 5x 4211404
- 1x 4210719
- 16x 6092572
- 4x 4210978
- 1x 6126083
- 2x 6309059
- 2x 4211133
- 1x 4211104
- 2x 6343852
- 8x 6187008
- 2x 4211105
- 4x 4211001
- 2x 4560184
- 3x 4620760
- 2x 4211002
- 2x 4211498
- 2x 4251149
- 5x 4617862
- 4x 4211408
- 2x 4211360
- 2x 4662161
- 1x 6528242
- 2x 6344216
- 4x 4211090
- 2x 4210633
- 4x 6395635
- 1x 6228923
- 4x 4558955
- 2x 4211107
- 2x 4211061
- 2x 4210678
- 4x 6000970
- 16x 6426347
- 4x 6357797
- 6x 6369189
- 16x 6329282
- 4x 6369188
- 21x 6357794
- 10x 6501239
- 4x 6440965
- 12x 6424071
- 1x 6541427
- 1x 6537849
- 12x 6537846
- 2x 6329604
- 4x 6439745
- 8x 6206809
- 4x 6144149
- 4x 4649741
- 2x 6070757
- 8x 4655256
- 2x 6146701
- 6x 6141592
- 2x 6138662



 [LEGO.com/service](https://www.LEGO.com/service)



YOU COULD WIN



YOU COULD WIN

Your feedback will help shape the future development of this product series.

Visit:

DU KÖNNTEST GEWINNEN

Dein Feedback trägt zur Weiterentwicklung dieser Produktreihe bei.

Geh auf:

VOUS POURRIEZ GAGNER

Vos commentaires nous aideront à concevoir les futurs produits de cette gamme.

Visitez :

POTRESTI VINCERE TU

La tua opinione ci aiuterà a migliorare la creazione futura di questa linea di prodotti.

Visita:

PUEDES GANAR

Tu opinión contribuirá al futuro de esta serie de productos.

Visita:

轻松获奖

您的反馈将有助于我们在今后改进本产品系列。

请访问:

[LEGO.com/productfeedback](https://www.lego.com/productfeedback)

You also have the chance to win a LEGO® set.

Terms and conditions apply.*

Außerdem hast du die Chance, ein LEGO® Set zu gewinnen.

Es gelten die Teilnahmebedingungen.*

Vous pourriez également gagner un ensemble LEGO®.

Des conditions s'appliquent.*

Hai anche la possibilità di vincere un set LEGO®.

Termini e condizioni sono applicabili.*

También tienes la oportunidad de ganar un set LEGO®.

Aplican términos y condiciones.*

您还有机会赢取乐高®套装。

条款和条件适用。*

*[LEGO.com/productfeedback-terms](https://www.lego.com/productfeedback-terms)

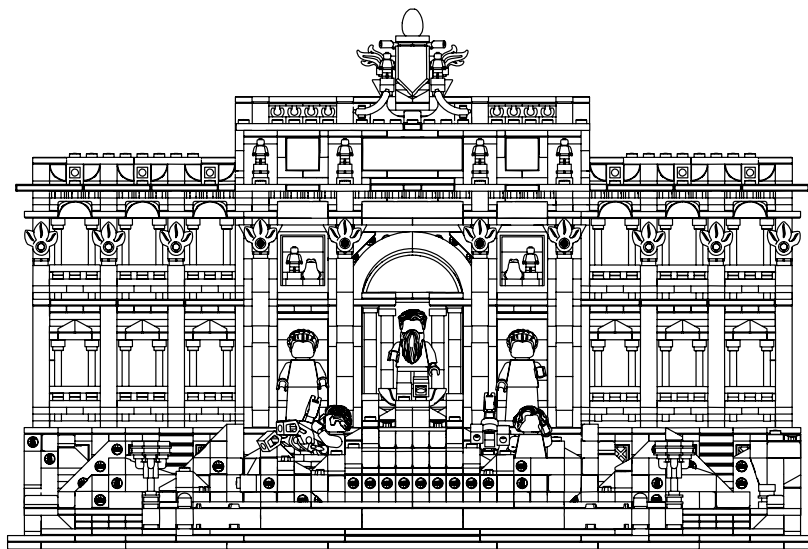

LEGO and the LEGO logo are trademarks of the LEGO Group. ©2025 The LEGO Group.
Adam Reed Tucker is the co-developer of the LEGO® Architecture product line.