



21062





LEGO.com/sustainable-packaging



FR  
**DONNEZ**  
OU  
**RECYCLEZ**



OU



OU



ASSOCIATION    MAGASIN    DÉCHÈTERIE

Adresses sur [quefairedemesdechets.fr](http://quefairedemesdechets.fr)



# BUILDER



Apple and the Apple logo are trademarks of Apple Inc., registered in the U.S. and other countries and regions. App Store is a service mark of Apple Inc. Google Play and the Google Play logo are trademarks of Google LLC. Tencent and the Tencent logo are trademarks of Tencent Inc.

Q [LEGO.com/devicecheck](https://www.lego.com/devicecheck)



Q LEGO® Builder



# CUANDO VAYAS A ROMA... / FONTANA DI TREVI

Desde que se terminara de construir en 1762, la Fontana di Trevi, en su forma actual, ha hecho brotar generosamente a través de los siglos un abundante venero de la rica historia y el espléndido patrimonio arquitectónico de Roma. El lugar donde se sitúa esta fuente ha jugado un papel determinante en el crecimiento y la prosperidad de la ciudad. Ya en el 19 a. C. (y hasta hoy a partir de entonces), su agua de manantial natural fluía por uno de los acueductos romanos más antiguos: el Acqua Vergine (Agua Virgen).

La fuente, una impresionante muestra del arte barroco, pone de manifiesto la inventiva romana con toda una galería de esculturas y simbólicos homenajes a deidades, leyendas y visionarios de la Roma clásica, y a la abundancia del mundo natural. Su nombre, que proviene de *tre vie* (tres caminos), destaca su localización estratégica en la intersección de tres calles utilizadas desde tiempos remotos por peregrinos y ciudadanos, y ahora por unos 10 millones de visitantes al año.

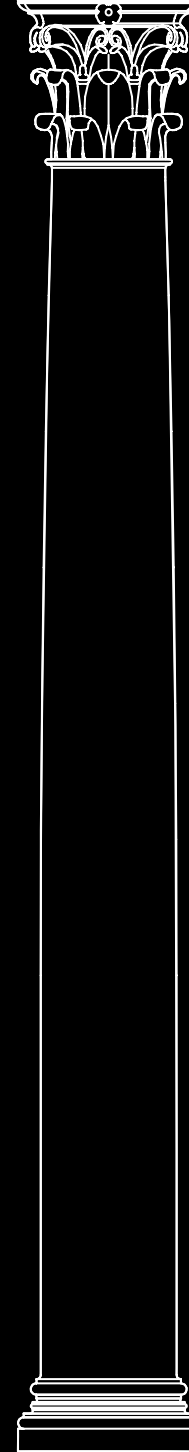

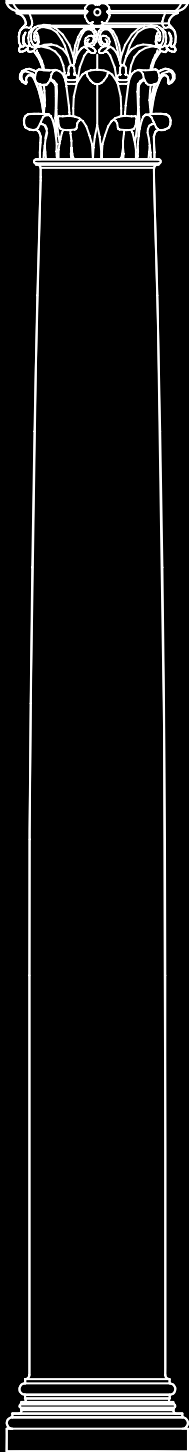

# IMPRESIONES DEL EQUIPO DE DISEÑO DE LEGO® ARCHITECTURE

Más que un espectáculo para la vista, como icono cultural, la Fontana di Trevi ha inspirado incontables obras de arte, literarias e incluso cinematográficas. Esta versión, heredera del popular set LEGO® Architecture Fontana de Trevi (21020) de 2014, vuelve a recrear el lugar, esta vez a mayor escala, como interpretación de la estructura real y con algunos detalles simplificados a la medida de la escena.

El objetivo principal fue capturar el ambiente barroco y la atmósfera de Roma en un día de verano, con los edificios de vibrantes colores que rodean la fuente y la cálida luz que reflejan sobre la *piazza*. Los relieves de la fachada proyectan sombras sobre sí mismos y sobre la cuenca, creando sutiles variaciones en los colores de las diferentes superficies. Mediante el uso de tonos de rosa, marrón, gris y blanco, queríamos captar la esencia de los intrincados matices del edificio, las estatuas, el agua y la cantería.



**Mary Wilson**  
Diseñadora de LEGO® Architecture



## PALAZZO POLI

El escudo de armas del papa Clemente XII, que mandó construir la Fontana di Trevi, aparece flanqueado por cuatro estatuas que representan los frutos y cultivos fertilizados por el agua.



## OCÉANO (NEPTUNO)

El dios de los mares conduce el carro con forma de concha tirado por míticos hippocampi (caballos de mar). Se trata de un símbolo de la maestría y las habilidades avanzadas de los ingenieros romanos en el diseño y la construcción de acueductos para gestionar el suministro de agua.



## AGRIPA

El general y arquitecto romano Marco Vipsanio Agripa (63-12 a. C.) figura en actitud de aprobar los planos para la construcción del acueducto original.



## LA VIRGEN

Un homenaje a una niña que, según la leyenda, señaló el manantial a los soldados romanos hace milenios.



## SALUD

La diosa de la salud sostiene una copa de la que bebe una serpiente, alegoría de la pureza y el poder sanador del agua.



## ABUNDANCIA

La diosa de la abundancia vierte agua de su gran urna como alegoría del caudal de agua que fluye de los acueductos y la fertilidad que aporta a la tierra.



## TRITONES

Criaturas marinas míticas mitad hombre, mitad pez. Uno trata de retener a un hipocampo inquieto (la naturaleza turbulenta del mar) y el otro guía a un hipocampo tranquilo (las aguas bajo el control romano).



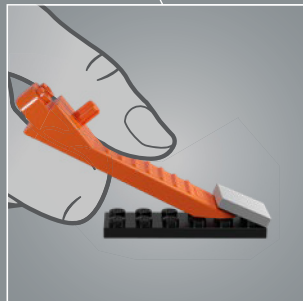
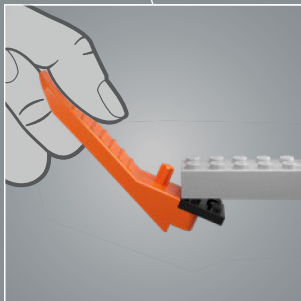
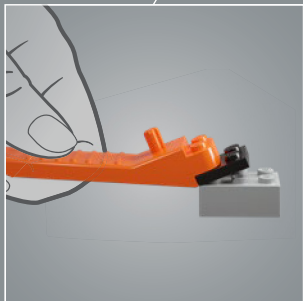
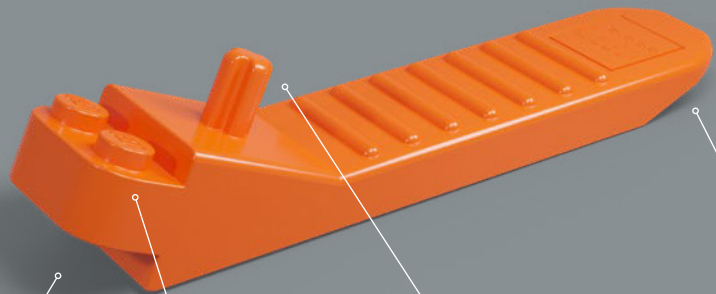



Diseñada por Nicola Salvi, la construcción de la Fontana di Trevi duró más de 30 años; fue finalizada por el escultor Pietro Bracci, amigo del diseñador, en 1762 (11 años después de la muerte de Salvi).

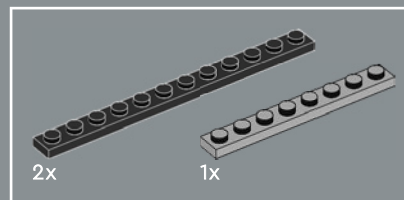

1

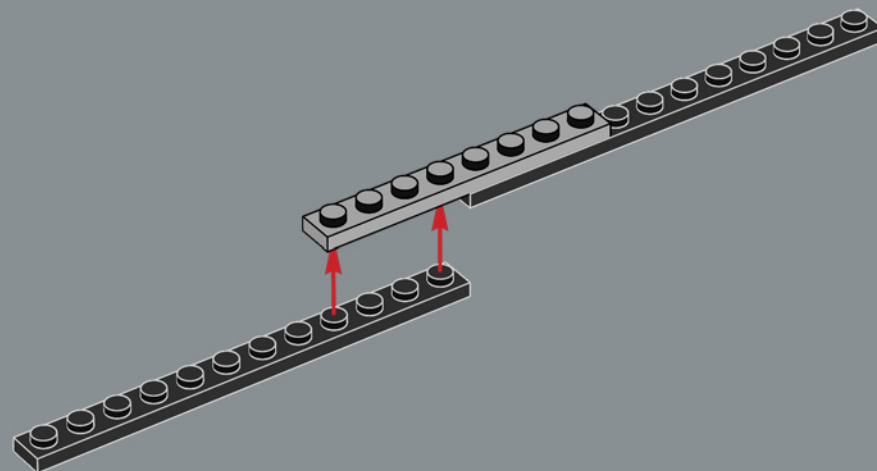

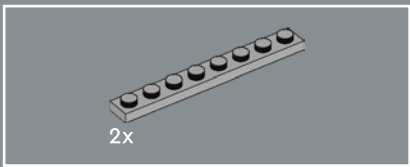

2

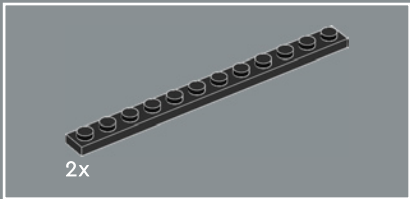
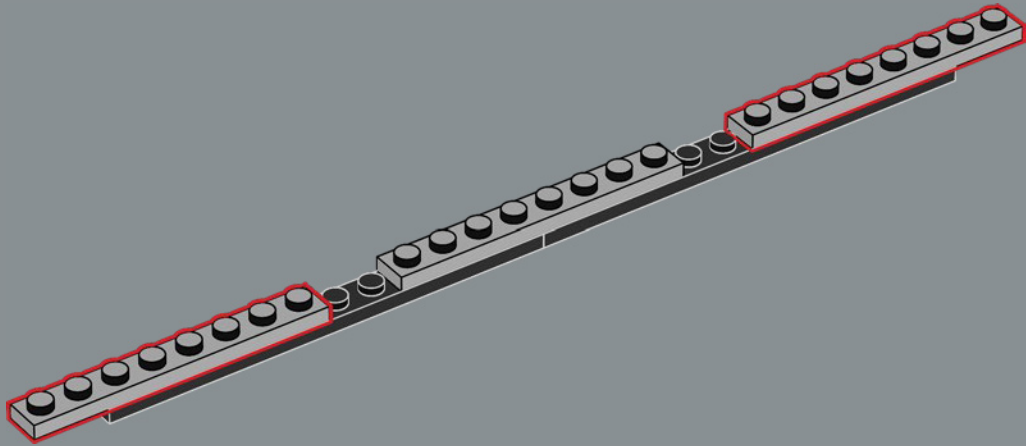

3

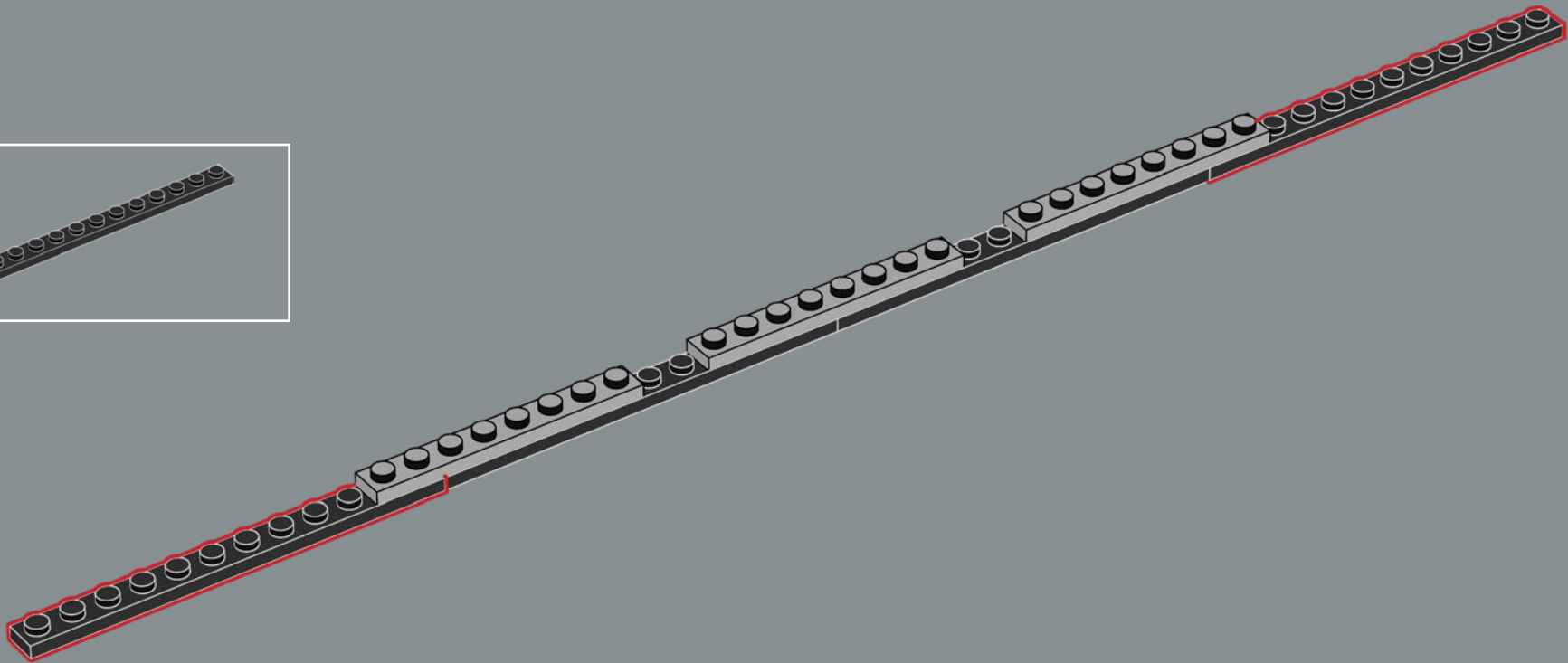

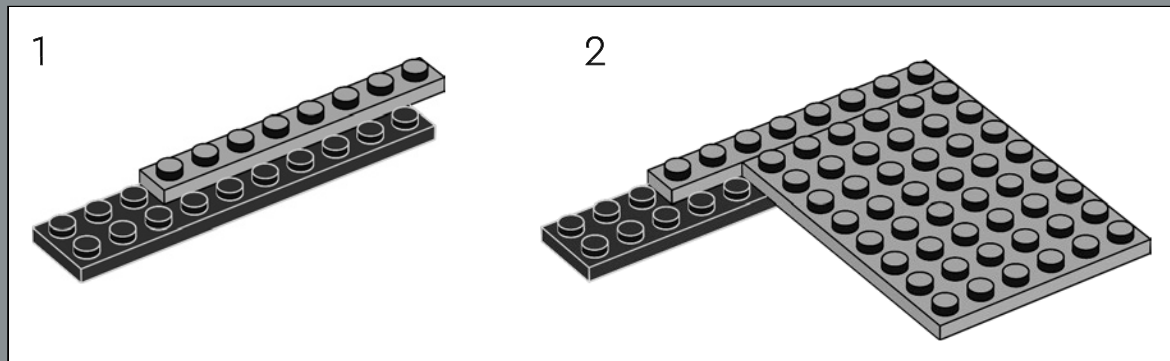
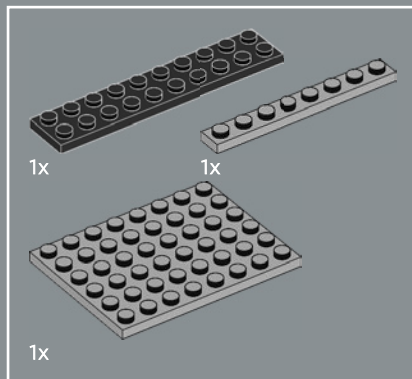

4

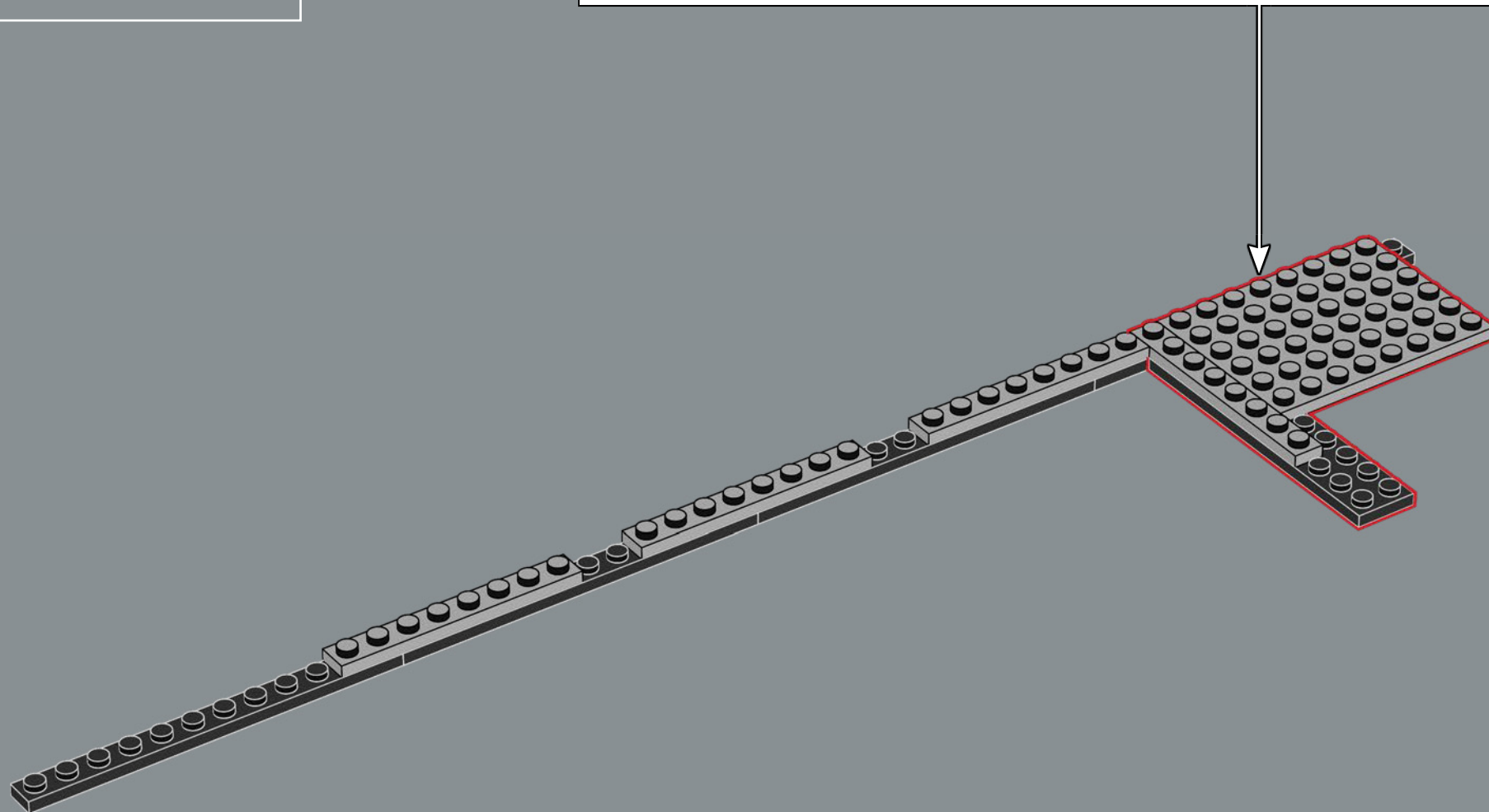

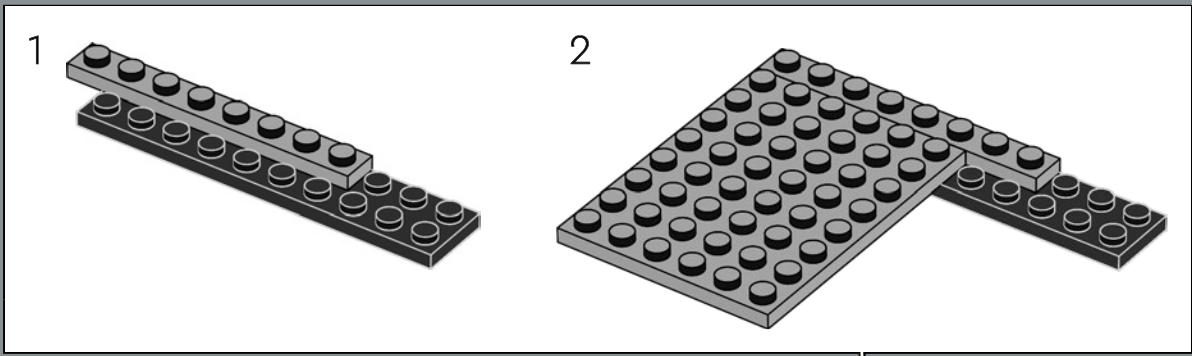
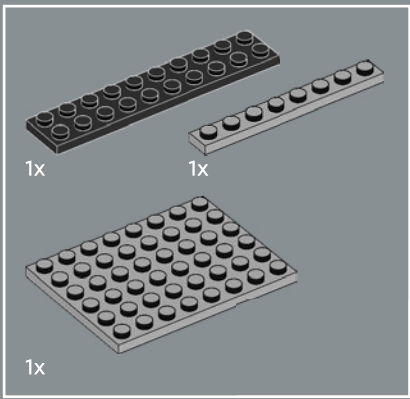

5

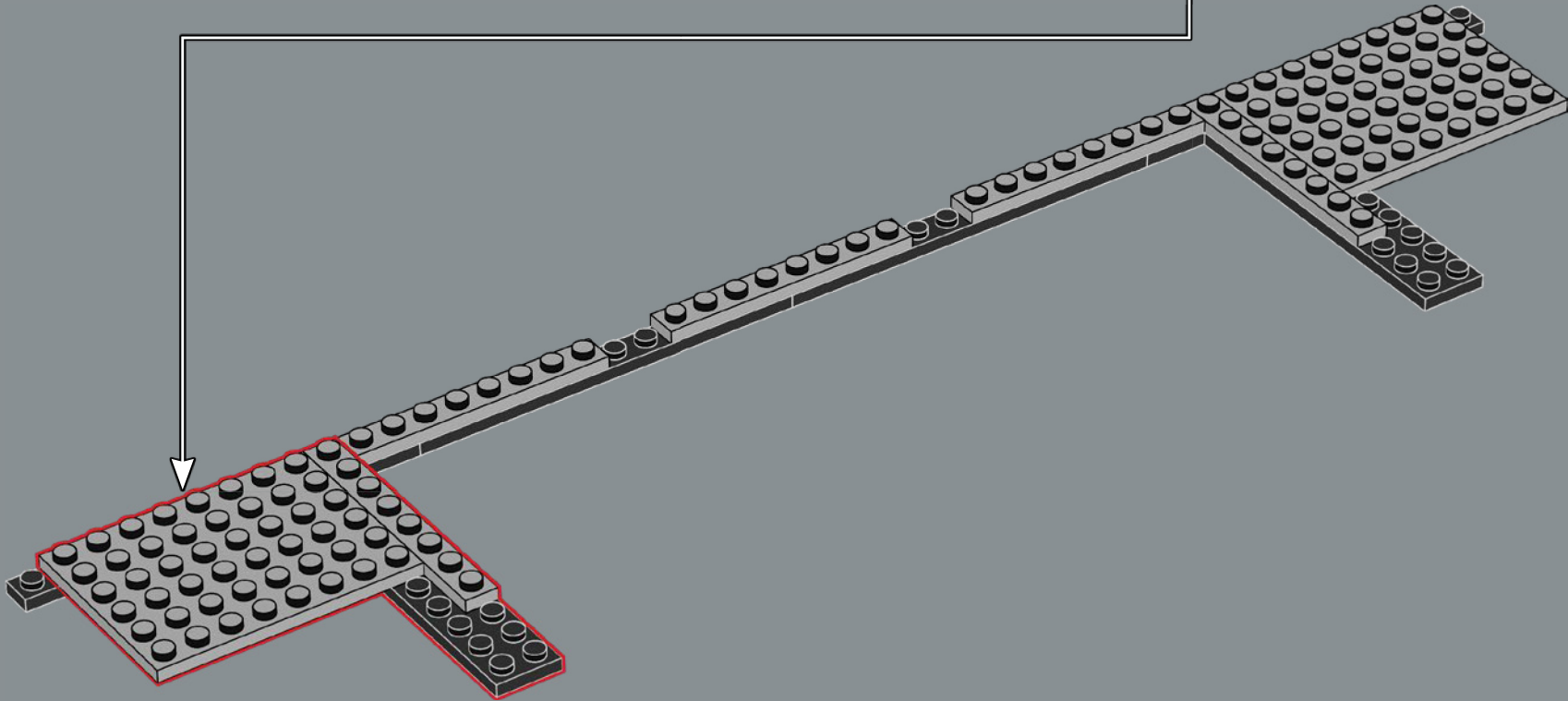

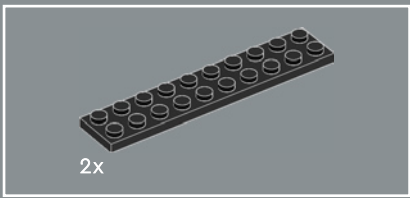

6

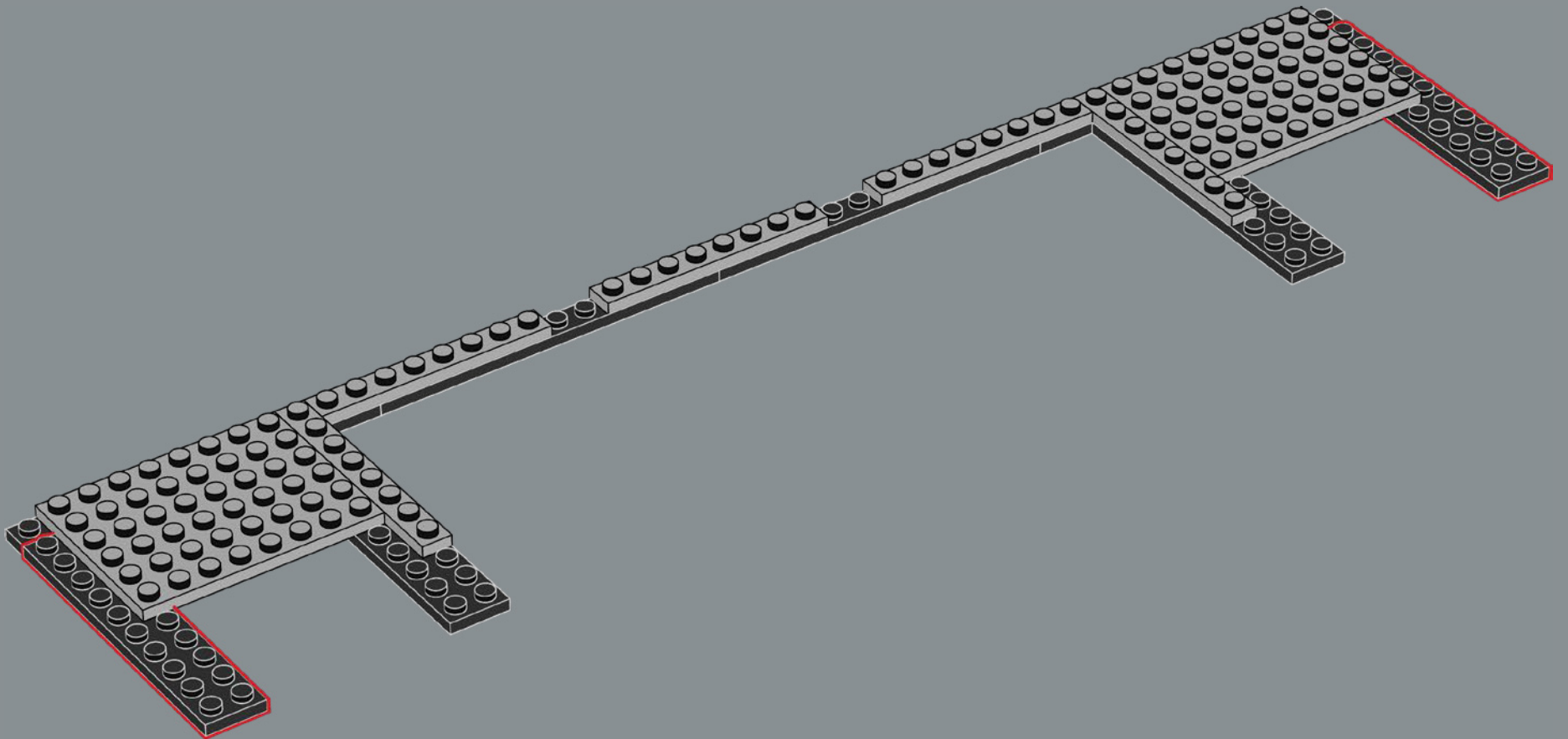

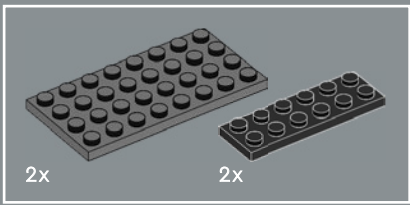

7

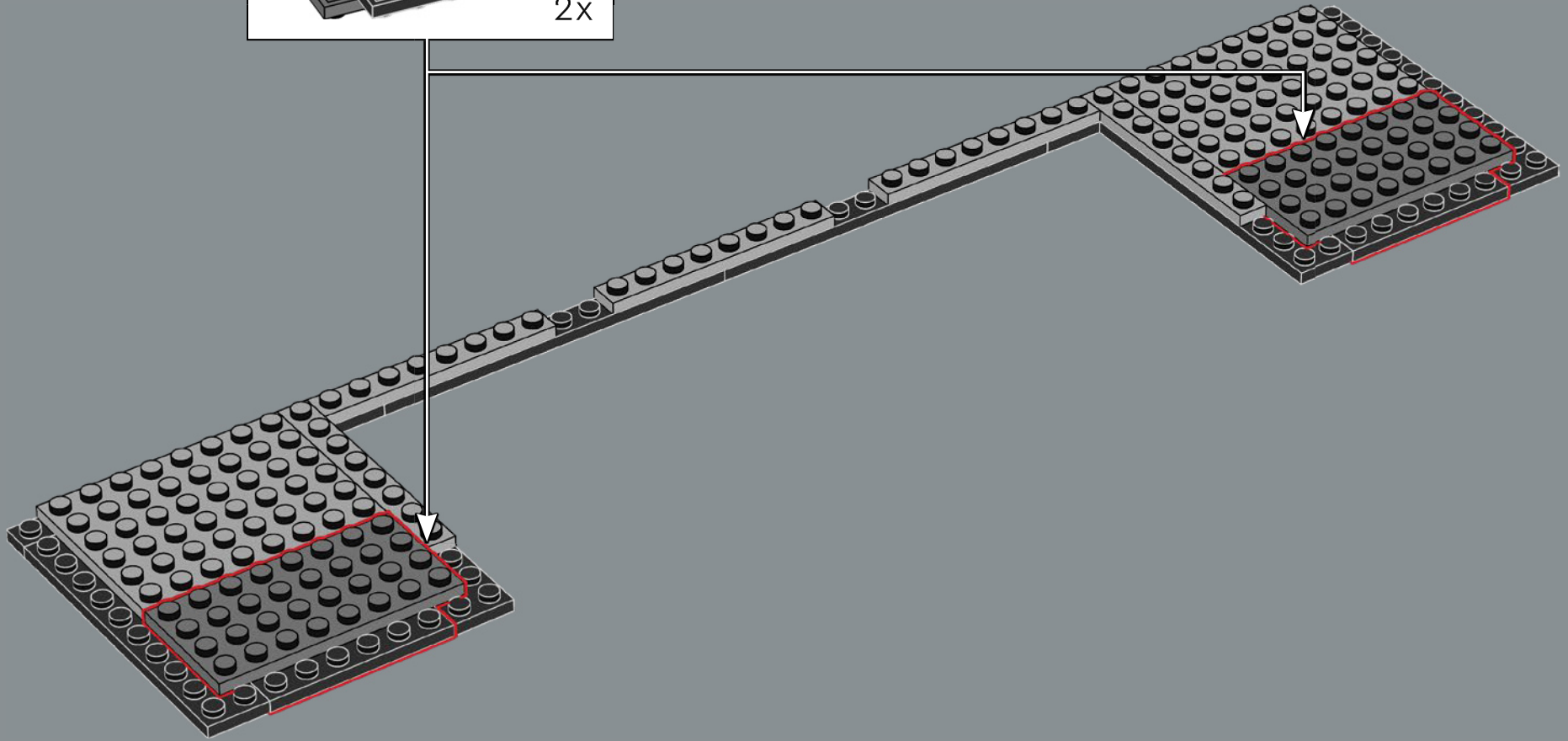
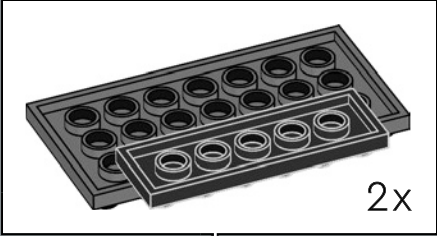



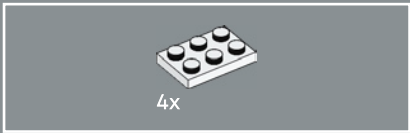

8

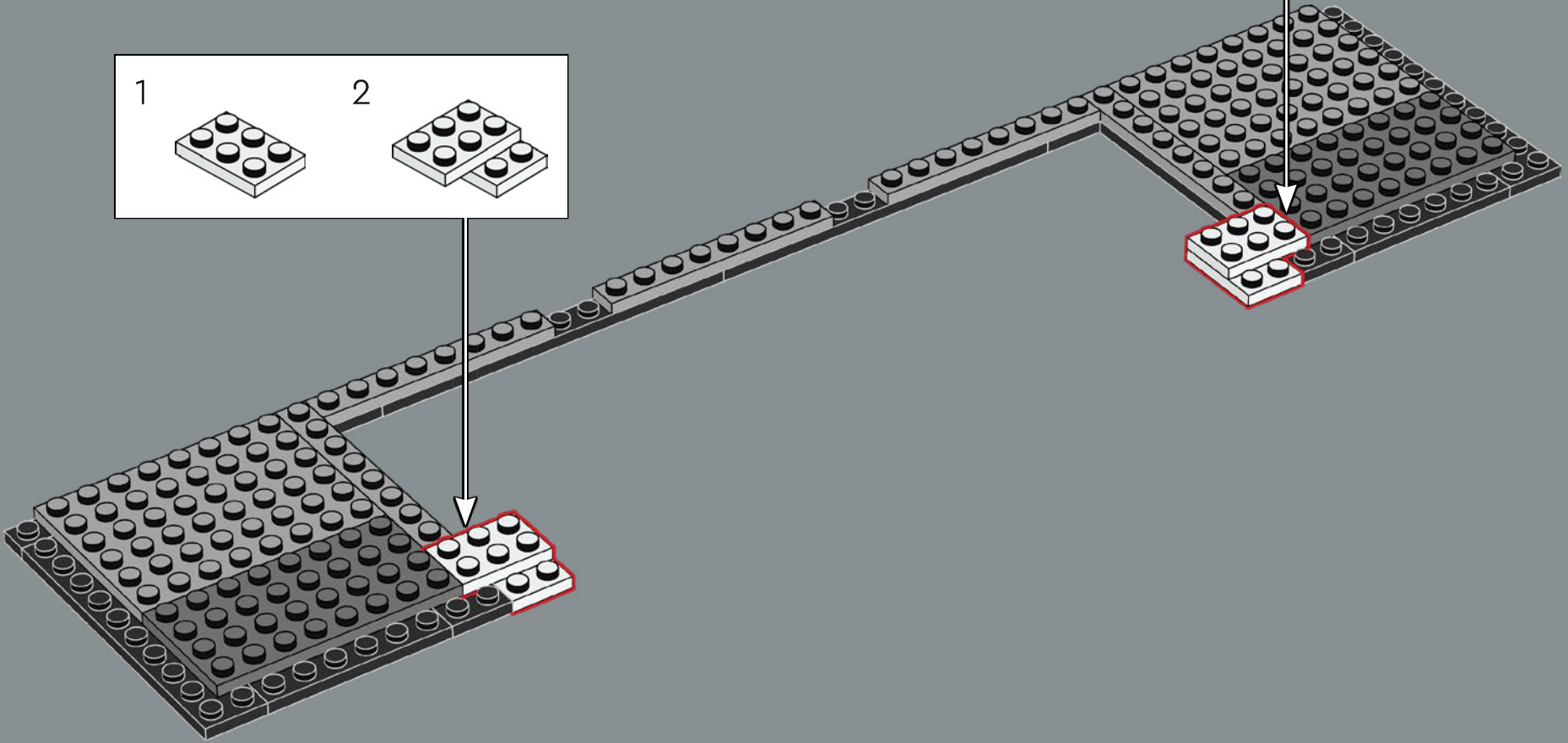
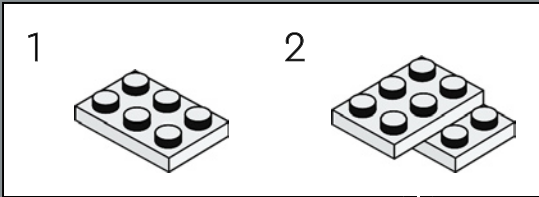
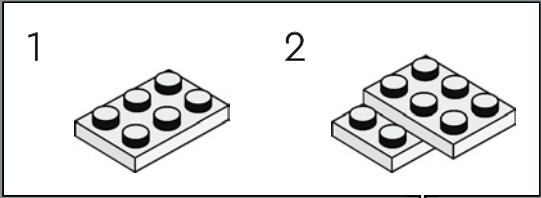

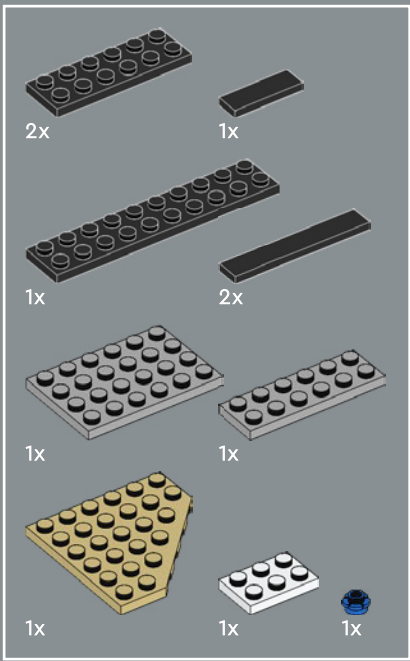

9

1

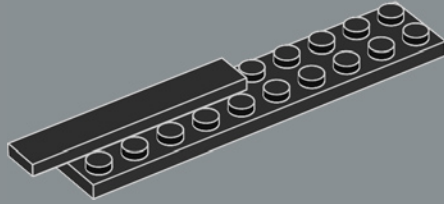

2

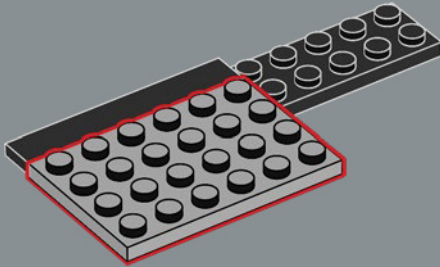

3

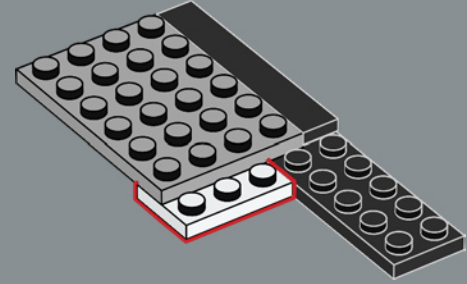

4

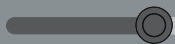
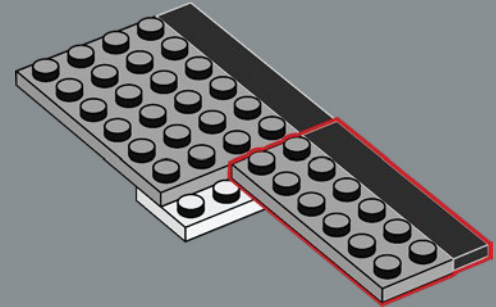

5

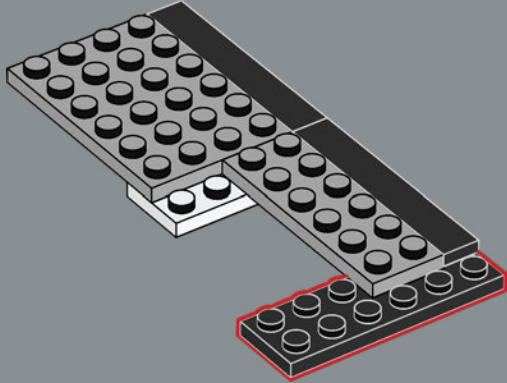

6

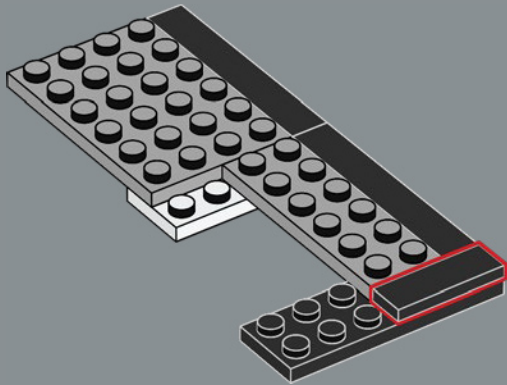

7

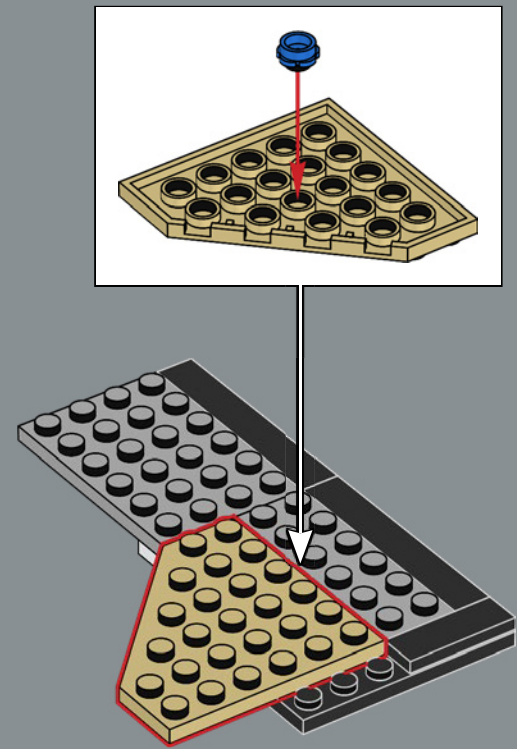

8

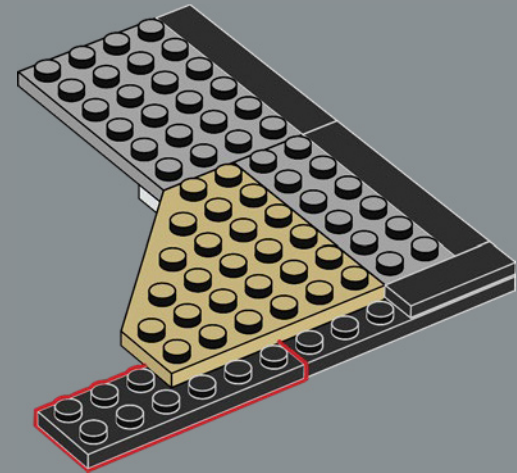

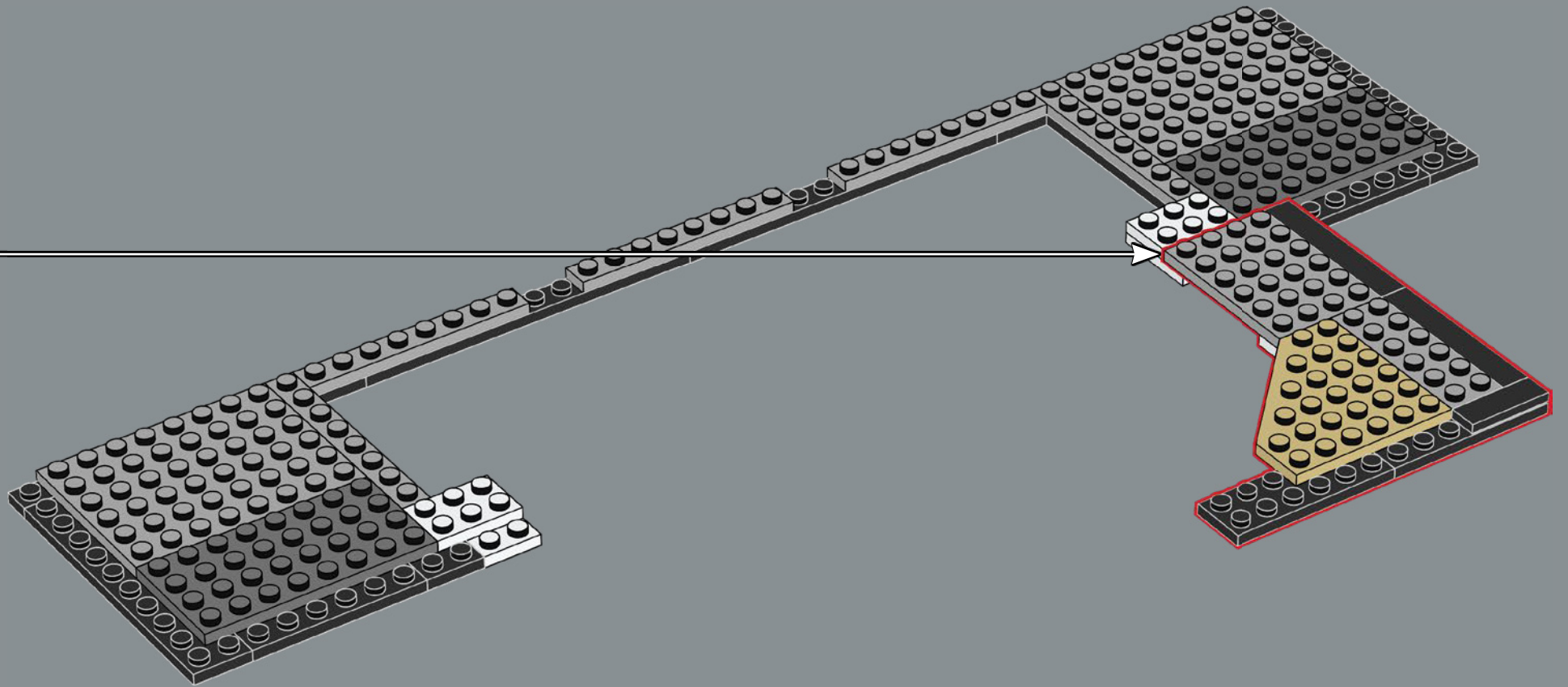

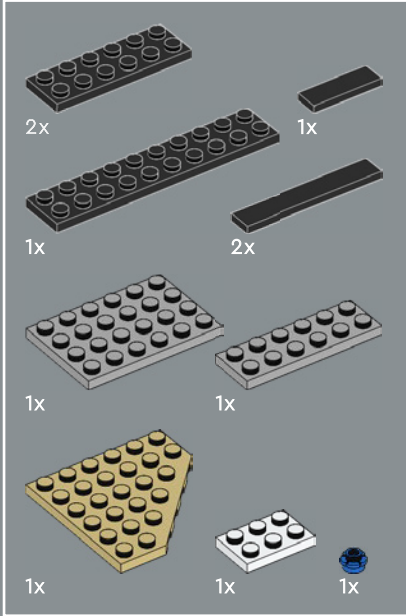
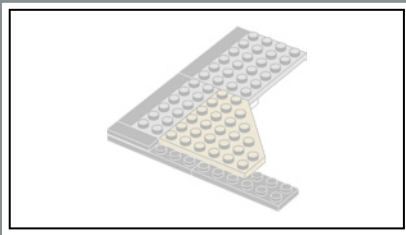

10

1

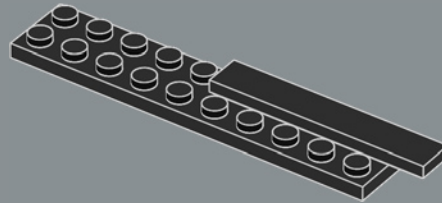

2

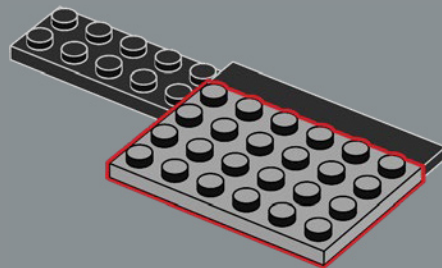

3

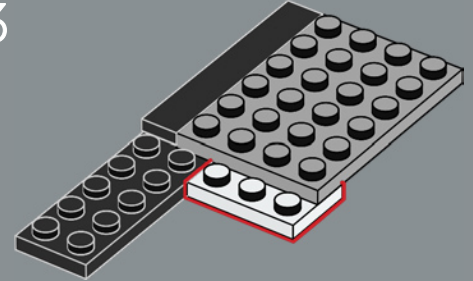

4

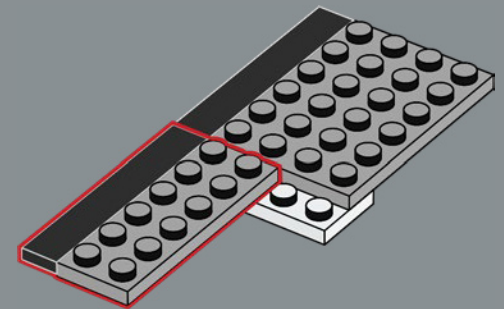

5

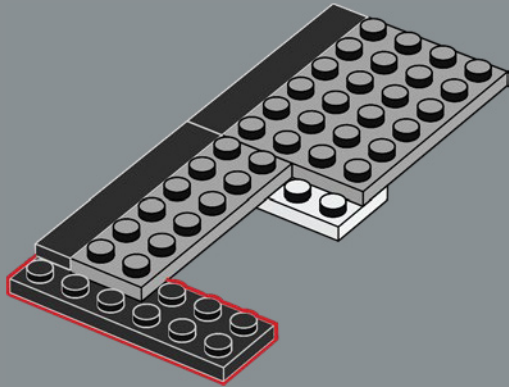

6

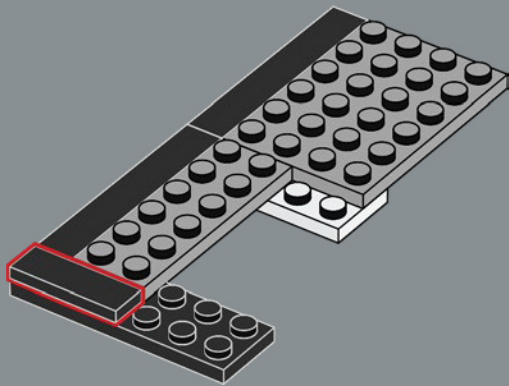

7

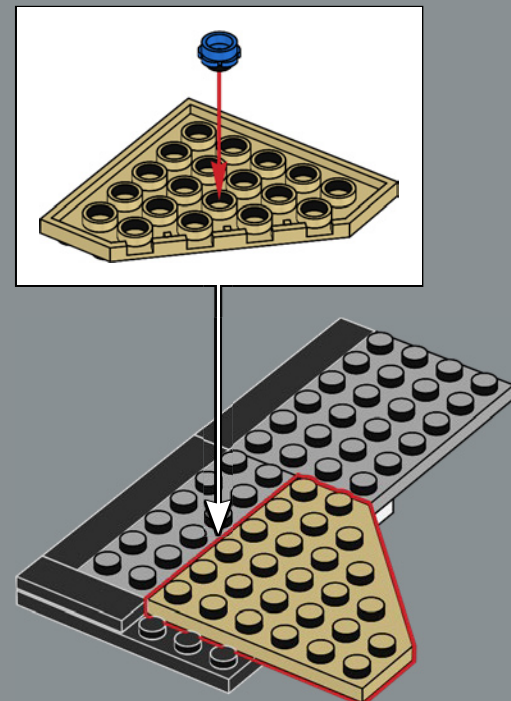

8

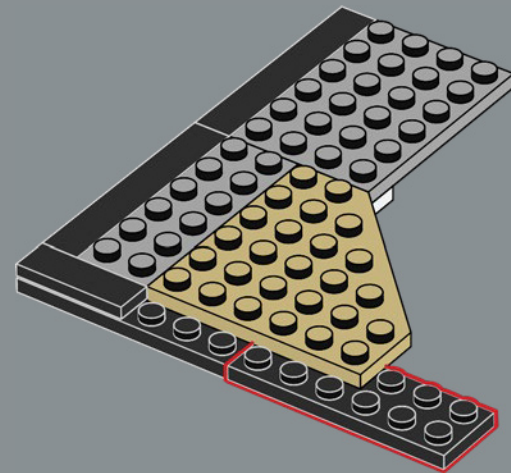

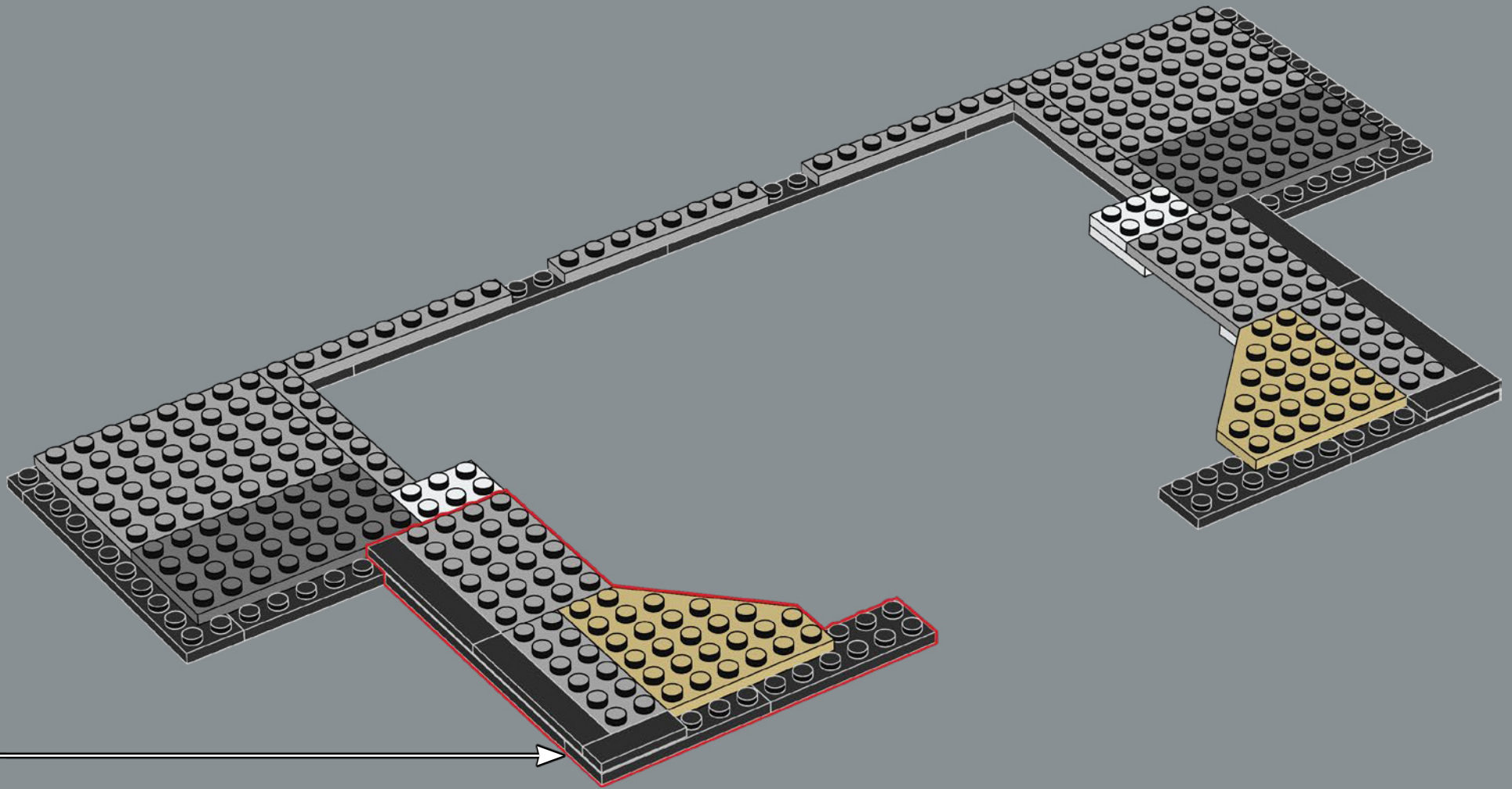

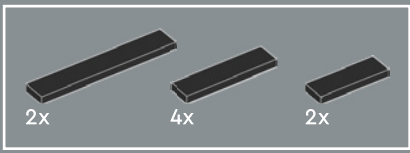

11

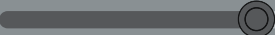
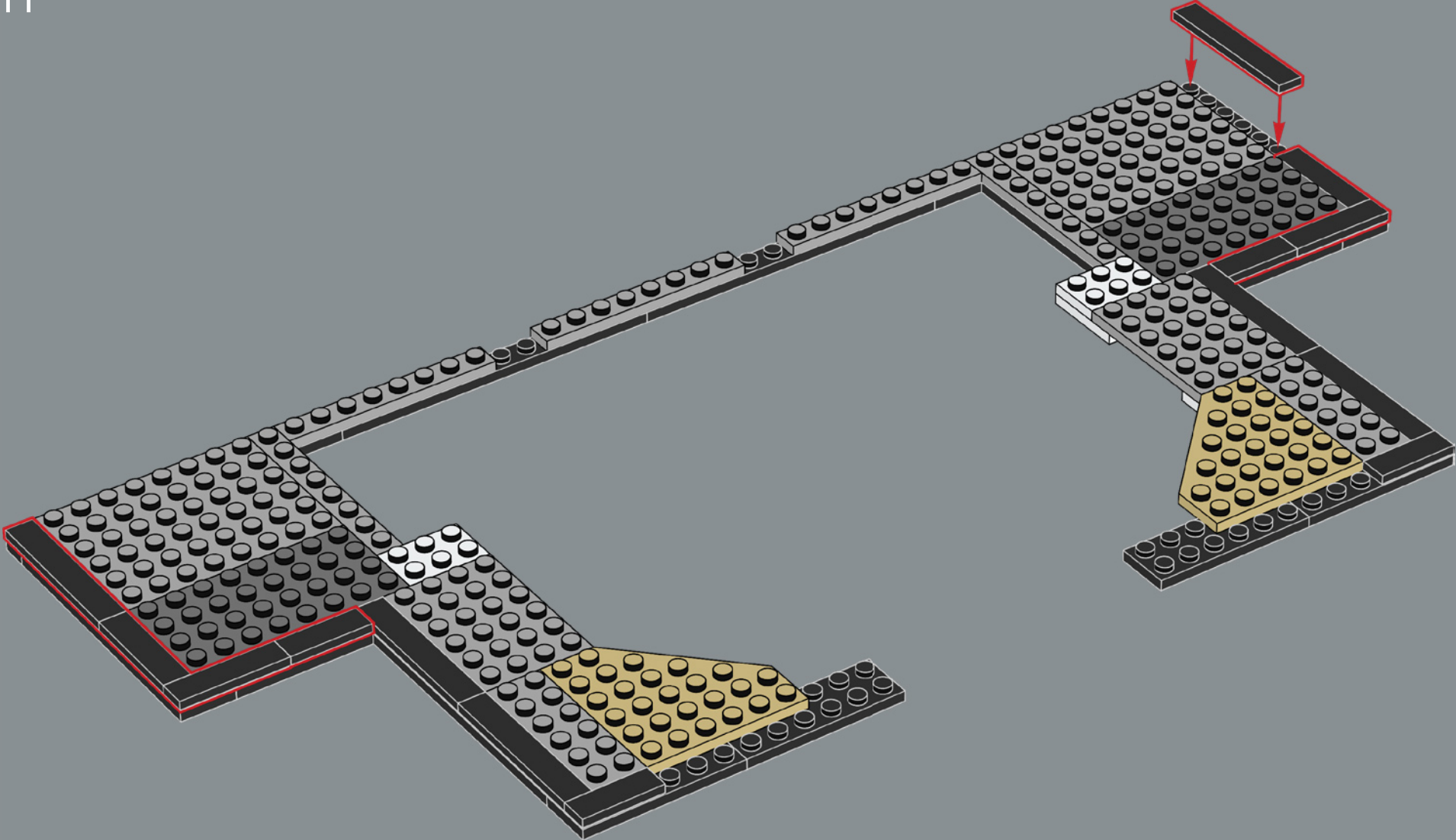



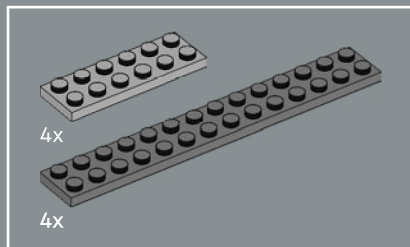

12

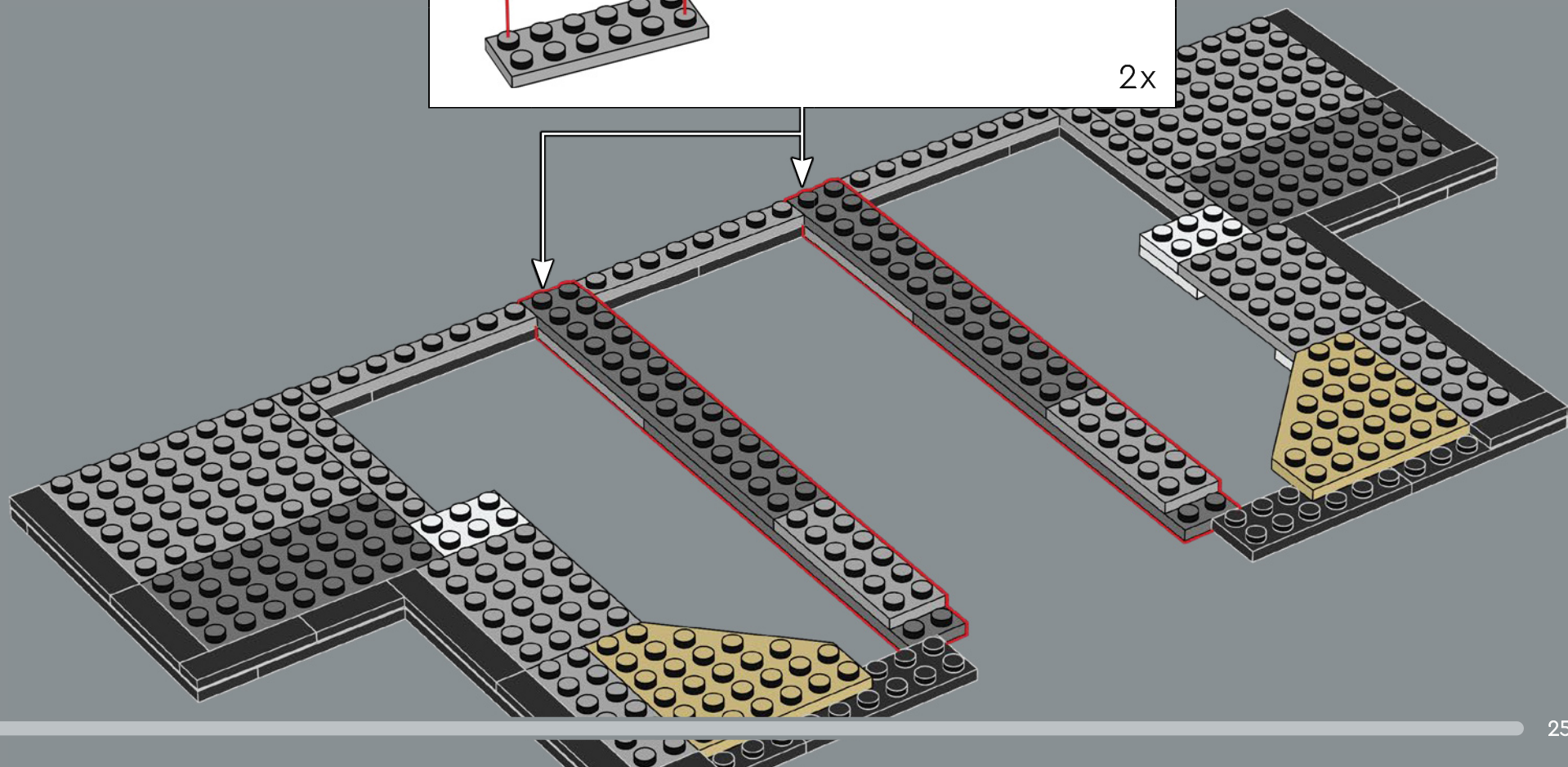
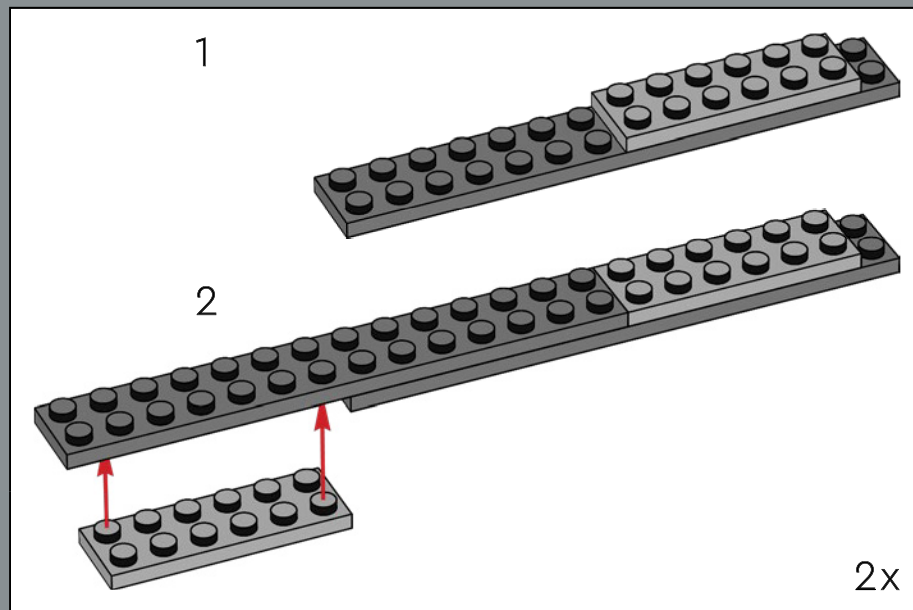

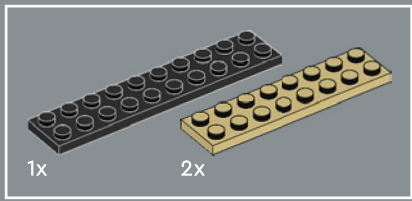

13

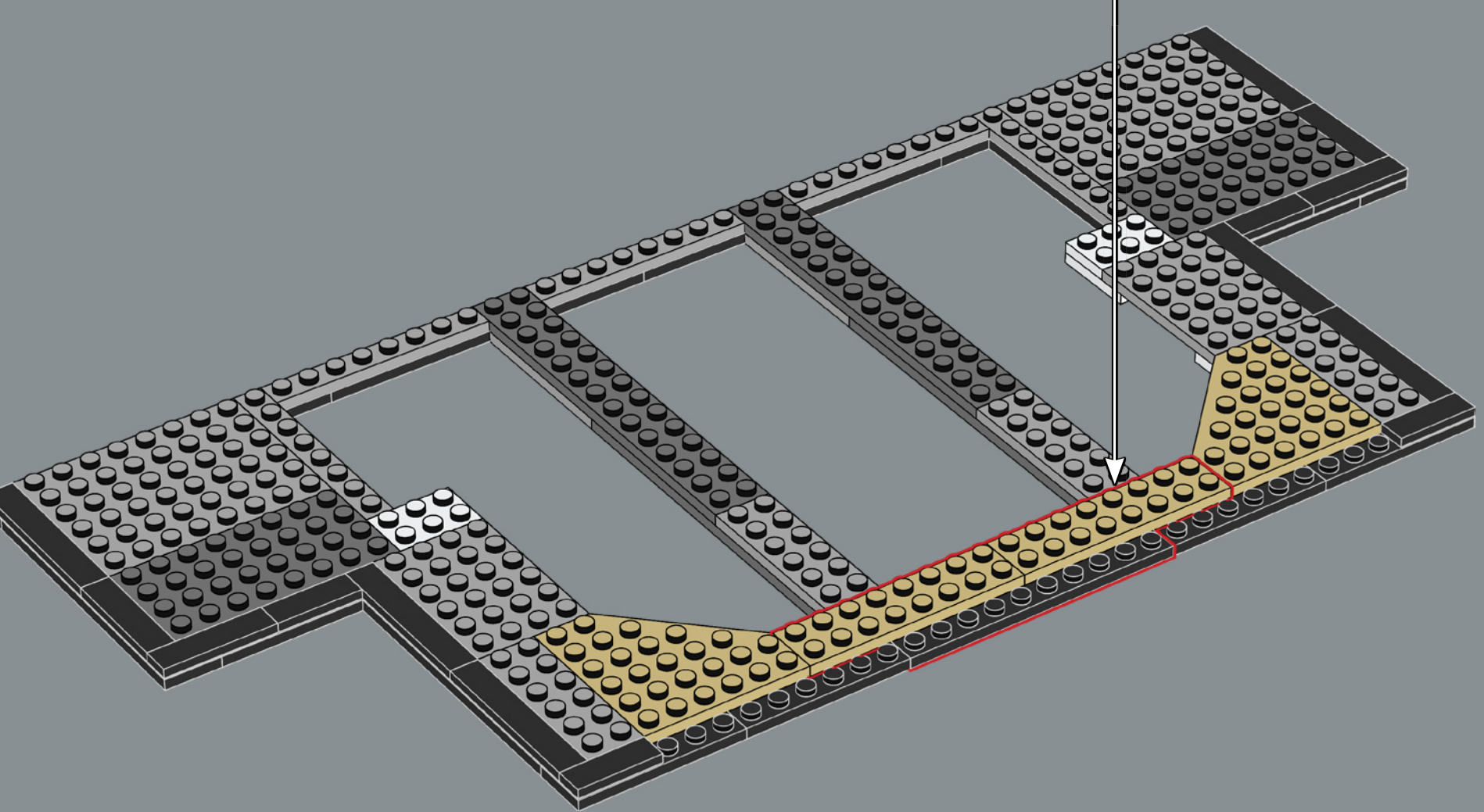
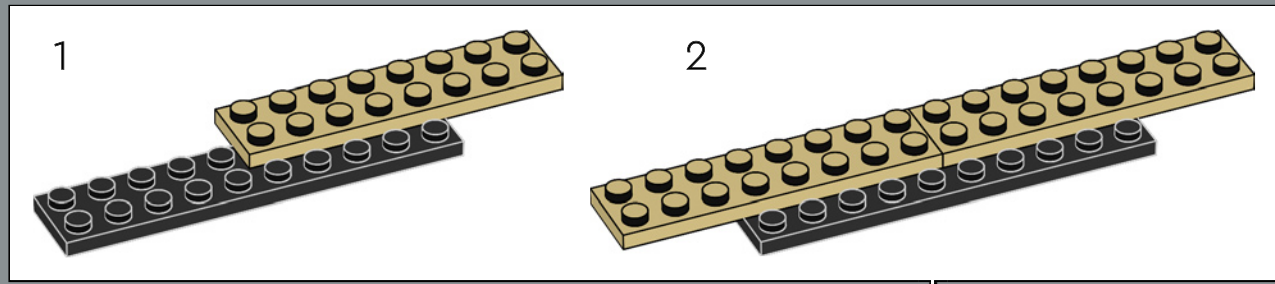

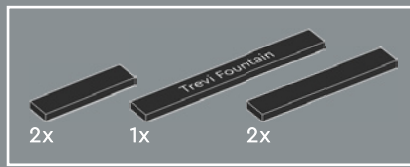

A lo largo de los siglos, los “tres caminos” que conducían a la Fontana di Trevi e inspiraron su nombre aumentaron a los cinco que ahora desembocan en la famosa *piazza*.

14

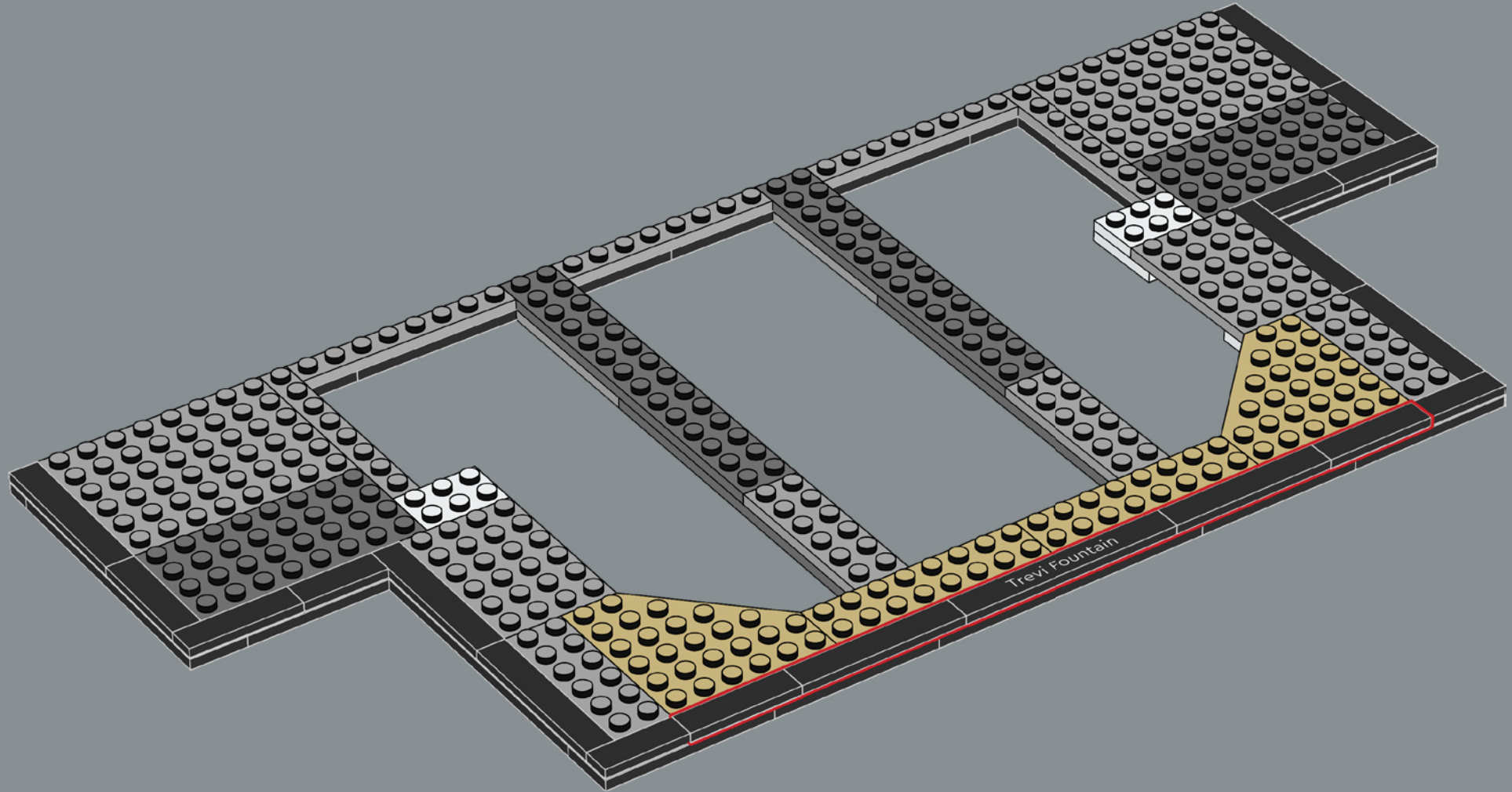

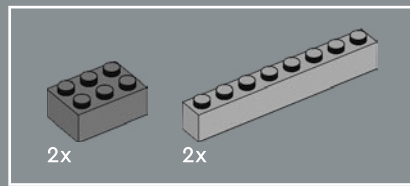

15

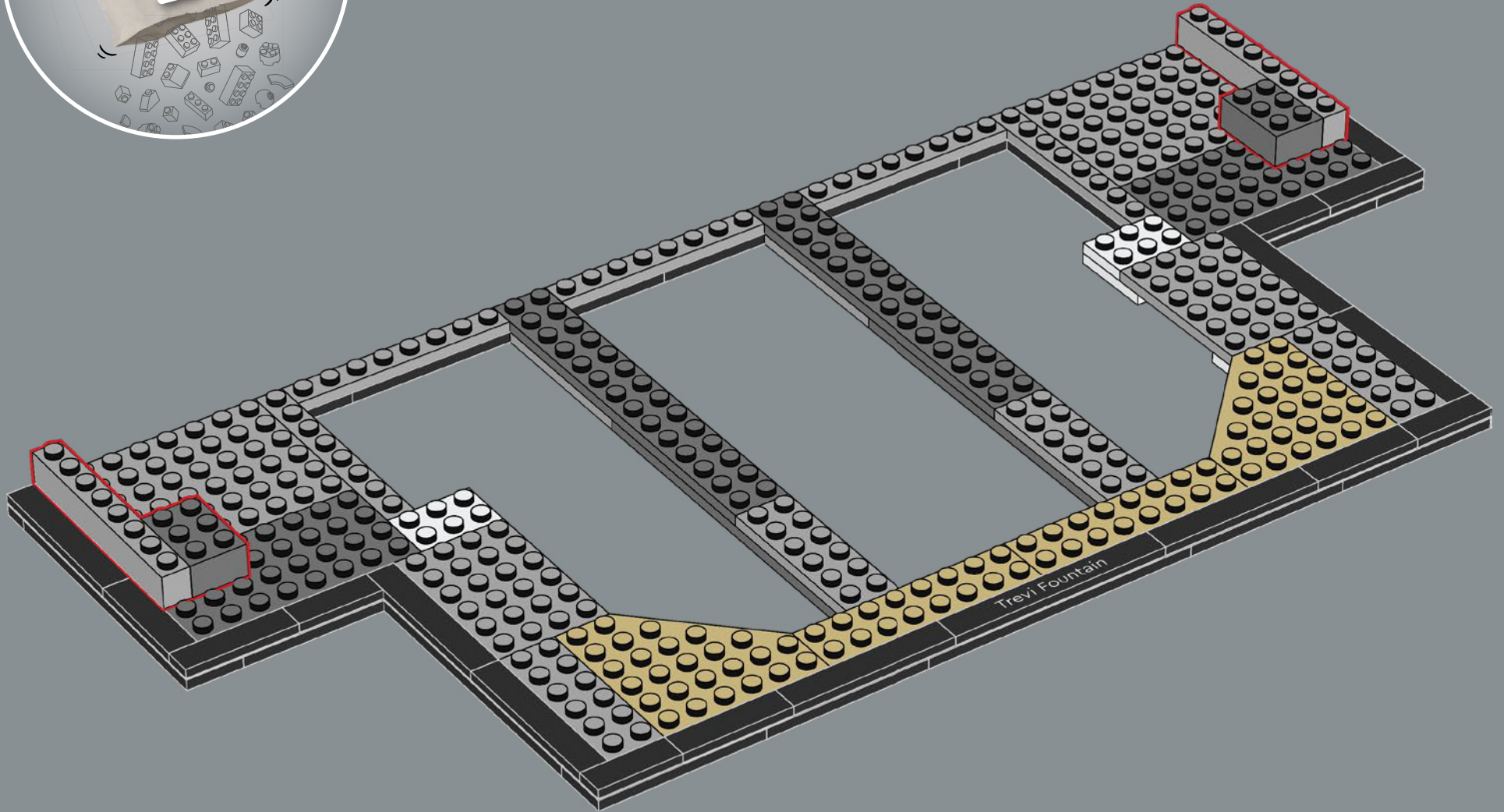

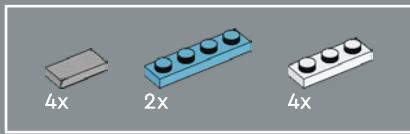

16

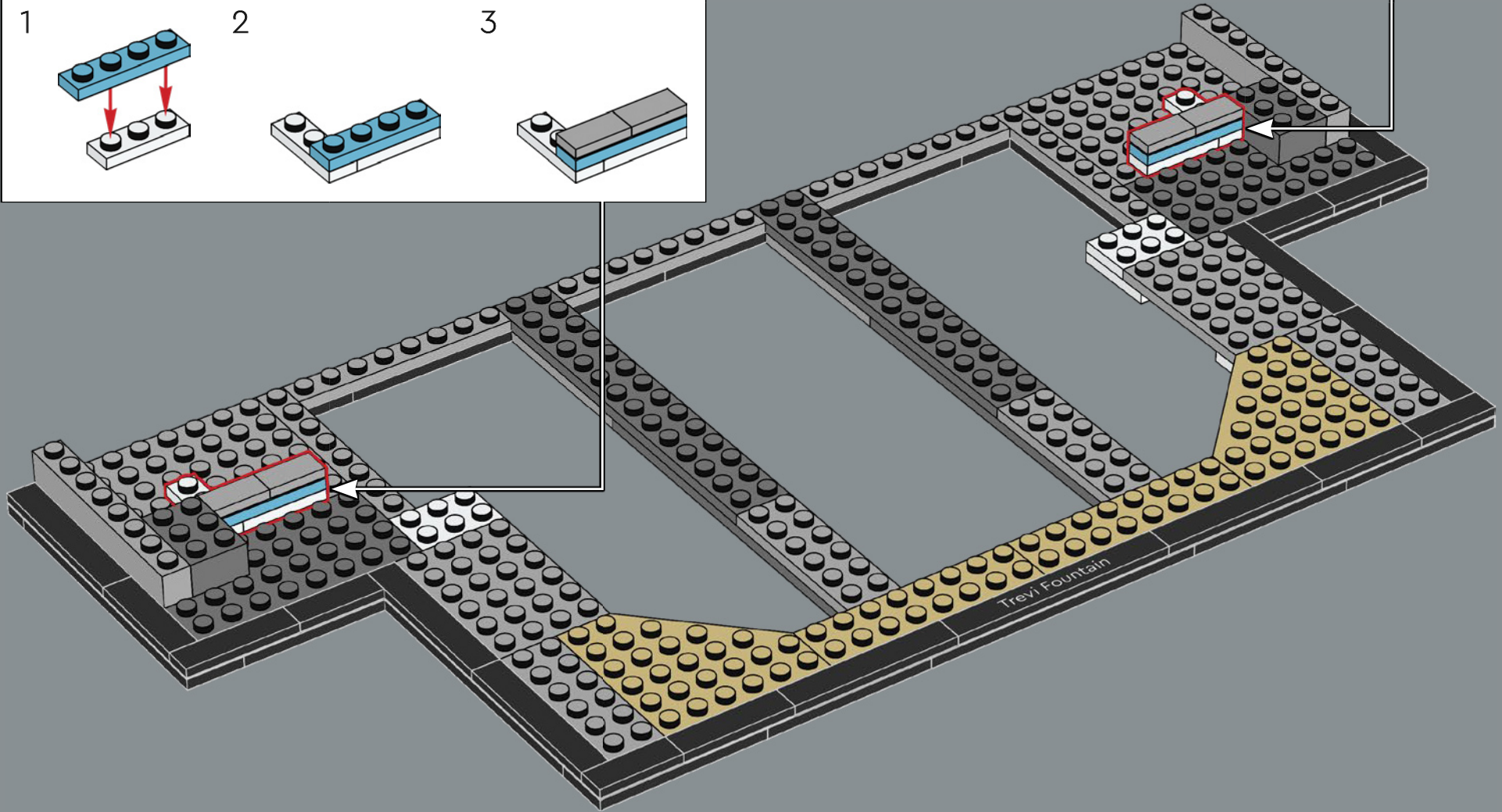
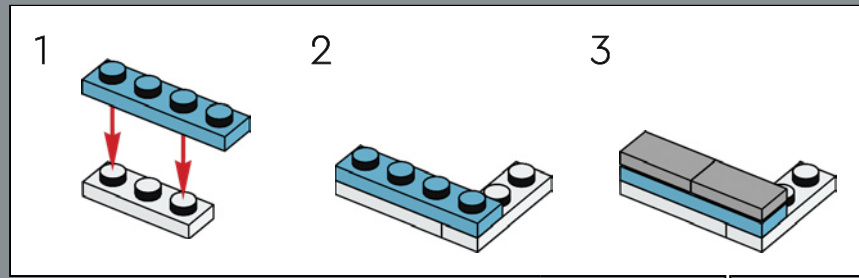
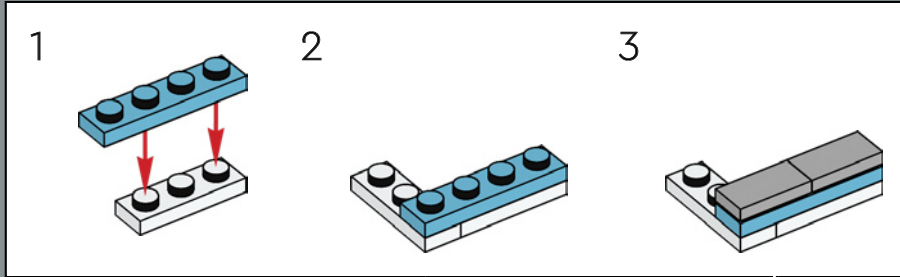

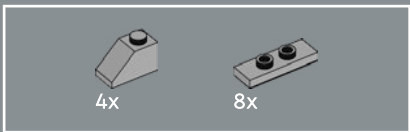

17

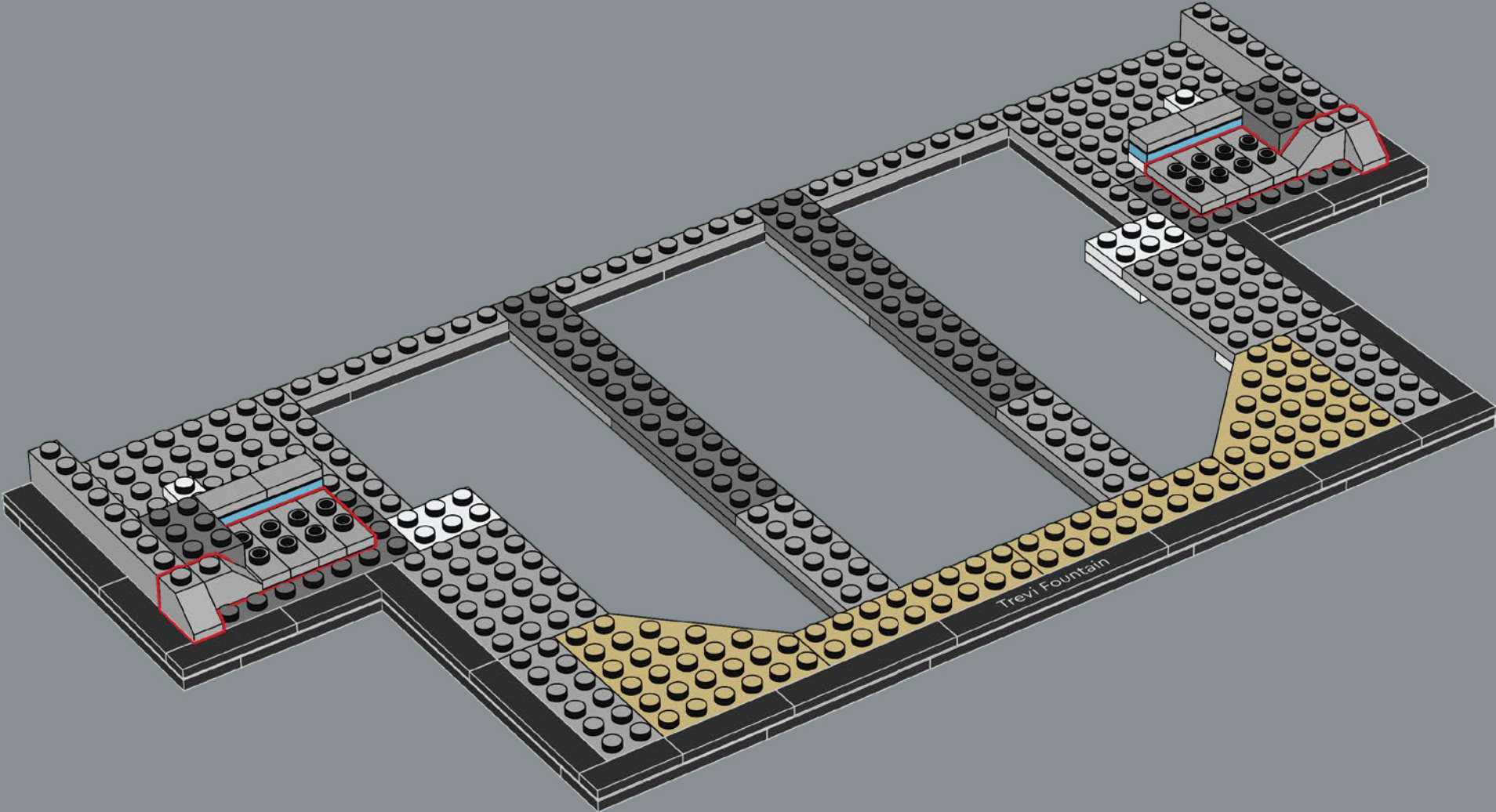

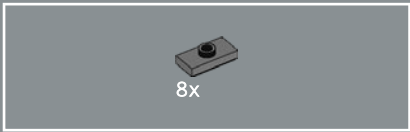

18

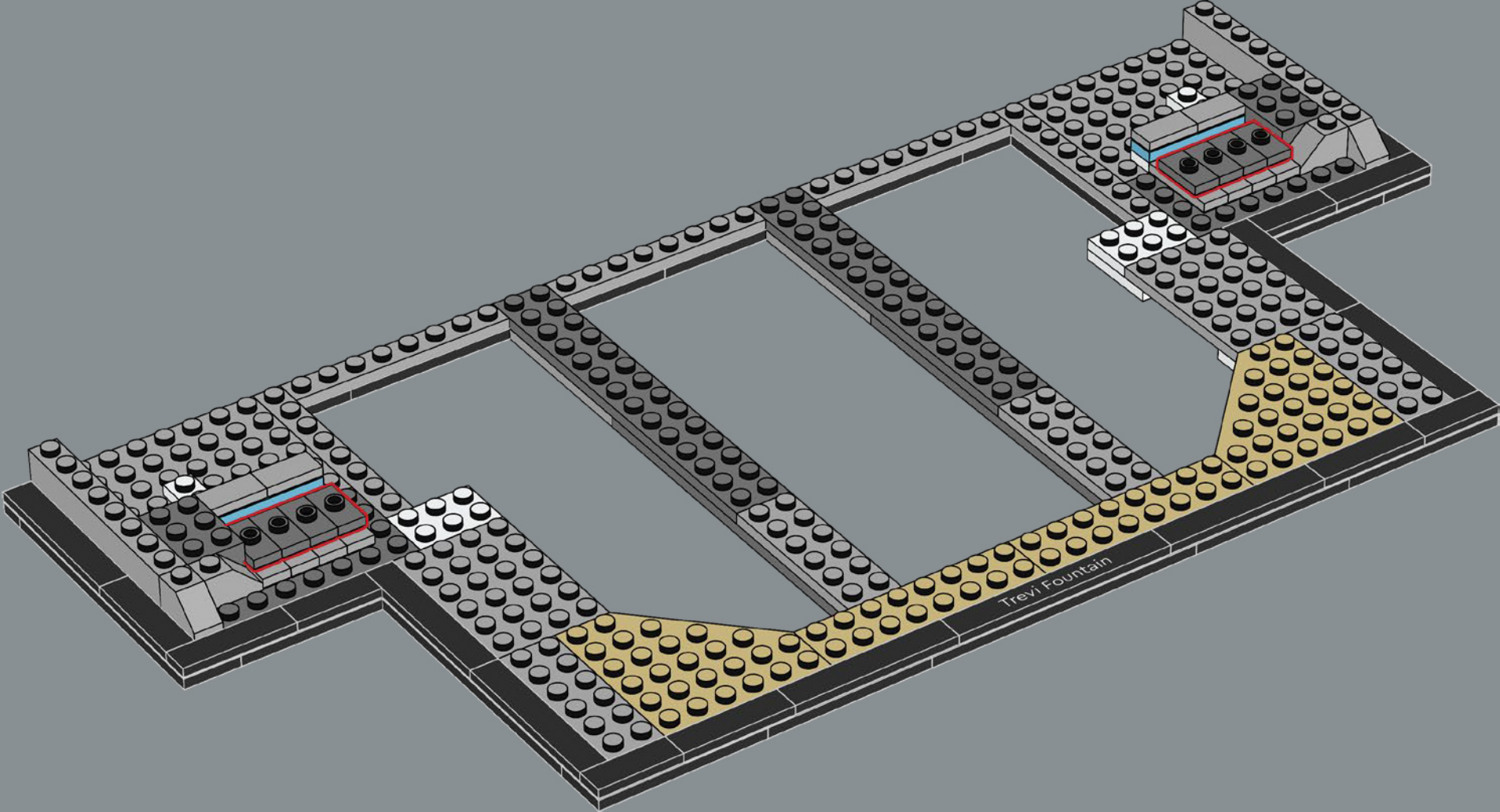



8x

19

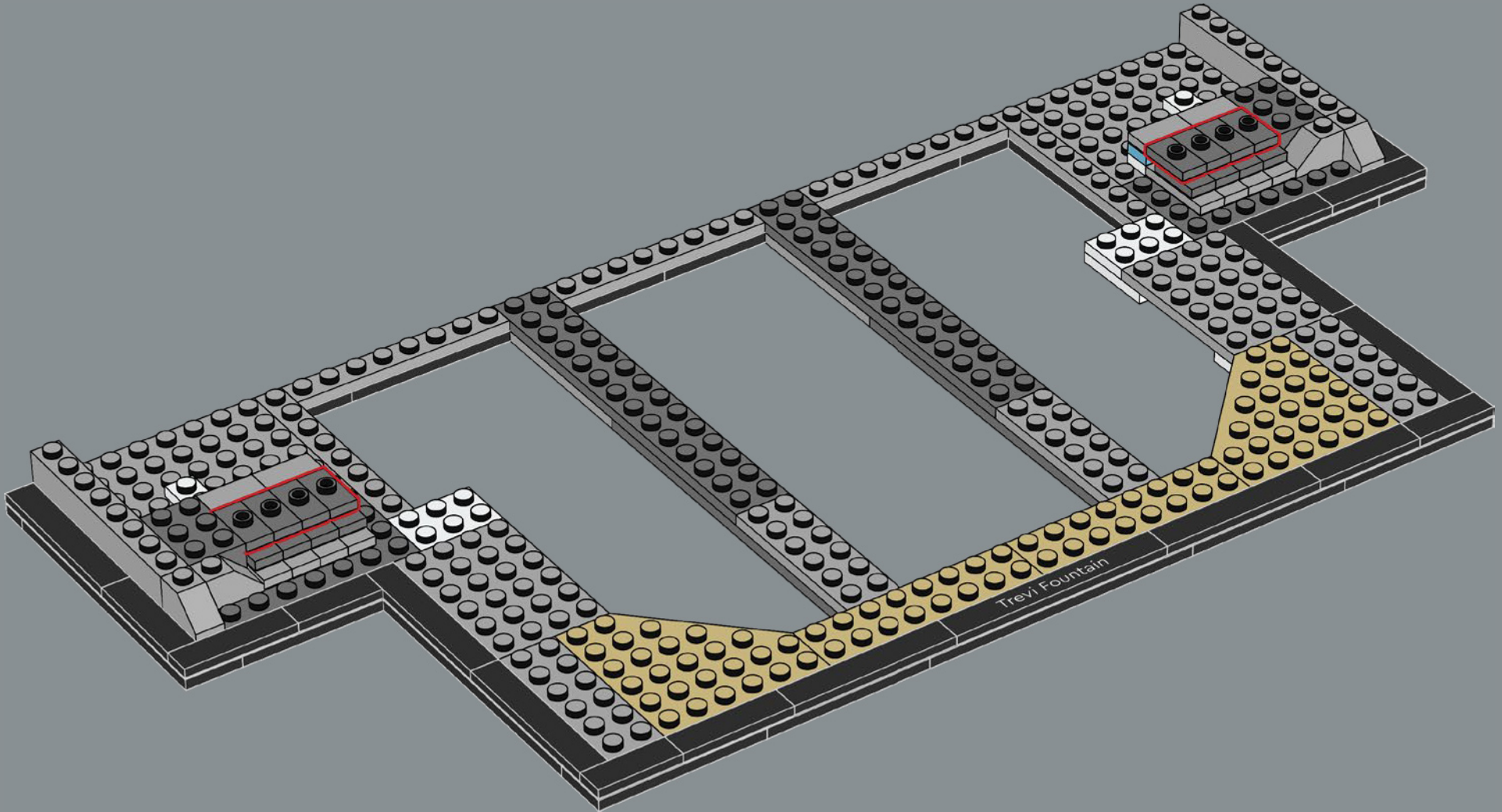



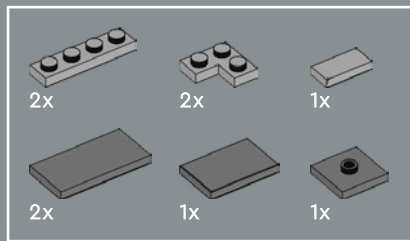

El intenso tránsito peatonal hacia el monumento contribuye también a la decoloración del pavimento, los peldaños y la cantería inferior.

20

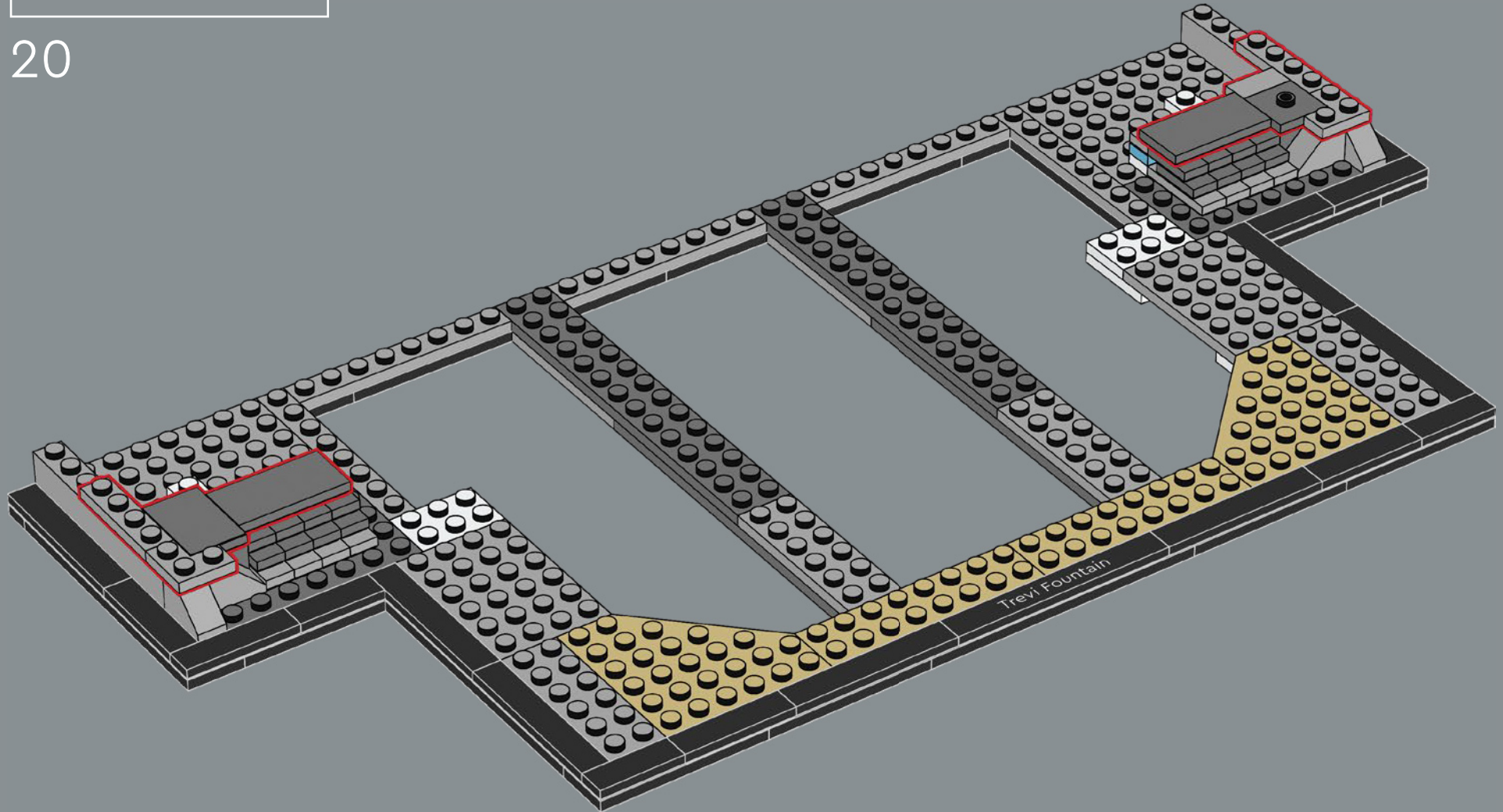

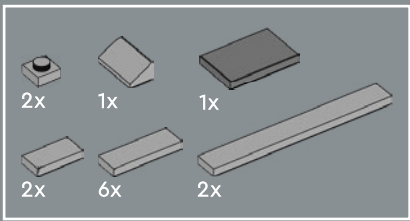

21

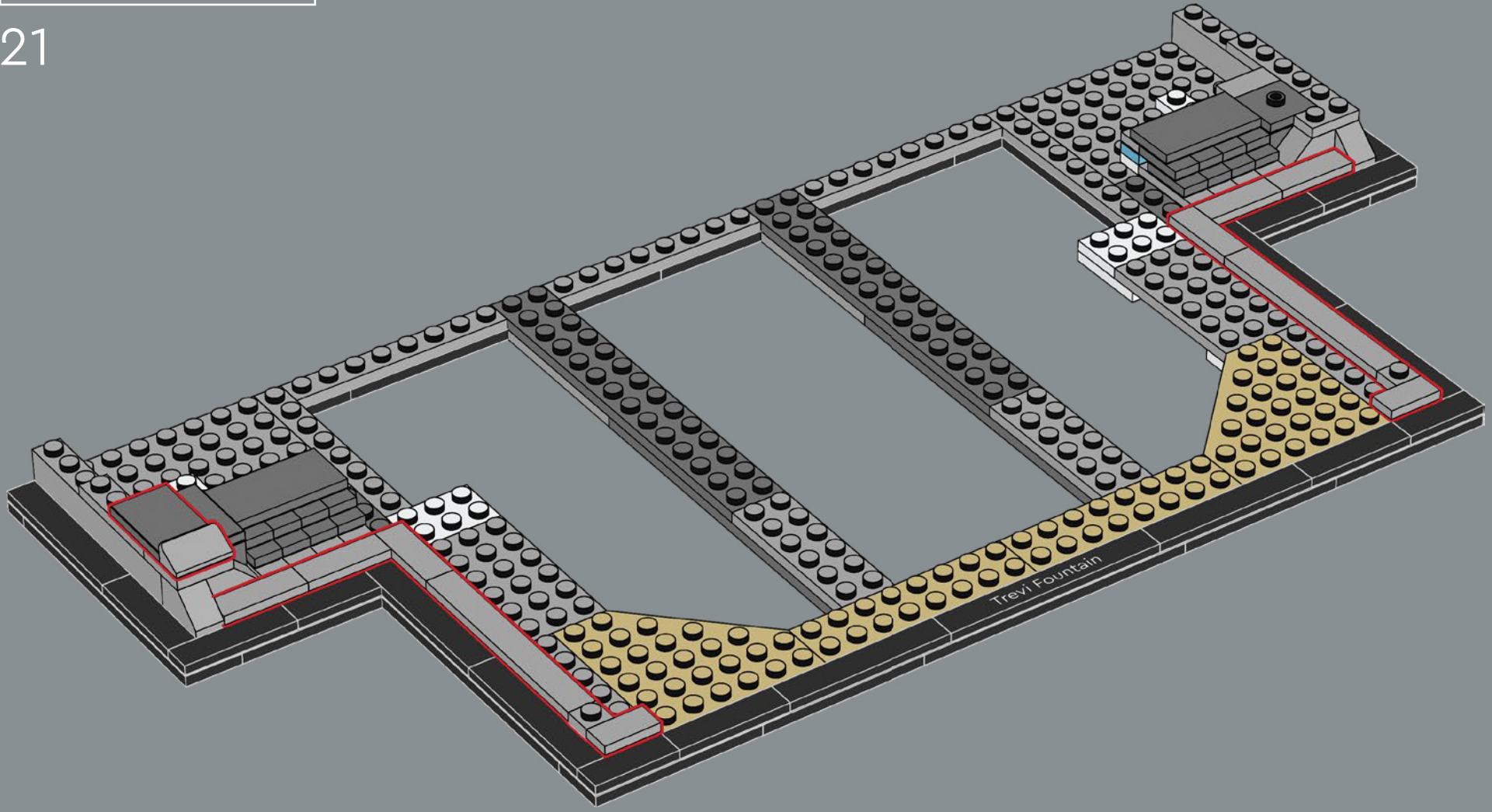

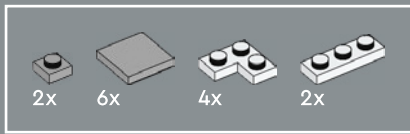

22

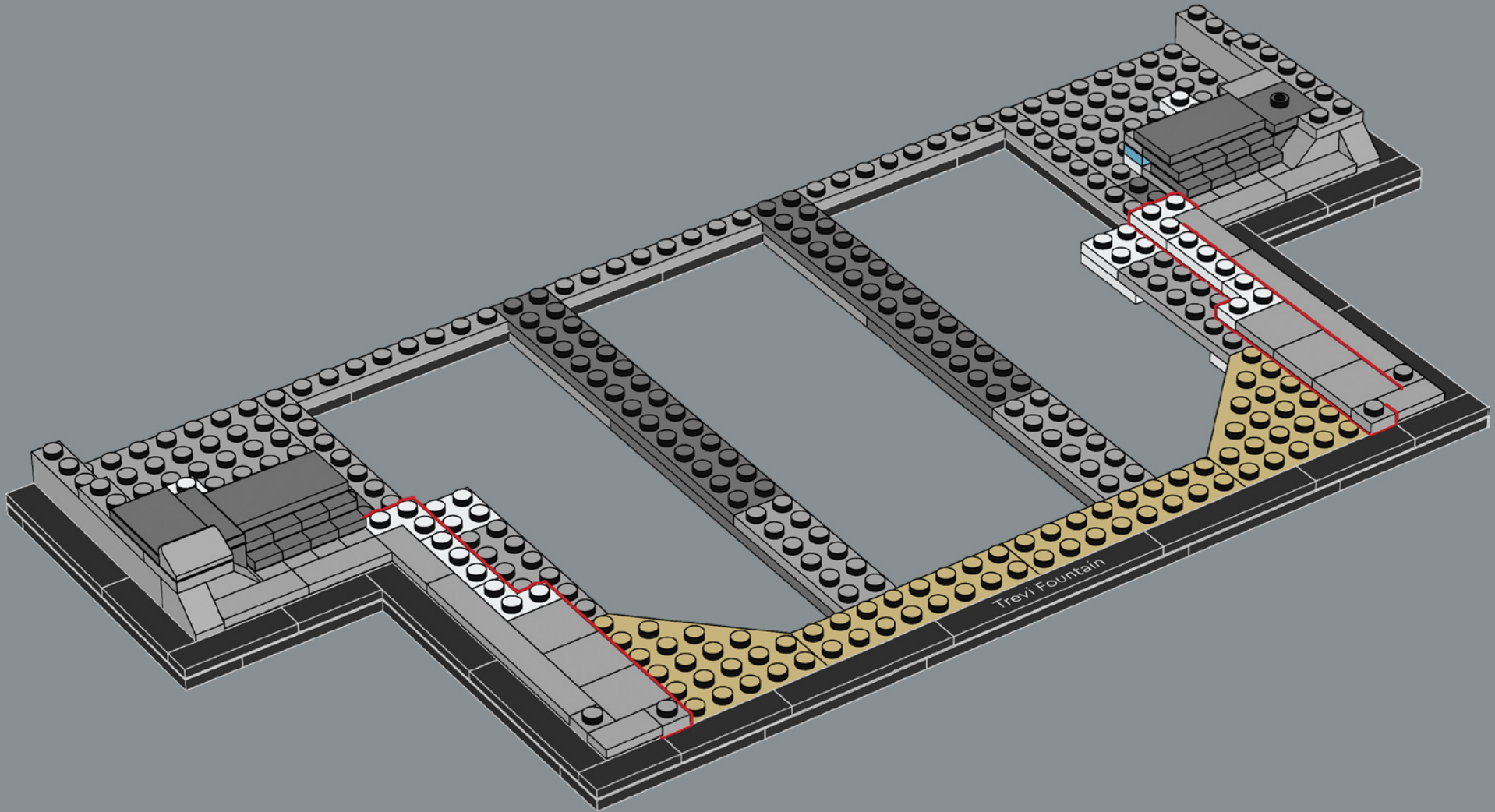

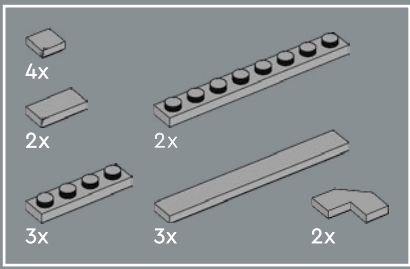

La Piazza di Trevi acoge a unos 10 millones de visitantes cada año. Esta afluencia la convierte en uno de los destinos turísticos más populares de Italia.

23

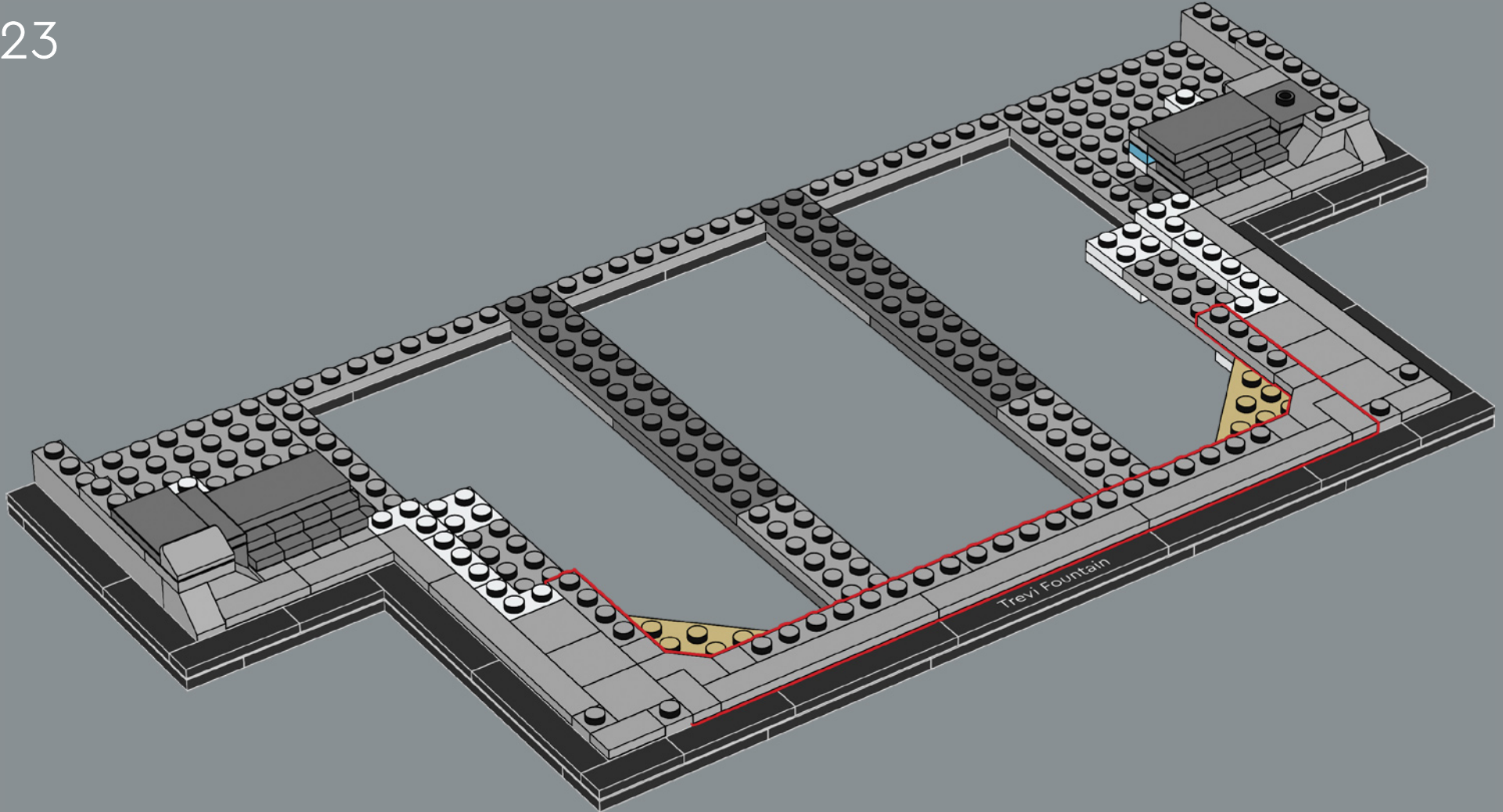

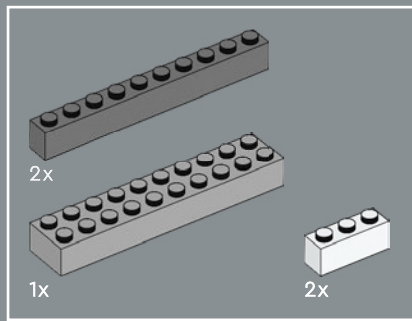

24

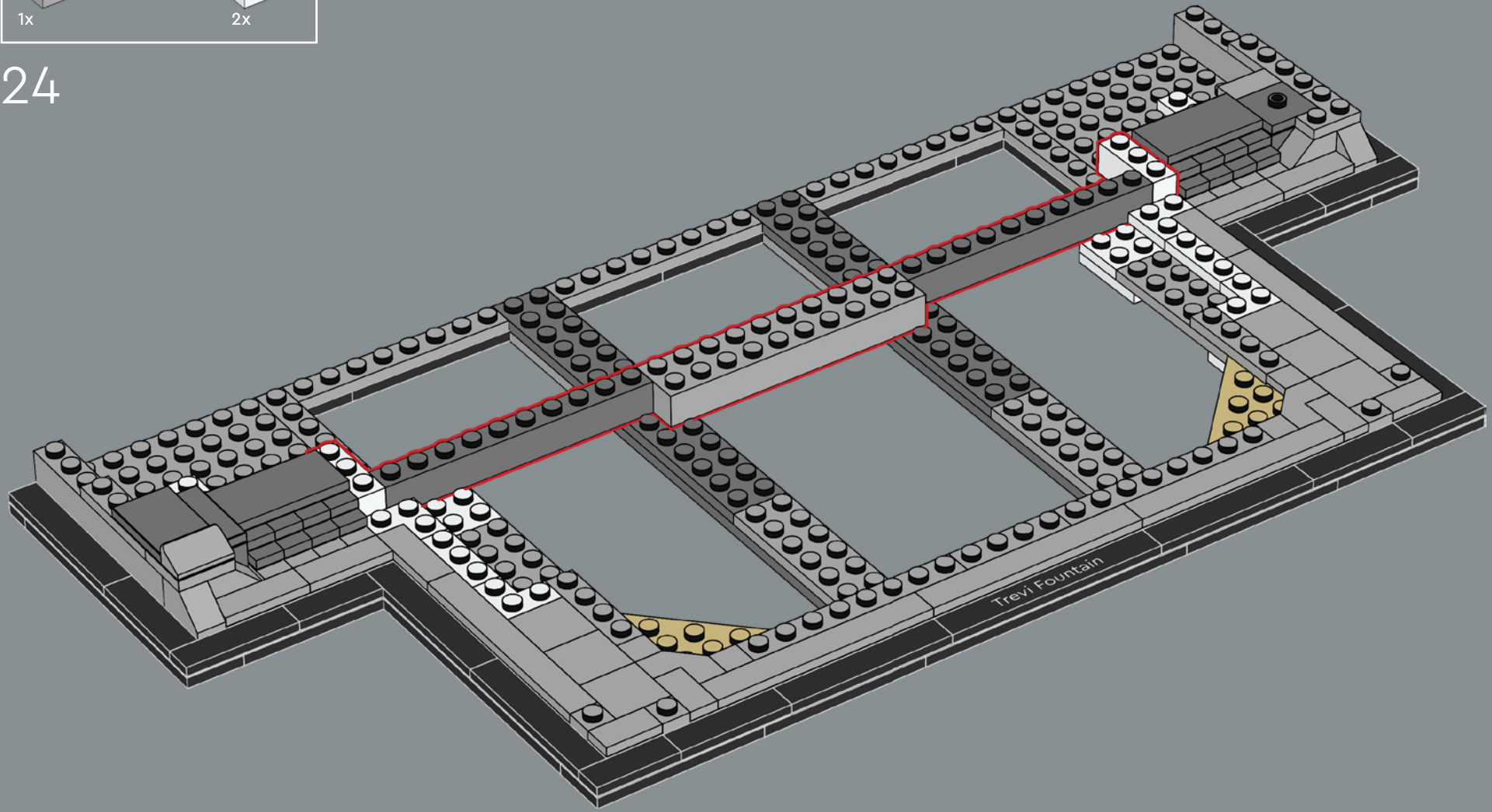

2x

25

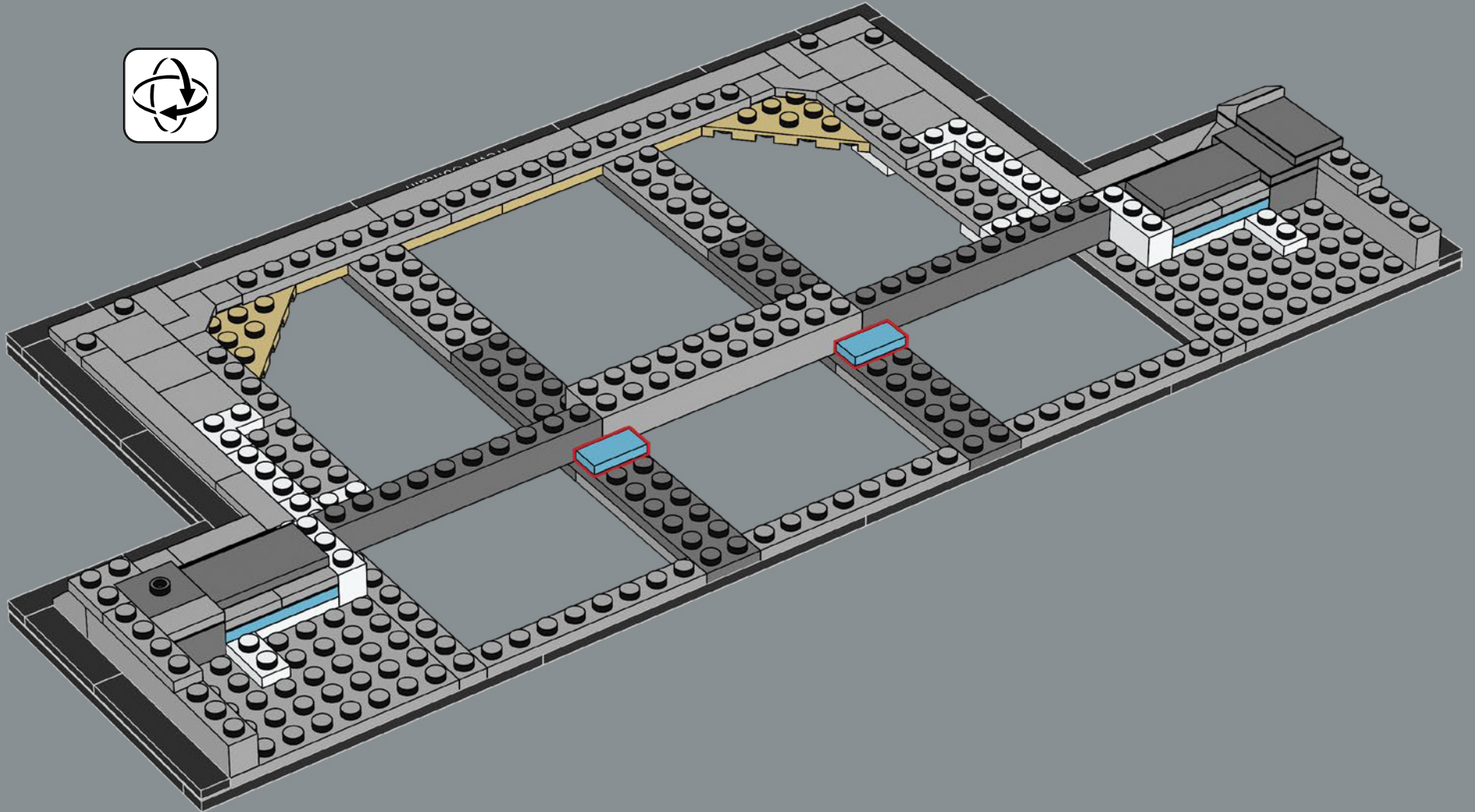

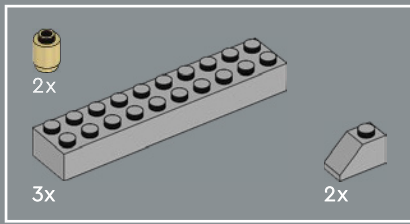

26

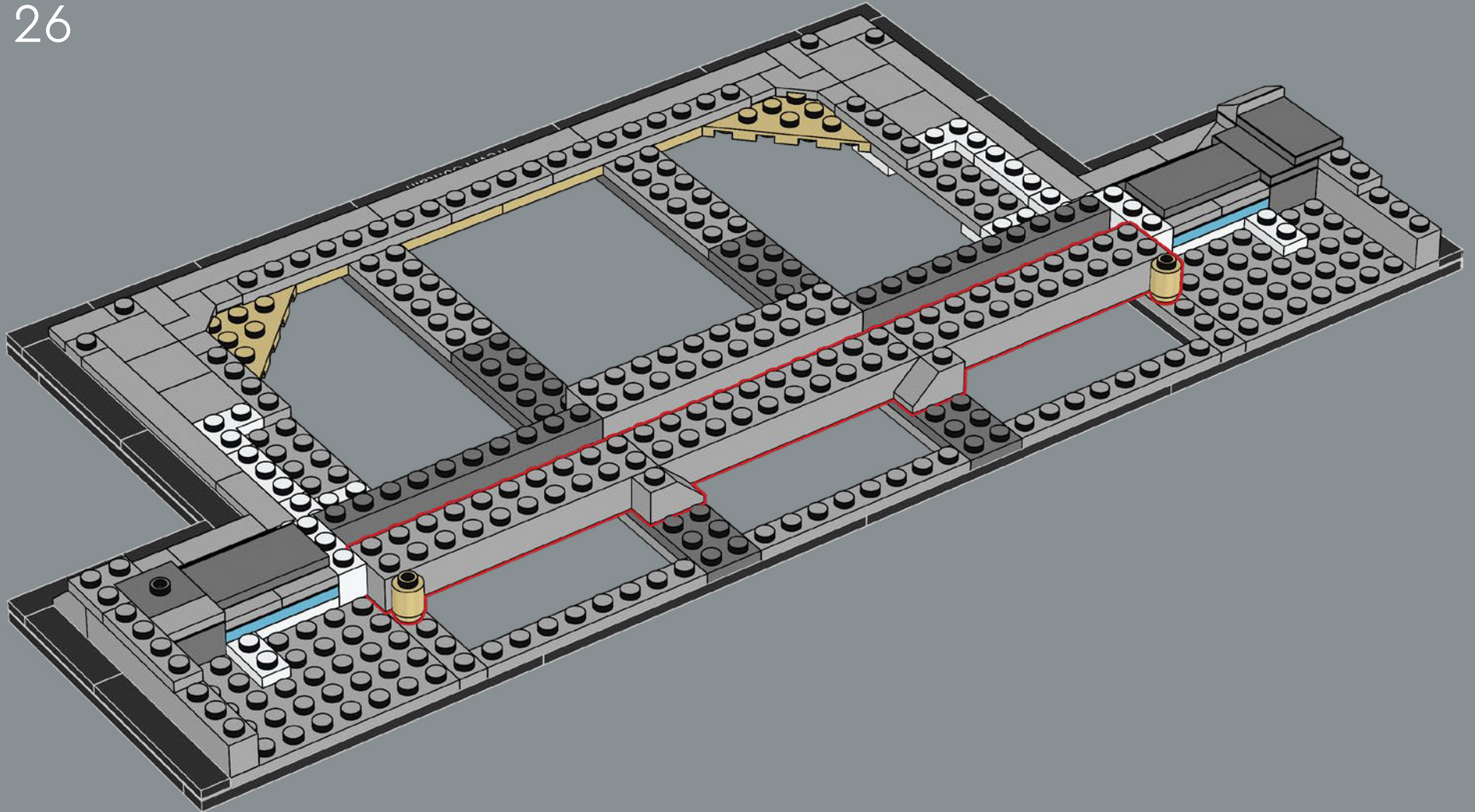

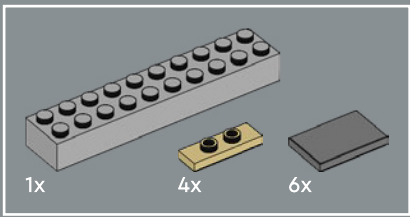

27

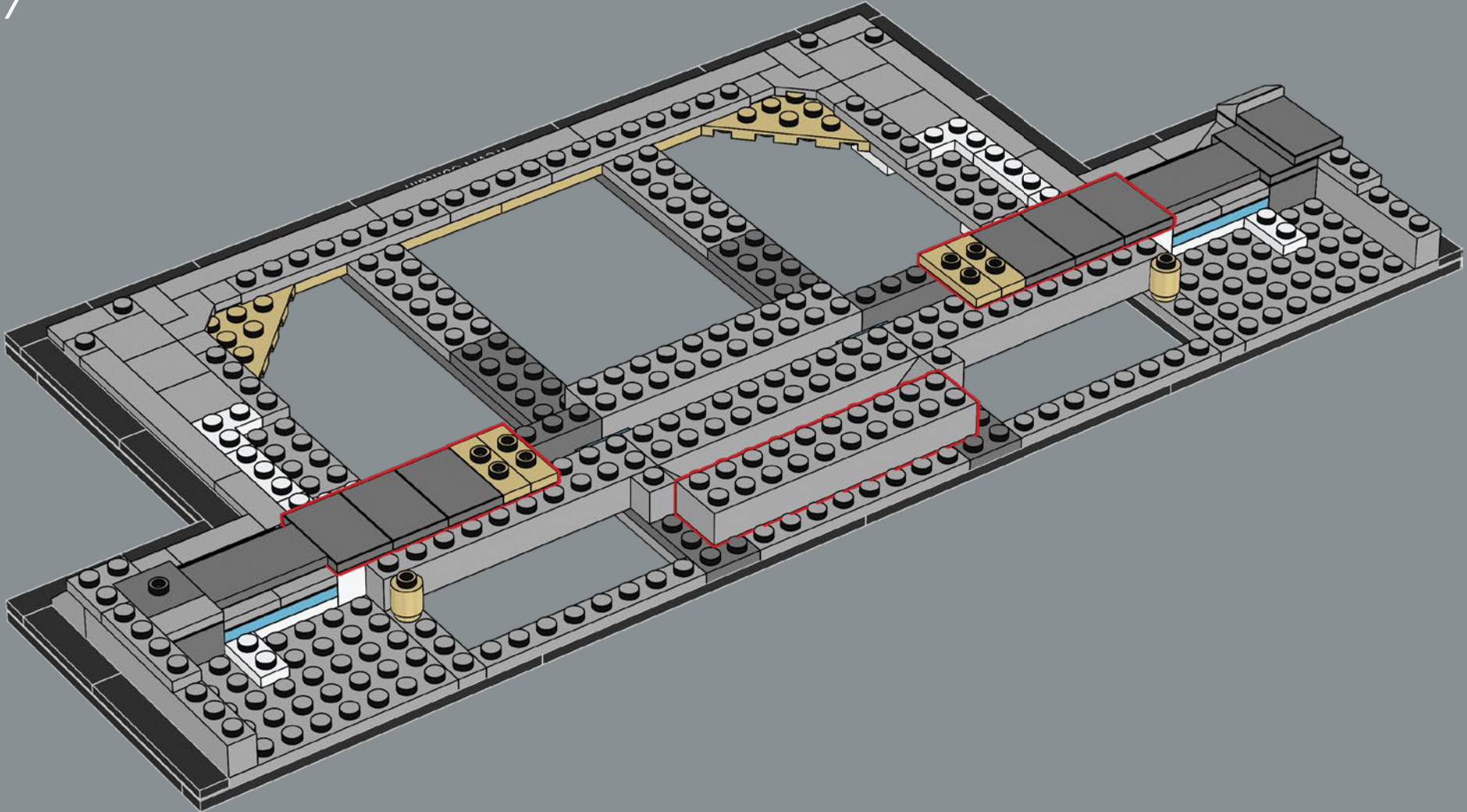



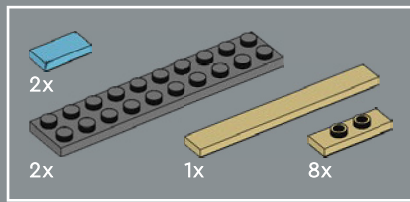

28

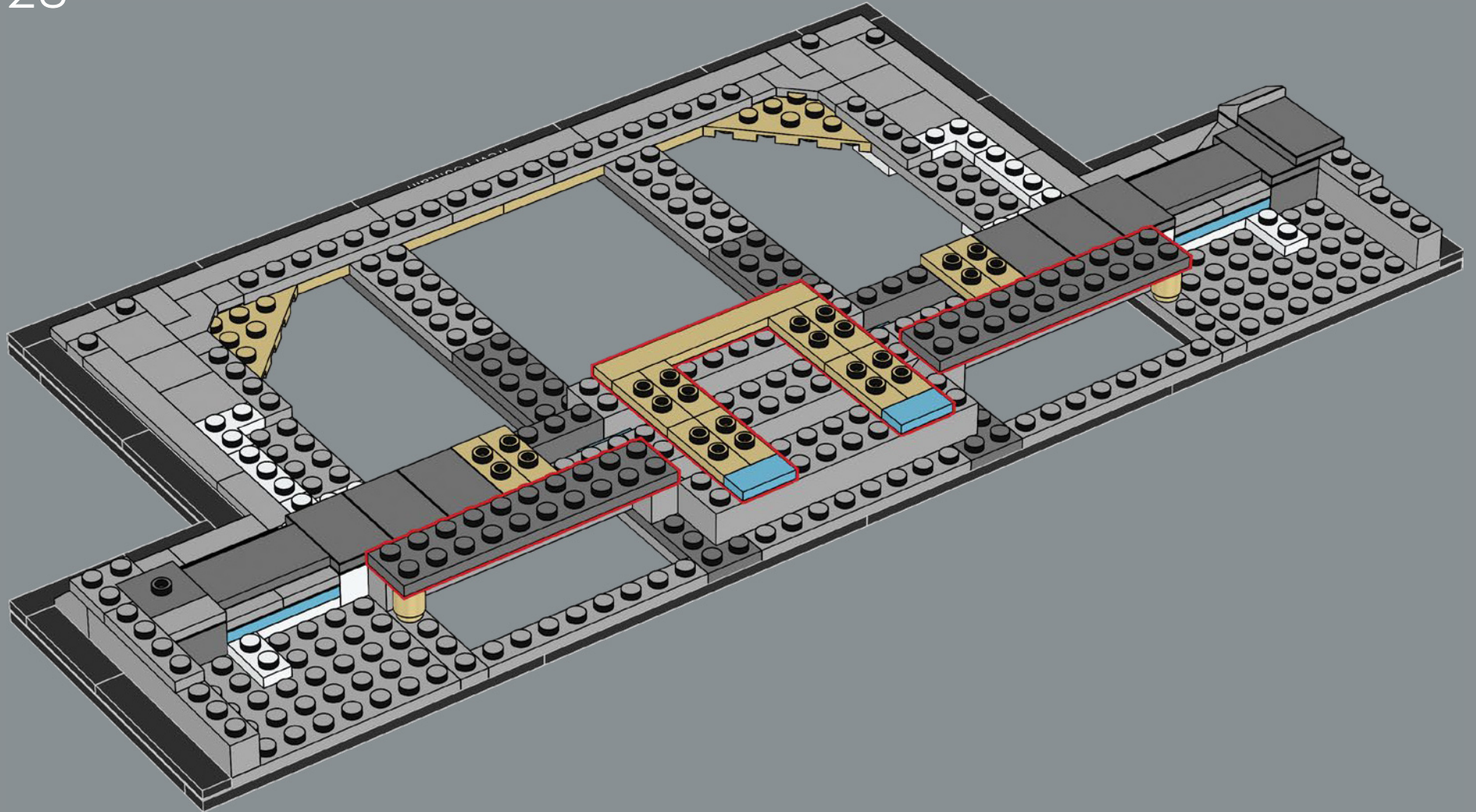

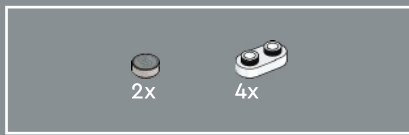

29

Según la tradición, si arrojas una moneda a la fuente, regresarás a Roma. Si lanzas dos monedas, te enamorarás de una persona que conocerás en la fuente. Si tiras tres, ¡estaréis juntos para siempre!

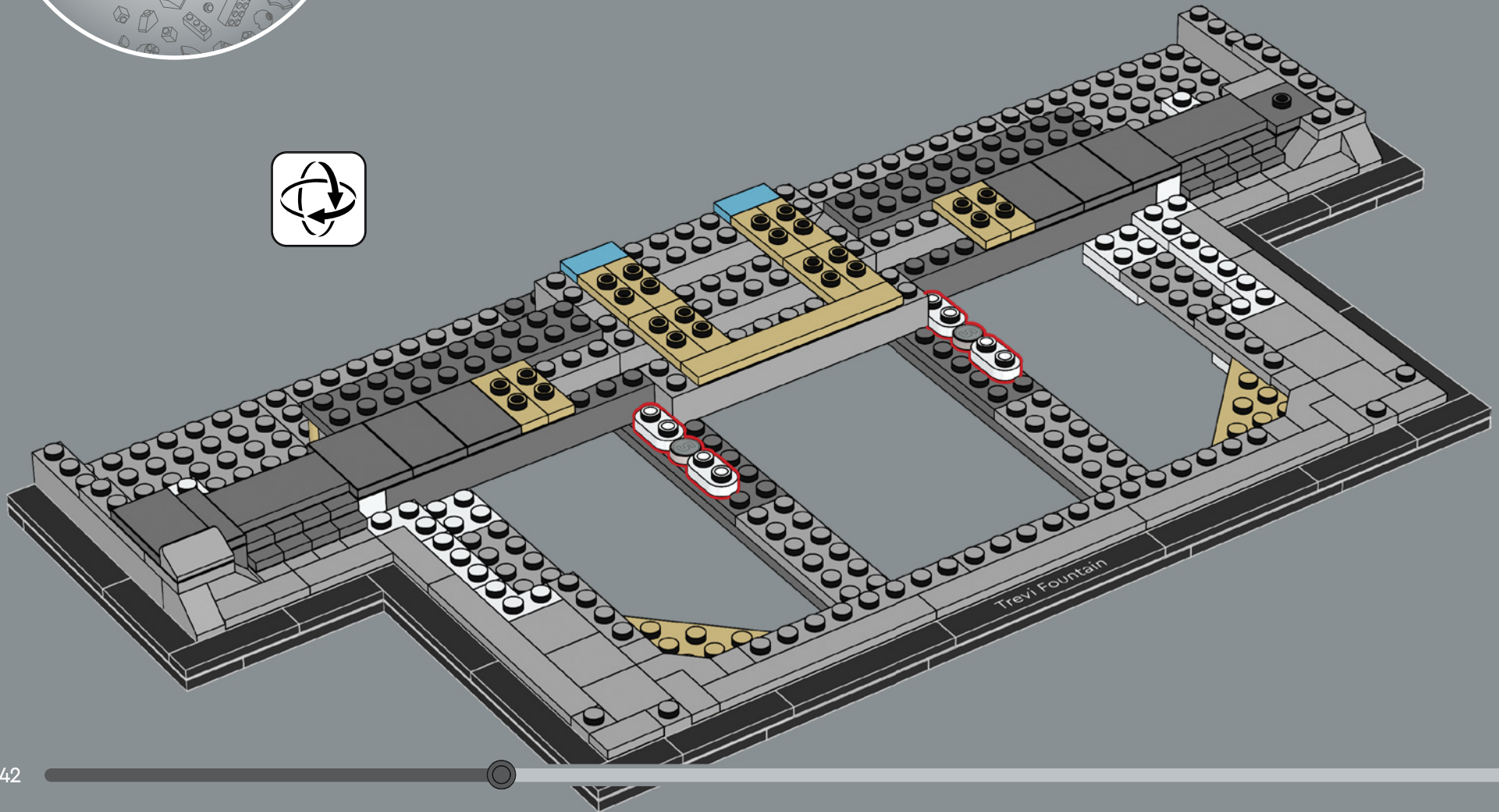

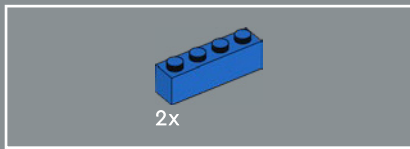

30

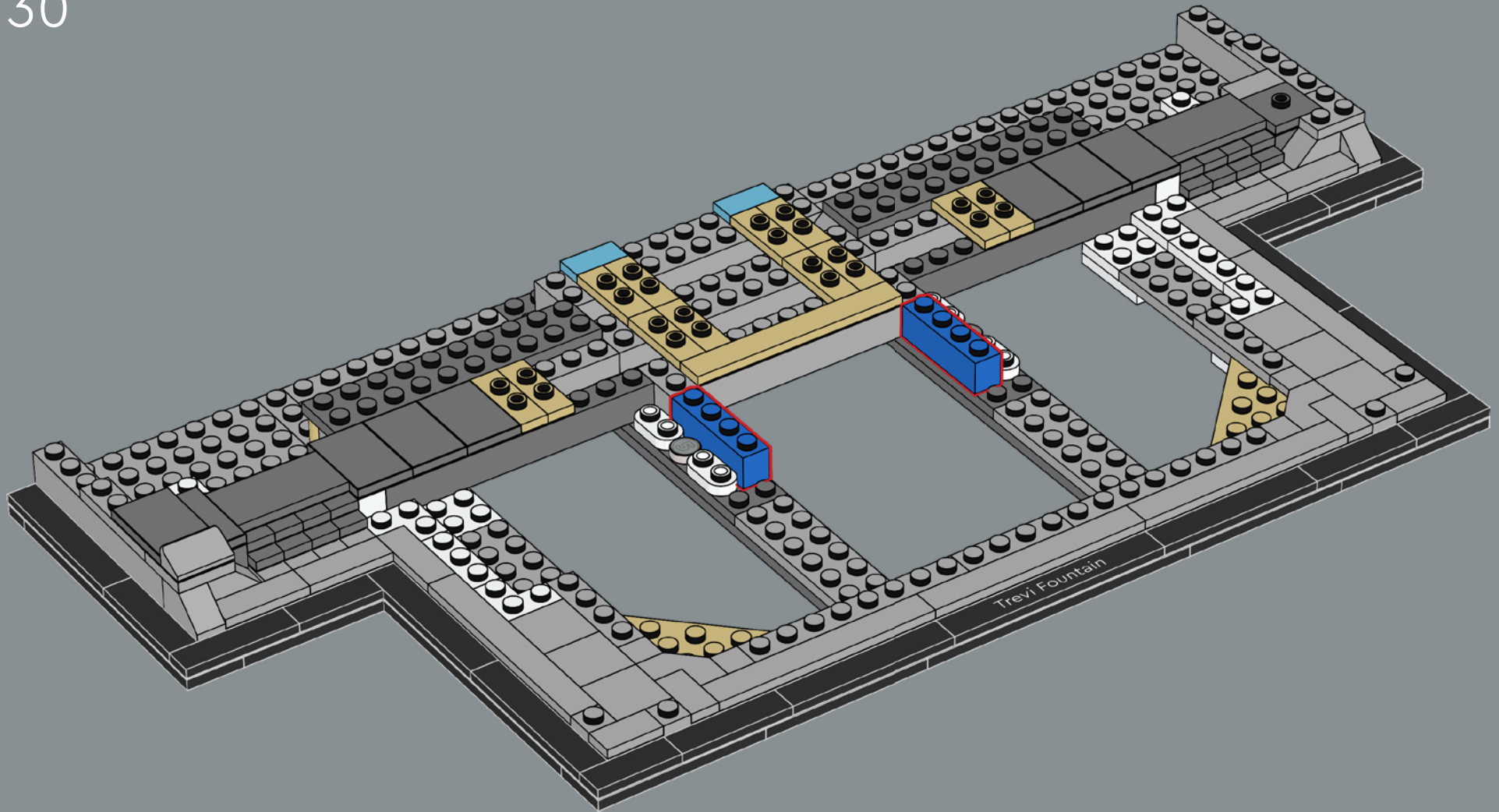

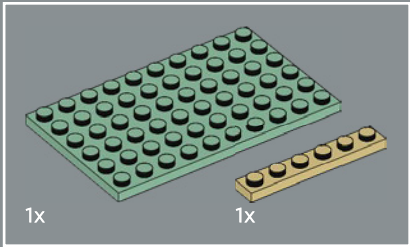
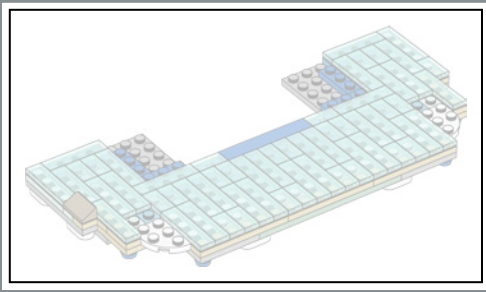

31

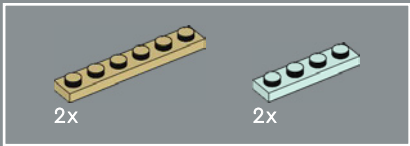
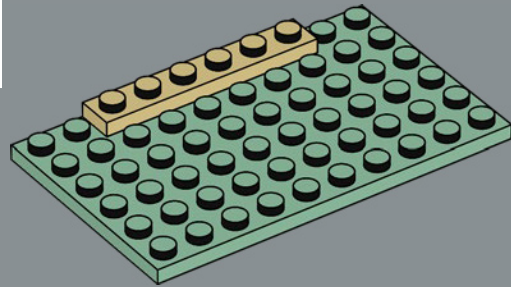

32

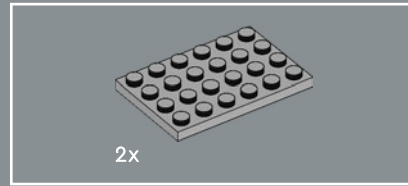
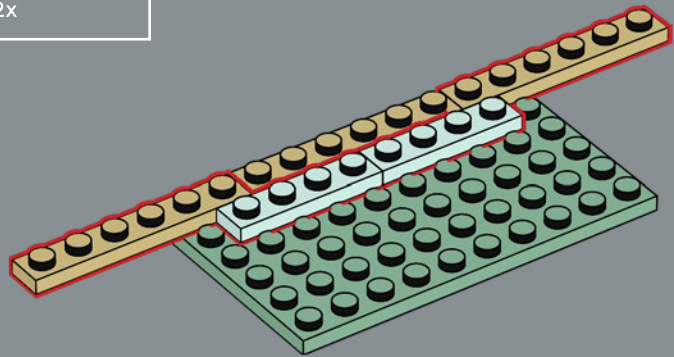

33

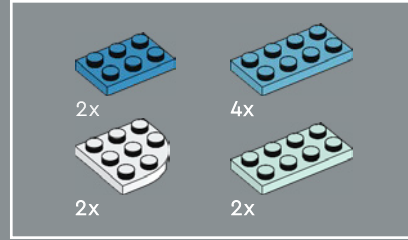
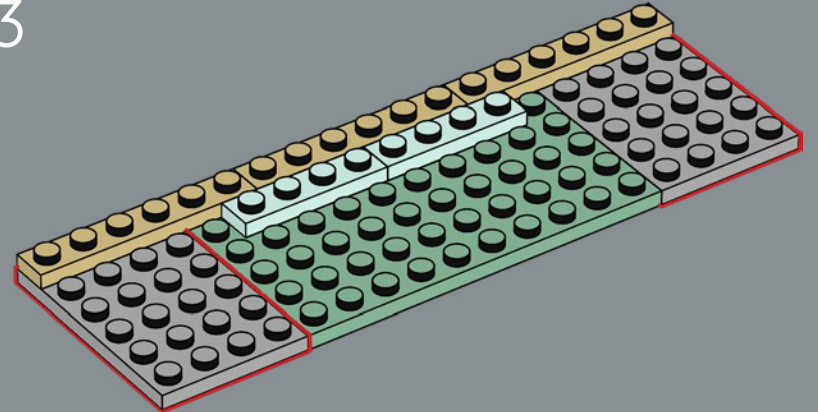

34

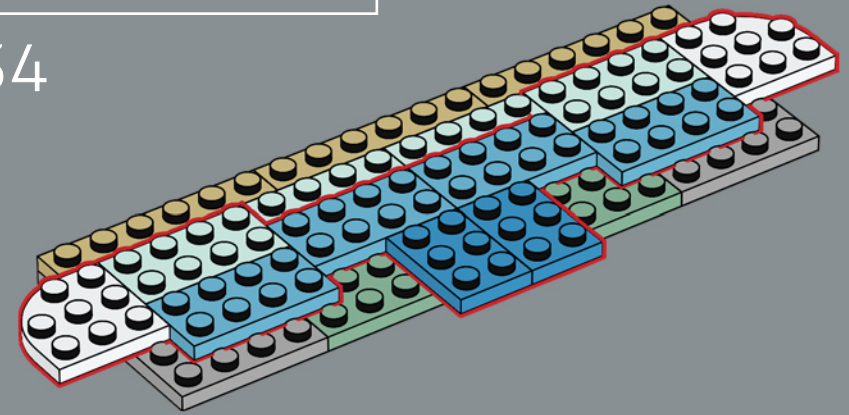

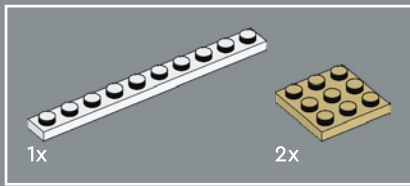

35

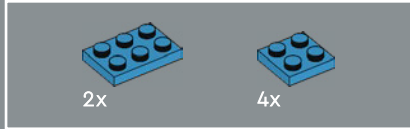
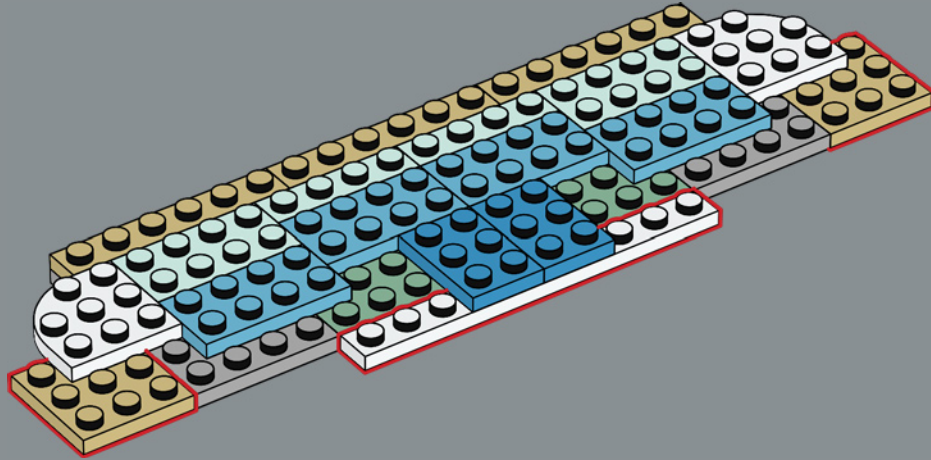

36

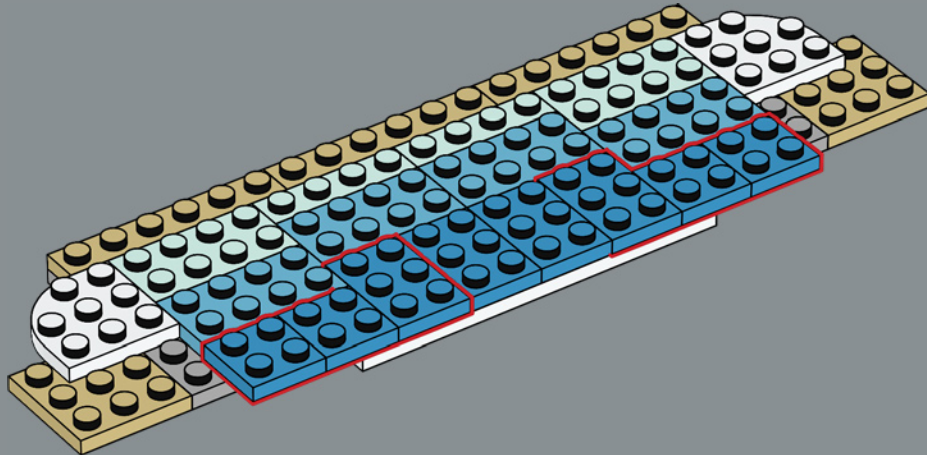

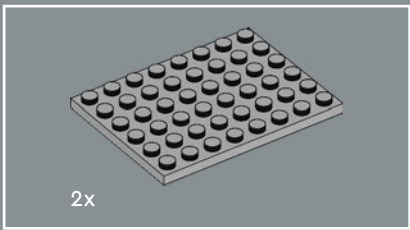

37

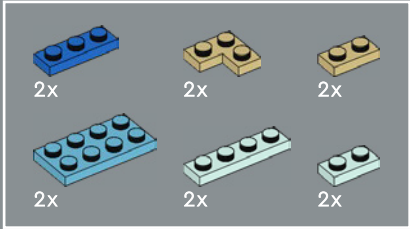
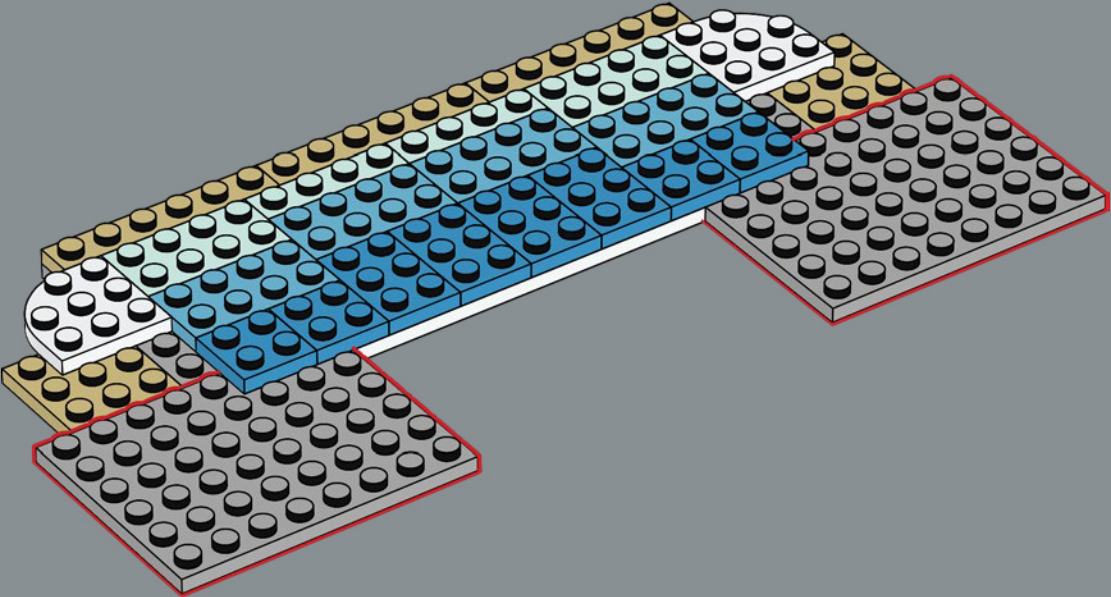

38

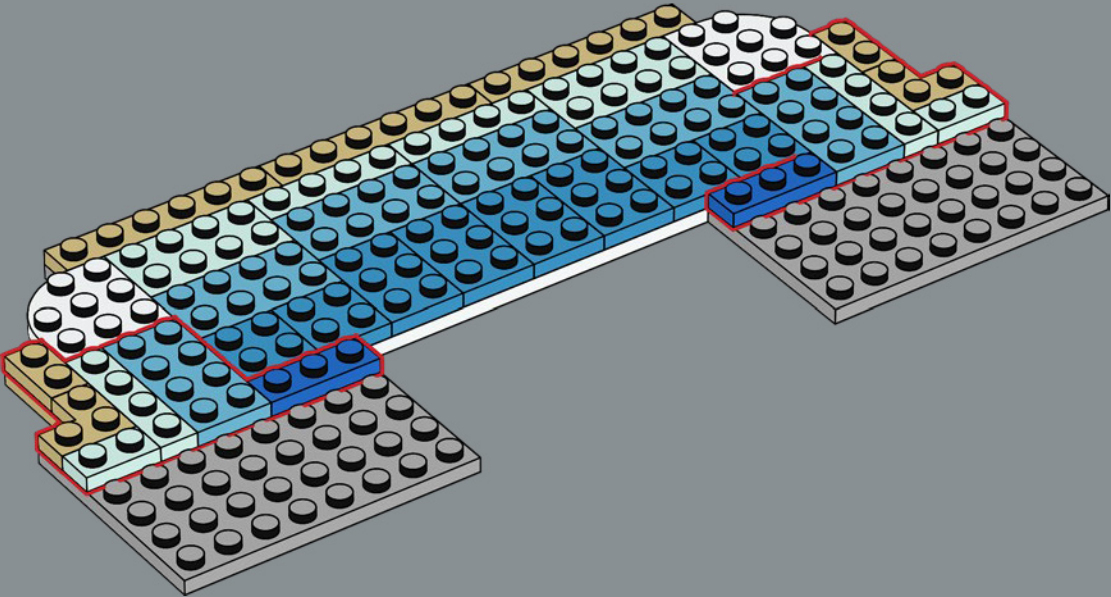

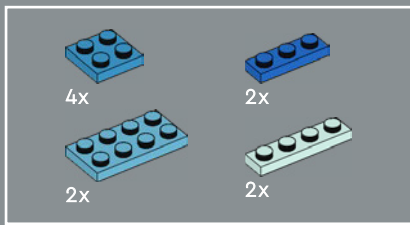

39

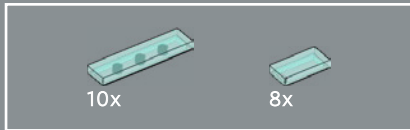
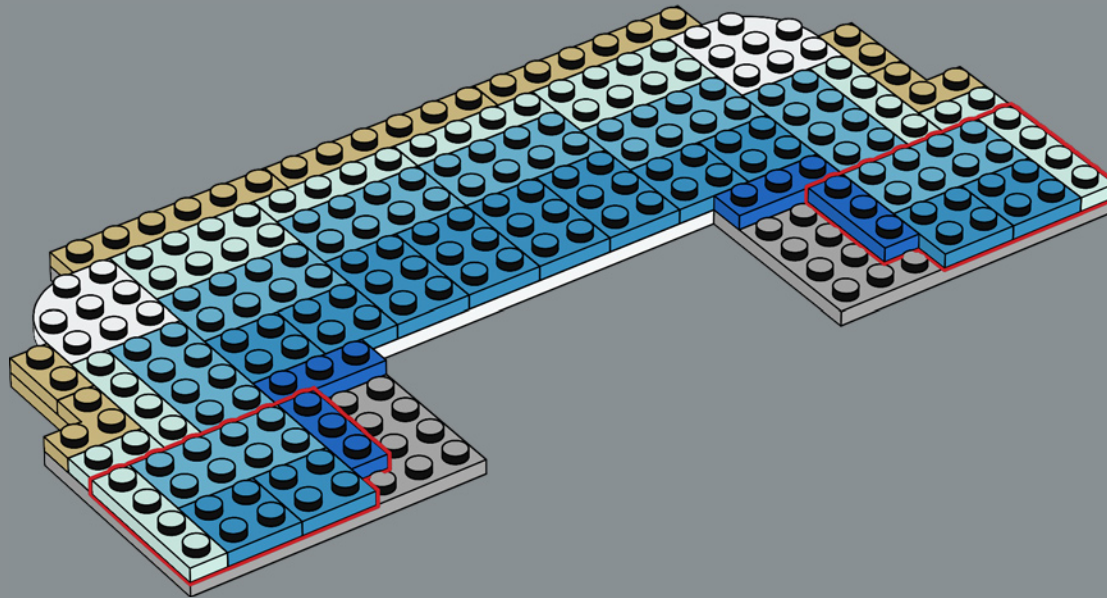

40

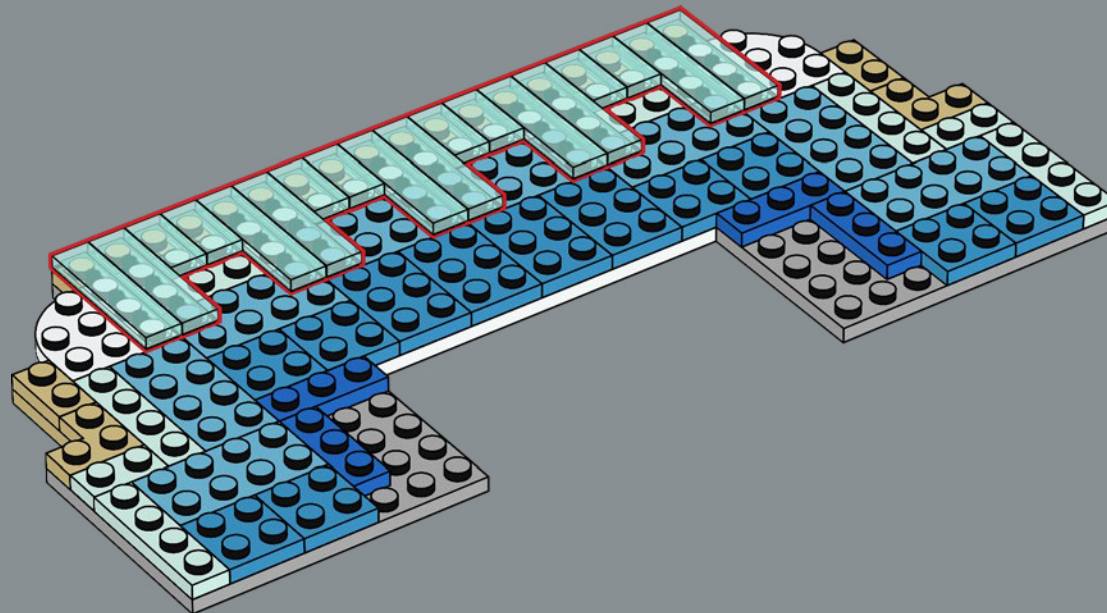

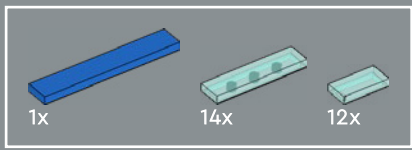

41

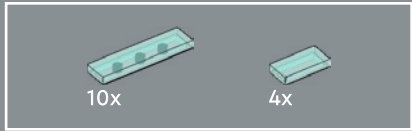
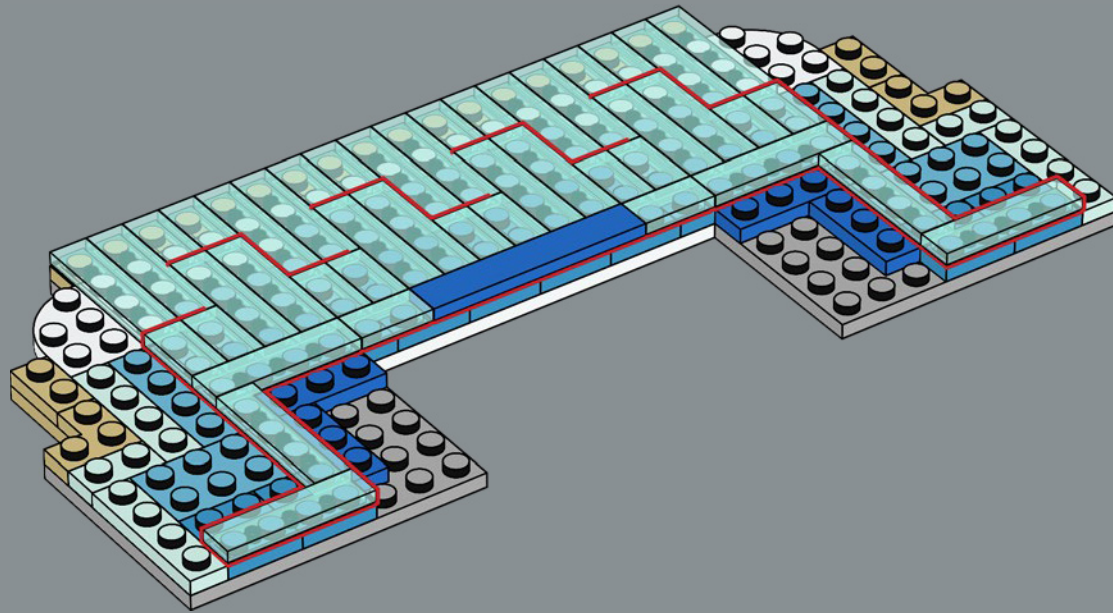

42

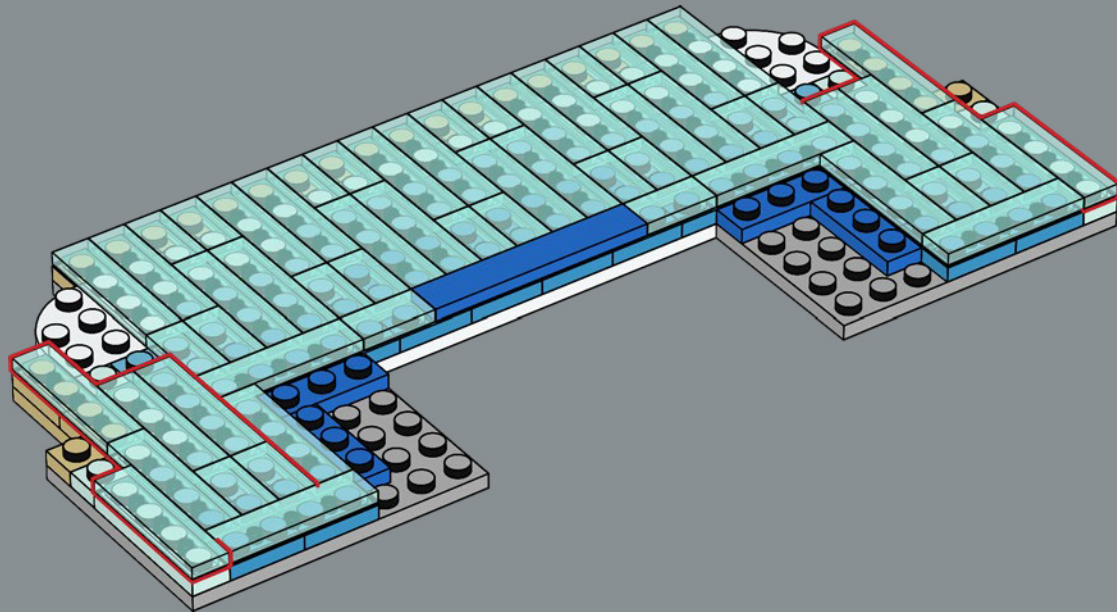



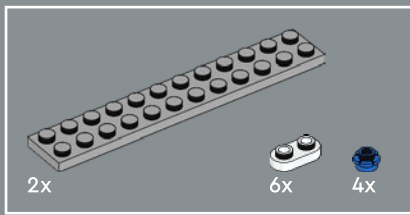

43

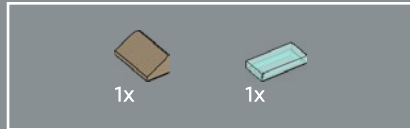
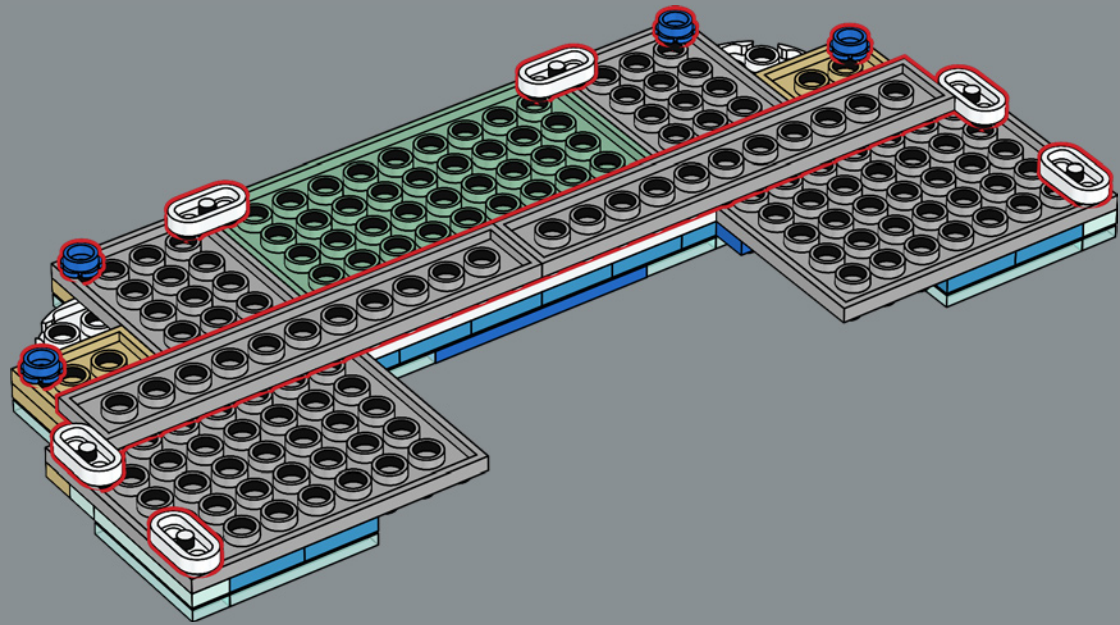

44

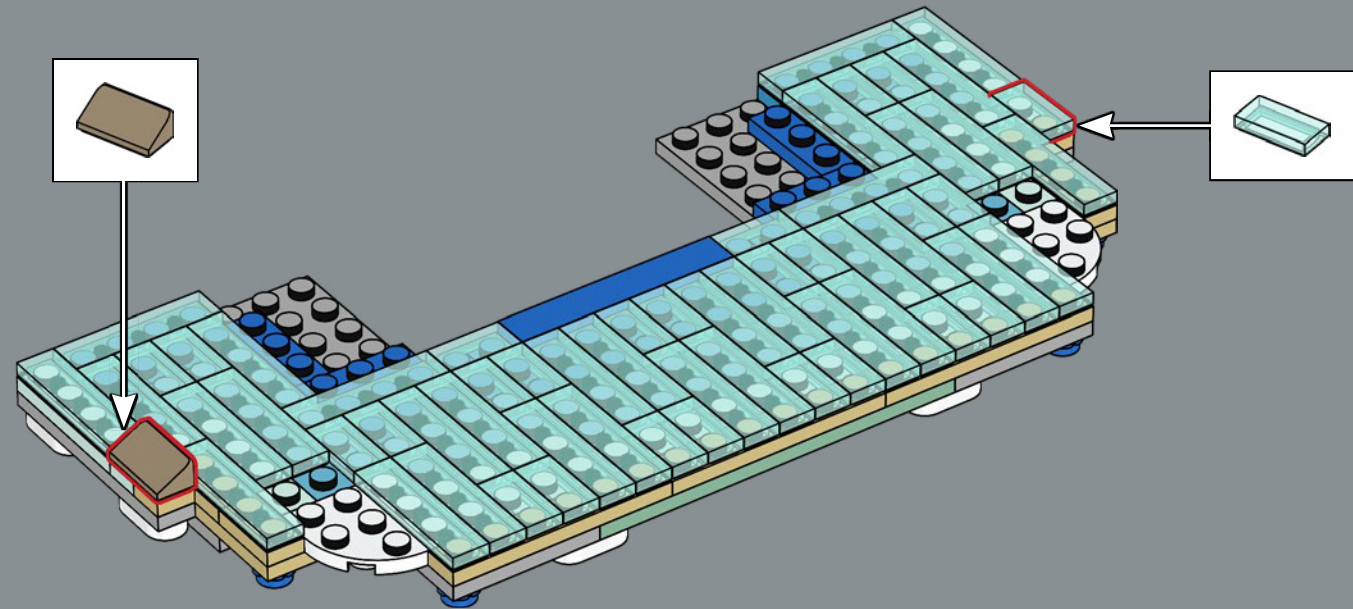

Se estima que se arrojan unos 3000 € diarios a la fuente. Las monedas se recuperan al final del día y una gran parte de ellas se entregan a organizaciones benéficas.

45

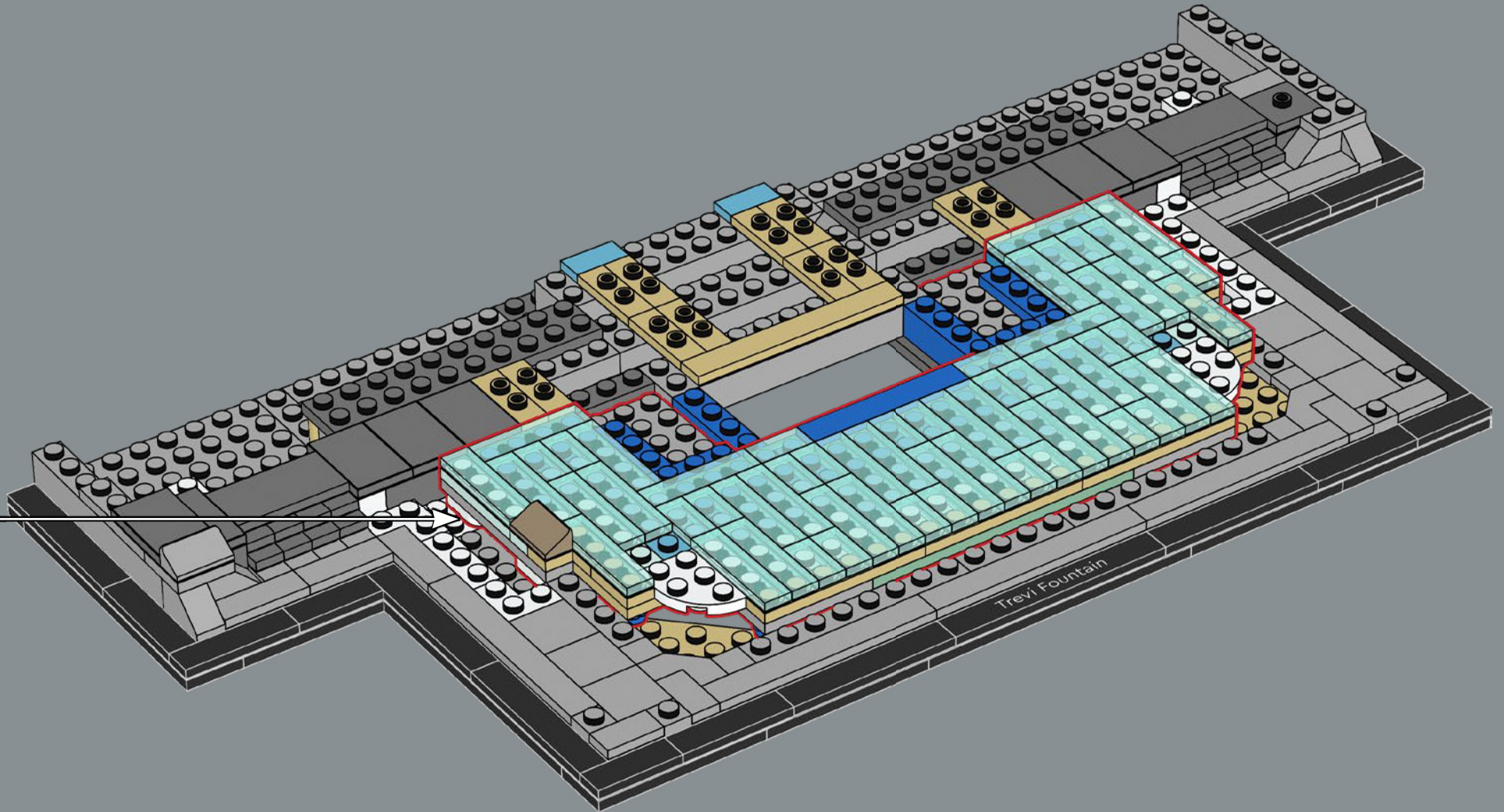



46

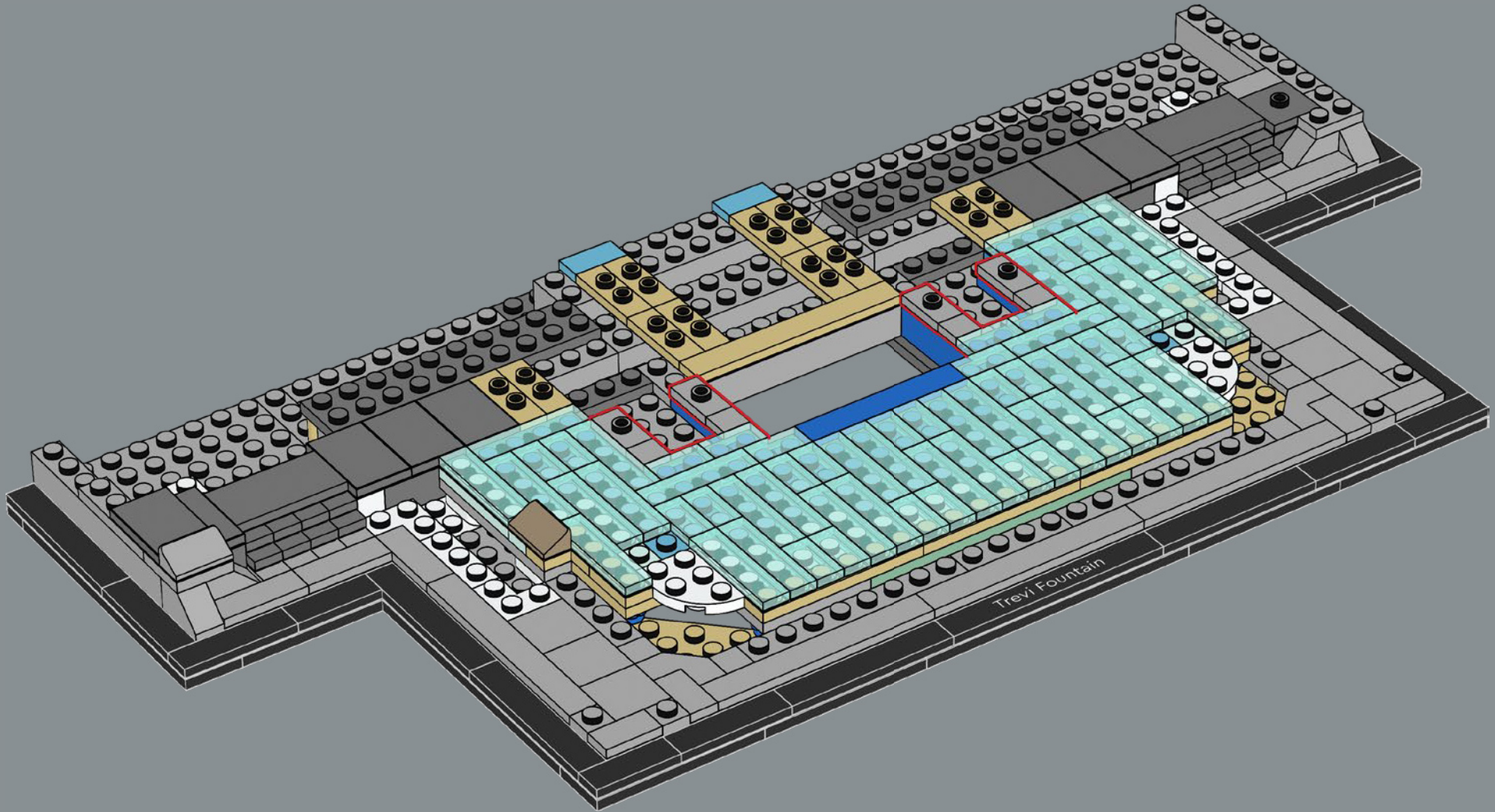

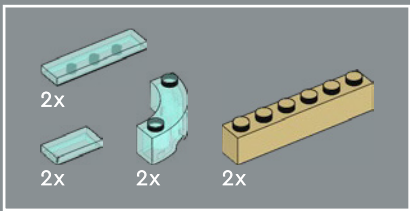

47

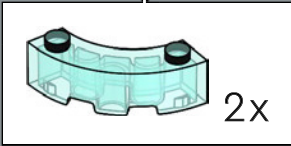
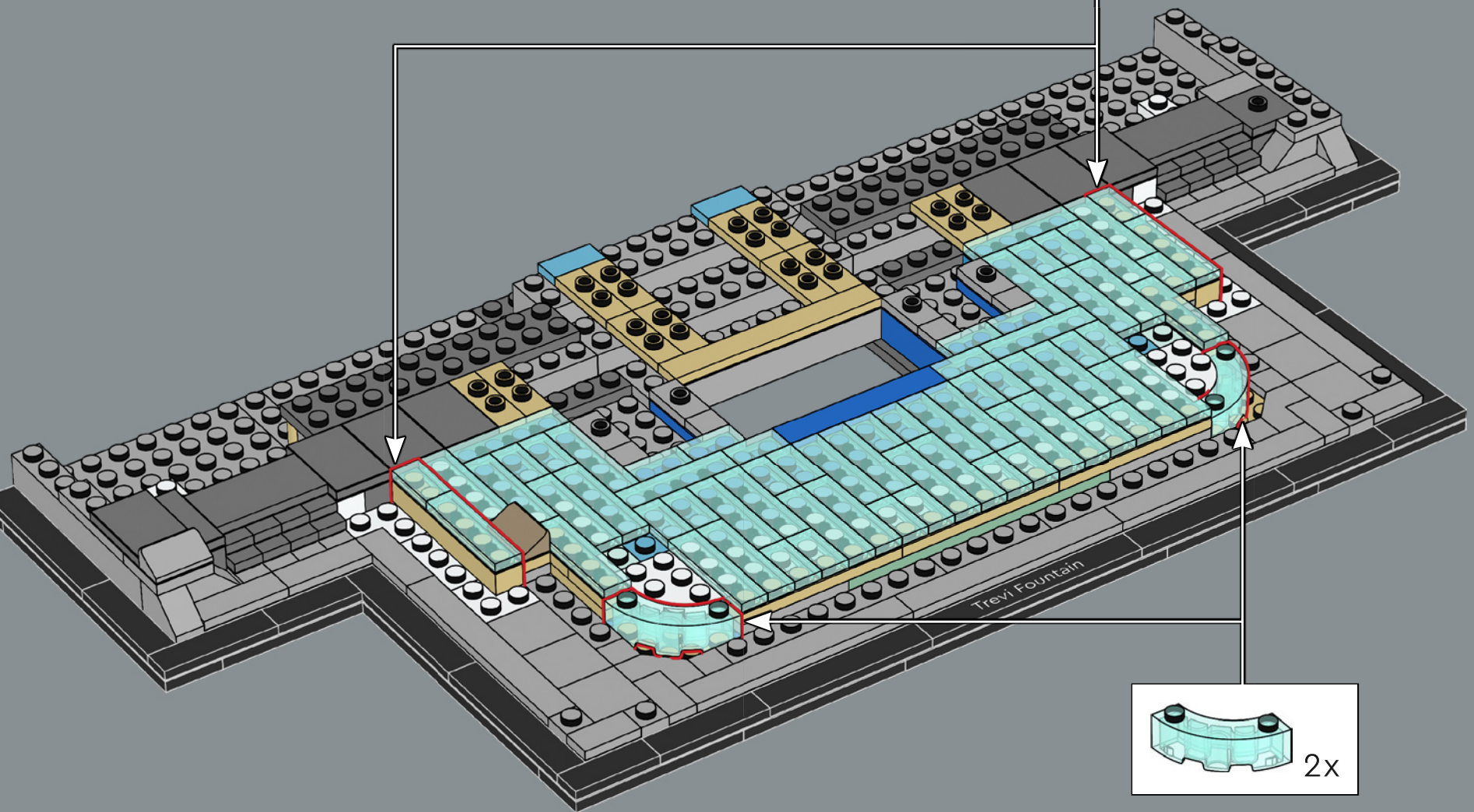
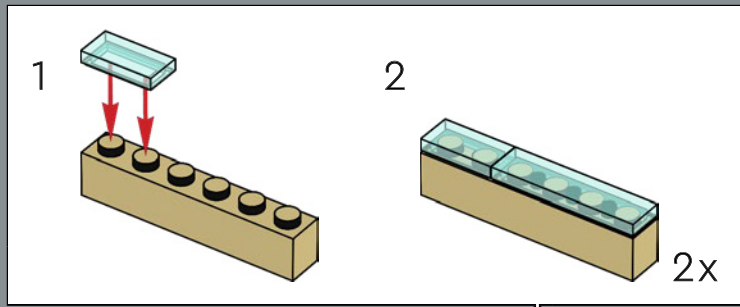

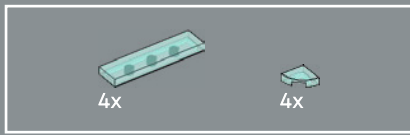

48

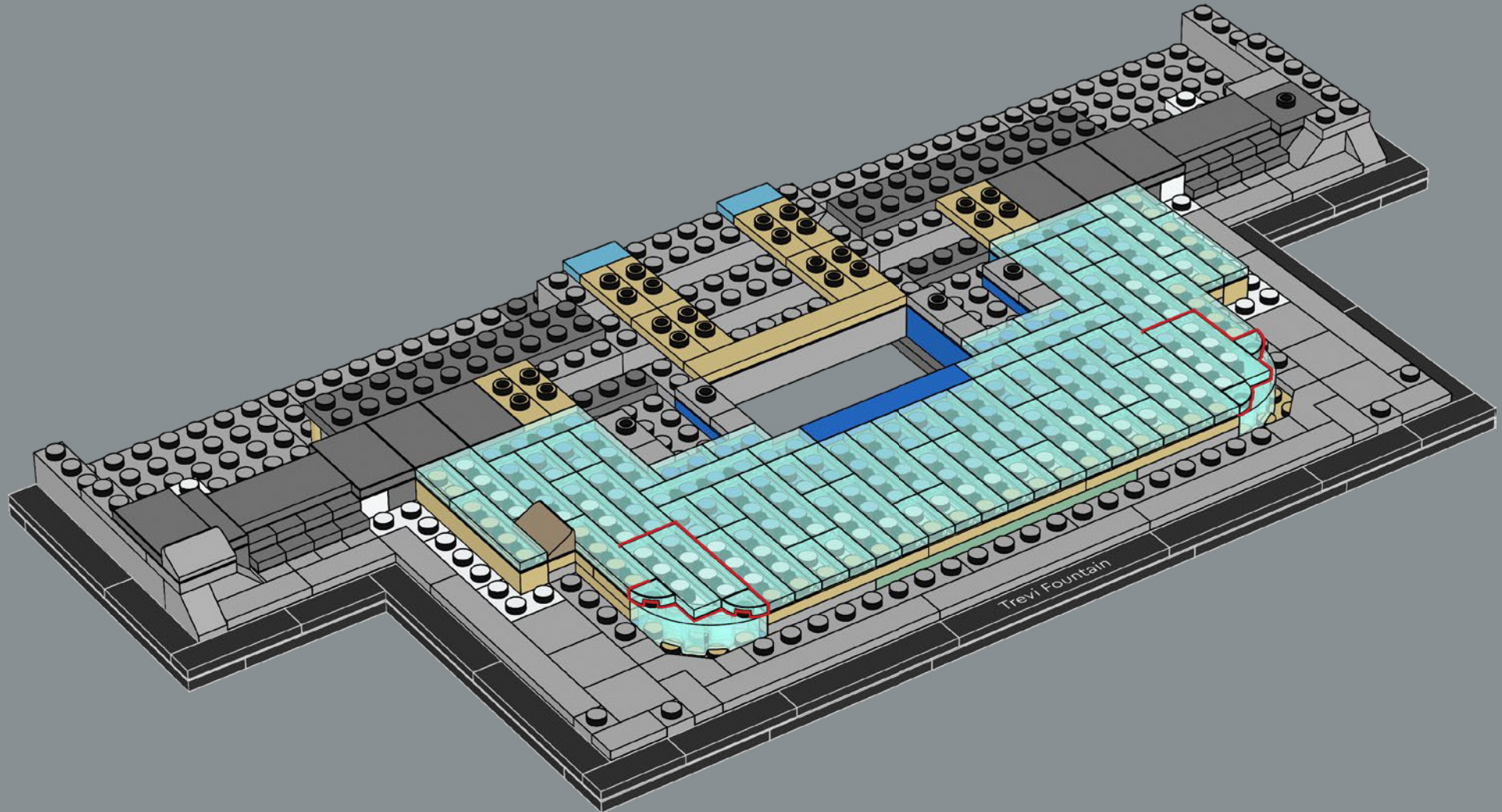

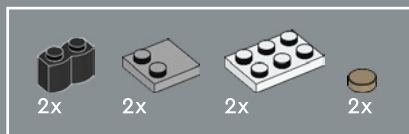

49

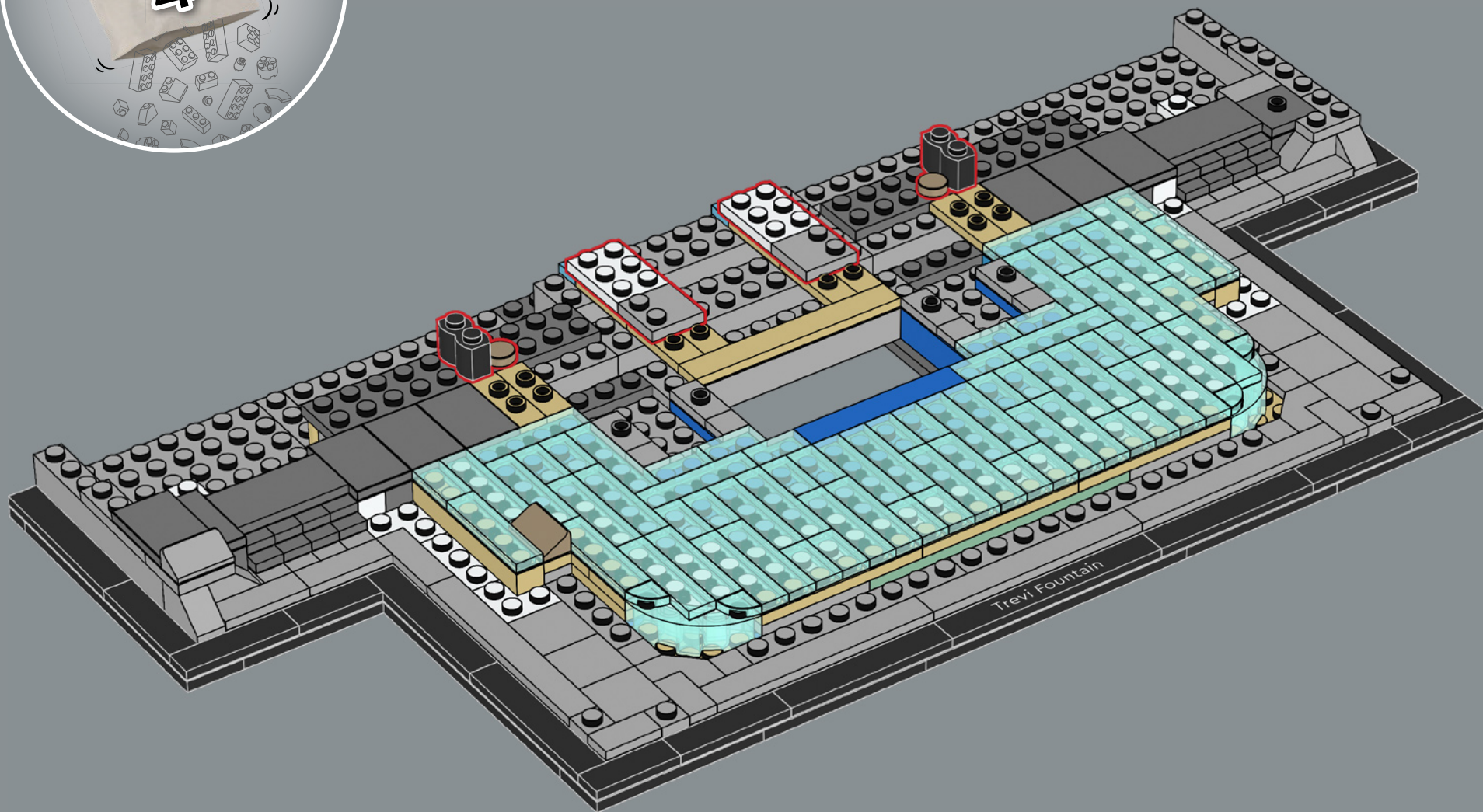

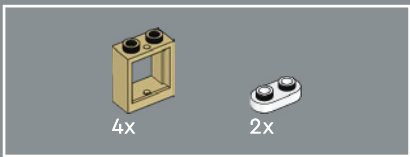

50

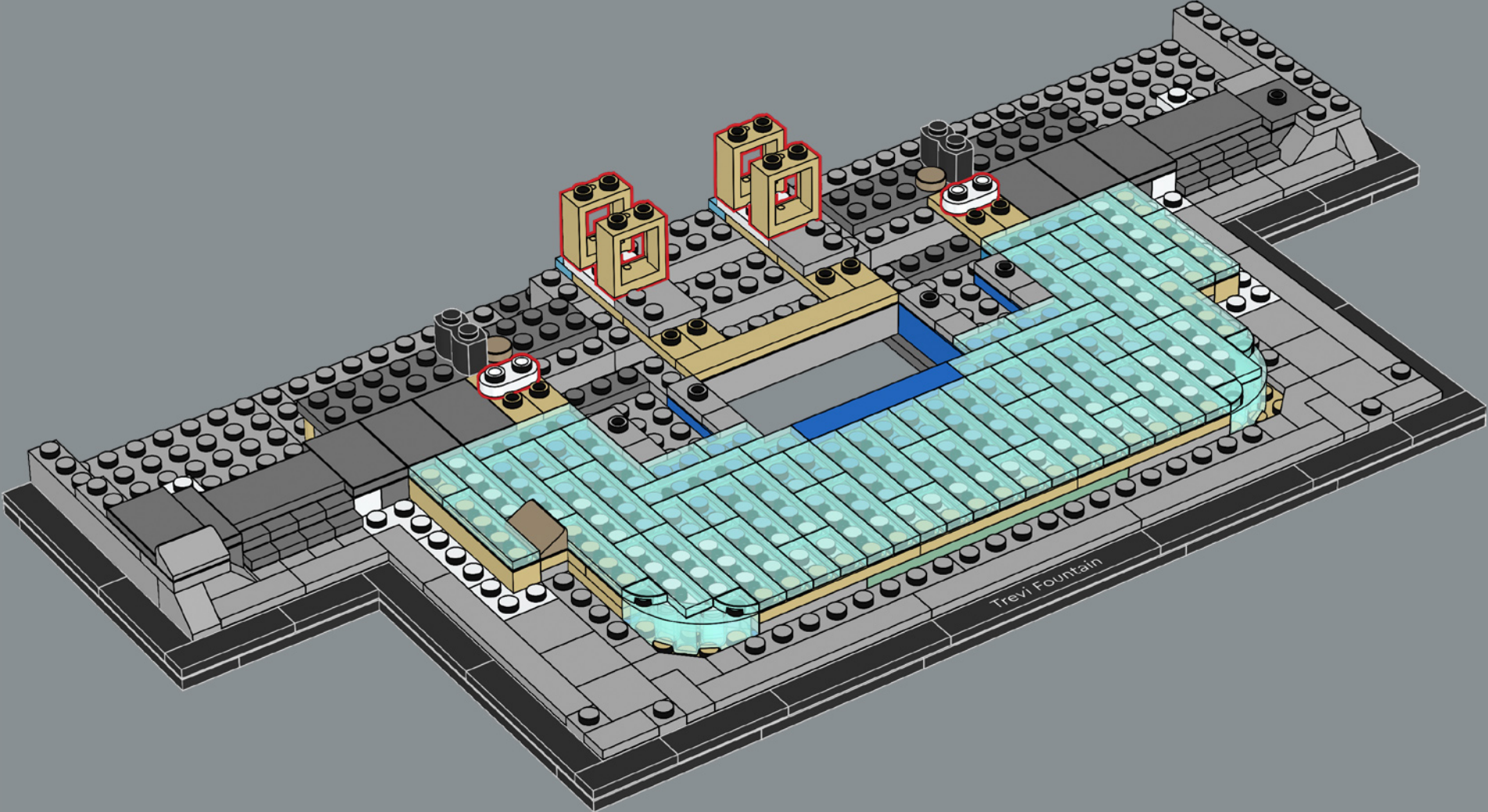

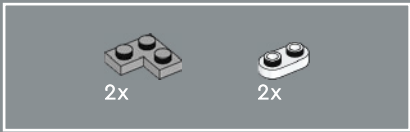

51

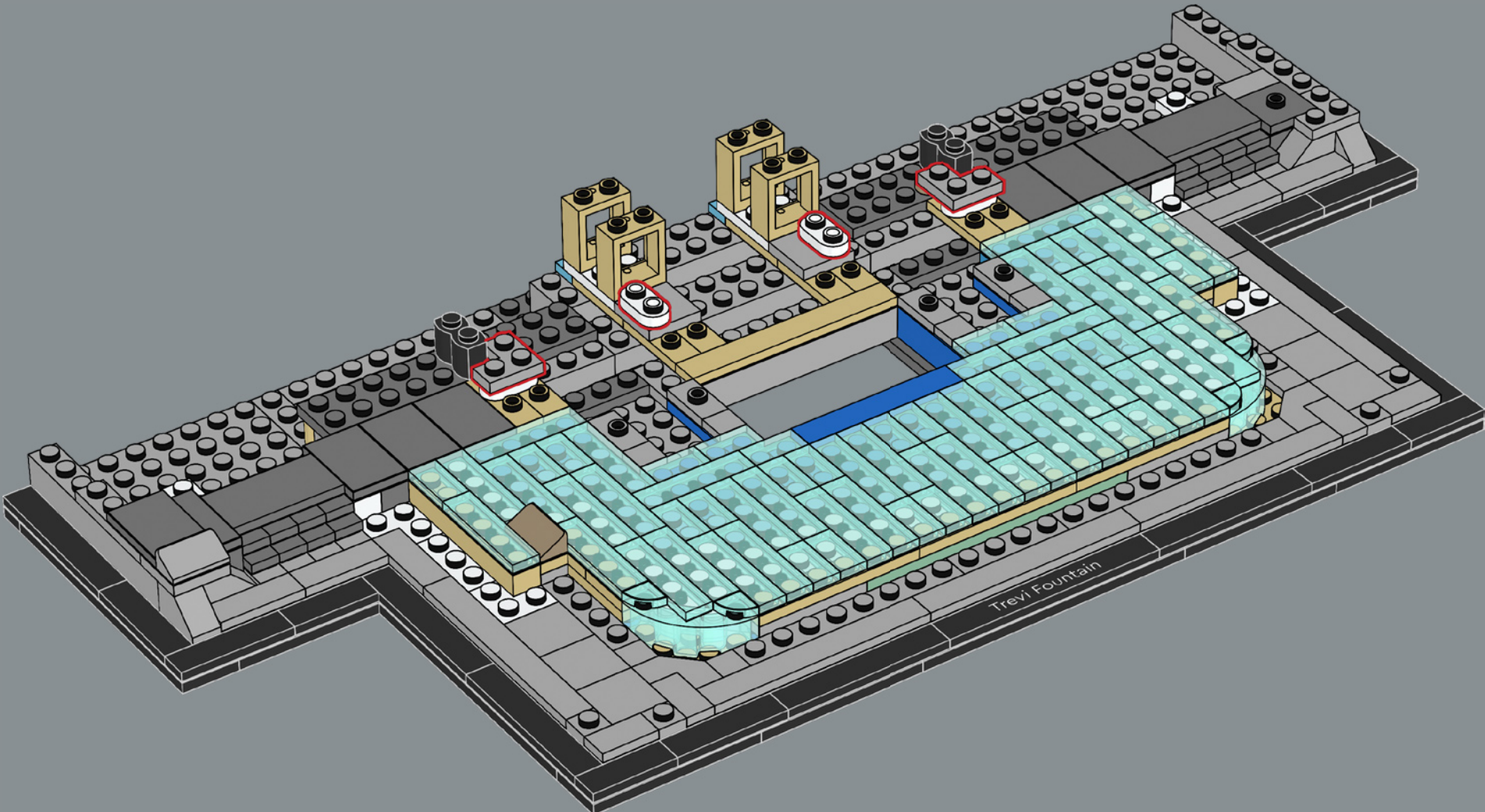



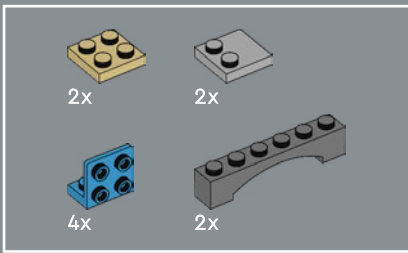

52

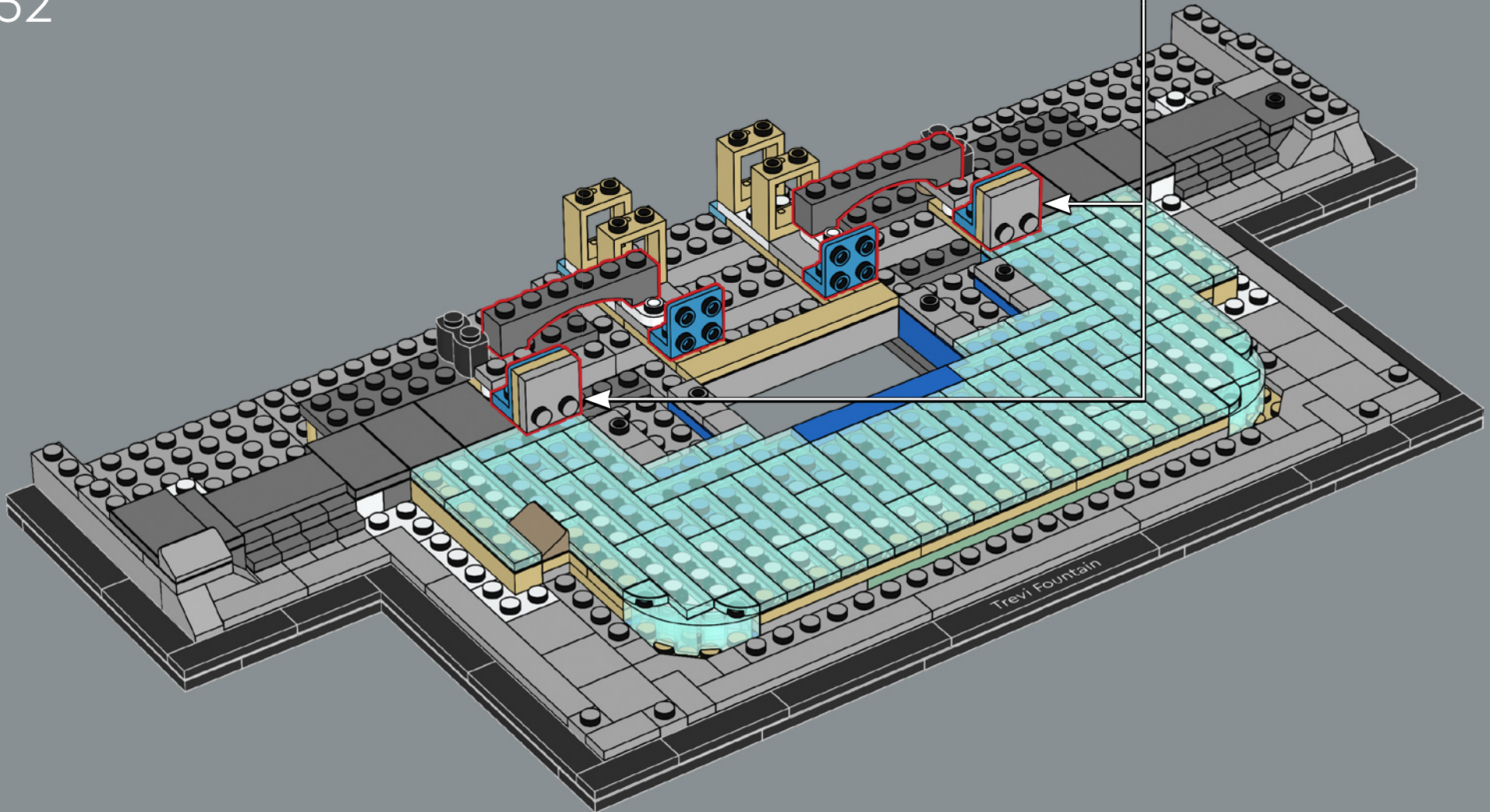
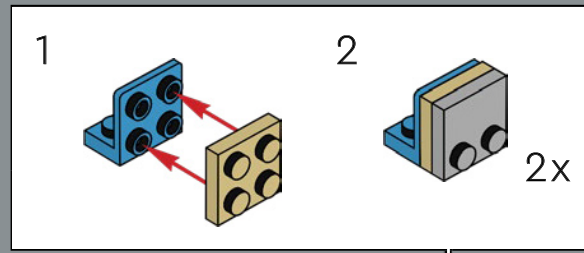

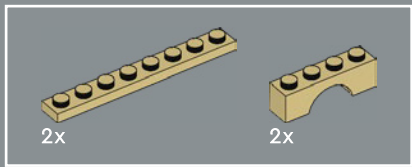

53

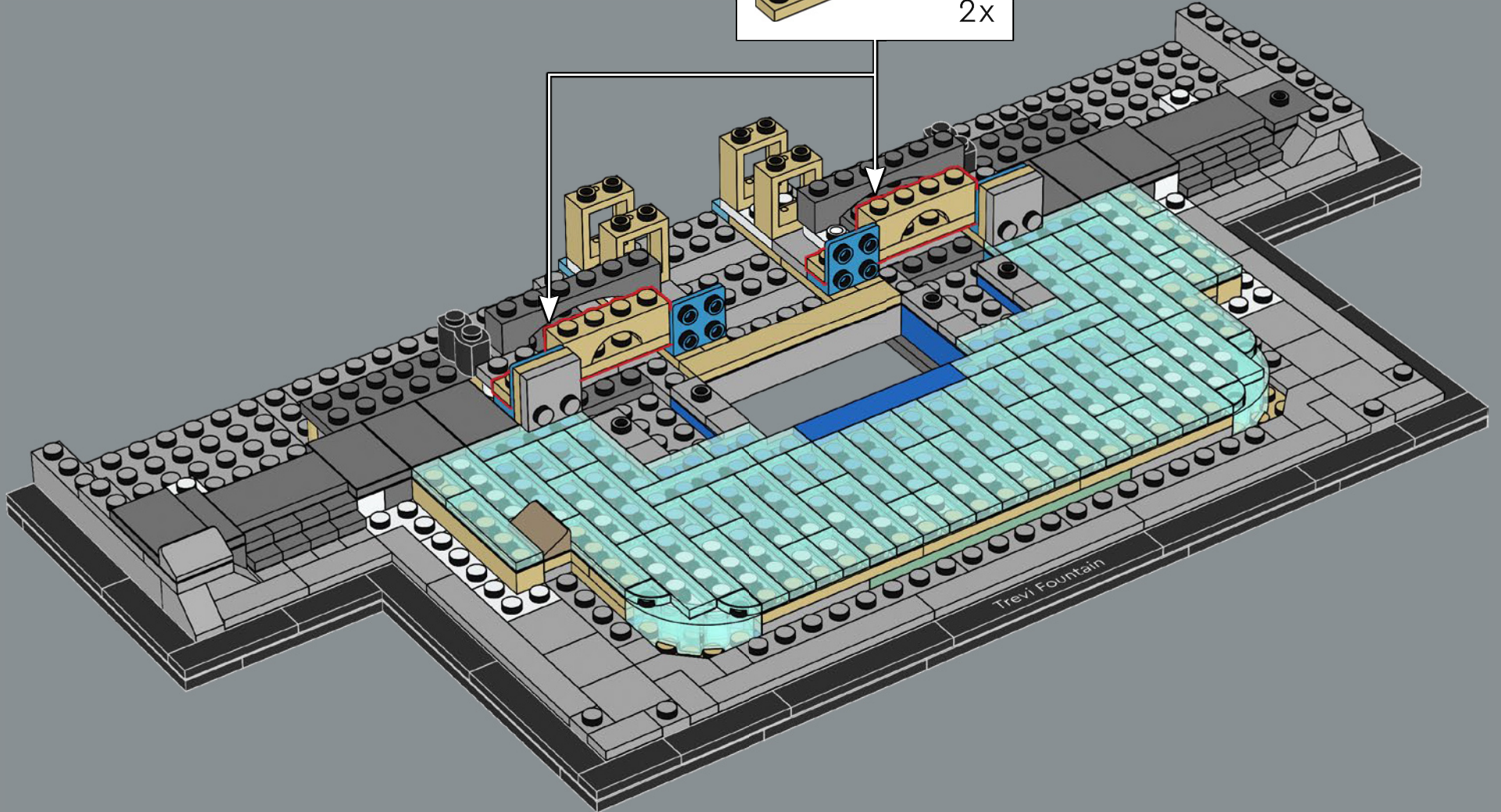
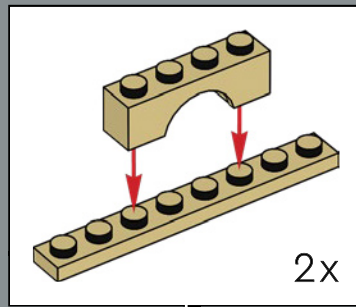

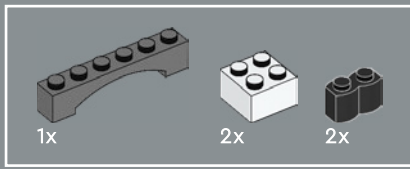

54

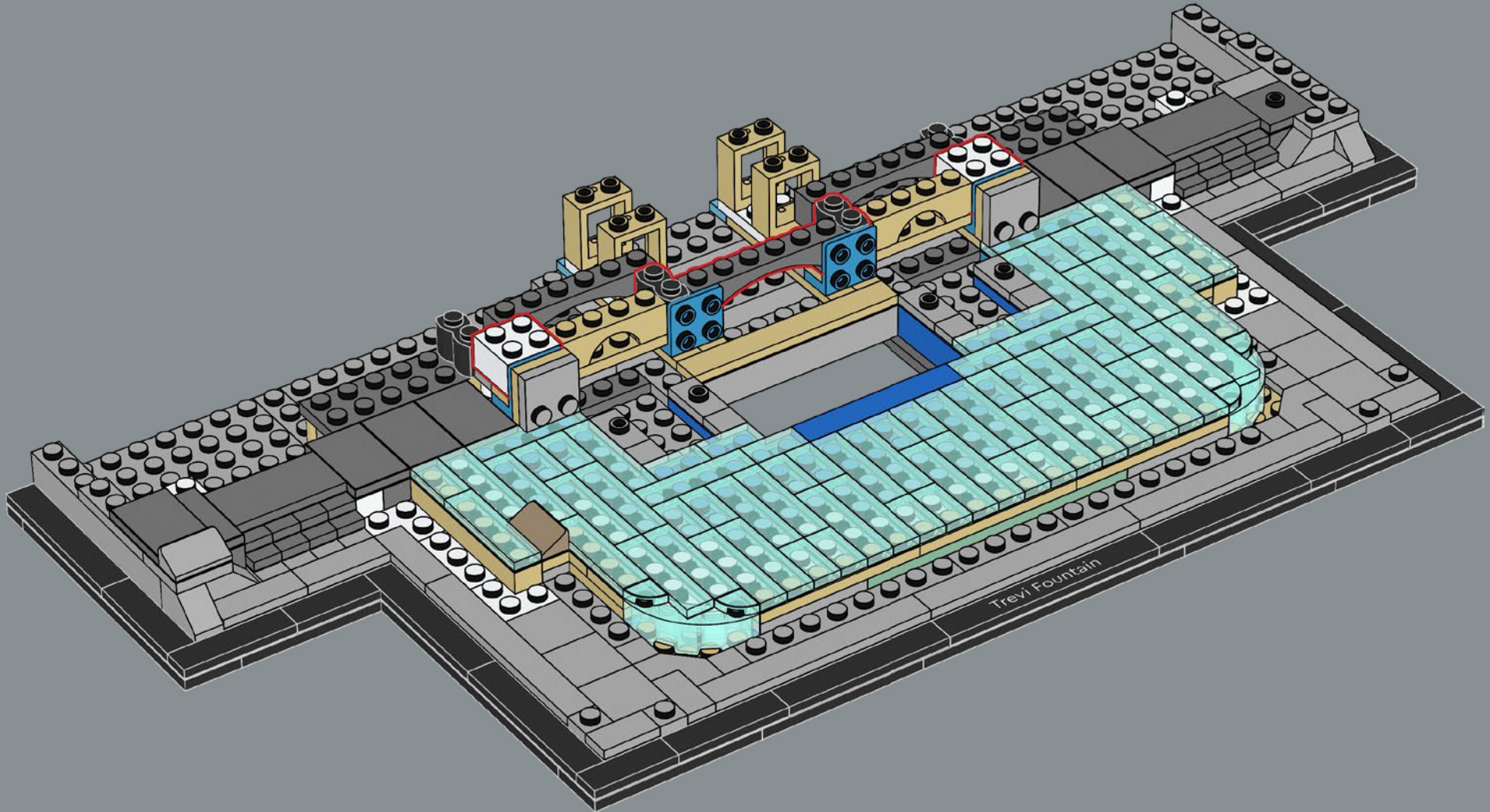

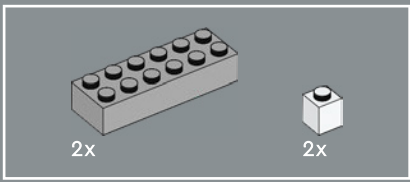

55

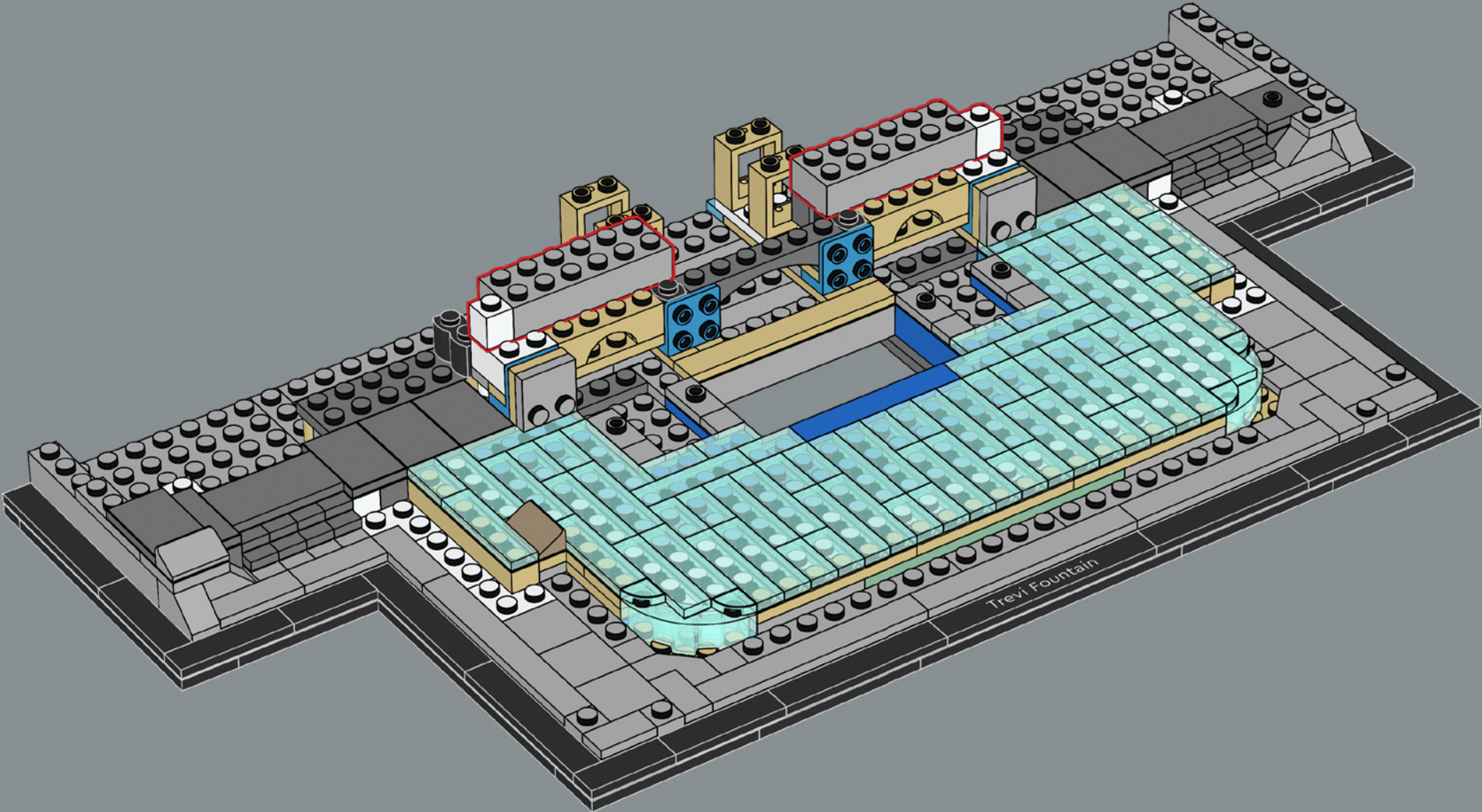

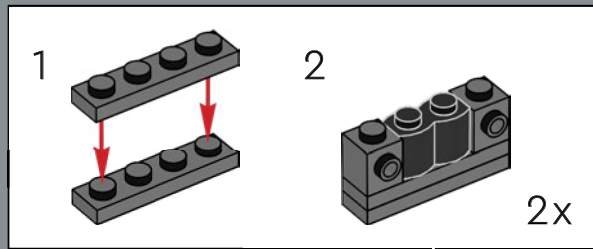
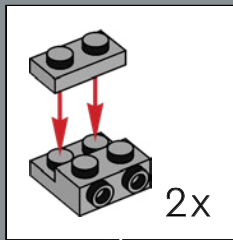
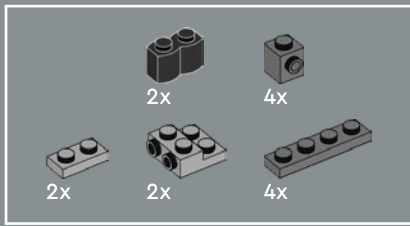

56

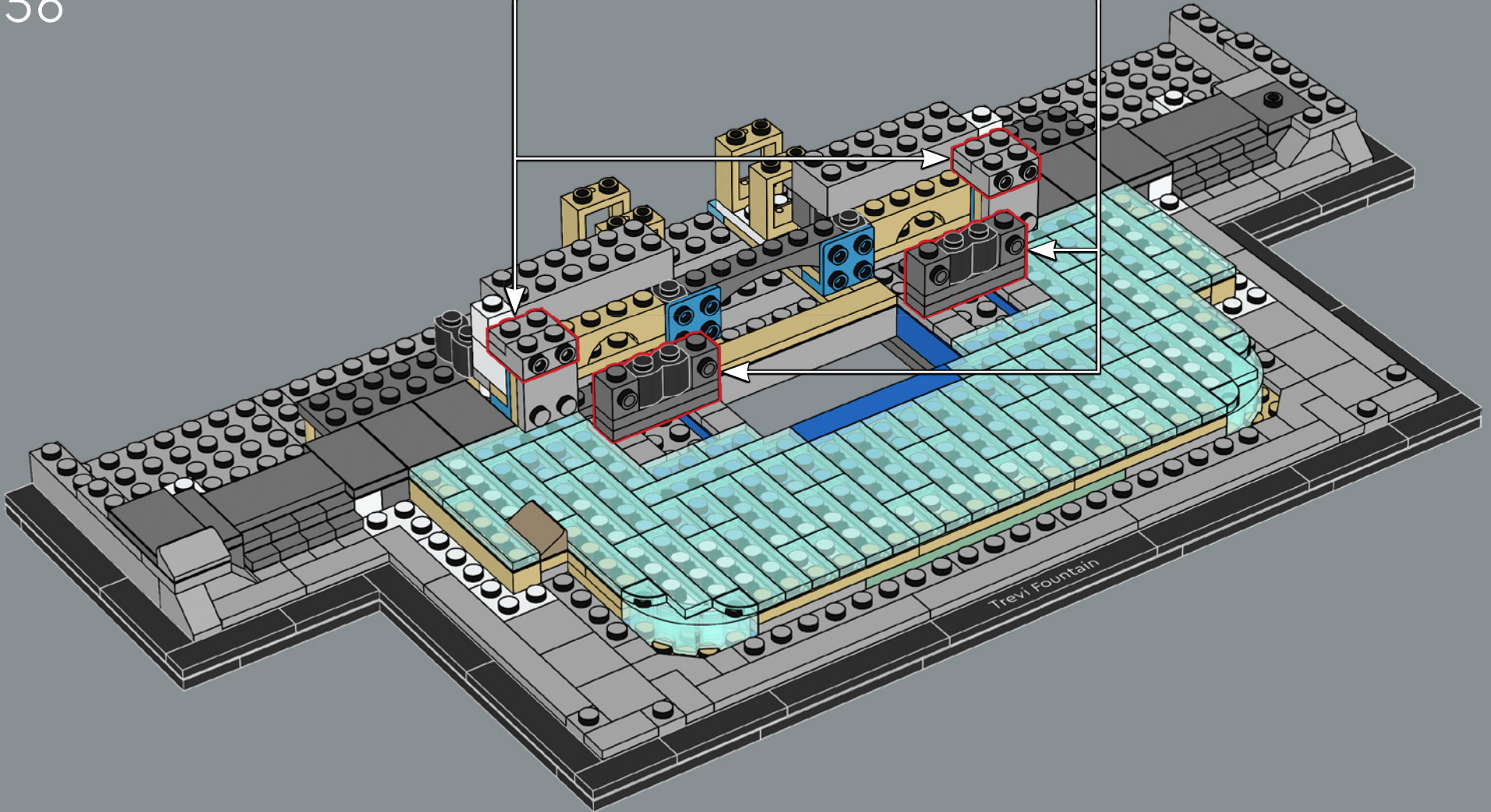

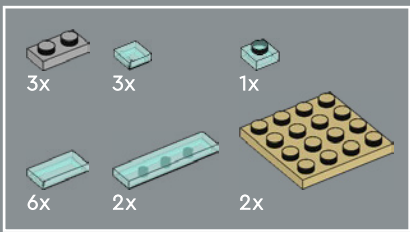

57

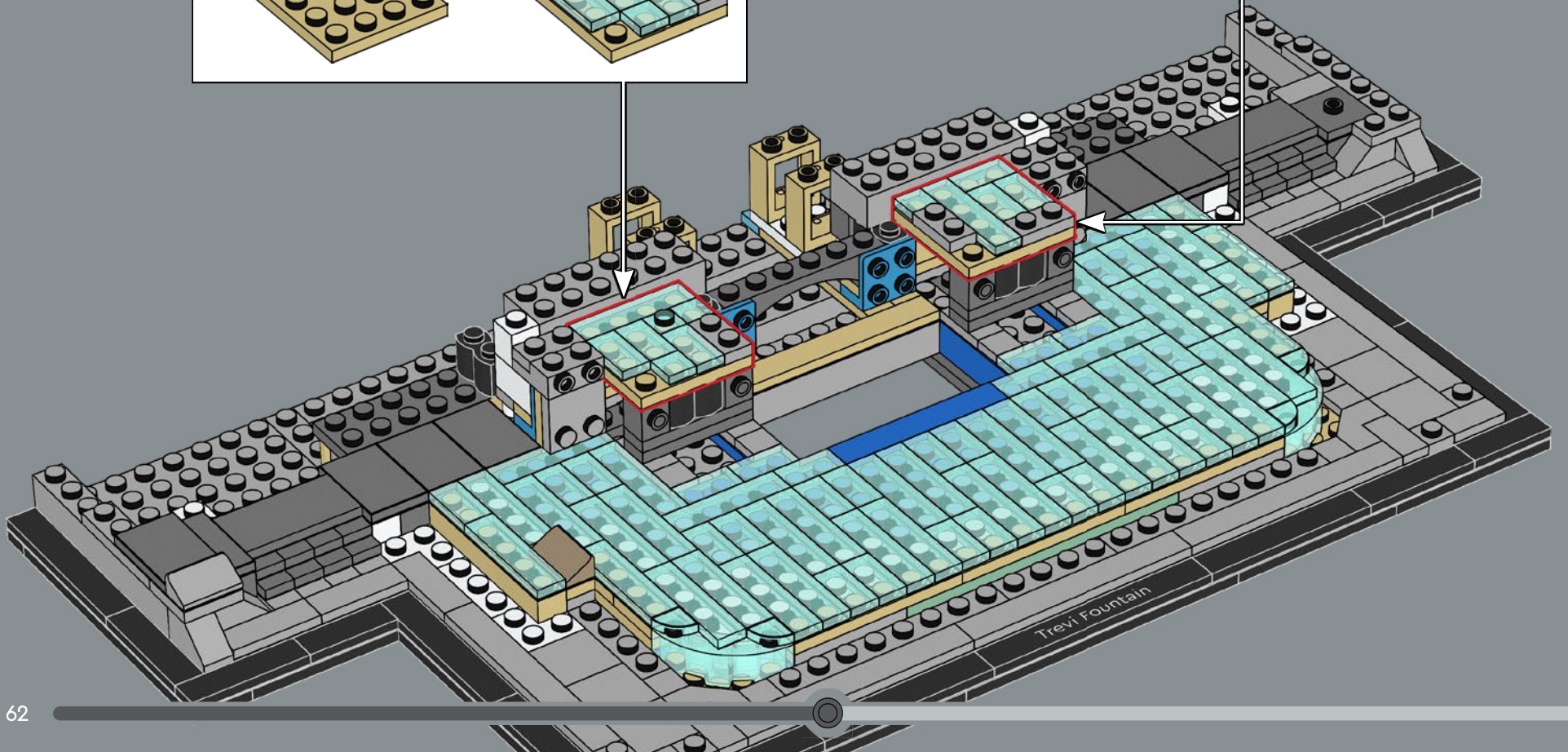
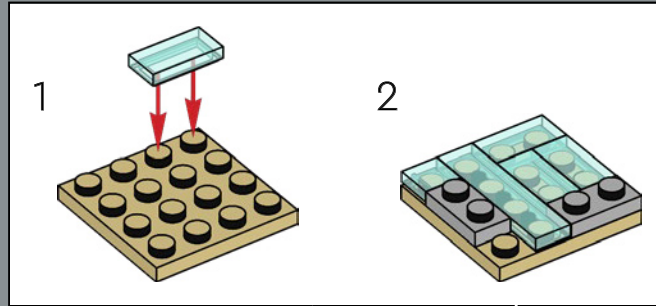
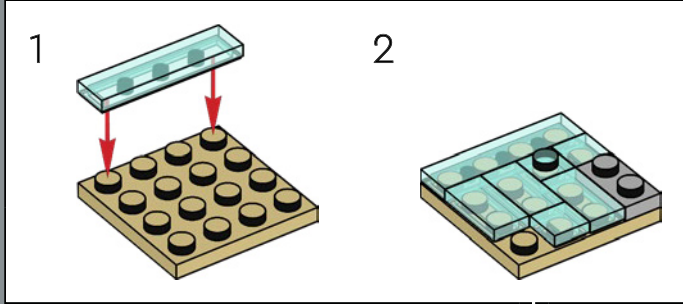

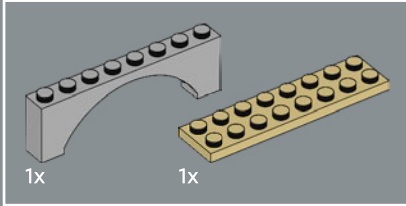
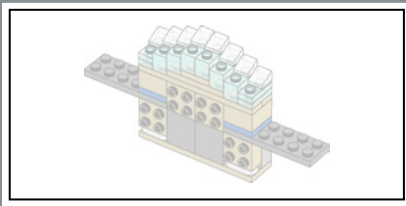

58

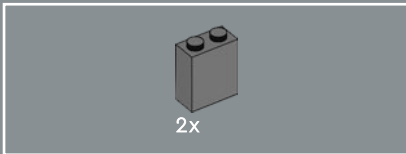
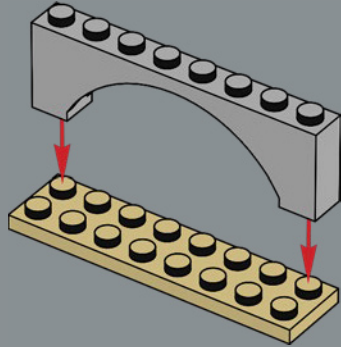

59

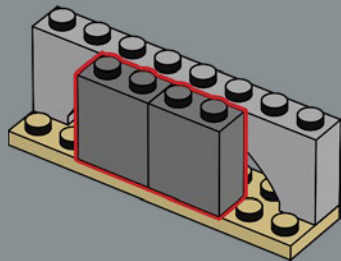

60

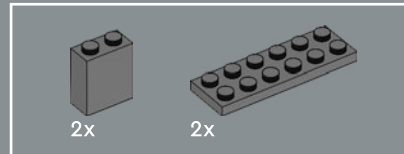
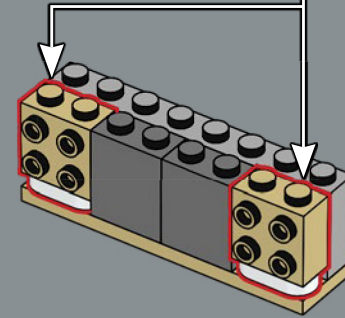
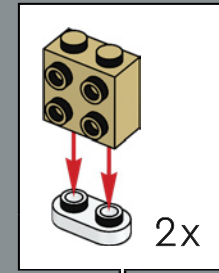

61

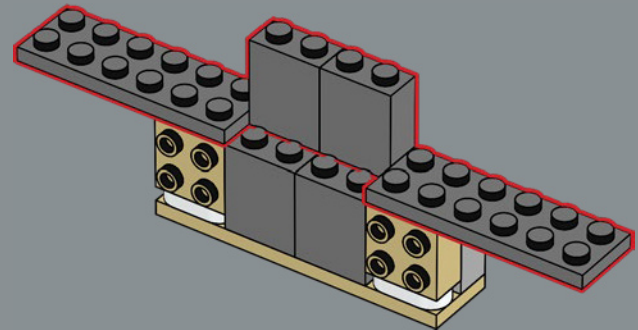

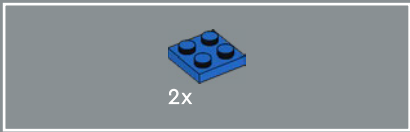

62

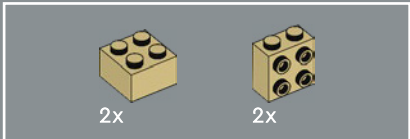
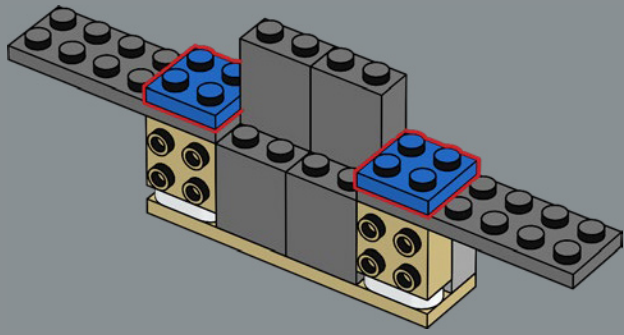

63

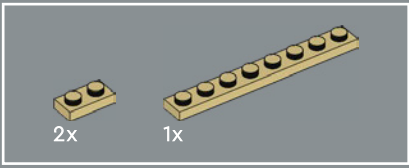
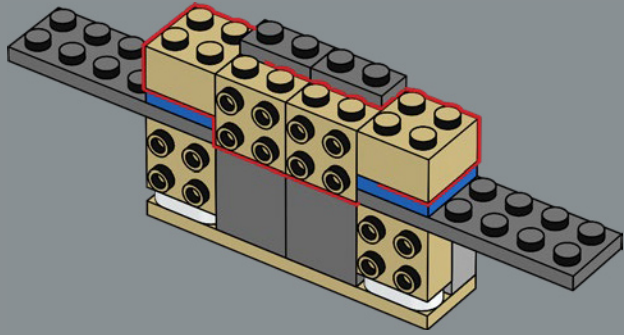

64

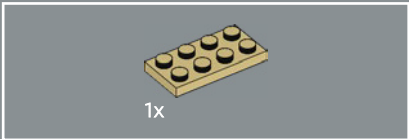
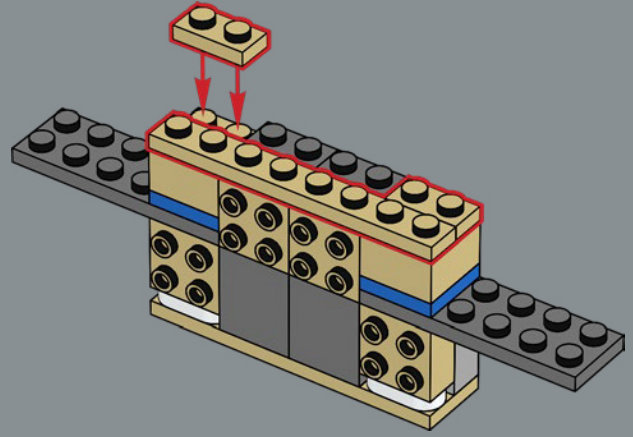

65

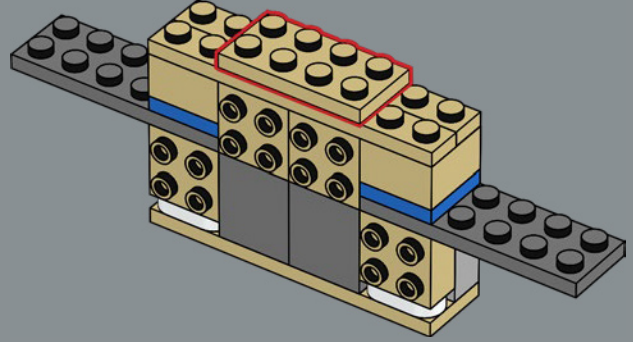



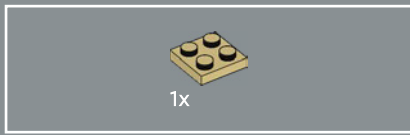

66

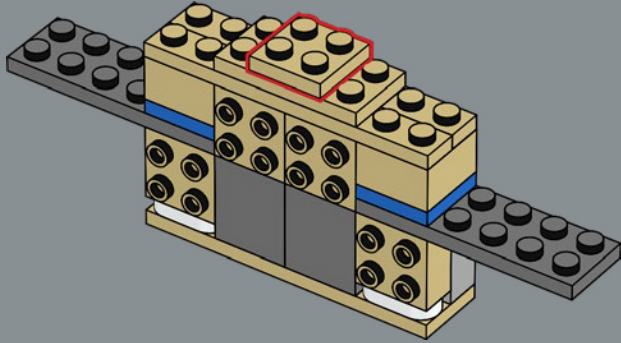

67

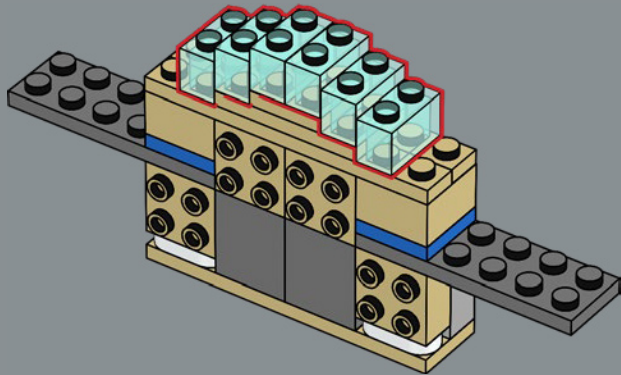

68

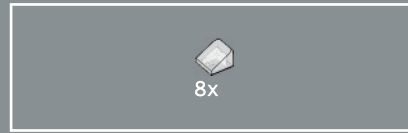
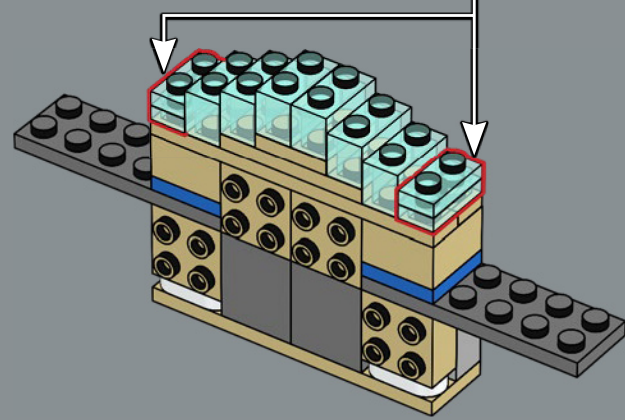
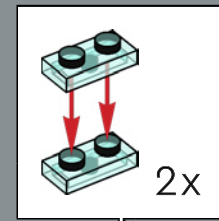

69

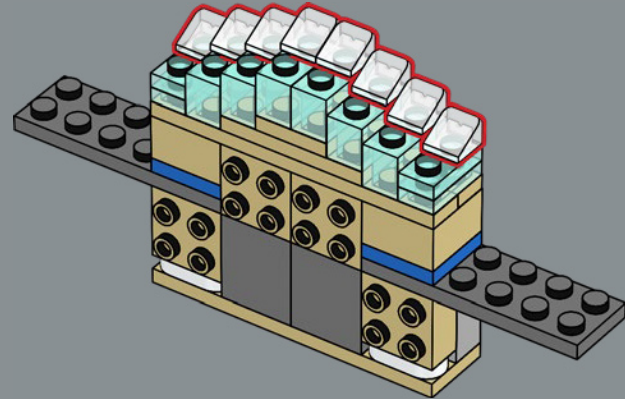

La Fontana di Trevi se construyó en el extremo del antiguo Acqua Vergine, y los acueductos siguen suministrando agua a la fuente hoy en día.

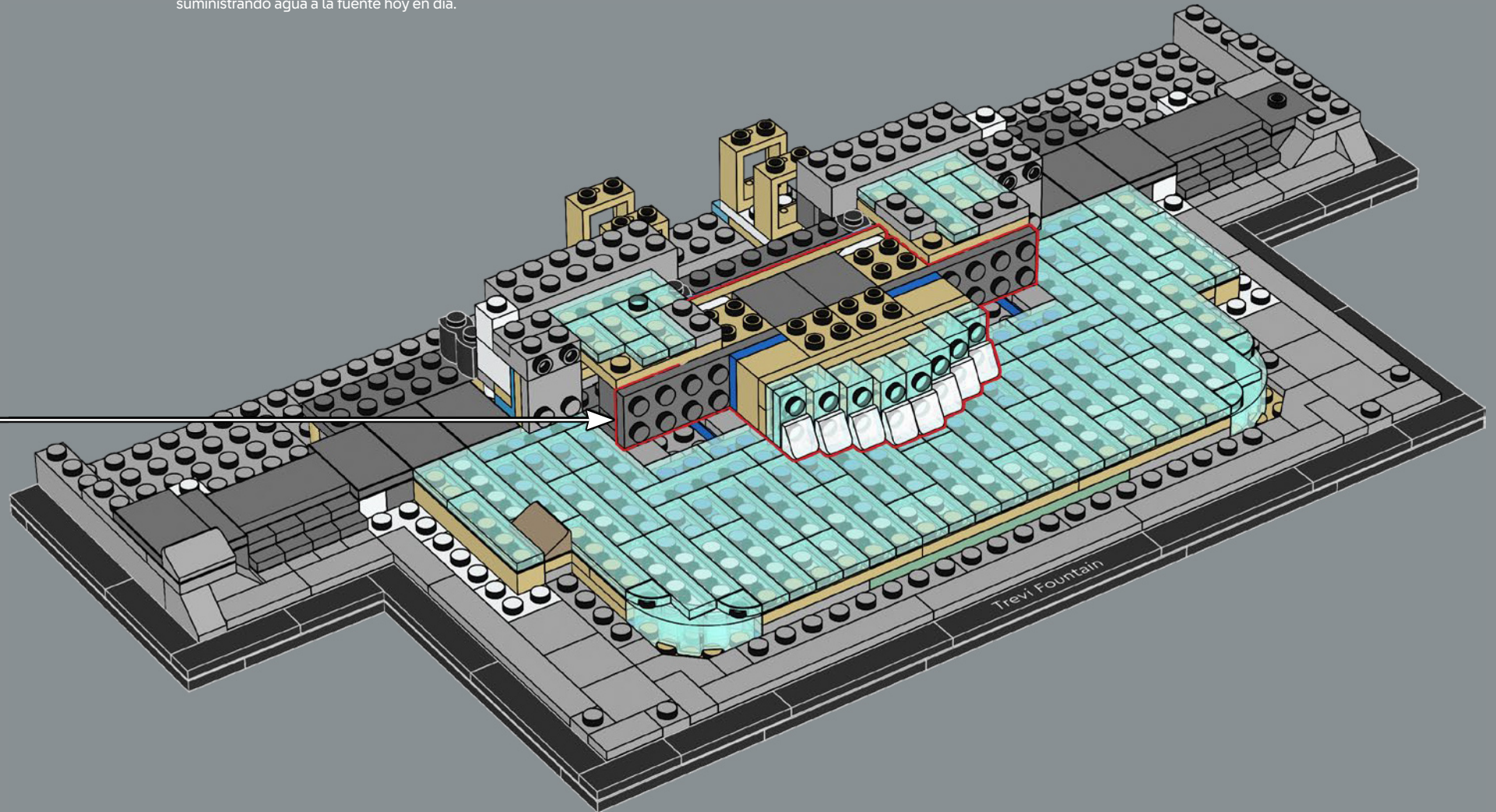

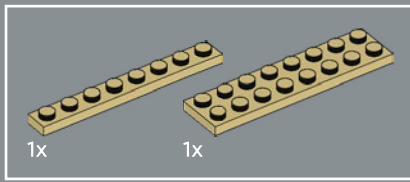

71

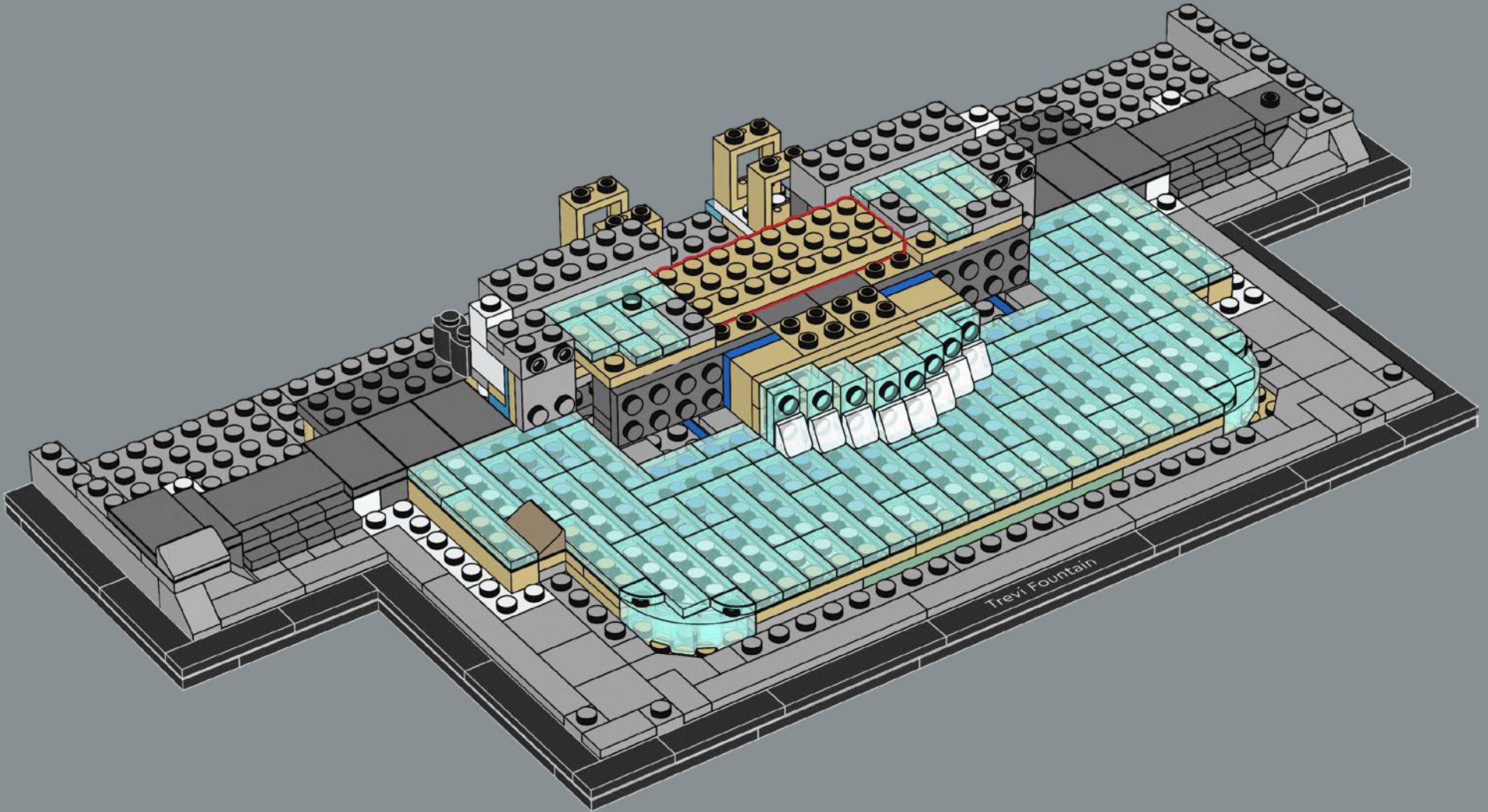

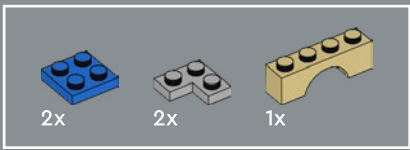

72

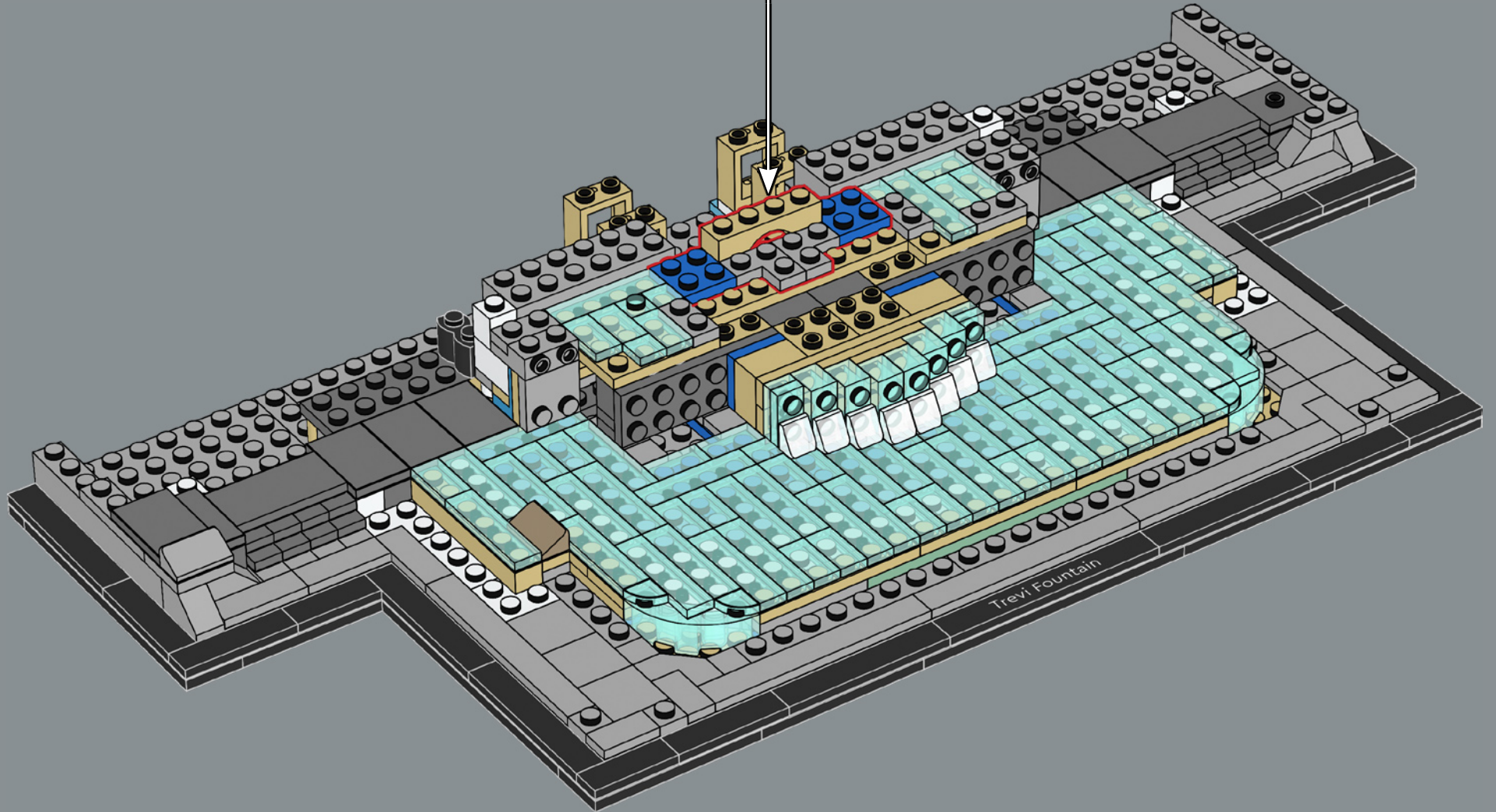
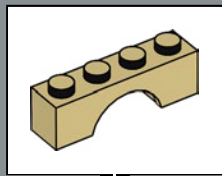

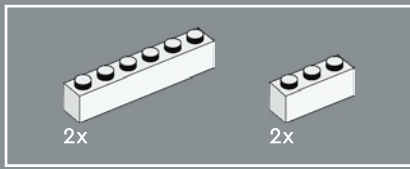

73

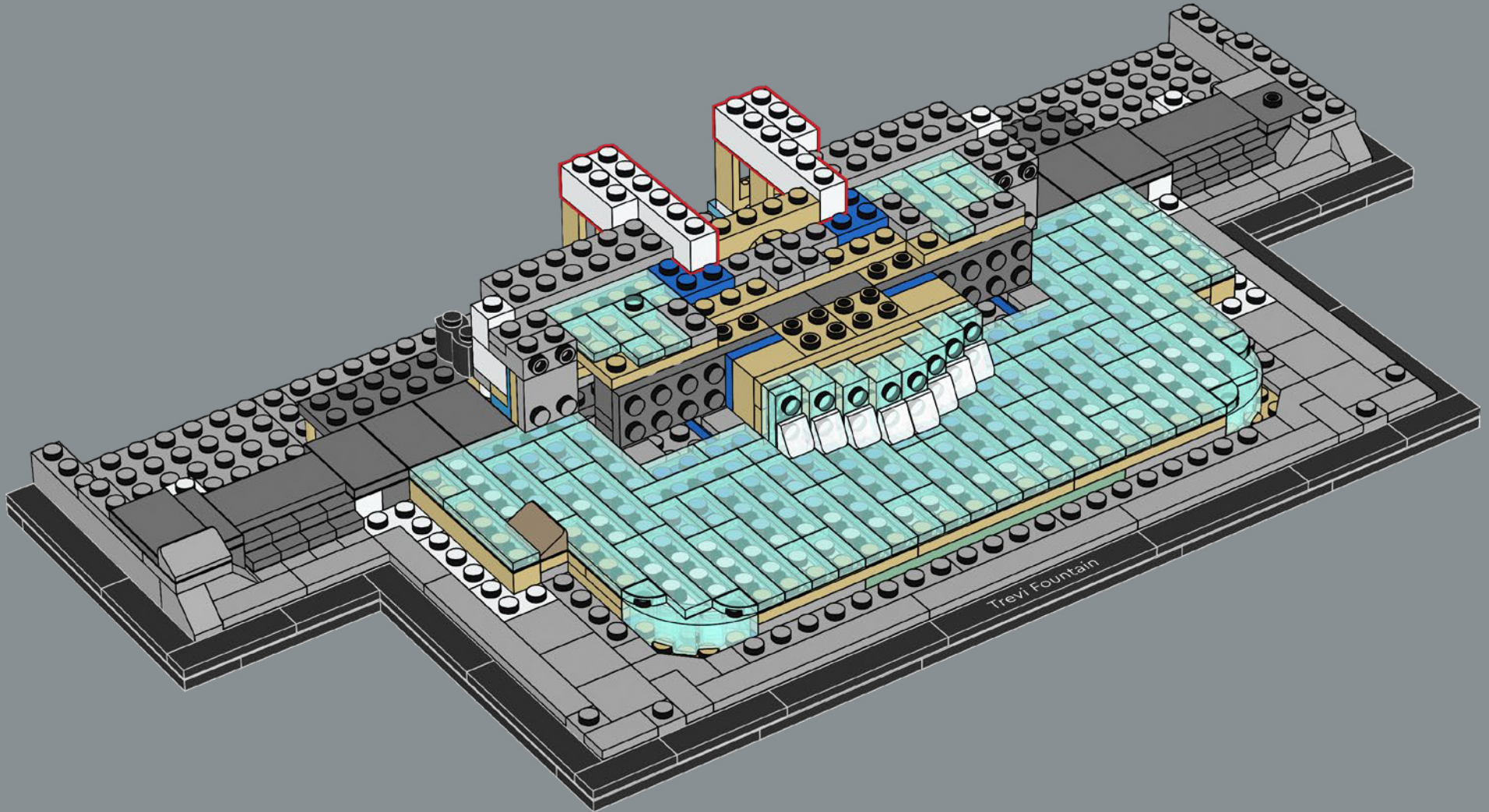

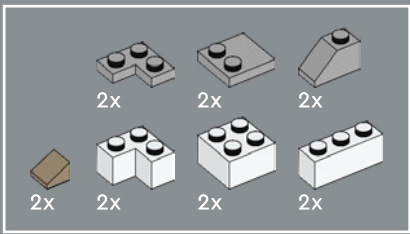

74

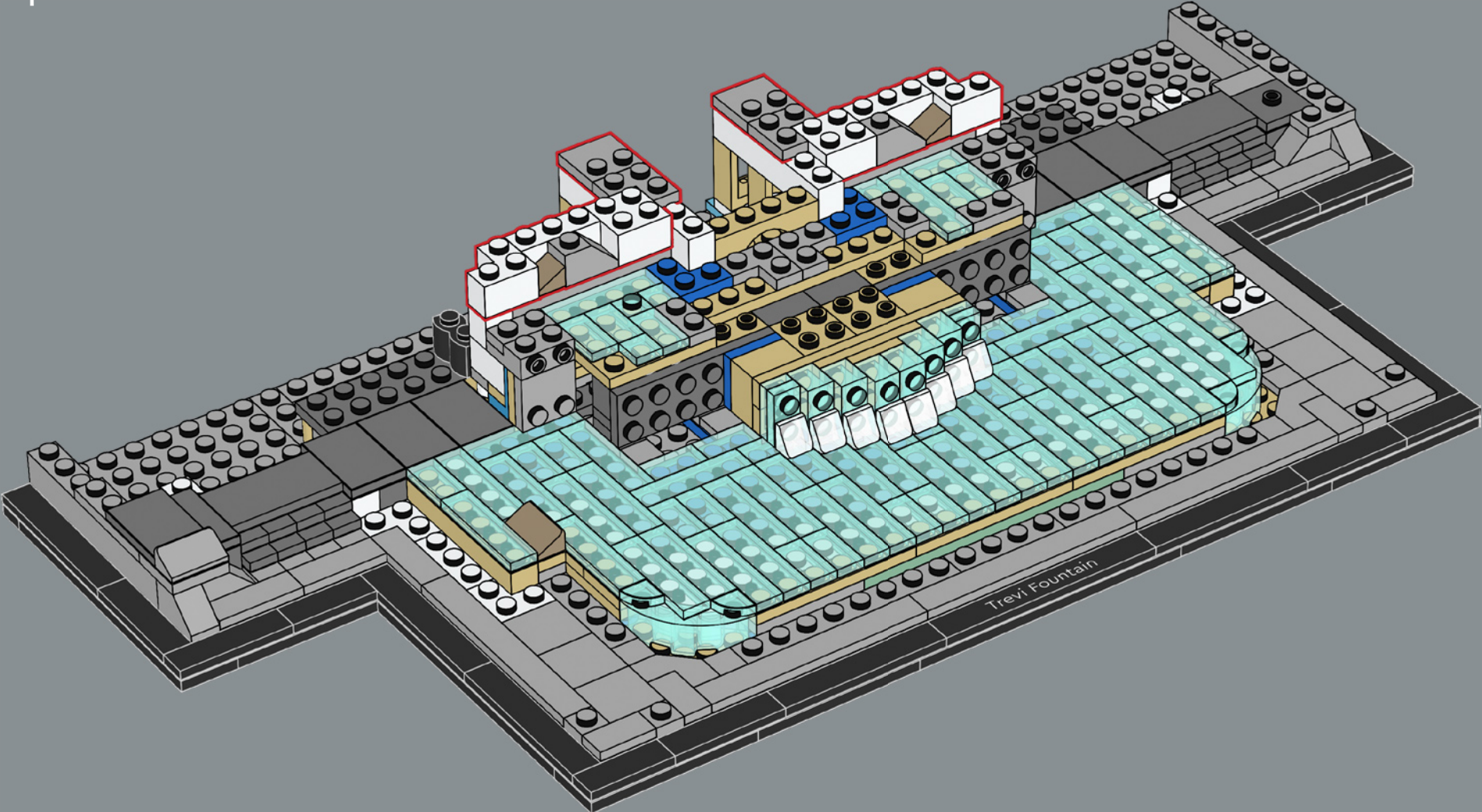

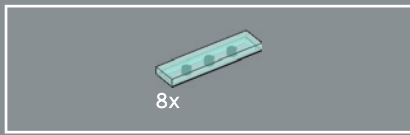

75

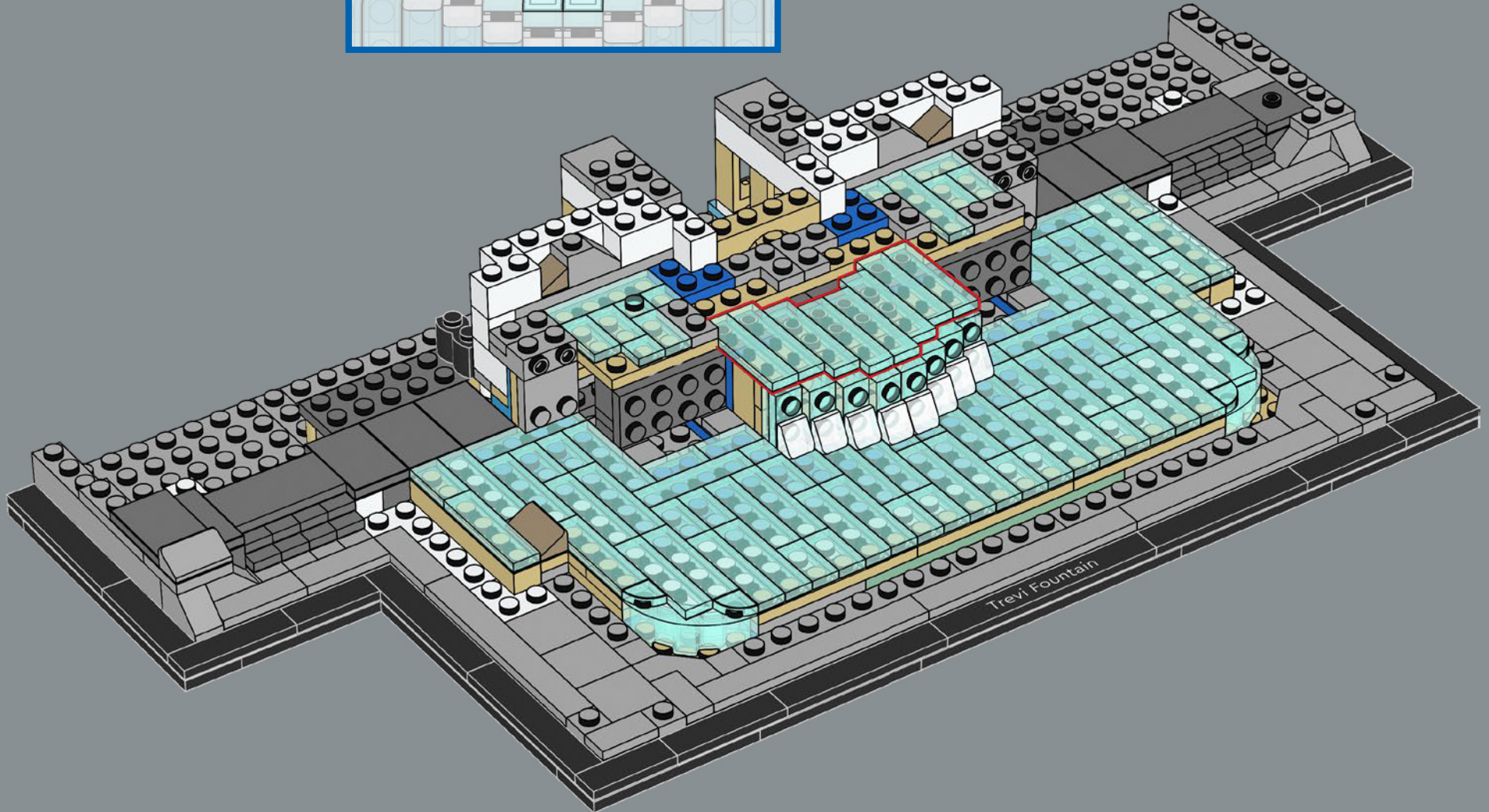
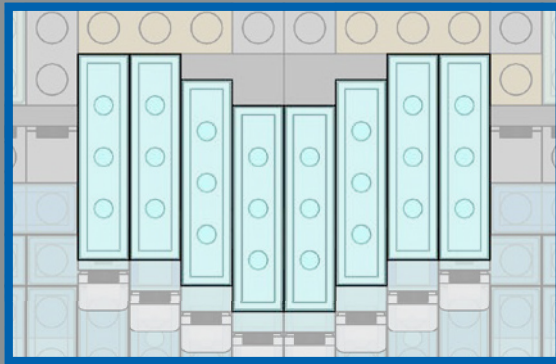

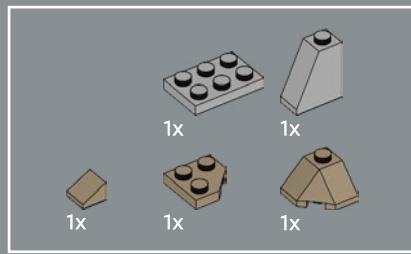

76

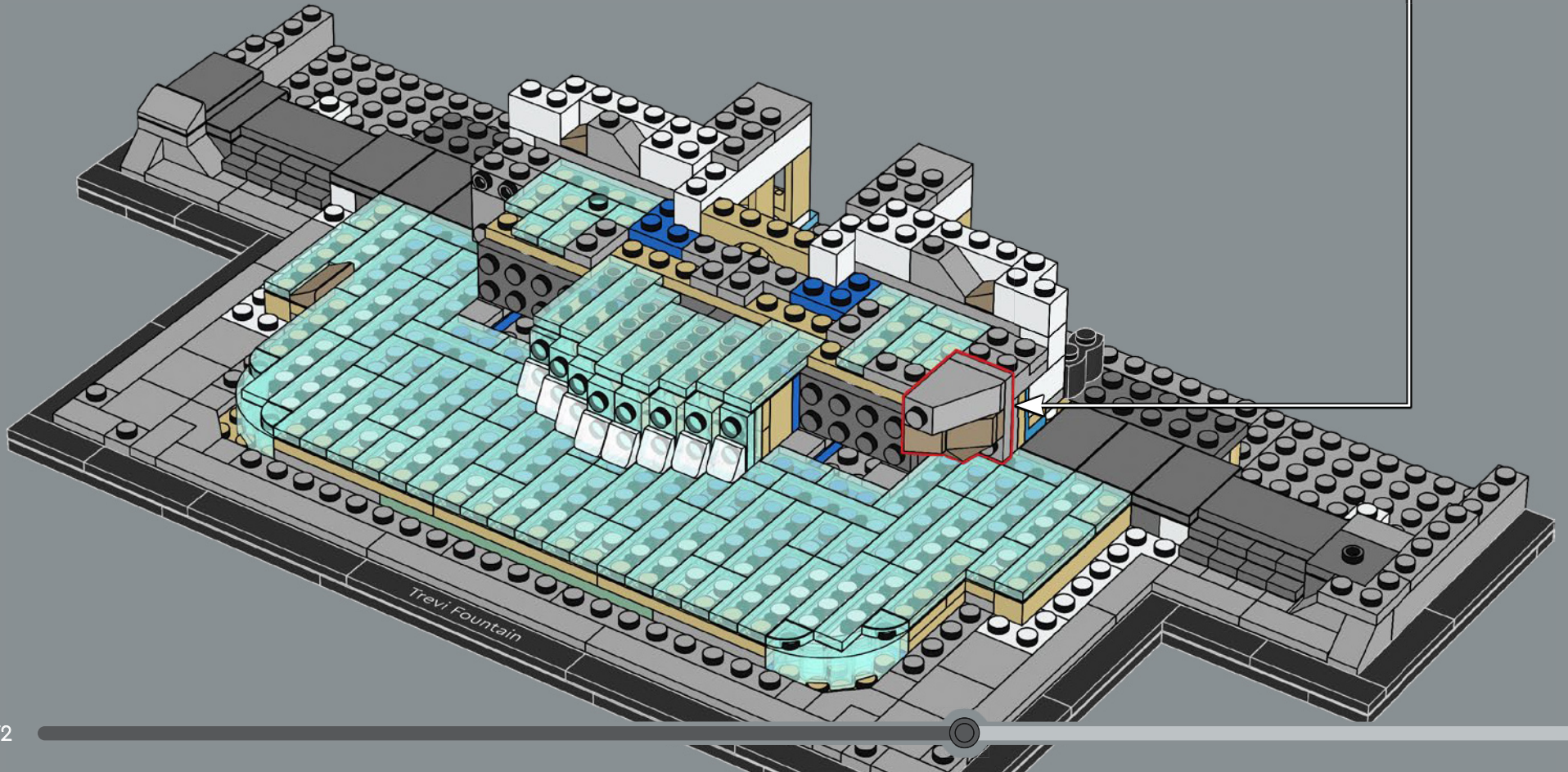
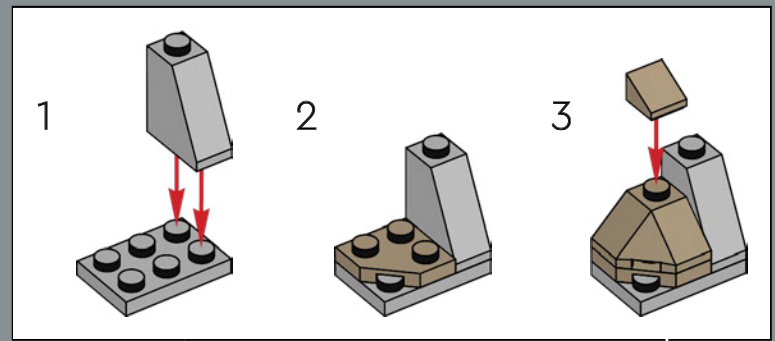



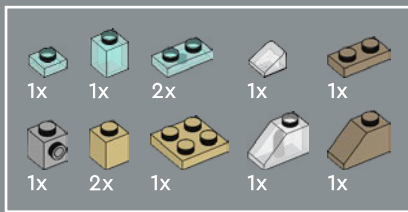

77

1

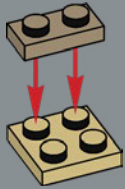

2

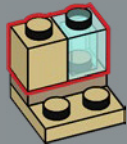

3

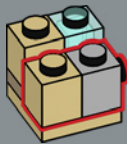

4



5



6

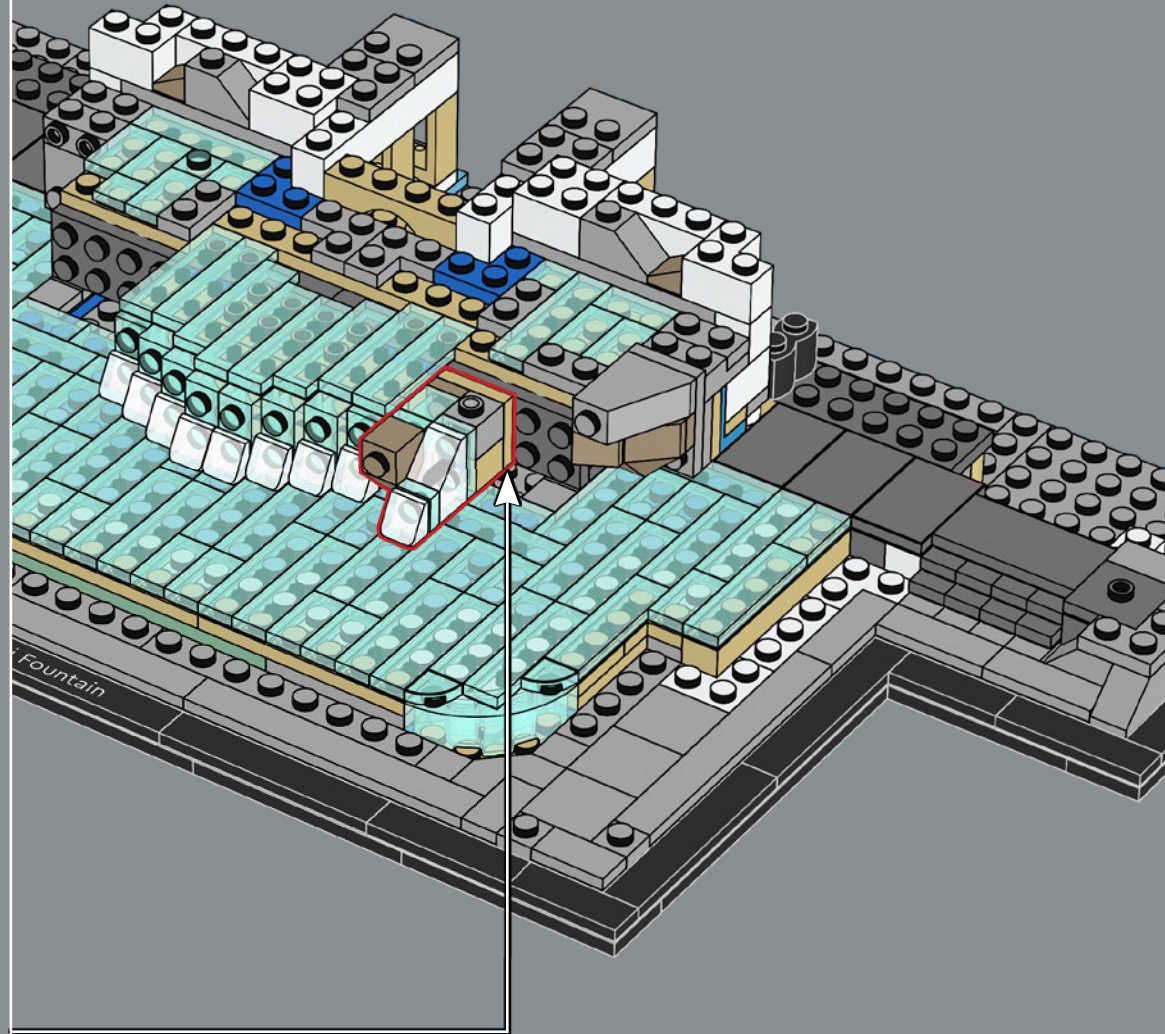

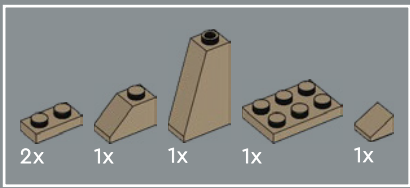

78

1

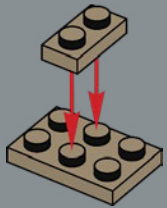

2

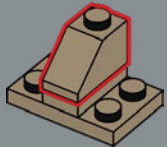

3

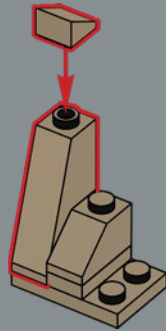

4

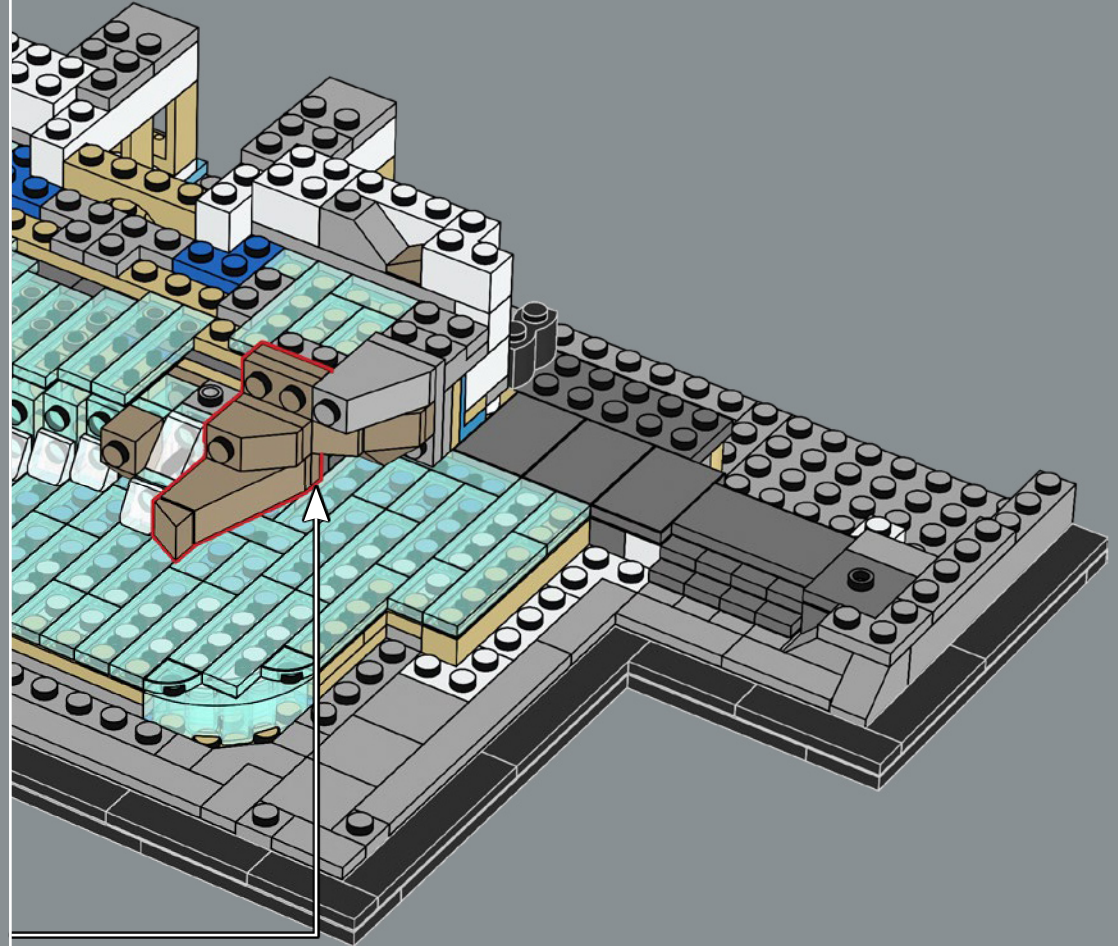
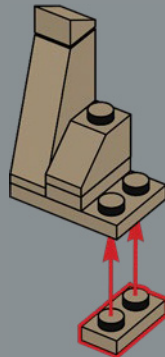

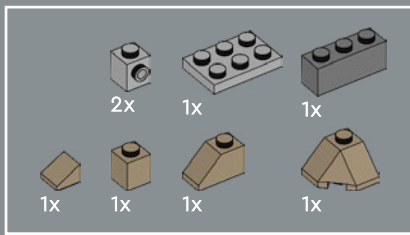

79

1

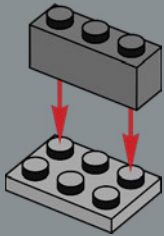

2

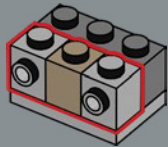

3

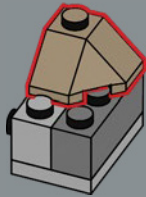

4

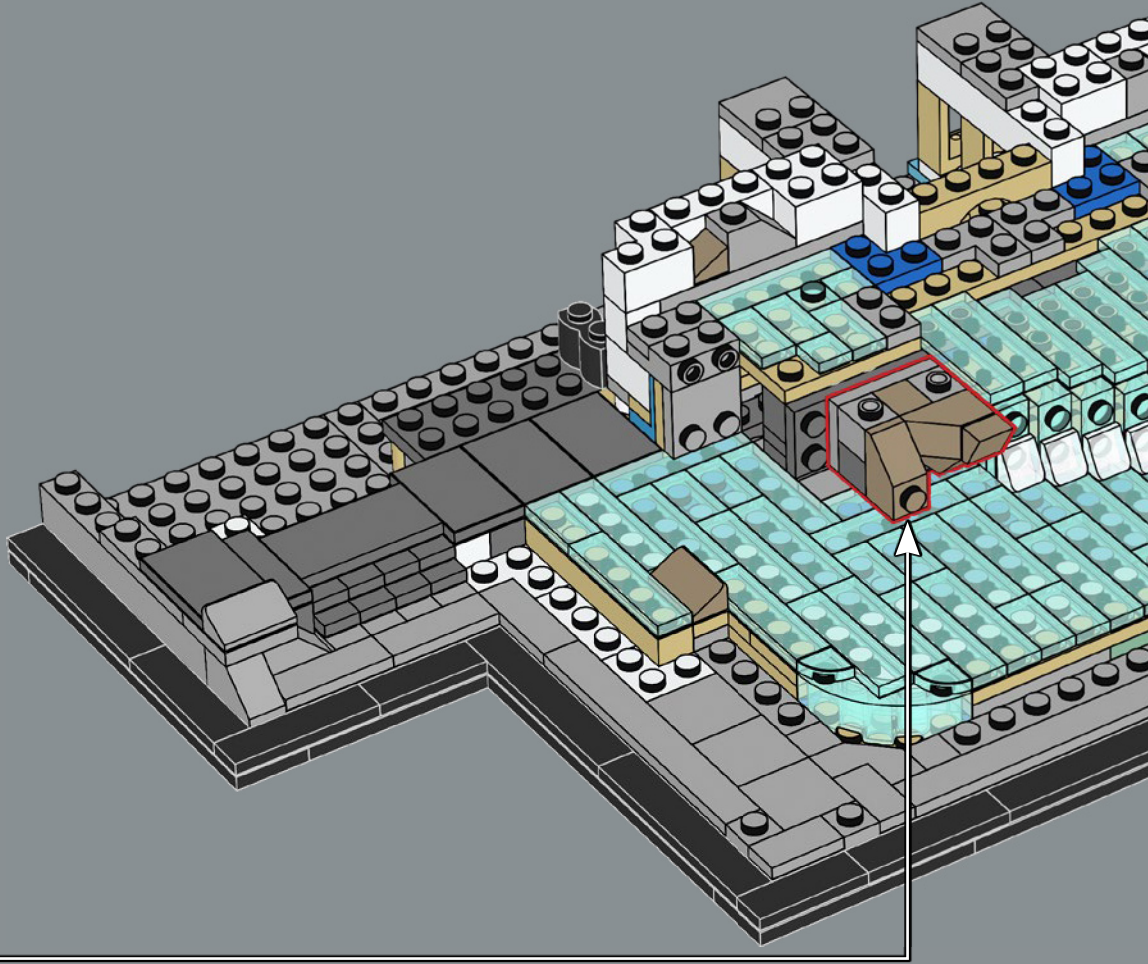
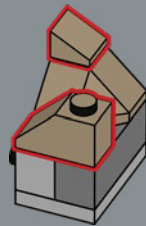

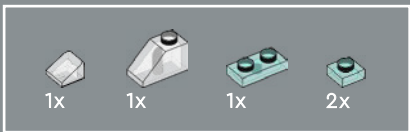

80

1

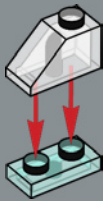

2

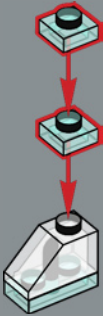

3

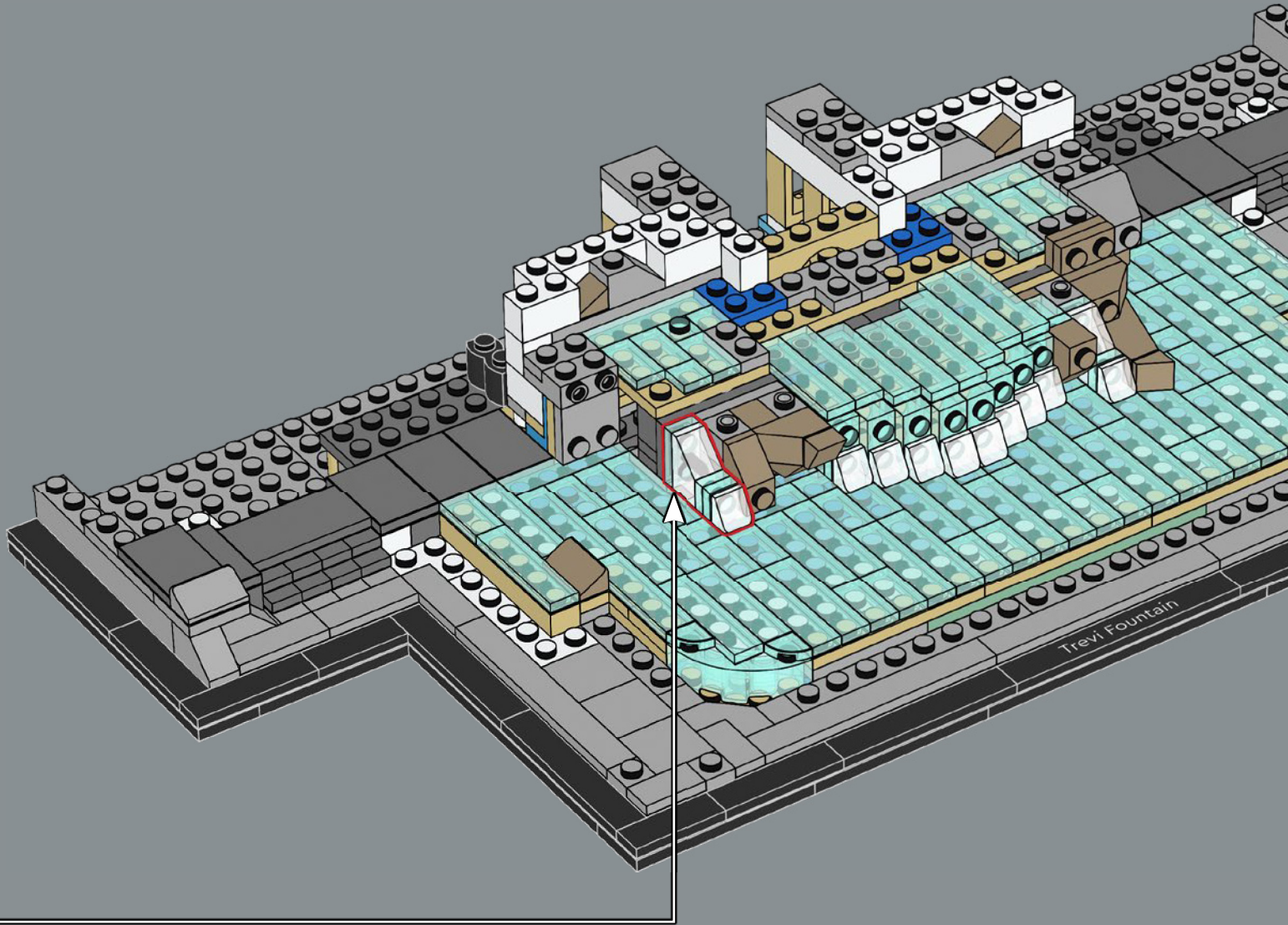

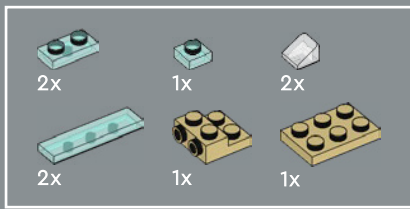

81

1

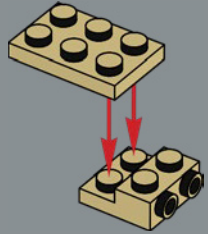

2

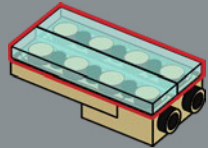

3

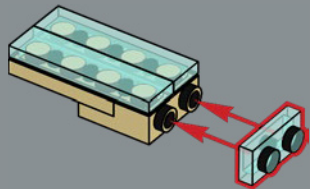

4

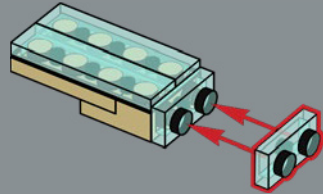

5

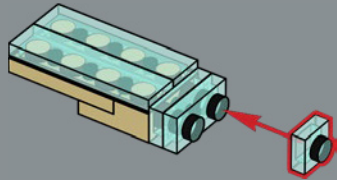

6

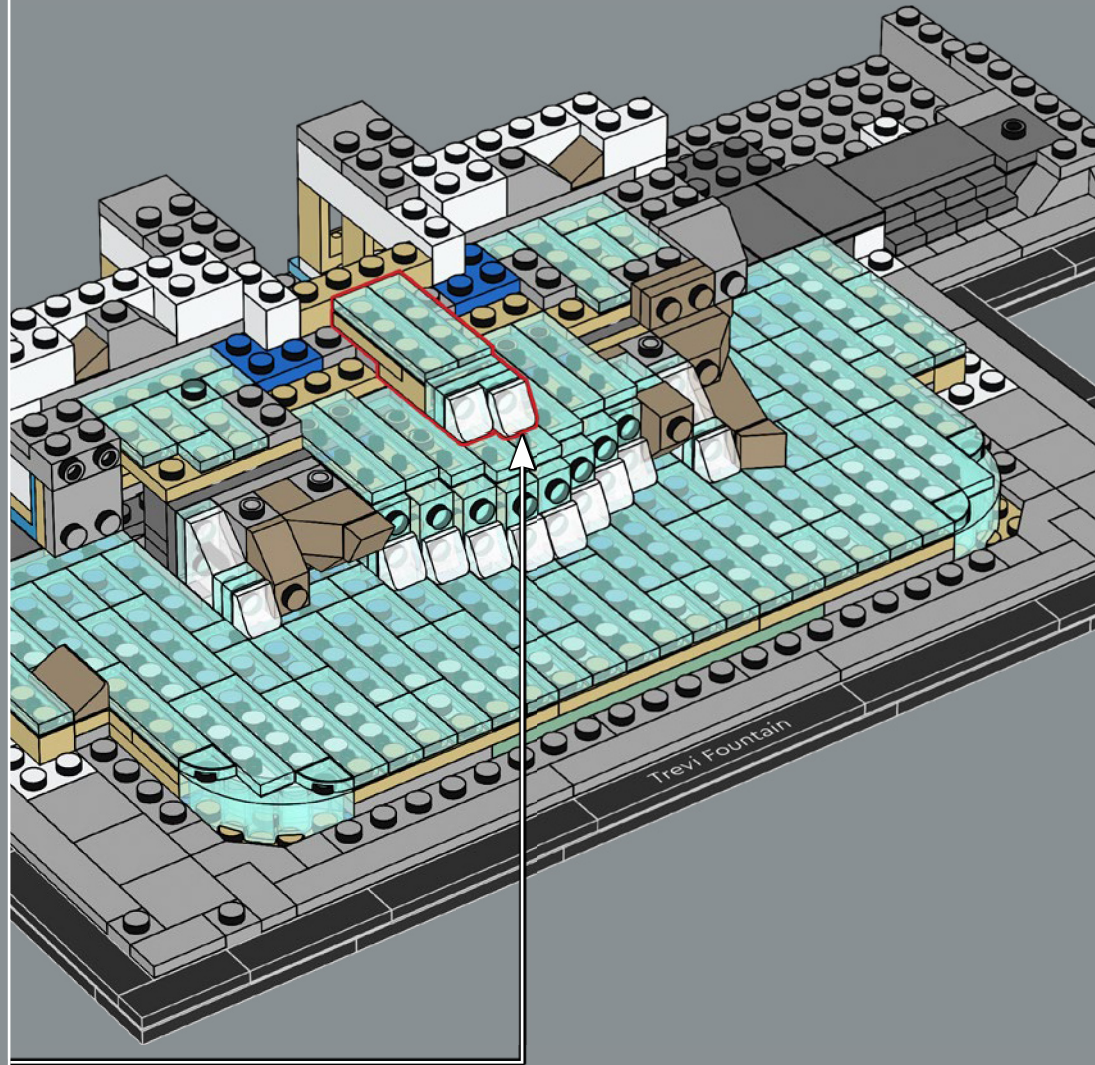
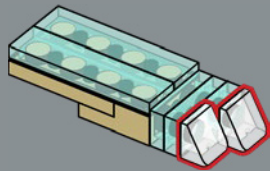

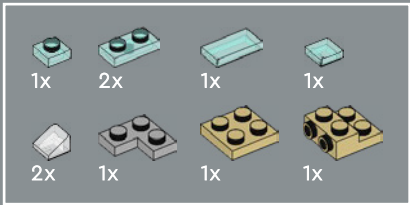

82

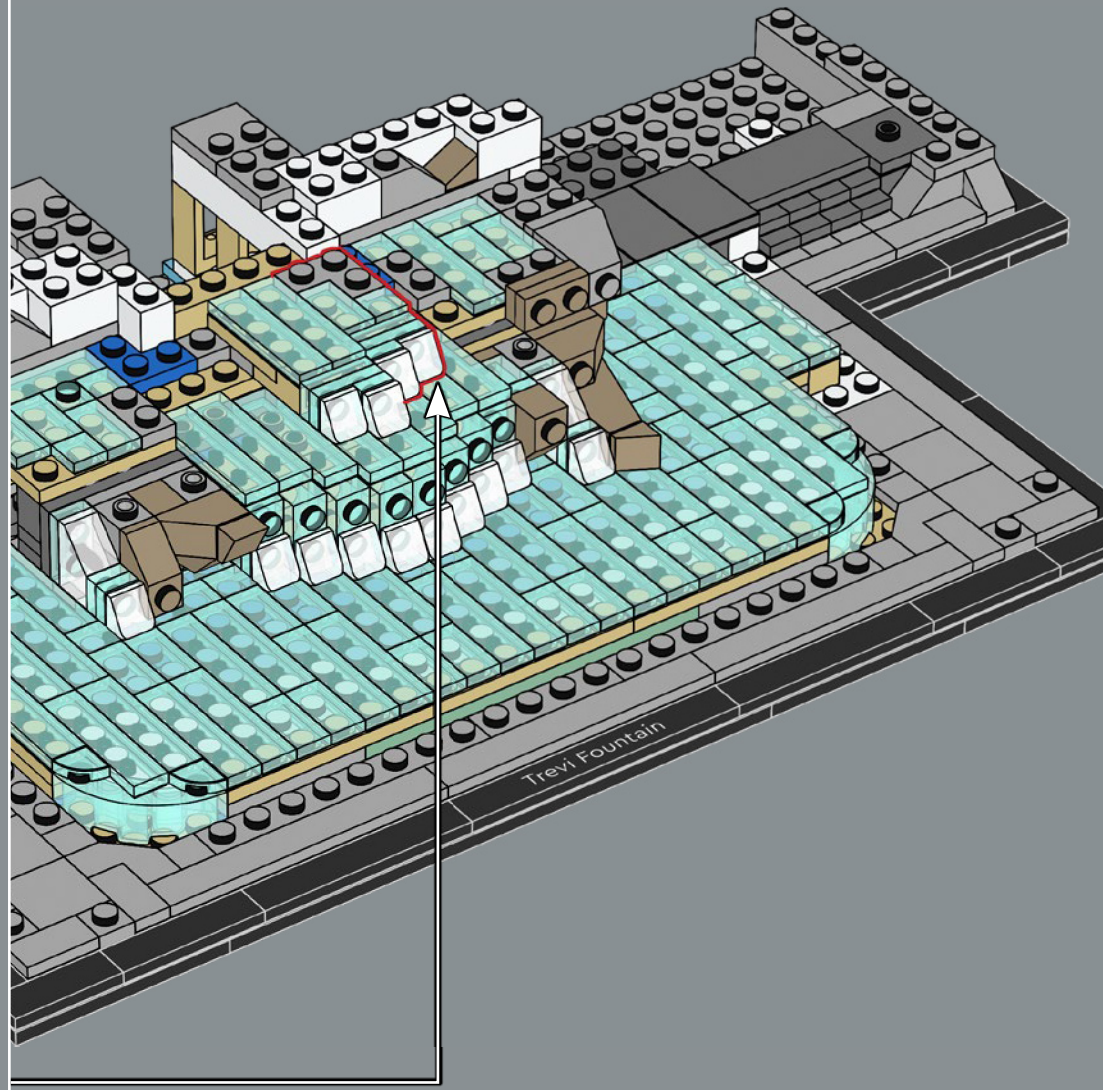
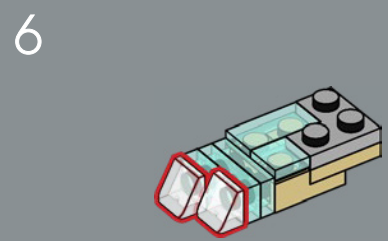
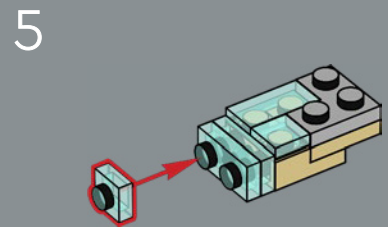
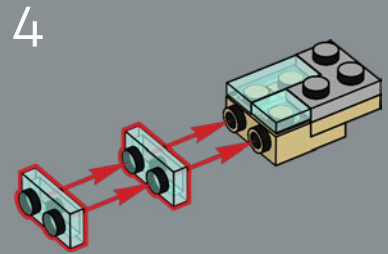
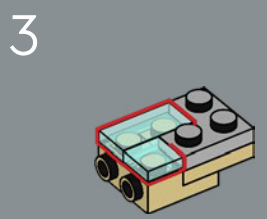
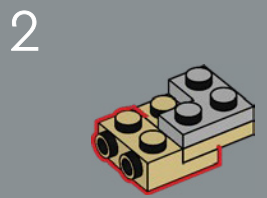
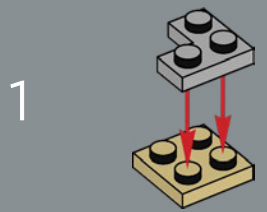

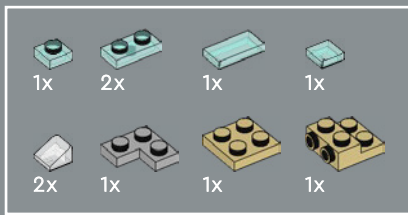

83

1

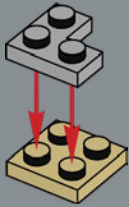

2

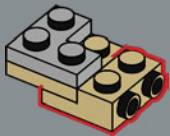

3

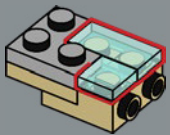

4

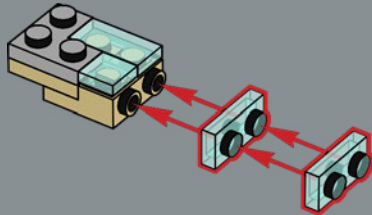

5

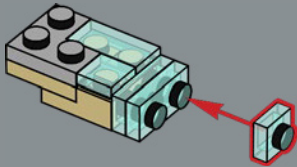

6

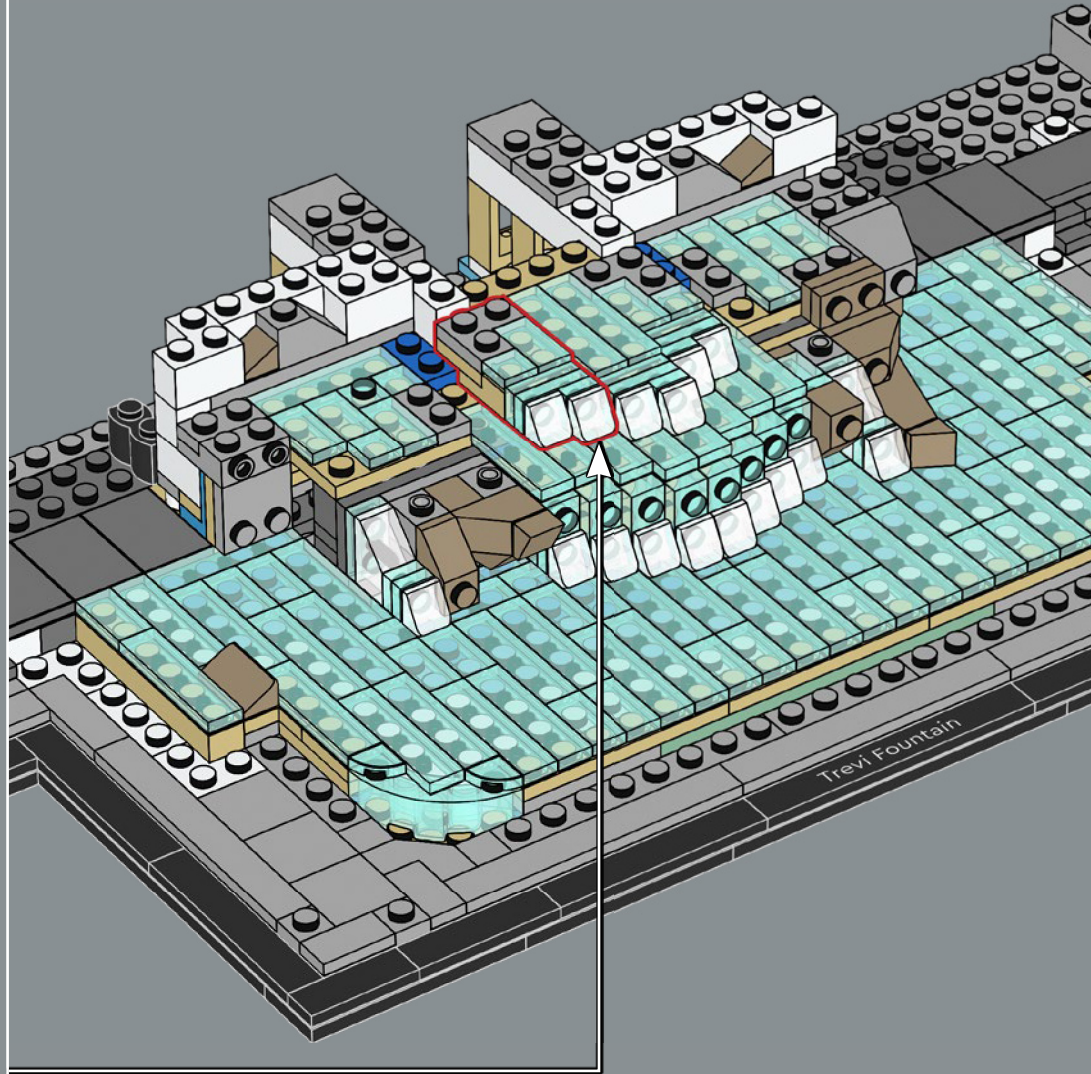
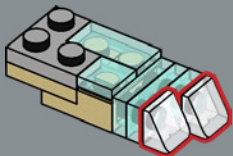

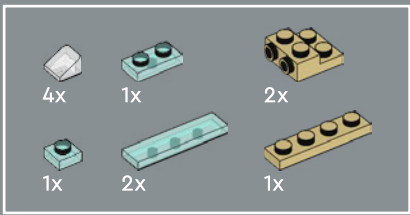

# 84

1

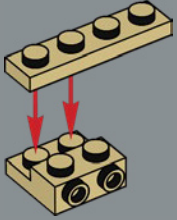

2

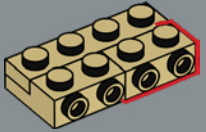

3

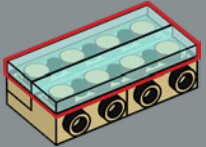

4

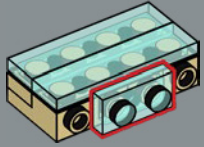

5

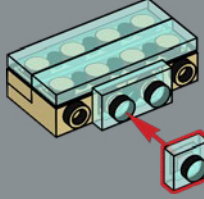

6

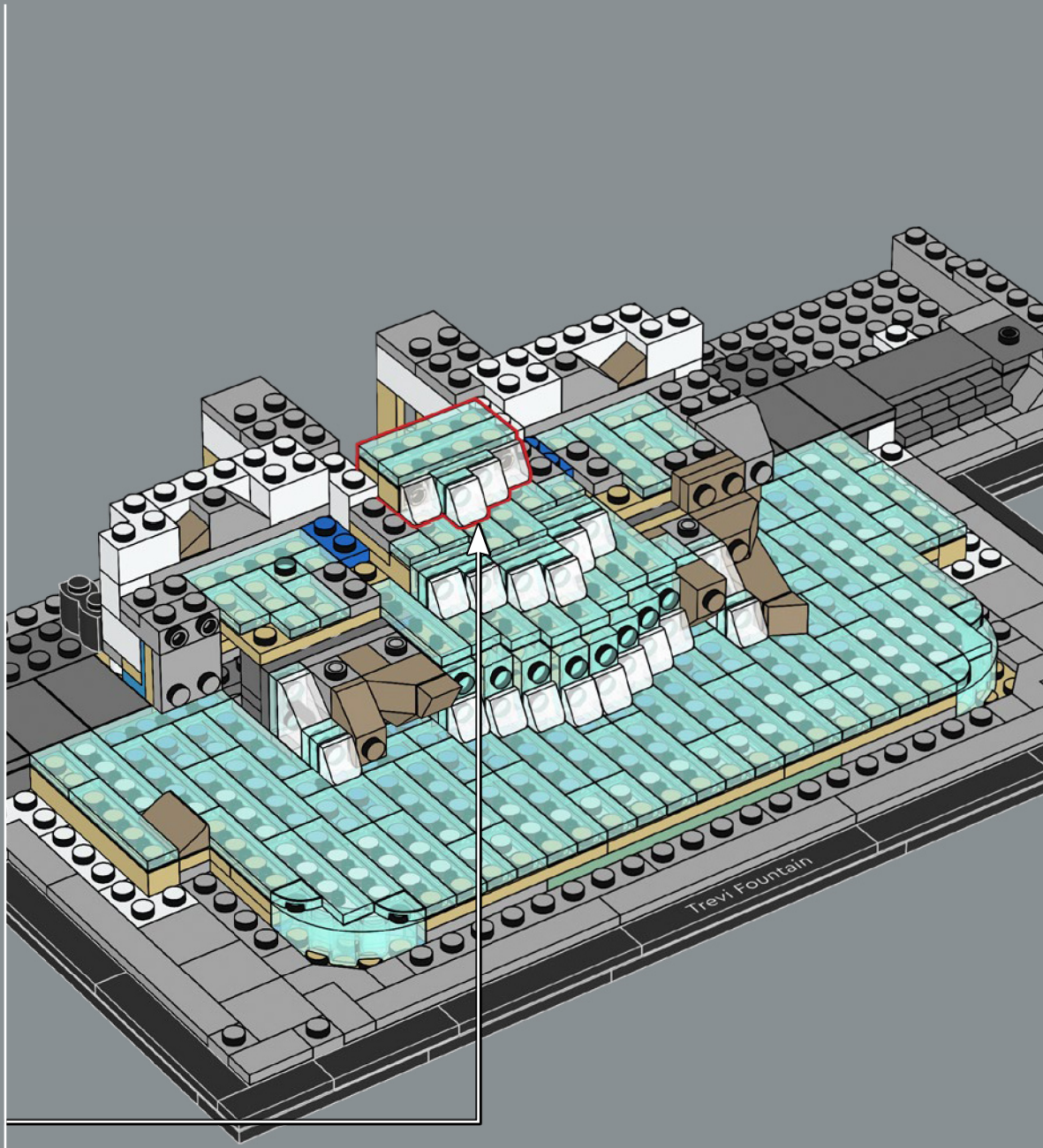
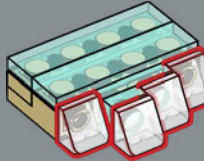





El color bajo el azul transparente refleja el de la vida real. En las secciones superiores, la fina capa de agua que fluye sobre la roca expone su color pétreo, pero, debajo, en la cuenca, la profundidad se indica con tonos de azul más oscuros.

85

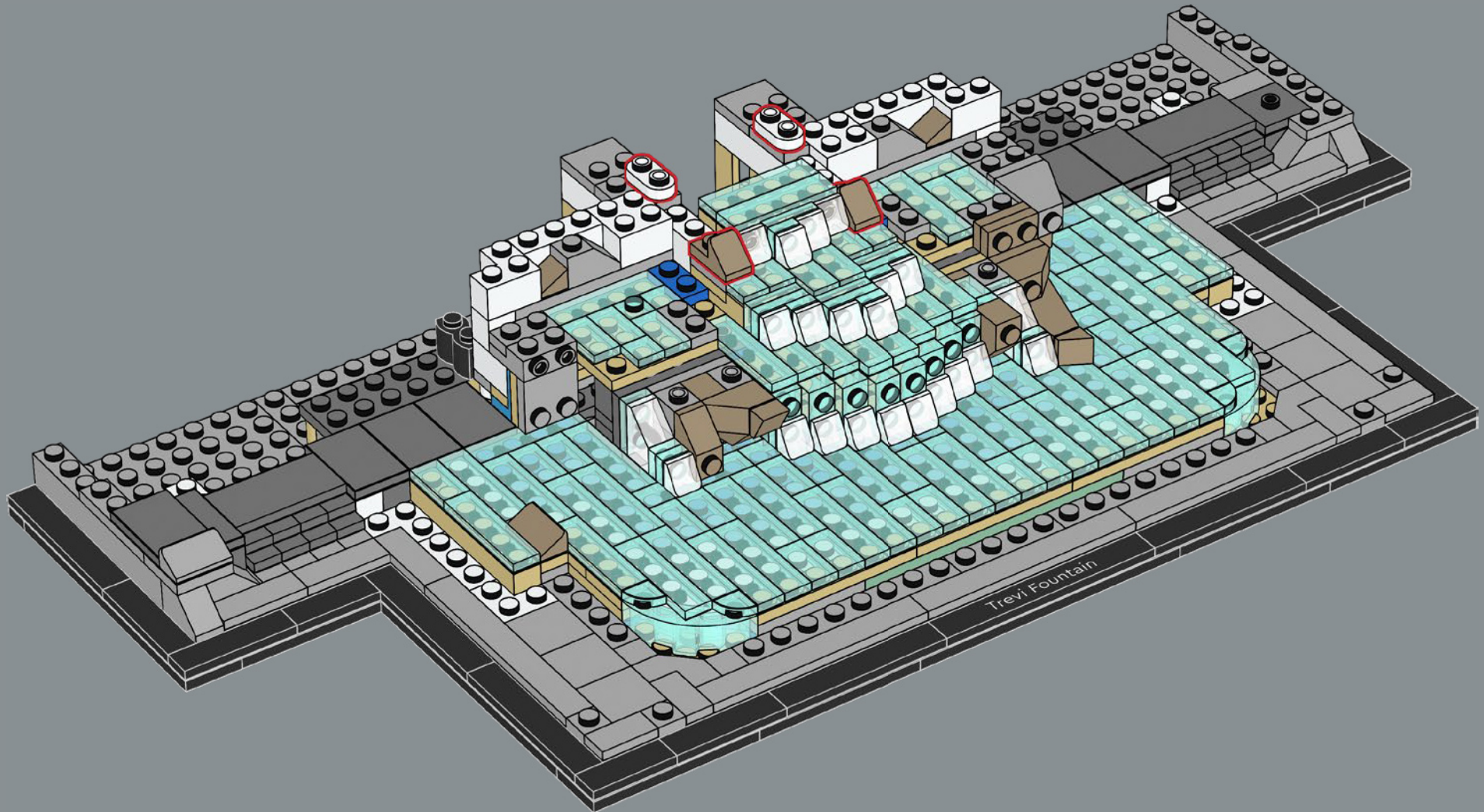

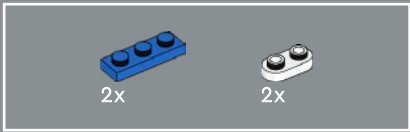

86

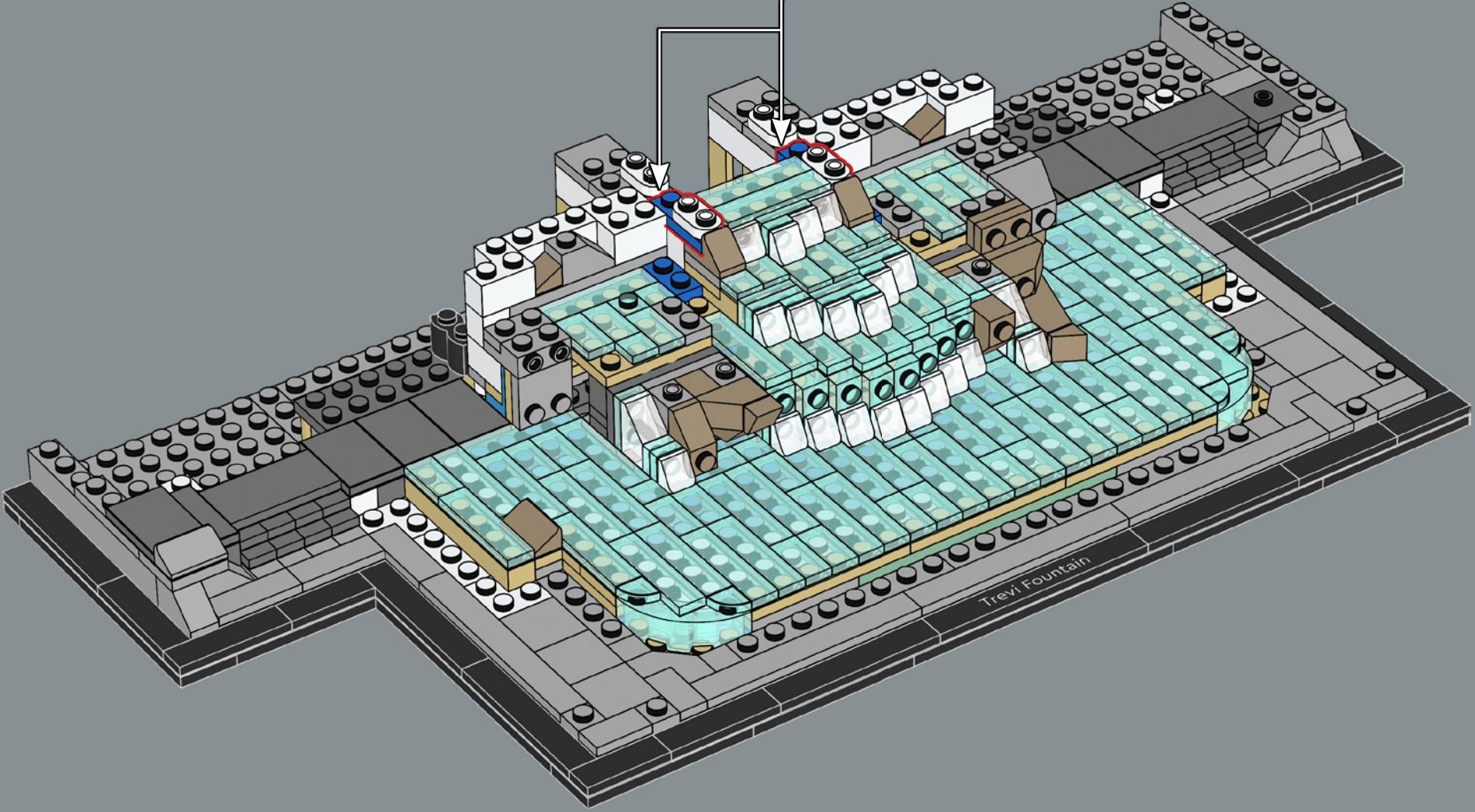
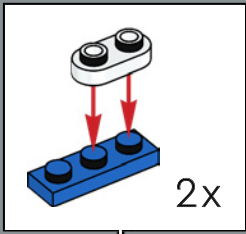

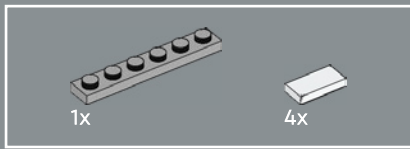

87

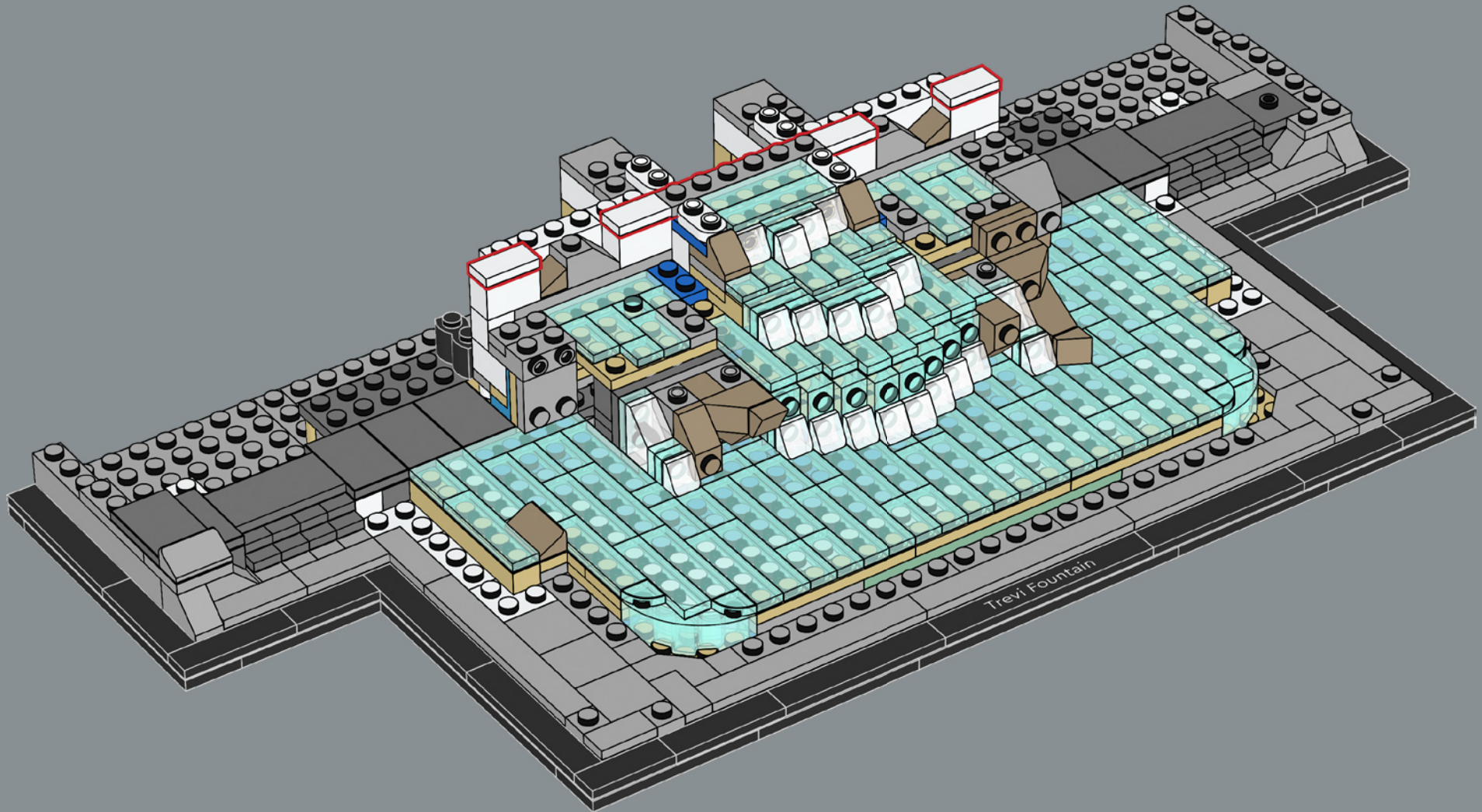

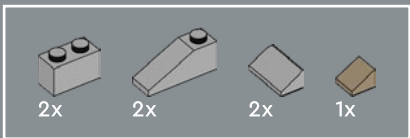

88

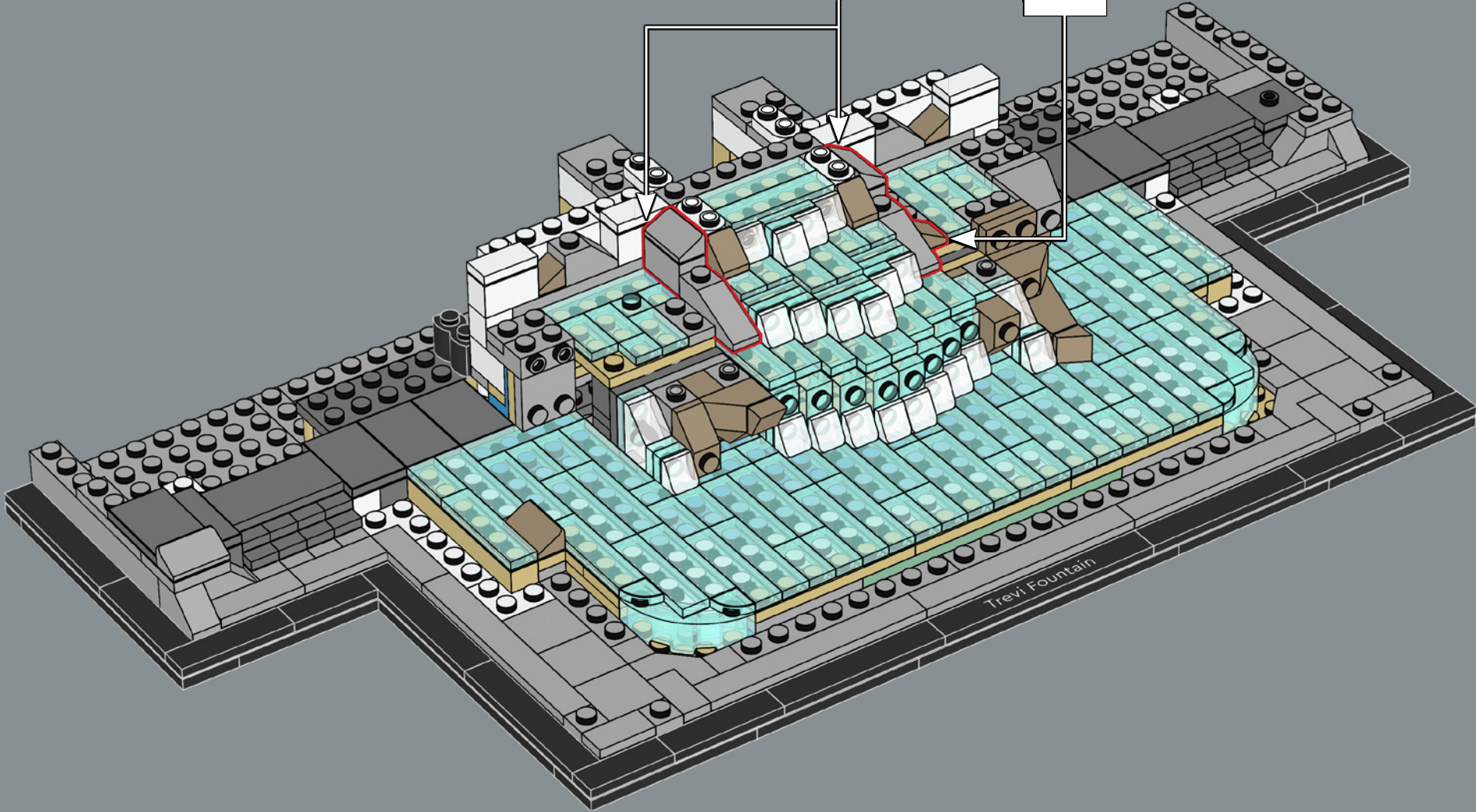
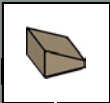
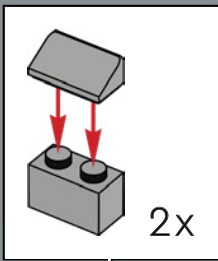

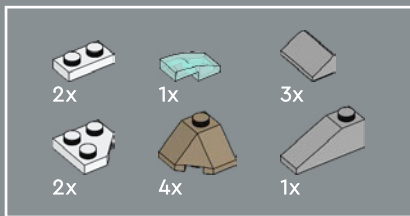

89

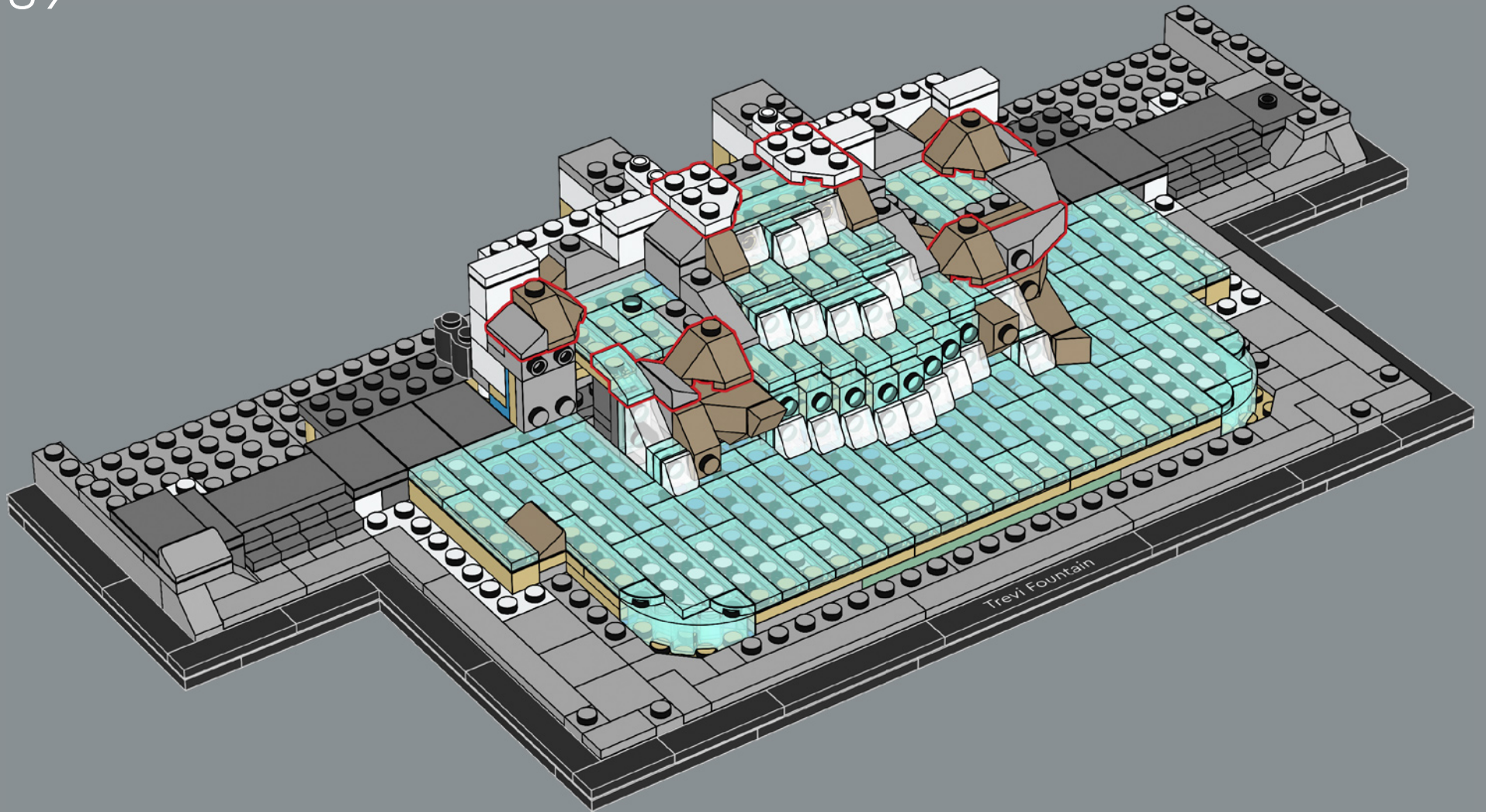

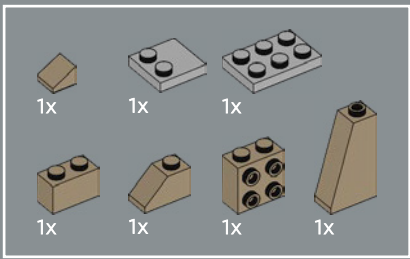

90

1

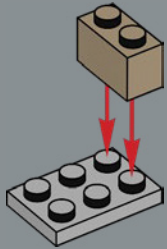

2

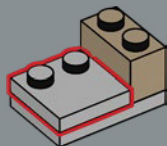

3

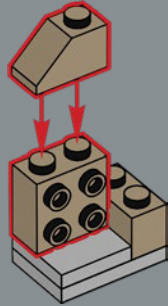

4

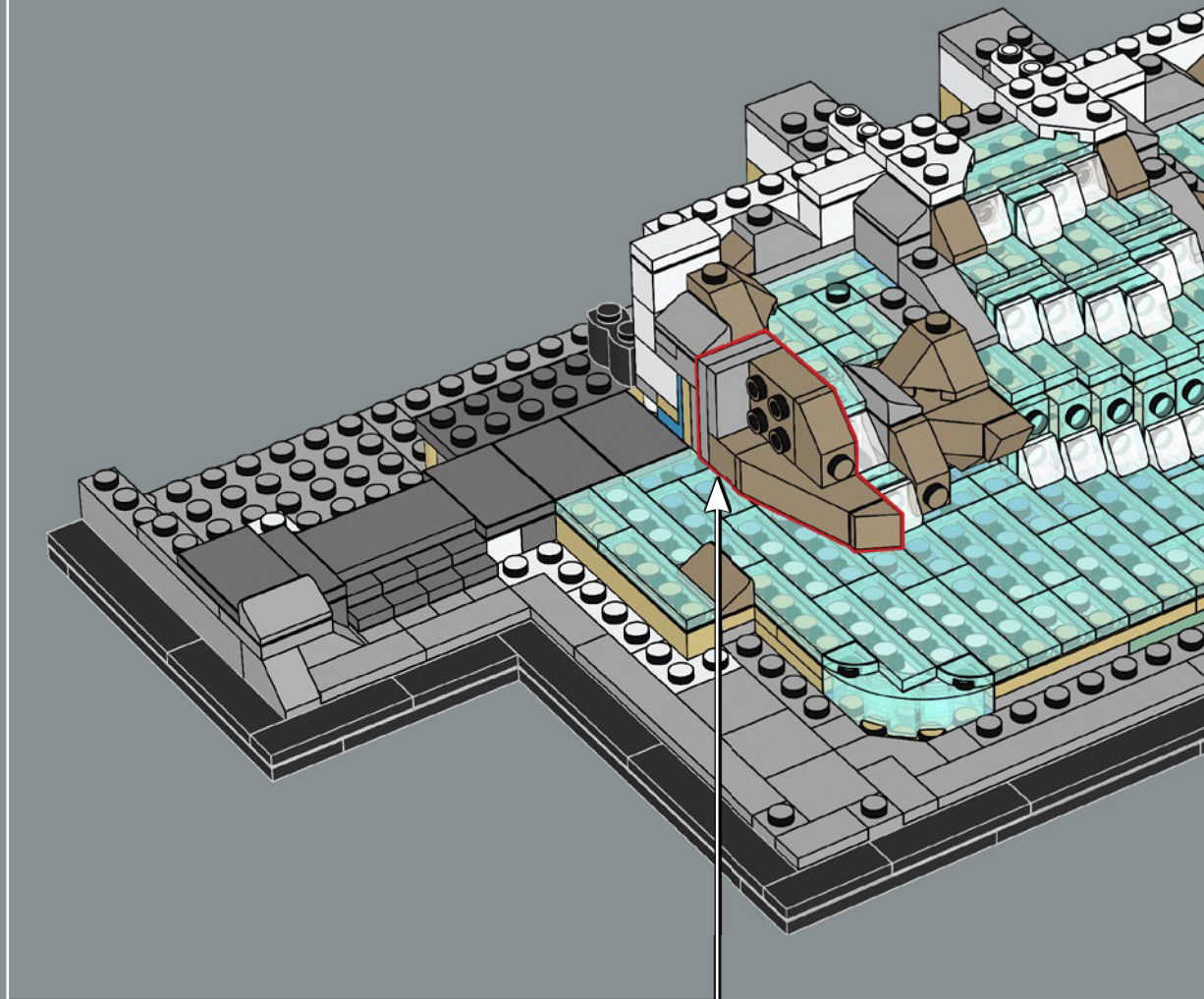
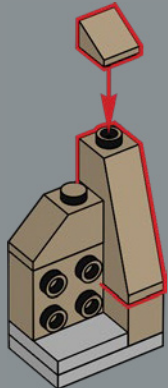

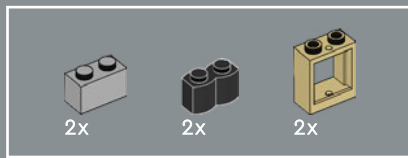

91

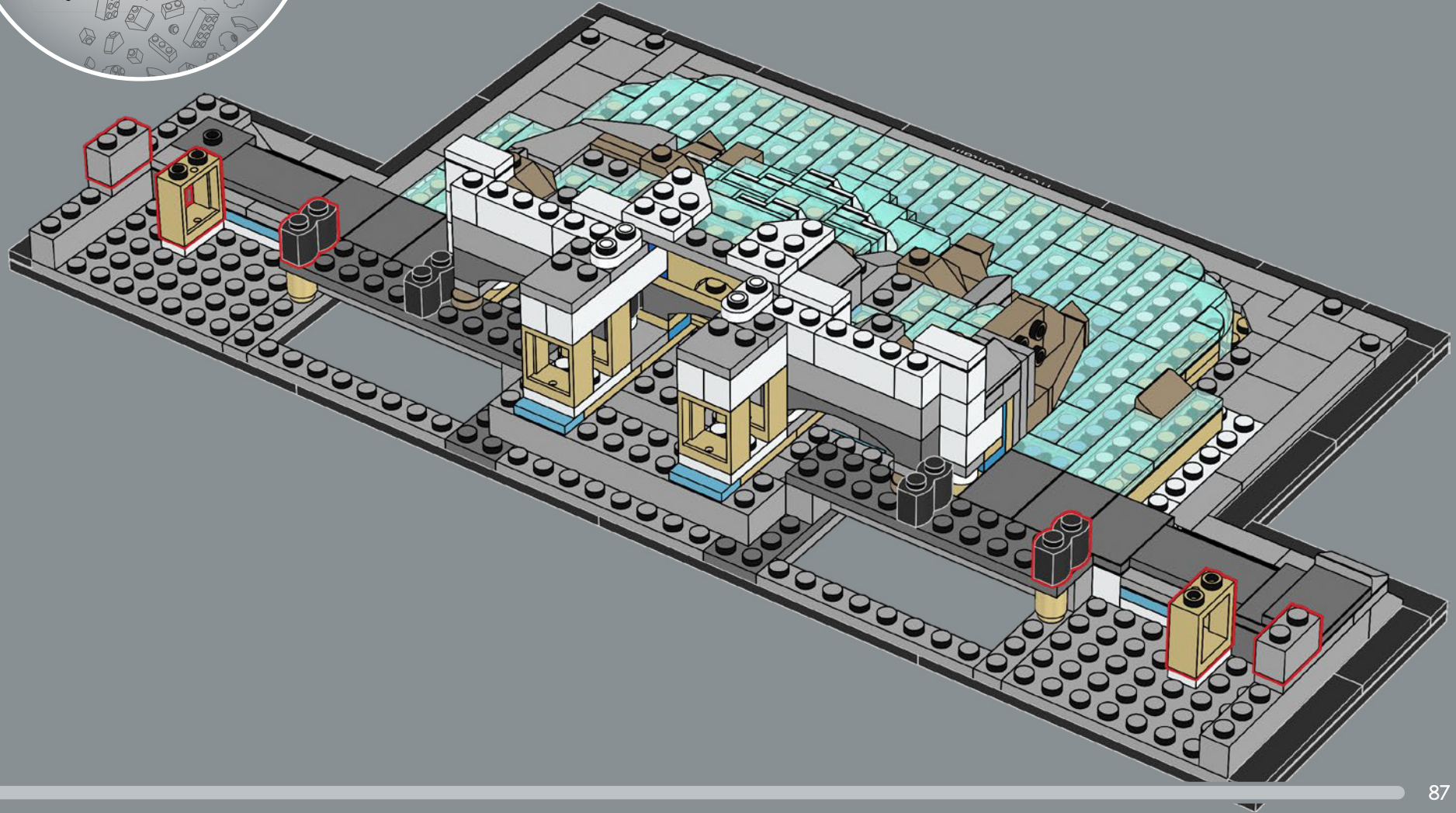

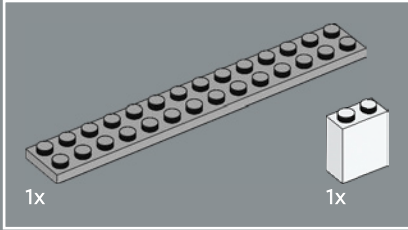
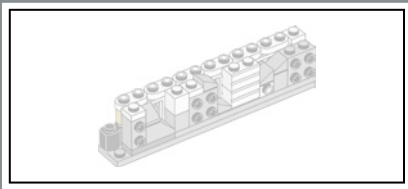

92

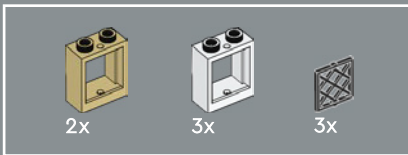
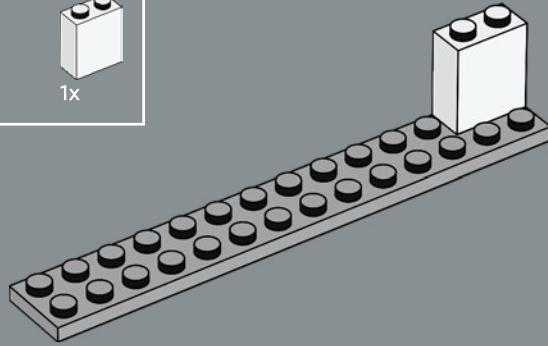

93

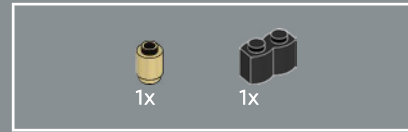
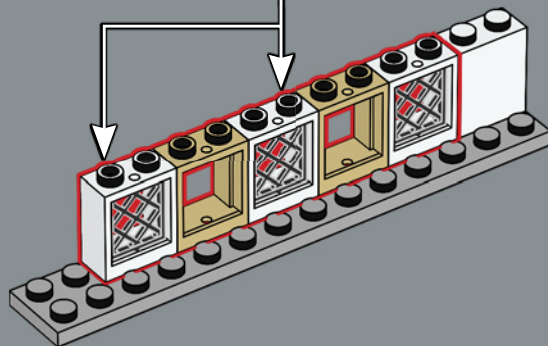
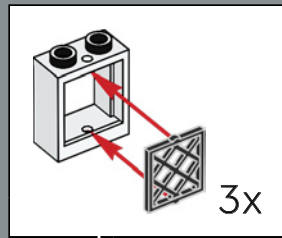

94

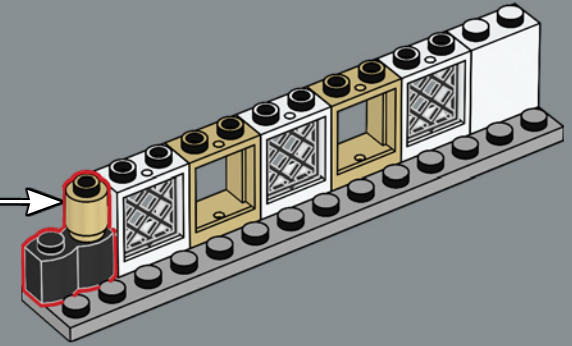
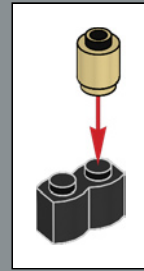

95

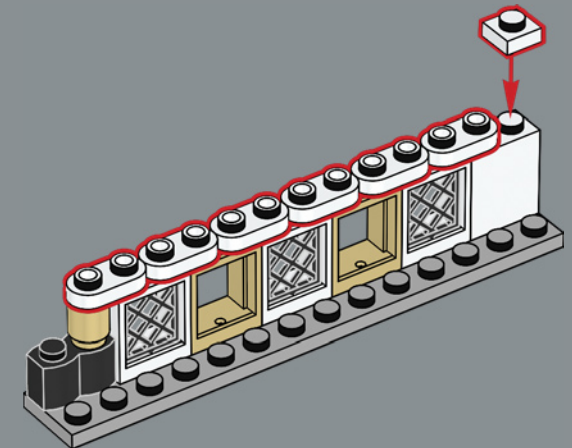



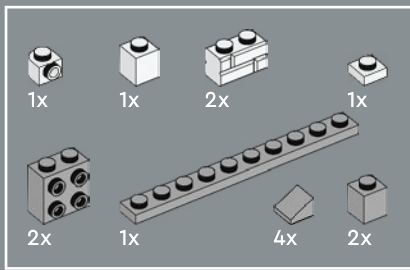

96

Detrás de estas ventanas se encuentran los canales que vierten el agua de los acueductos a la cascada.

1

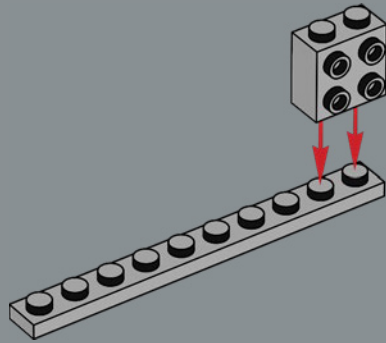

2

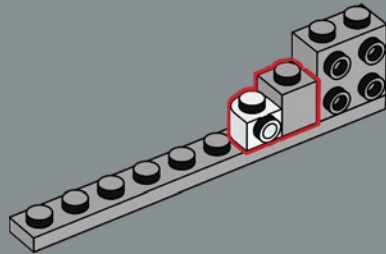

3

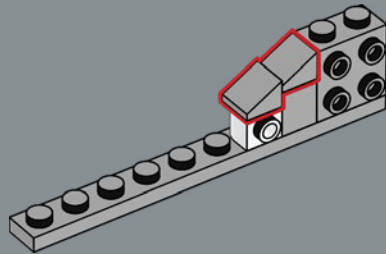

4

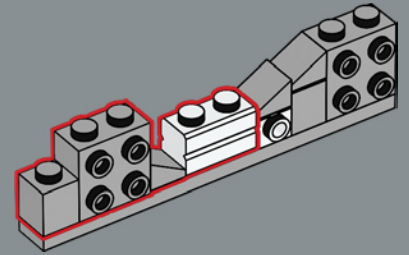

5

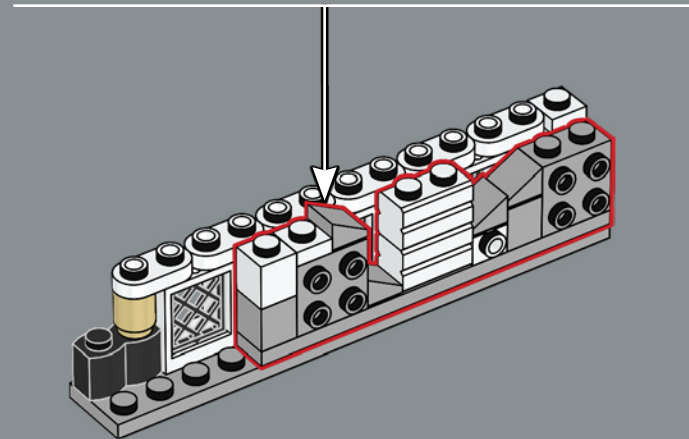
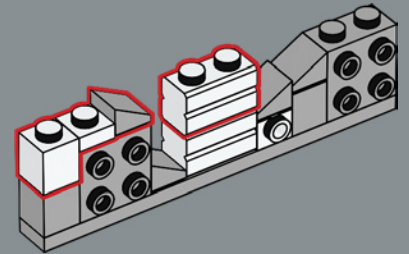

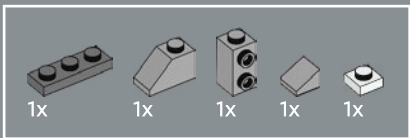

97

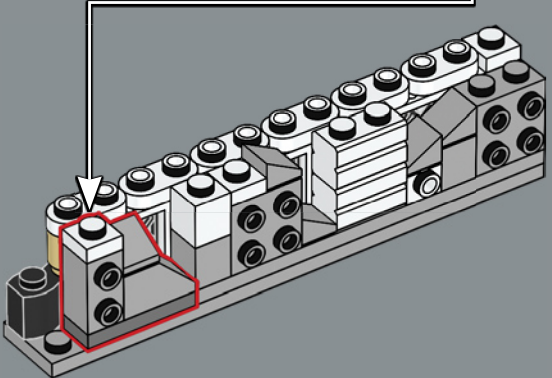
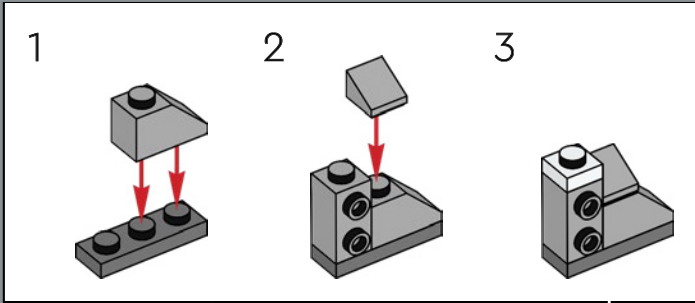

98

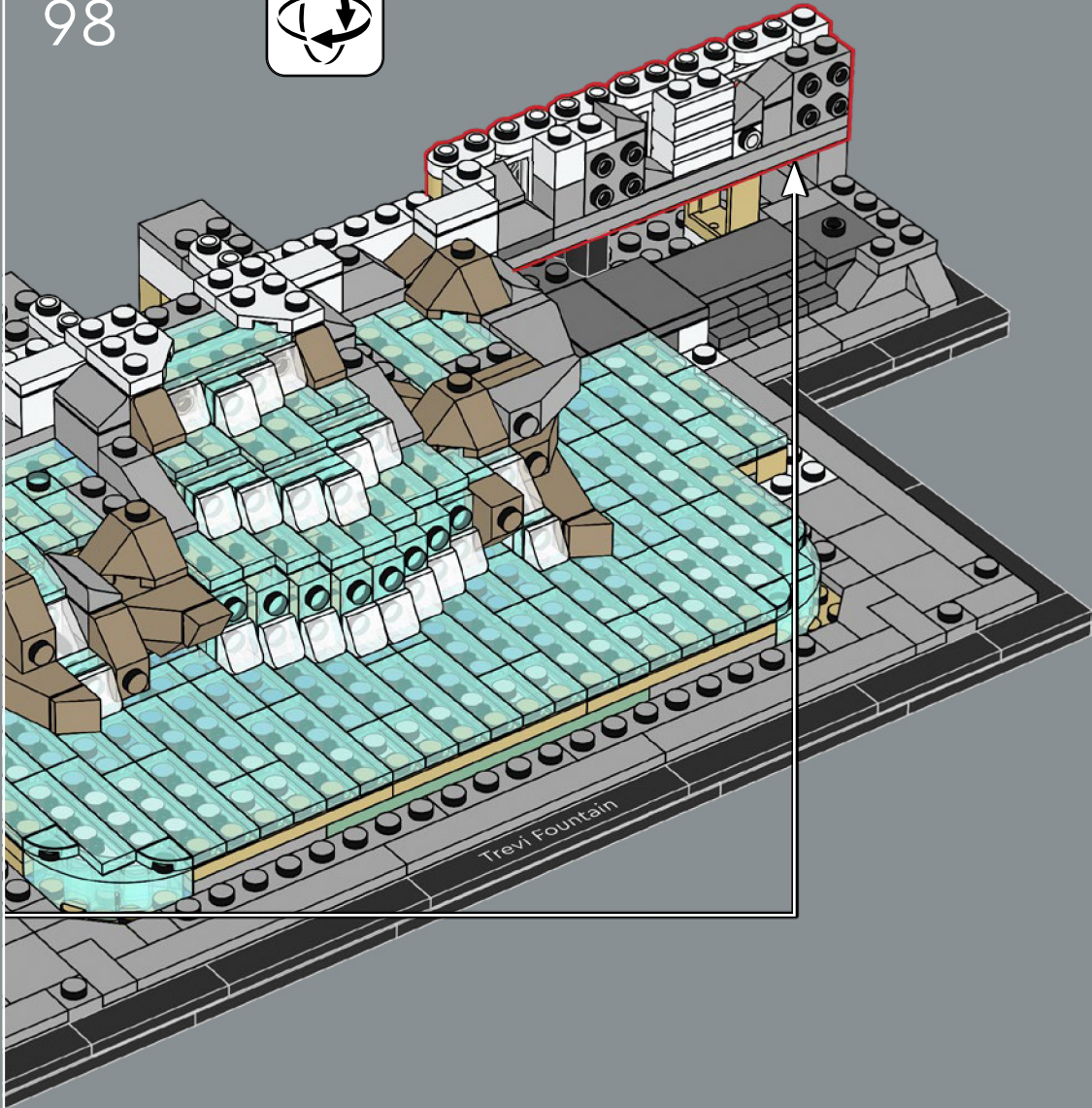

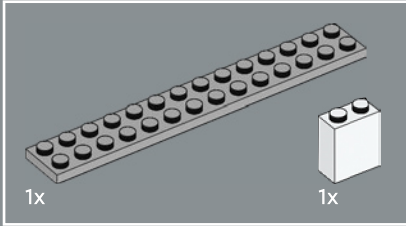
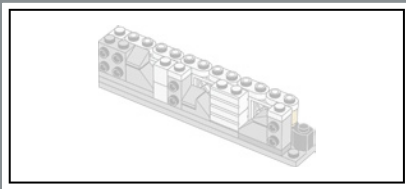

99

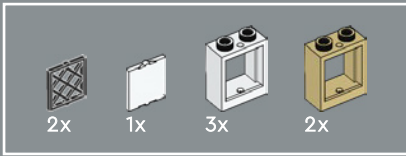
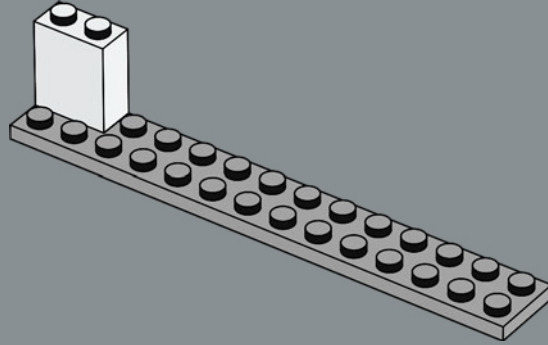

100

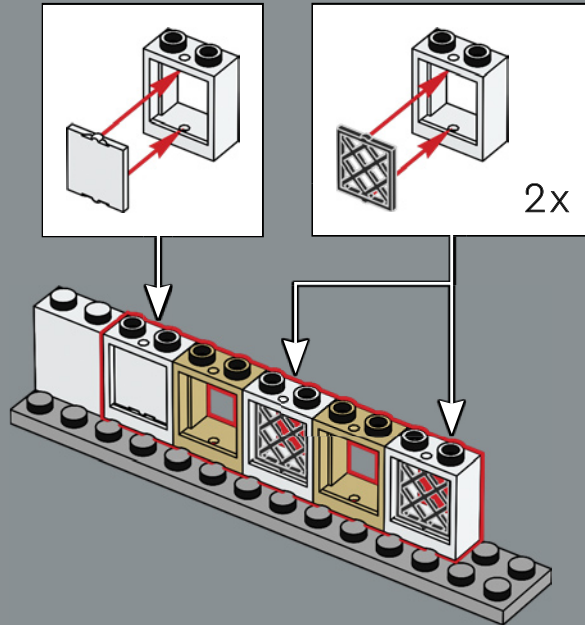

101

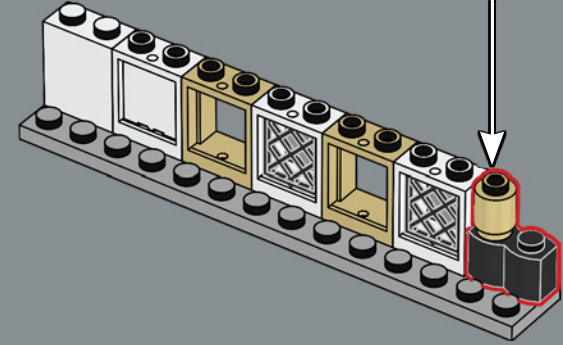
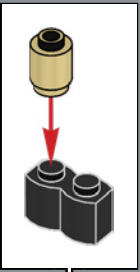

102

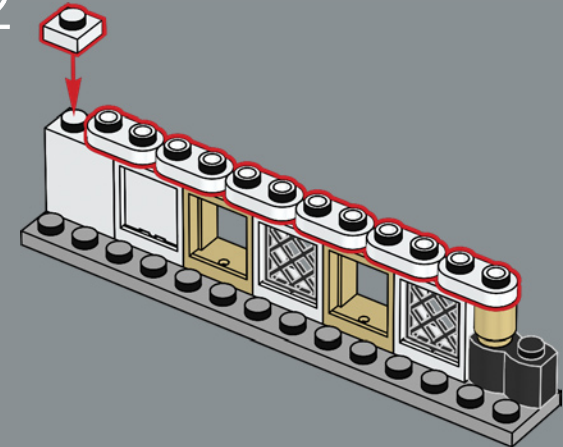

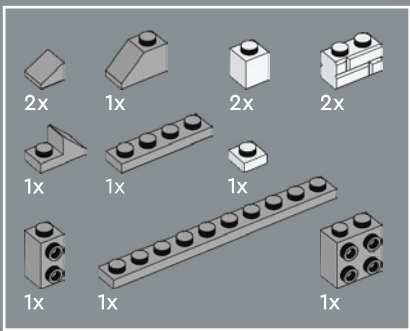

103

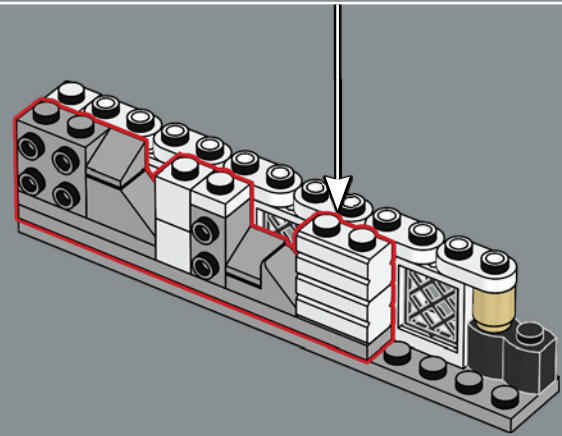
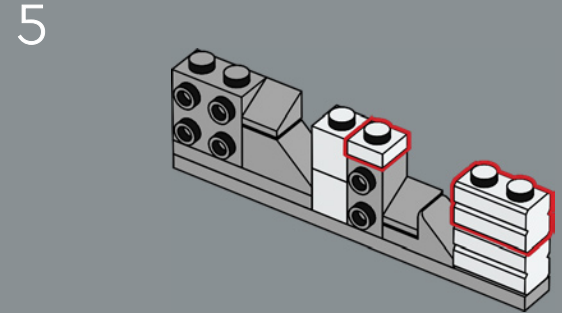
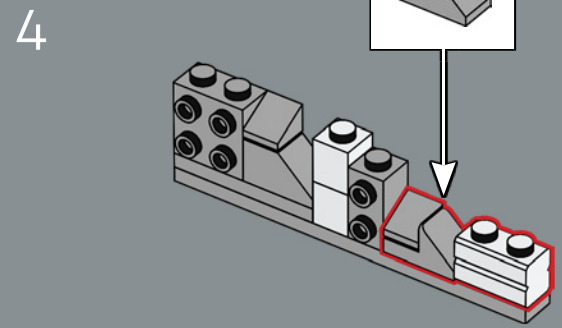
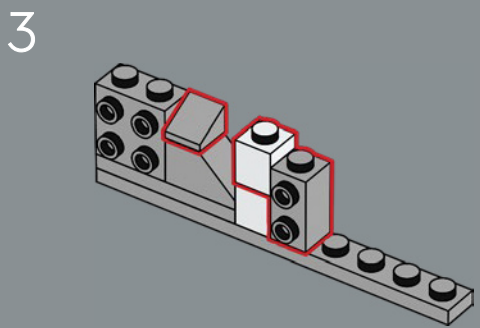
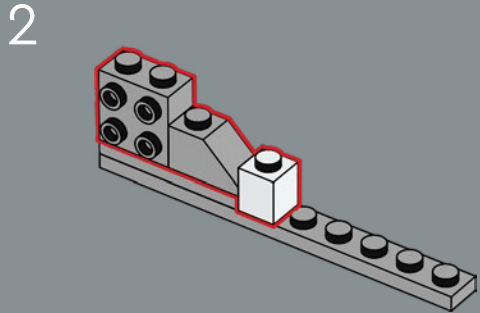
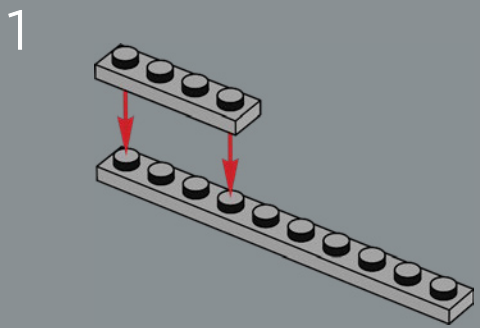

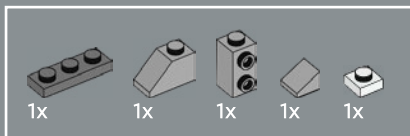

104

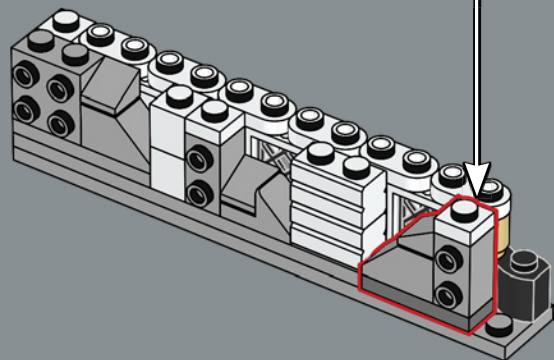
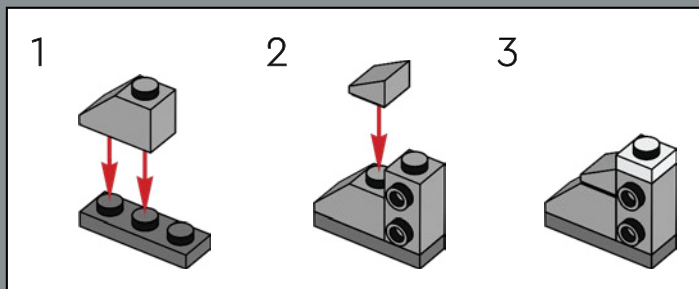

105

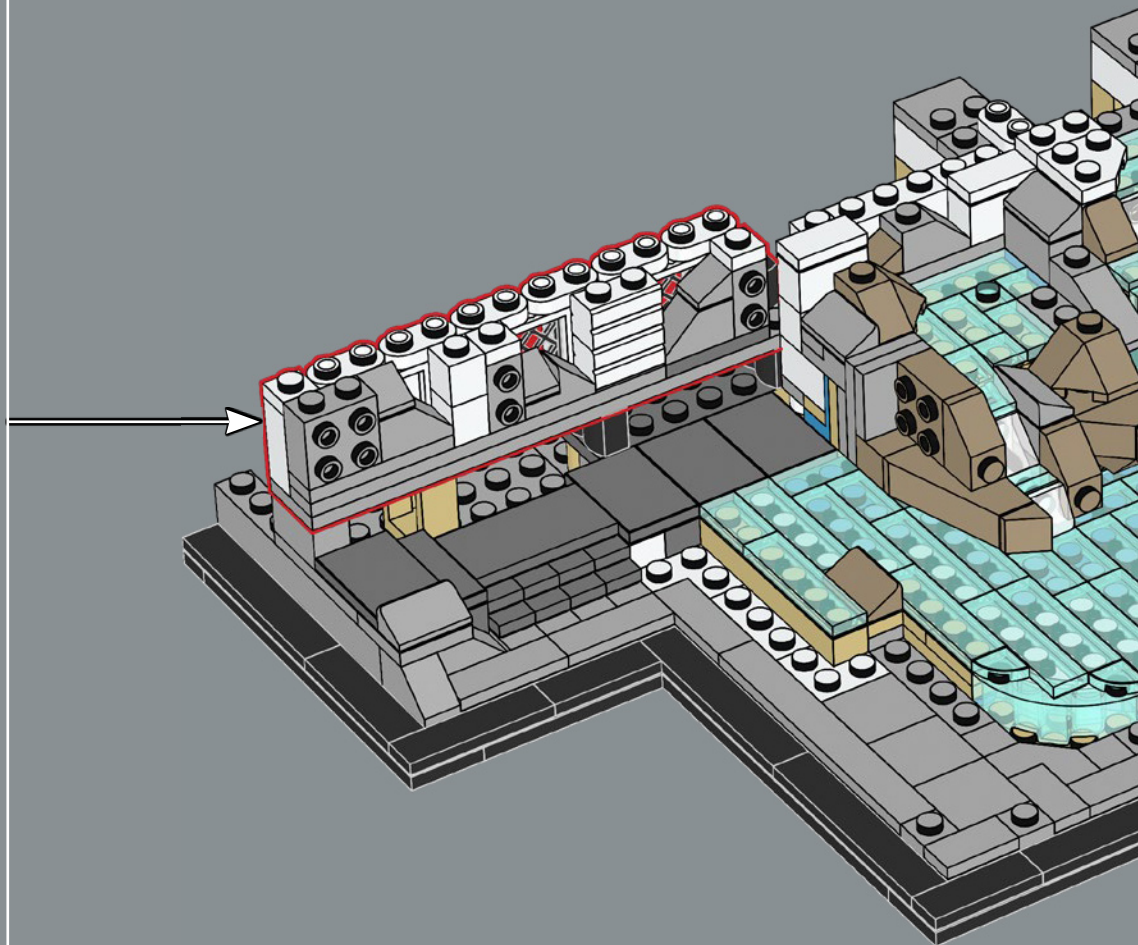

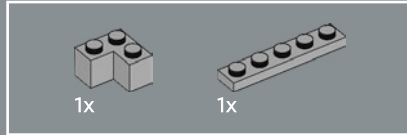
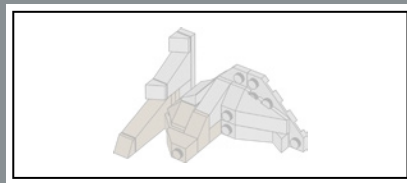

106

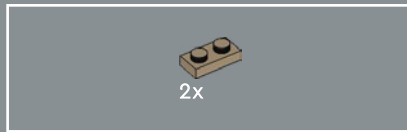
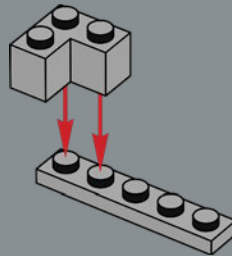

107

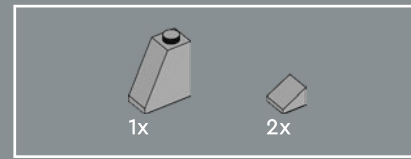
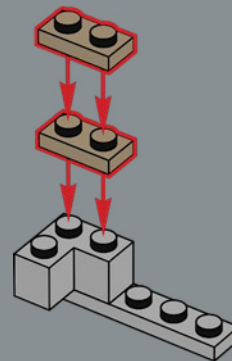

108

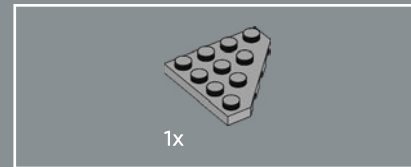
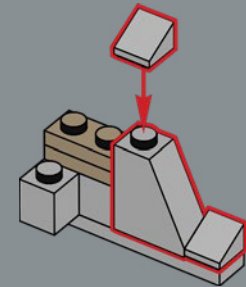

109

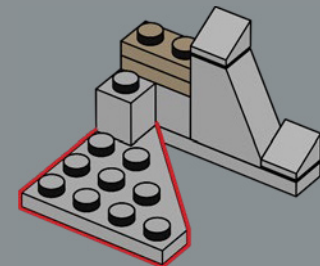

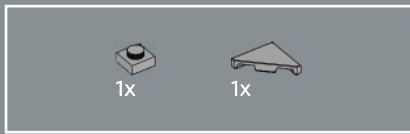

110

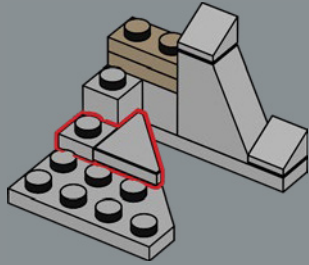

112

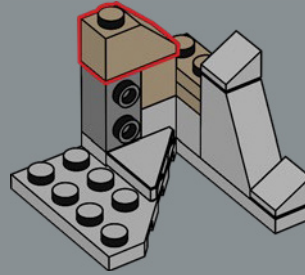

114

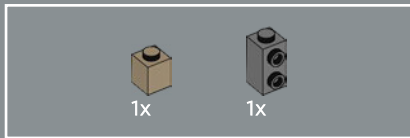
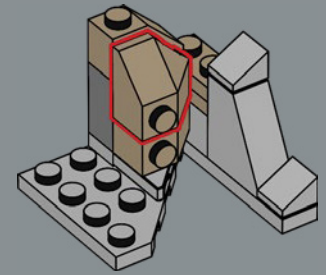

111

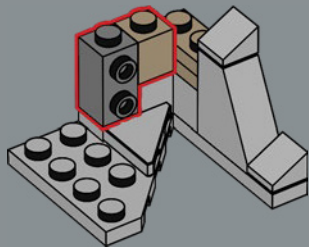

113

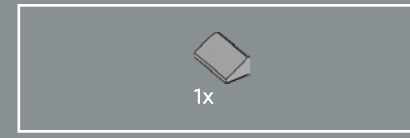
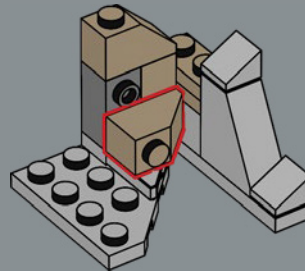

115

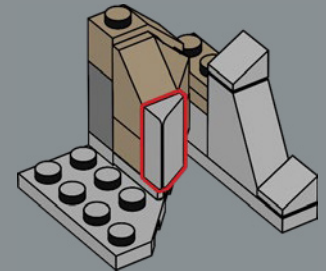

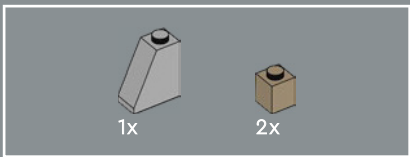

116

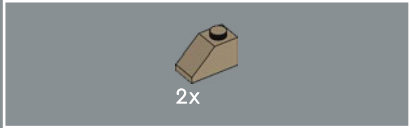
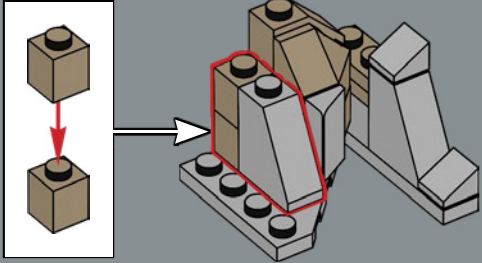

117

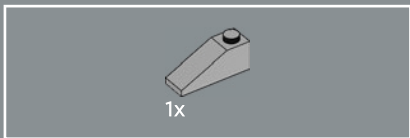
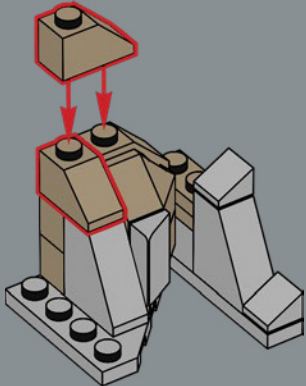

118

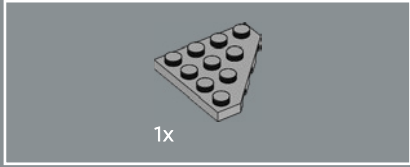
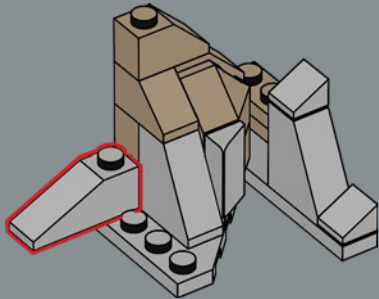

119

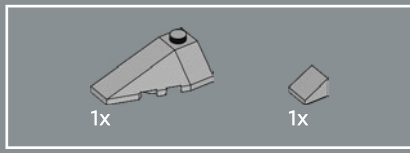
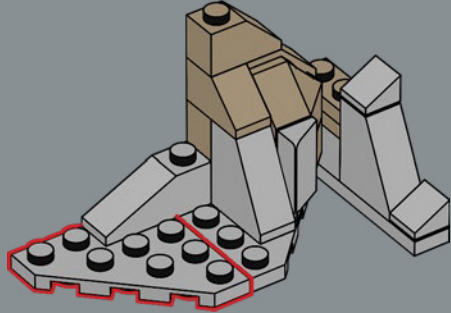

120

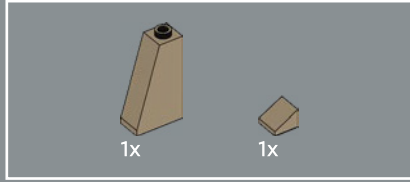
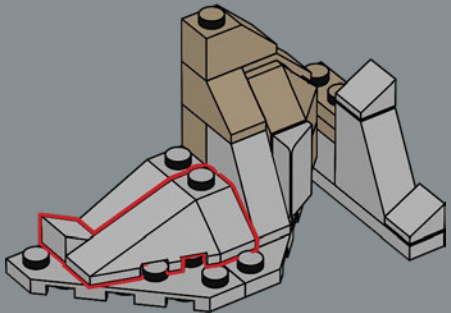

121

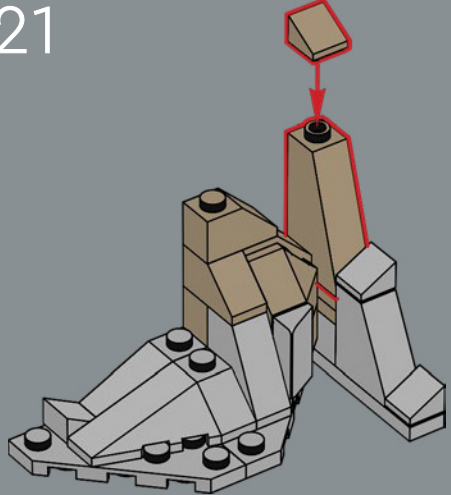



122

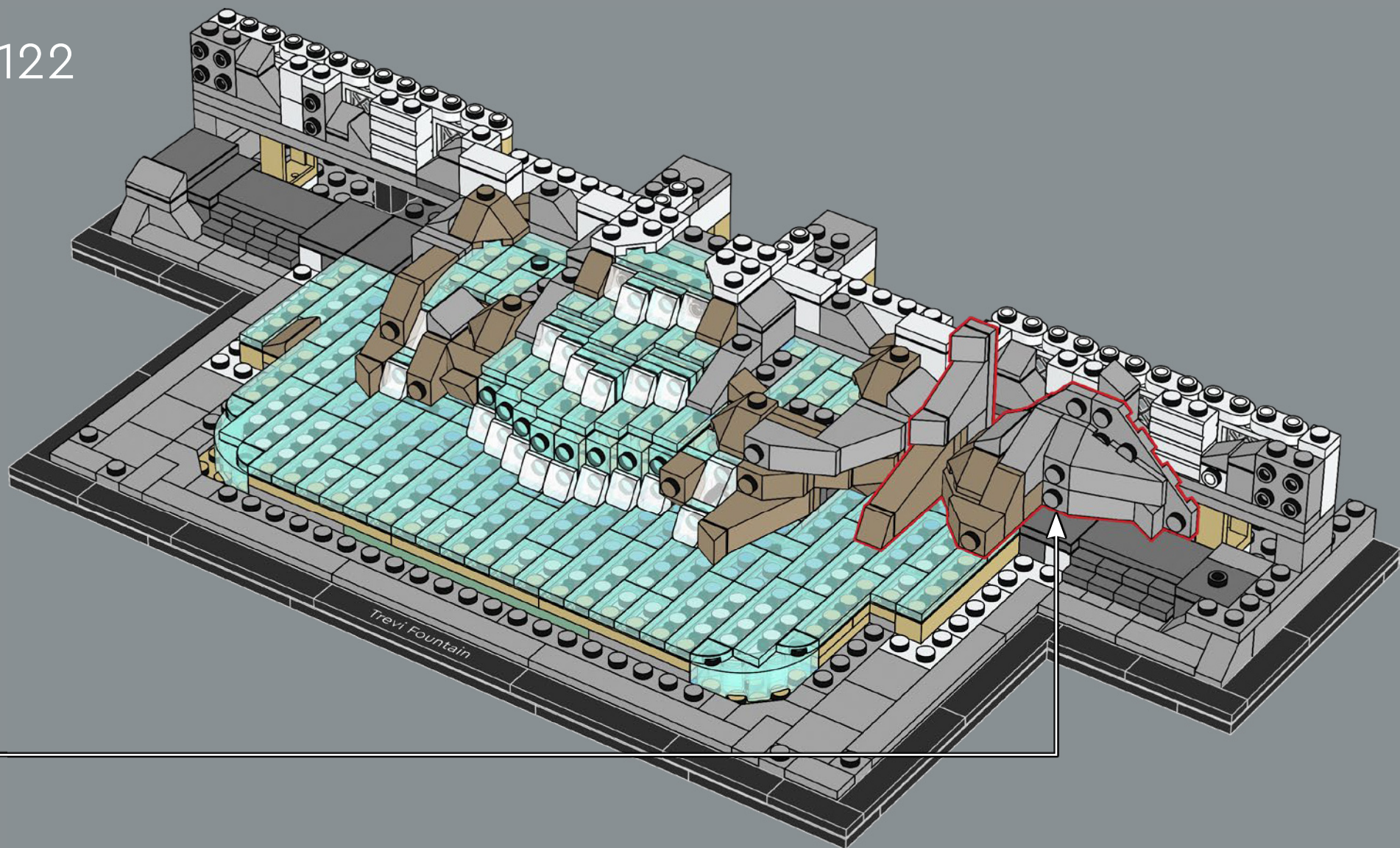

La cantería es uno de los pocos detalles que trastoca la simetría general de la estructura barroca, aportando con sus formas orgánicas un impresionante contraste con el resto de la fachada.

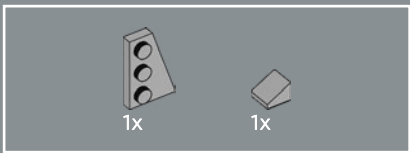

123

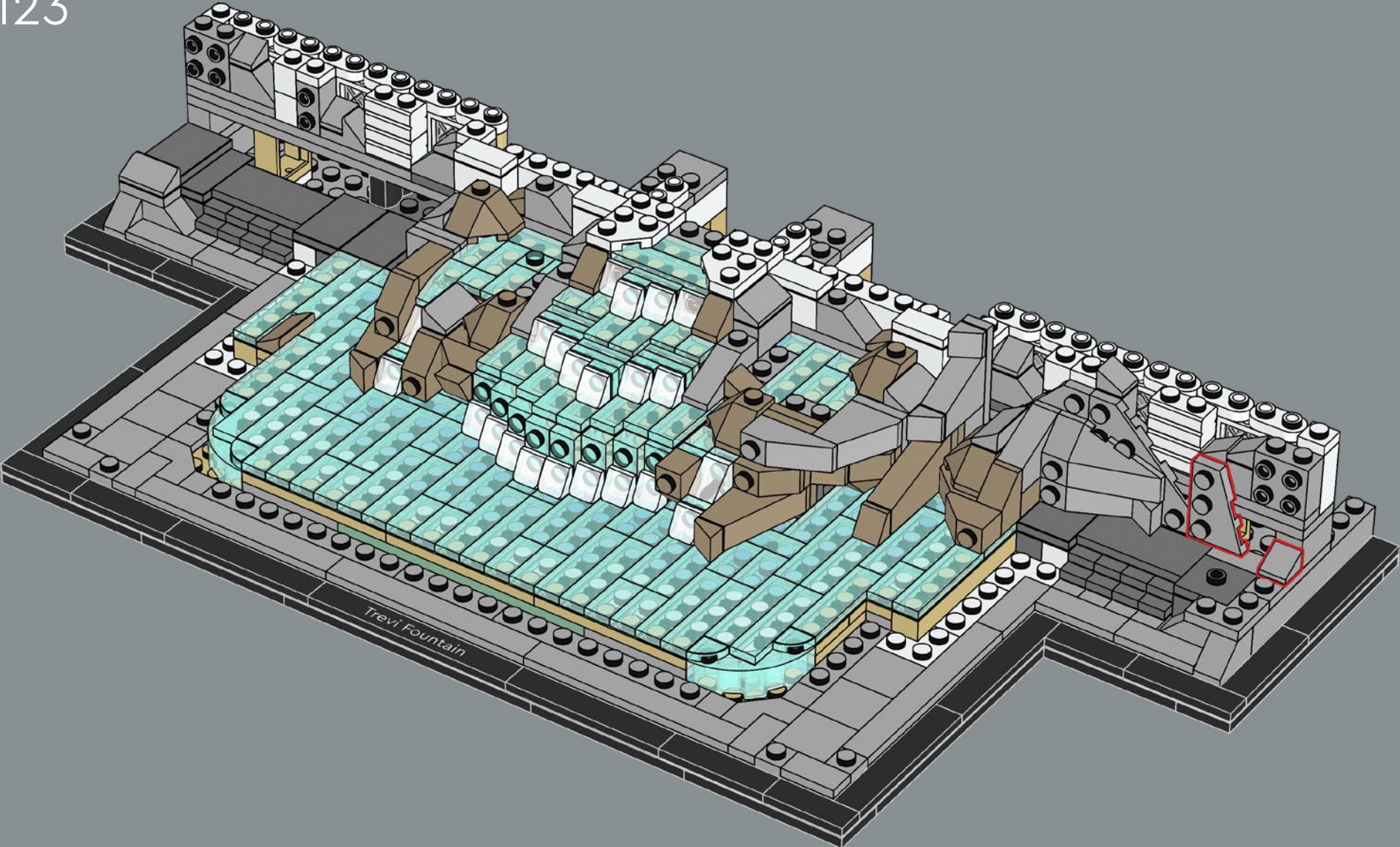

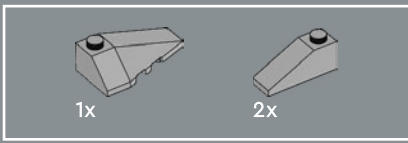

124

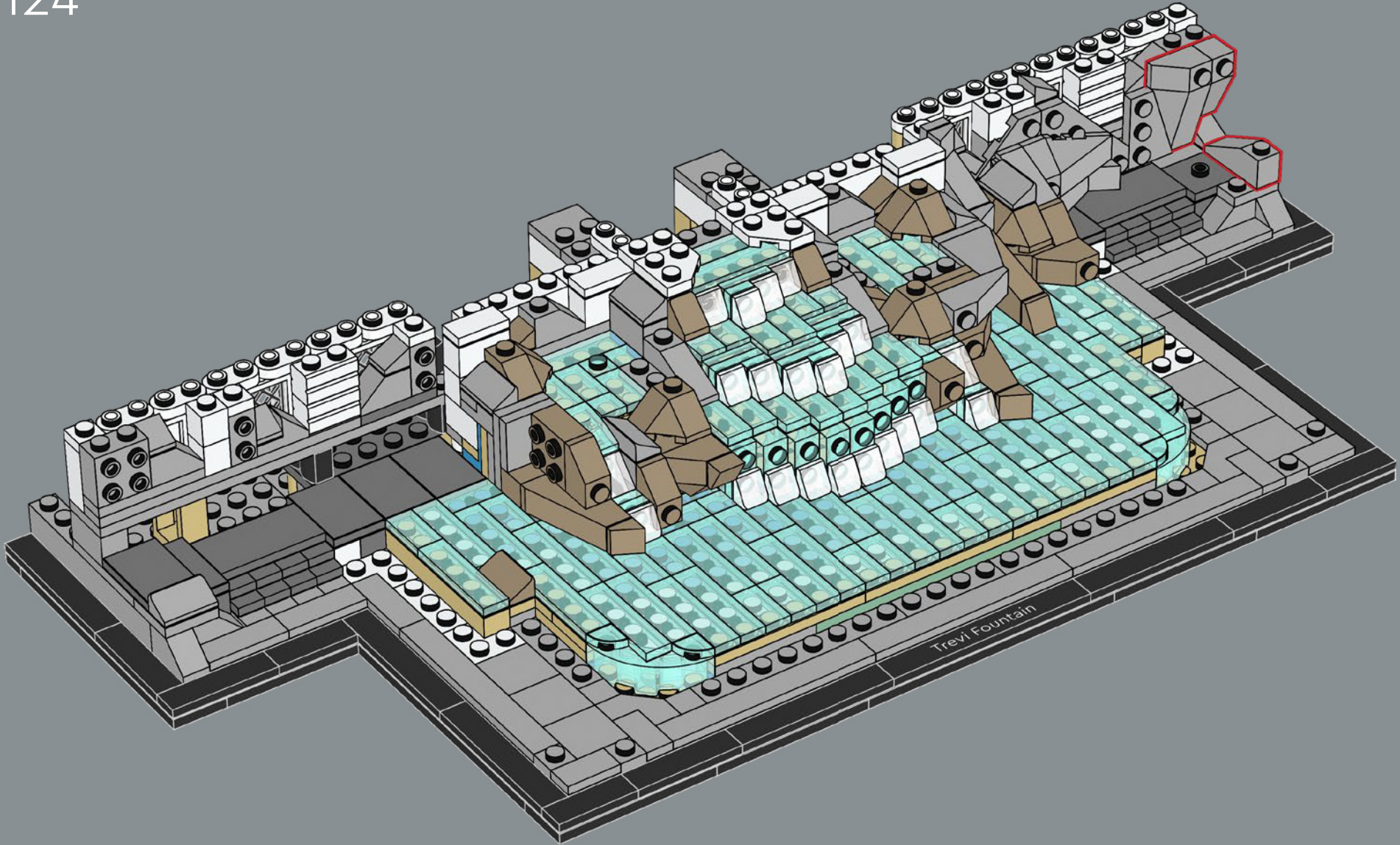

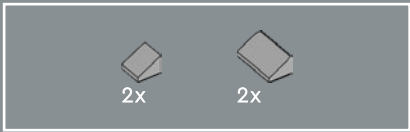

125

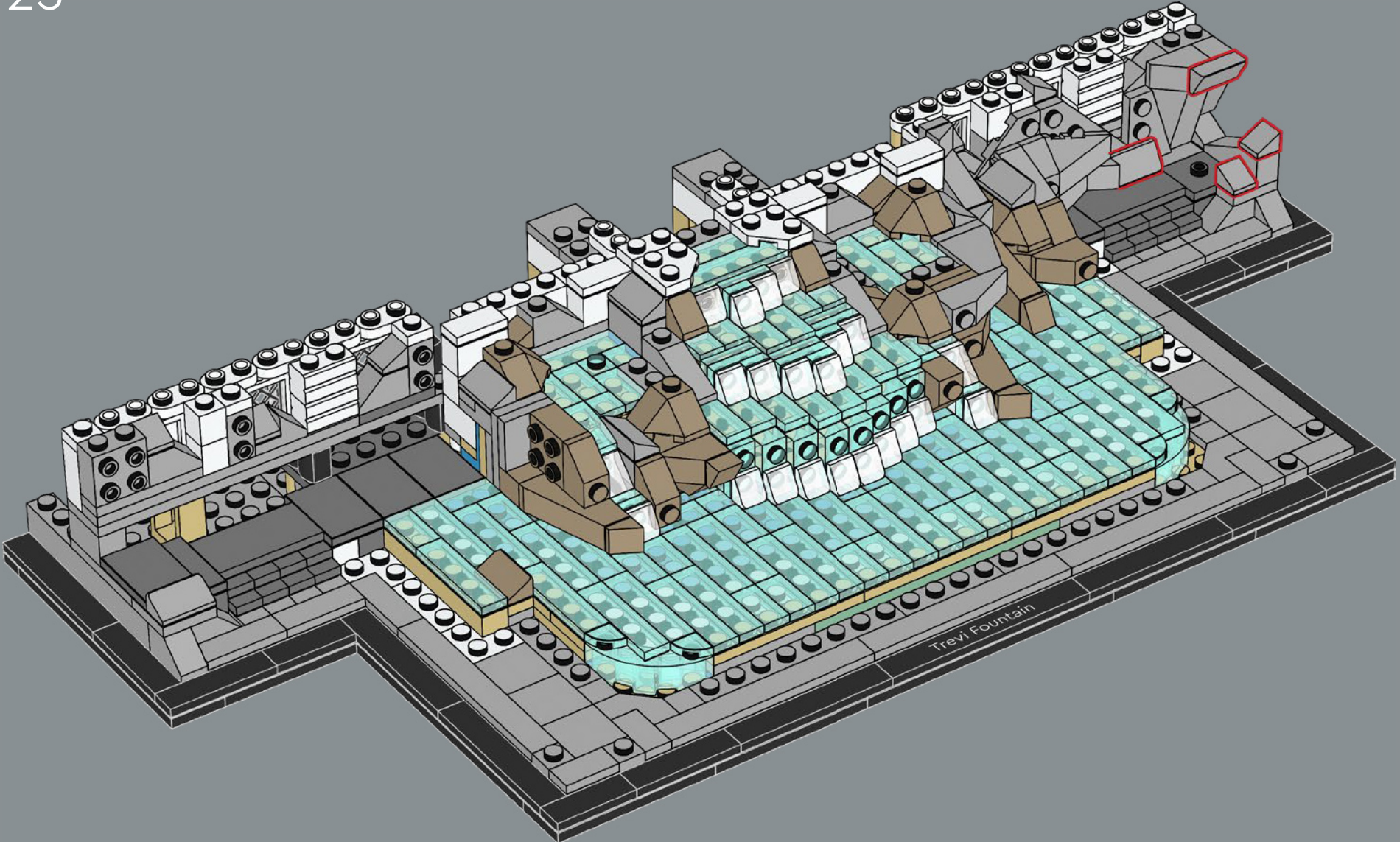

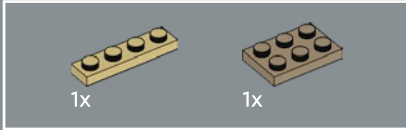
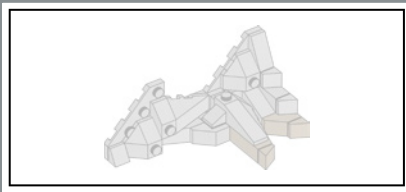

126

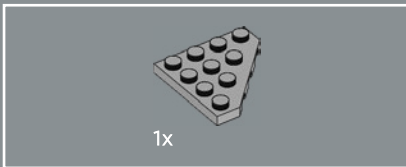
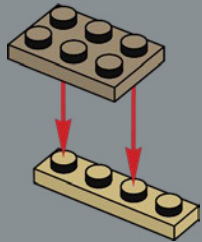

127

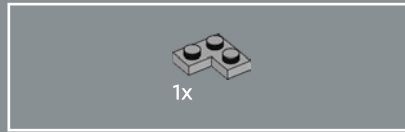
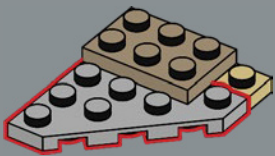

128

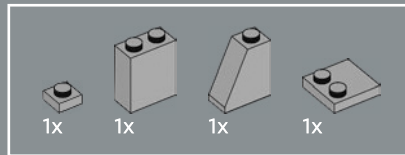
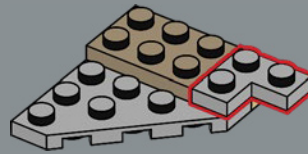

129

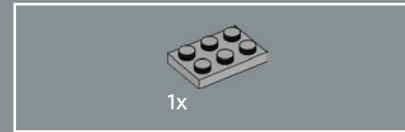
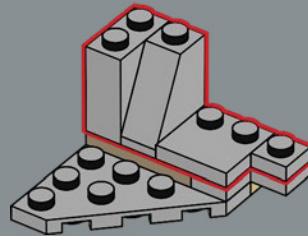

130

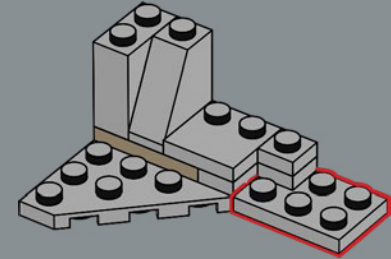

131

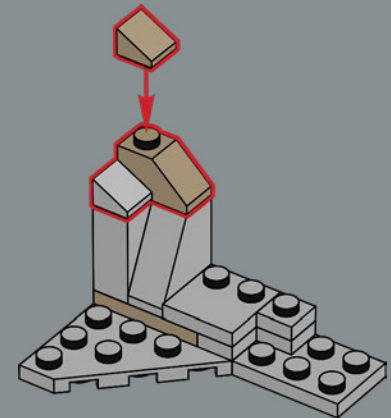



132

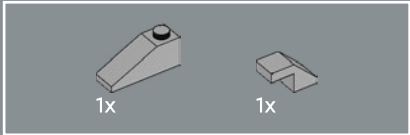
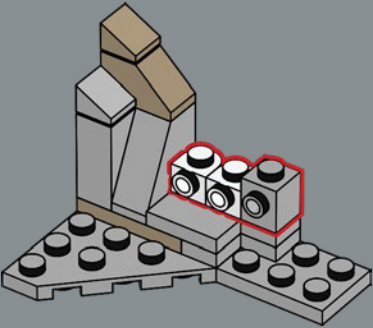

133

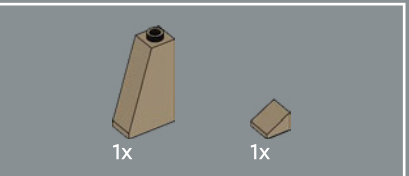
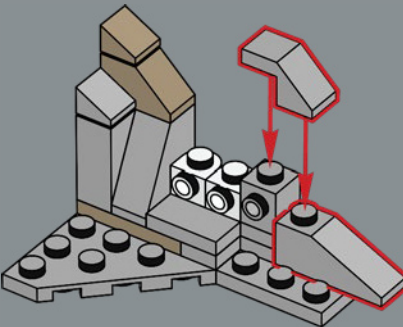

134

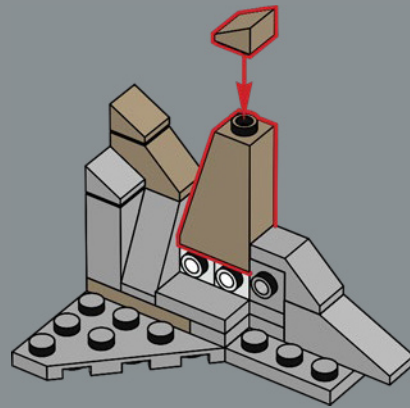

135

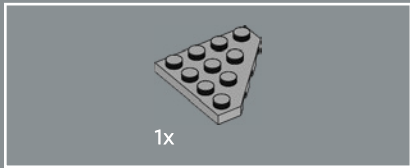
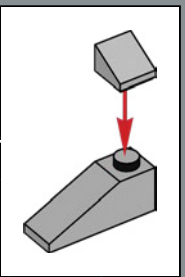
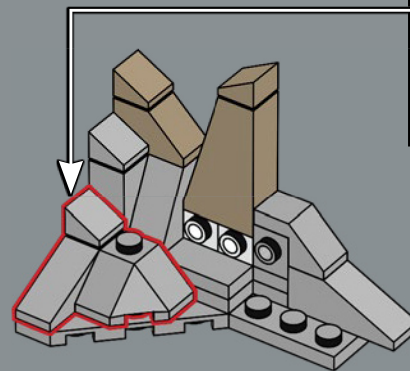

136

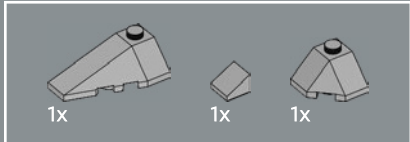
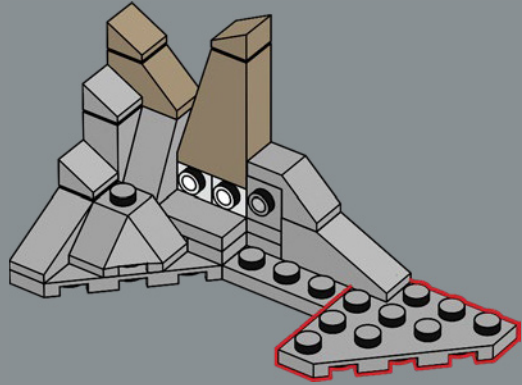

137

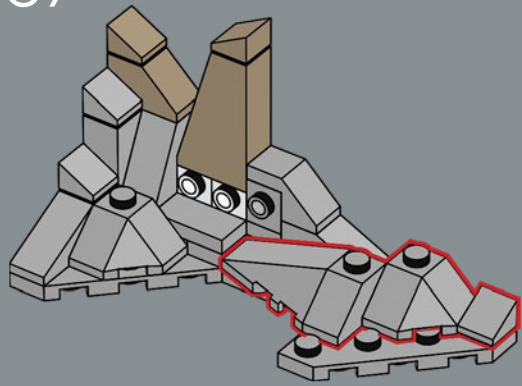

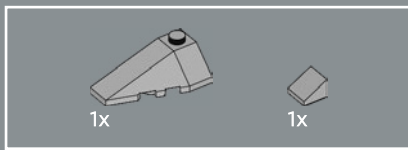

138

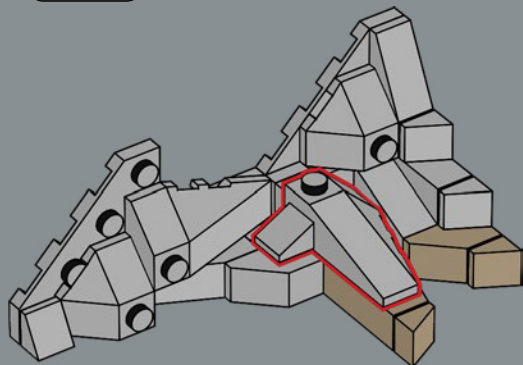

139

Hasta el desgaste natural de la fuente influye en cómo se ve. La degradación ambiental se acumula en los rincones y recovecos de la fachada tallada, y deja incluso marcas poco profundas de color más oscuro que la roca circundante.

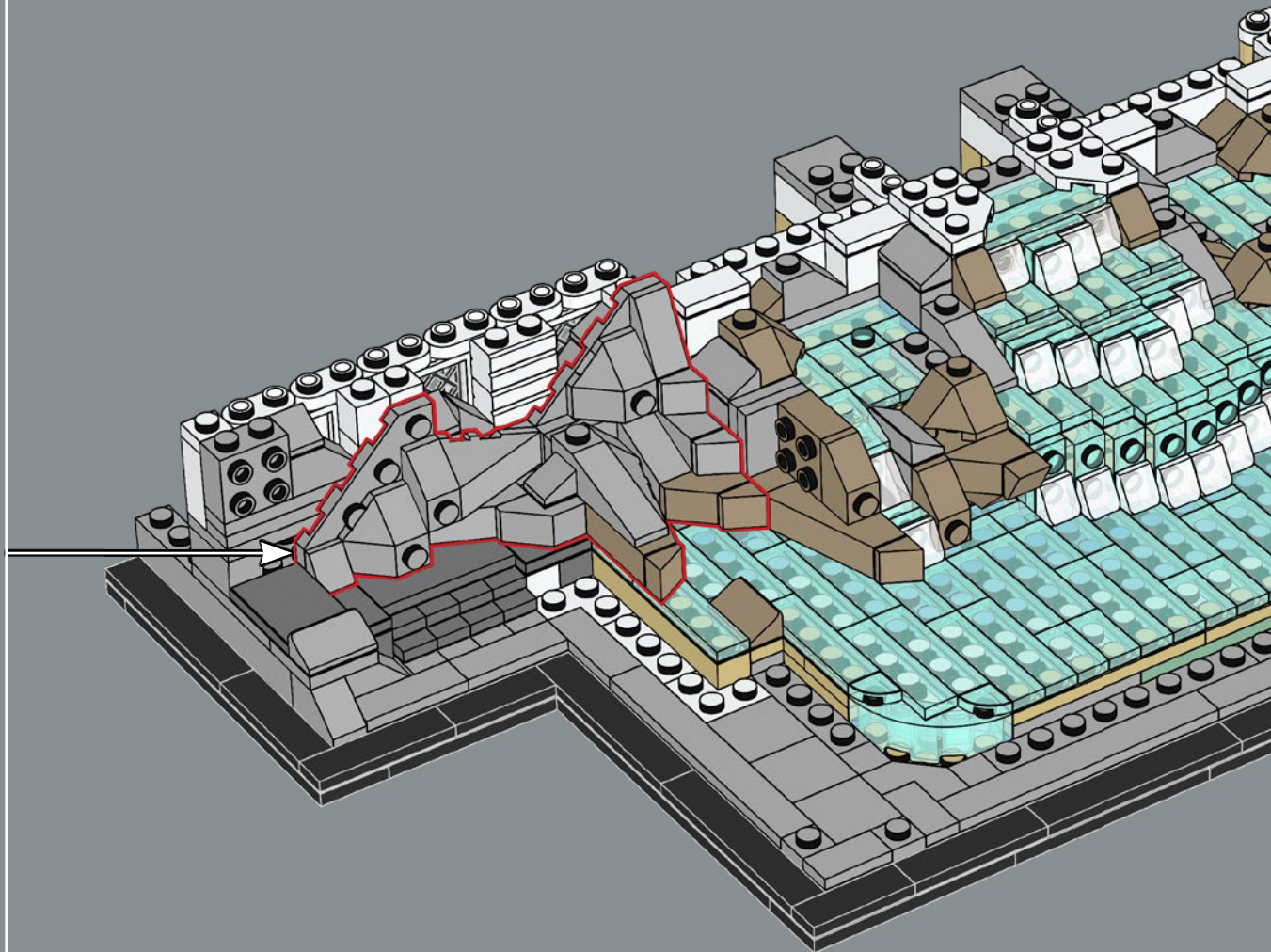

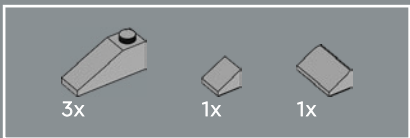

140

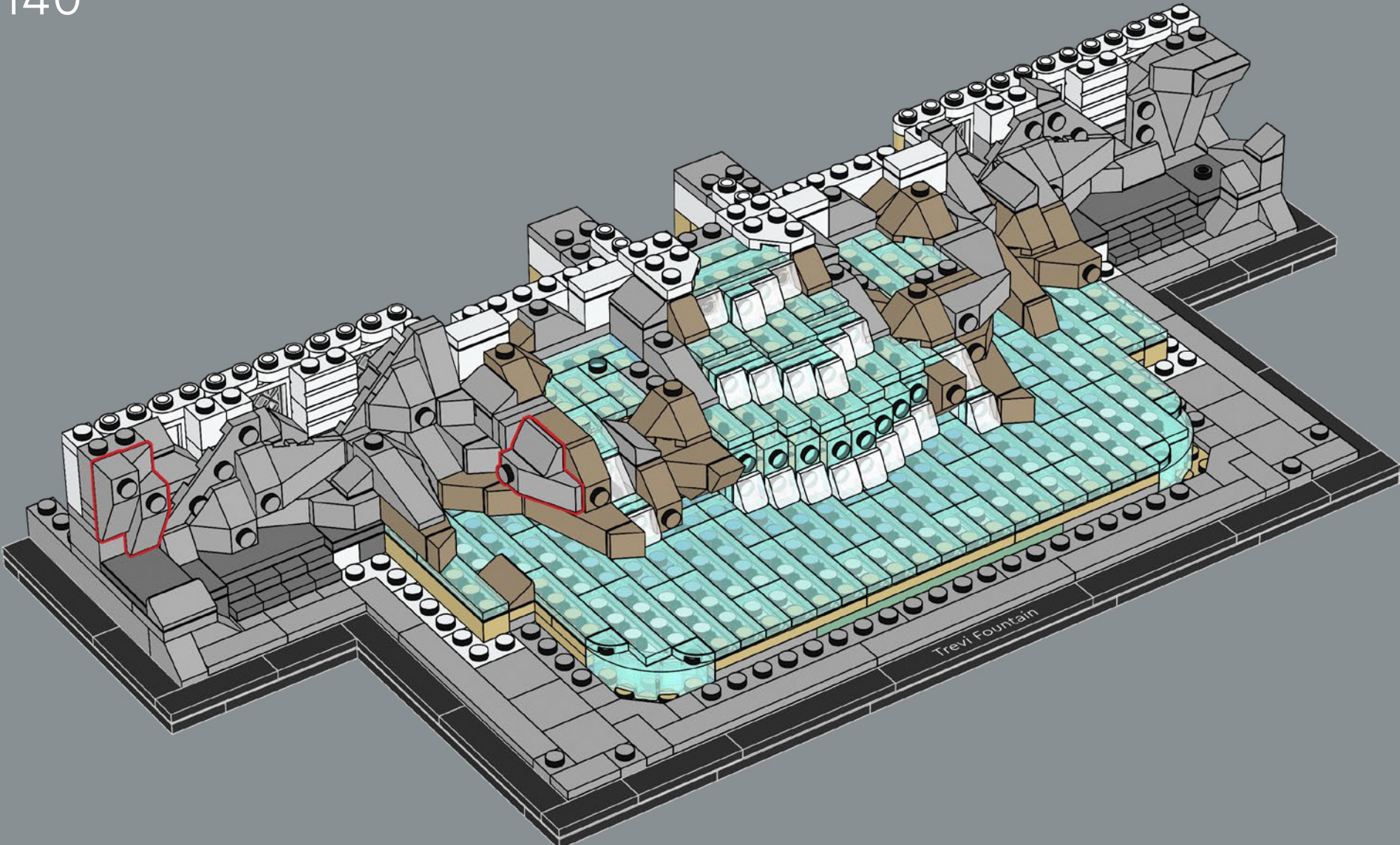



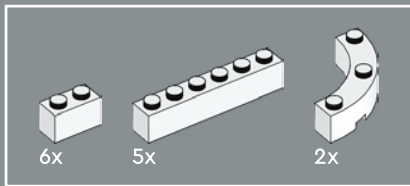

141

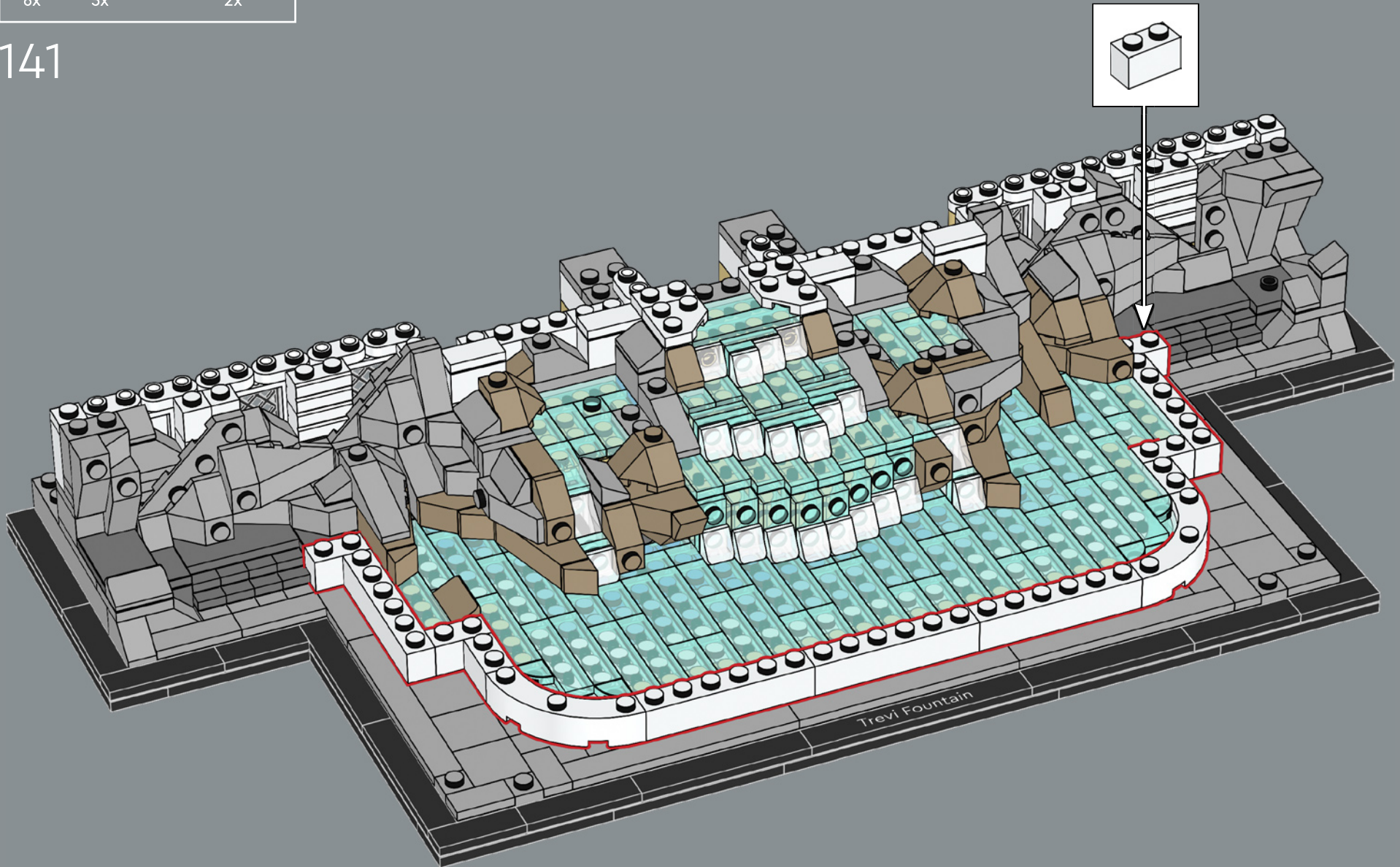

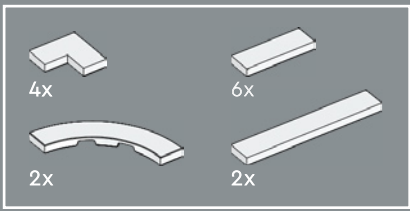

142

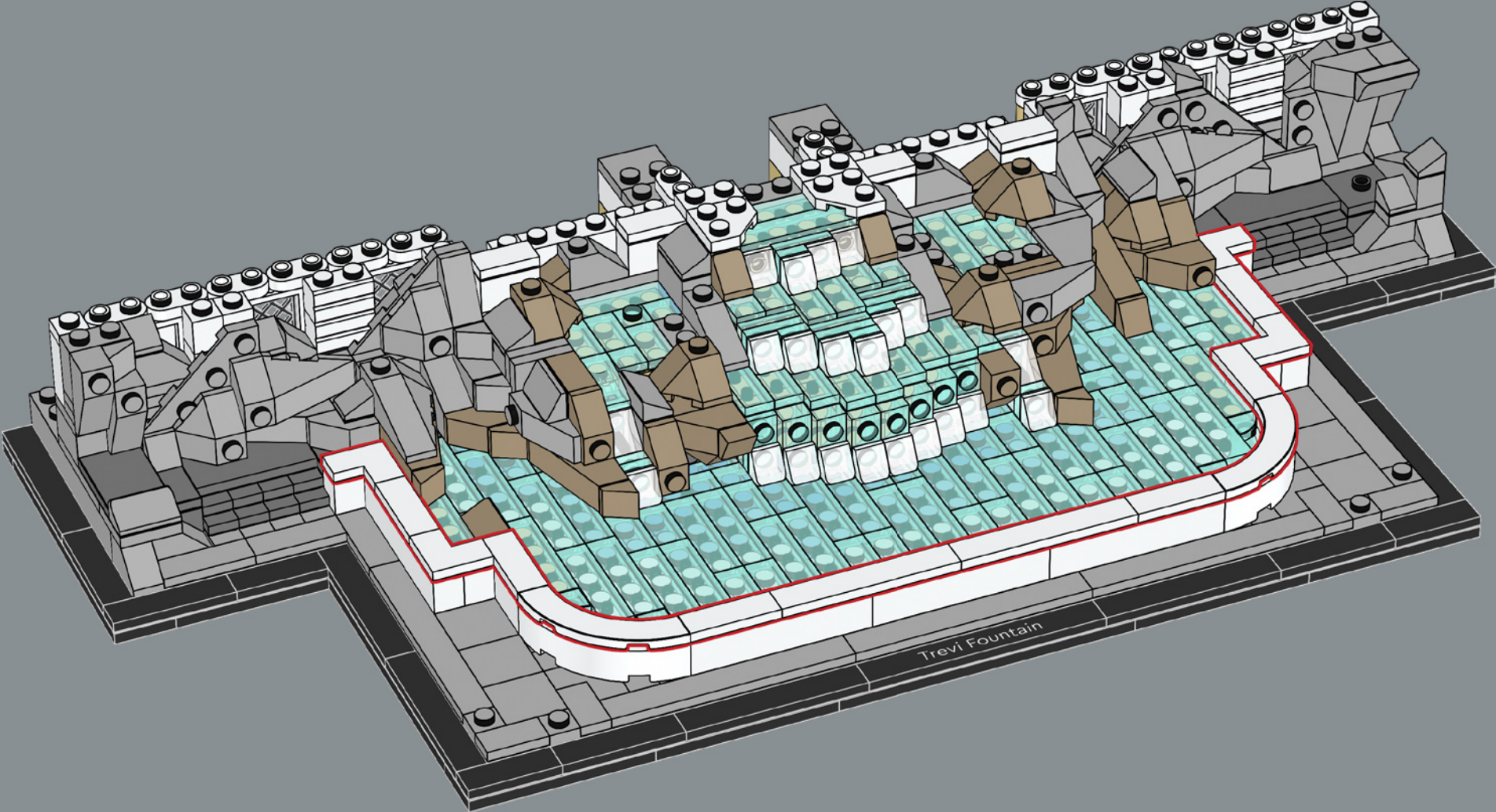

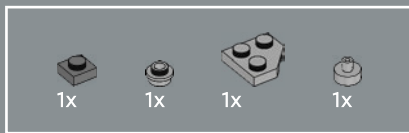

143

Esta fuentecita se conoce con el nombre de Fontanella degli Innamorati (Fuente de los Enamorados) por sus chorros de agua cruzados. Según la leyenda, las parejas que beben en ella permanecerán enamoradas y fieles para siempre.

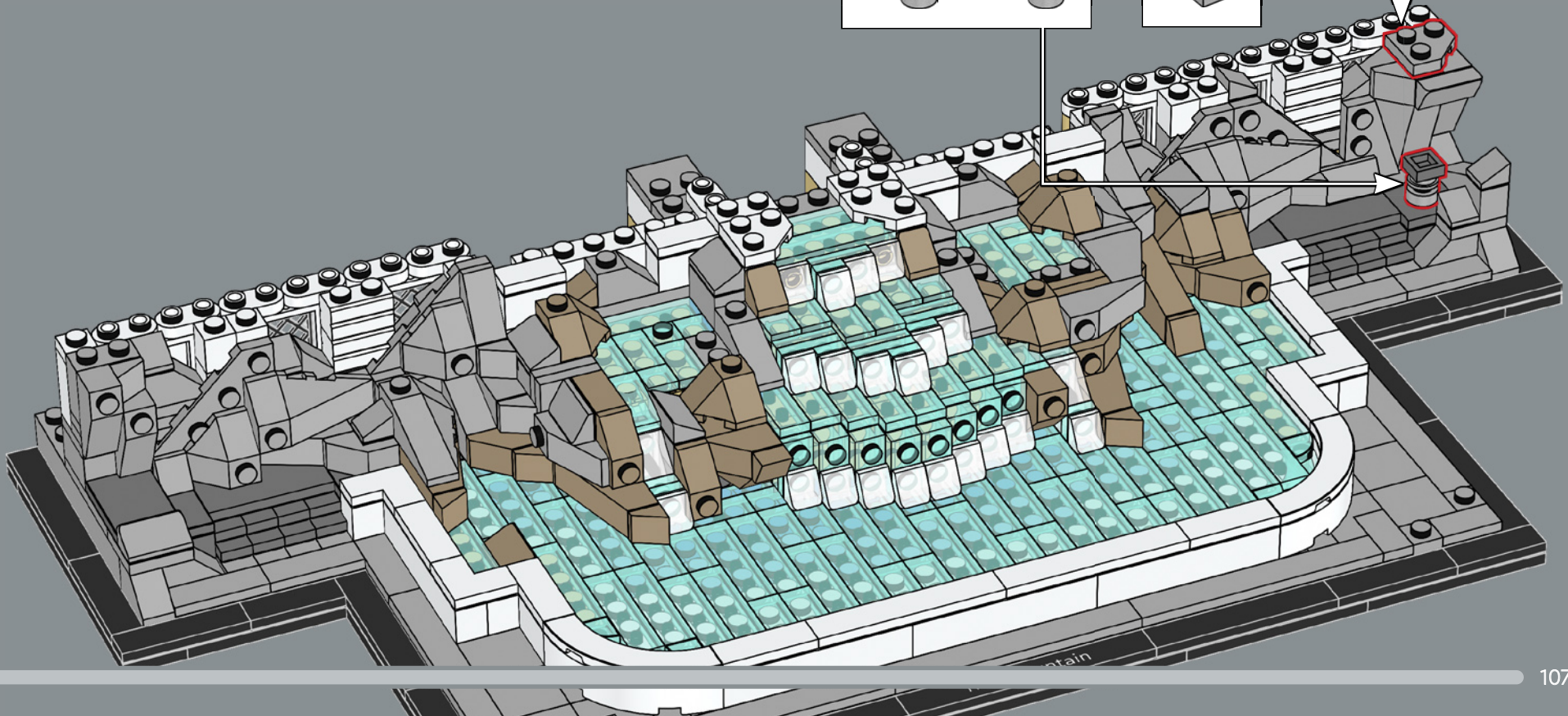
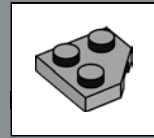
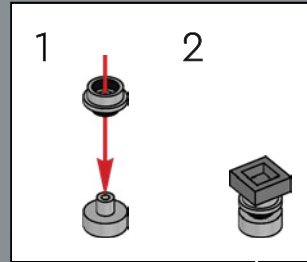

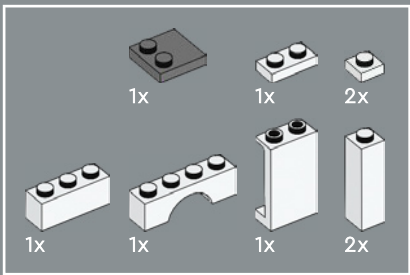

144

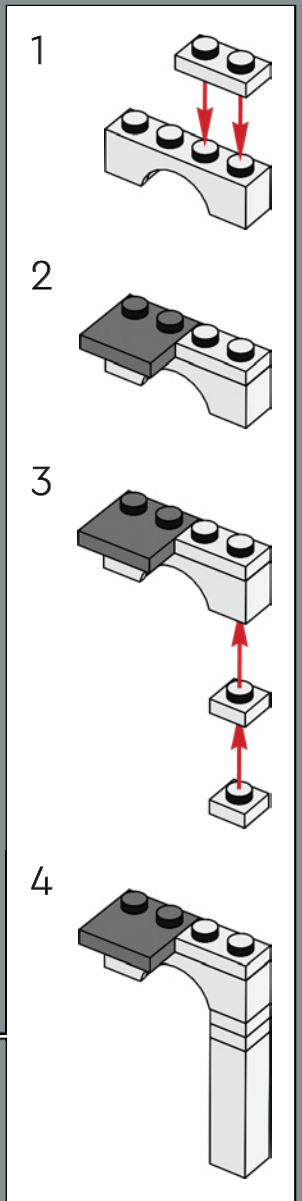
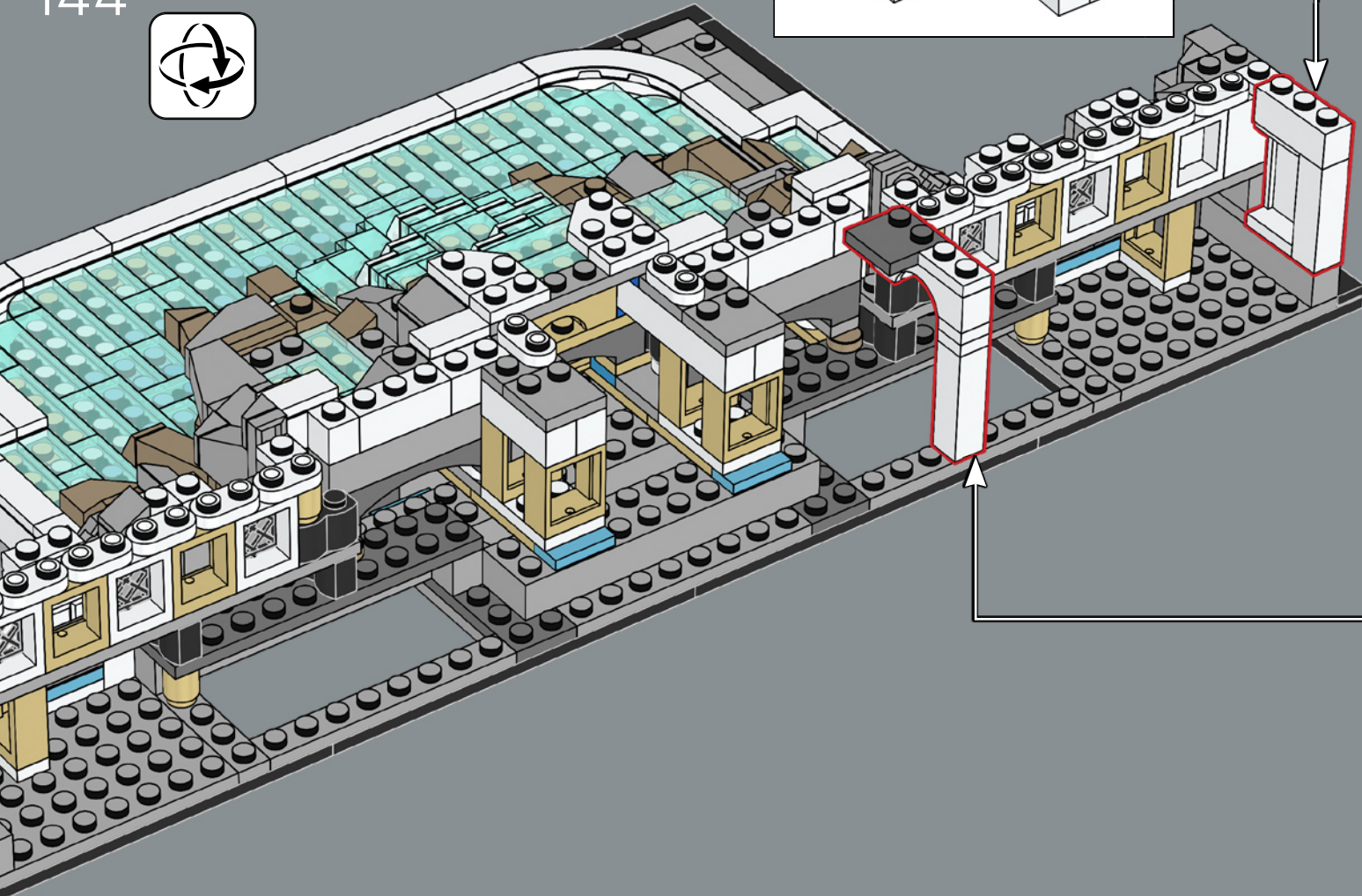
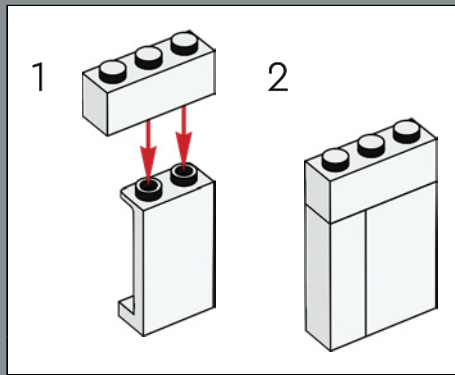

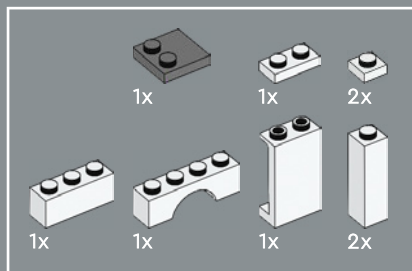

145

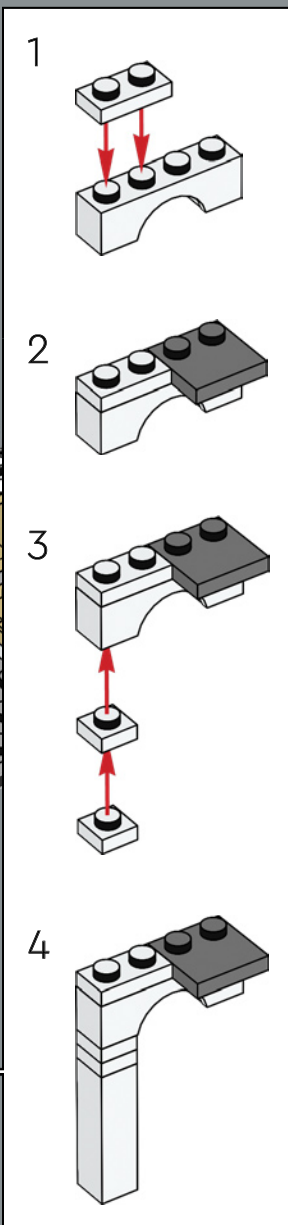
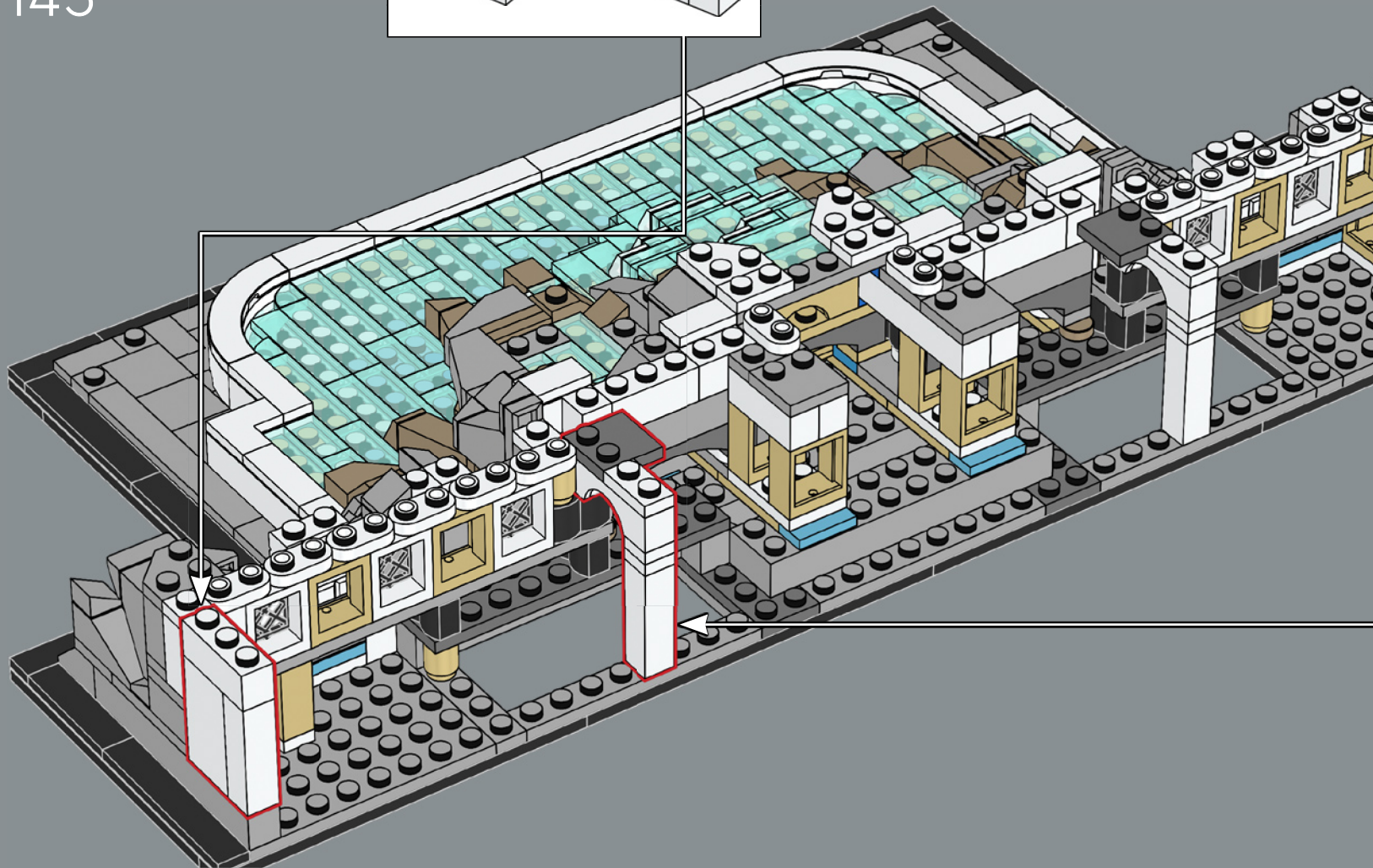
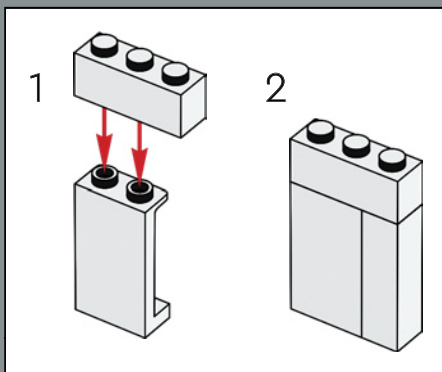

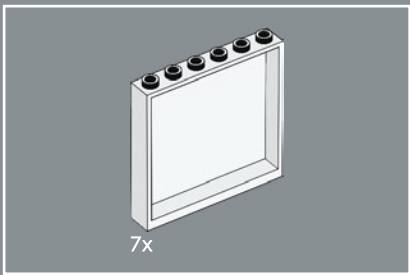

146

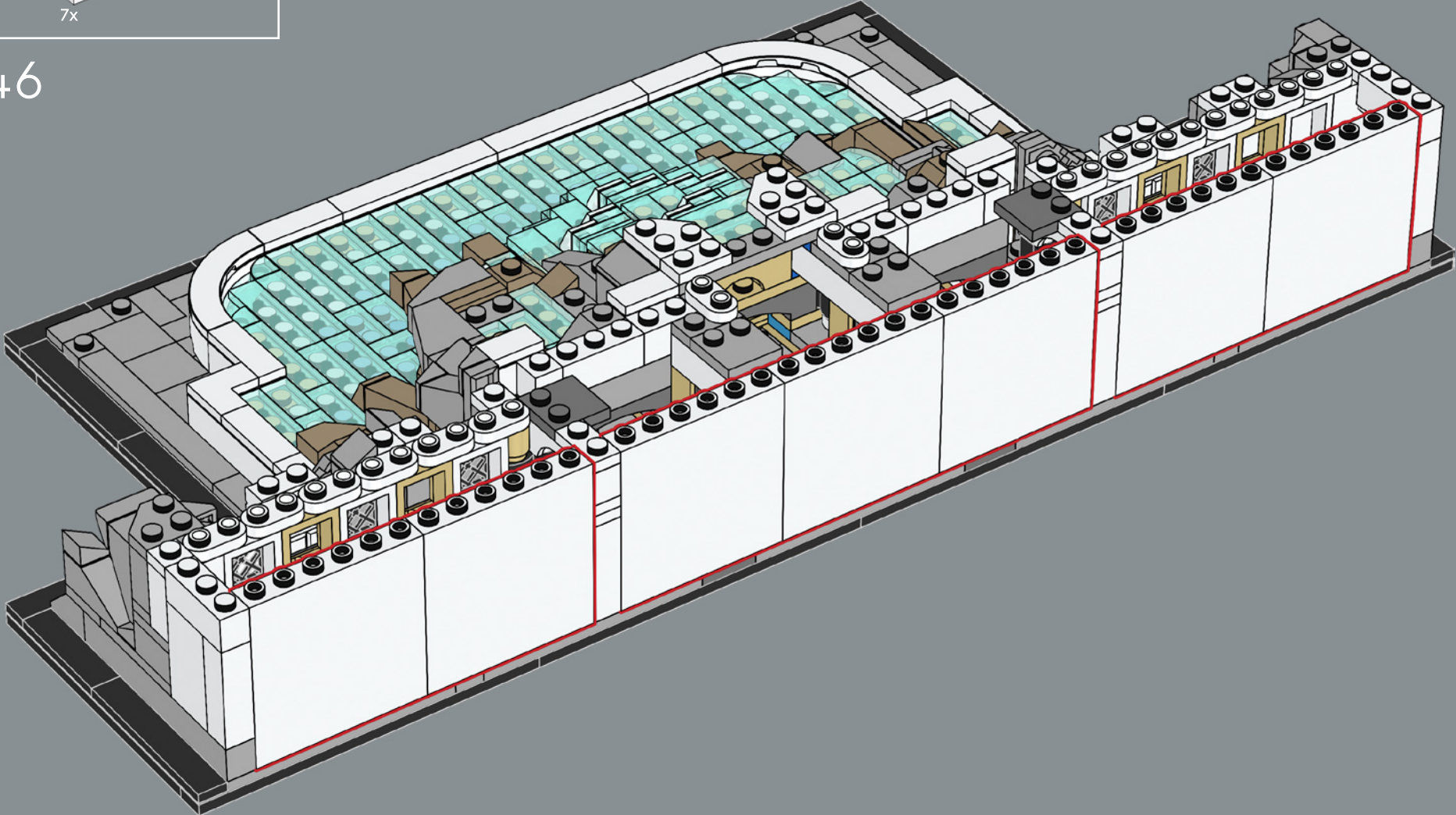

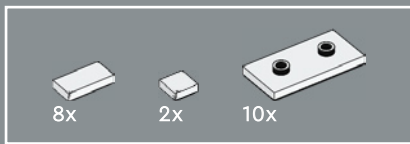

147

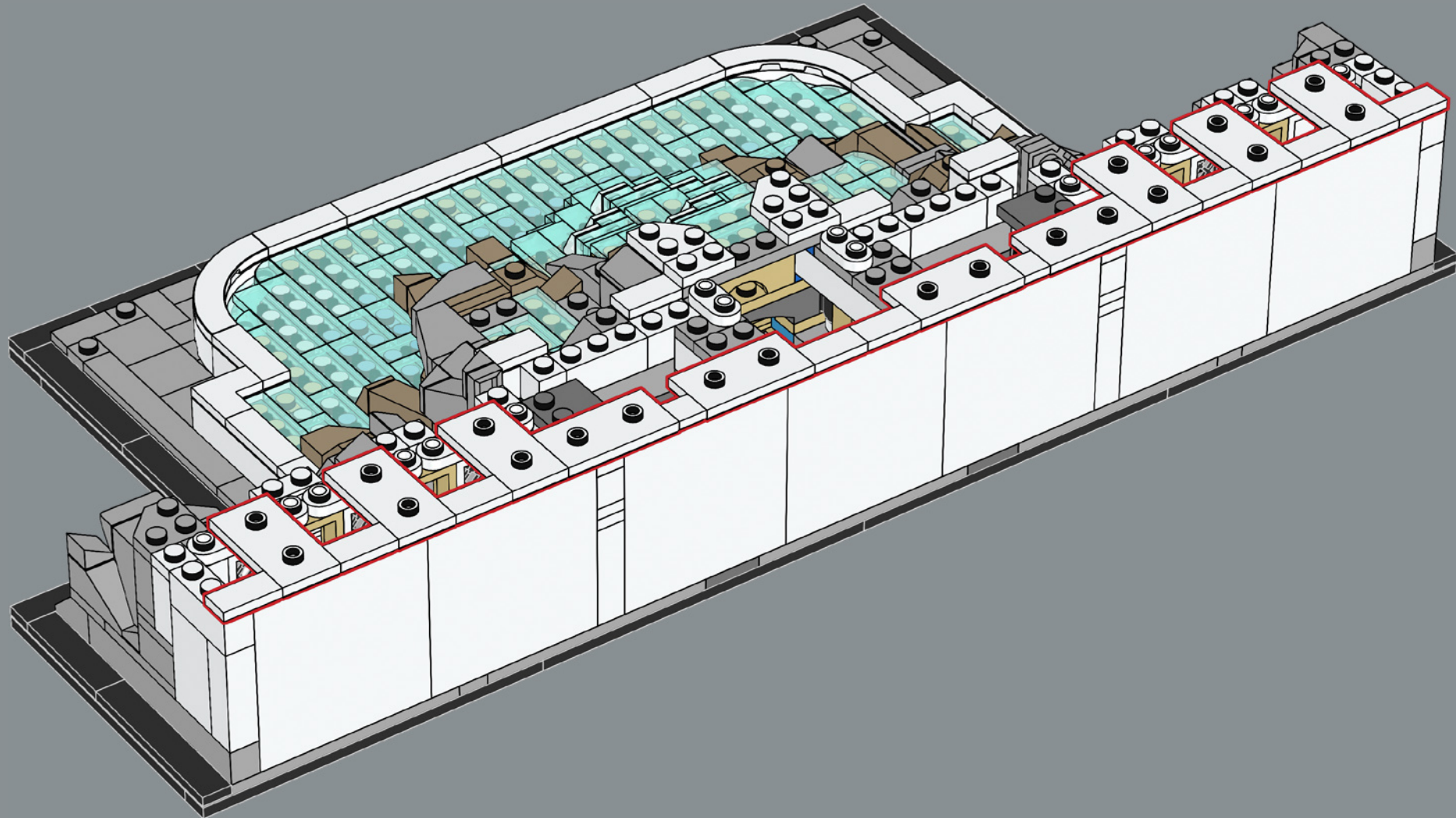

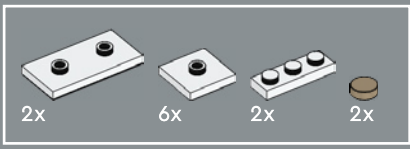

148

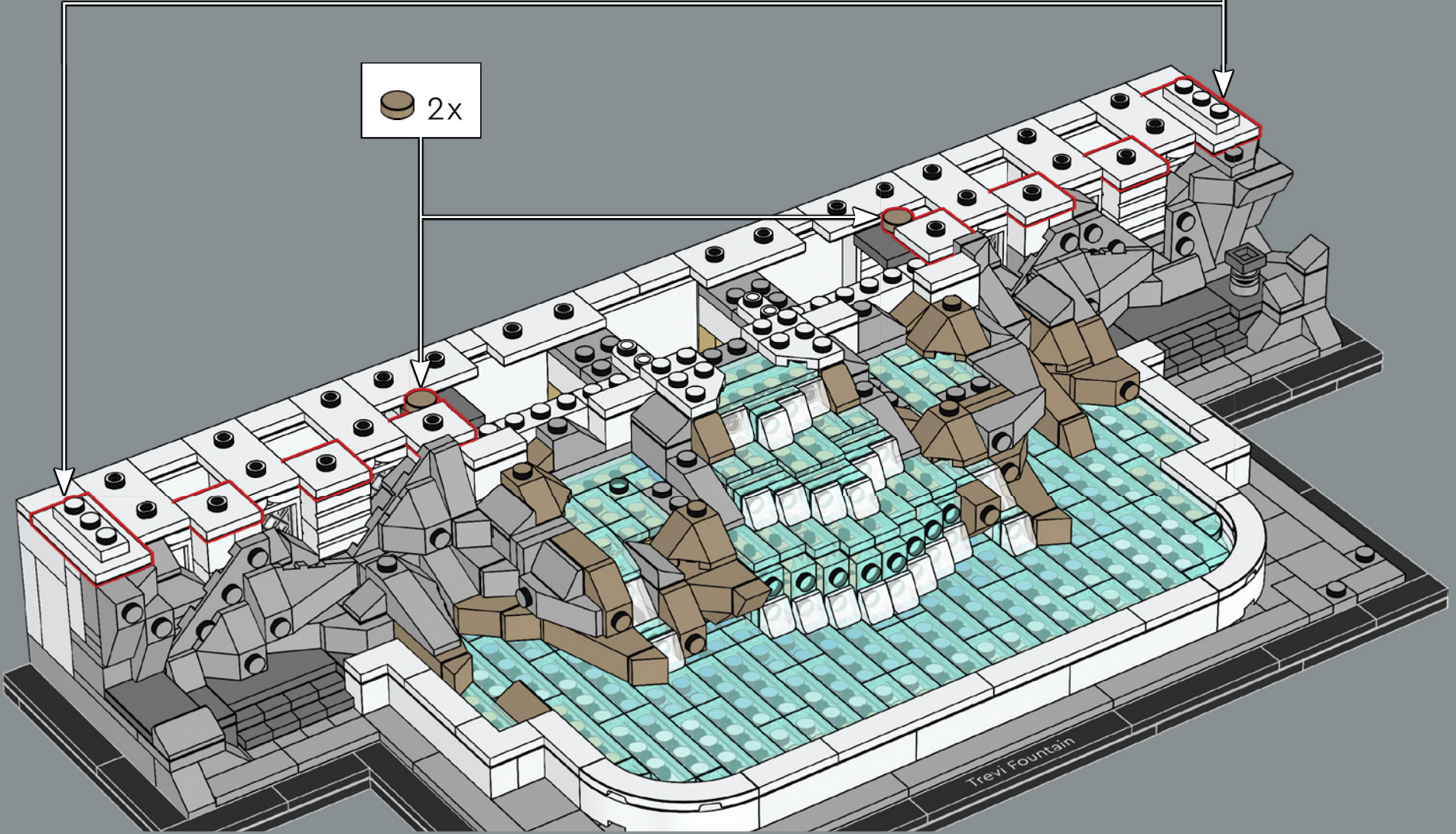
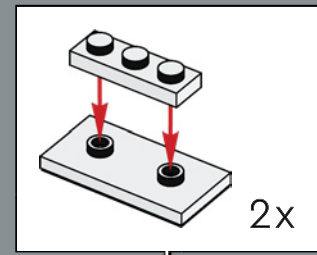



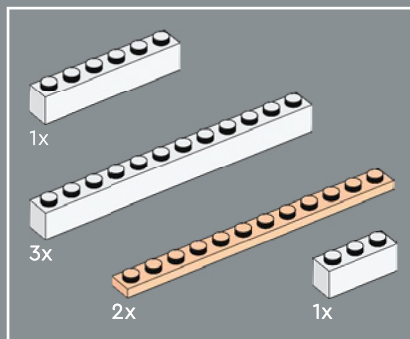

Para reproducir correctamente los detalles y la disposición espacial de los salientes y las secciones adelantadas respecto al resto de la fachada, alternamos entre la cuadrícula LEGO® estándar y otra desplazada ½ placa. Esto nos ayudó a dar fluidez al proceso de construcción y a crear un modelo sólido.

149

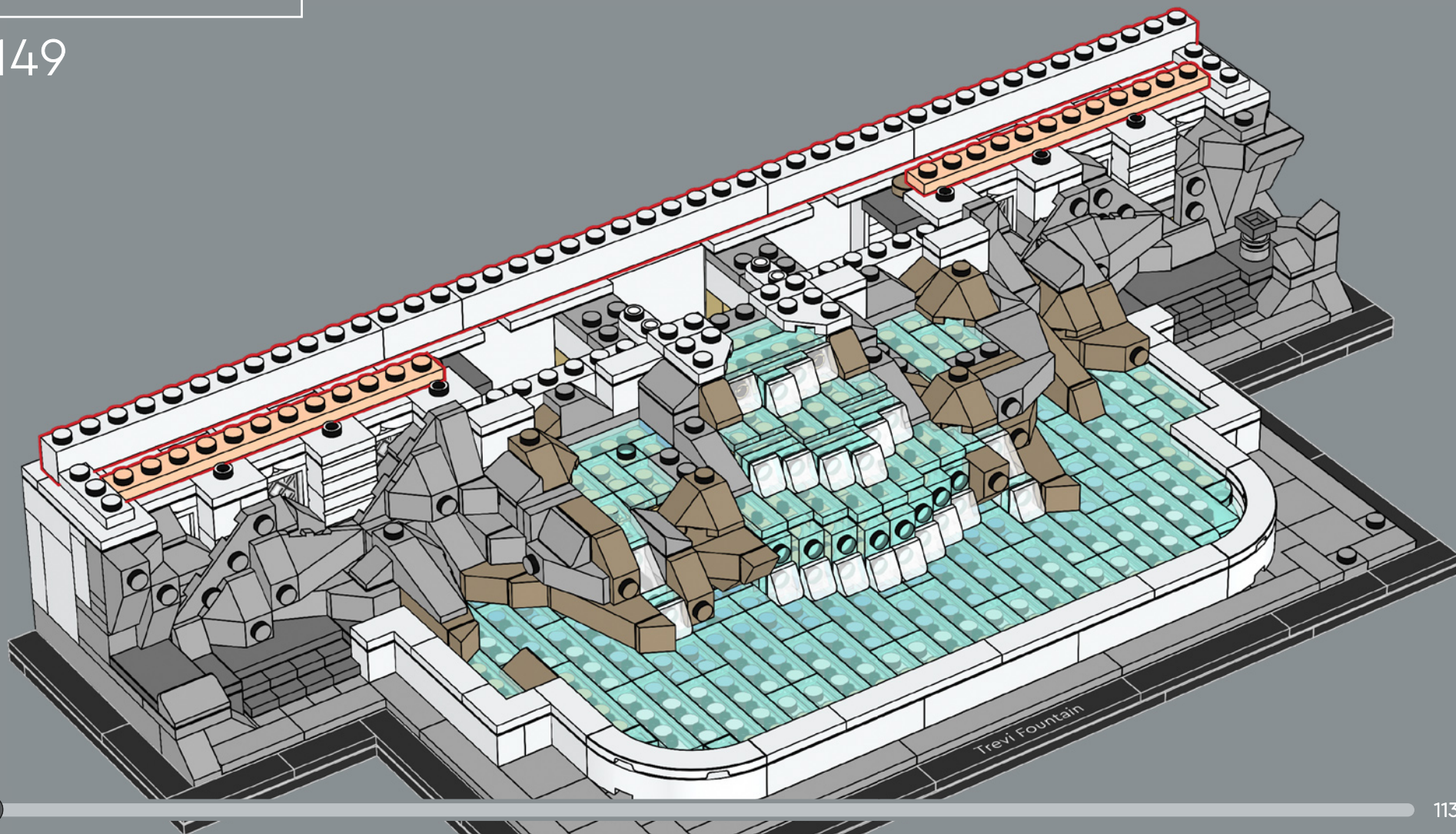



6x

150



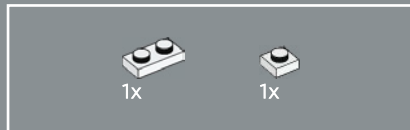
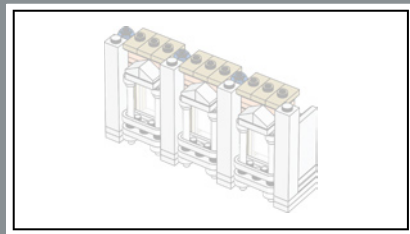

151

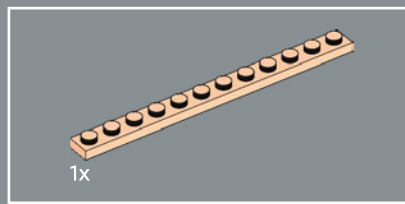
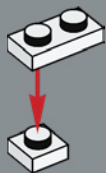

152

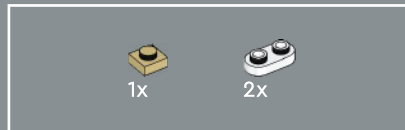
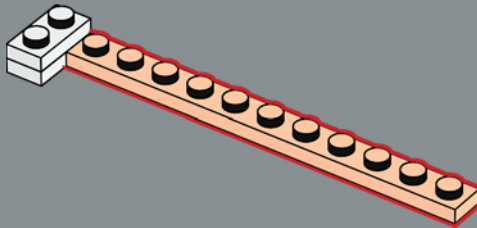

153

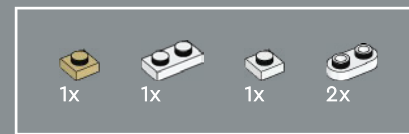
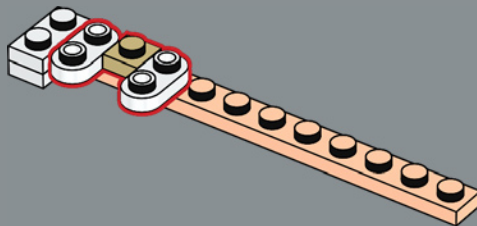

154

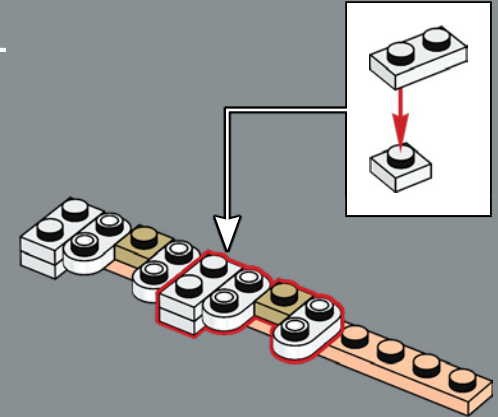

155

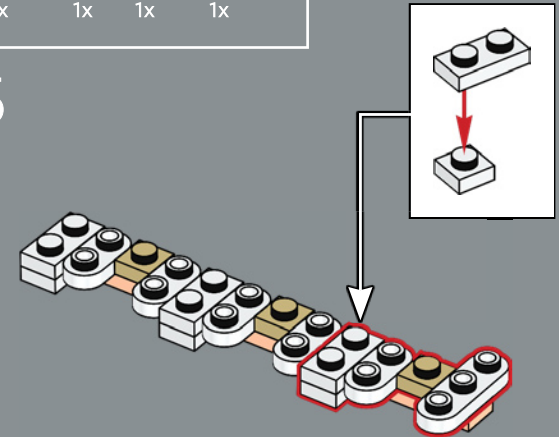

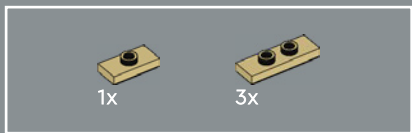

156

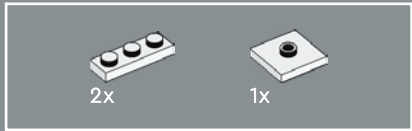
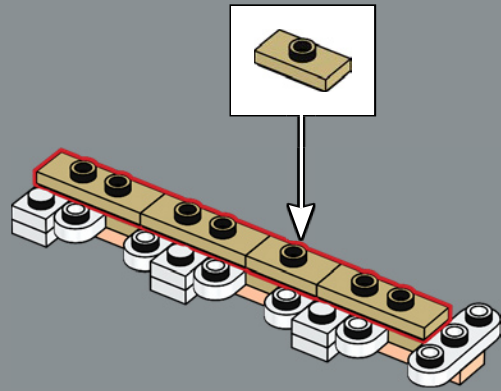

157

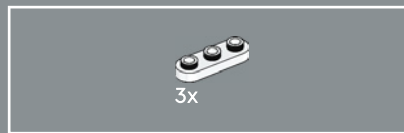
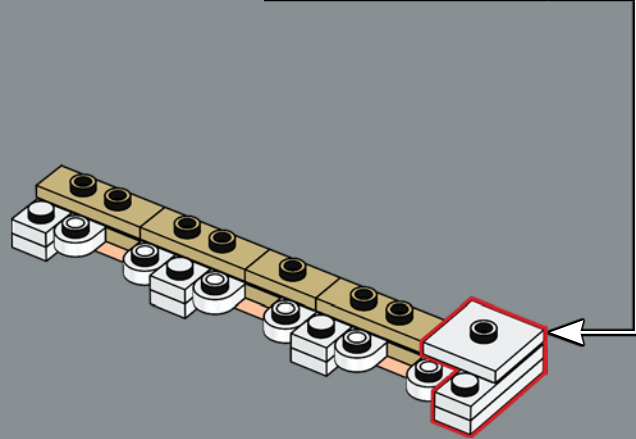
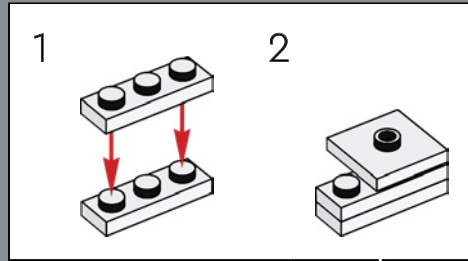

158

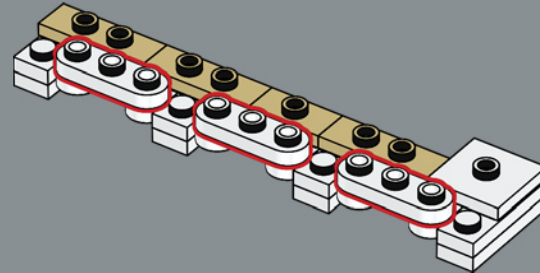

159

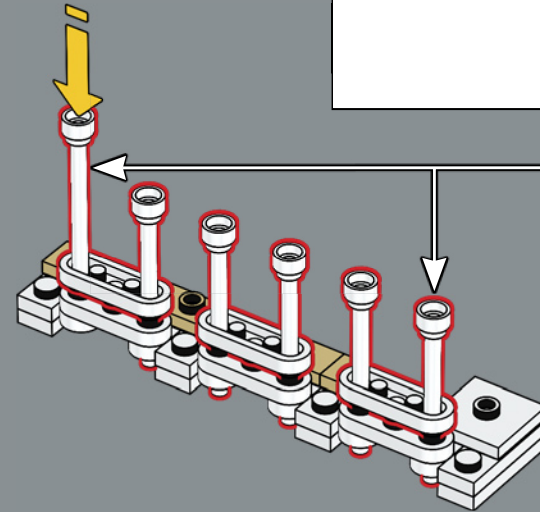
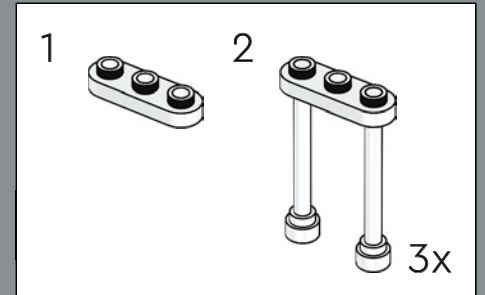

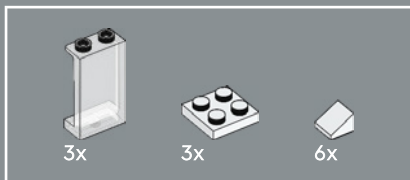

160

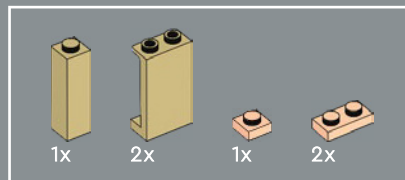
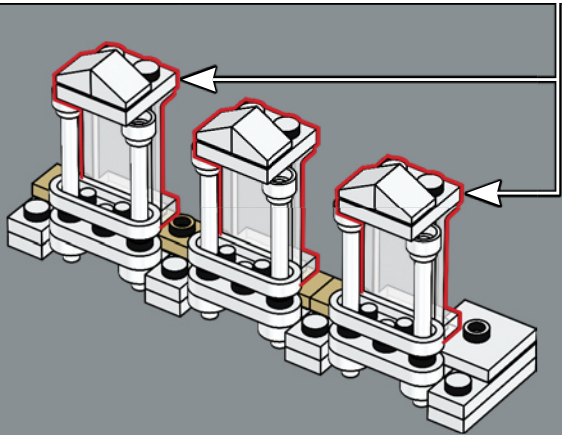
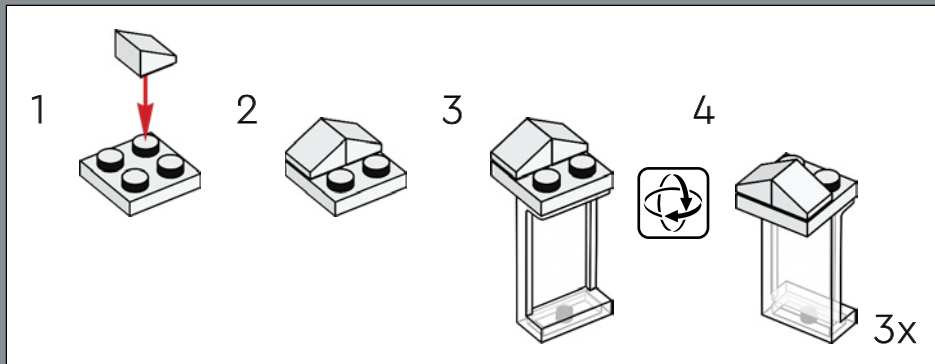
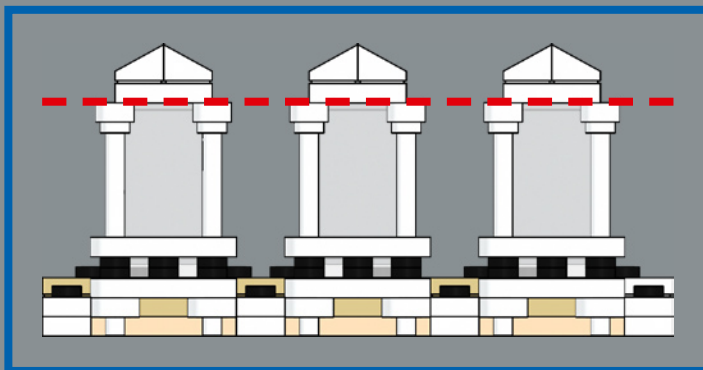

161

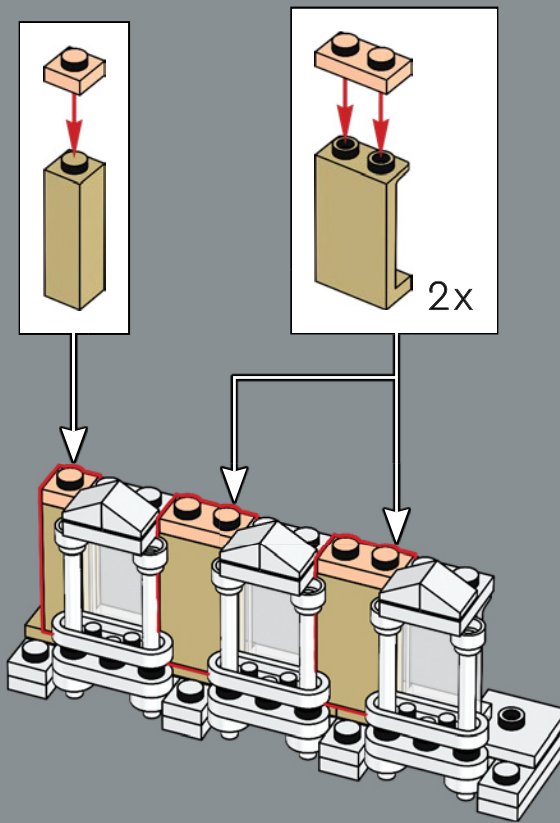

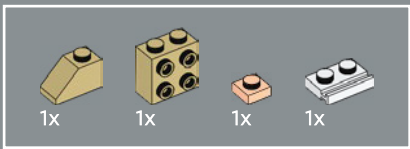

162

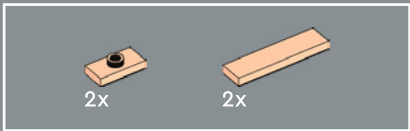
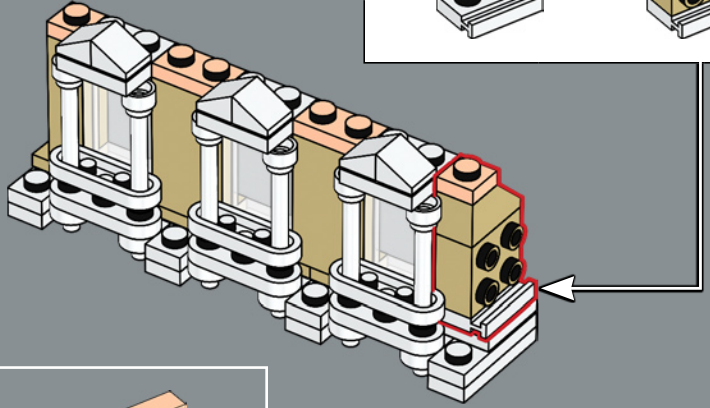
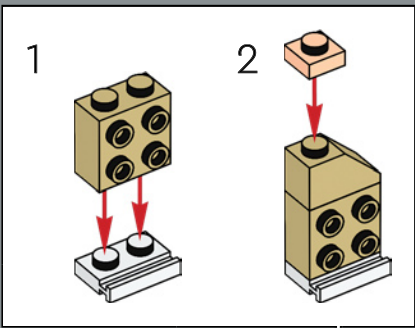

163

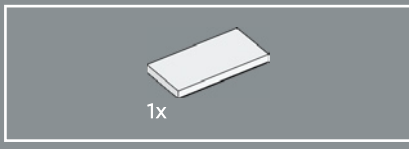
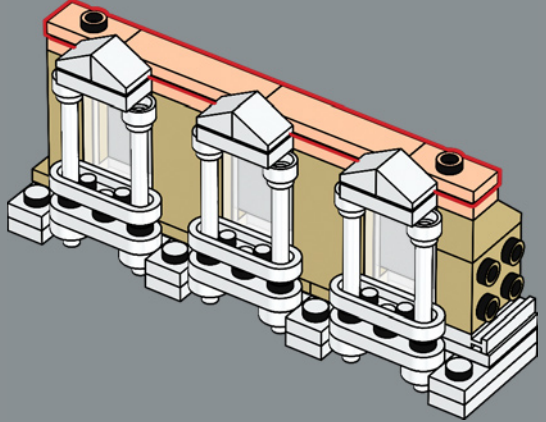

164

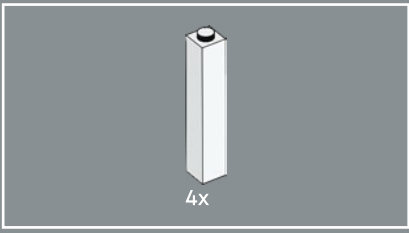
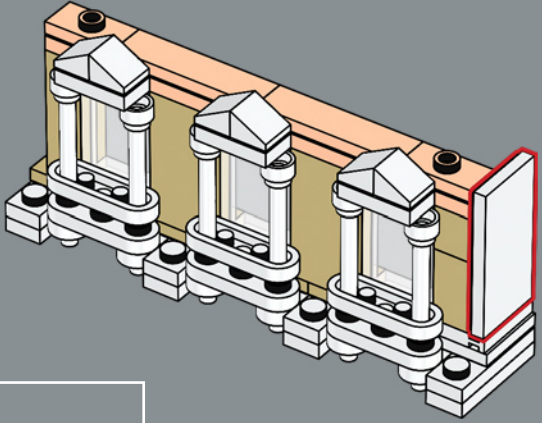

165

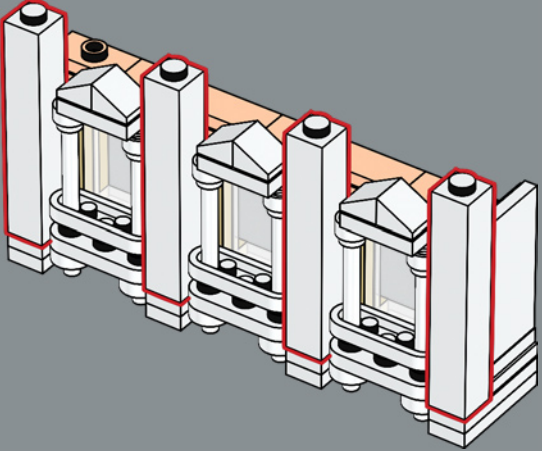

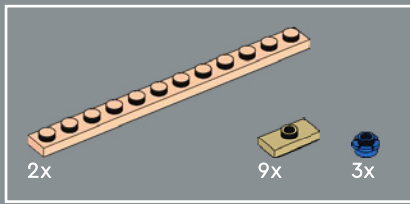

166

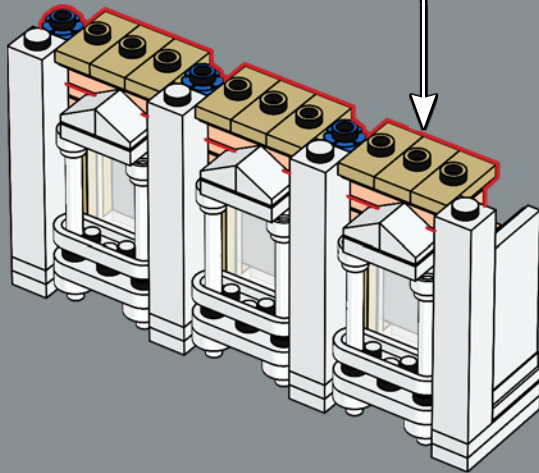
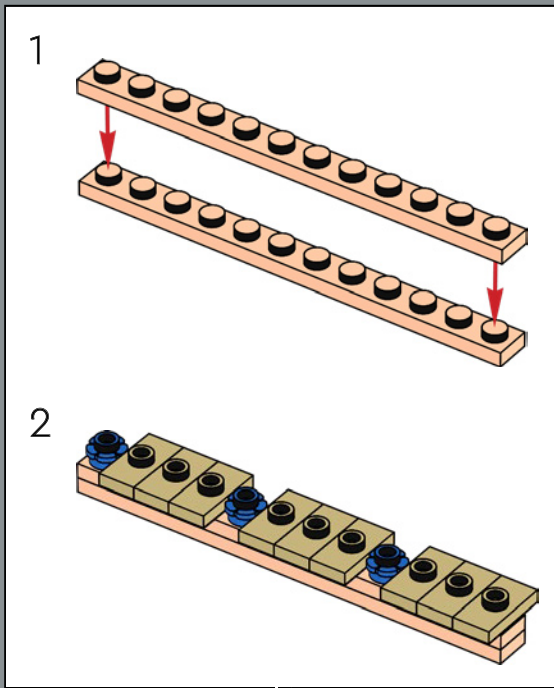

167

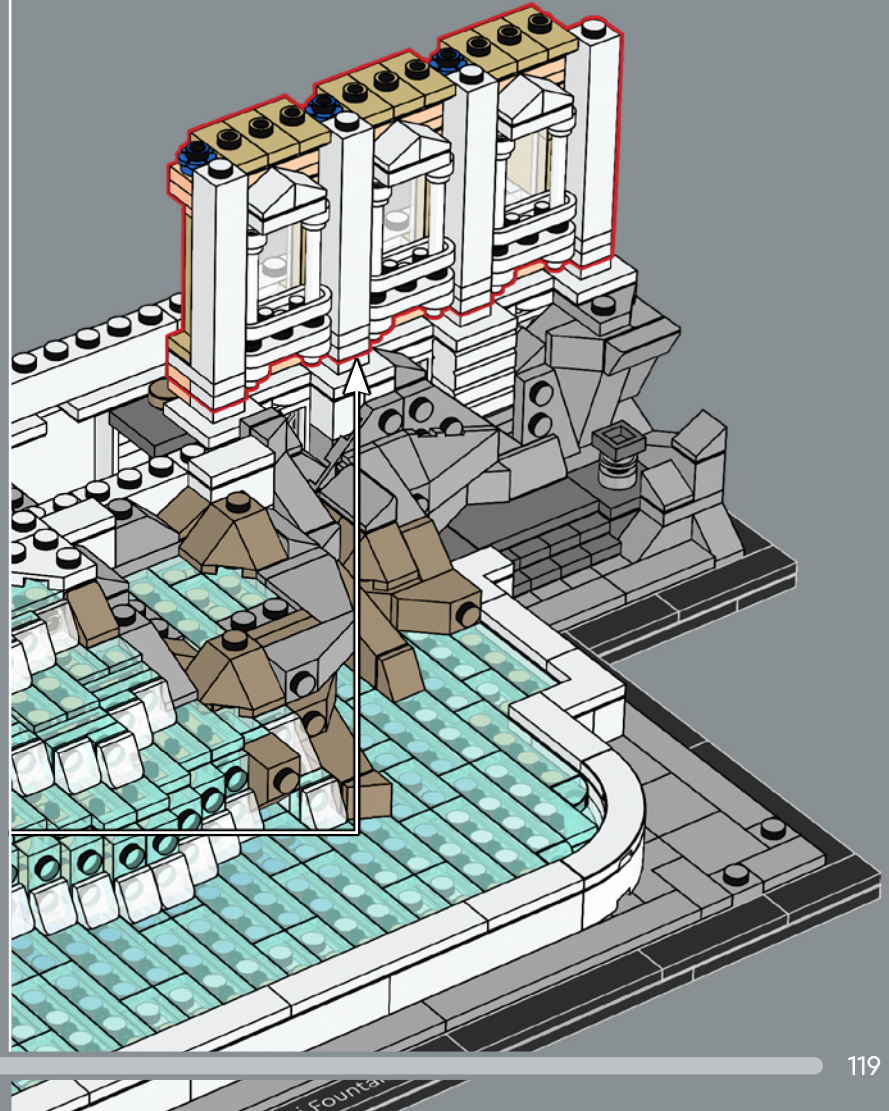

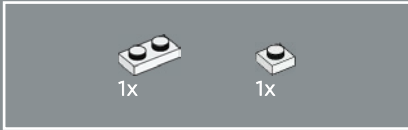
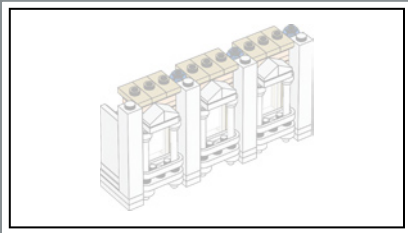

168

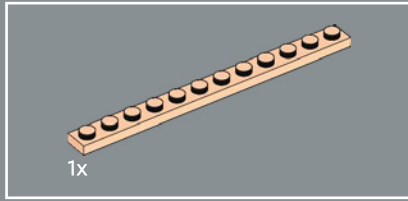
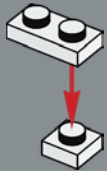

169

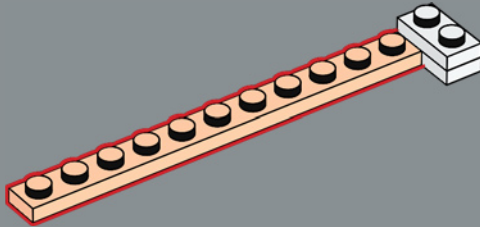

170

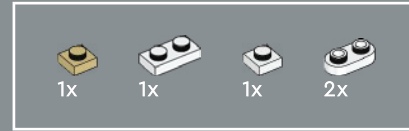
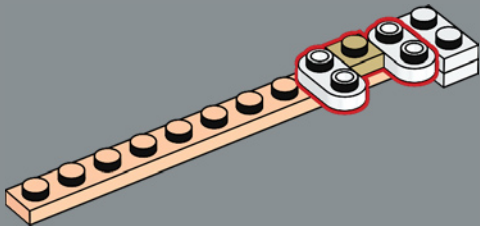

171

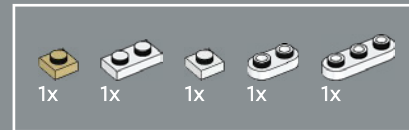
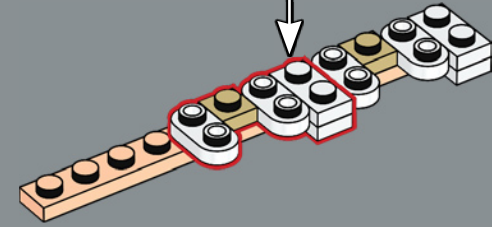
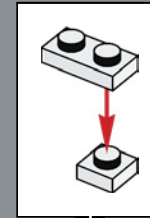

172

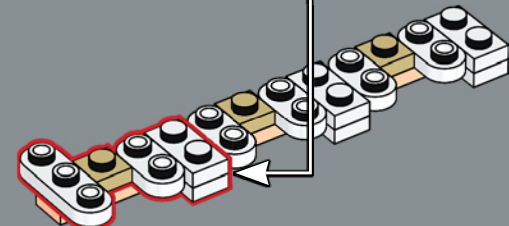
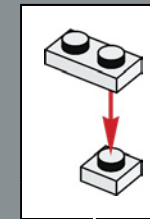



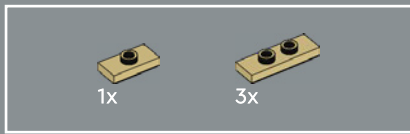

173

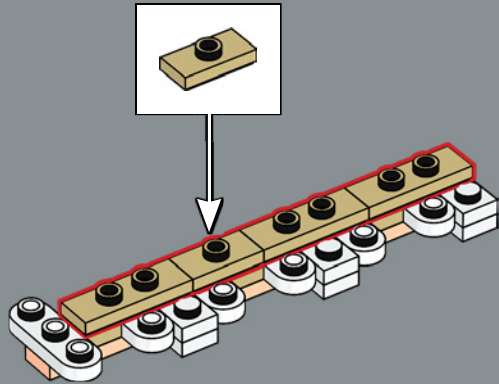

174

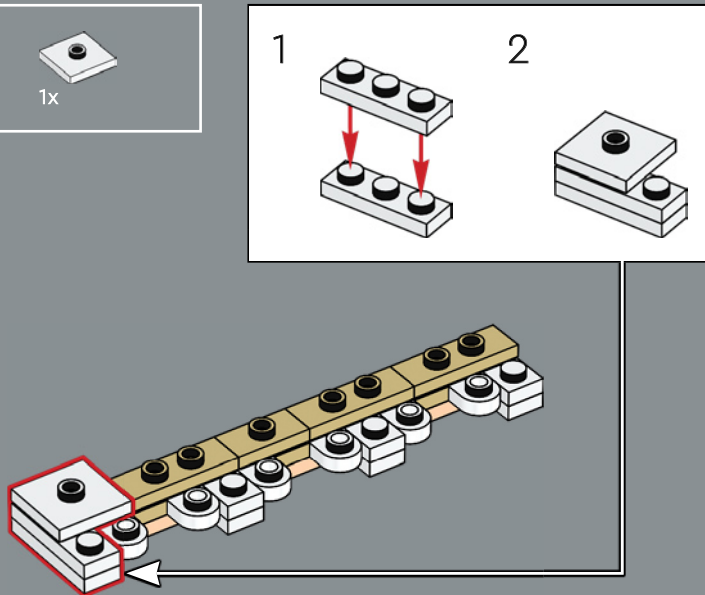

175

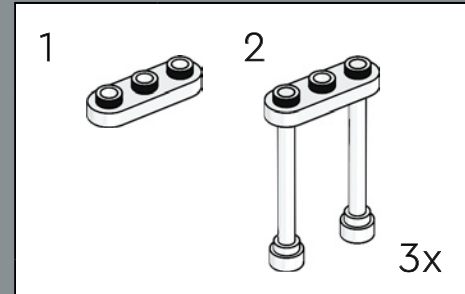
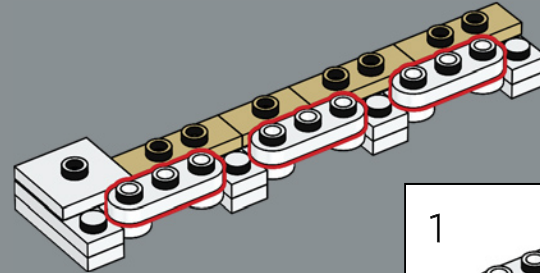

176

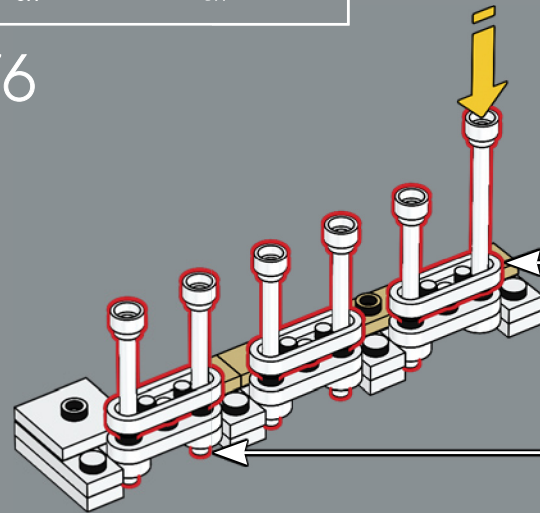

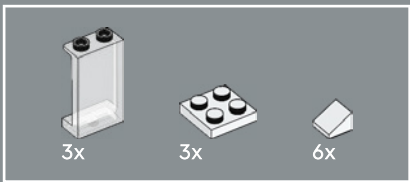

177

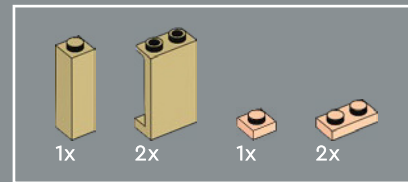
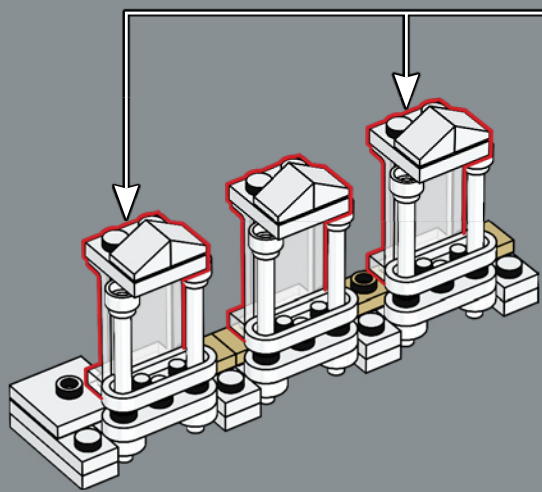
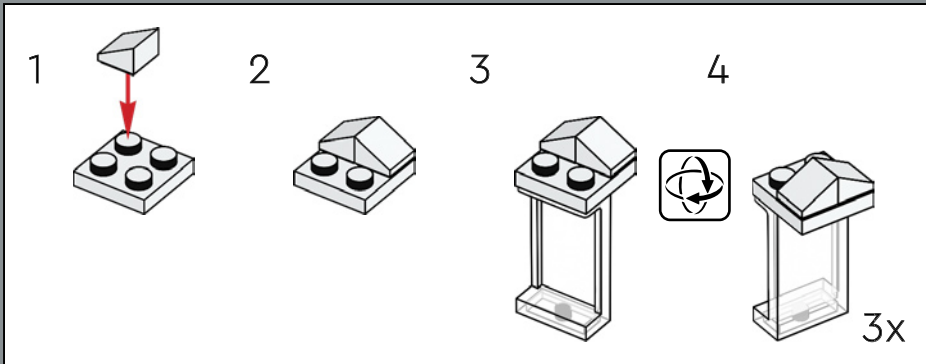
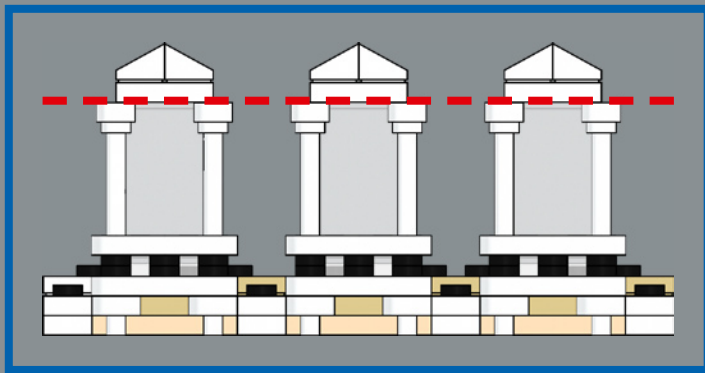

178

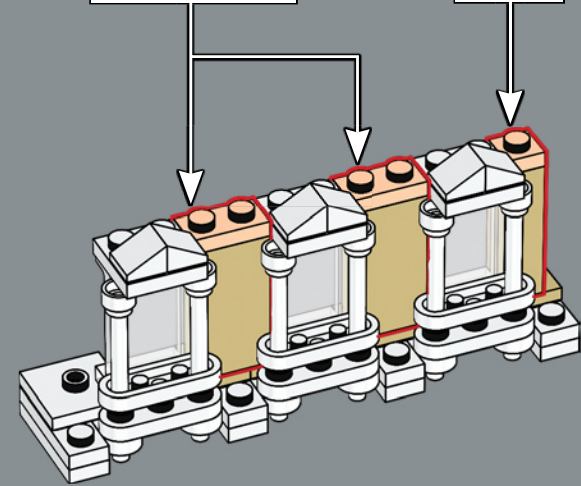
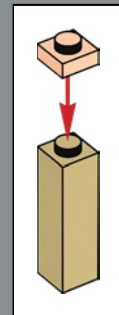
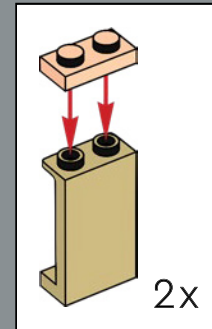

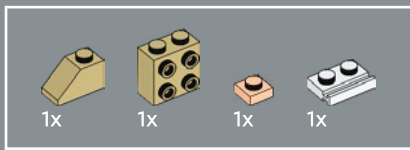

179

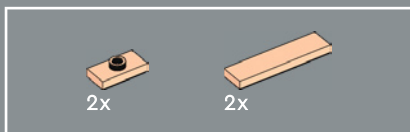
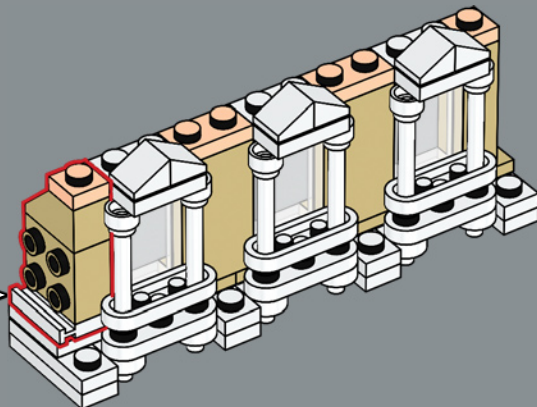
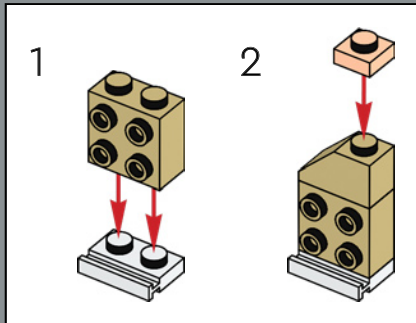

180

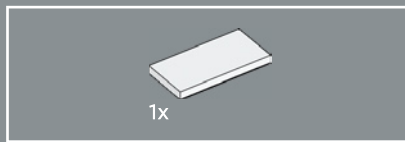
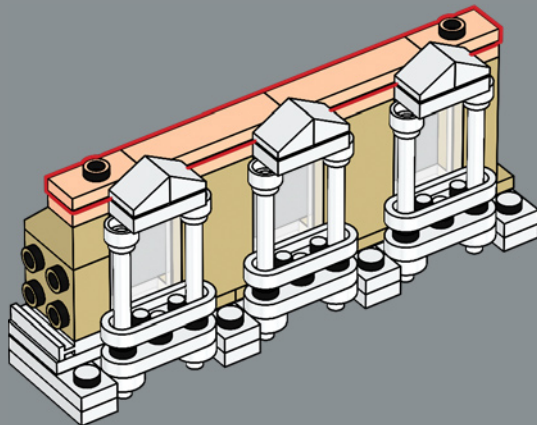

181

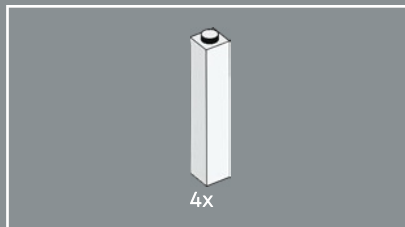
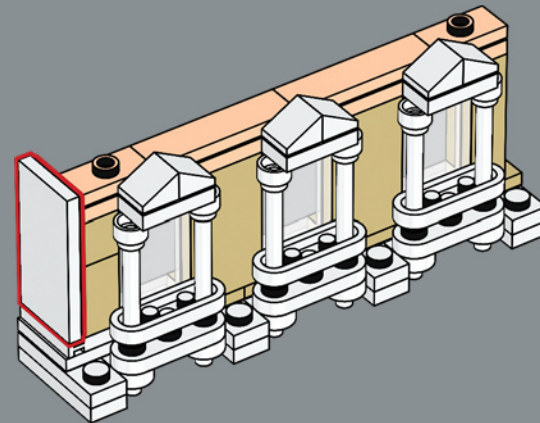

182

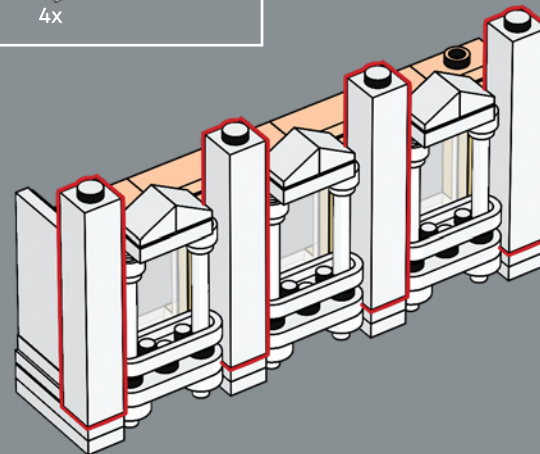

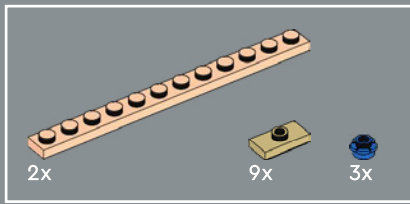

183

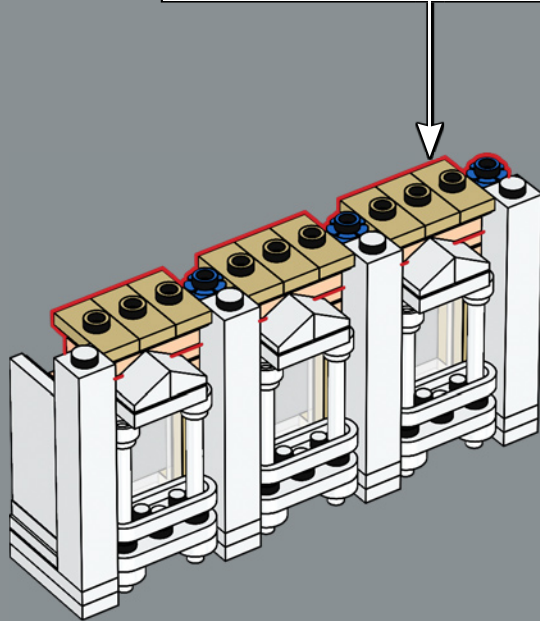
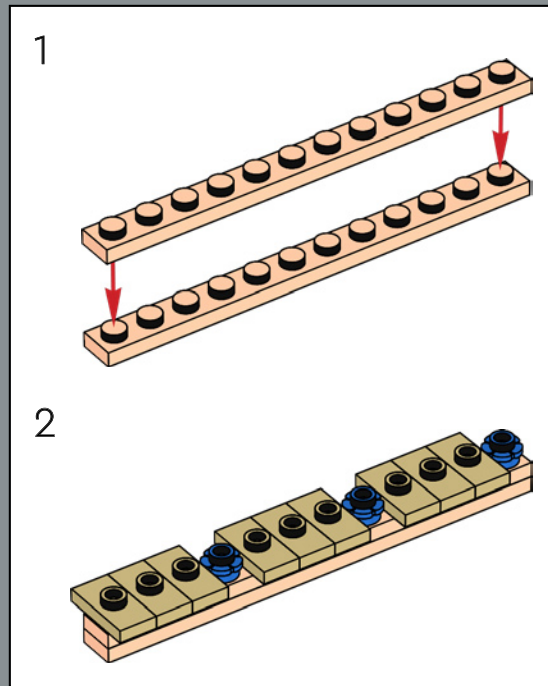

184

El color arena se reserva para las áreas de la fuente más en sombra, debajo de los salientes y detrás de las molduras de las ventanas.

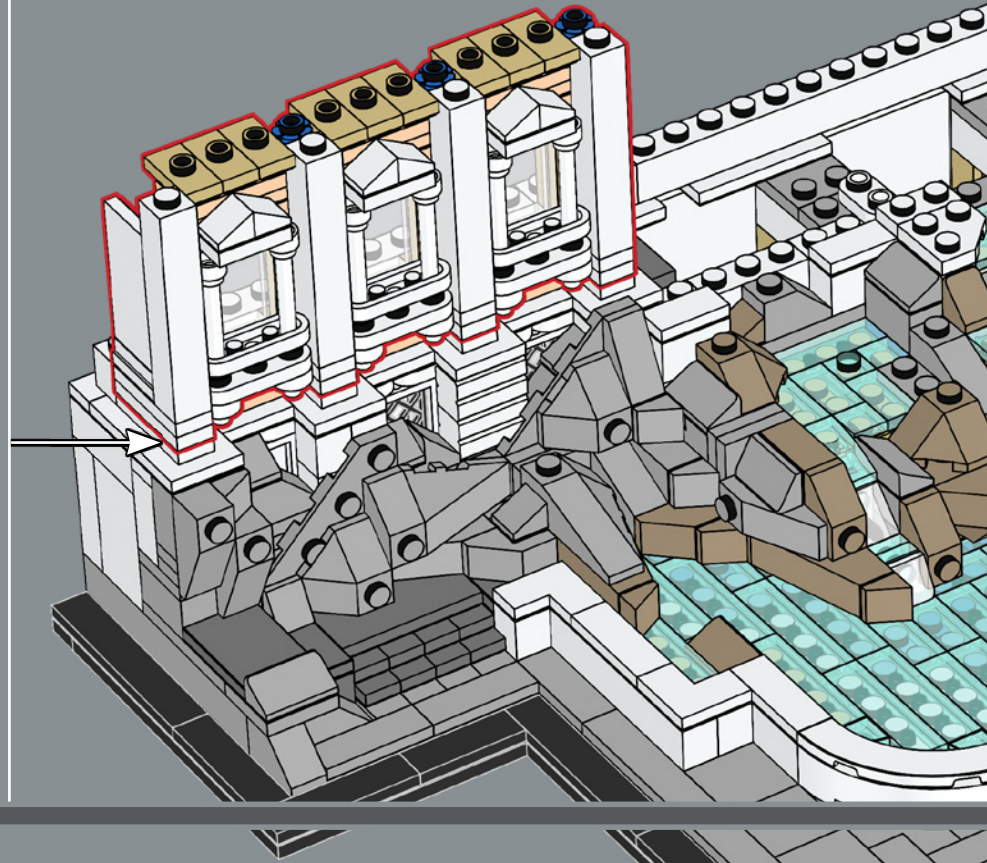

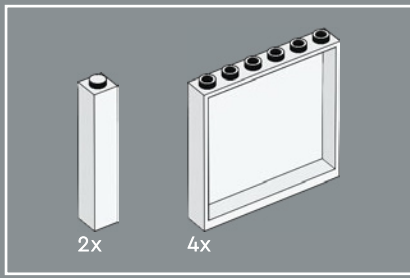

185

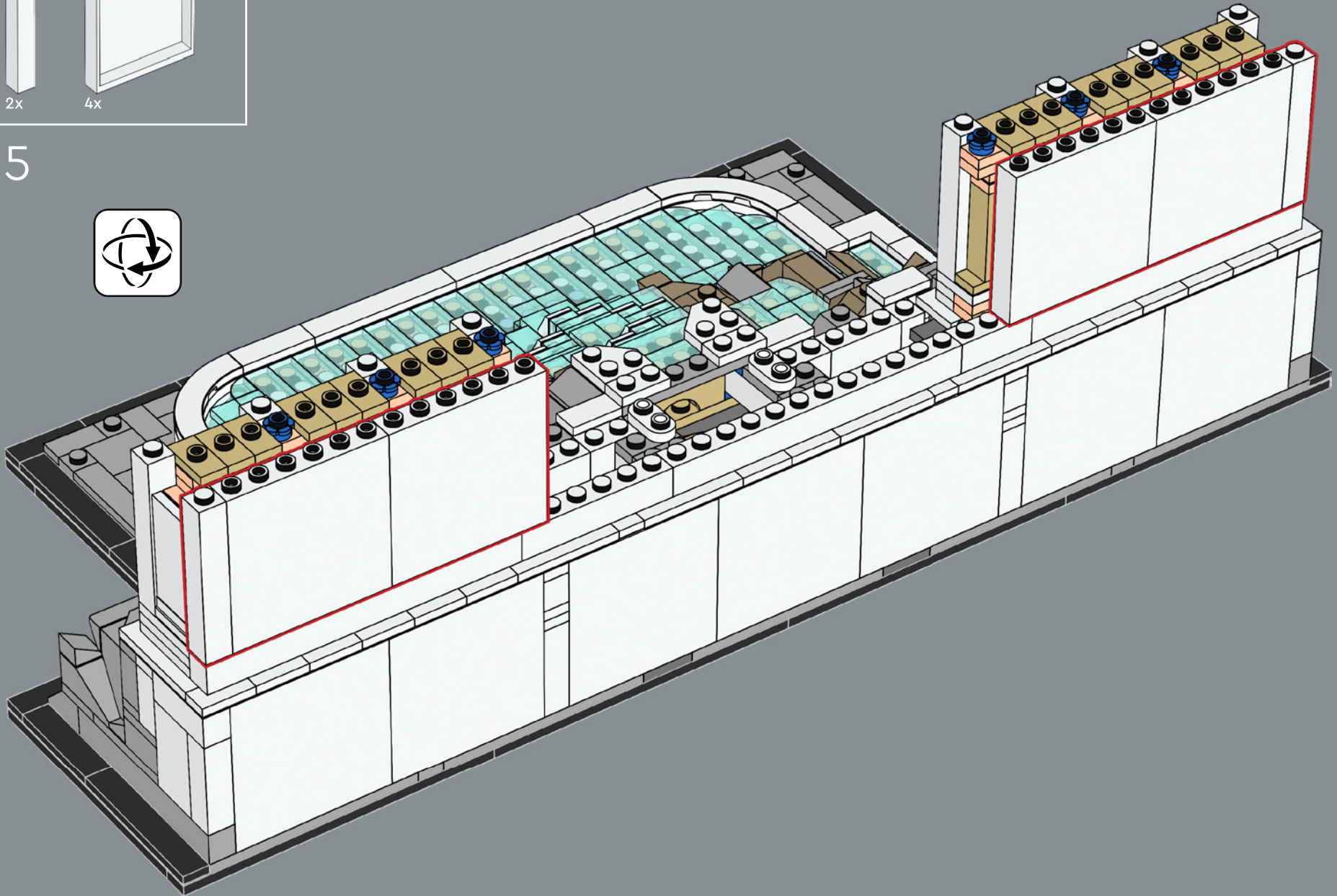

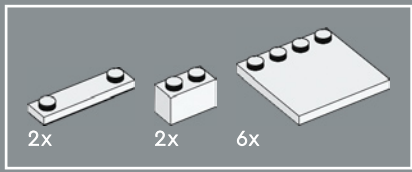

186

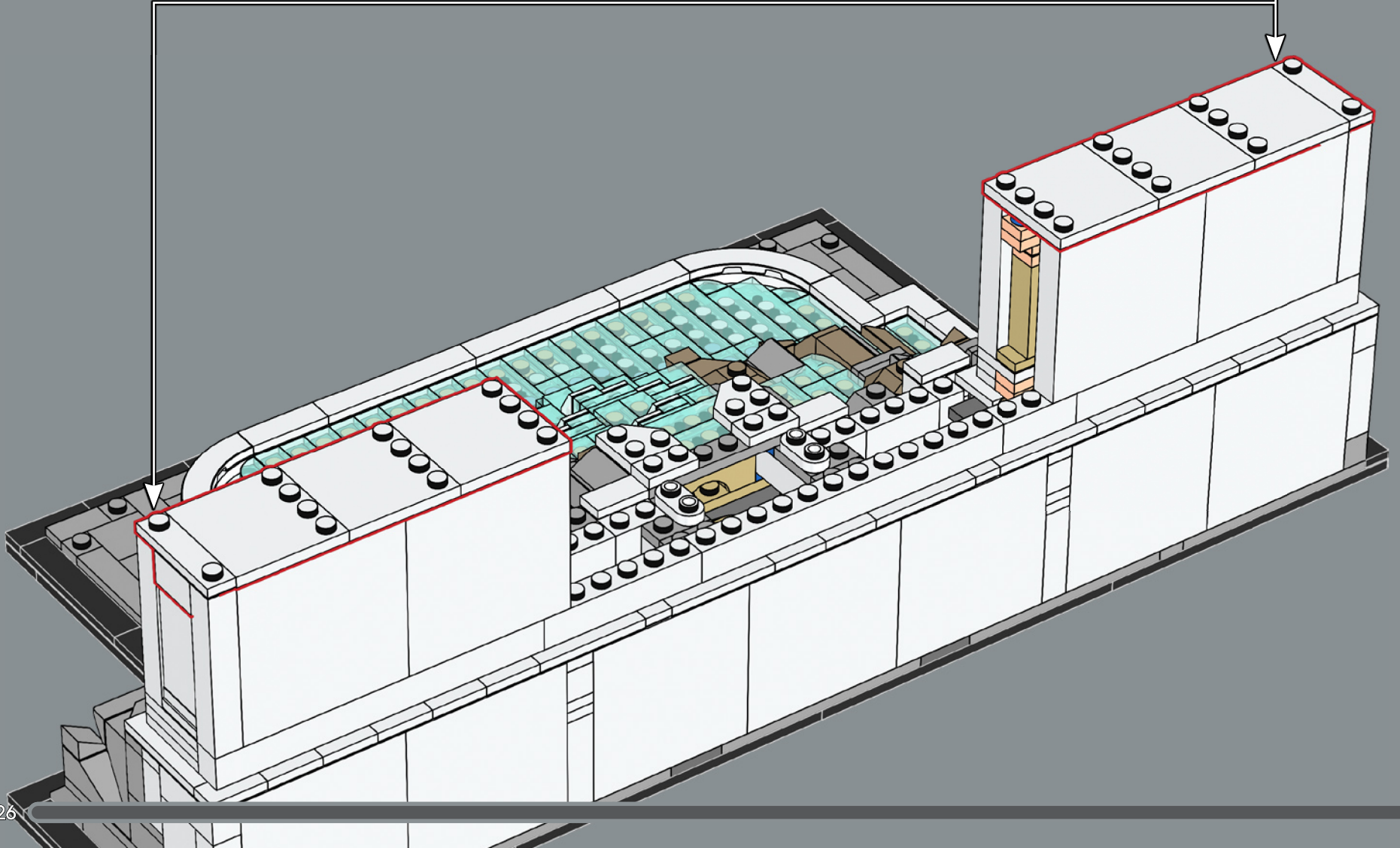
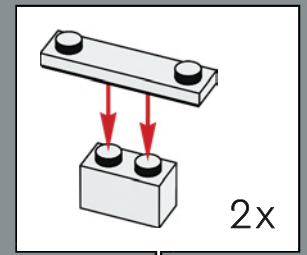

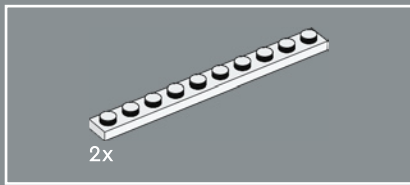

187

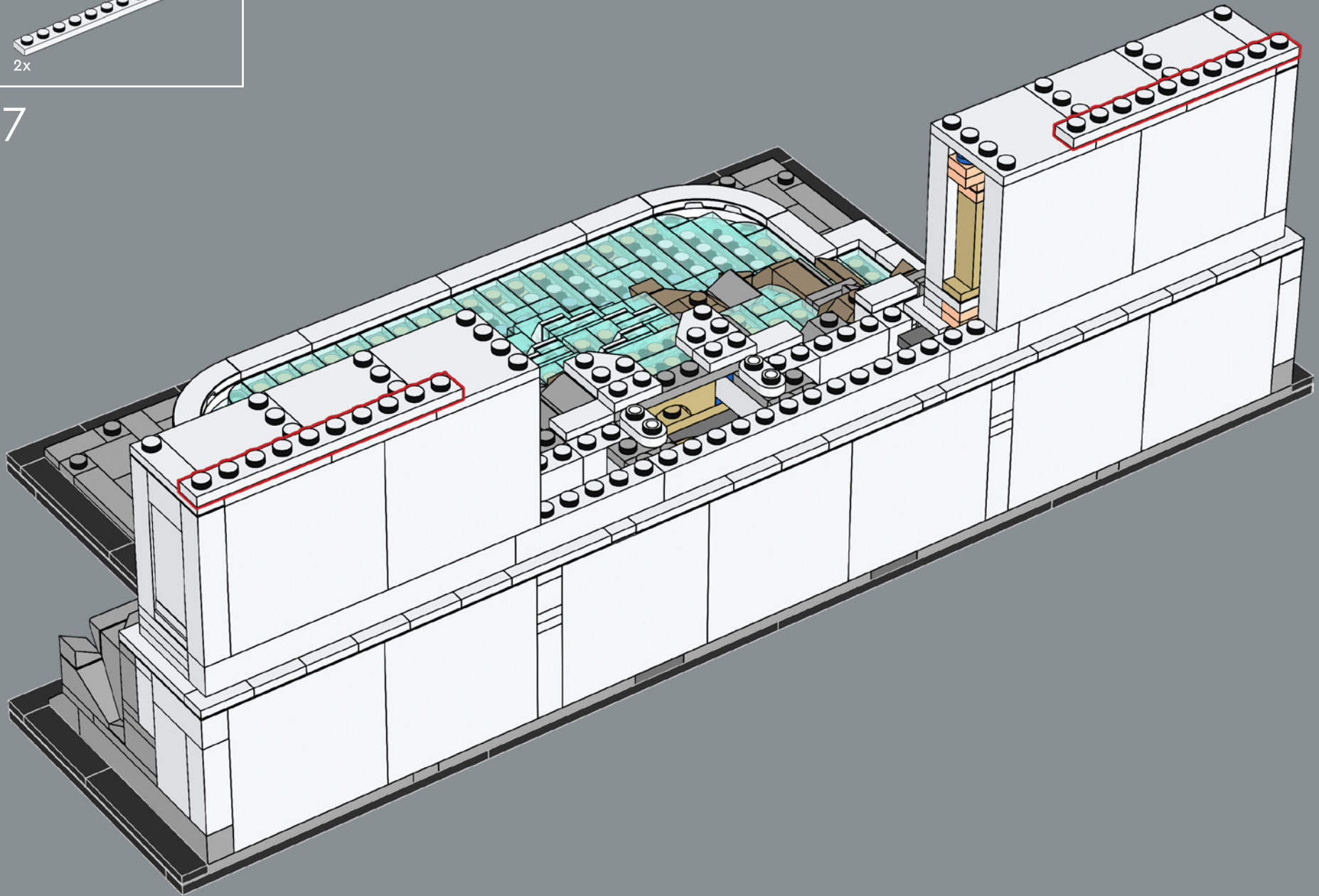

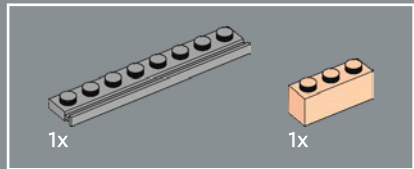
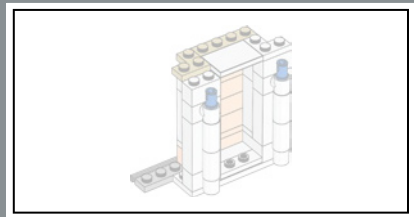

188

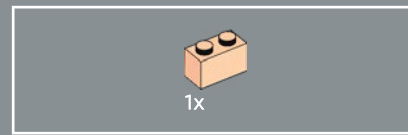
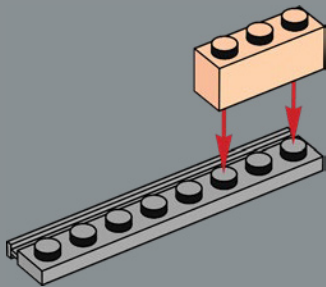

189

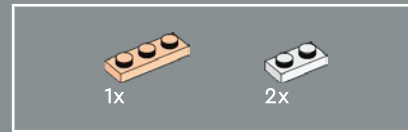
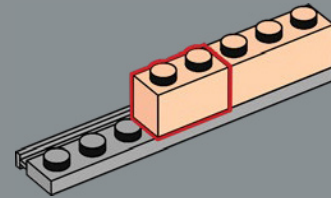

190

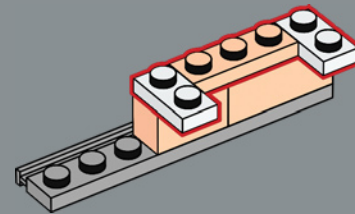



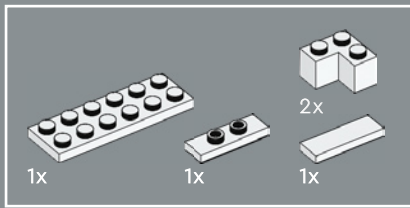

191

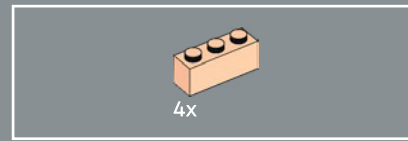
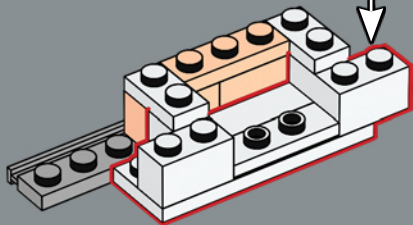
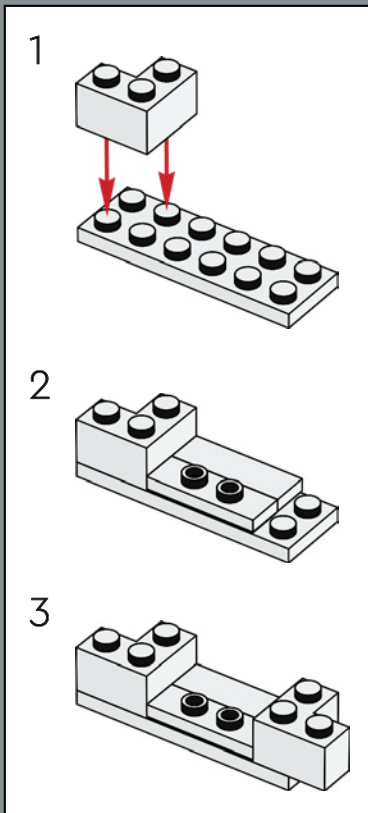

192

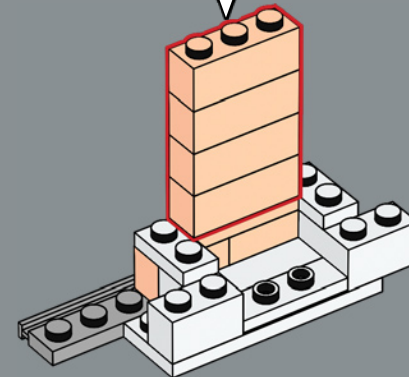
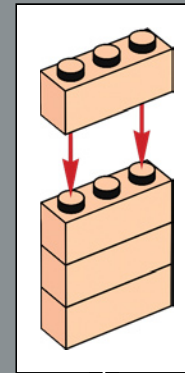

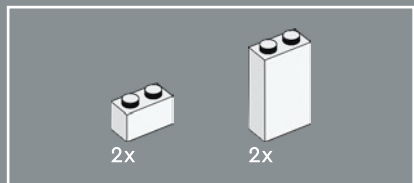

193

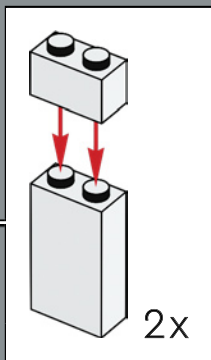
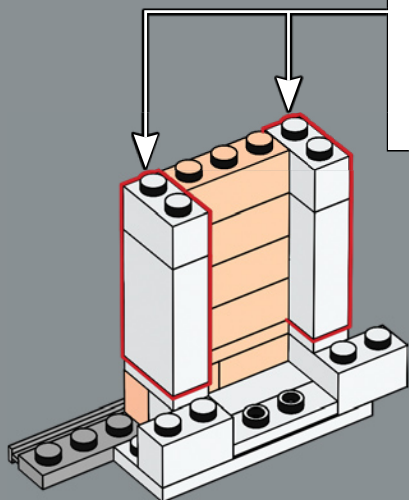

2x

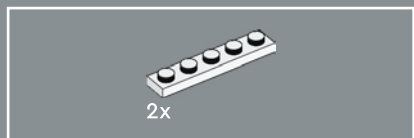

194

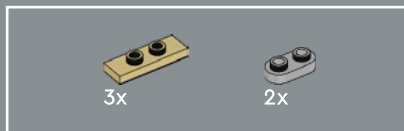
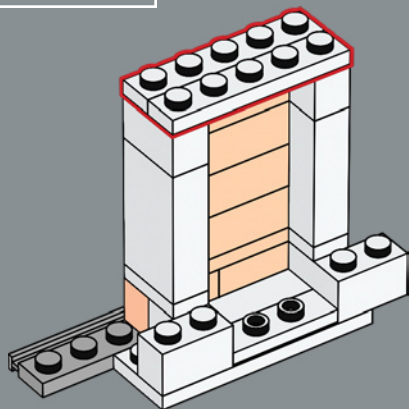

195

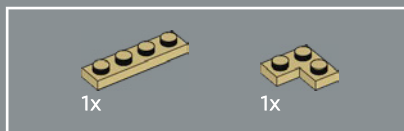
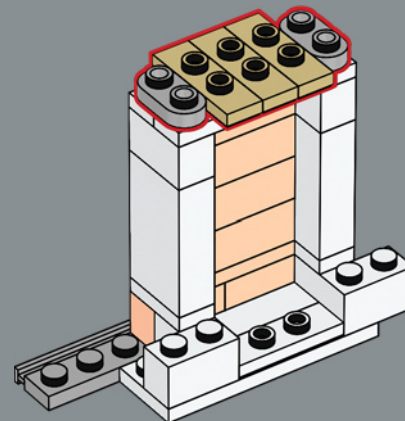

196

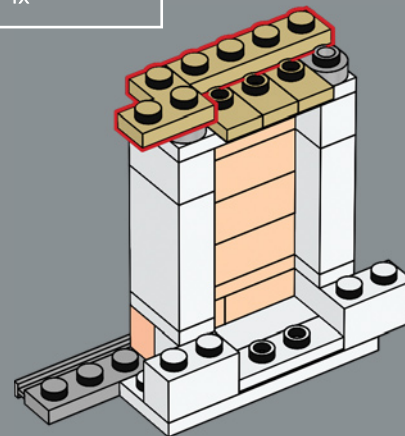

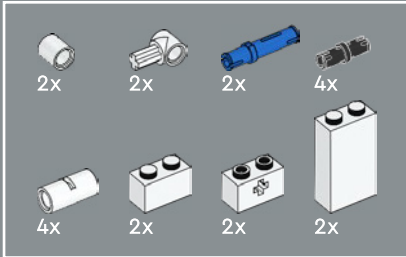
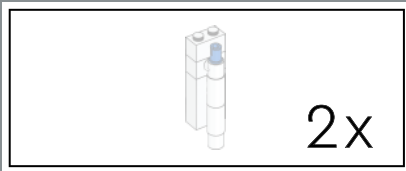

197

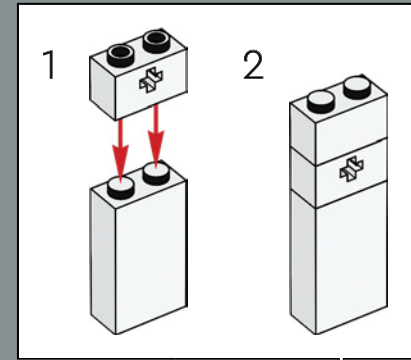
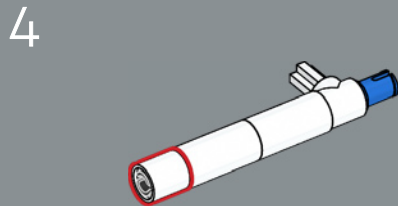
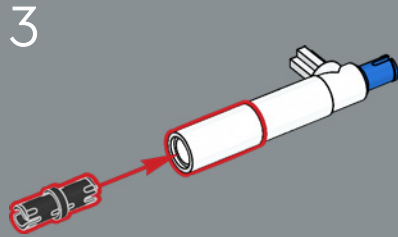
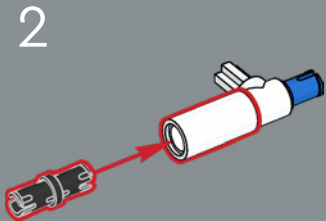
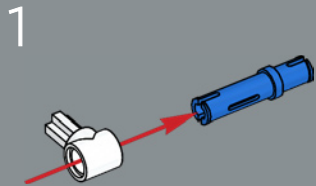

5

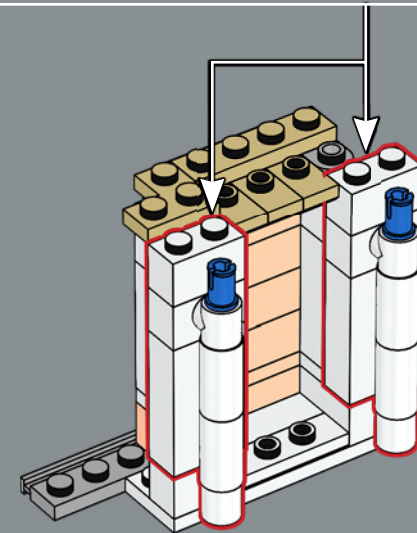
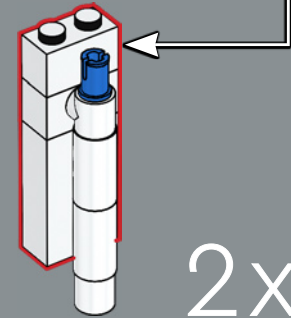

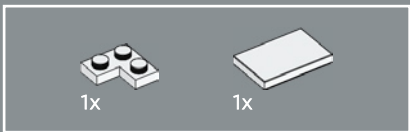

198

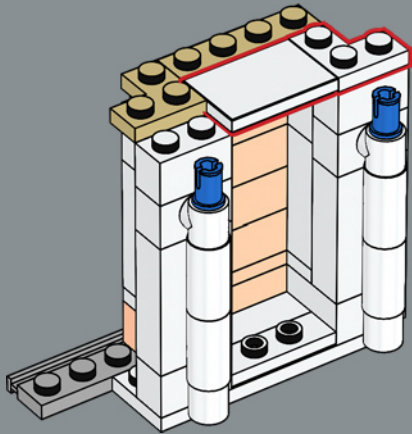

199

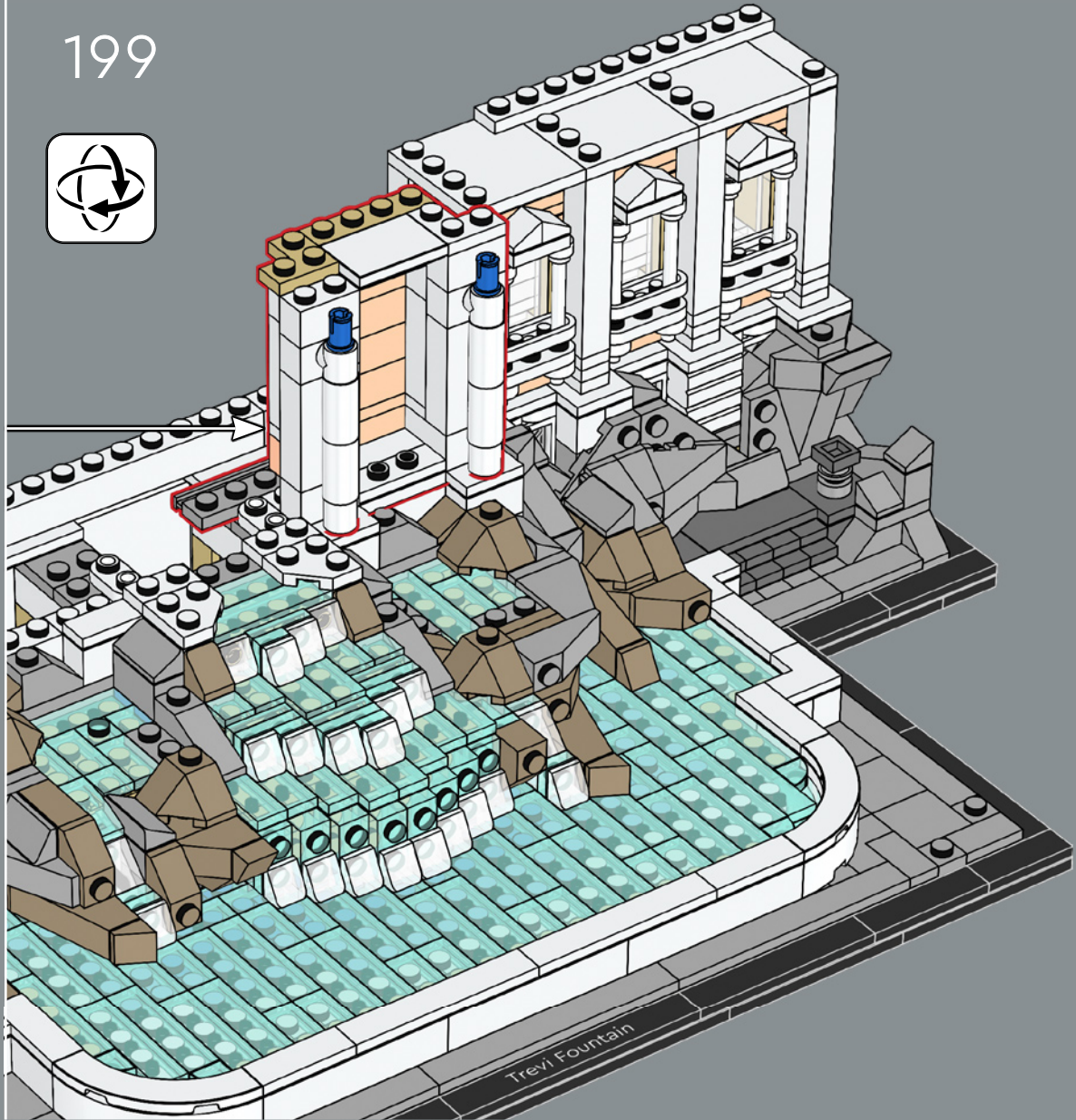

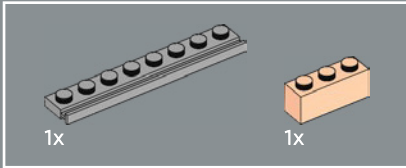
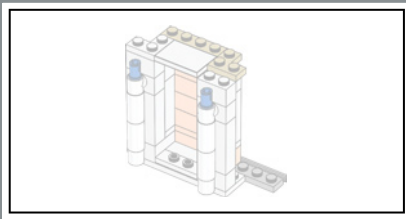

200

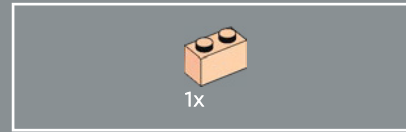
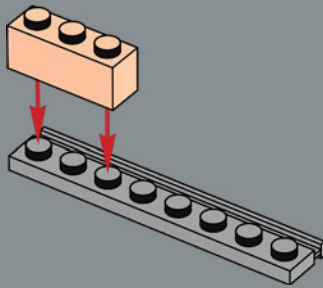

201

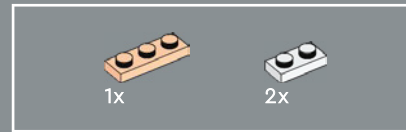
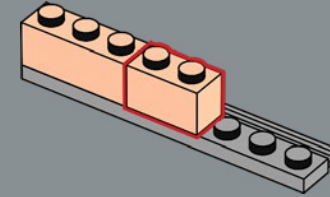

202

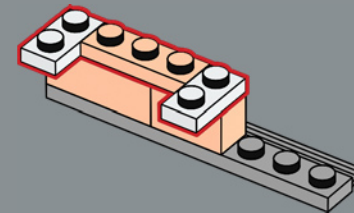

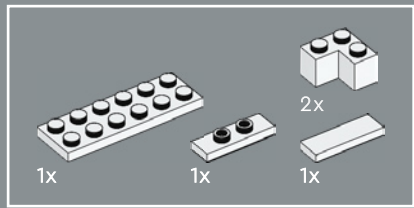

203

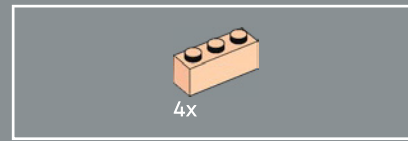
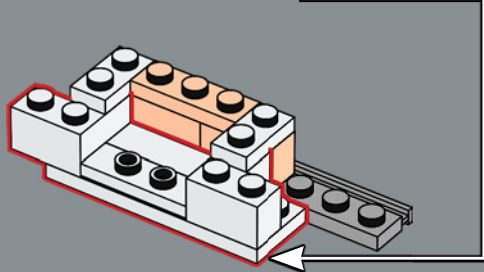
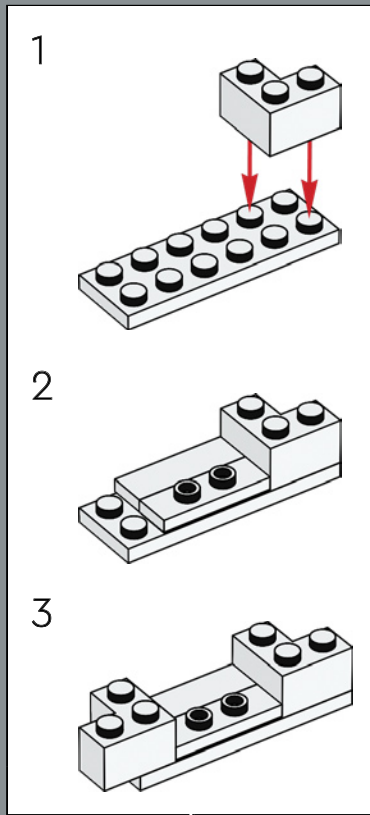

204

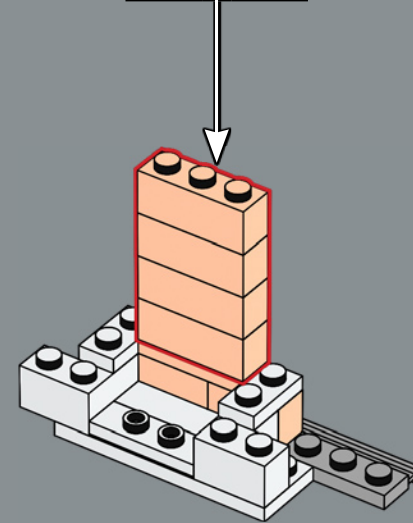
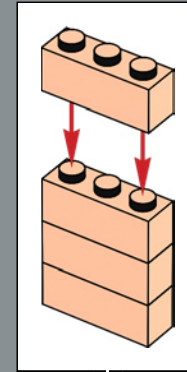



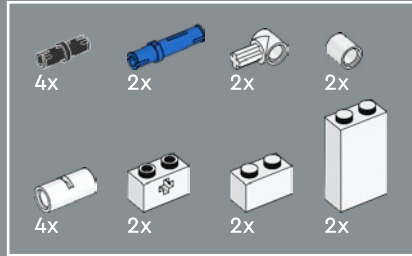
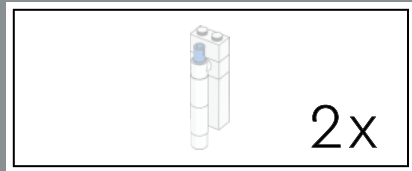

209

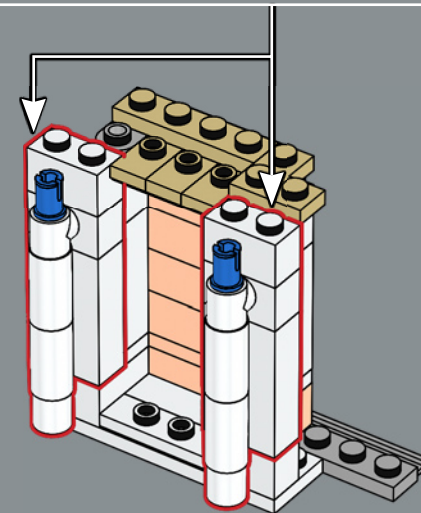
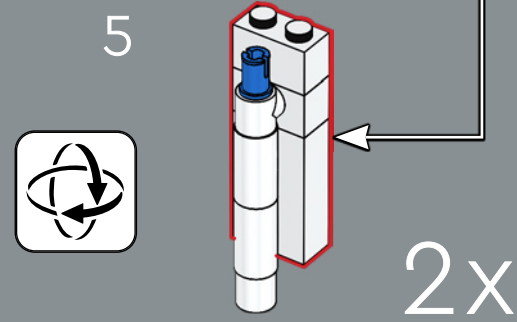
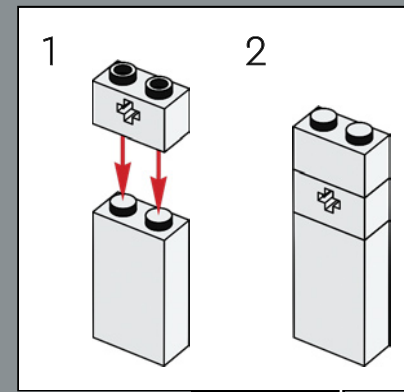
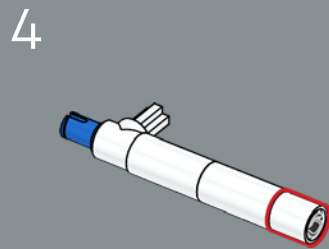
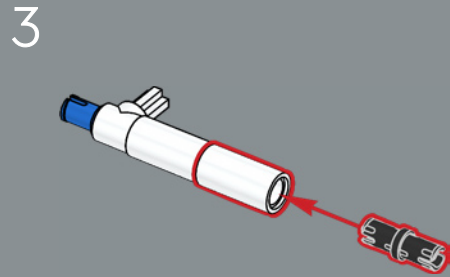
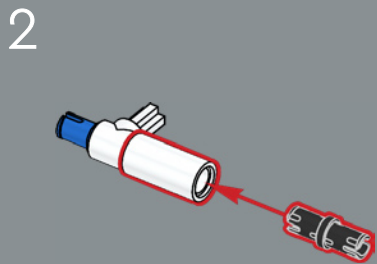
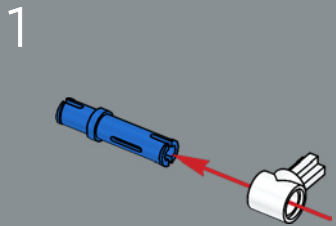



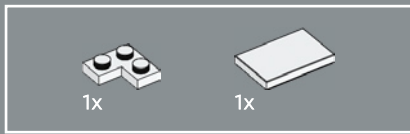

210

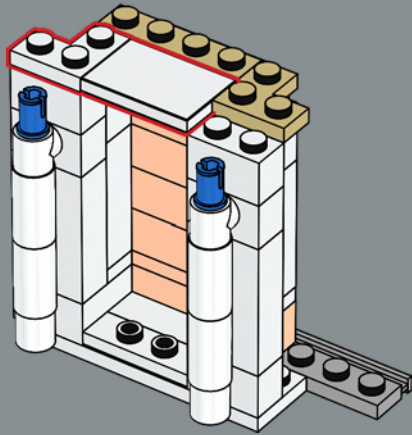

211

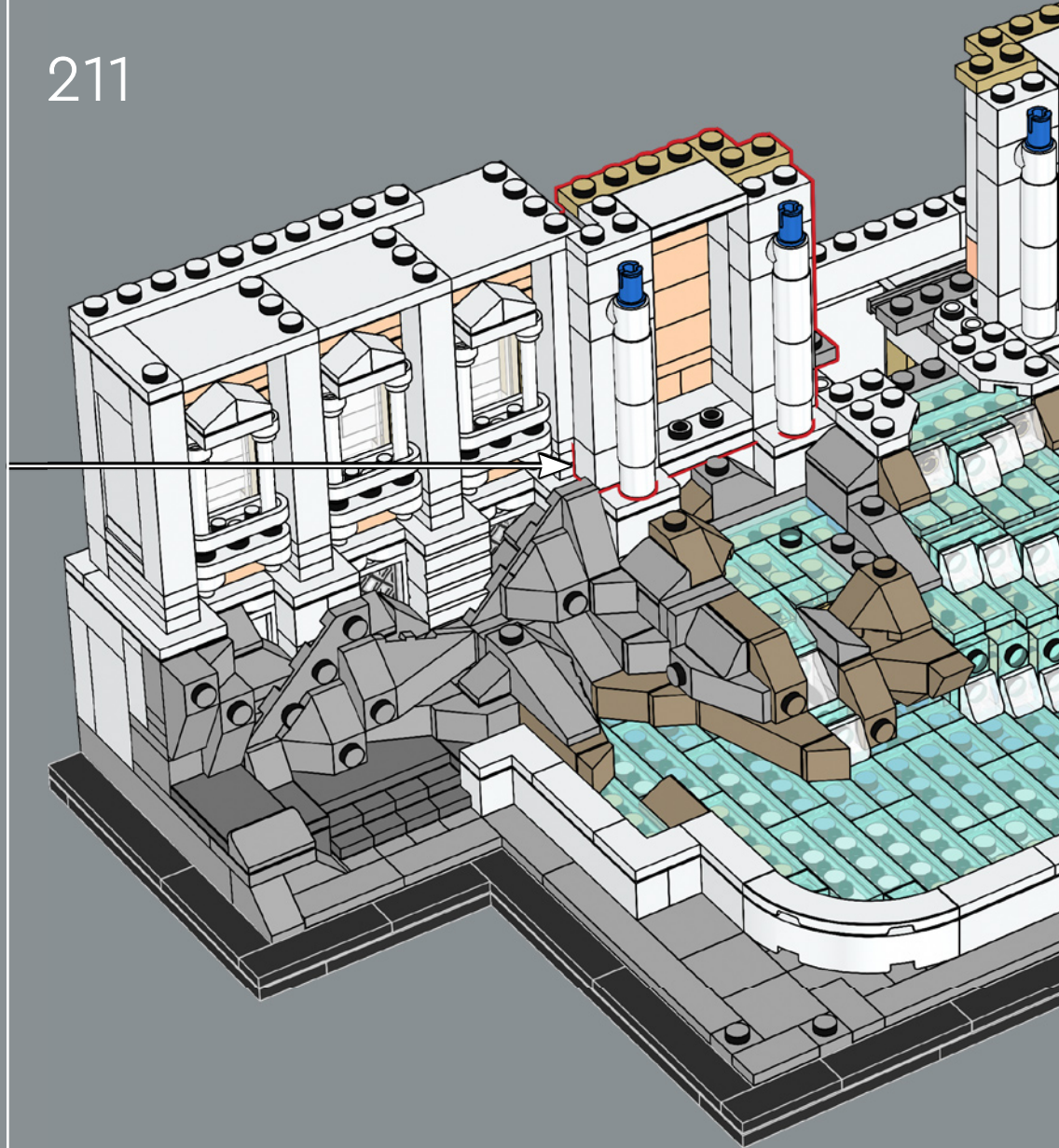

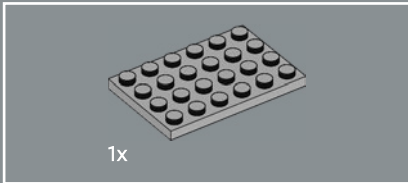
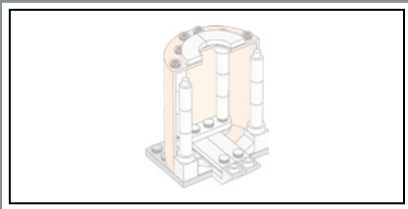

1x

212

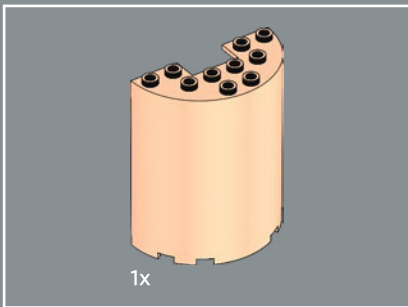
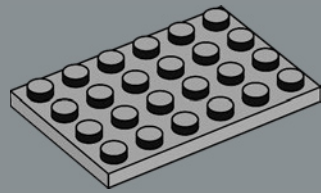

1x

213

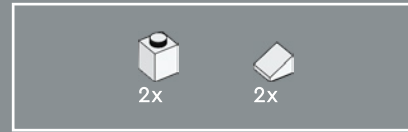
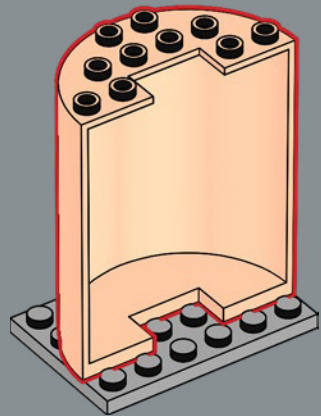

2x

2x

214

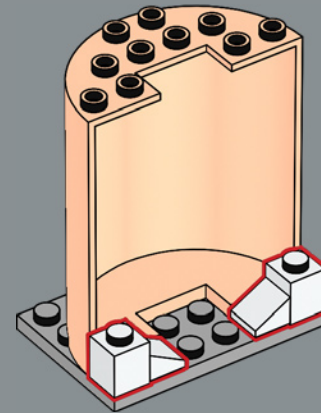

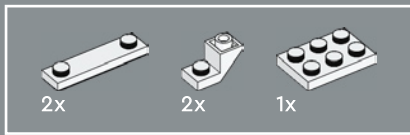

215

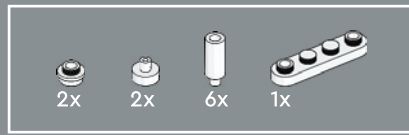
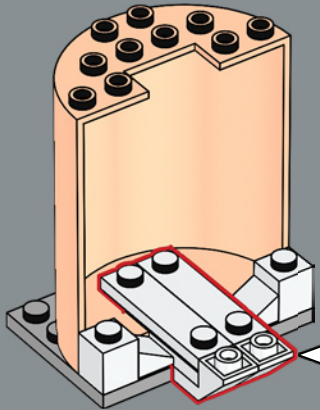
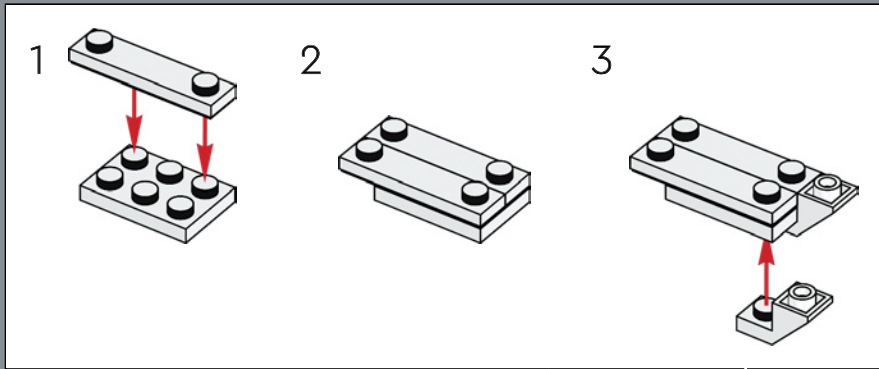

216

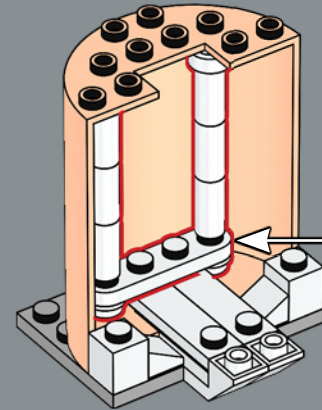
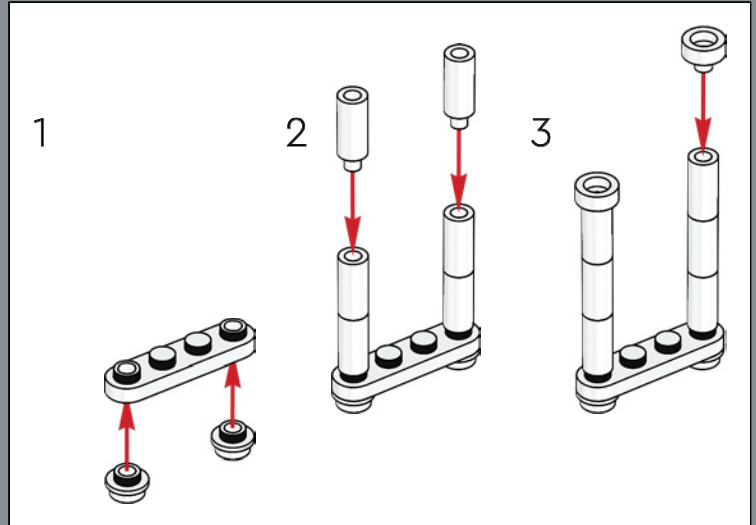



217

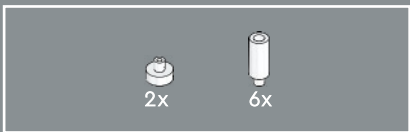
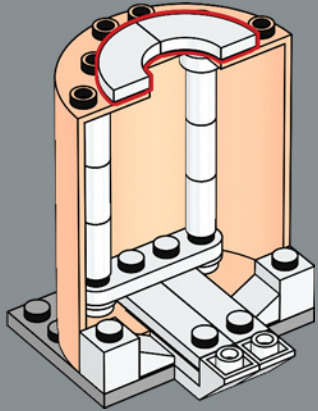

218

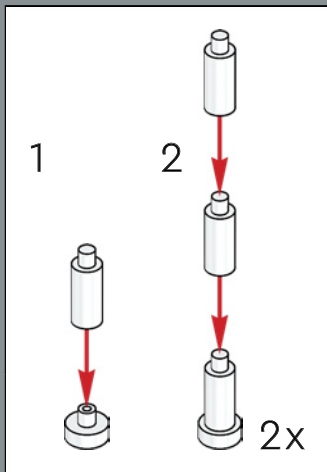
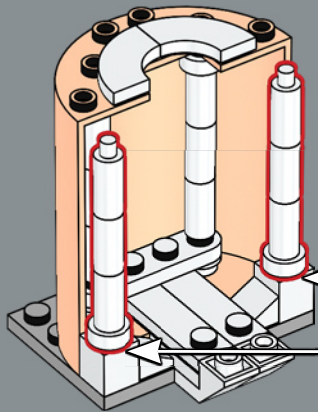

219

Toda la fachada está dividida en nueve secciones verticales, una disposición que permite destacar un punto focal en el centro. Replicar esto con ladrillos LEGO® requería el uso de un número impar de módulos y placas con espiga central para posicionar el arco principal en el eje.

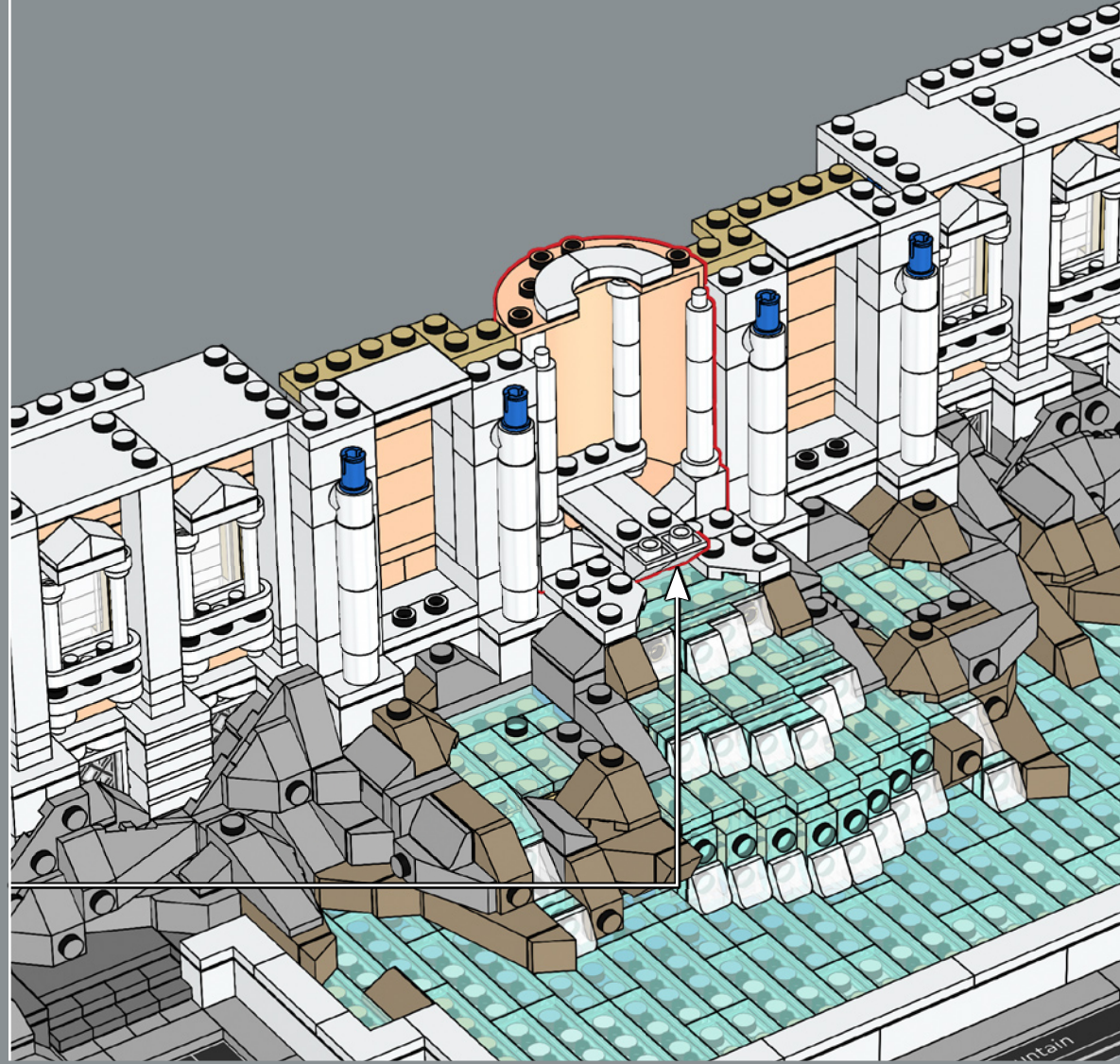

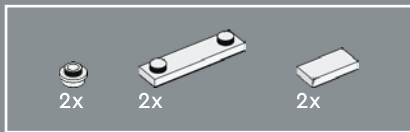

220

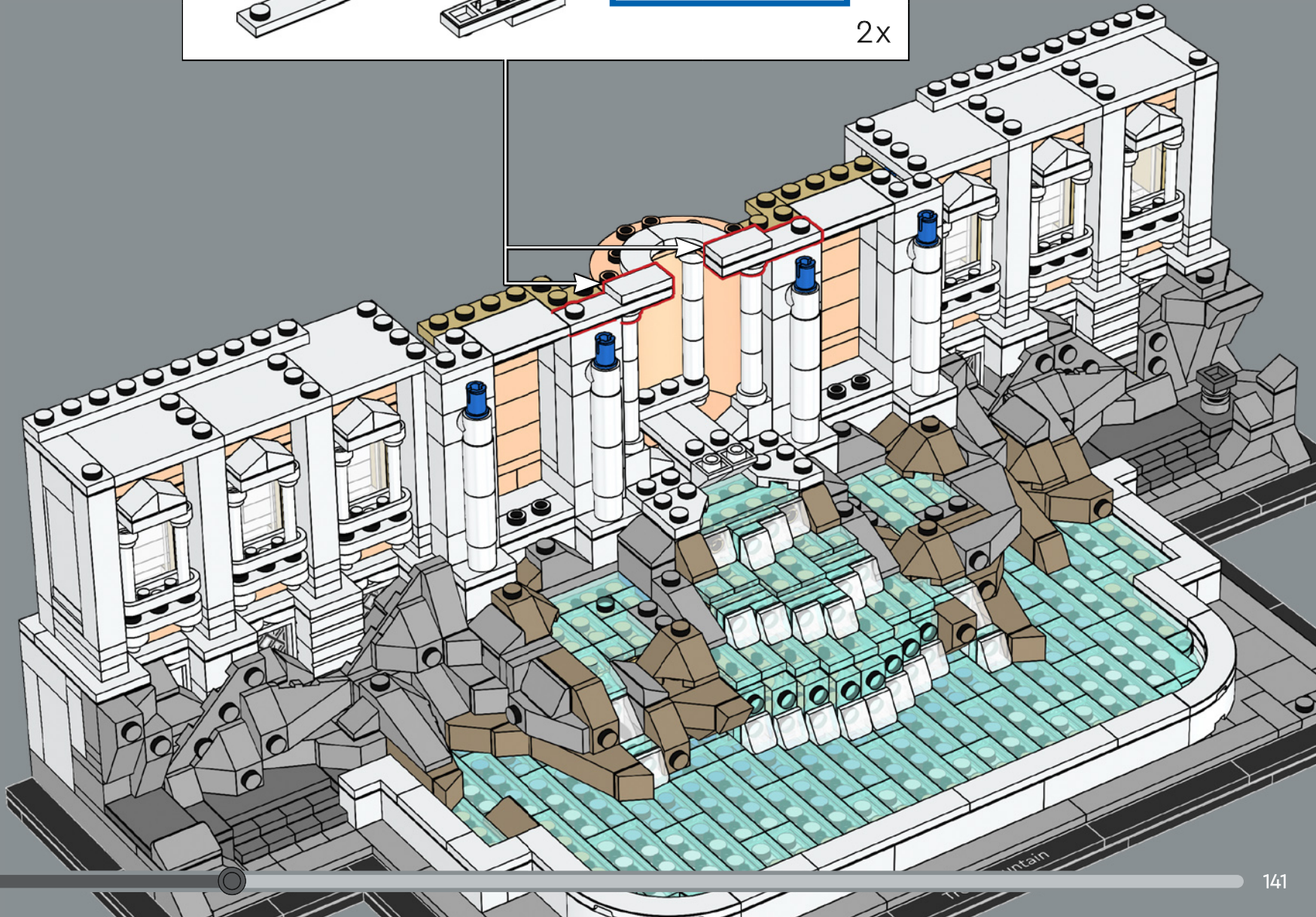
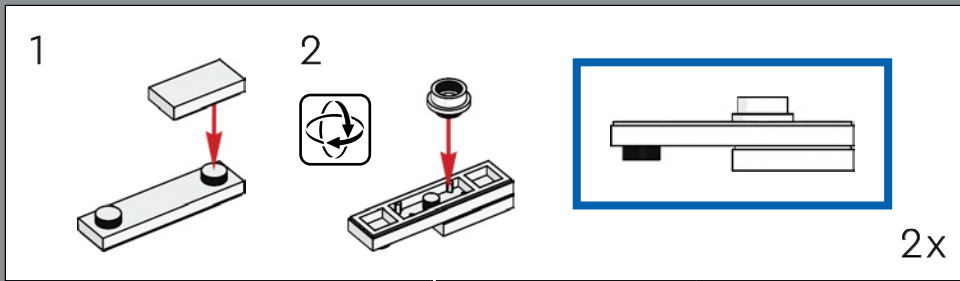

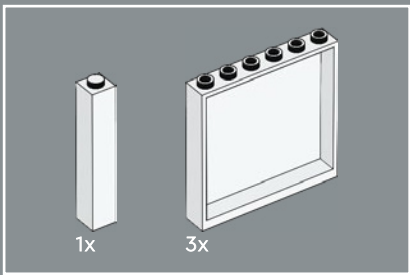

221

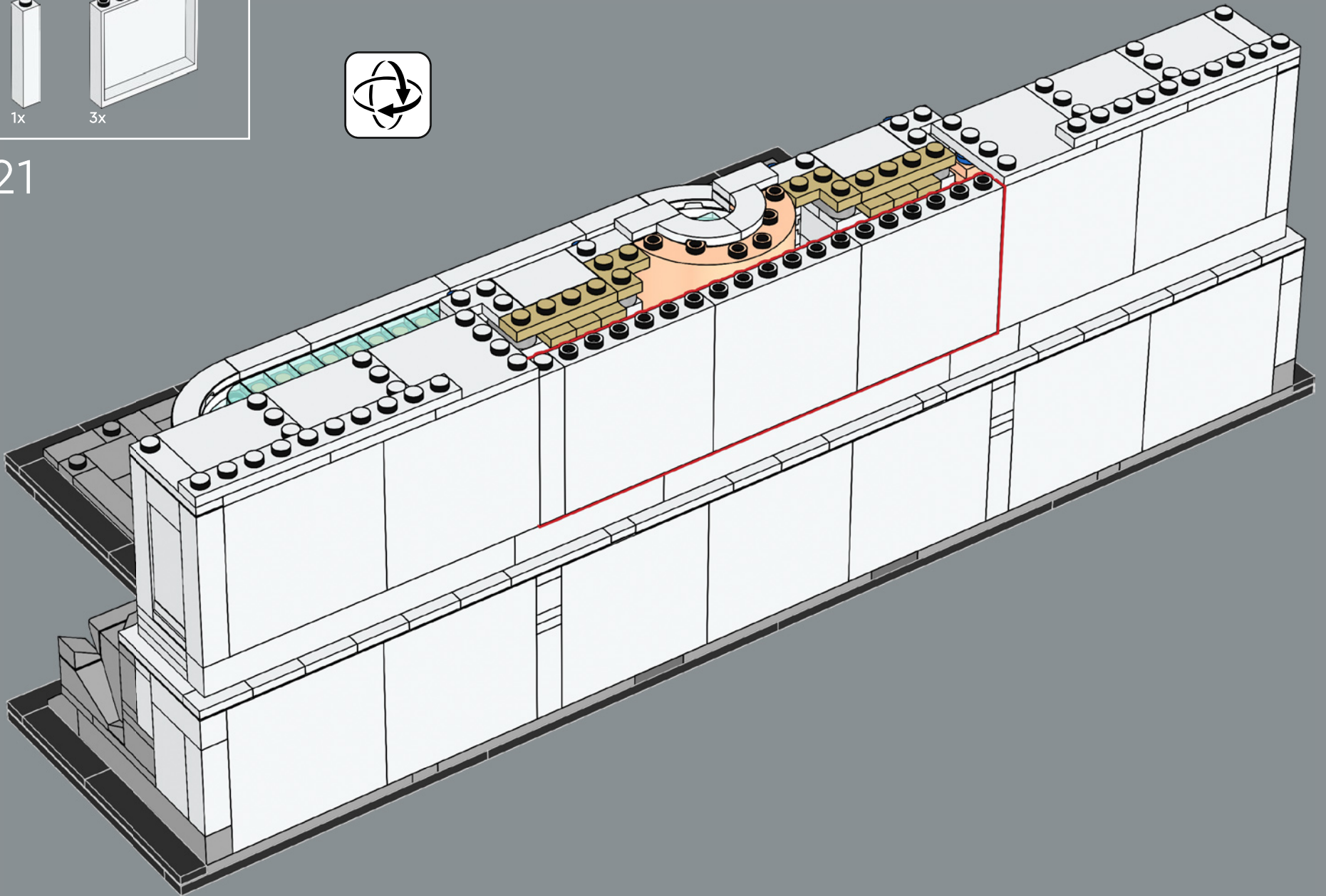

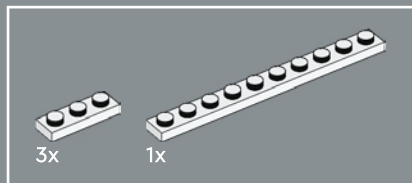

222

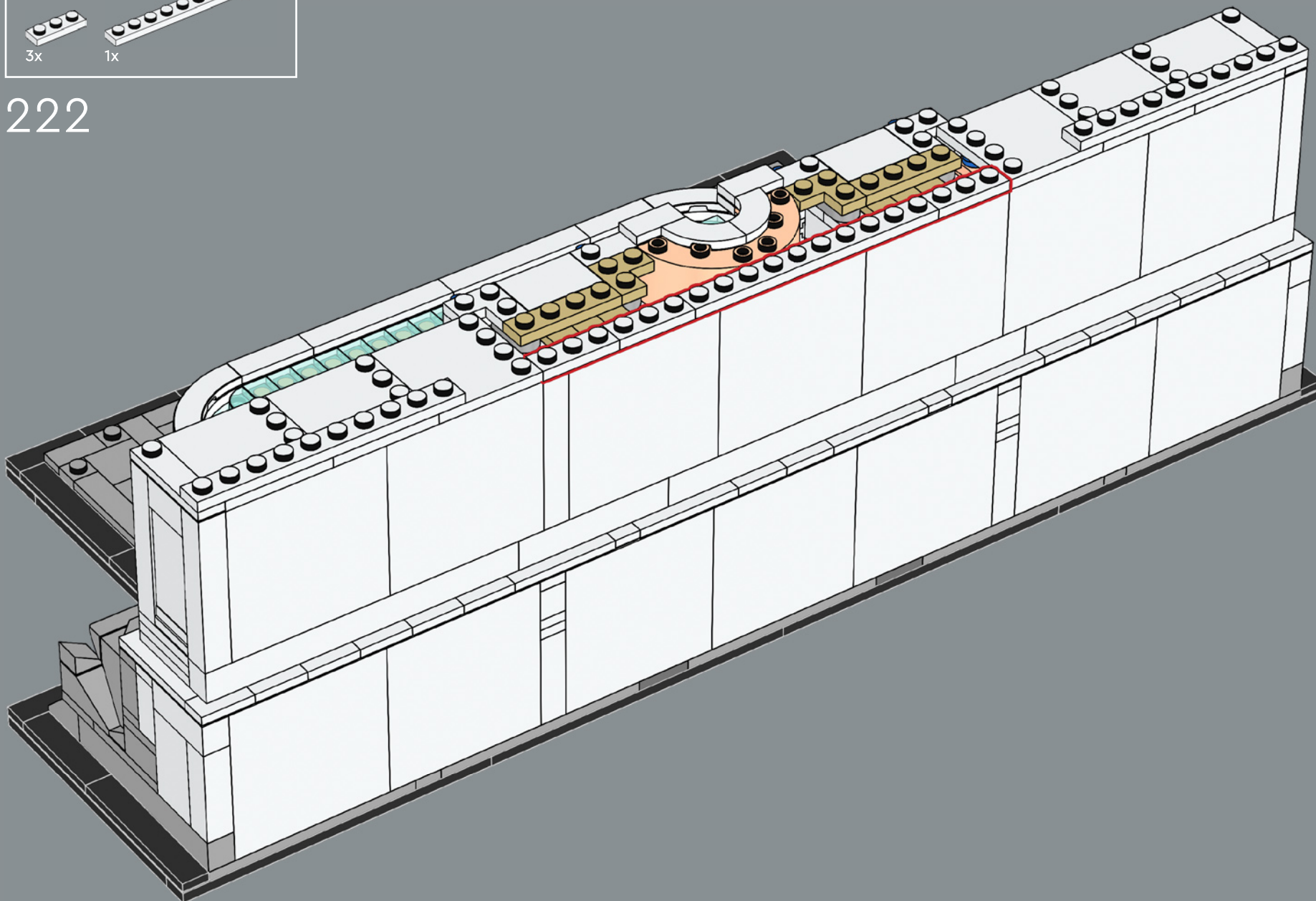

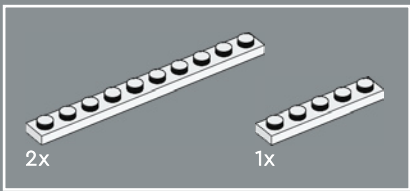

223

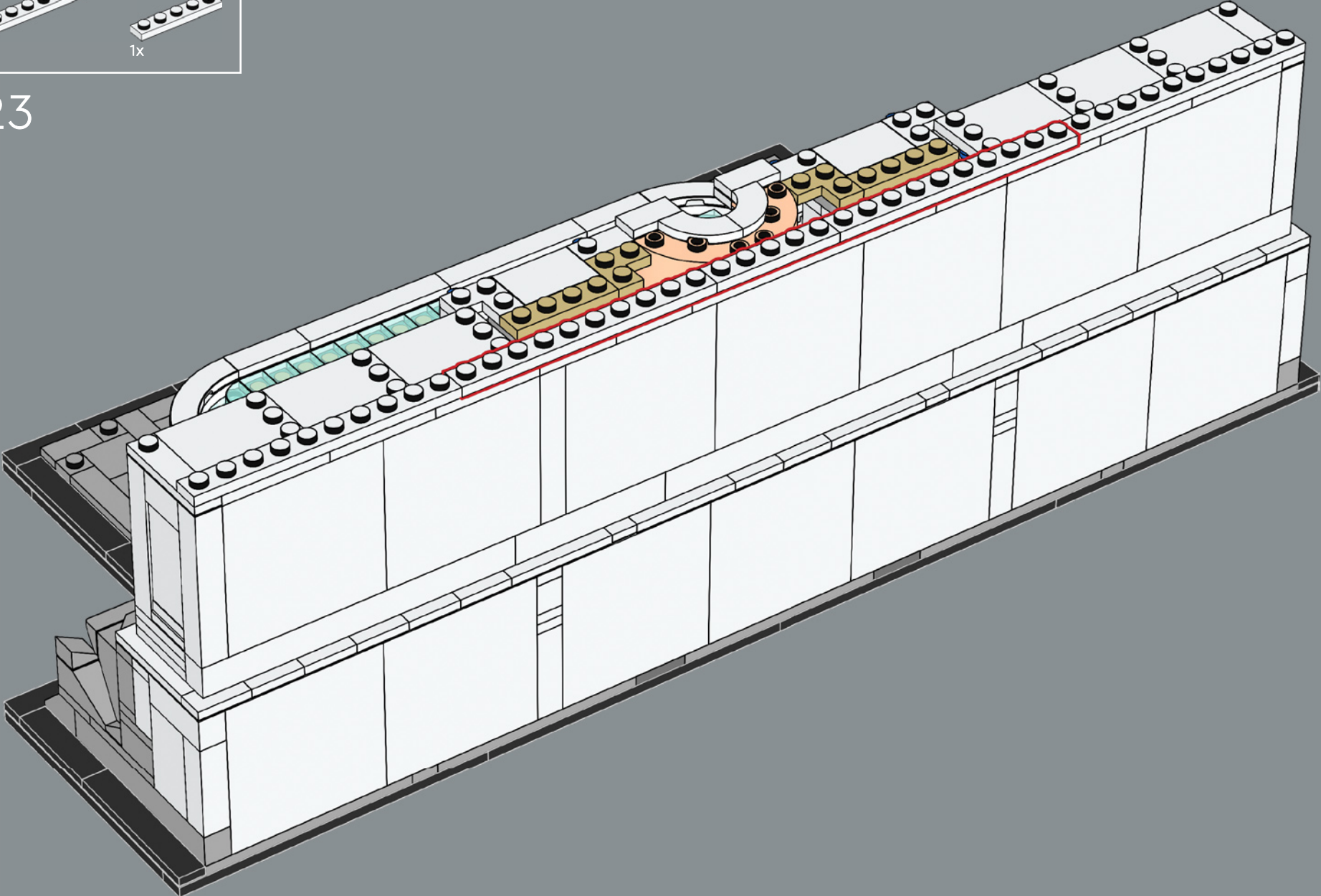



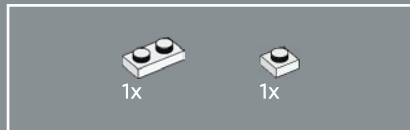
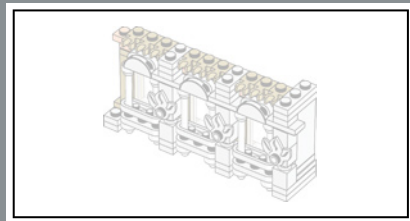

224

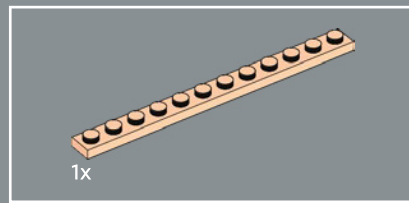
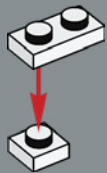

225

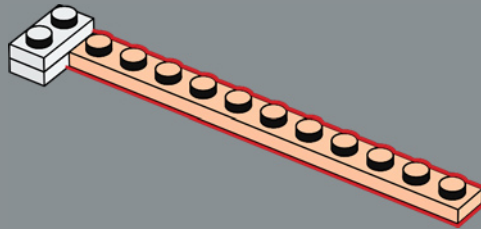

226

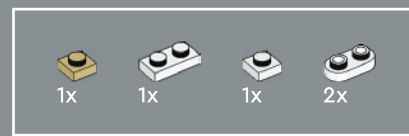
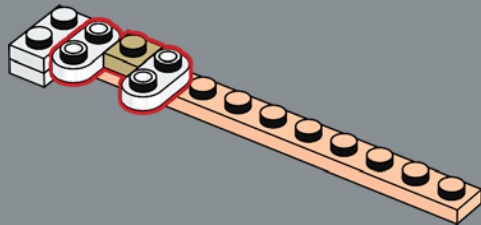

227

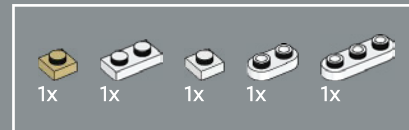
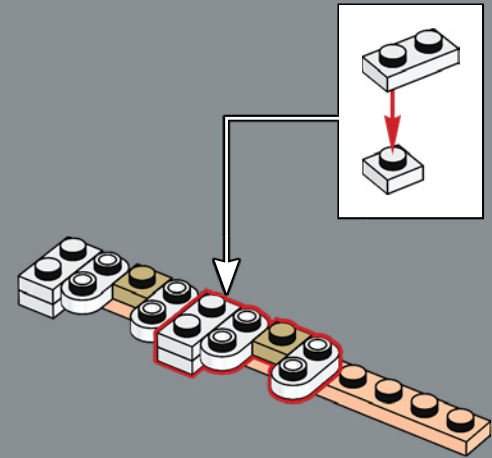

228

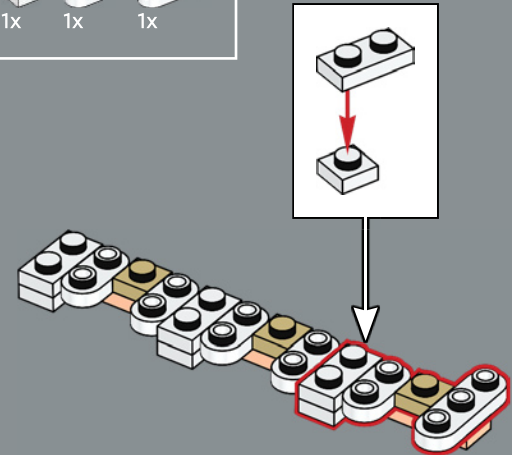

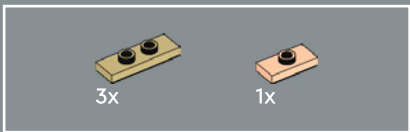

229

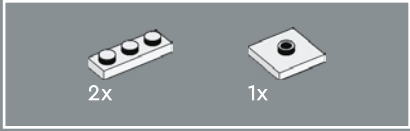
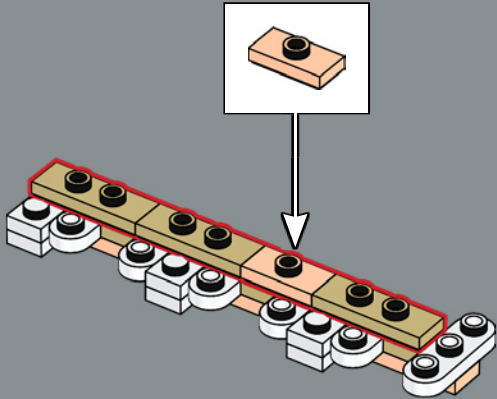

230

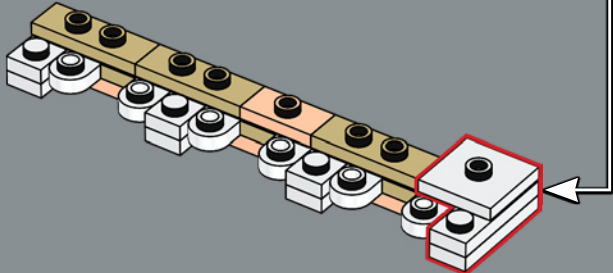
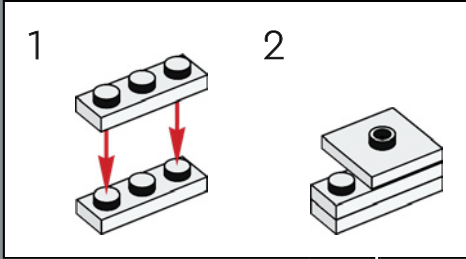

231

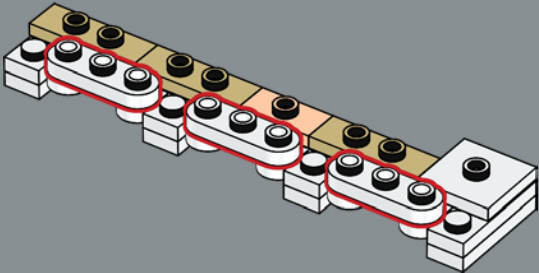

232

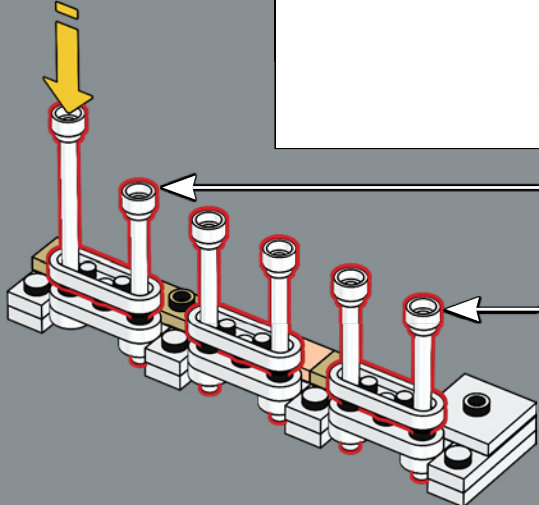
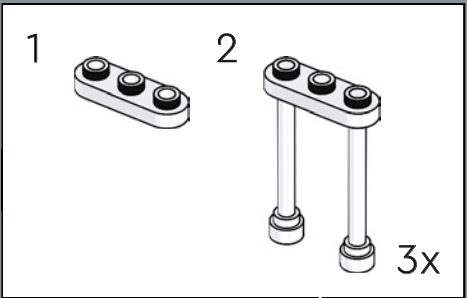

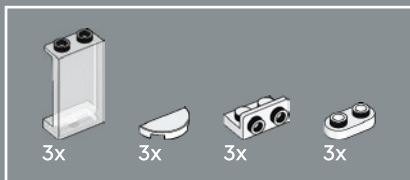

233

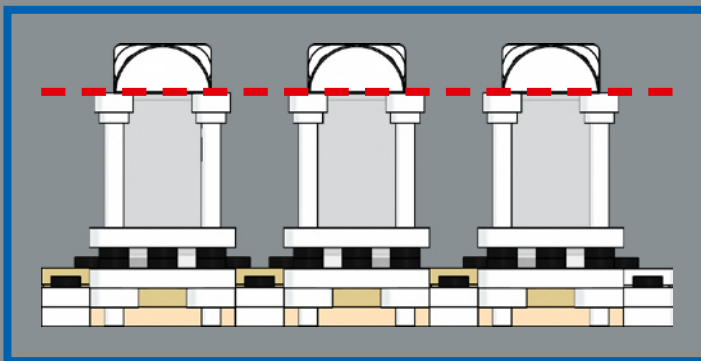

La ventana situada más a la derecha es, en realidad, falsa; está pintada de manera que imita la apariencia de las otras 11 ventanas.

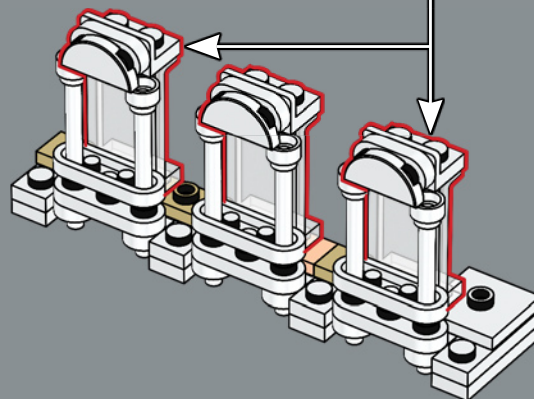
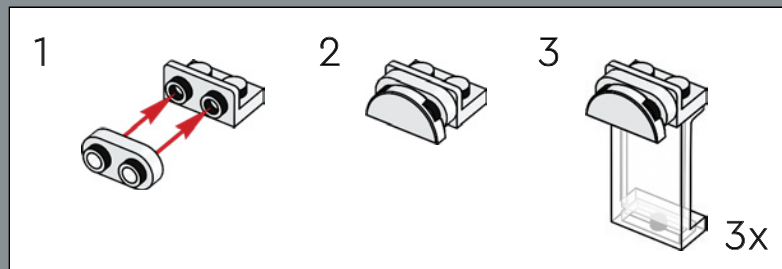

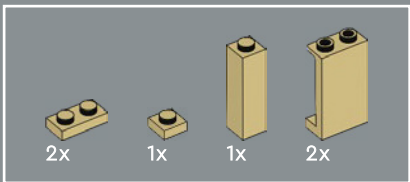

234

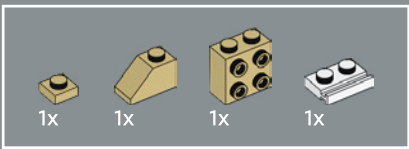
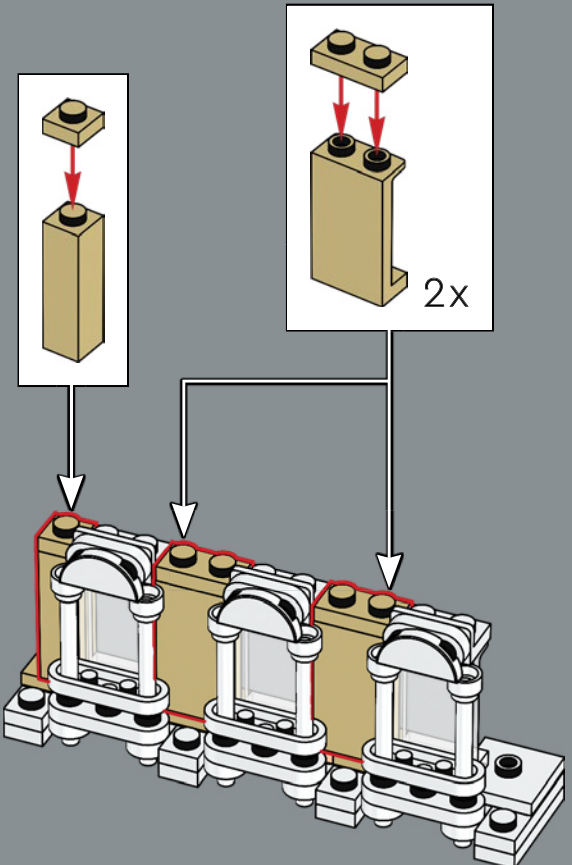

235

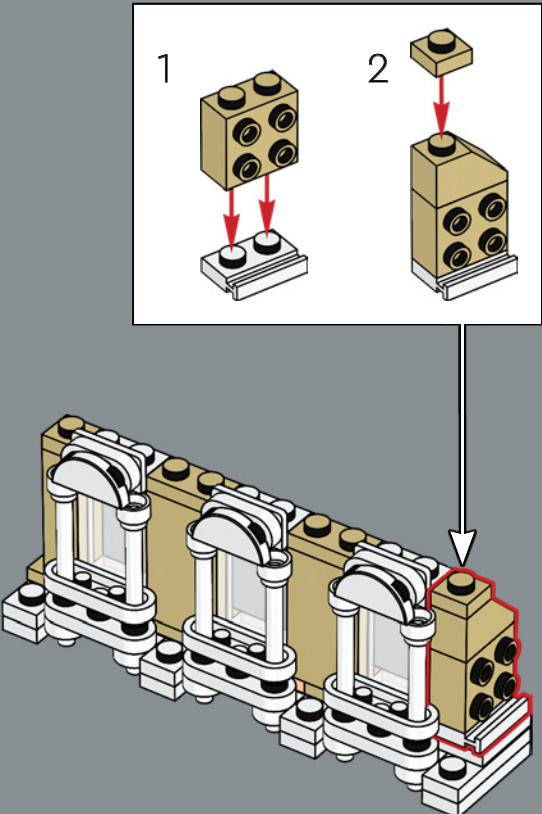

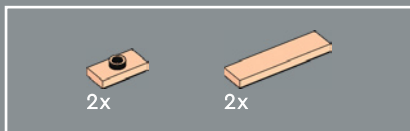

236

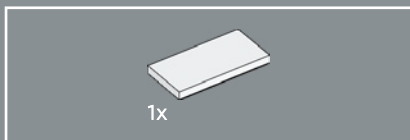
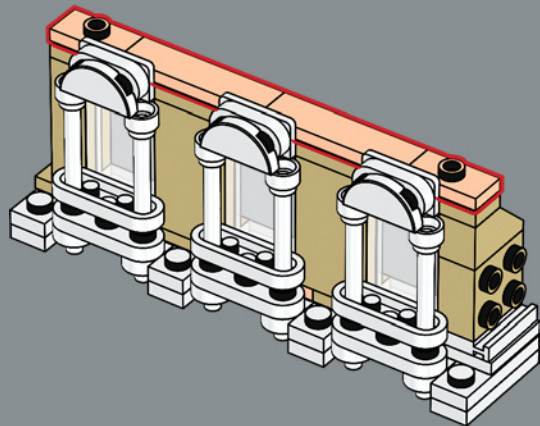

237

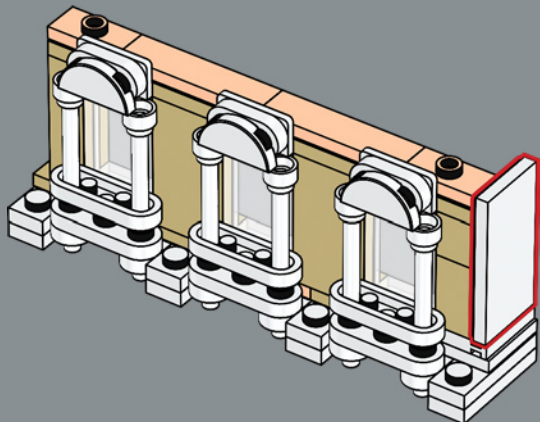

238

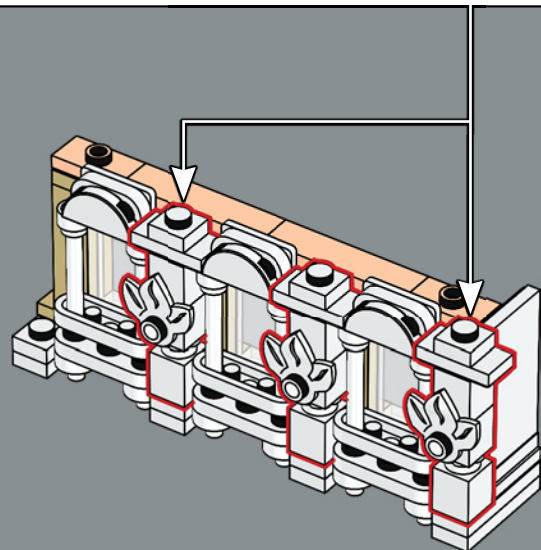
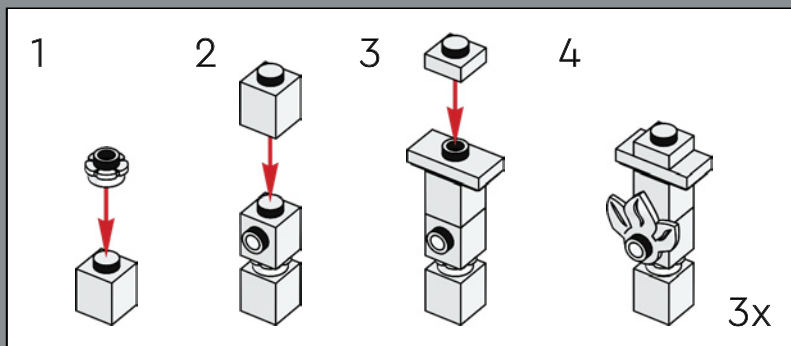

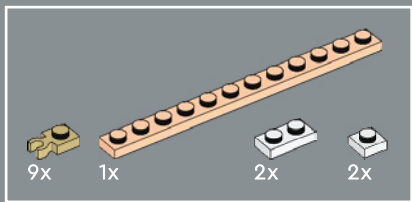

239

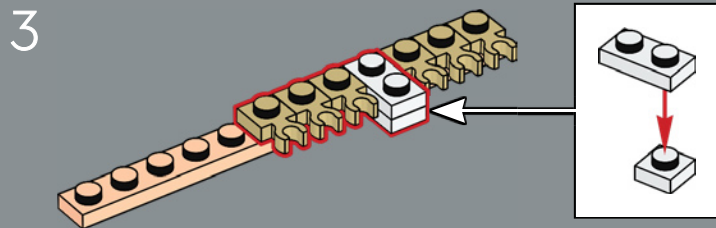
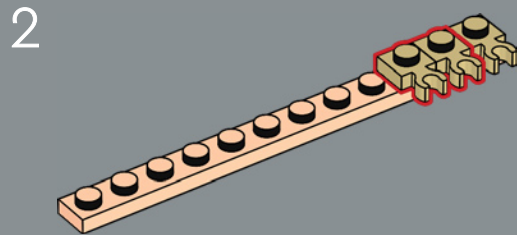
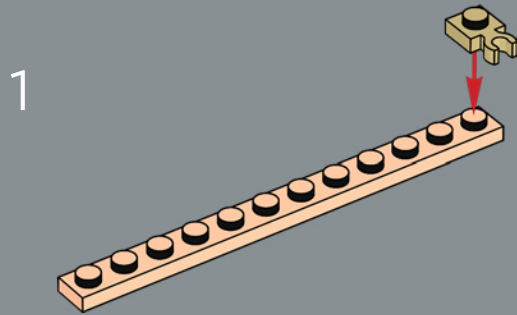

4

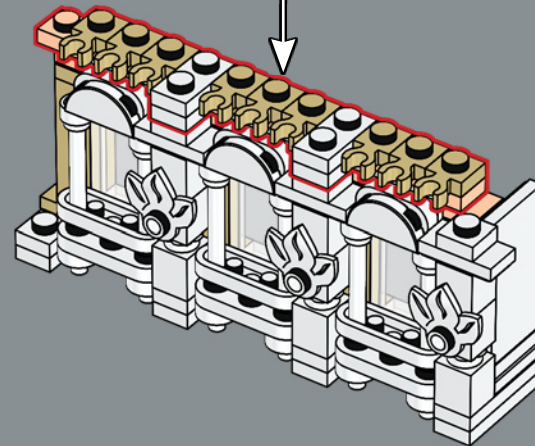
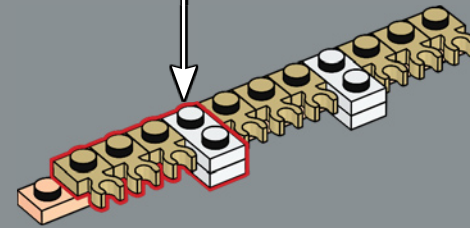
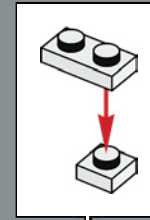

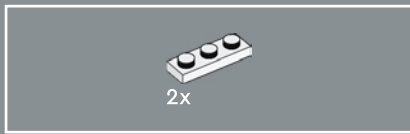

240

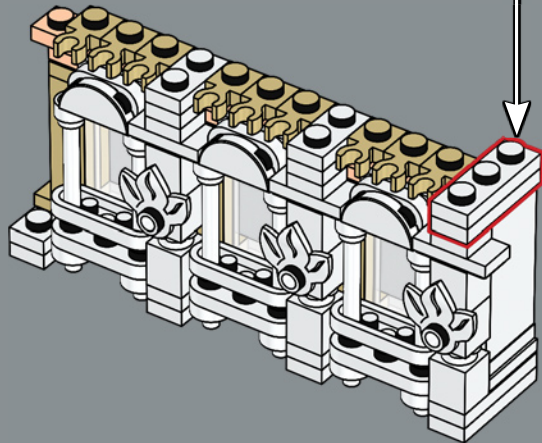
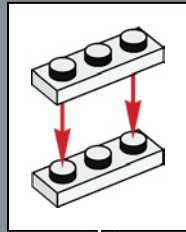

241

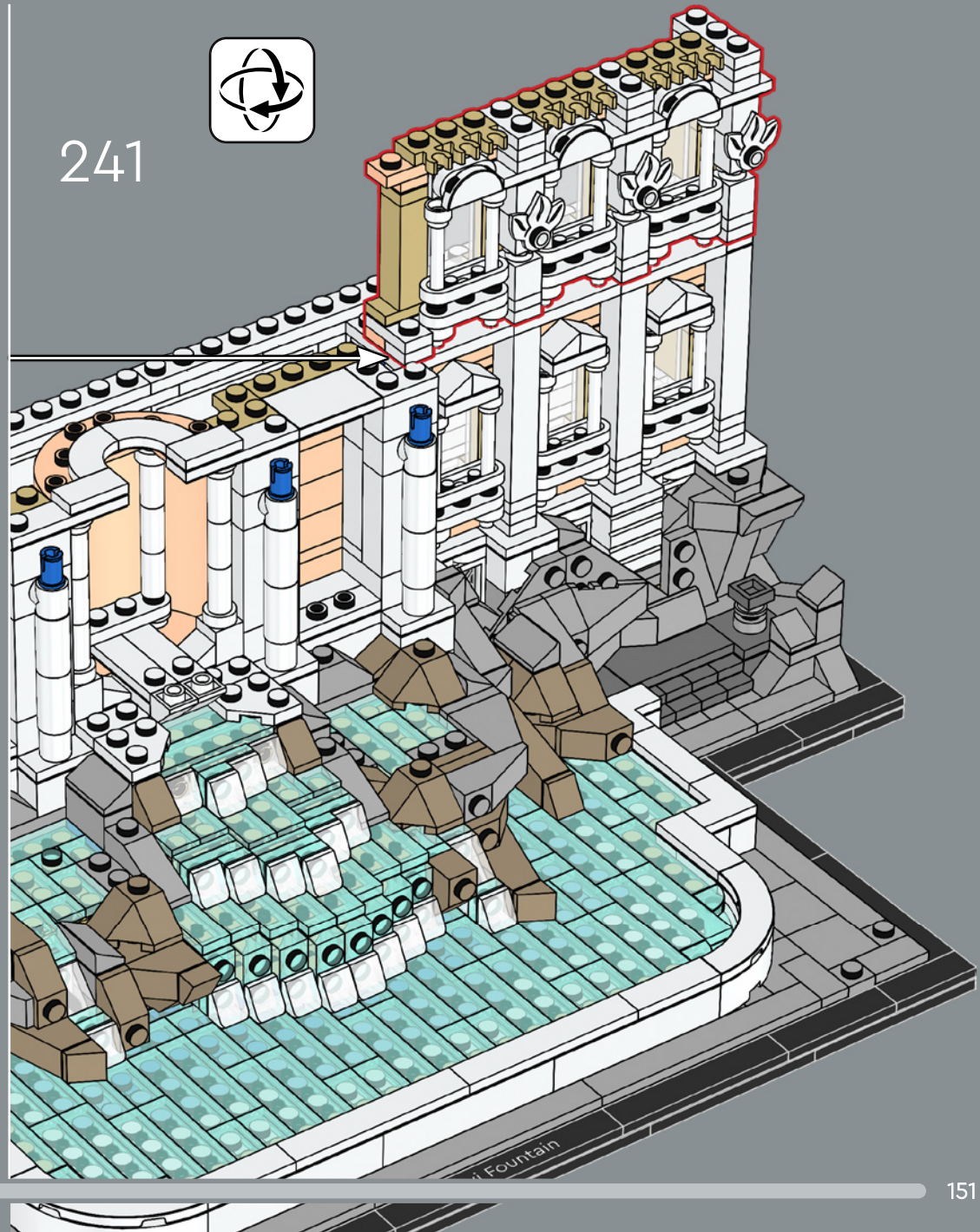

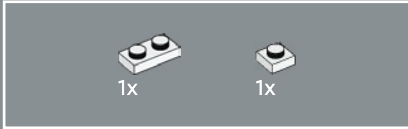
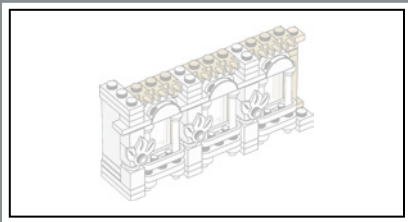

242

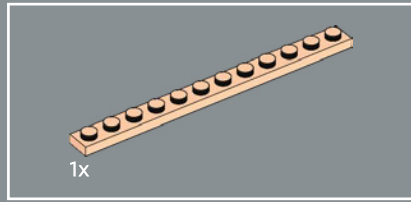
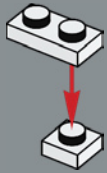

243

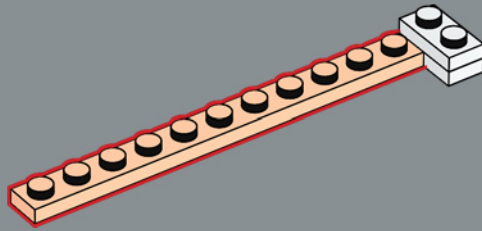

244

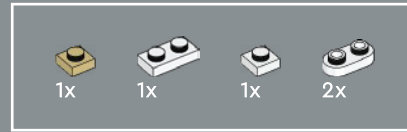
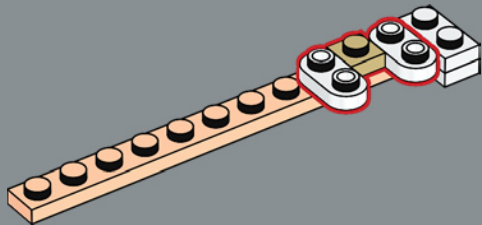

245

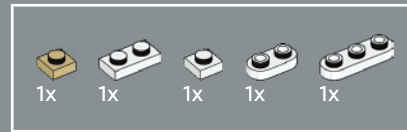
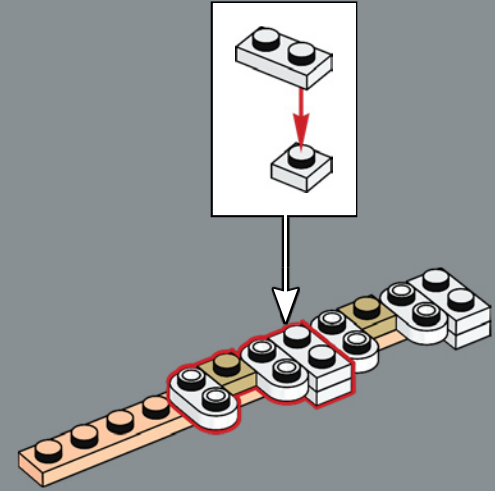

246

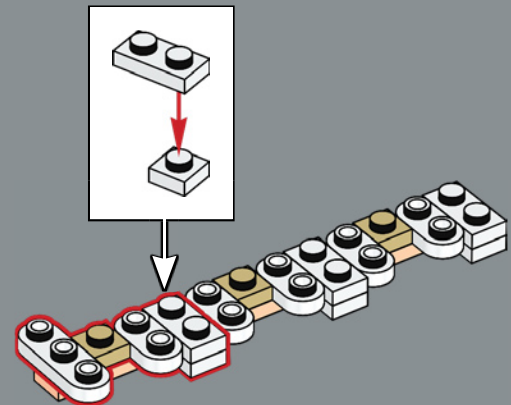



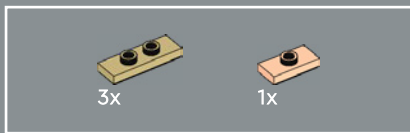

247

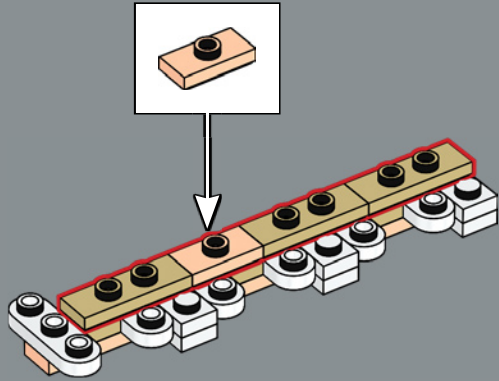

248

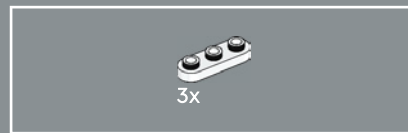
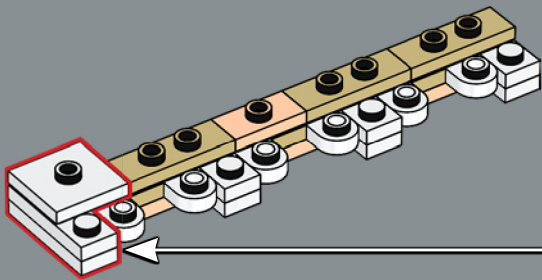
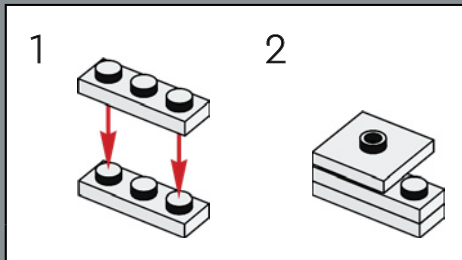

249

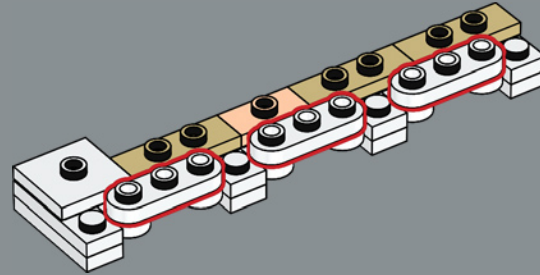

250

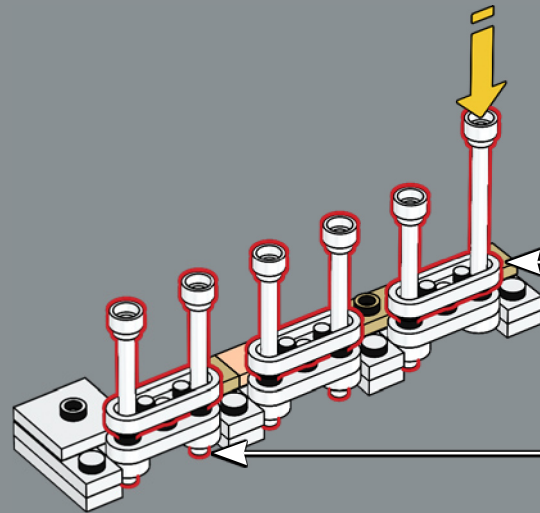
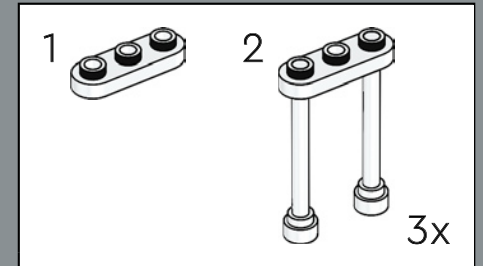

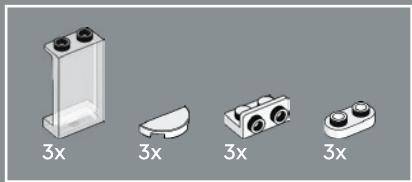

251

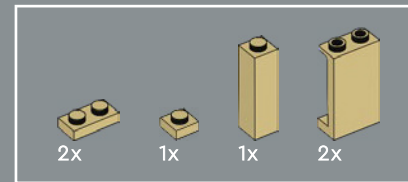
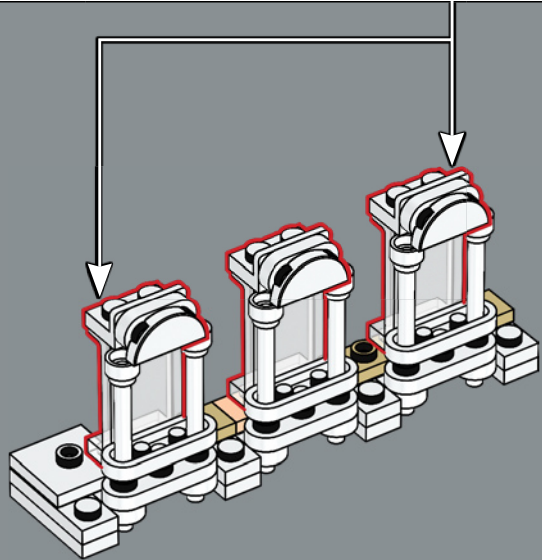
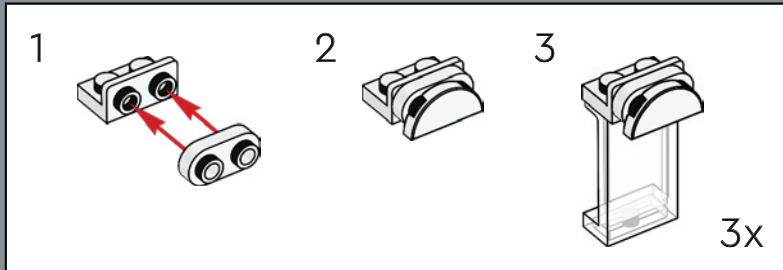
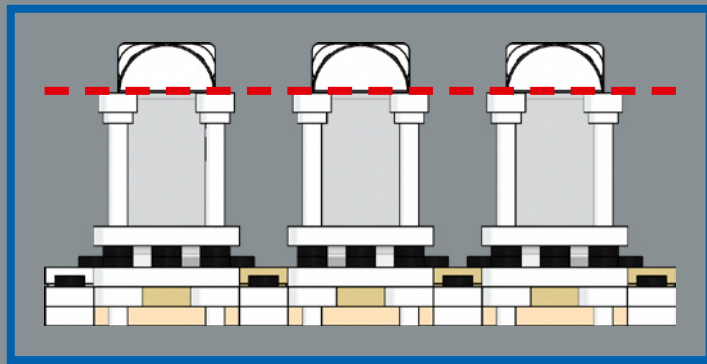

252

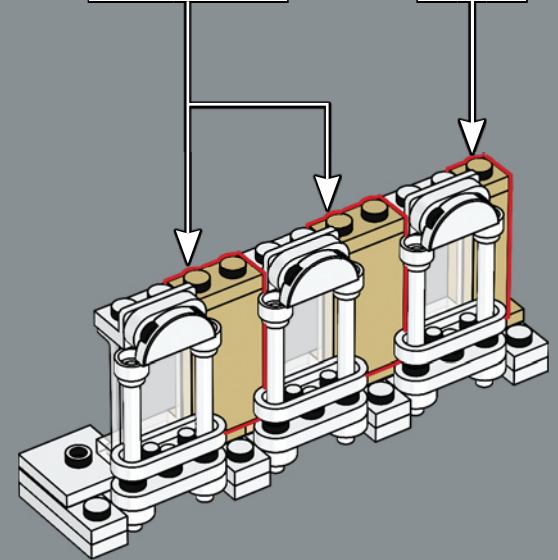
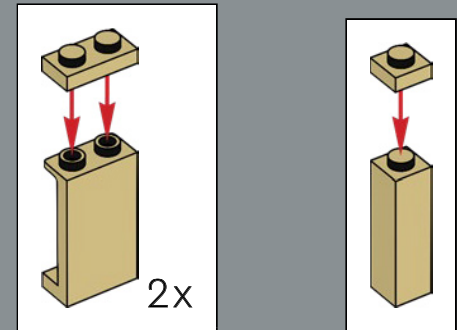

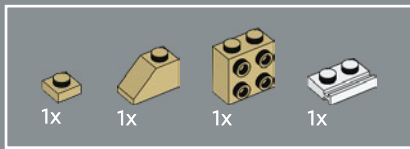

253

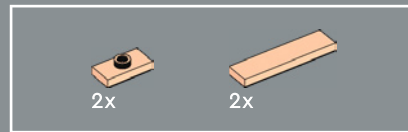
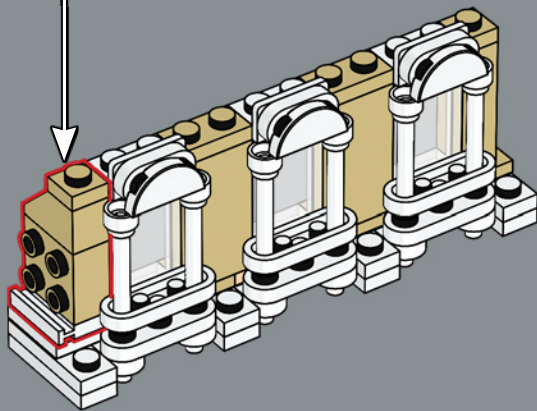
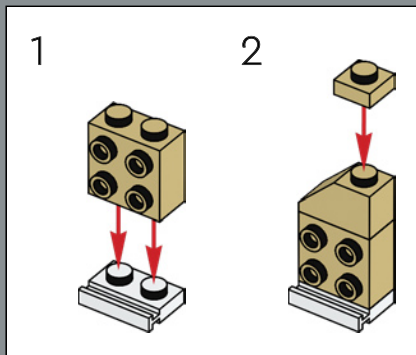

254

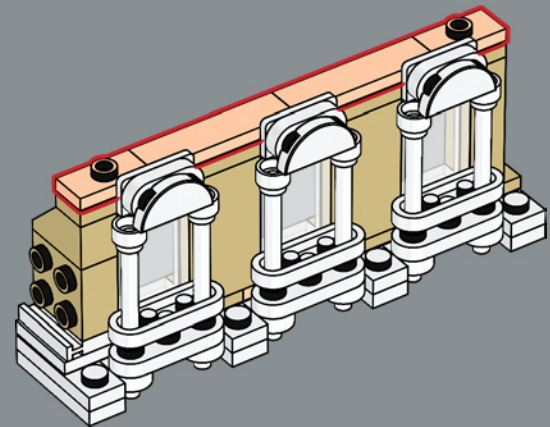

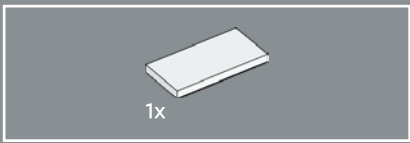

255

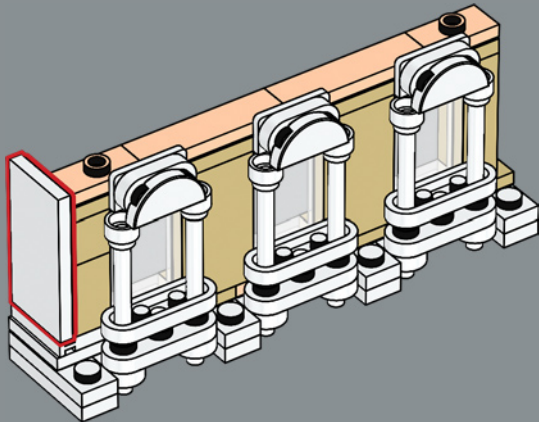

256

Los elementos LEGO® que representan hojas de esta sección ayudan a crear los capiteles de las columnas corintias.

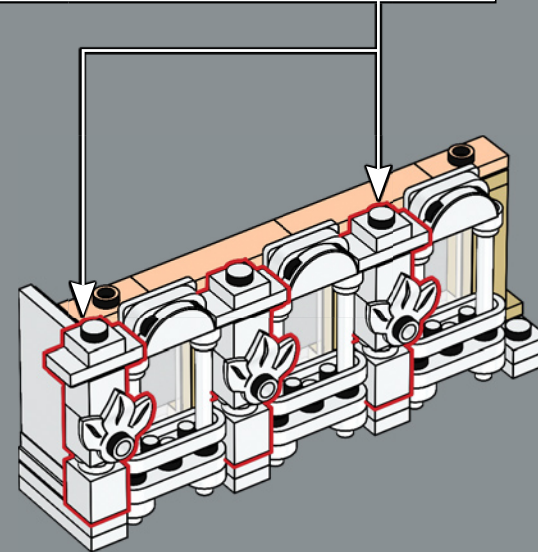
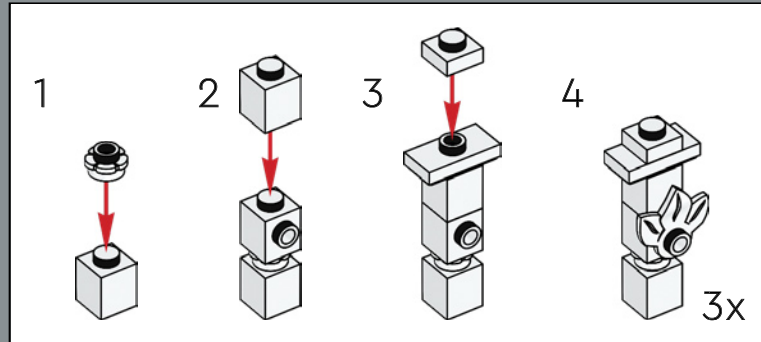

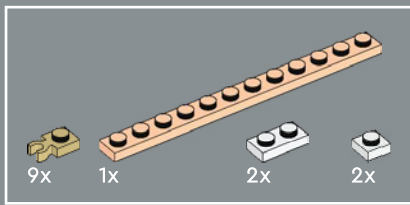

257

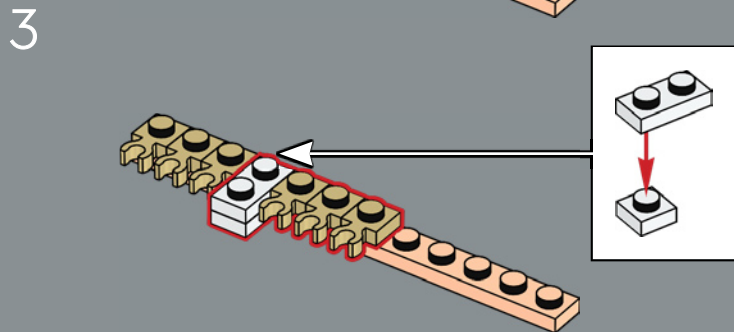
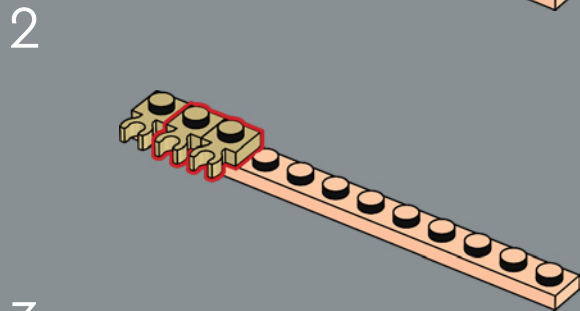
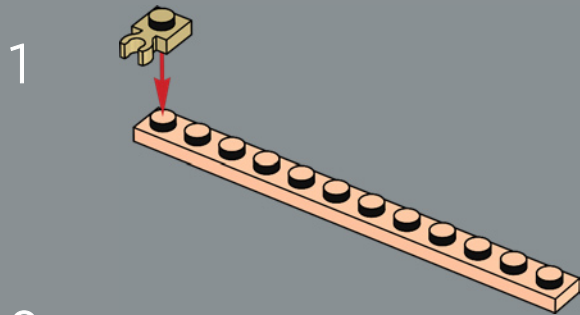

4

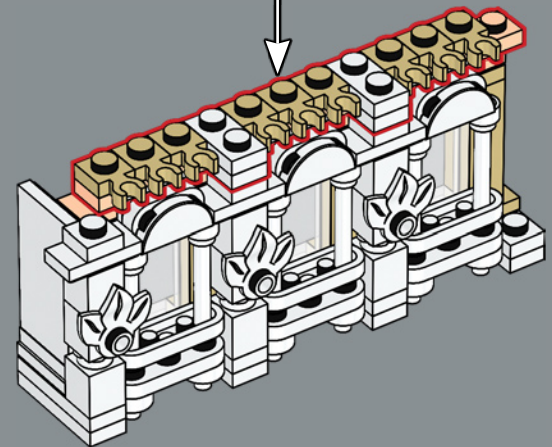
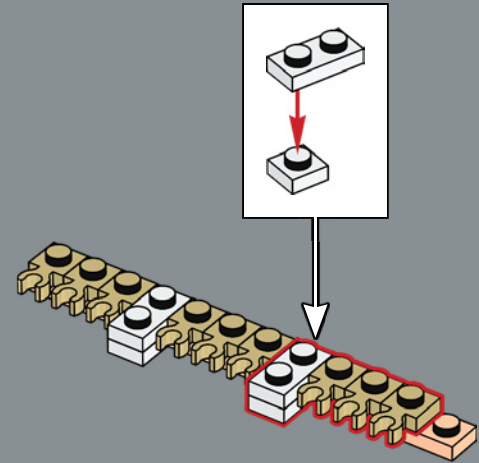



258

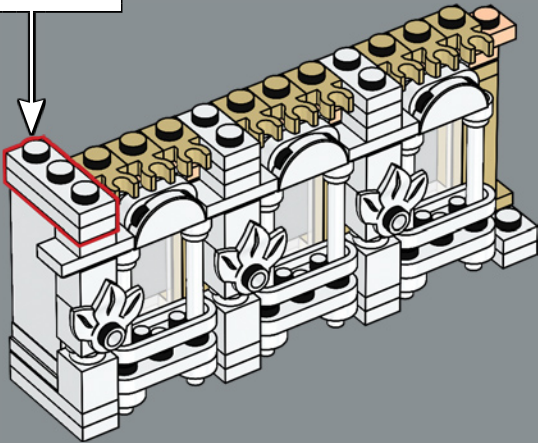
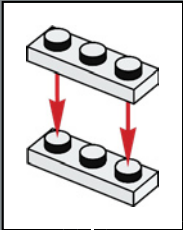

259

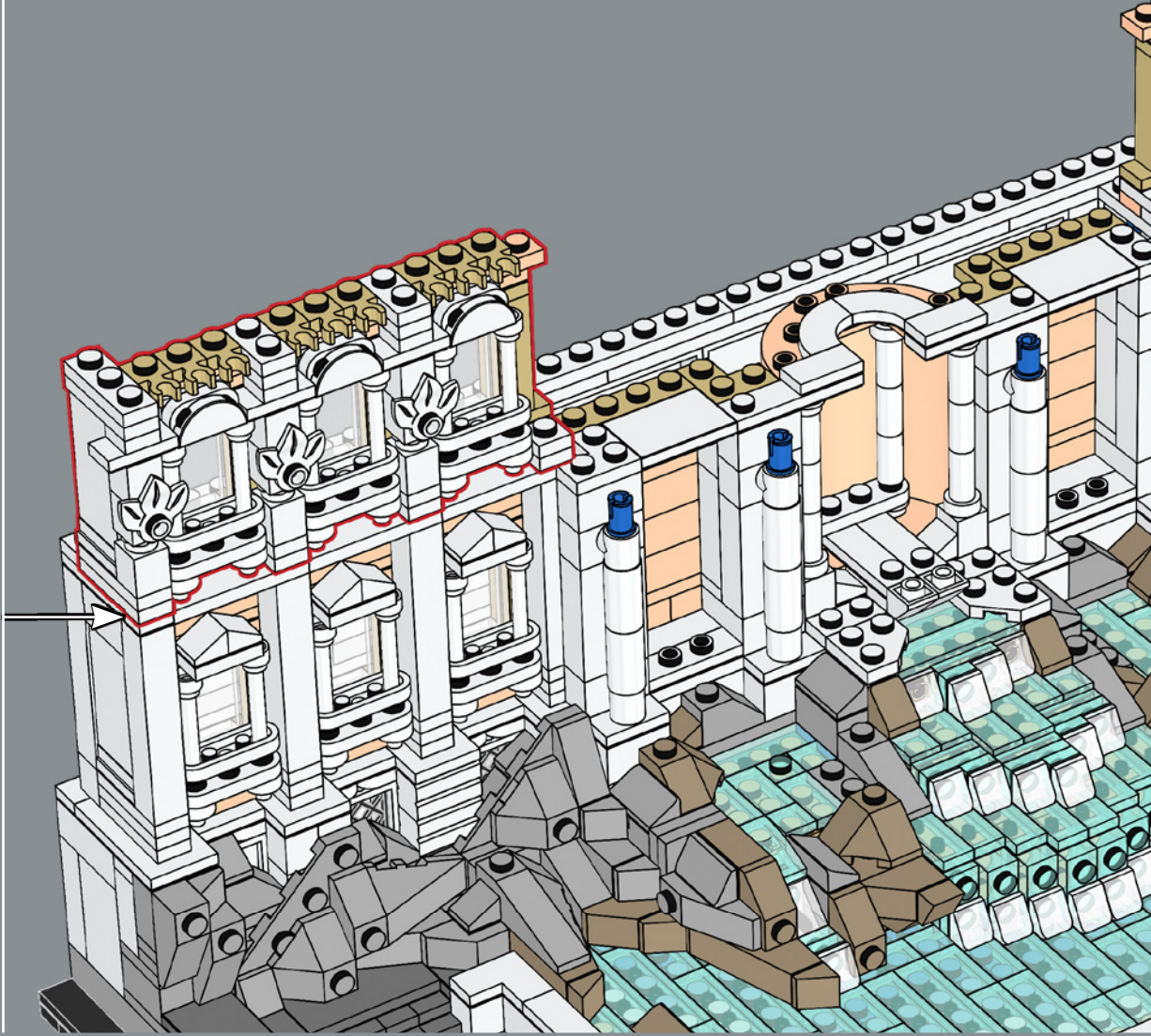

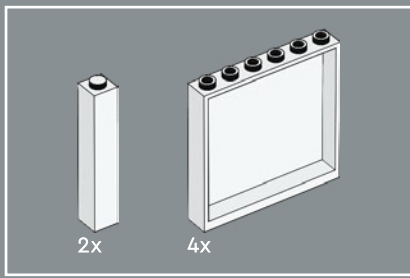

260

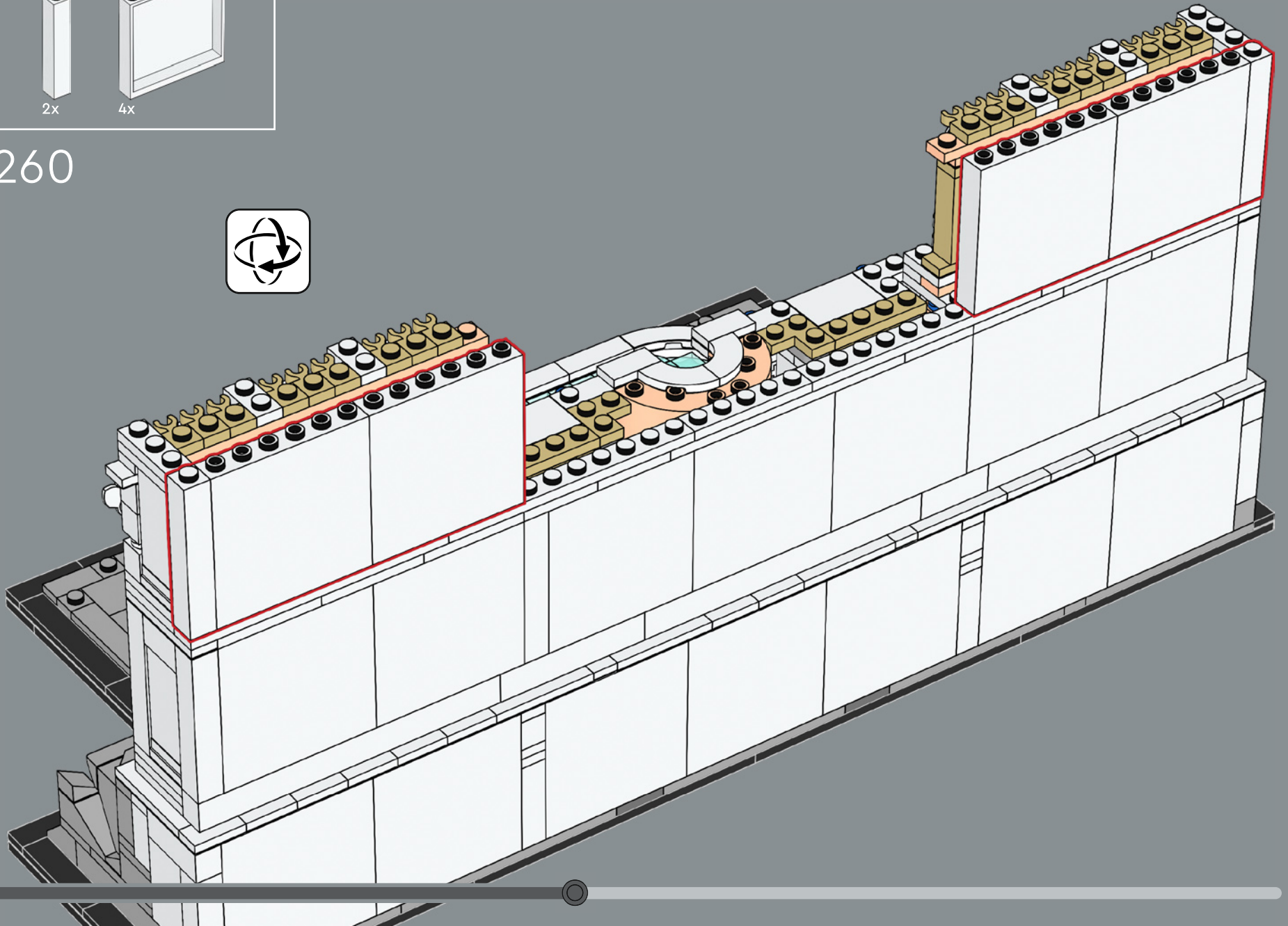



261

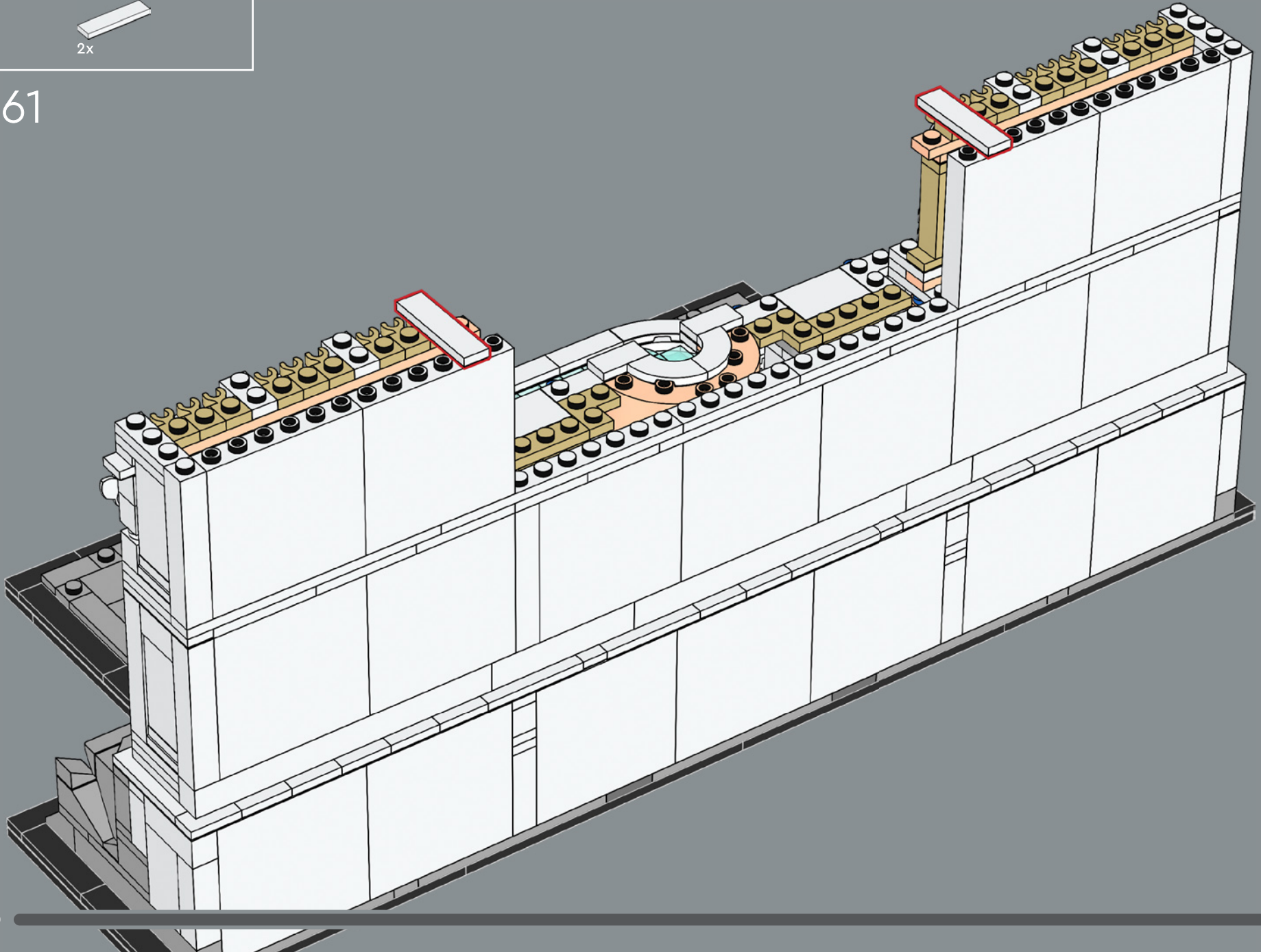



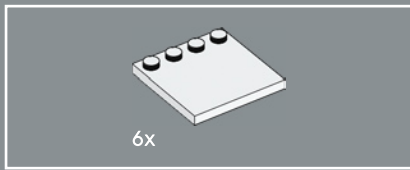

262

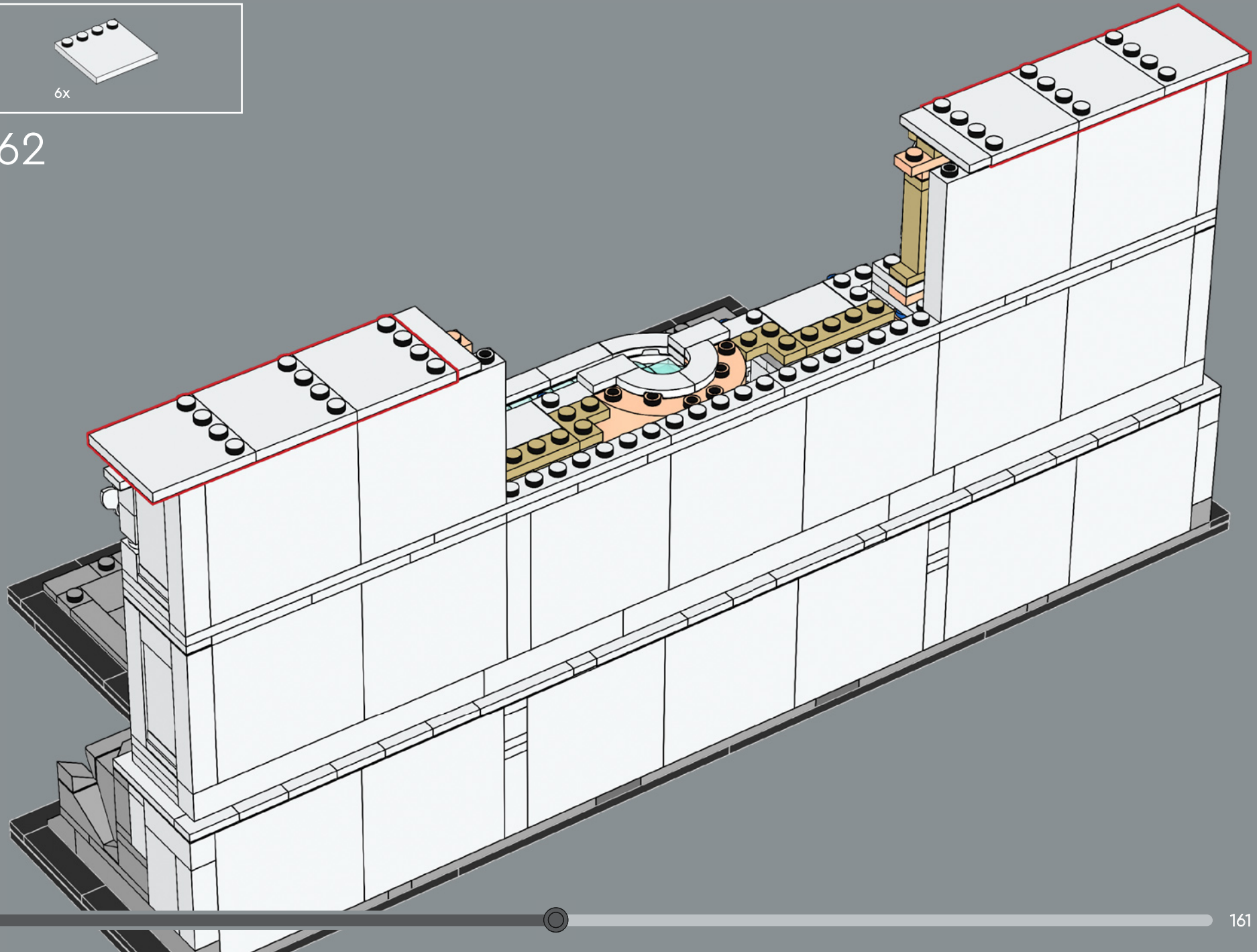

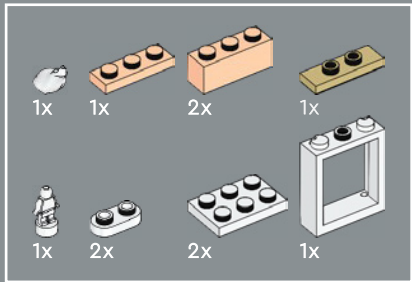

263

1

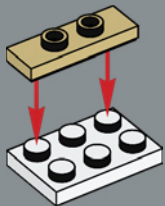

2

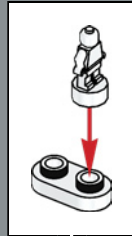
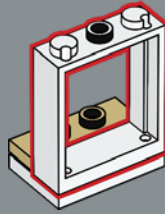

3

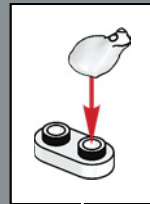
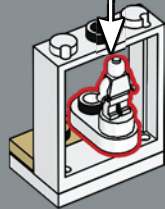

4



1

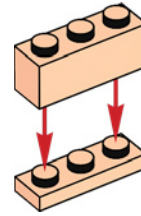

2

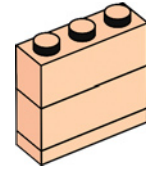

5



6



Los relieves de la izquierda y la derecha, una figura de pie y otra arrodillada, se representaron aquí con una rana y un trofeo para minifiguras LEGO®.

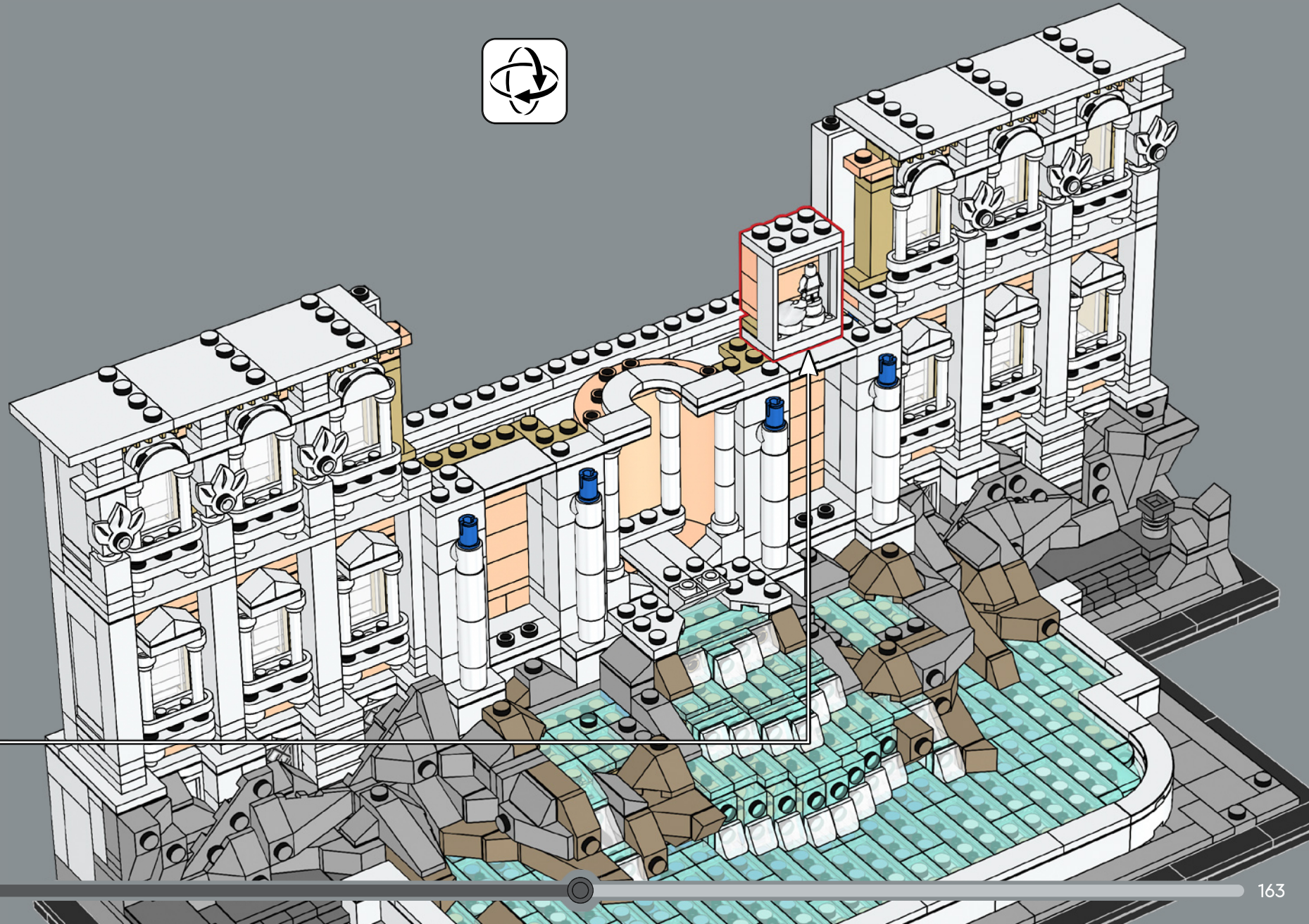

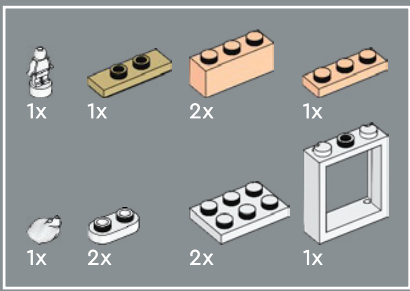

264

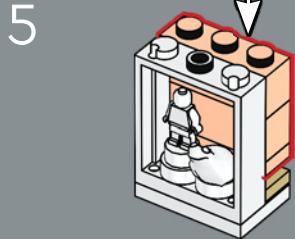
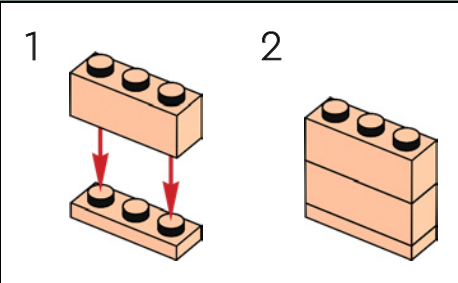
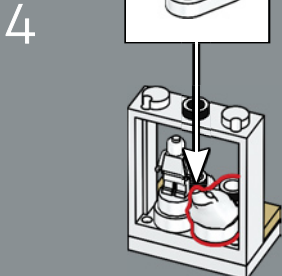
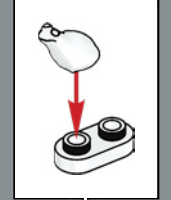
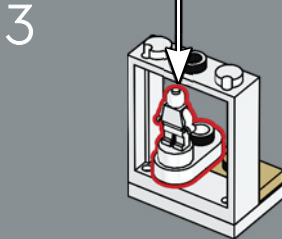
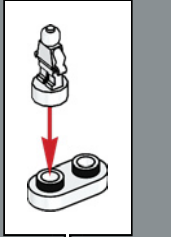
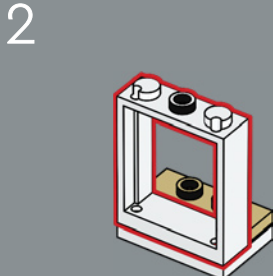
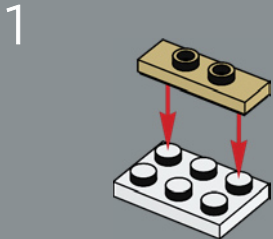

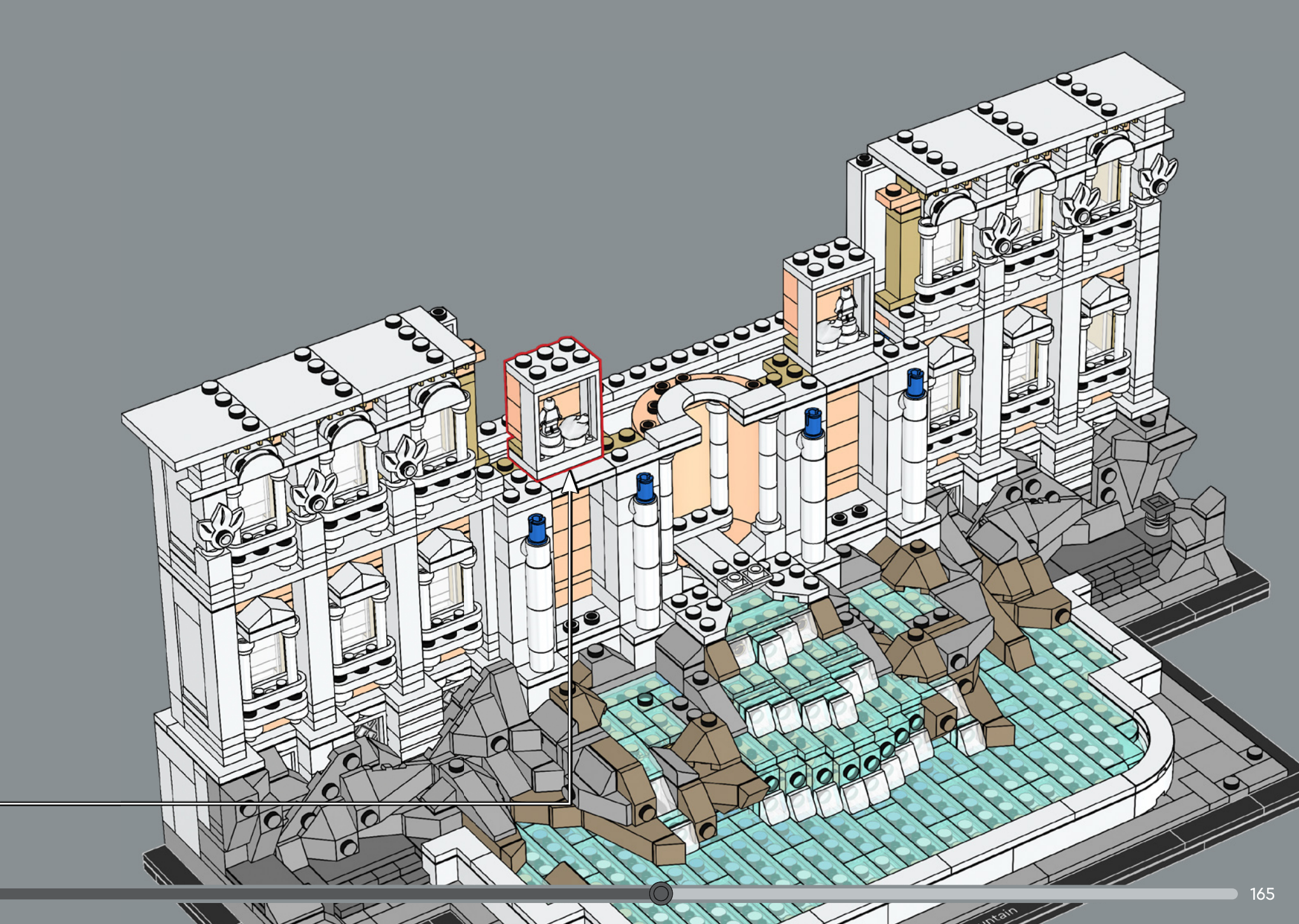

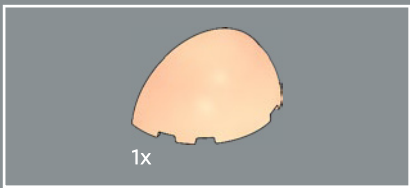

265

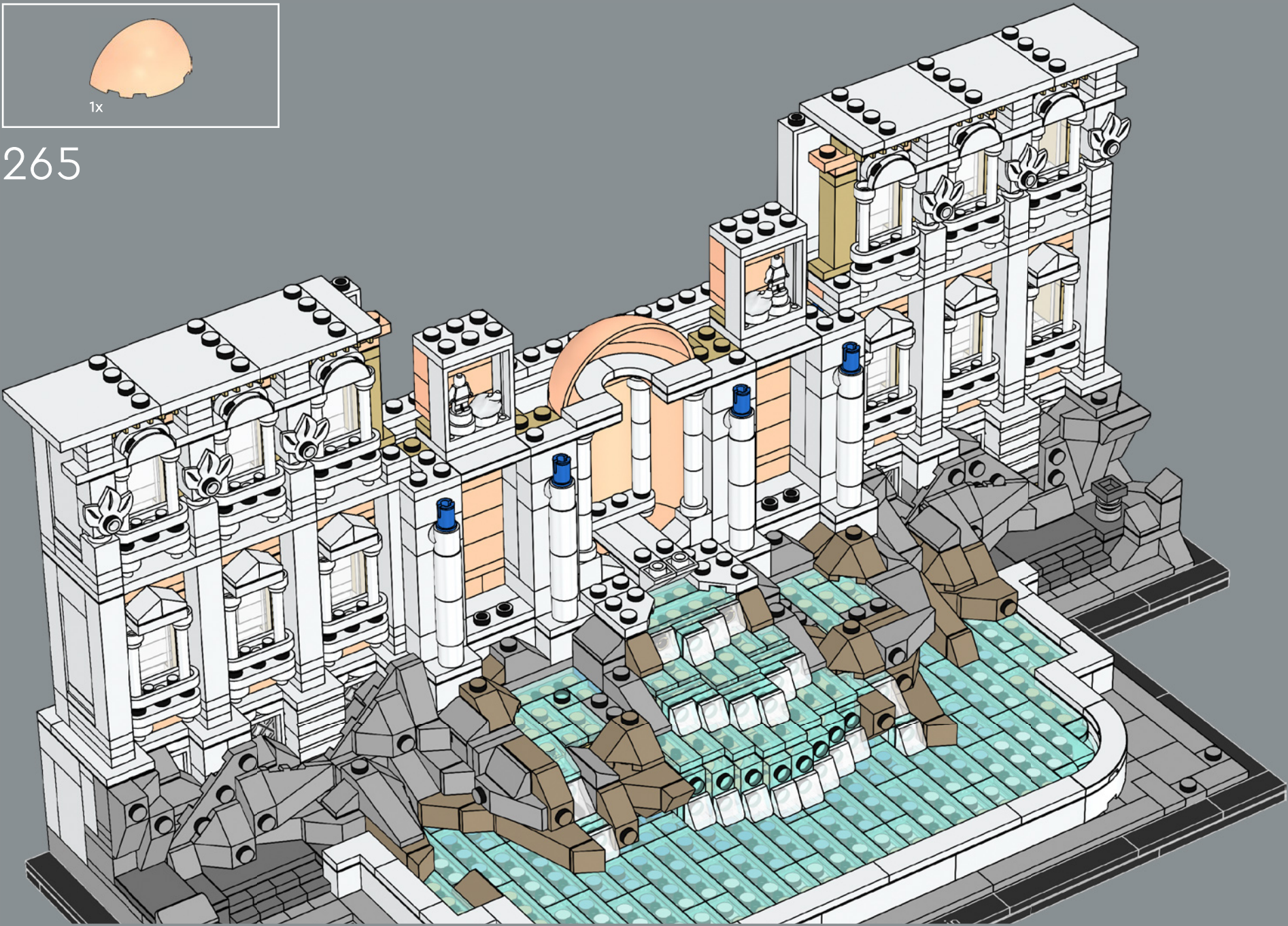

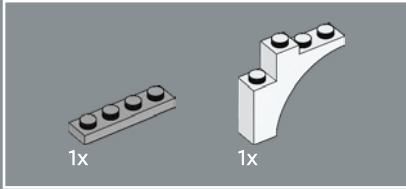
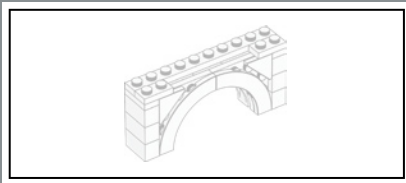

266

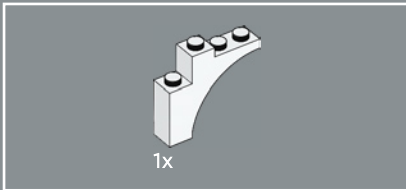
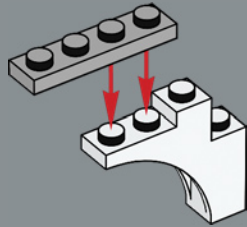

267

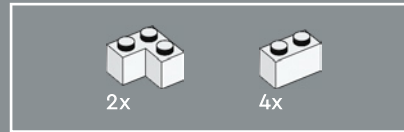
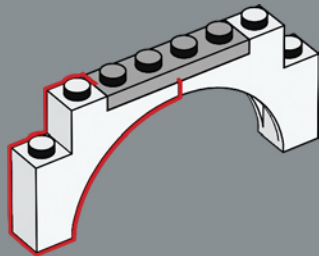

268

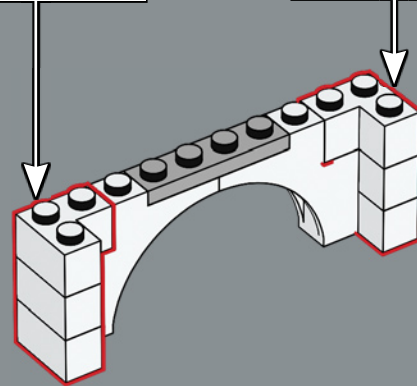
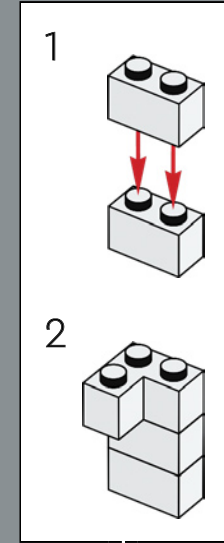
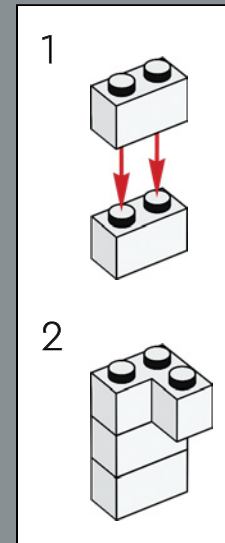

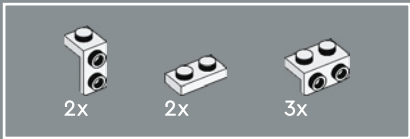

269

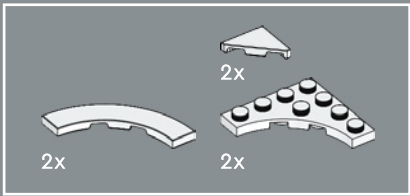
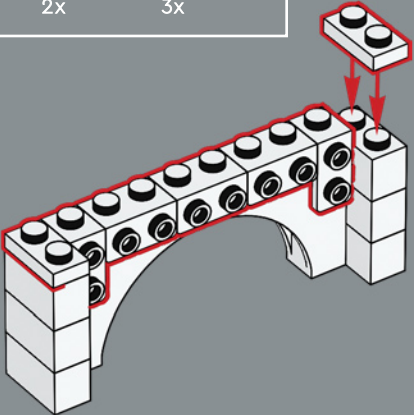

270

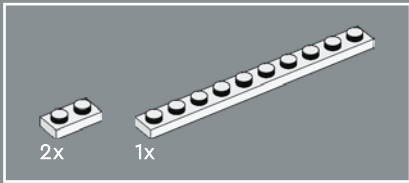
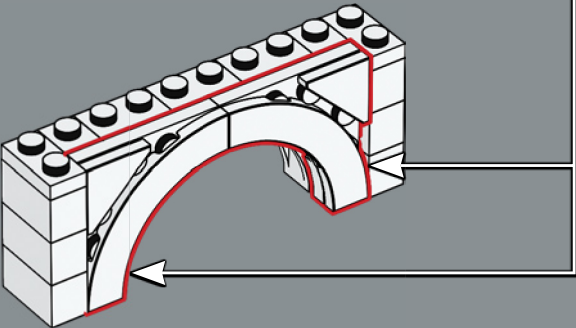
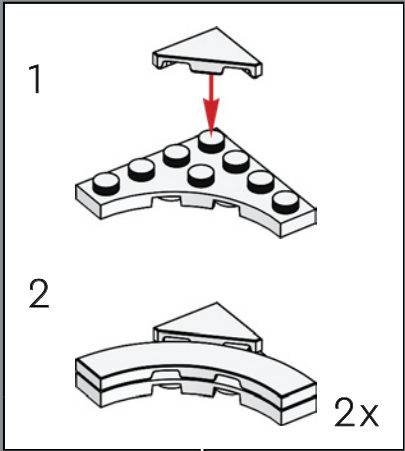

271

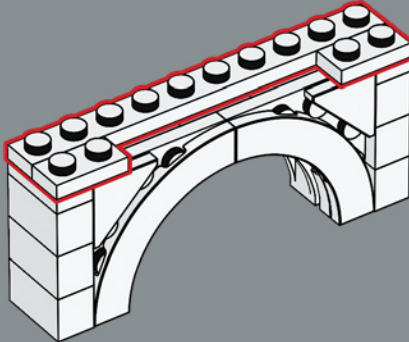



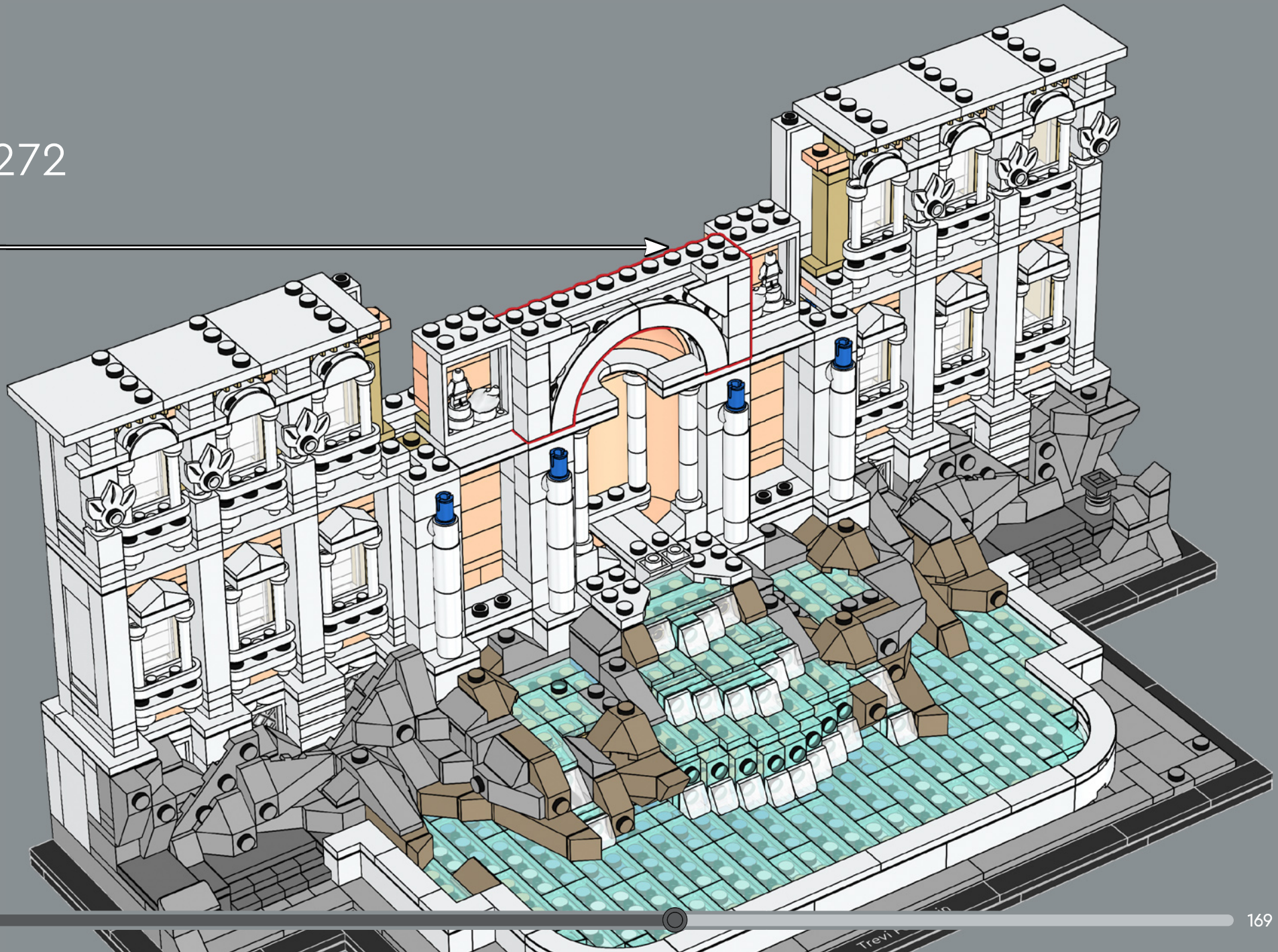

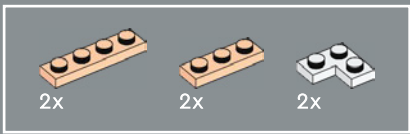

273

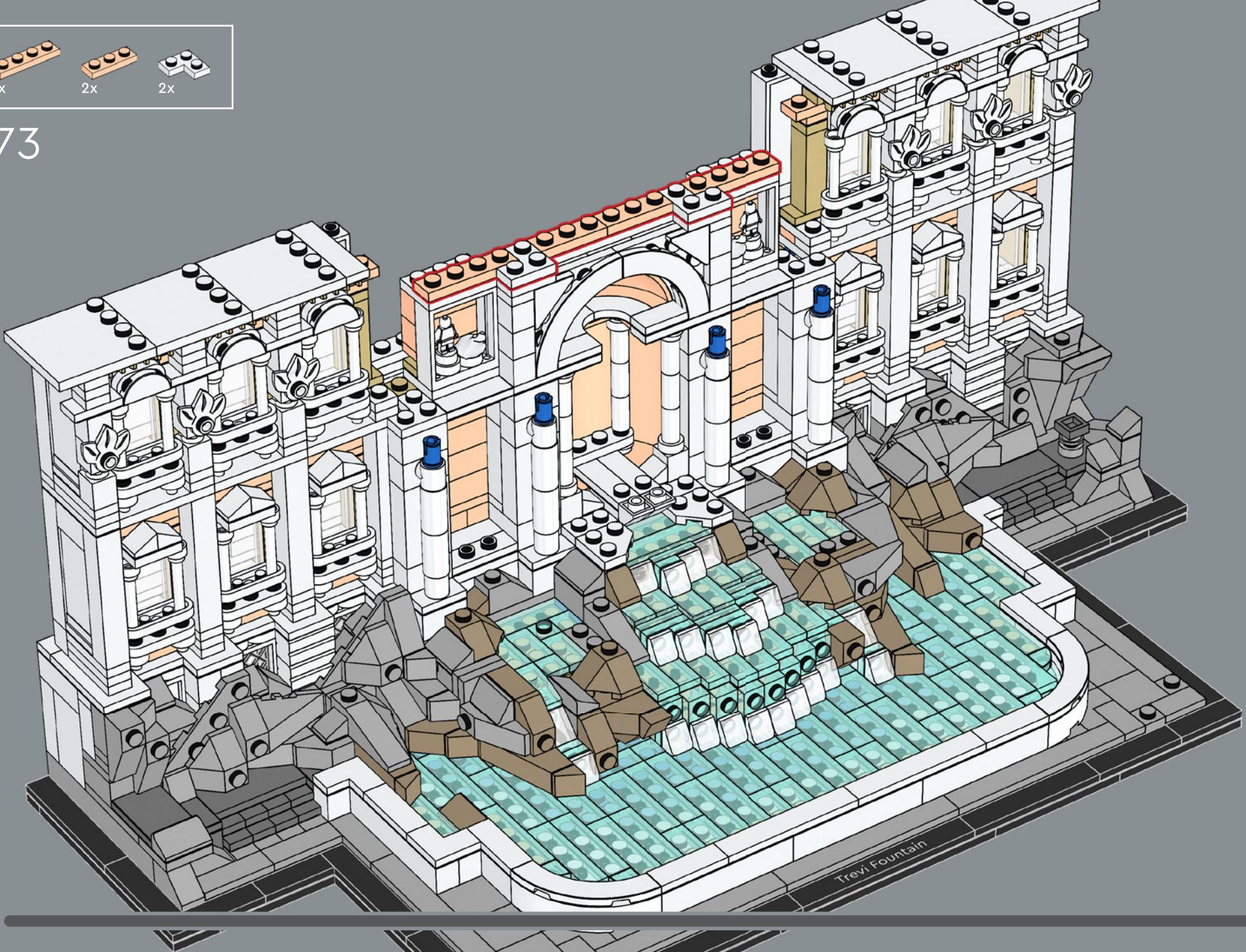

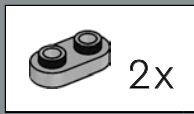
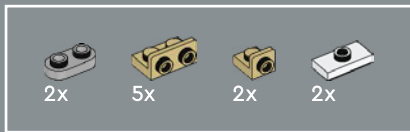

274

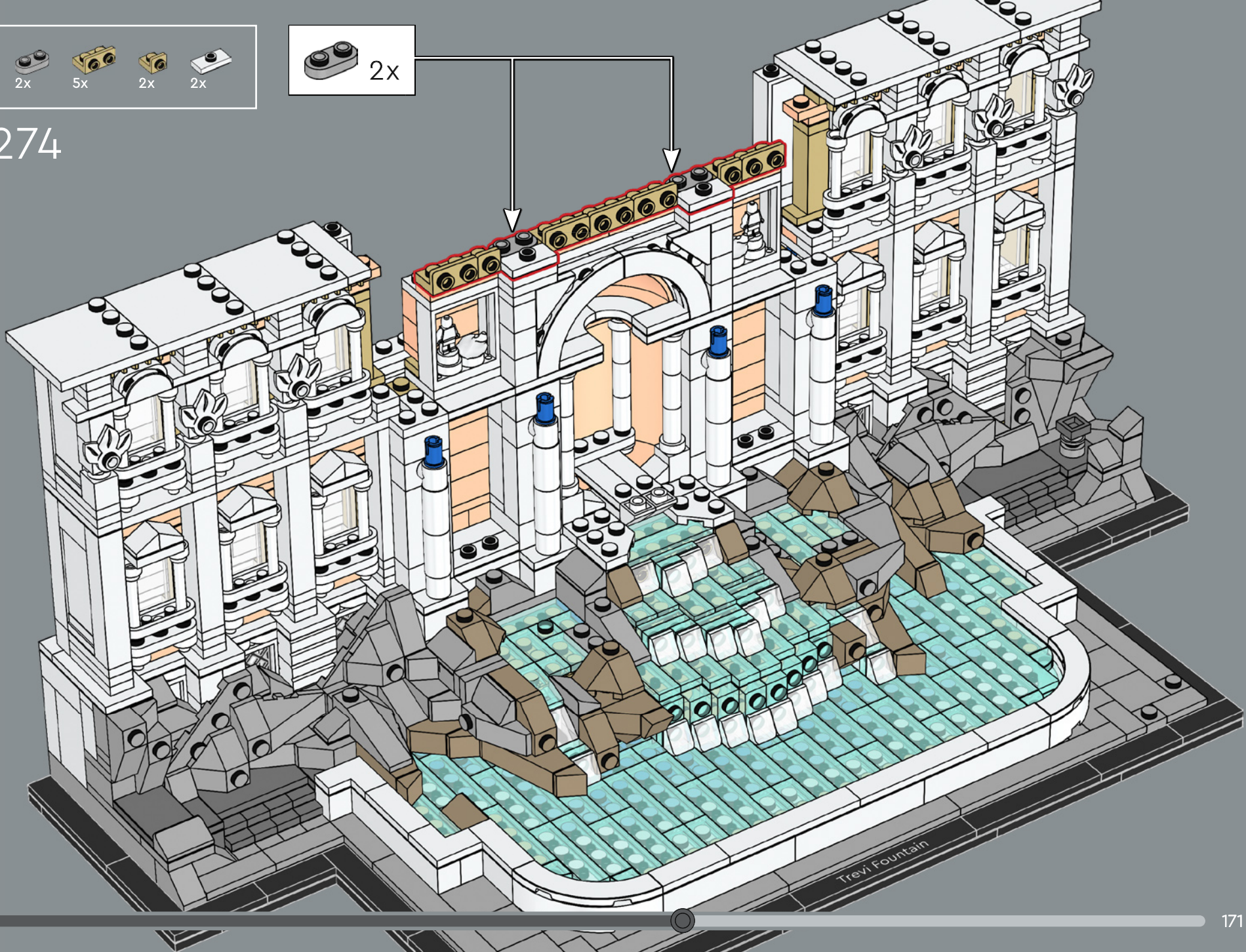

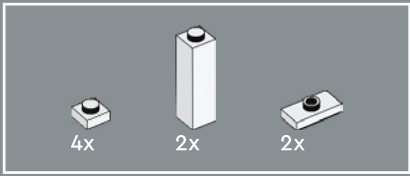

275

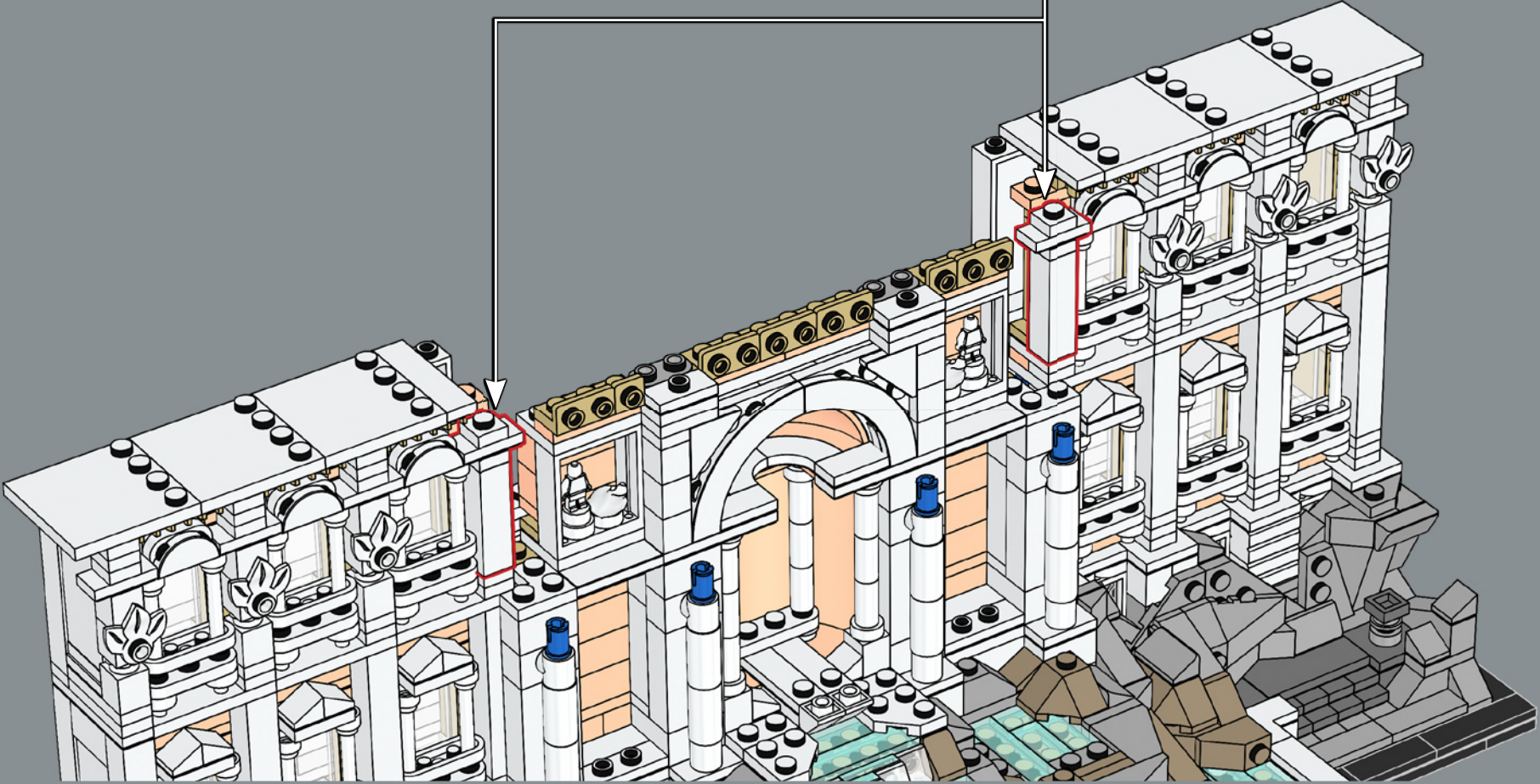
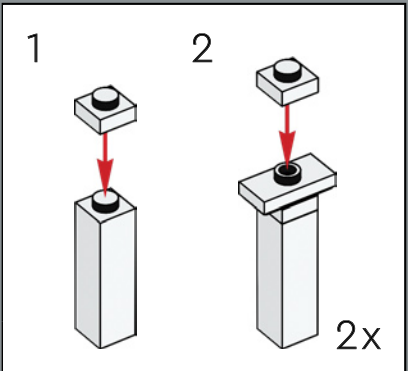

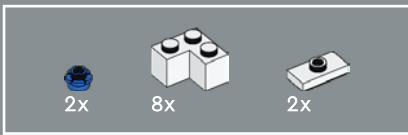

276

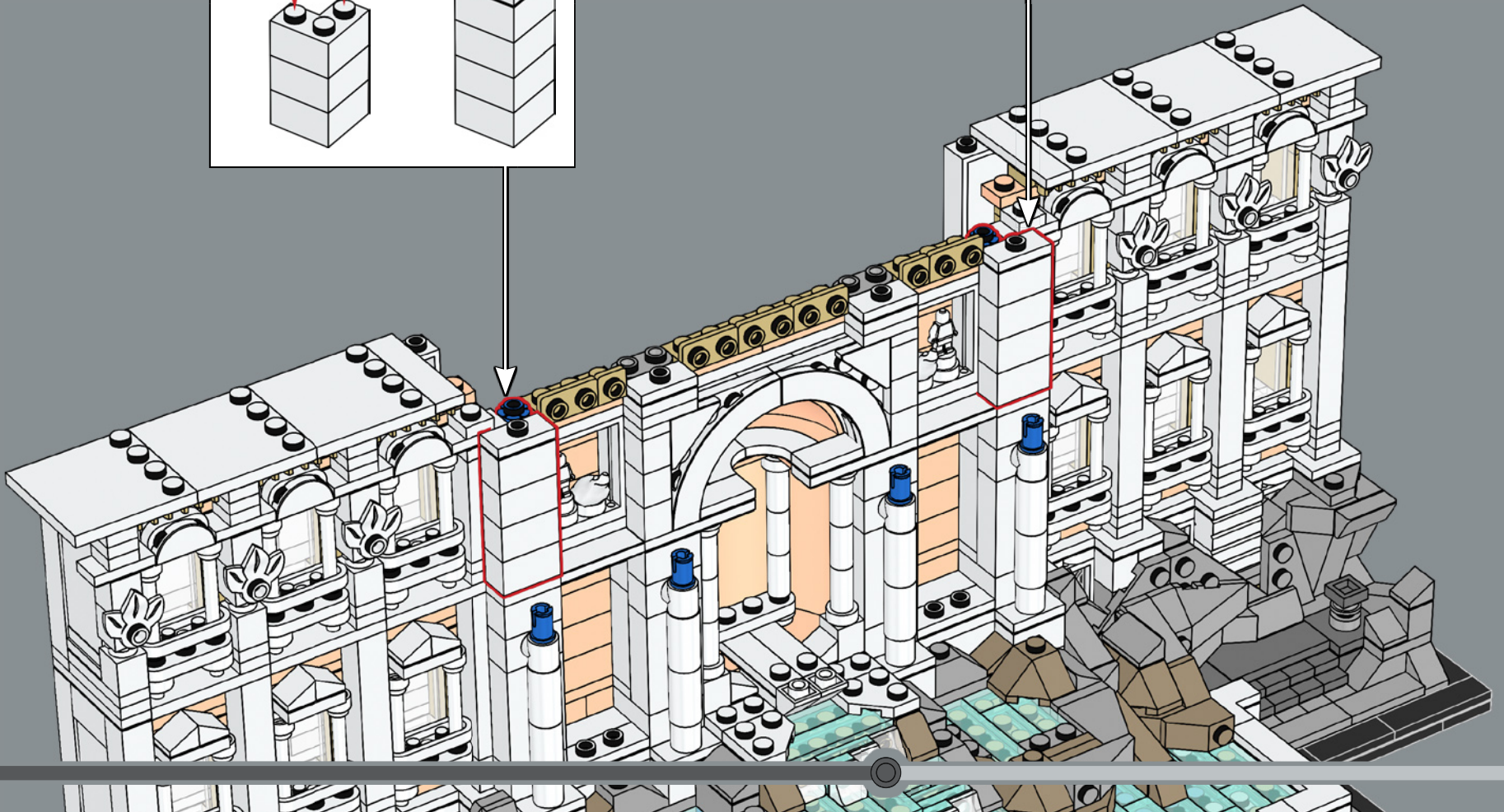
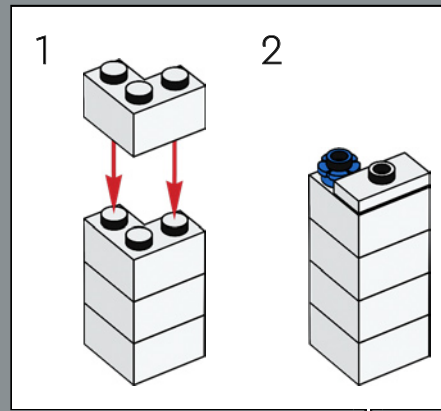
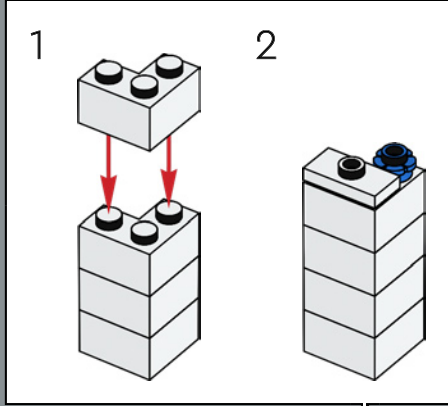



2x



277

1



3



2



4



5

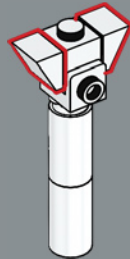

6

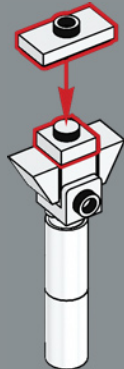

7

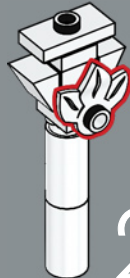

2x

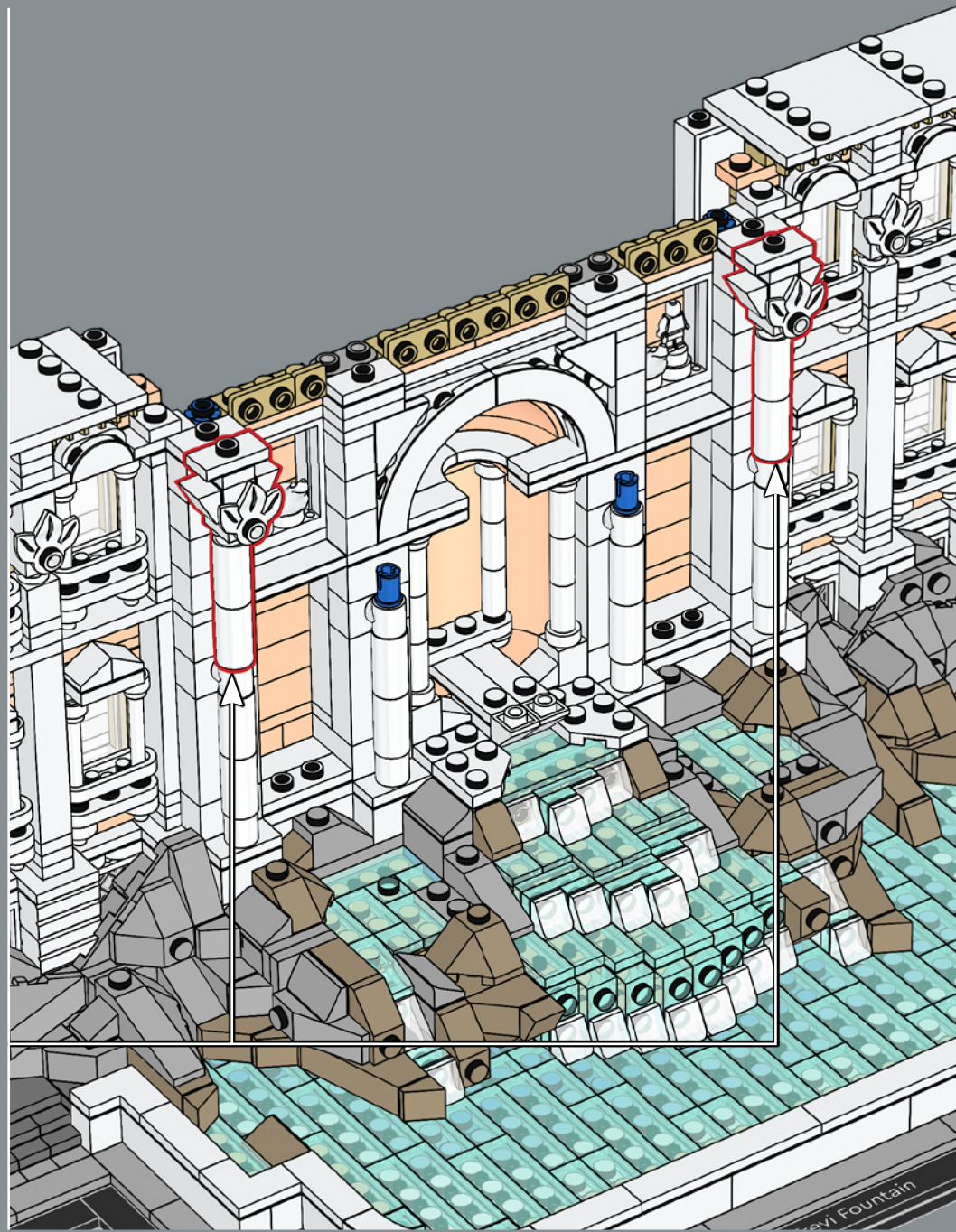

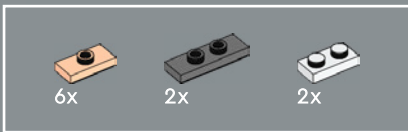

278

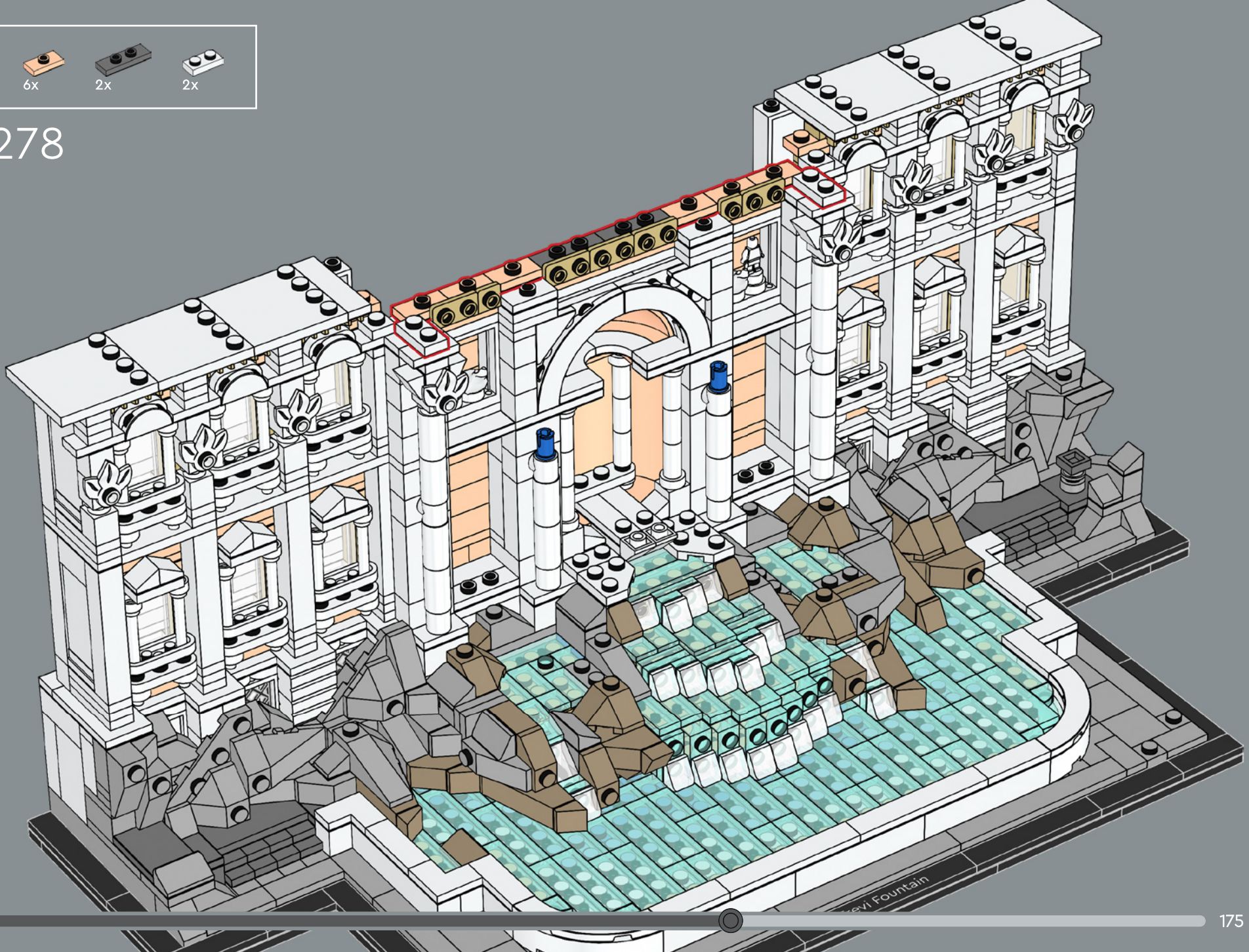

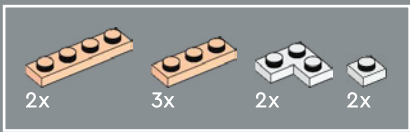

279

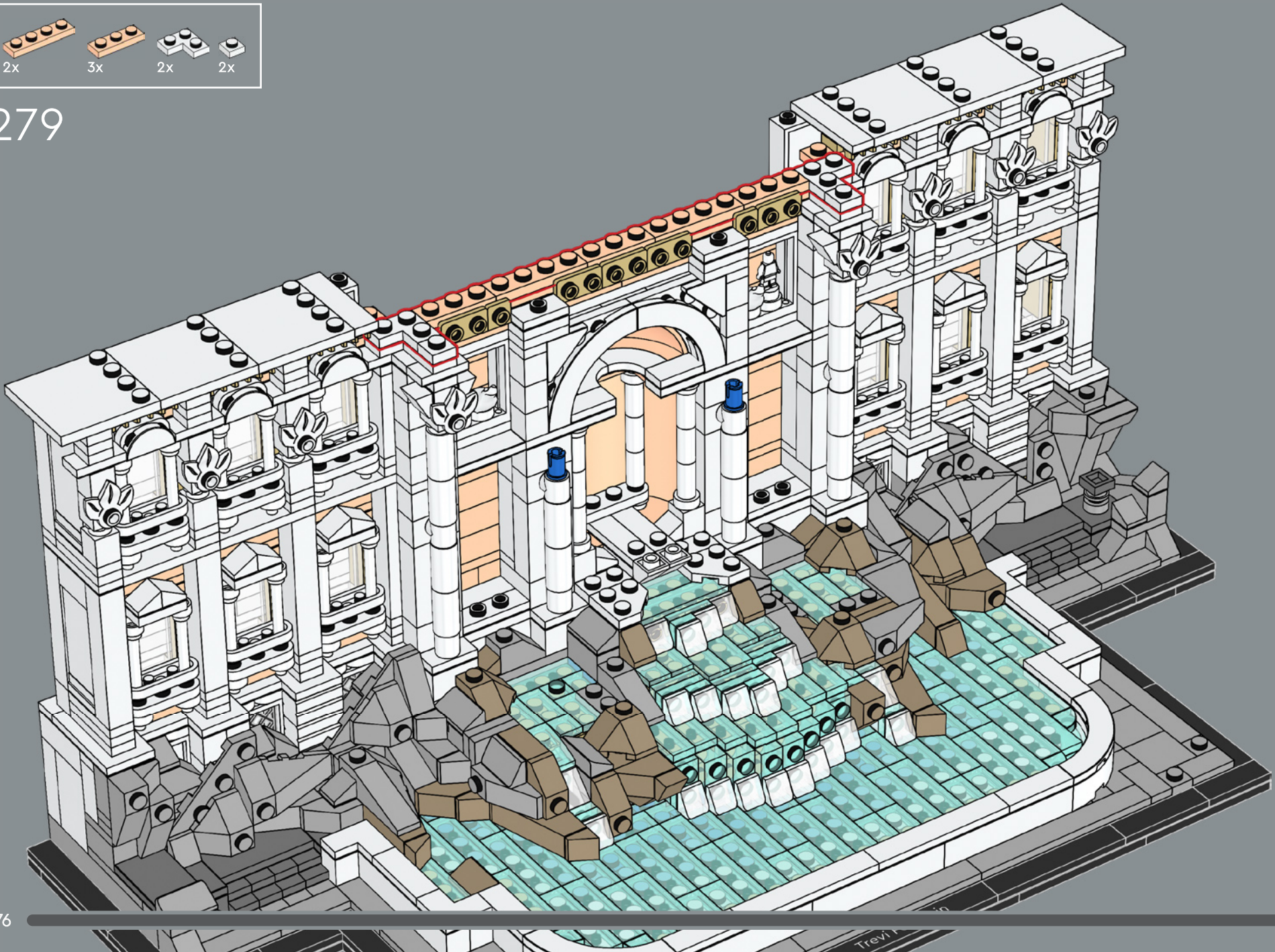



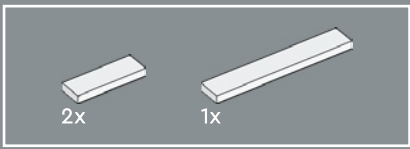

280

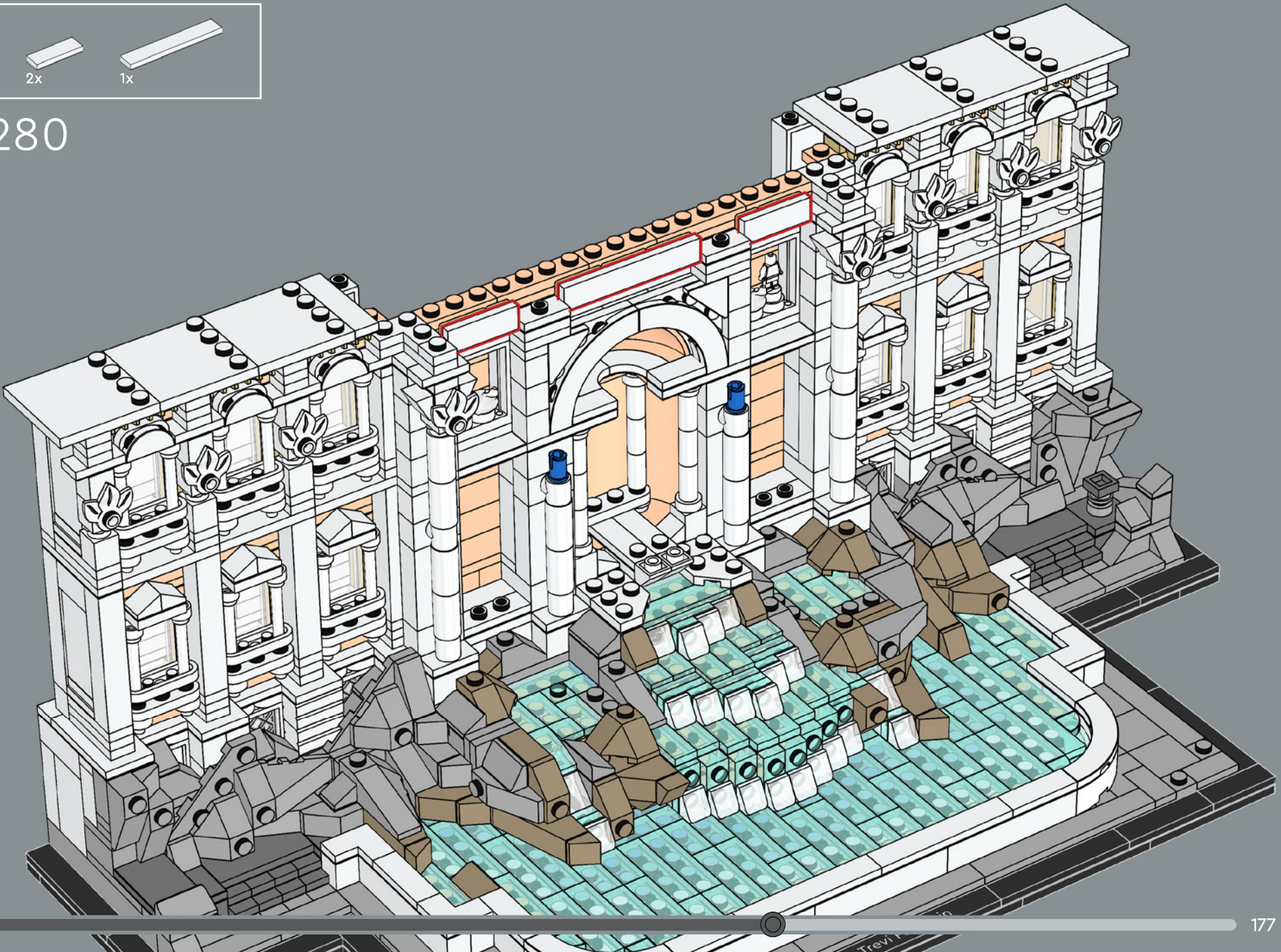



2x



281

1



2



3



4



5

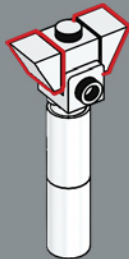

6

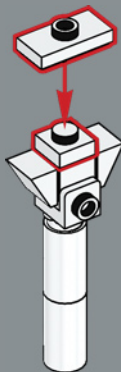

7

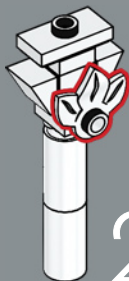

2x

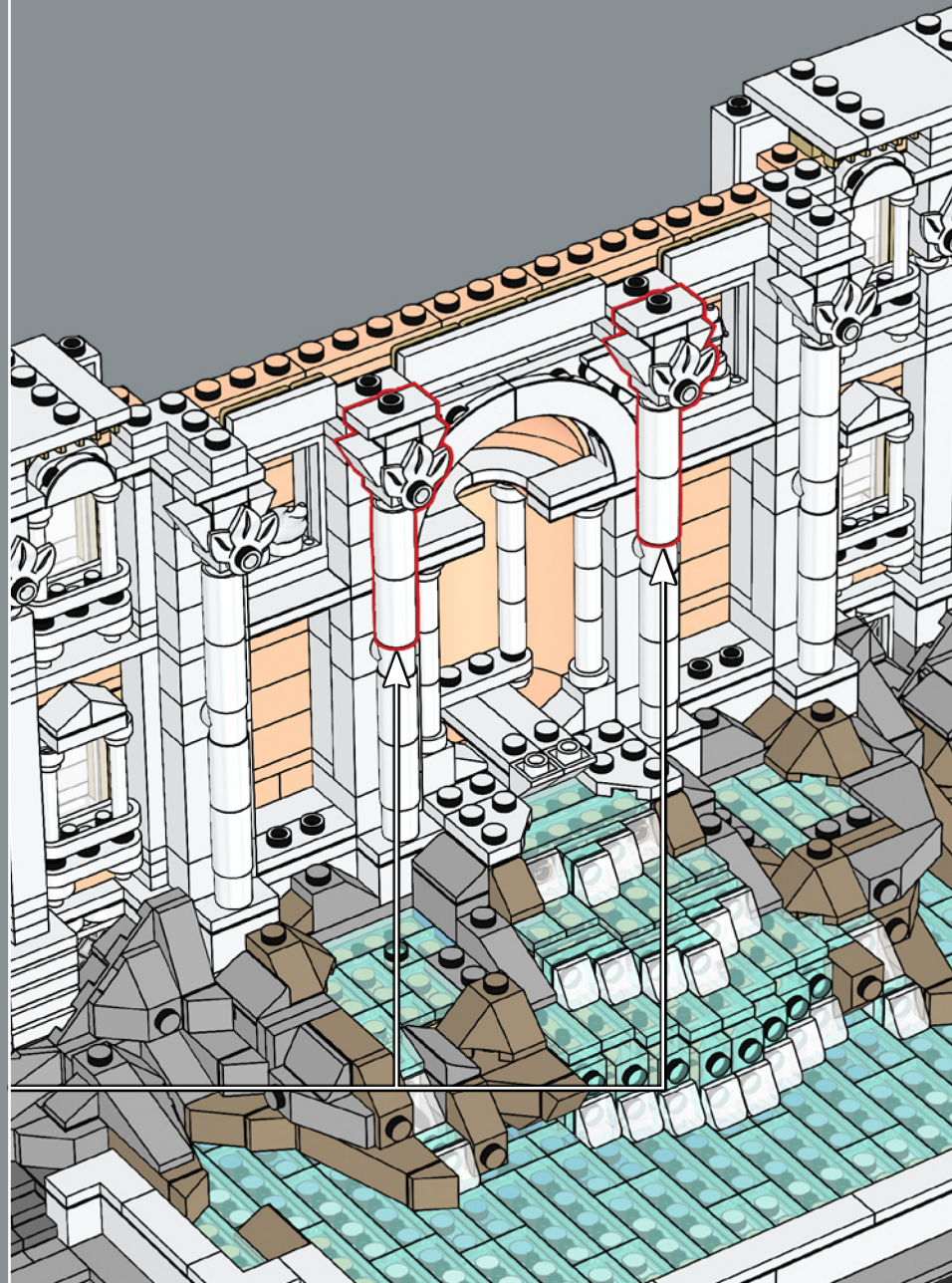

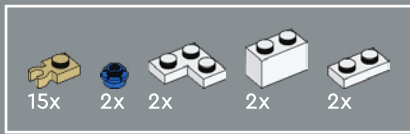

282

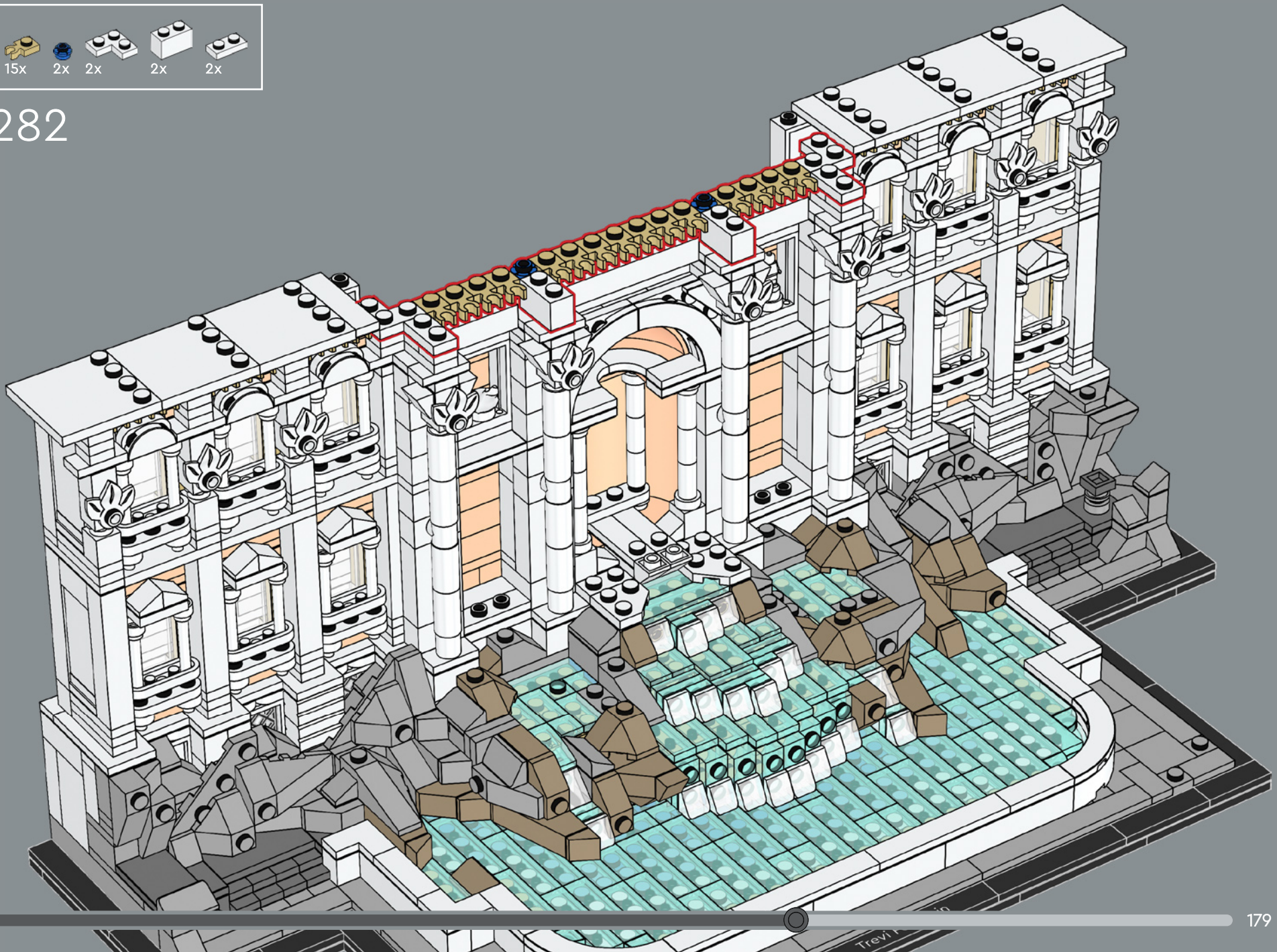

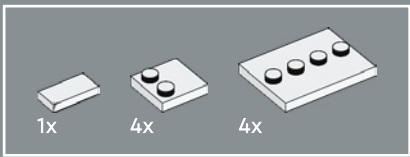

283

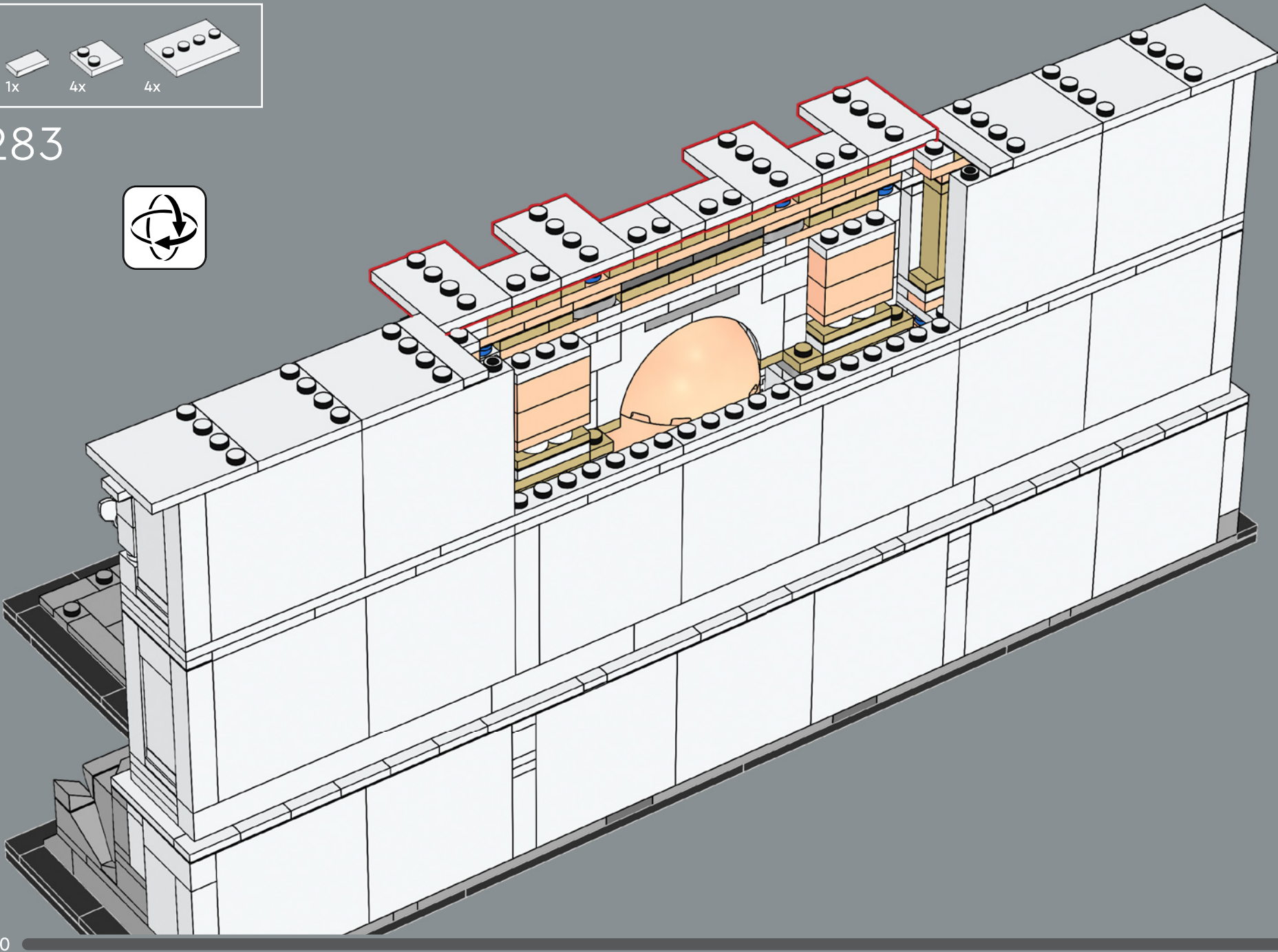

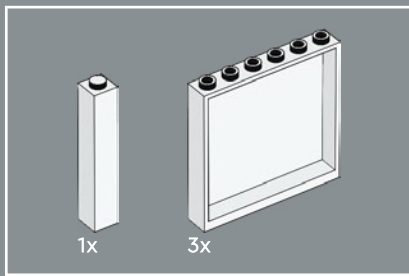

284

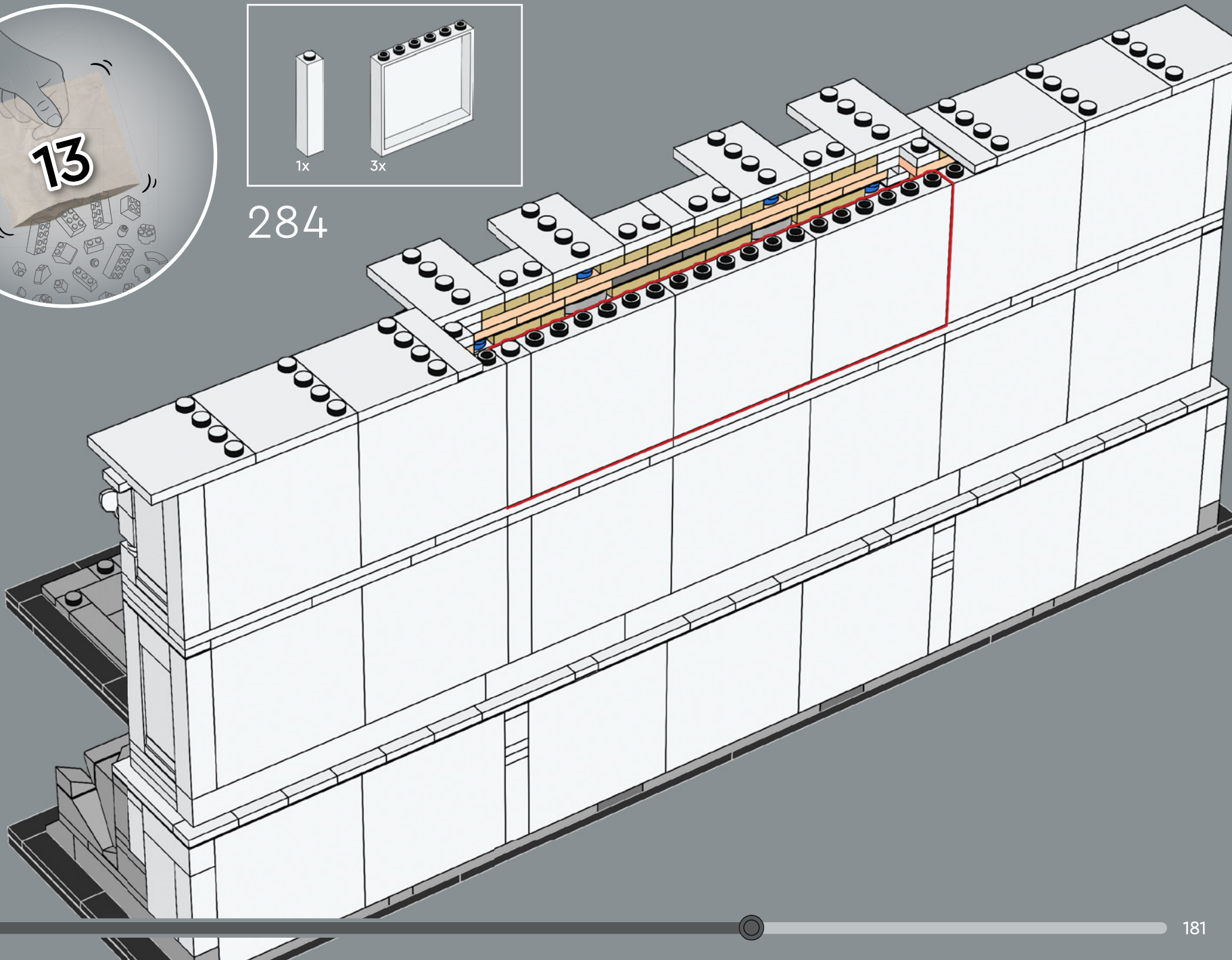

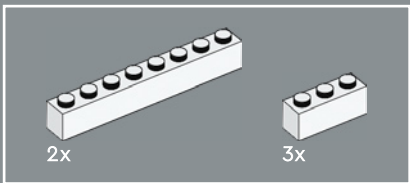

En la vida real, la Fontana di Trevi es la fachada del Palazzo Poli, una antigua residencia papal que ahora alberga un museo. El edificio continúa hacia atrás con una arquitectura que armoniza con los edificios circundantes en lugar de mantener el estilo barroco de la fuente.

285

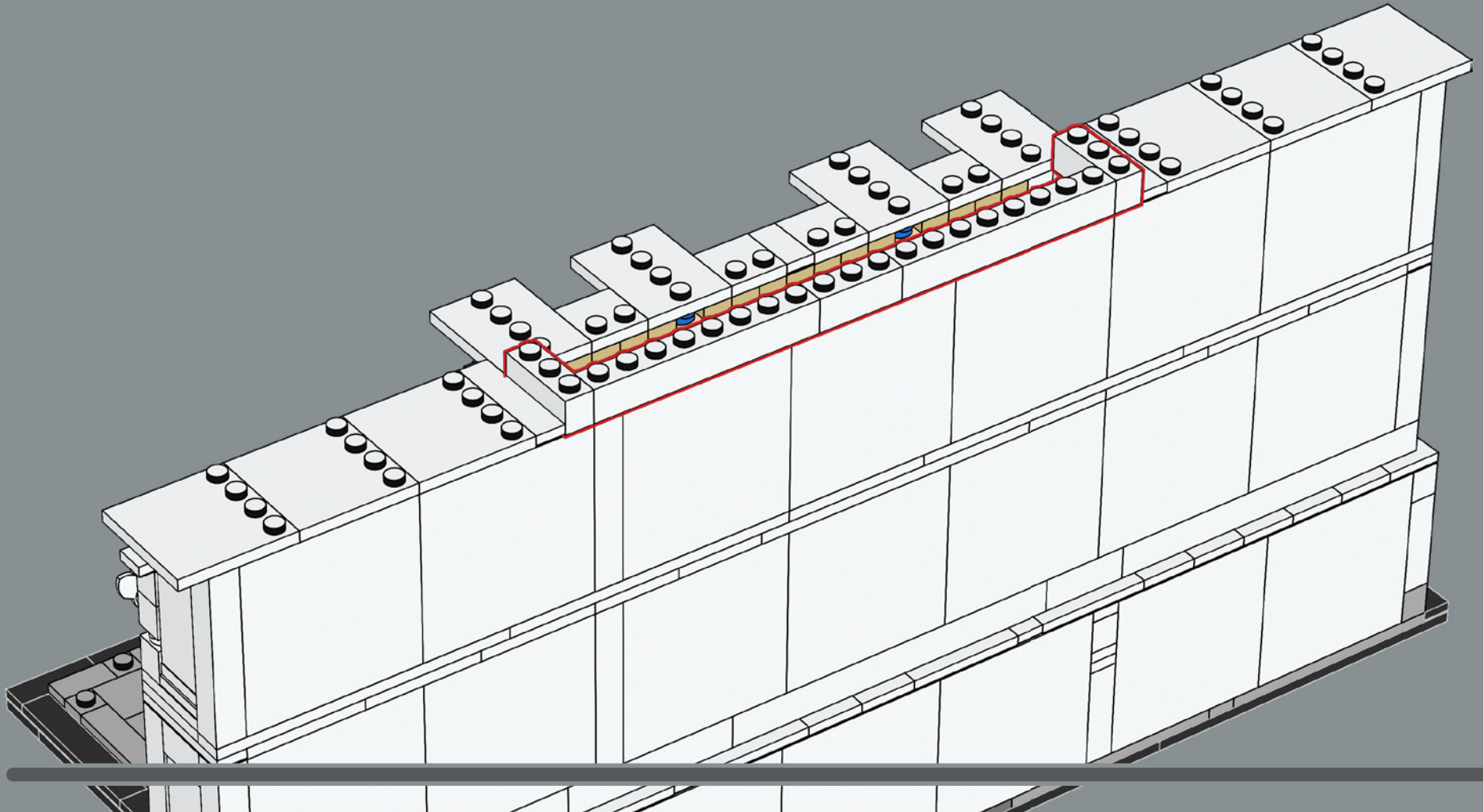

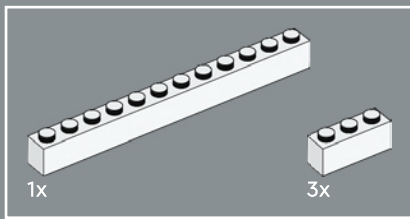

286

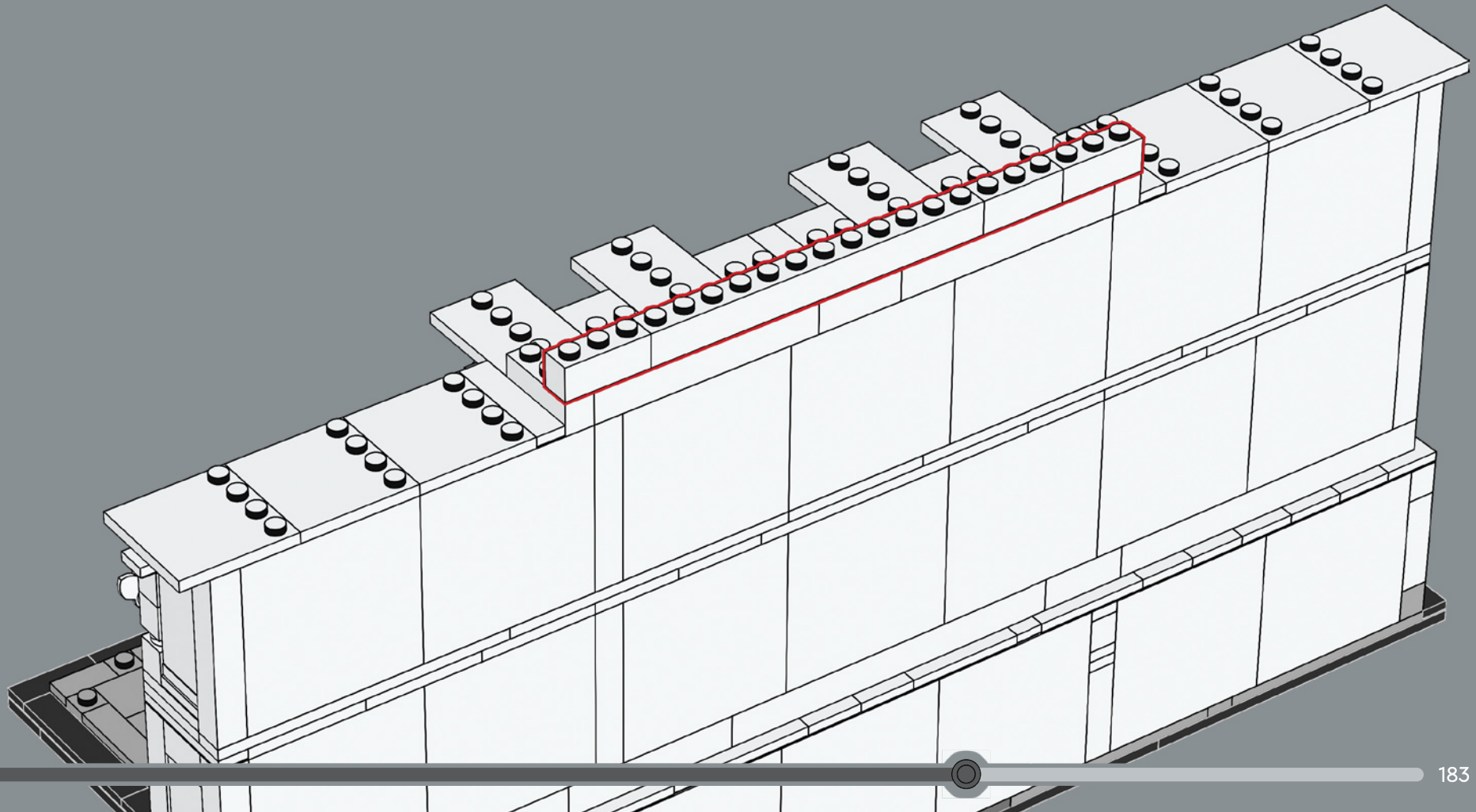

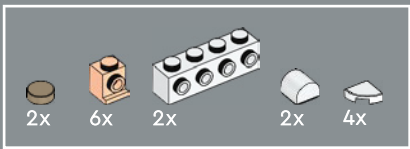

287

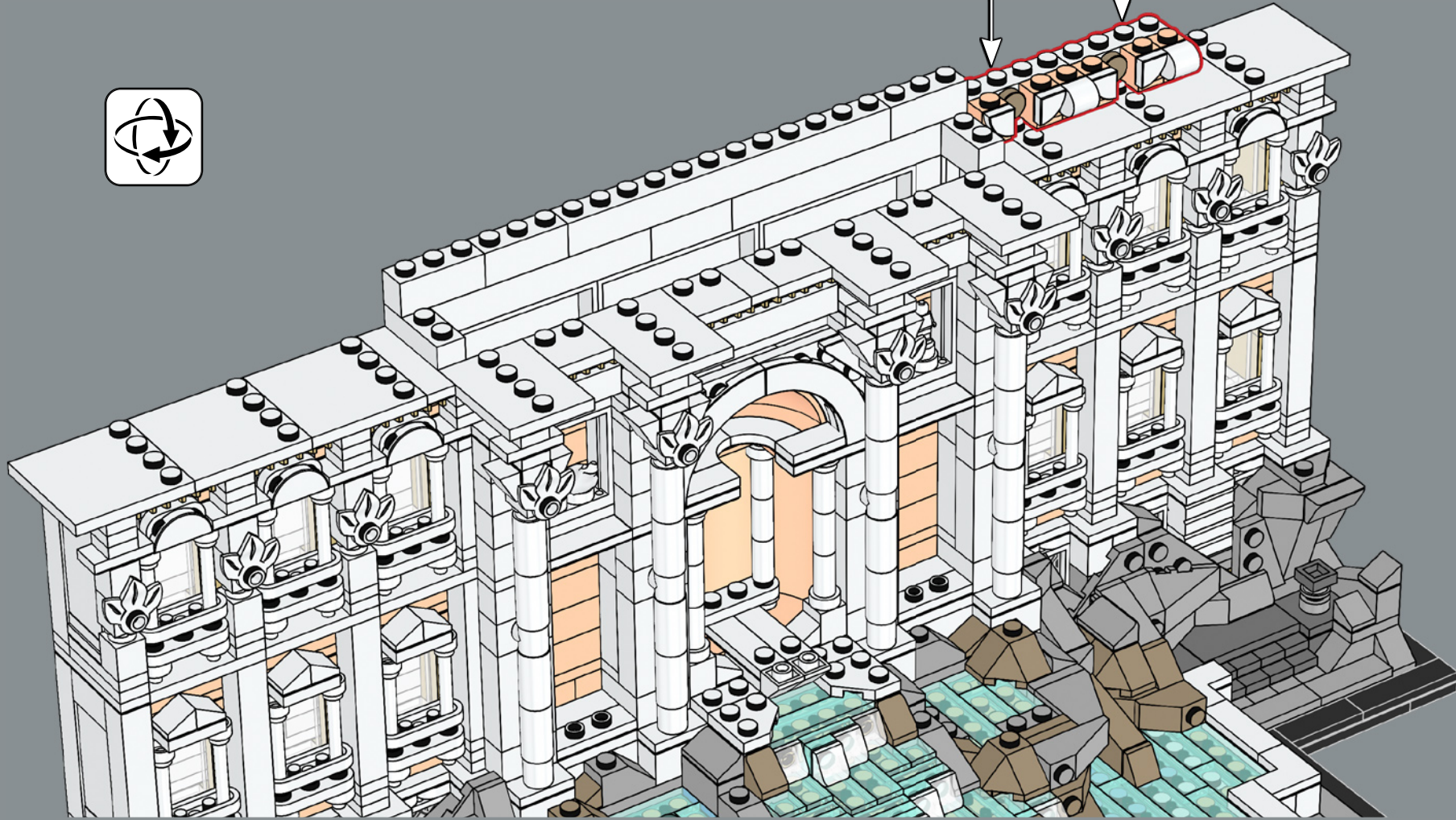
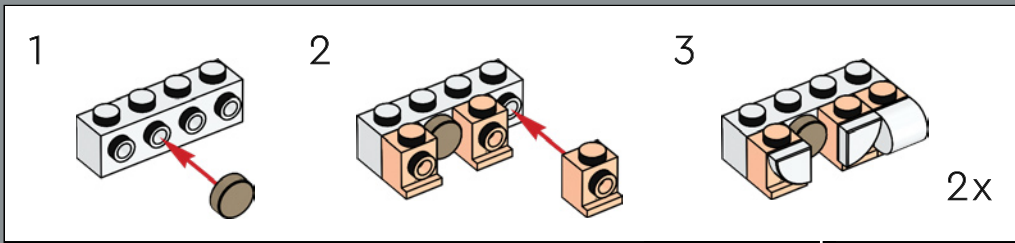



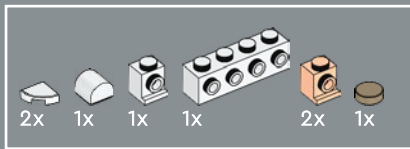

288

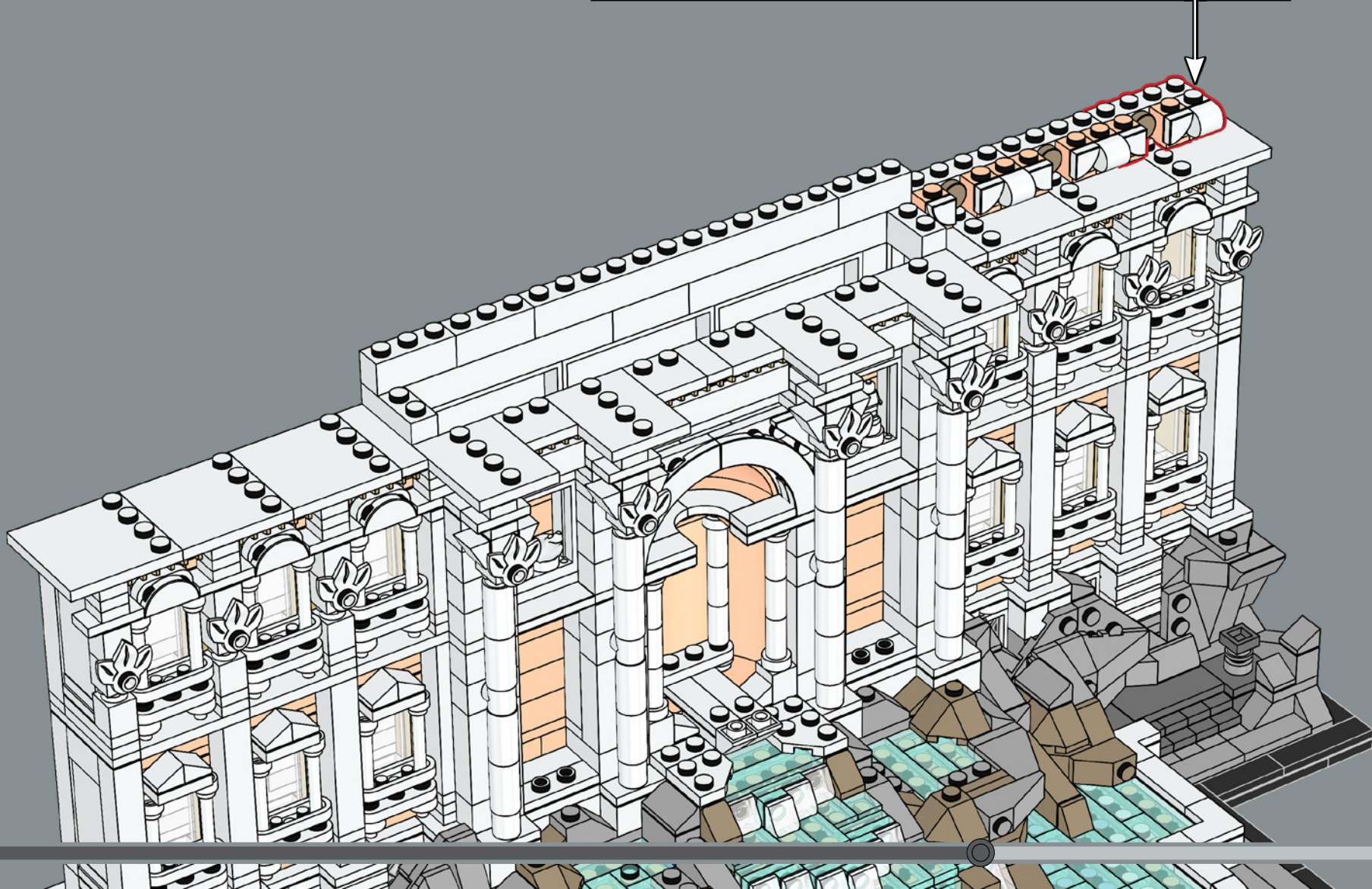
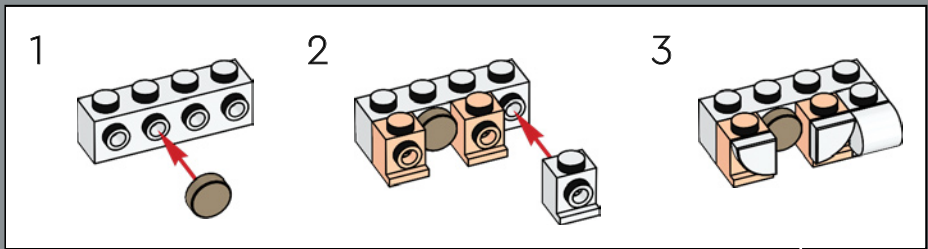

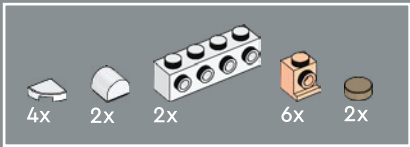

289

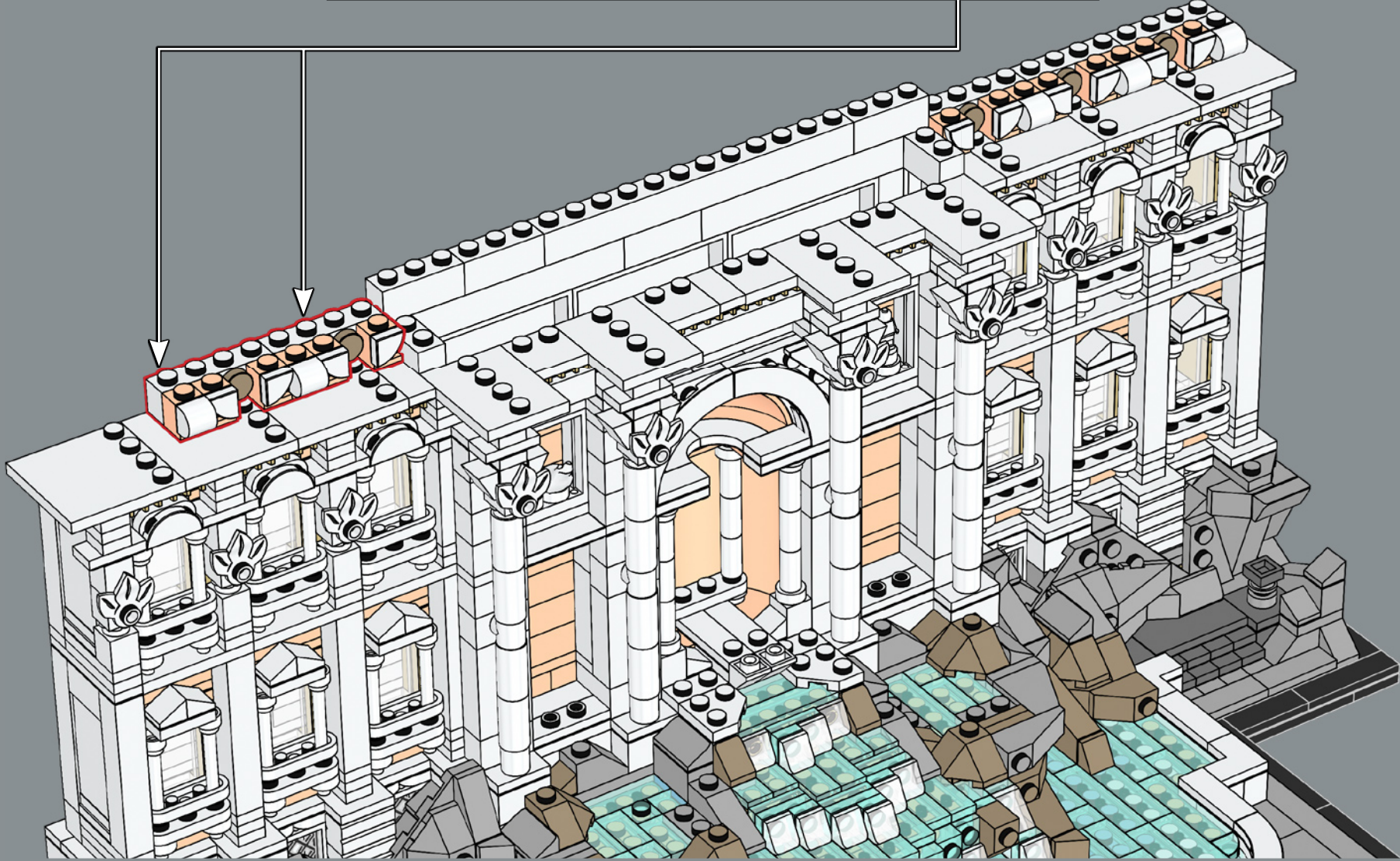
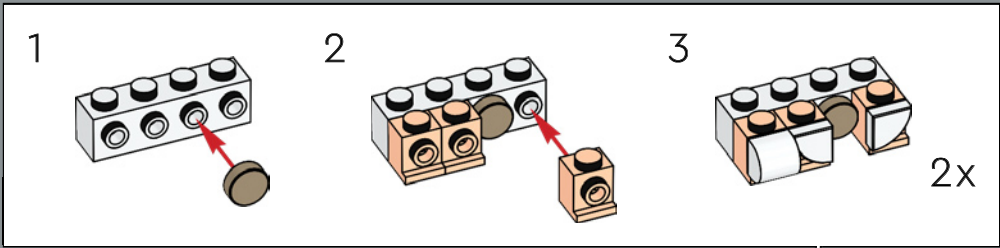

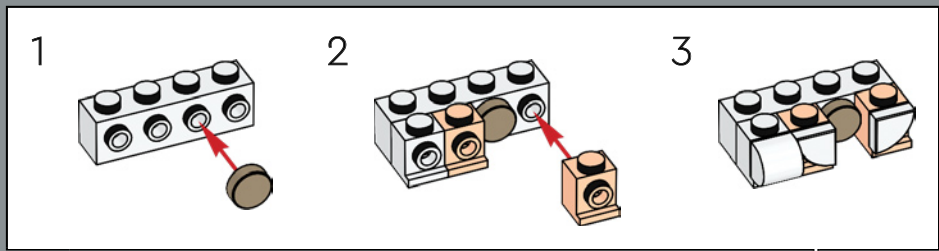
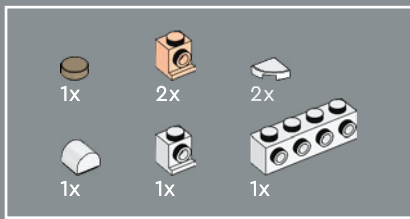

290

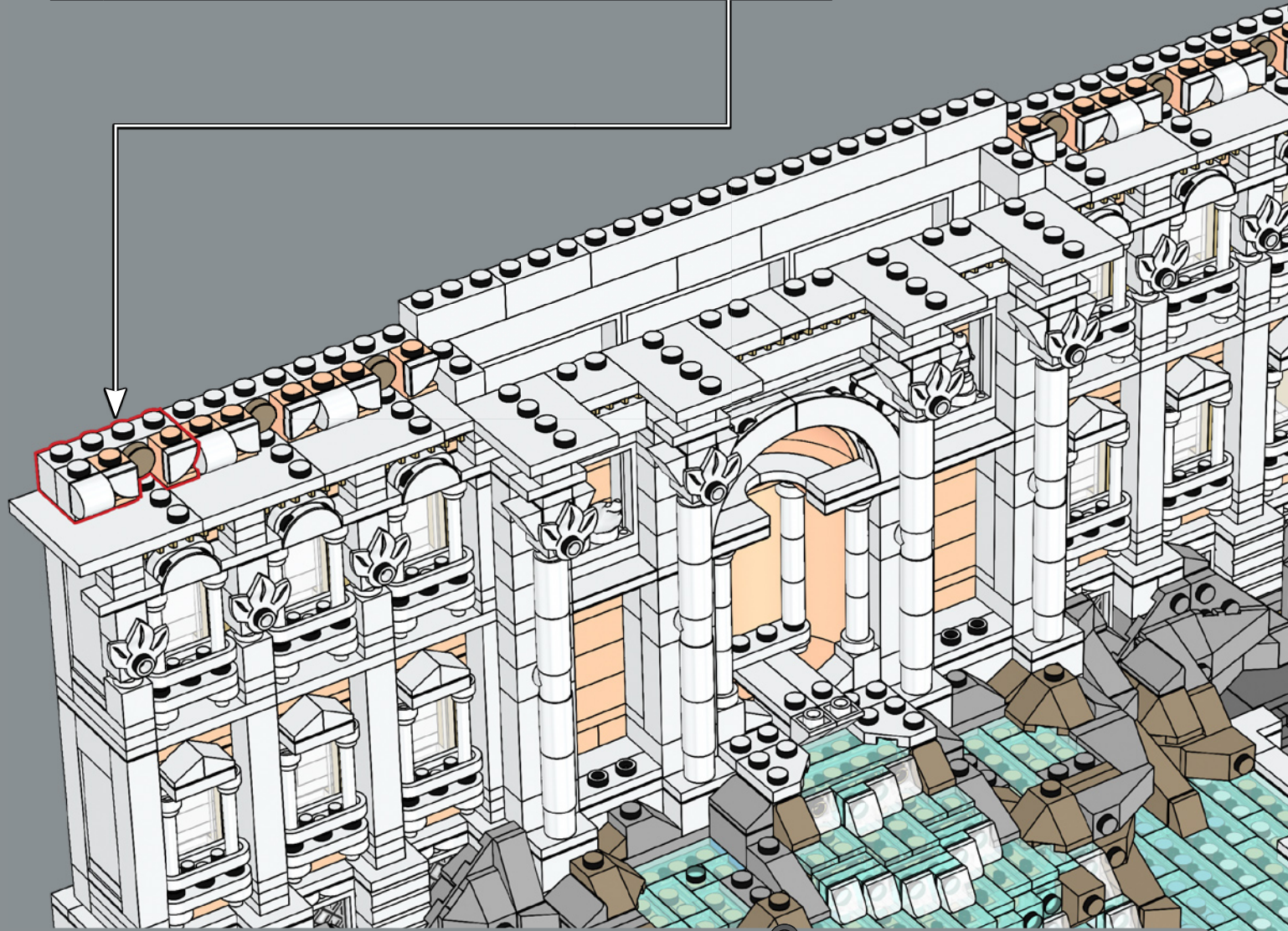



6x

291

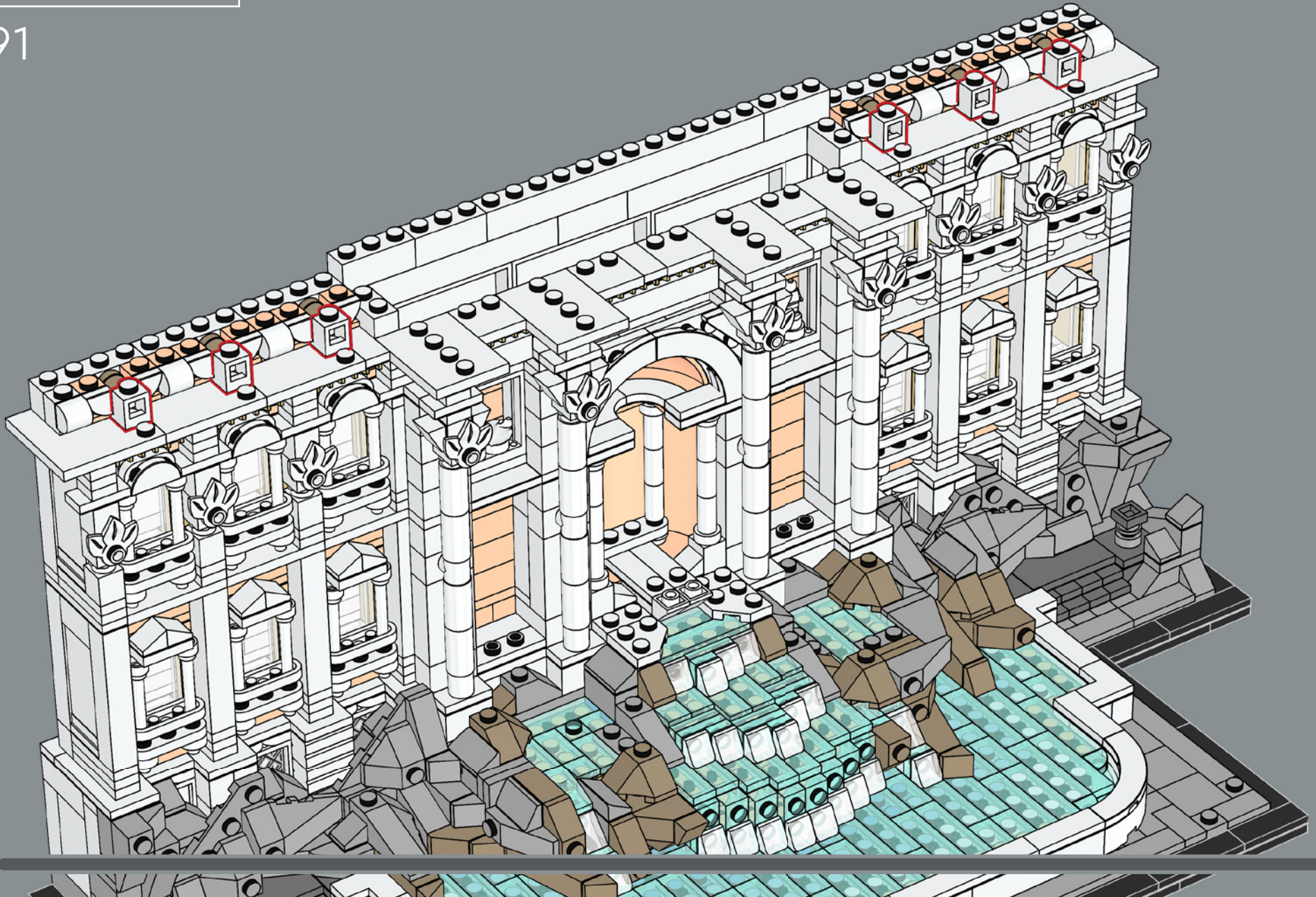

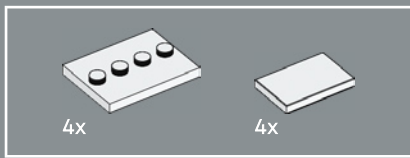

292

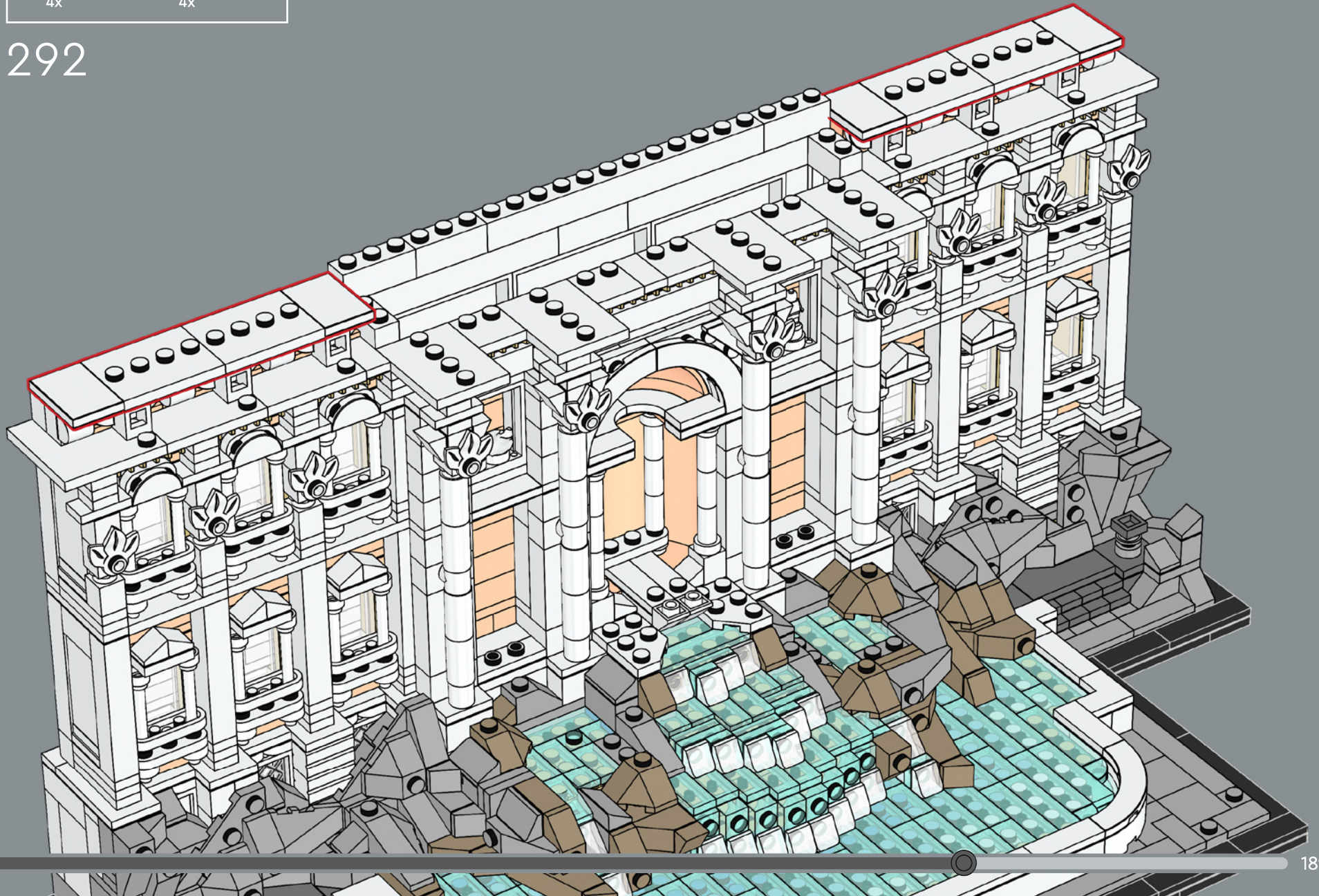

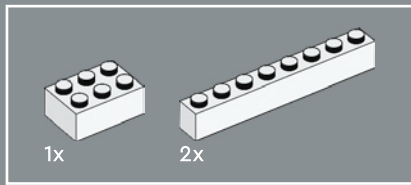

293

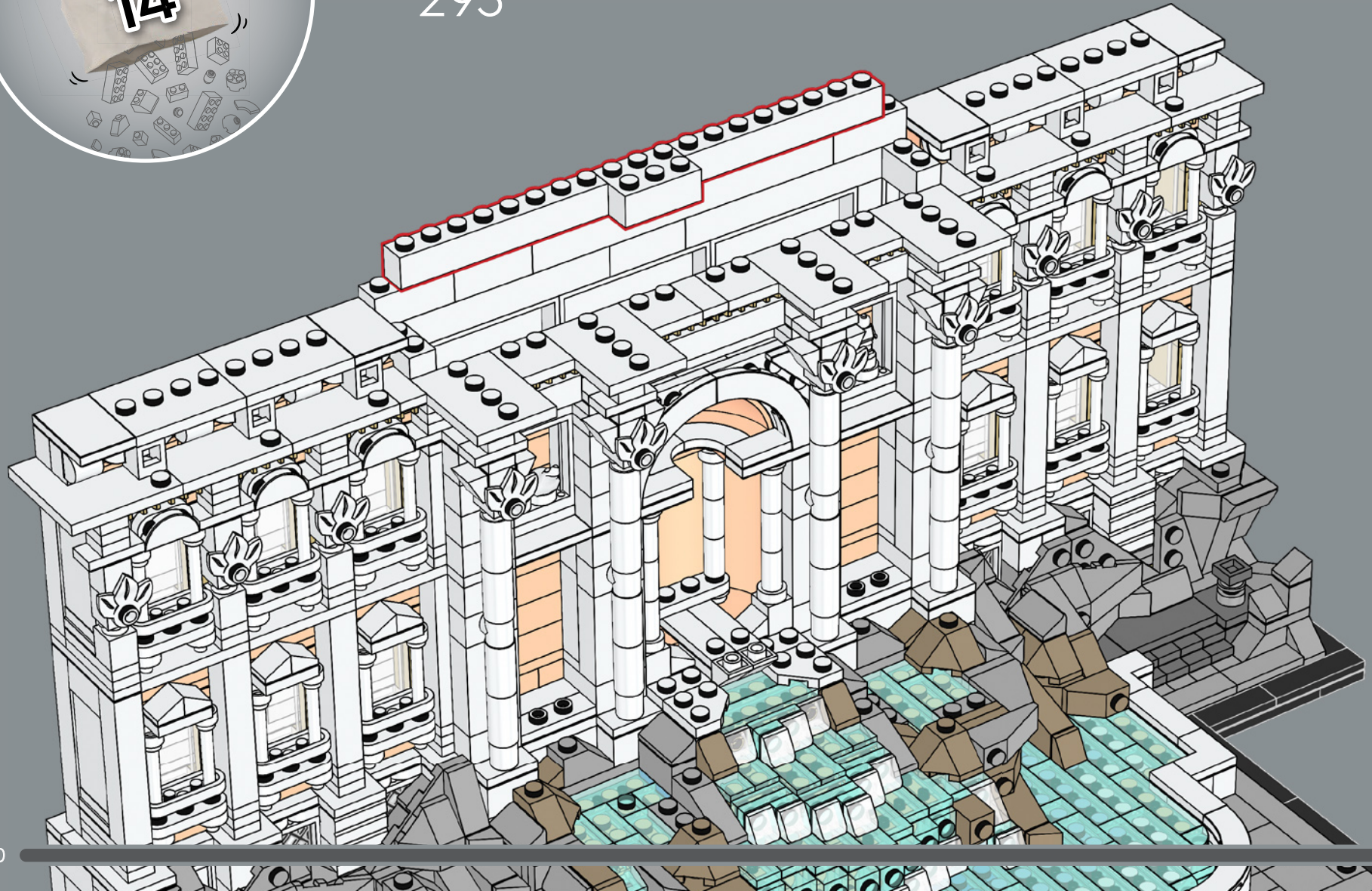

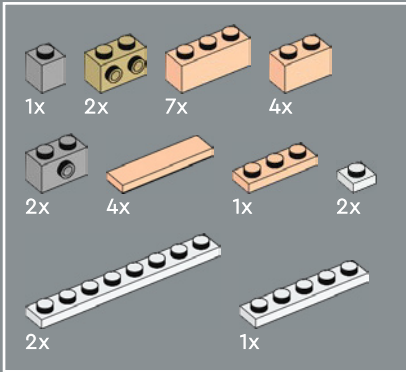
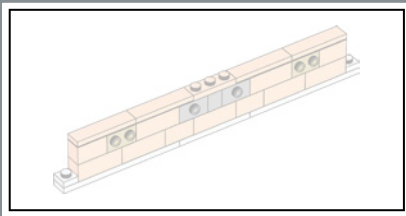

294

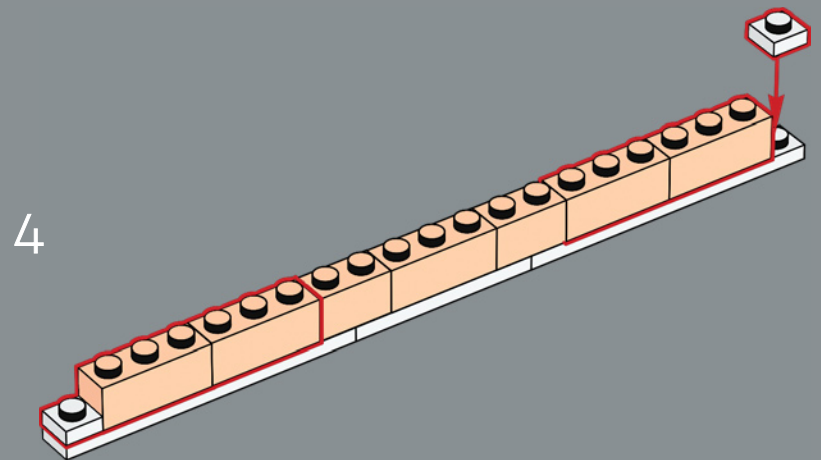
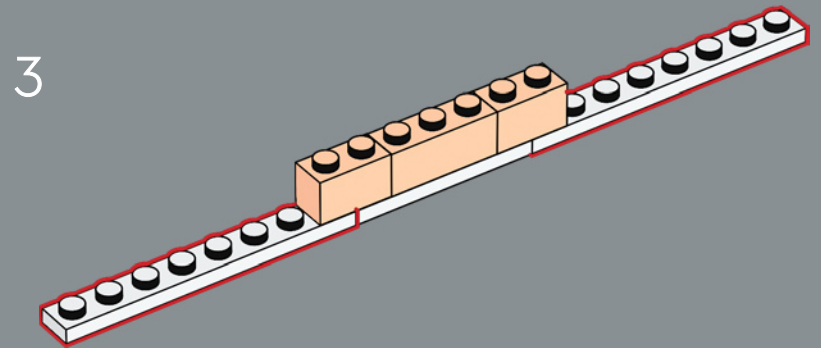
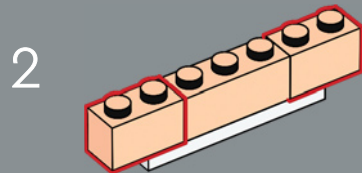
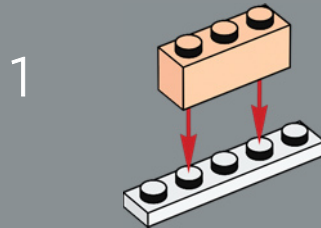

5

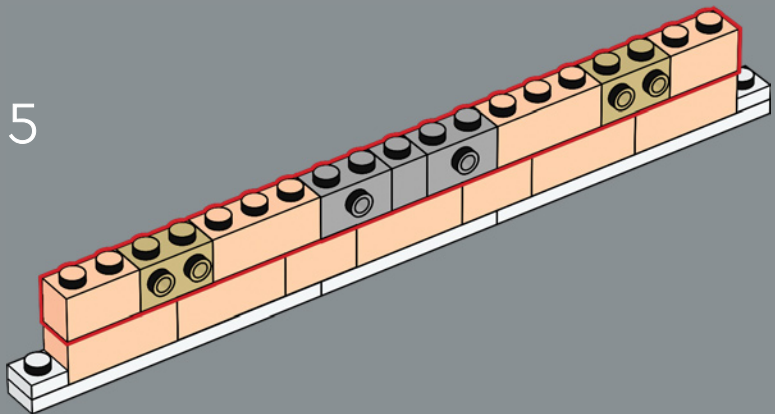

6

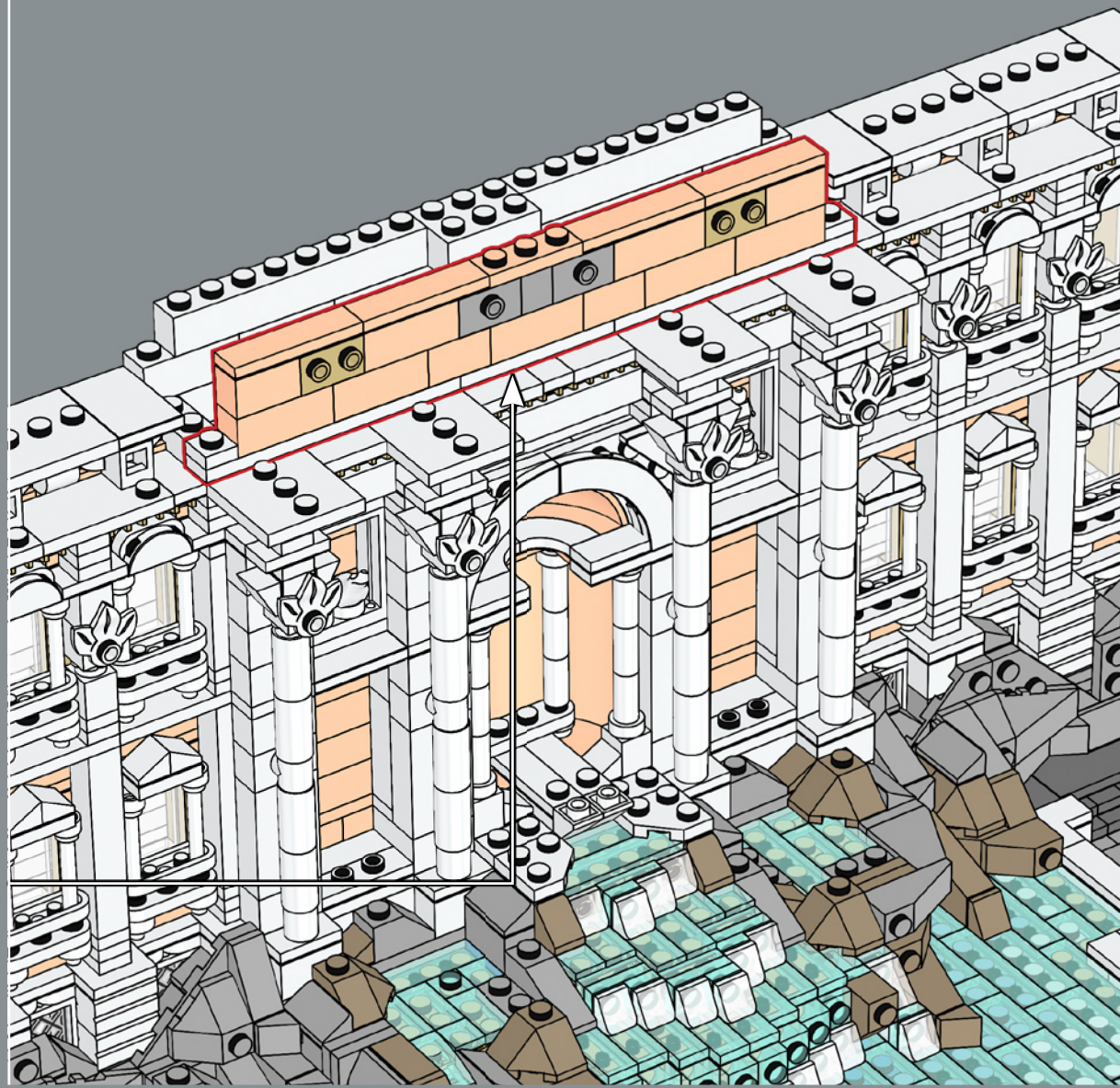
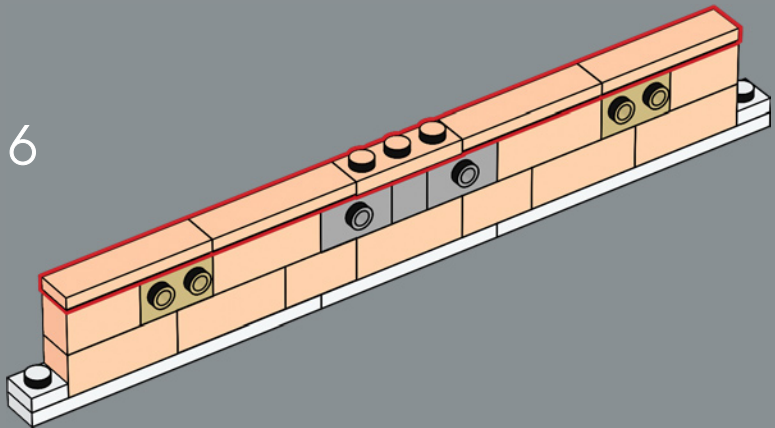



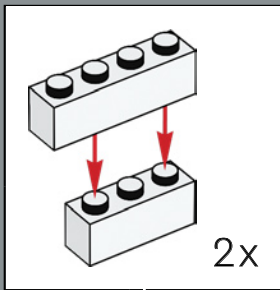
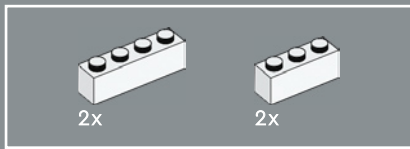

295

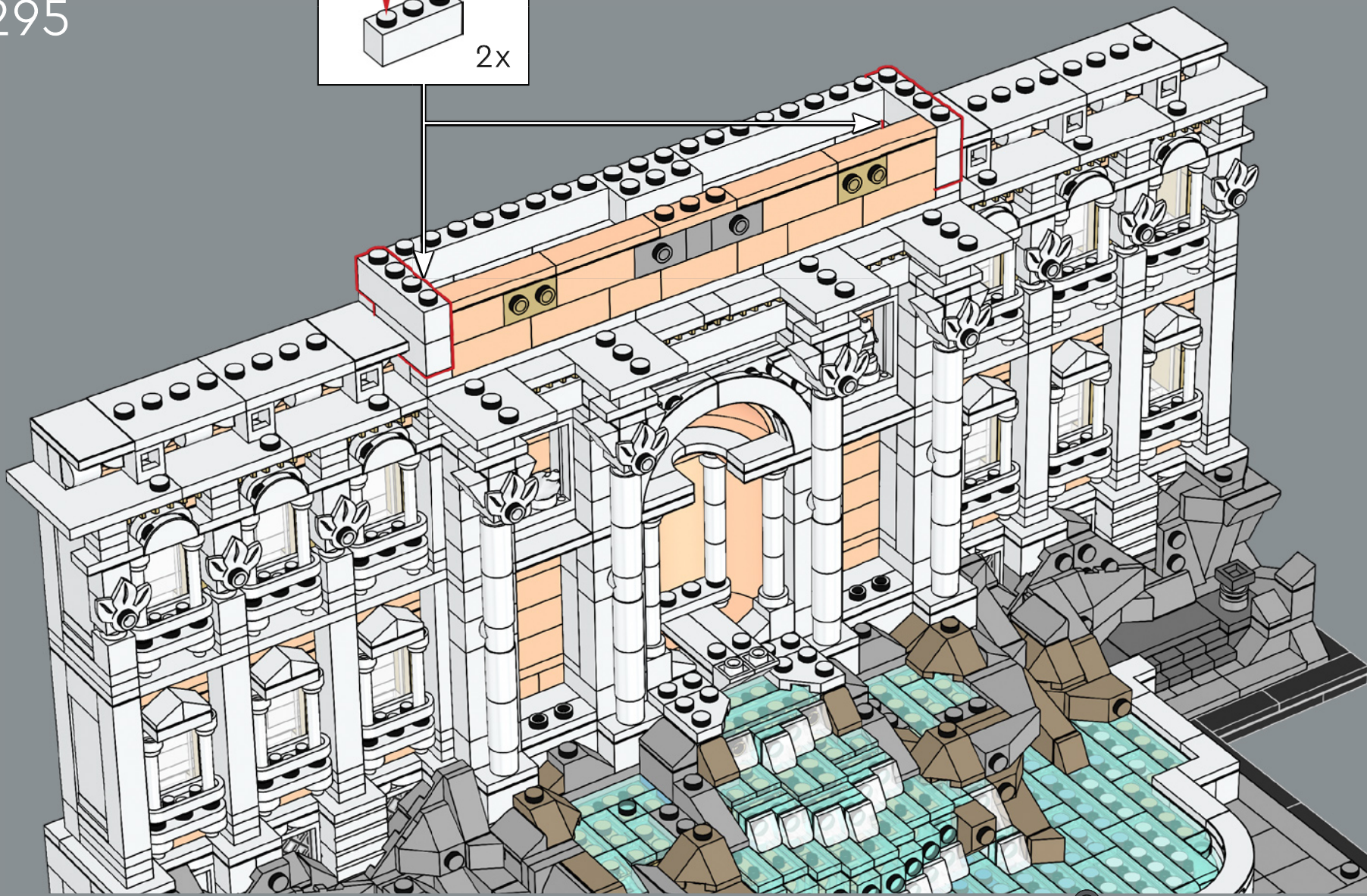

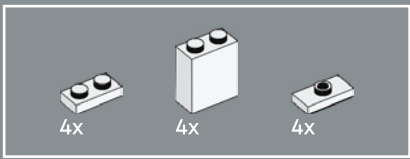

296

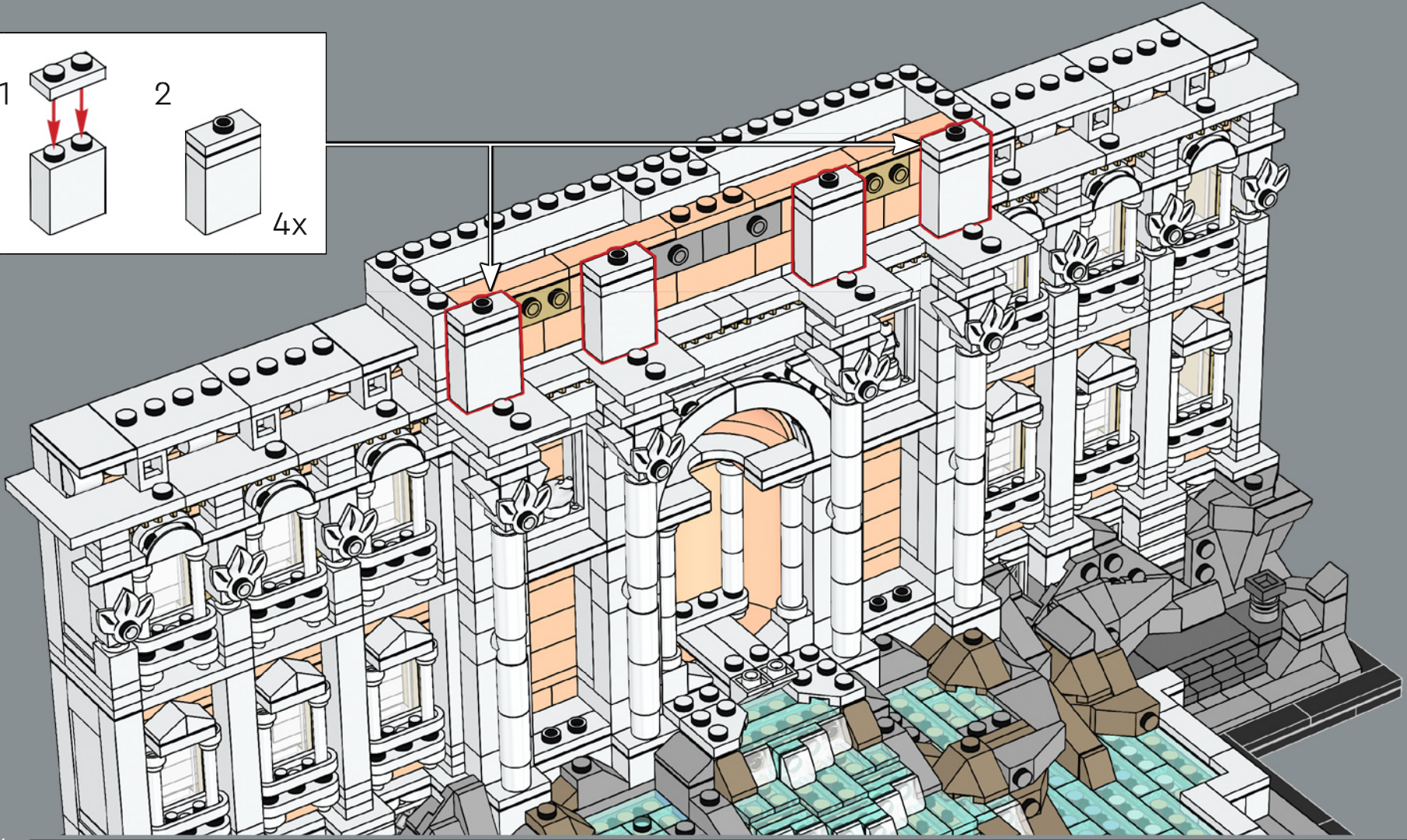
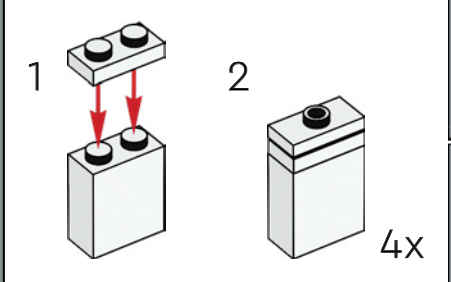

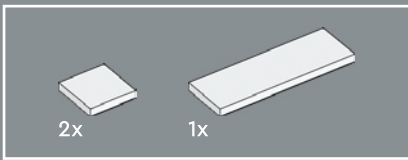

297

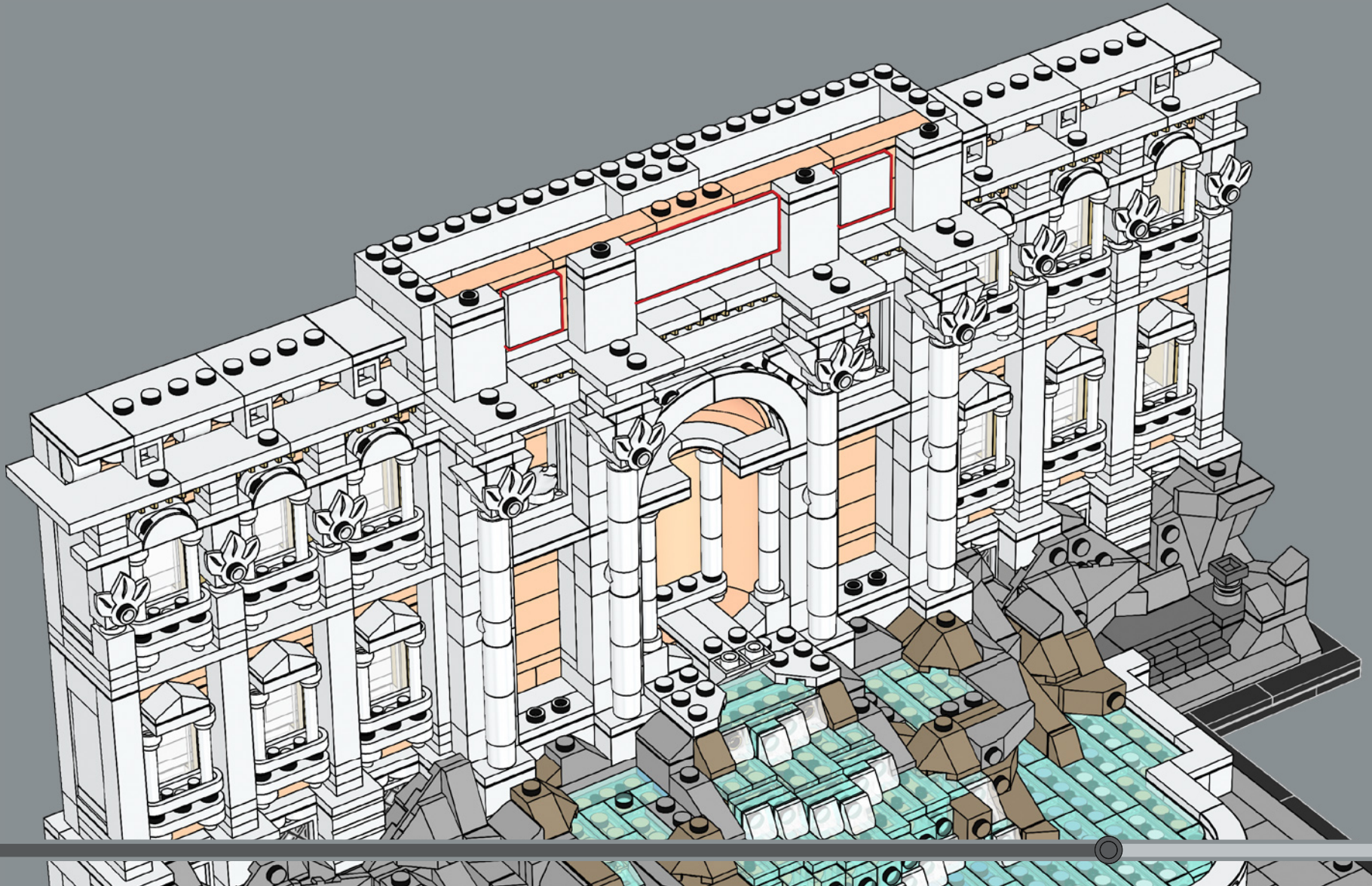

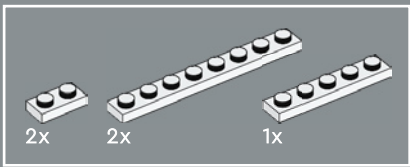

298

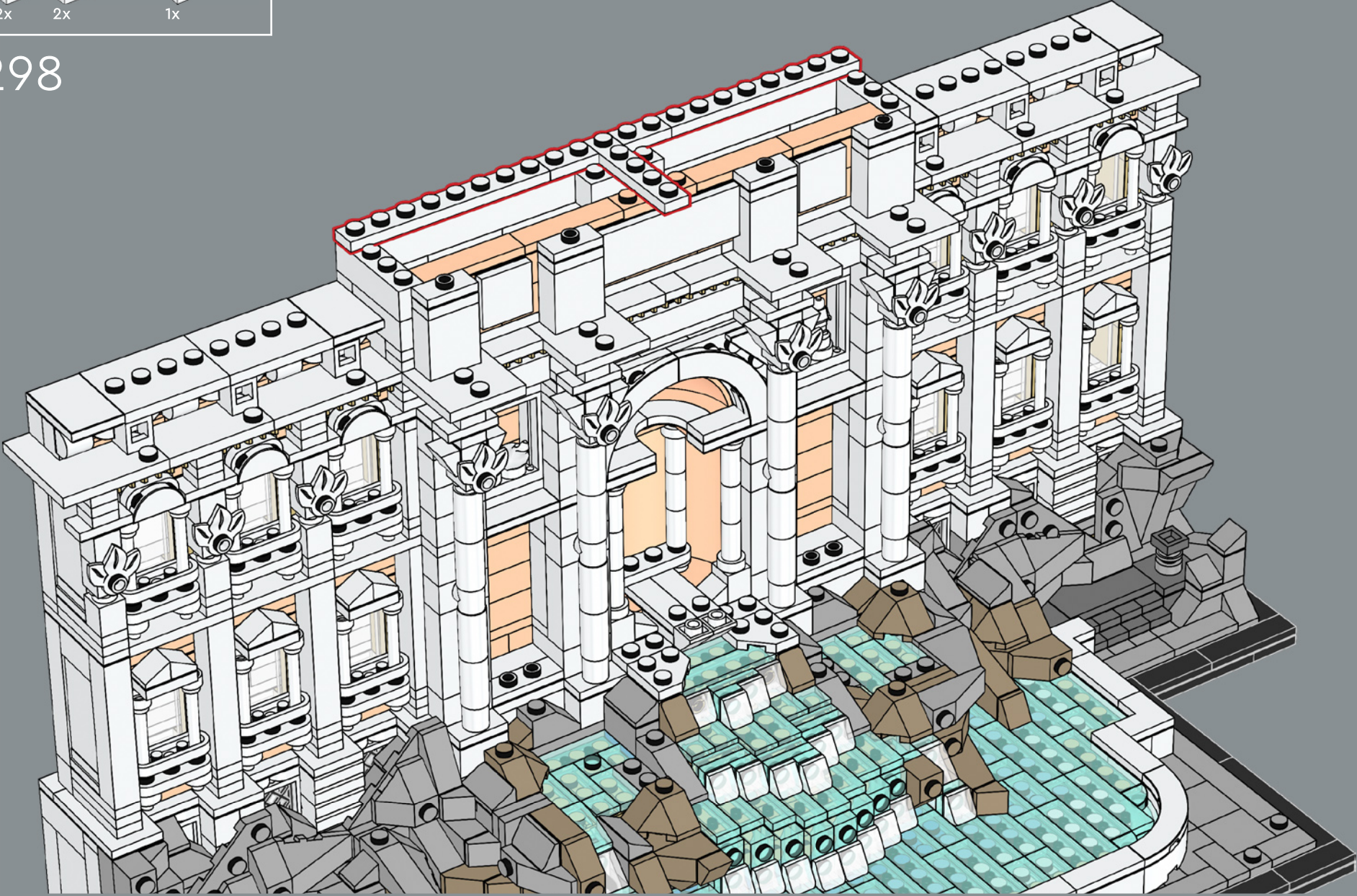

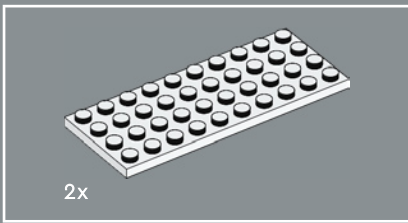

299

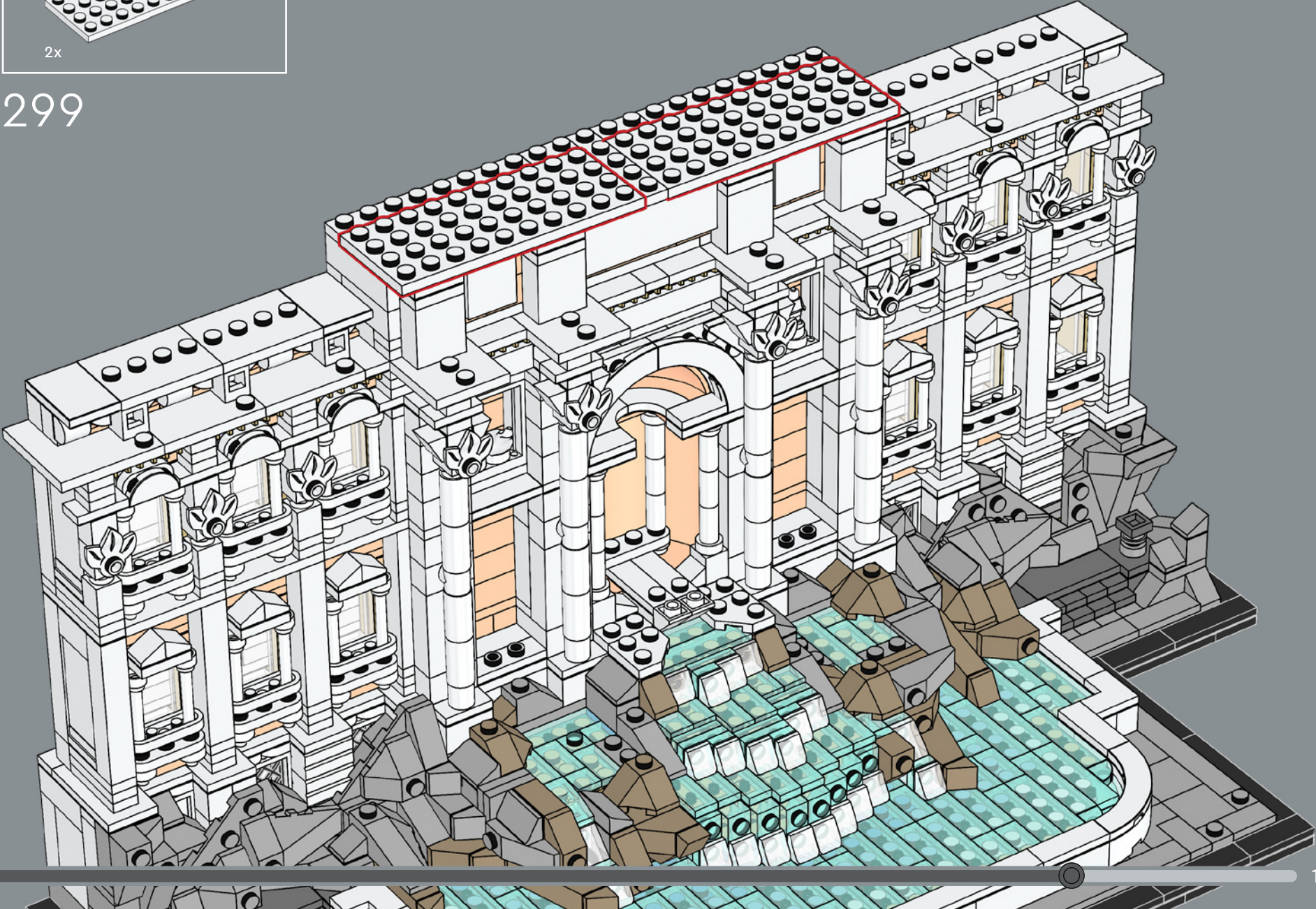

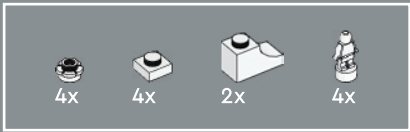

Estas estatuas representan las cuatro estaciones:  
*La abundancia de frutos, La fertilidad de los campos,  
Los frutos del otoño y La belleza de las praderas.*

300

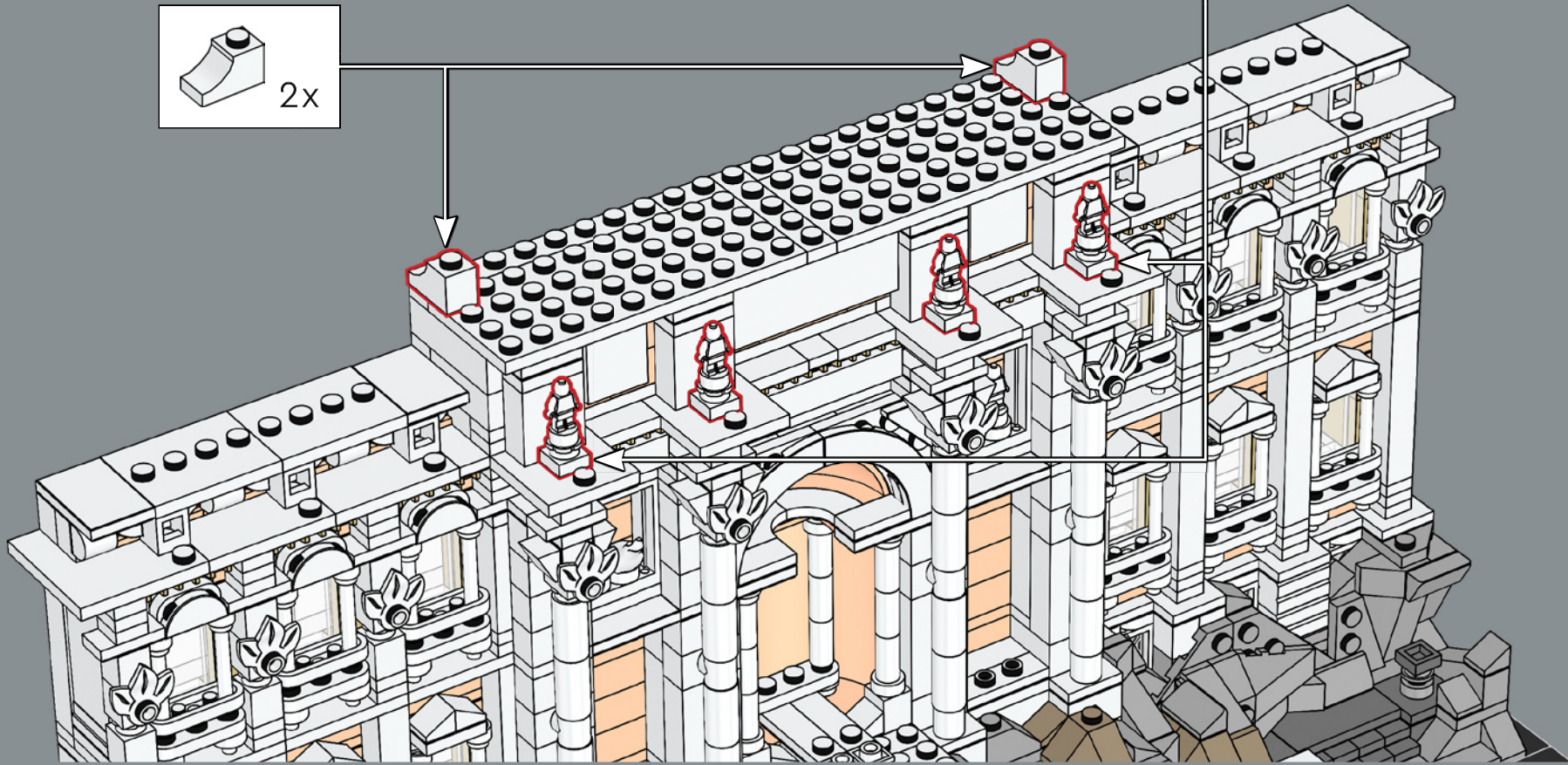
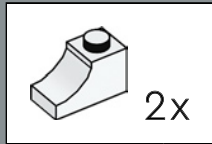
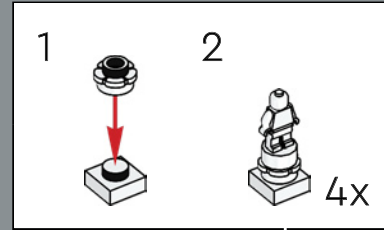

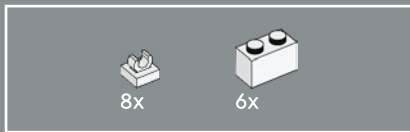

301

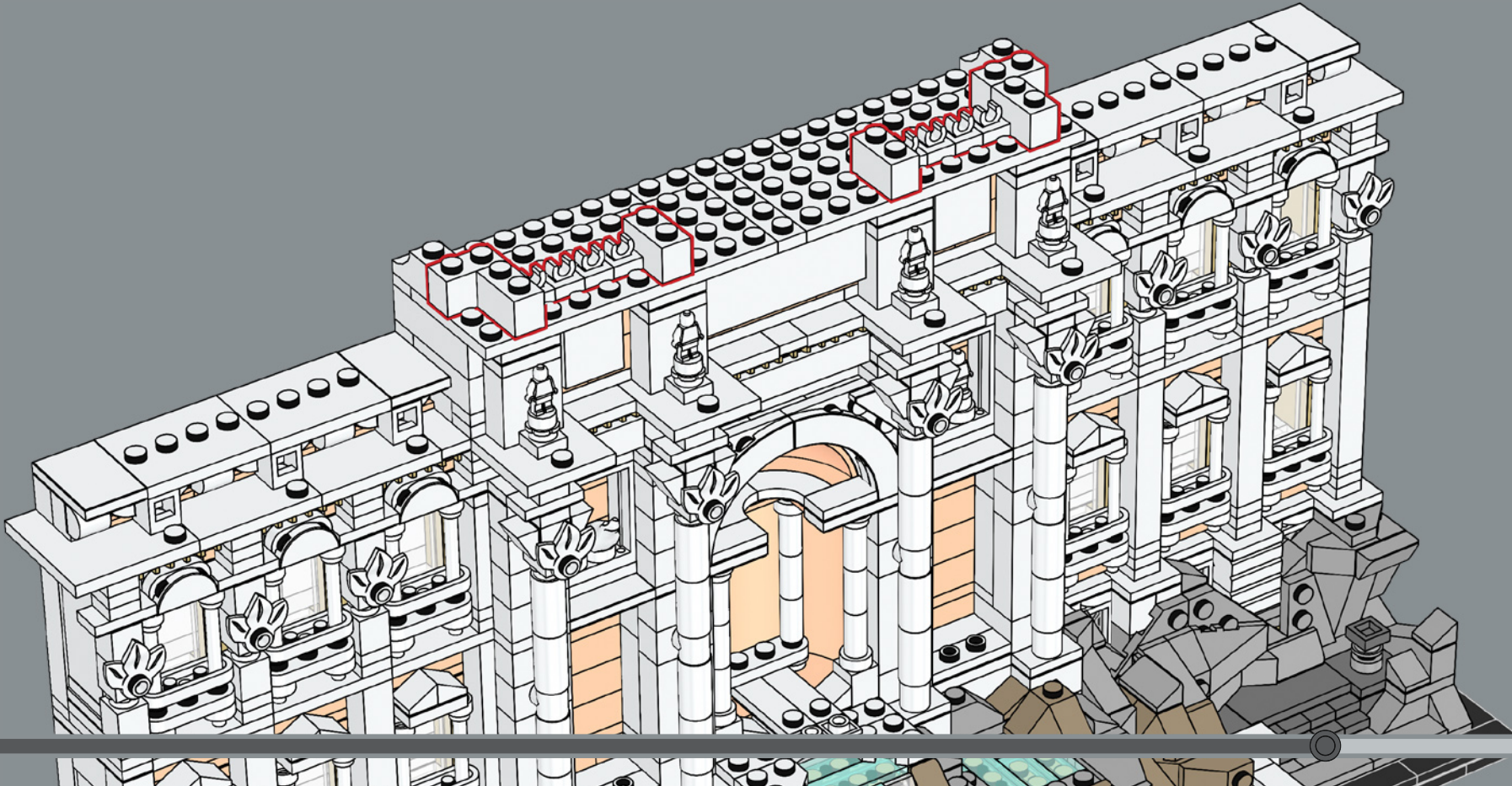

2x 1x 2x

302

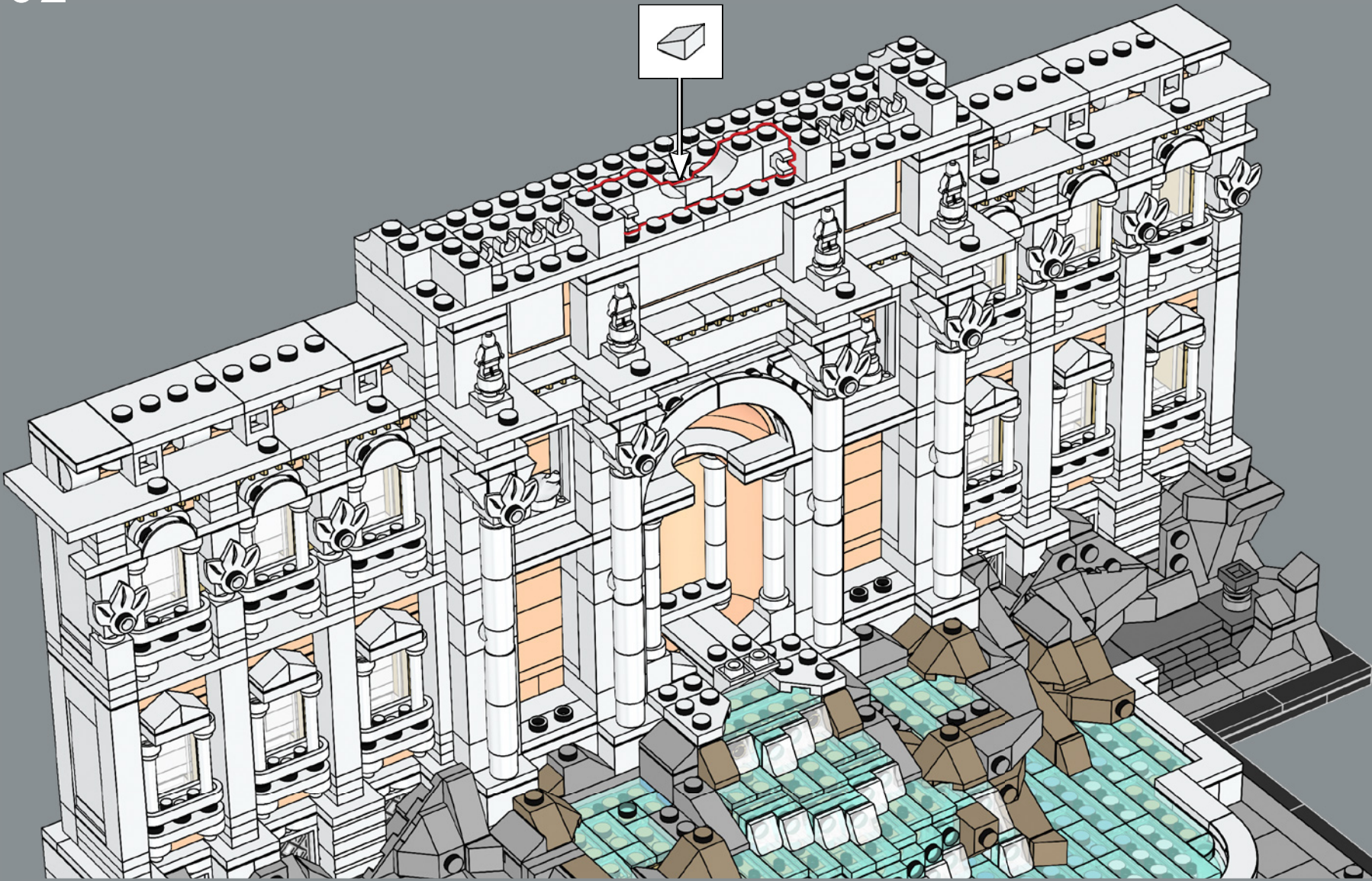
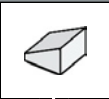



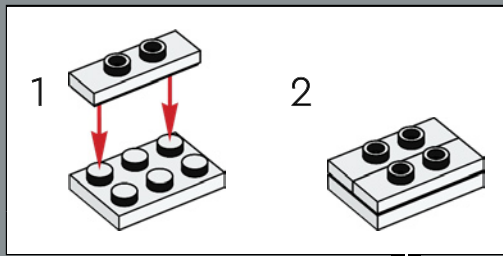
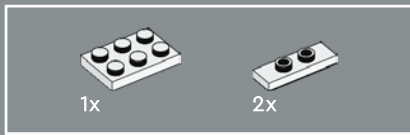

303

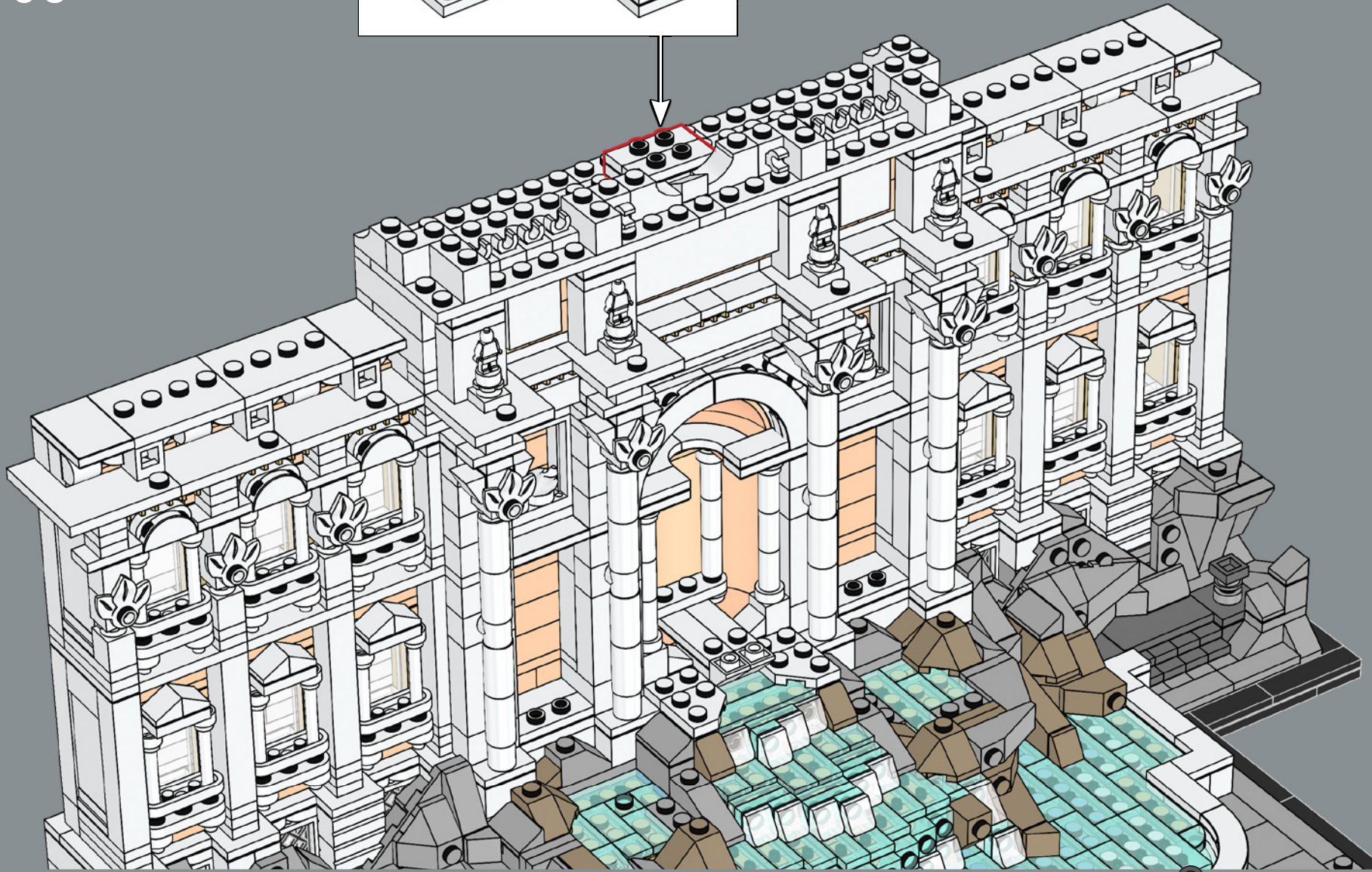

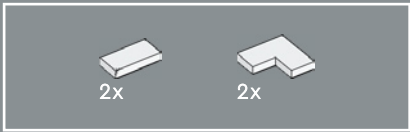

304

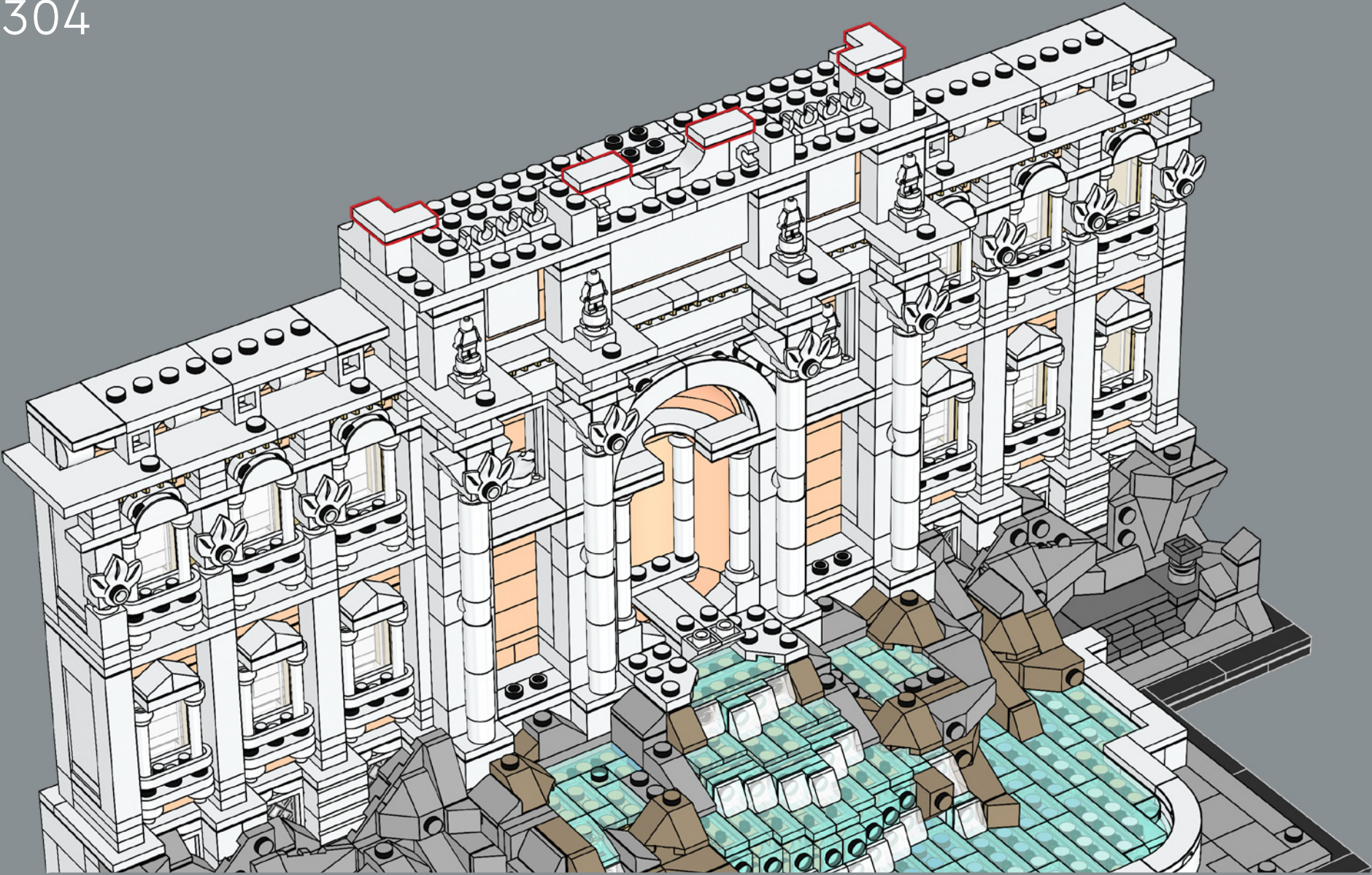

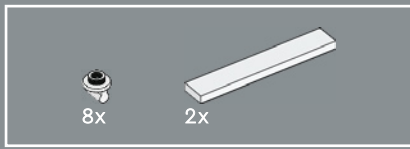

305

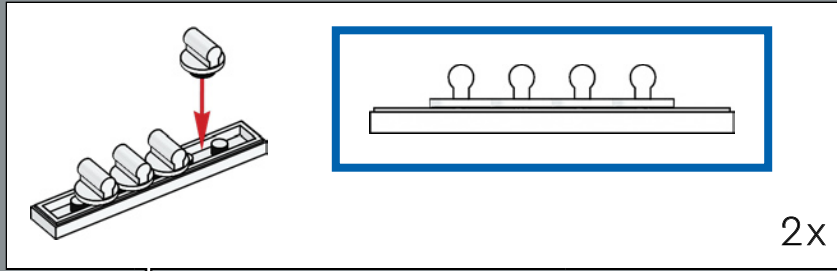

Las columnas ornamentales de la balaustrada más alta son el resultado de la combinación de clips y barras LEGO®.

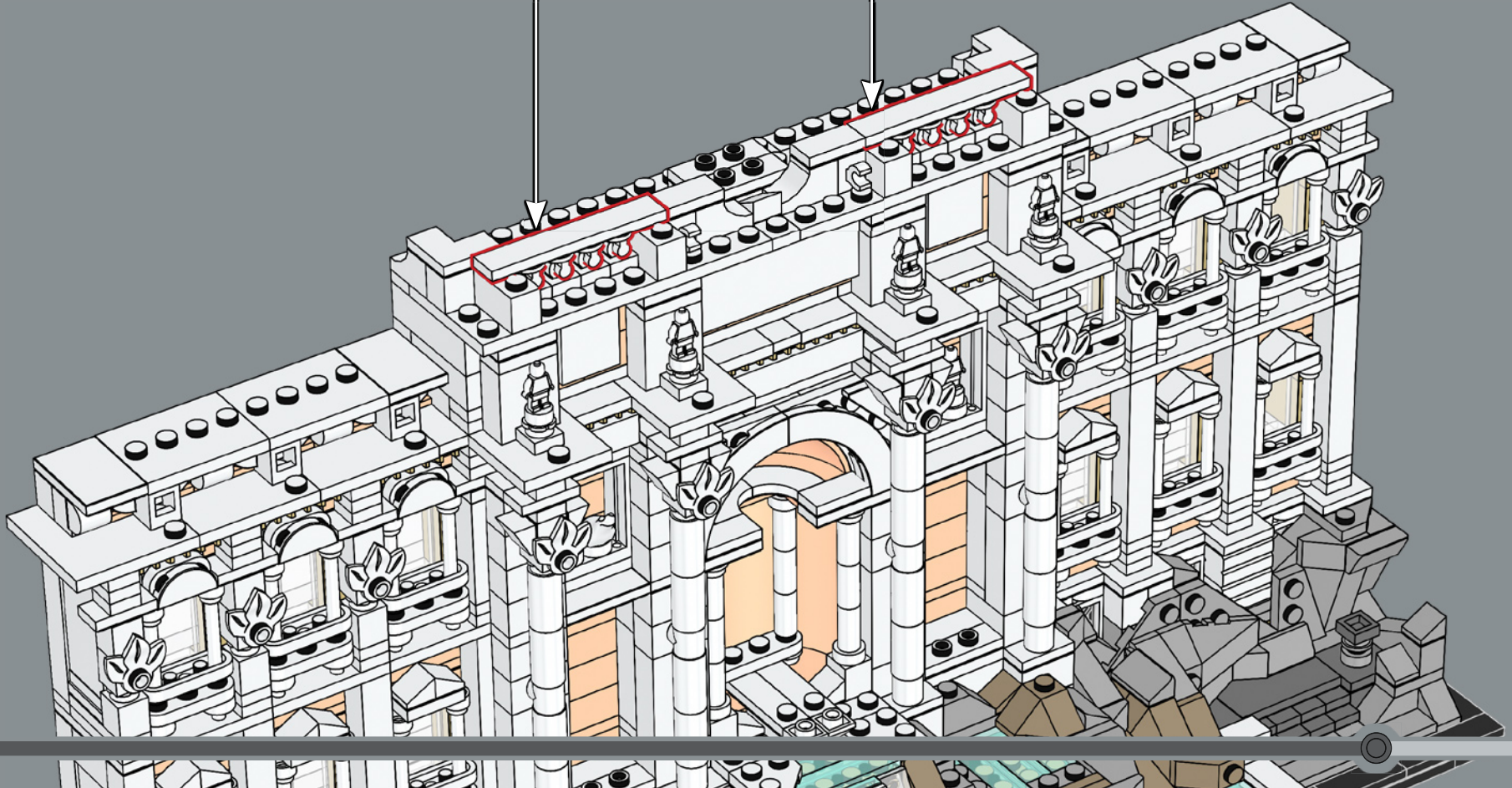

4x  2x 

306

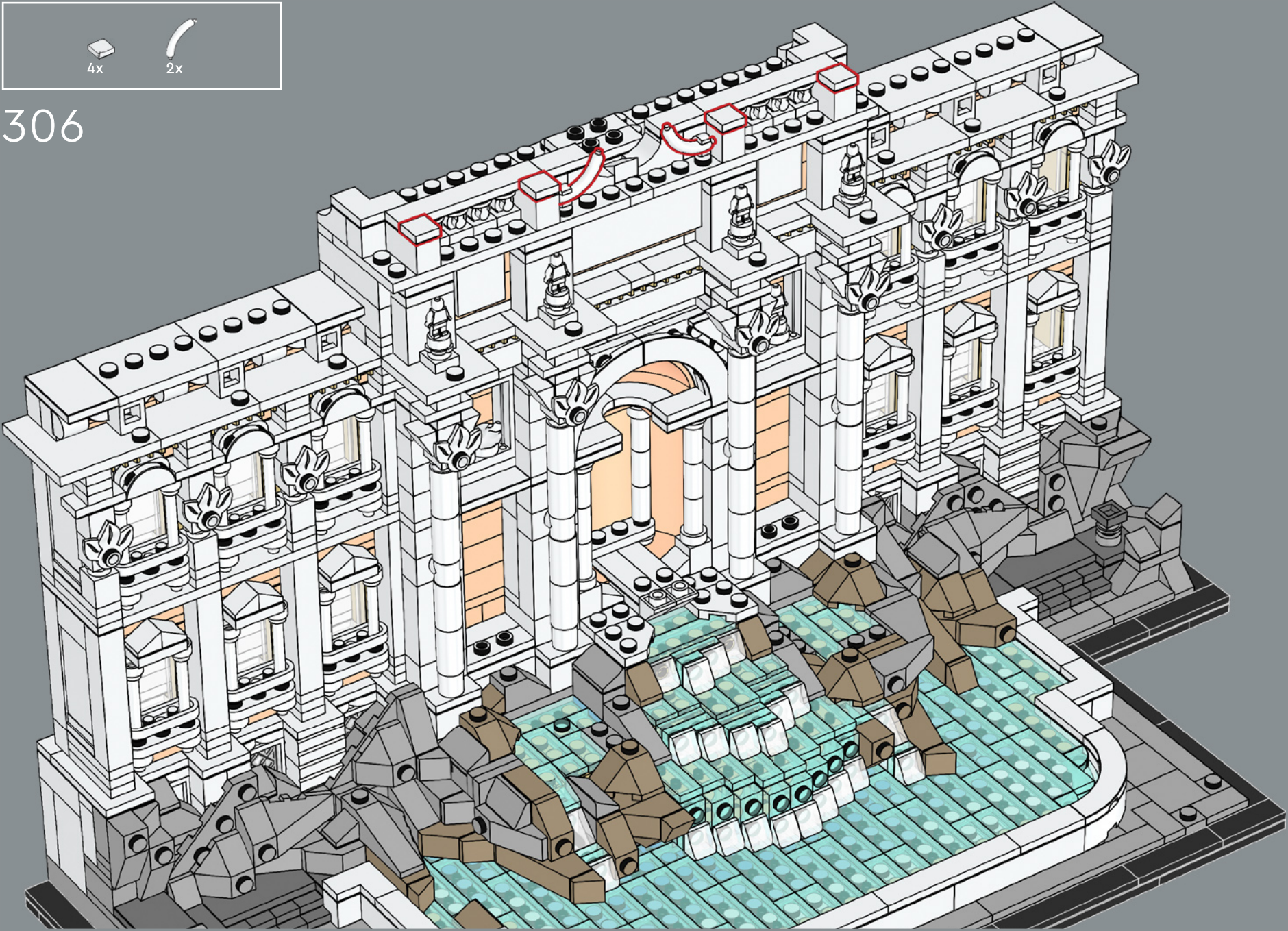

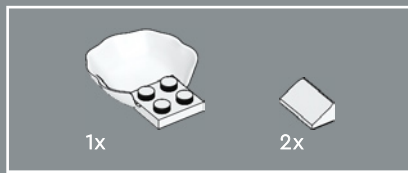

307



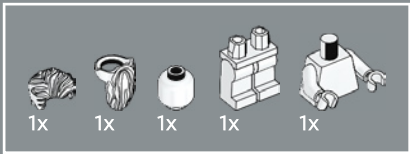

308

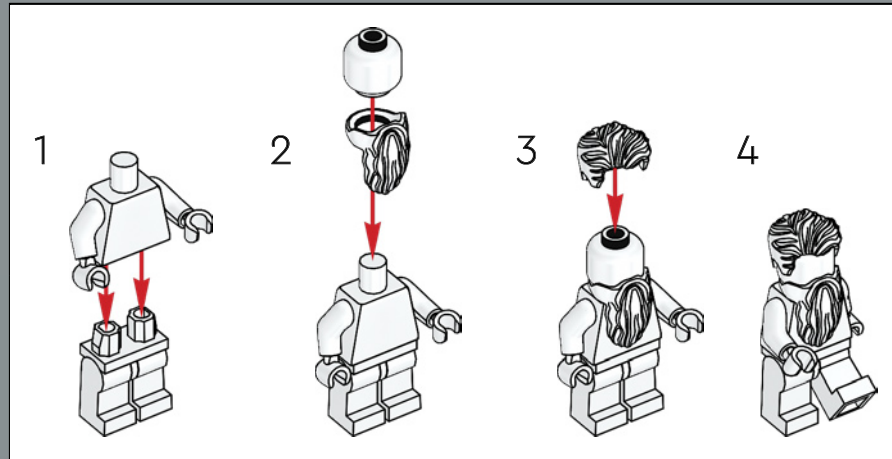

Esta es la primera vez que aparece una minifigura en un set LEGO® Architecture.

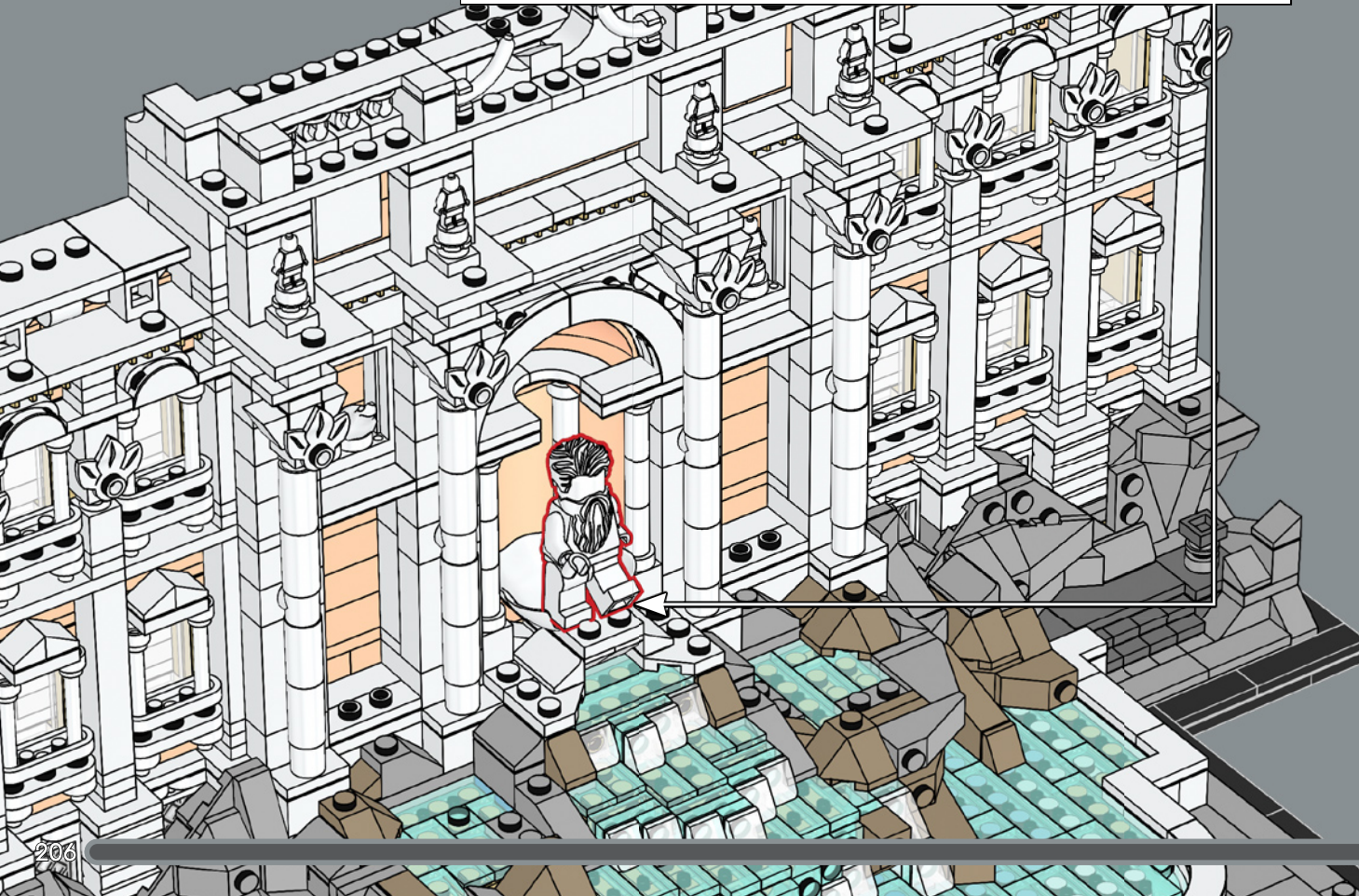

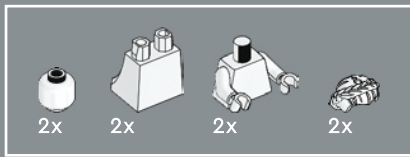

309

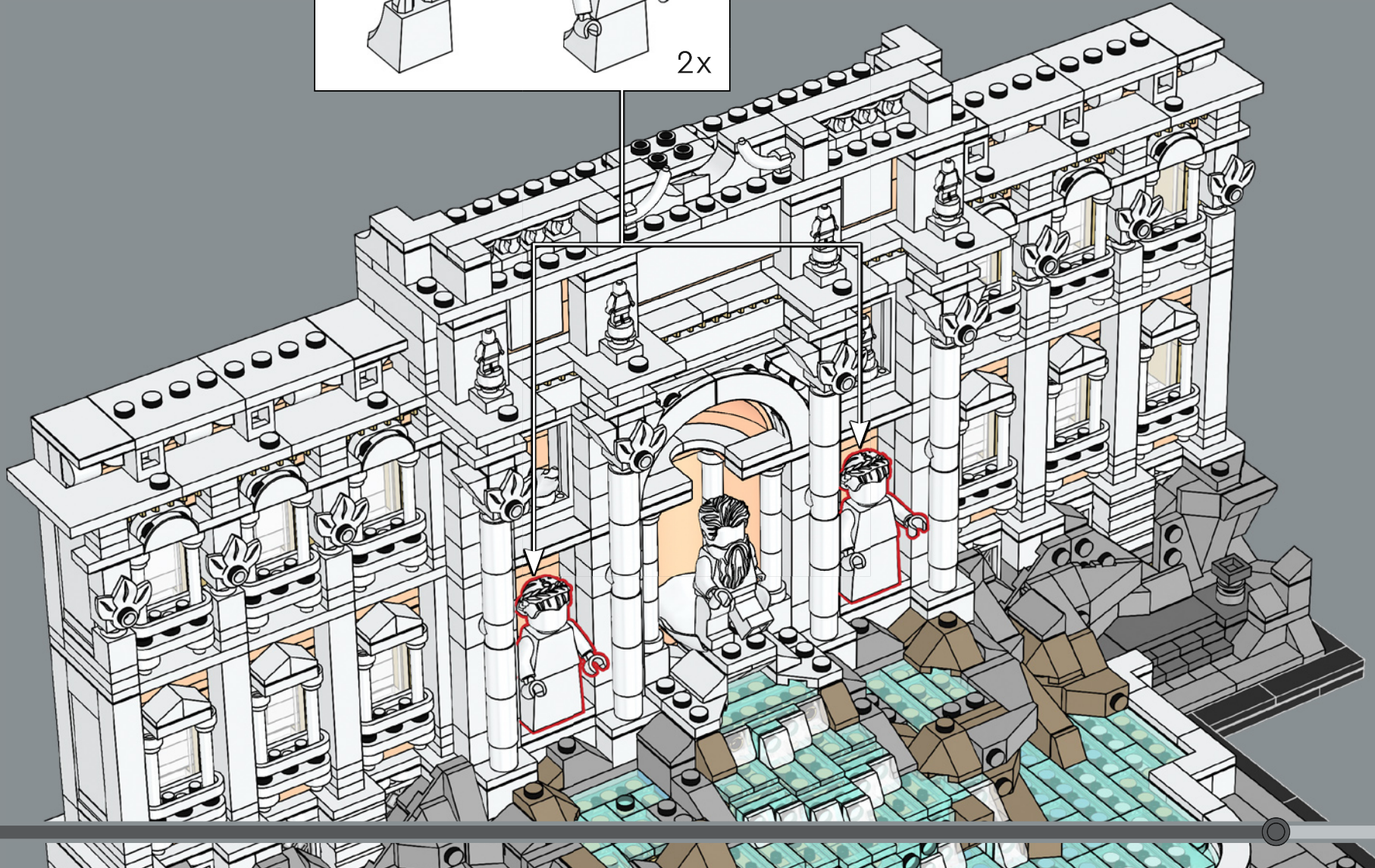
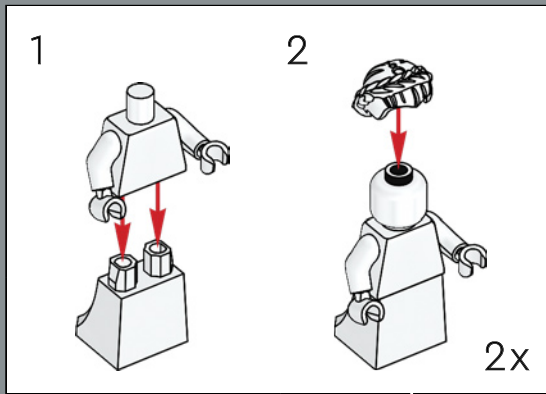

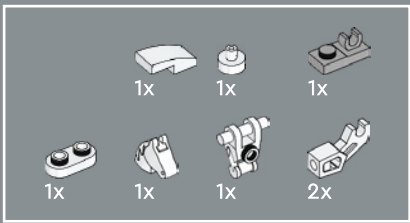

# 310

La cabeza de caballo LEGO® proviene de una edición LEGO Minifigures coleccionable y vuelve a cobrar vida en los *hippocampi*, o caballitos de mar míticos.

1



2

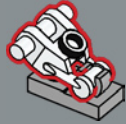

3

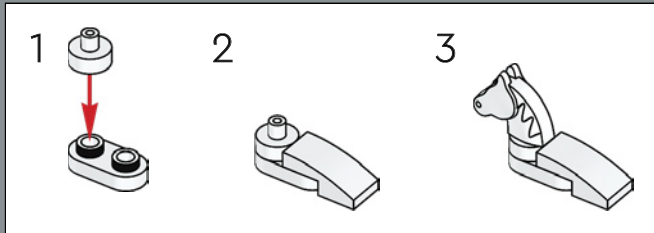
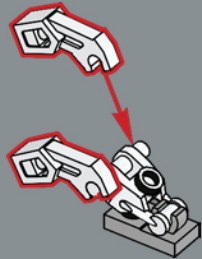

4

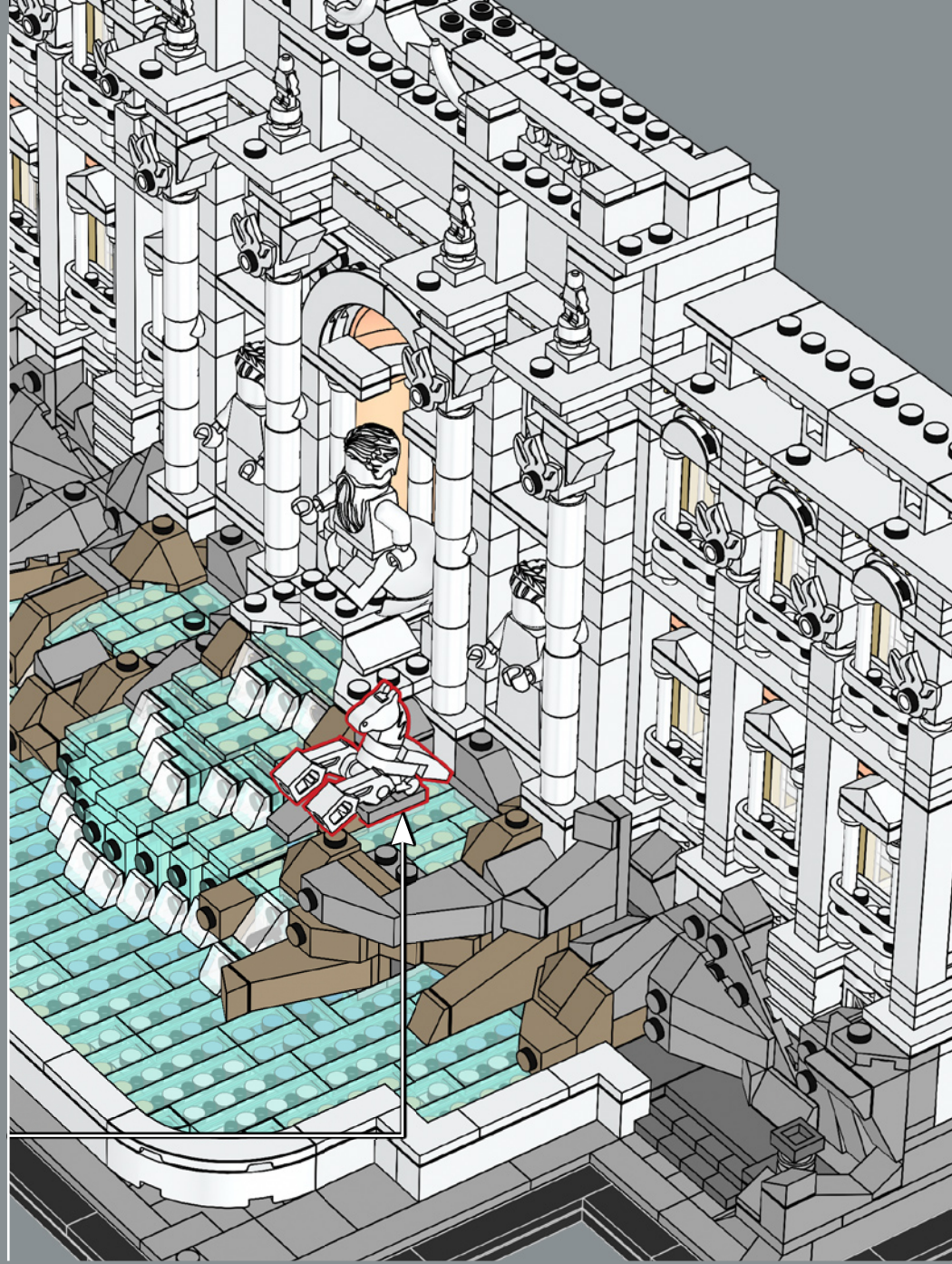
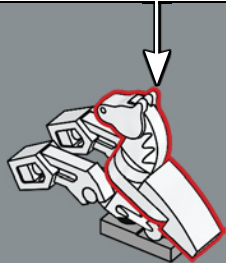





311

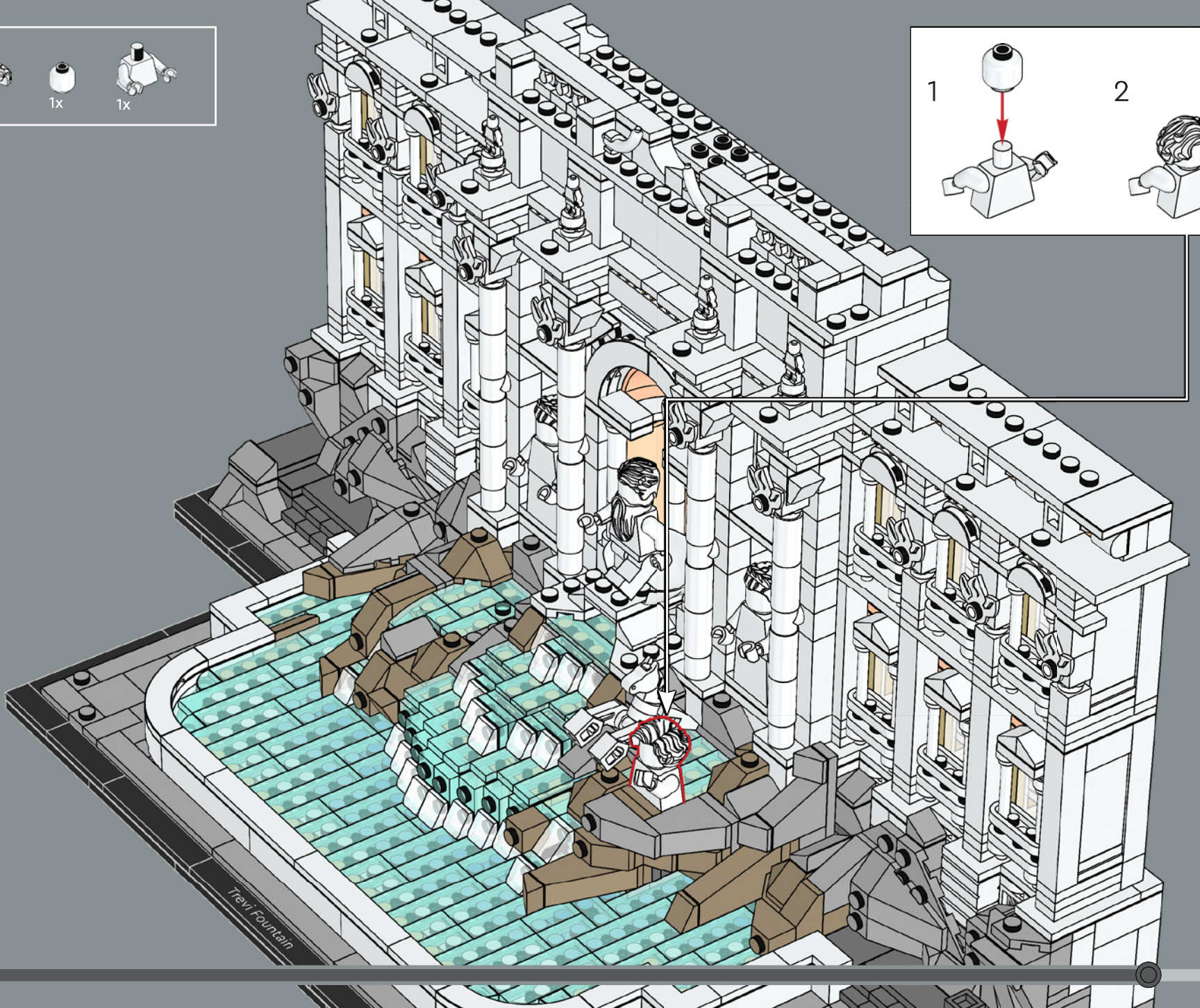
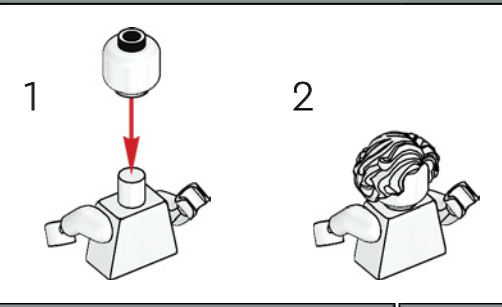

Trevi Fountain



312

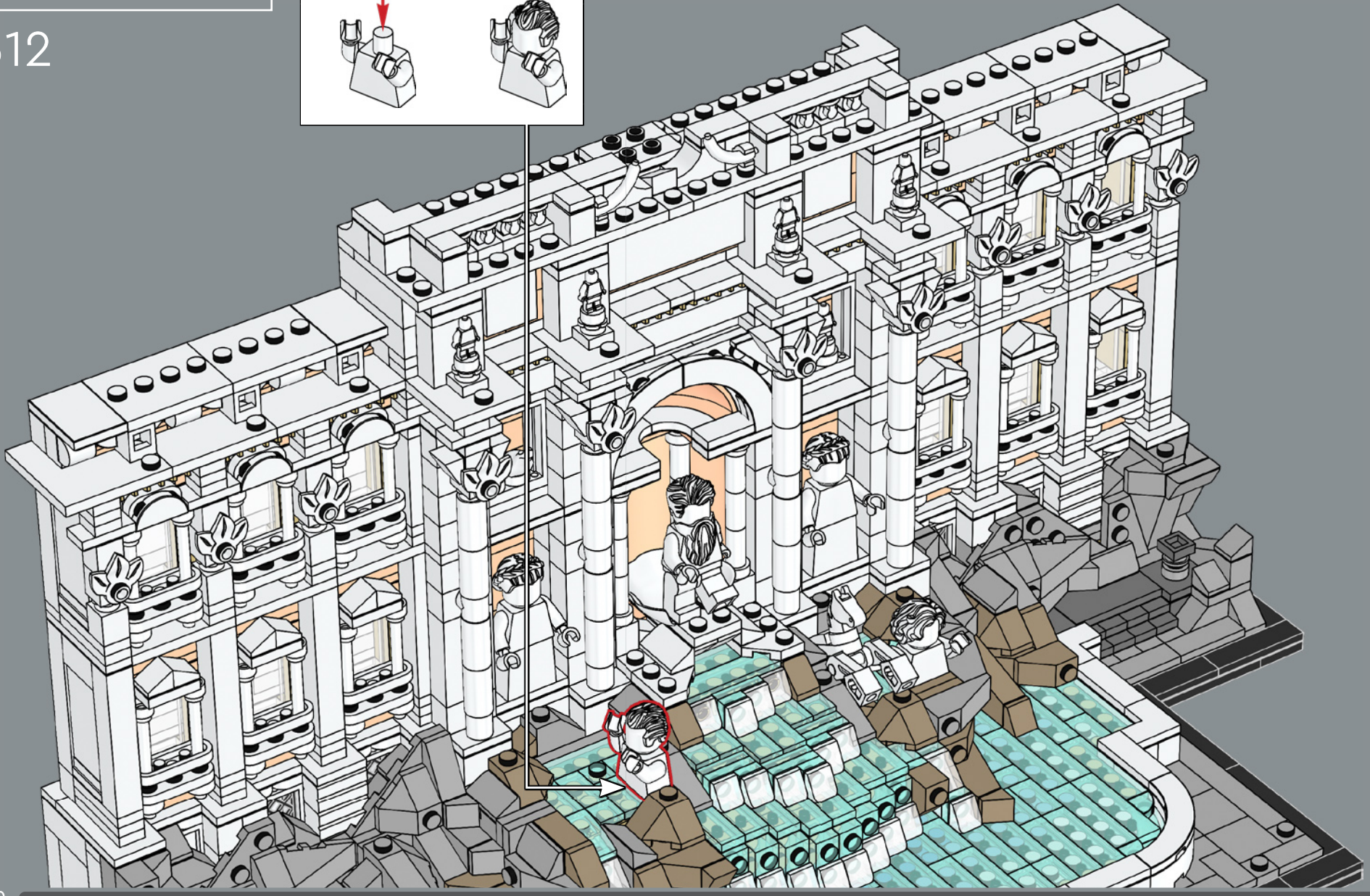
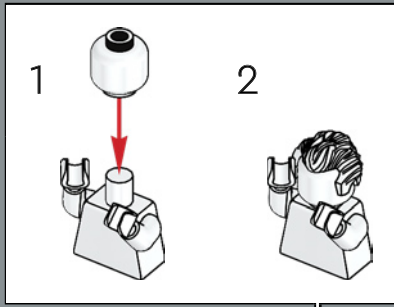

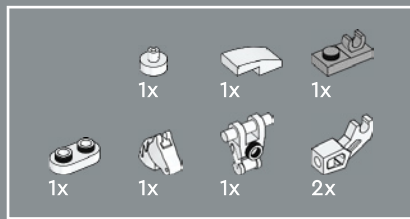

313

1



2

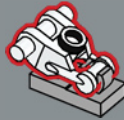

3

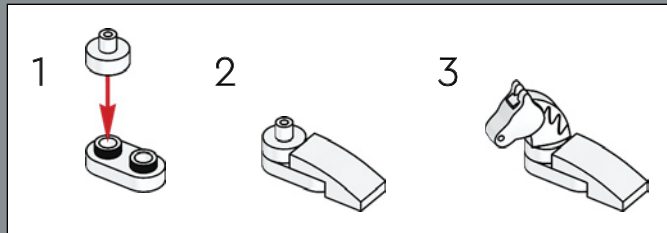
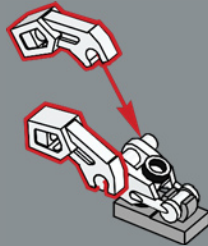

4

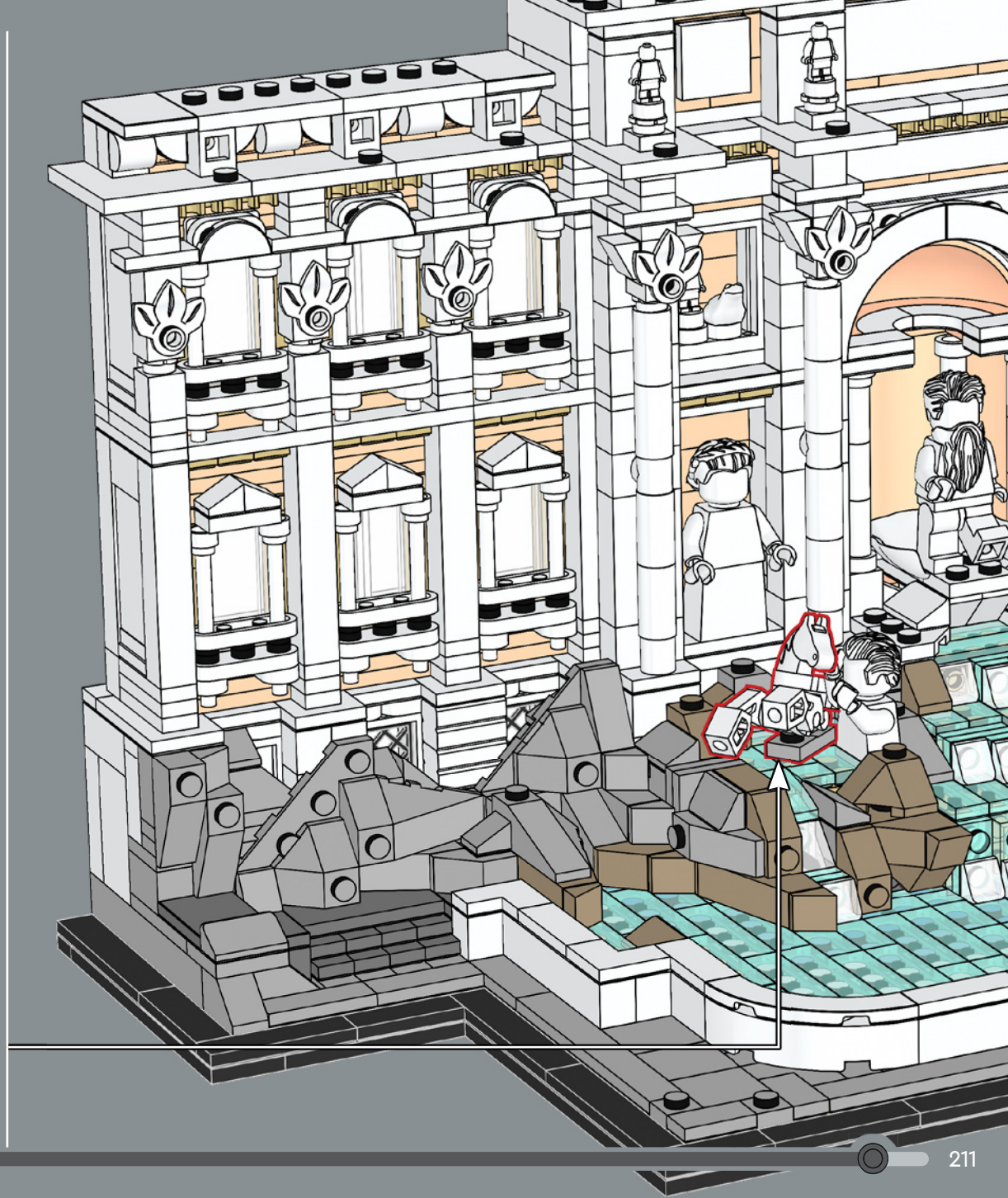
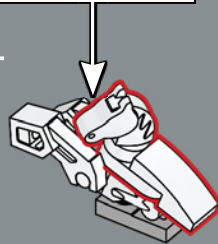

2x 2x

314

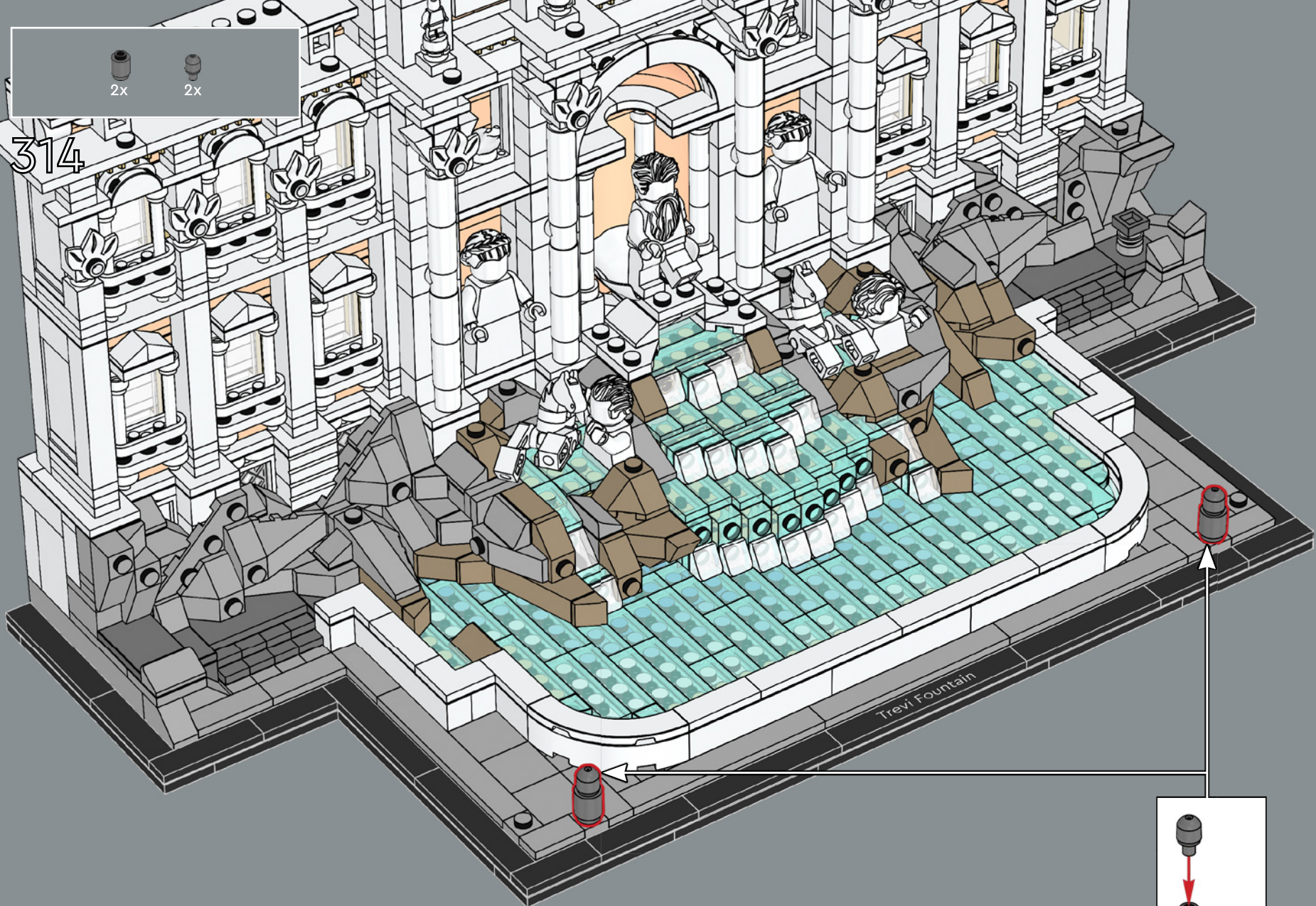

Trevi Fountain

2x

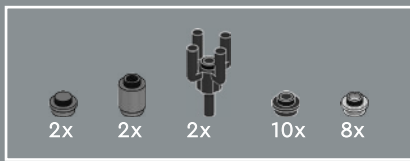

315

1

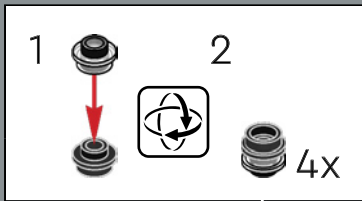
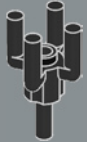

2

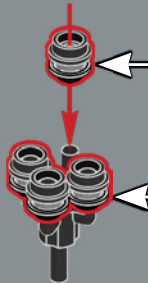

3

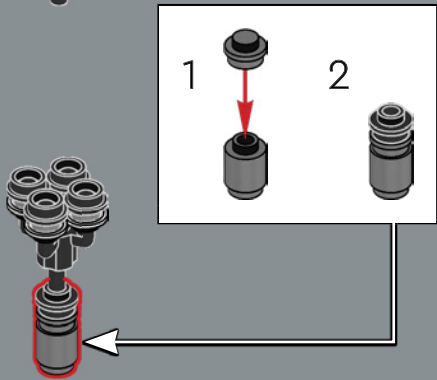

2x

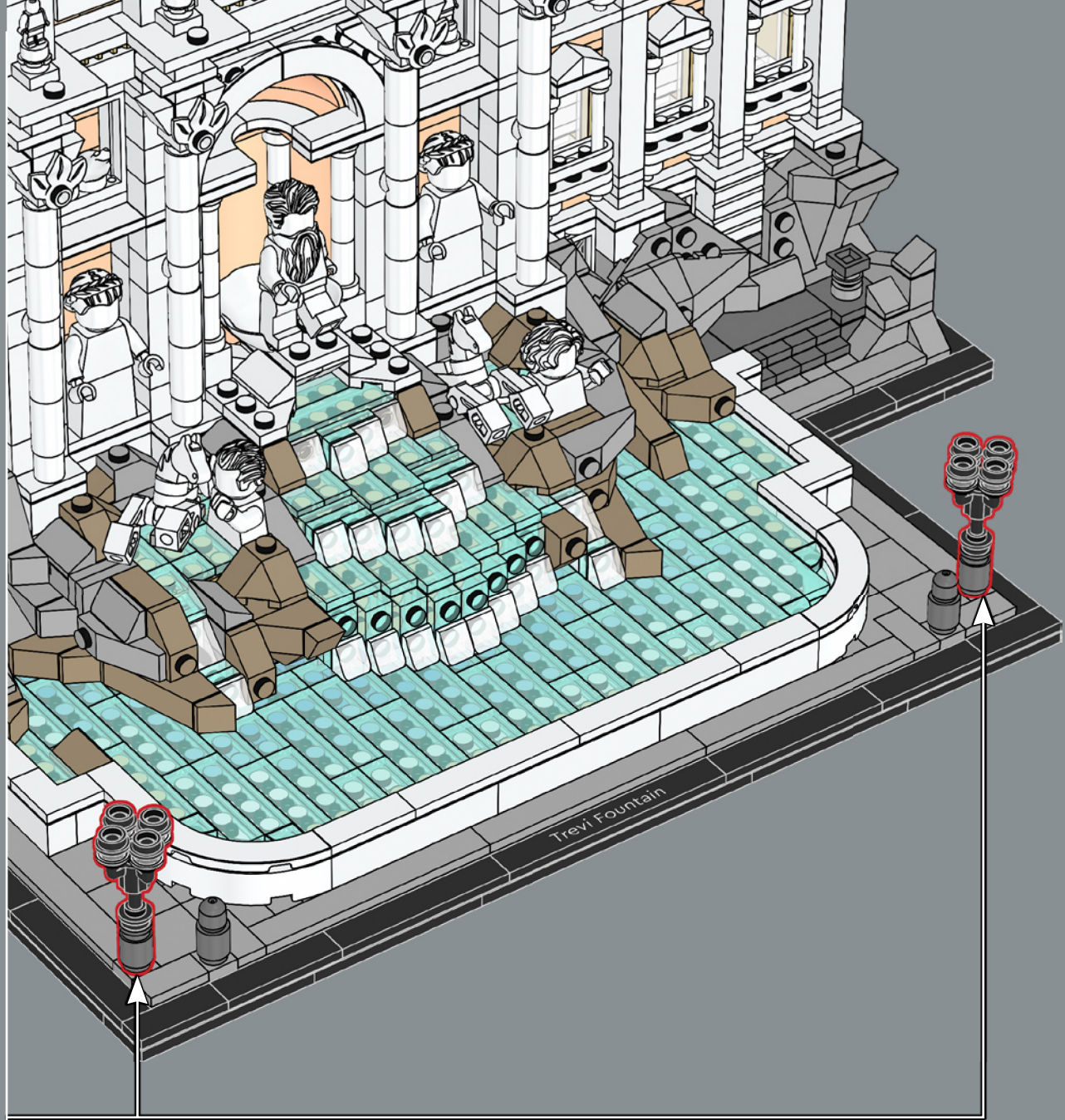

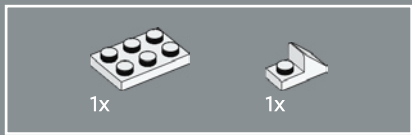

316

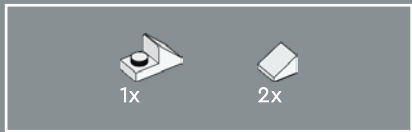
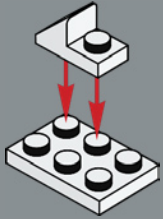

317

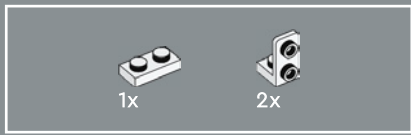
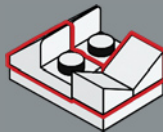

318

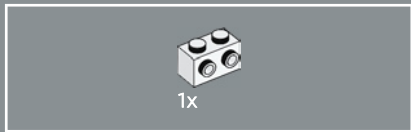
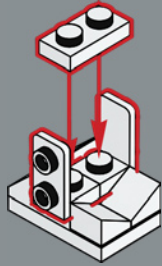

319

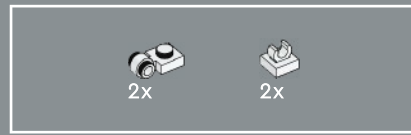
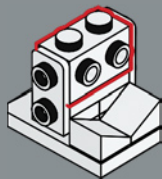

320

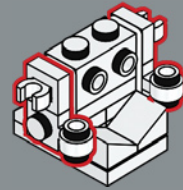

321

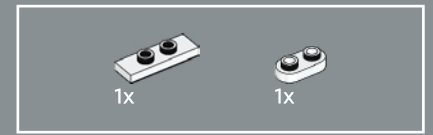
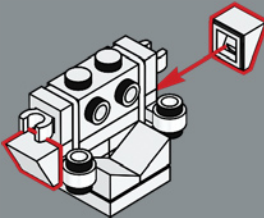

322

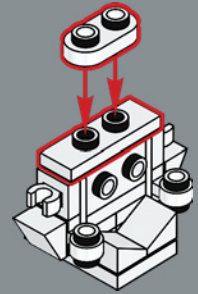

323

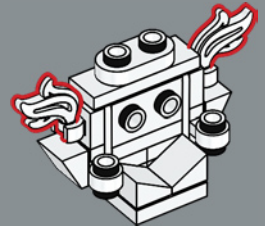



2x

324

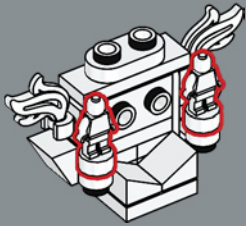

1x

325

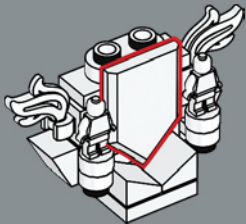

2x

326

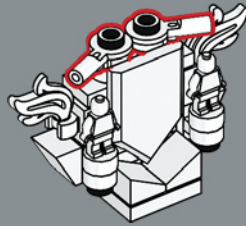

1x



1x

327

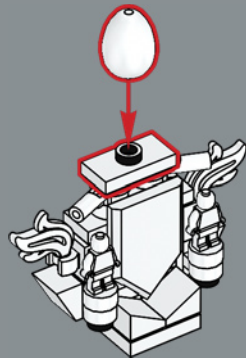

328

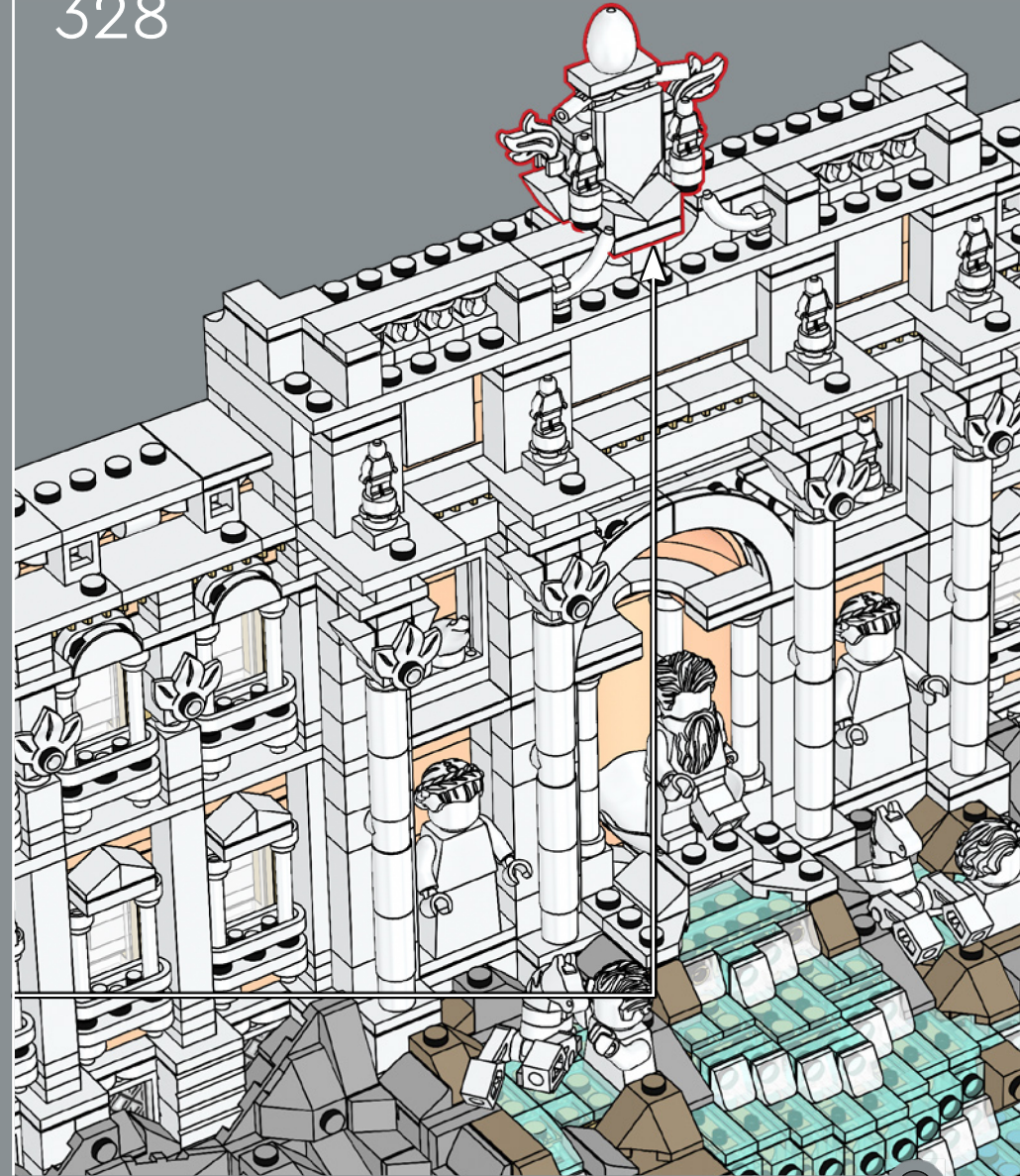

La Fontana di Trevi, tallada en travertino, ha servido como telón de fondo a un gran número de películas clásicas, como *La dolce vita*, de Federico Fellini (1960).

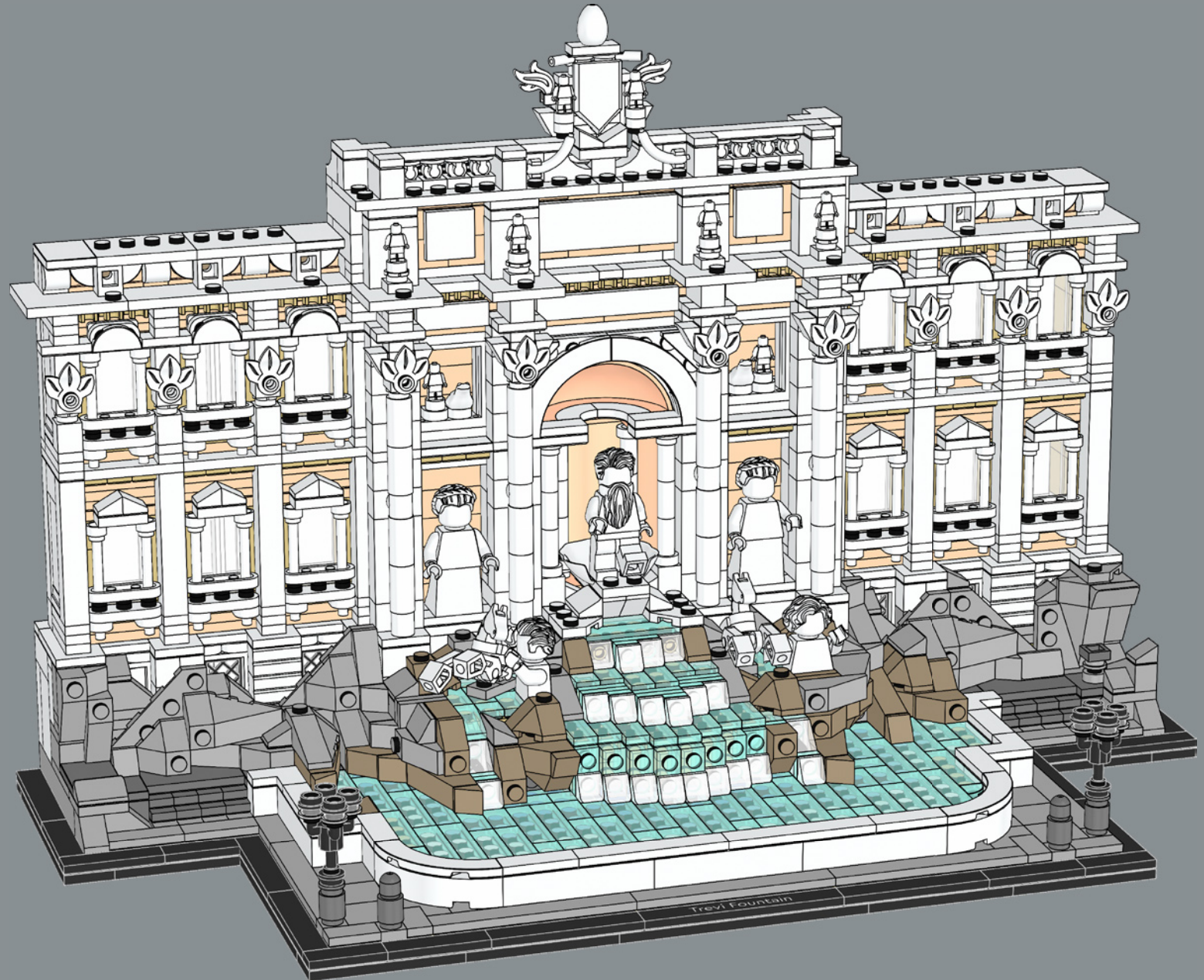



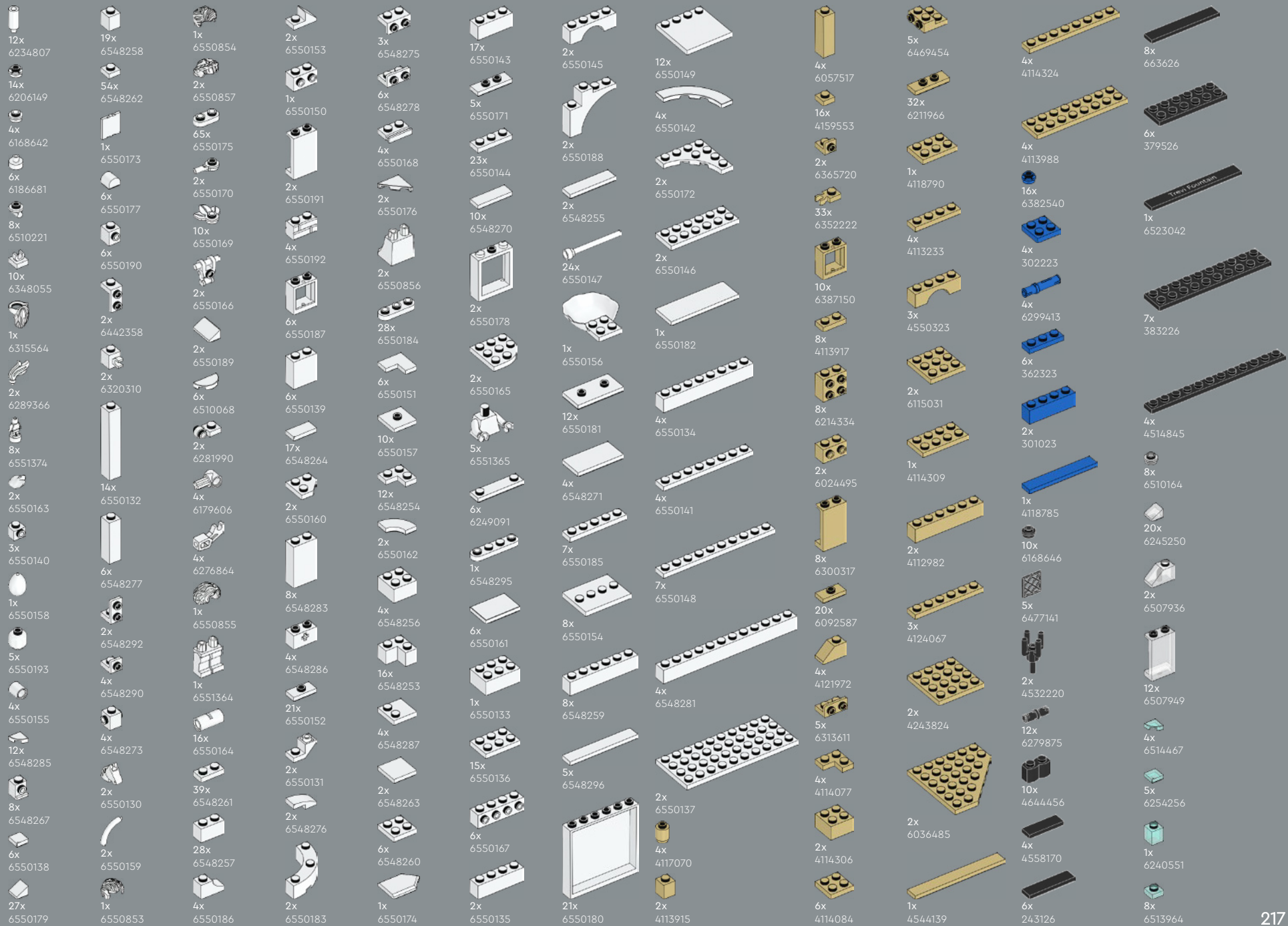

- 2x 6537848
- 14x 6514007
- 39x 6514224
- 6x 6514268
- 1x 6508249
- 54x 6510178
- 1x 6240515
- 10x 6322841
- 4x 6001824
- 9x 4530678
- 5x 4528604
- 4x 4653509
- 1x 6449563
- 1x 4521914
- 2x 6093064
- 1x 6228921
- 7x 6331865
- 2x 6035540
- 10x 6040126
- 1x 6015449
- 1x 6168647
- 1x 6258831
- 3x 4211389
- 19x 4521921
- 3x 6225242
- 6x 4211399
- 8x 4211415
- 4x 4558953
- 6x 6248890
- 1x 4211791
- 10x 4568637
- 1x 6213378
- 1x 6186657
- 3x 6123809
- 4x 4515374
- 11x 4211614
- 4x 6066097
- 9x 4211414
- 4x 4211388
- 1x 6093859
- 1x 4211564
- 5x 4211398
- 2x 6326078
- 2x 6383177
- 1x 6217876
- 1x 4211349
- 2x 6177078
- 6x 4211413
- 2x 6034676
- 8x 6212077
- 11x 4211353
- 2x 6469440
- 11x 4211488
- 6x 4558169
- 8x 6211969
- 4x 4211396
- 4x 4160560
- 7x 4211445
- 1x 4180418
- 3x 4180408
- 1x 6372029
- 1x 4211438
- 6x 4211452
- 2x 4211795
- 7x 4211425
- 2x 4211392
- 5x 4211481
- 1x 6313653
- 5x 4211404
- 1x 4210719
- 16x 6092572
- 4x 4210978
- 1x 6126083
- 2x 6309059
- 2x 4211133
- 1x 4211104
- 2x 6343852
- 8x 6187008
- 2x 4211105
- 4x 4211001
- 2x 4560184
- 3x 4620760
- 2x 4211002
- 2x 4211498
- 2x 4251149
- 5x 4617862
- 4x 4211408
- 2x 4211360
- 2x 4662161
- 1x 6528242
- 2x 6344216
- 4x 4211090
- 2x 4210633
- 4x 6395635
- 1x 6228923
- 4x 4558955
- 2x 4211107
- 2x 4211061
- 2x 4210678
- 4x 6000970
- 16x 6426347
- 4x 6357797
- 6x 6369189
- 16x 6329282
- 4x 6369188
- 21x 6357794
- 10x 6501239
- 4x 6440965
- 12x 6424071
- 1x 6541427
- 1x 6537849
- 12x 6537846
- 2x 6329604
- 4x 6439745
- 8x 6206809
- 4x 6144149
- 4x 4649741
- 2x 6070757
- 8x 4655256
- 2x 6146701
- 6x 6141592
- 2x 6138662



 [LEGO.com/service](https://www.LEGO.com/service)



# YOU COULD WIN



## YOU COULD WIN

Your feedback will help shape the future development of this product series.

Visit:

## DU KÖNNTEST GEWINNEN

Dein Feedback trägt zur Weiterentwicklung dieser Produktreihe bei.

Geh auf:

## VOUS POURRIEZ GAGNER

Vos commentaires nous aideront à concevoir les futurs produits de cette gamme.

Visitez :

## POTRESTI VINCERE TU

La tua opinione ci aiuterà a migliorare la creazione futura di questa linea di prodotti.

Visita:

## PUEDES GANAR

Tu opinión contribuirá al futuro de esta serie de productos.

Visita:

## 轻松获奖

您的反馈将有助于我们在今后改进本产品系列。

请访问:

---

**[LEGO.com/productfeedback](https://www.lego.com/productfeedback)**

---

You also have the chance to win a LEGO® set.

Terms and conditions apply.\*

Außerdem hast du die Chance, ein LEGO® Set zu gewinnen.

Es gelten die Teilnahmebedingungen.\*

Vous pourriez également gagner un ensemble LEGO®.

Des conditions s'appliquent.\*

Hai anche la possibilità di vincere un set LEGO®.

Termini e condizioni sono applicabili.\*

También tienes la oportunidad de ganar un set LEGO®.

Aplican términos y condiciones.\*

您还有机会赢取乐高®套装。

条款和条件适用。\*

\*[LEGO.com/productfeedback-terms](https://www.lego.com/productfeedback-terms)

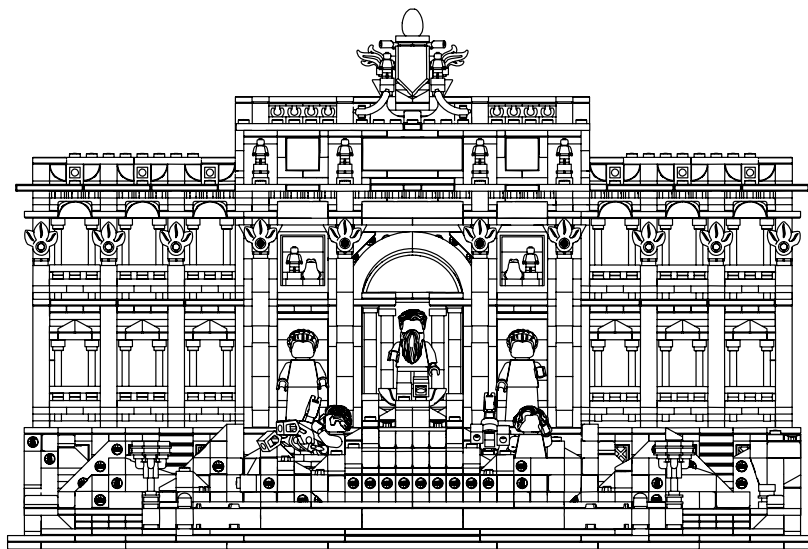

LEGO and the LEGO logo are trademarks of the LEGO Group. ©2025 The LEGO Group.  
Adam Reed Tucker is the co-developer of the LEGO® Architecture product line.