



# STAR WARS

75159

Booklet available in English on:  
Heft in deutscher Sprache erhältlich auf:  
Livret disponible en français sur:  
Folleto disponible en español en:  
Folheto disponível em português em:  
A füzet magyarul ezen a honlapon olvasható:  
如需中文版手册, 请访问 [LEGO.com/starwars](http://LEGO.com/starwars)



 [LEGO.com](http://LEGO.com)



EN IMPORTANT: Never modify the elements or use other projectiles than provided with this toy.  
 DE WICHTIG: Die Elemente dürfen nicht verändert werden. Es dürfen ausschließlich die mit dem Spielzeug mitgelieferten Geschosse verwendet werden.  
 FR IMPORTANT : Ne jamais modifier les éléments ni utiliser d'autres projectiles que ceux fournis avec ce jouet.  
 IT IMPORTANTE: non modificare gli elementi o utilizzare proiettili non forniti con questo prodotto.  
 NL BELANGRIJK: Verander niets aan de elementen en gebruik geen andere projectielen dan de bij het speelgoed geleverde.  
 ES IMPORTANTE: No modifique los elementos ni utilice otros proyectiles diferentes a los suministrados junto con este juguete.  
 DA VIGTIGT: Elementerne må ikke ændres, og der må ikke bruges andre projektiler end dem, der følger med legetøjet.  
 IS MIKLIVÆGT: Aldrei skal breyta einungum vörunnar eða nota önnur skot en þau sem fylgja þessu leikfangi.  
 FI TÄRKEÄÄ: Älä koskaan tee osiin muutoksia tai käytä lelussa muita kuin sen sisältyviä ammuksia.  
 SV VIKTIG: Modifiera aldrig delarna och använd aldrig andra projektiler än de som medföljer denna leksak.  
 NO VIKTIG: Elementene må ikke endres, og det må aldri brukes andre prosjektiler enn dem som følger med leketøyet.  
 PT IMPORTANTE: Nunca modifique os elementos nem utilize projécteis que não tenham sido fornecidos com este brinquedo.  
 EL ΣΗΜΑΝΤΙΚΟ: Ποτέ μην τροποποιείτε τα στοιχεία του παιχνιδιού και μην χρησιμοποιείτε άλλα βλήματα εκτός από αυτά που συνοδεύουν αυτό το παιχνίδι.  
 JA 重要: 部品を改造したり、本製品に付属の発射体以外のものを使用しないでください。  
 ZH 重要提示: 切勿更改组件或使用并非由本玩具附带的弹丸。  
 KO 중요: 이들 부품을 수정하거나 이 완구와 함께 제공된 것이 아닌 발사체는 결코 사용하지 마십시오.  
 RU ВАЖНО: Запрещается вносить изменения в элементы или использовать другие снаряды, отличные от тех, которые поставляются с данной игрушкой.  
 PL WAŻNE: Nigdy nie modyfikować elementów ani nie używać innych pocisków niż dostarczonych z zabawką.  
 CZ UPOZORNĚNÍ: Nikdy neupravujte součástky a nepoužívejte jiné projektily než ty, které jsou dodávány s touto hračkou.  
 SK UPOZORNENIE: Nikdy neupravujte súčiastky a nepoužívajte iné projektily než tie, ktoré sú dodávané s touto hračkou.  
 HU FONTOS: Az elemeket nem szabad módosítani, és a játékhöz adott lövedékek helyett sem szabad másat használni.  
 UA УВАГА: Ніколи не модифікуйте елементи. Використовуйте тільки снаряди, що входять у комплект цієї іграшки.  
 HR VAŽNO: Nemojte nikad mijenjati elemente ili koristiti druge projekte osim onih koji bili priloženi uz ovu igračku prilikom kupnje.  
 SR VAŽNO: Nemojte da modifikujete elemente i ne koristite druge projekte osim onih koji dolaze uz ovu igračku.  
 MK ВАЖНО: Никогаш не менувајте ги елементите и не користете други проектили од тие што ви се дадени со играчката.  
 SL POMEMBNO: Nikoli ne spreminjajte elementov in uporabljajte le izstrelke, ki so bili priloženi tej igrači.  
 RO IMPORTANT: Nu modificați niciodată elementele și nu utilizați alte proiectile decât cele furnizate cu această jucărie.  
 BG ВАЖНО: В никакъв случай не видоизменяйте елементите и не използвайте други снаряди освен предоставените с тази играчка.  
 LV SVARĪGI: Nekad nepārveidojiet rotālietas elementus, vienmēr izmantojiet tikai tās komplektā iekļautās lodītes.  
 ET OLULINE: Mänguasja osi ei tohi teistega asendada, kasutada võib ainult kaasasolevat heitkeha.  
 LT SVARBU: Niekuomet nekelskite elementų ir naudokite tik tuos šovinius, kurie yra pridėti prie šio žaislo.  
 TR ÖNEMLİ: Hiçbir zaman parçalarda değişiklik yapmayın veya bu oyuncakla verilenler dışında fırlatıcılar kullanmayın.  
 AR ملاحظة مهمة: تجنب تعديل العناصر أو استخدام مشذوفات أخرى خلاف المرفقة مع هذه اللعبة.  
 ID PENTING: Jangan pernah memodifikasi elemen atau menggunakan pelet lain selain yang disediakan bersama mainan ini.  
 MS PENTING: Jangan ubah suai elemen atau guna peluncur lain selain daripada yang disediakan untuk alat mainan ini.

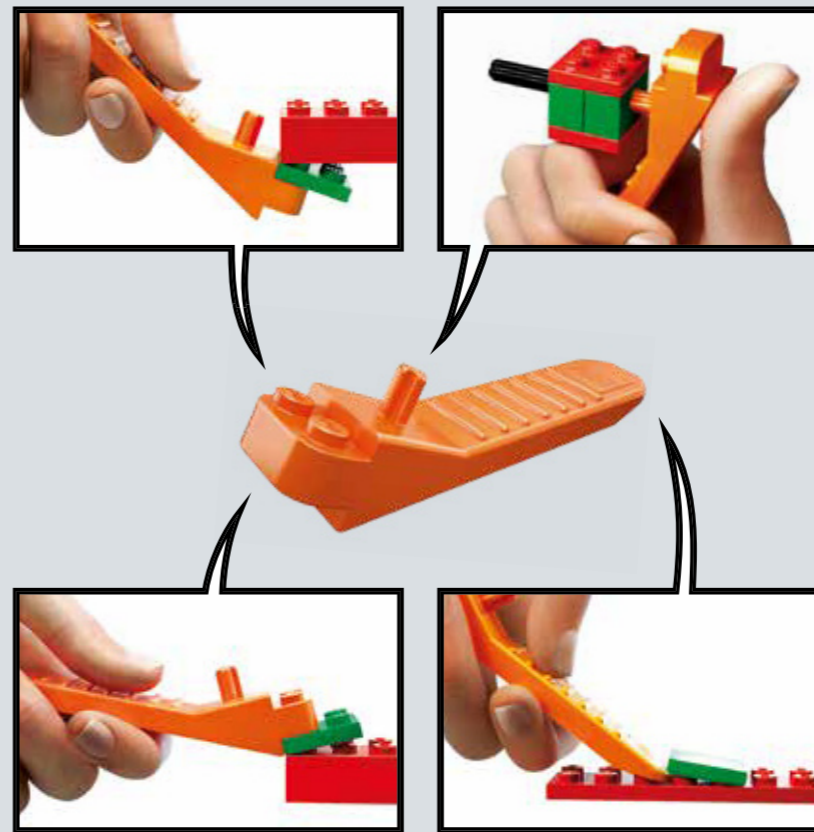
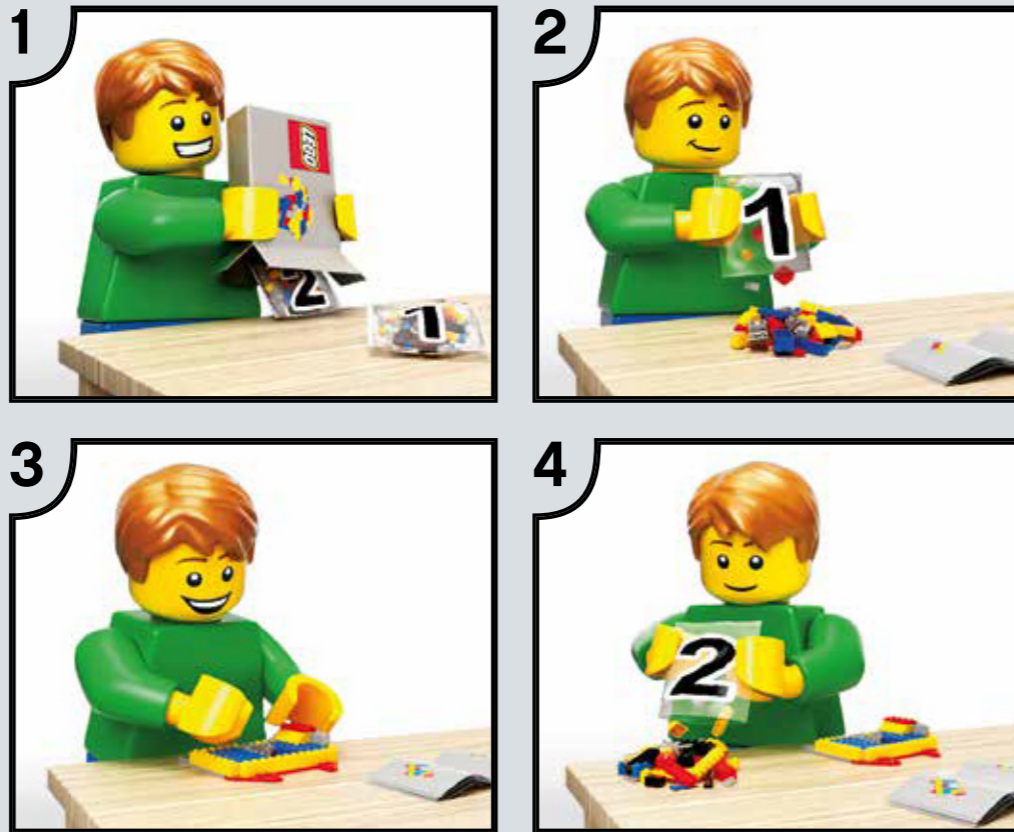

[LEGO.com/brickseparator](https://LEGO.com/brickseparator)

# About the LEGO® Star Wars™ Design Team

LEGO® Star Wars started in 1999 and we have been making new models for the product line every year since then. The LEGO Star Wars design team consists of eight model designers and four graphic designers. The team is a mix of brand new designers with new, fresh ideas and experienced LEGO Star Wars designers with many models under their belts.

This is an ideal team for creating new, innovative LEGO Star Wars models, as well as revising and improving previous LEGO versions of classic and iconic Star Wars ships. The focus of our main LEGO Star Wars product line is to make cool, fun, and inspiring LEGO Star Wars models for children.

With LEGO Direct, we have the opportunity to make even bigger, more challenging models with special attention to accuracy and details. These models are fun and exciting to develop, as well as a huge challenge! We always do our very best, and hope you will enjoy building them.

Happy building!



**Jens Kronvold Frederiksen**  
Design Director, LEGO® Star Wars™

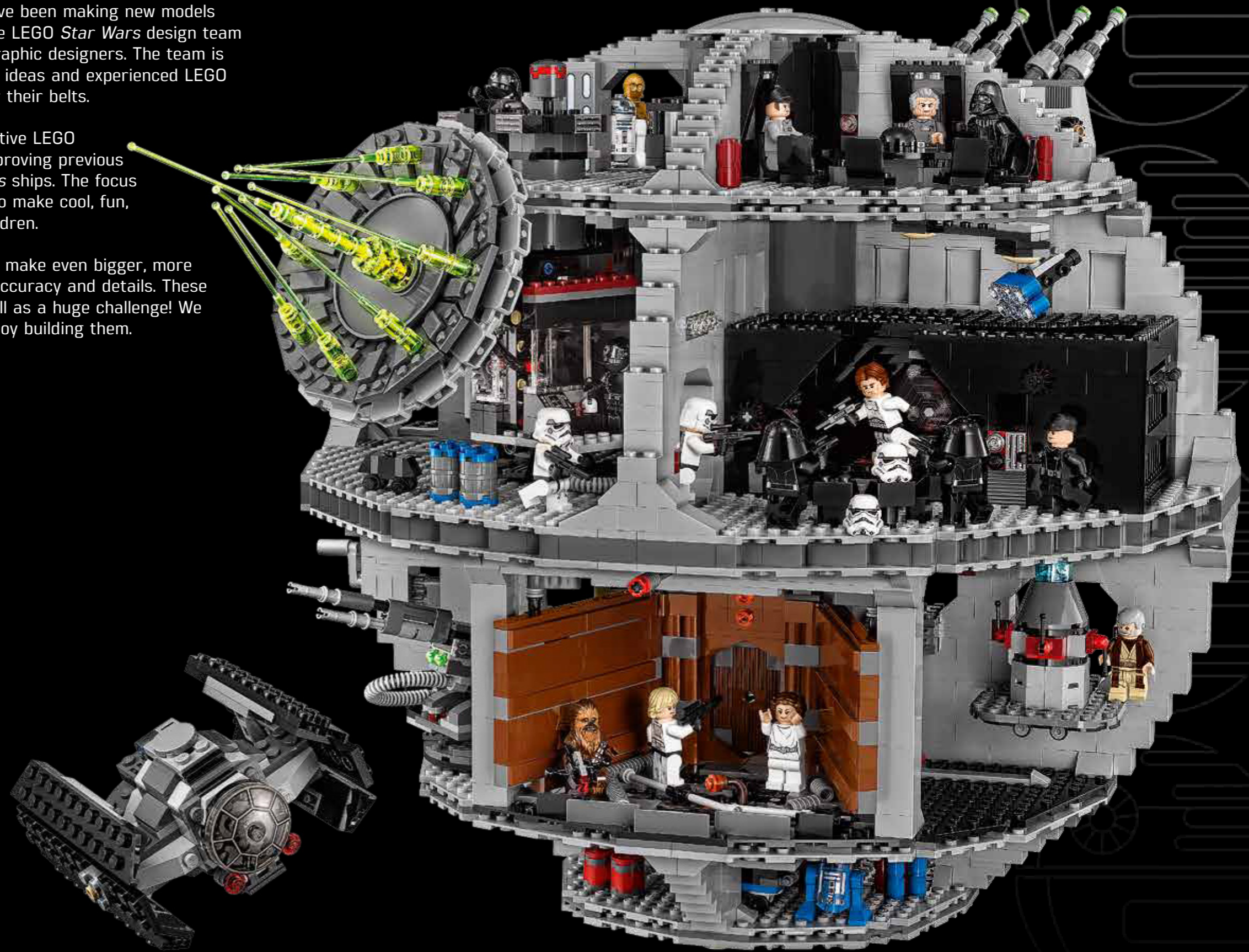



## About the Death Star

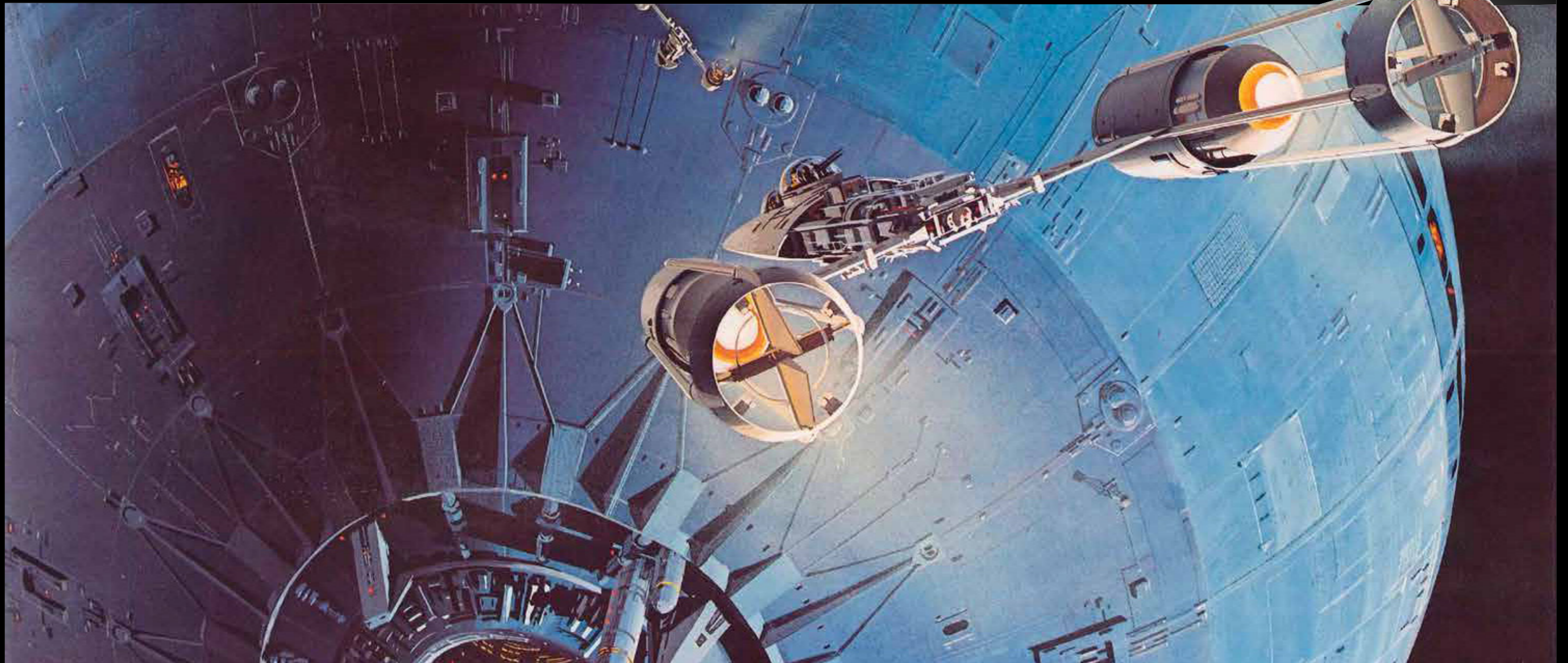

© & ™ Lucasfilm Ltd.

The ultimate weapon of terror, the DS-1 Orbital Battle Station colloquially known as the Death Star, became one of the most effective weapons in the arsenal of the Galactic Empire. Prior to its eventual destruction by the Rebel Alliance led by the young Jedi Luke Skywalker, the Death Star earned its infamy by crushing resistance through sheer size and might, as well as the total destruction of Leia Organa's homeworld, Alderaan.

Supreme Chancellor Palpatine, with assistance from the Geonosians, plotted to build the first dreaded Death Star – a weapon unlike anything the galaxy had ever seen. Palpatine, secretly the Sith Lord Darth Sidious, had his apprentice Darth Tyranus (also known as Count Dooku) deliver the plans from Geonosis to Coruscant at the start of the Clone Wars. The Death Star secretly took shape in space above Geonosis. Access to the former Separatist world was restricted, with very few in the Imperial hierarchy allowed to know about the battle station's construction.

The Empire appointed Wilhuff Tarkin to oversee the project. Tarkin proved a capable commander, and Palpatine rewarded him by making him a Grand Moff with greater control over the project. Tarkin would become the battle station's greatest champion, seeing it as the key to vanquishing all resistance to Palpatine's rule.

The Death Star's downfall began with Leia Organa rescuing a series of blueprint layouts and plans for the Death Star, and realizing the importance of the plans' survival, placed them inside Astromech droid R2-D2 who, along with his companion C-3PO, were purchased by Owen Lars from scavenging Jawas. Located by Luke Skywalker, and later Obi-Wan Kenobi, the plans inside R2-D2 were key in the Rebel Alliance's discovery of the Death Star's one major weakness: an exhaust shaft that led directly into the Death Star's main reactor.

This weakness was exploited by Luke Skywalker who piloted an X-wing down to the surface of the Death Star, and utilizing the Force, fired two proton torpedoes down into the exhaust shaft, destroying the Death Star entirely. This proved to be a decisive victory for the Rebel Alliance, and not long after, thousands of star systems began to align with the Alliance. Unbeknownst to the Rebels however, Emperor Palpatine had ordered the construction of a second Death Star only days prior to the first's destruction.

## Facts/Specifications

### Death Star Facts

Manufacturer.....Imperial Department of Military Research  
 Sienar Fleet Systems  
 Model.....DS-1 Orbital Battle Station  
 Class.....Deep-space mobile battle station

### Technical Specifications - DS-1 Orbital Battle Station

Diameter.....160 kilometers  
 Armament.....Concave Dish Composite Beam Superlaser  
 Taim & Bak D6 turbolaser batteries (5,000)  
 Taim & Bak XX-9 heavy turbolasers (5,000)  
 SFS L-s 4.9 laser cannons (2,500)  
 Borstel MS-1 ion cannons (2,500)  
 SB-920 laser cannons  
 Phylon tractor beam generators (768)  
 Charged-particle blasters  
 Magnetic railguns  
 Proton torpedo banks  
 Surface cannon  
 Engine Unit.....Sepma 30-5 sublight engines  
 Crew.....Full-time crew members (342,953)  
 Officers (27,048)  
 Troops (607,360)  
 Pilots (167,216)  
 Support and maintenance crew (285,675)  
 Support droids (400,000)  
 Stormtroopers (25,984)  
 Gunners (57,278)  
 Starship support staff (42,782)  
 Cargo capacity.....over 1 million kilotons

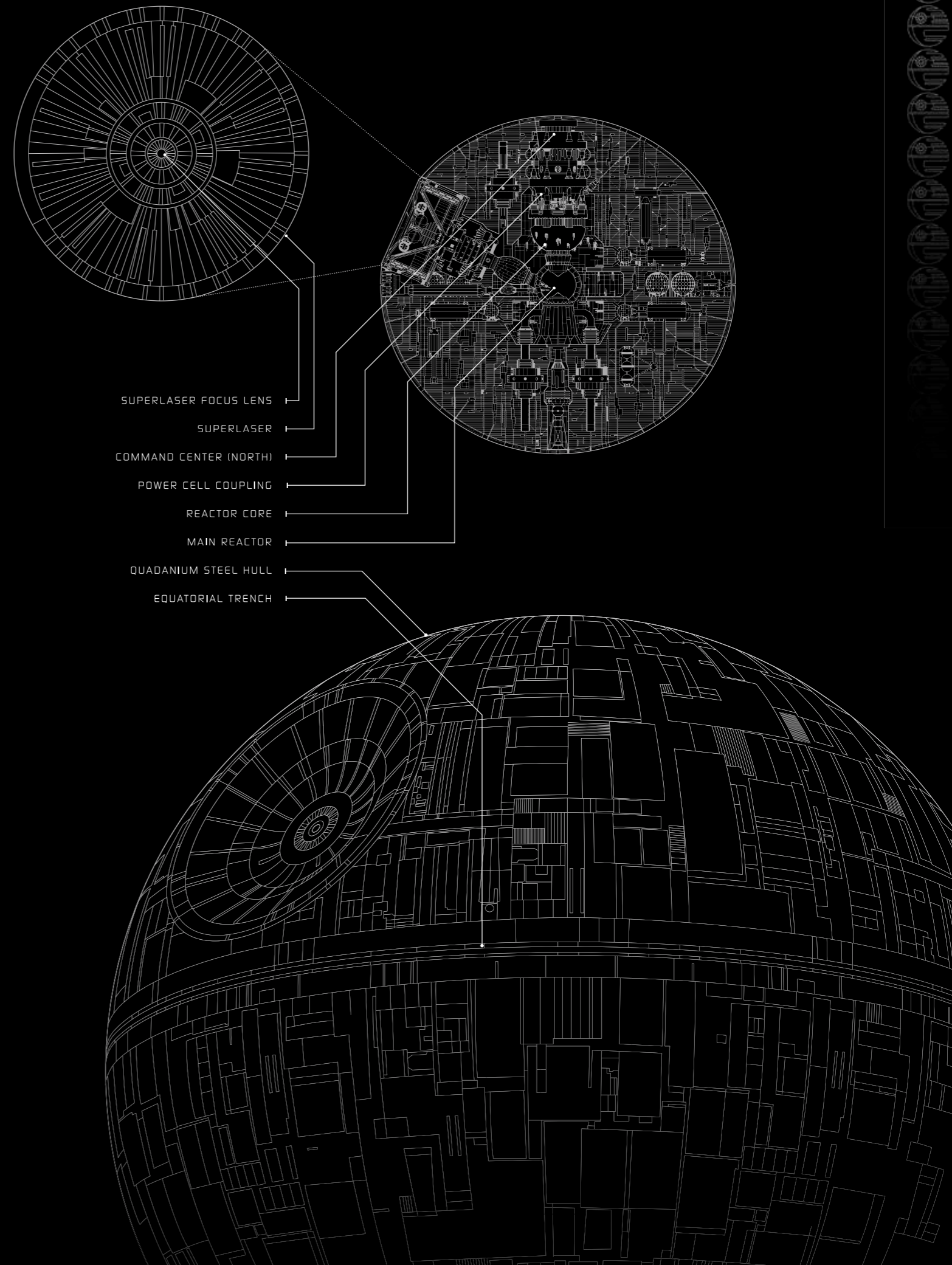

# Death Star Compartments

## Rotating Turbolaser Turret

## Emperor's Throne Room

When Luke Skywalker was captured he was brought to the second Death Star's throne room, where Palpatine tried to convert the young Jedi to the dark side of the Force. When he refused to join the Sith, Emperor Palpatine used Skywalker's anger to instigate a duel between Darth Vader and Luke Skywalker in the throne room.

## Air Duct

## Central Core Shaft

The Central Core Shaft houses the Death Star's air shaft and central turbolift shaft. Luke Skywalker and Princess Leia Organa used a grappling hook to swing across the chasm inside this room during Leia's rescue.

## Droid Repair Center

Littered with spare parts and advanced machinery, the Droid Repair Center is where droids aboard the Death Star are maintained and fixed as well as upgraded and improved.

## Docking Bay 327

One of many hangars in the Death Star that are used to store ships that have been dragged in via the Death Star's tractor beam.

## Cargo Bay

## Storage Bay

## Central Turbolift Shaft

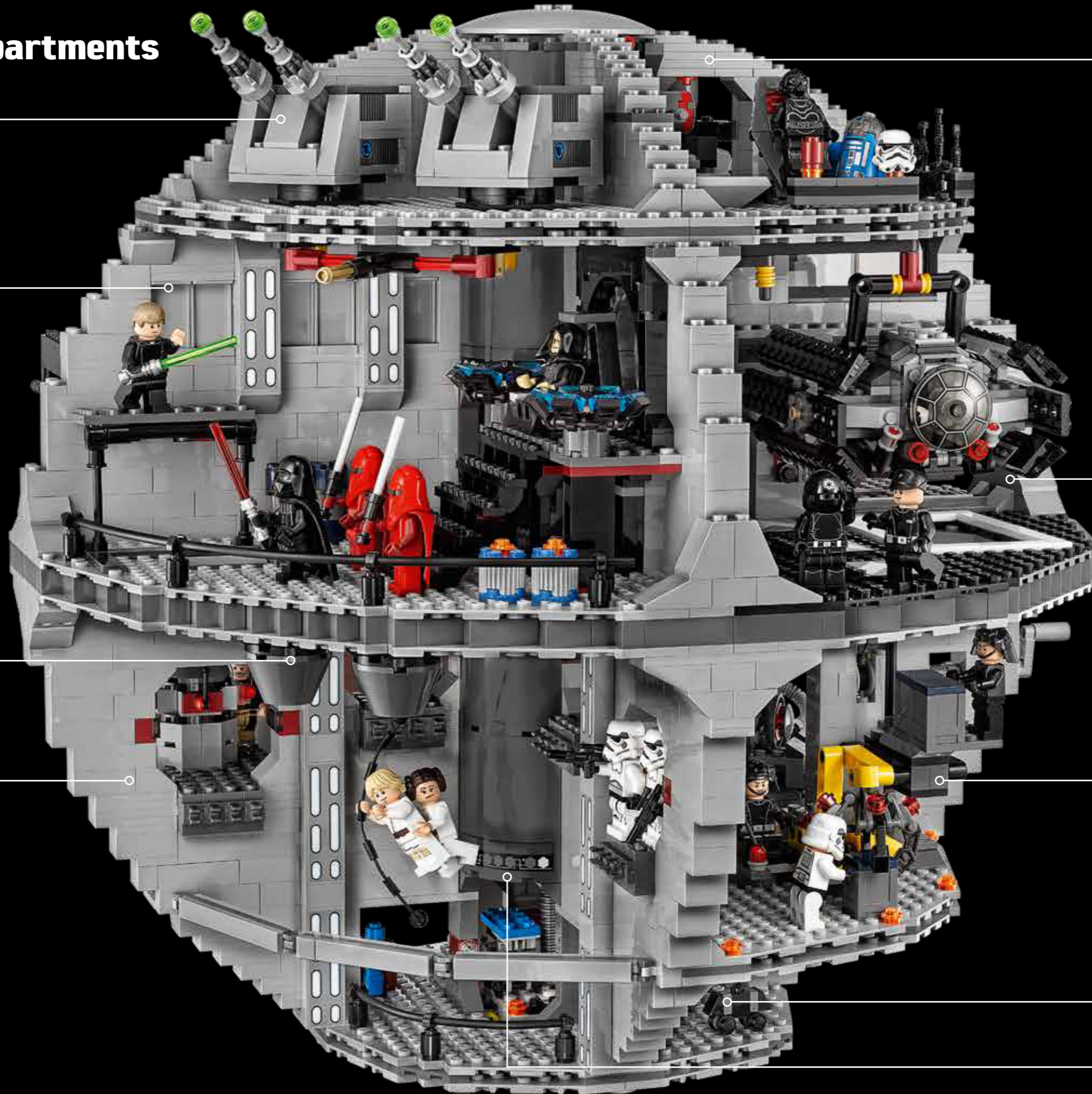

### Superlaser Fire Control Room

This chamber in Theta Sector of both Death Stars is where the superlaser controls are situated.

### Conference Room

This is where leaders of the Galactic Empire would meet aboard the Death Star, and is also where Darth Vader choked Admiral Motti.

### Security Camera

### Cell 2187

Cell 2187 in Detention Block AA-23 was where Princess Leia Organa was imprisoned by Darth Vader for suspected Rebel activities.

### Level 6 Core Shaft Corridor

The Level 6 Core Shaft Corridor is a walkway across the tractor beam power generator trench on the Death Star. It was here that Obi-Wan Kenobi took out Docking Bay 327's tractor beam, ultimately allowing the Millennium Falcon to flee.

### Tractor Beam Reactor Coupling

### Superlaser Firing Dish

### Rotating Turbolaser Turret

### Trash Compactor 3263827

Upon freeing Princess Leia Organa from the original Death Star's detention level, Han Solo, Chewbacca and Luke Skywalker were temporarily stranded inside this trash compactor along with the princess. They were attacked by a carnivorous dianoga, and nearly died when the compactor's walls started to close in to compress the waste it contained. C-3PO and R2-D2, who had remained behind in safety however, managed to disable all trash compactors on the detention level of the Death Star and save their lives.

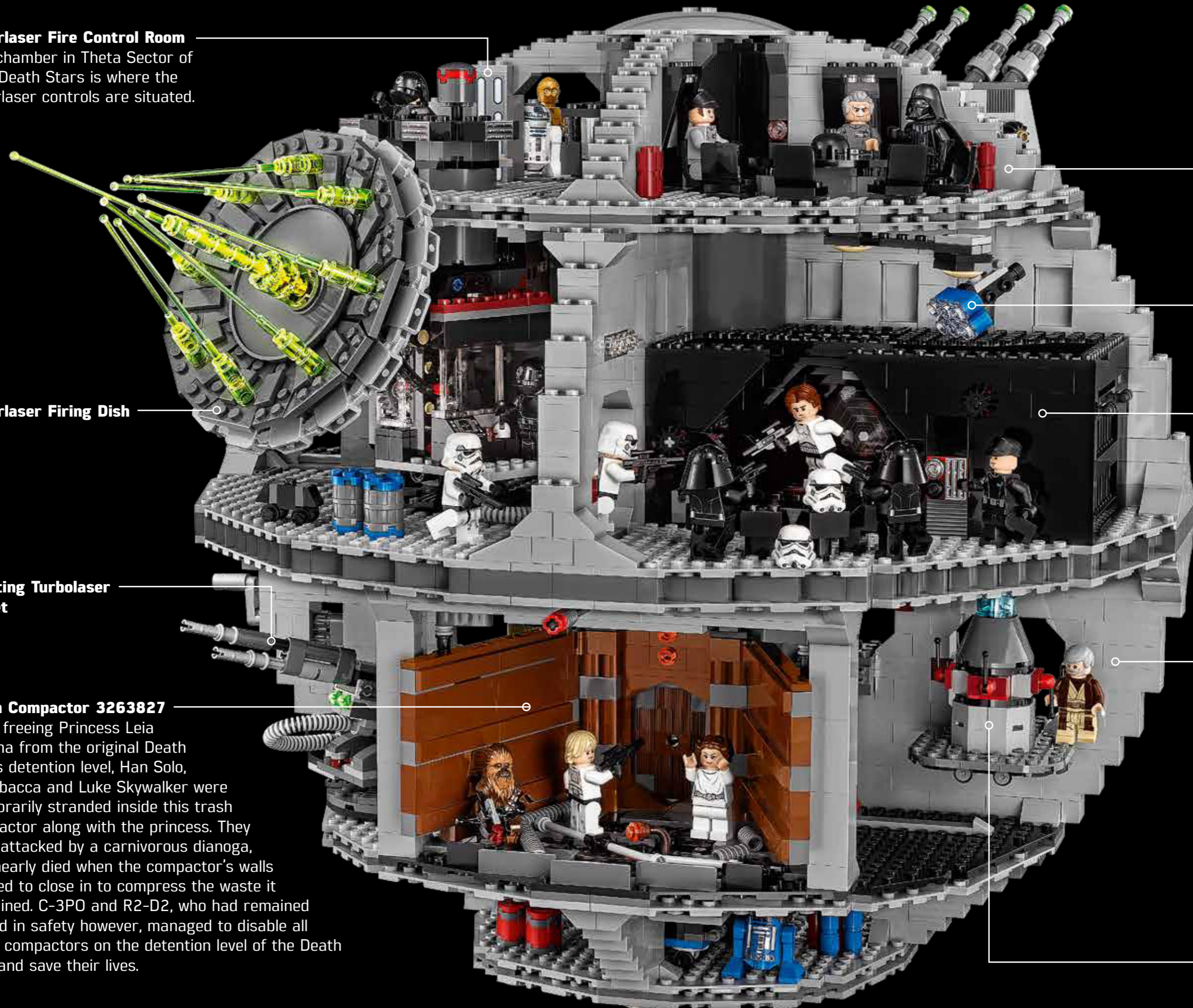

# Meet the Model Designer

## Niels Mølgård Frederiksen

**Q: The LEGO® Star Wars Death Star is one of the most recognizable battle stations from the entire Star Wars canon. Known for its iconic round shape, how did you begin designing this model?**

**A:** I started by looking into what was great about the last incarnation of the Death Star, and which areas could be updated. I especially looked at the different functions to see if they could be improved. Besides that, I really dived into the overall building experience and how this could be improved, to ensure that building this set will be a great experience for everybody.

**Q: What kind of reference material did you use to begin designing the Death Star?**

**A:** I used the two movies featuring both Death Stars (“Star Wars: A New Hope” and “Star Wars: Return of the Jedi”), plus all the screenshots I could make or find to get an overview of the rooms and scenarios.

**Q: What kind of building techniques do you frequently use when designing a model of this scale?**

**A:** Stability is always an important feature for us when we design the models, but especially for models this size the emphasis is on stability, simply because of the weight and size of the model. In this set there’s a lot of stacking bricks, so it’s super important that both the walls and floors are stable. This ensures that the model is stable during the build phase and also afterwards when being played with.

**Q: One of the best features of the LEGO Star Wars Death Star are the rooms on the interior of the model. How did these factor into your design process when creating a model that needs to be functional while remaining stable?**

**A:** The rooms were very much given from the last incarnation of the model – however, I did work with optimizing the walls and floors for a better build flow. Securing stable walls and floors are key here, because once you start adding functions in or through walls or floors, you often remove stability. So ensuring that the model doesn’t get any weak spots (like exhaust ports) while adding lots of playable functions is really important and a big part of the challenge of designing a model like this.

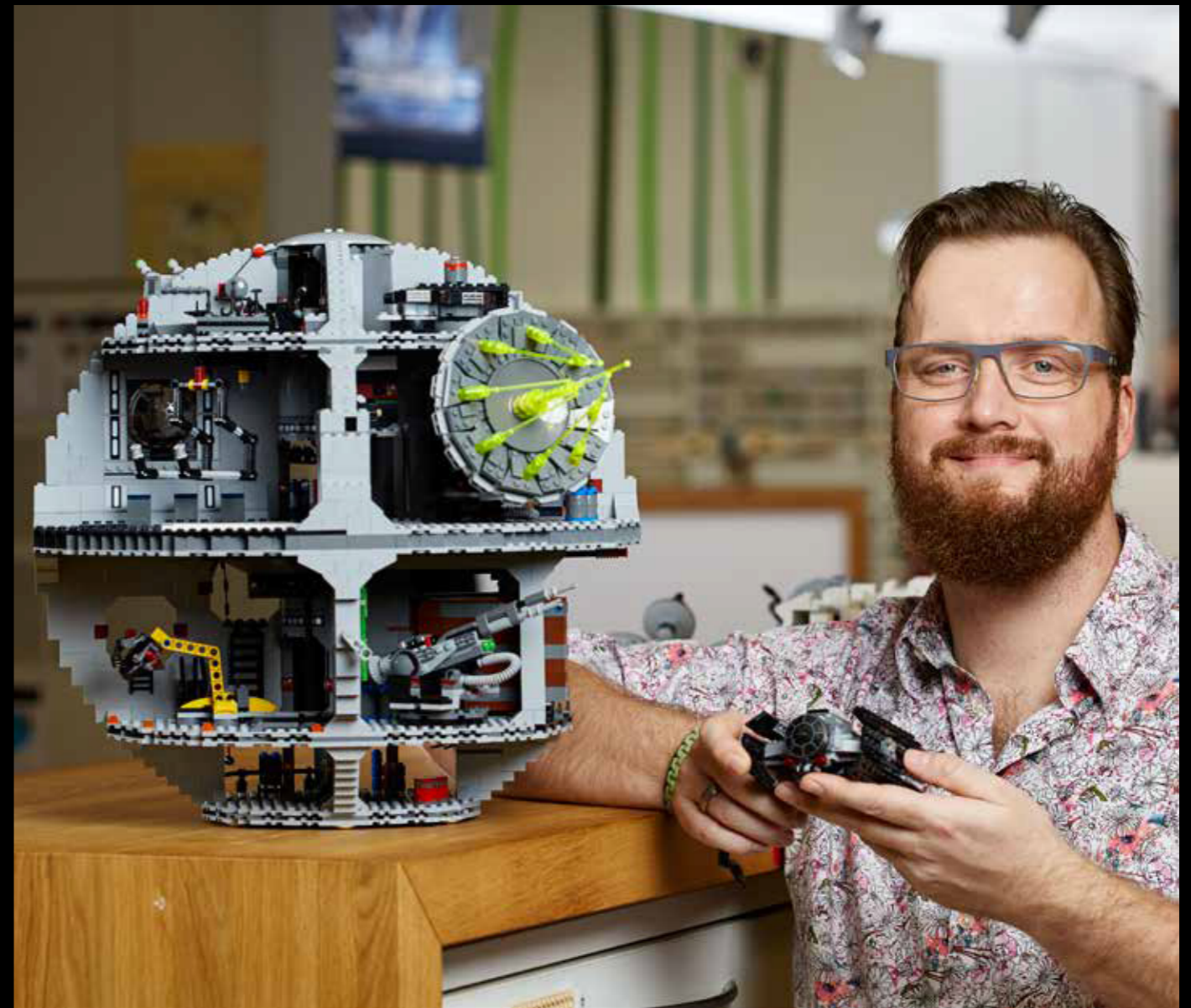

Niels Mølgård Frederiksen

**Q: Is there a specific feature of the model that you enjoyed designing the most?**

**A:** Well the spring-loaded-missile-shooting turbolaser on the lower floor was really fun to design, because that was my design from the ground up. I also came up with a new trigger function for the shooter, so I’m really proud of that part. Besides that, I really like my small tweaks to the turbolasers on the top floor. I love the turbolaser towers in the attack run from “Star Wars: A New Hope”, so putting my fingerprint on those was awesome.

**Q: What is different about this version of the LEGO Star Wars Death Star set from the previous incarnation?**

**A:** A couple of major improvements have been made to the hangar bay elevator, planet killer laser, turbolaser and Darth Vader’s TIE X-1 Advanced. Besides that, a lot of small, more subtle changes have been made throughout the entire battle station.

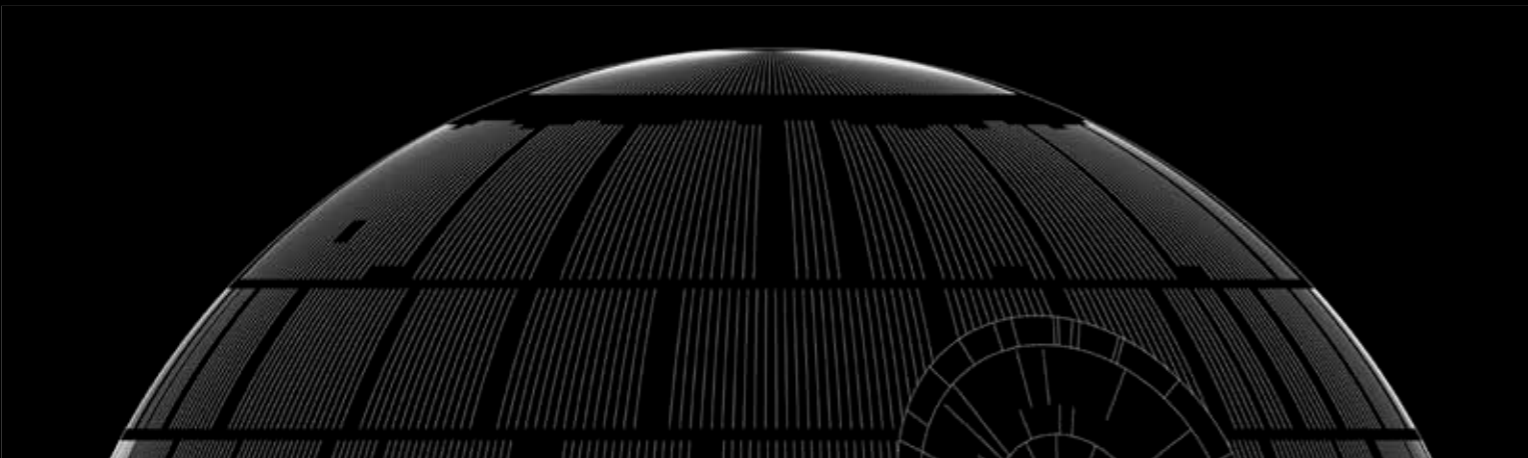



As I designed the new dianoga, I got the idea of adding playability to the trash compactor room. By making a hole in the floor, the dianoga could peek up through as if it was submerged in the muddy water. That task did present some challenges but I'm quite fond of the end result and hope it will add lots of fun to that scenario. Besides that, I've made changes in the building flow and improved the building experience.

**Q: Was there anything unique about designing the round surface of the Death Star while accommodating the planet killer laser?**

**A:** I managed to add more articulation to the planet killer laser in comparison to the previous incarnation. So yes, I of course had to be aware of the confinements, so the planet killer laser's disc wouldn't hit the walls and floors of the Death Star.

**Q: What did you find most challenging about the design for the Death Star?**

**A:** It was probably redesigning Vader's TIE X-1 Advanced to accommodate the Darth Vader minifigure with the new two-piece helmet. The TIE vehicle went through numerous iterations before I had a model where I was satisfied with the design, stability, and building experience.

**Q: Was there anything in your original design that was not included in the final set?**

**A:** No, actually not. Well, minor changes from my original sketches and iterations, but nothing major was left out.

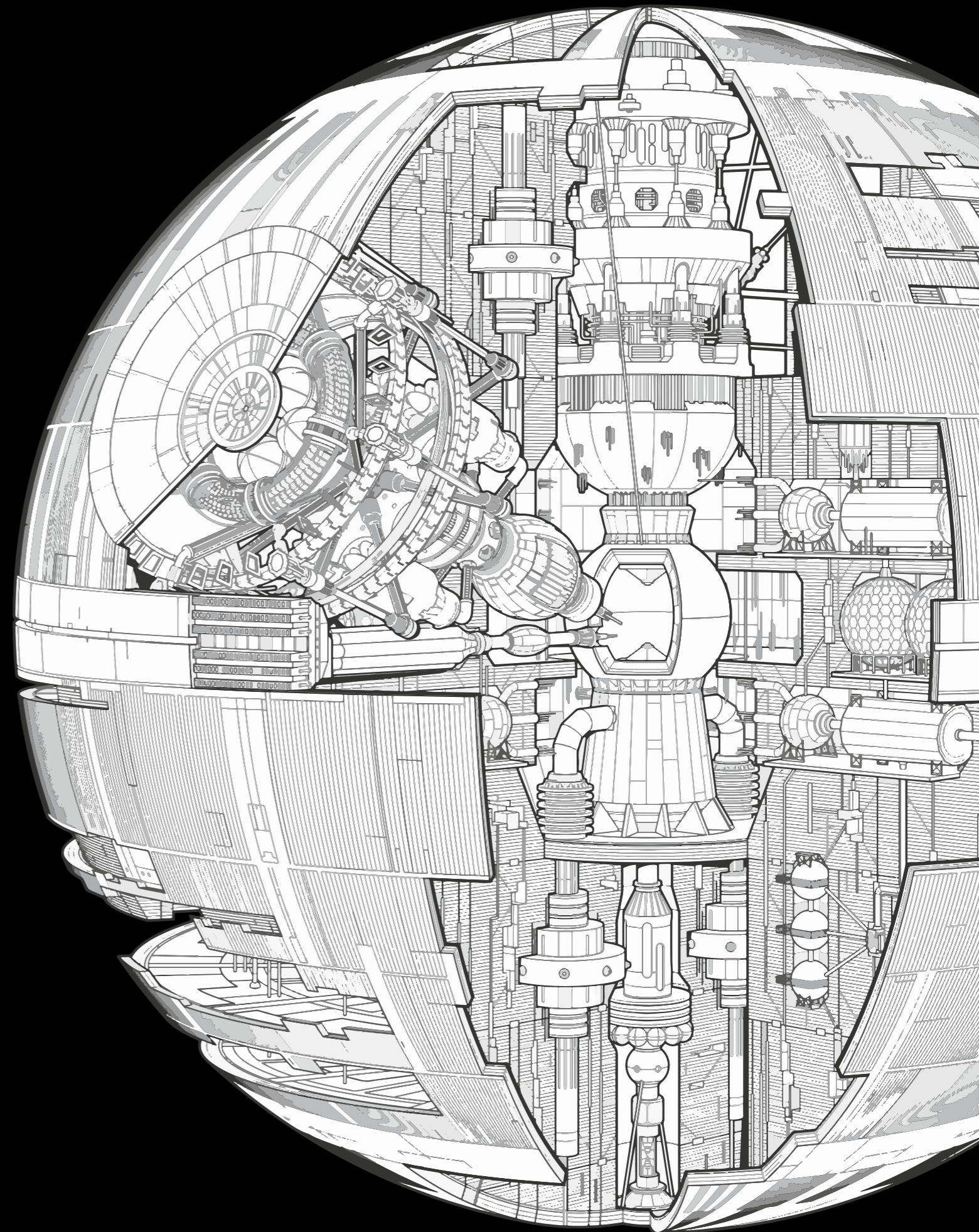

# Meet the Graphic Designer

Jakob Liesenfeld

**Q: What LEGO® Star Wars minifigures have you designed?**

**A:** This would be a very long list, but I will give a few personal highlights: I have designed all kinds of cool armored troops, including all Clone Troopers, Imperial Stormtrooper, Sandtrooper, Scout Trooper, Stealth Trooper and Snowtroopers. I especially enjoyed creating the First Order Stormtrooper, Flametrooper, TIE Fighter pilots, and the Imperial AT-AT pilot. I also did lots of Officers and Crewmen, both Imperial and Rebel. I have designed almost all the Old Republic minifigures, including the unique Jedi Knights and Sith Warriors; then I have done lots of Astromech and Protocol droids, many aliens and bounty hunters, and of course many heroes ranging from Padmé and Anakin to Hera and Kanan, and sometimes new characters like JEK-14.

**Q: What kind of reference material did you use to begin designing the decorations for LEGO Star Wars minifigures?**

**A:** We get a lot of reference material from our partners at Lucasfilm, from the first concept sketches to the final costumes and props. And of course we use the movies and our knowledge of the characters in order to get across their personality!

**Q: What are some of the challenges you face when designing art for a small surface like a LEGO minifigure?**

**A:** I always try to capture as many details as possible from the amazing originals, but at the same time keep the design on the minifigures as clear as possible. Especially on the minifigure torsos, you should be able to understand the overall shape, what main objects are there or how things are layered from relatively far away. Then there are some smaller details to discover once you take a closer look!



Jakob Liesenfeld

**Q: The LEGO Star Wars Death Star encompasses many different scenes from multiple Star Wars movies. How did you begin design work on characters like Luke Skywalker and Han Solo who appear more than once in the set in different outfits?**

**A:** To be honest, we have had the main characters' looks established before; so we mostly used existing designs, although we did do a badly-needed update for Leia's classic white outfit. And of course we were finally able to create a proper hairpiece for Han Solo!

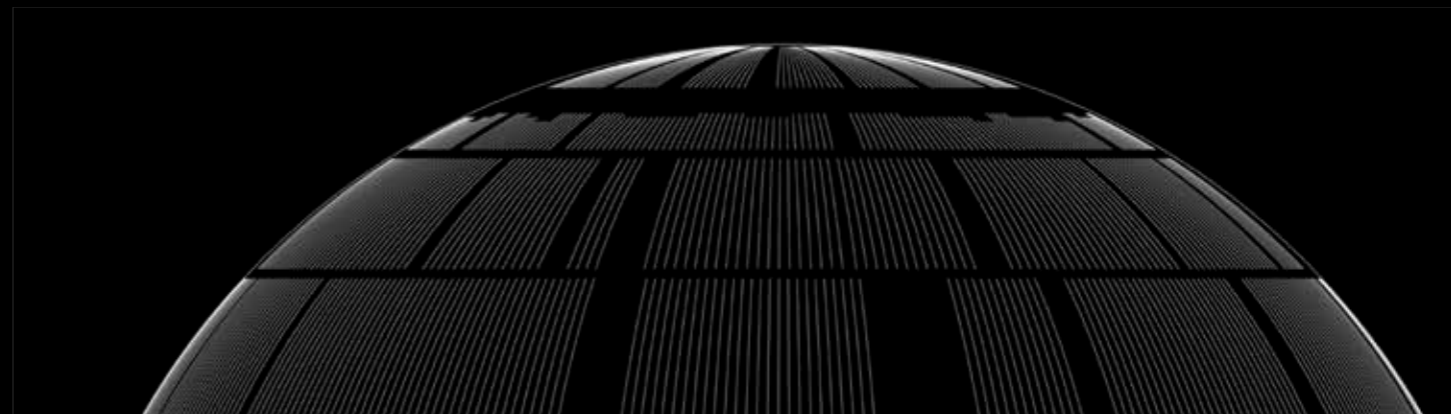



© & ™ Lucasfilm Ltd.

**Q: What is your method for determining which details are important enough to be included in the final design of a minifigure deco, and which details can be simplified?**

**A:** Normally we look for the most iconic parts of a costume. Of course for many fans every detail is important, and we are big *Star Wars* fans in the team! We often simplify details that would get too small, or when we need to adapt the human proportions to the ones of the minifigure. The Stormtrooper for instance has a very short belly, to properly show the bulk and form of the chest armor and belt.

**Q: Is there a part of the design process that you enjoy most?**

**A:** While I really enjoy solving all the little problems along the way, I think that what I like the most are the very big ideas at the start, when we make the decisions about which characters to include and how to approach them. It is also great to look back at the humble beginnings at the end, when I am holding the final prints in my hand.

**Q: How do you begin to create your first initial design when you start a new project?**

**A:** At the start, I would usually do a hand sketch. This helps determine what to focus on and what to leave out, as I mentioned earlier. After that I will work on top of it using vector graphics, and match important lines as closely as possible to the reference.

**Q: Which minifigure in this set did you find most challenging to design and why?**

**A:** This would once again be the Stormtrooper. With this super-iconic design you just have to get it right. Especially the helmet proved to be quite a challenge, since the element itself is of an older generation and full of sculpted details that can conflict with the printing. The wonderful people in our print department had to endure many loops, until we finally found the right placement and distortion to ensure that every detail would land in the right place on the final piece!

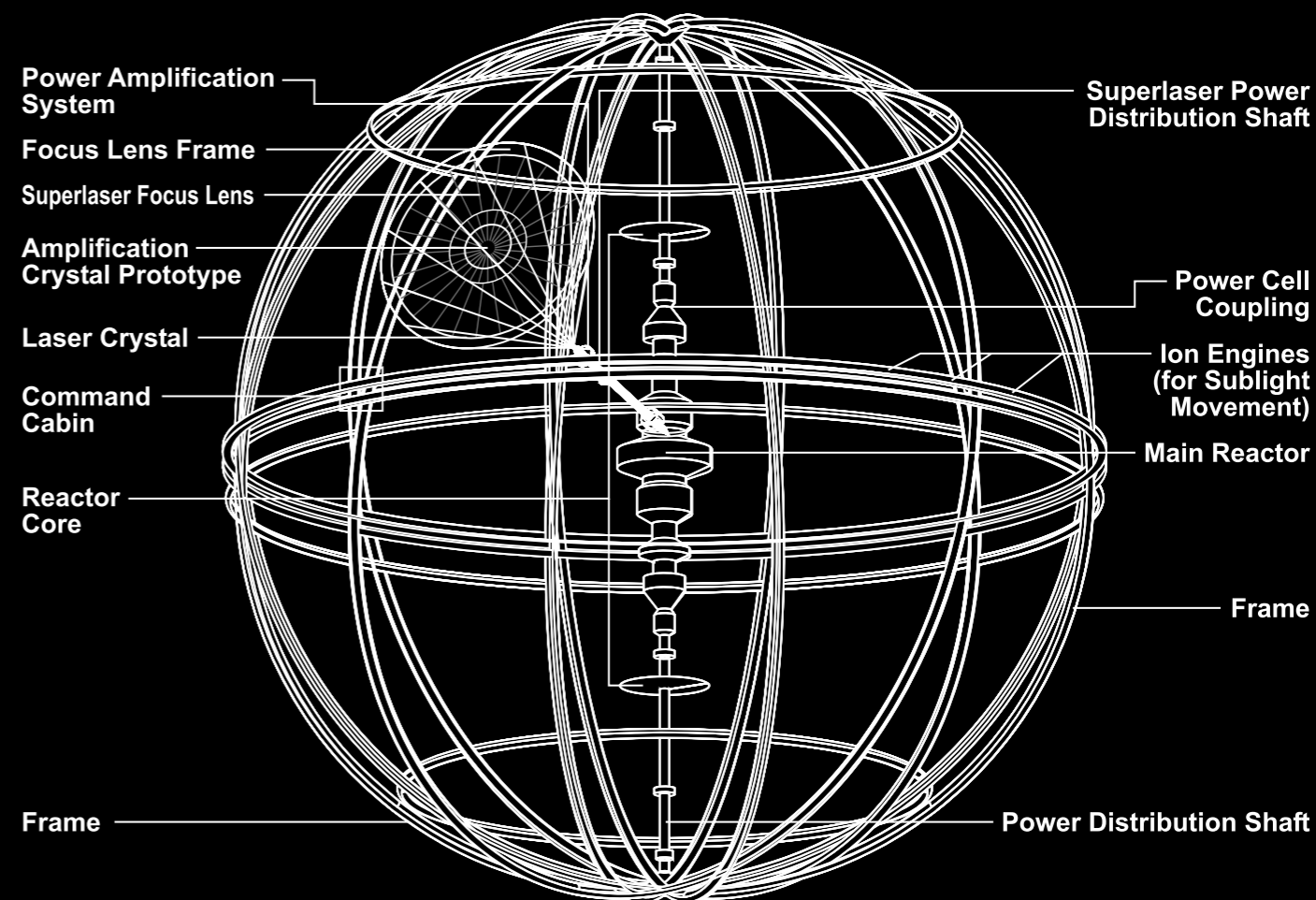

© & ™ Lucasfilm Ltd.



# Meet the Art Director

**William Colburn Jr.**

**Q: What are you responsible for as an art director working on packaging for LEGO® Star Wars?**

**A:** Our roles are sort of a combination of an art director and graphic designer. Essentially we're responsible for making the packaging look as cool as it possibly can! I'll work with several different artists who help me create different assets - everything from the box's background image to the overall design elements on the packaging. My job is to piece together all of those different assets and create the final box art. We often take a team approach to our work on LEGO Star Wars, and I wouldn't be able to do the best job I can without the rest of the group. Our team is always growing and changing, but I want to give a special thanks to John McCormack, Mike Swiatlowski, Jake Blais, Mike Sion, Sara Gomes, and Peter Cangialosi for being the best team I could imagine... thanks for all your help!

**Q: The LEGO Star Wars Death Star is a huge model with multiple rooms, features, and functions. How did you begin the design process for the box art while taking into account all the details that needed to be included?**

**A:** We're lucky enough to have a good template from the previous version of the packaging, and I'd like to thank Rob Johnson for giving us a great starting blueprint! As with all packaging, we begin our designs based on a brief we receive from our marketing team. The marketers give us suggestions for which elements of the model that they would like to focus on. From there we go into our first layout phase. We try to make the marketer's requests come to life in the most creative ways we can, and also give them some alternative options that we put forward ourselves. The box goes through several rounds of design changes based on feedback from the marketing team and our partners until we have all agreed on the final design.

**Q: What kind of reference material do you use to begin designing the package art?**

**A:** In general, we use lots of different materials ranging from images taken directly from the movies, to any kind of things that we find visually inspiring. One day it might be an awesome poster, the next day it might be a pattern in your morning bowl of cereal... you never know where inspiration will strike! Also, our partners at Disney and Lucasfilm have awesome websites available to us that are filled with images from the Star Wars universe. These websites have tons of behind-the-scenes shots, movie stills, posters, concept art, 3D assets... pretty much anything you can imagine. It's by far my favorite place to look for reference material!



William Colburn Jr.

**Q: What kind of challenges do you face when designing art that will be specifically used for packaging design? Is designing package art for smaller sets different from designing package art for larger sets like the Death Star?**

**A:** The biggest challenge is trying to figure out how to fit everything that comes in the box onto the front of the box without interfering with our logos, product information, and legal text. With the Death Star, it's been a bit easier because it's one large model and all of the minifigures are contained in the model itself. Typically we have several smaller pieces, vehicles, and multiple minifigures, so it can turn into quite a puzzle trying to fit everything in... especially on the smaller boxes! I find the puzzle can be challenging at times, however it can be the most rewarding aspect of the design when you are able to tell a fun story and show off all of the included models and minifigures at the same time.

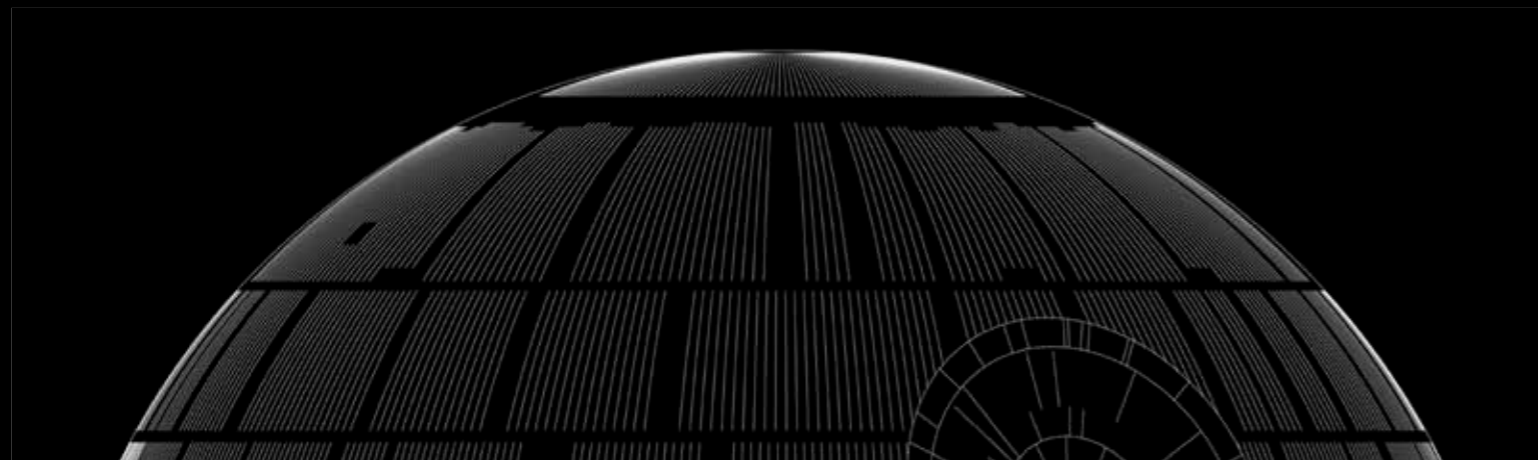

**Q: Were there certain details about this set that were important to you to feature in the packaging art?**

**A:** I really wanted to showcase all of the little details that the model designers included. This is one of the biggest sets in our LEGO® *Star Wars* assortment, but it's essentially made up of a bunch of smaller rooms with all sorts of references to the movies. I especially love the new addition in the trash compactor room that allows the dianoga to stick its head up through the floor!

**Q: The scenes that take place within the Death Star are seminal moments in the *Star Wars* movies. How did you decide which scenes to recreate for the packaging art?**

**A:** We tried to recreate as many scenes as we could for the packaging. However, since the Death Star has so many rooms, it wasn't possible to include every scene we wanted, so we tried to stick with the most iconic and memorable scenes that we could. Most are references from "Episode IV: A New Hope" though my favorite one might be the Lightsaber duel between Darth Vader and Luke Skywalker in the Emperor's throne room from "Episode VI: Return of the Jedi".

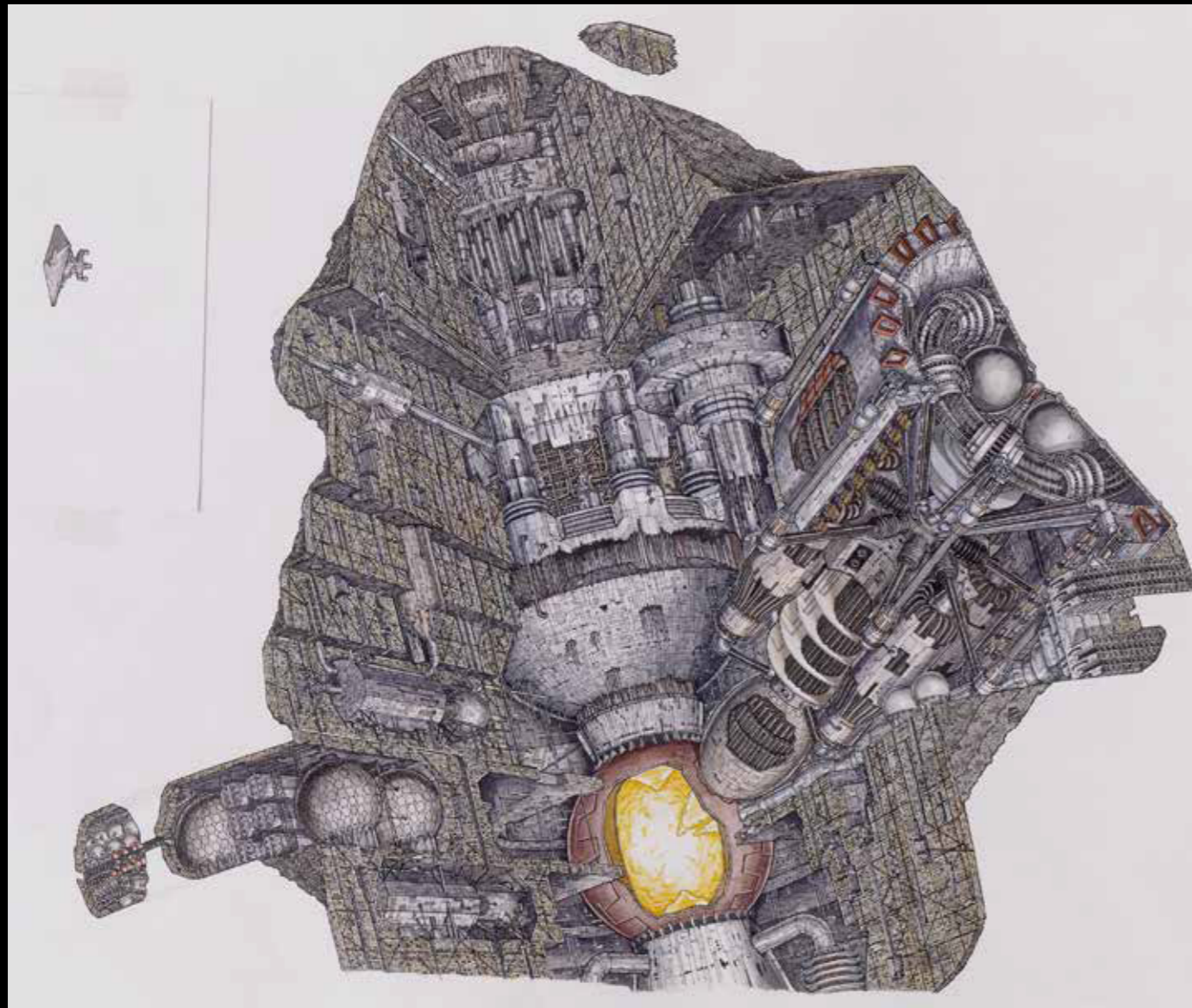

© & ™ Lucasfilm Ltd.

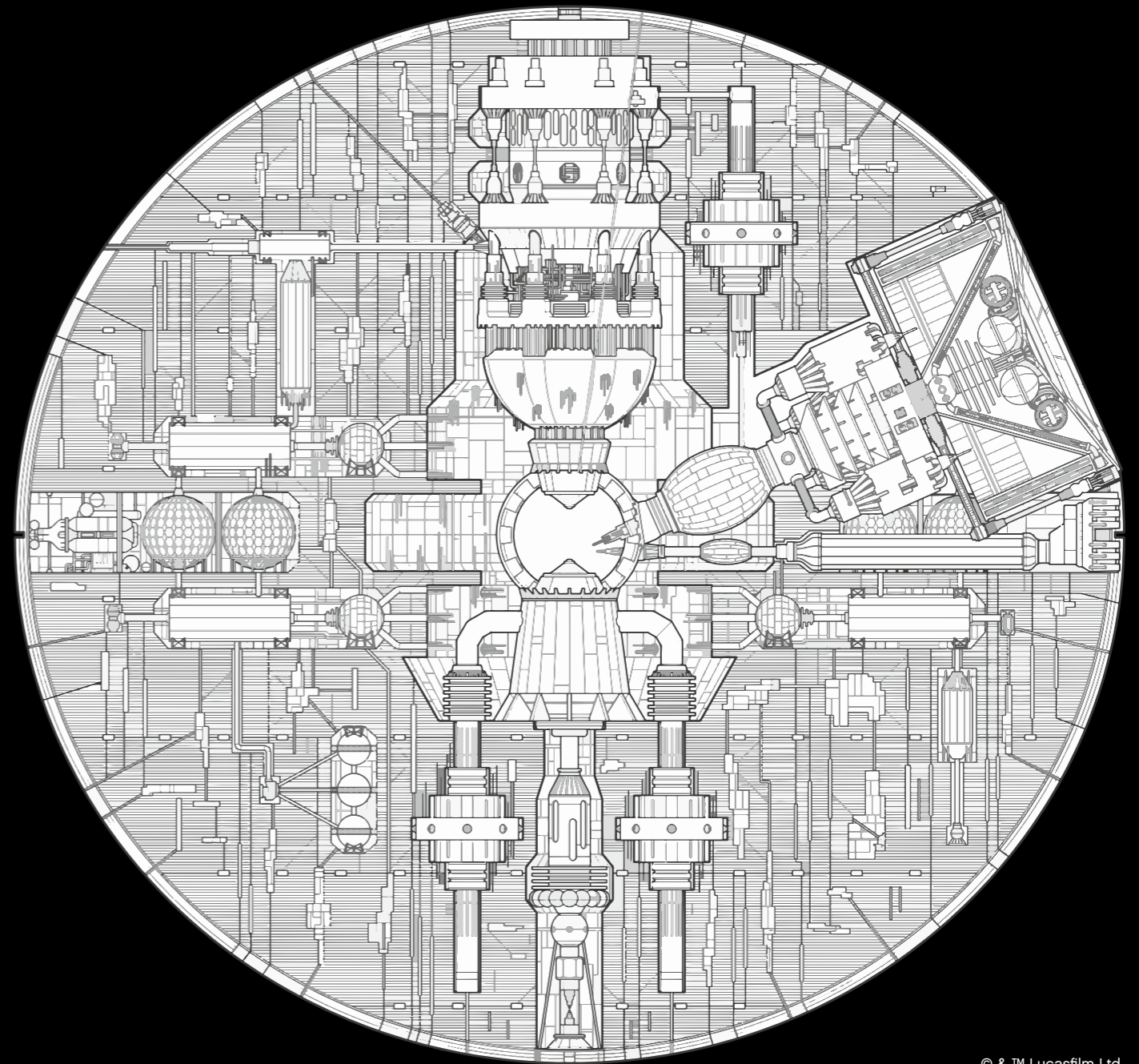

© & ™ Lucasfilm Ltd.

**Q: What do you enjoy most about the design process?**

**A:** By far my favorite part of the design process is final photography. In the digital age, a lot of companies have transitioned over to using 3D renders for their packaging; however we still shoot photos of the actual product. I have a background in photography, so getting to go to these photo shoots is a very fun time for me. With all the gear and camera equipment around, I feel like a kid in a candy store! It can get hectic, as there are a lot of things going on all at once, but the team at Atwater Studios make it an awesome experience. Thanks to Joey, Tim, and Victor for all of your help over the years!

# Character Overview



## Grand Moff Tarkin

Ordered the destruction of Princess Leia's home planet Alderaan. He also placed a tracking beacon on the Millennium Falcon to find the Rebel base.



## Imperial Officer

These officers were skilled and intelligent soldiers who worked their way up the chain of command aboard the Death Star.



## Imperial Navy Officer

These soldiers were higher-ranking officials serving on board the many ships of the Imperial Fleet.



## C-3PO

Protocol droid built by young Anakin Skywalker. His quick reactions aboard the Death Star prevented Luke and friends from being crushed in the trash compactor.



## R2-D2

Astromech droid R2-D2 was instrumental in delivering the Death Star blueprints to the Rebel forces.



## Chewbacca

Han Solo's copilot and best friend, Chewbacca helped Luke and Han stage the daring rescue of Princess Leia Organa.



## Han Solo (disguise)

Sneaking on board the Death Star by posing as a Stormtrooper with Luke, Han Solo was able to find and rescue Princess Leia.



## Luke Skywalker (disguise)

Disguised as a Stormtrooper, Luke Skywalker infiltrated the Death Star with the help of his friend Han Solo to rescue Princess Leia.



## Death Star Gunner

Member of the Imperial Navy's Starfighter Corps with lightning-fast reflexes.



## Death Star Droid

Mechanical beings that often possessed artificial intelligence, droids were often given jobs too dangerous or too difficult for their human counterparts.

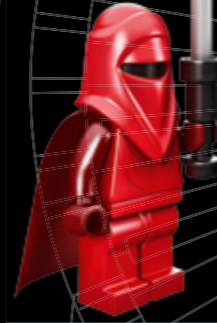

## Emperor's Royal Guard

An elite unit of the Galactic Empire, tasked with the protection of Emperor Palpatine.



## Emperor Palpatine

Leader of the Galactic Empire, but behind closed doors he was in reality, Darth Sidious, the Dark Lord of the Sith who sought to control the Galaxy.



## Luke Skywalker (final duel)

After learning that Vader was actually his father, Anakin Skywalker, Luke returned to the second Death Star to defeat Vader and the Galactic Empire.



## Darth Vader

Loyal to the Galactic Empire, Darth Vader tortured Princess Leia aboard the Death Star into revealing the location of the Rebel base. He later severed Luke's hand in a lightsaber duel.



## Imperial Astromech

Imperial Astromechs were extremely flexible and efficient and could often be found on the battlefield.



## Stormtrooper

The numerous ground troops of the Galactic Empire were well-trained soldiers, highly effective in combat and heavily armored.



## Death Star Trooper

Elite Imperial Navy troopers were specially trained soldiers who were deeply loyal to Emperor Palpatine.



## Han Solo

Pilot of the Millennium Falcon and a well-known smuggler, Han Solo became a key part of the Rebel Alliance.



## Princess Leia

Princess of the planet Alderaan and Rebel Alliance sympathizer, Leia was held captive aboard the Death Star before her rescue by Han Solo and Luke Skywalker.



## Luke Skywalker (Tatooine)

An apprentice Jedi to Master Obi-Wan Kenobi, Luke Skywalker proved to be a leading member of the Rebel Alliance, destroying the Death Star by using the Force to guide his aim.



## Obi-Wan Kenobi

As a Jedi Master and Luke Skywalker's mentor, Obi-Wan Kenobi was a formidable ally against the Galactic Empire.



1

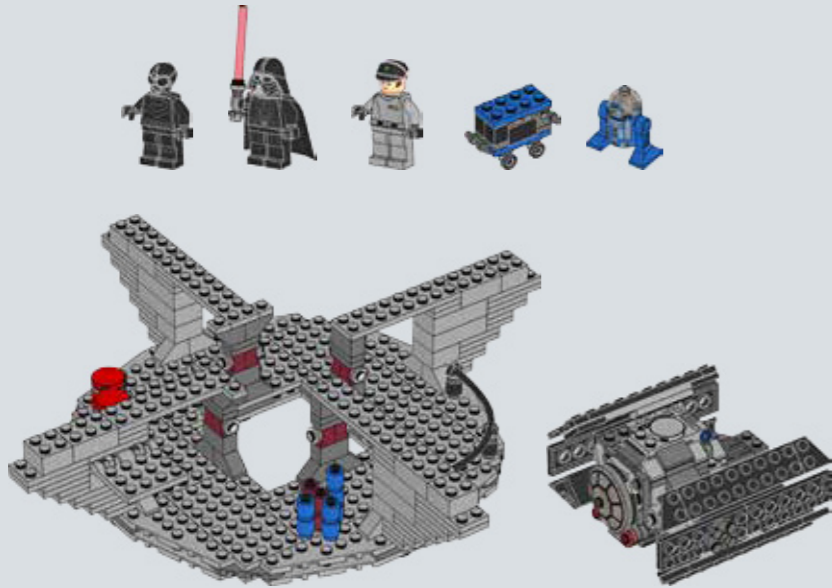

2

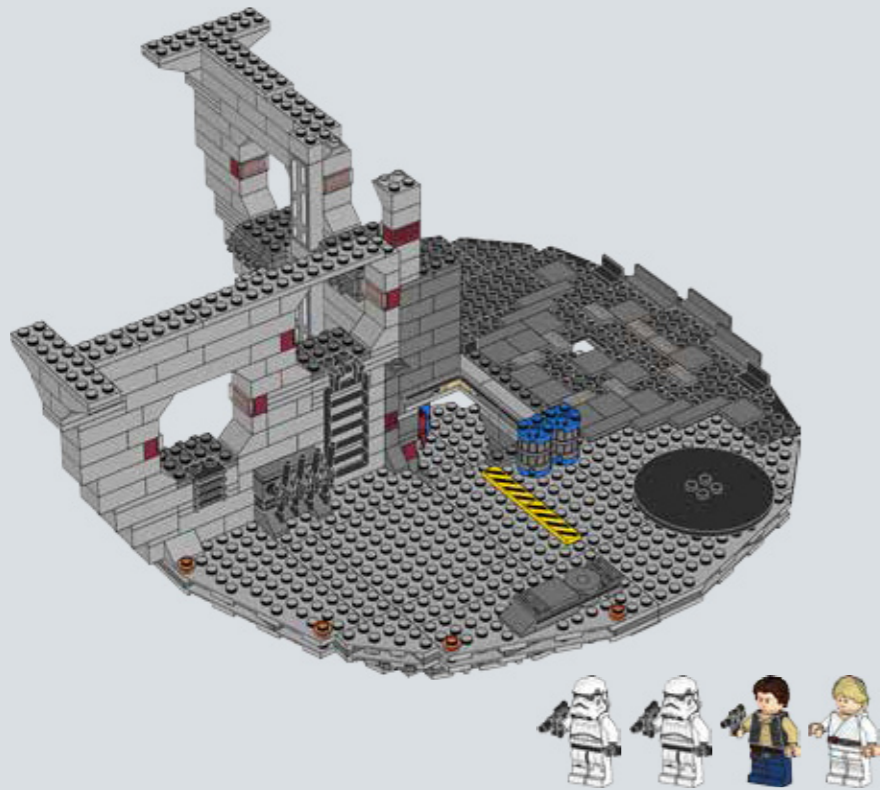

3

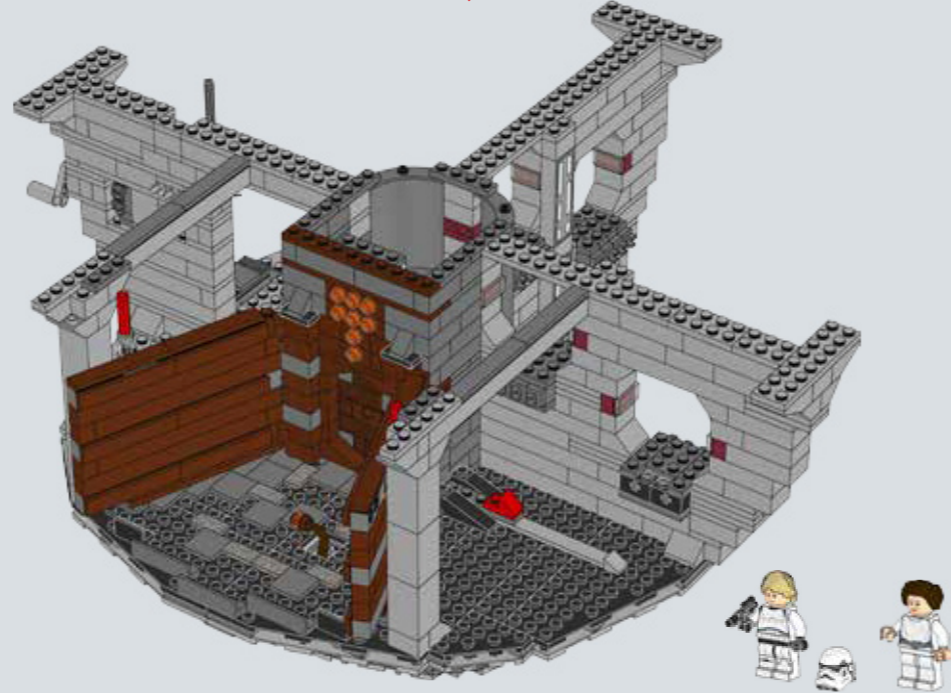

4

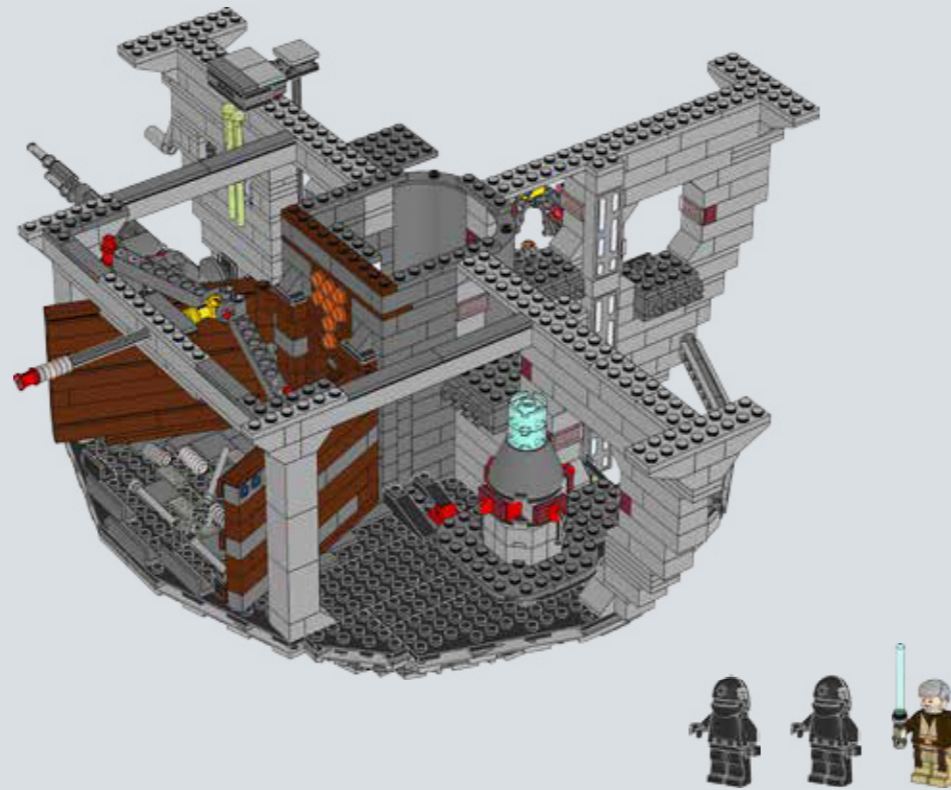

5

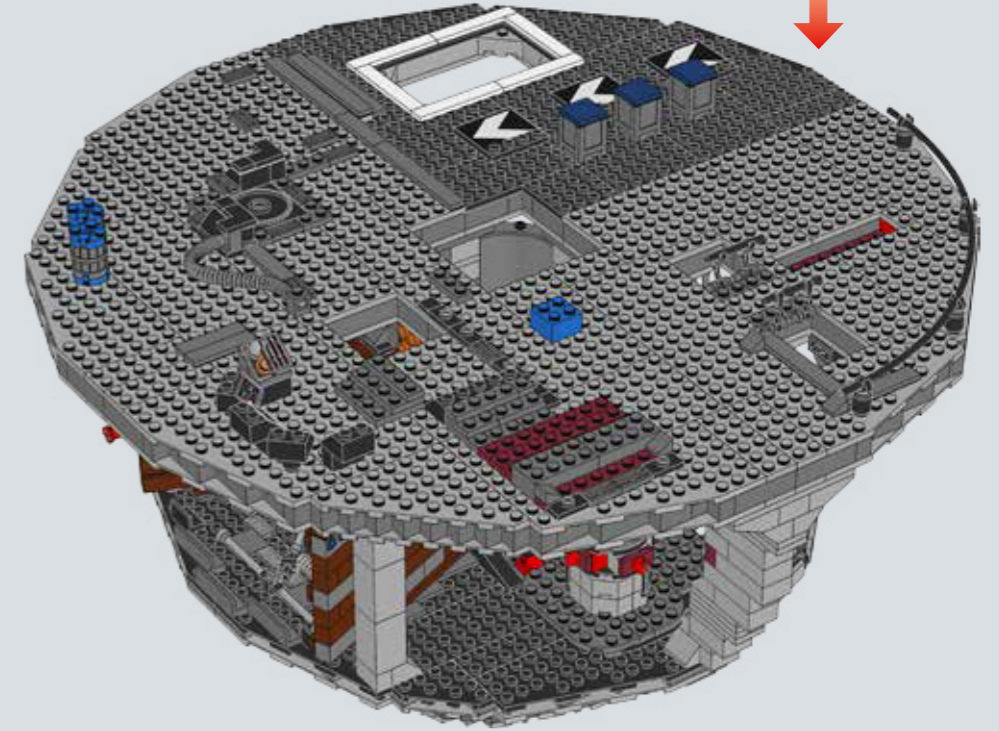

6

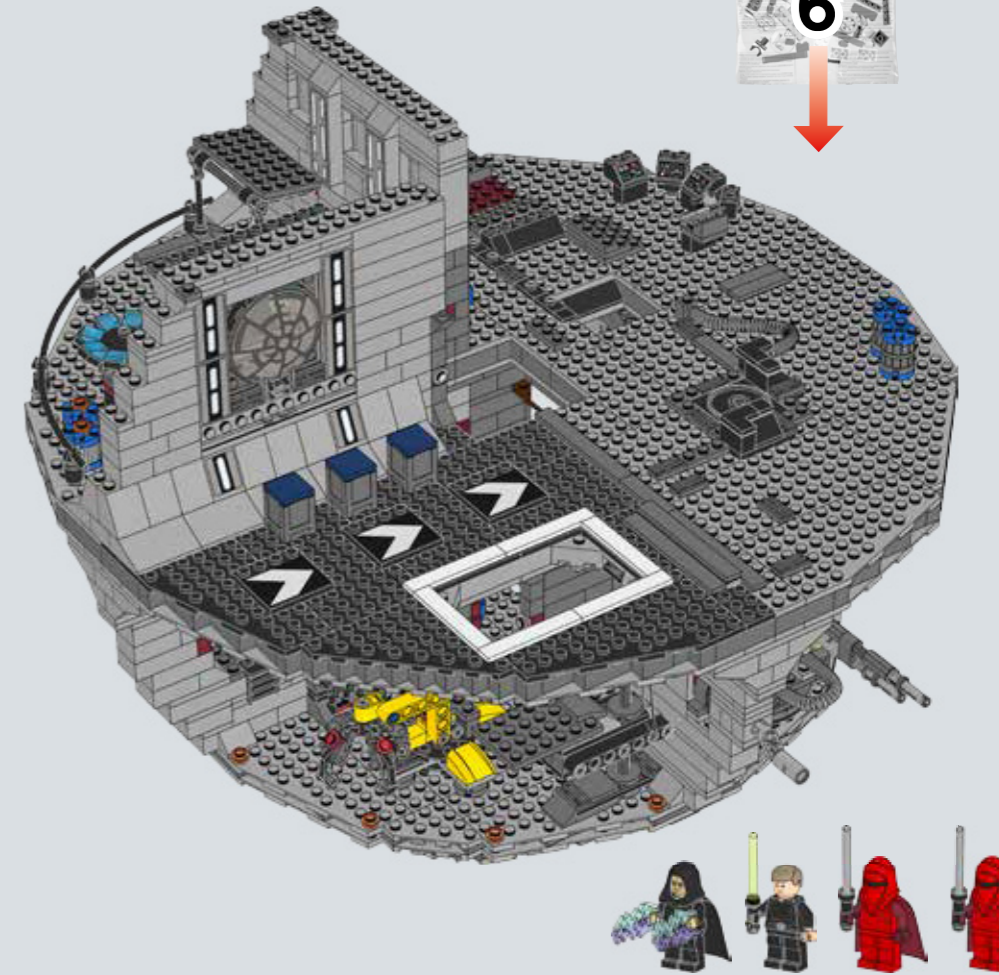



7

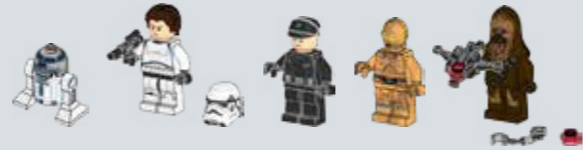
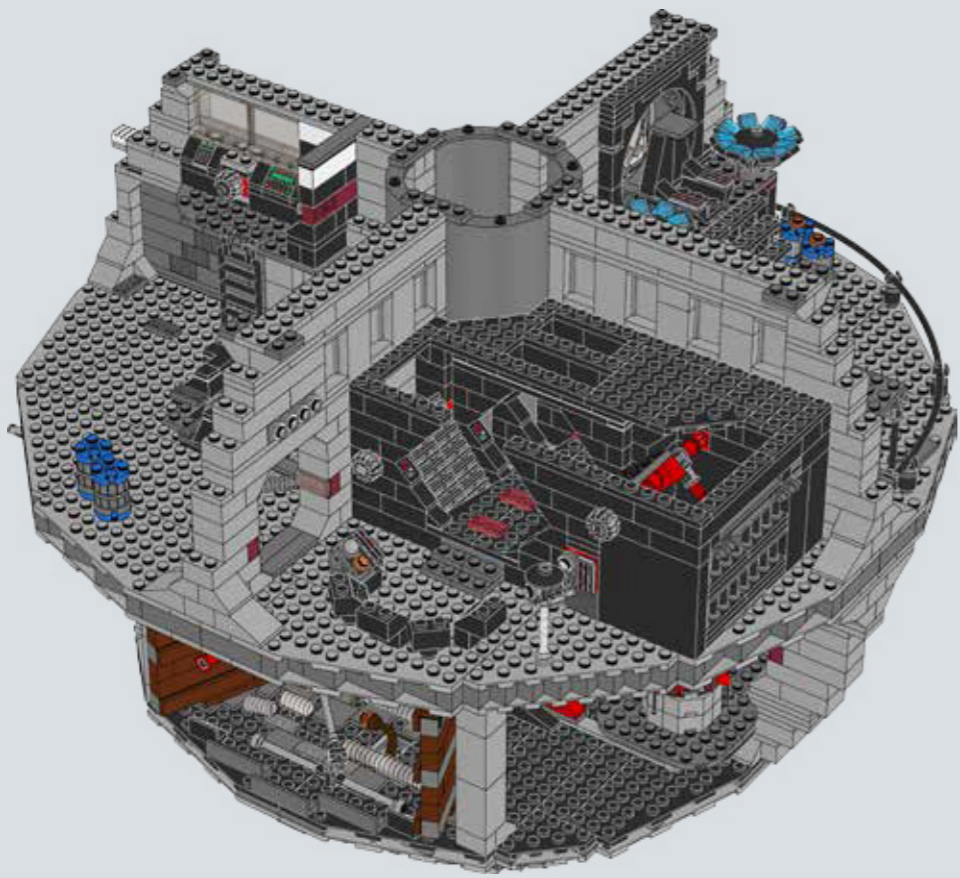

9

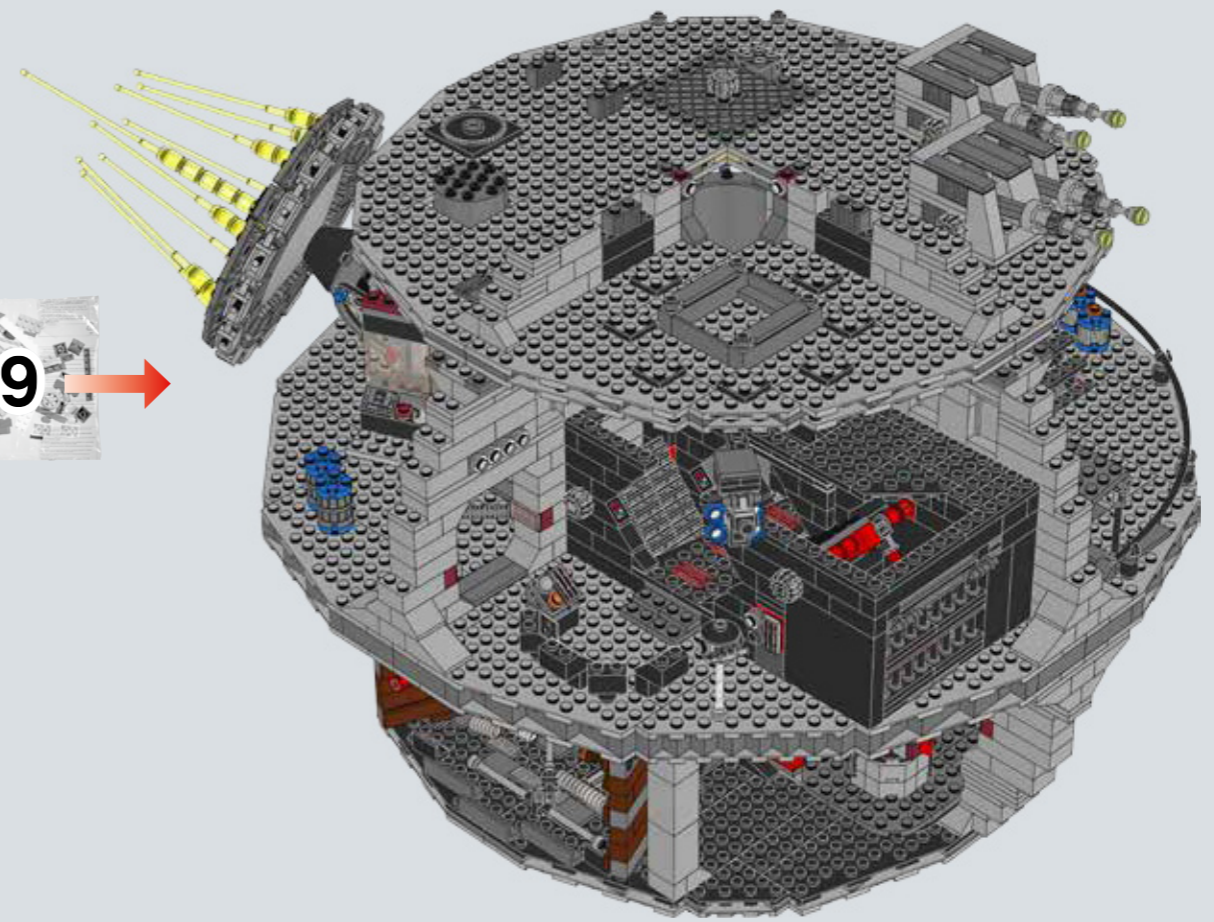

8

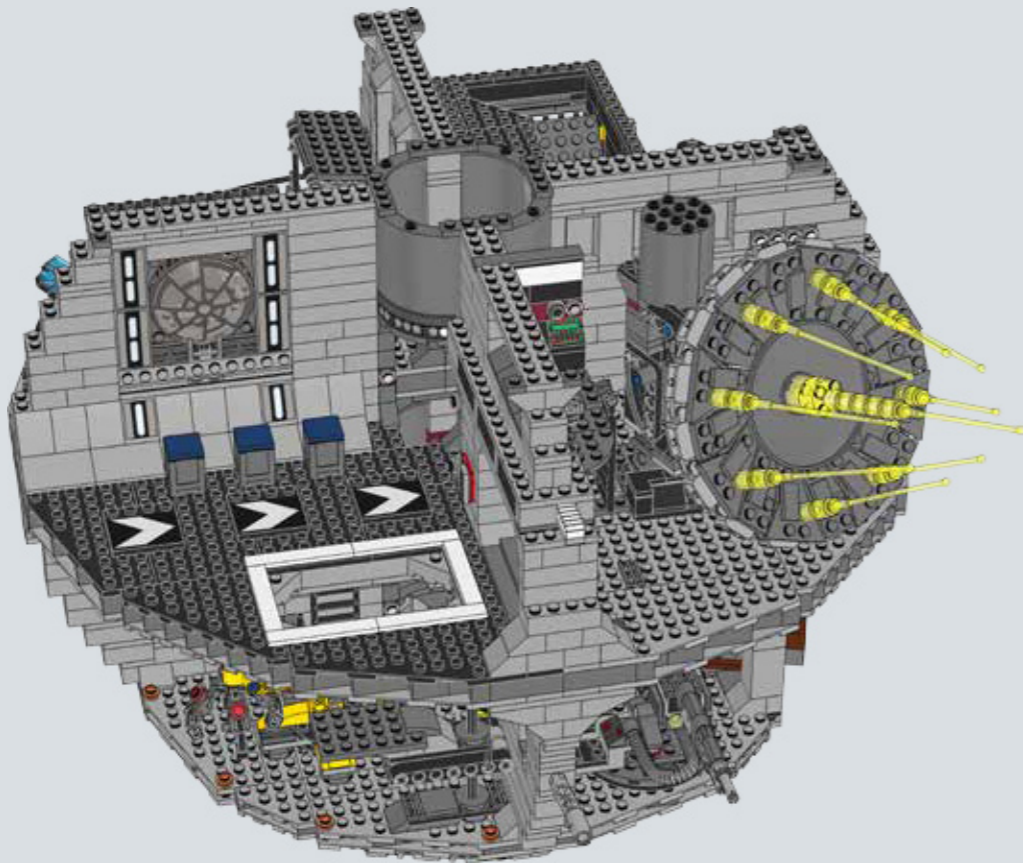

10

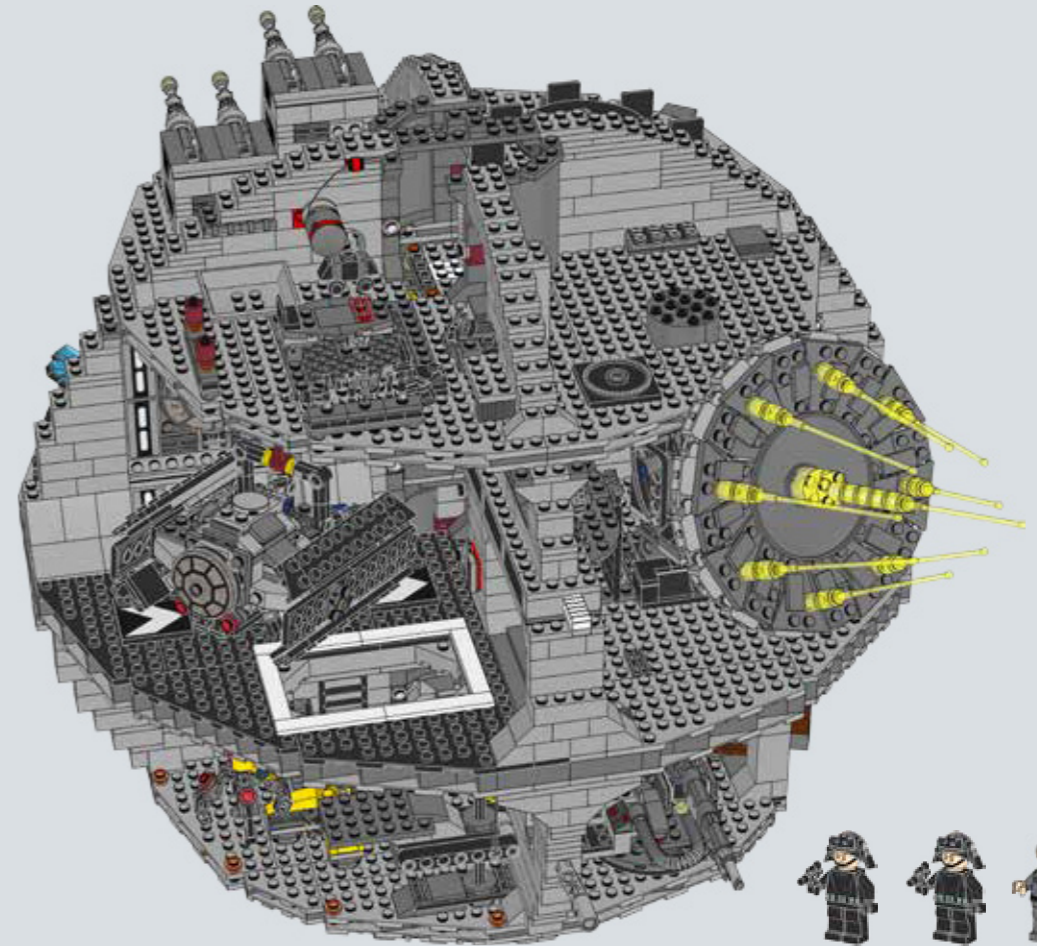



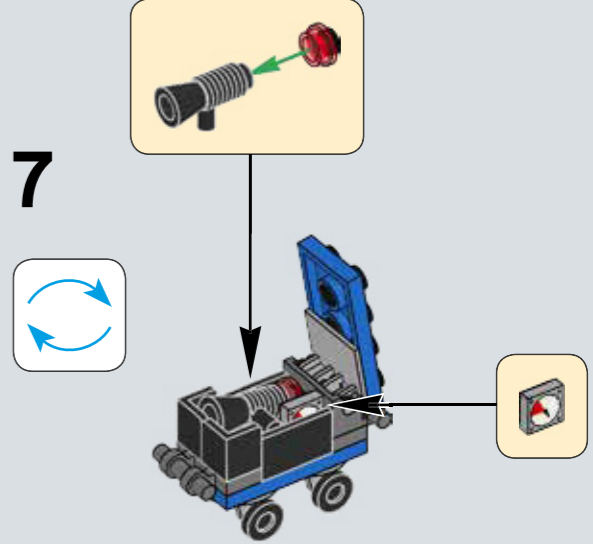
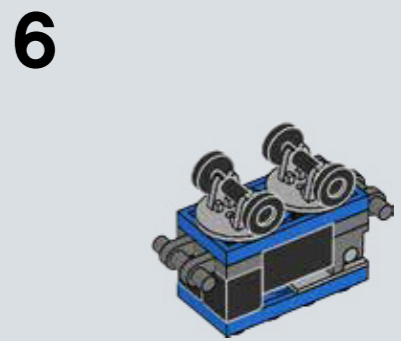
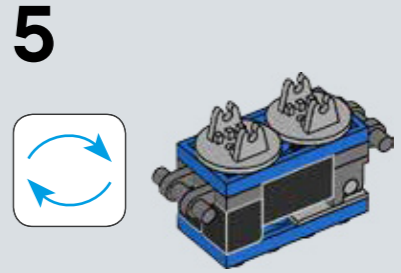
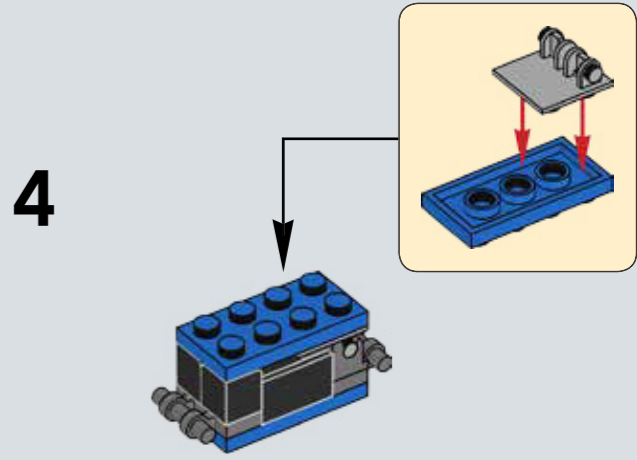
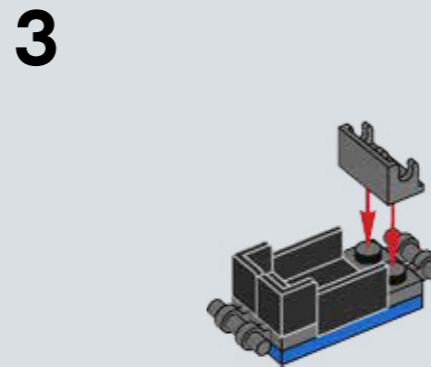
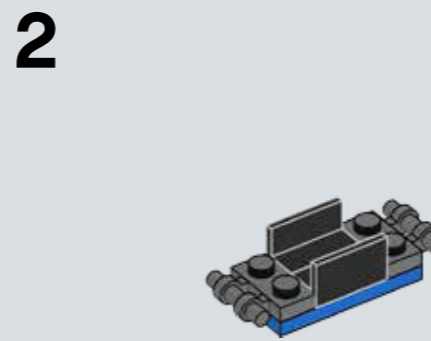
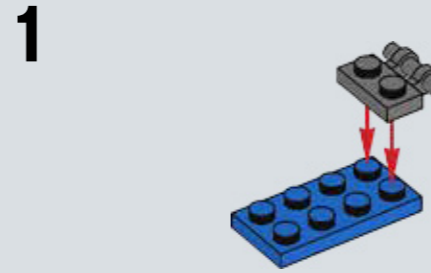
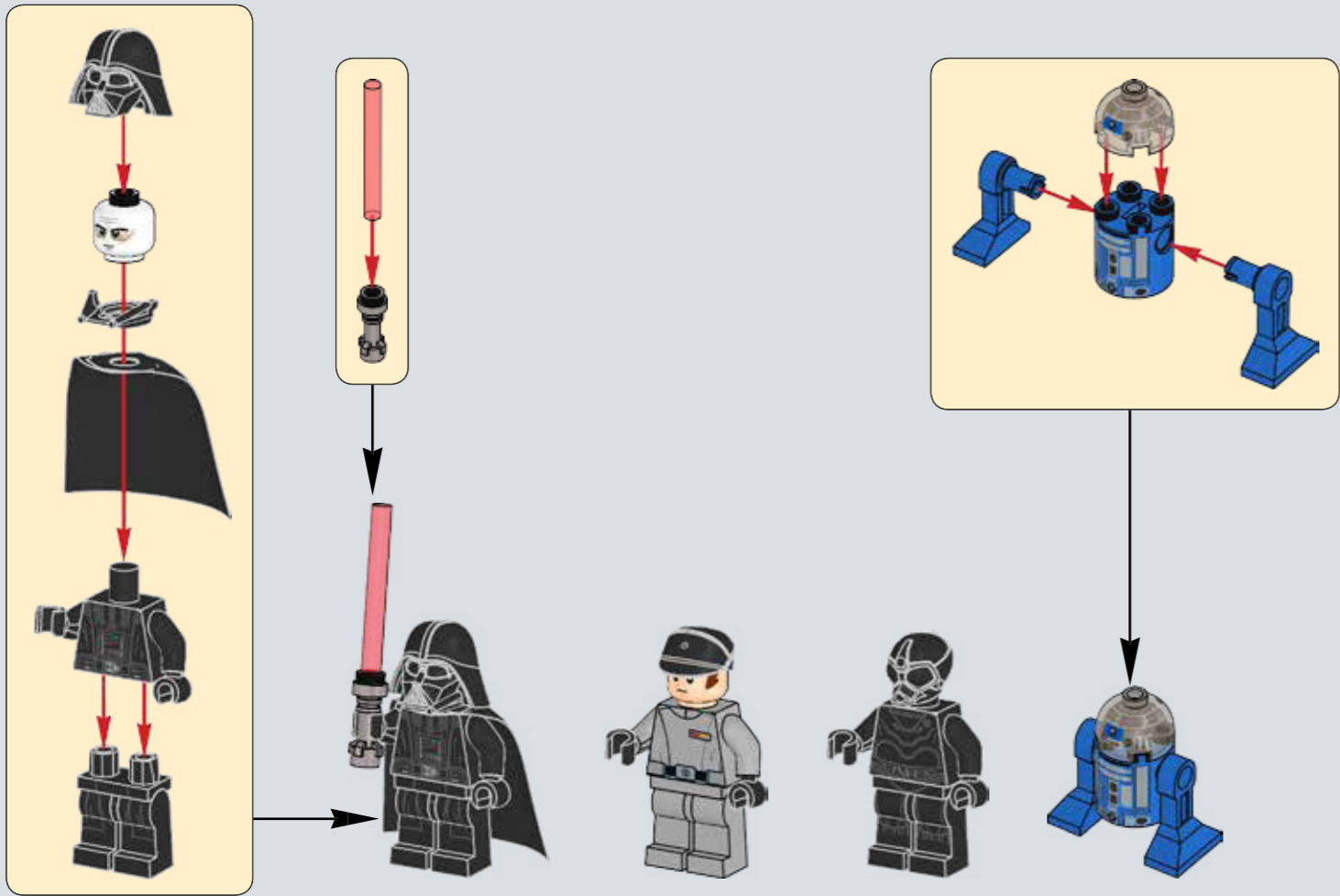
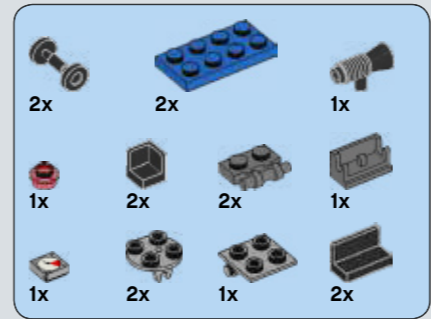
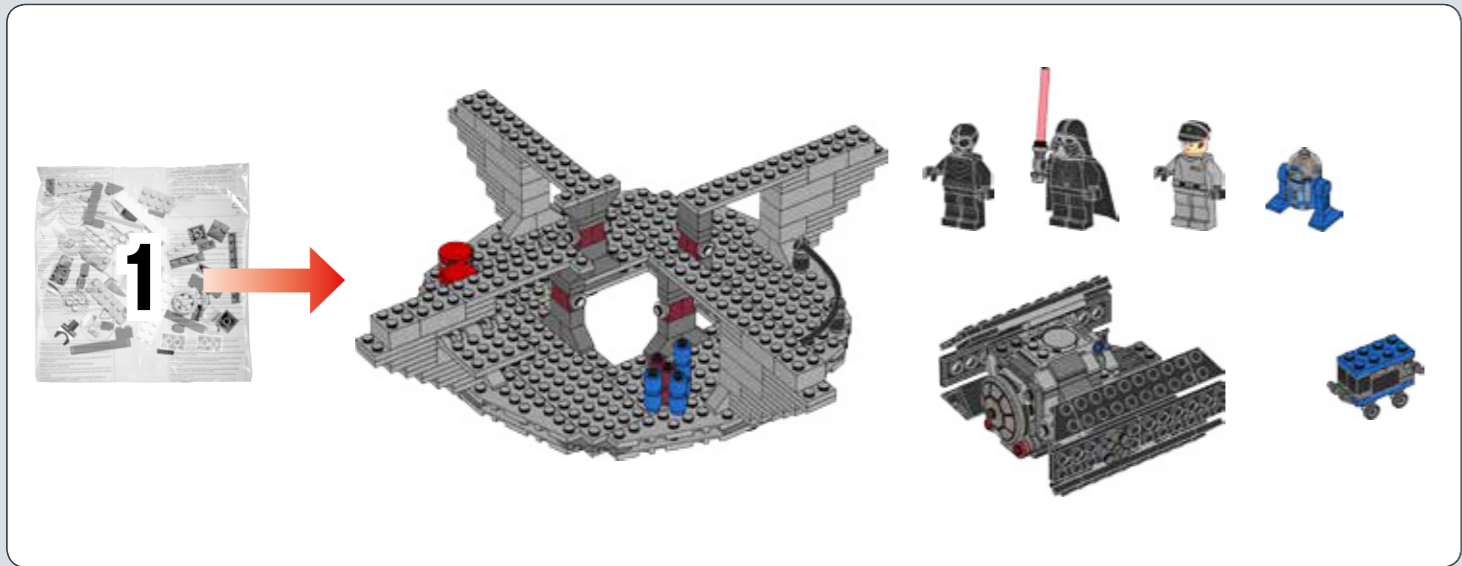

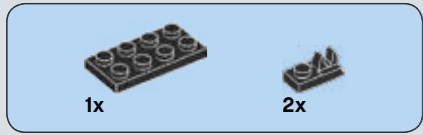
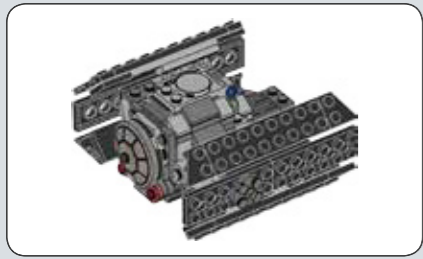

1

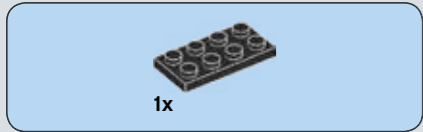
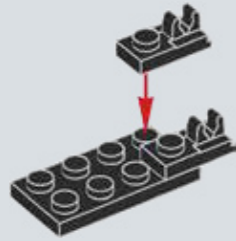

2

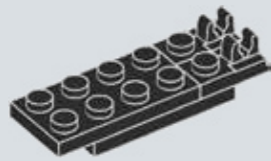

3

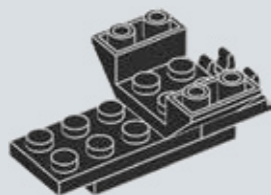

4

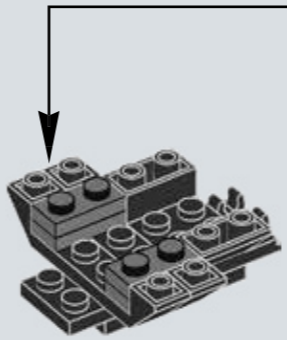
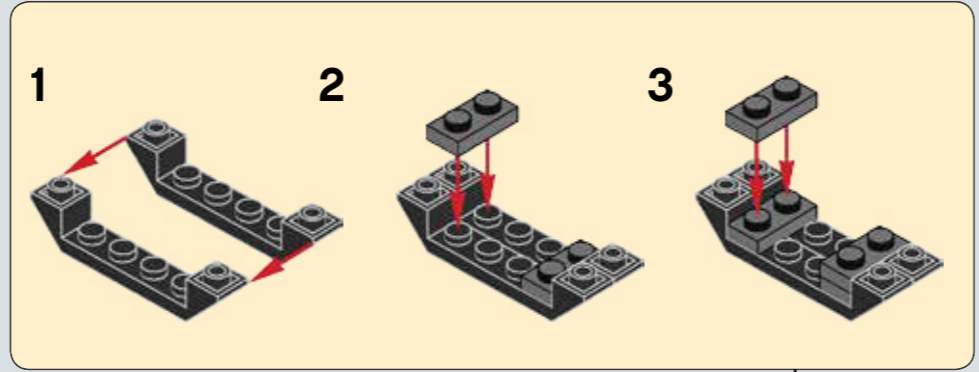

5

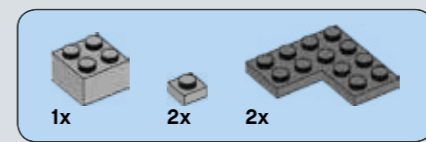
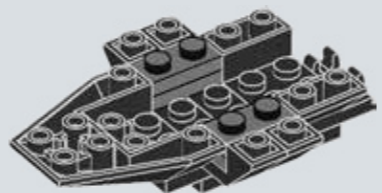

6

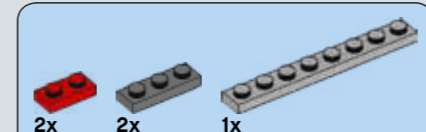
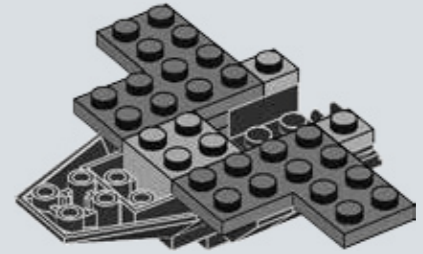

7

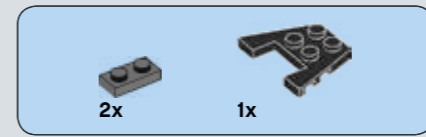
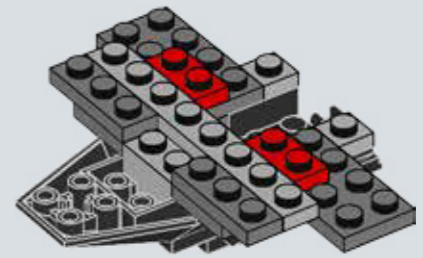

8

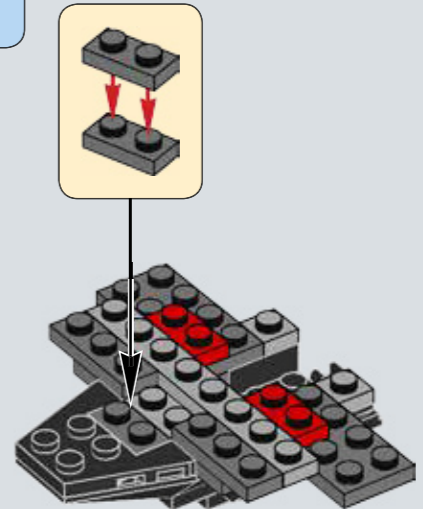

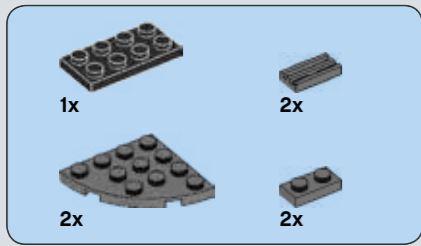

9

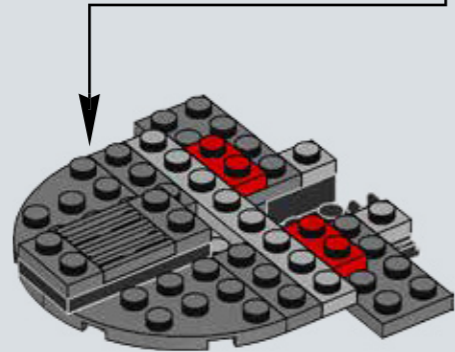
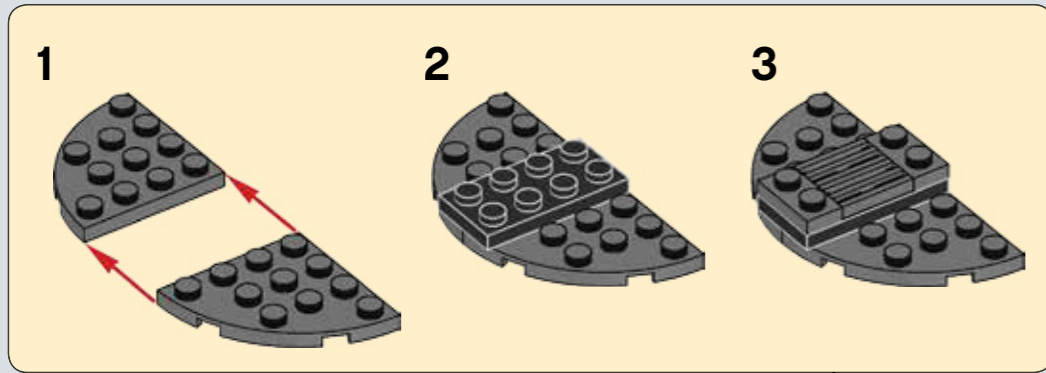

10

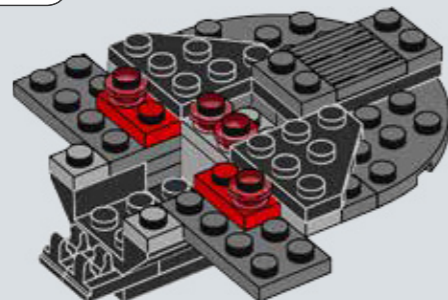
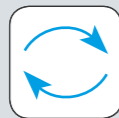

11

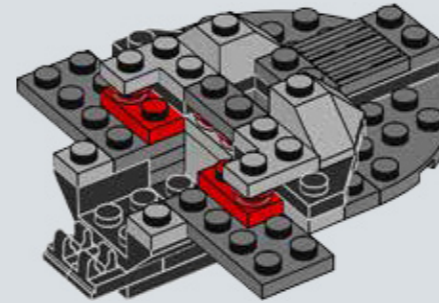

12

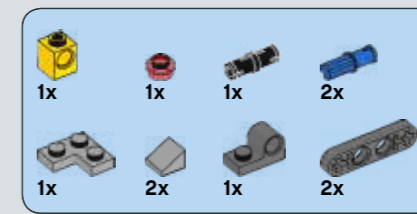
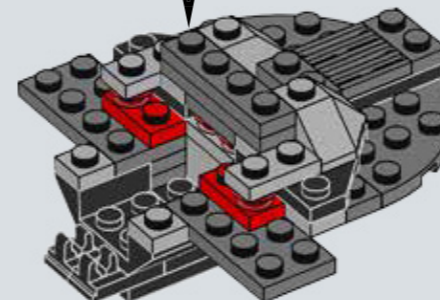
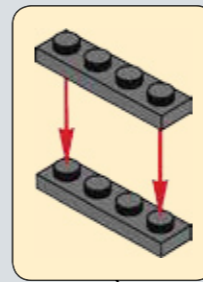

13

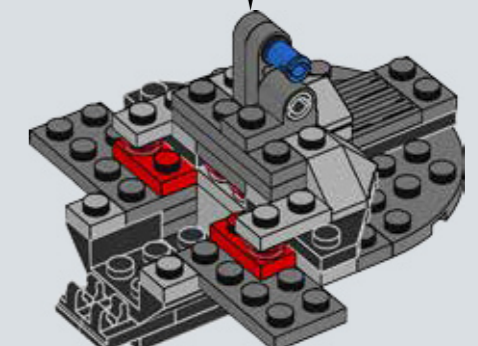
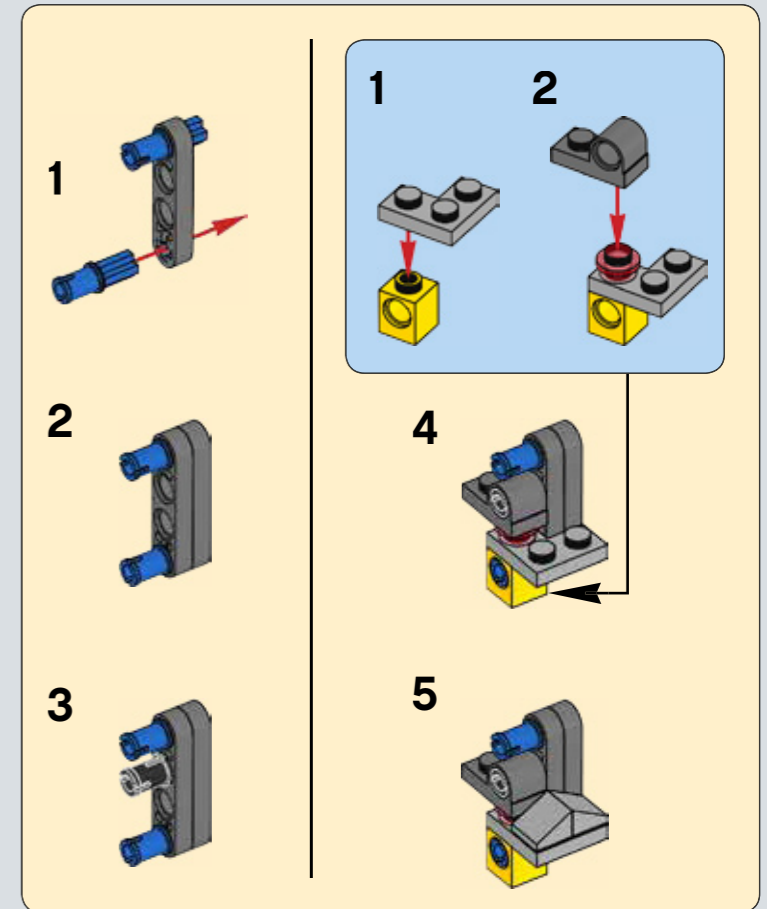



14

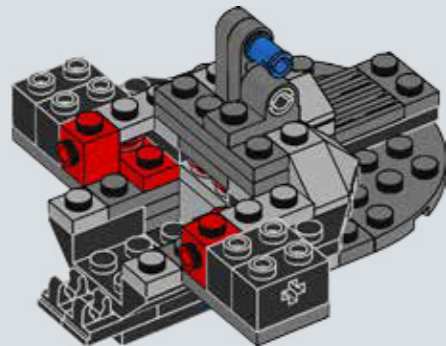

15

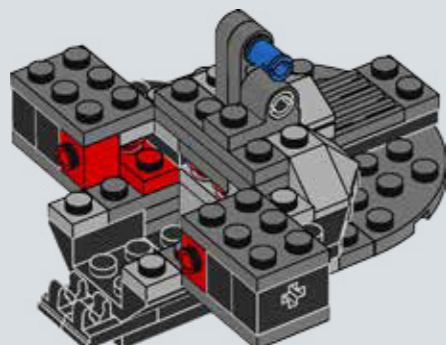

16

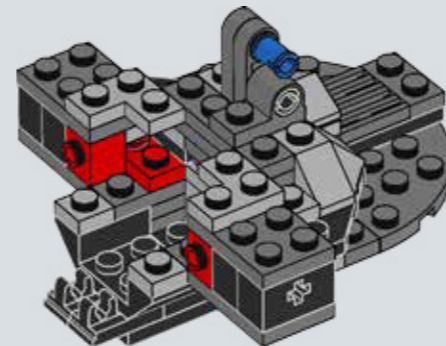

17

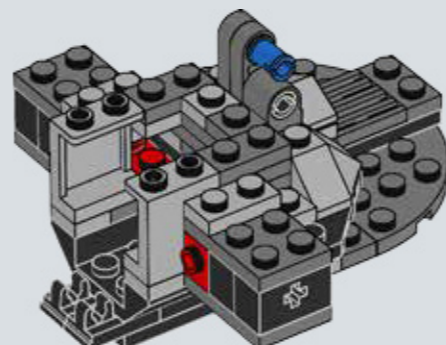

18

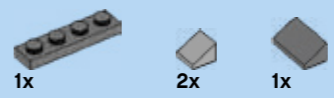
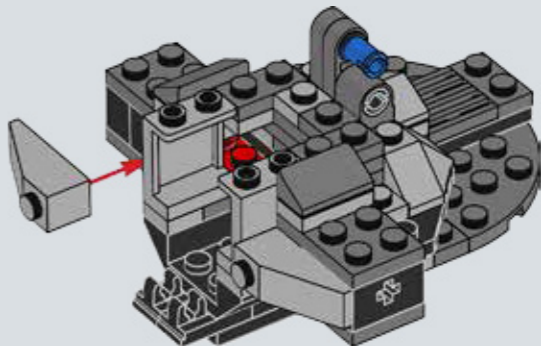

19

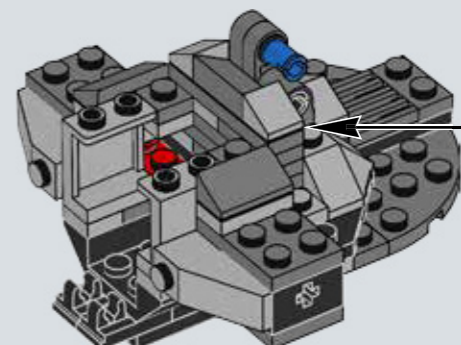
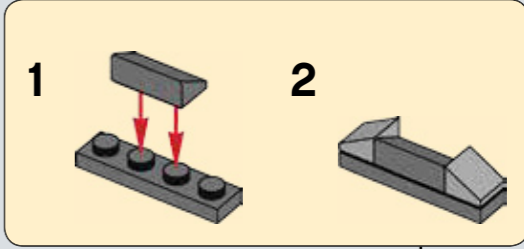

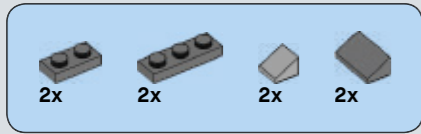

# 20

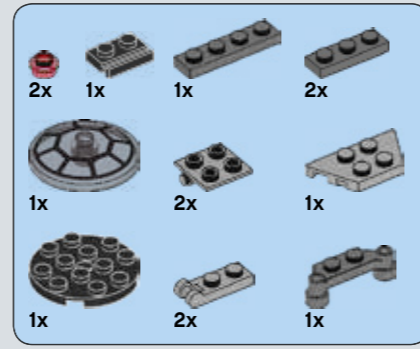
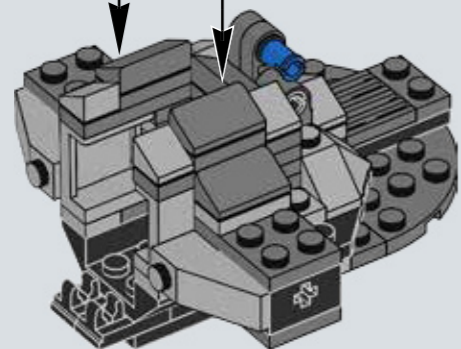
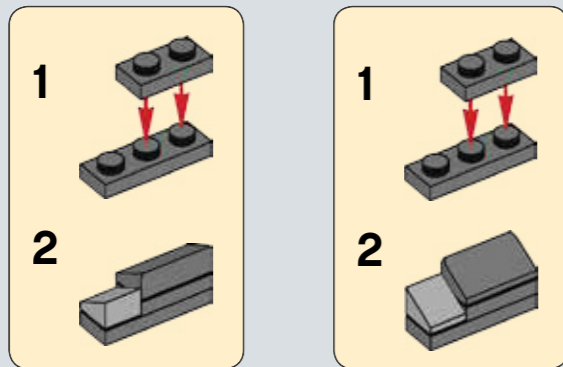

# 21

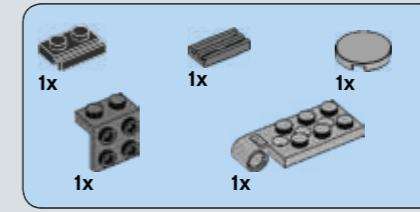
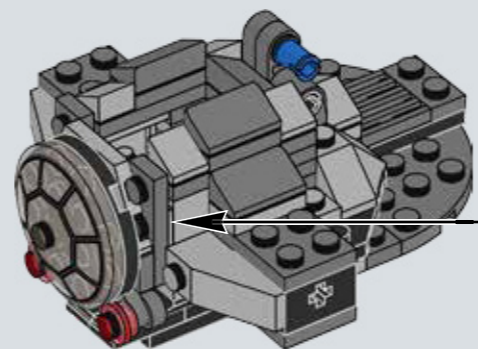
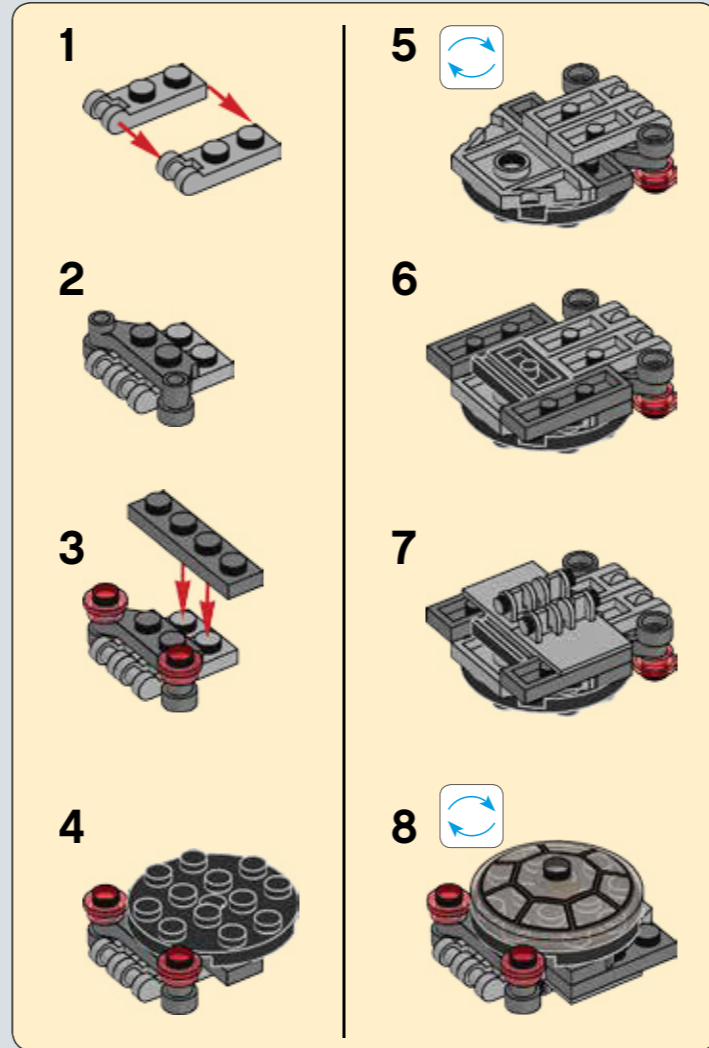

# 22

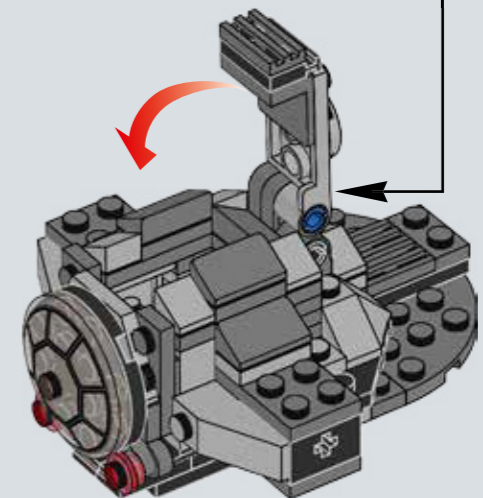
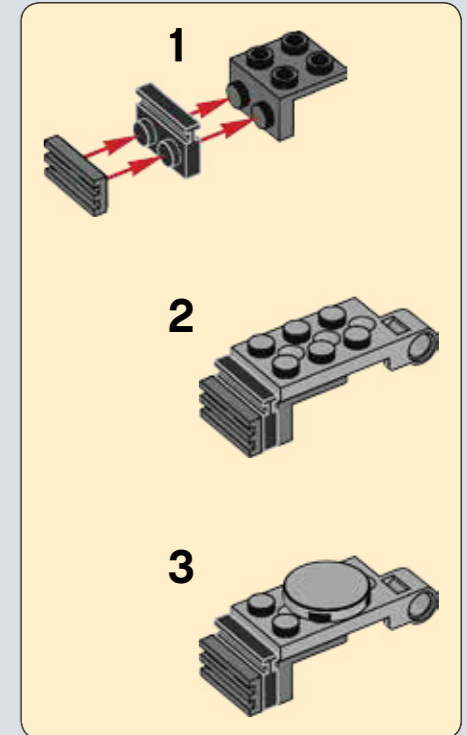

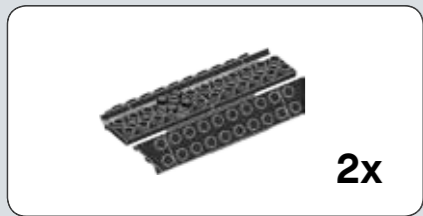

23

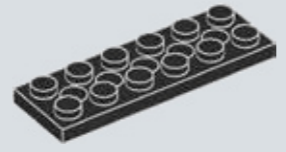

24

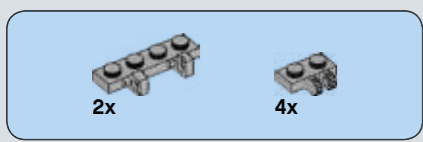
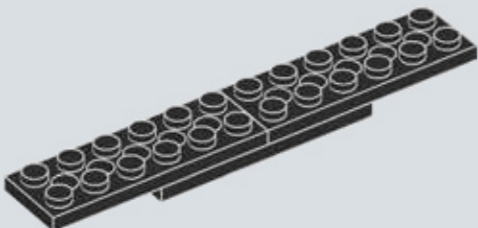

25

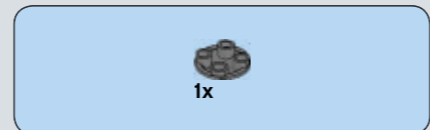
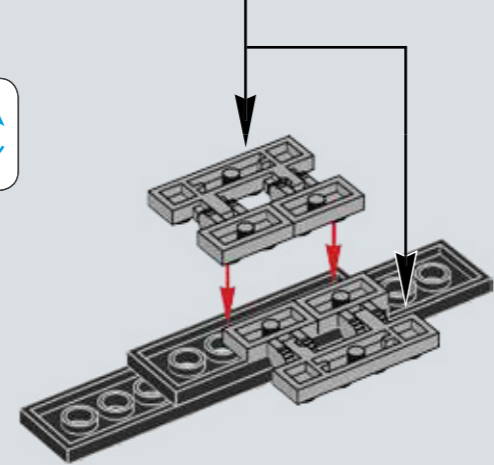
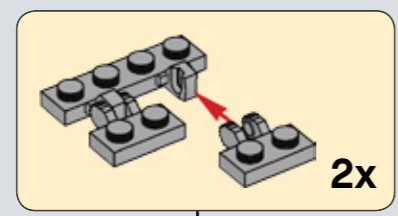
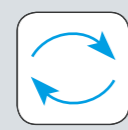

26

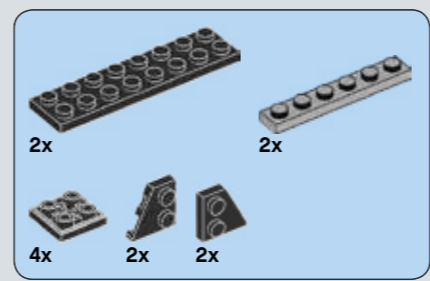
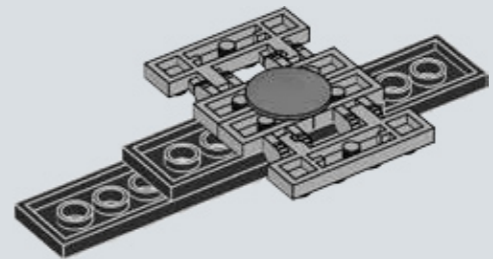

27

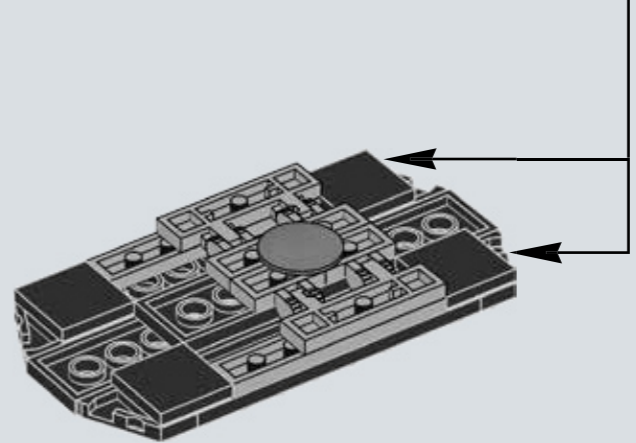
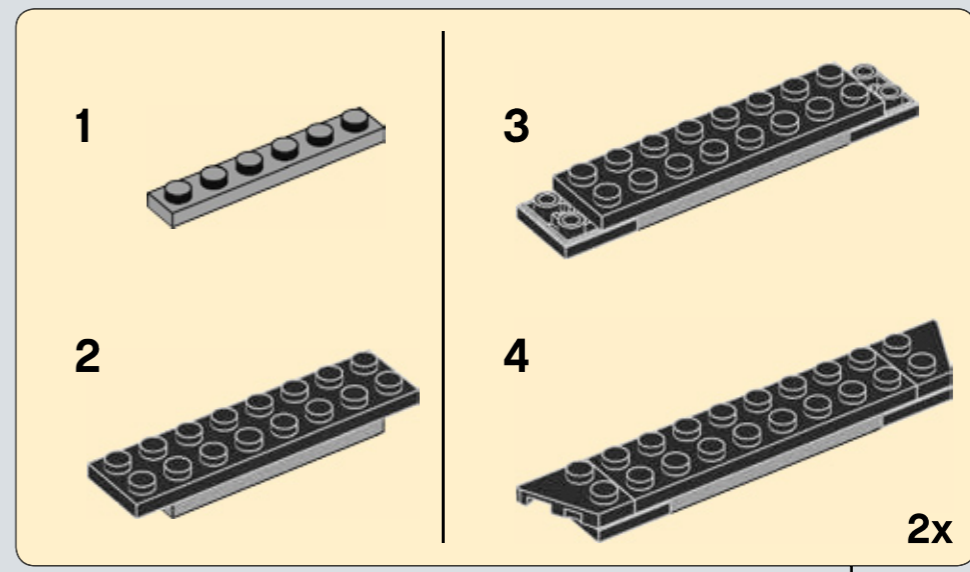

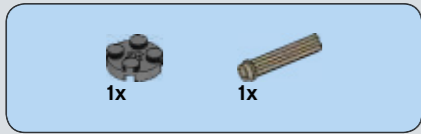

28

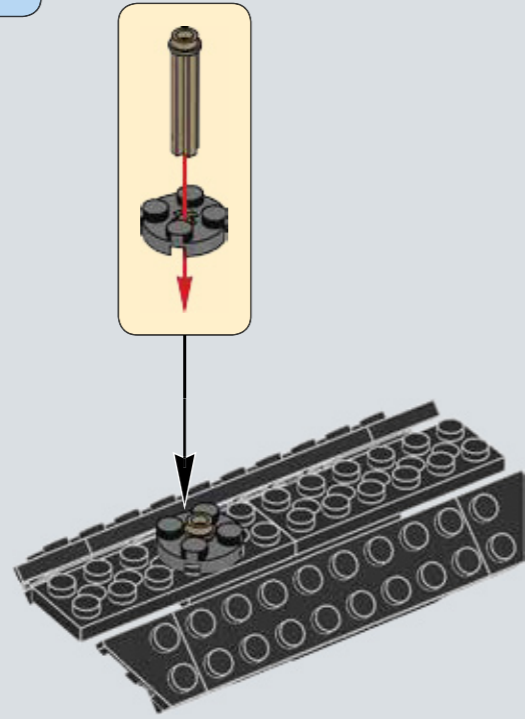

2x

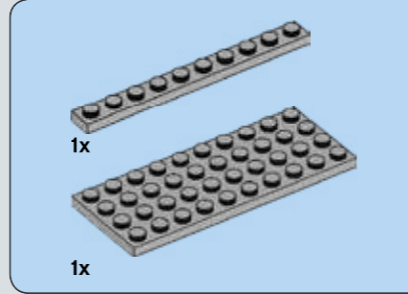
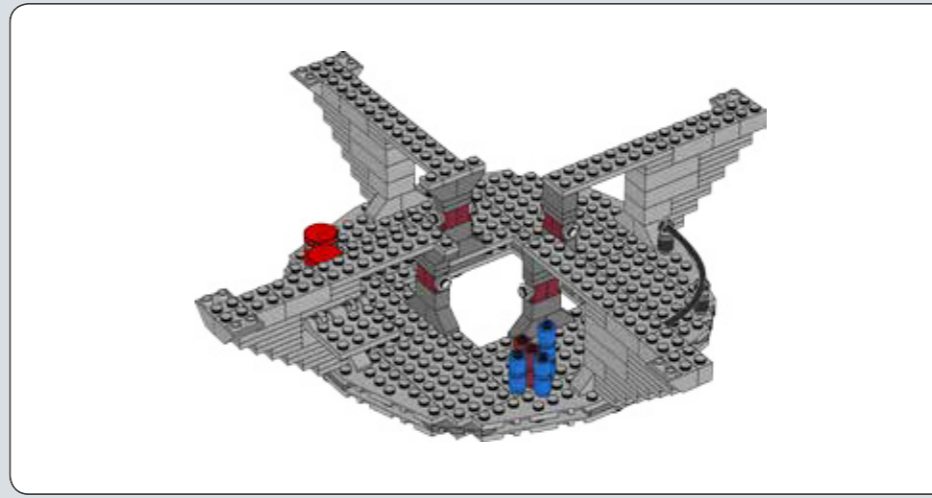

1

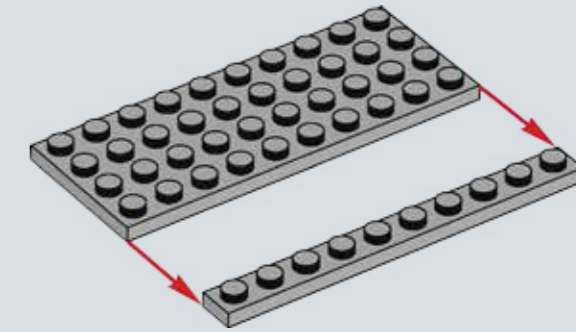

2

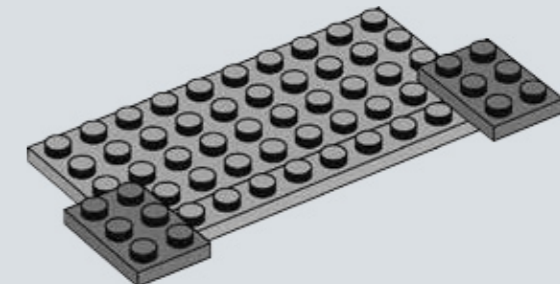

29

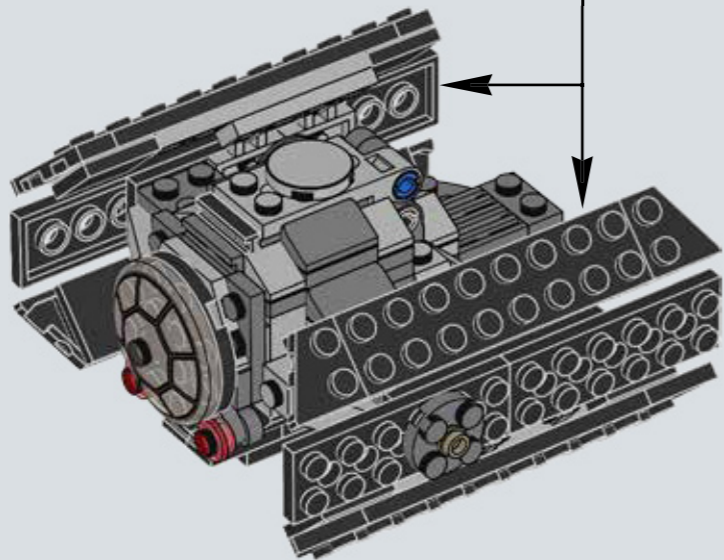

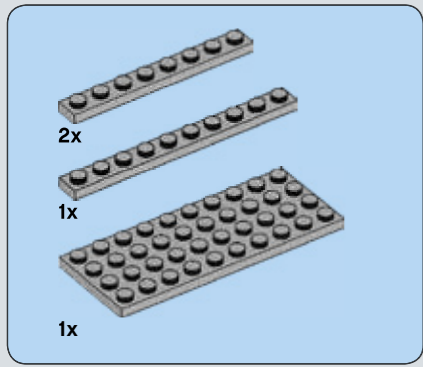

3

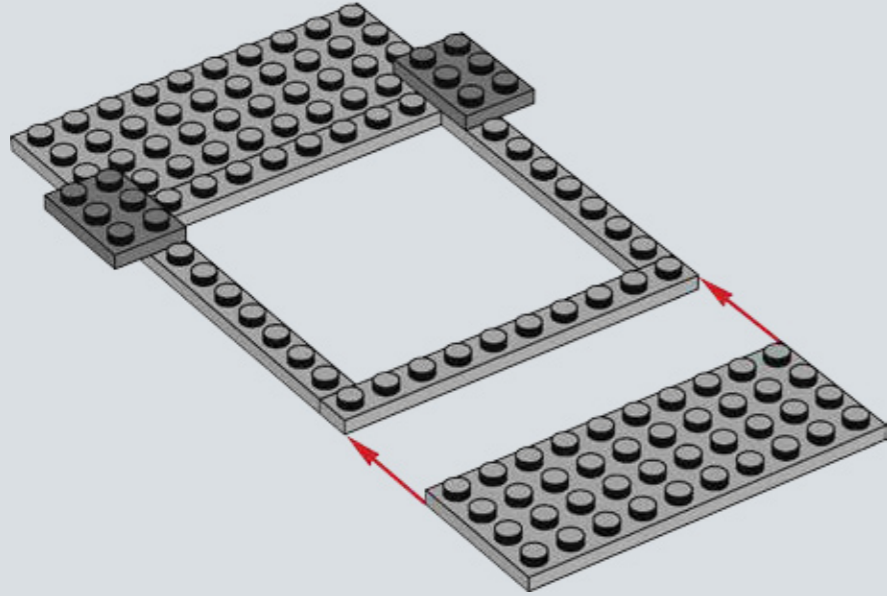

4

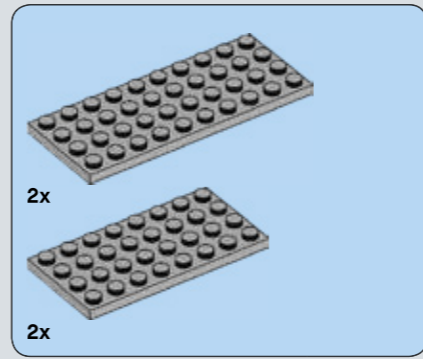
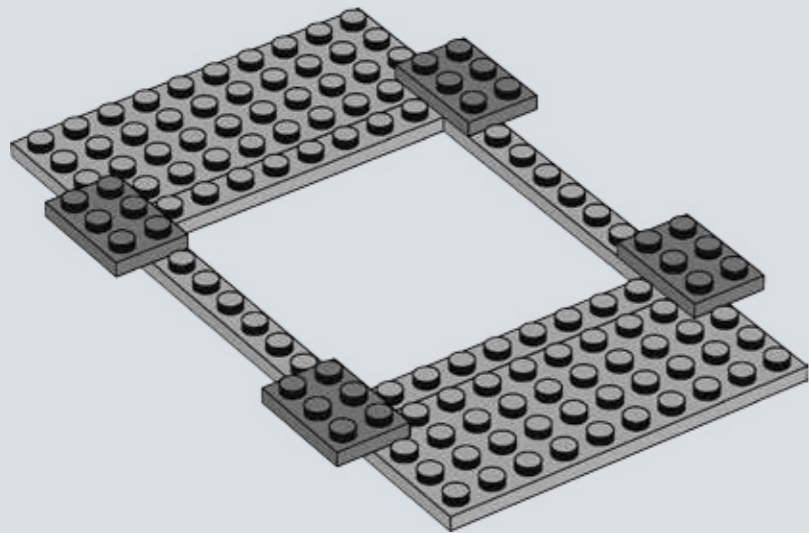

5

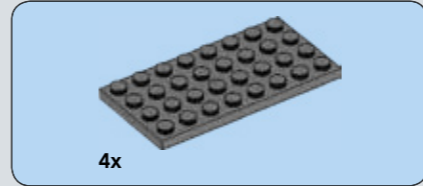
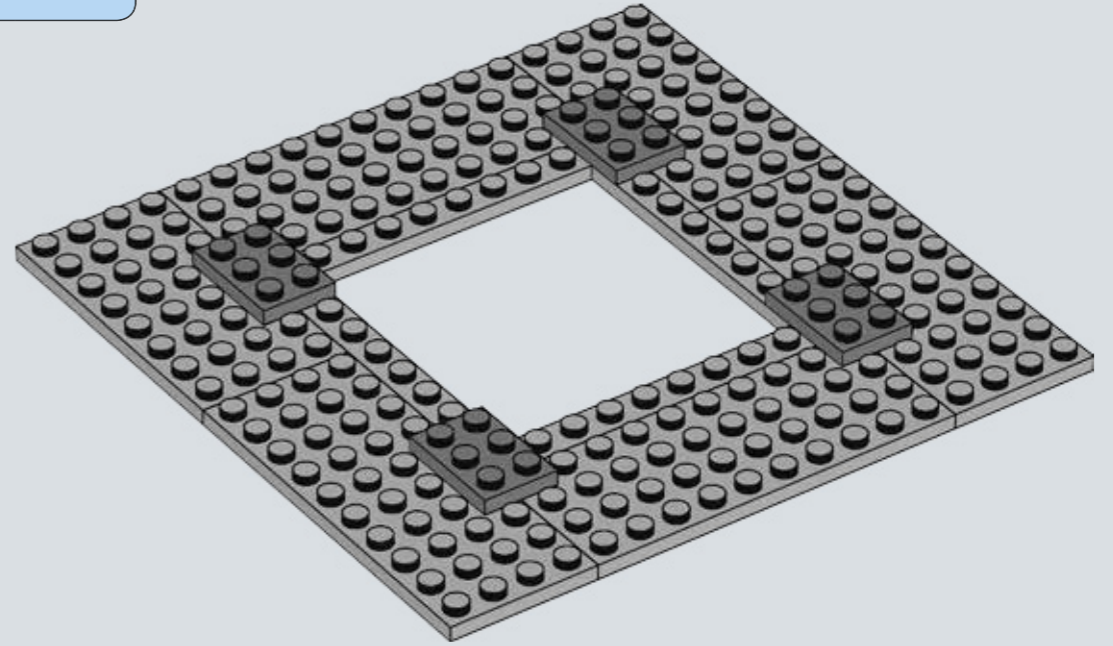

6

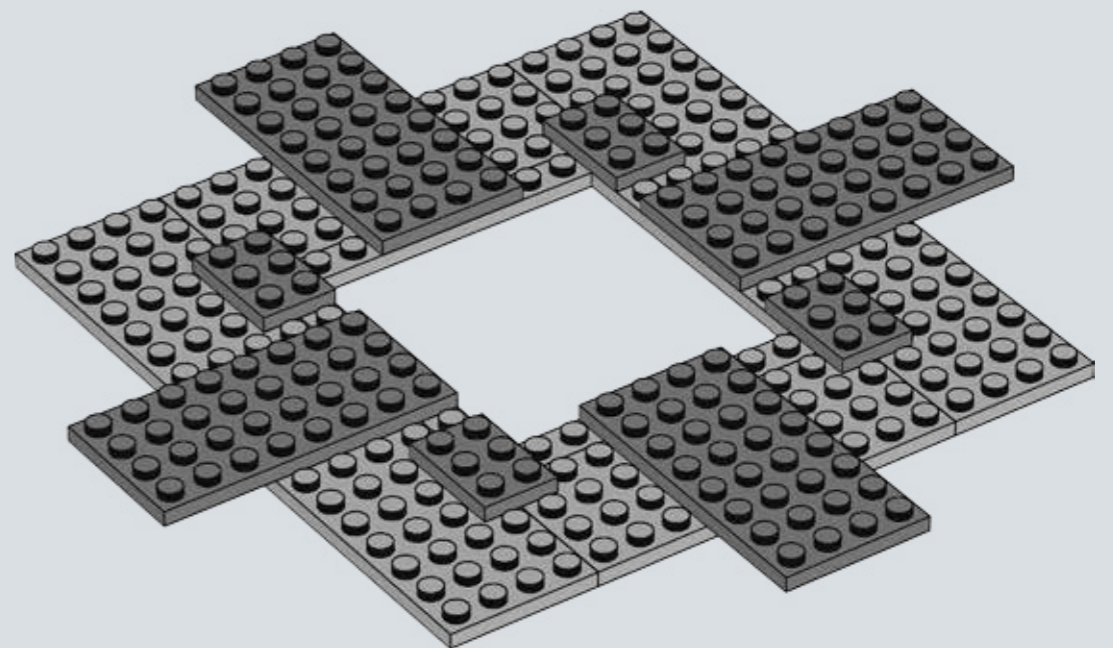



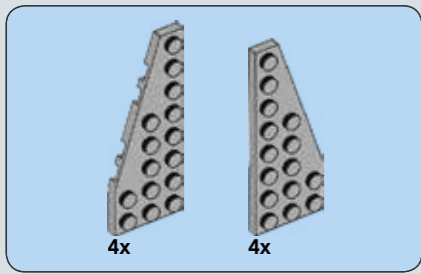

7

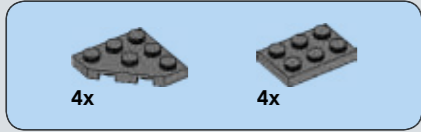
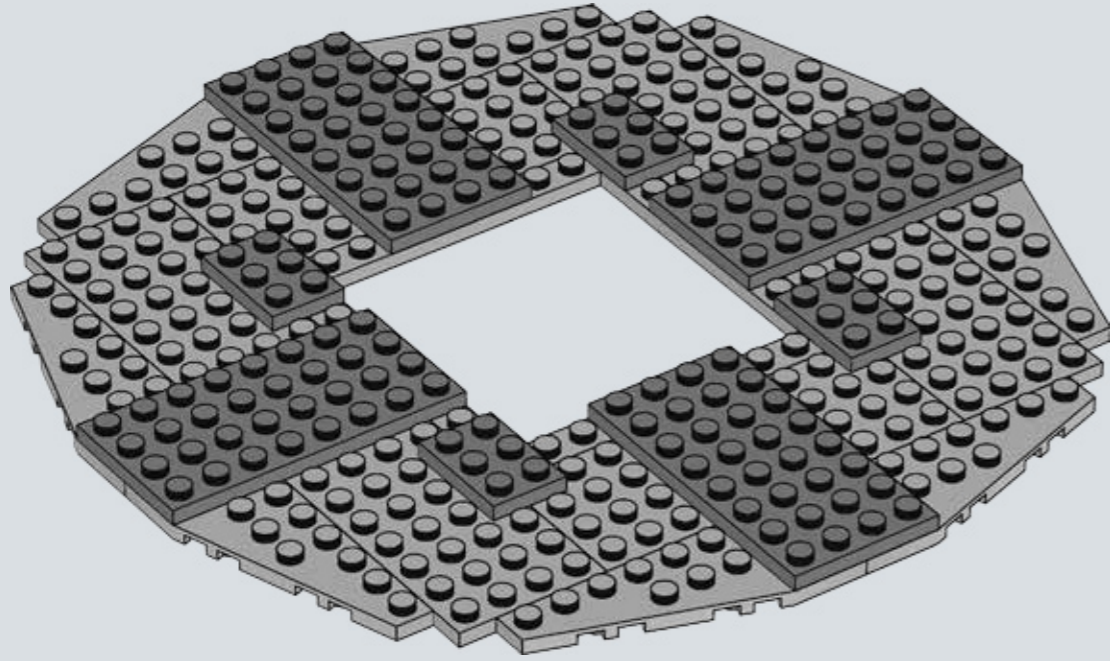

8

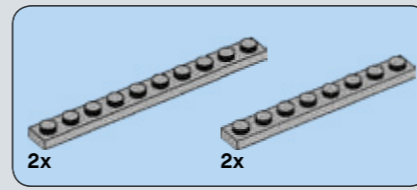
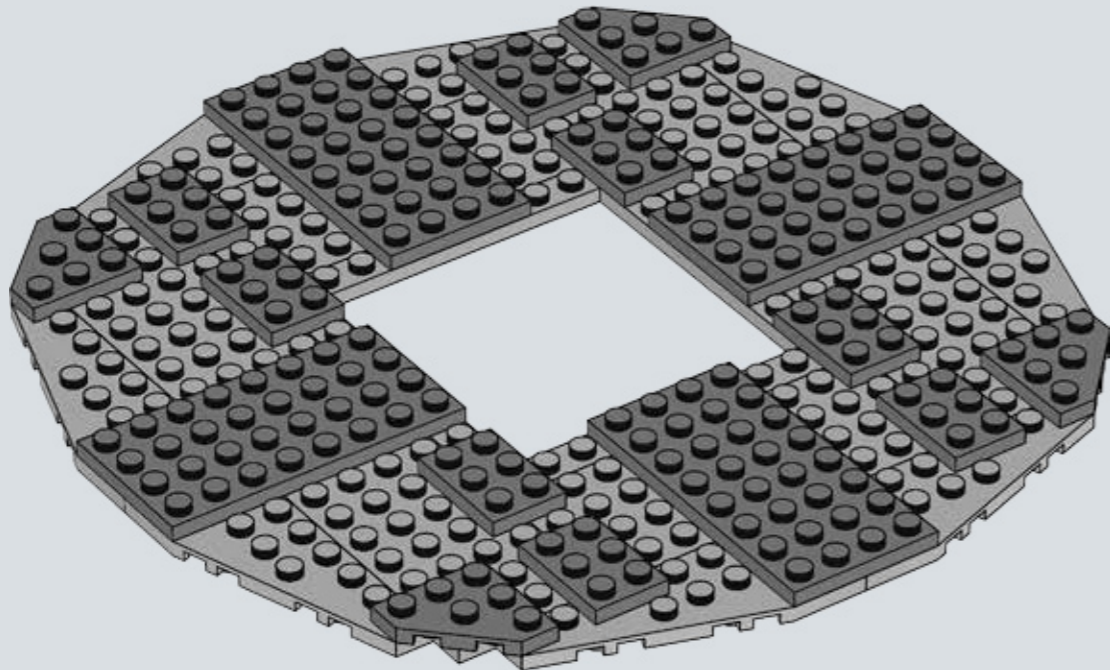

9

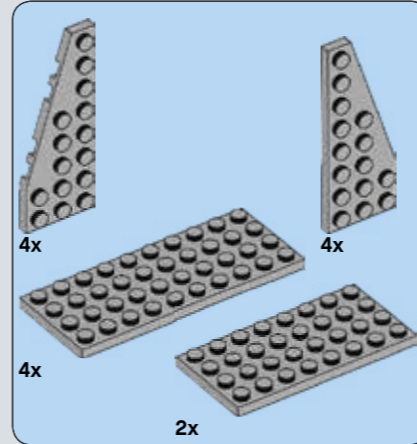
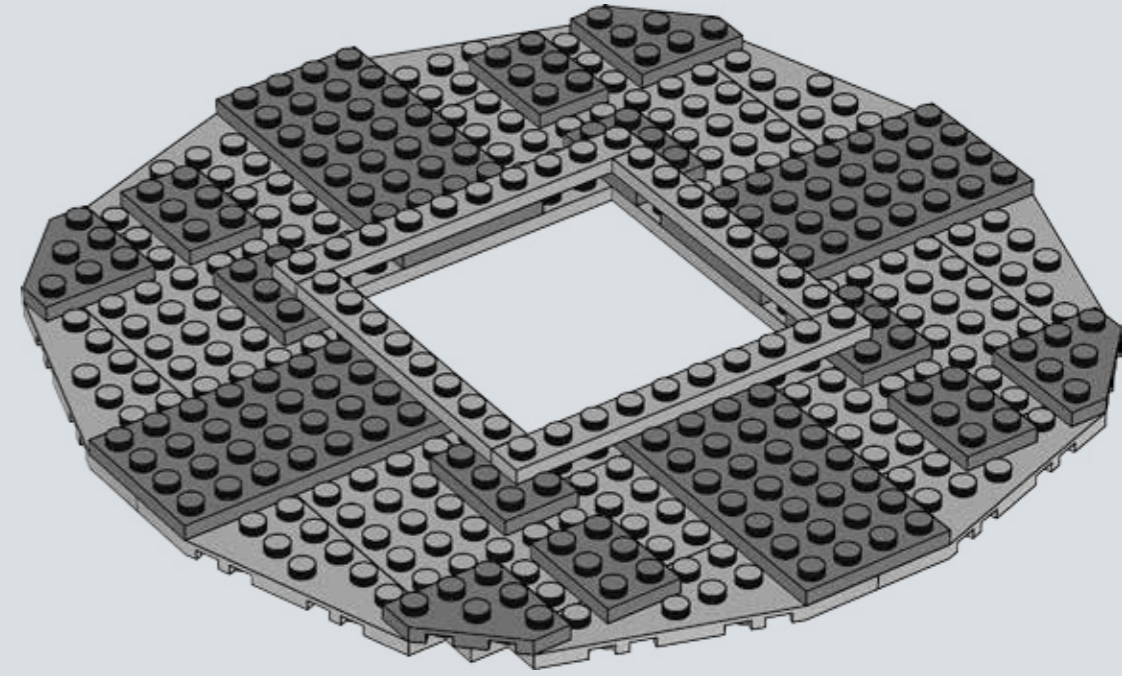

10

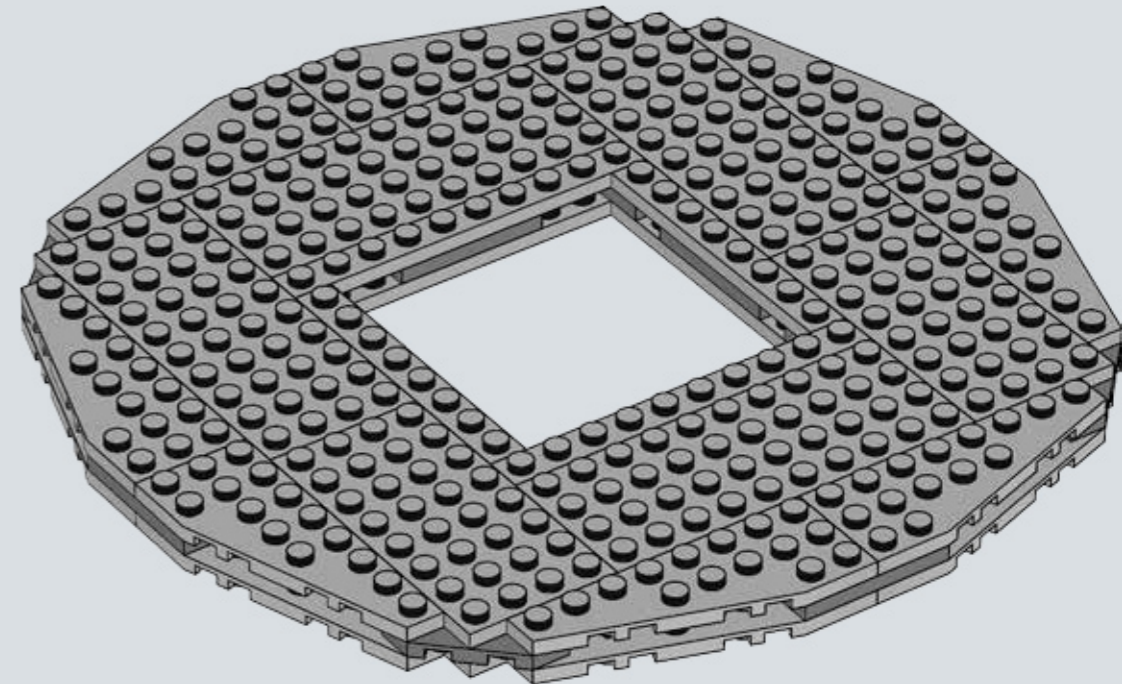

12x

# 11

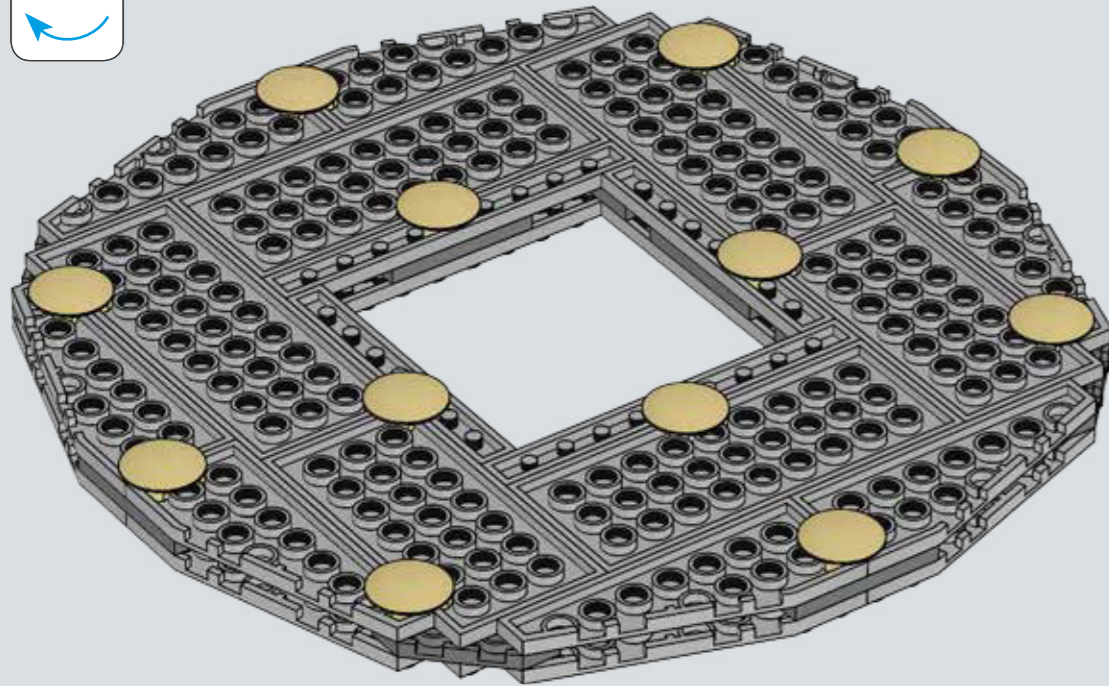
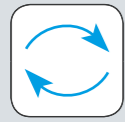

3x 8x 3x 7x 3x 1x

# 12

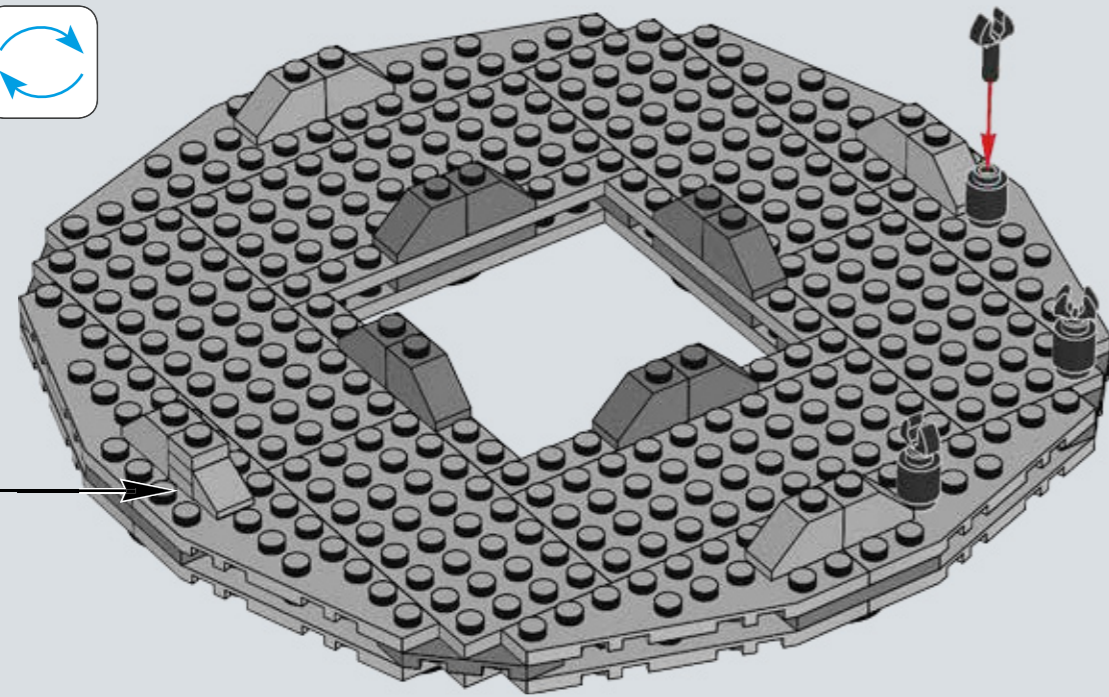
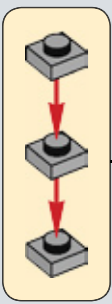
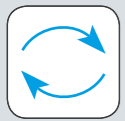

8x 8x 4x 8x

# 13

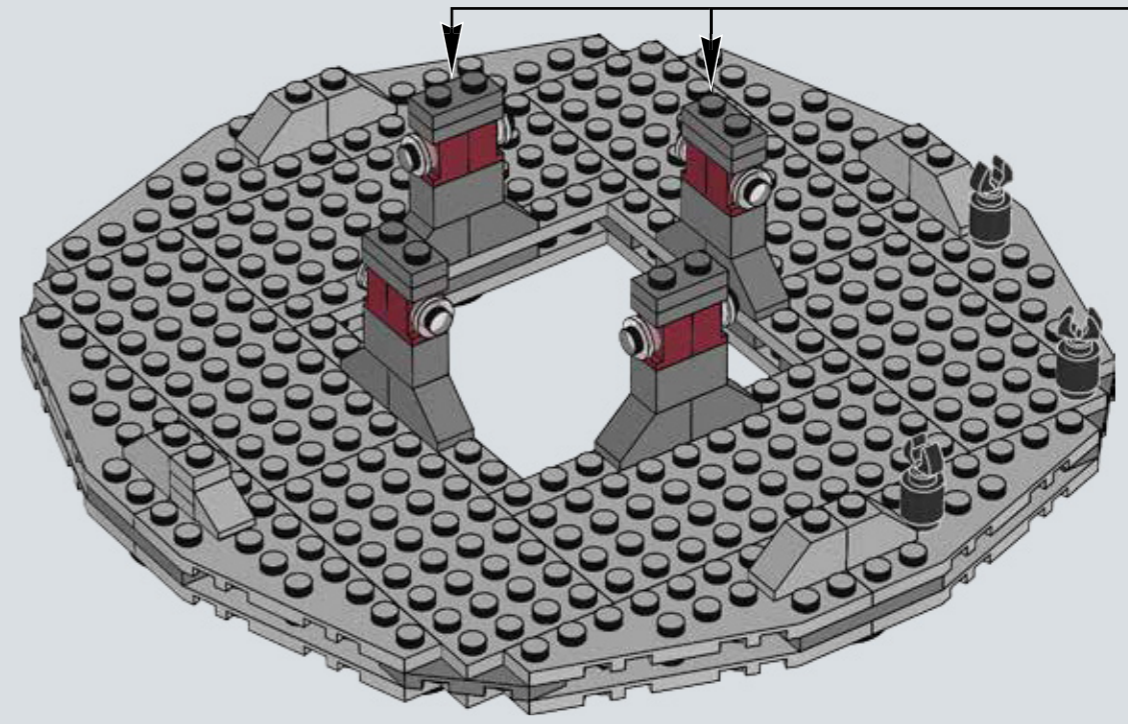
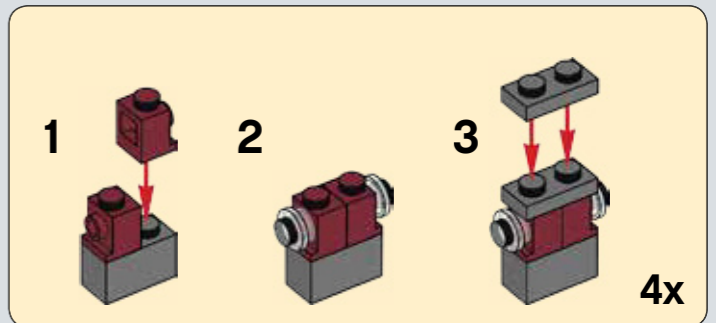

2x 4x

# 14

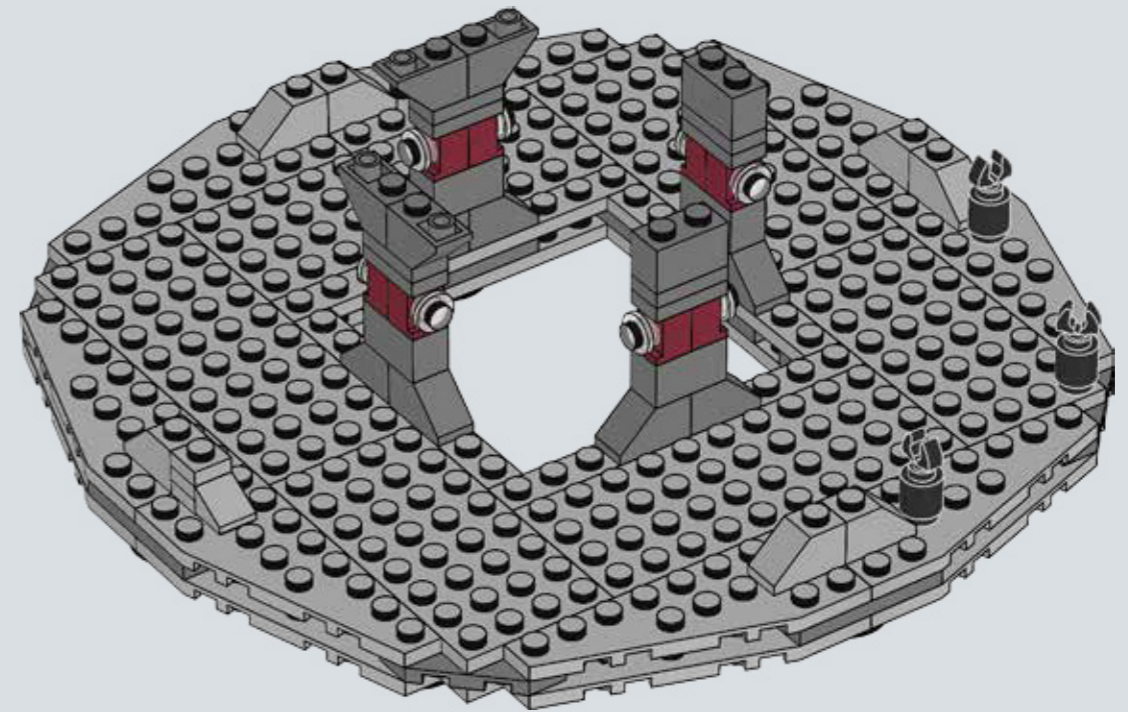

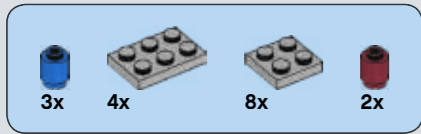

15

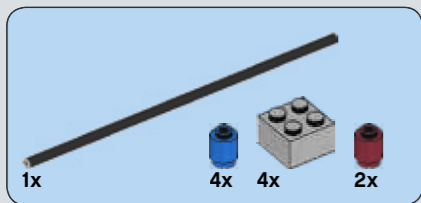
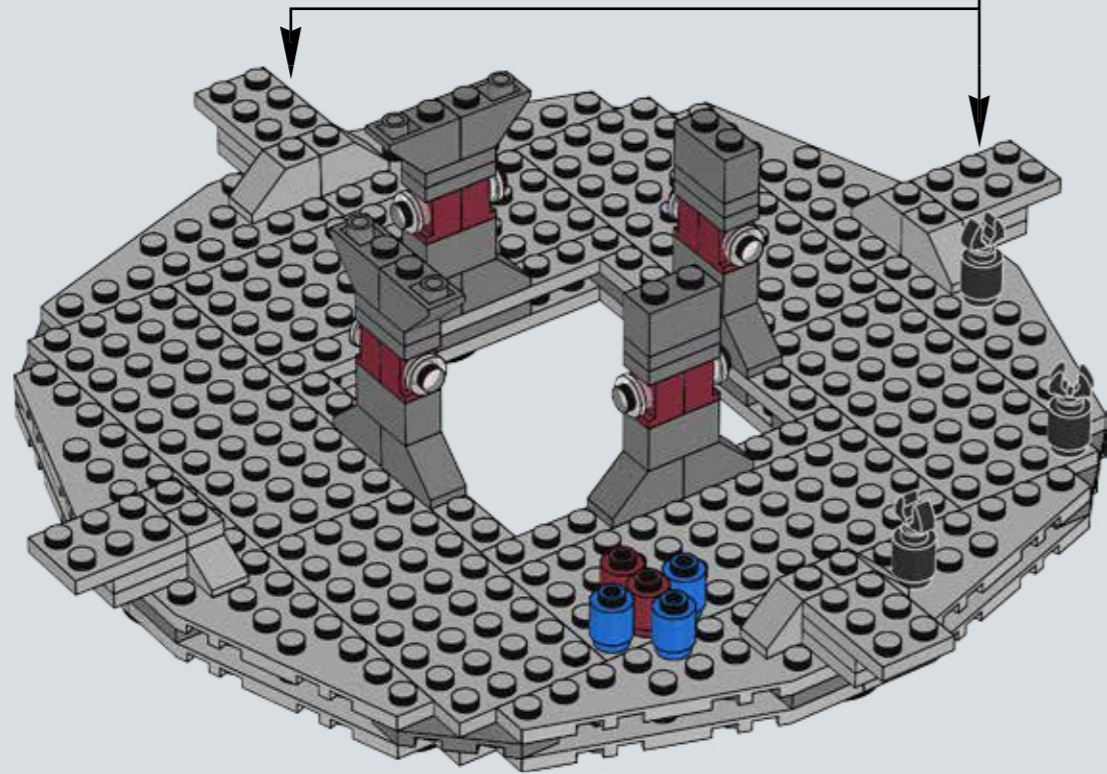
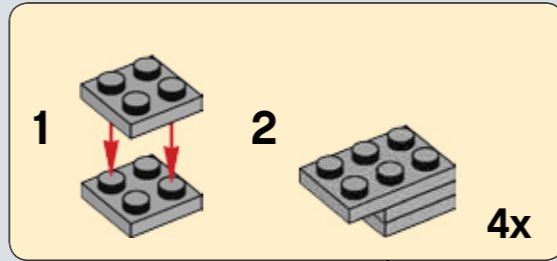

16

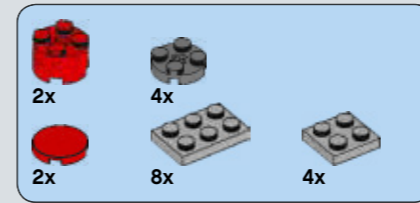
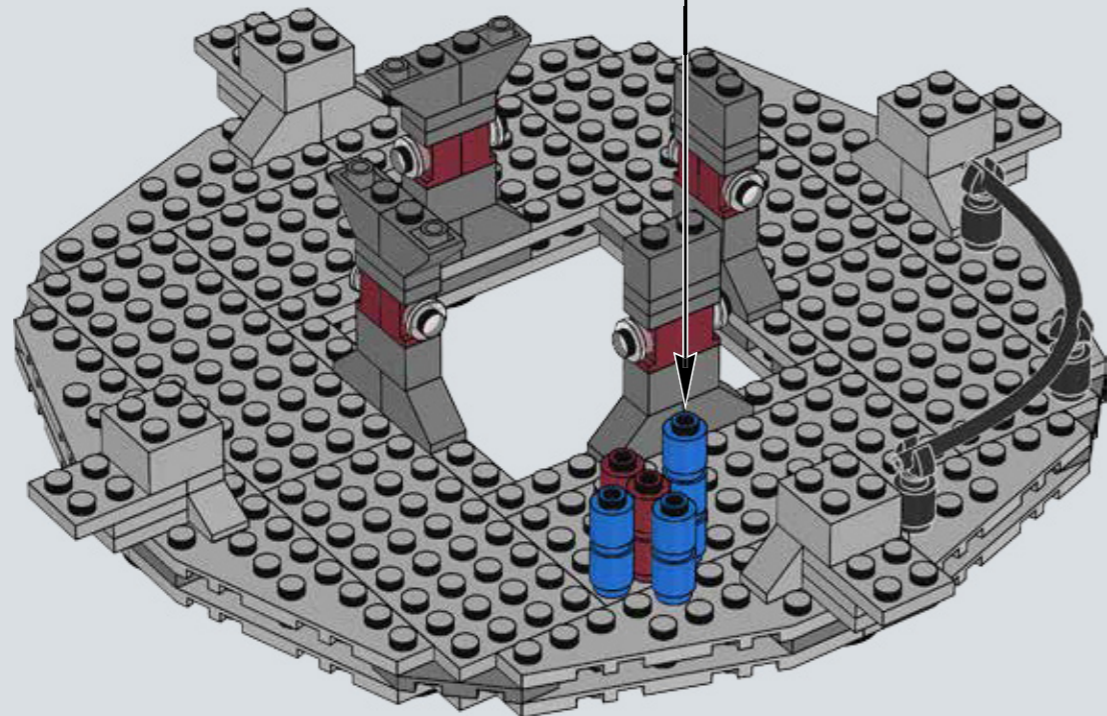
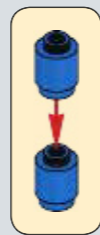

17

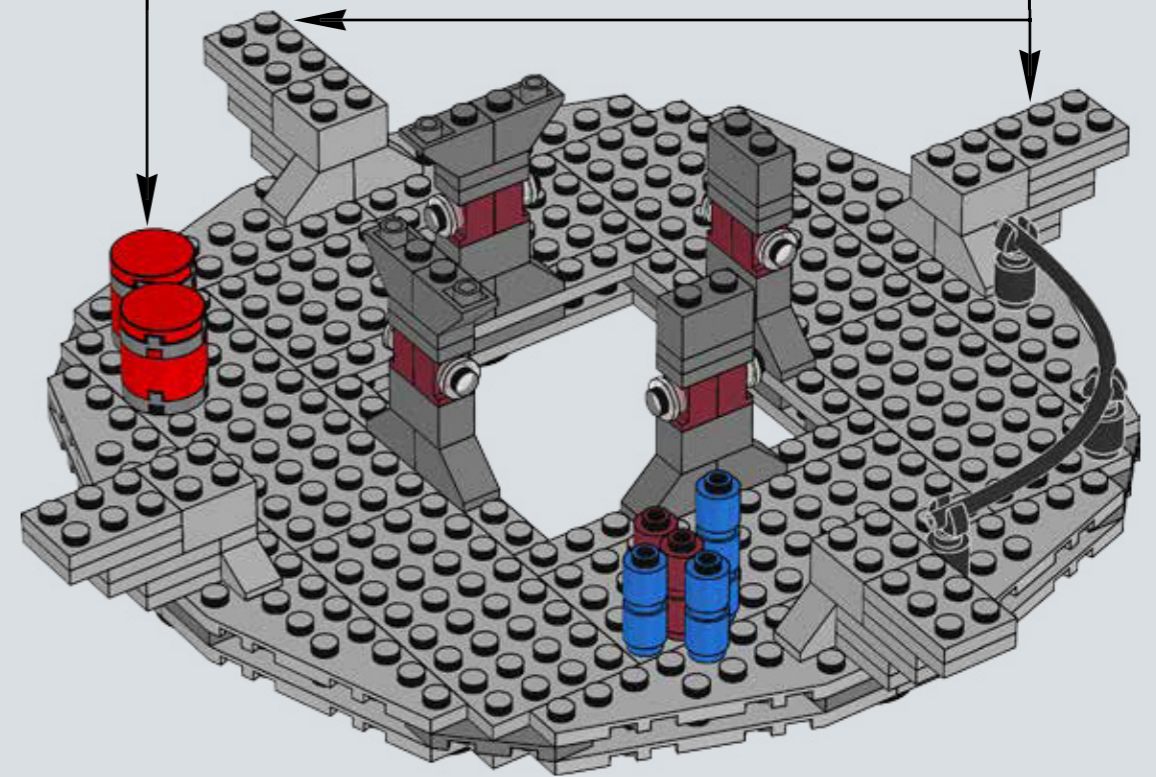
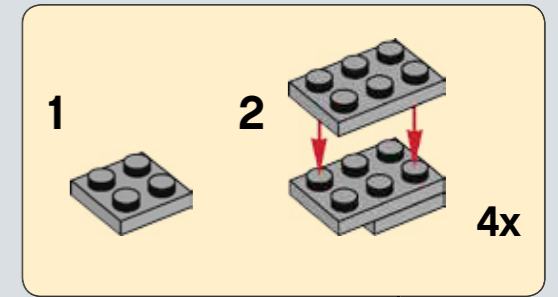
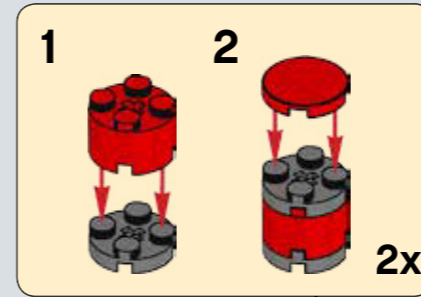

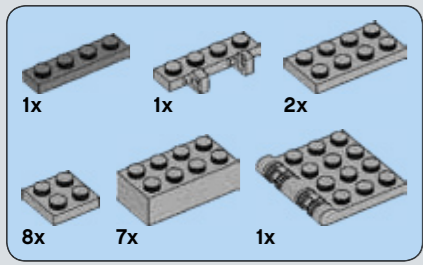

# 18

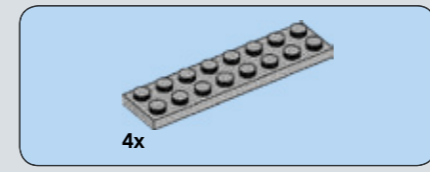
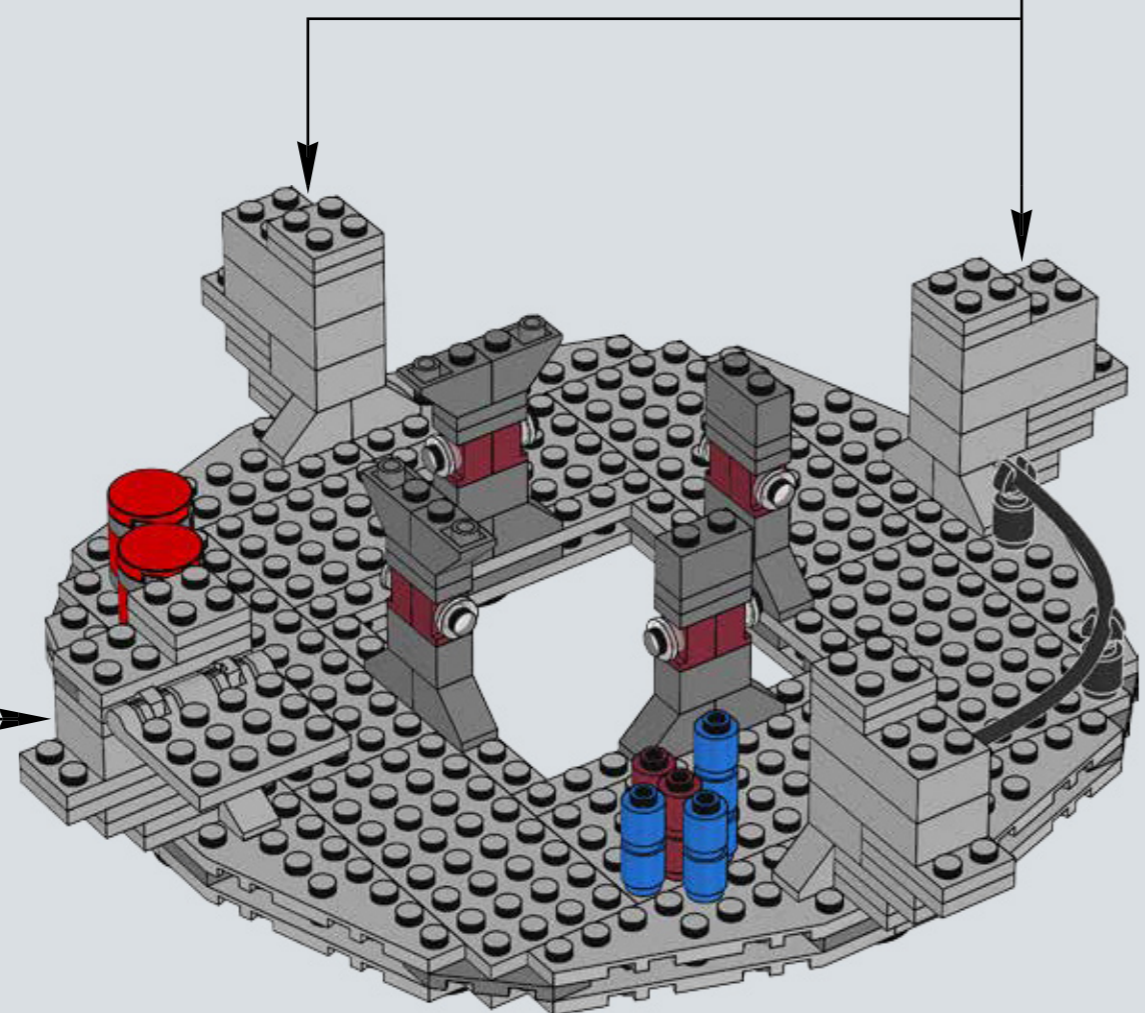
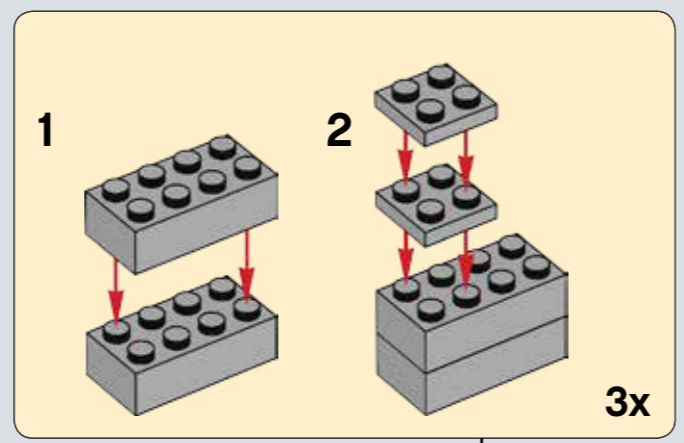
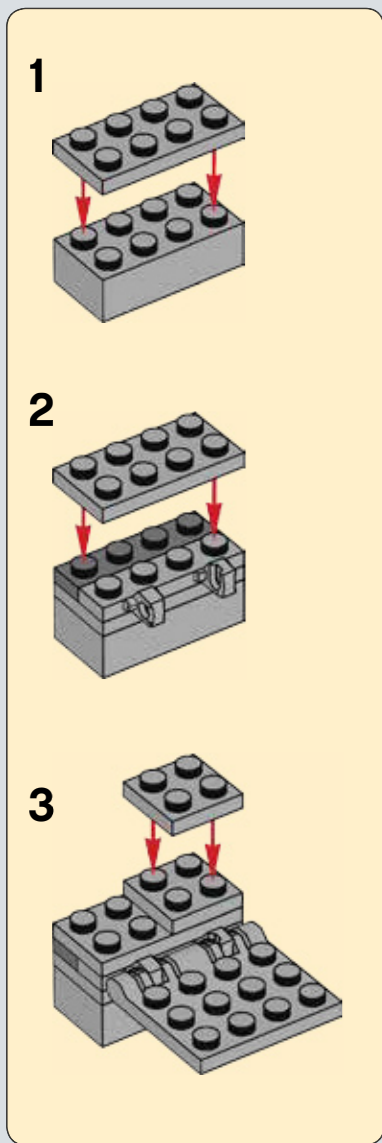

# 19

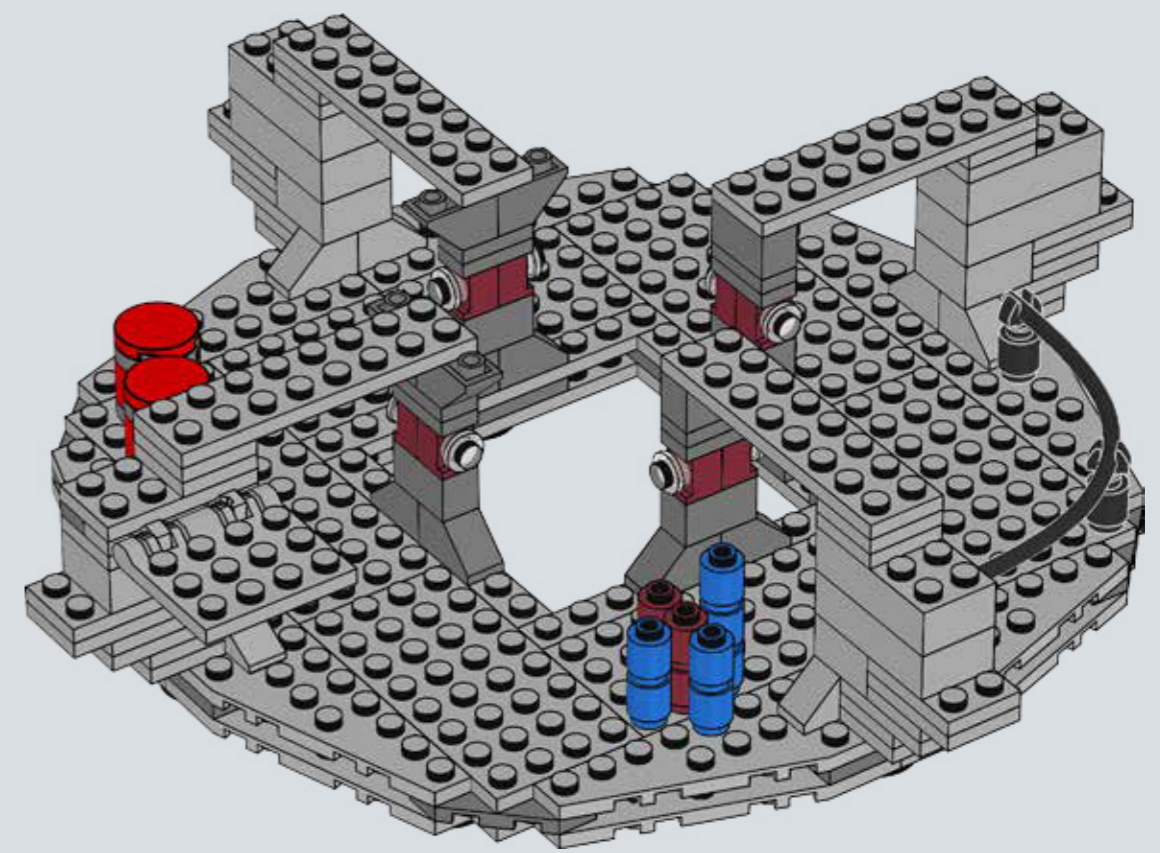

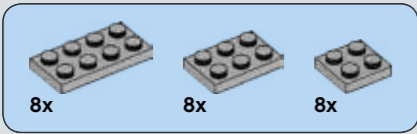

20

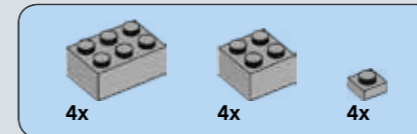
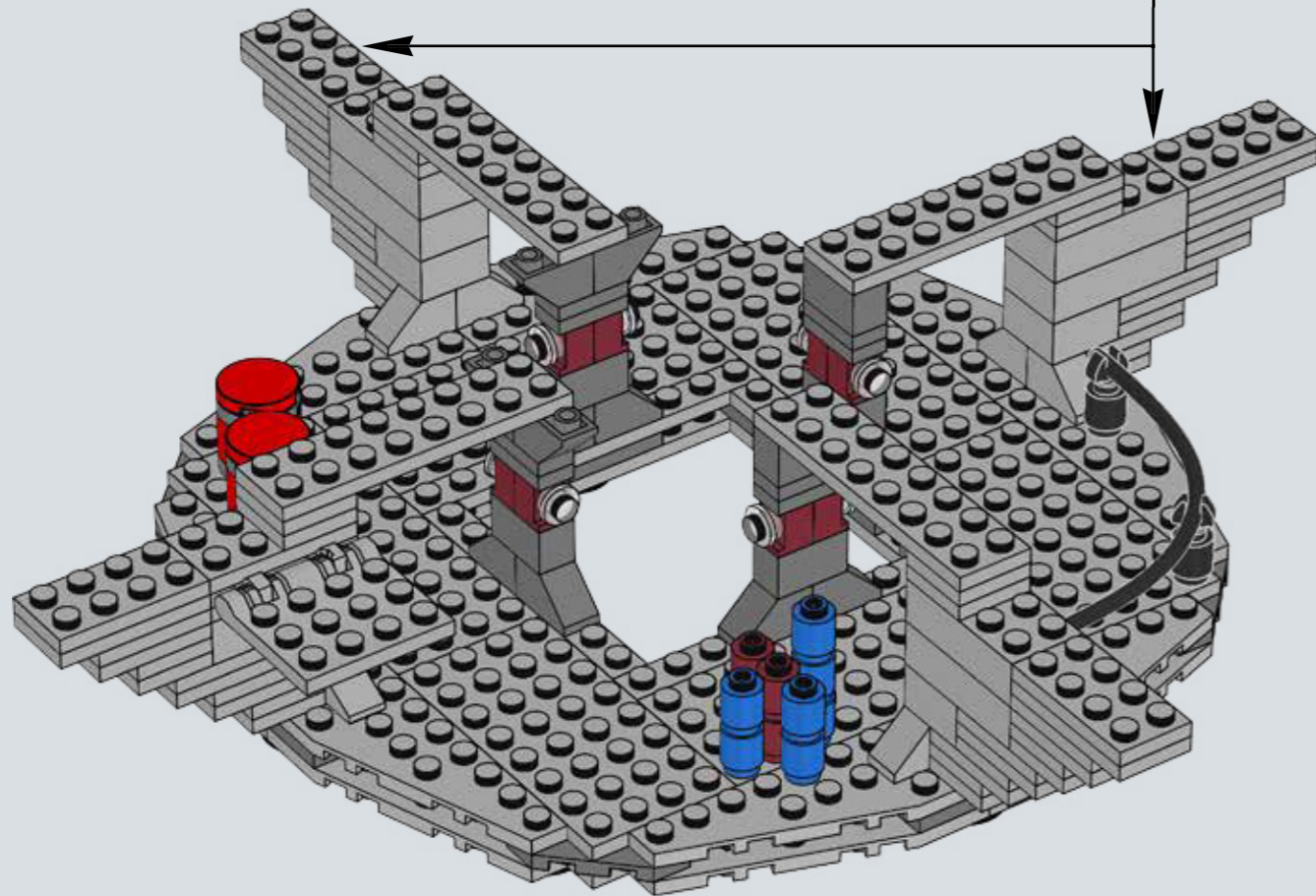
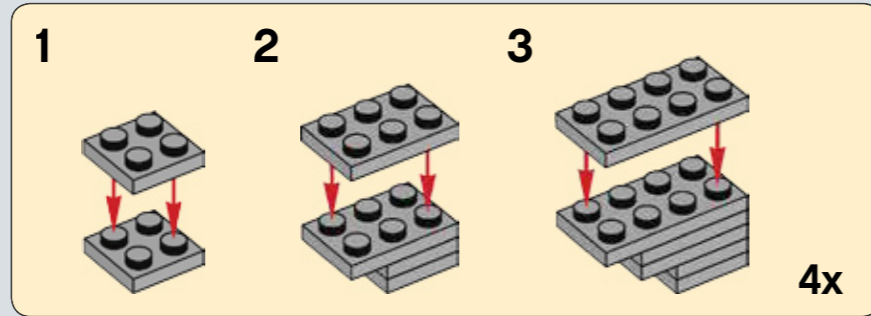

21

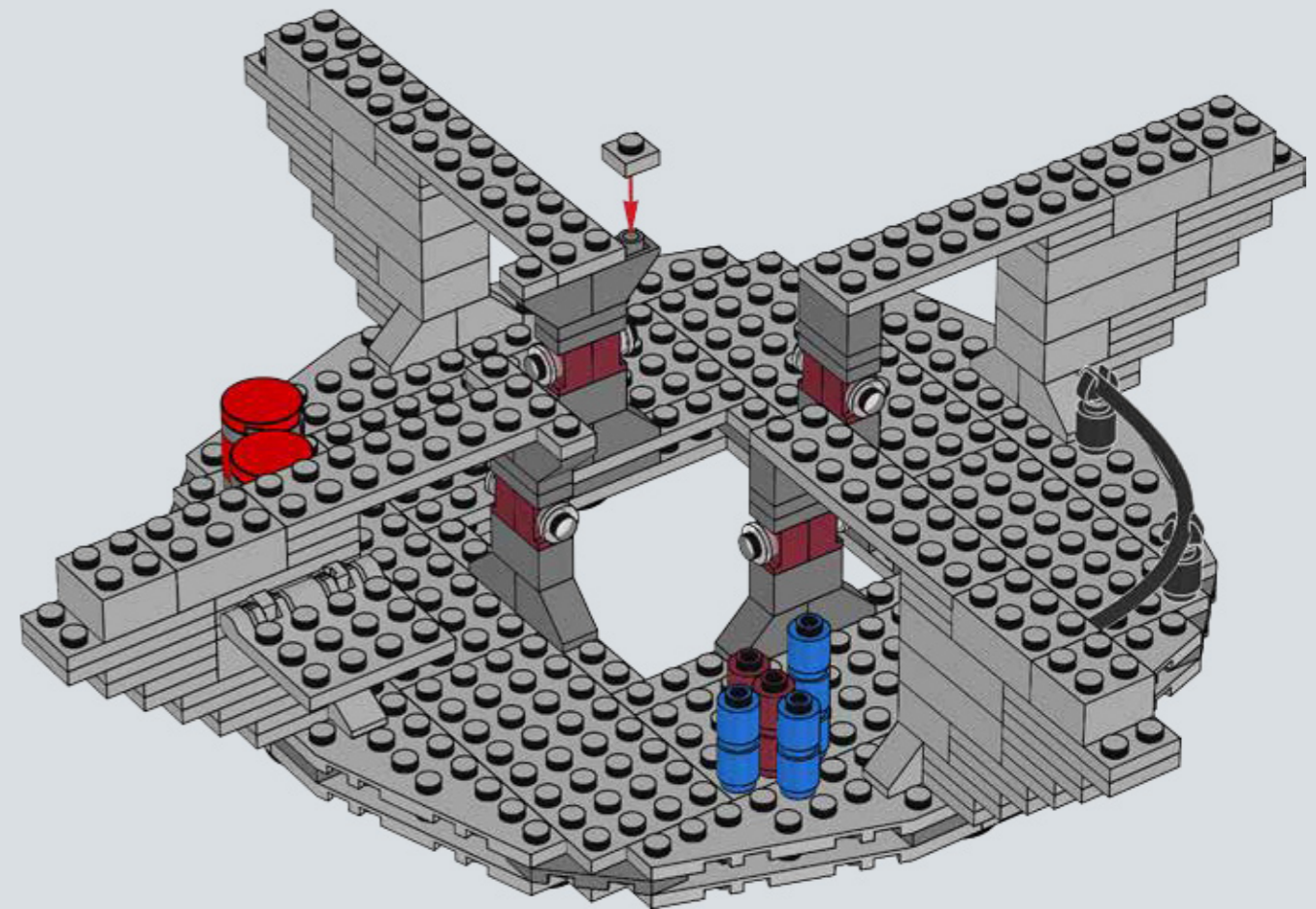

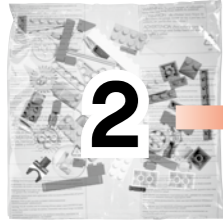

2x



6x

# 22

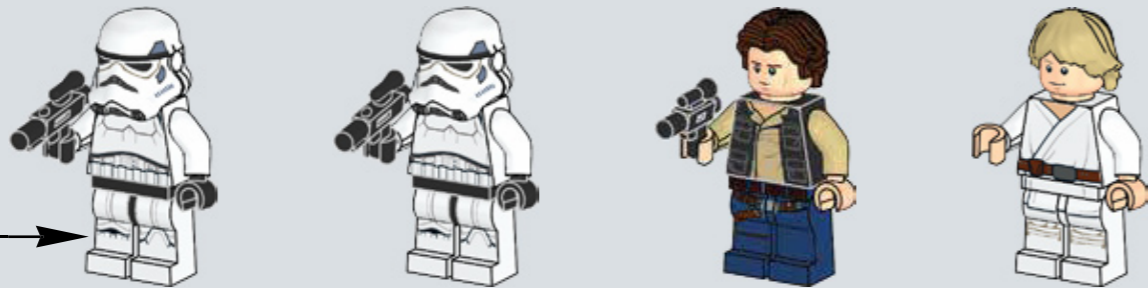
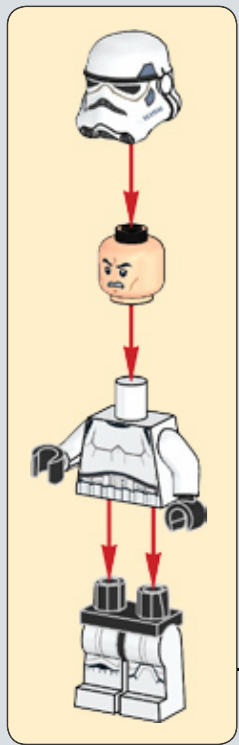
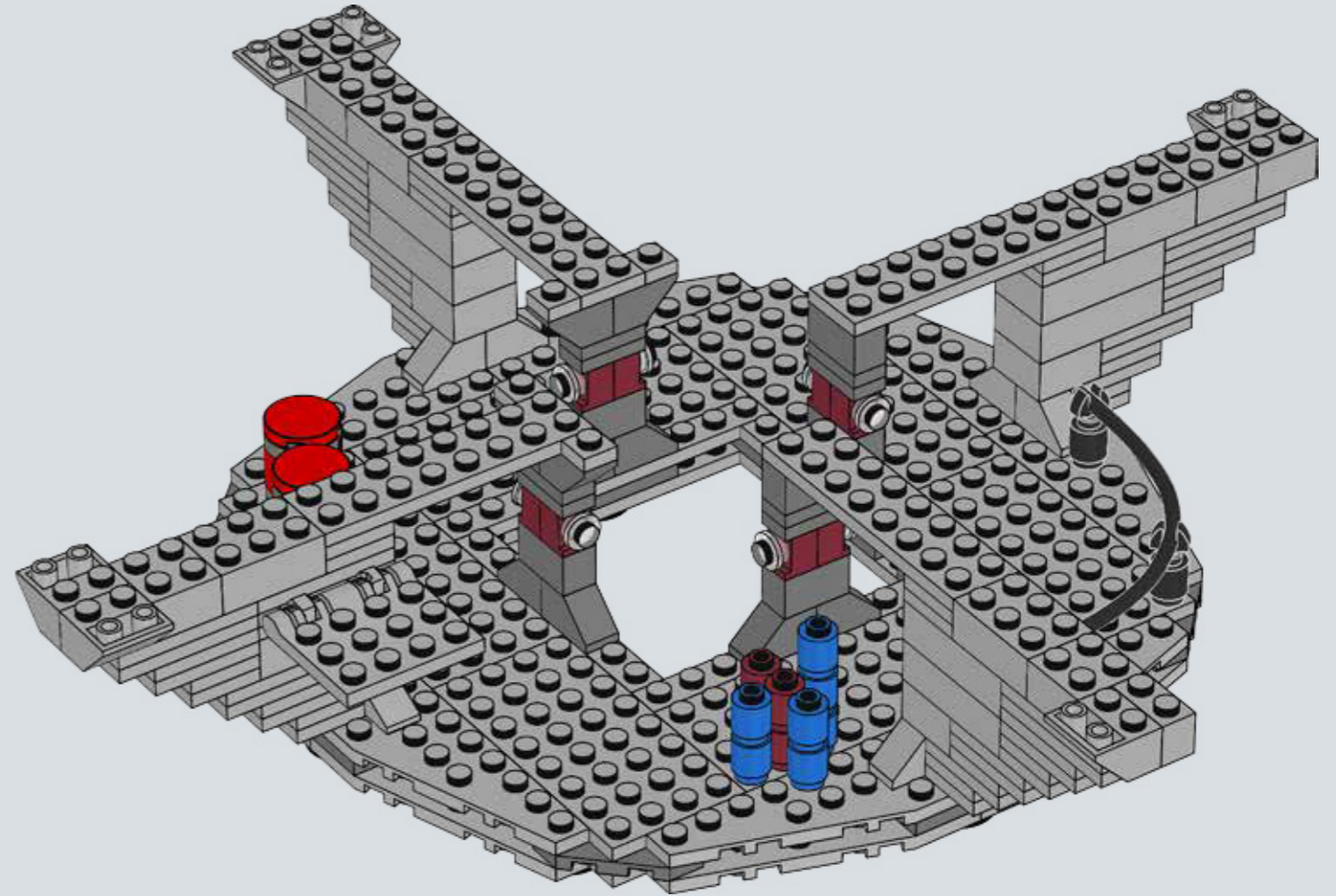

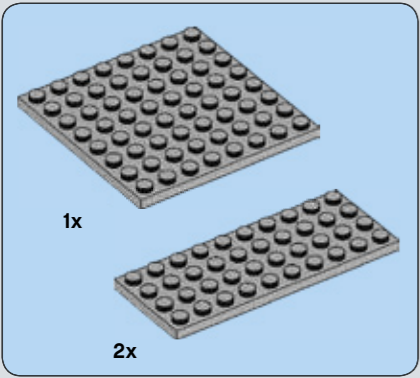
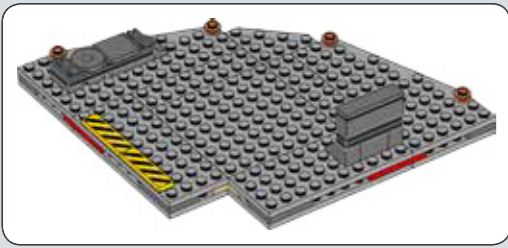

23

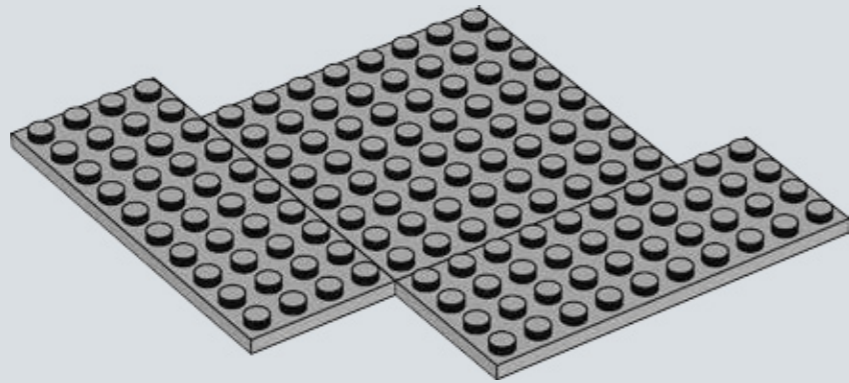

24

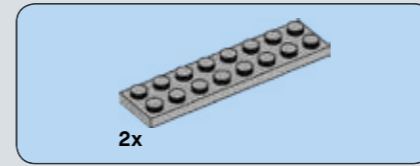
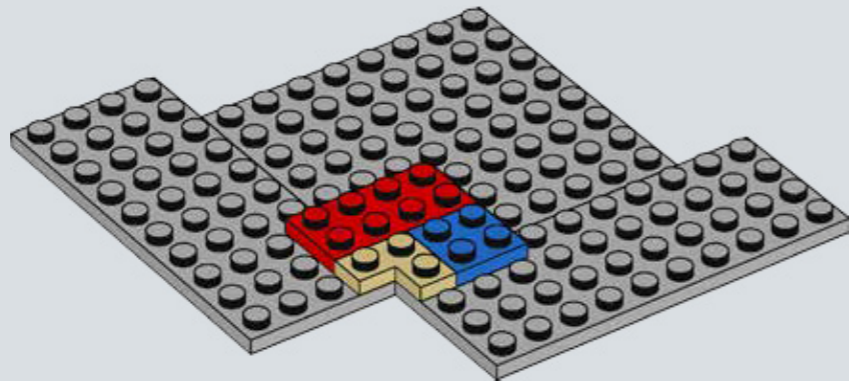

25

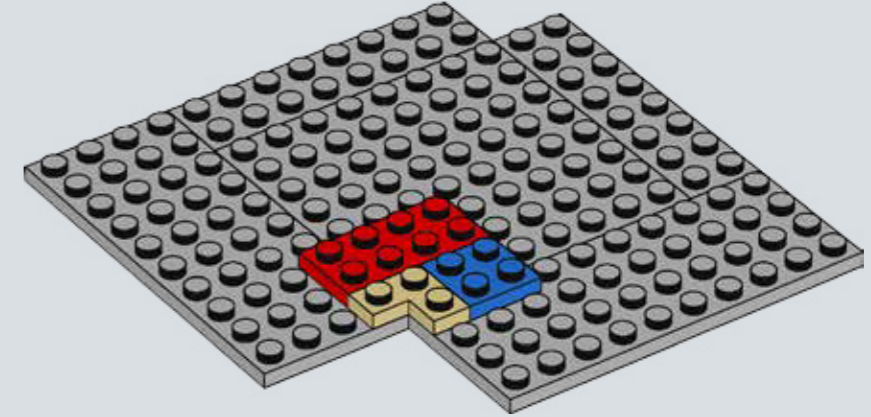

26

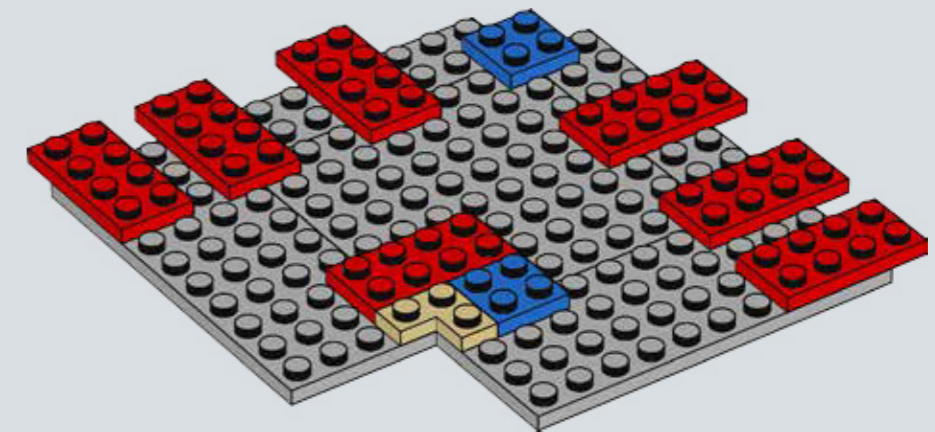

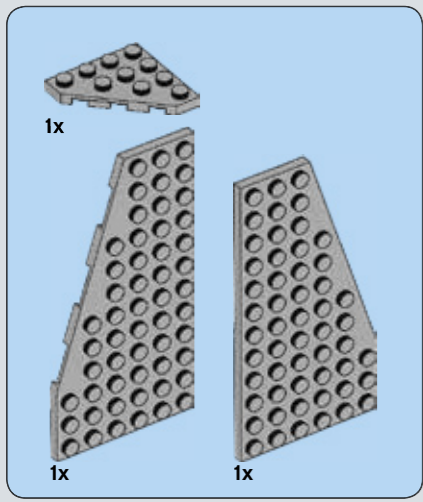

27

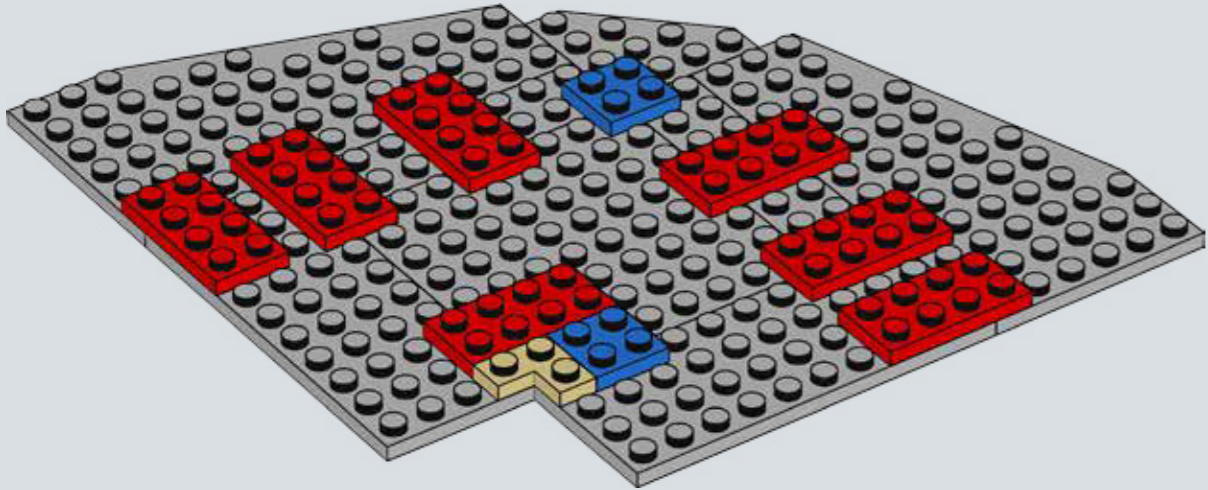

28

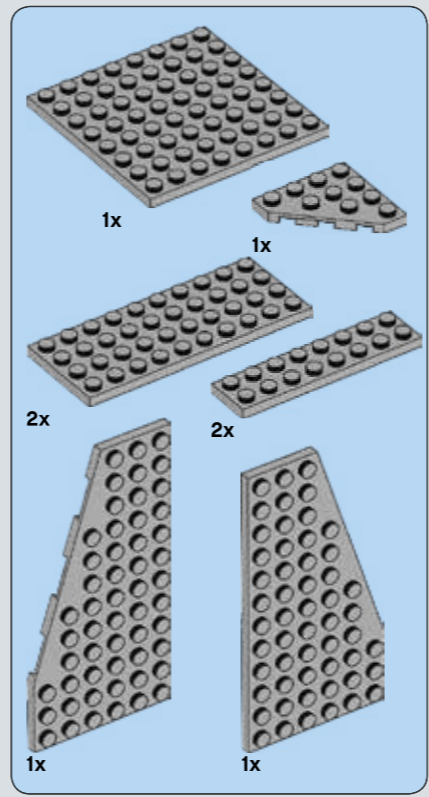
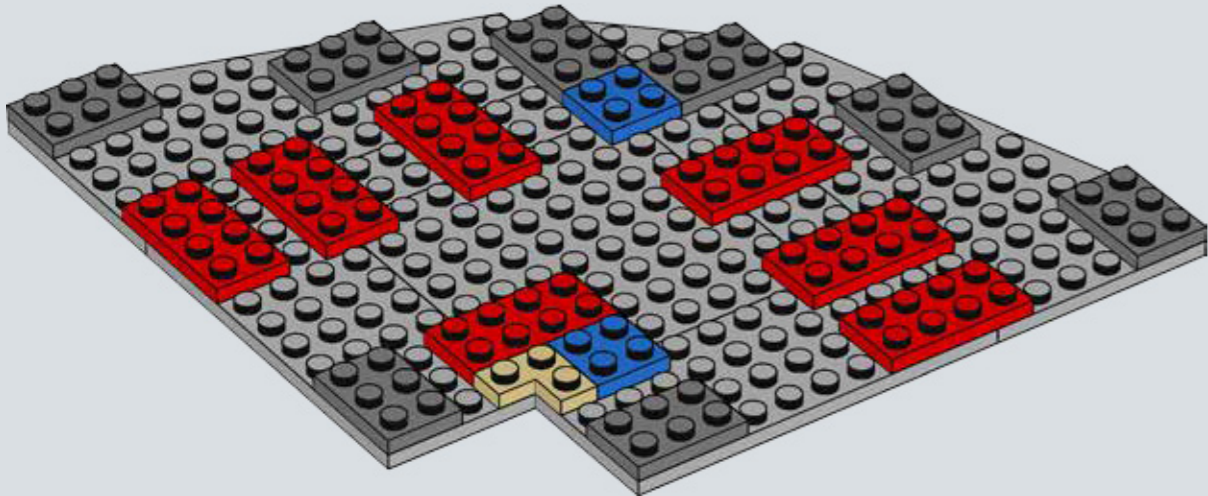

29

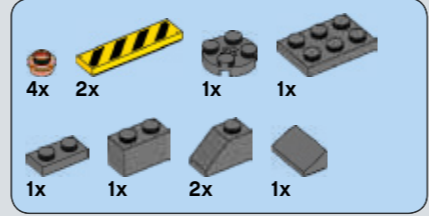
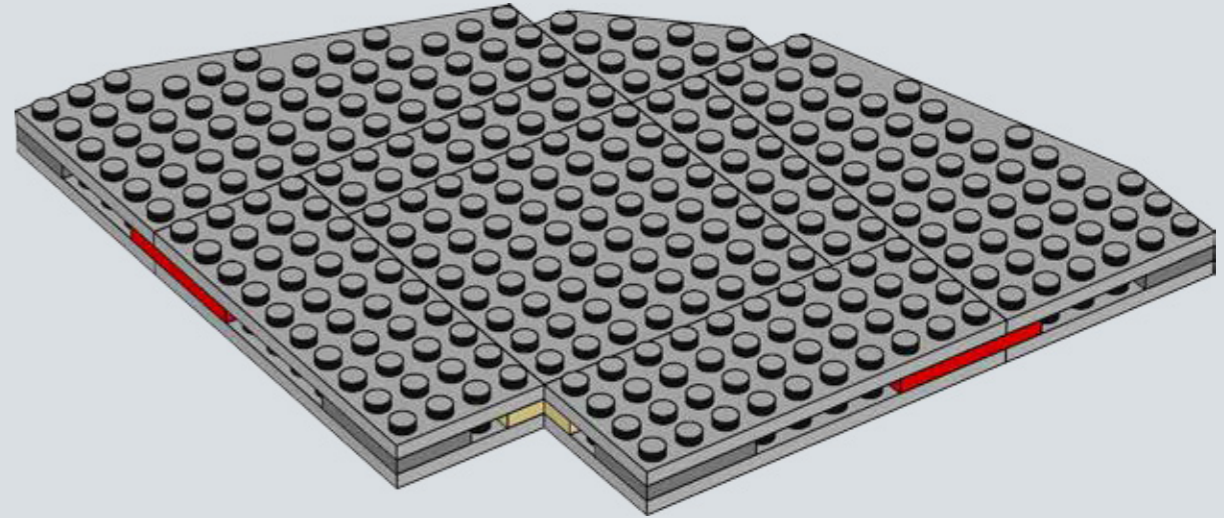

30

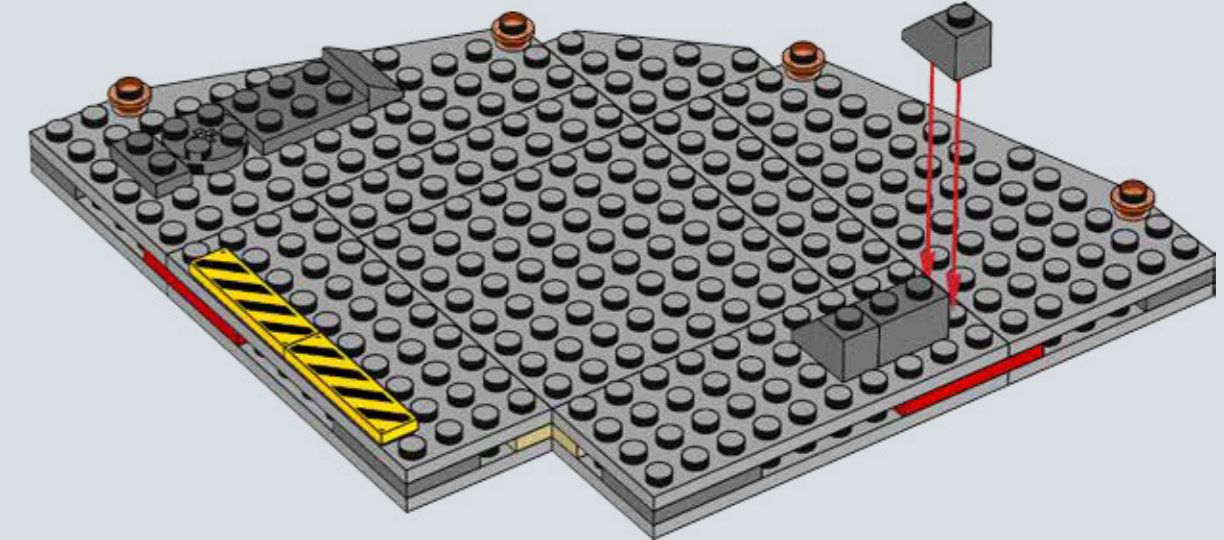



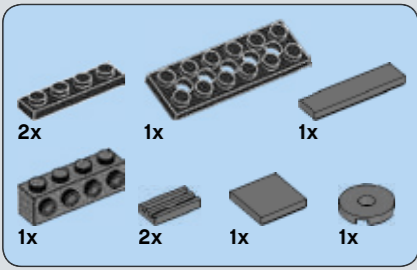

31

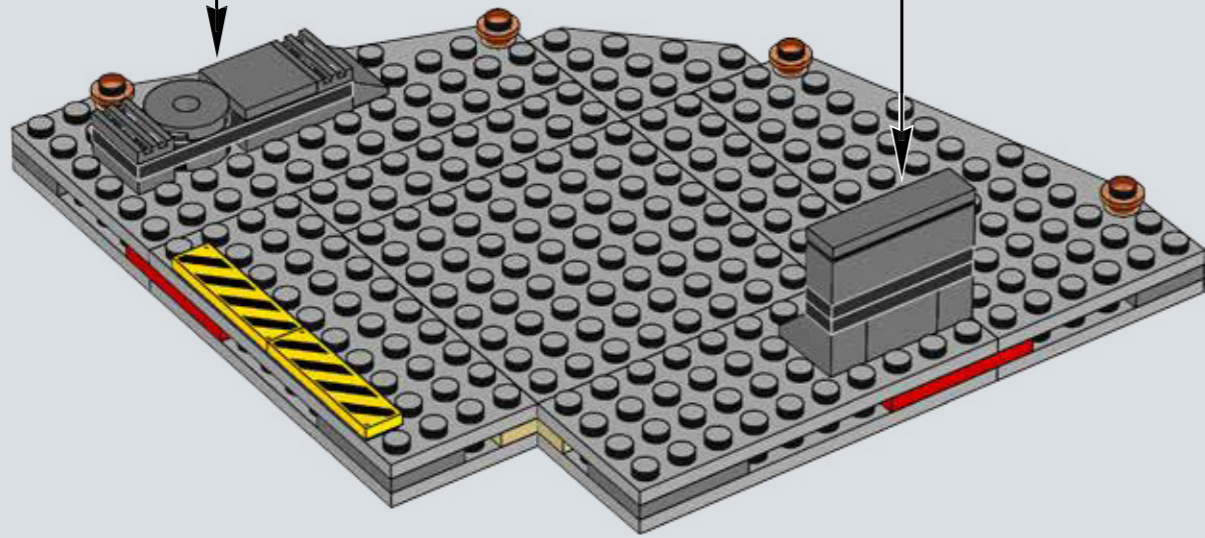
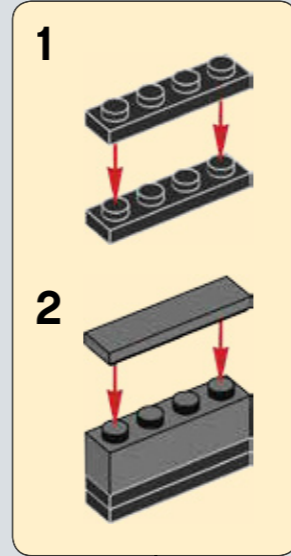
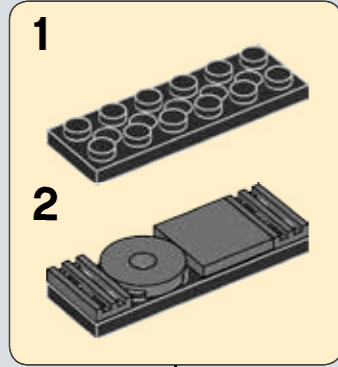

32

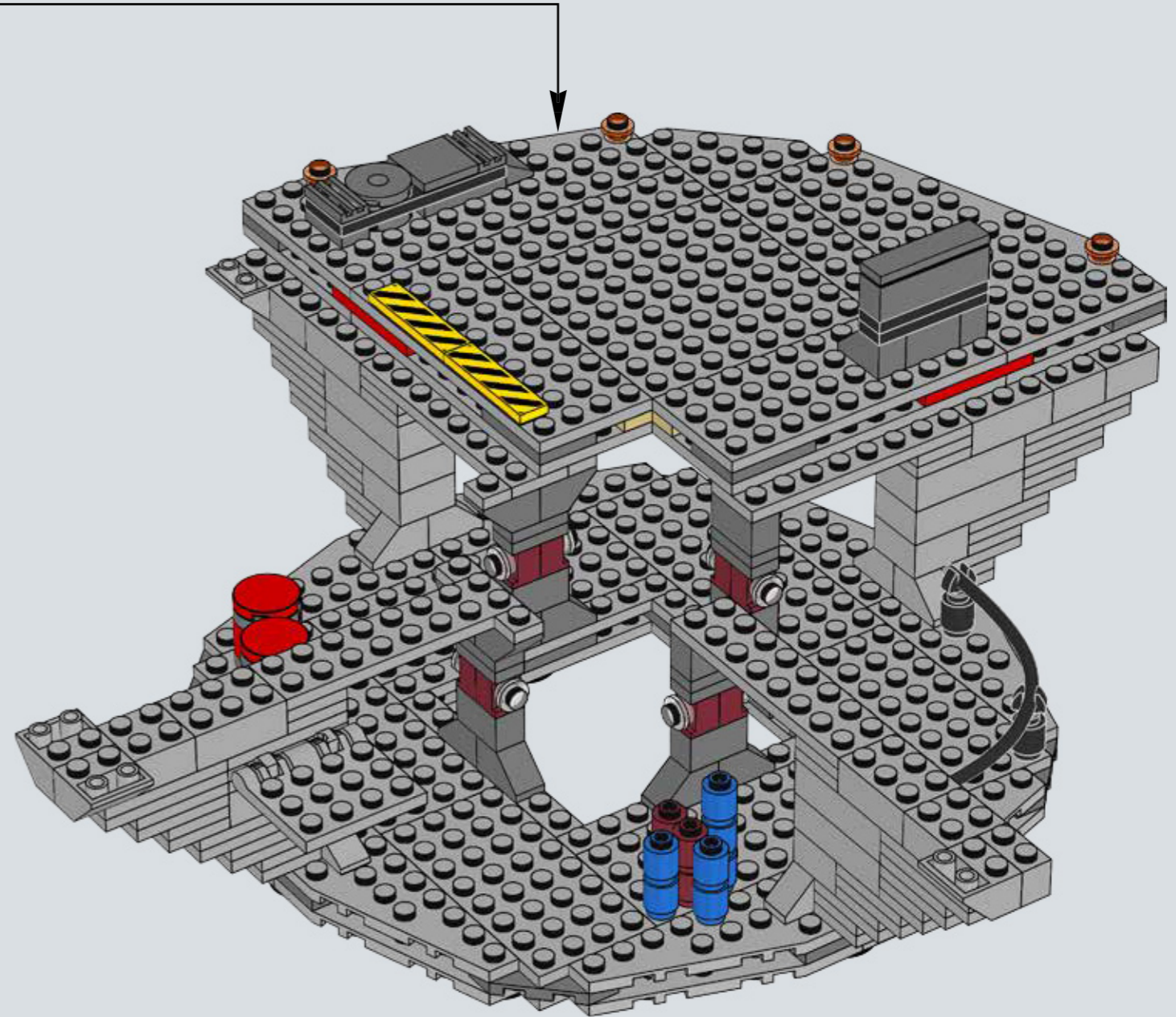

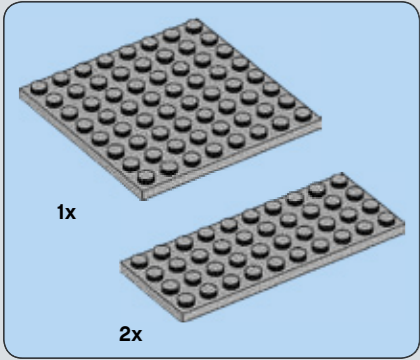
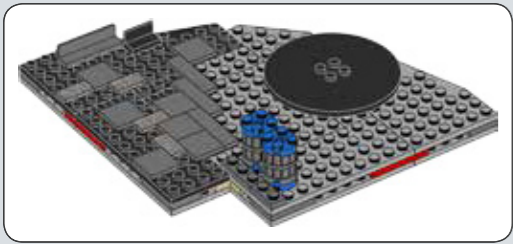

33

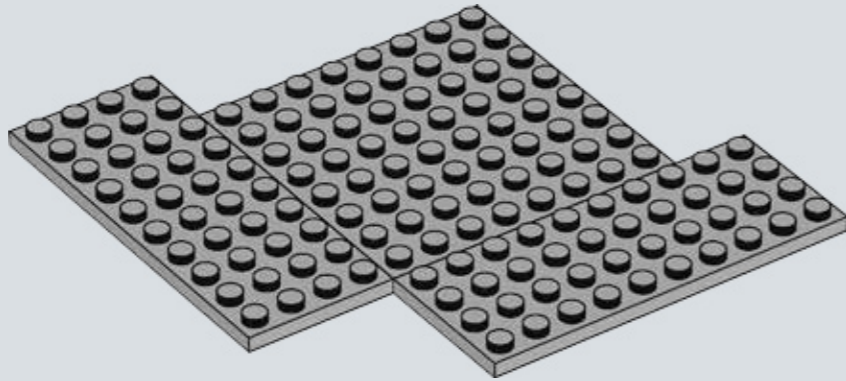

34

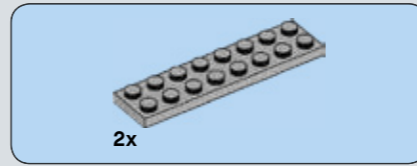
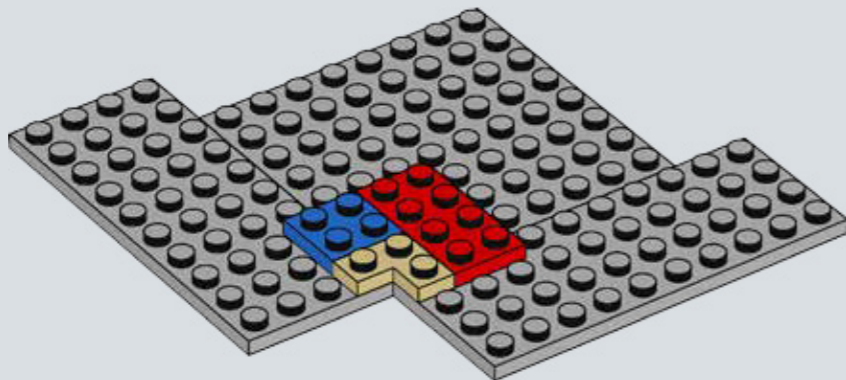

35

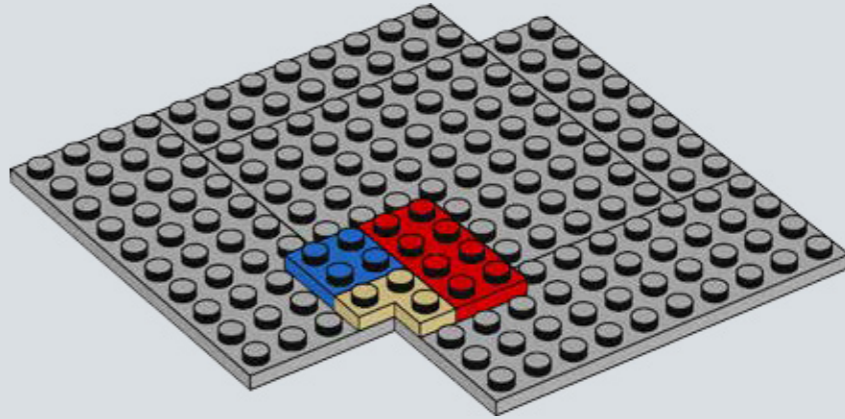

36

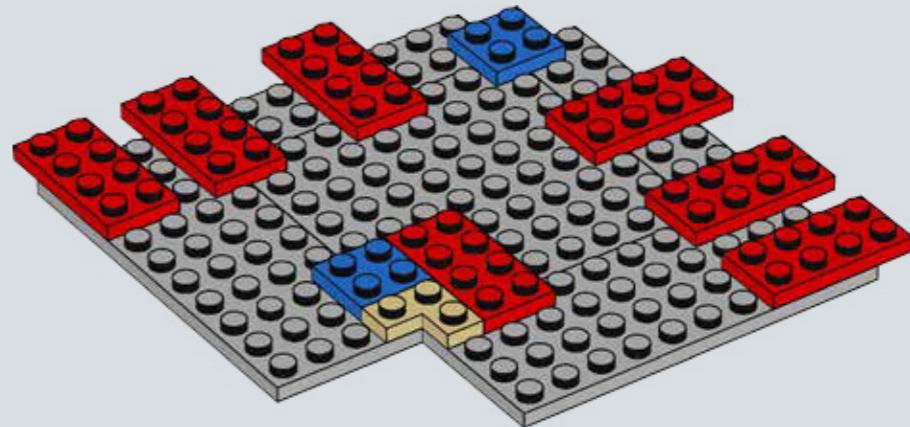

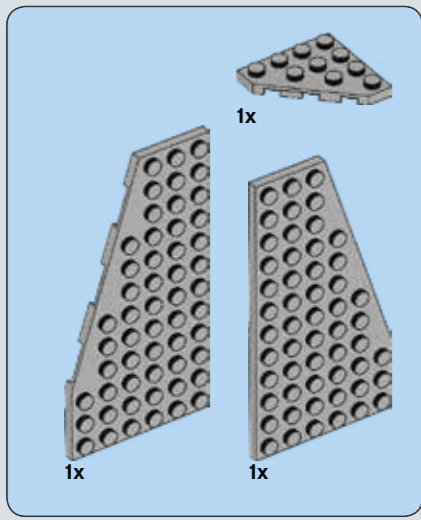

37

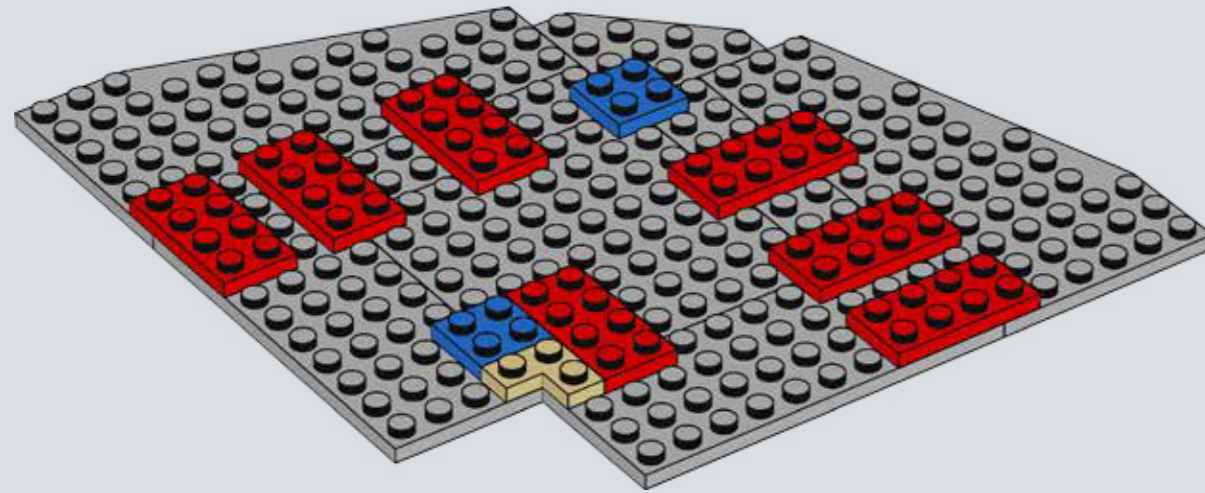

38

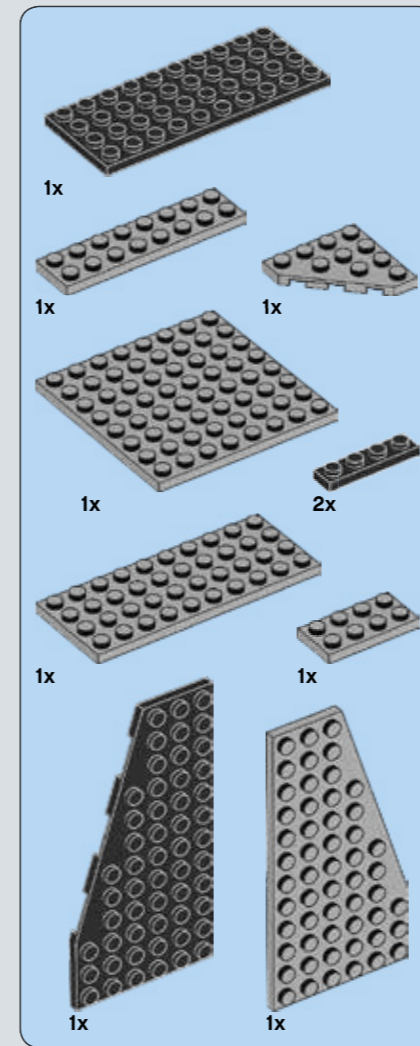
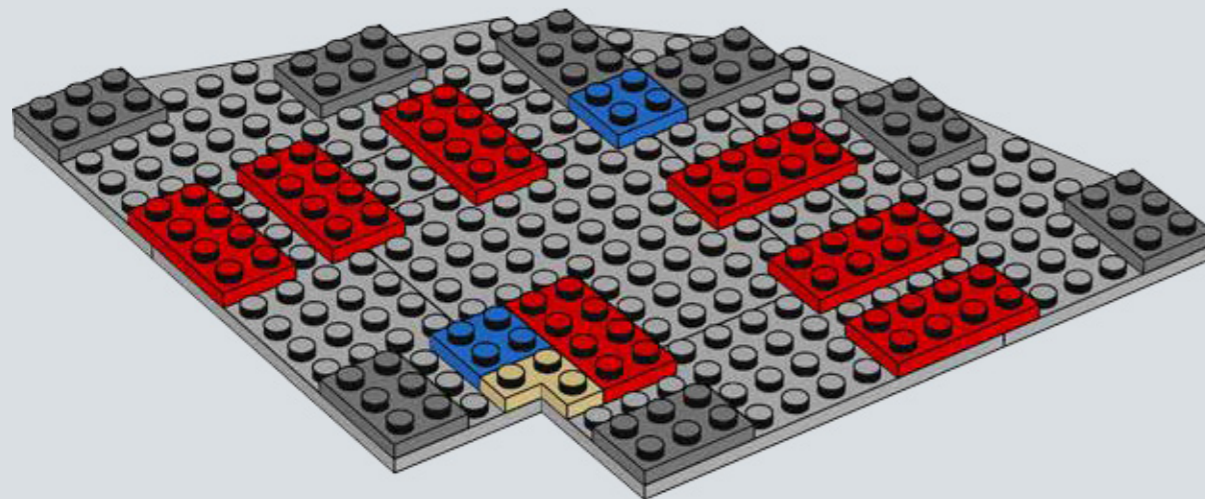

39

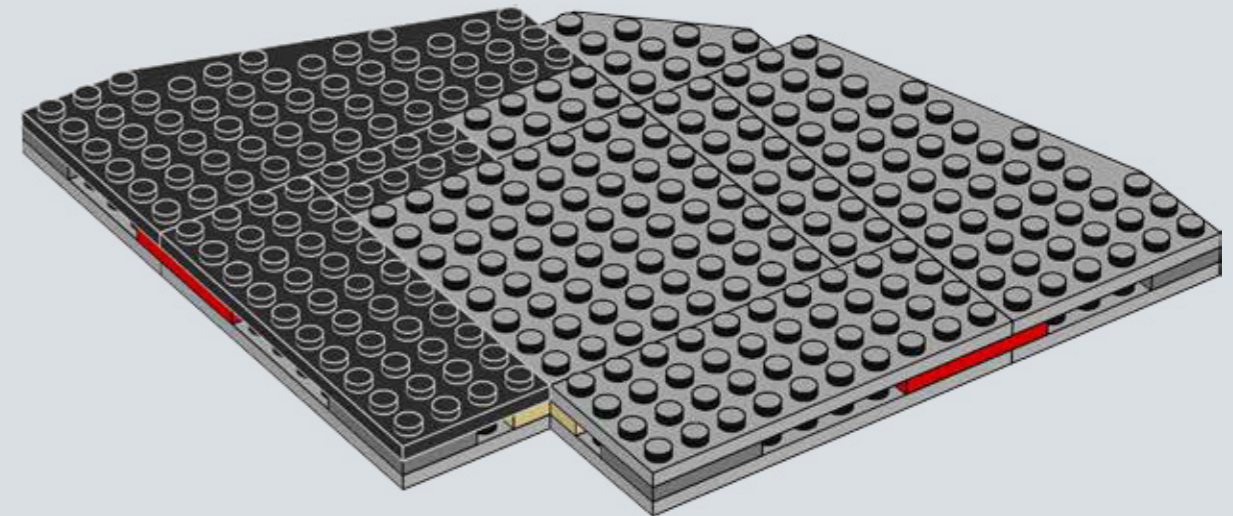

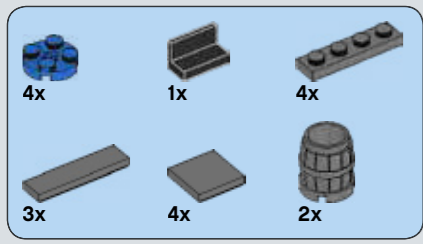

40

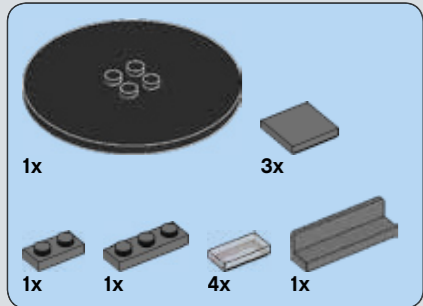
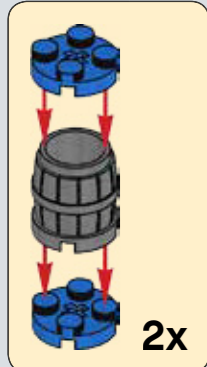
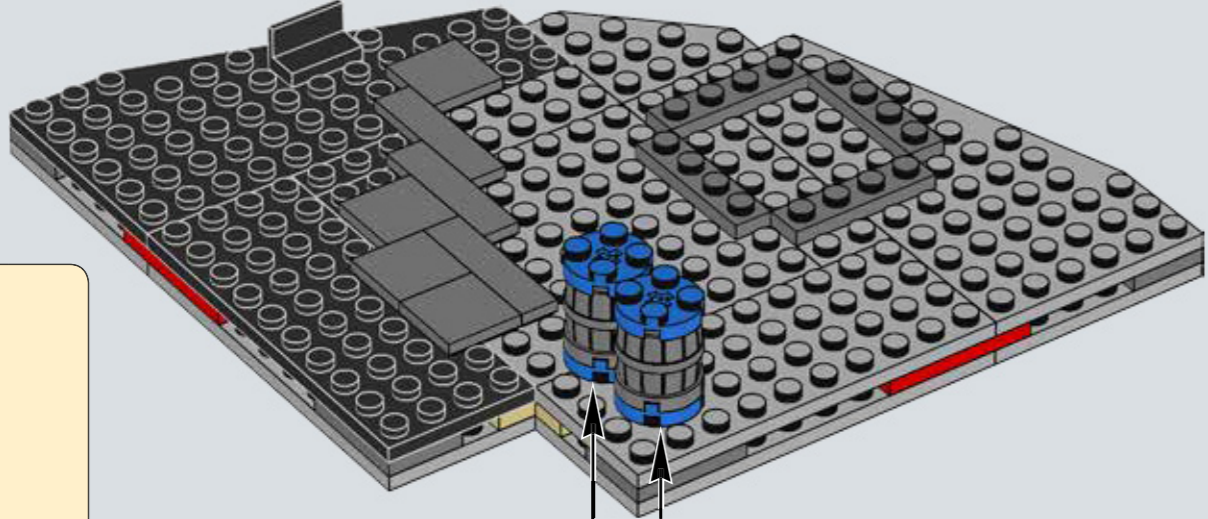

41

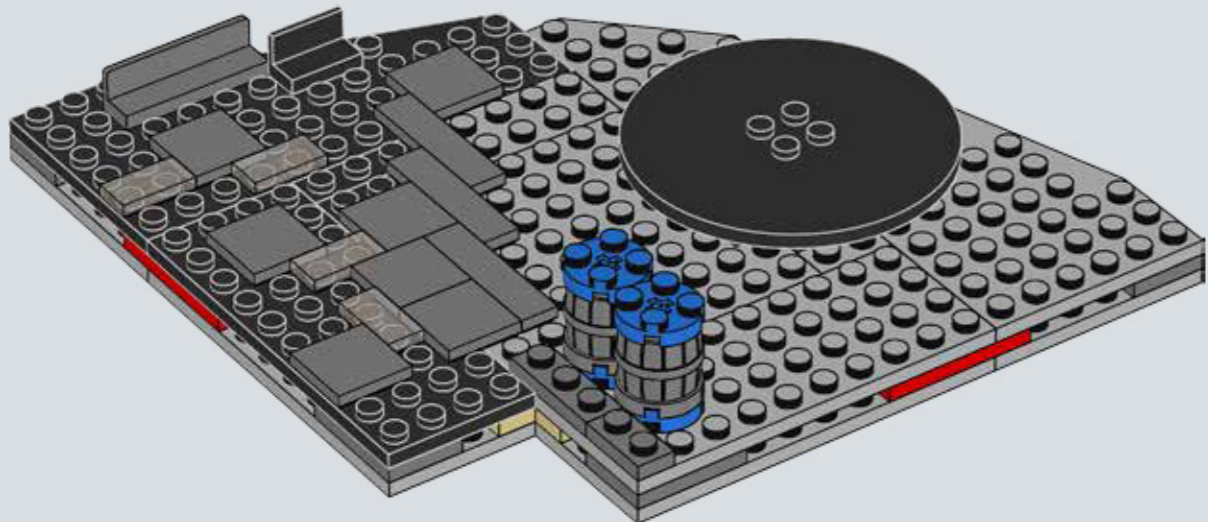

42

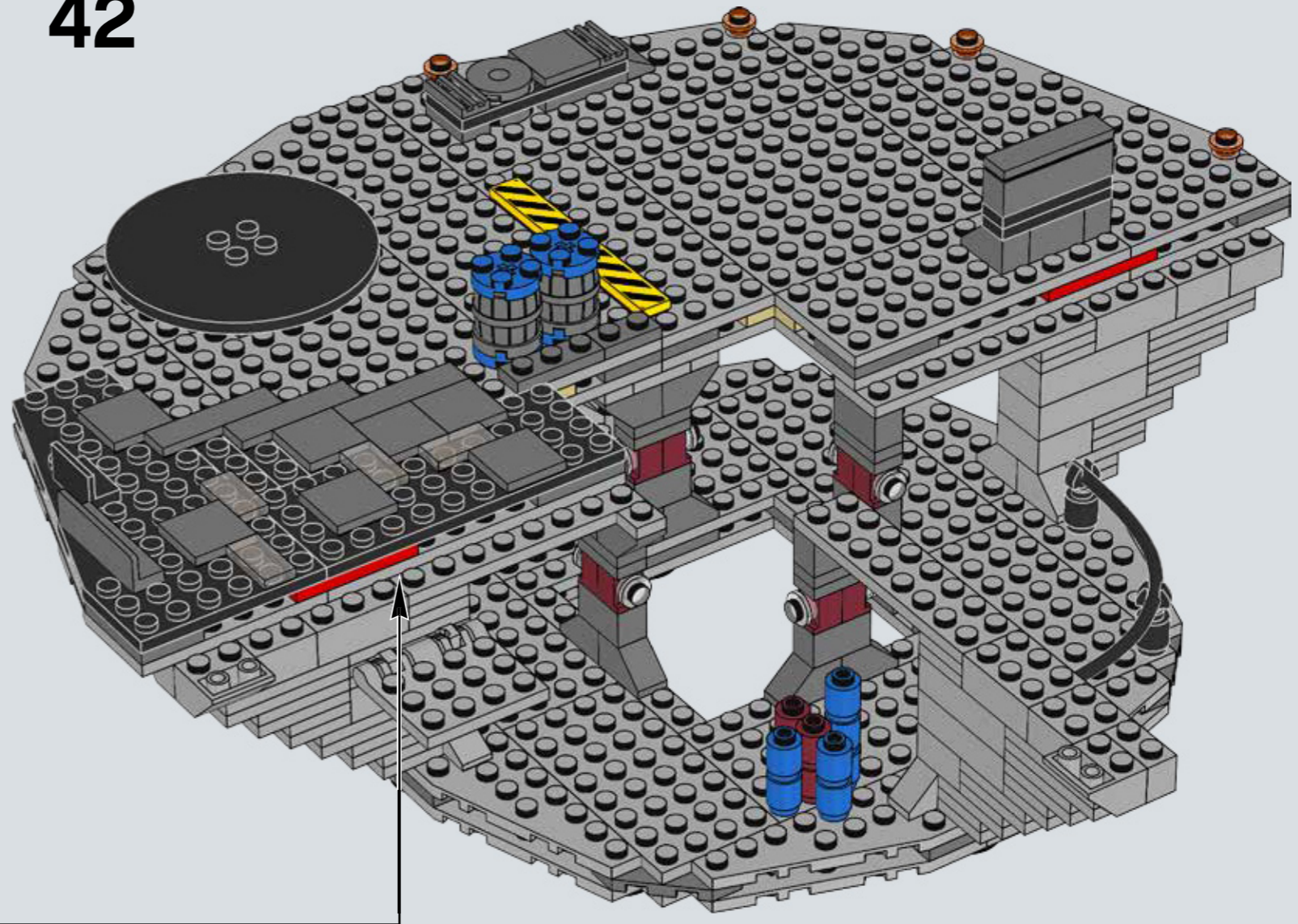

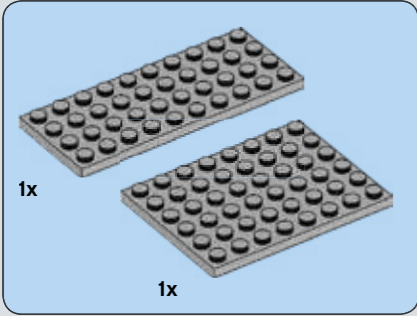
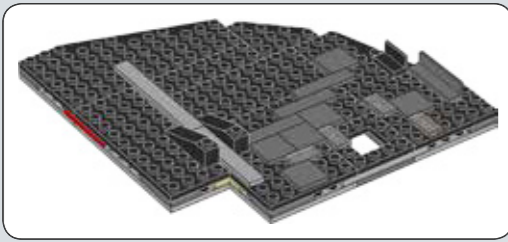

43

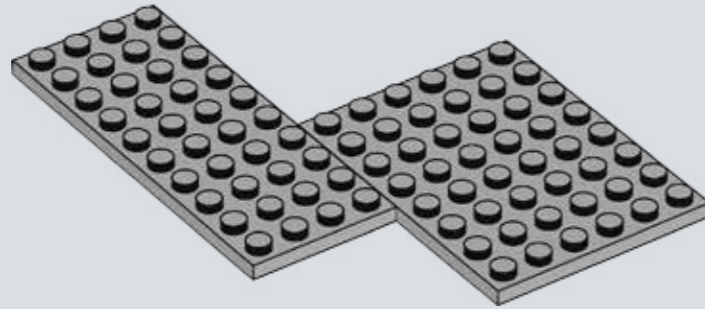

44

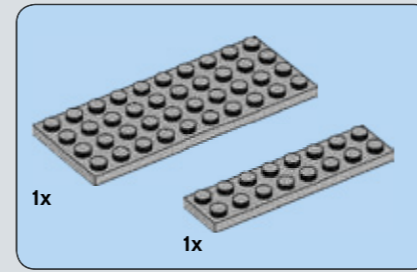
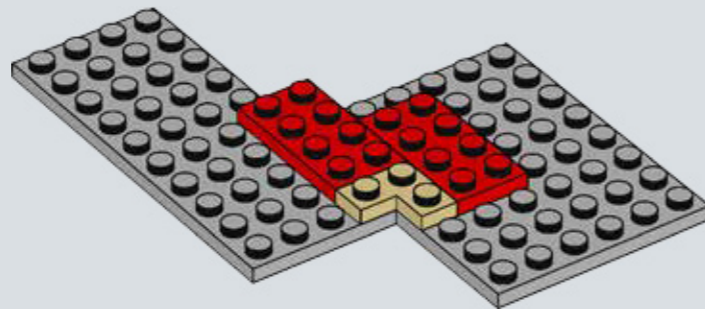

45

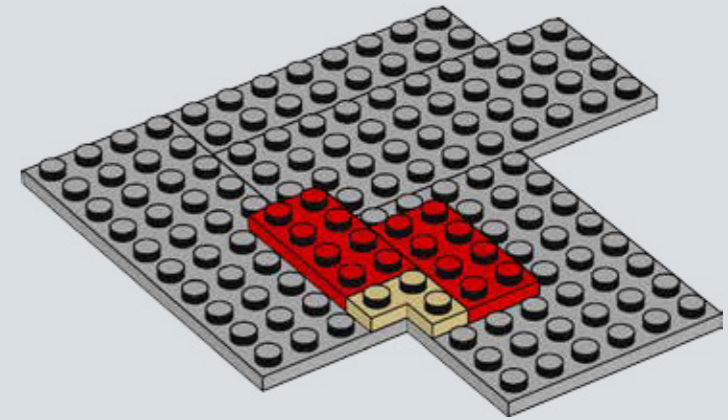

46

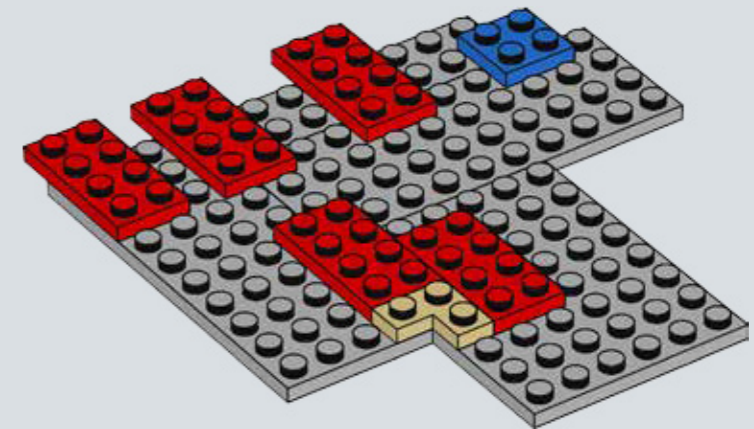

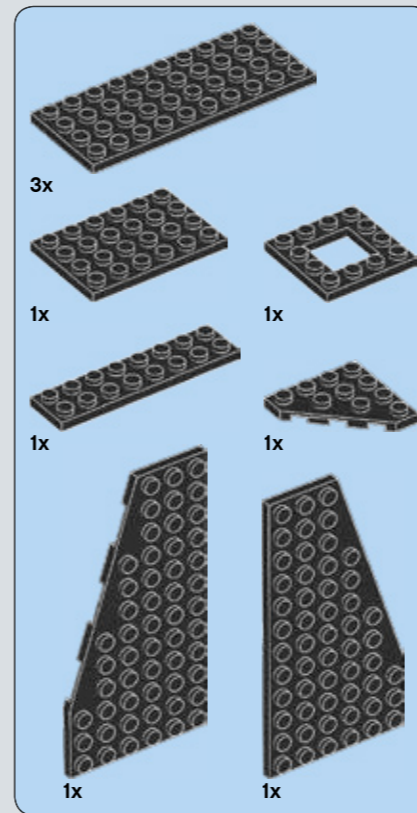
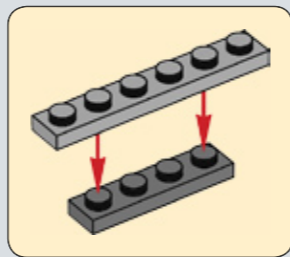
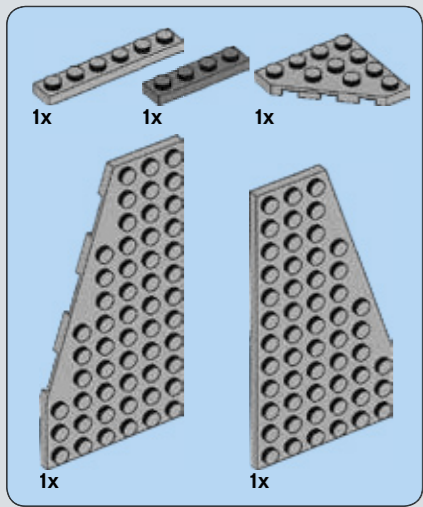

47

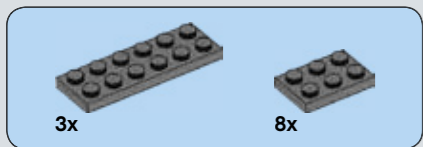
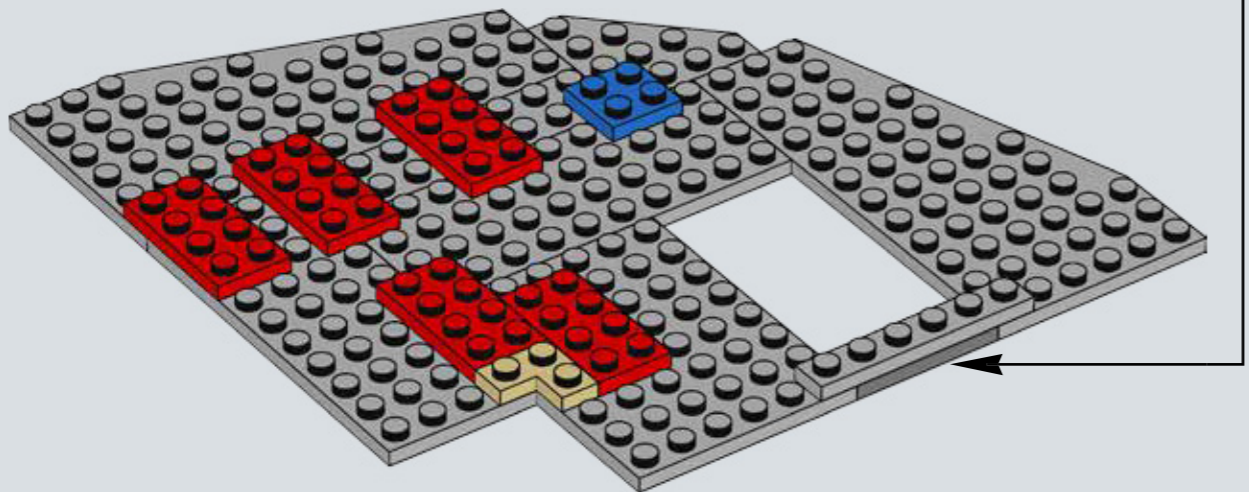

48

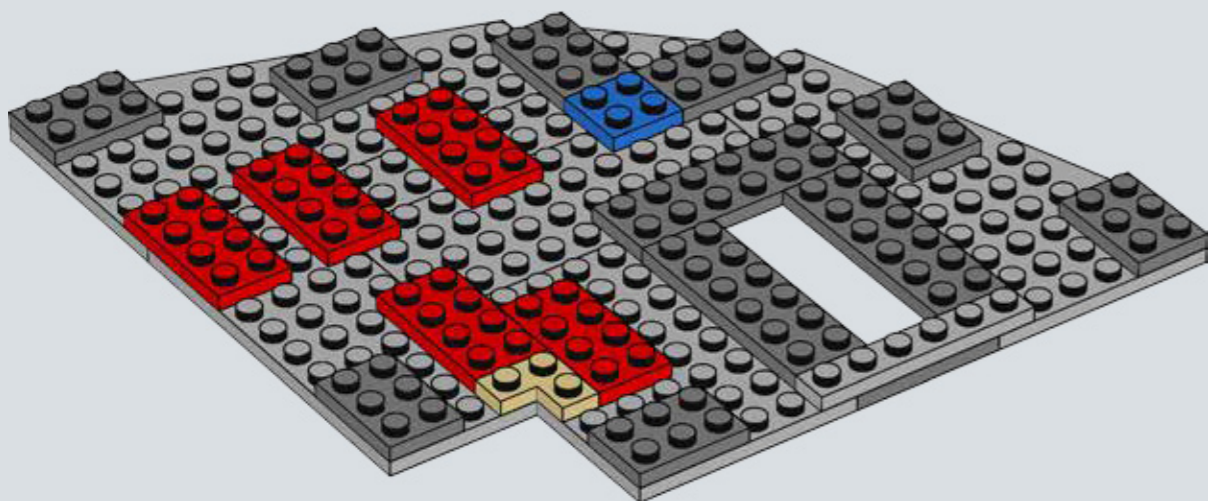

49

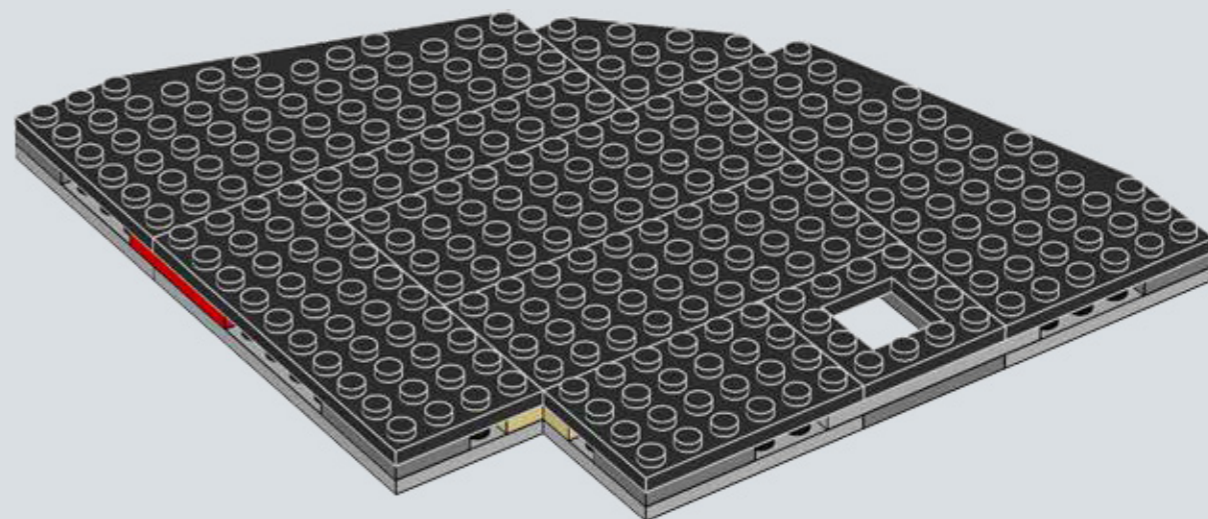

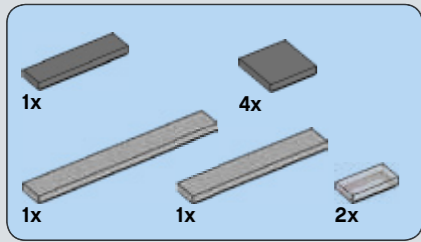

50

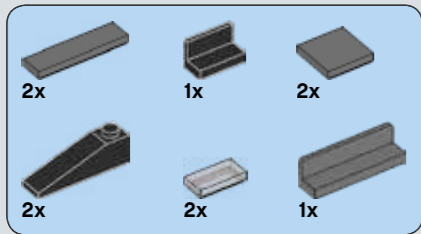
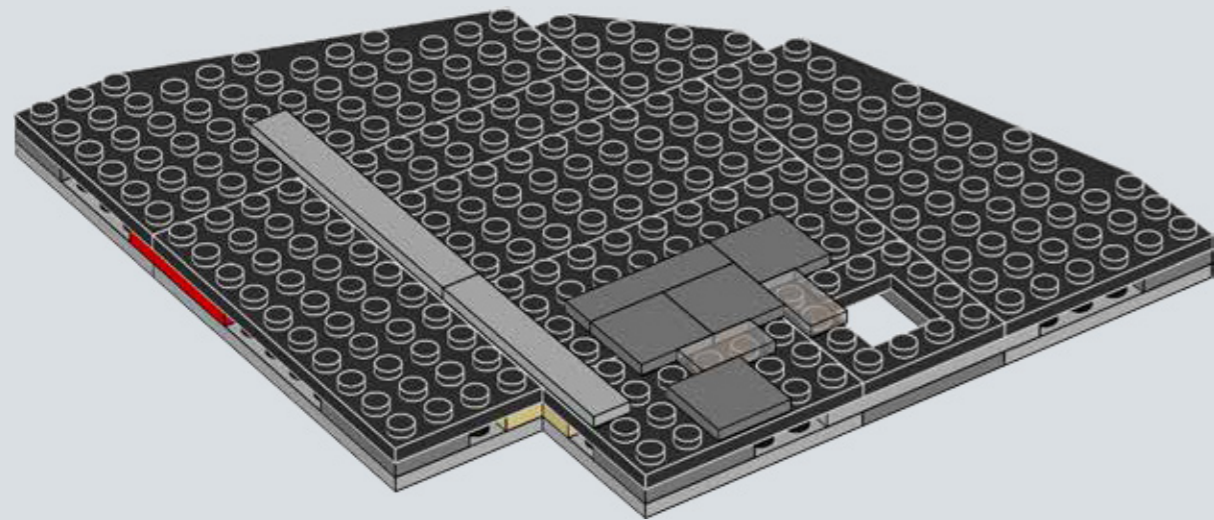

51

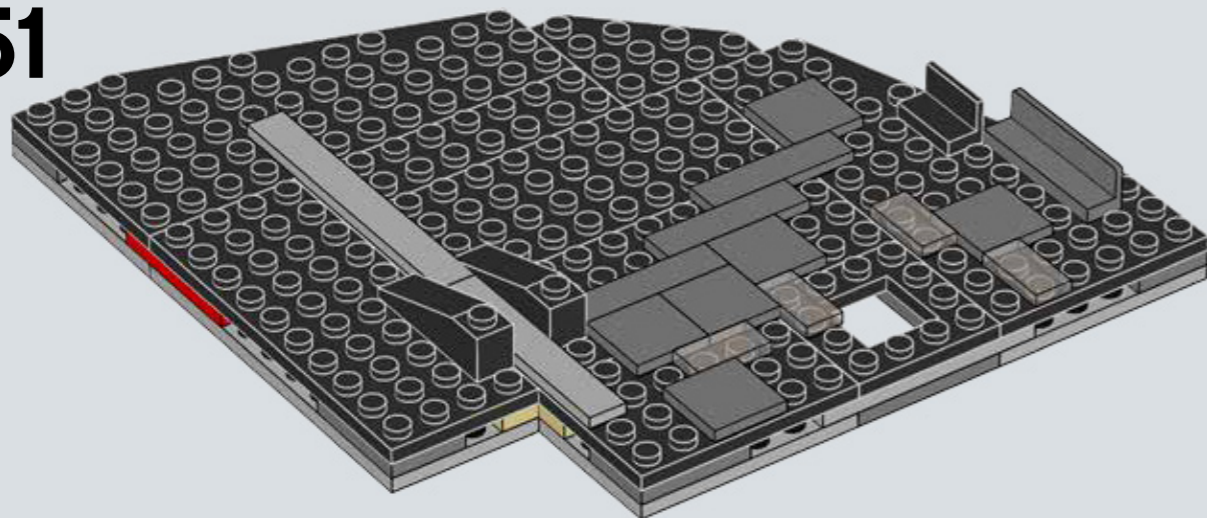

52

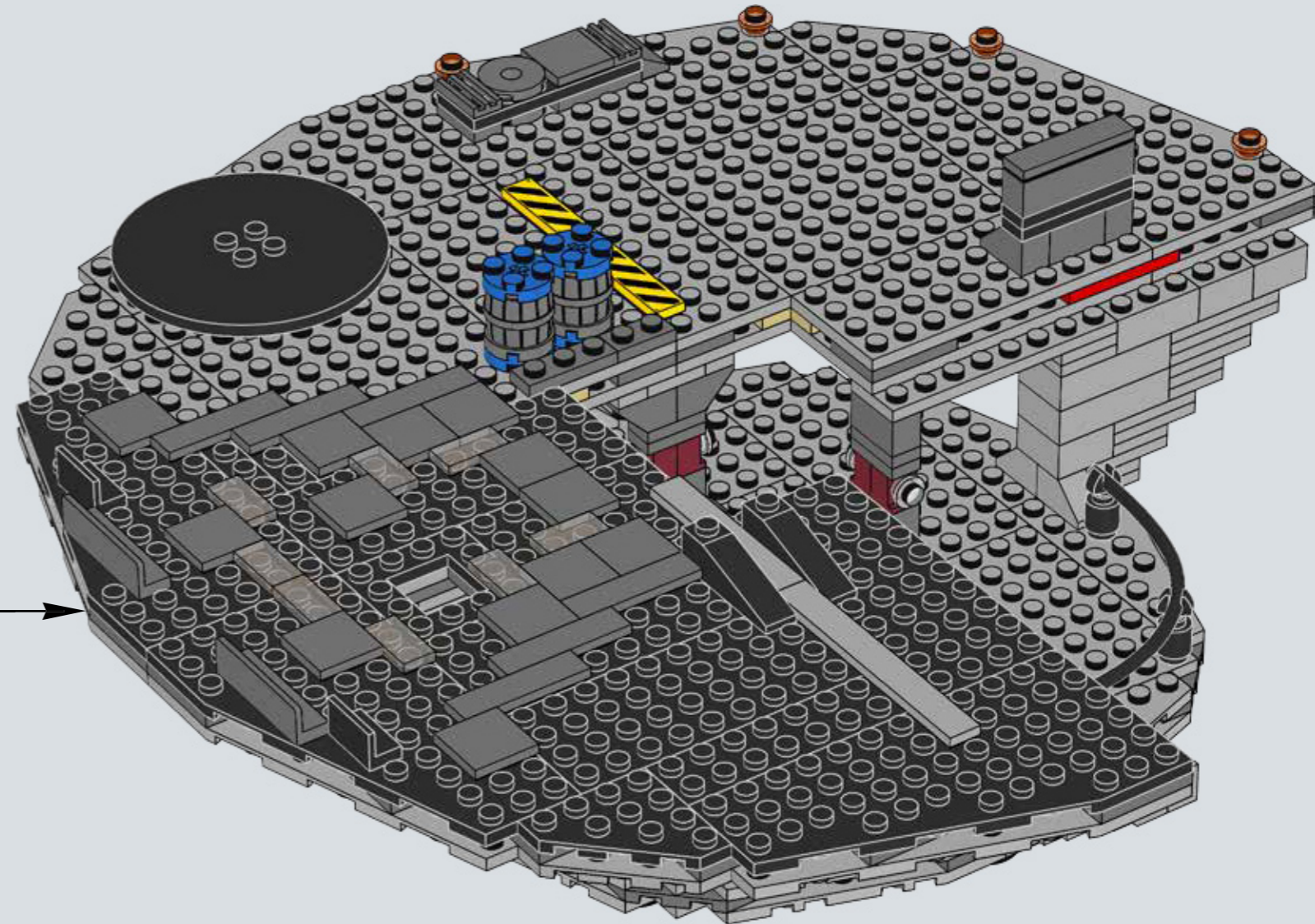

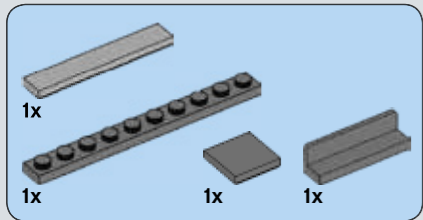

# 53

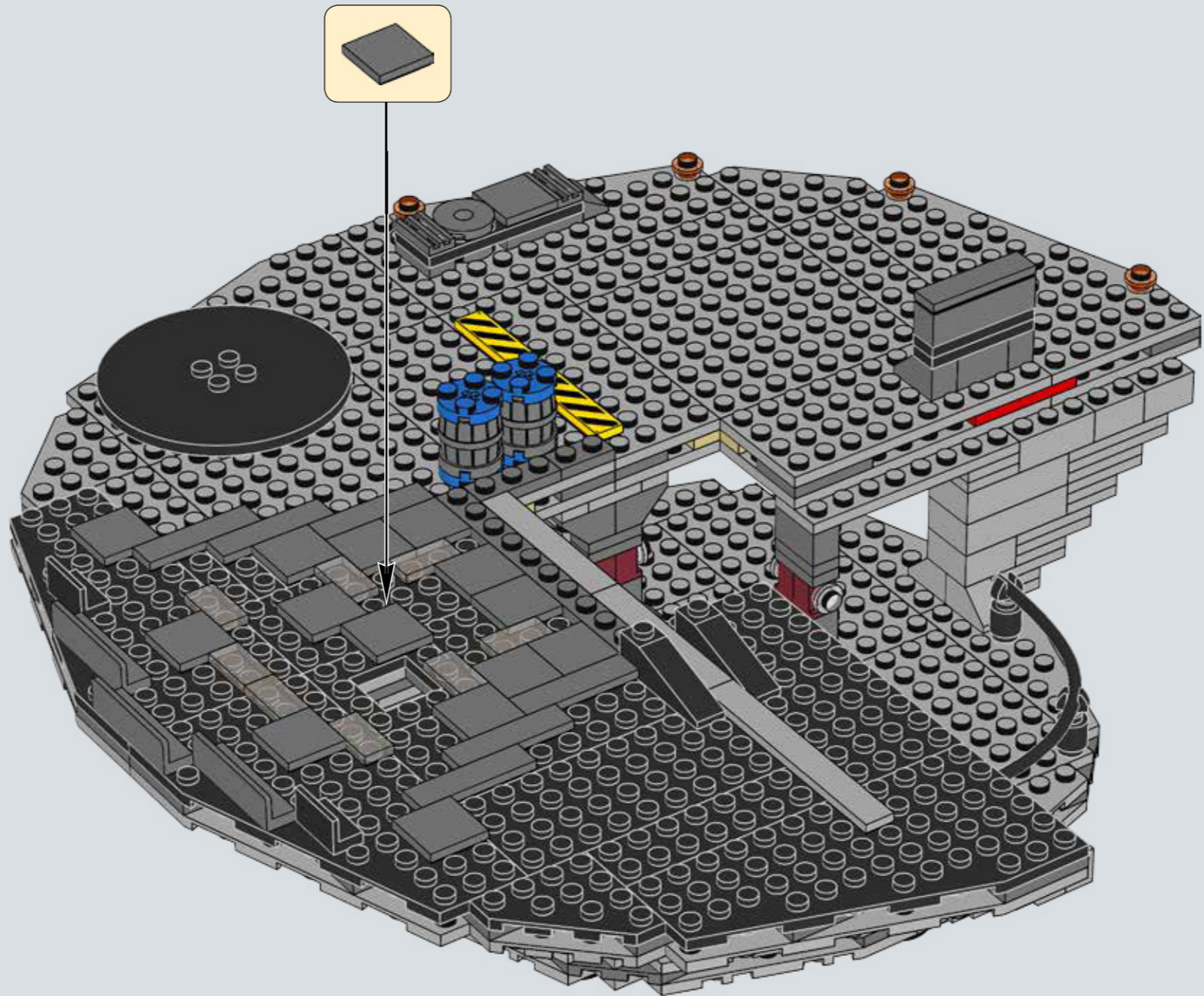



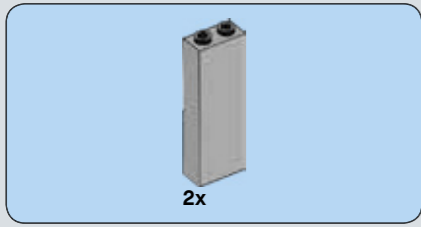

54

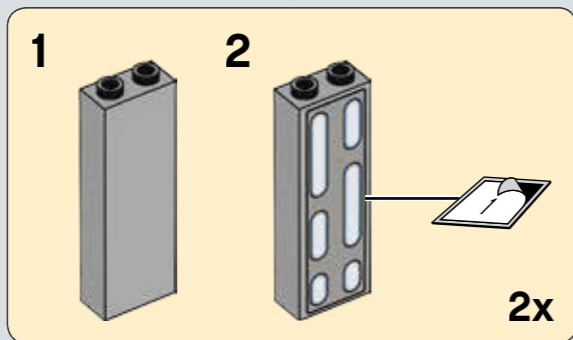
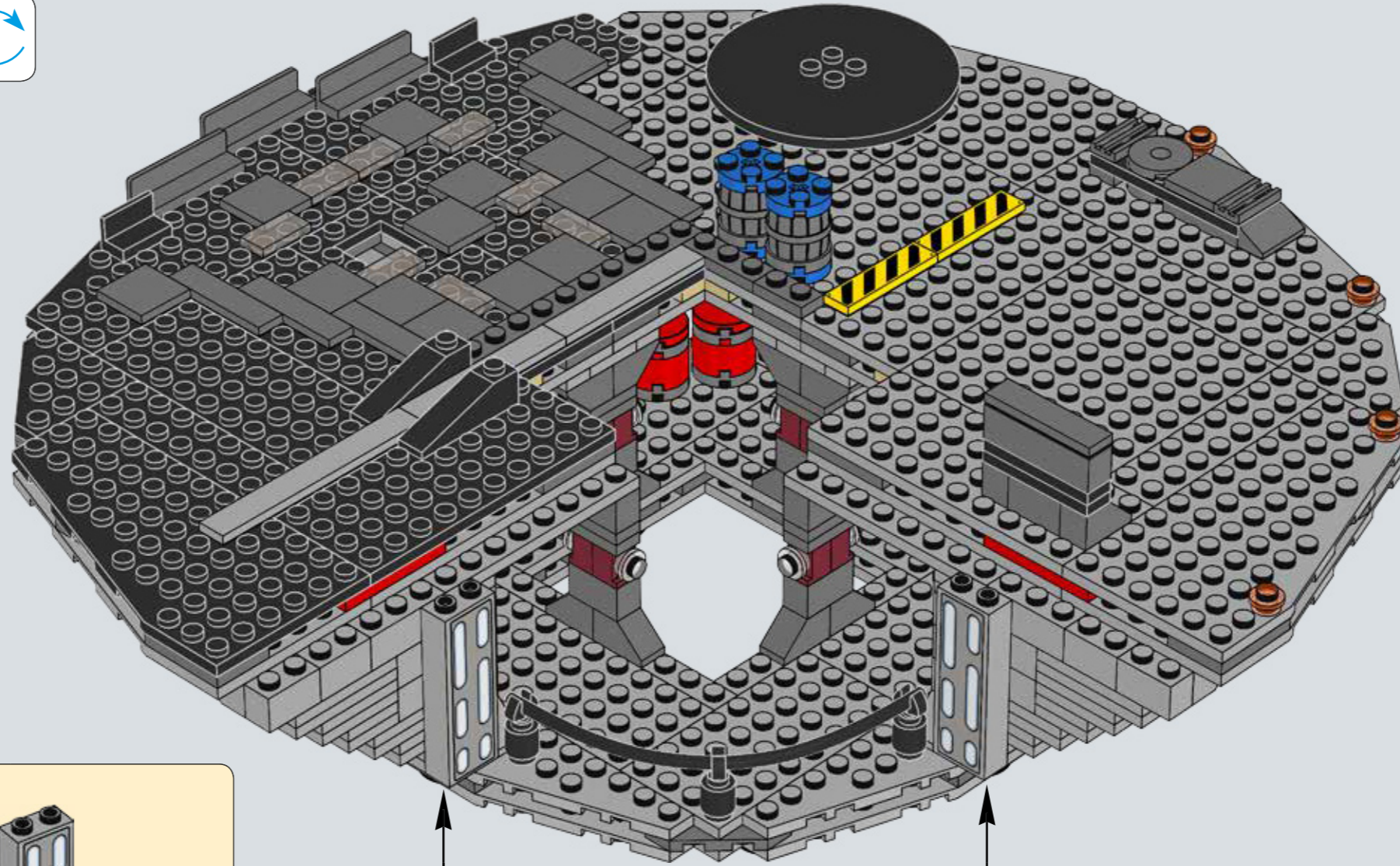

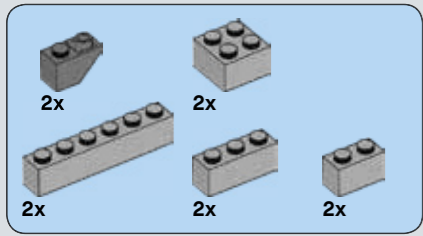

# 55

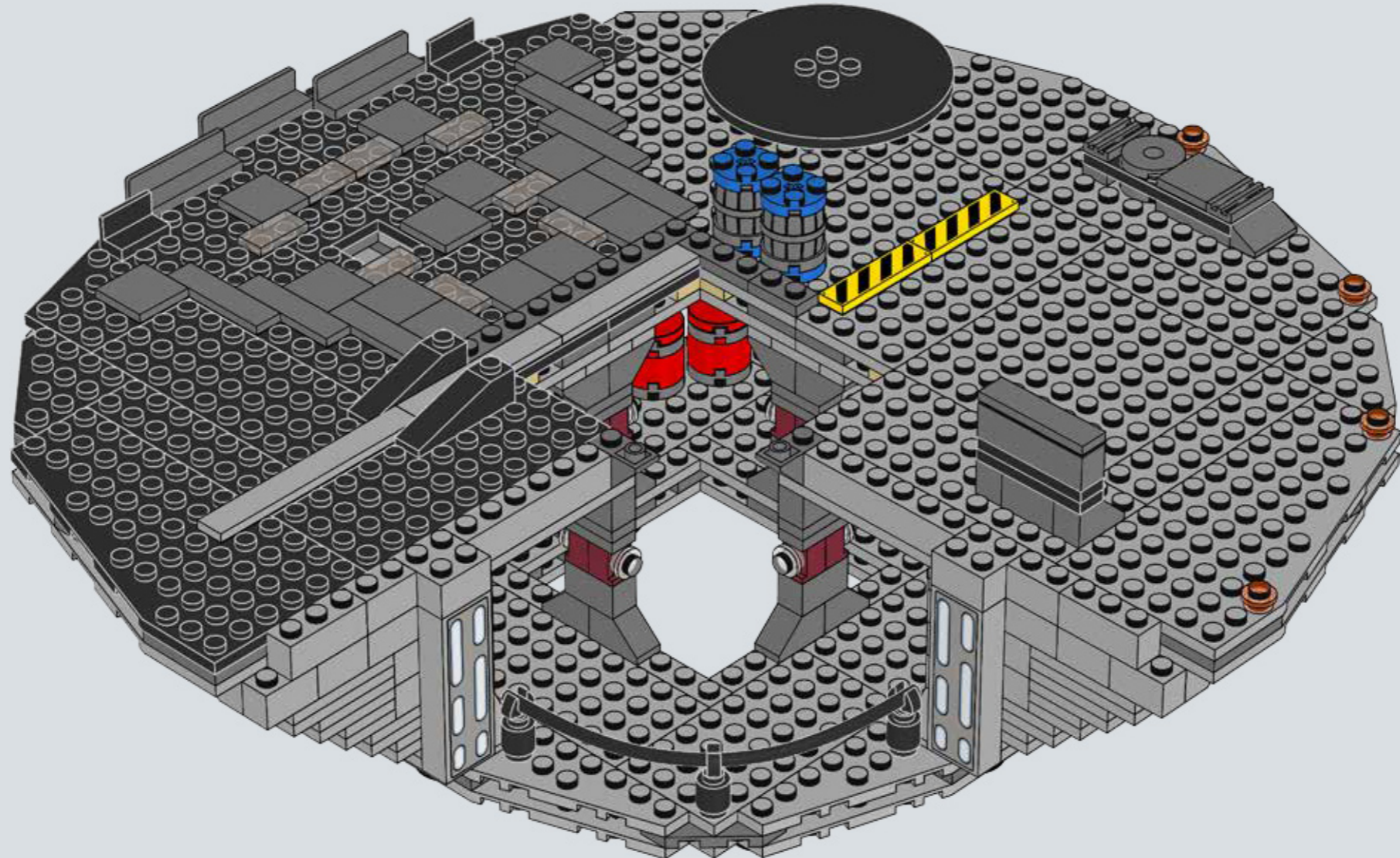

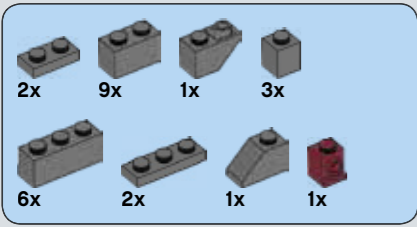

# 56

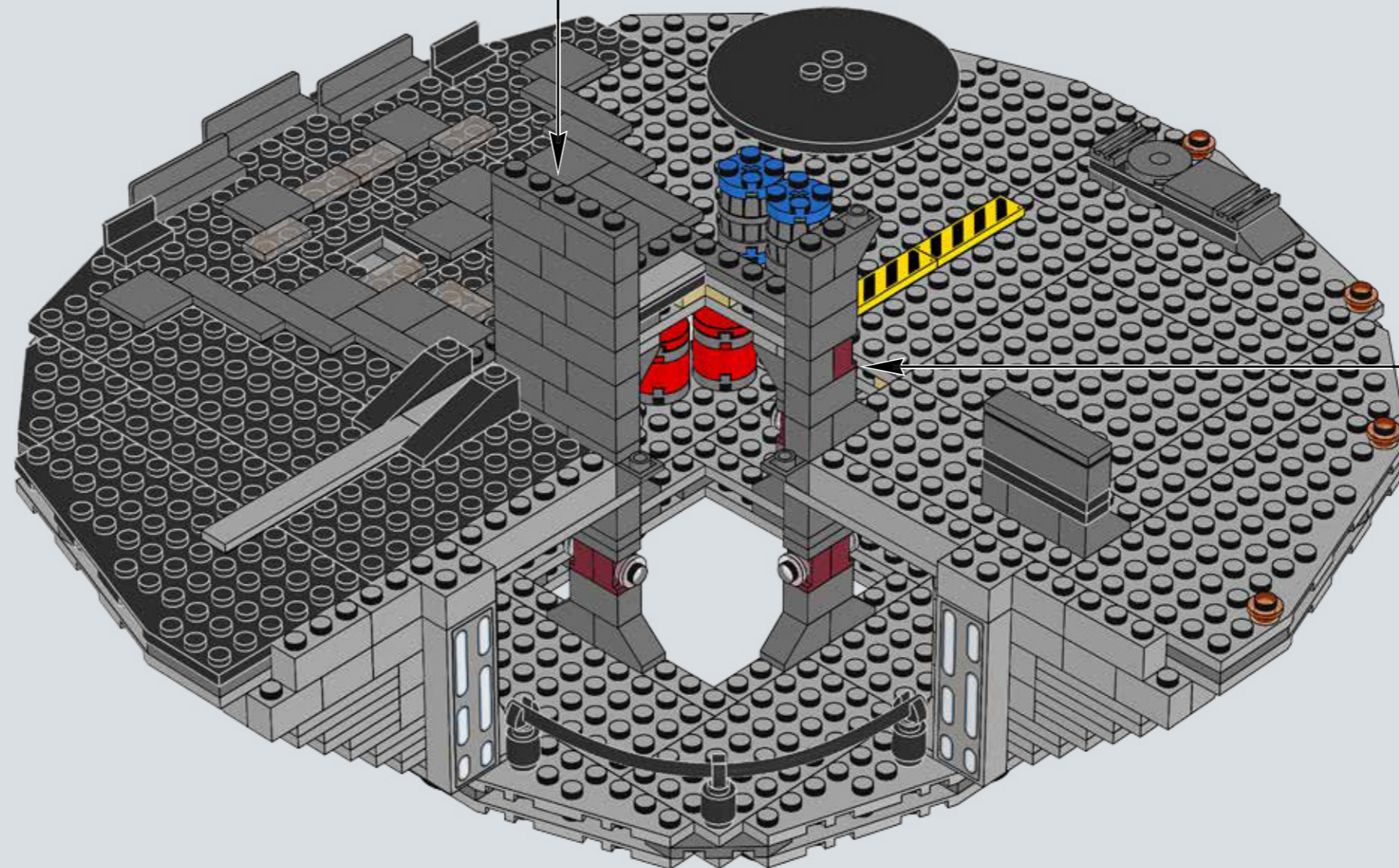
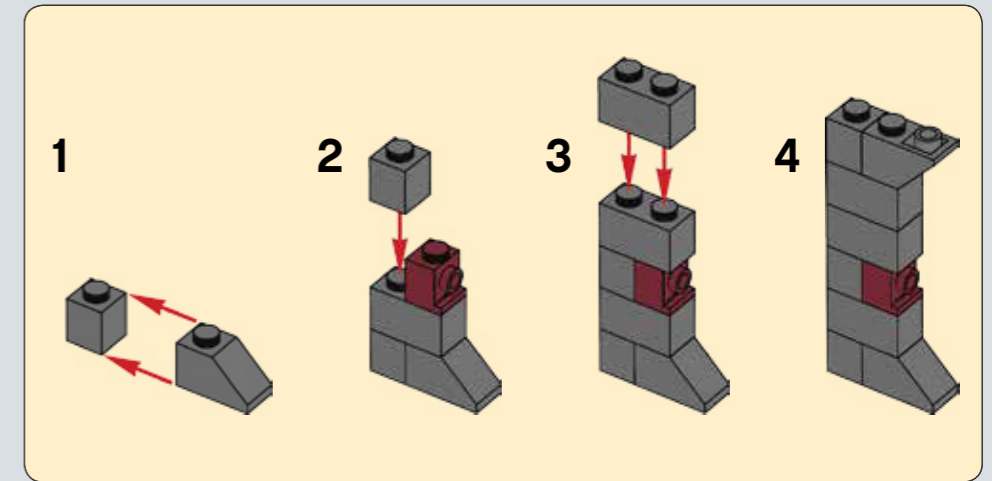
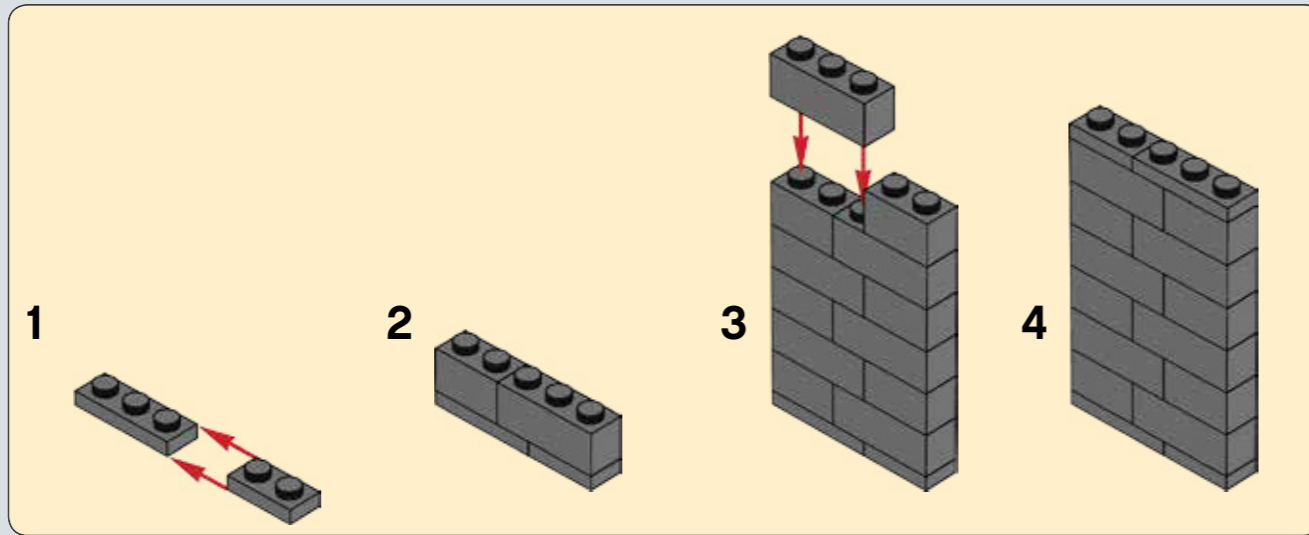

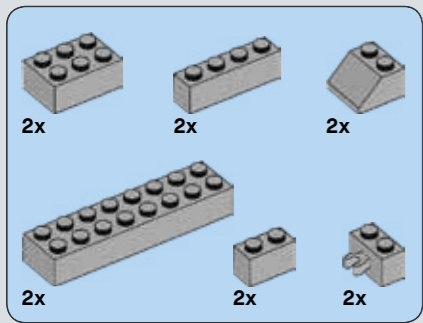

# 57

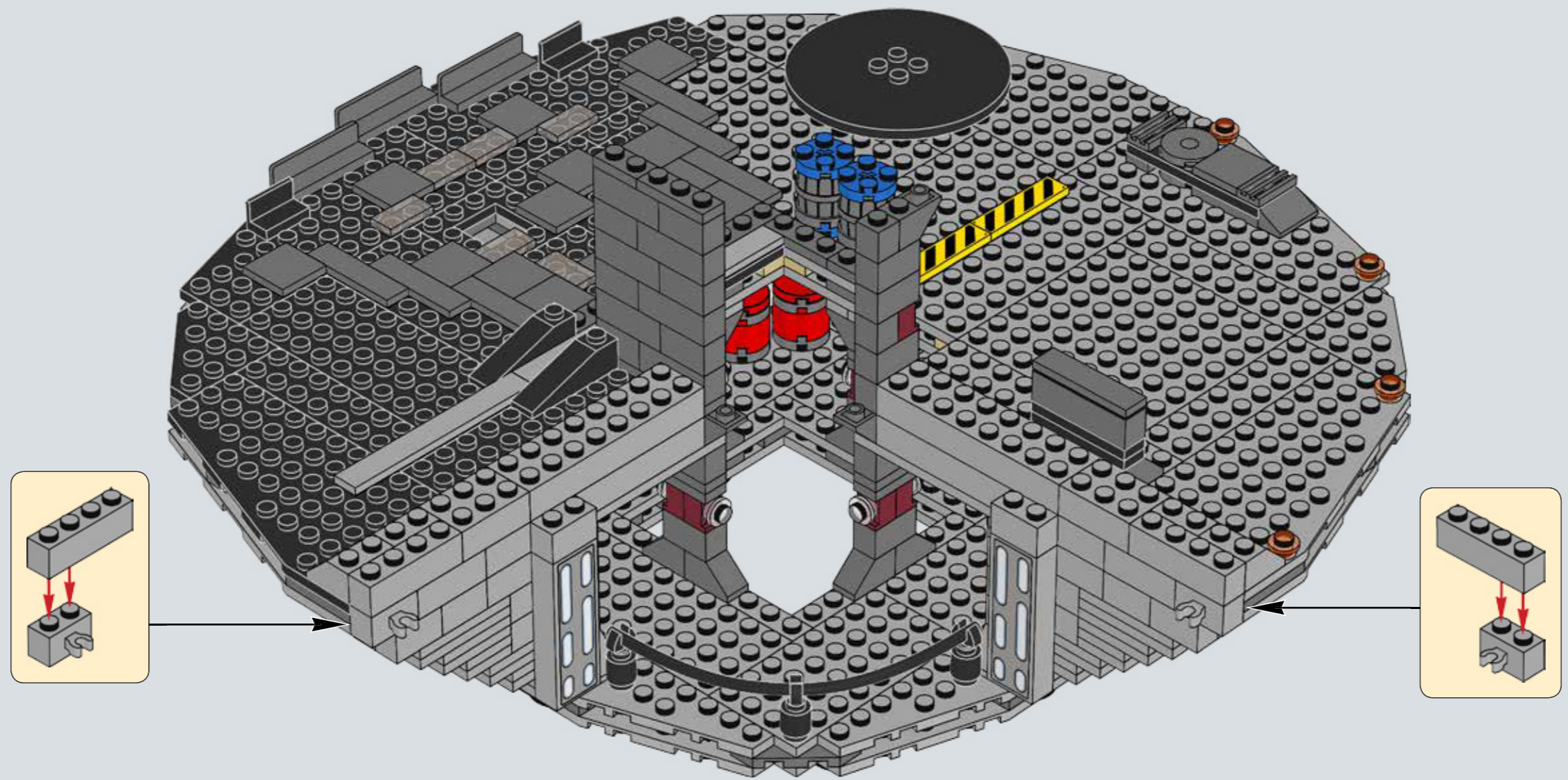

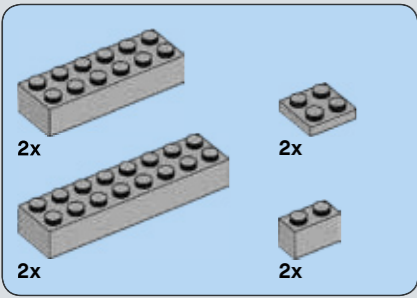

58

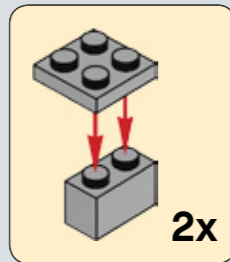
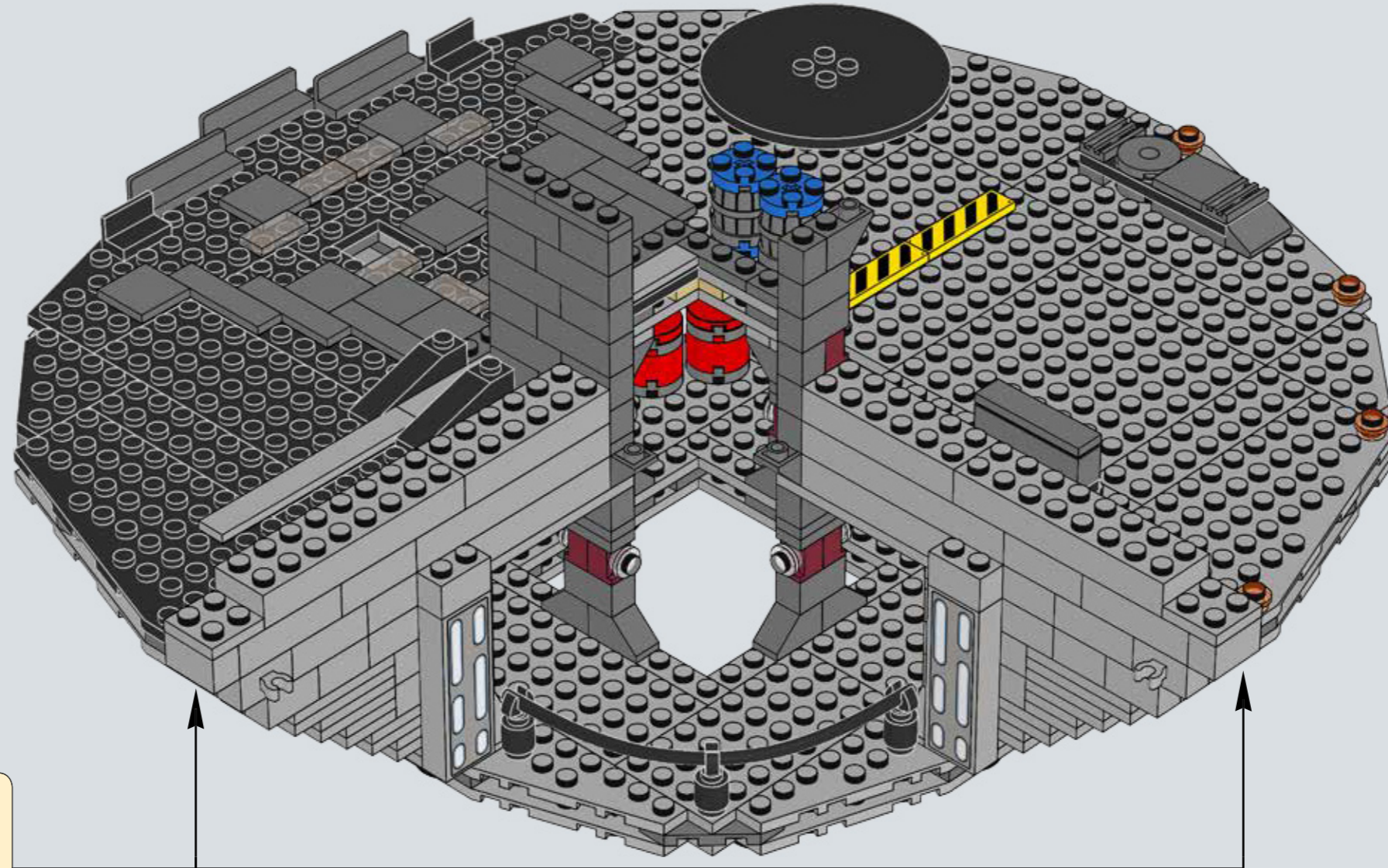

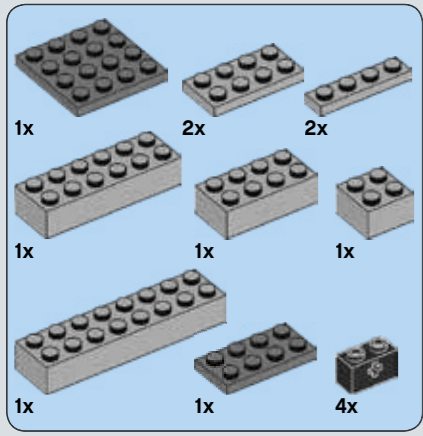

# 59

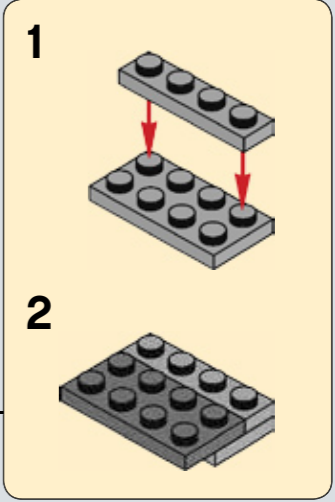
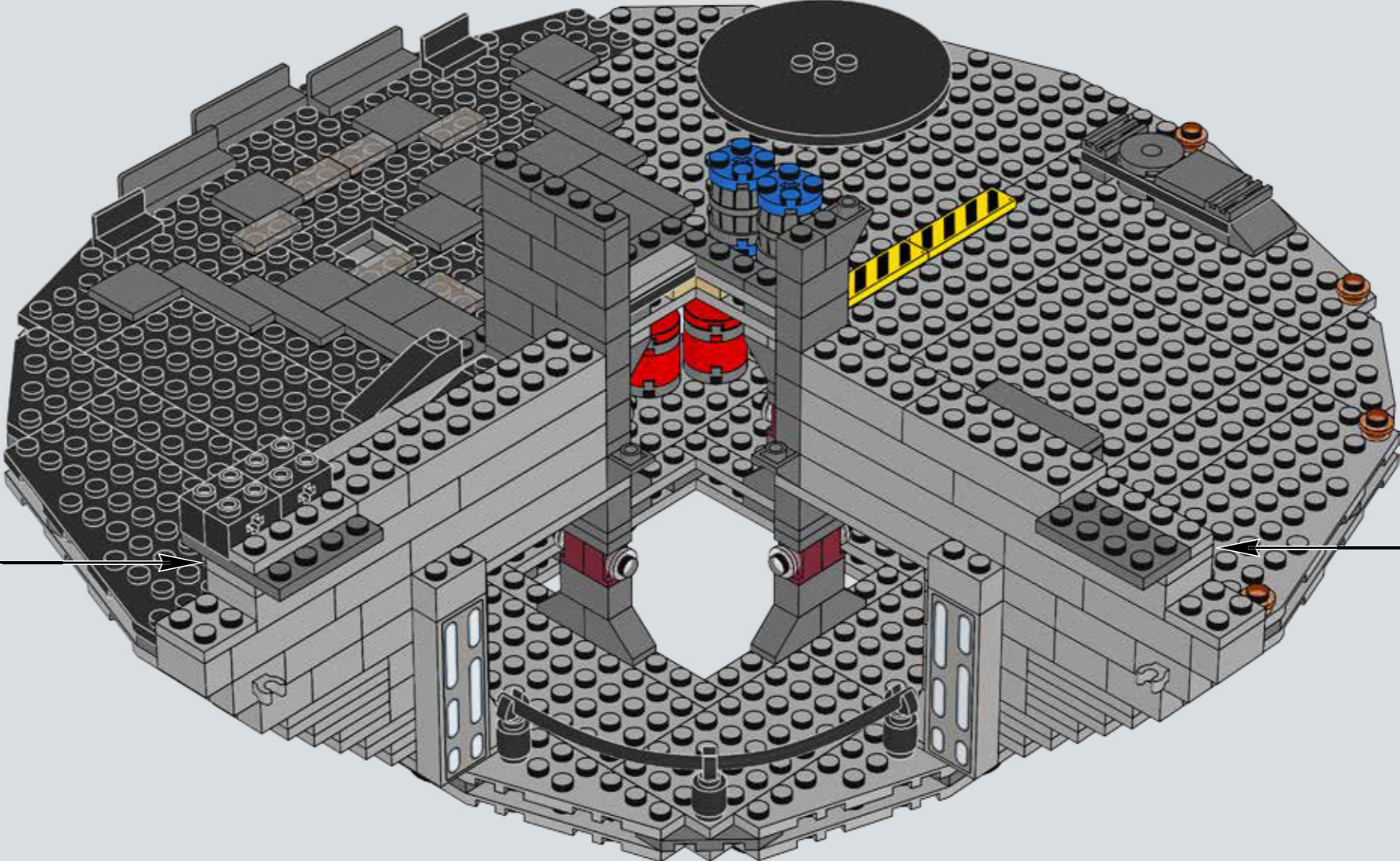
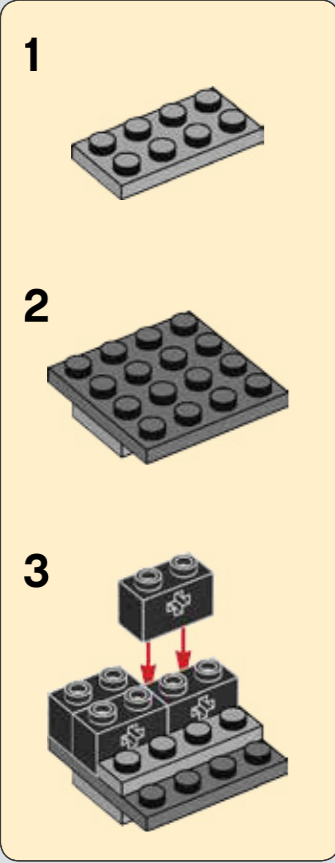

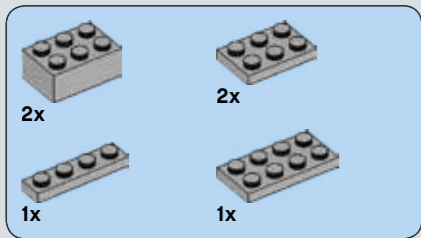

60

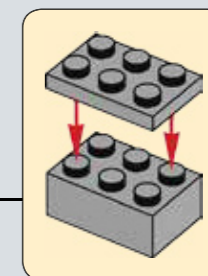
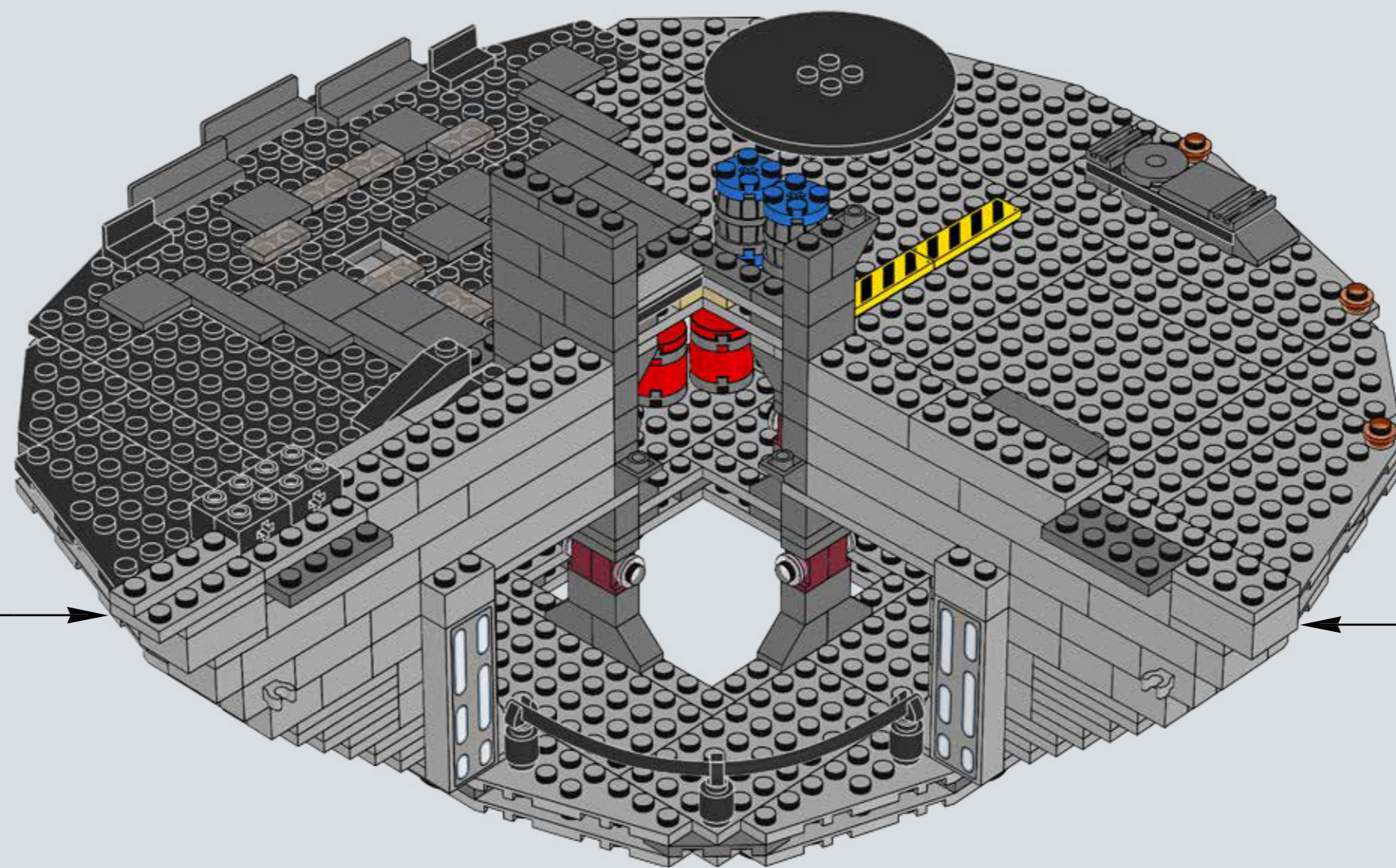
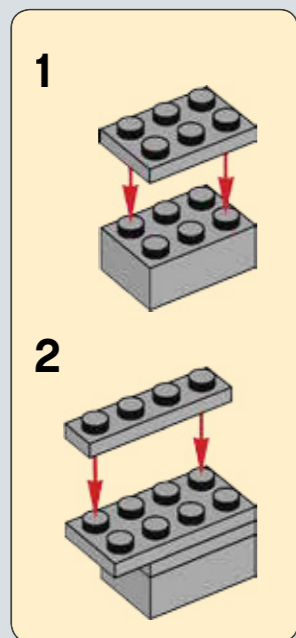

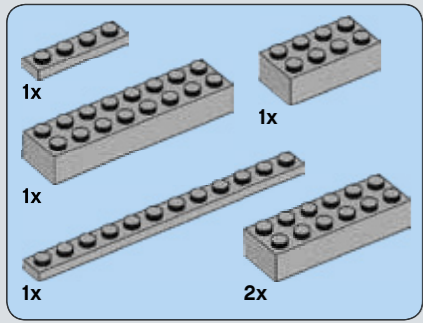

61

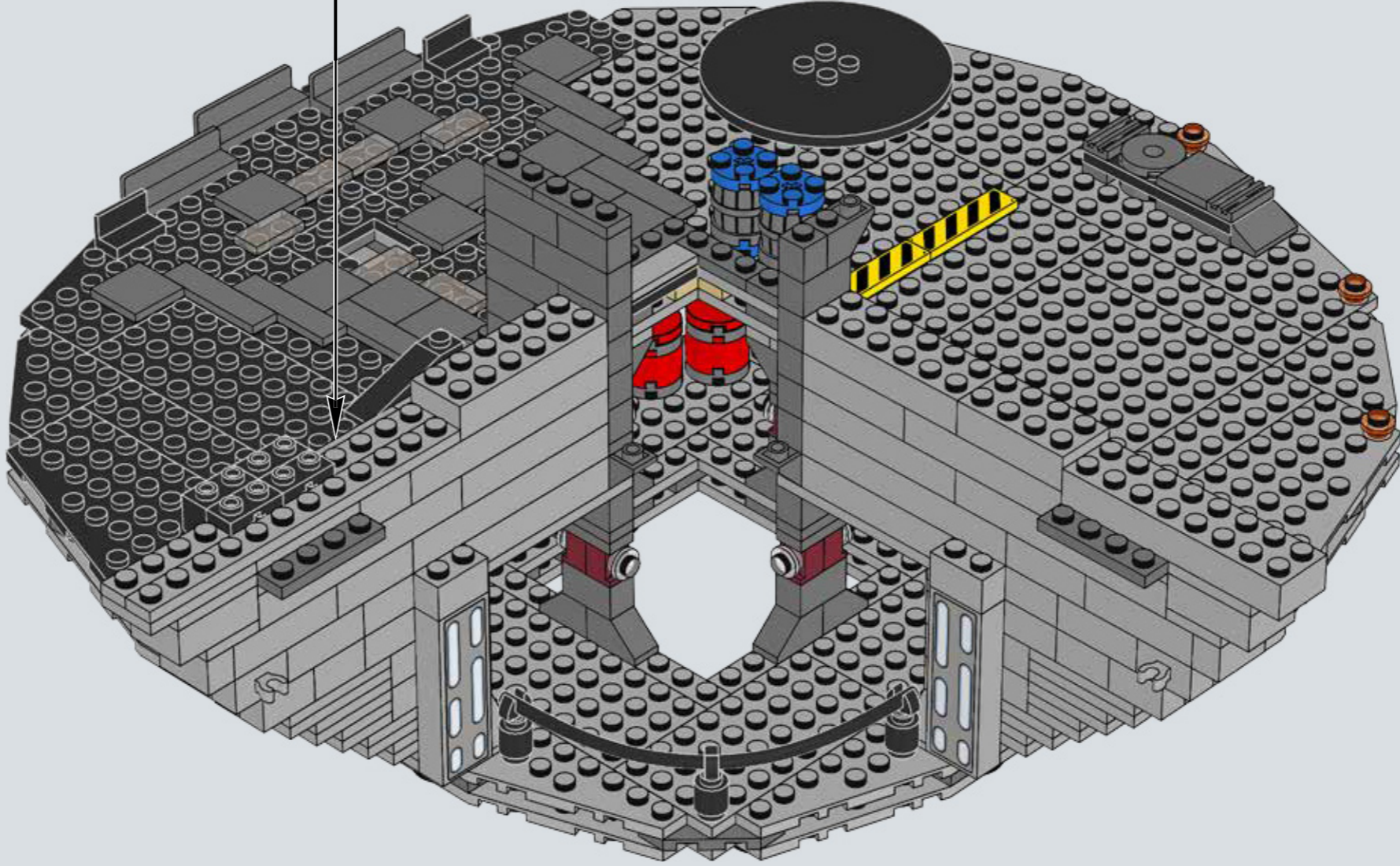
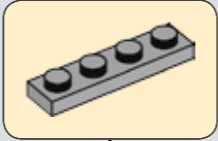



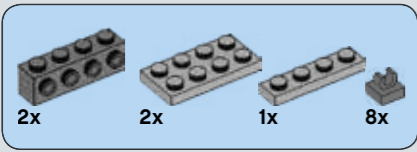

62

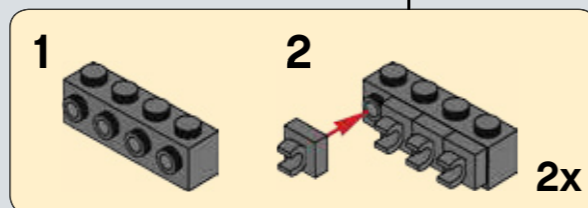
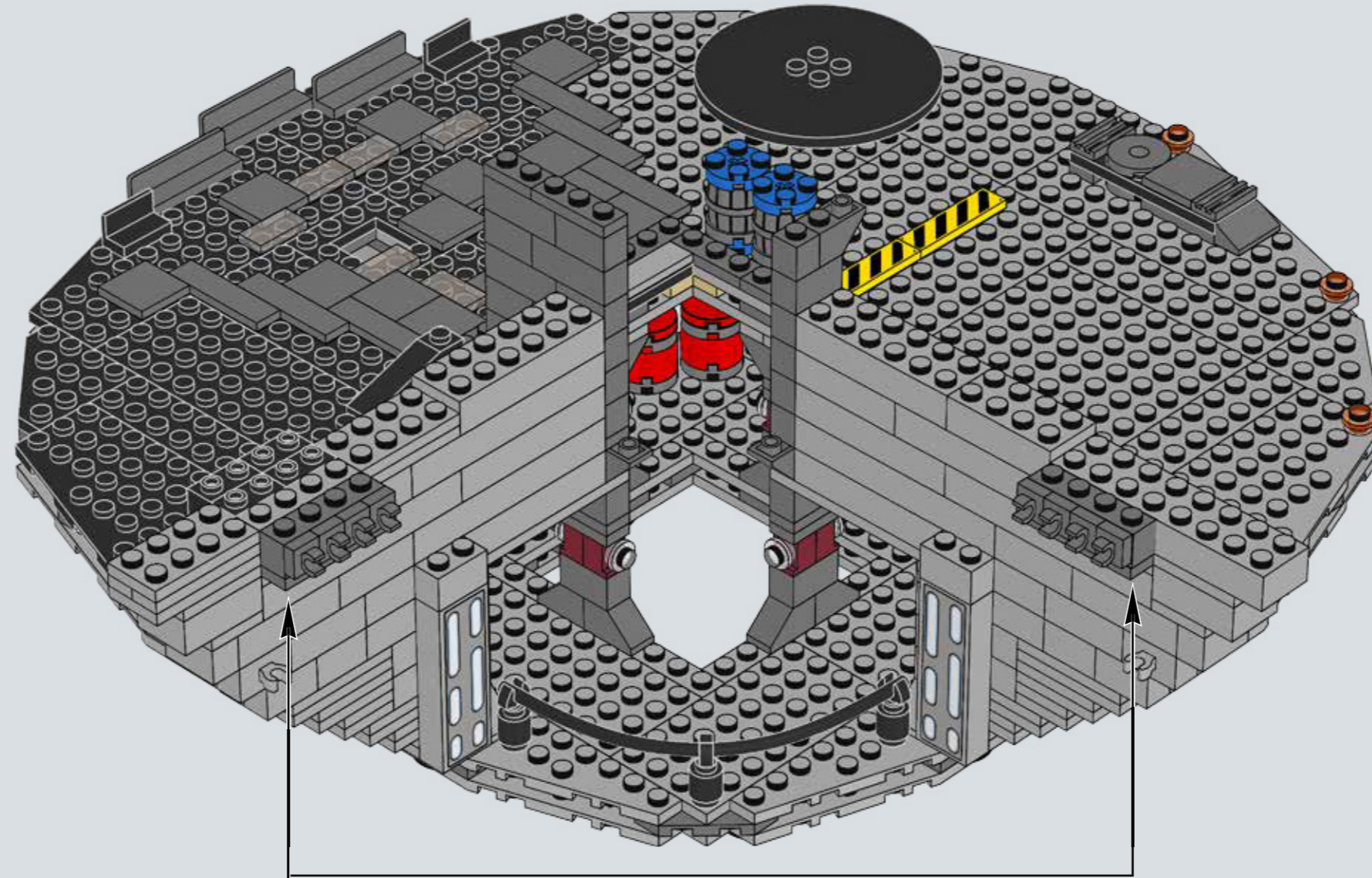

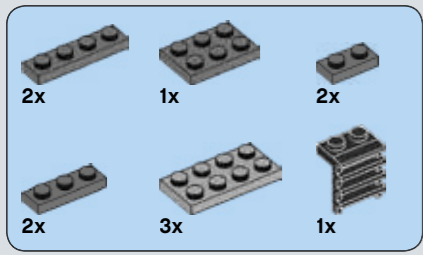

# 63

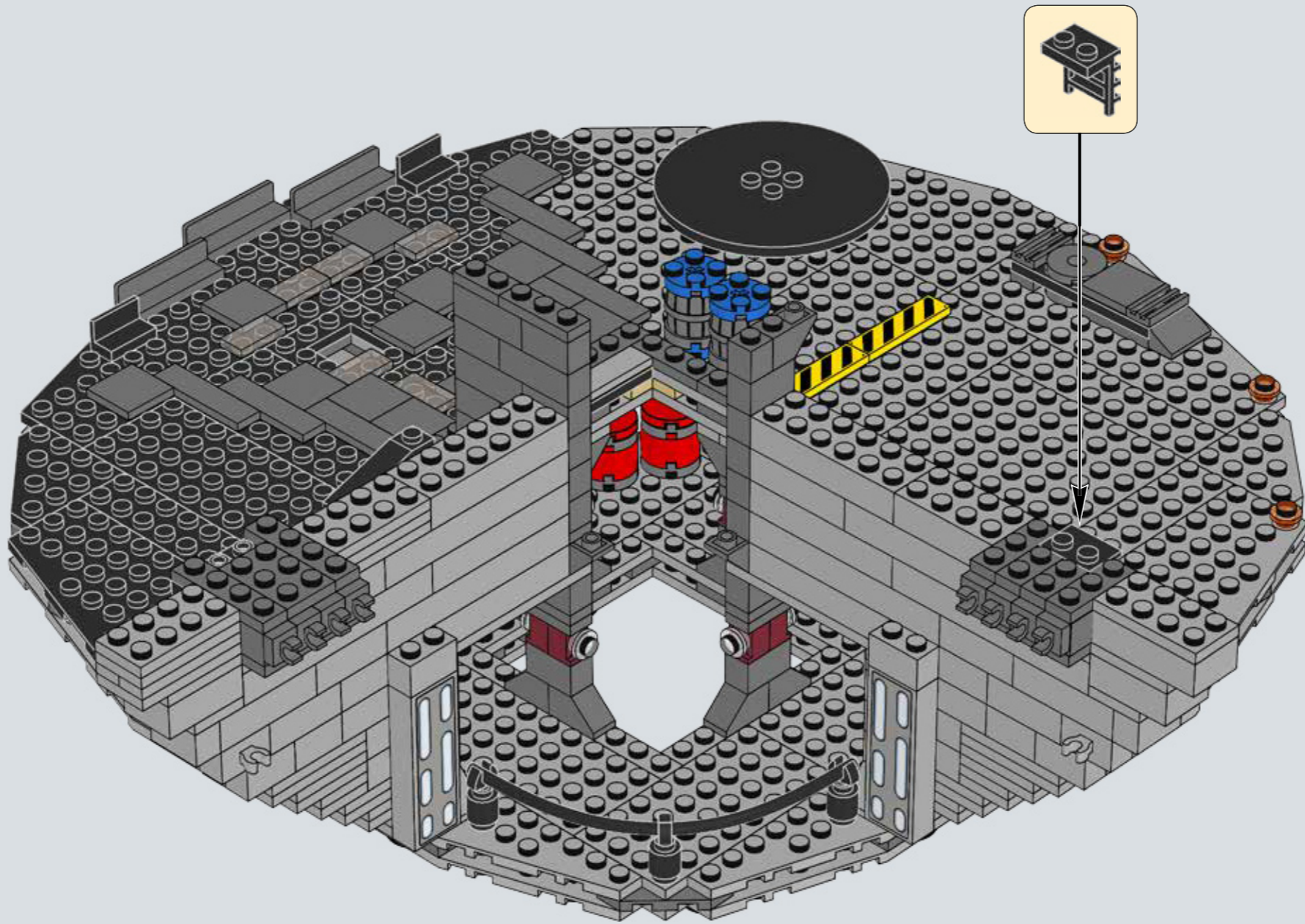

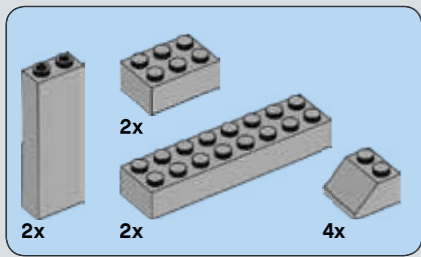

64

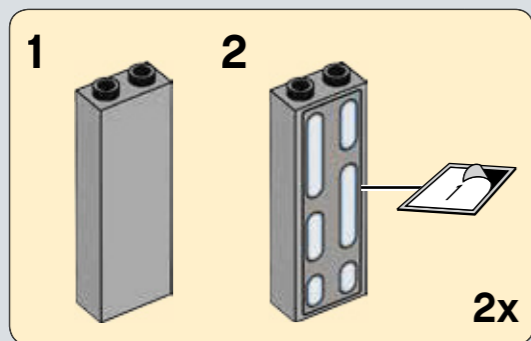
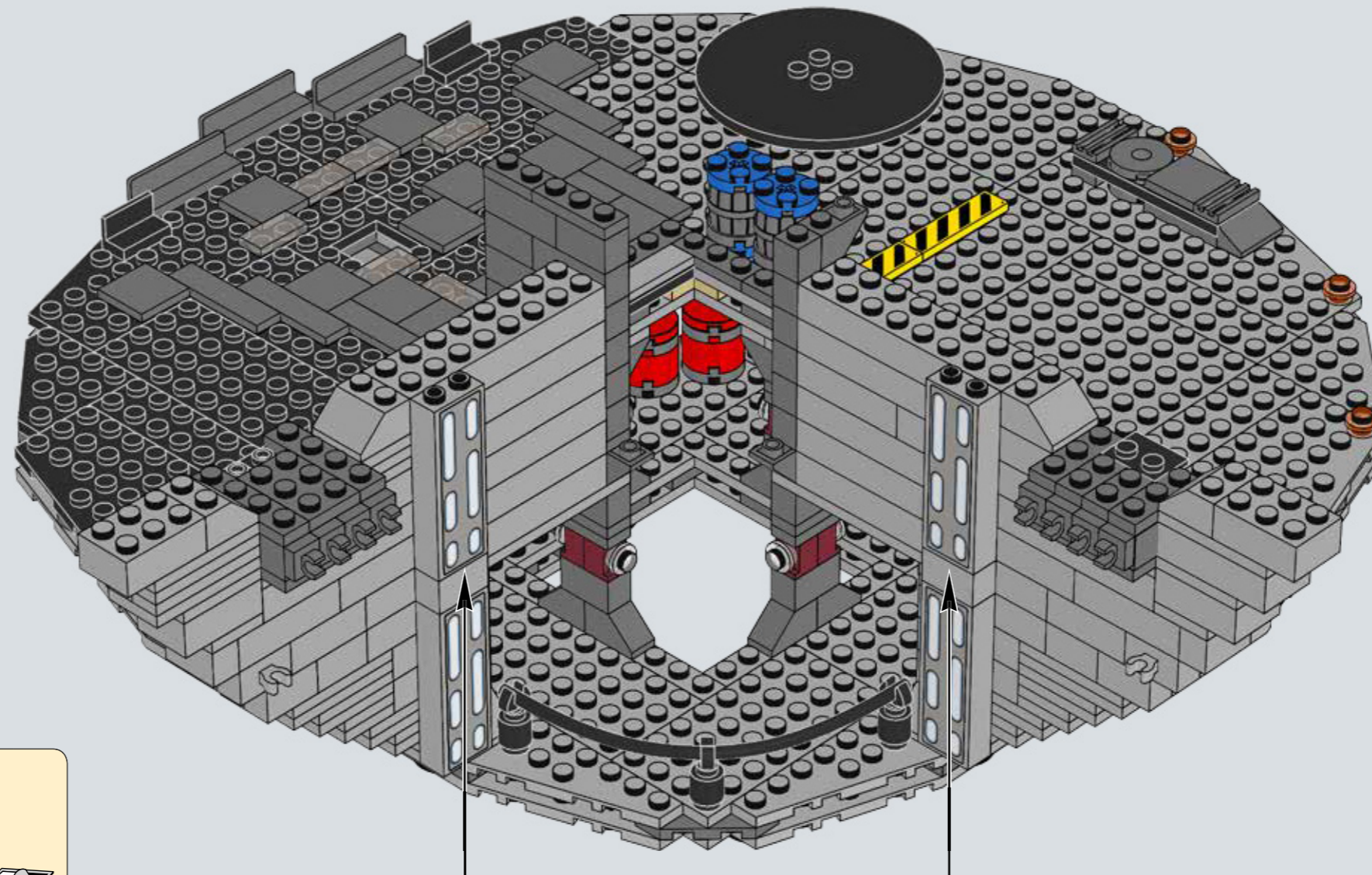

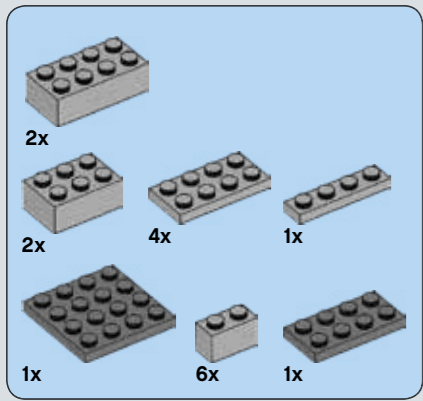

# 65

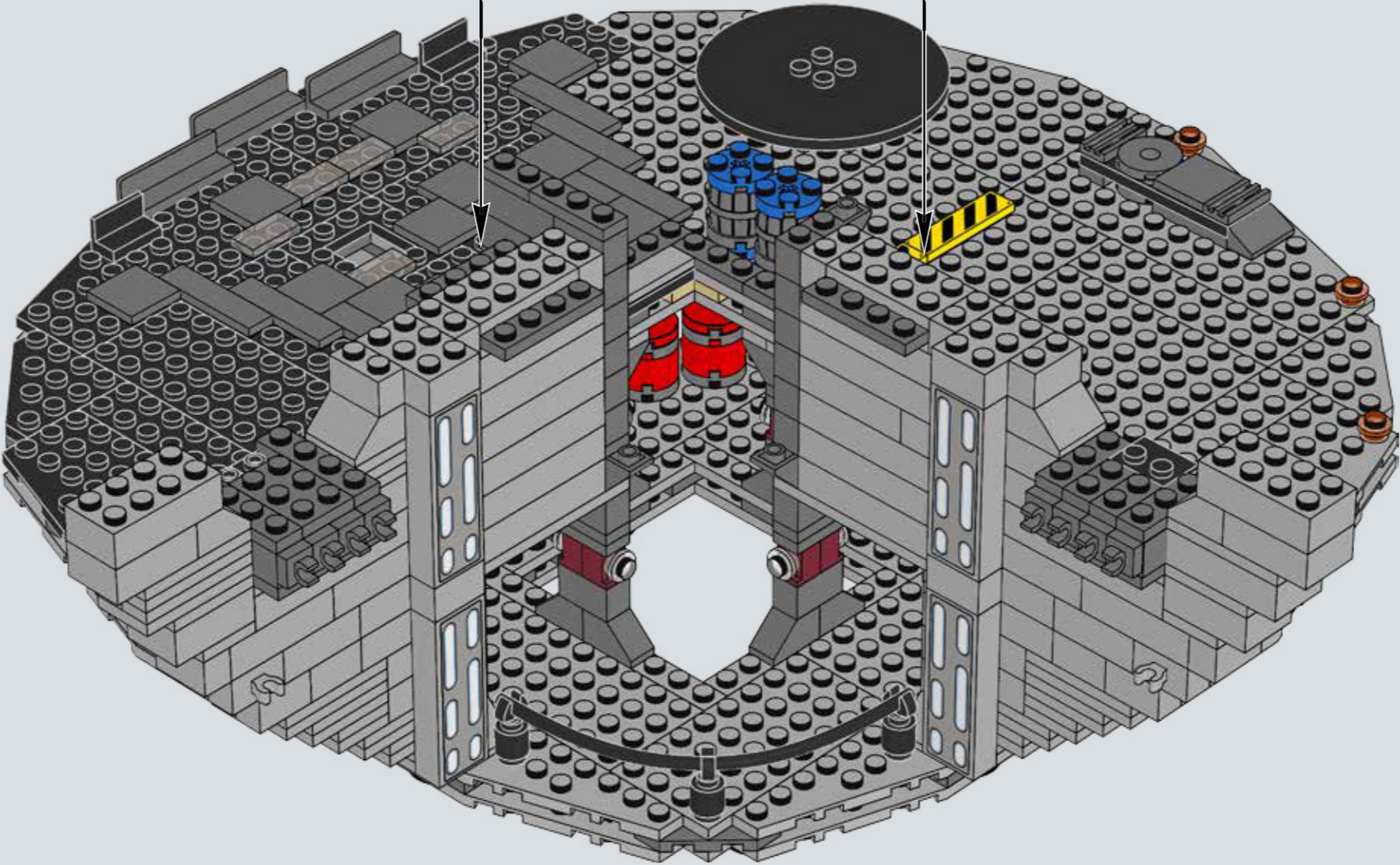
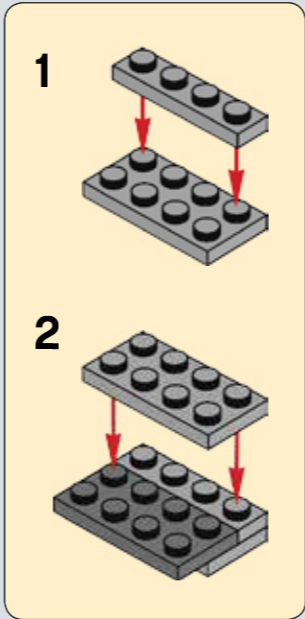
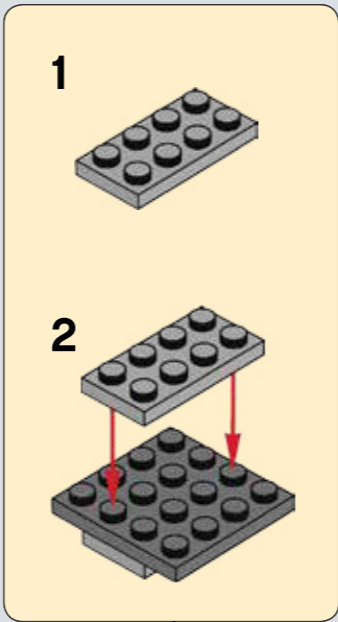

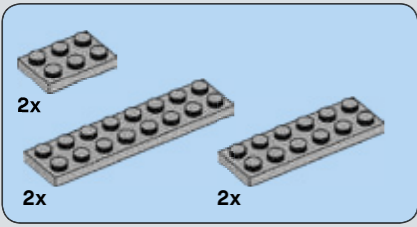

66

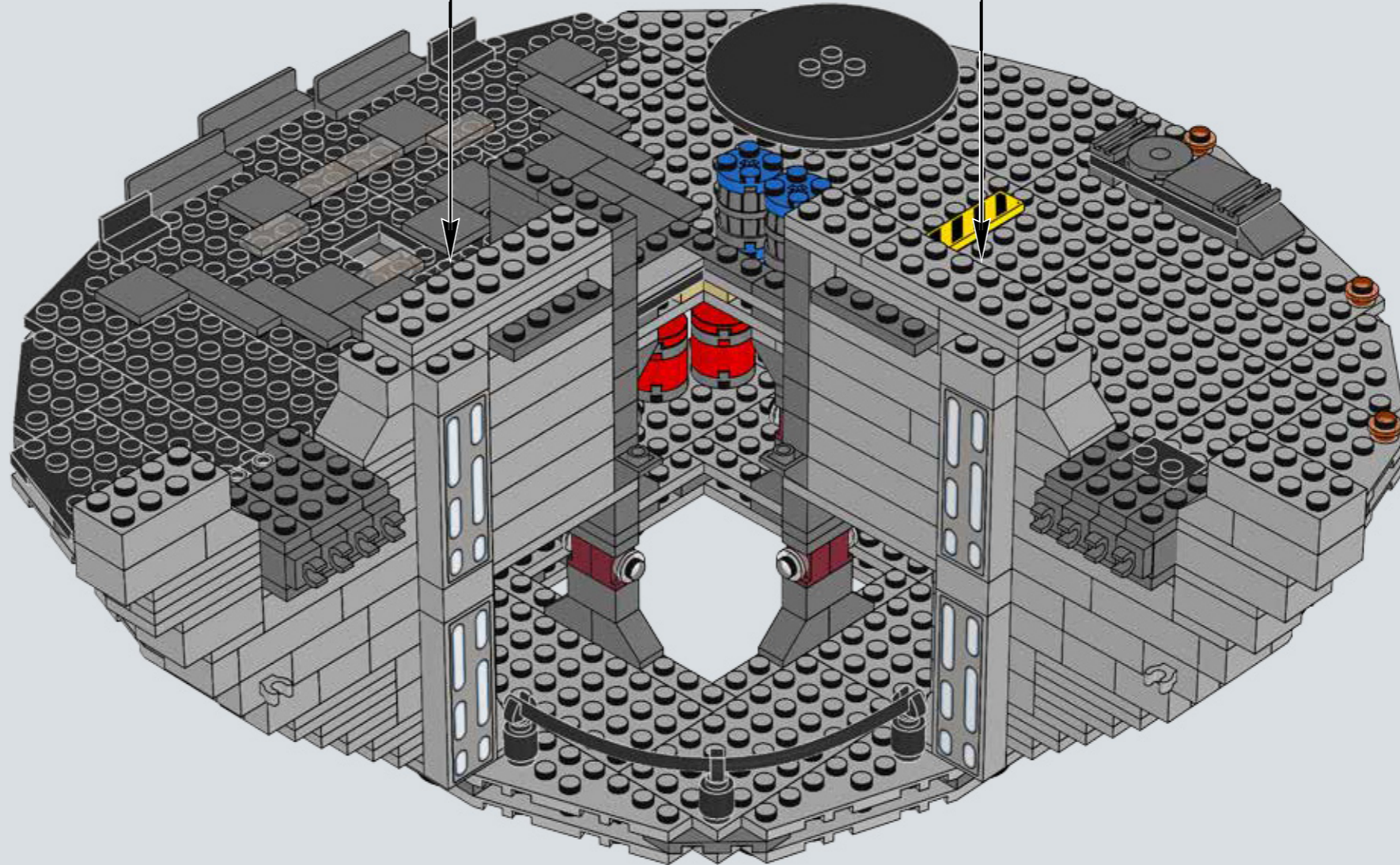
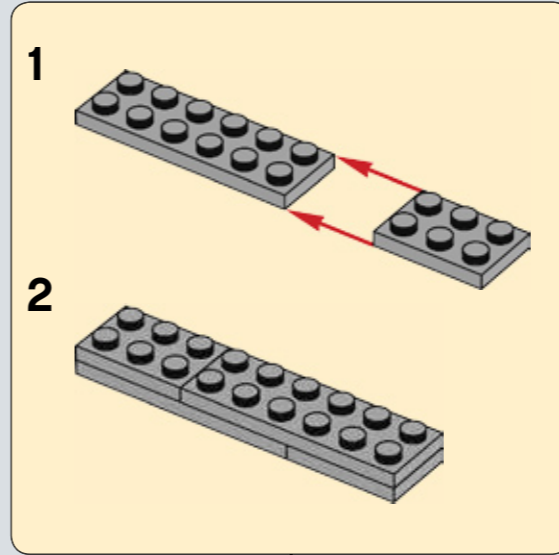
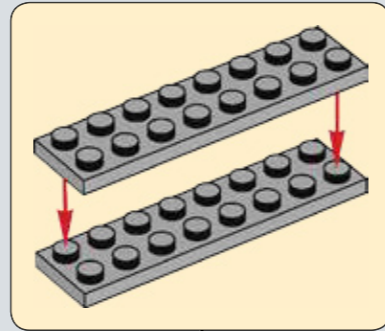

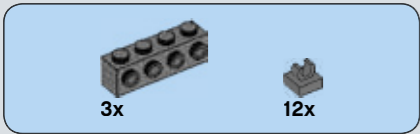

# 67

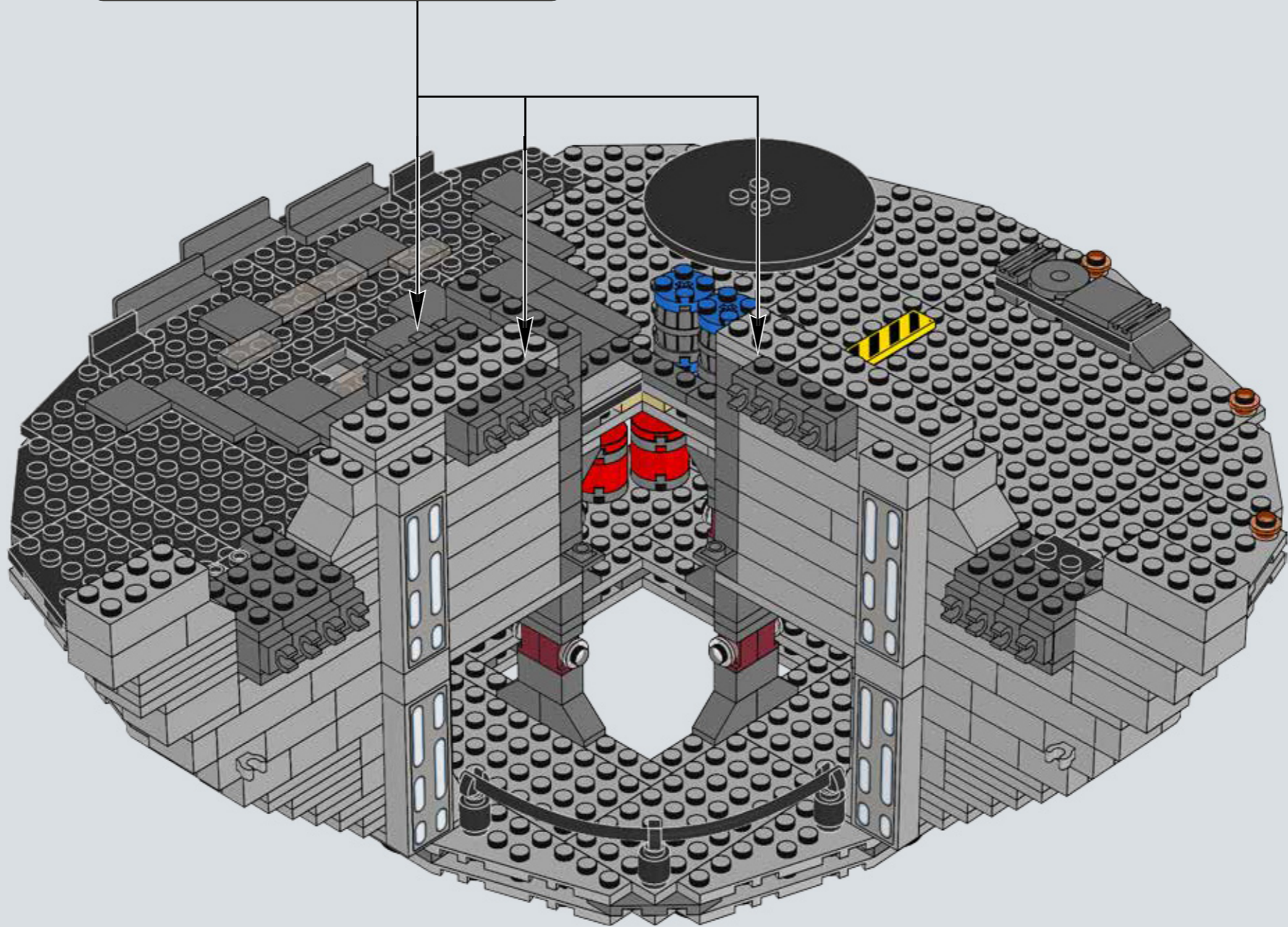
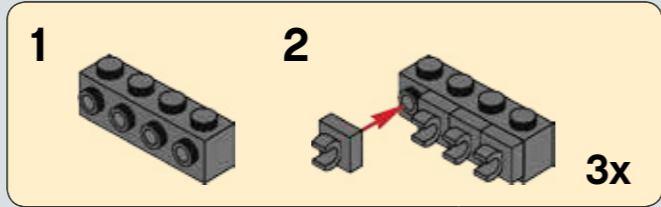

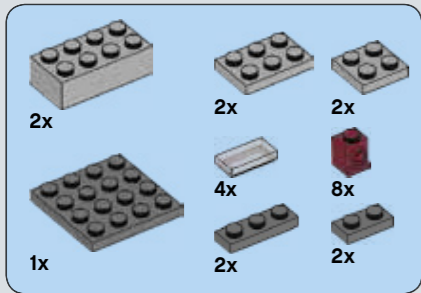

68

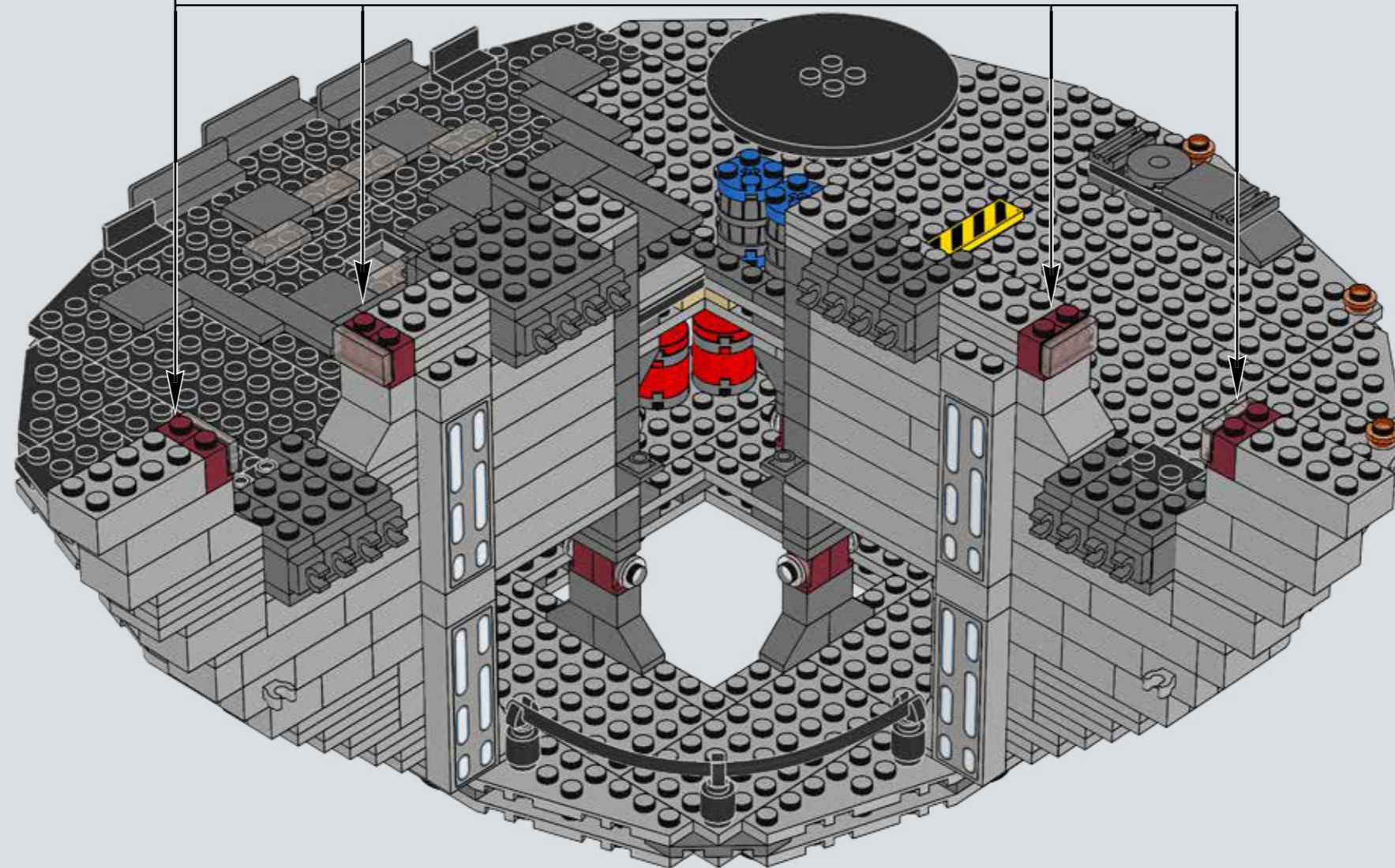
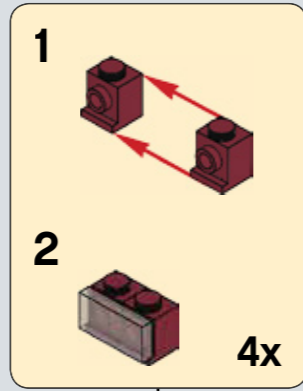

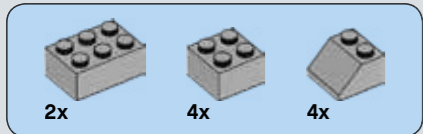

69

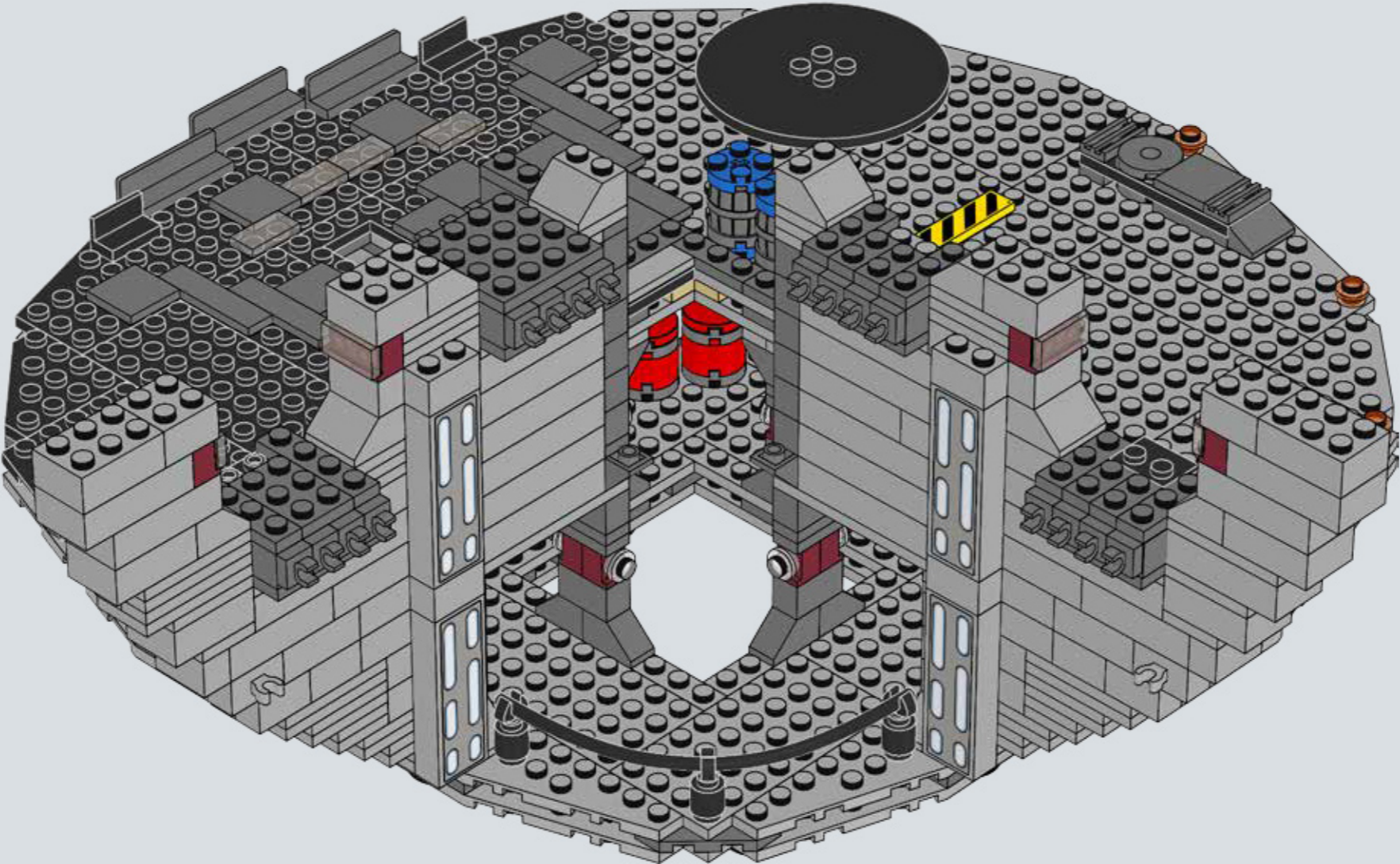



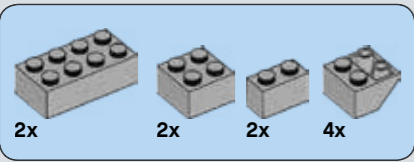

70

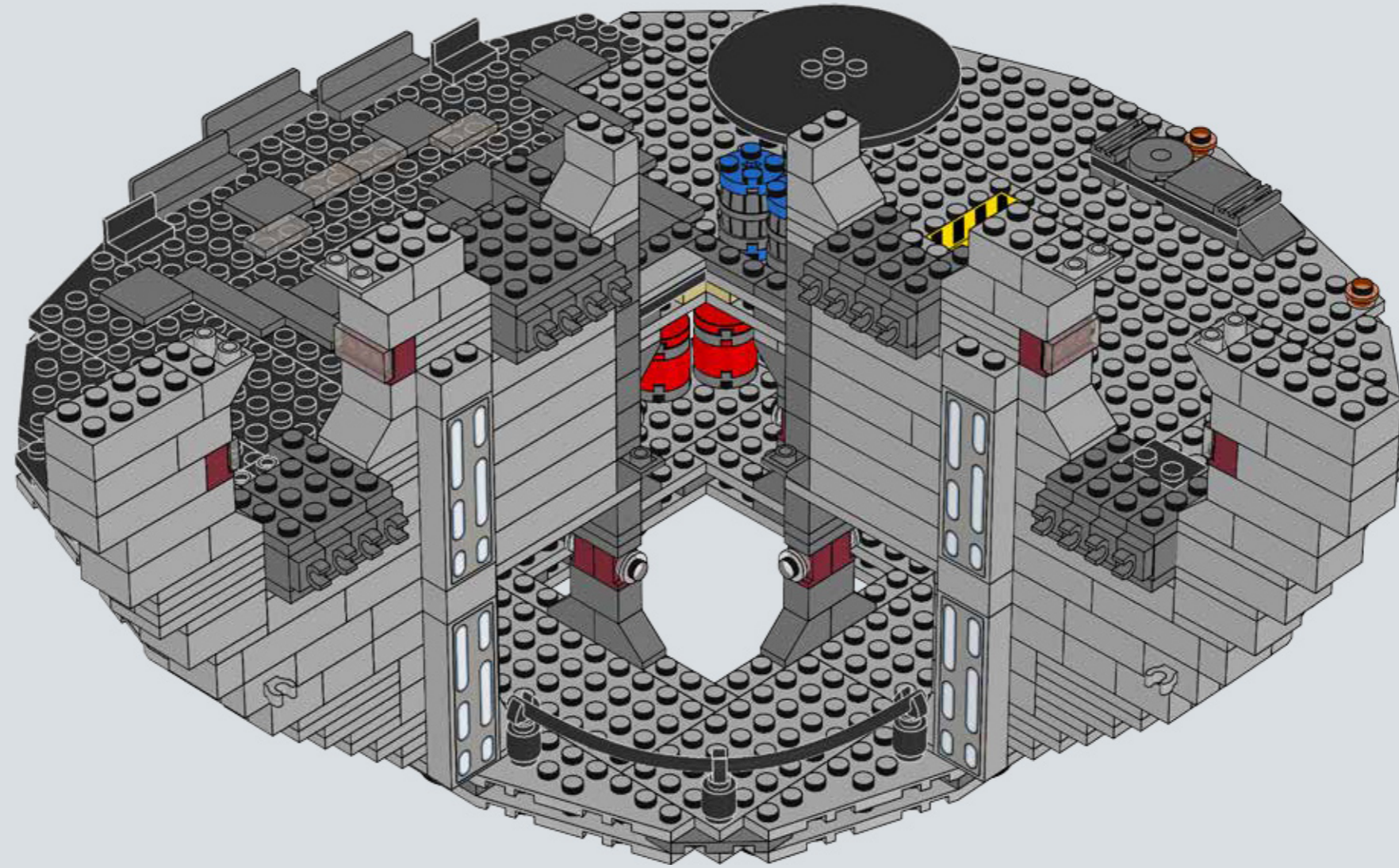

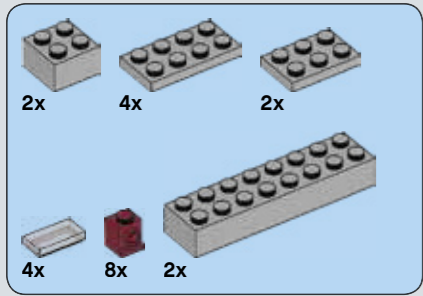

71

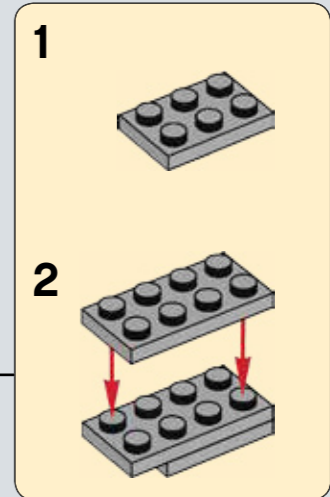
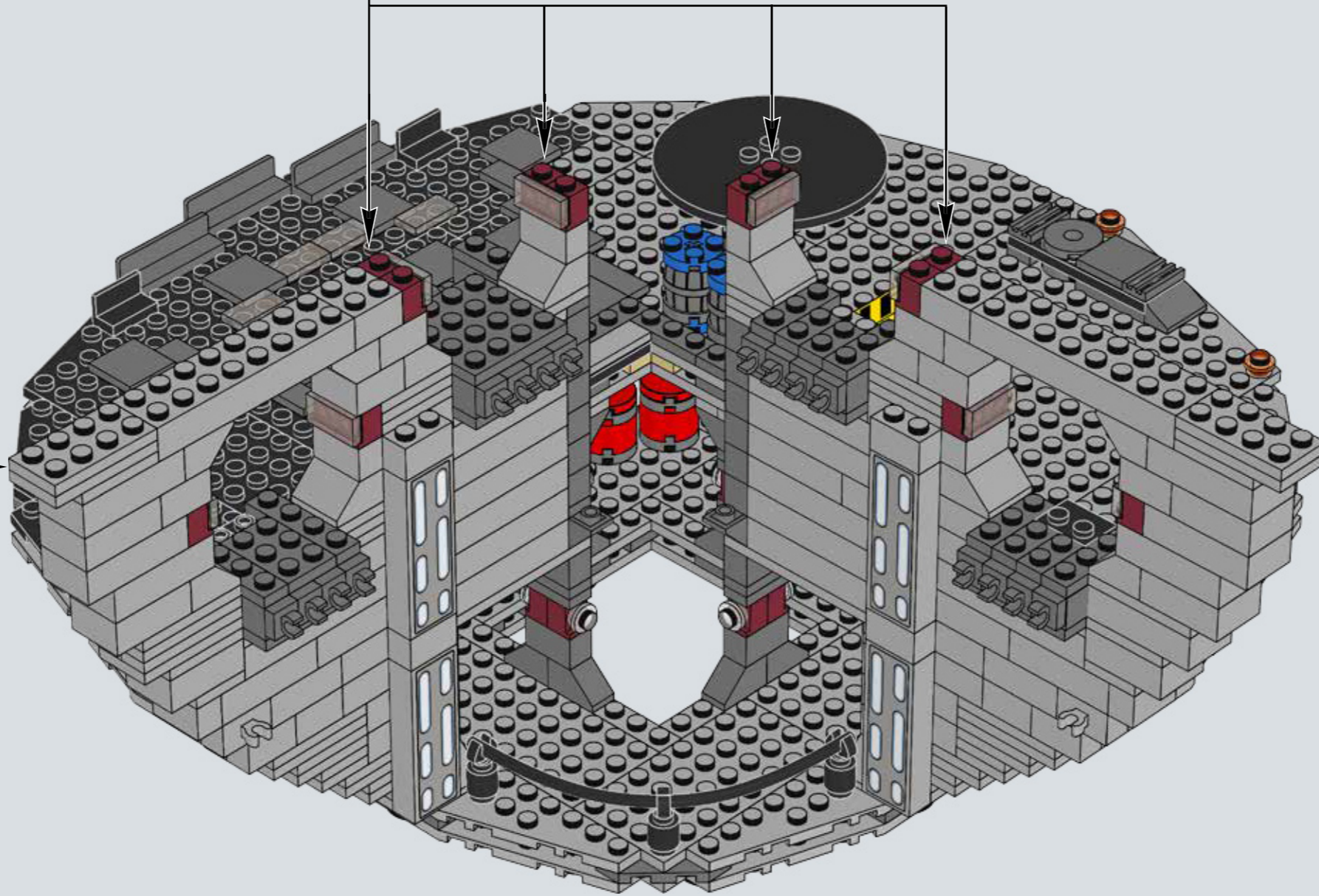
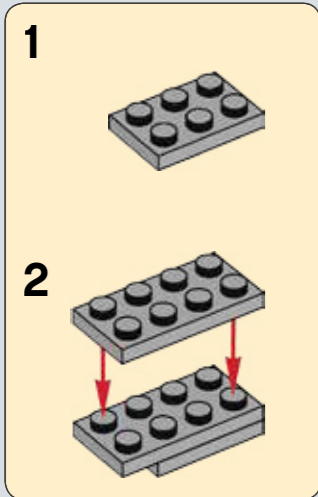
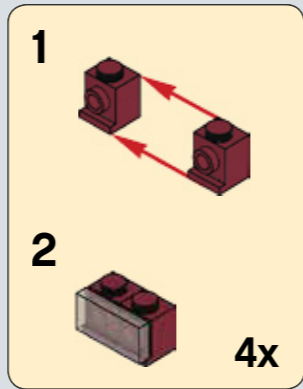

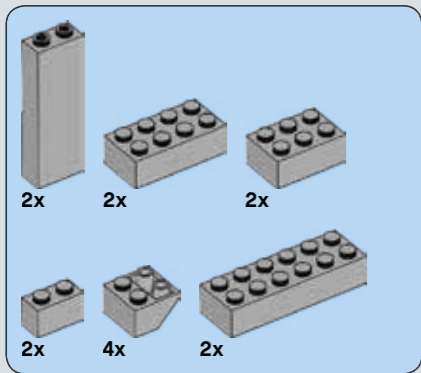

72

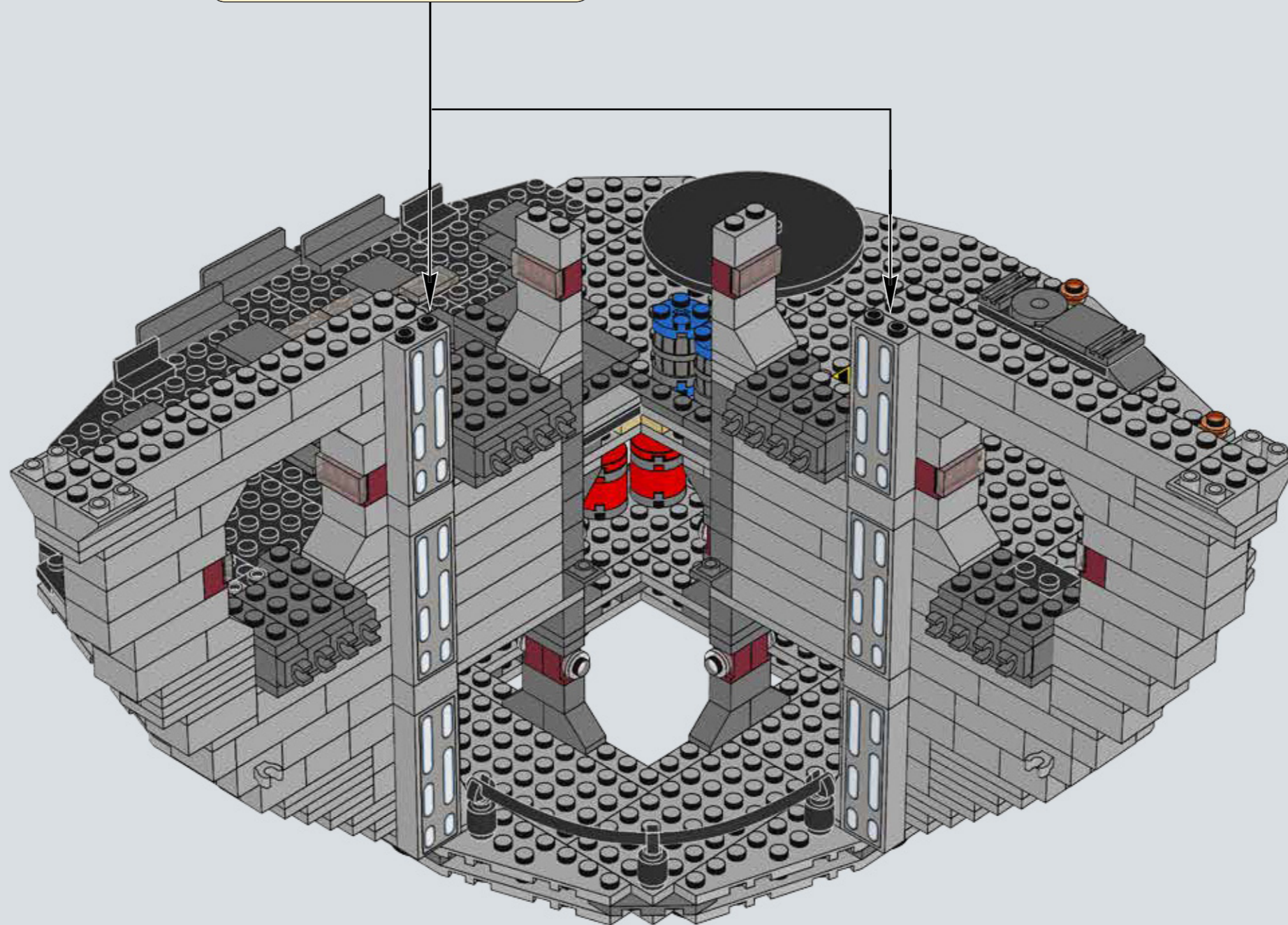
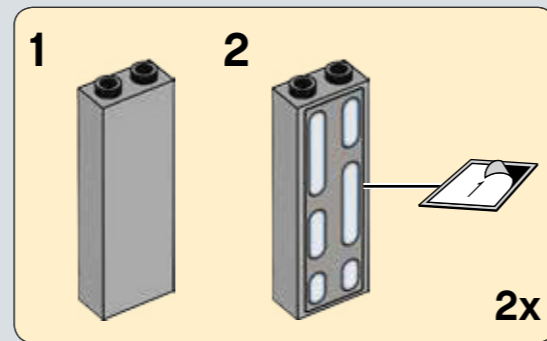

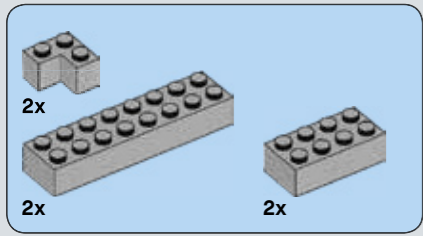

73

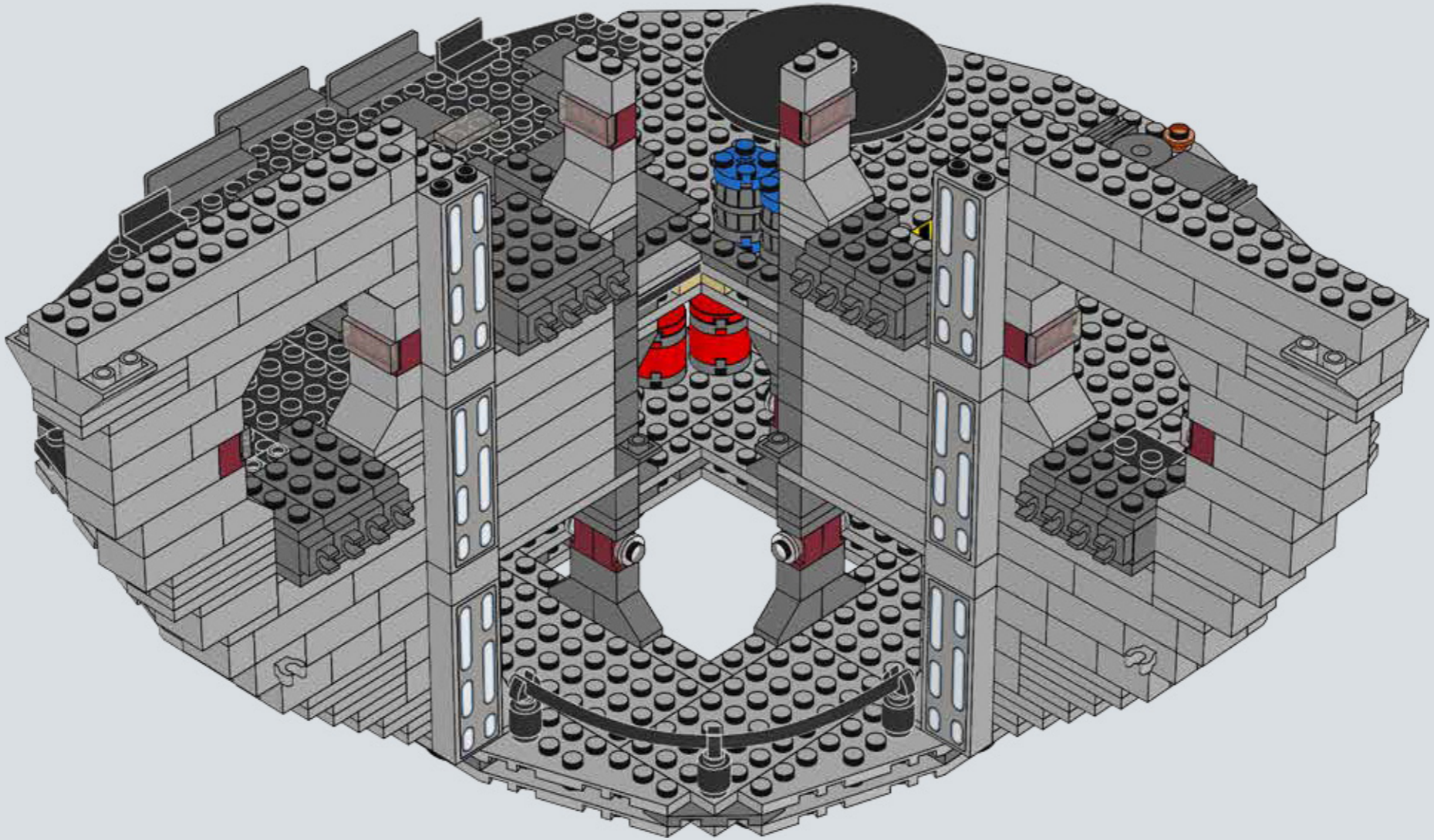

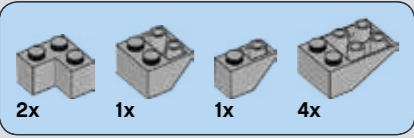

74

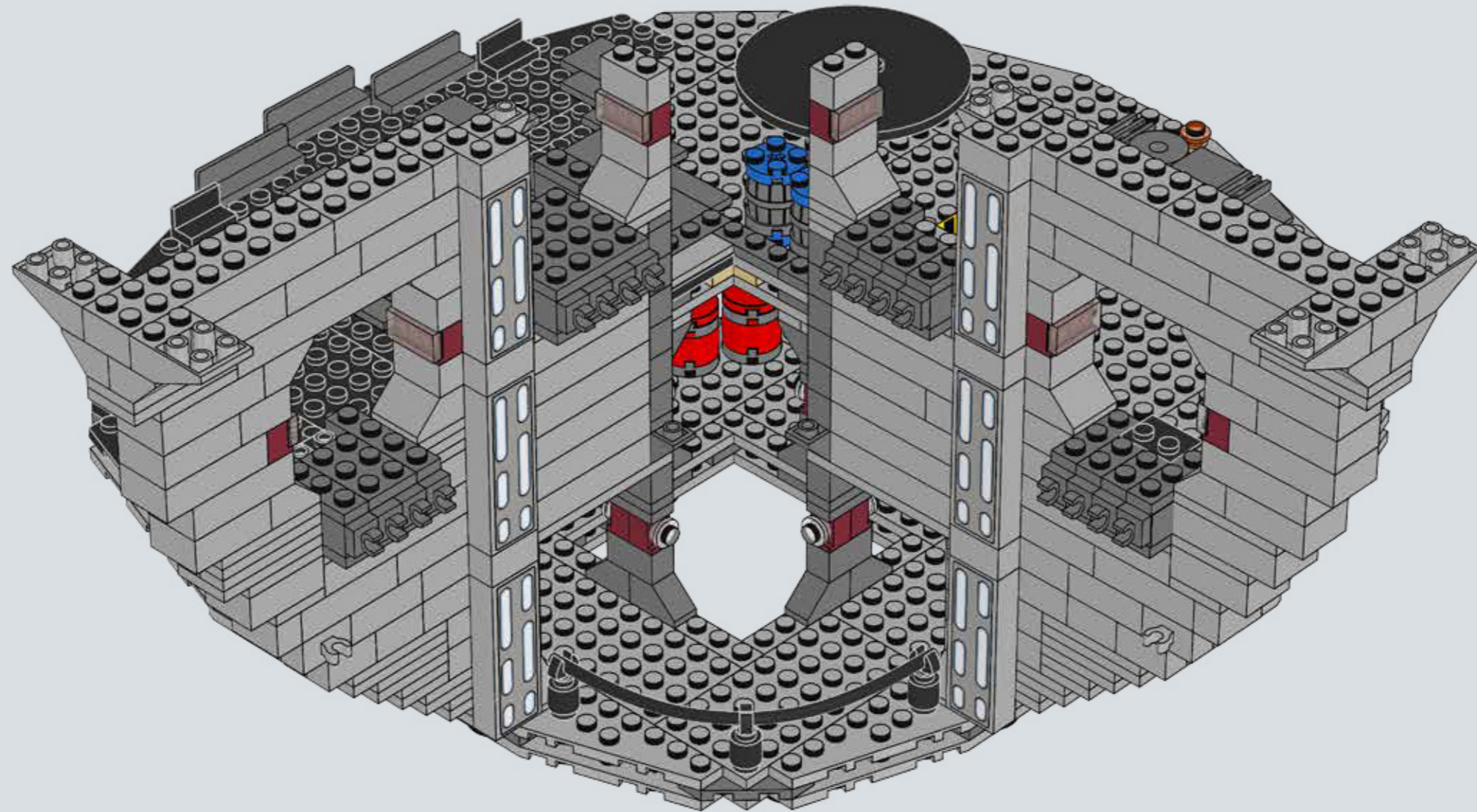

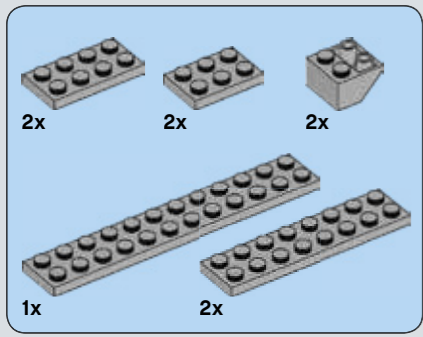

75

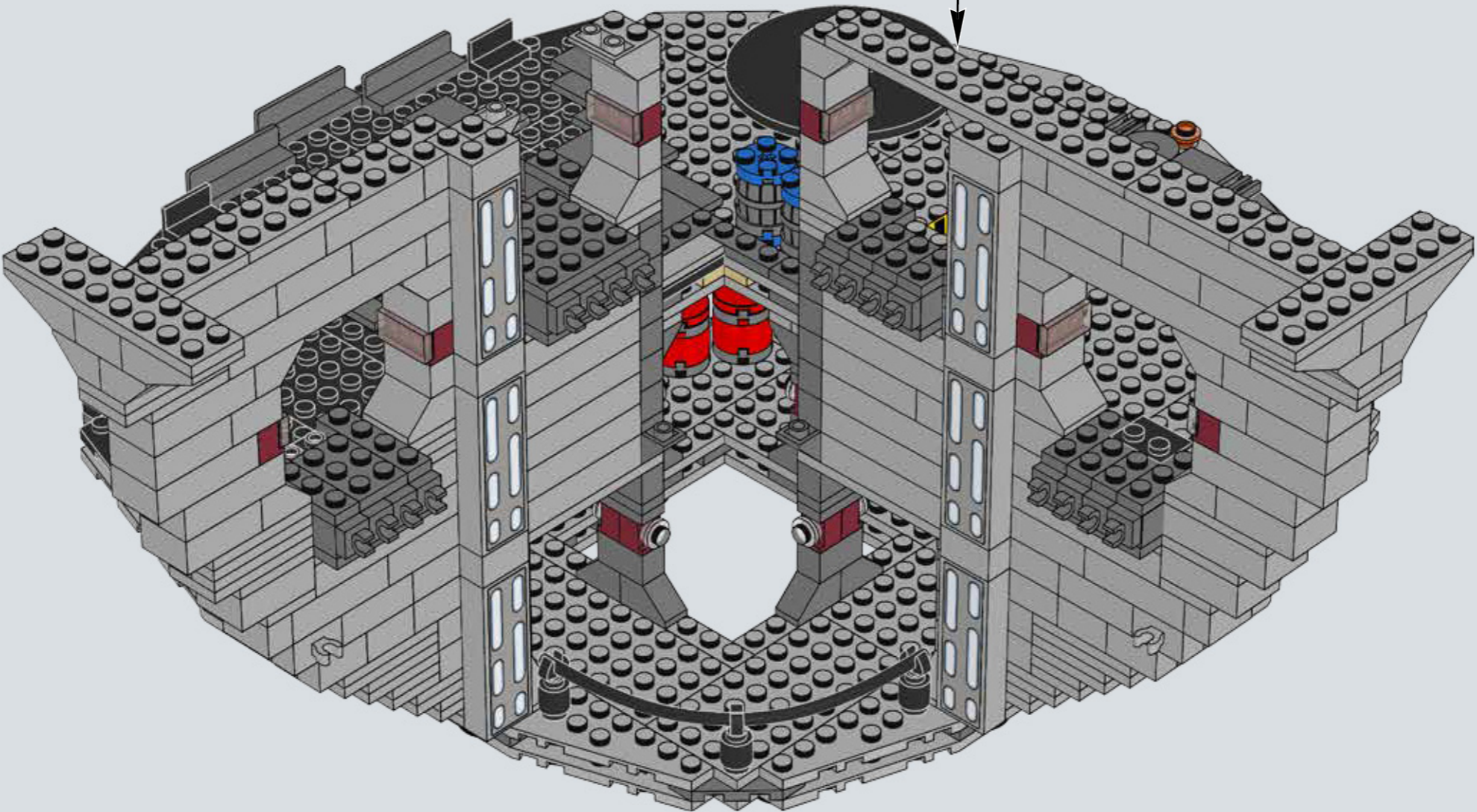
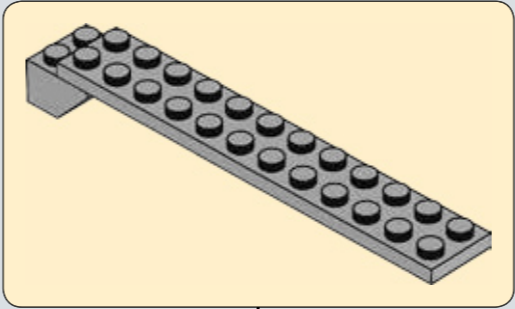

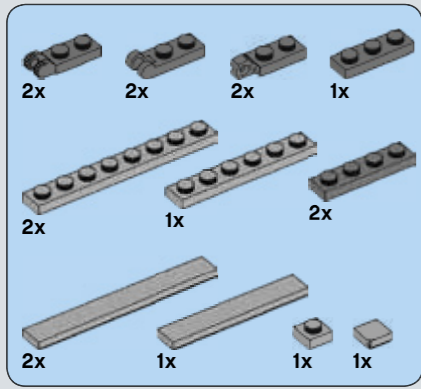

76

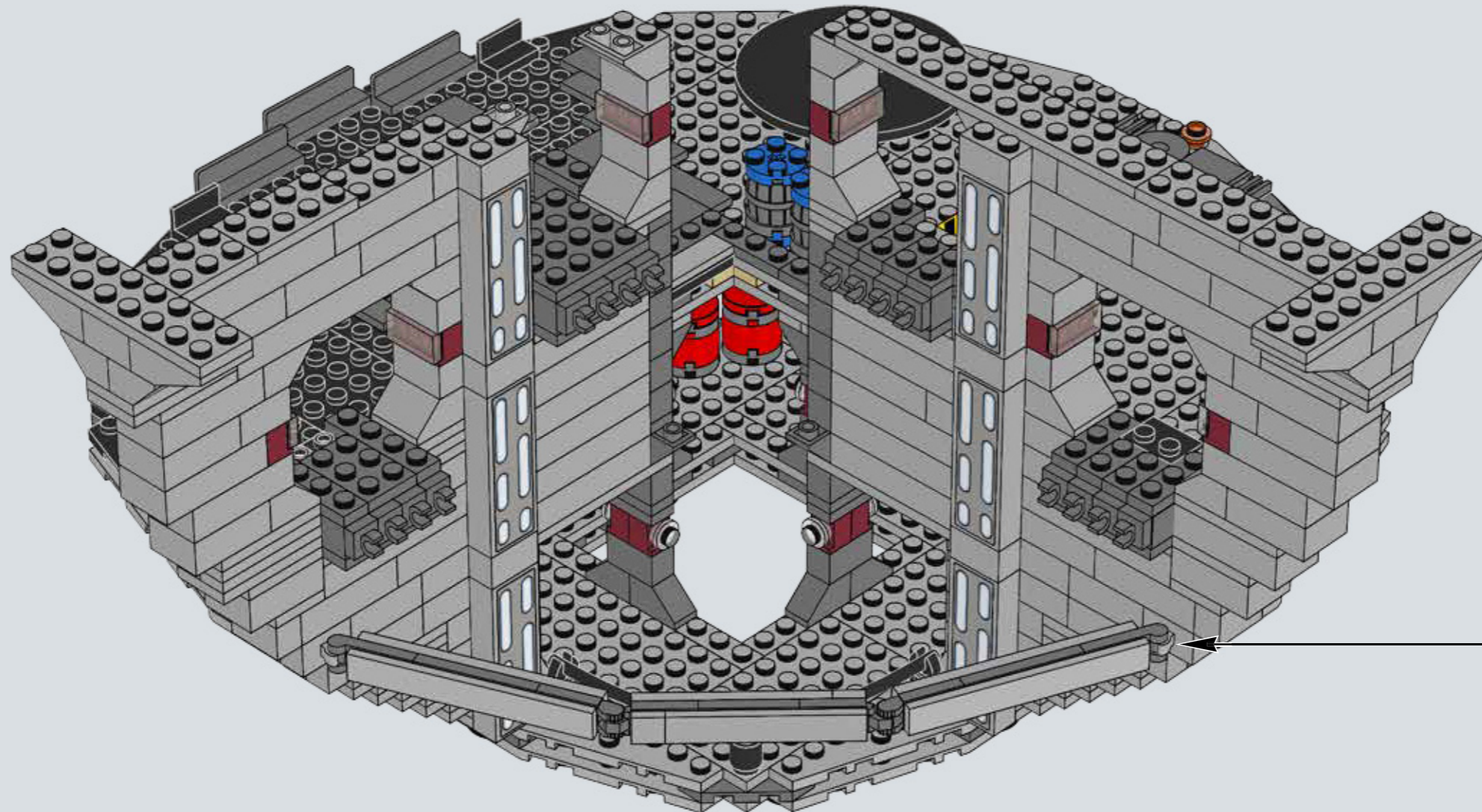
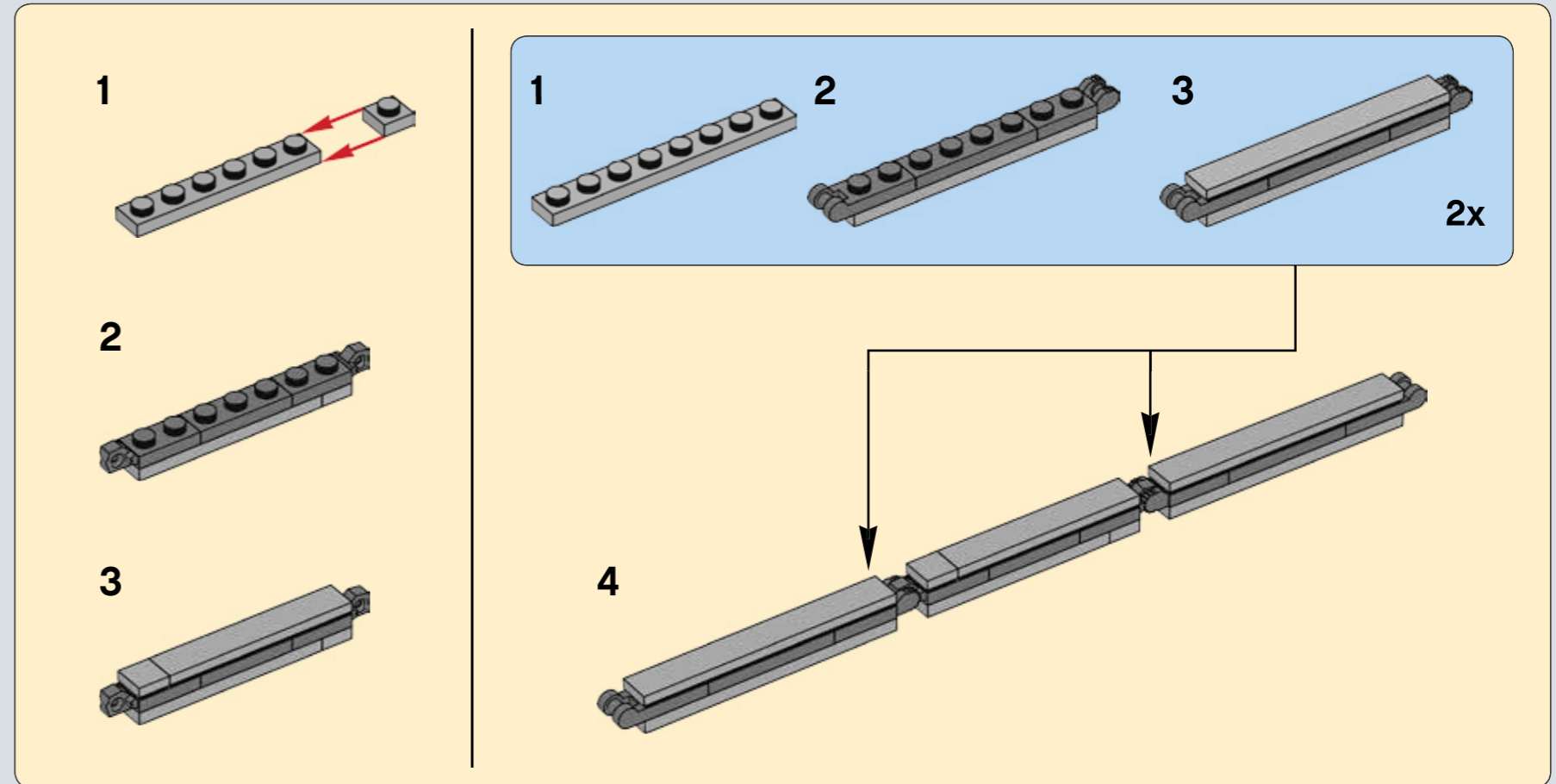

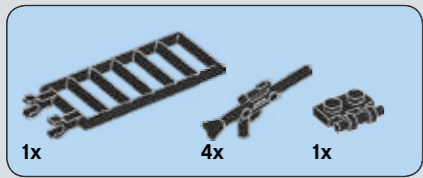

77

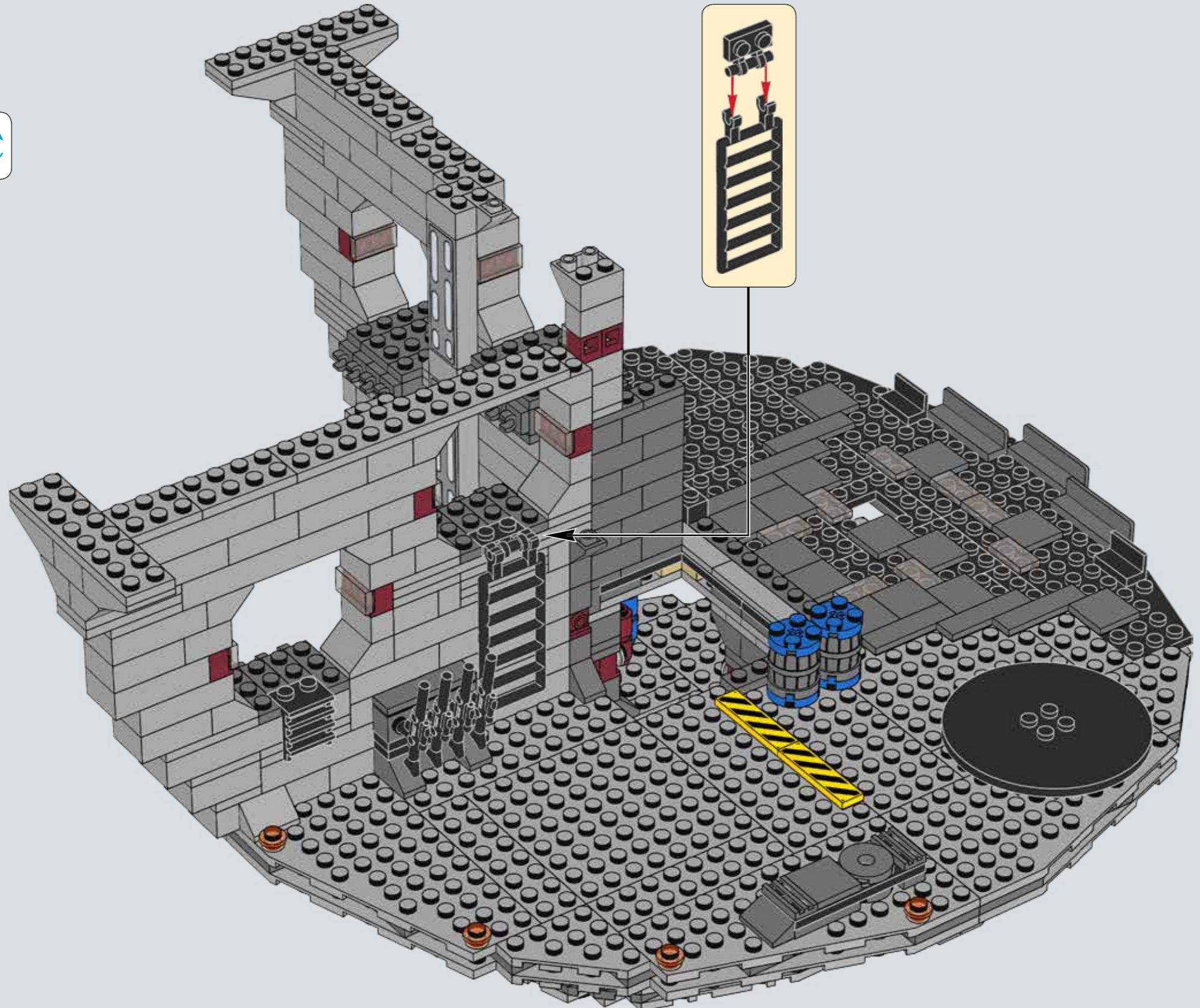



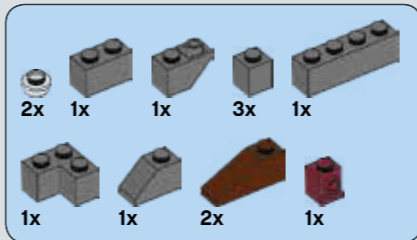
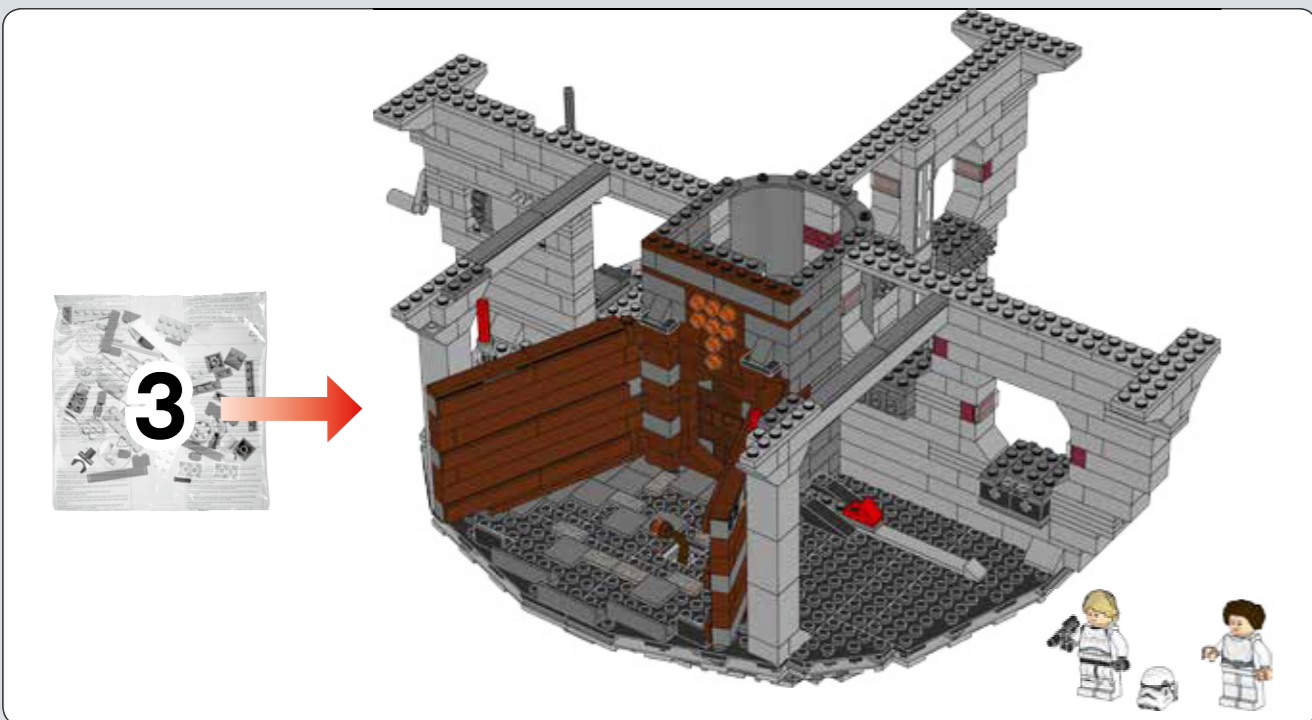

78

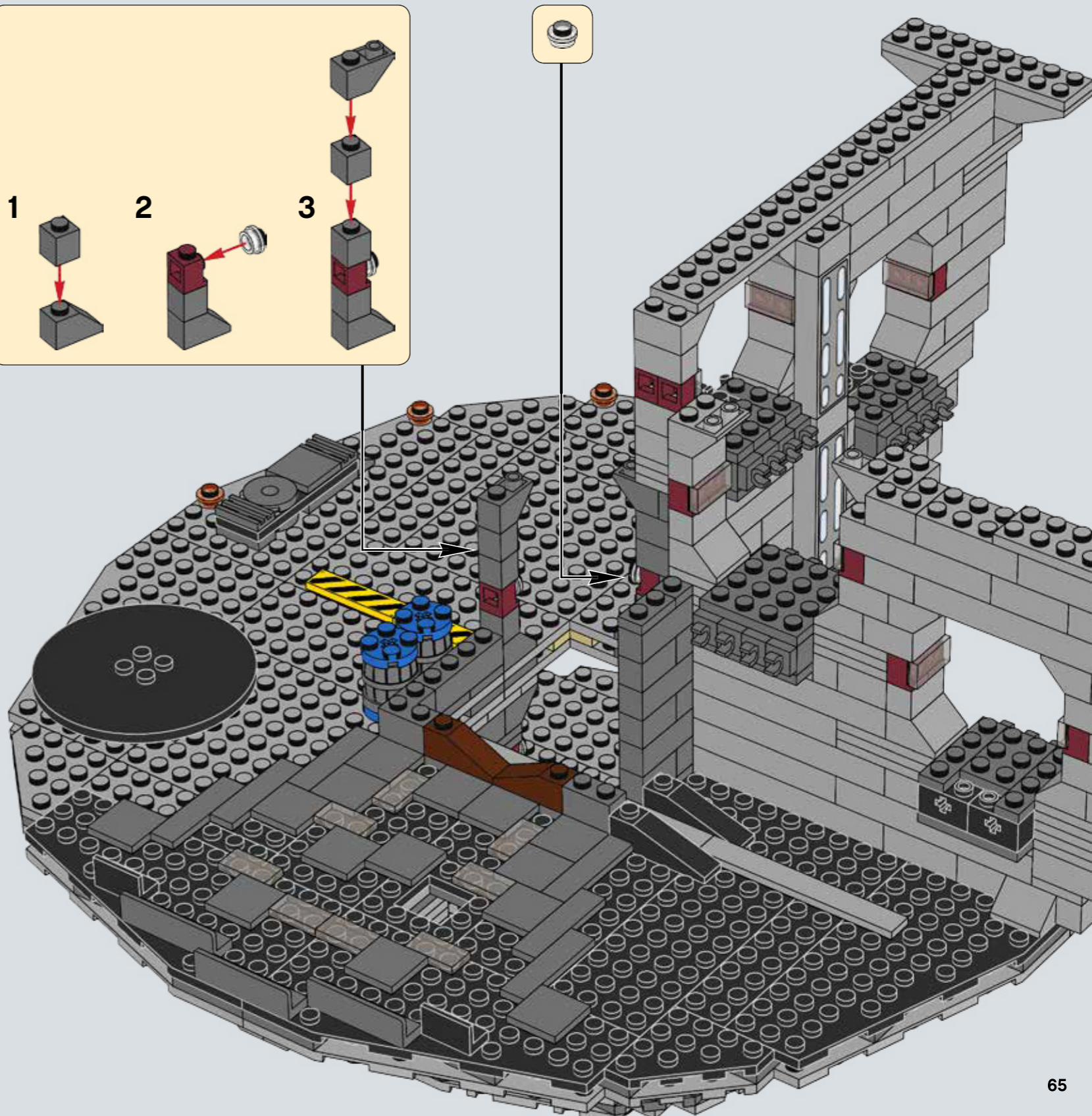
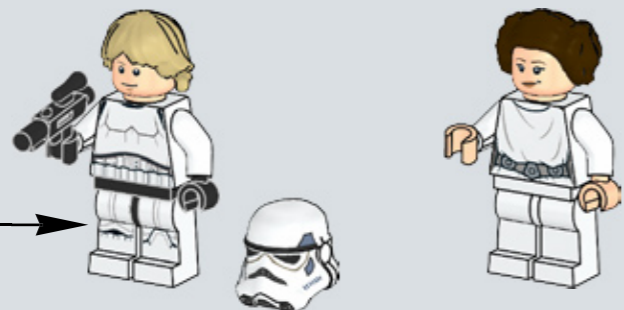
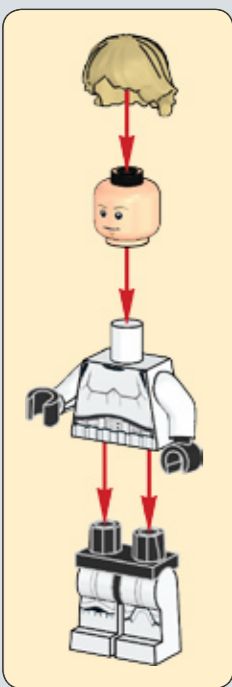
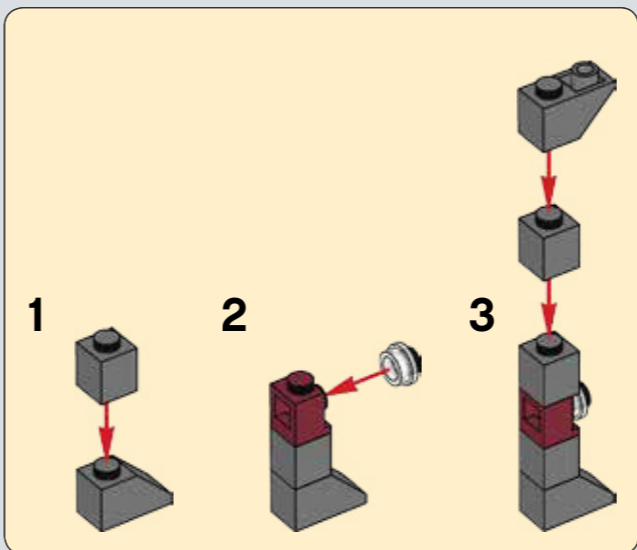
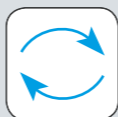

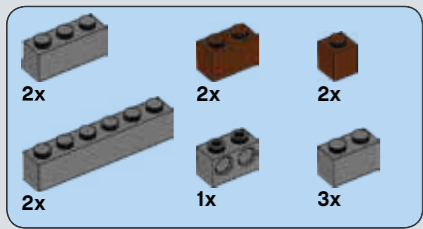

79

- 1
- 2
- 3
- 4

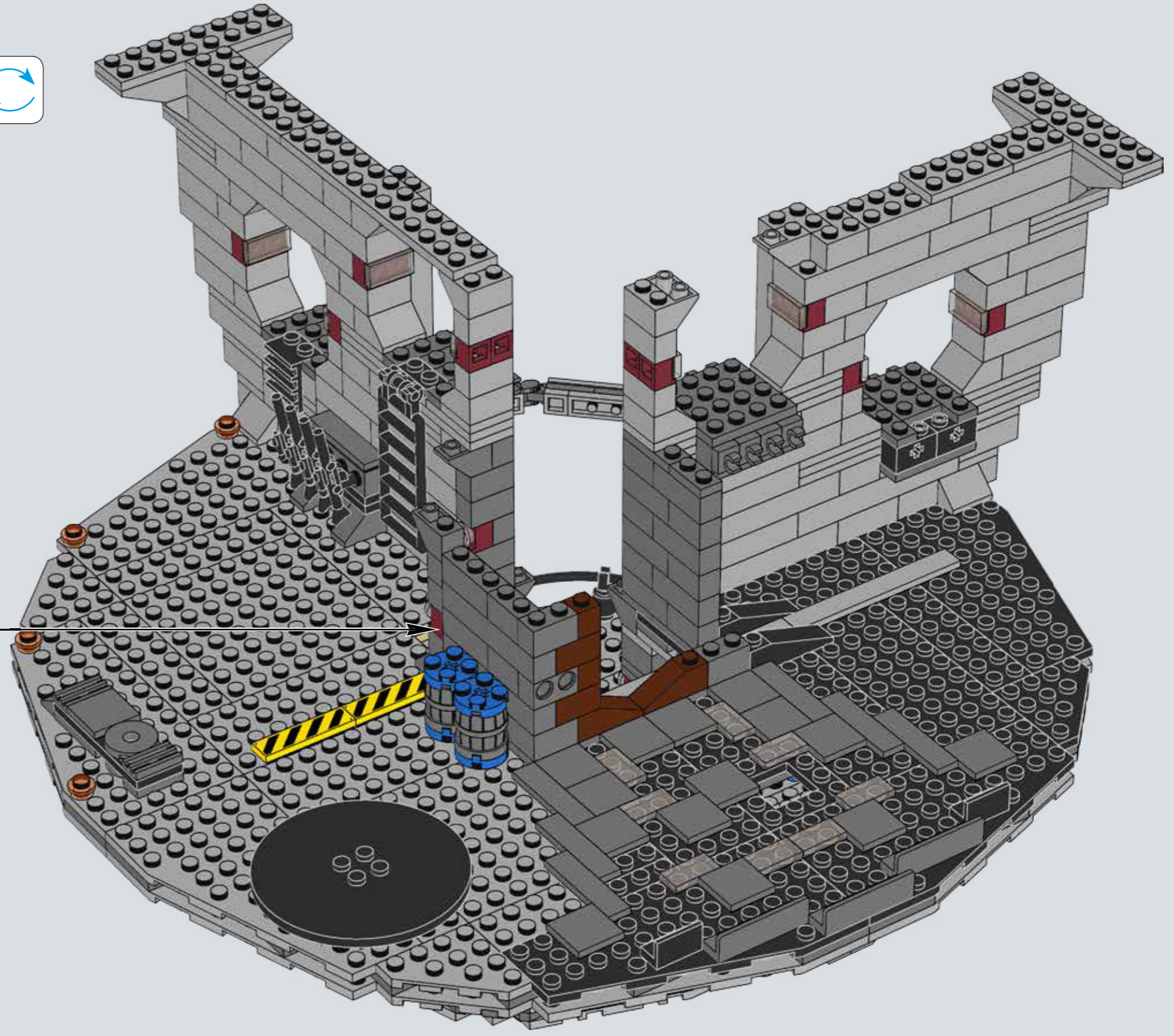

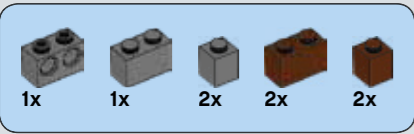

80

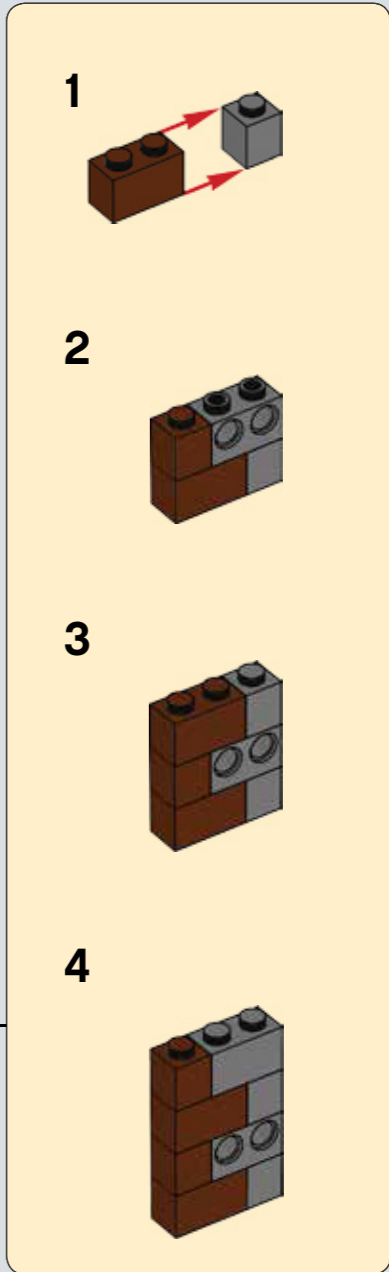
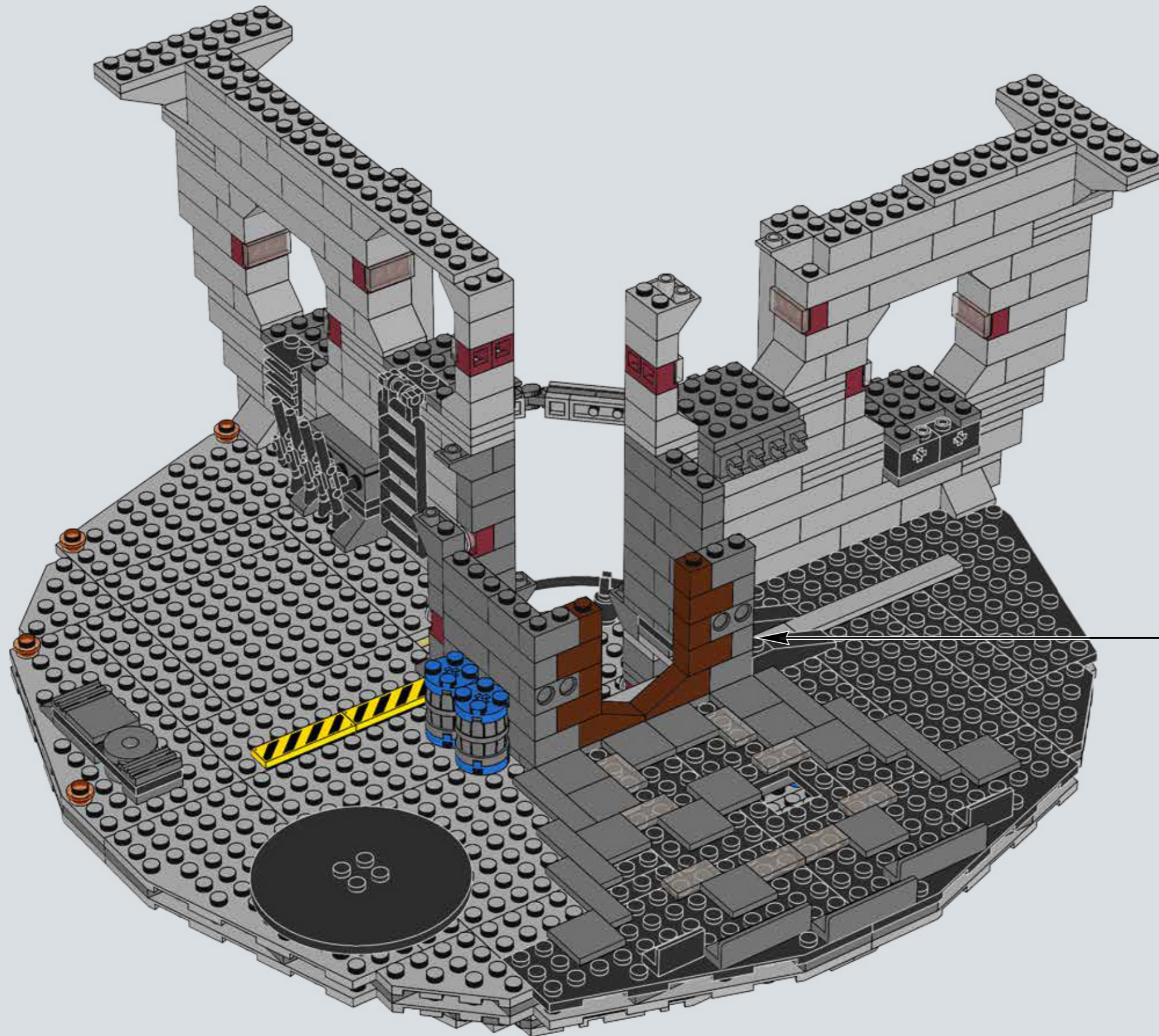

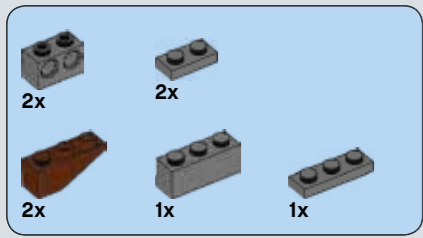

# 81

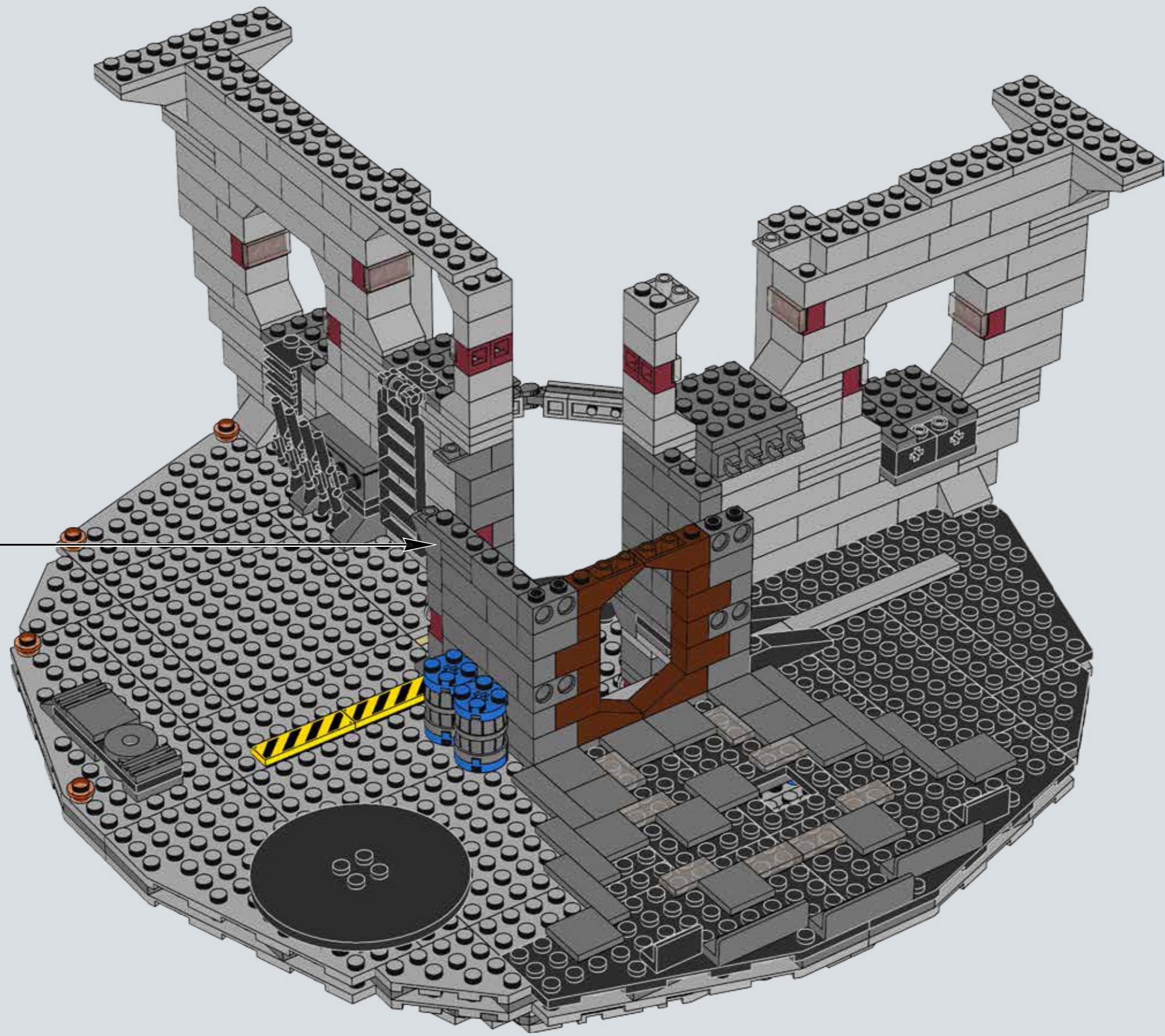
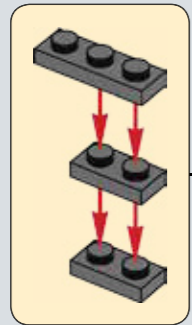

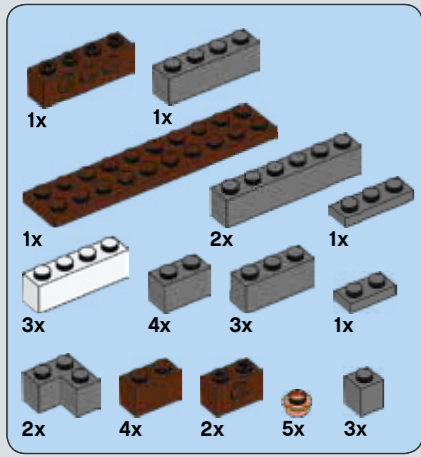

82

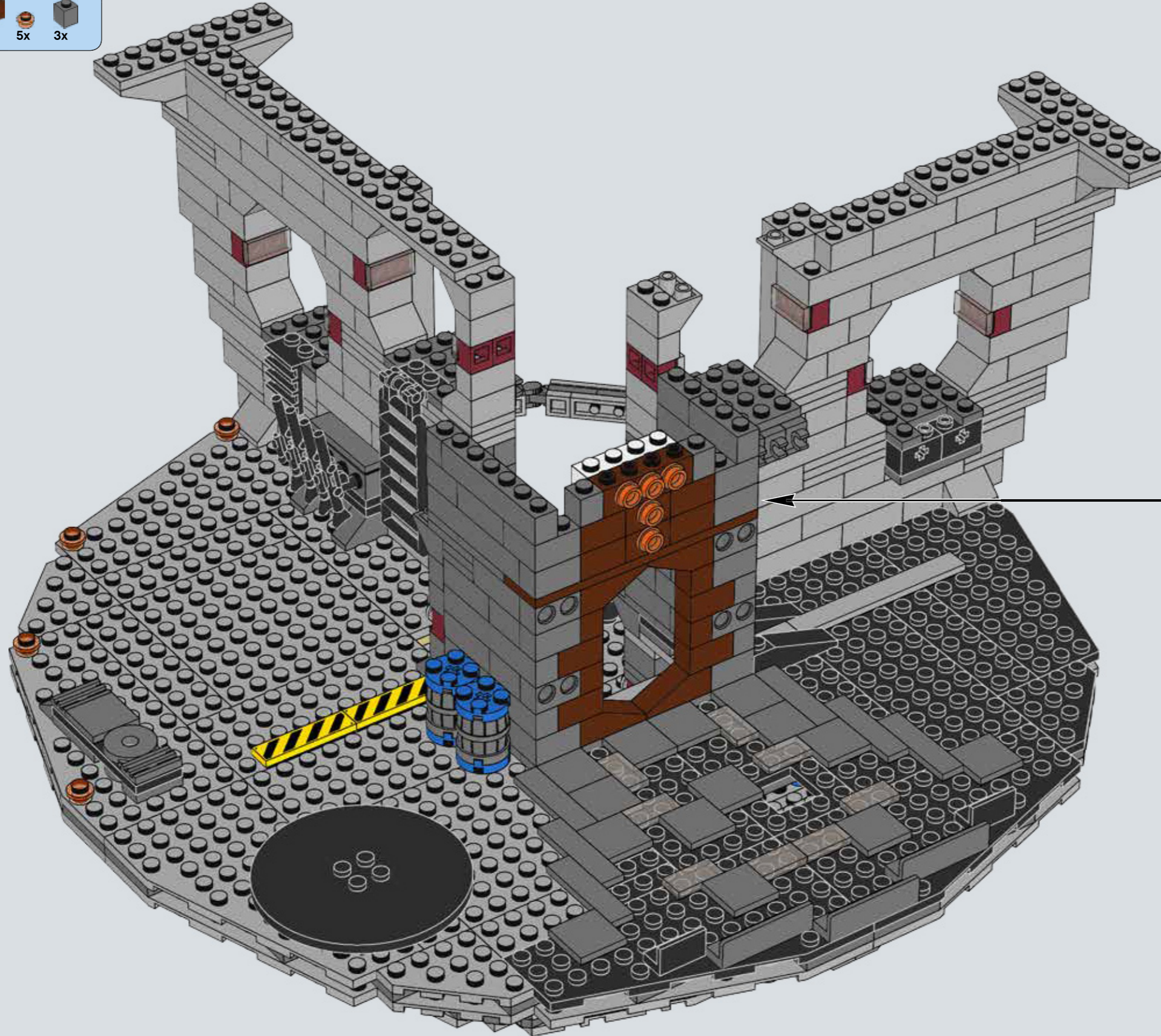

1

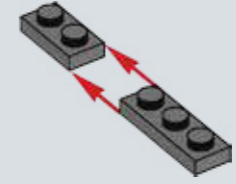

2

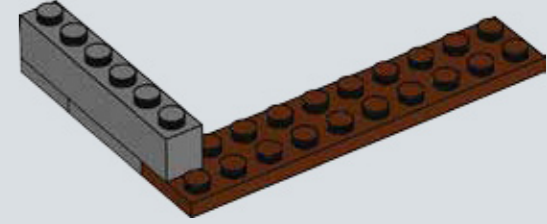

3

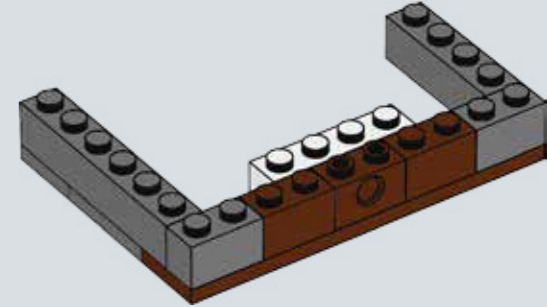

4

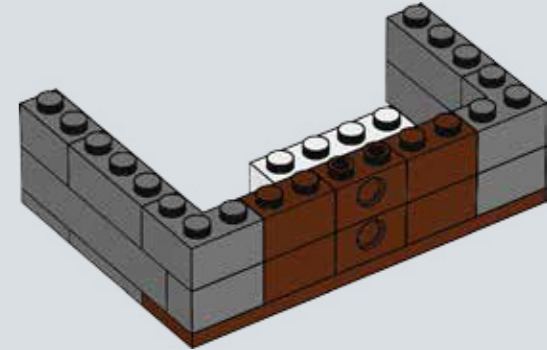

5

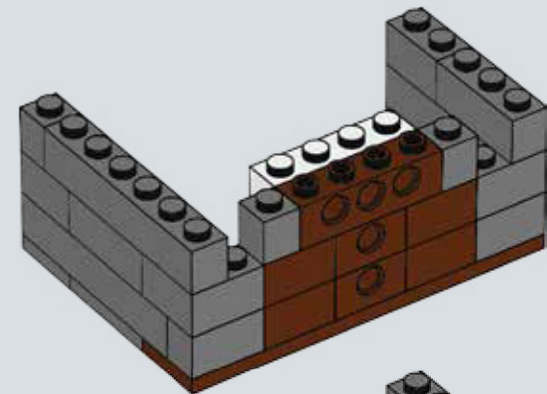

6

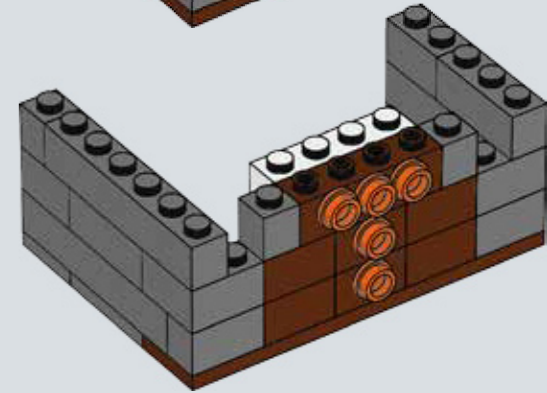

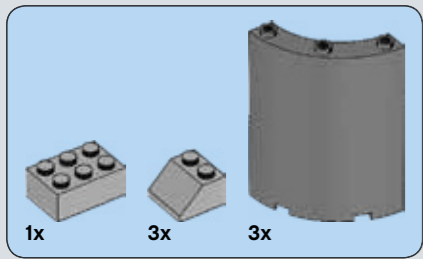

# 83

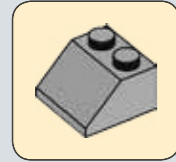
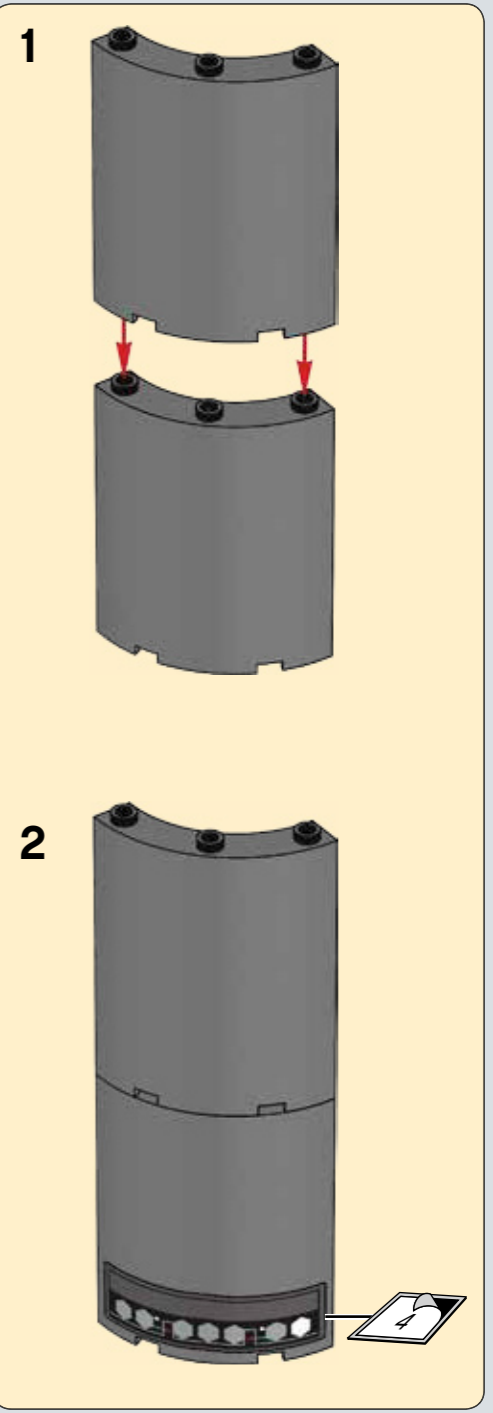
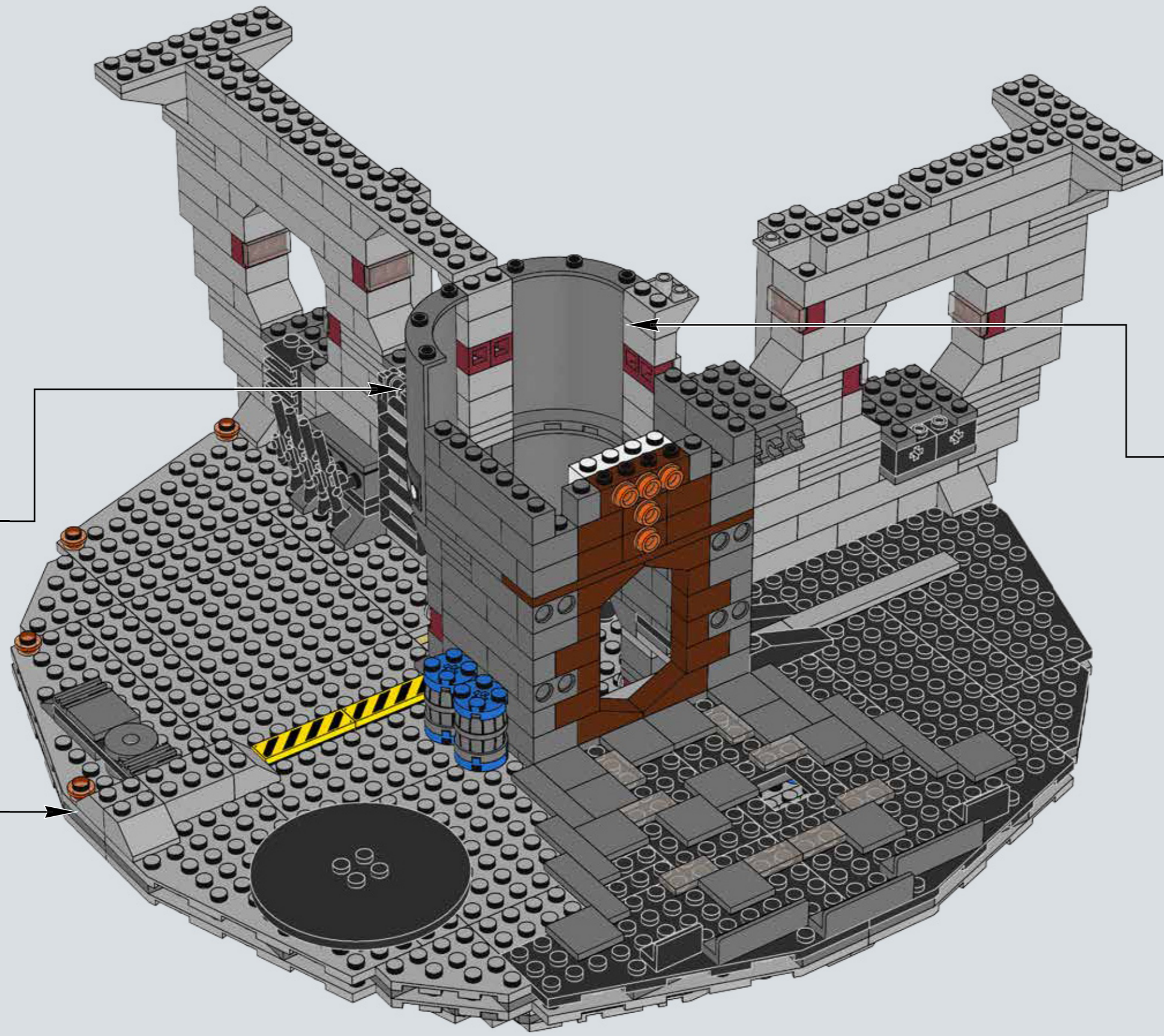
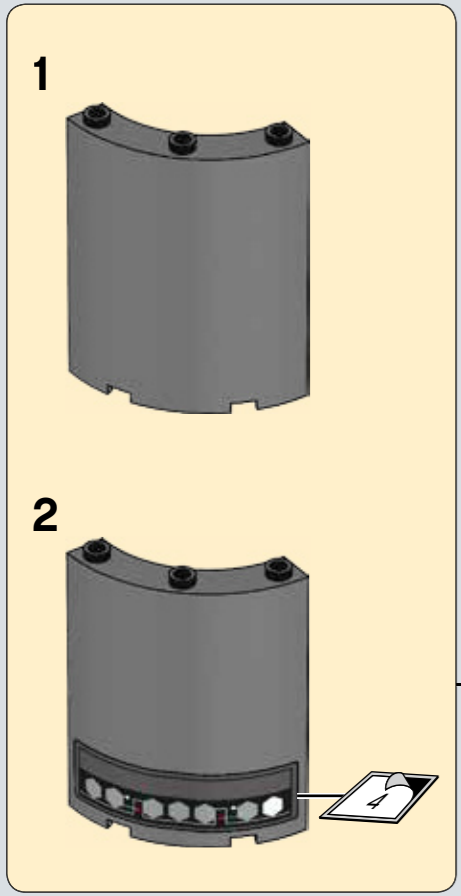

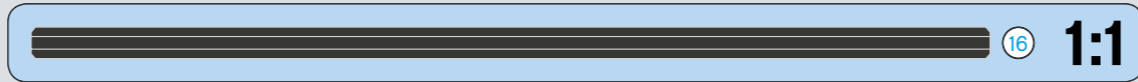
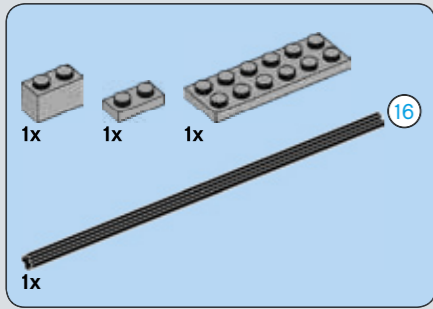

84

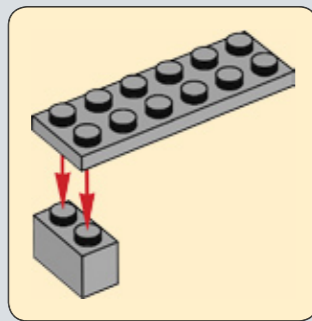
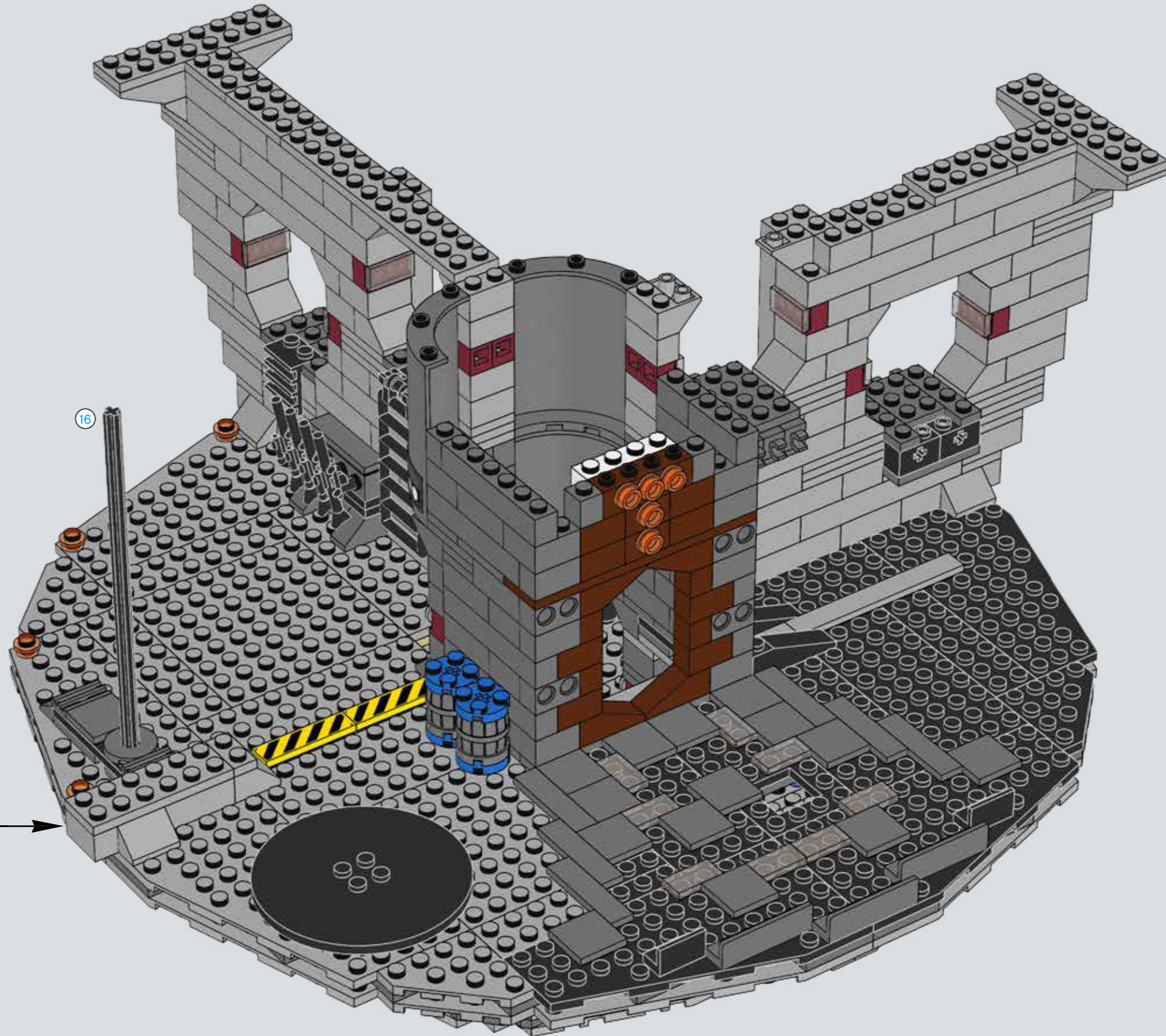

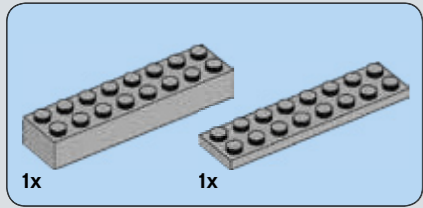
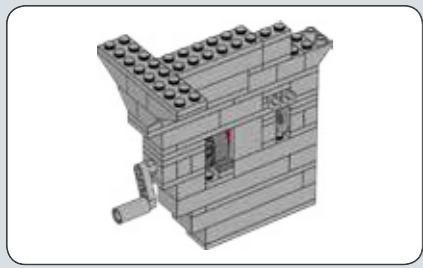

85

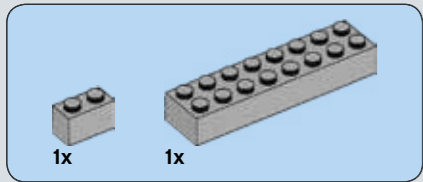
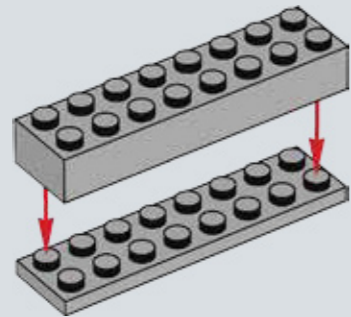

86

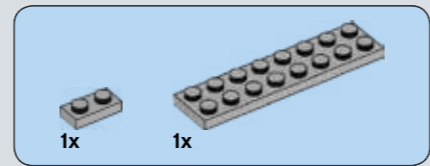
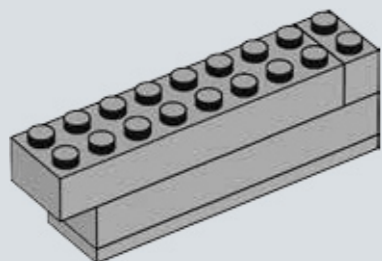

87

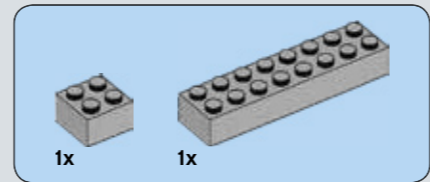
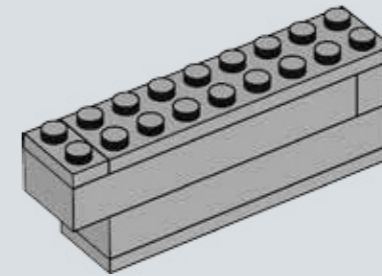

88

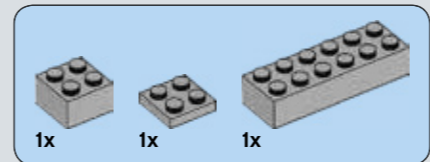
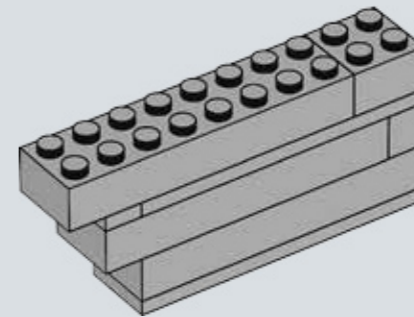

89

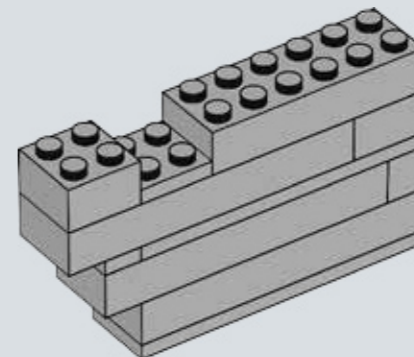



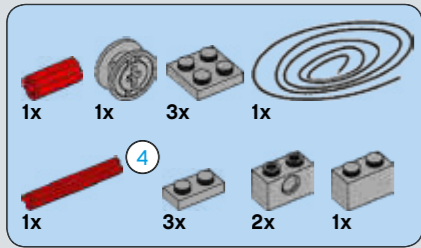

4 1:1

# 90

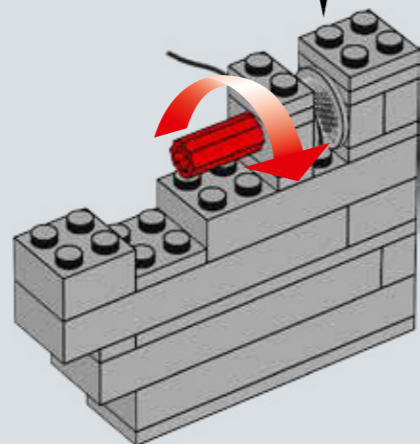
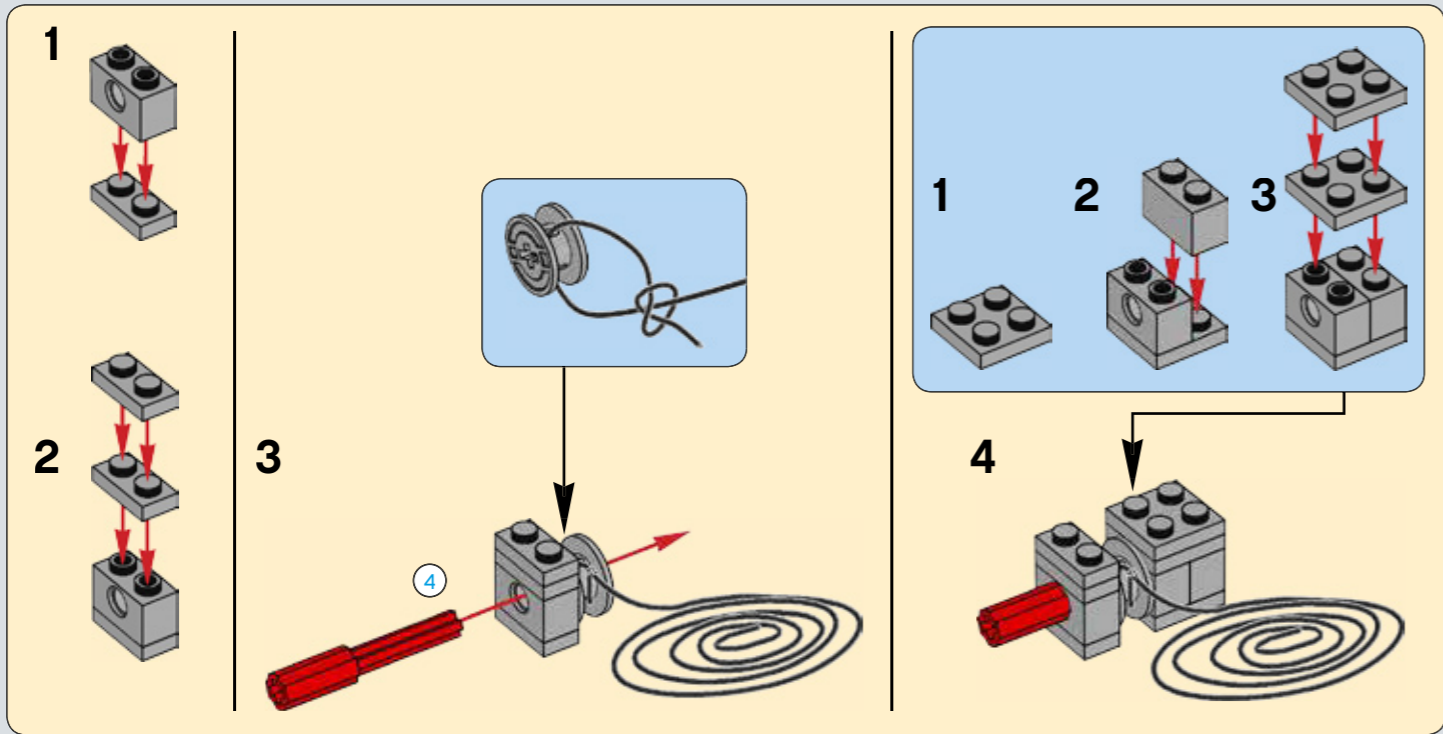

# 91

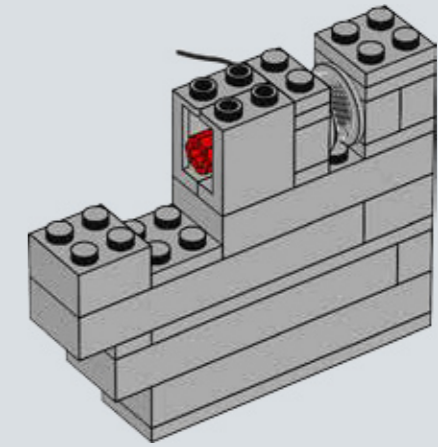

# 92

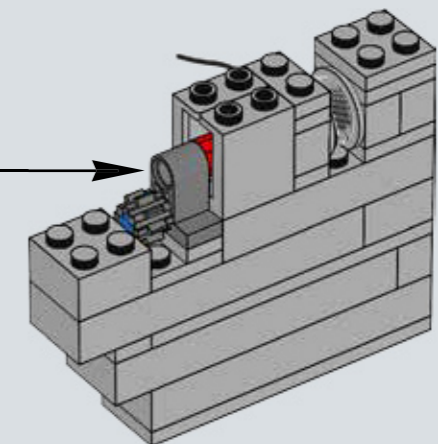
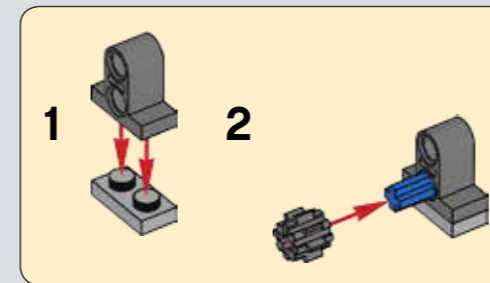

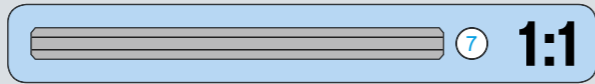
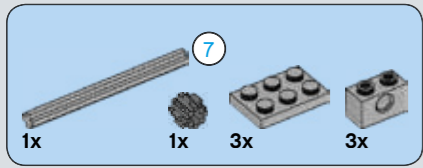

# 93

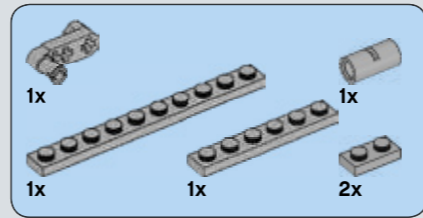
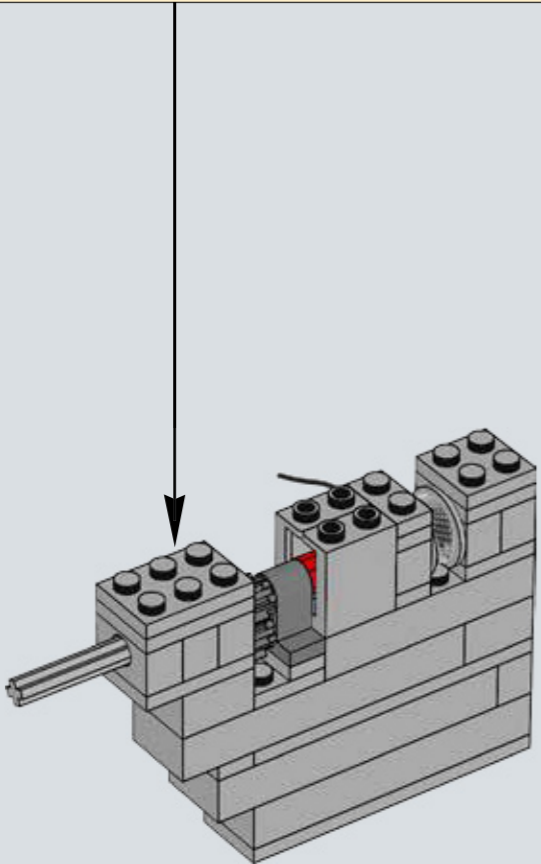
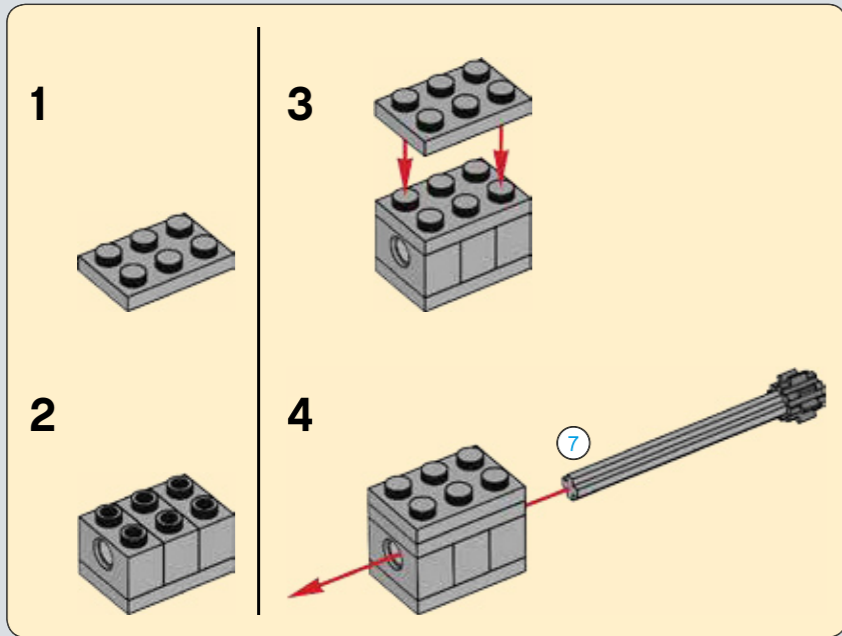

# 94

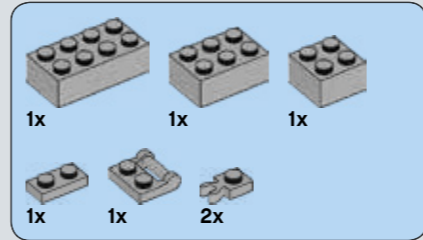
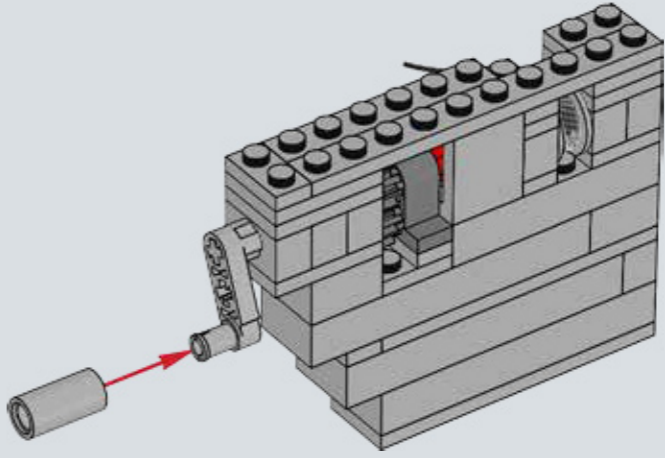

# 95

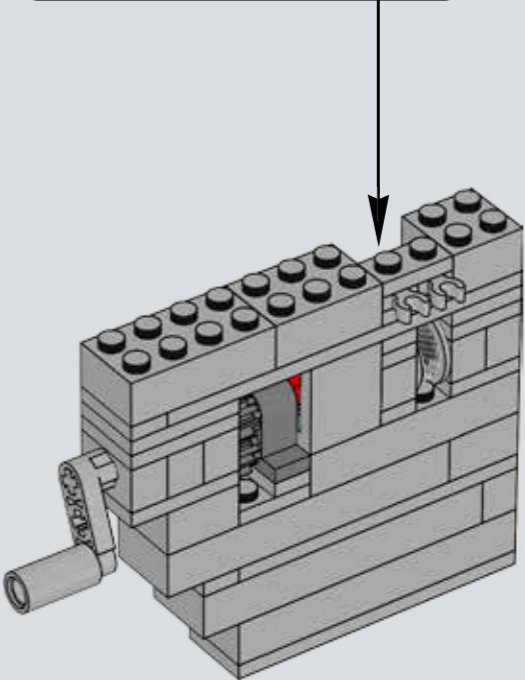
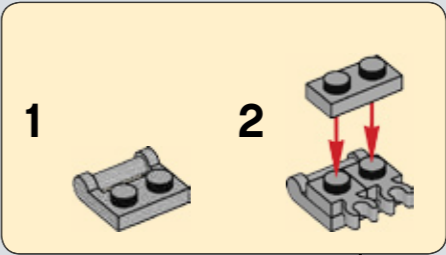

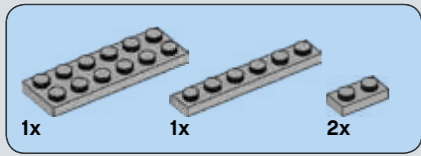

96

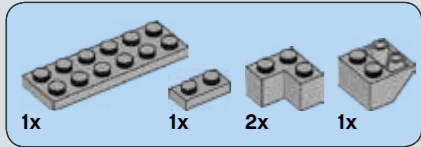
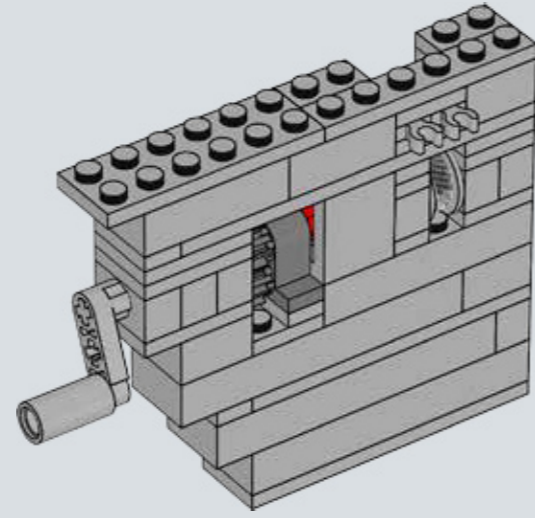

97

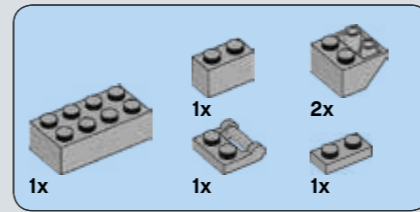
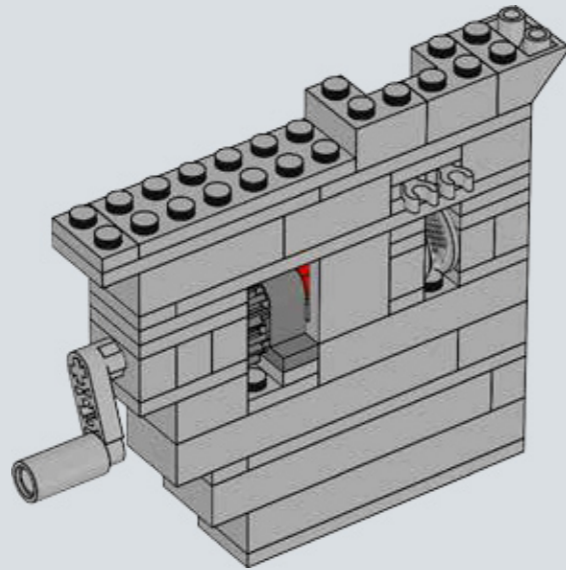

98

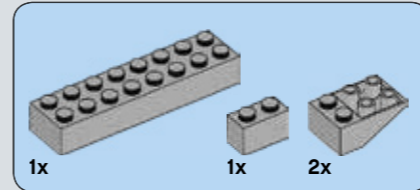
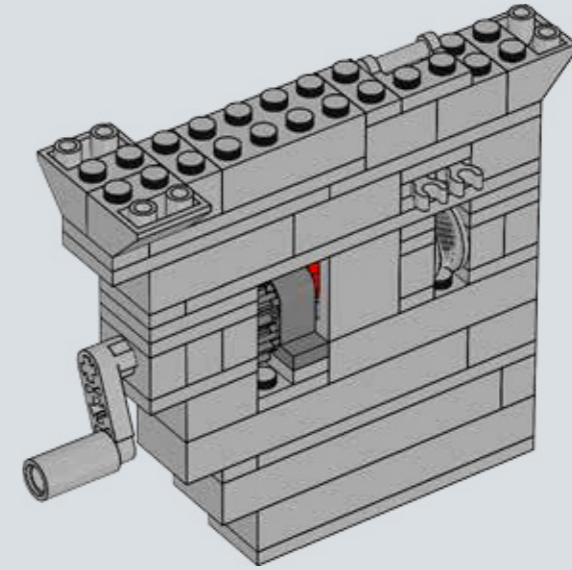

99

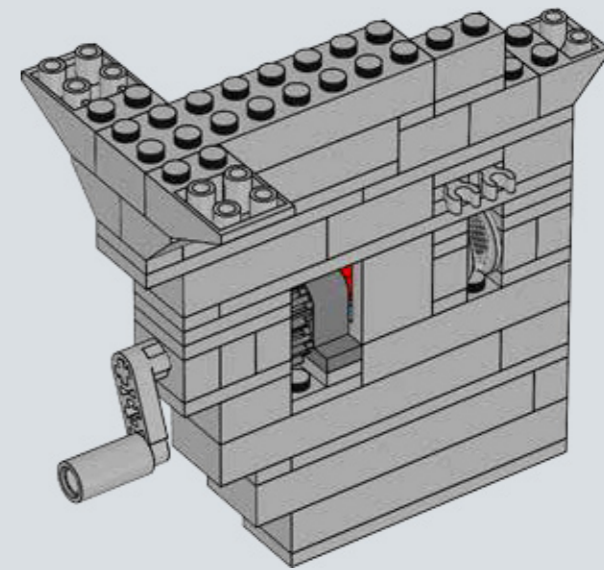

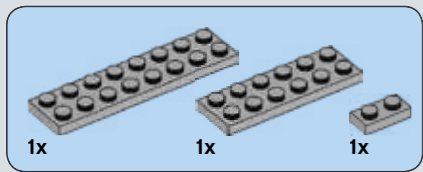

100

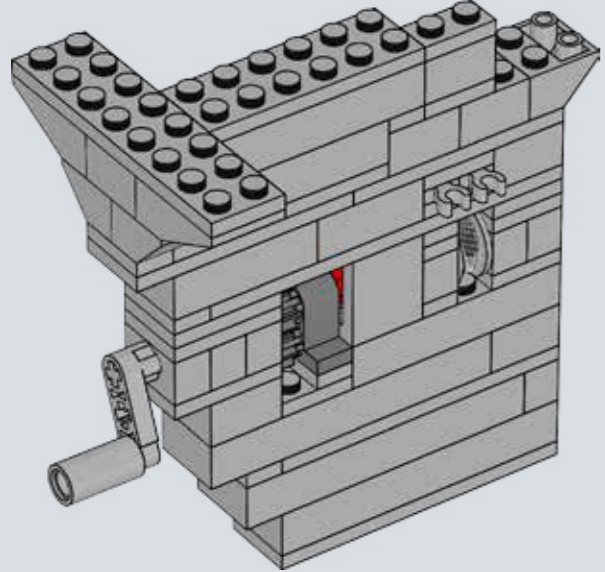

101

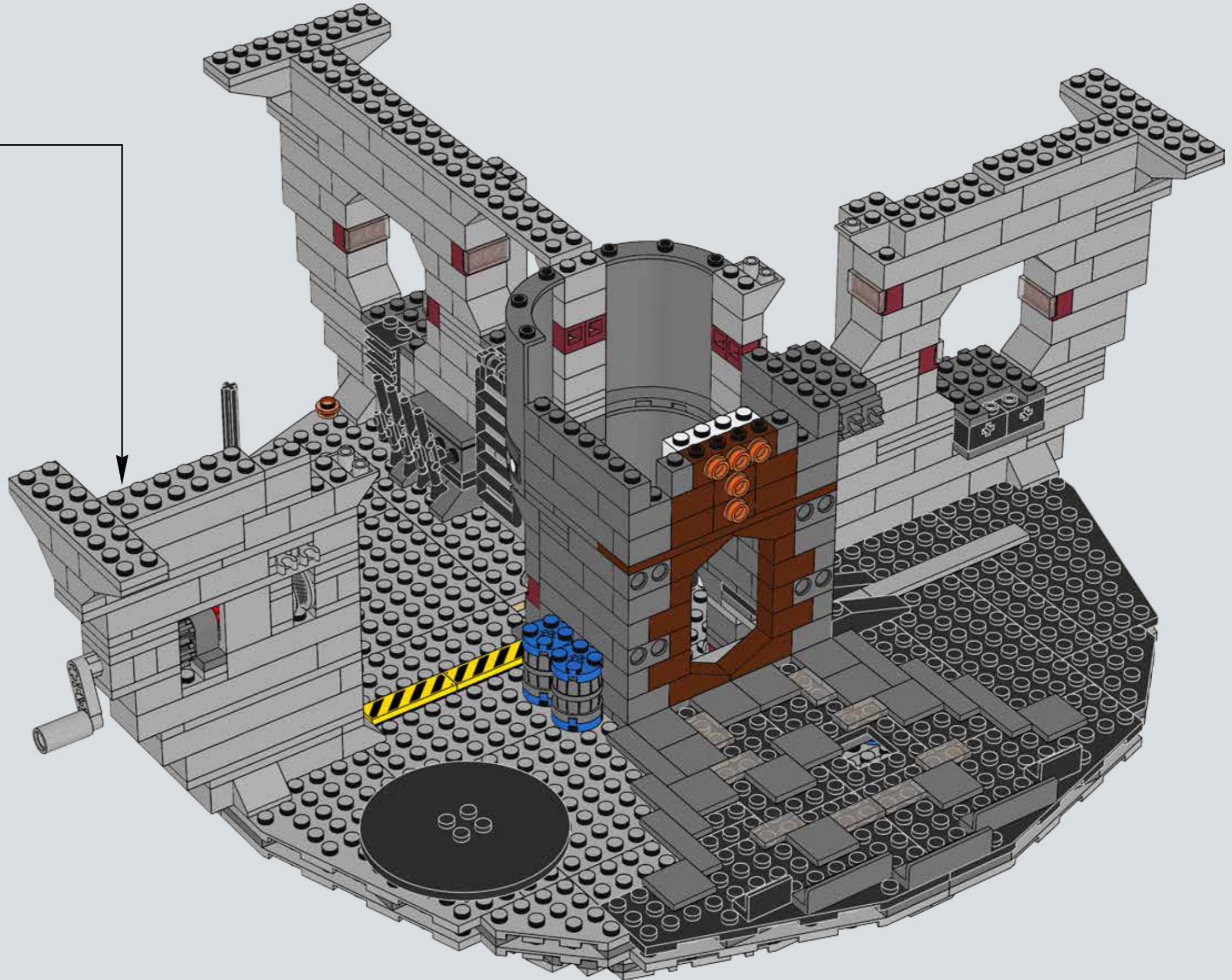

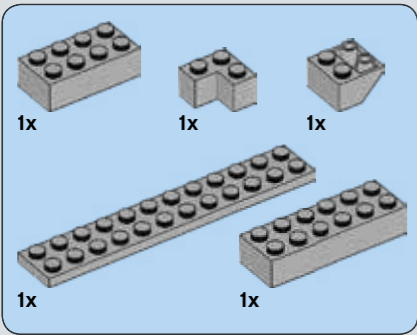

# 102

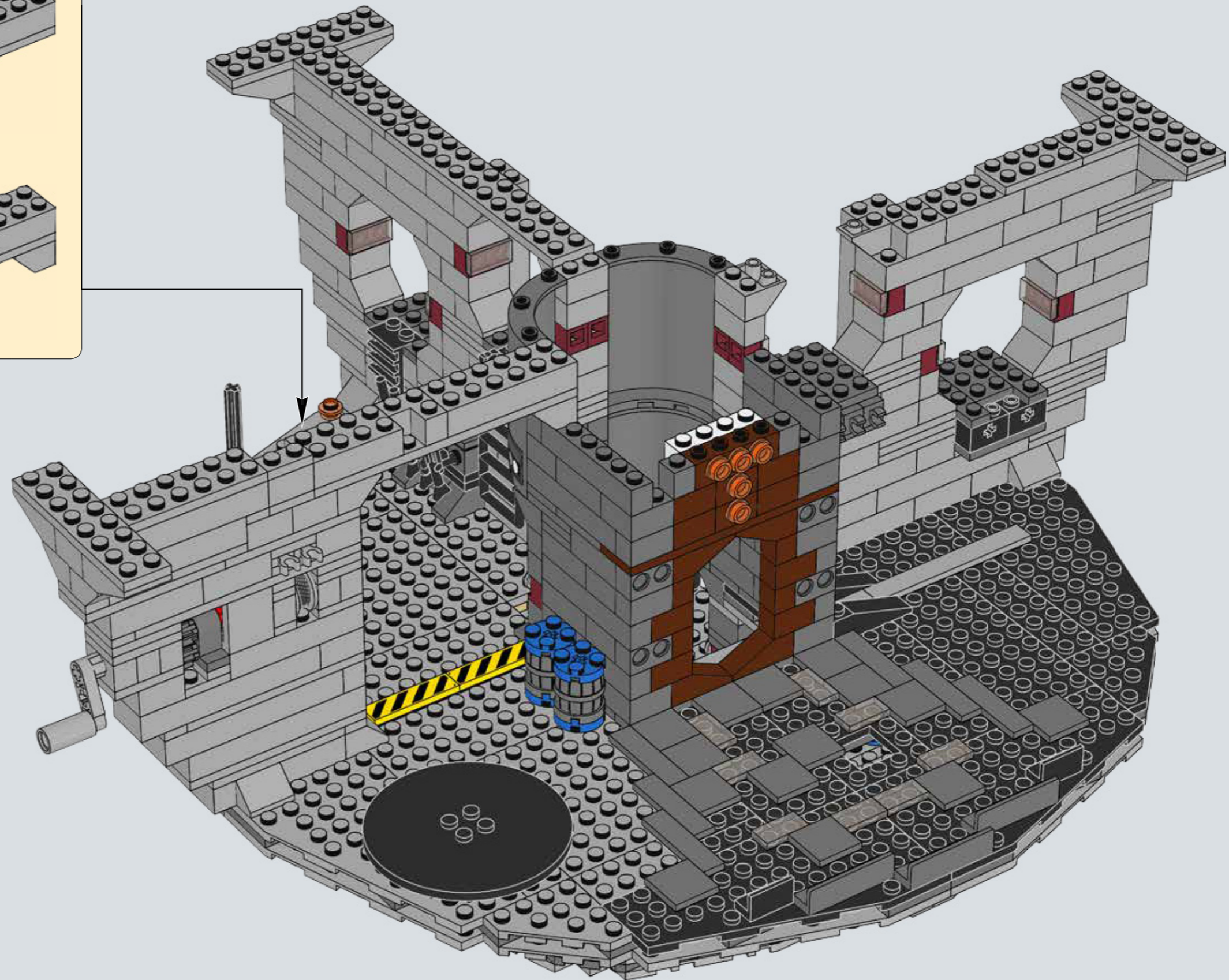
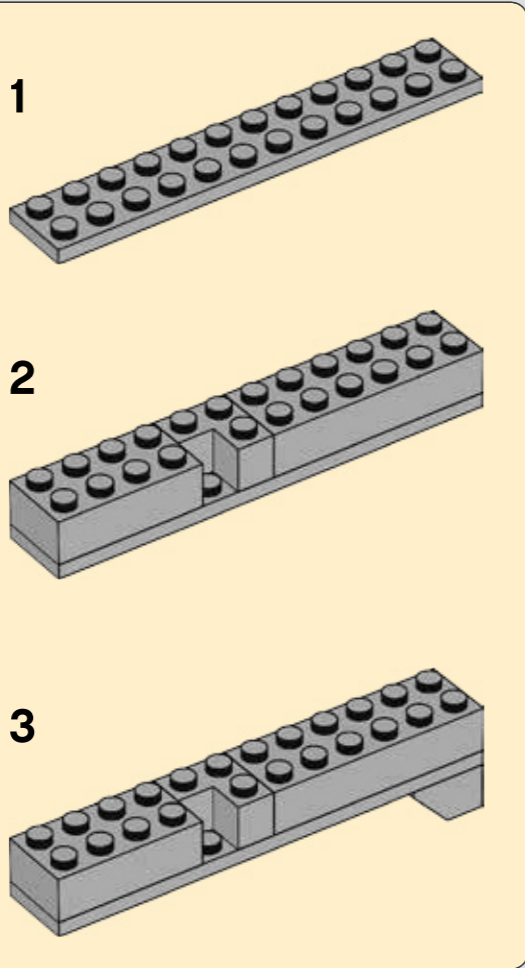

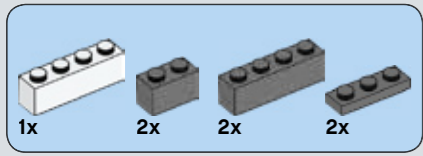

# 103

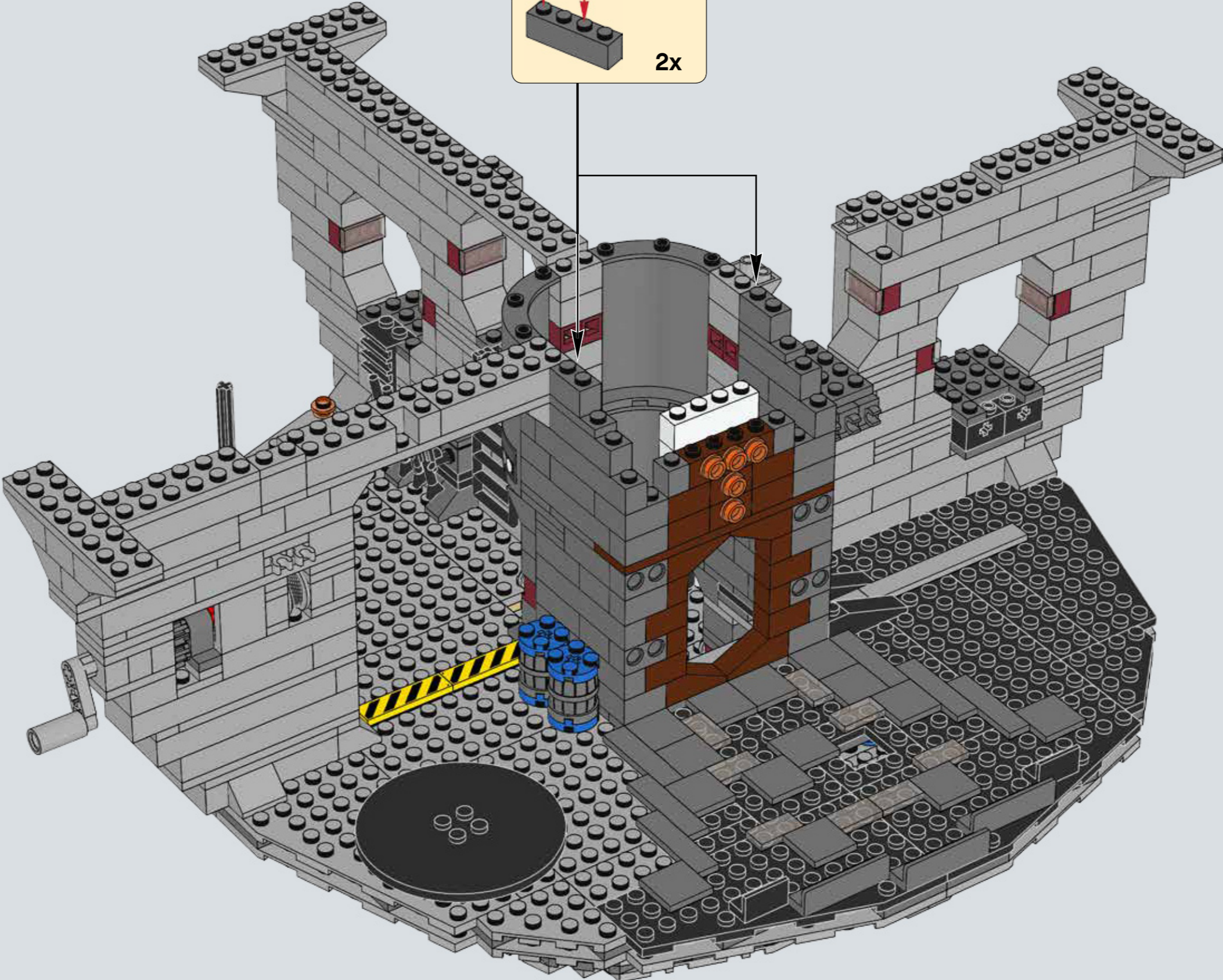
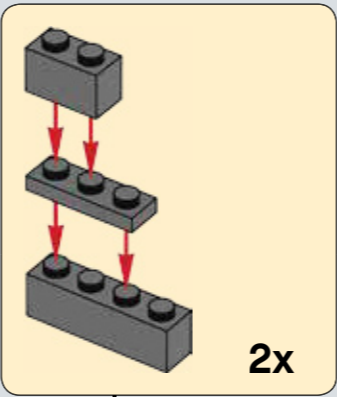

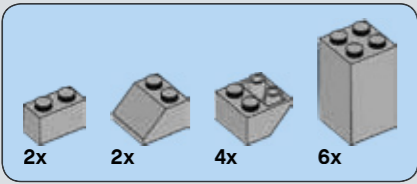

# 104

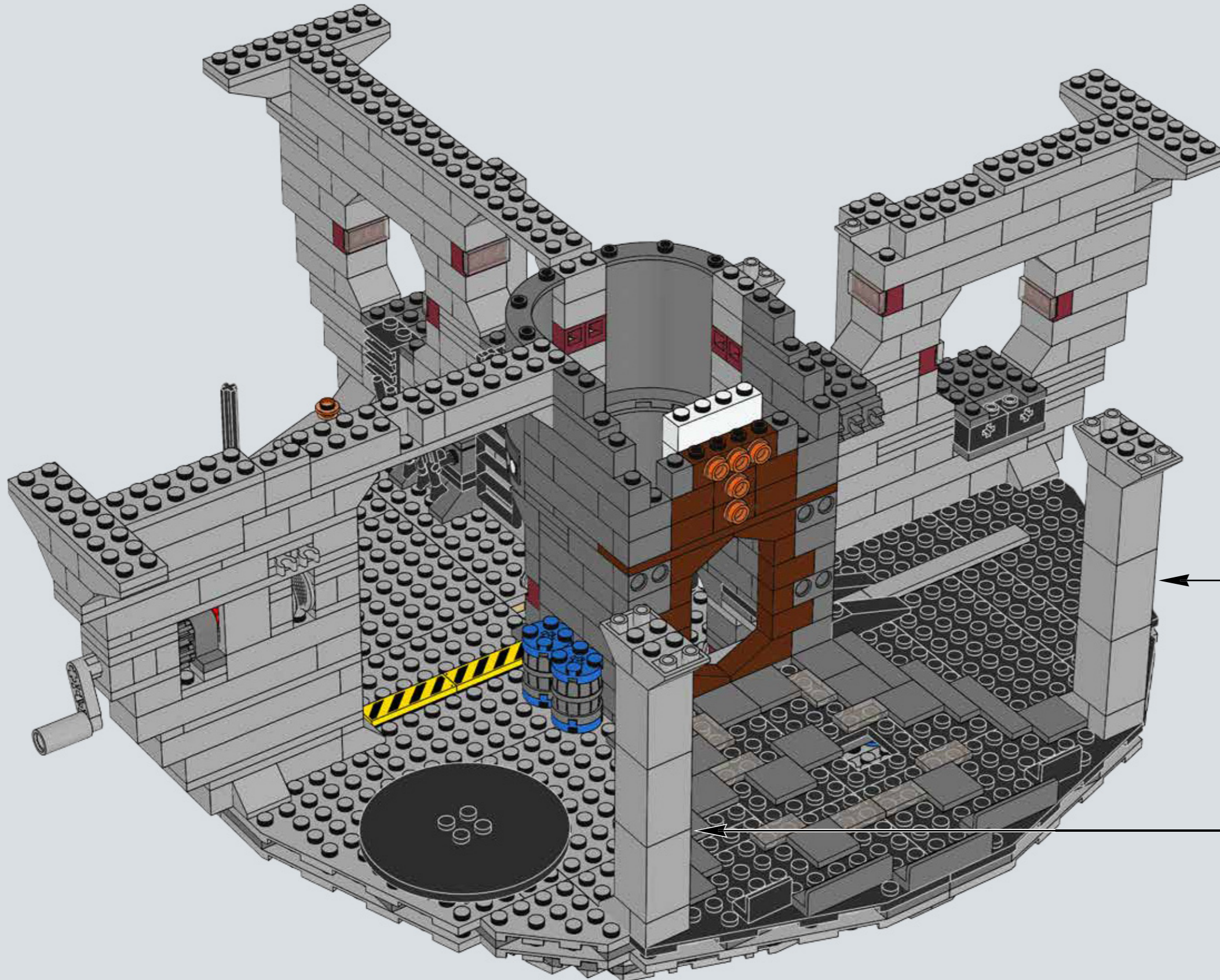

1

2

3

2x

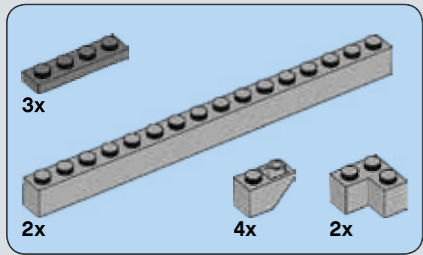

# 105

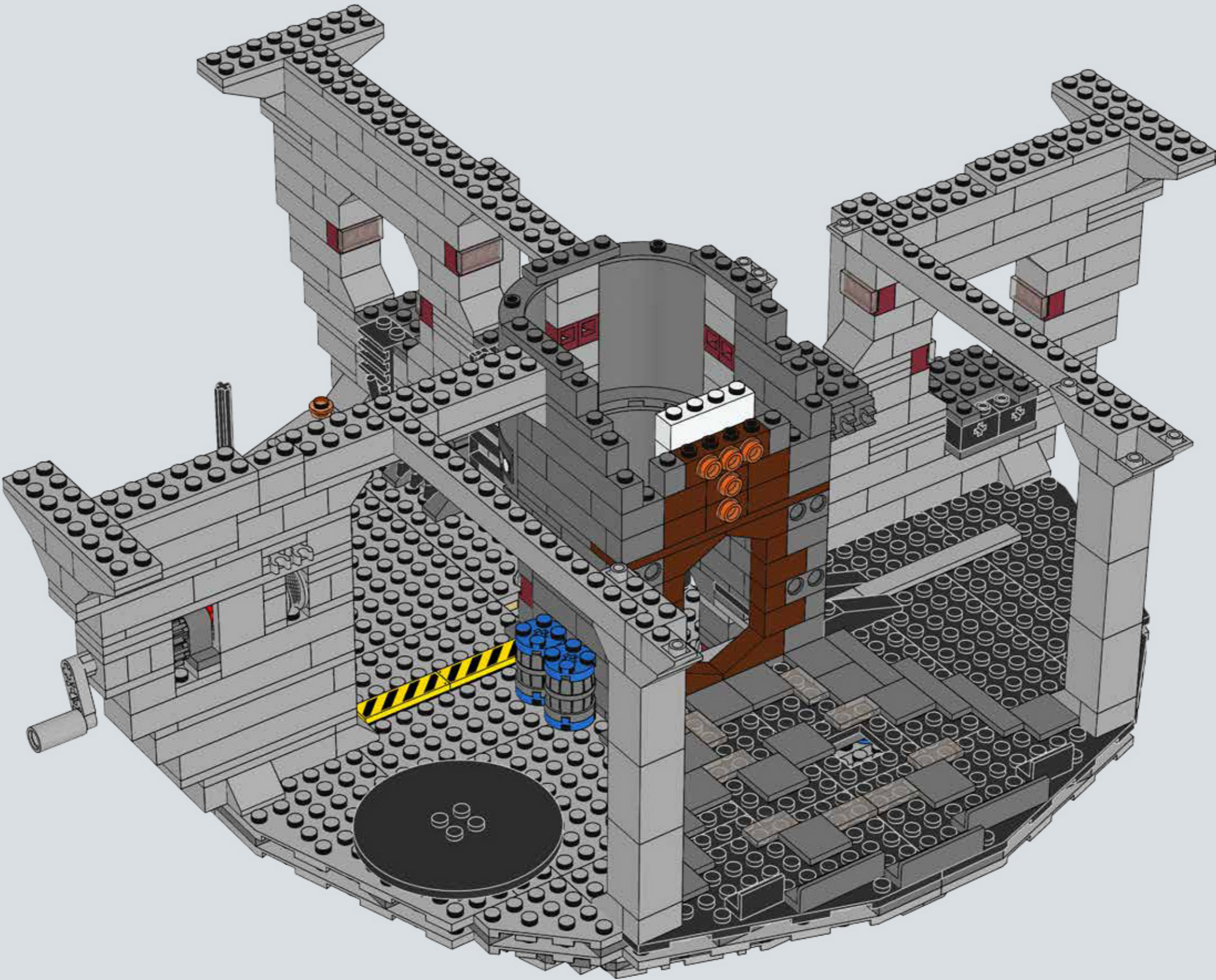



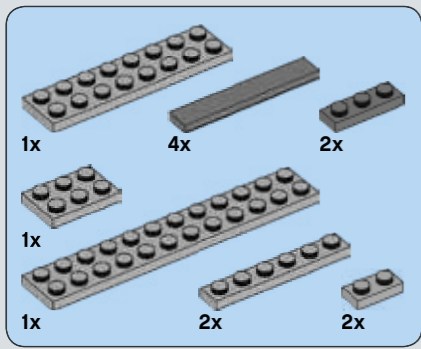

106

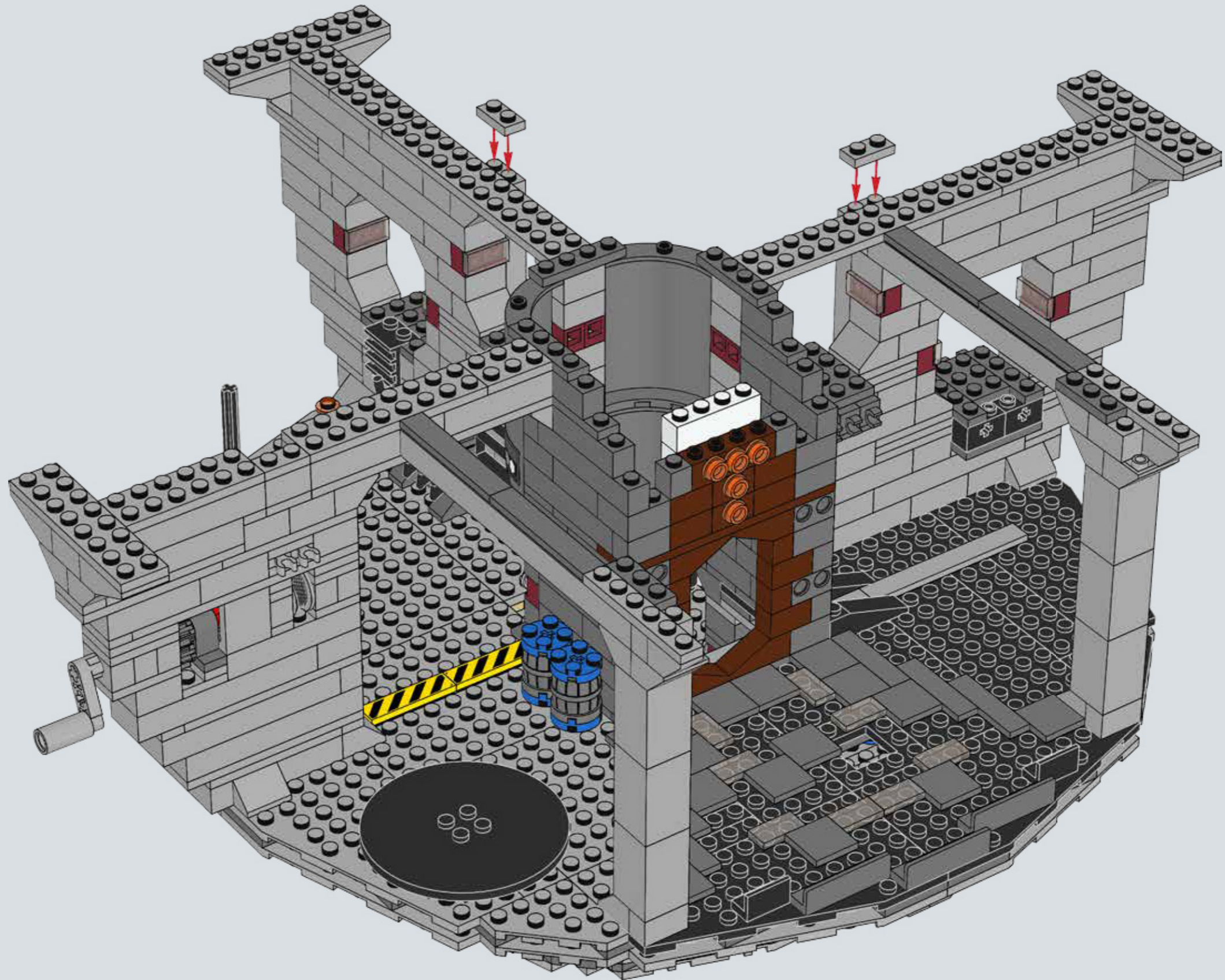

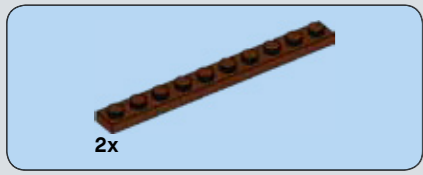
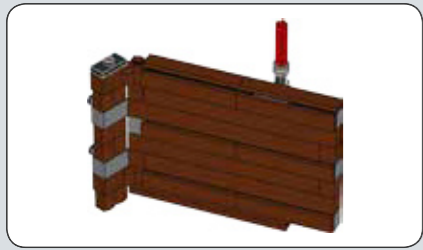

107

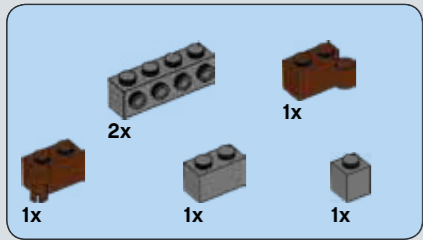
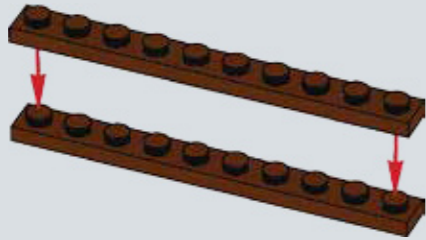

108

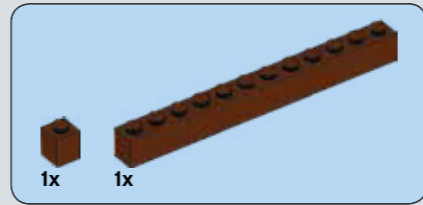
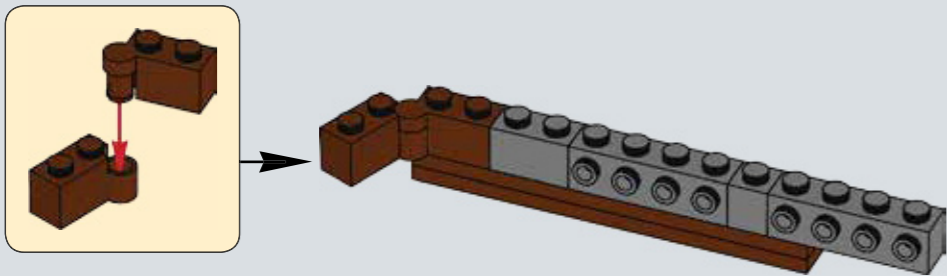

109

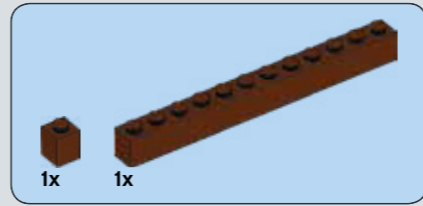
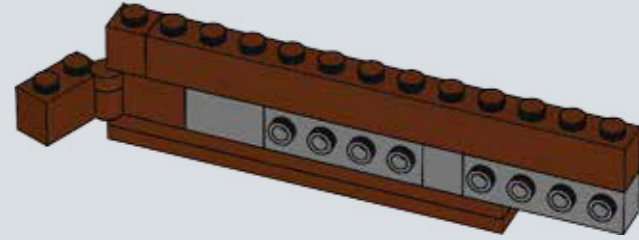

110

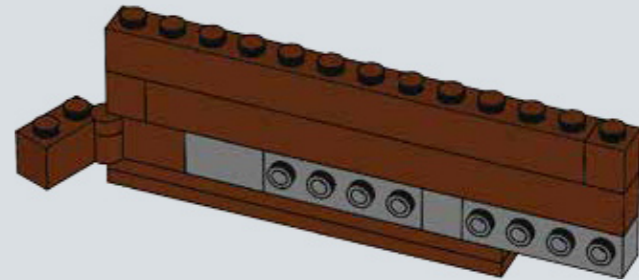

111

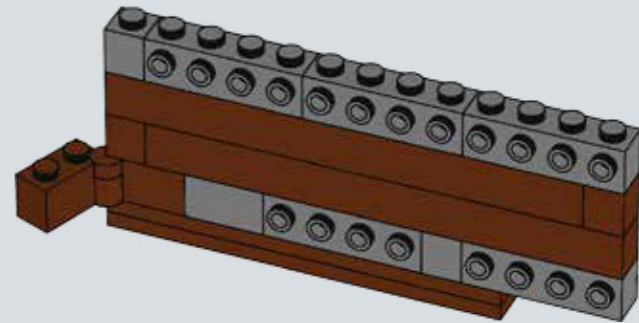

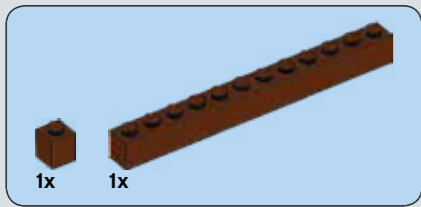

112

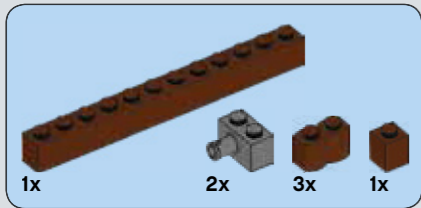
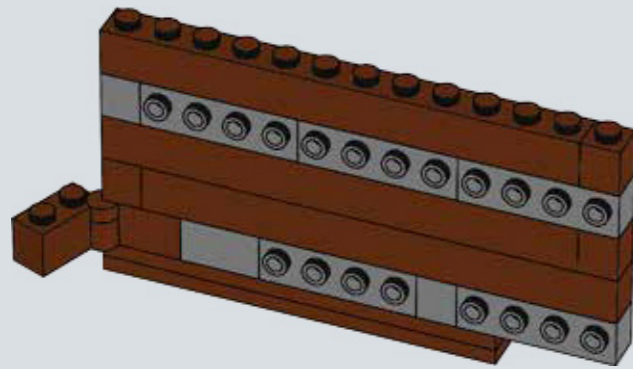

113

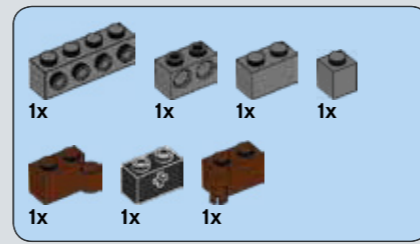
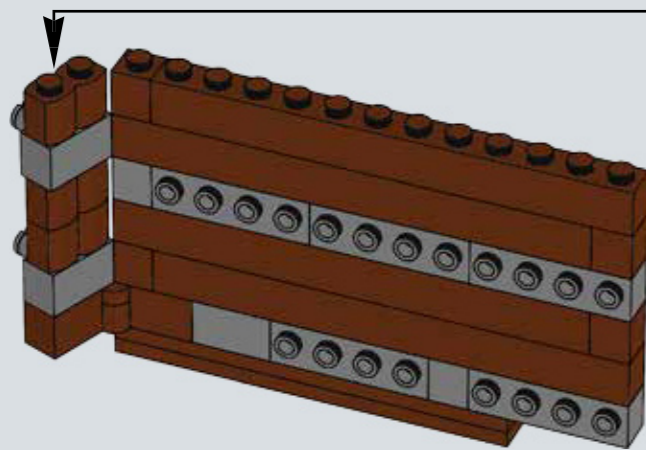
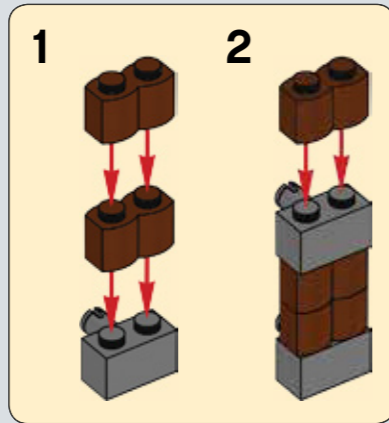

114

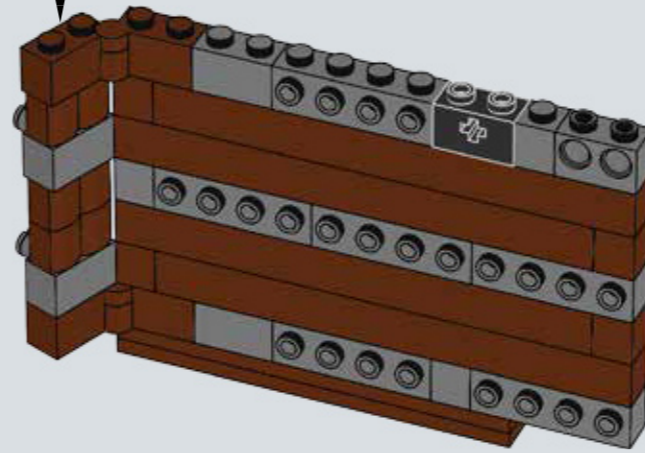
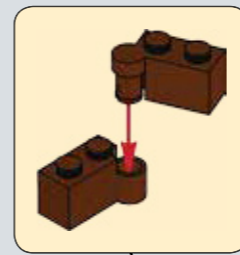

115

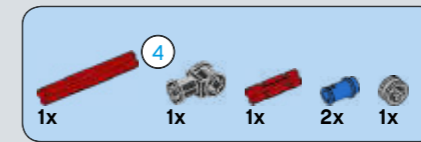
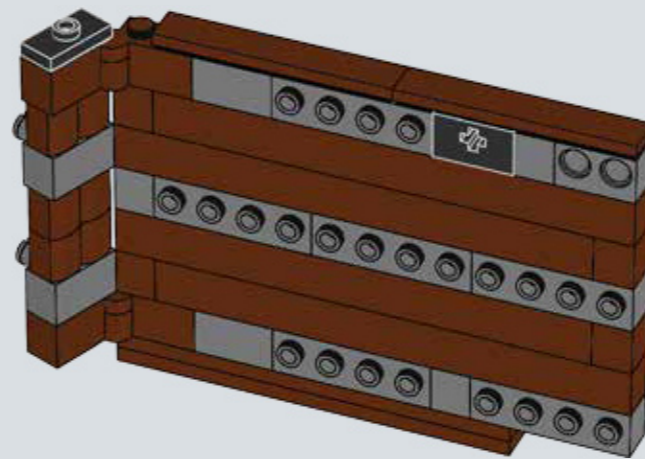

116

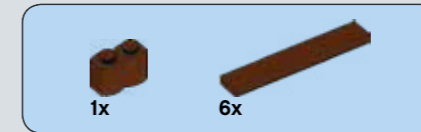
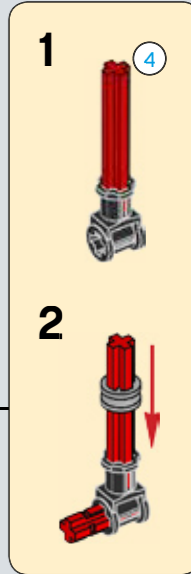
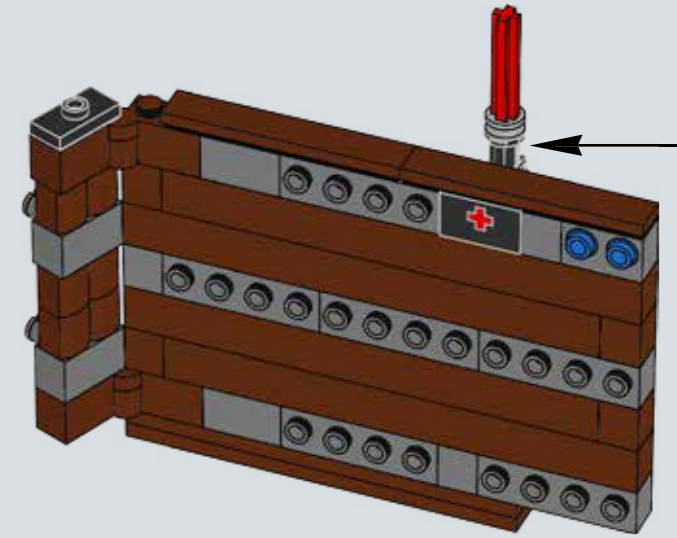
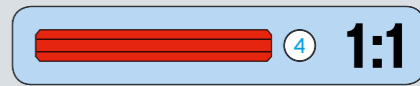

117

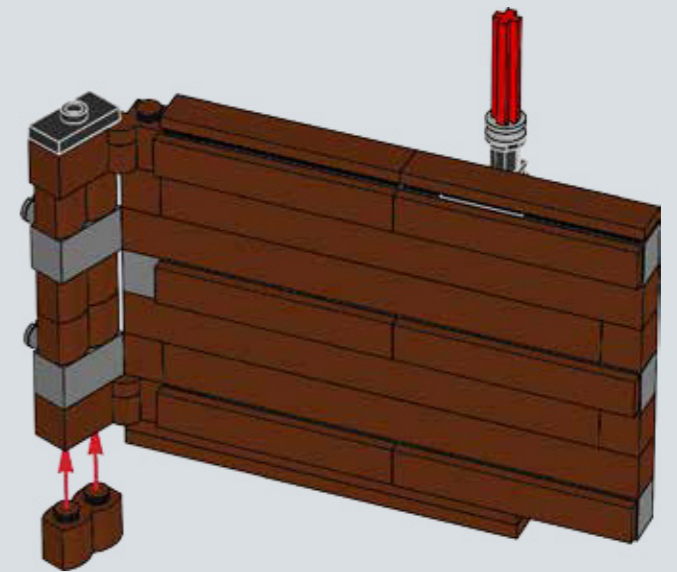

118

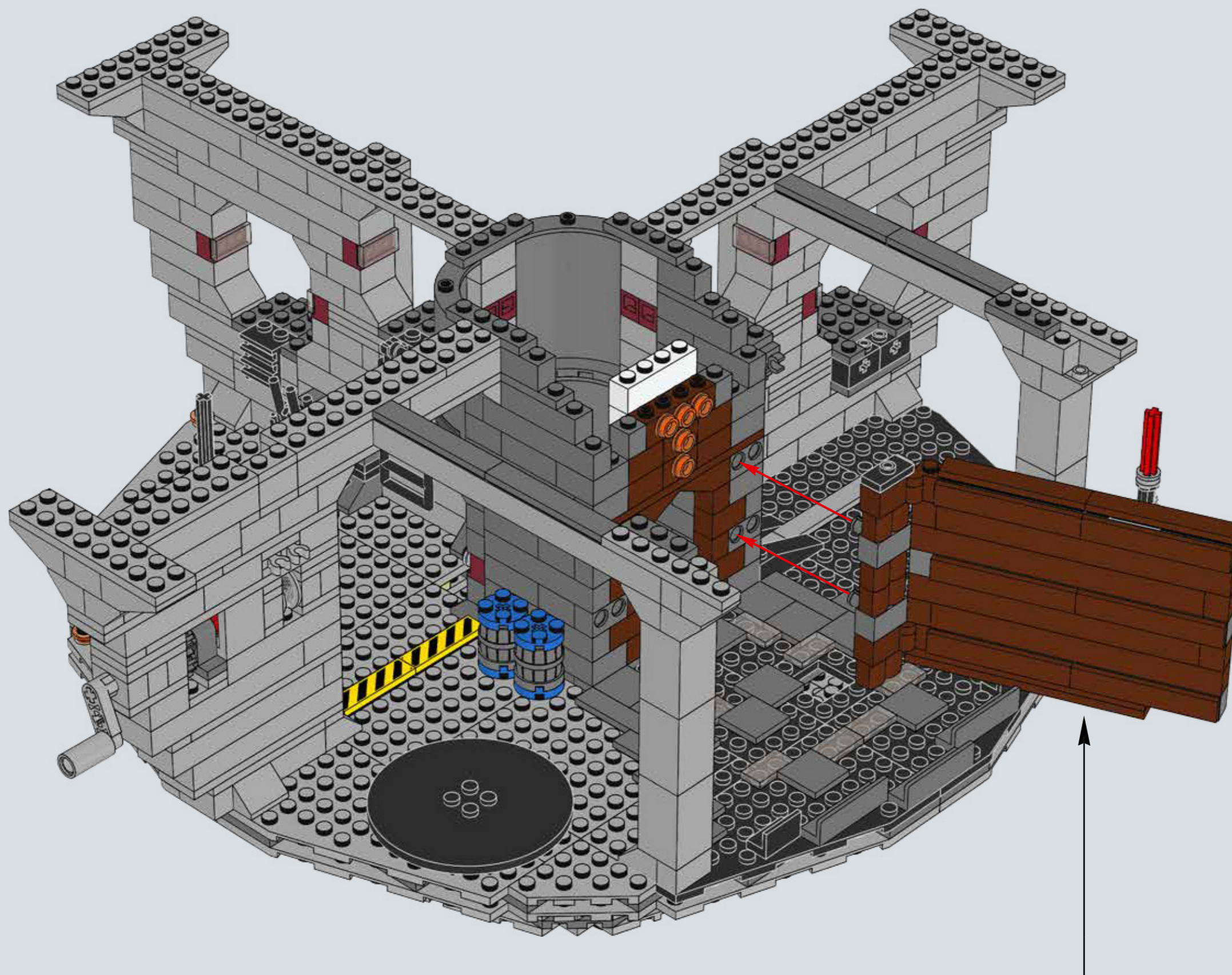

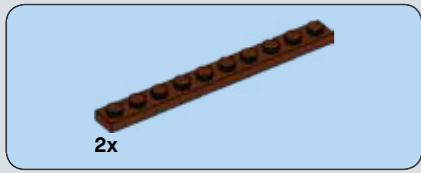
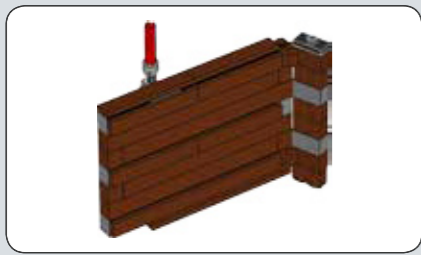

119

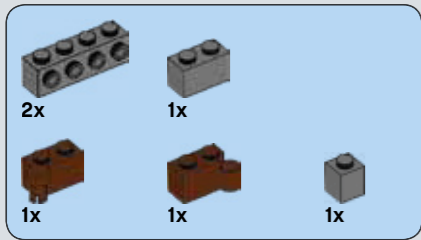
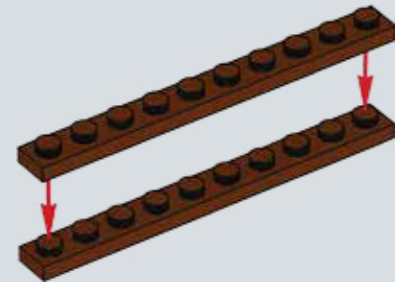

120

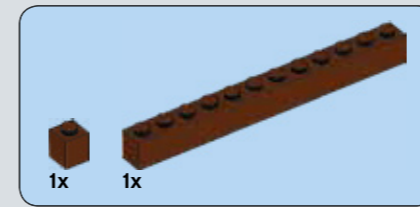
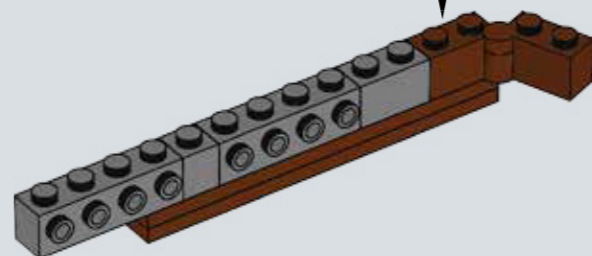
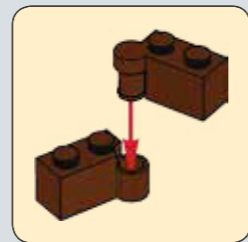

121

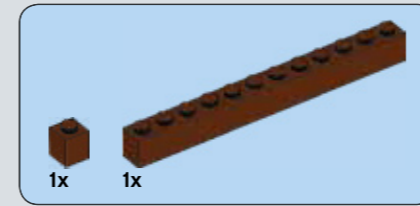
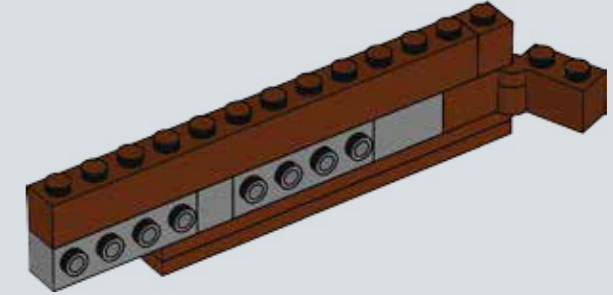

122

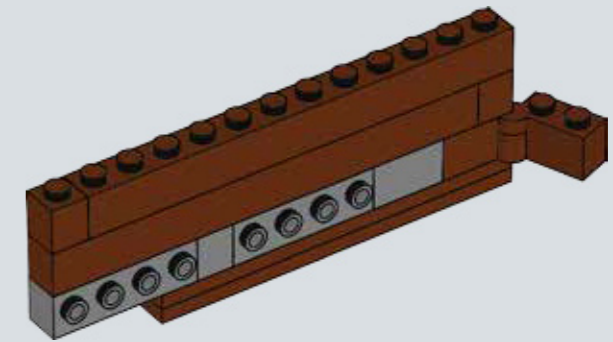

123

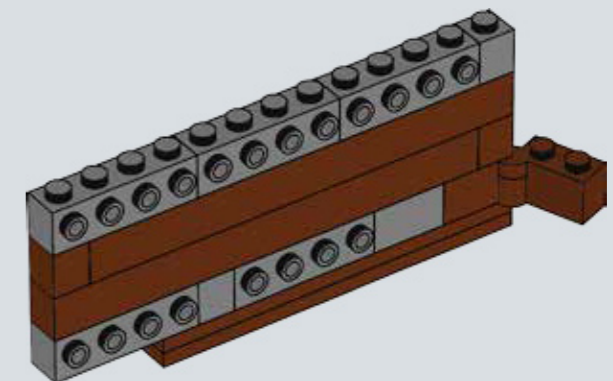

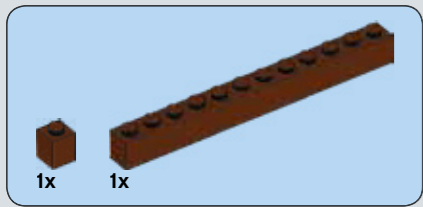

124

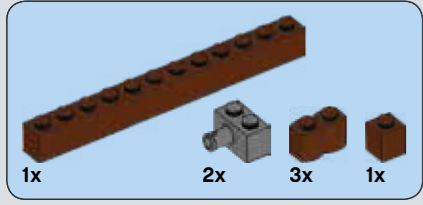
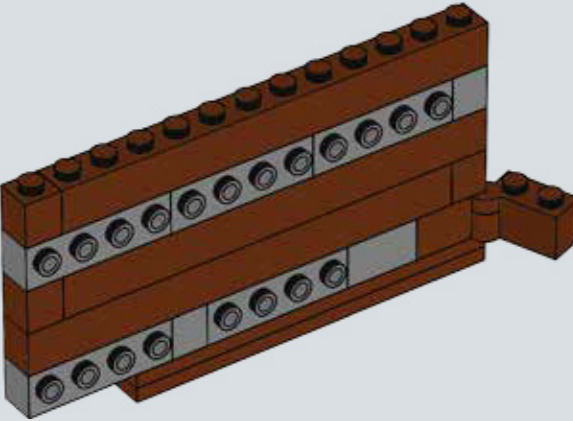

125

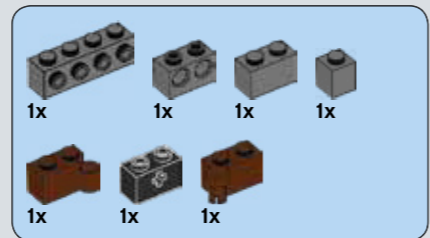
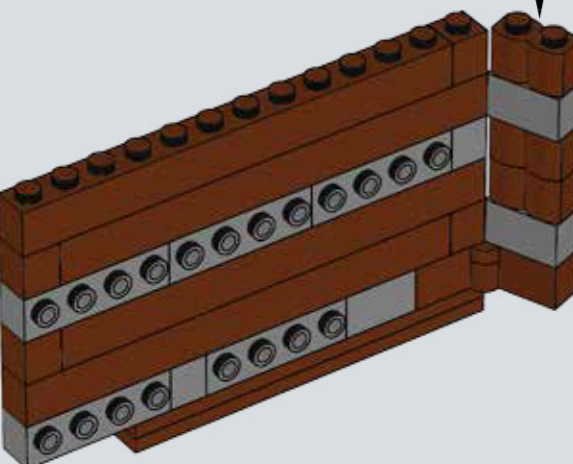
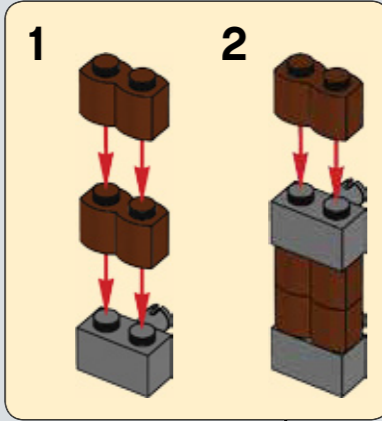

126

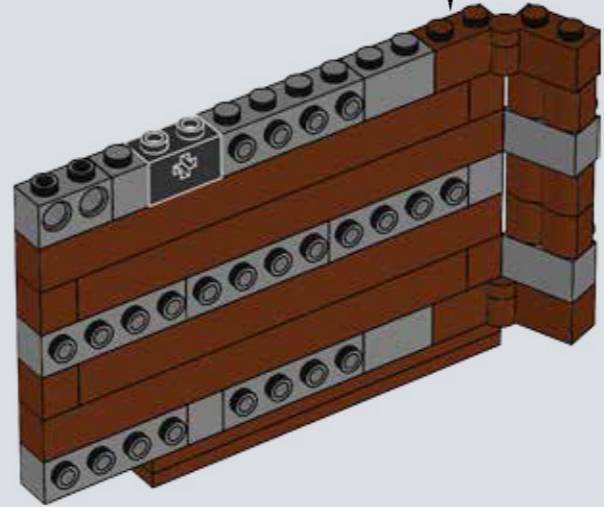
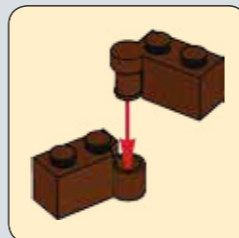

127

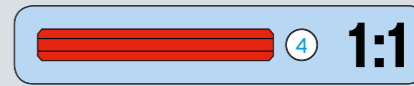
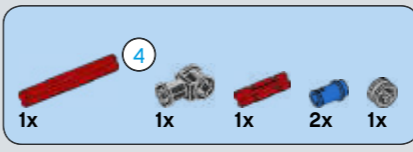
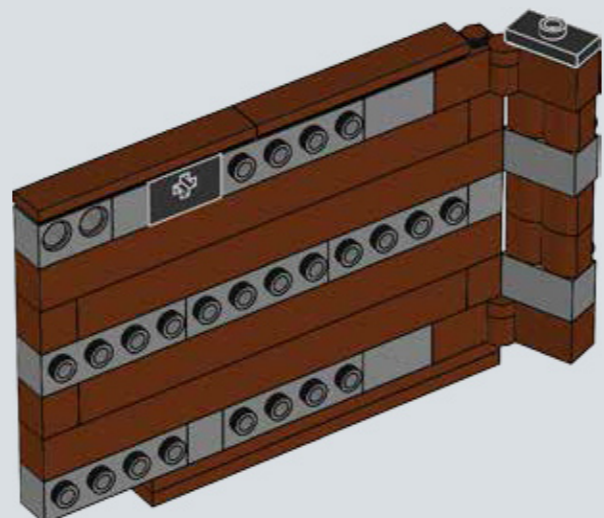

128

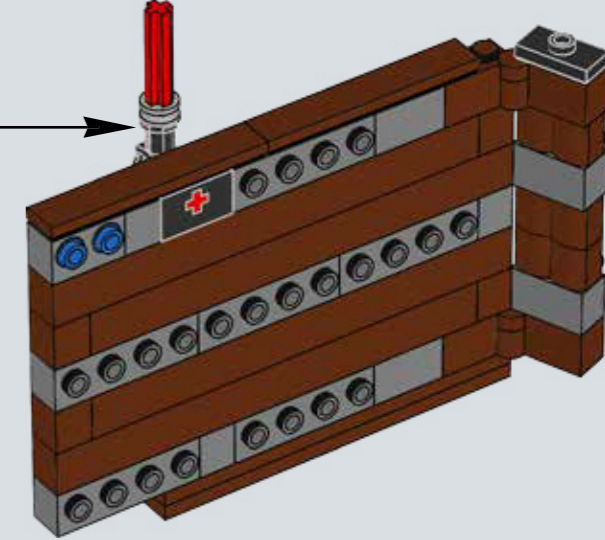
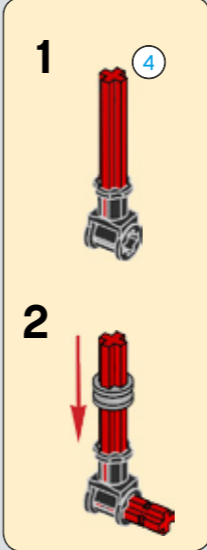

129

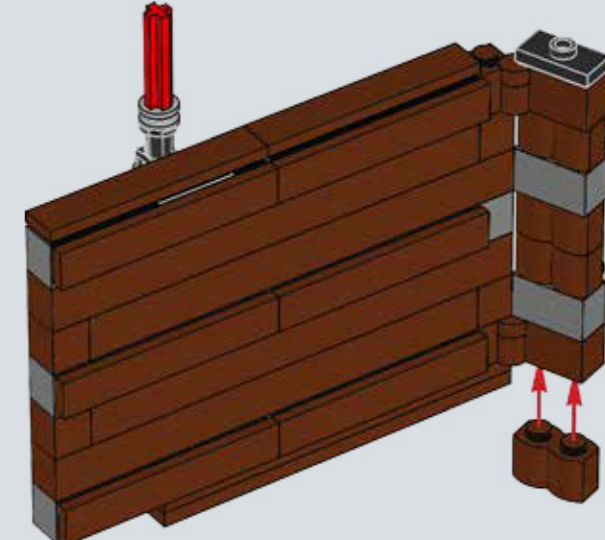

130

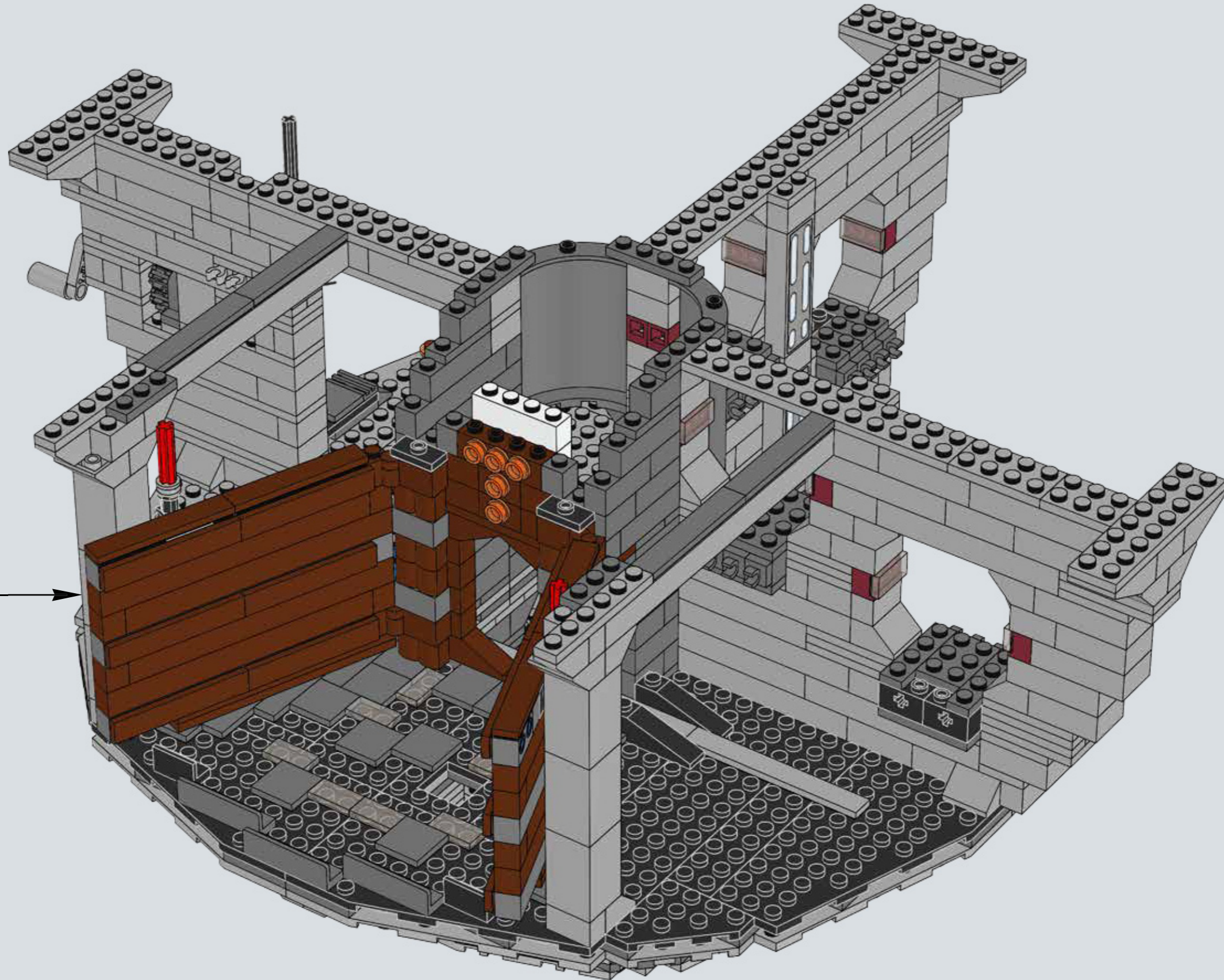
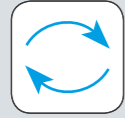

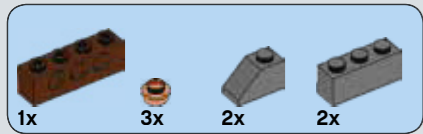

131

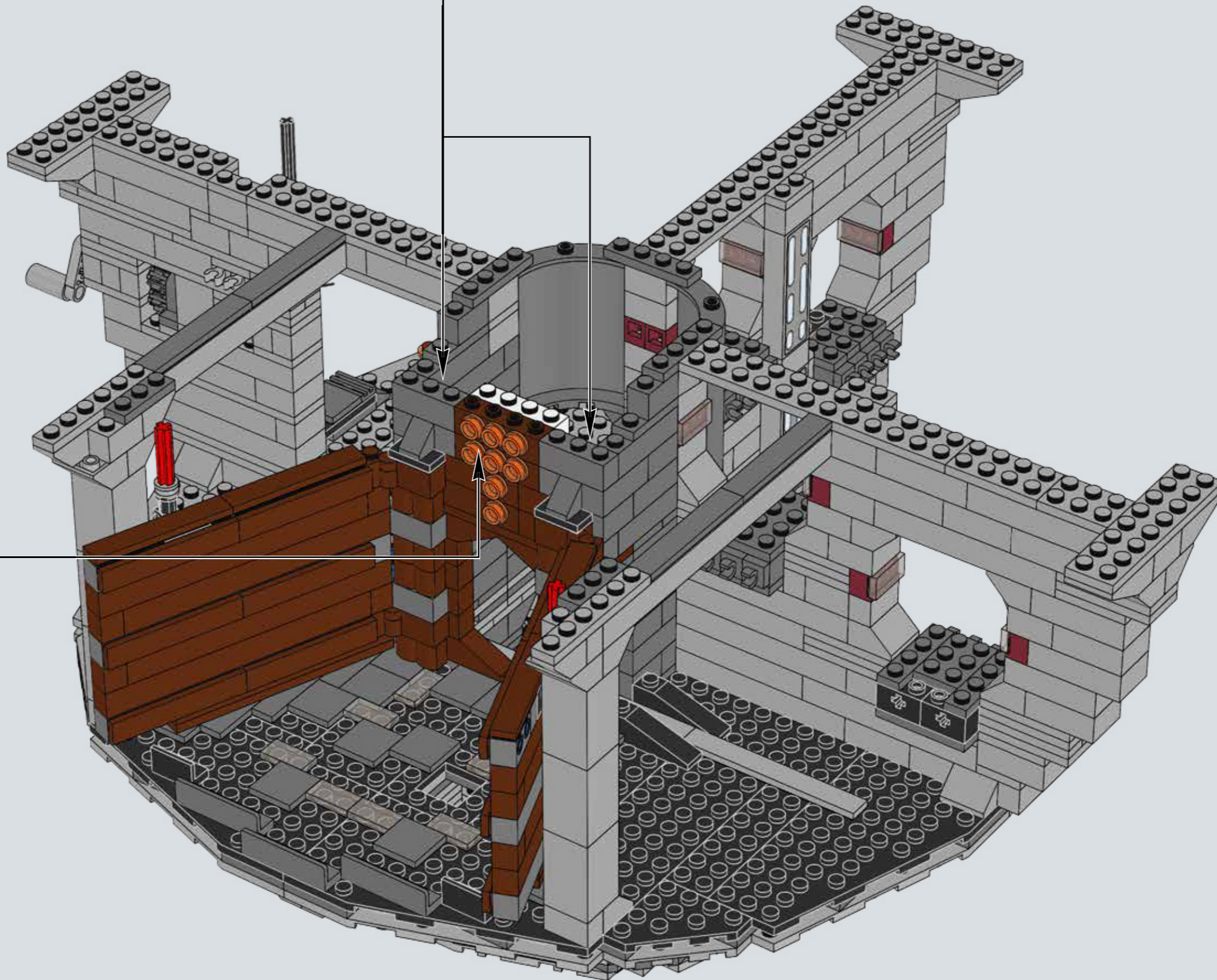
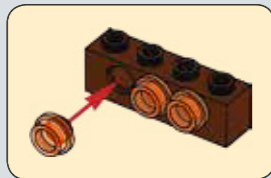
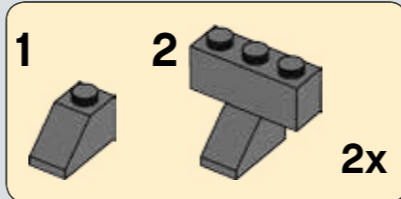



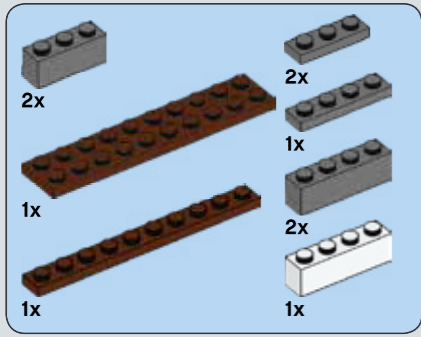

132

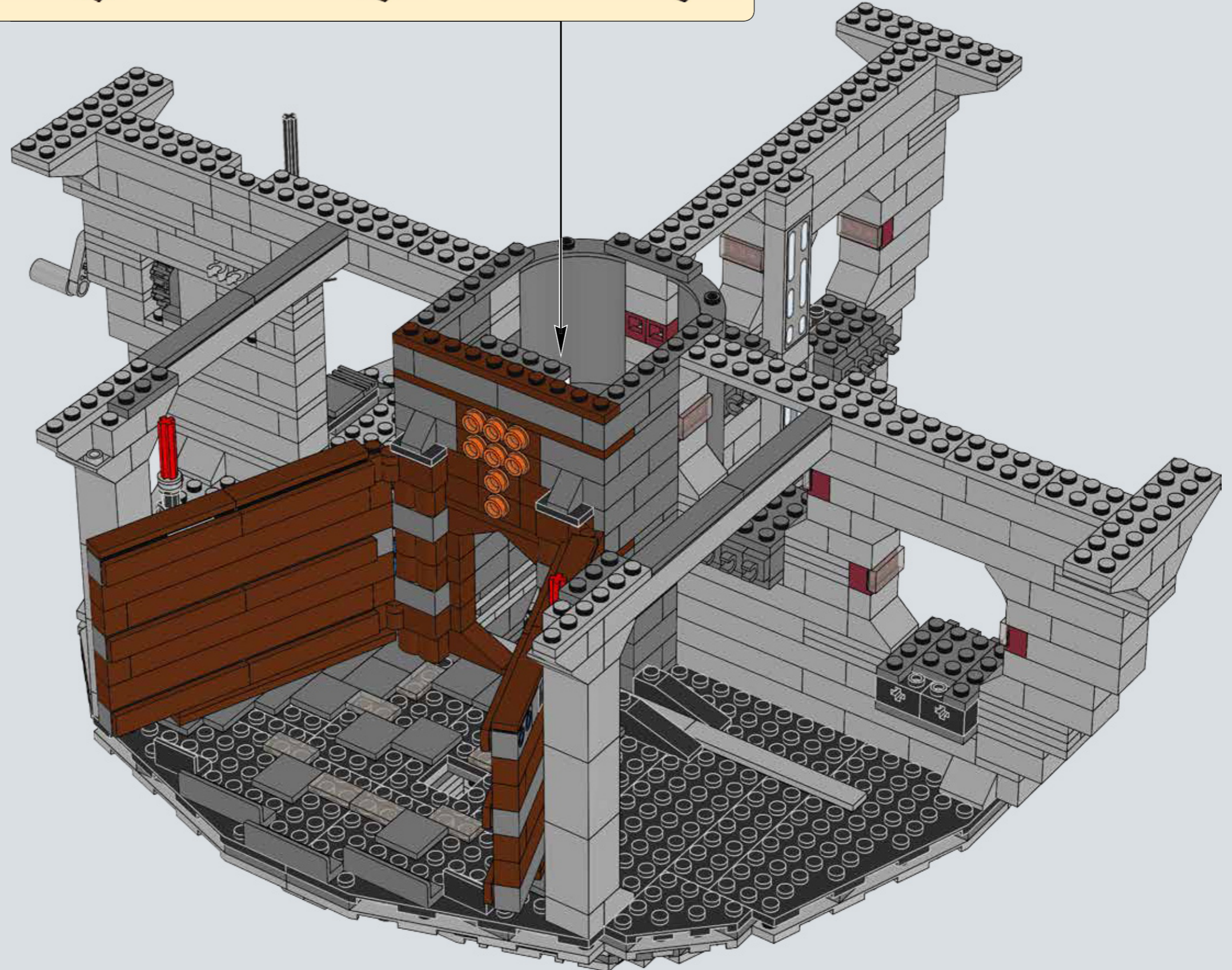
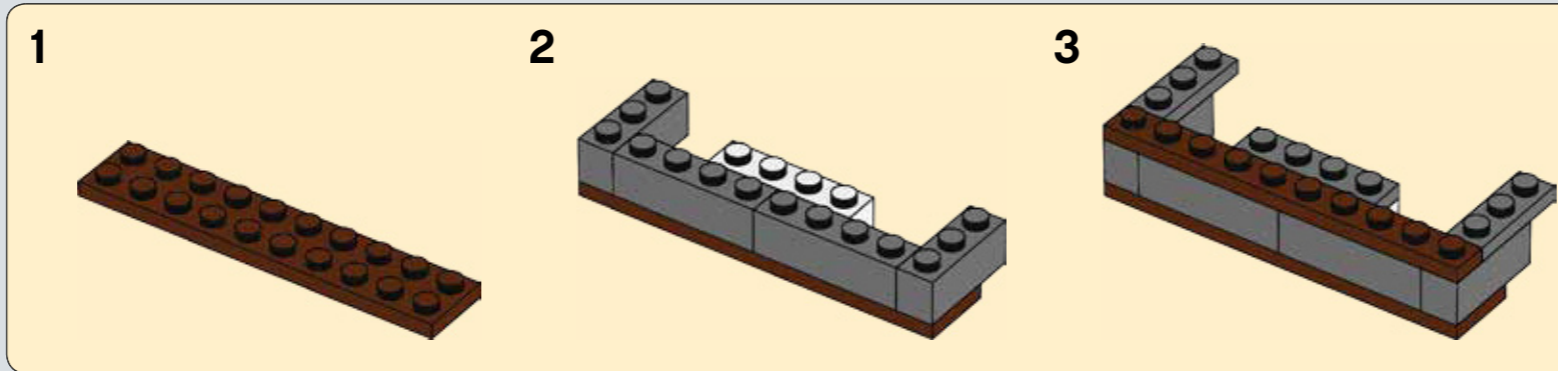

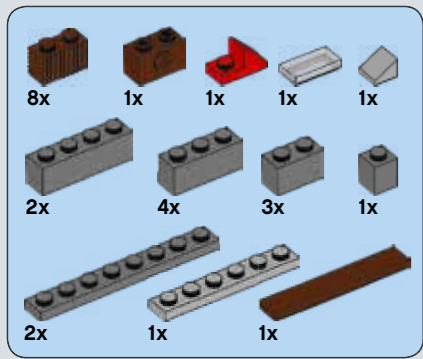

# 133

1

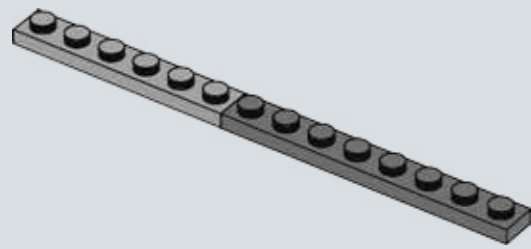

2

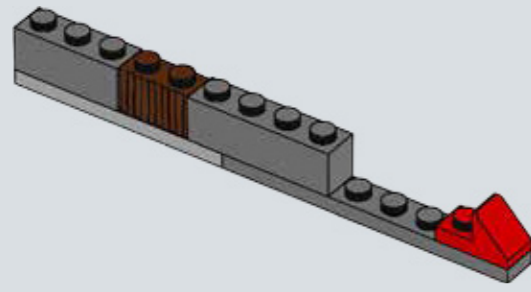

3

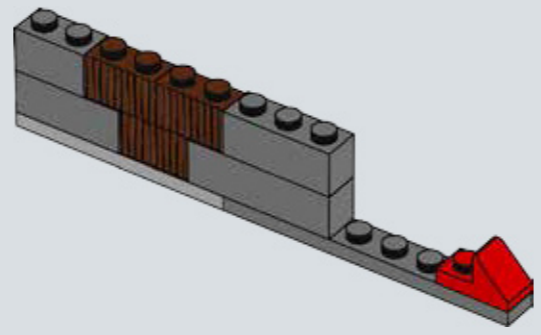

4

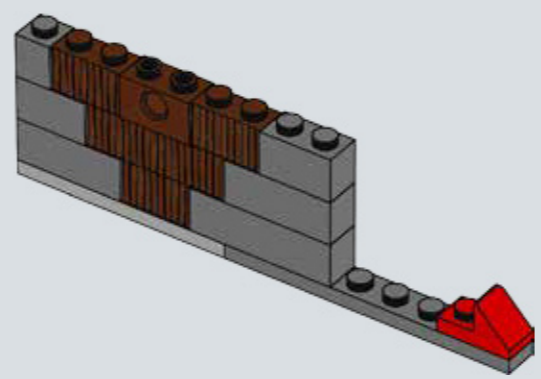

5

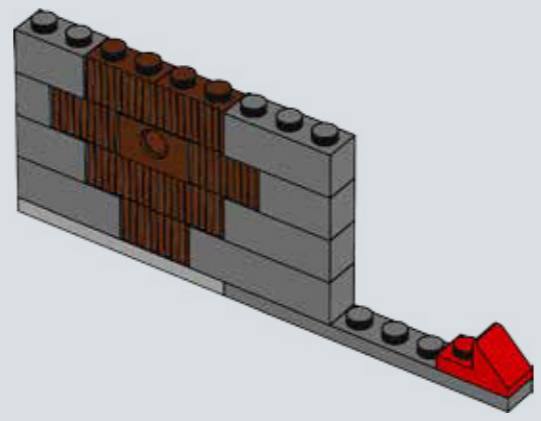

6

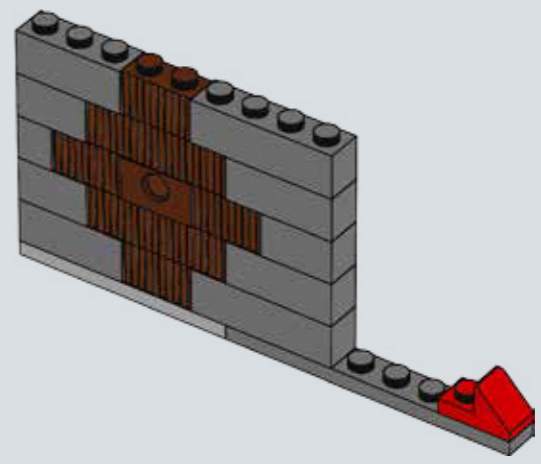

7

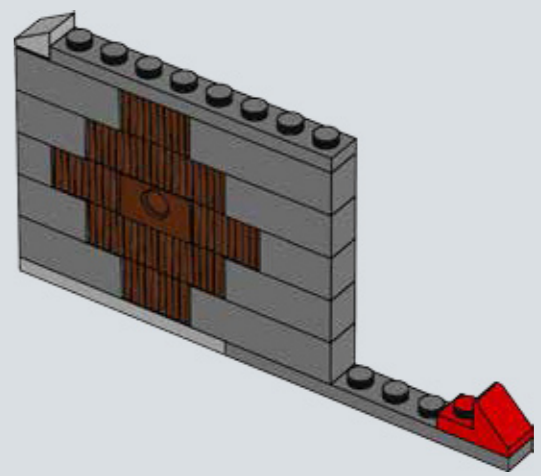

8

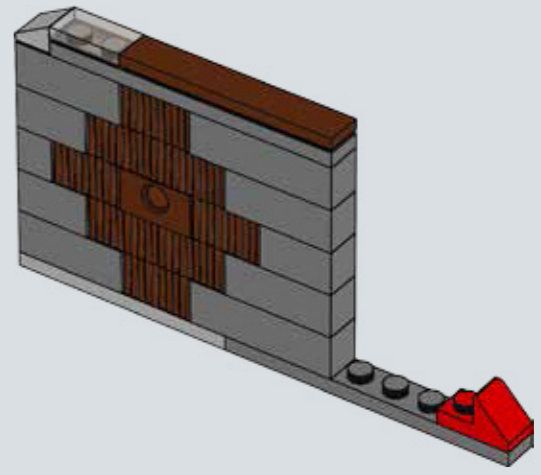

134

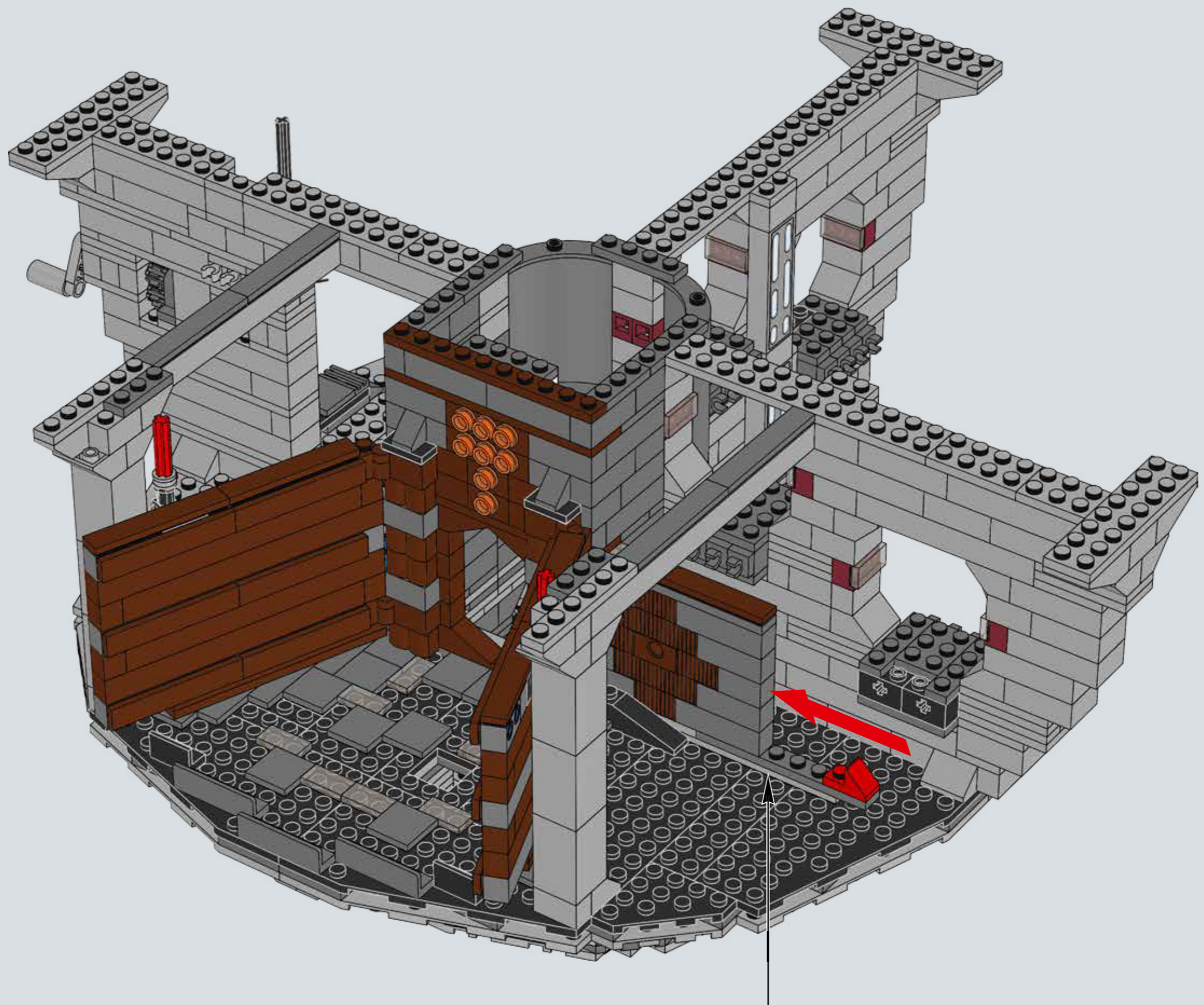

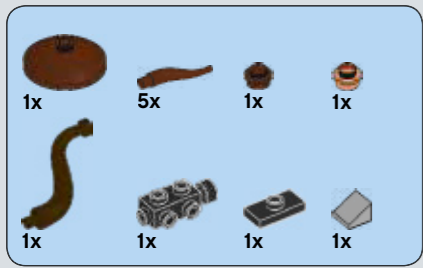

# 135

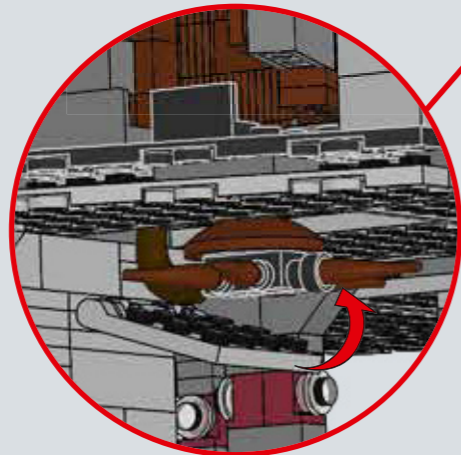
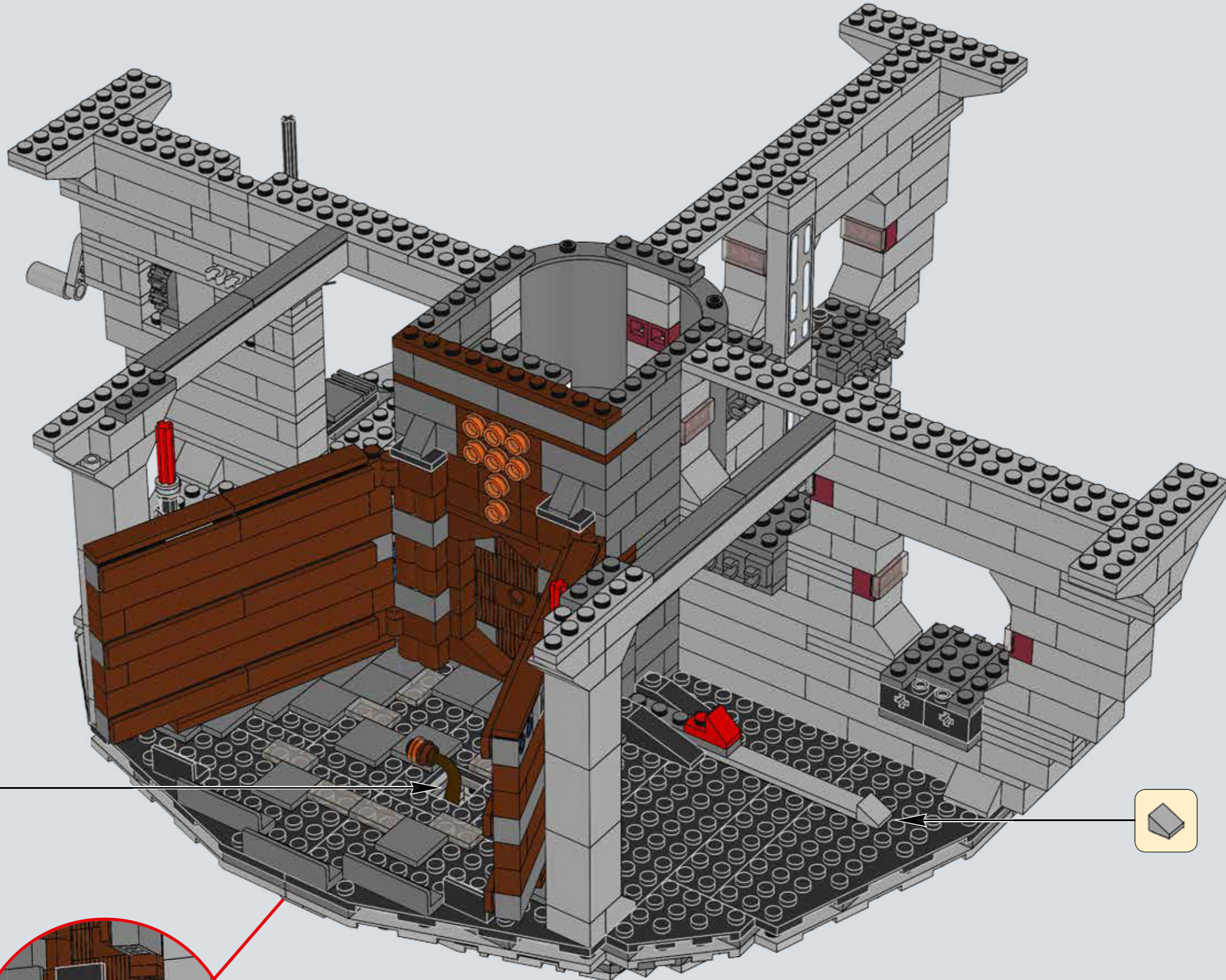
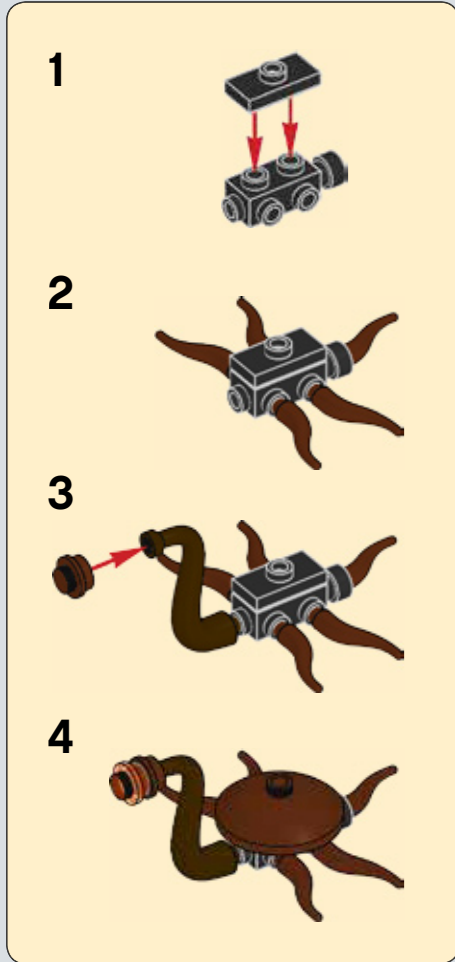

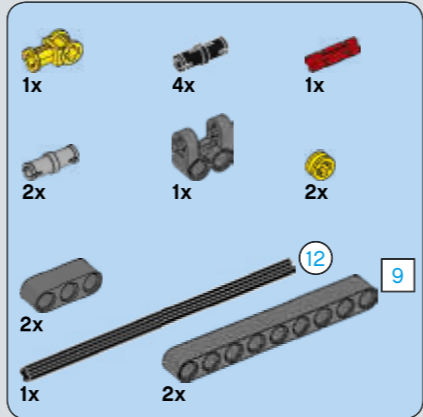
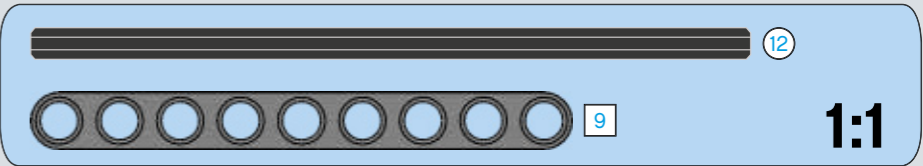
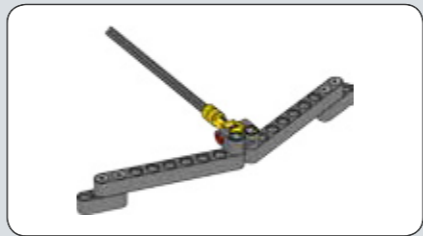
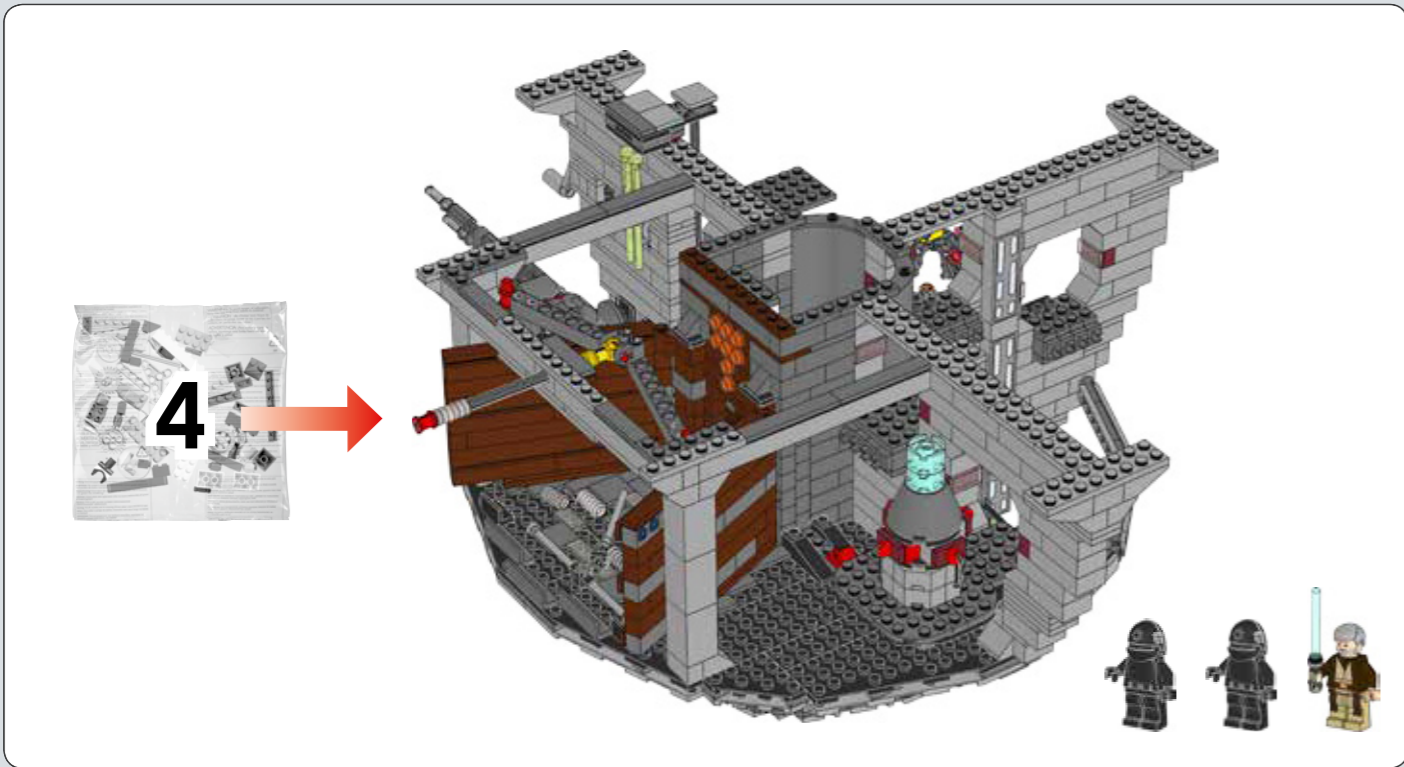

136

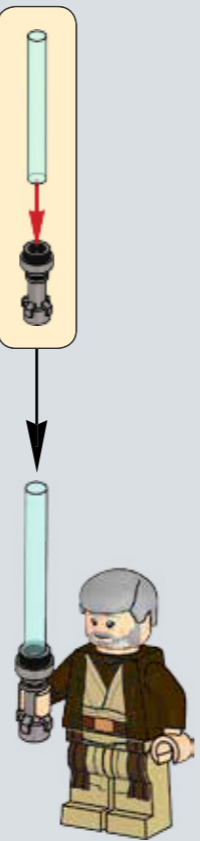
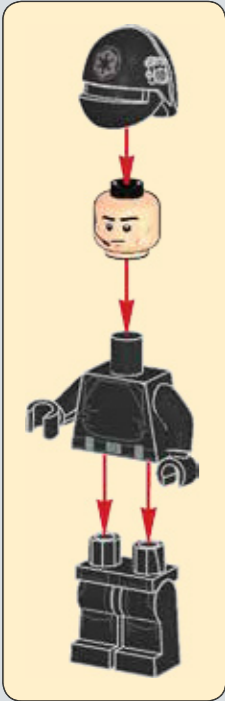
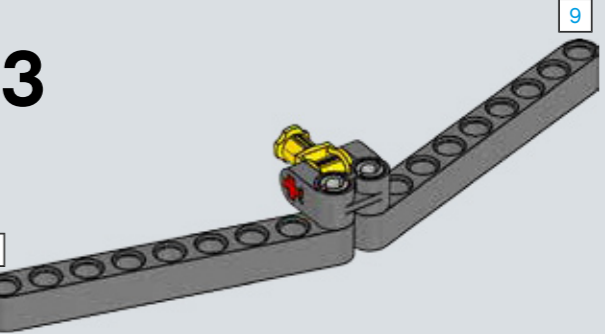
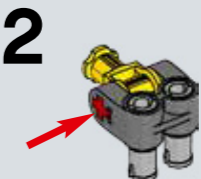
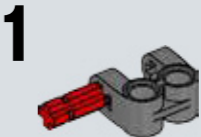

4

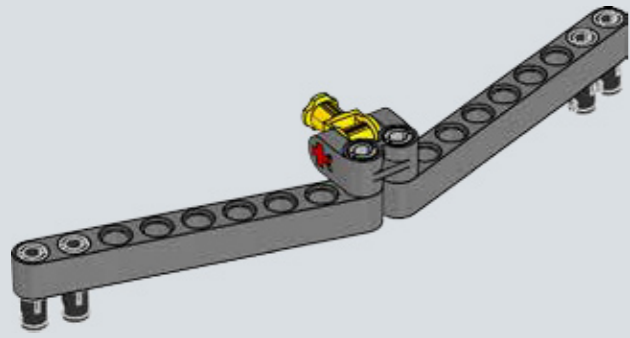

5

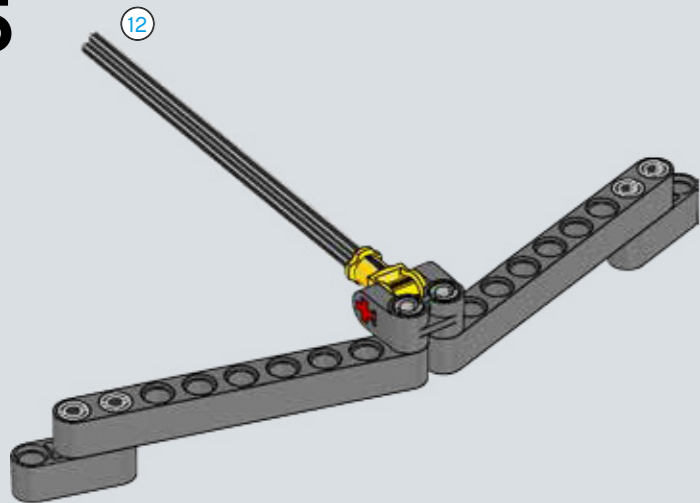

6

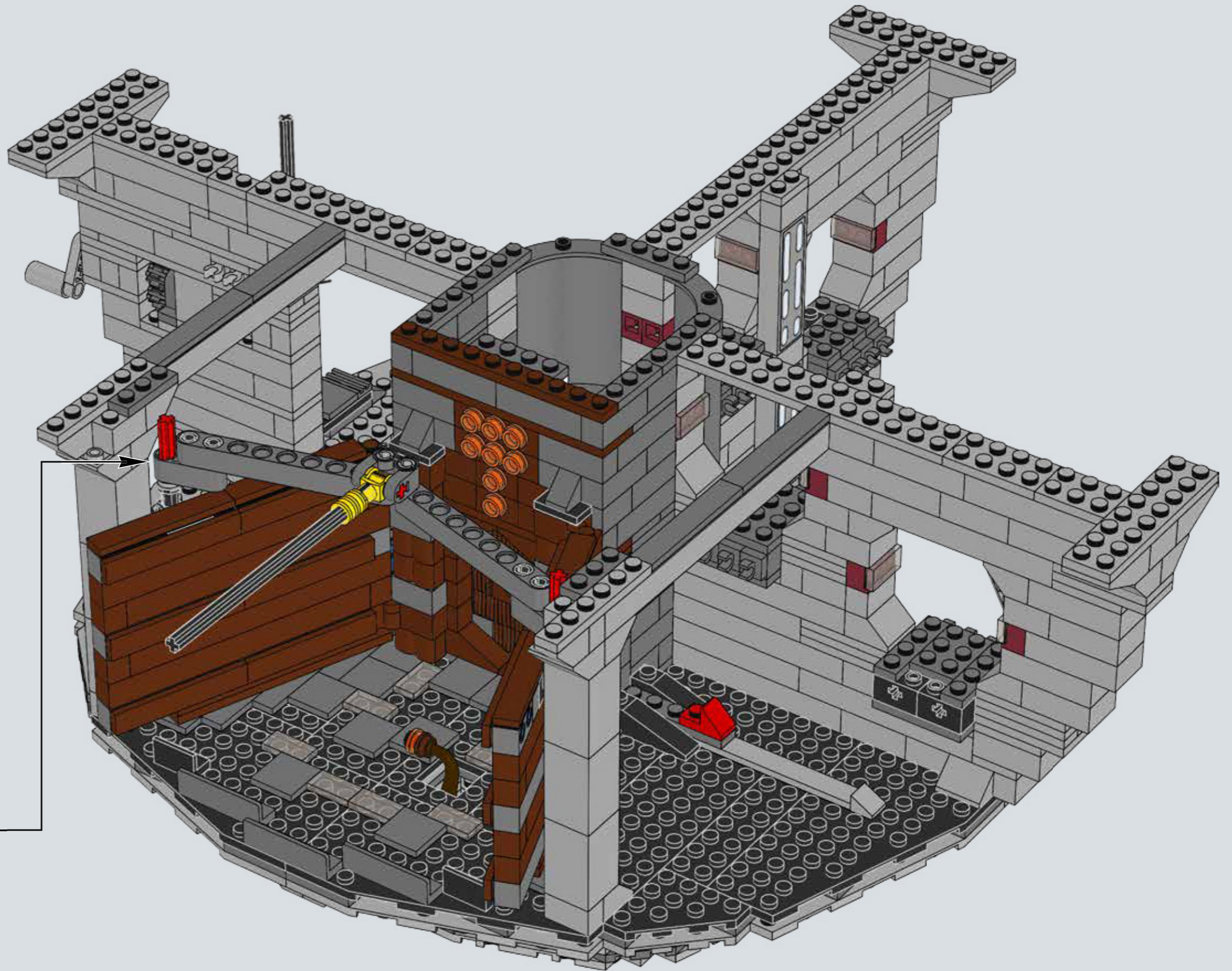
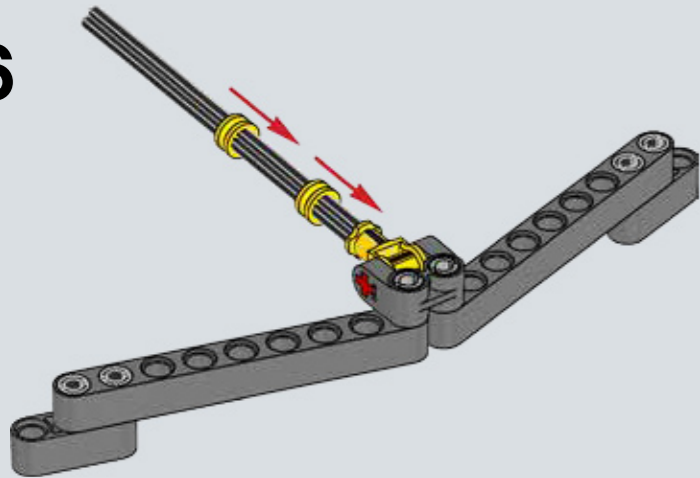

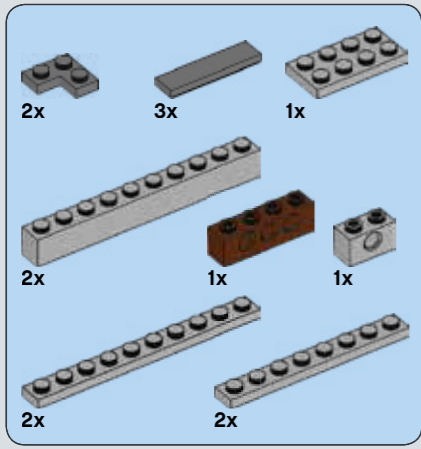

137

1

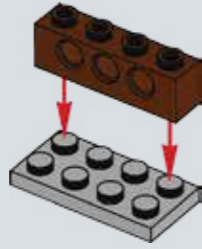

2

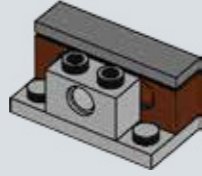

3

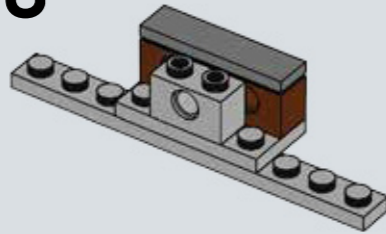

4

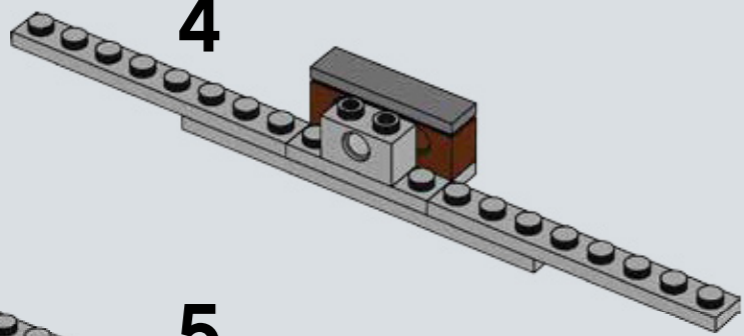

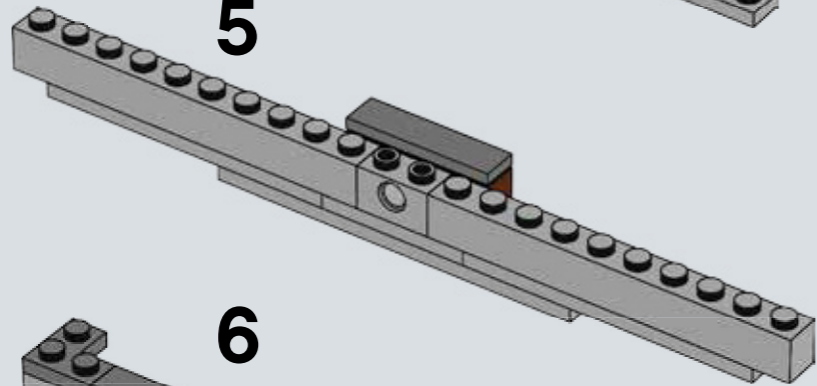

5

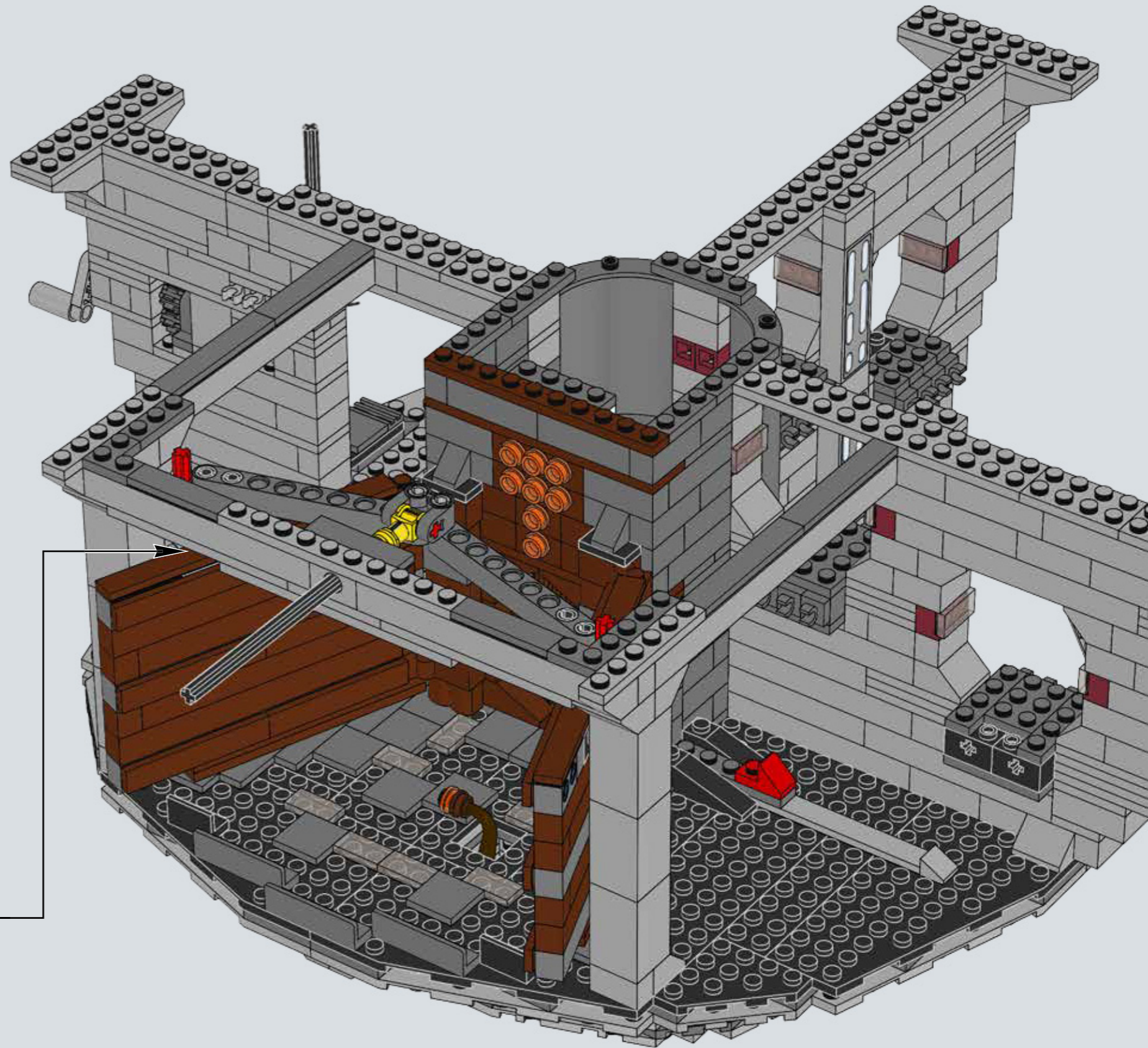
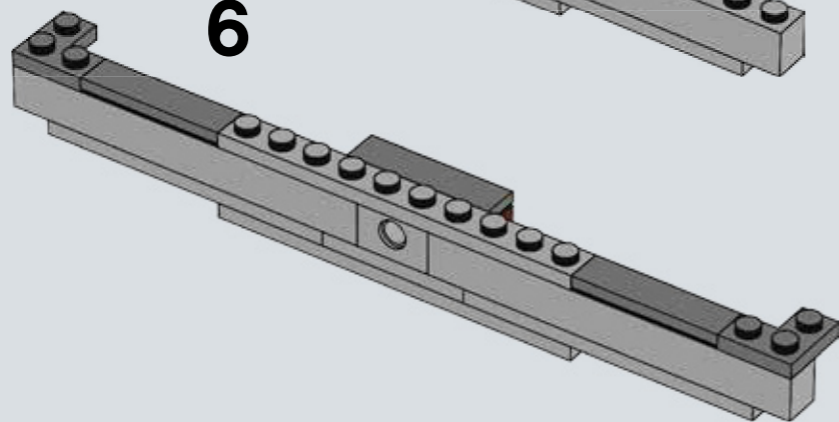

6



3x  1x 

138

 2x

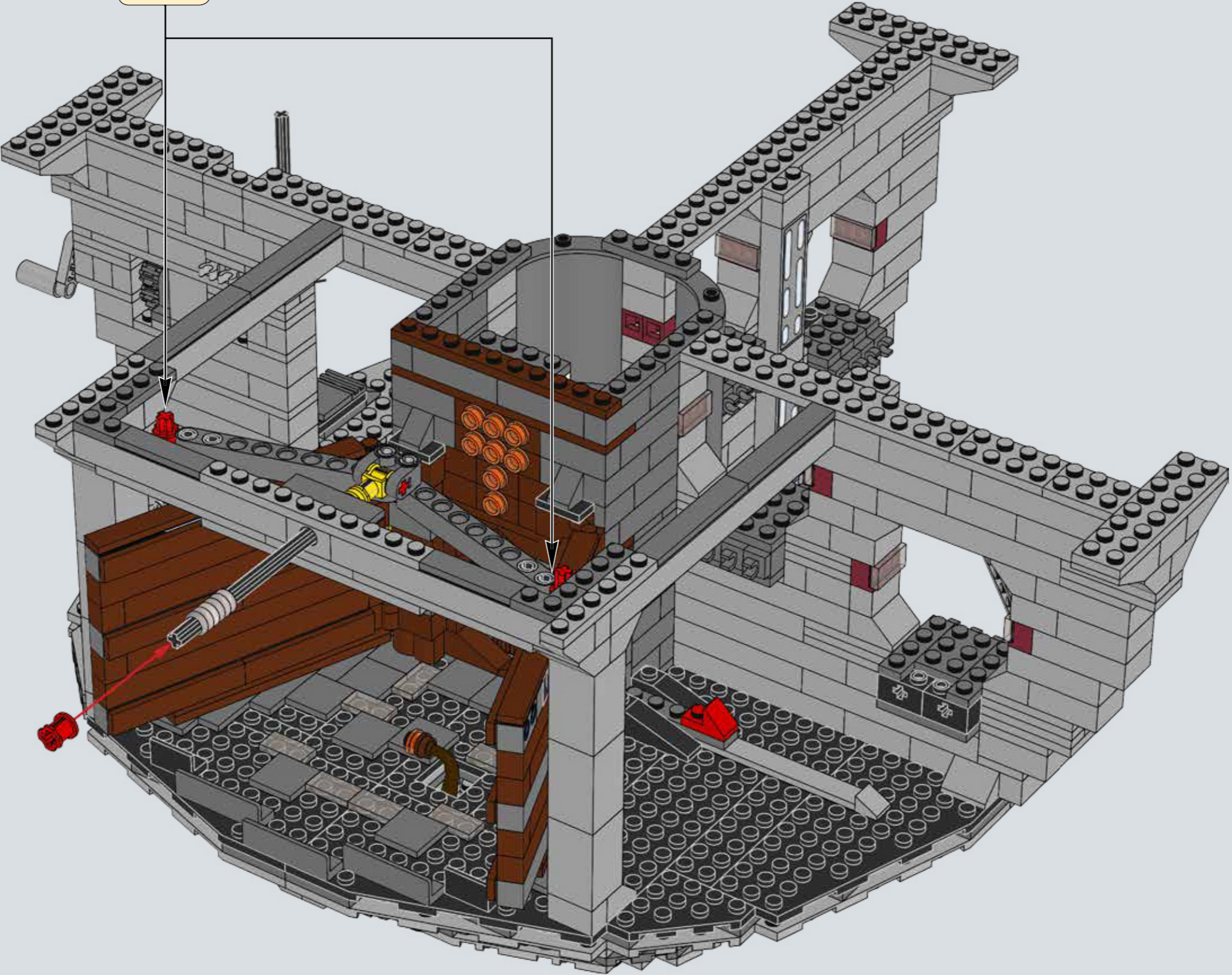



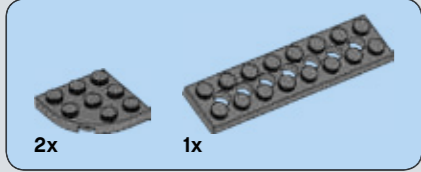
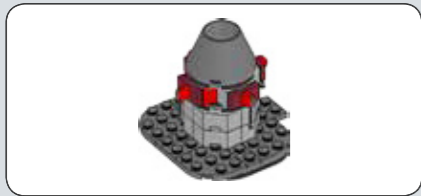

139

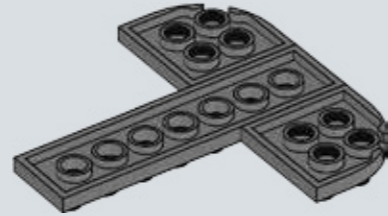

140

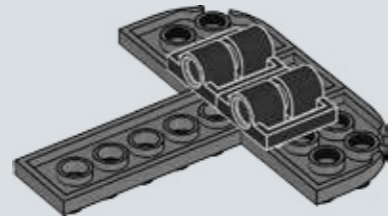

141

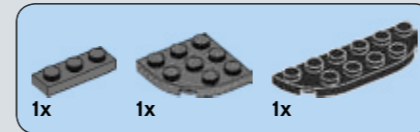
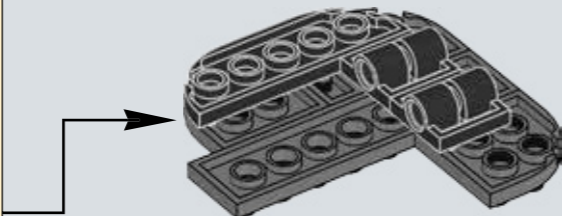
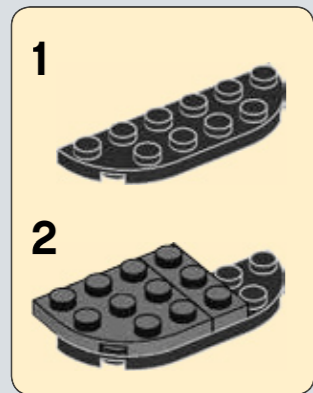

142

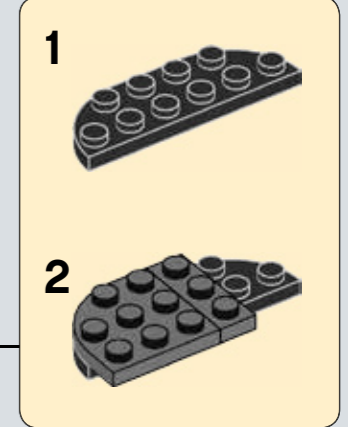
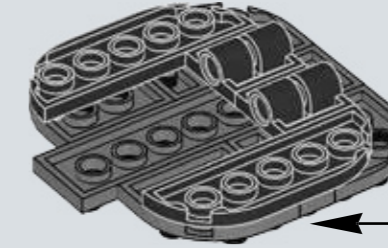

143

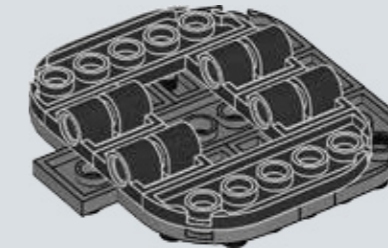

144

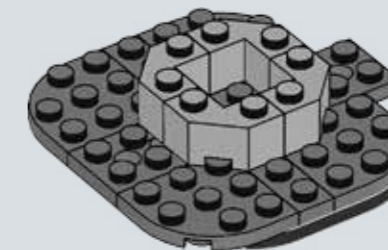
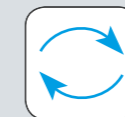

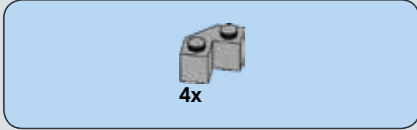

145

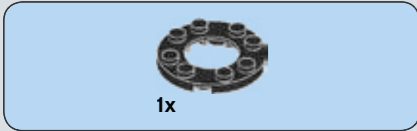
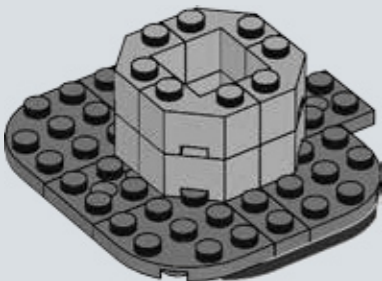

146

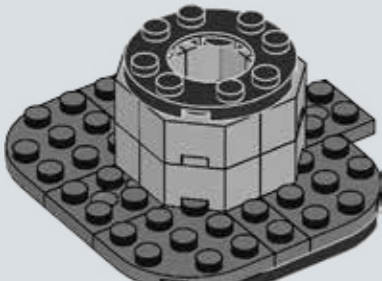

147

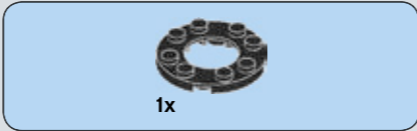
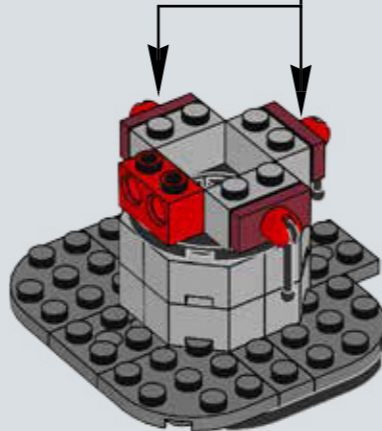
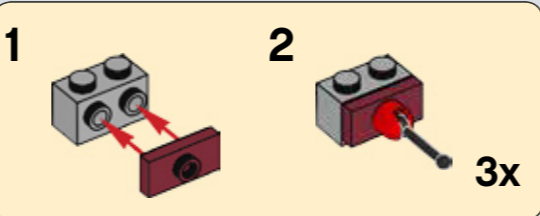

148

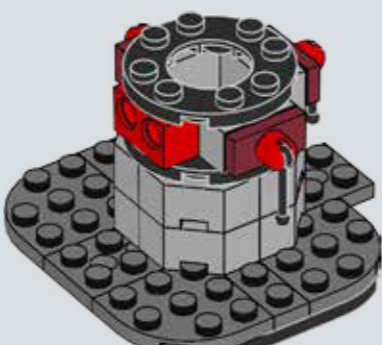

149

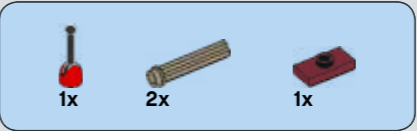
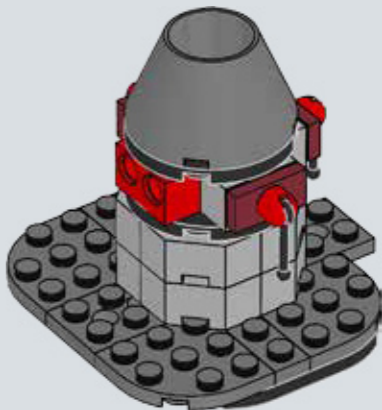

150

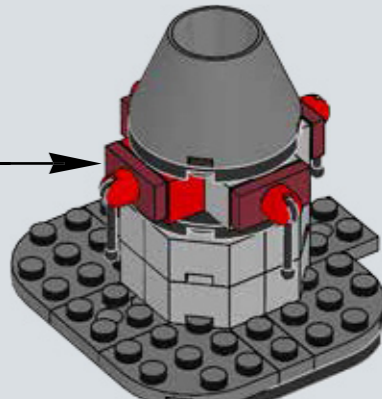
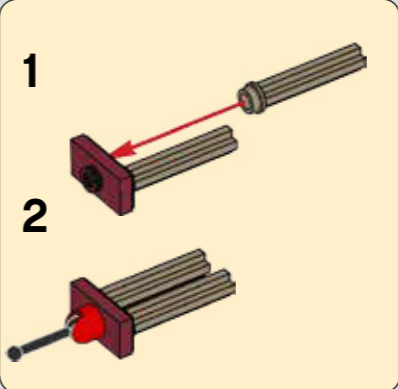

151

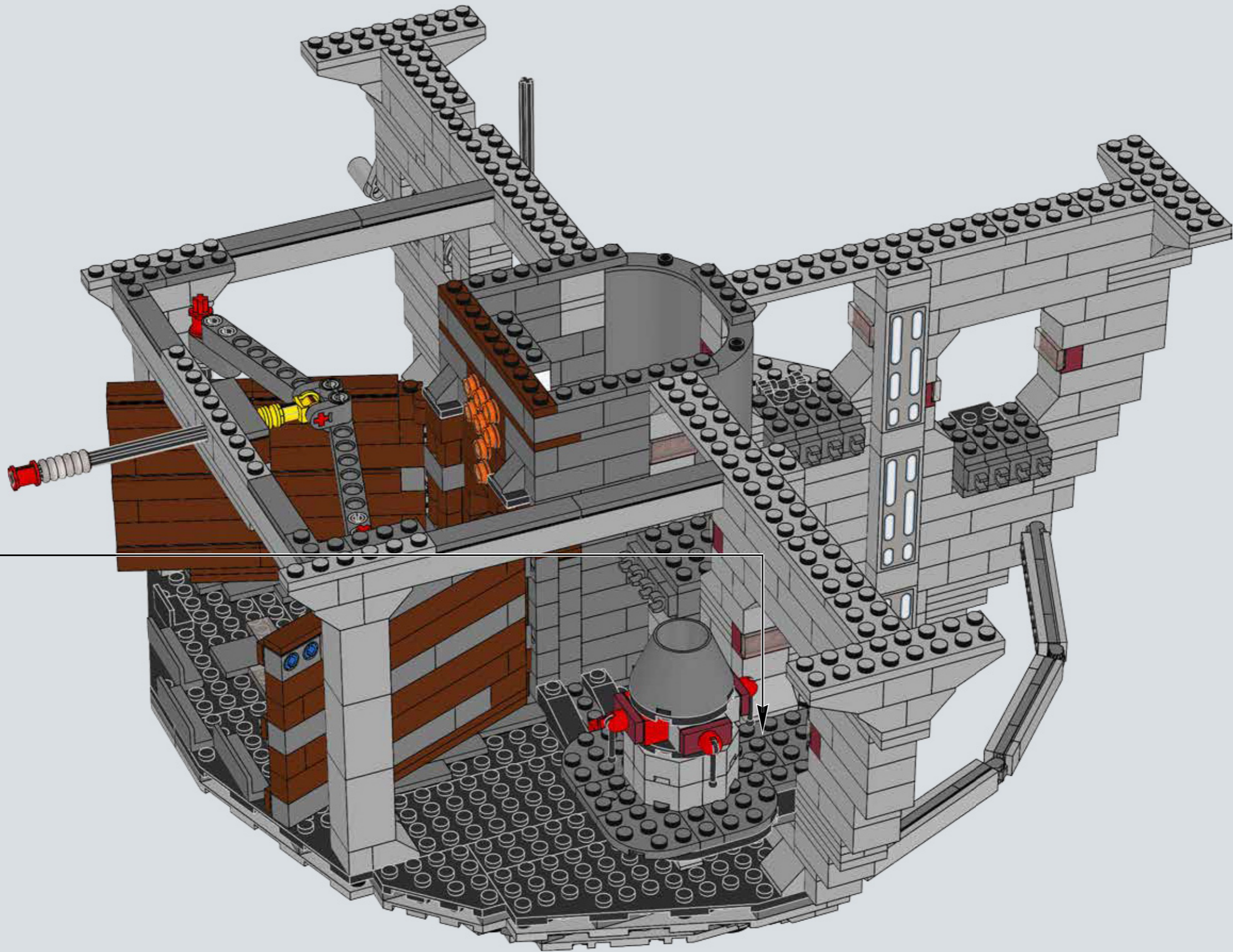

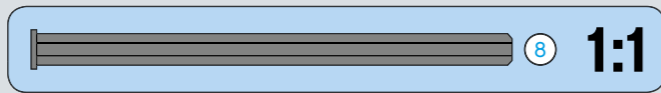
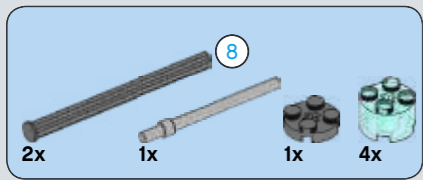

152

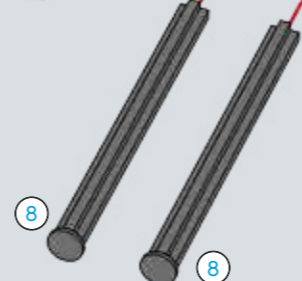
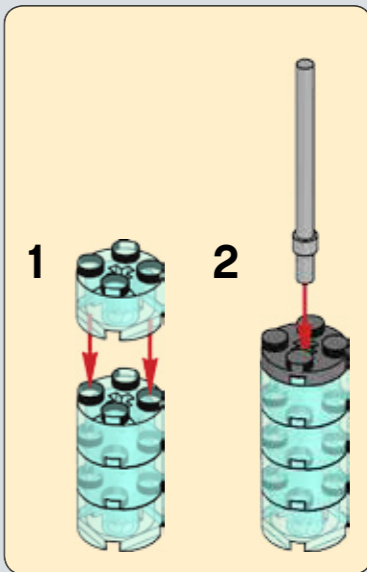
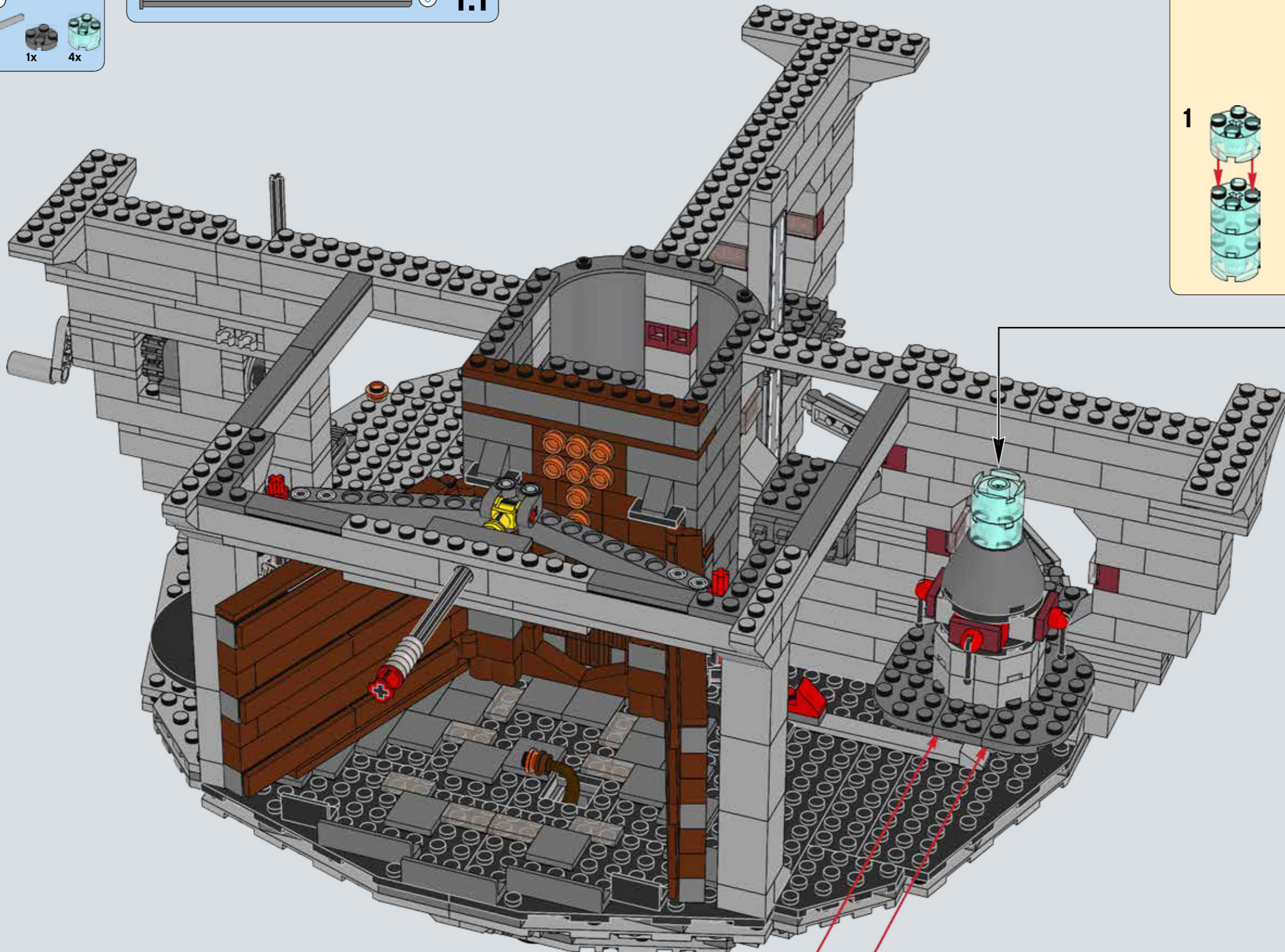

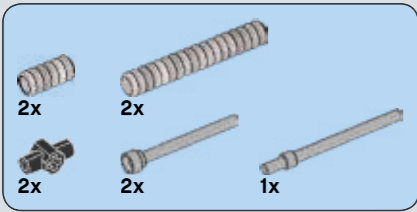

153

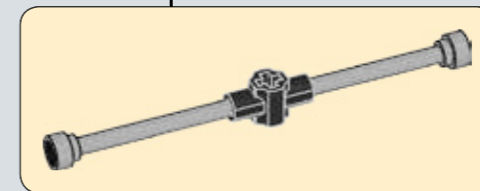
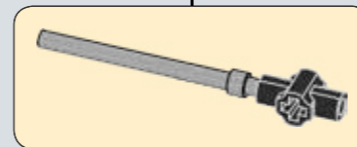
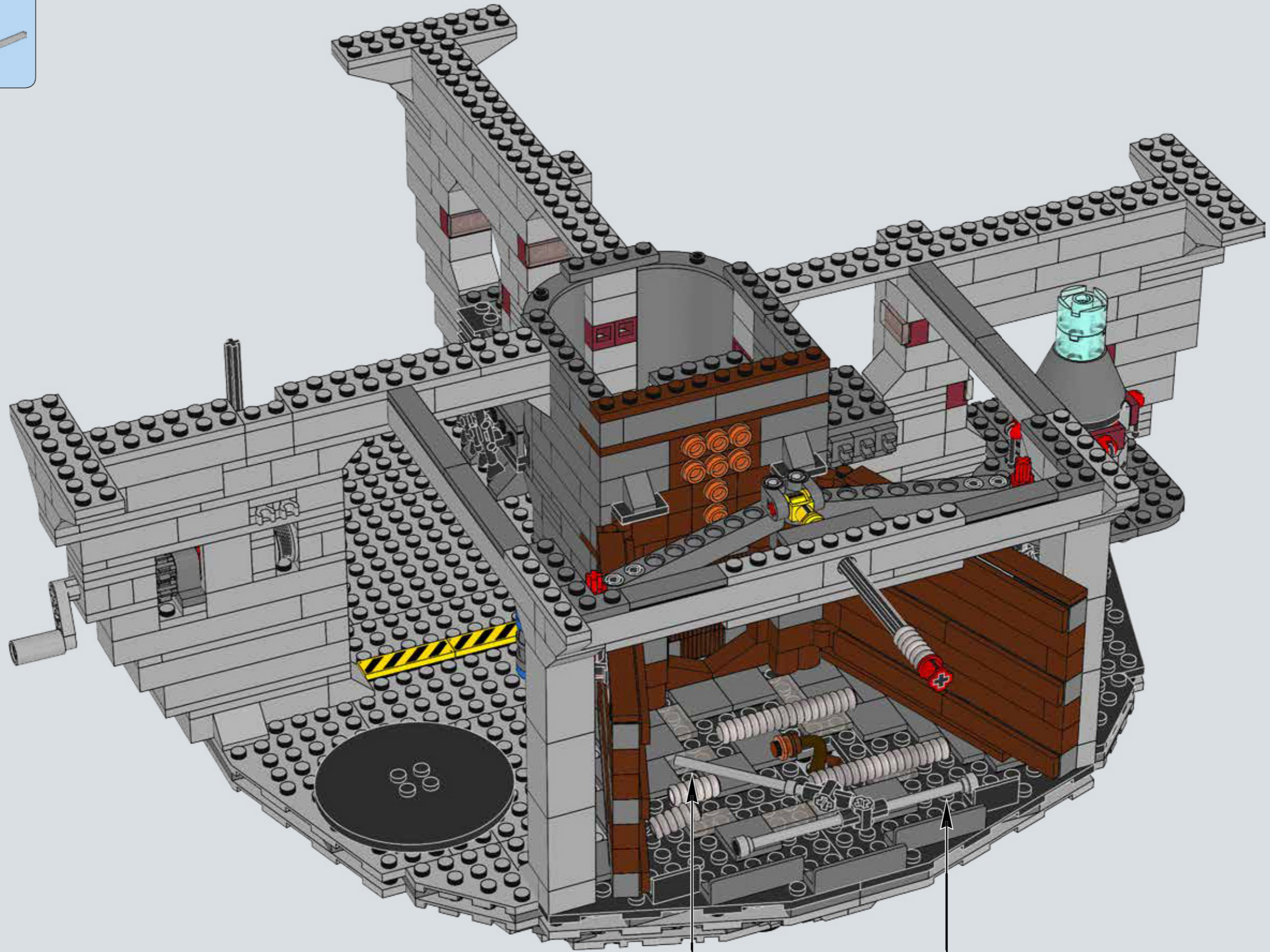

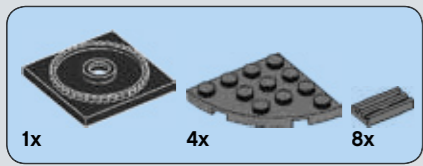

# 154

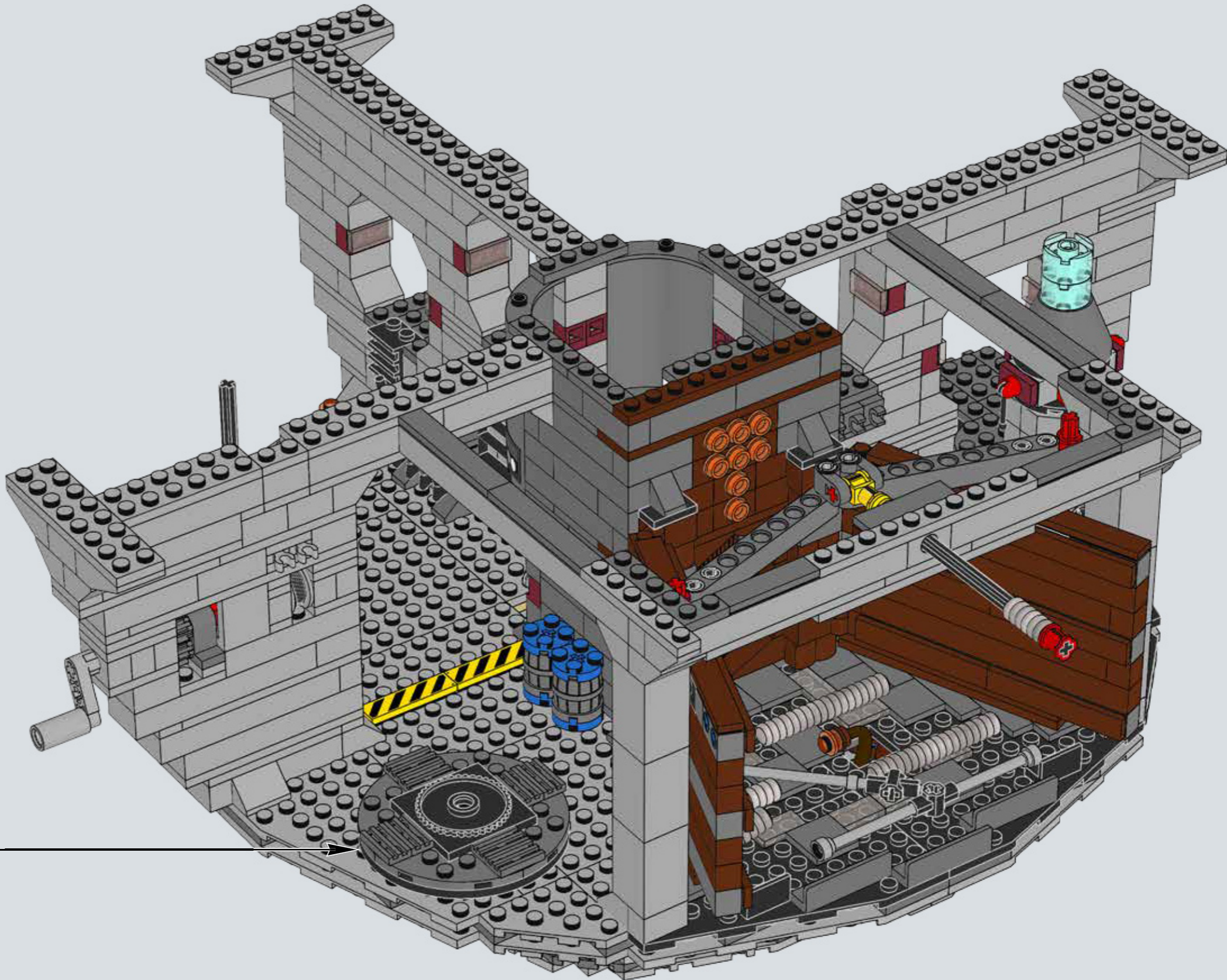
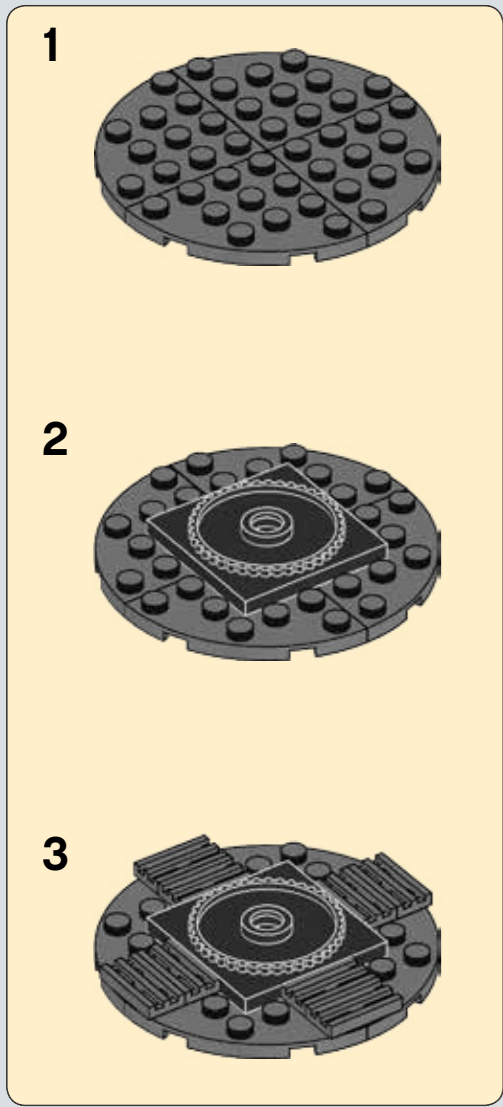

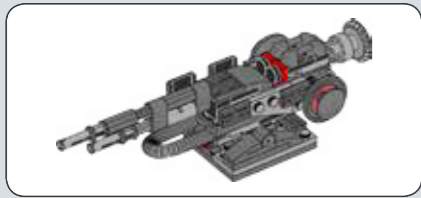

155



156

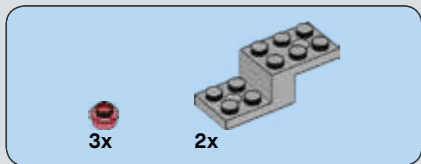

157

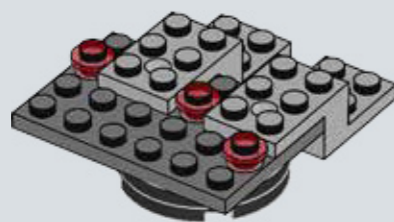

158

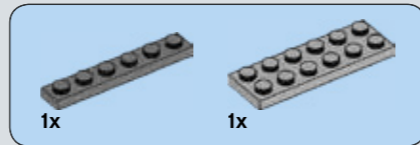
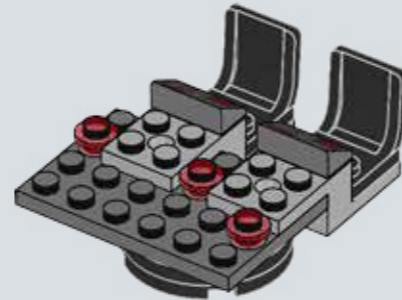

159

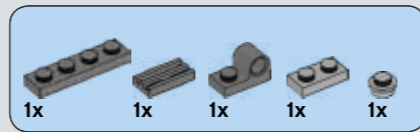
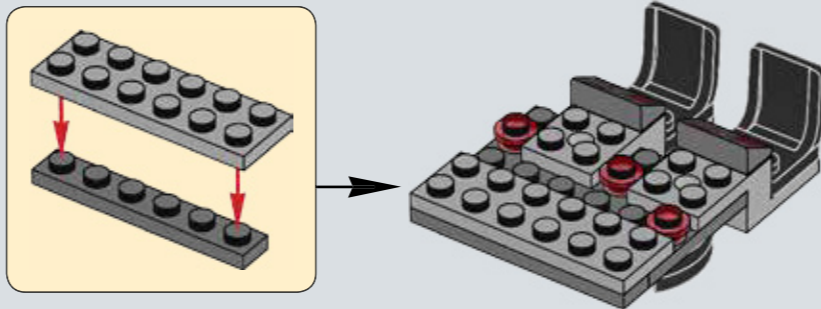

160

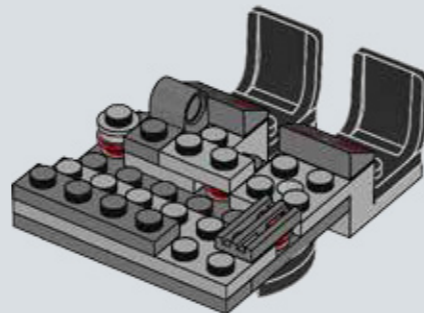

161

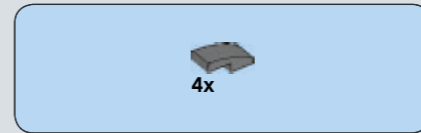
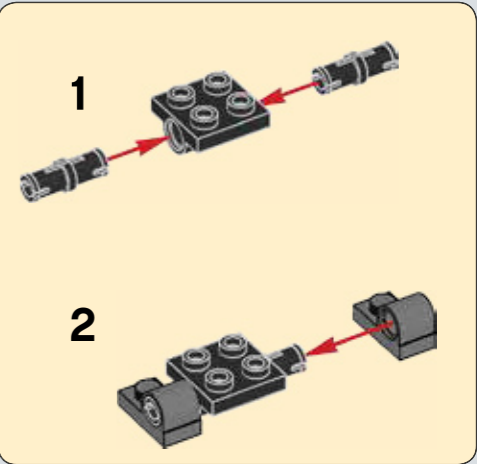
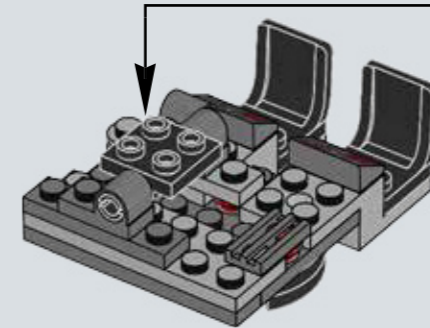

162

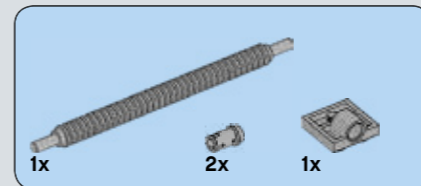
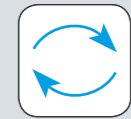
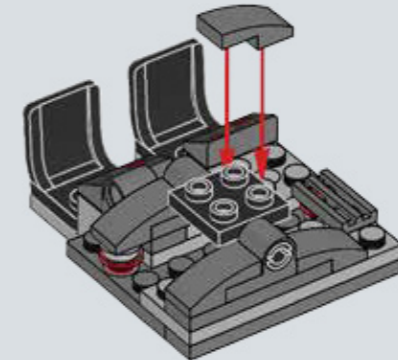

163

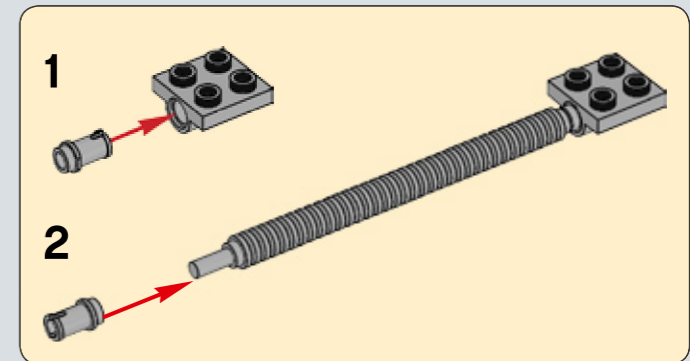
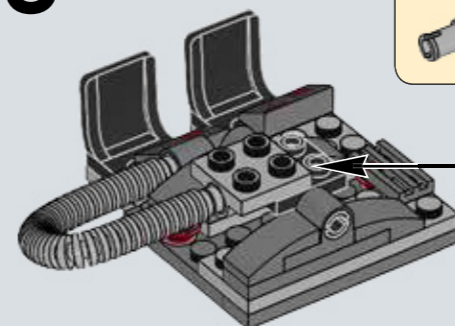

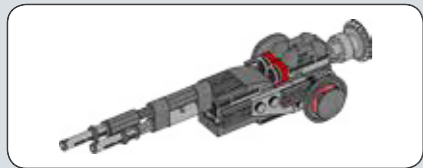

# 164



# 165

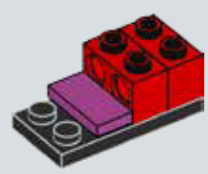

# 166

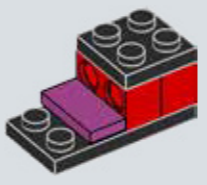

# 167

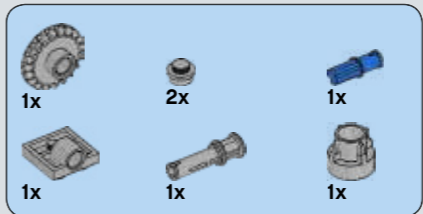
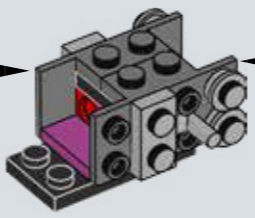
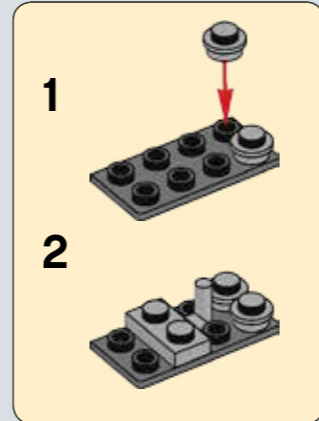
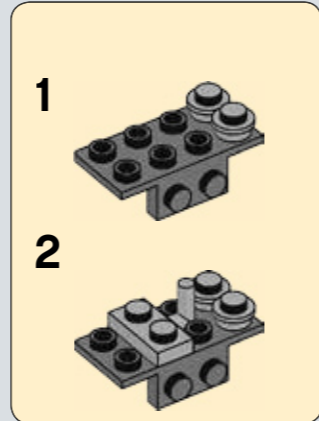

# 168

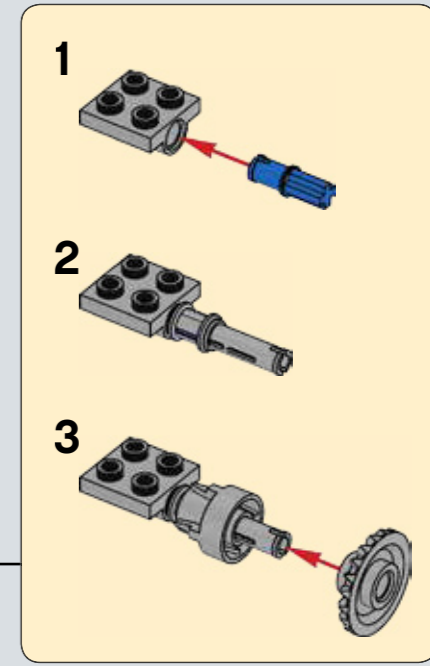
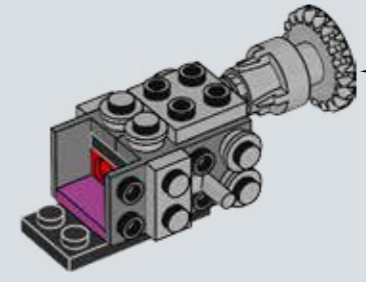

# 169

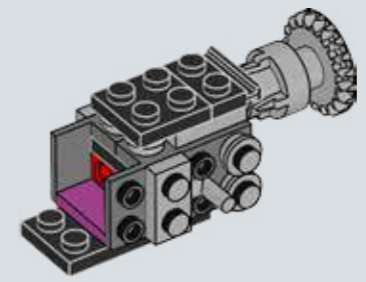



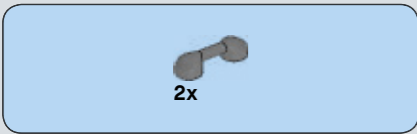

170

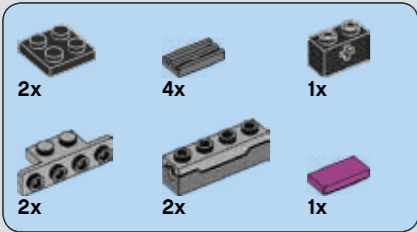
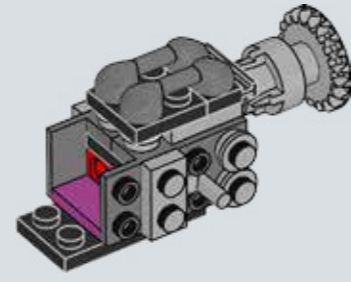

171

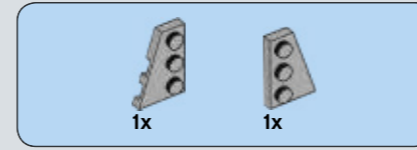
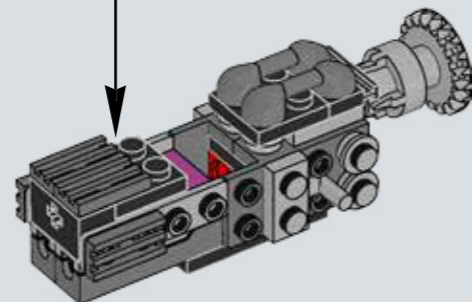
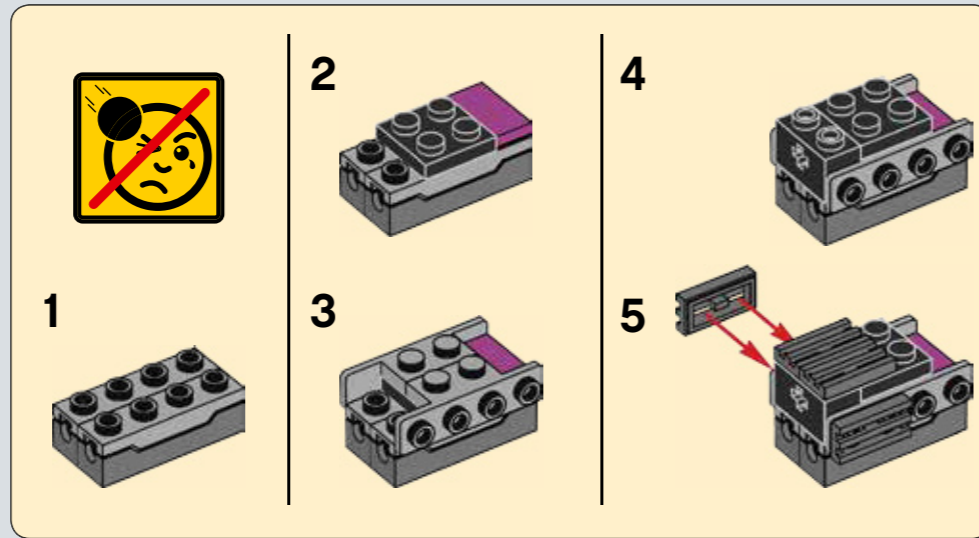

172

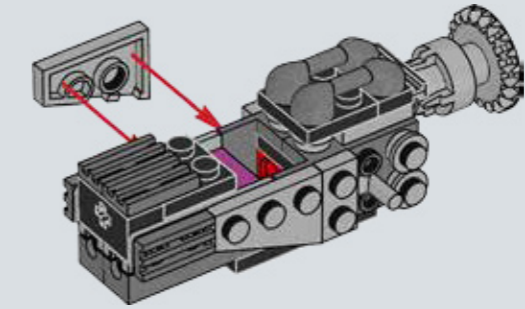

173

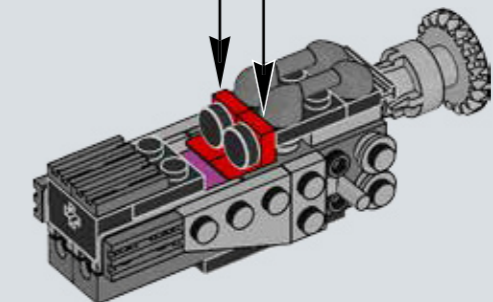
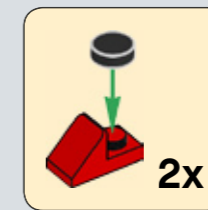



174

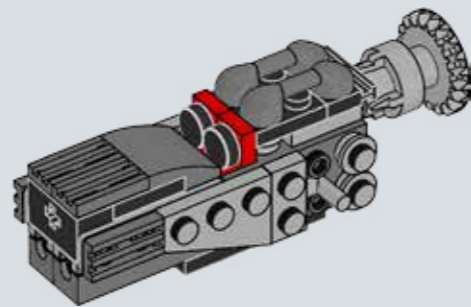

175

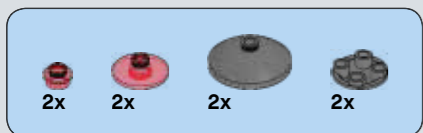
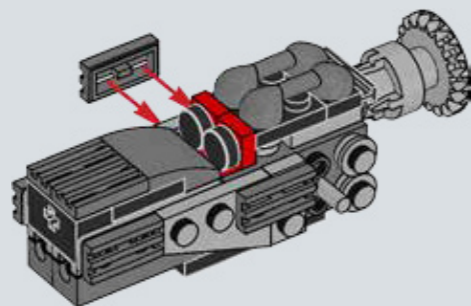

176

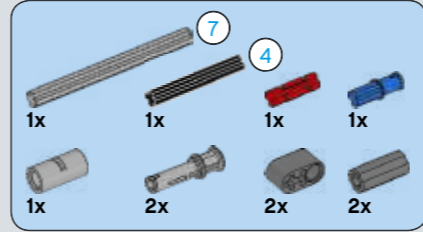
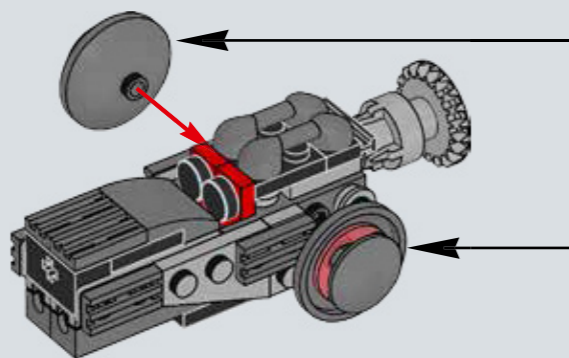

177

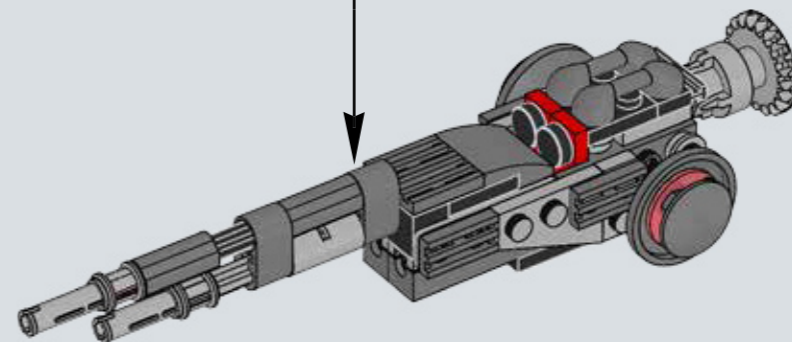
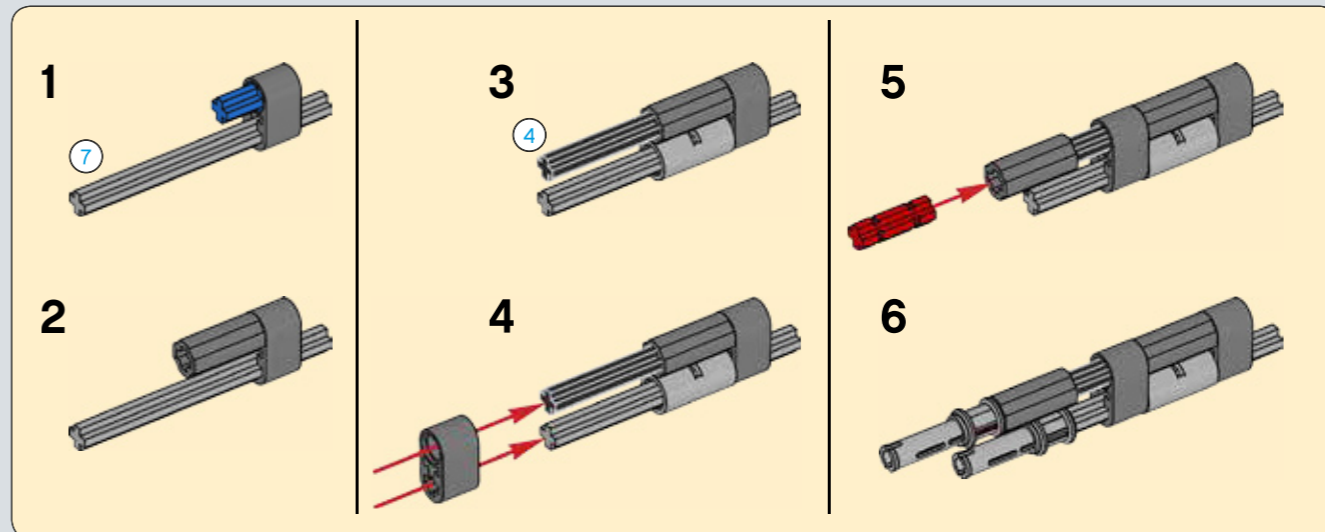
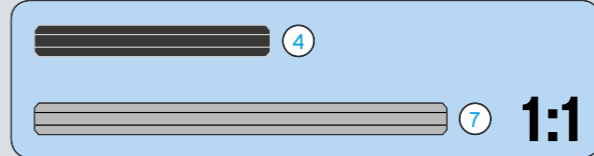

178

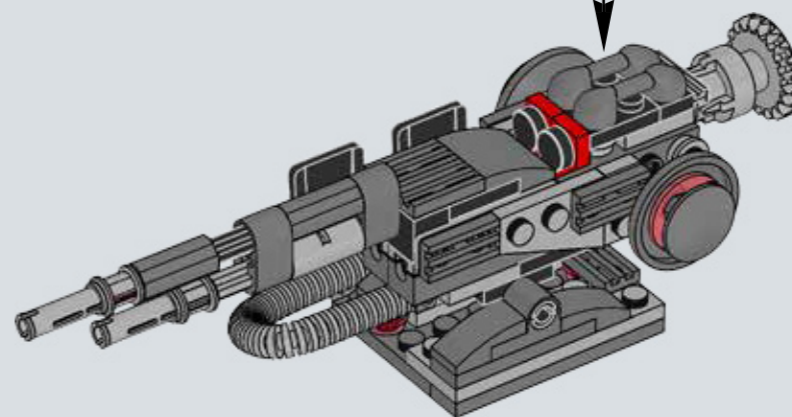

179

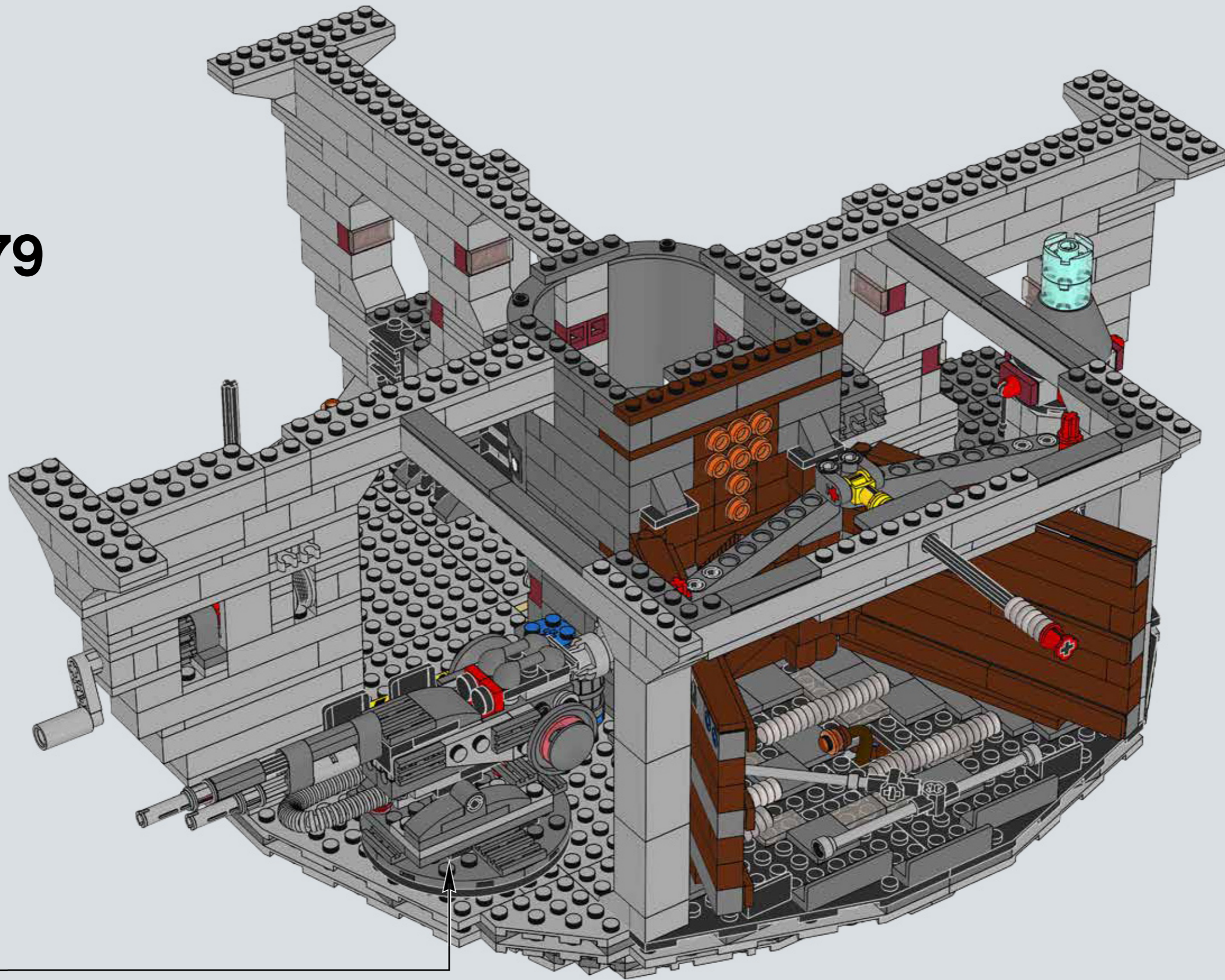

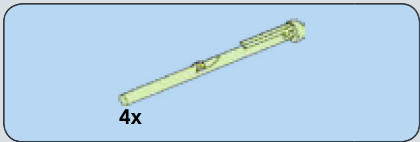

180

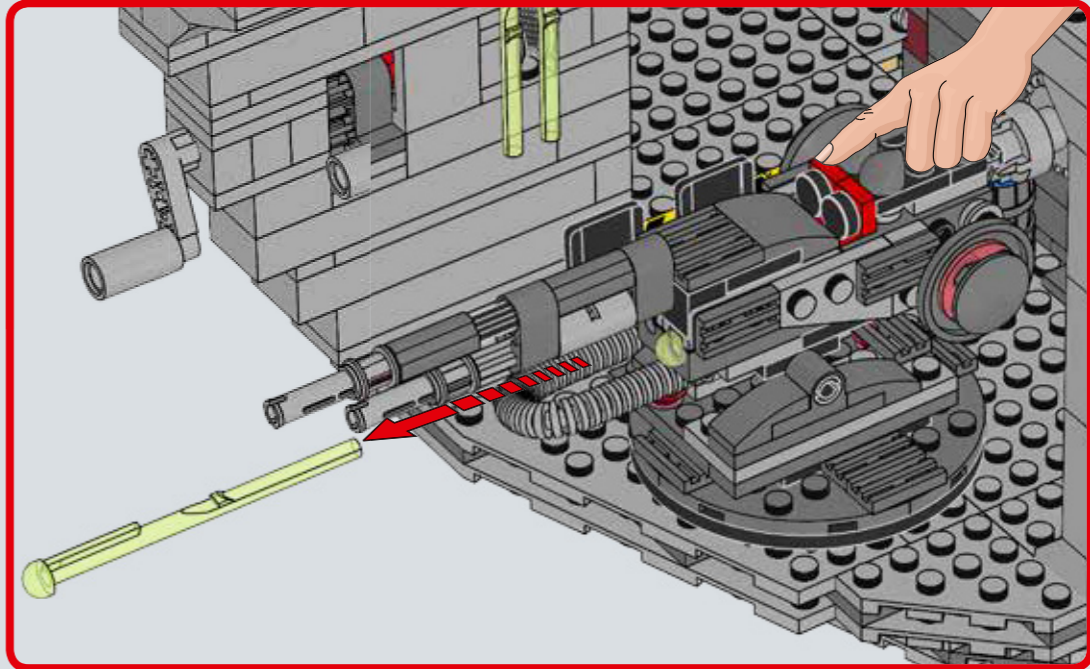
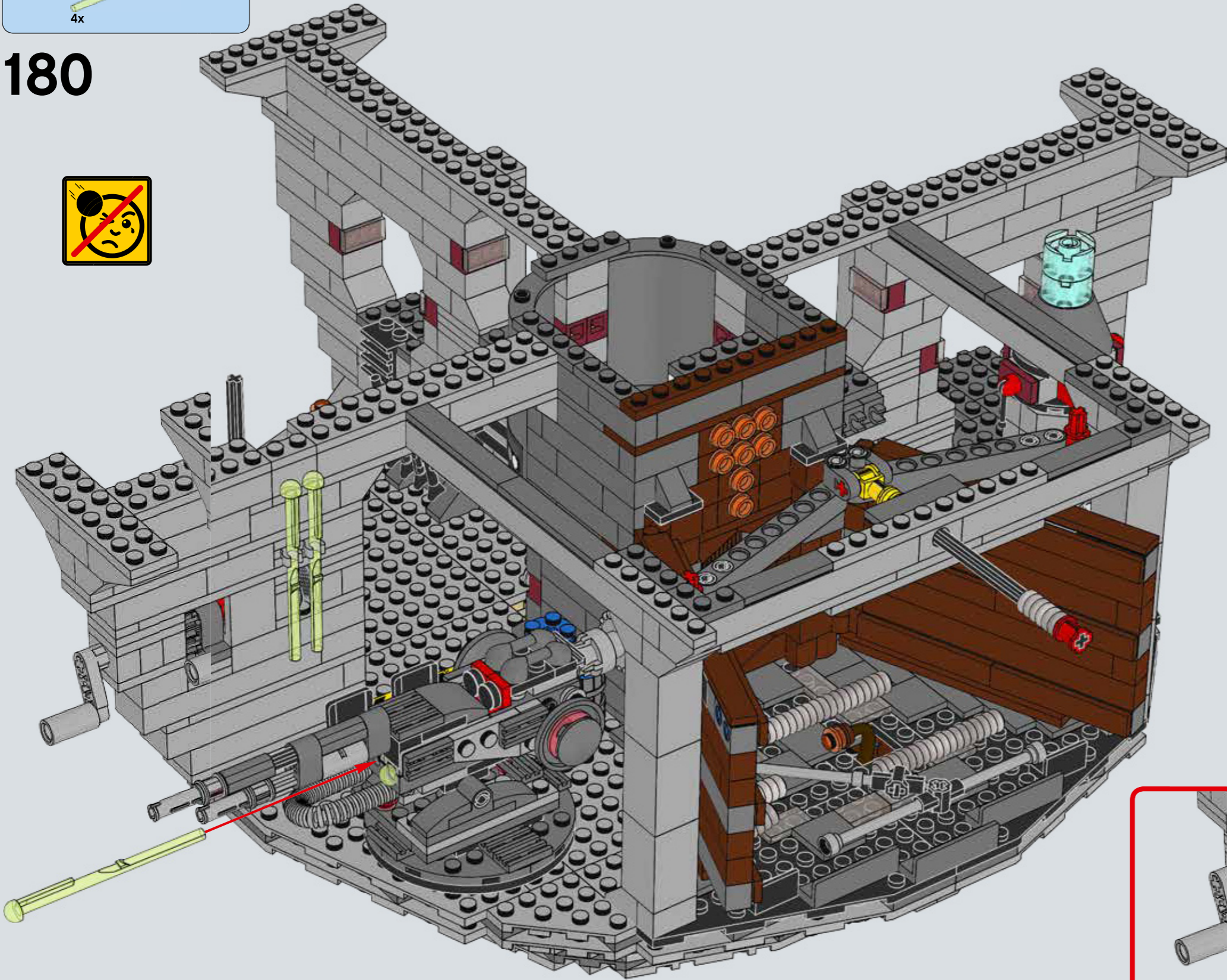

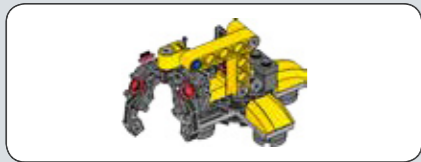

181



182



183

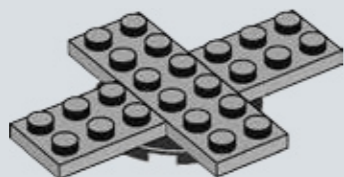

184

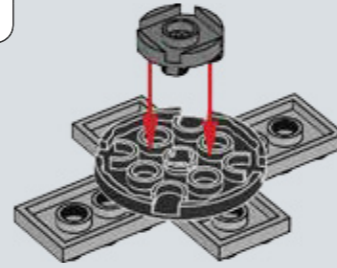

185

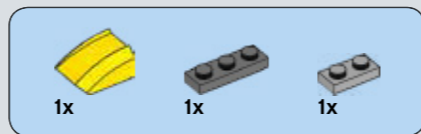
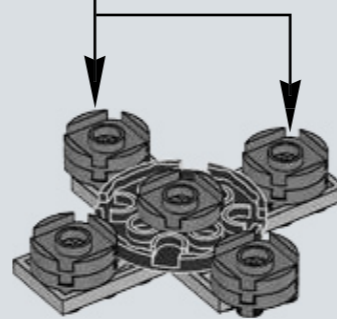
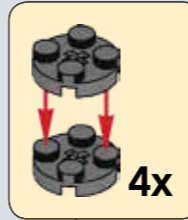

186

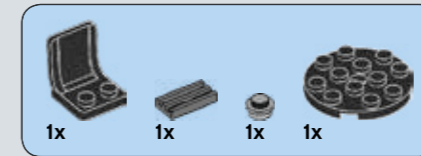
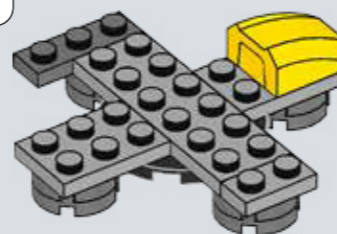

187

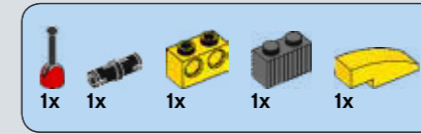
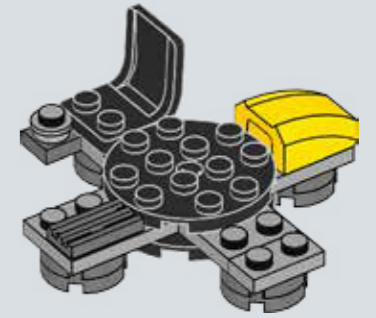

188

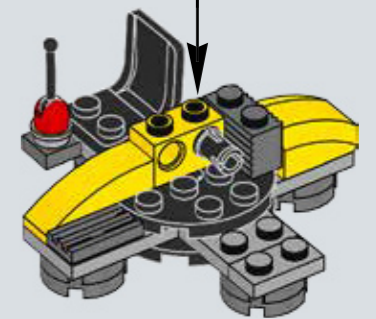
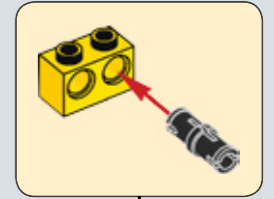

189

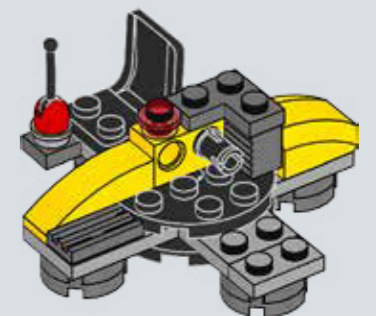

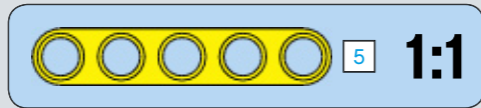
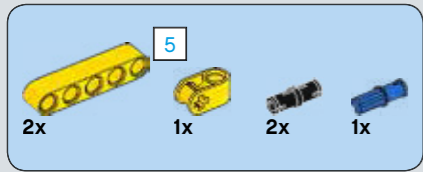

# 190

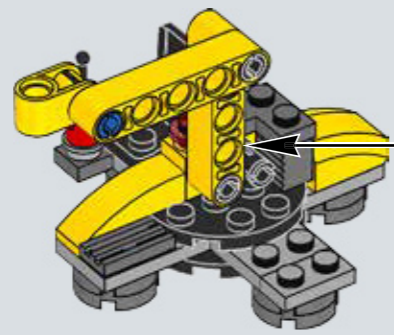
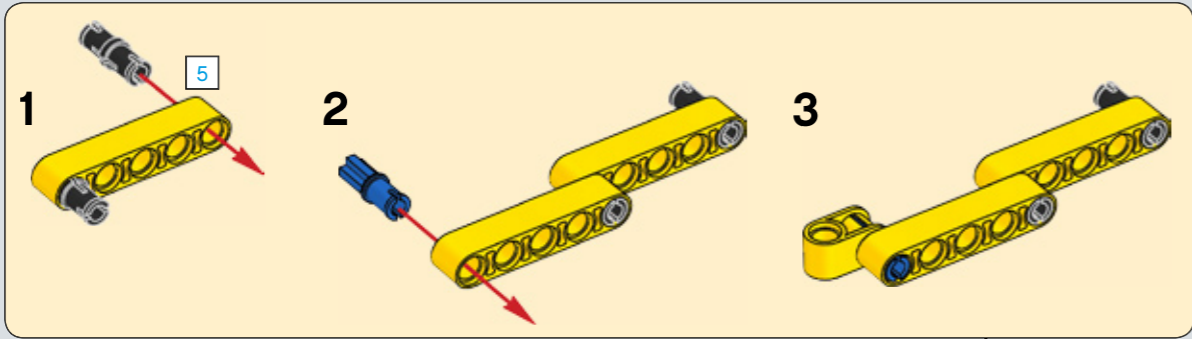

# 191

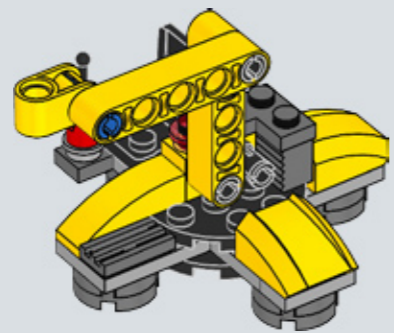

# 192

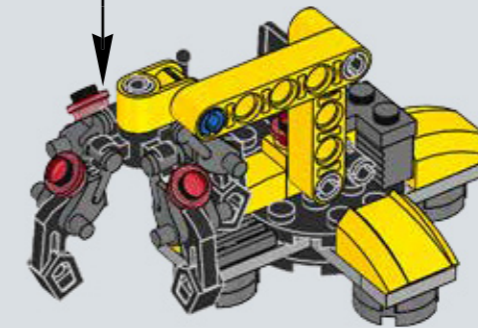
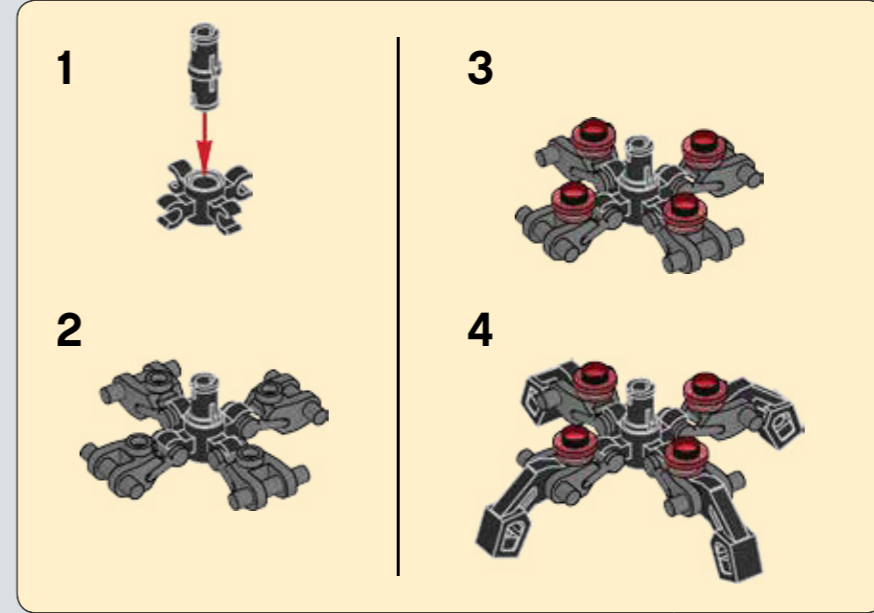

193

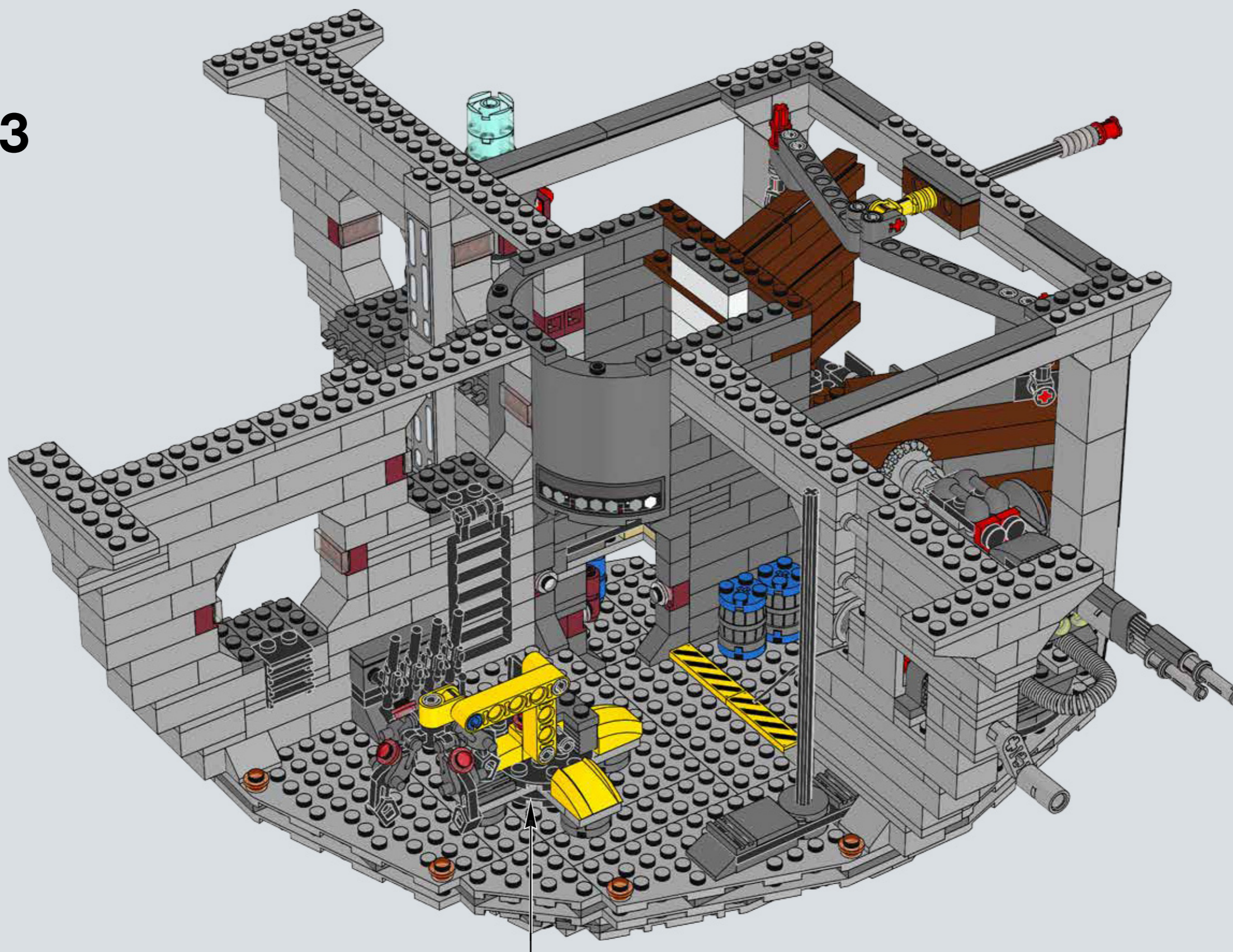
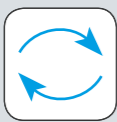



194

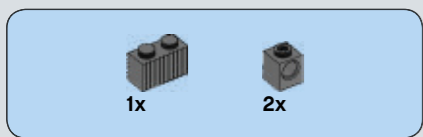
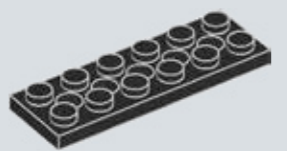

195

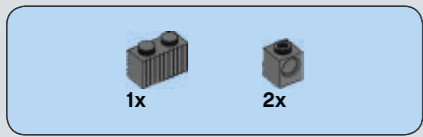
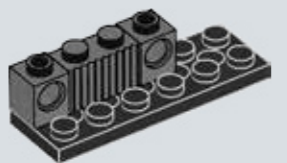

196

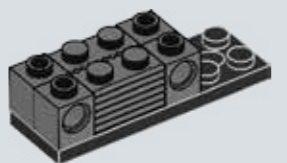

197

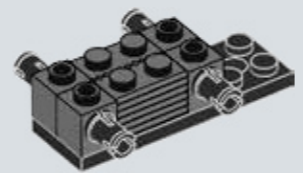

198

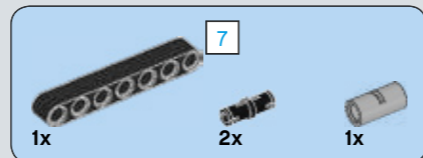
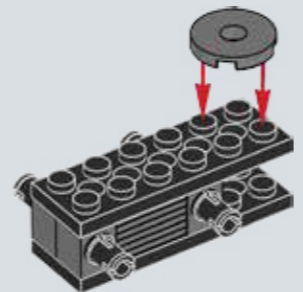

199

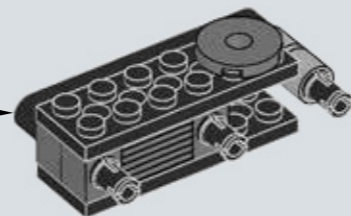
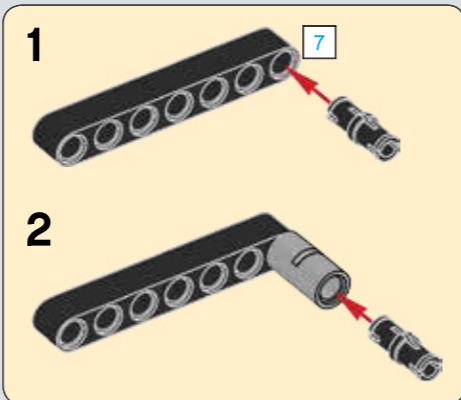

200

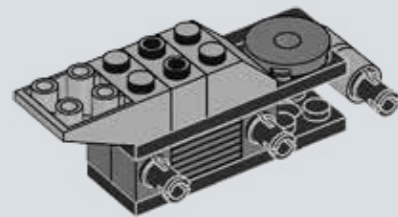

201

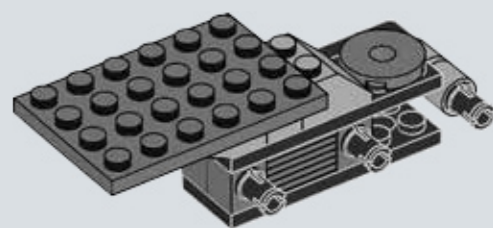

202

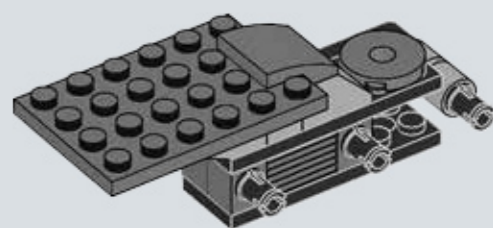



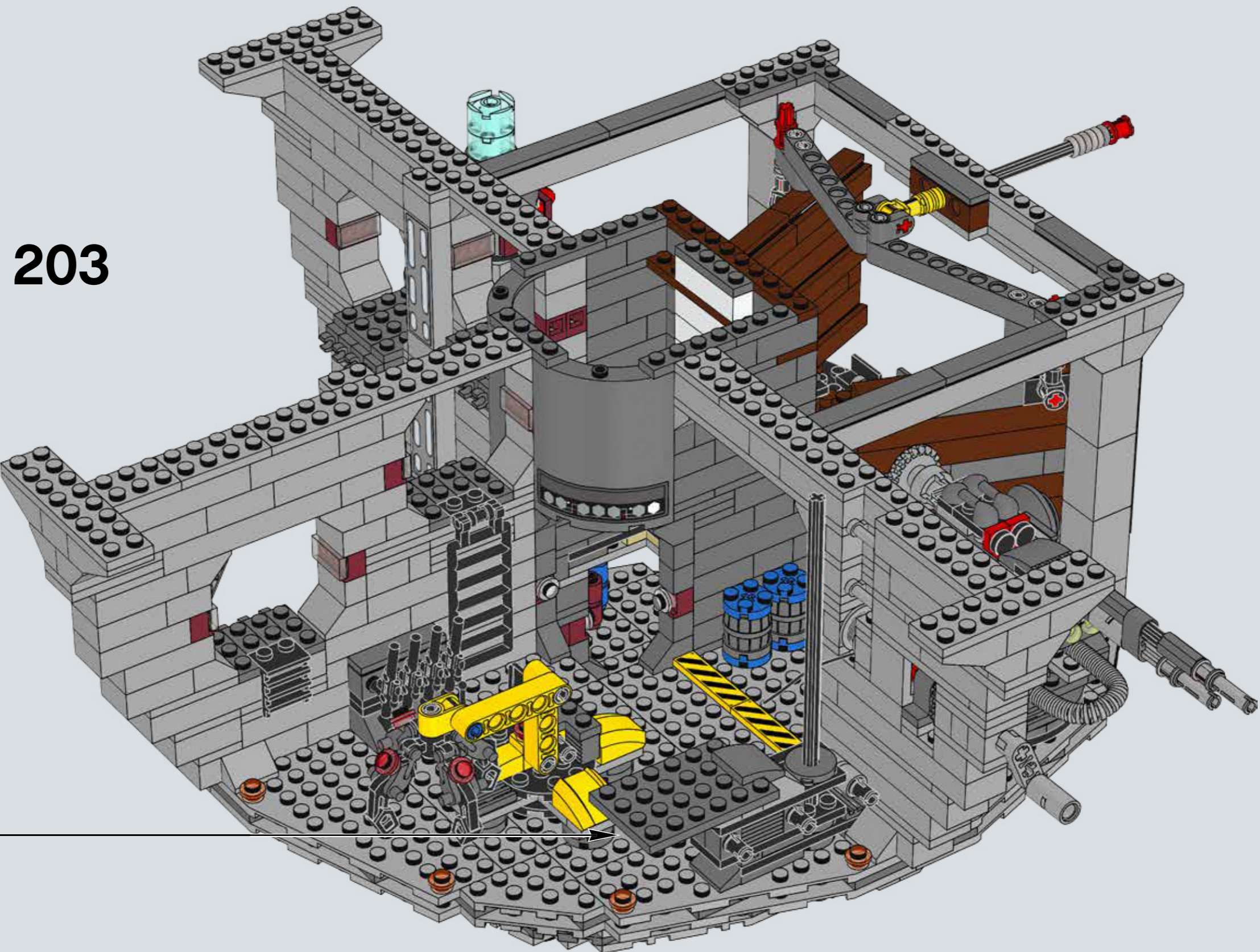

203

204

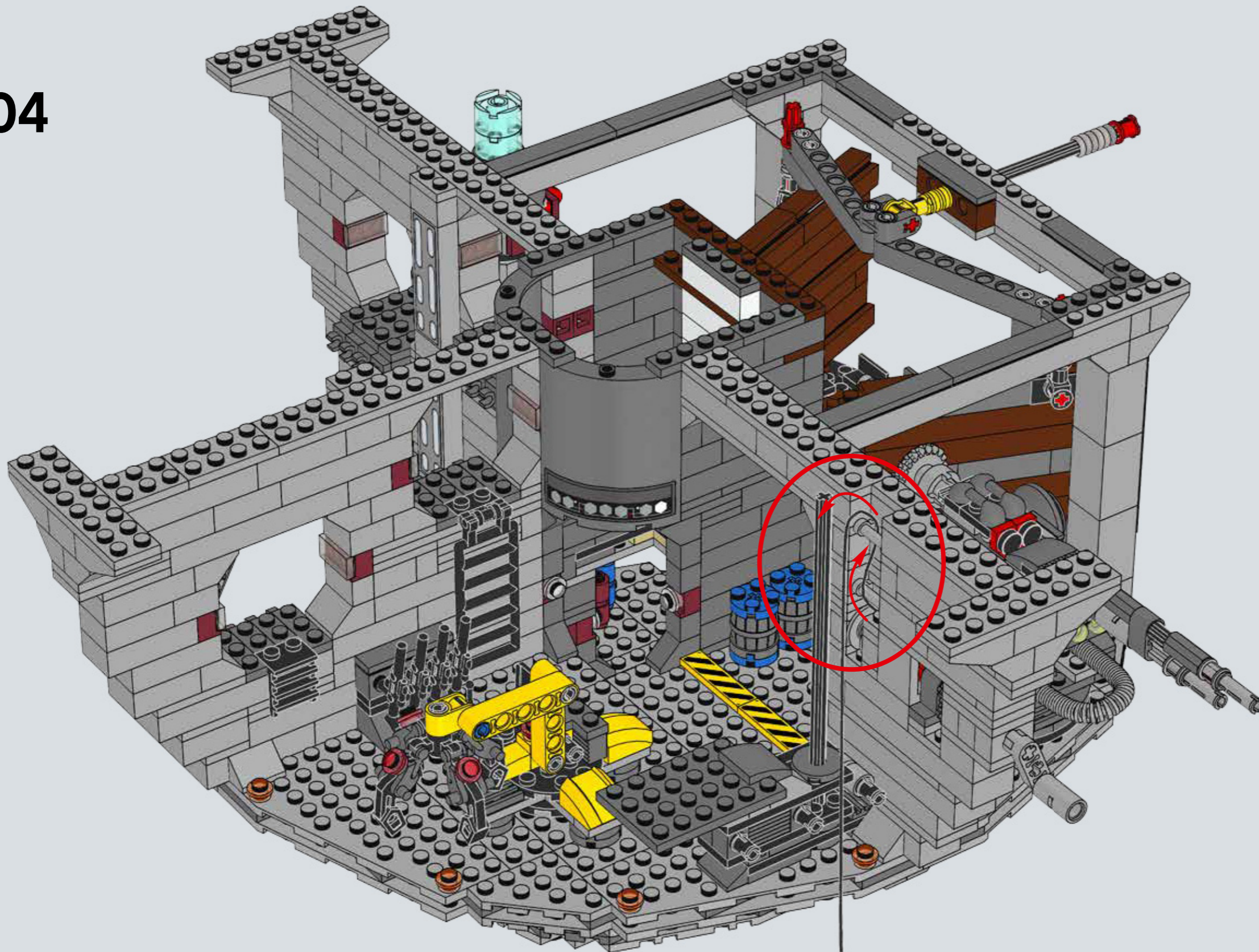

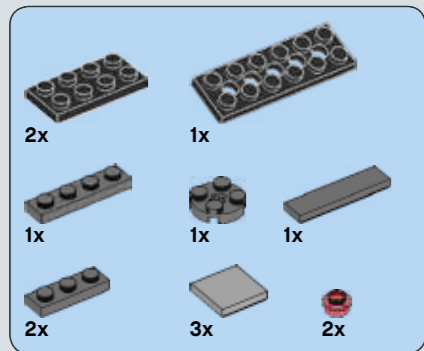

205

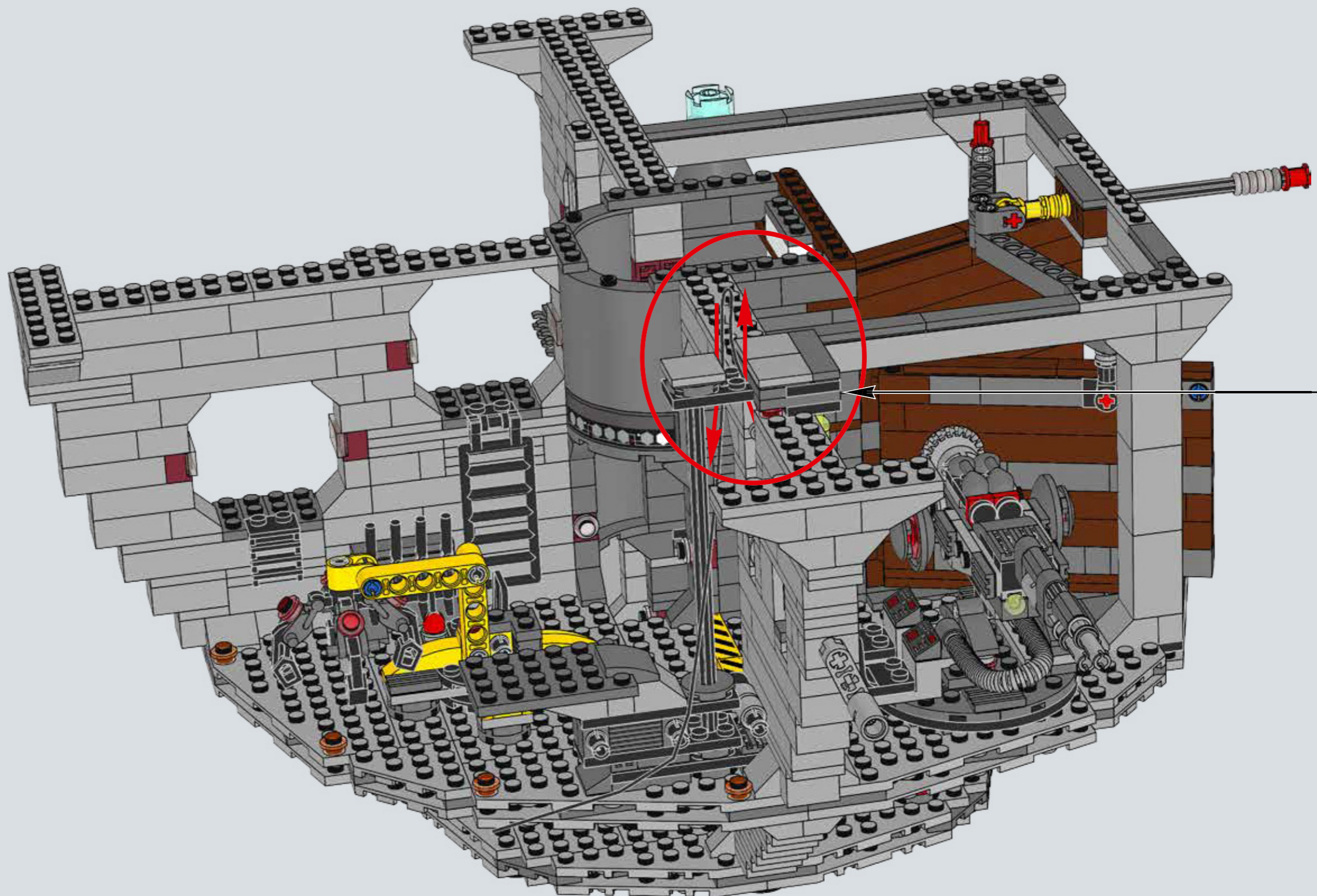
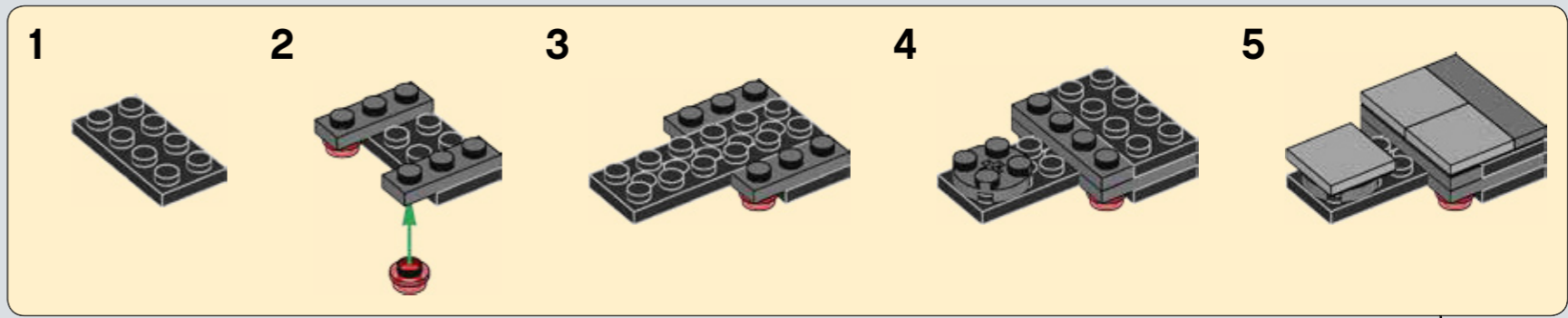

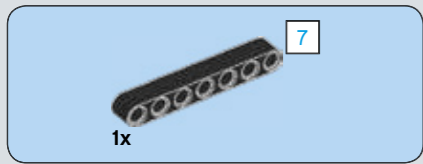

206

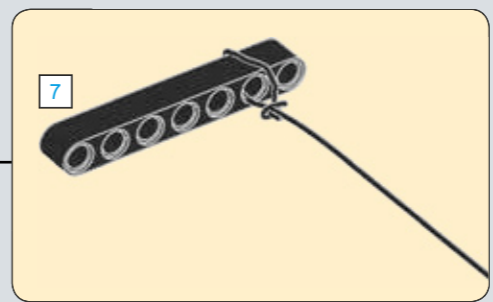
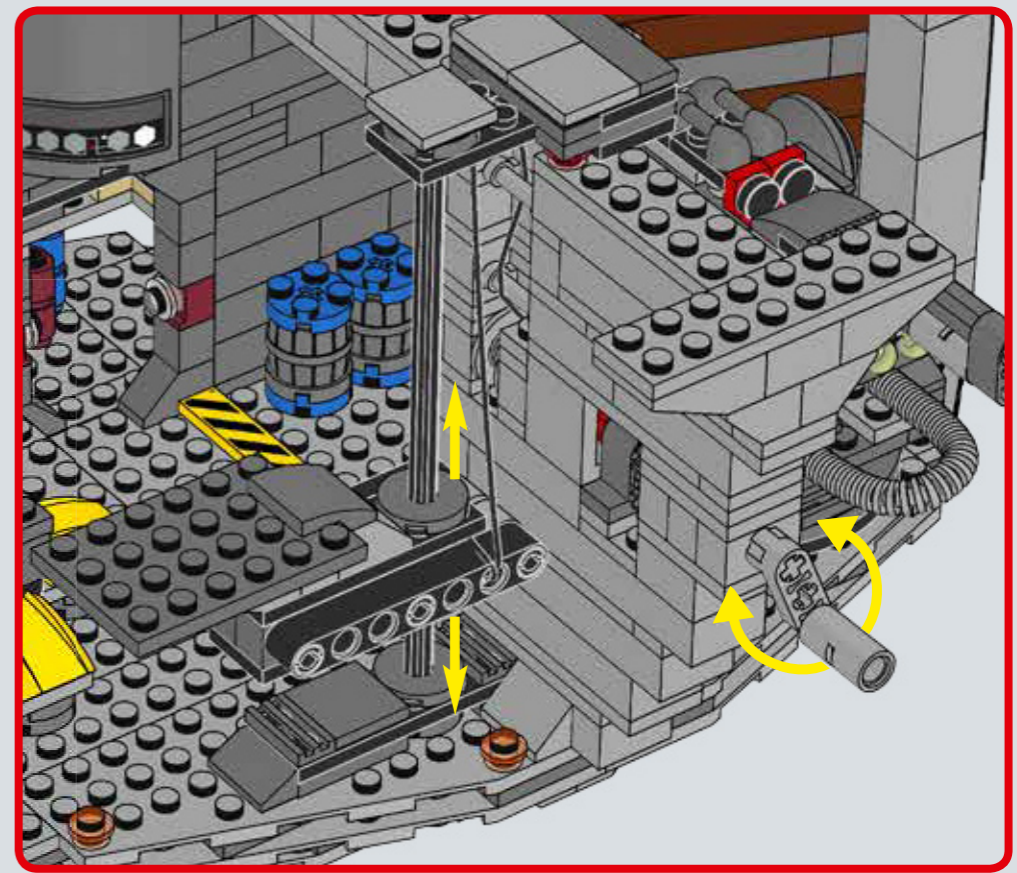
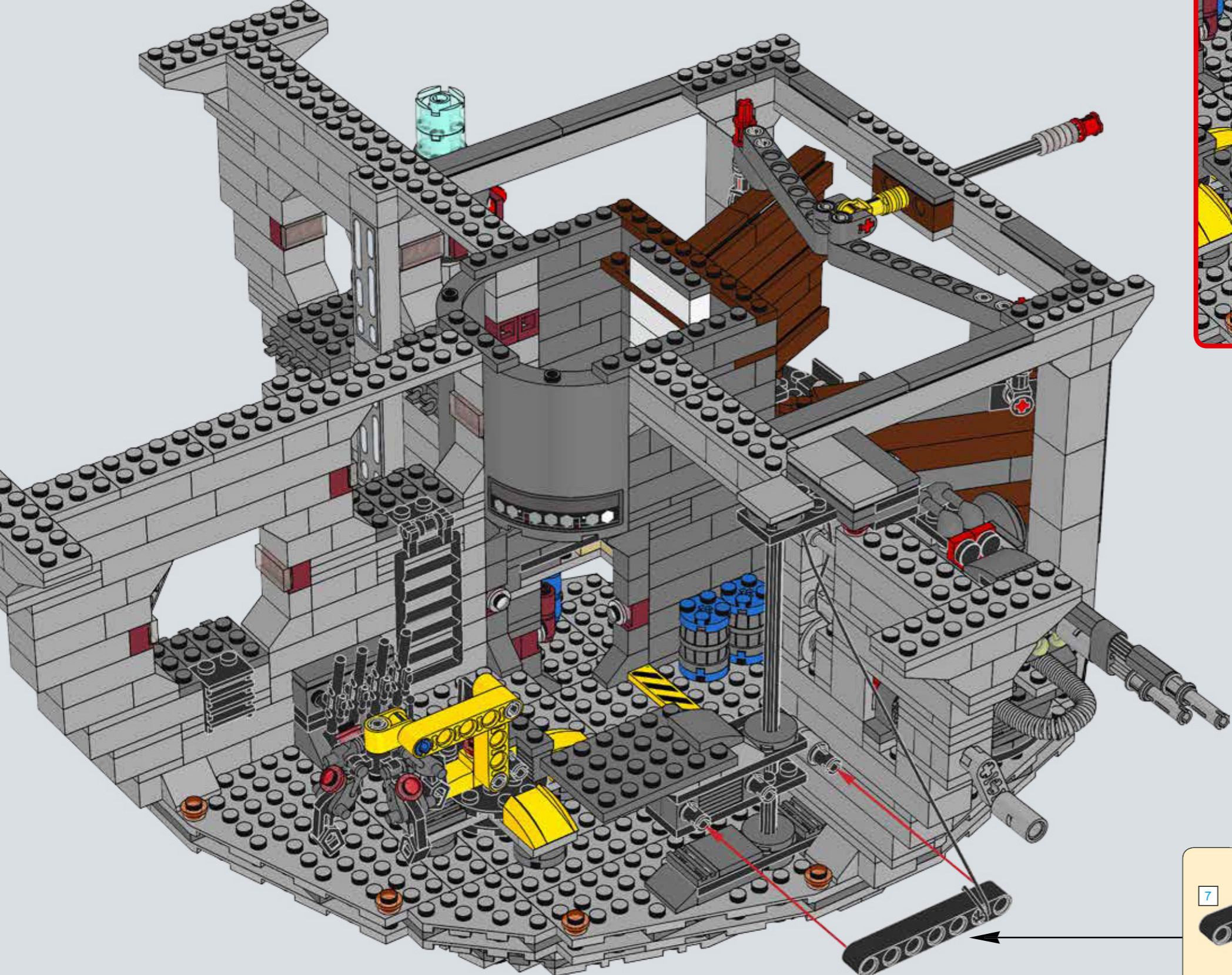

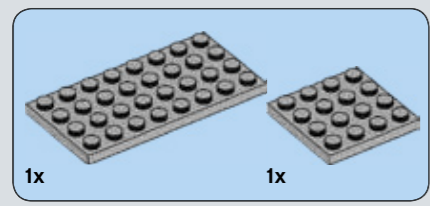
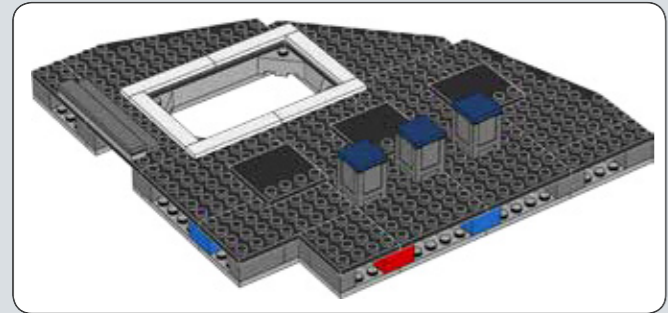
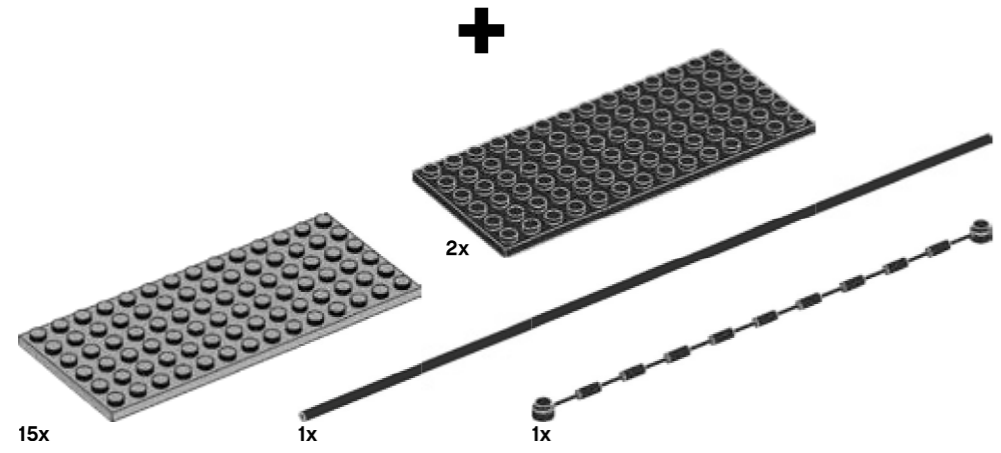
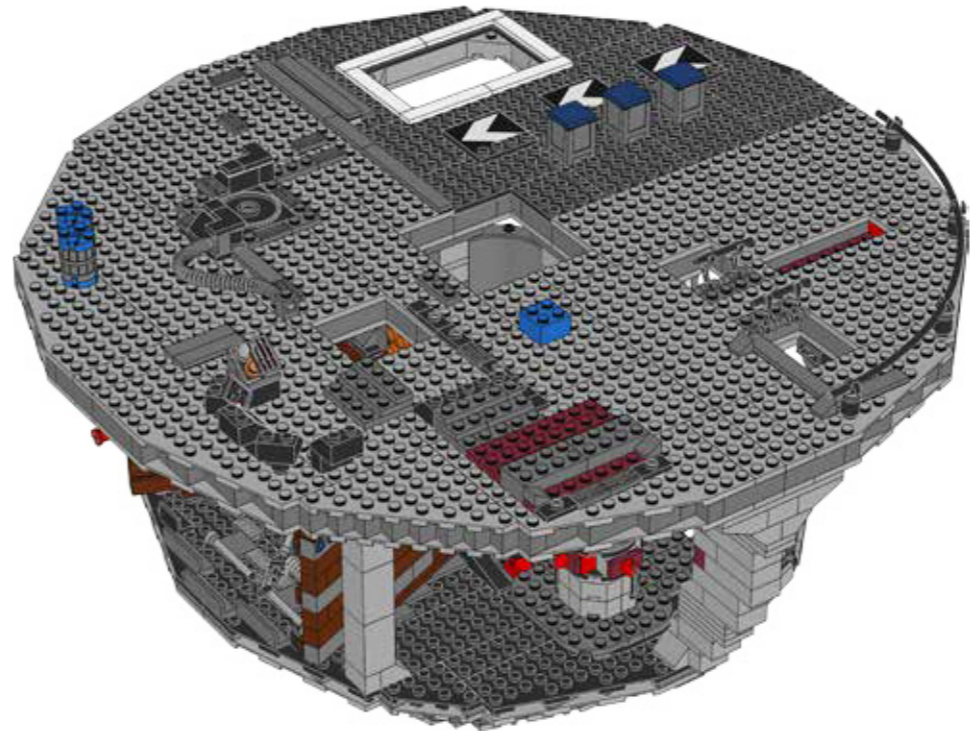

207

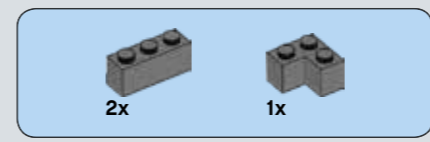
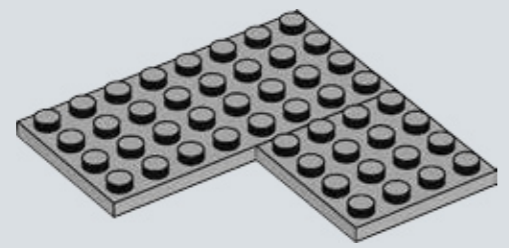

208

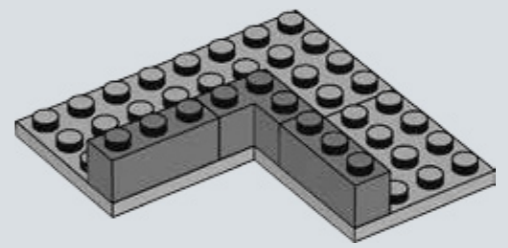

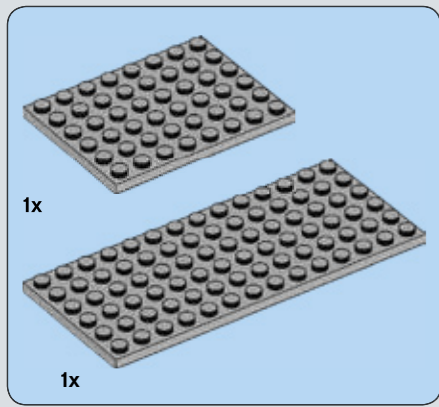

# 209

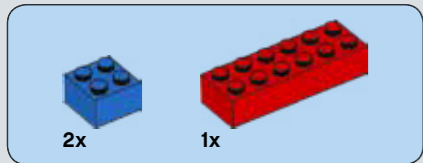
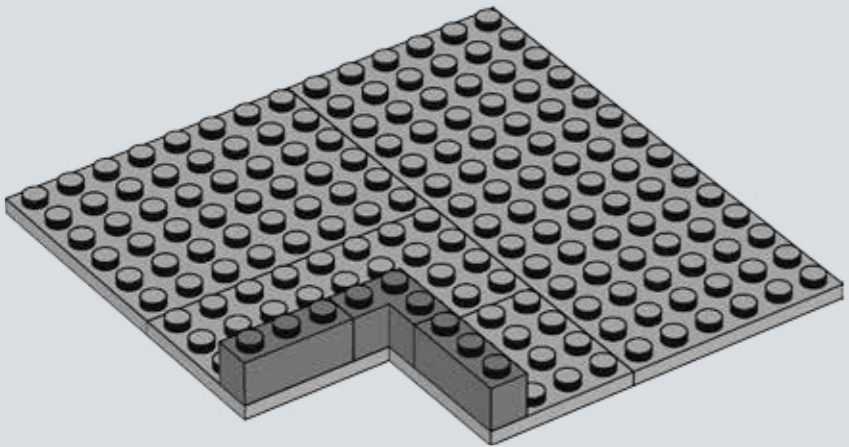

# 210

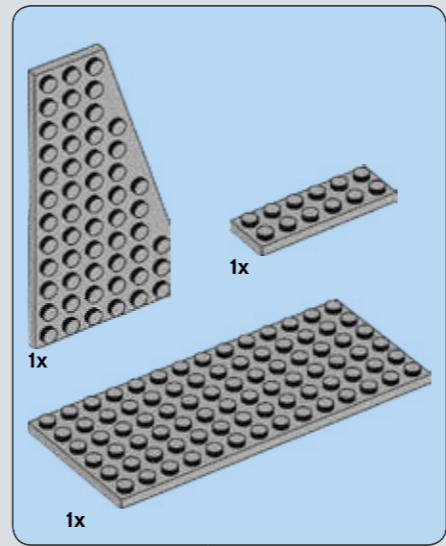
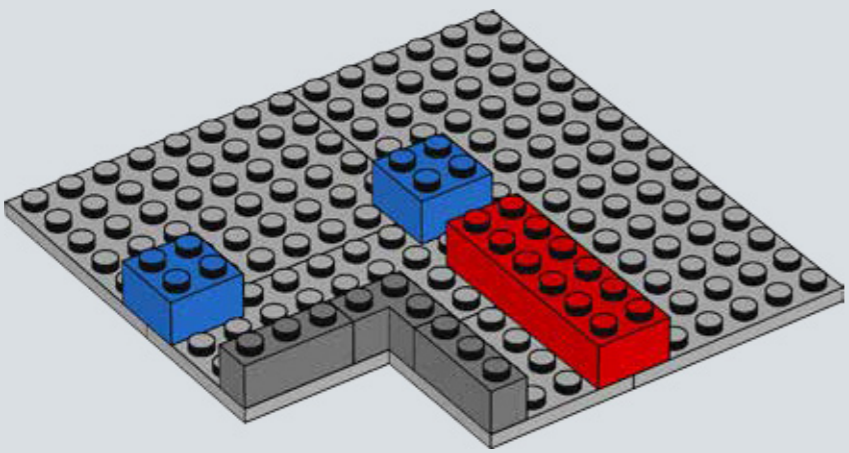

# 211

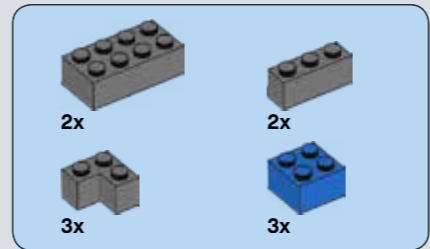
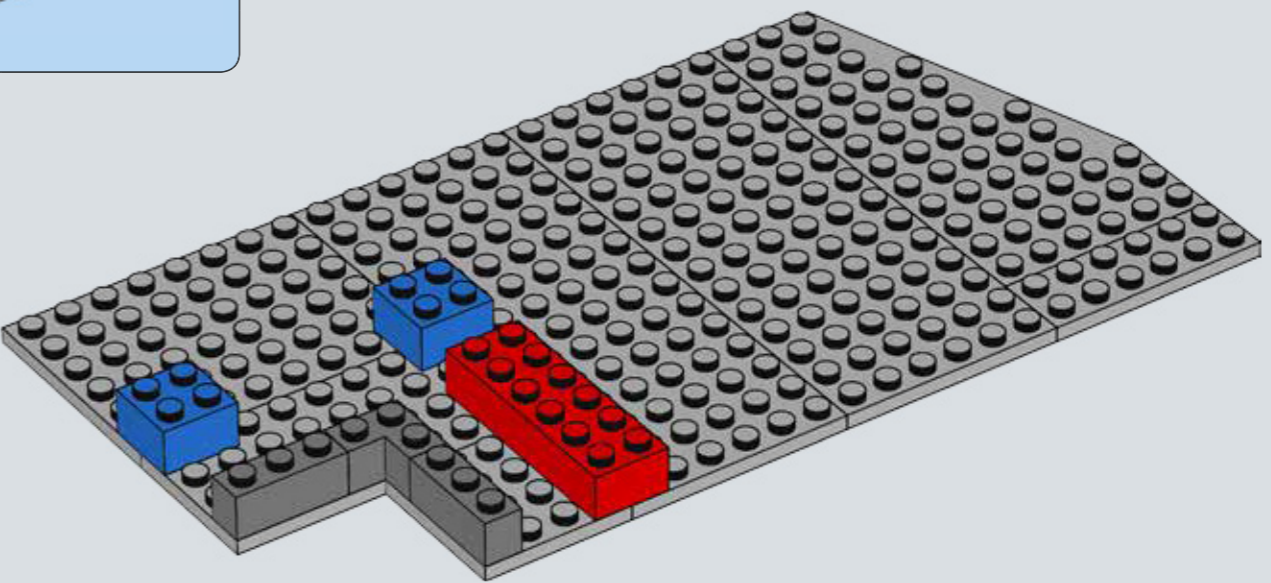

# 212

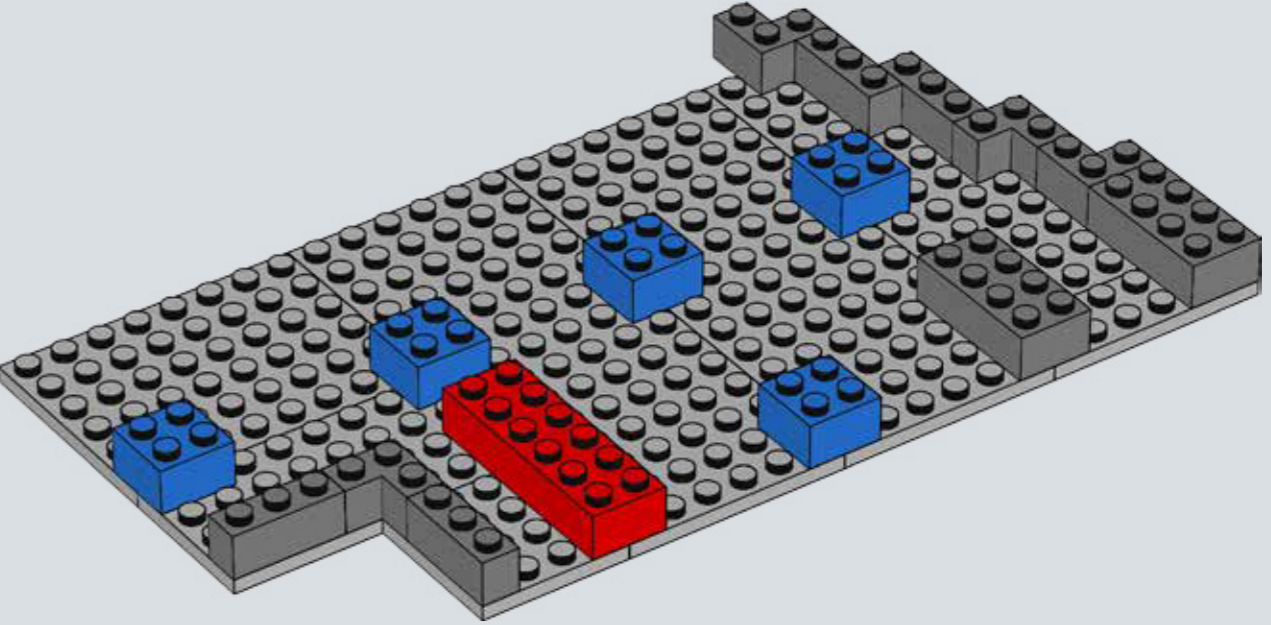

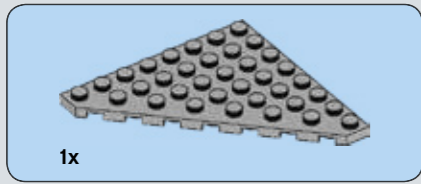

213

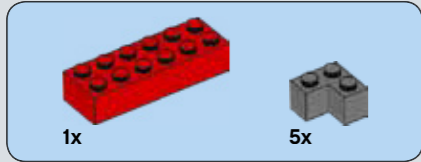
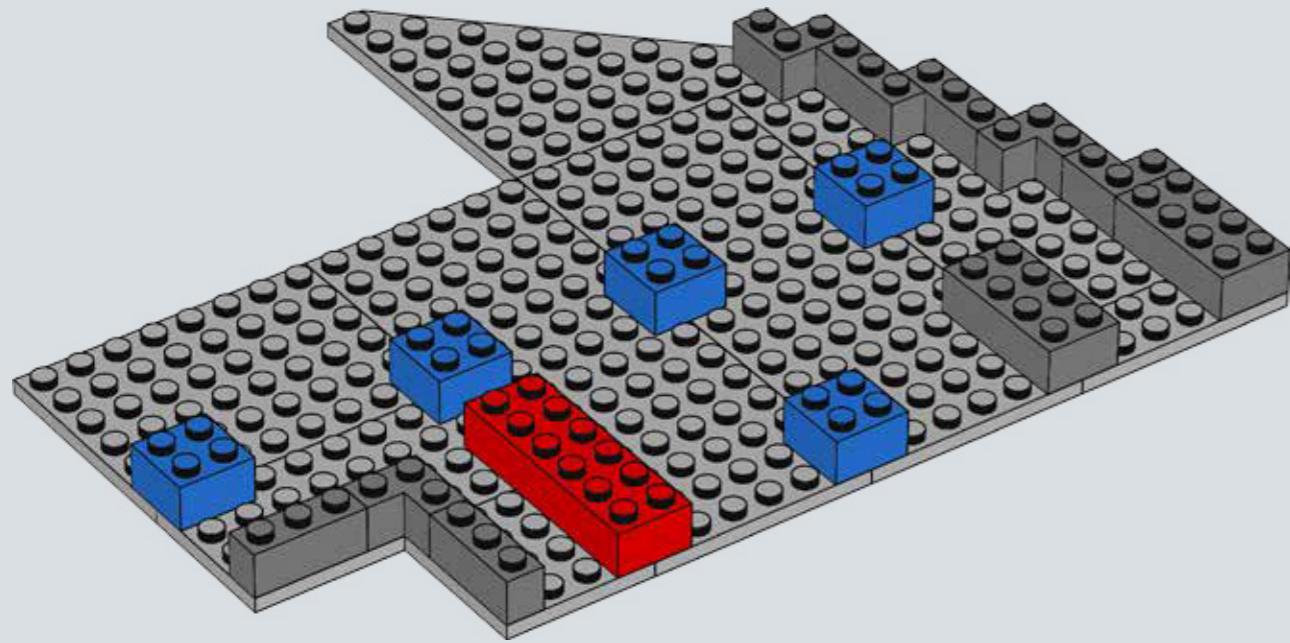

214

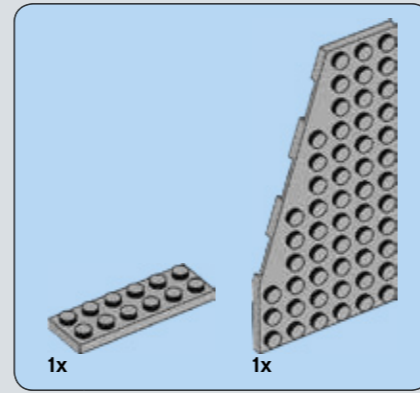
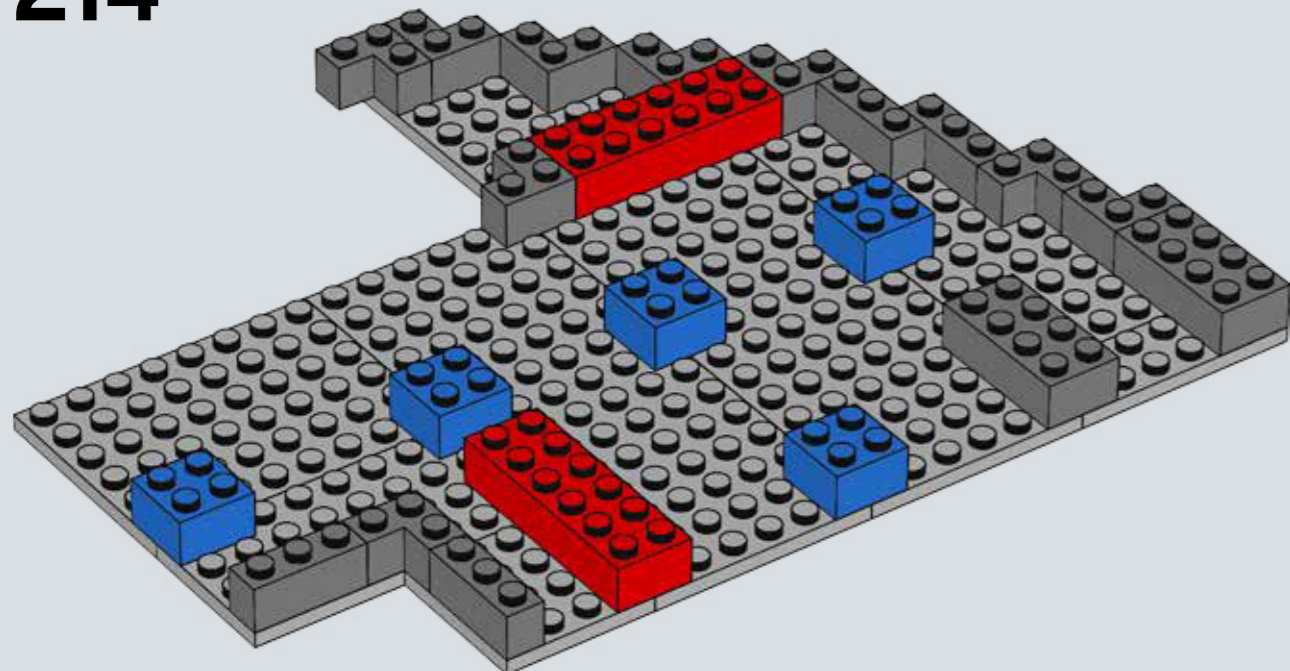

215

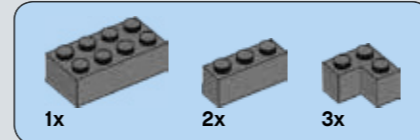
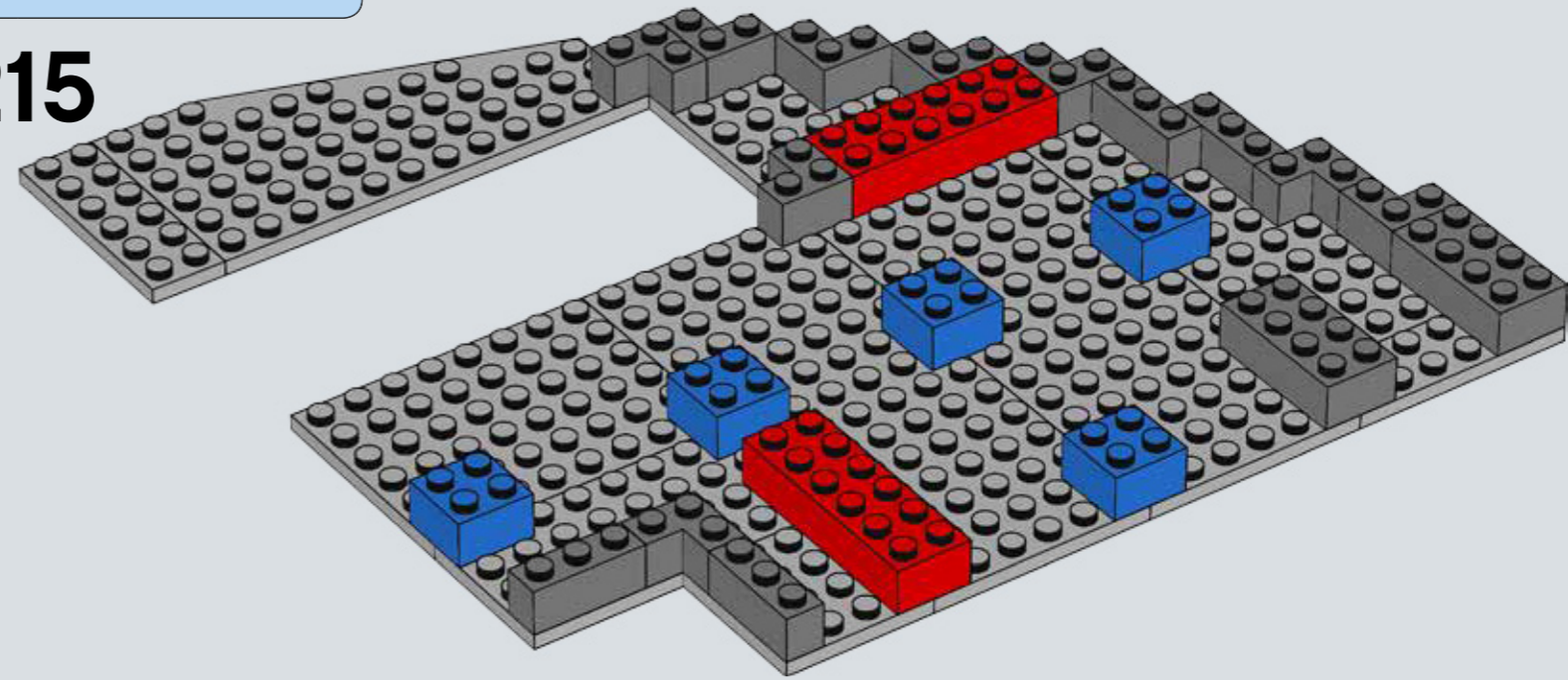

216

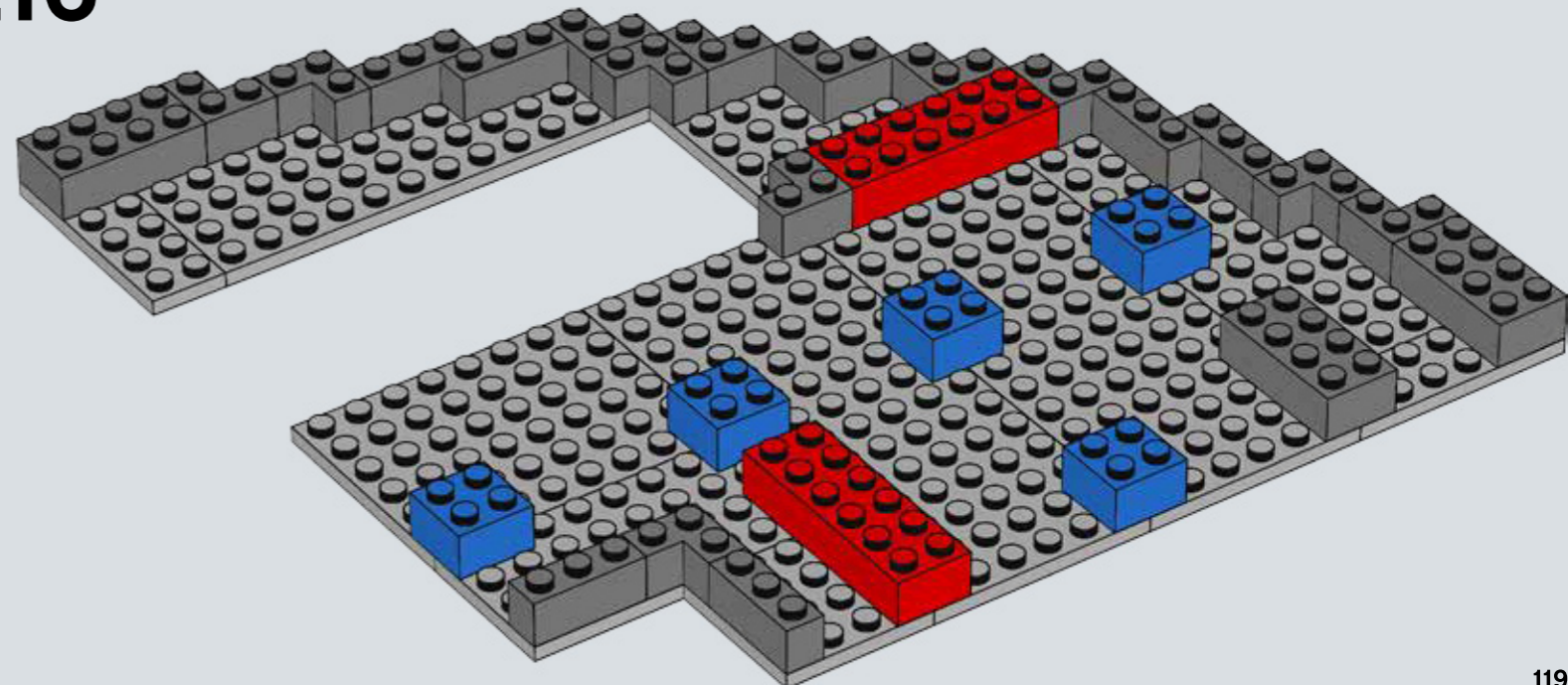

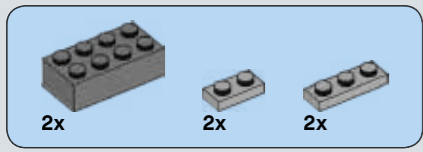

# 217

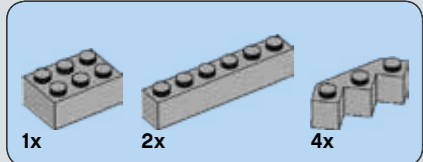
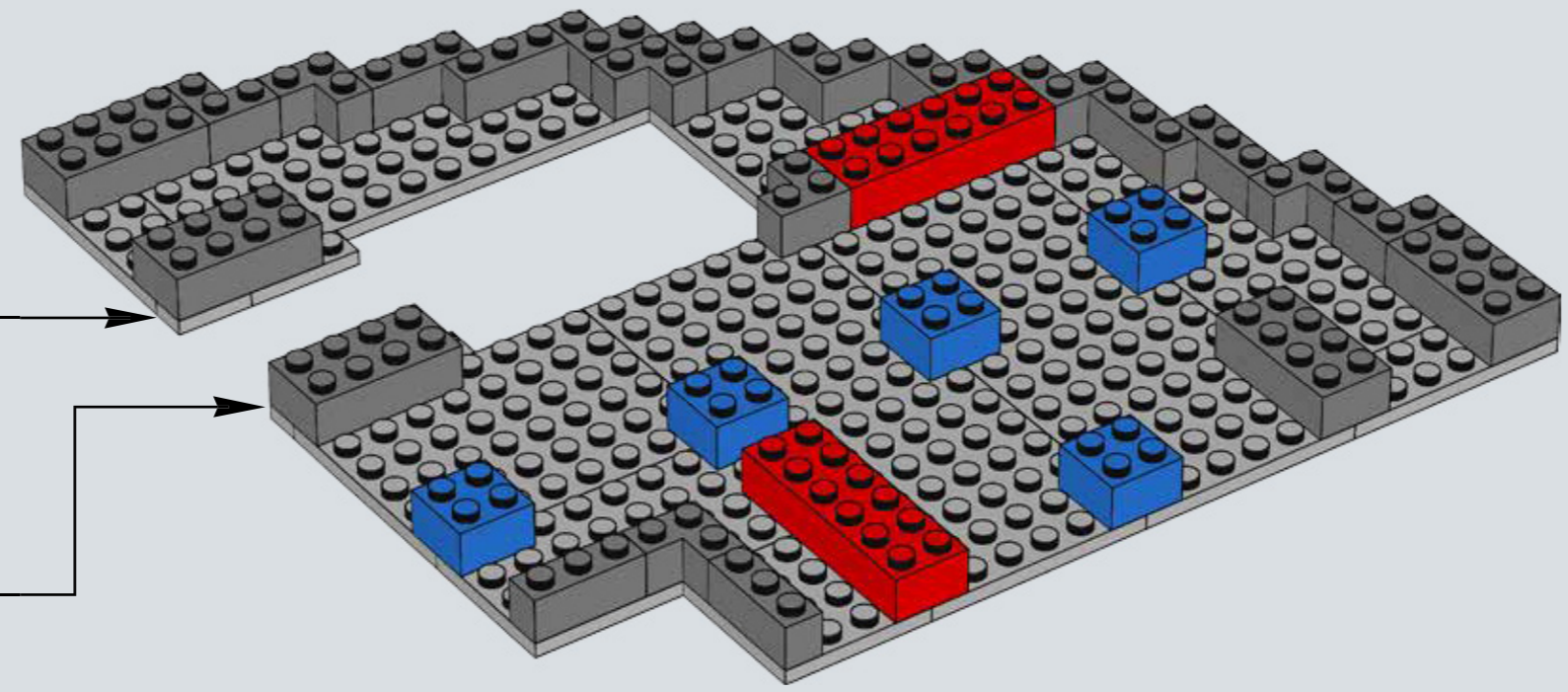
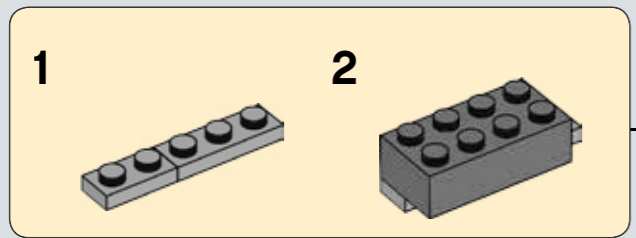
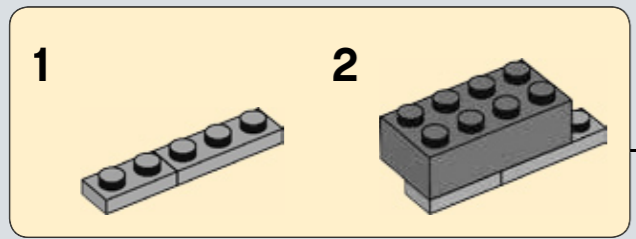

# 218

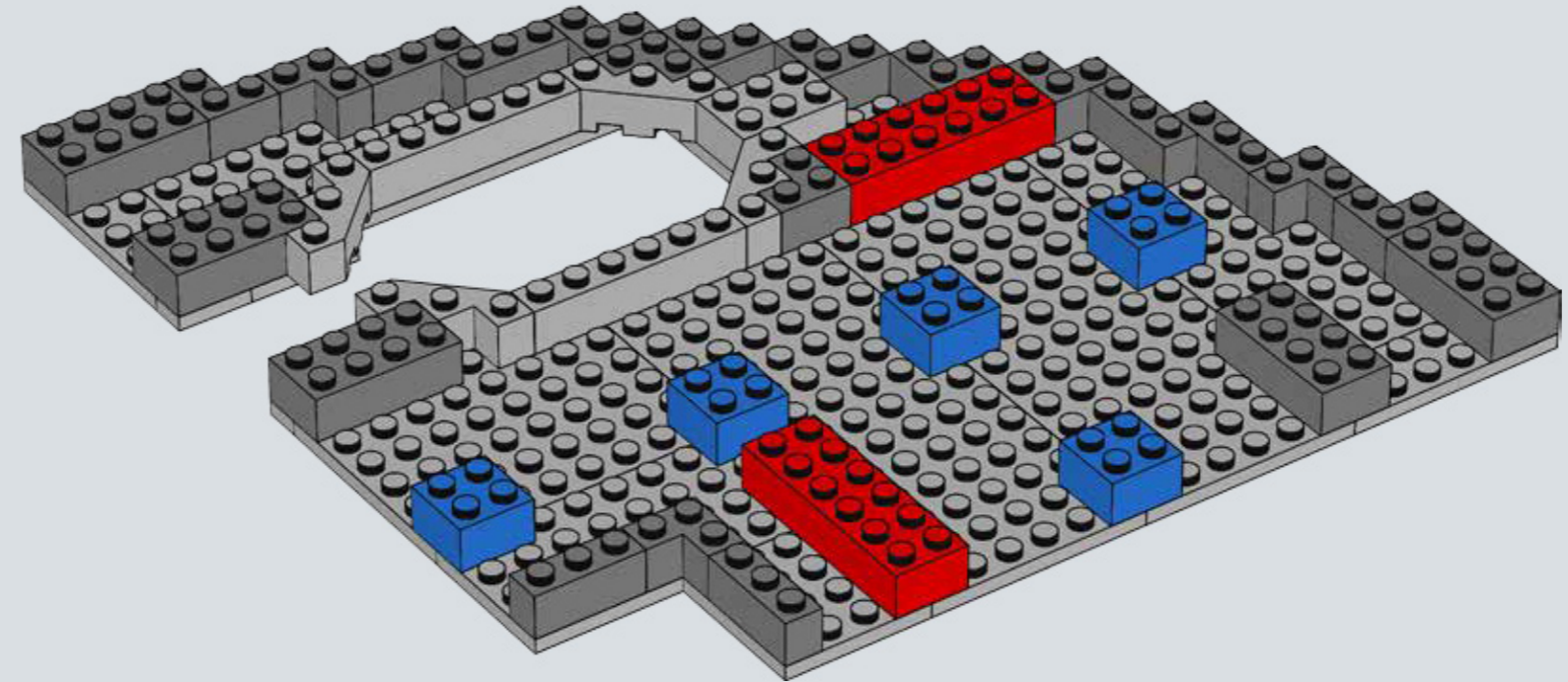



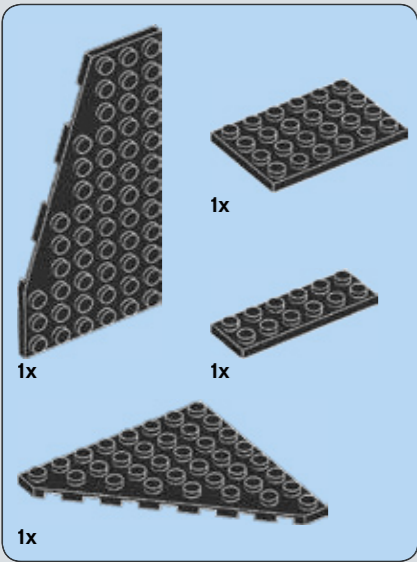

219

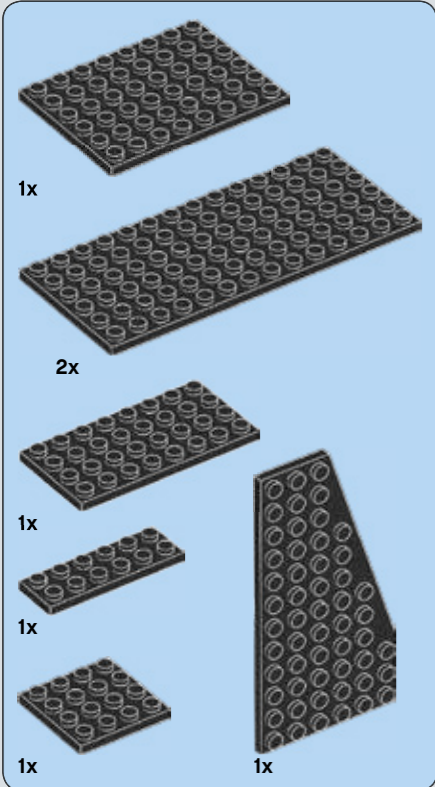
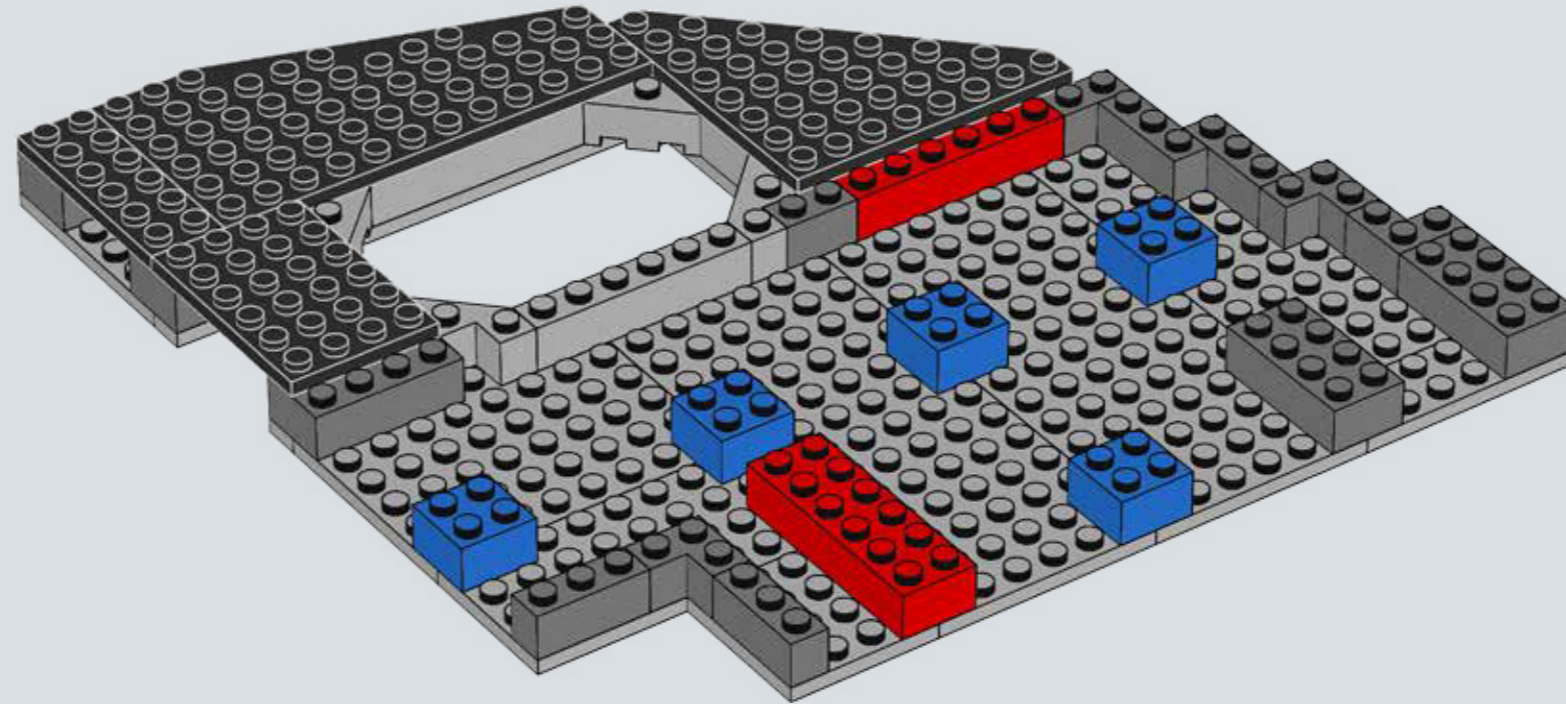

220

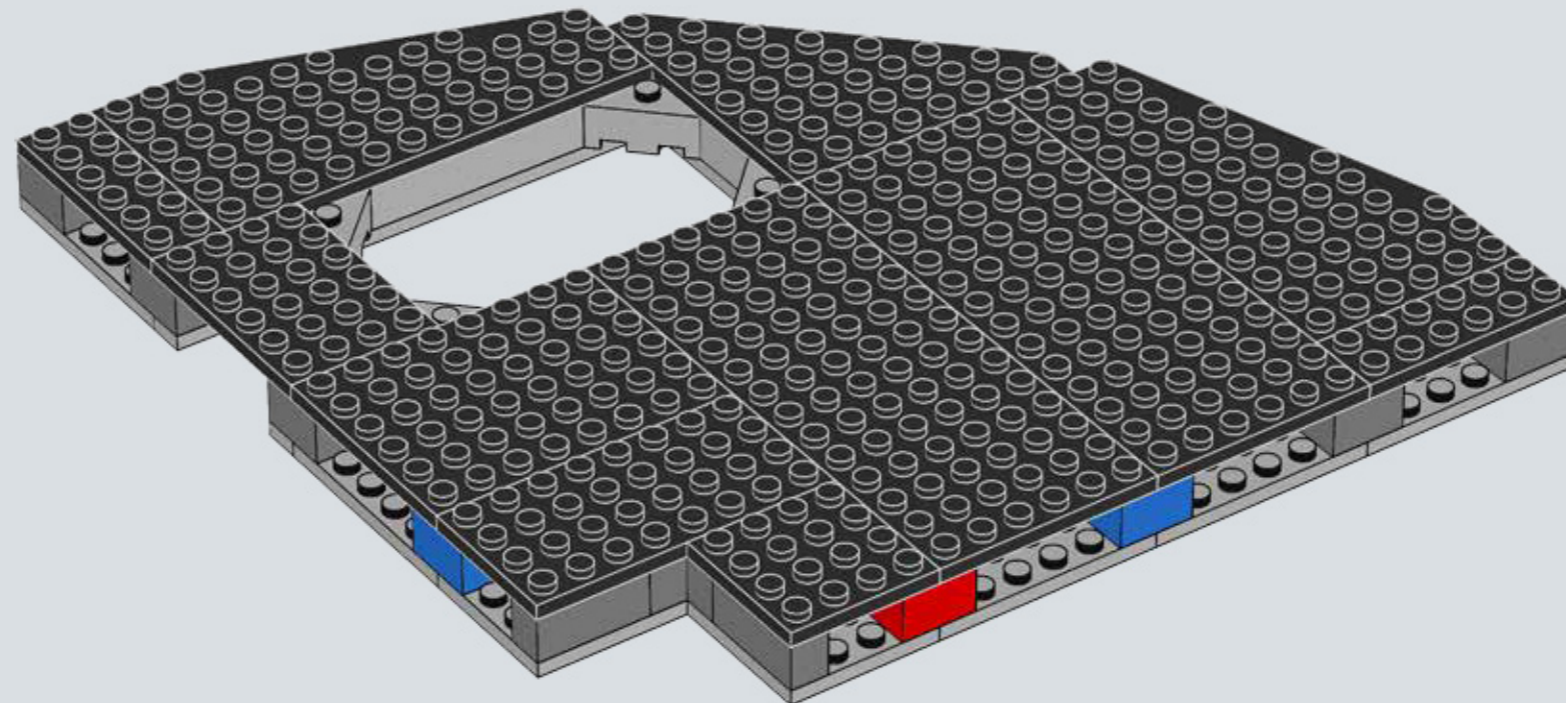

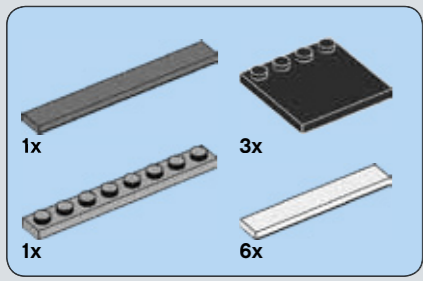

221

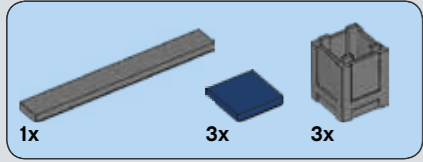
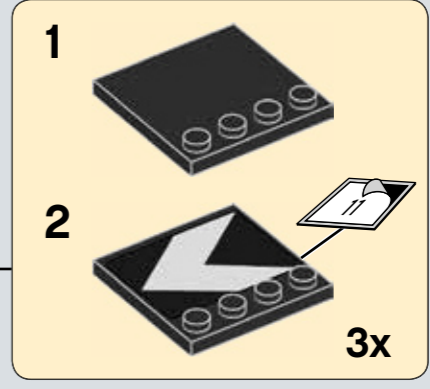
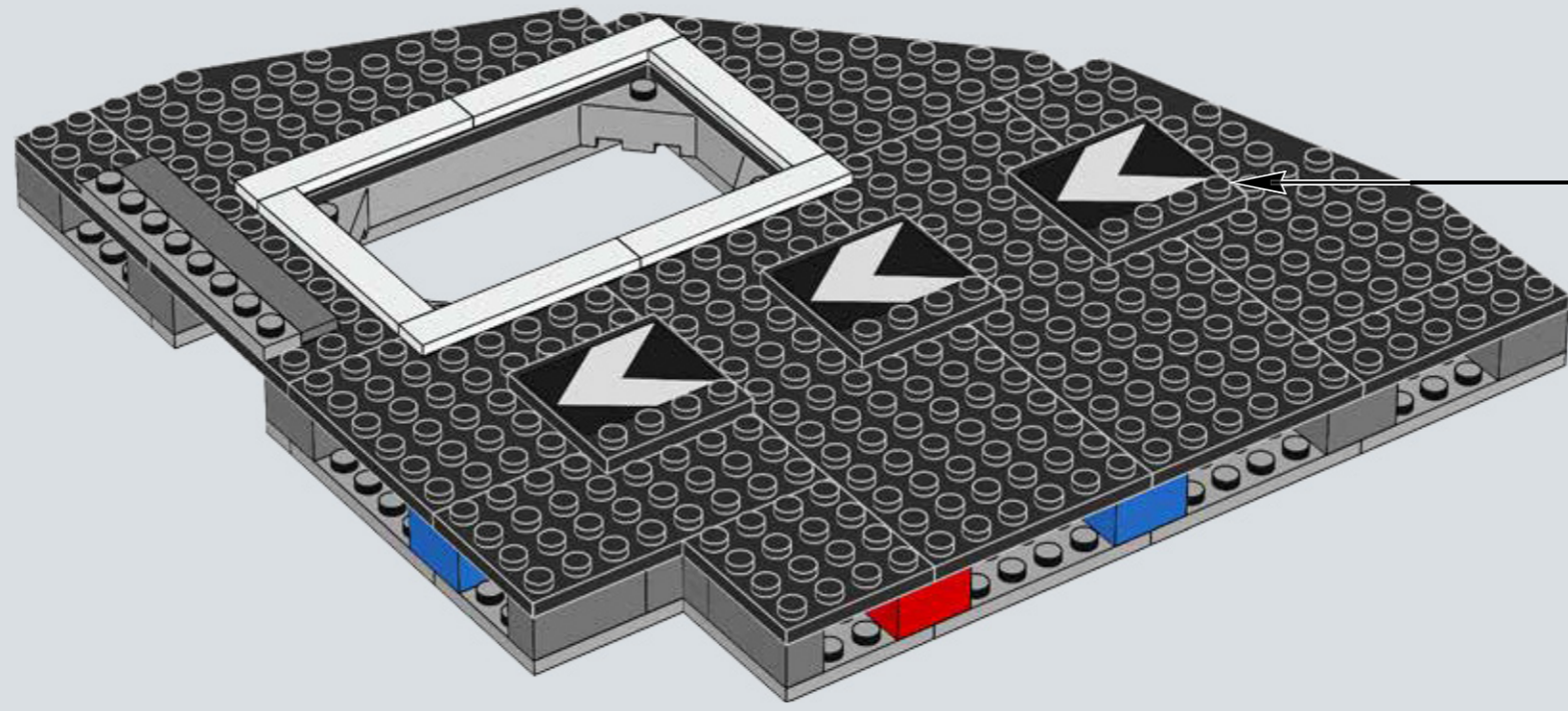

222

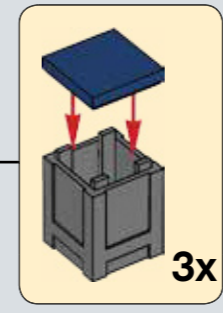
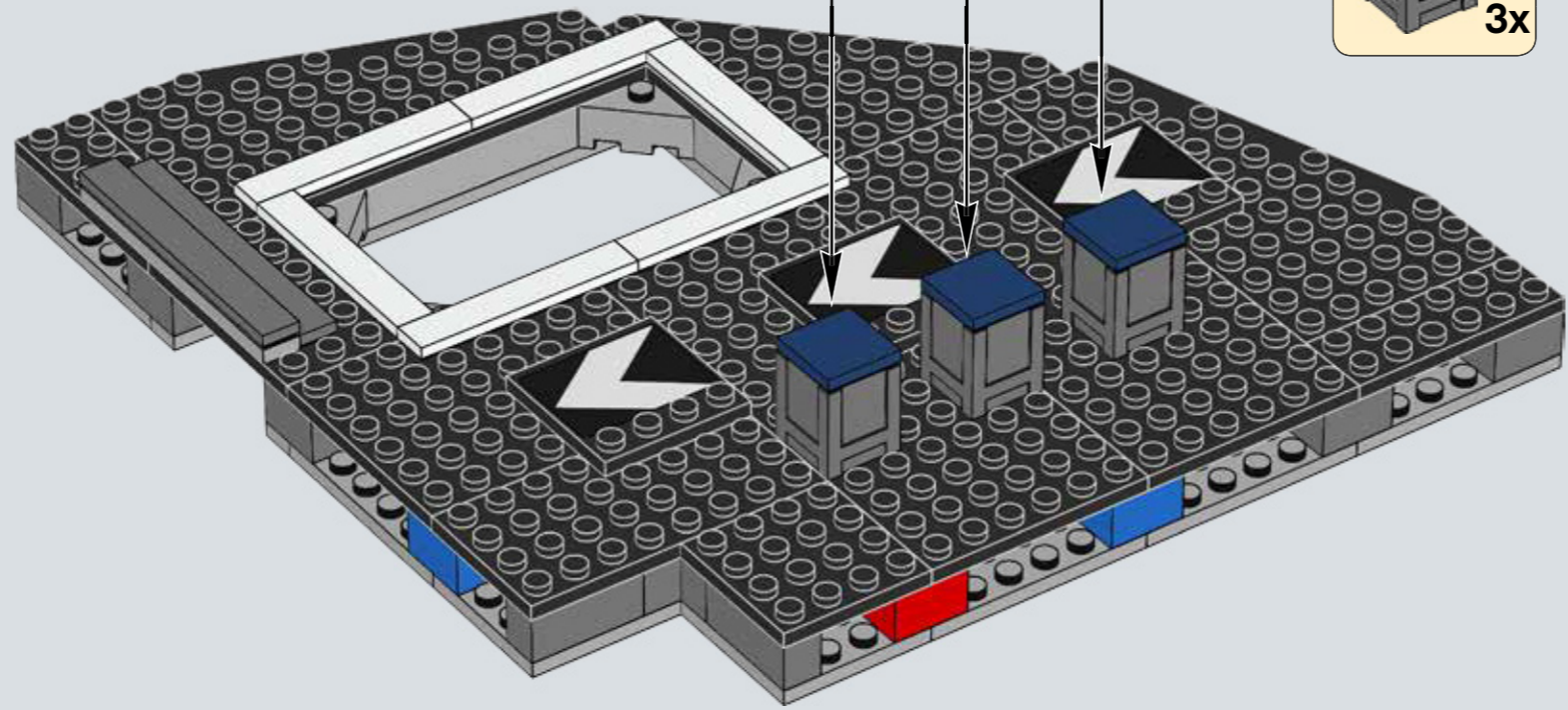

223

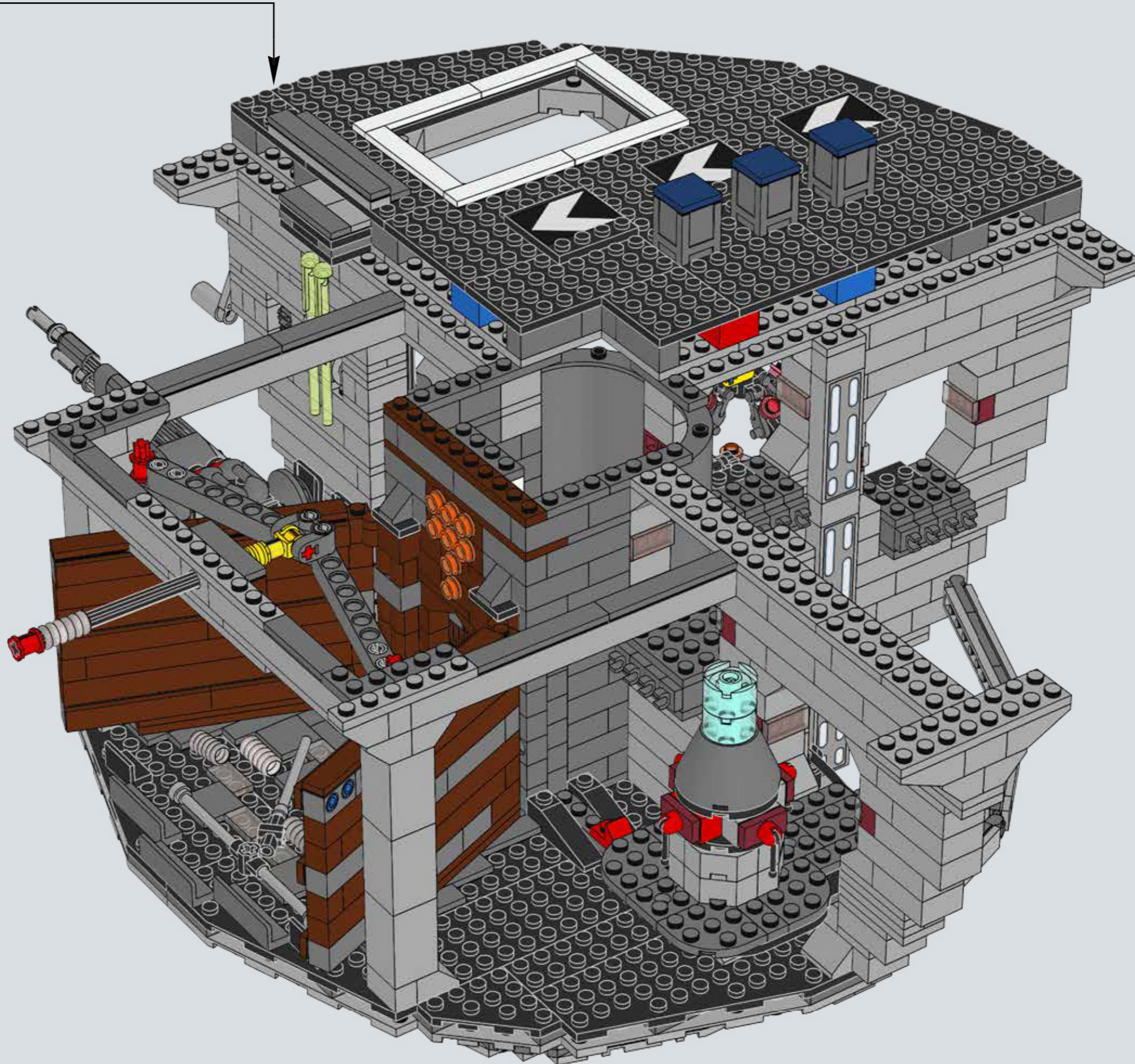

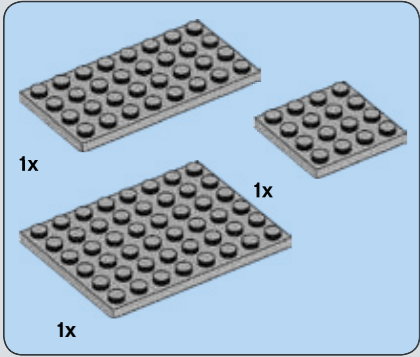
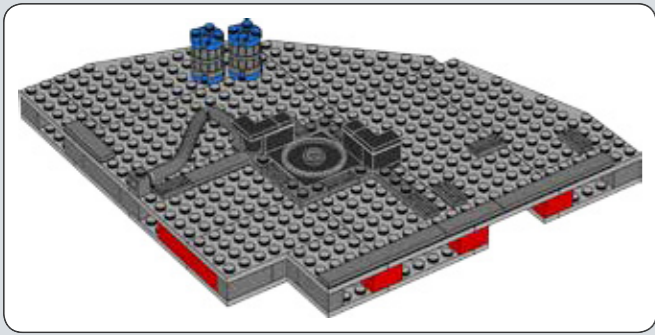

224

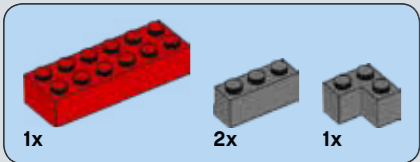
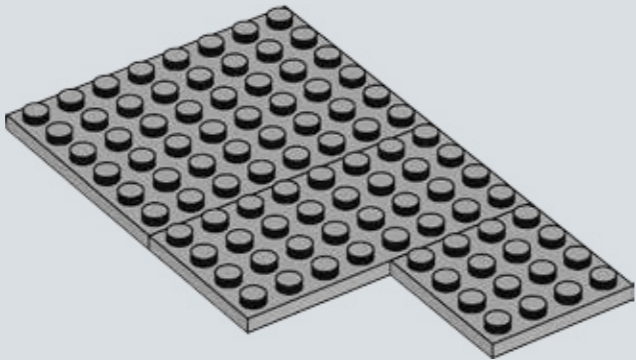

225

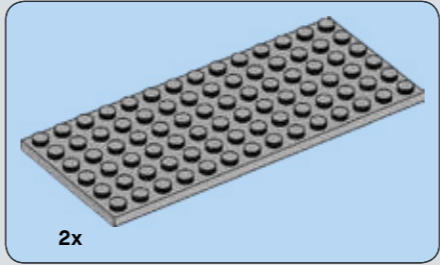
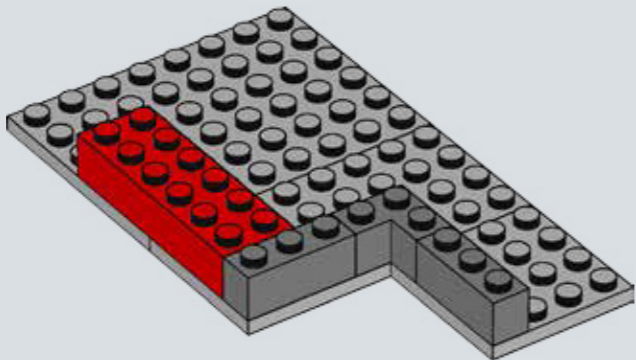

226

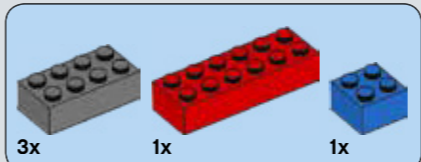
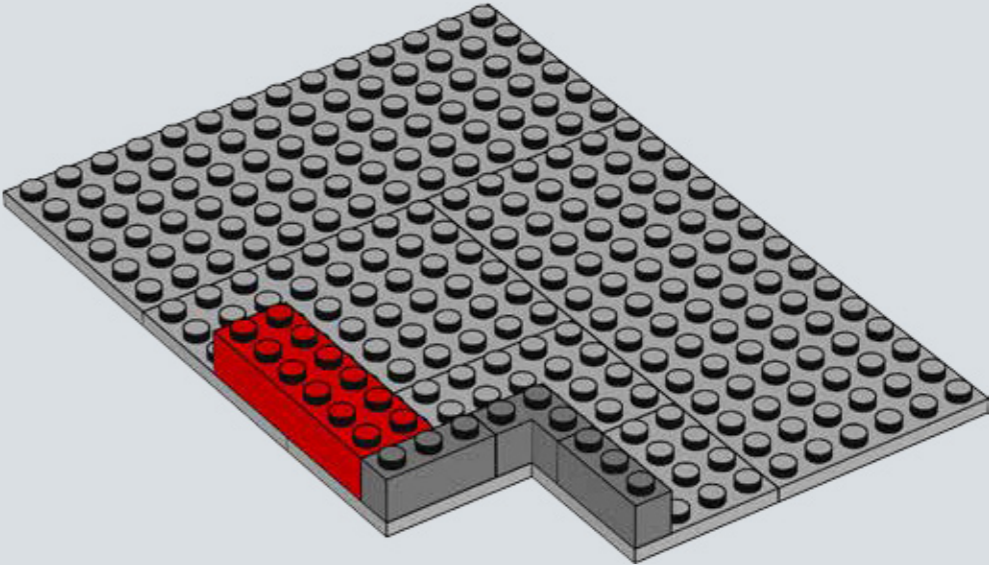

227

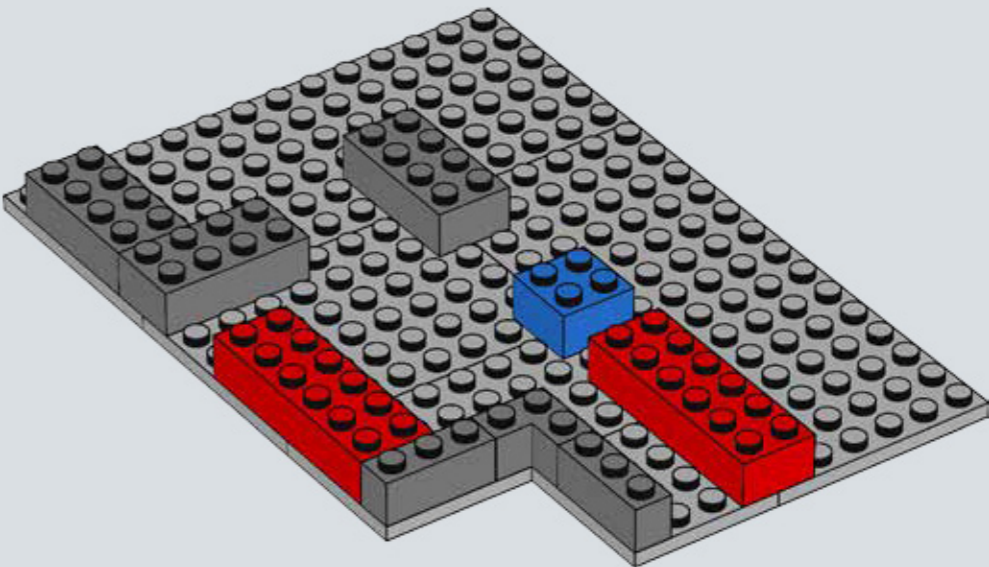

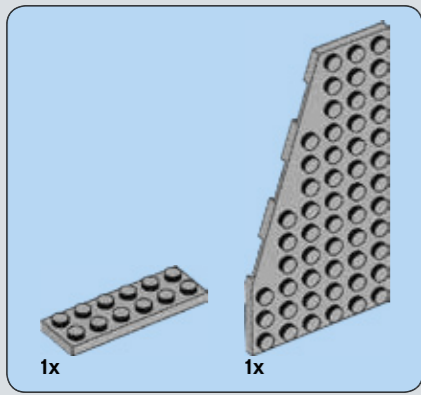

228

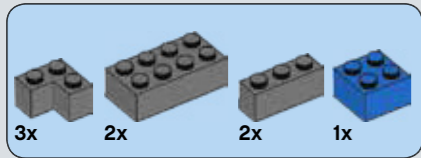
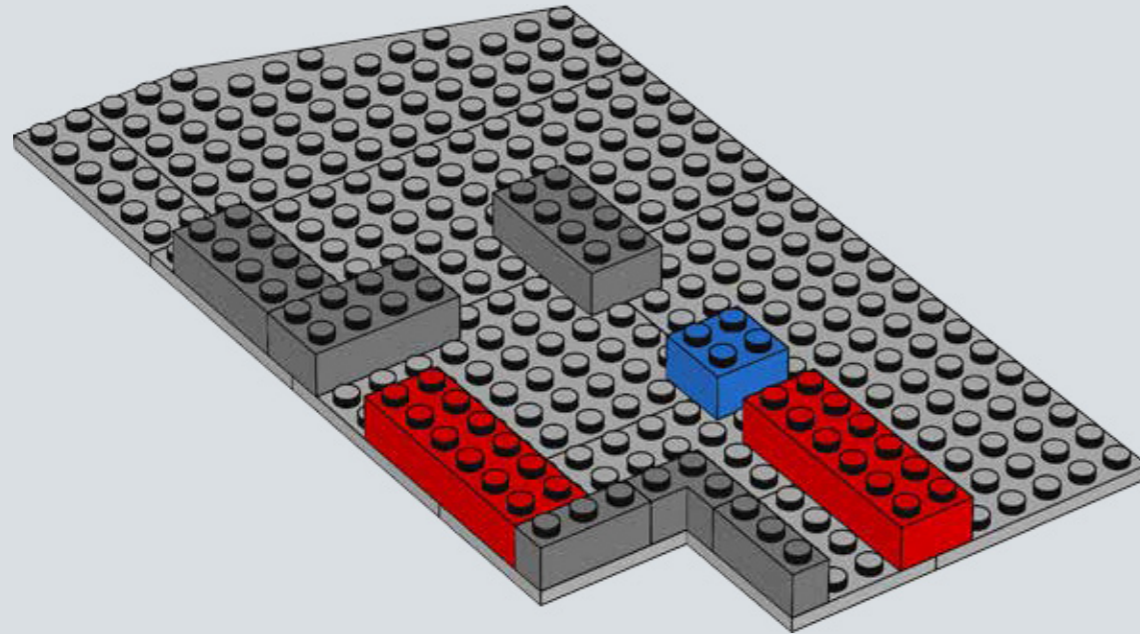

229

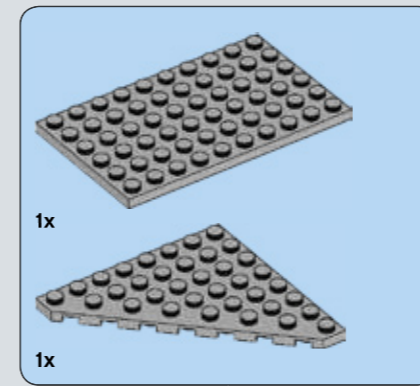
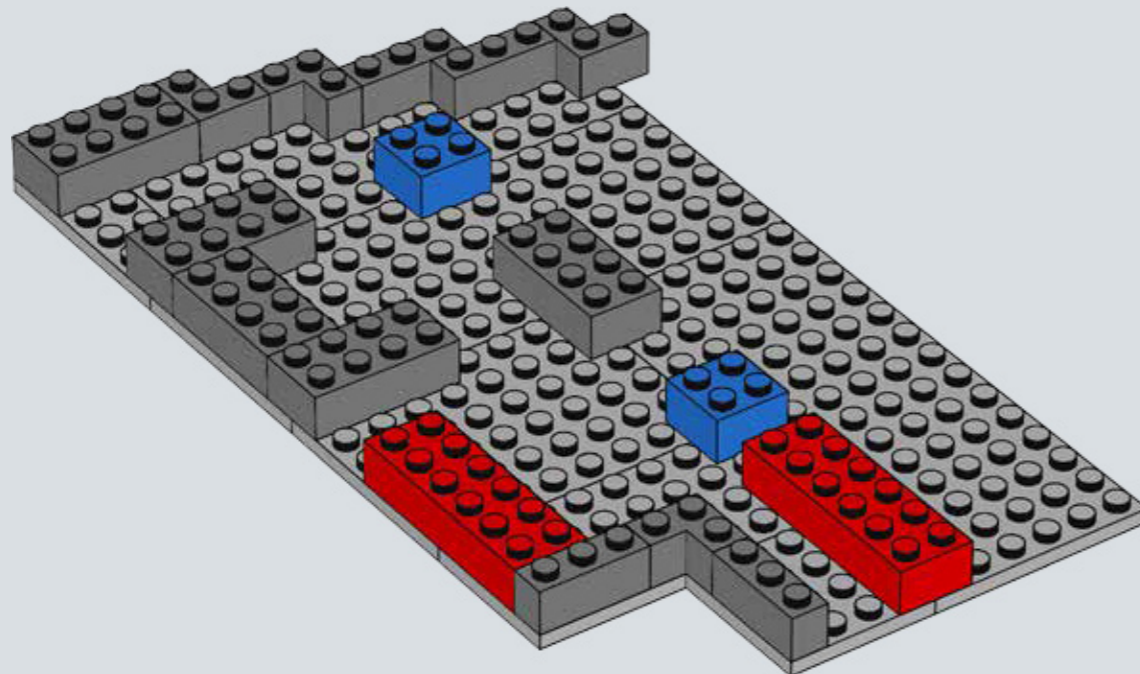

230

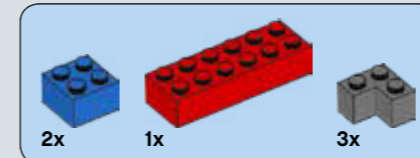
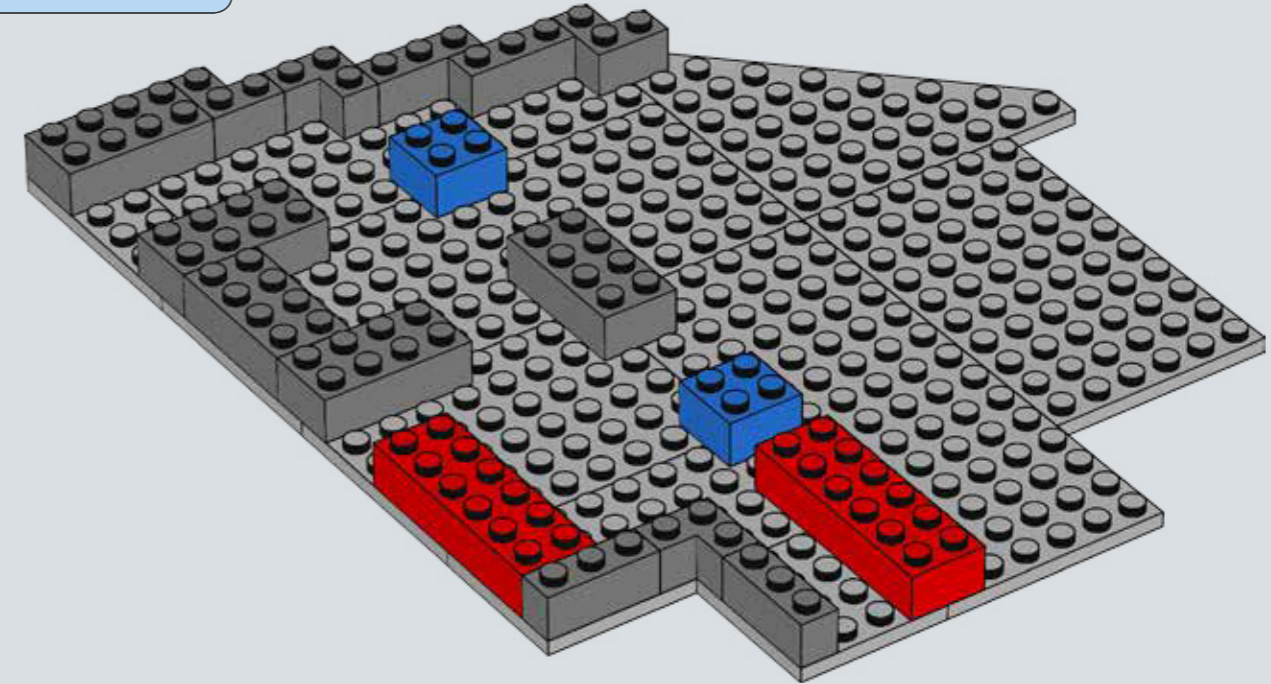

231

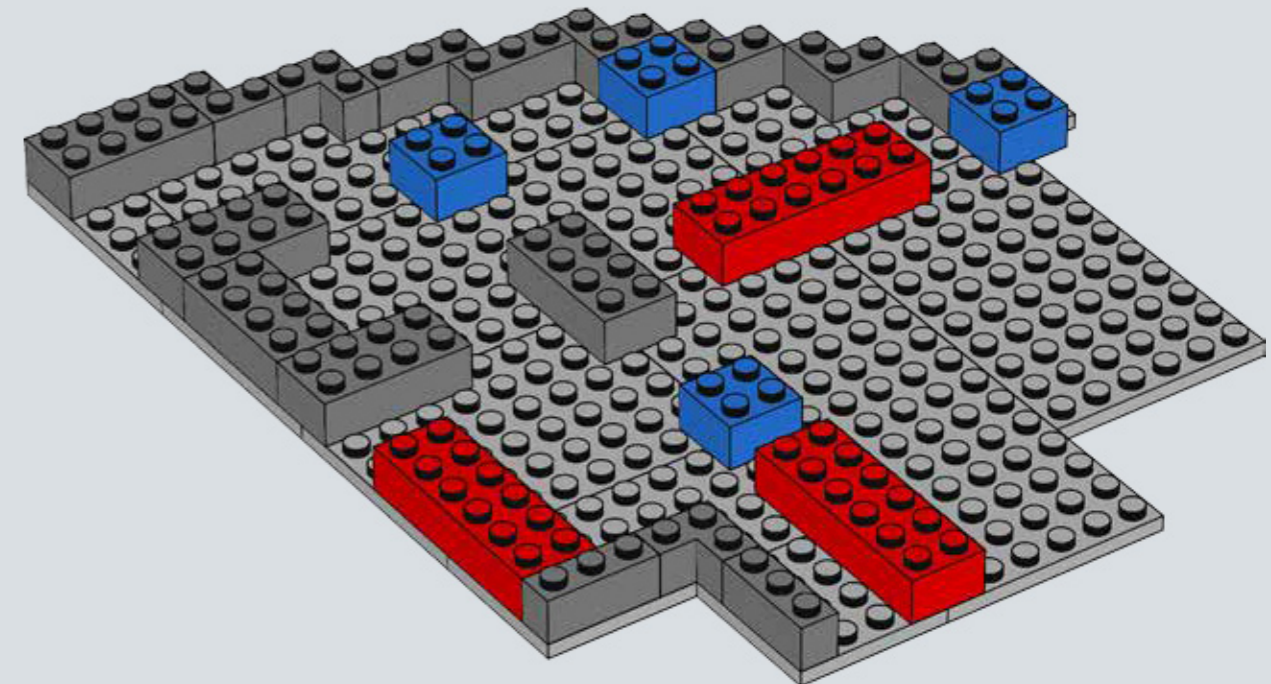

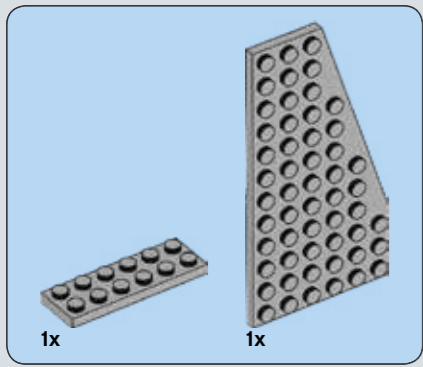

232

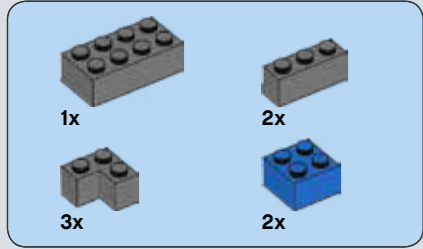
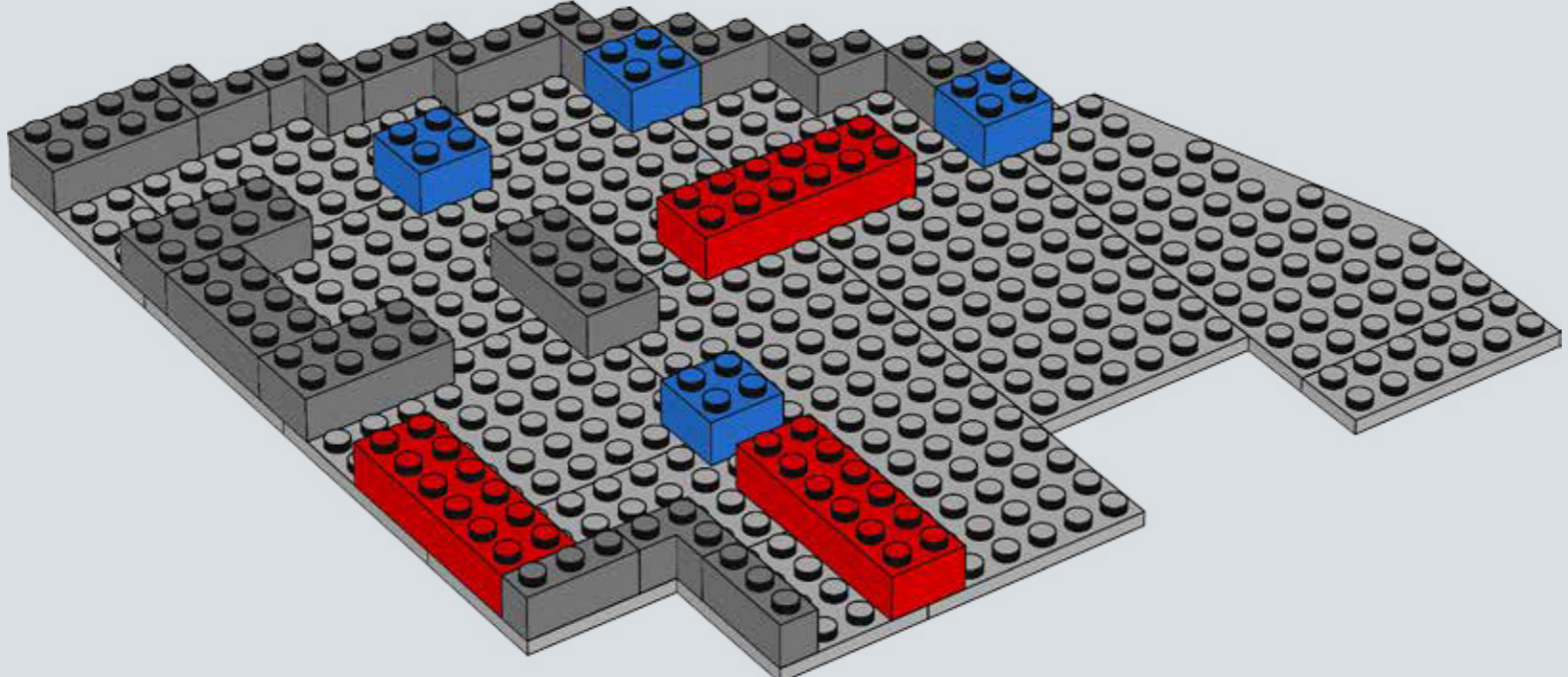

233

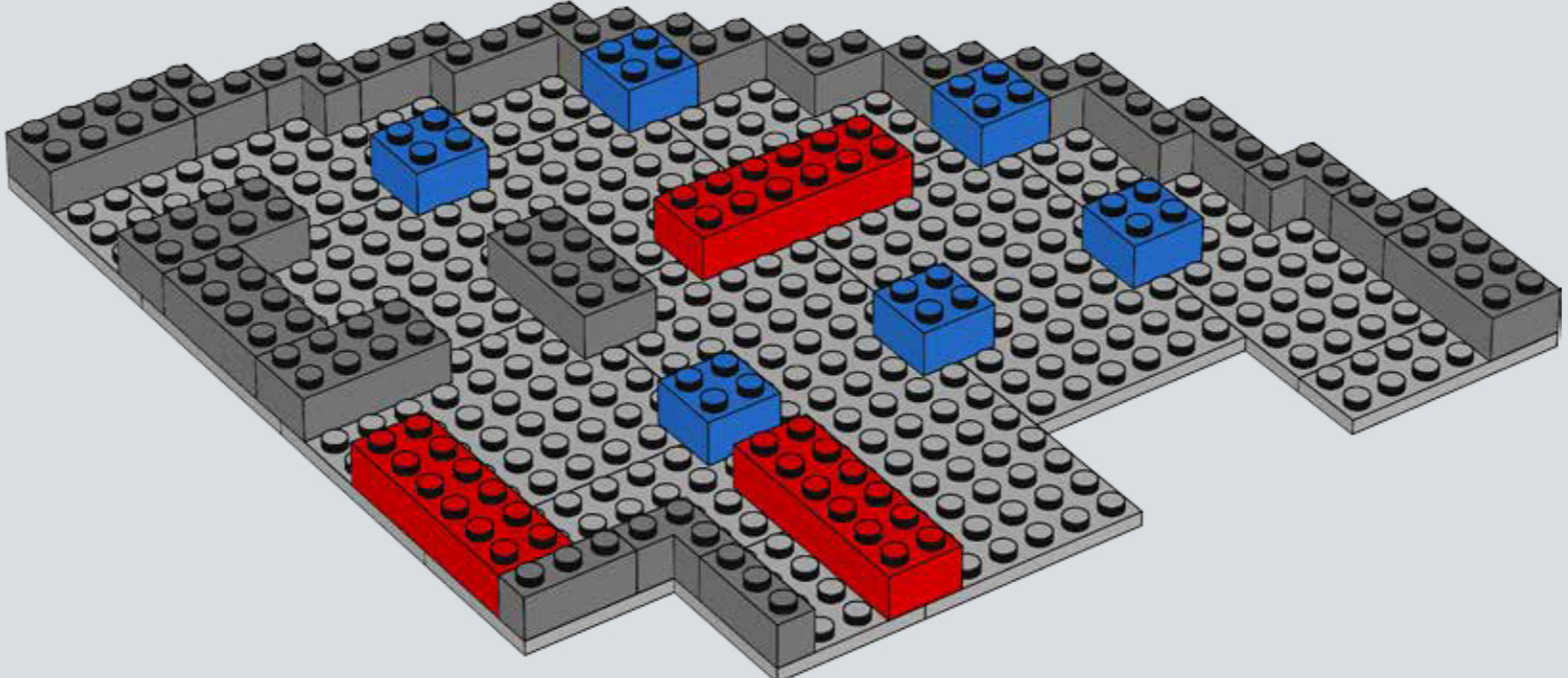

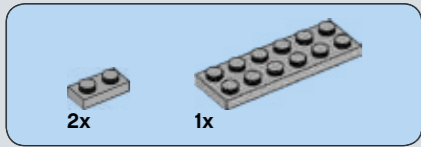

234

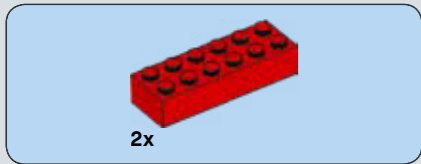
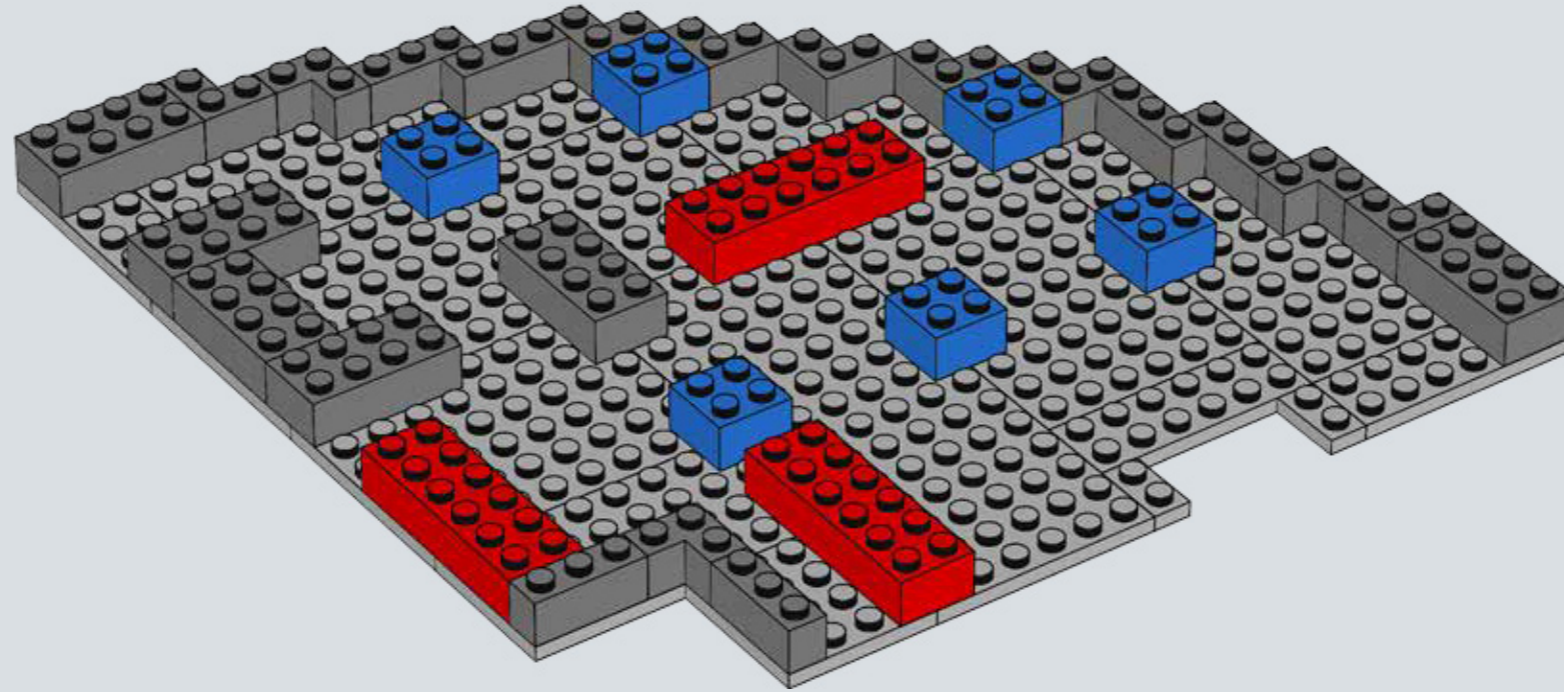

235

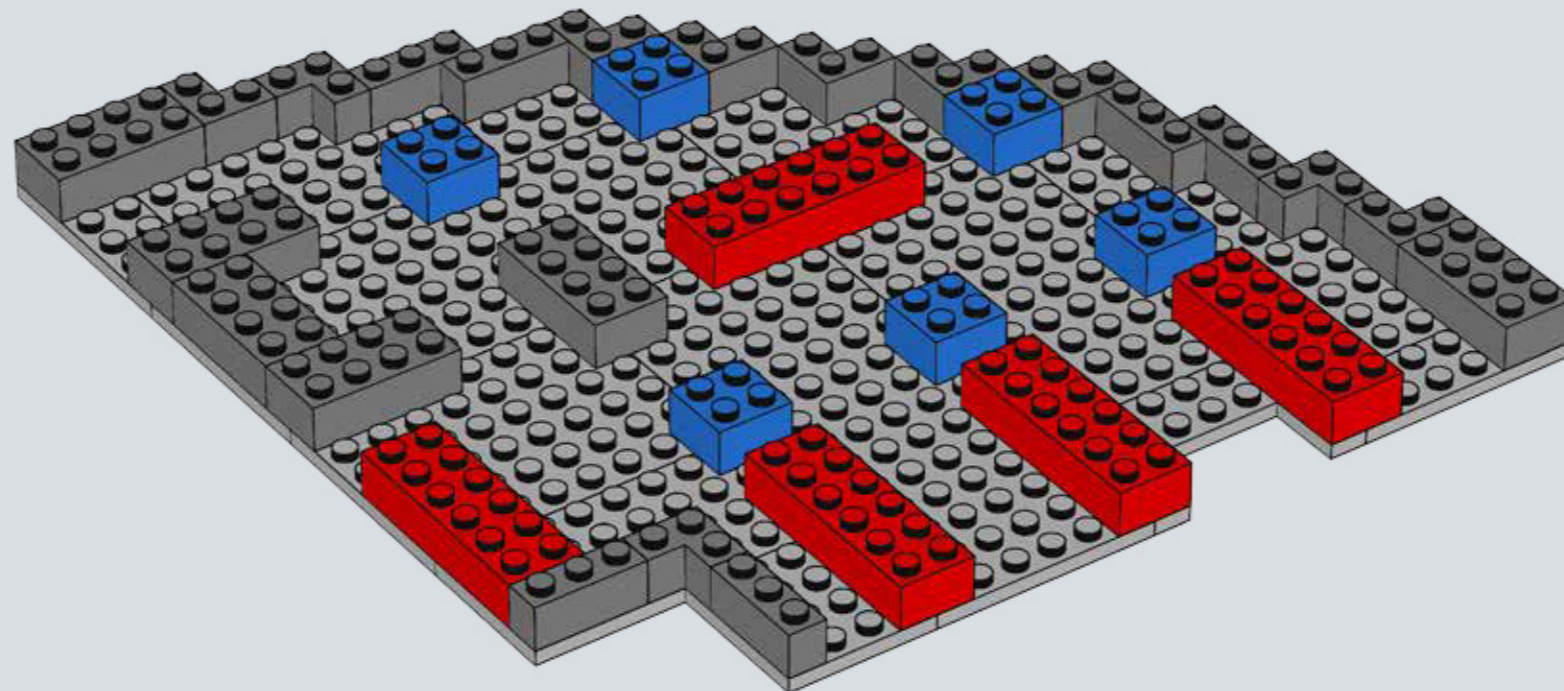

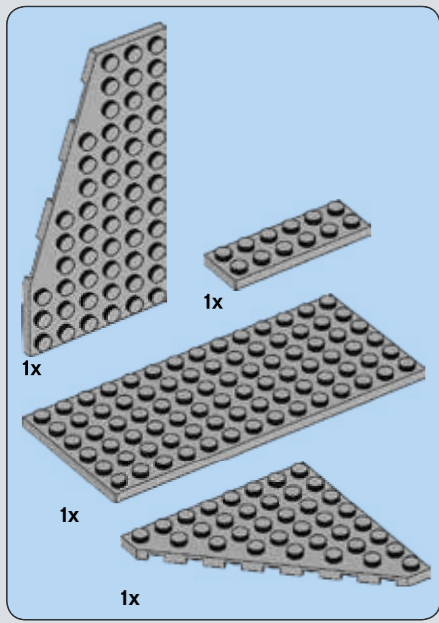

**236**

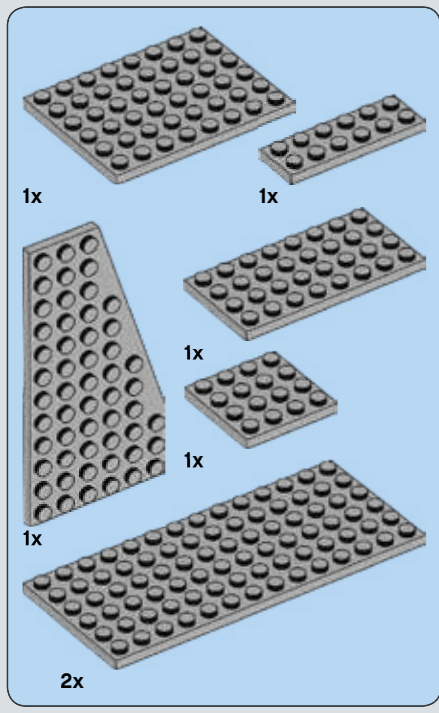
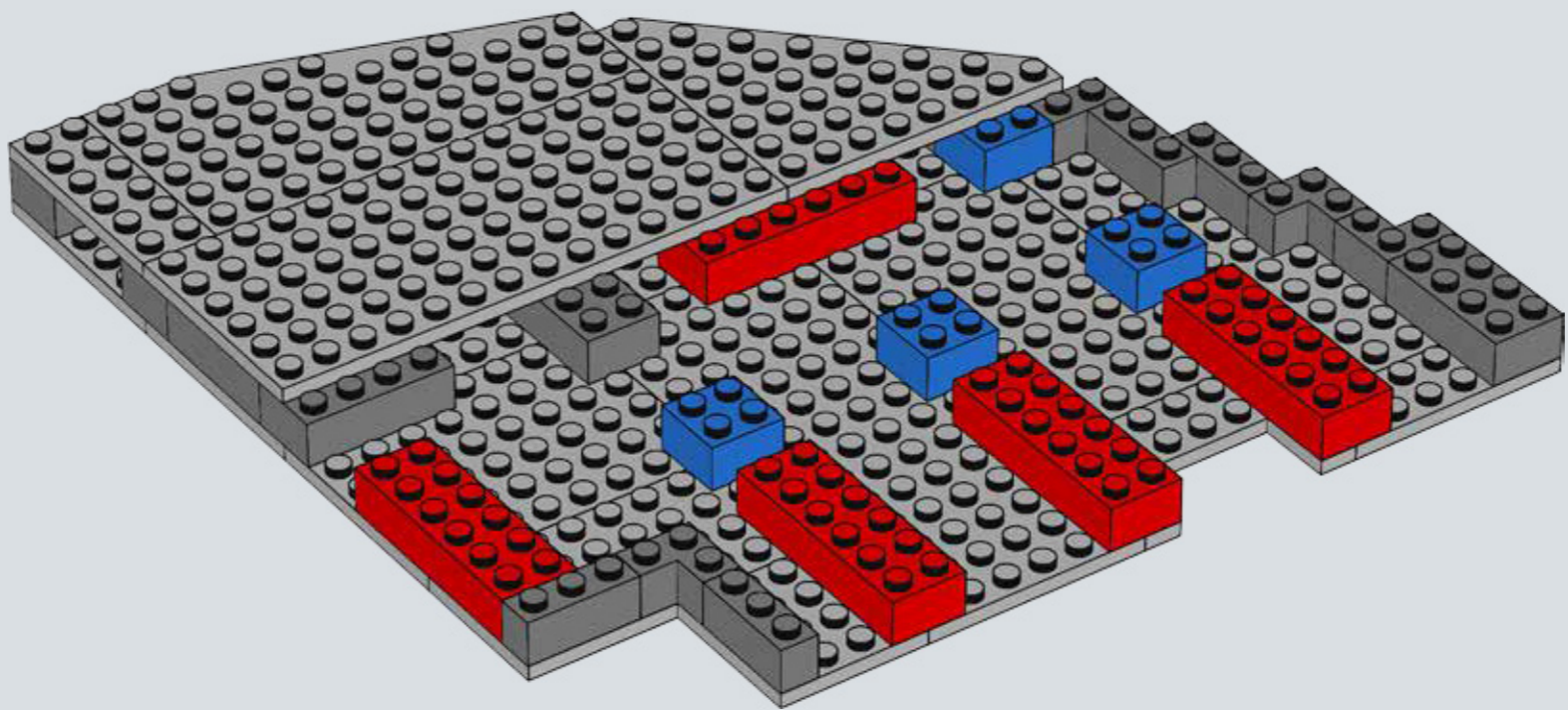

**237**

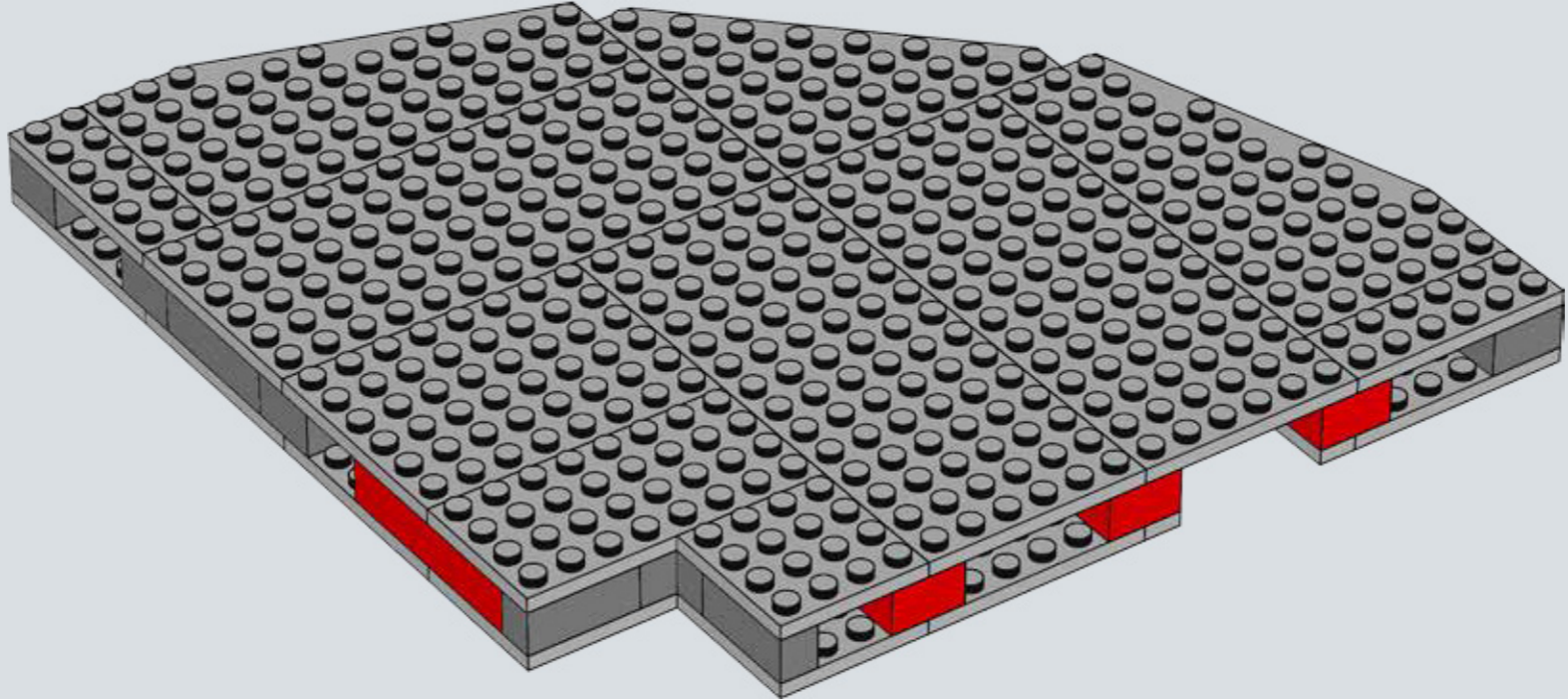



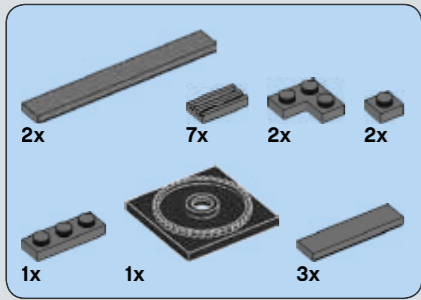

**238**

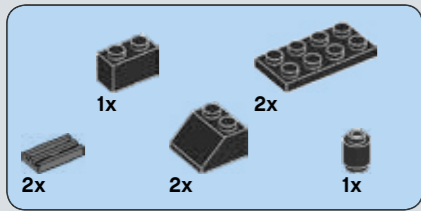
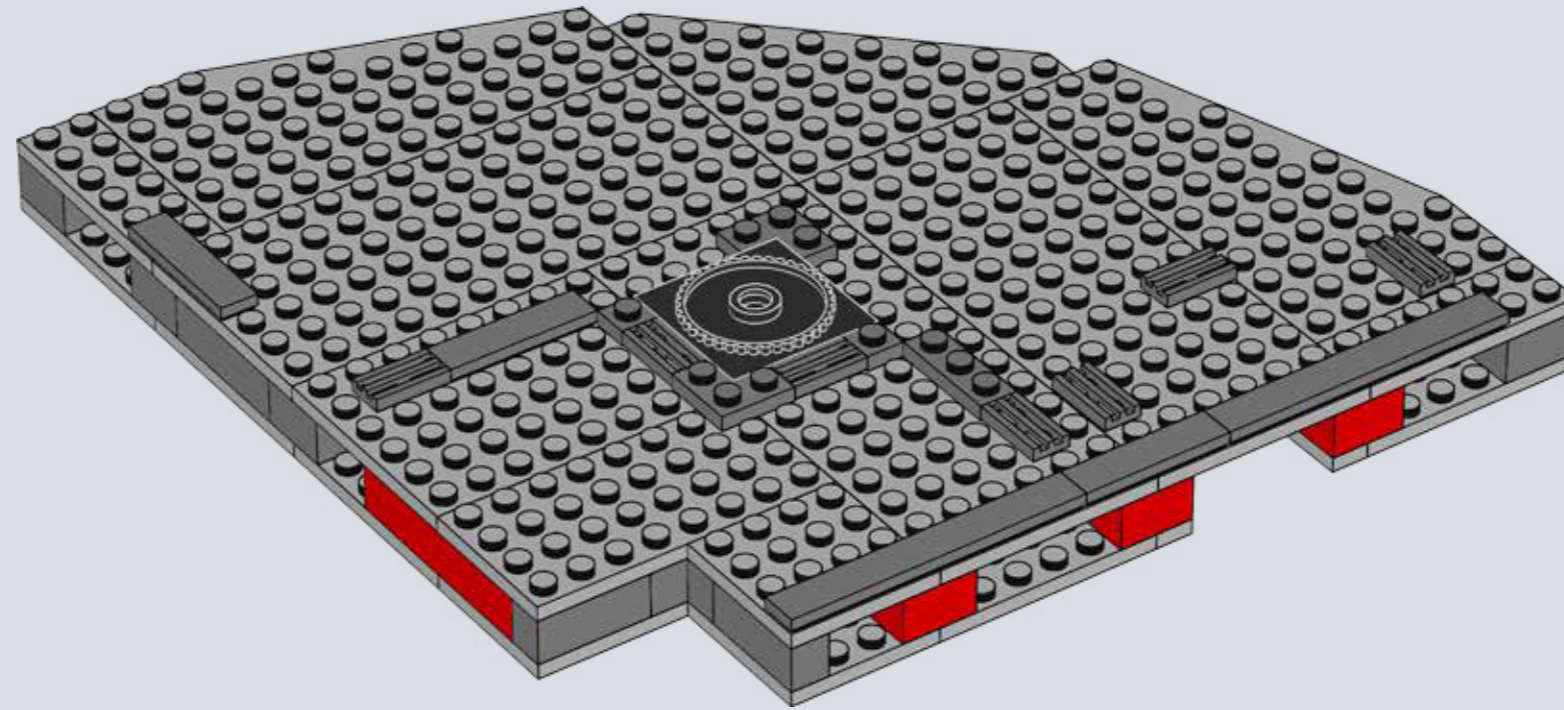

**239**

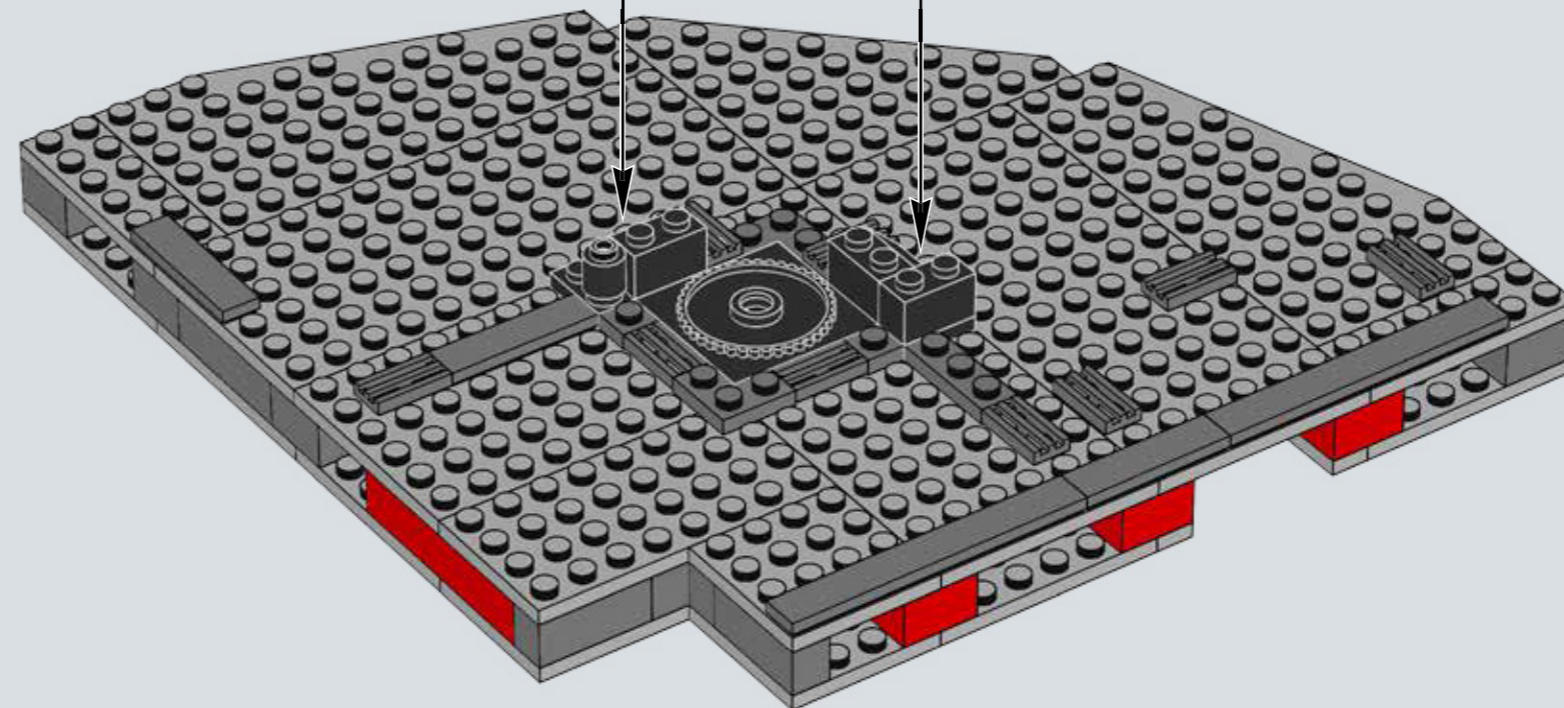
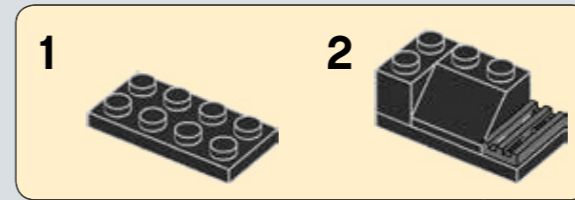
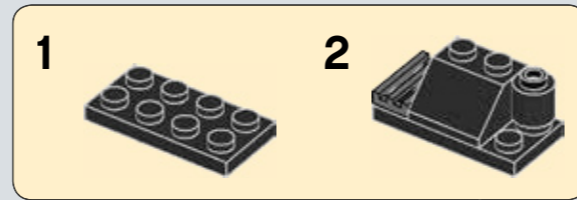

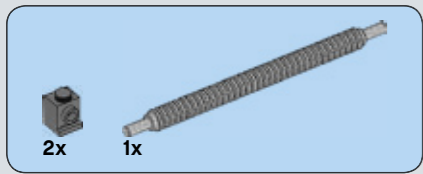

240

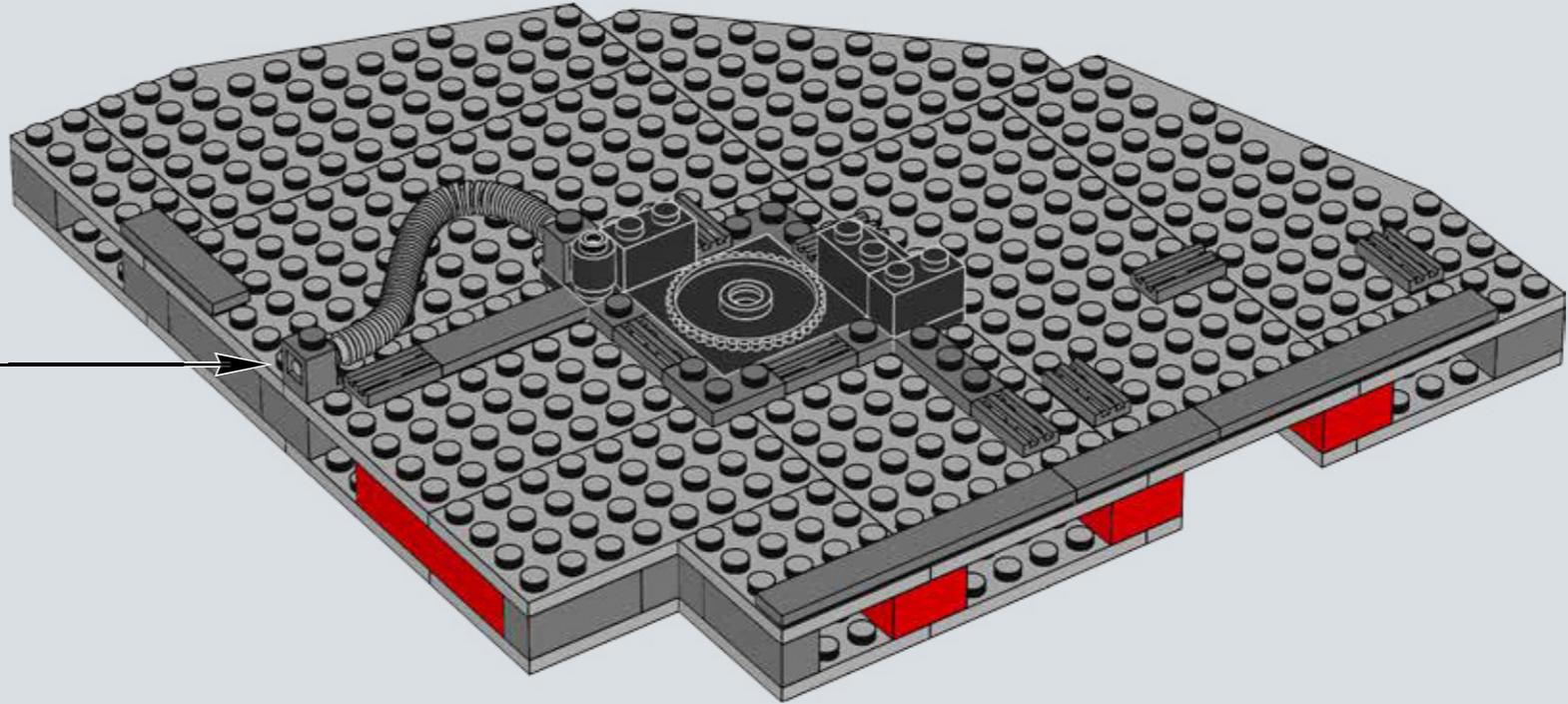
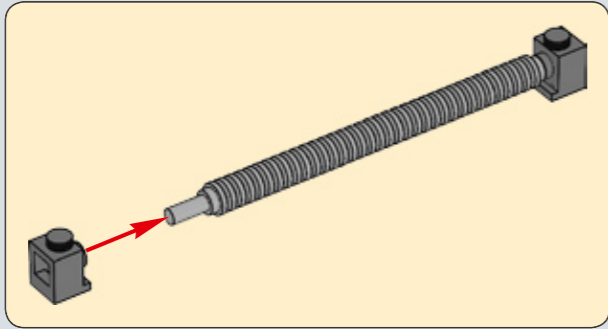

241

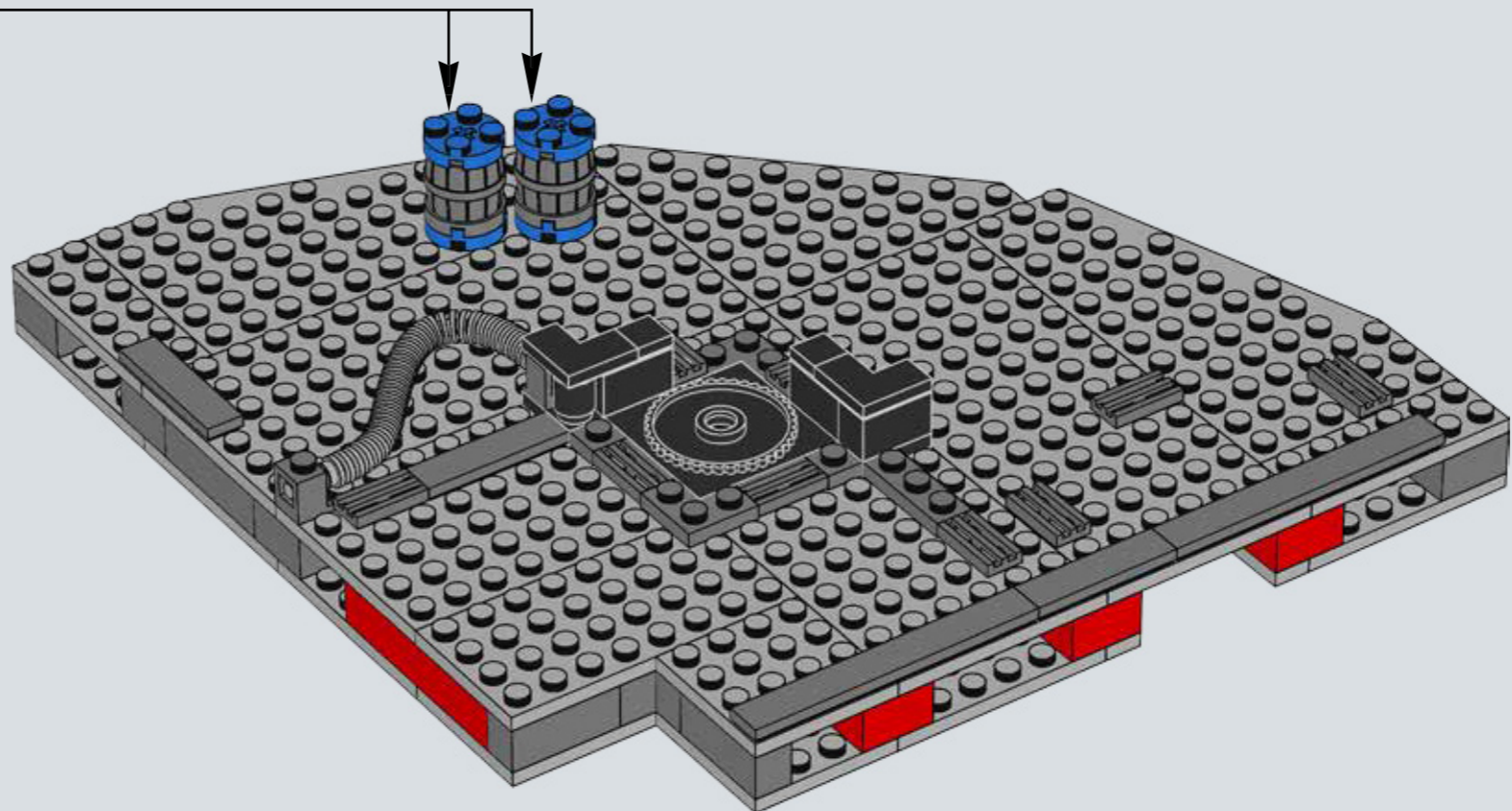
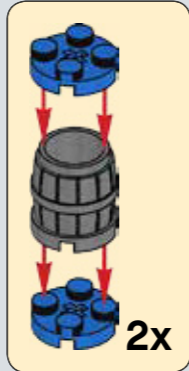

242

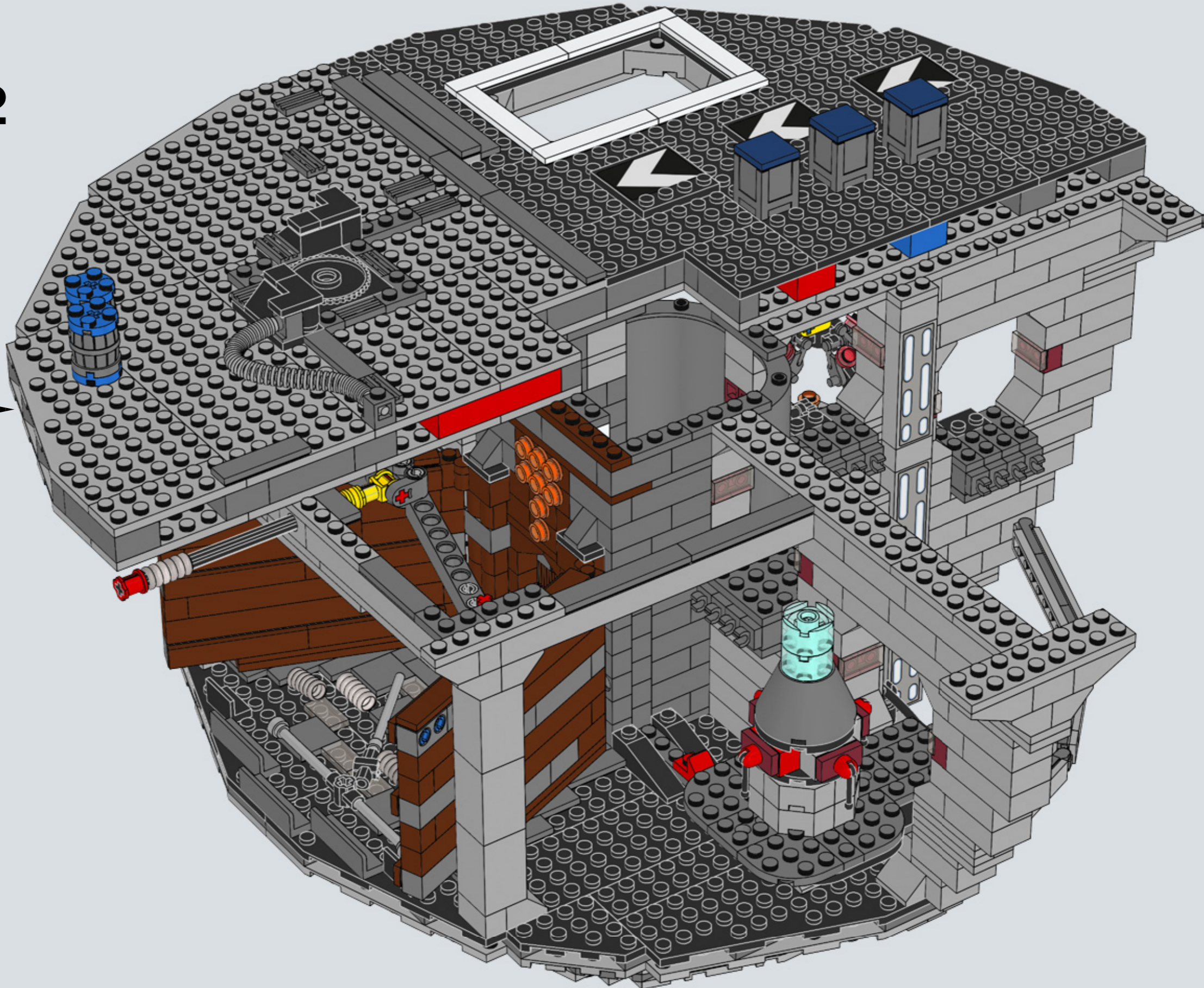

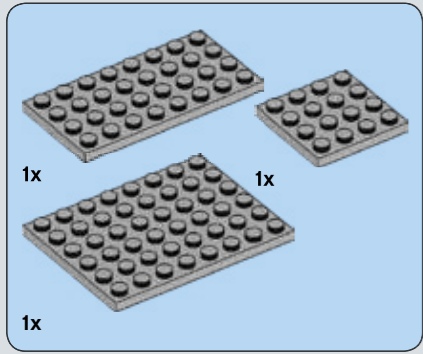
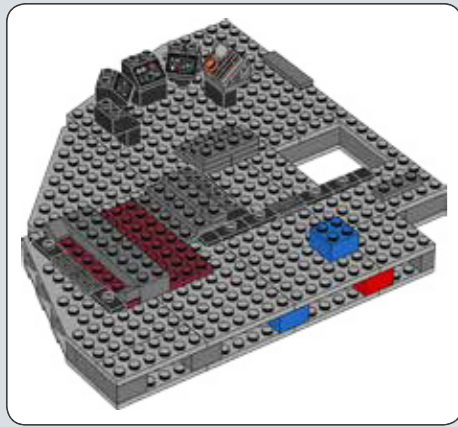

243

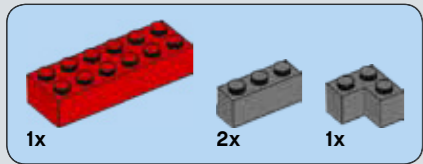
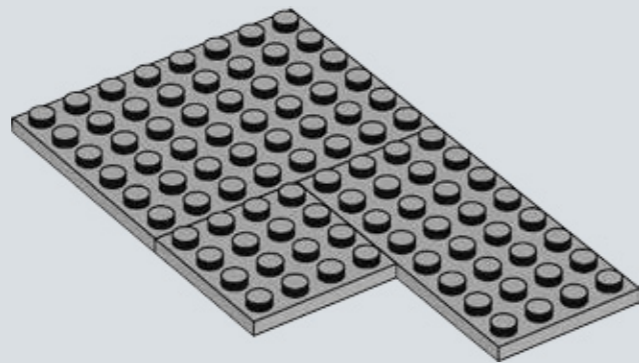

244

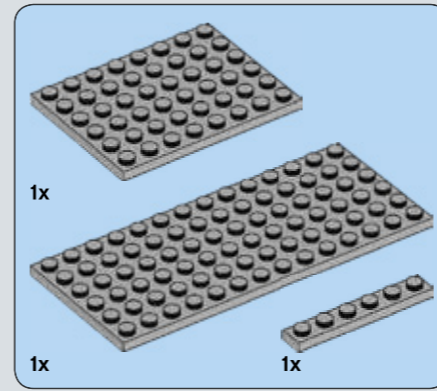
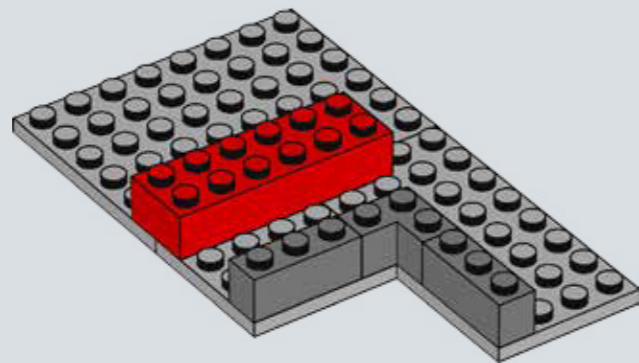

245

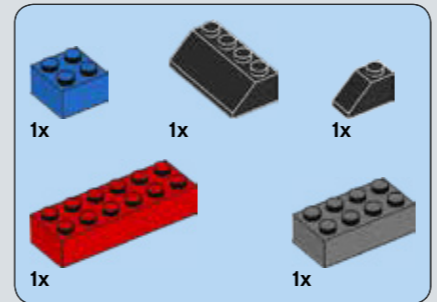
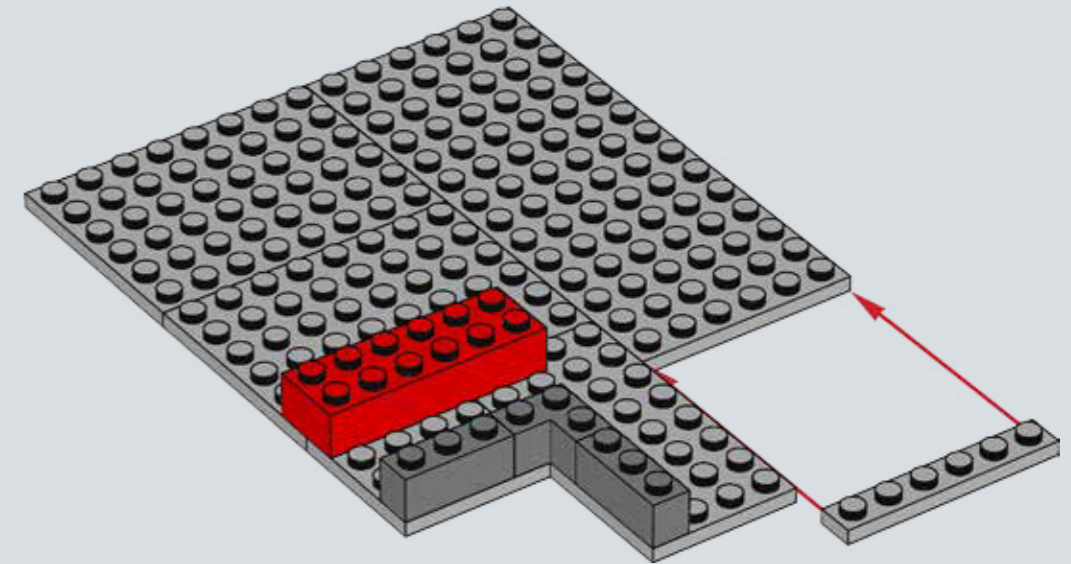

246

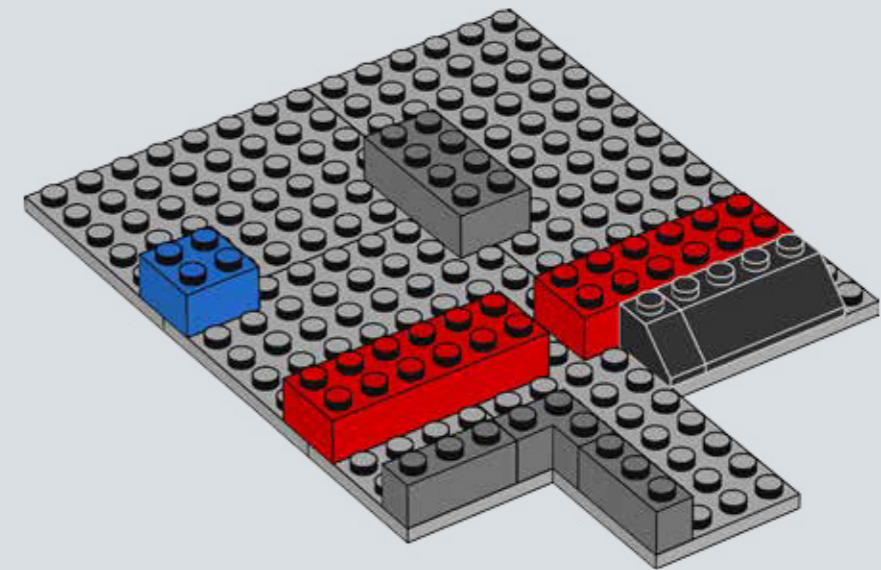

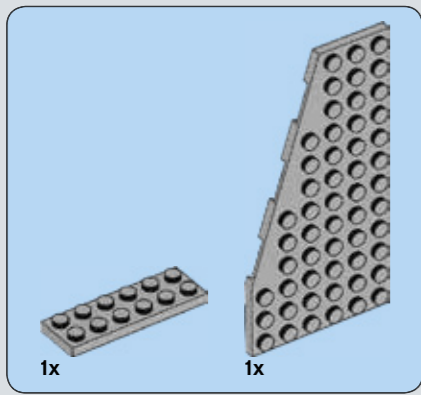

247

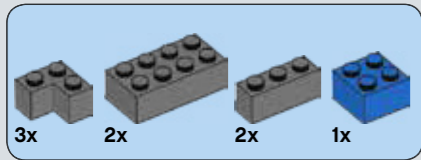
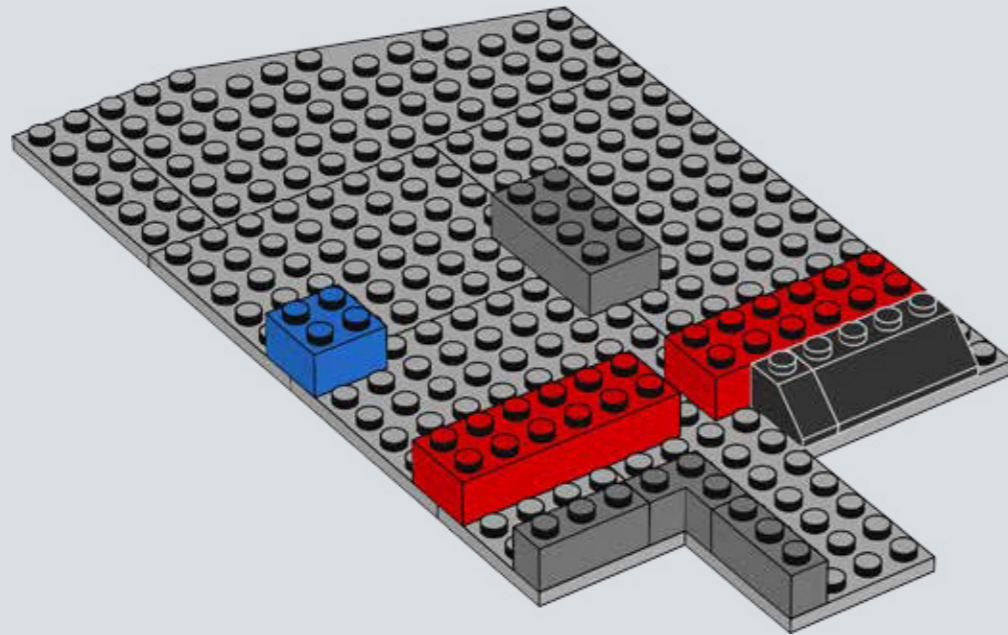

248

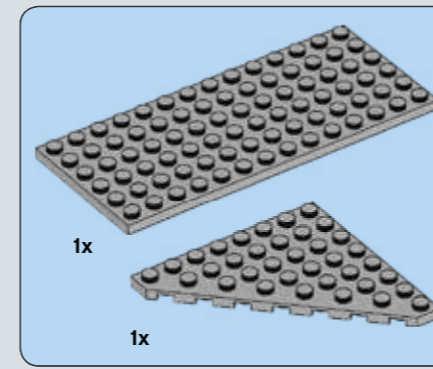
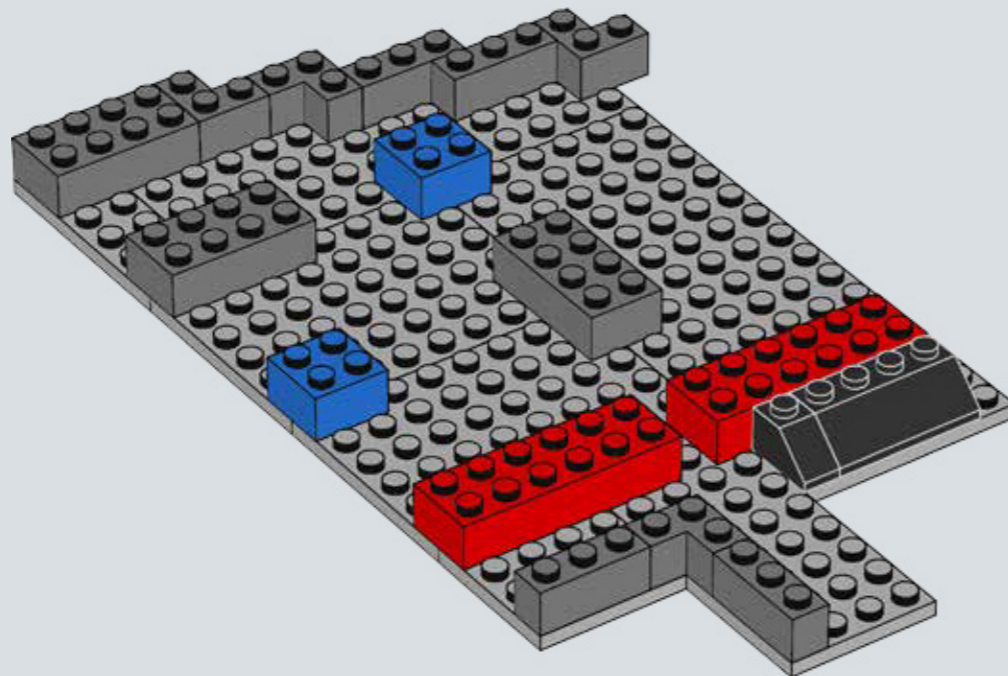

249

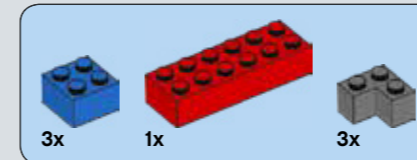
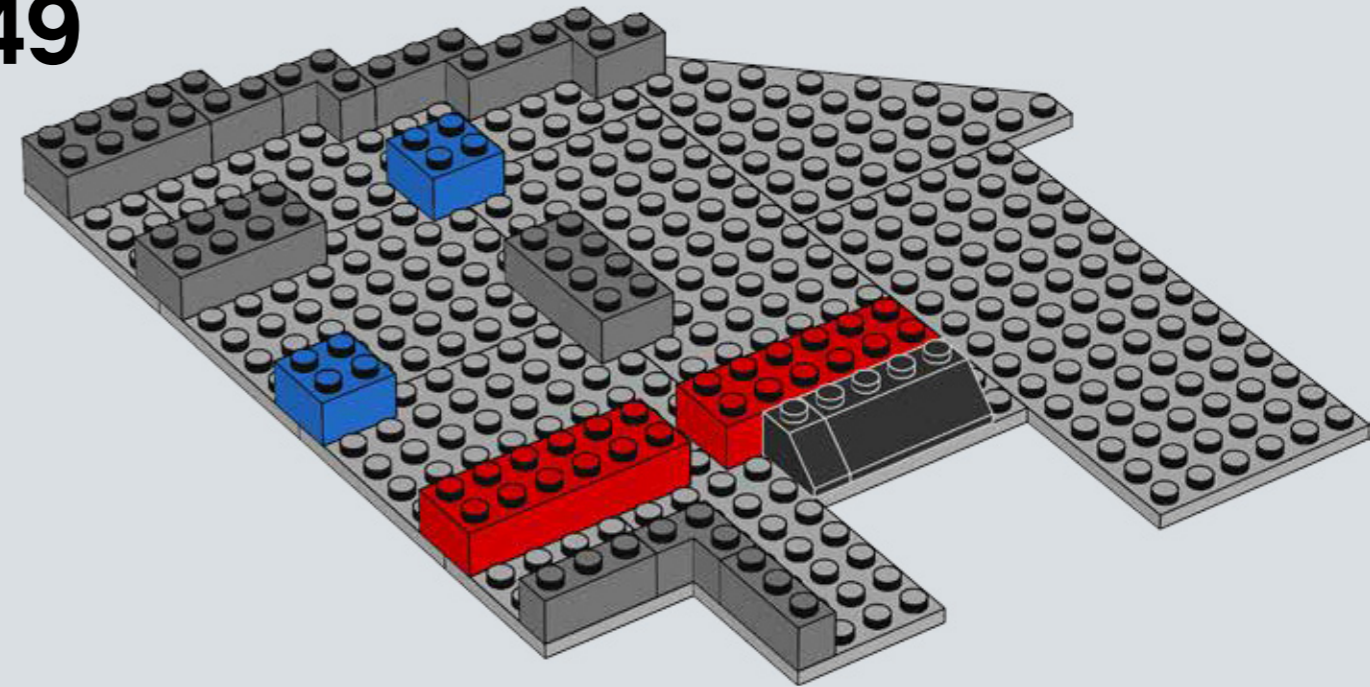

250

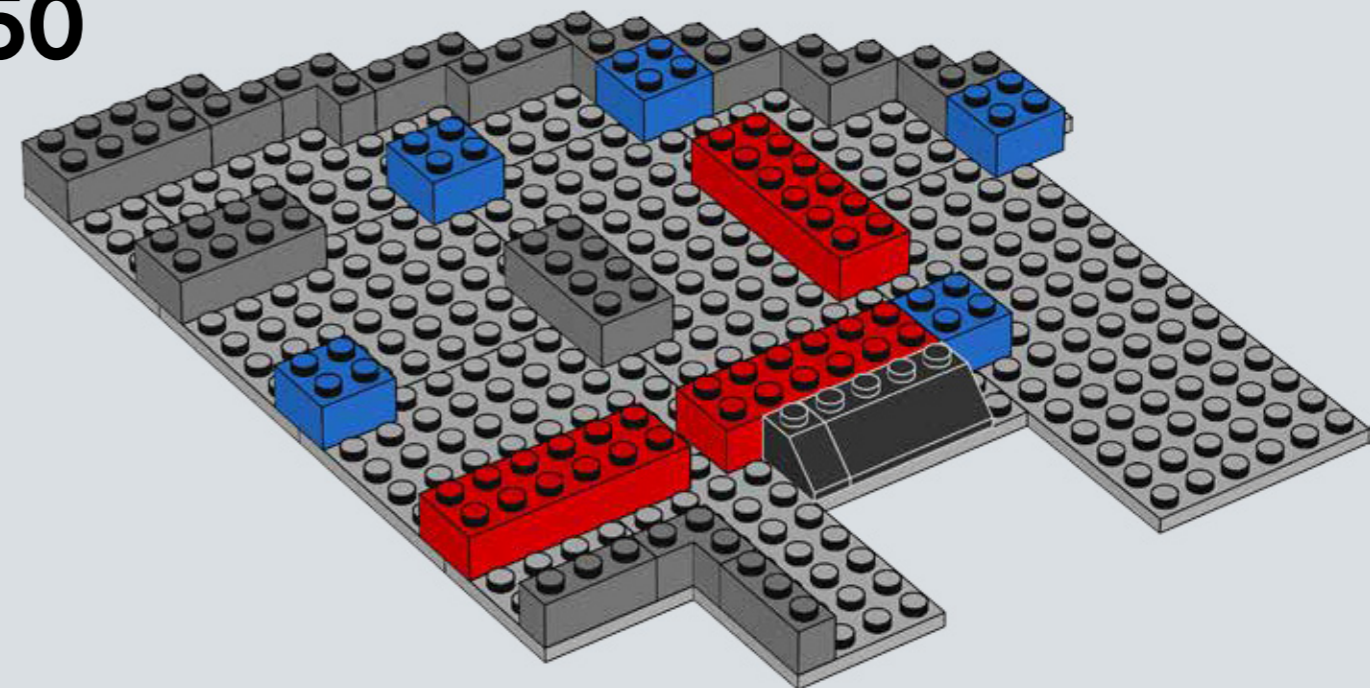

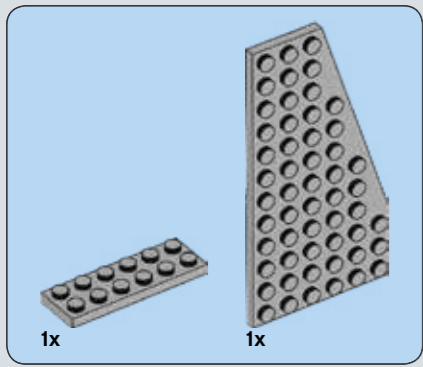

251

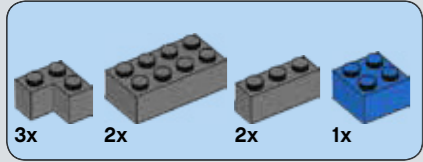
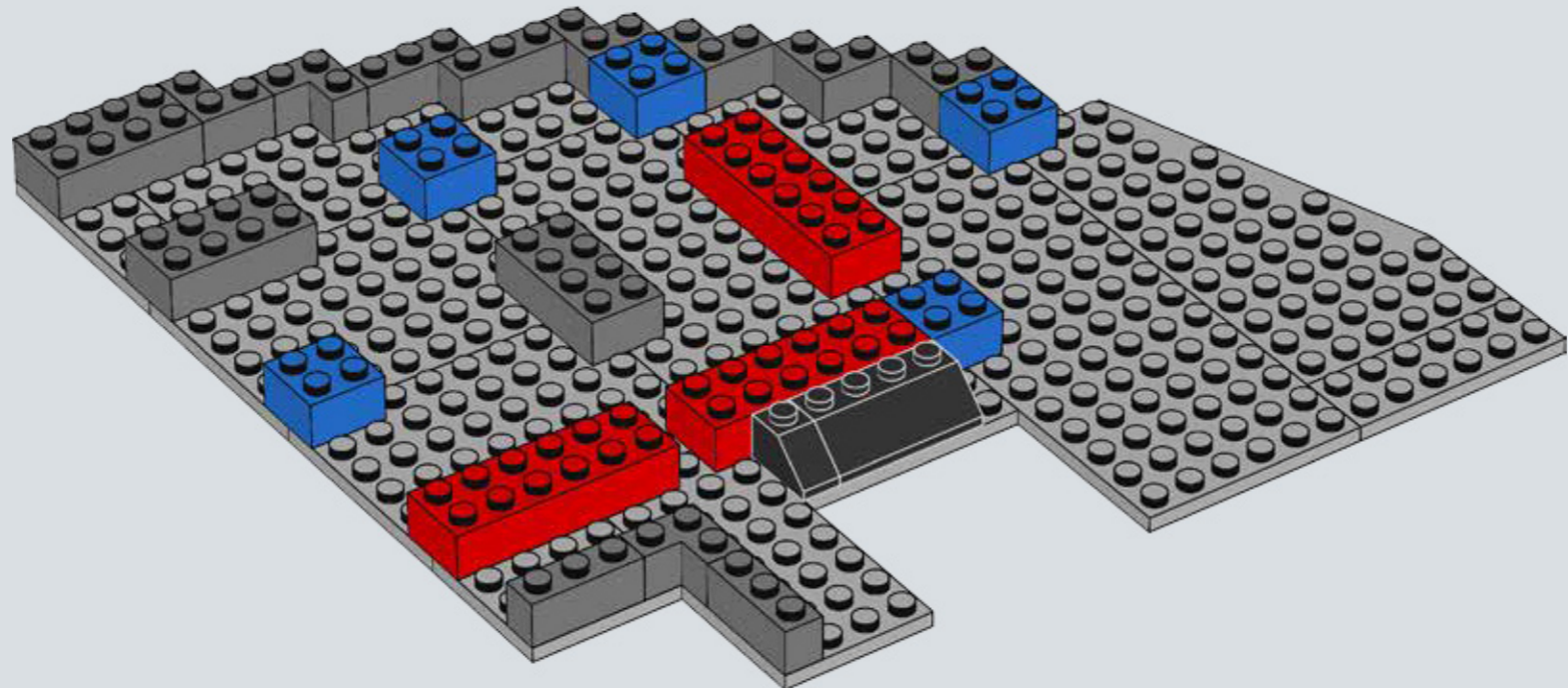

252

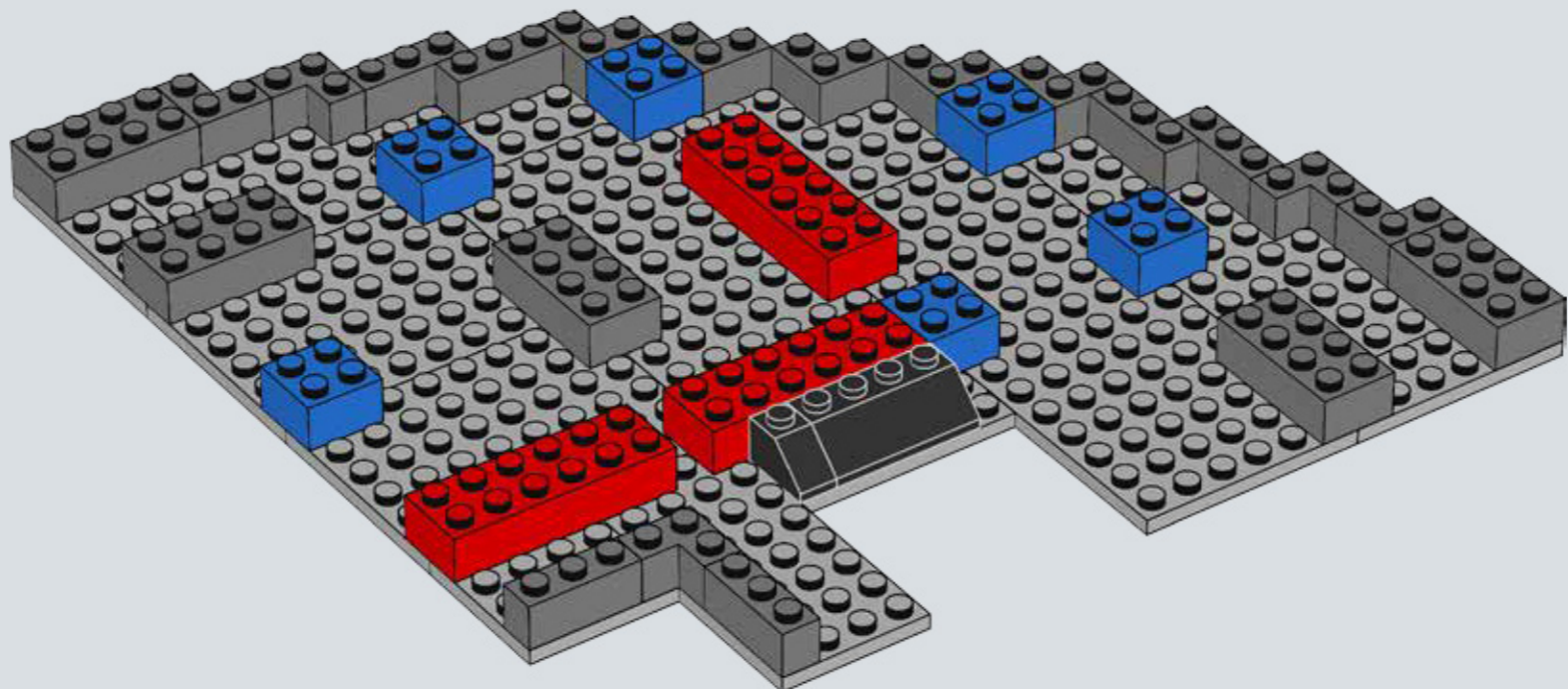

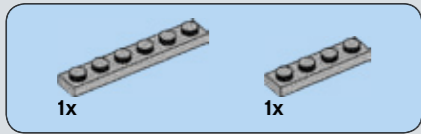

253

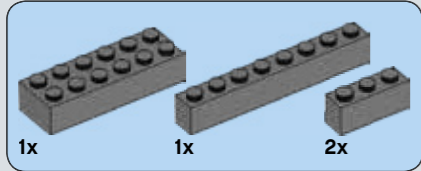
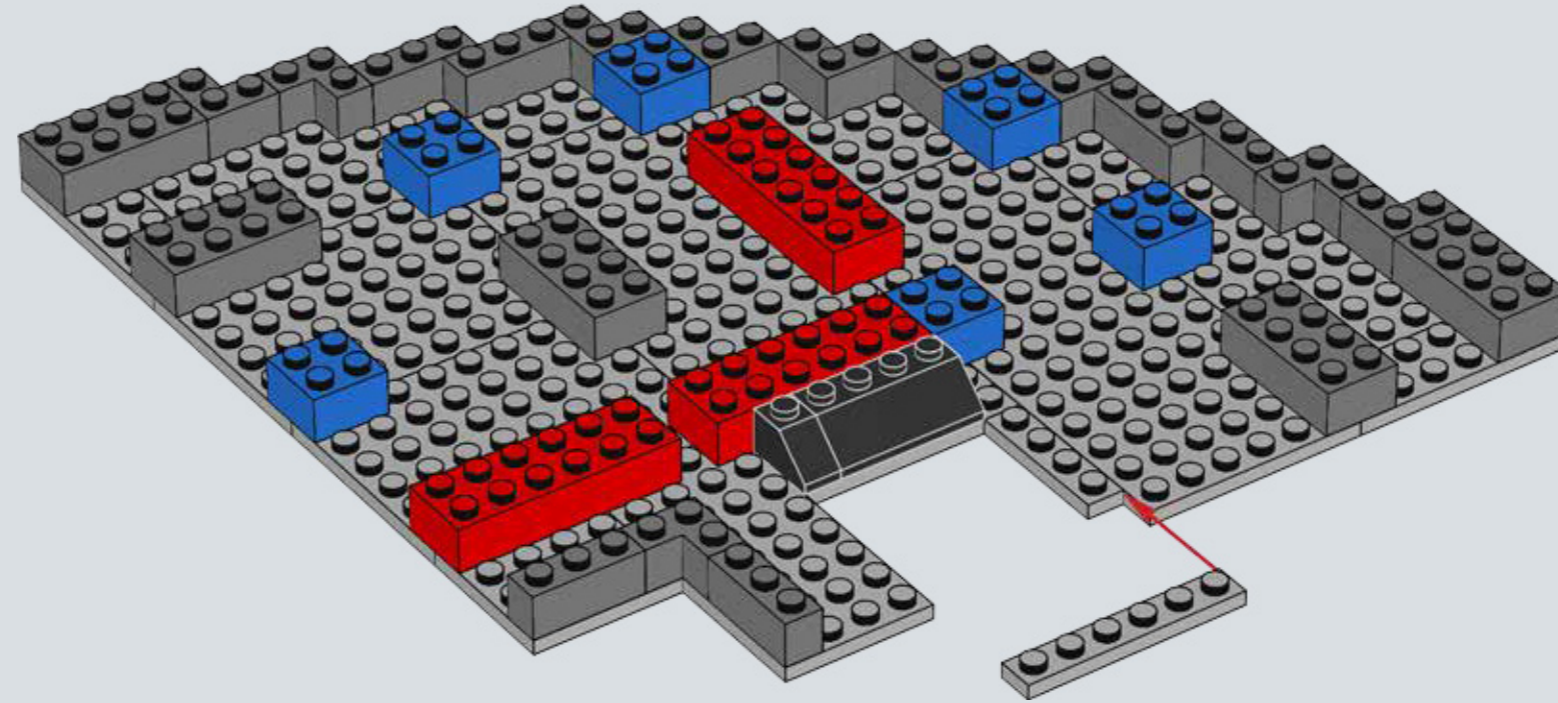

254

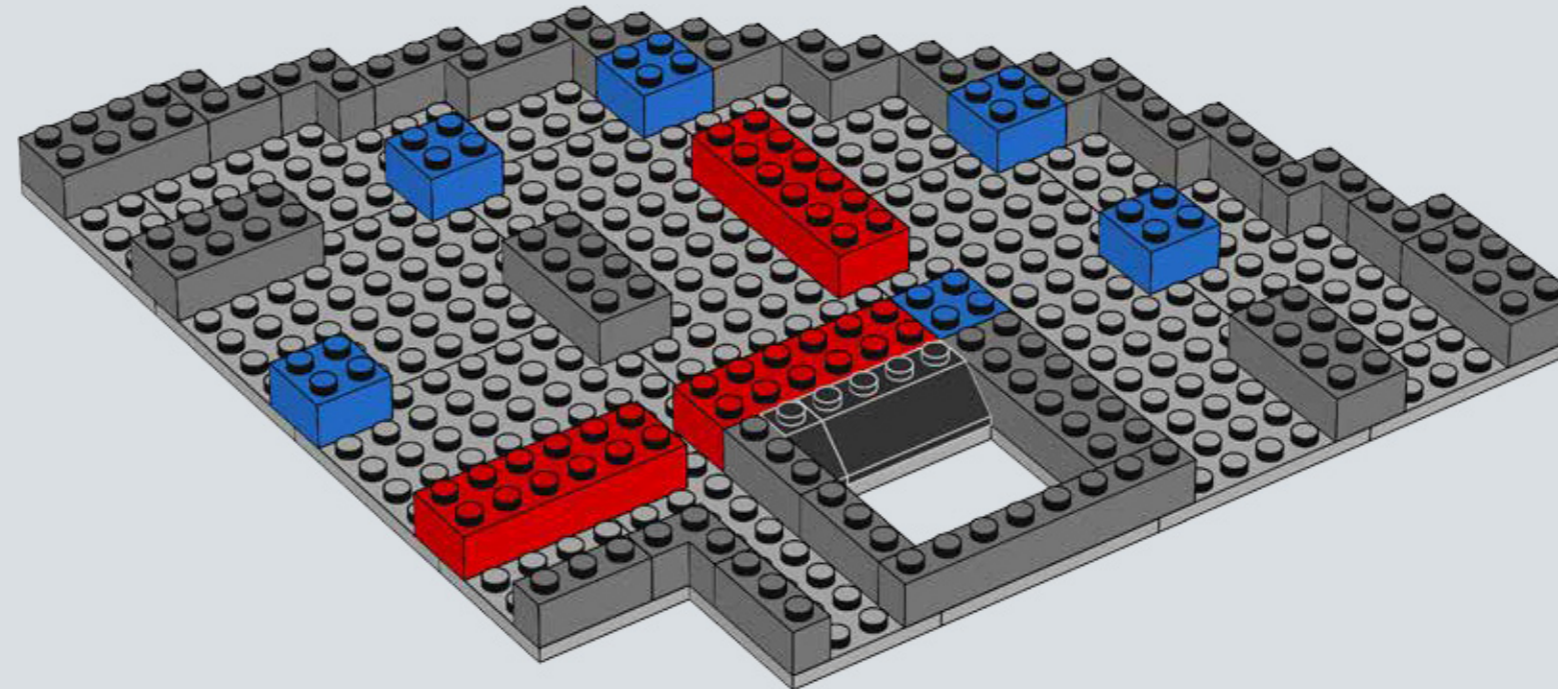

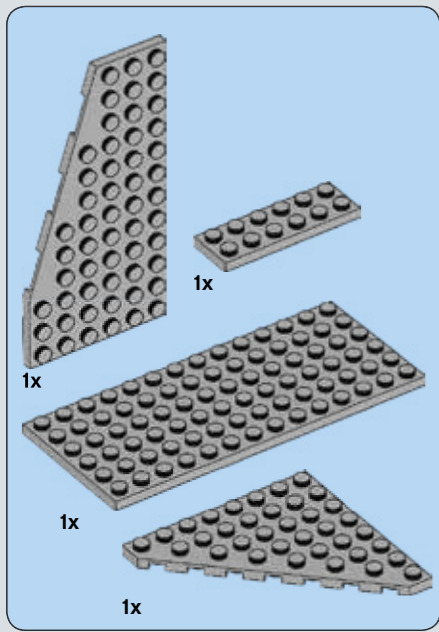

255

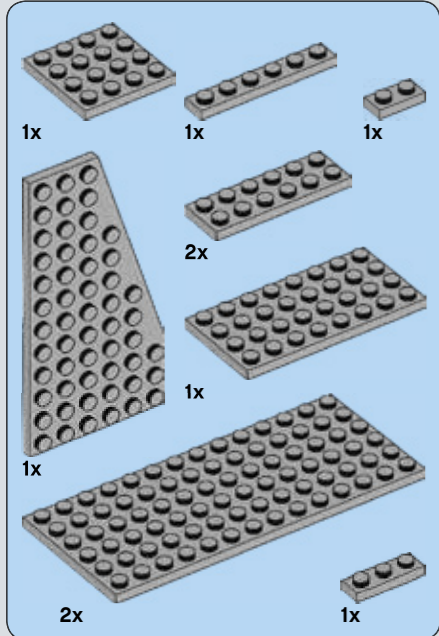
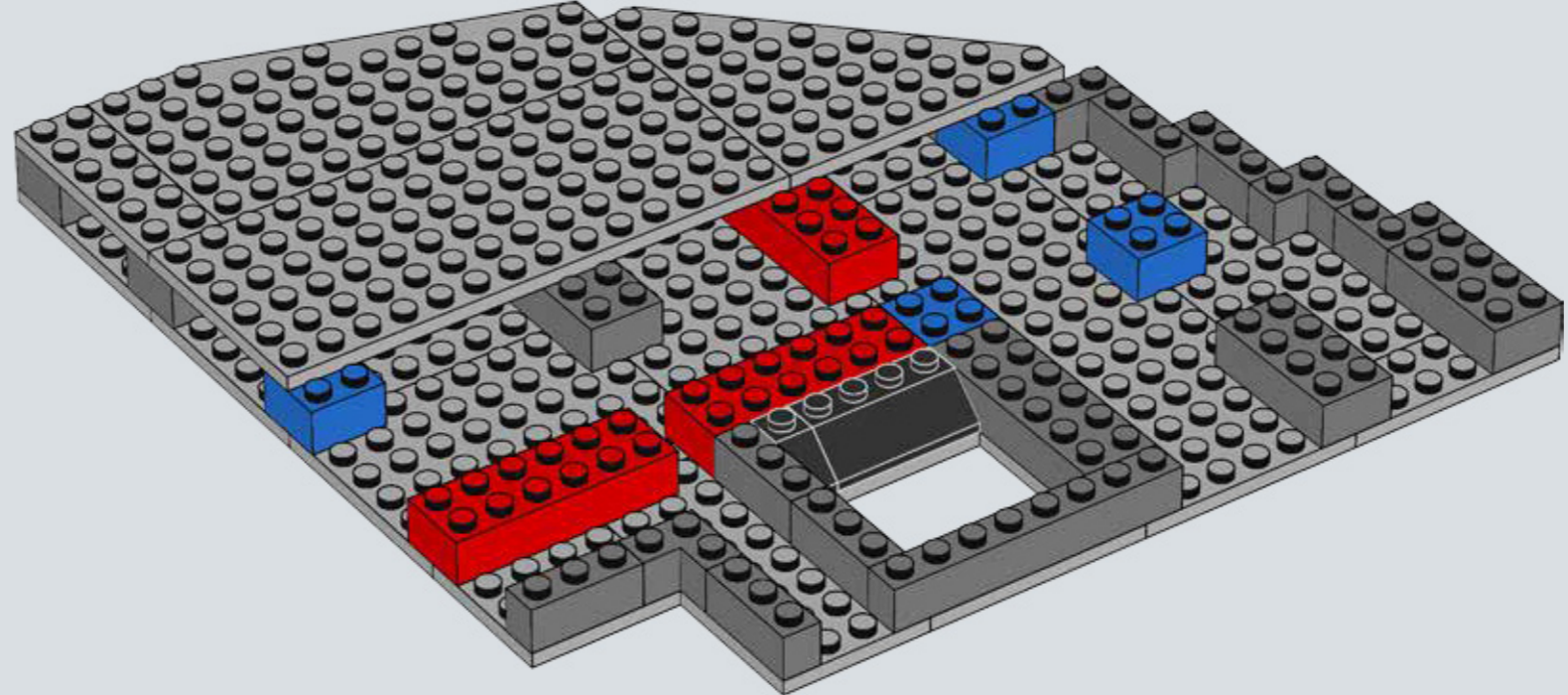

256

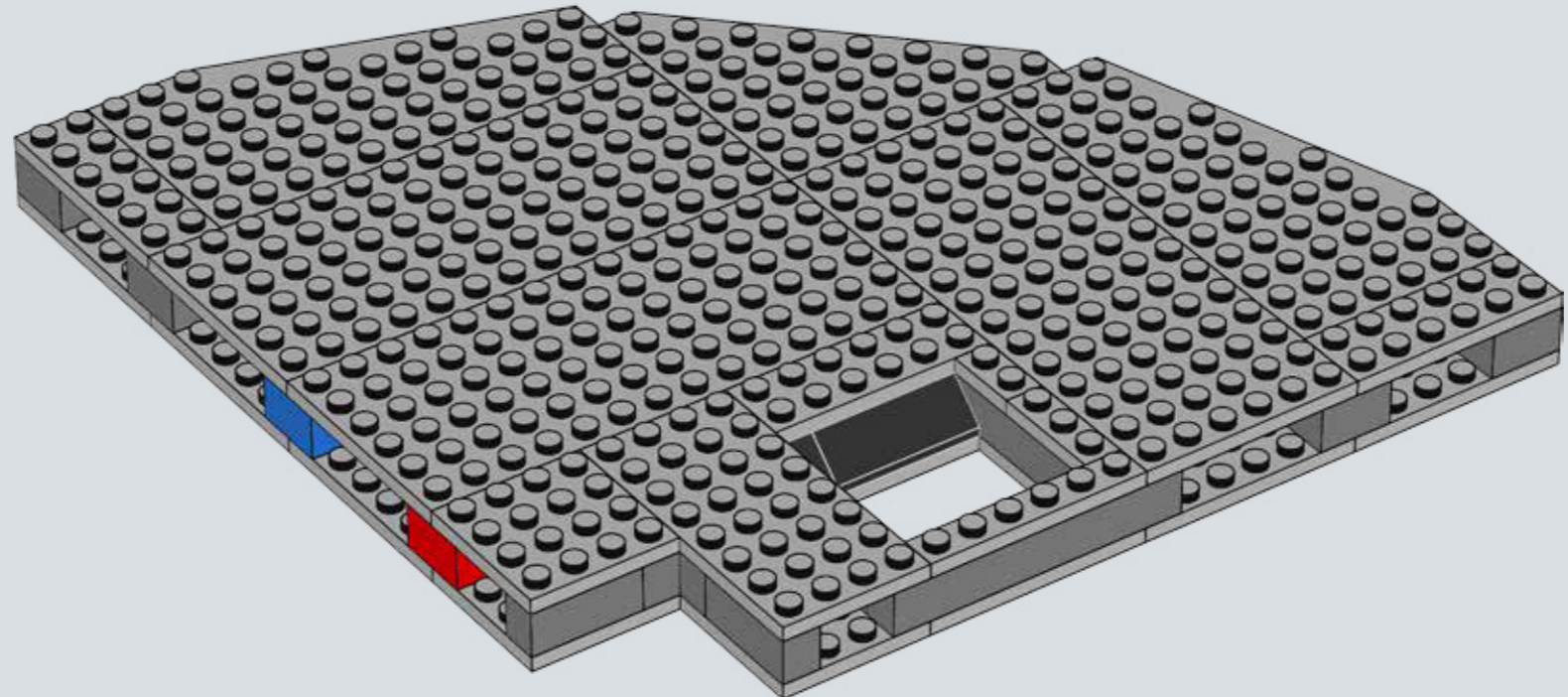



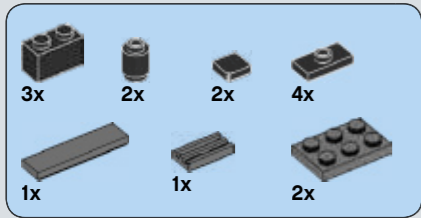

257

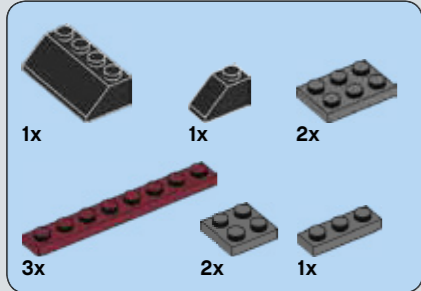
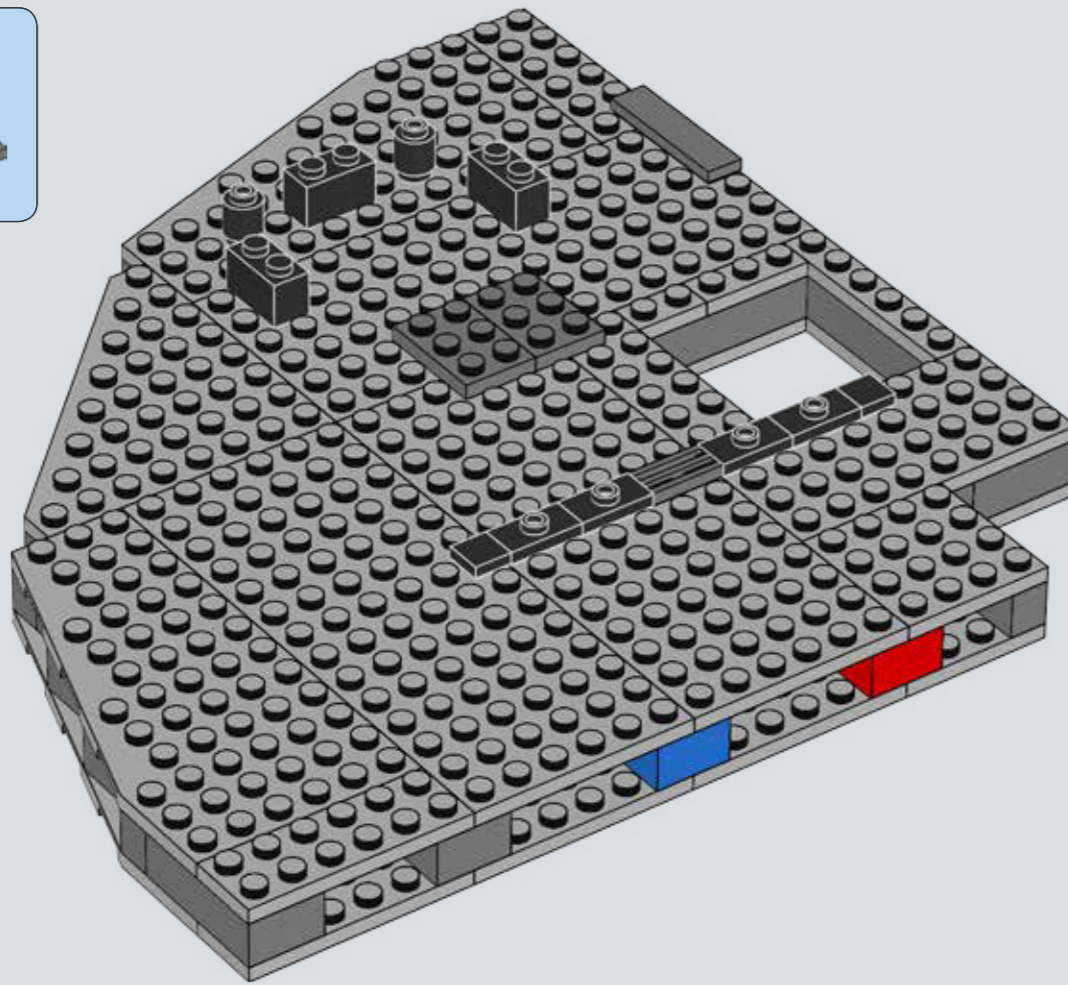
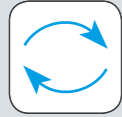

258

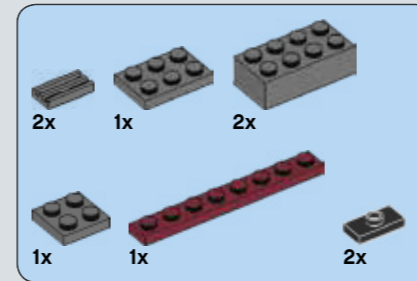
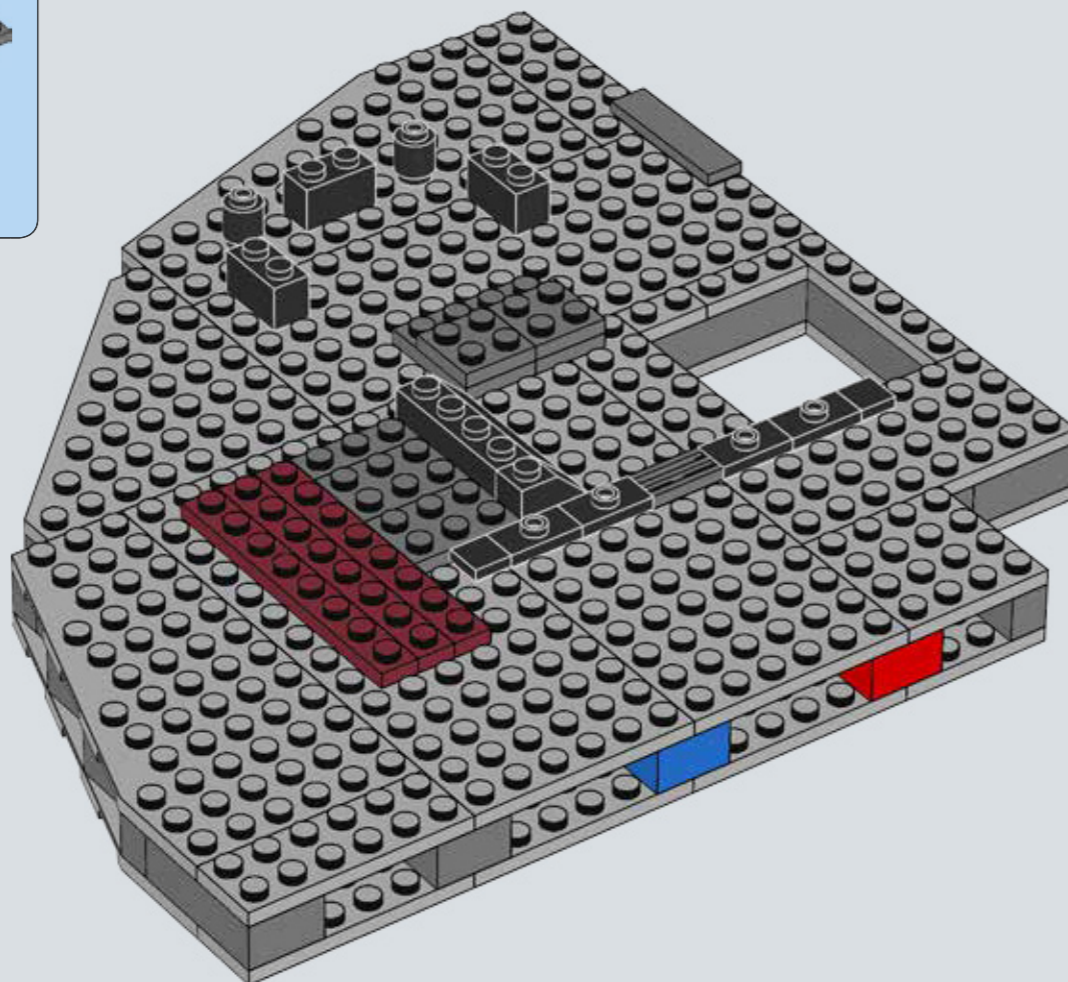

259

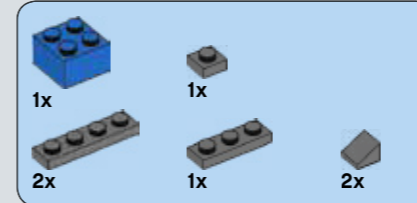
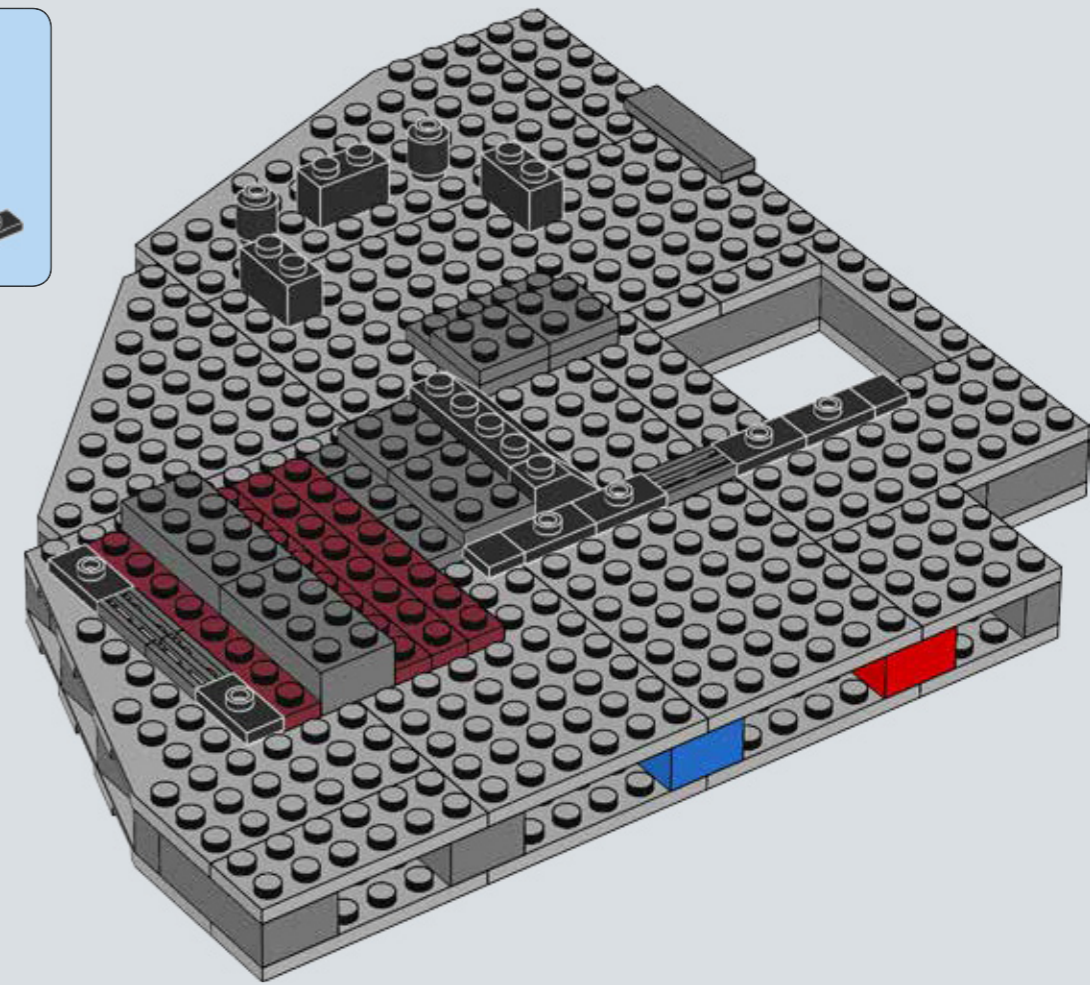

260

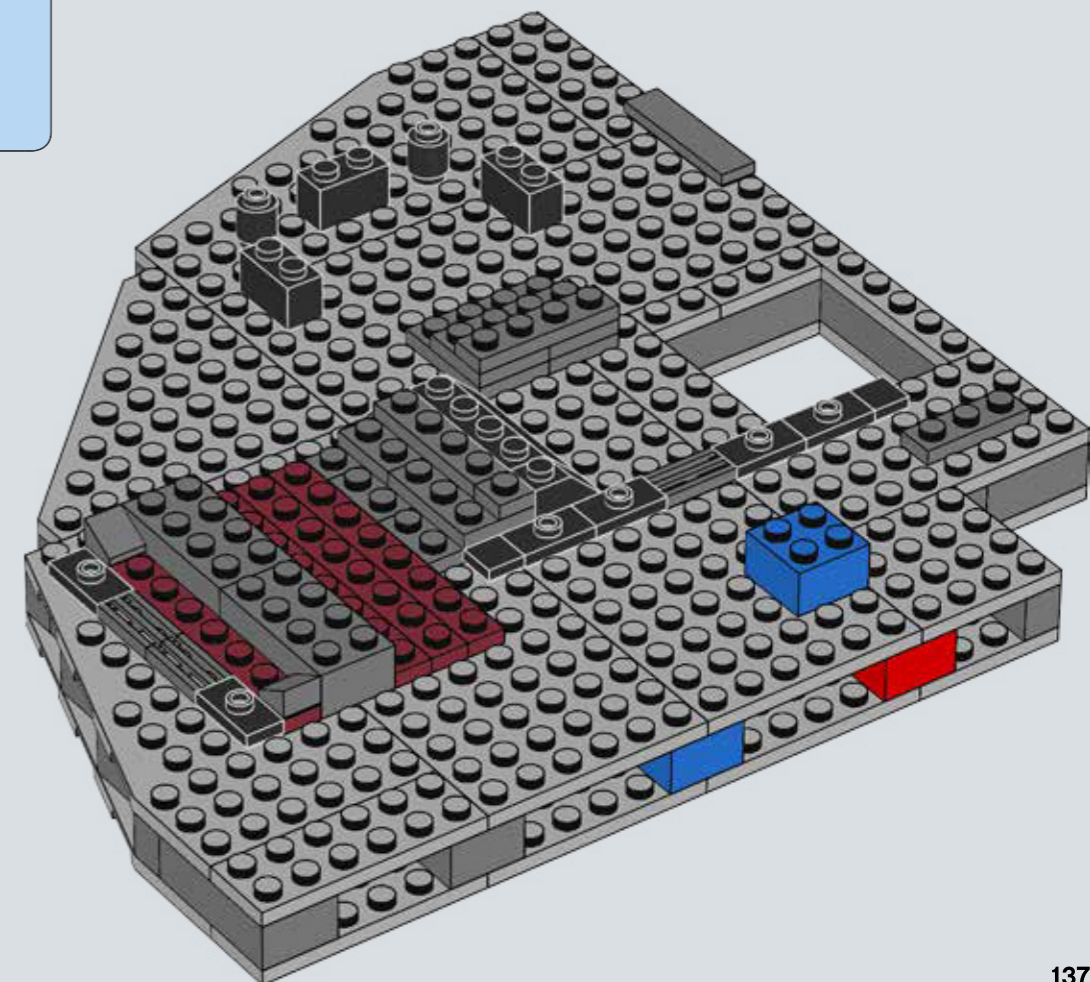



261

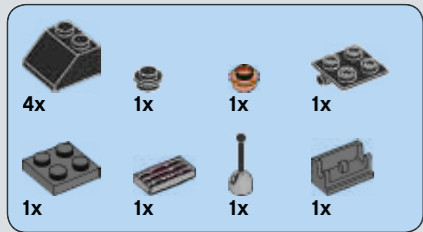
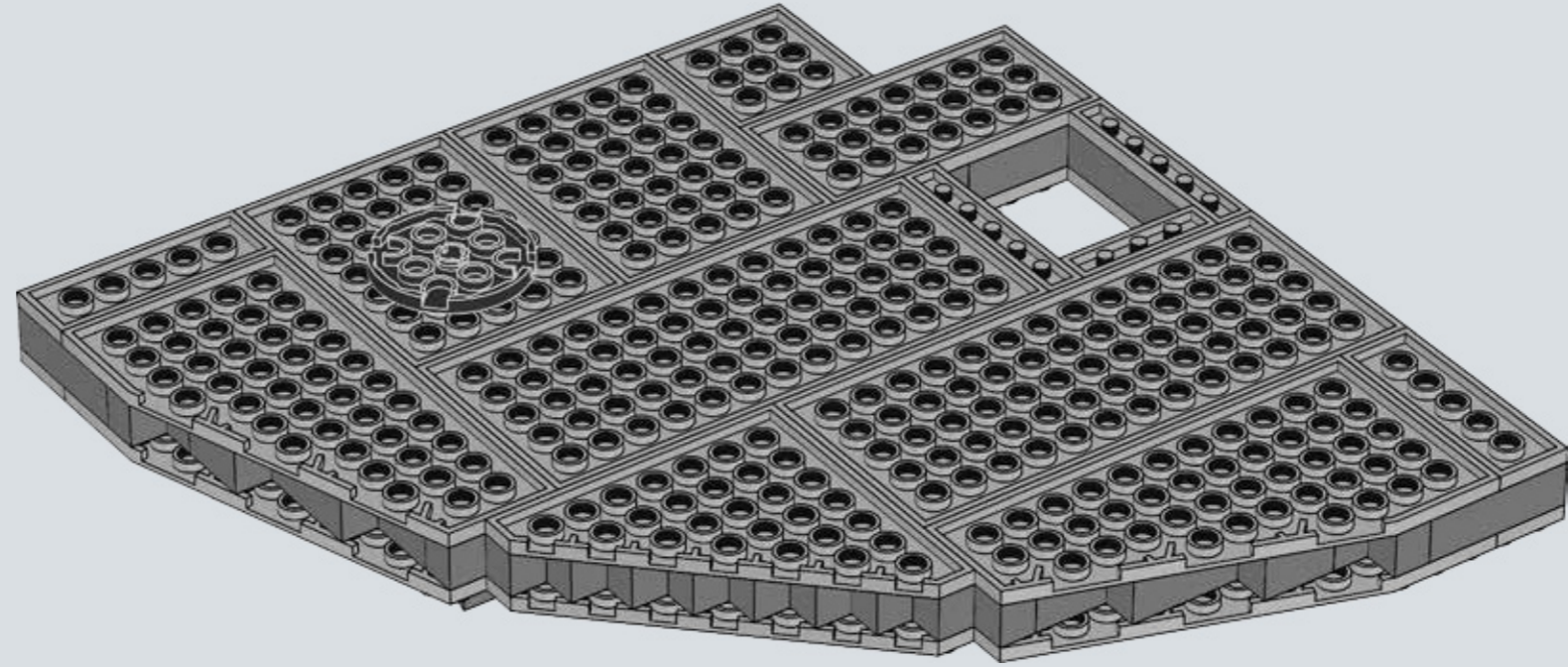

262

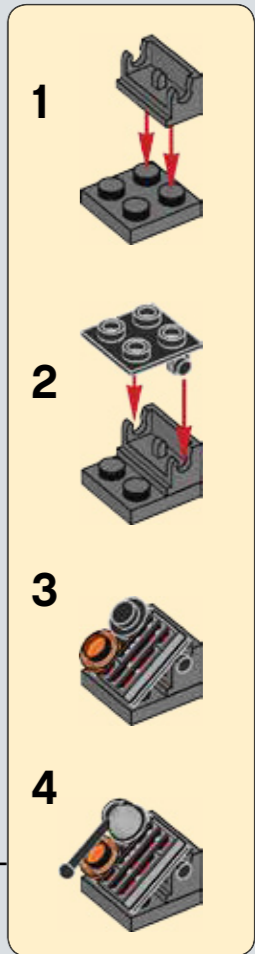
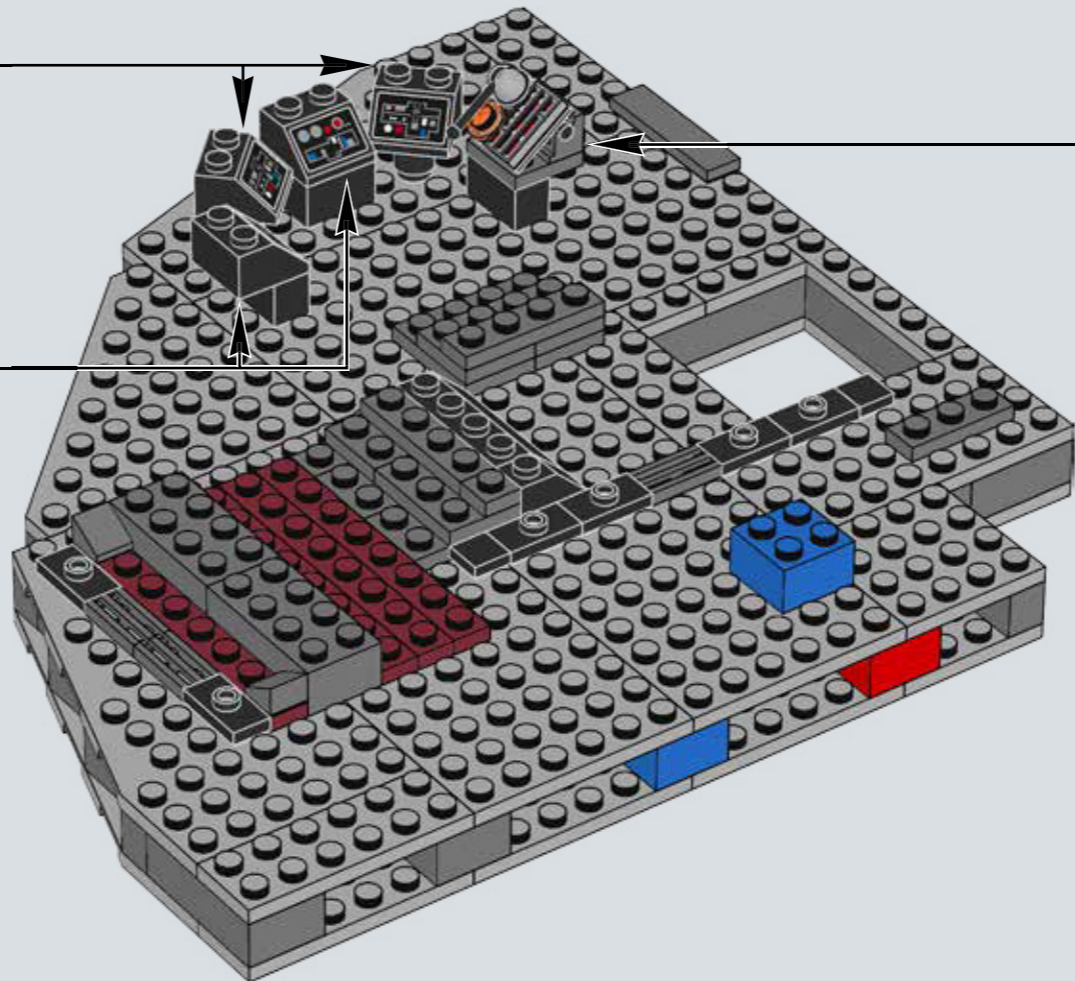
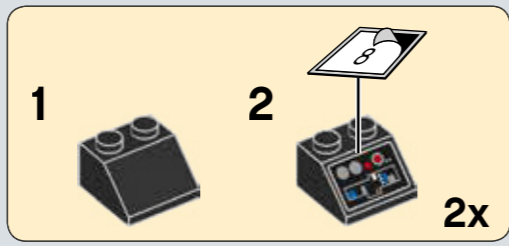
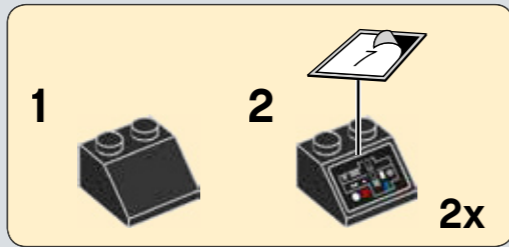

263

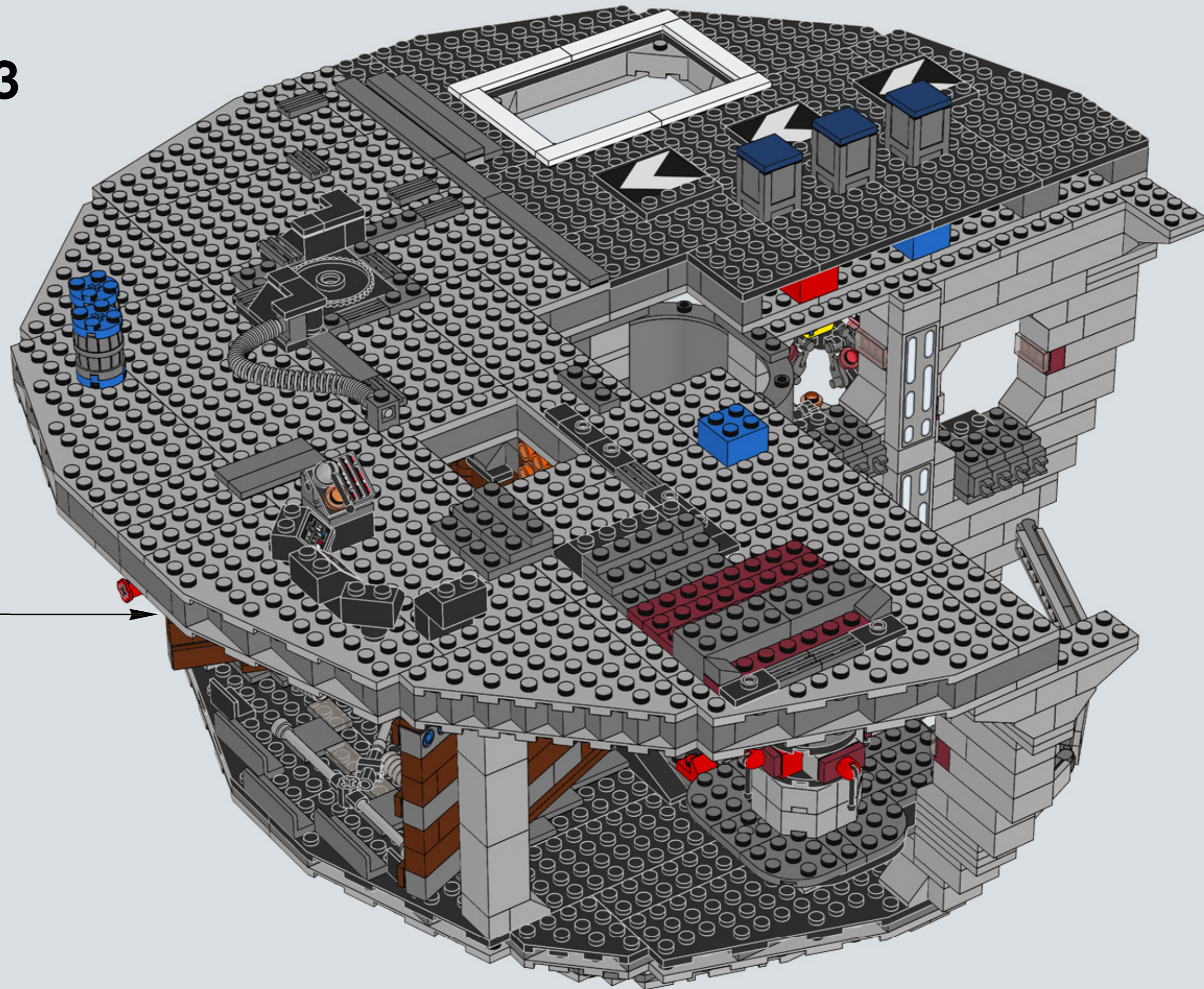

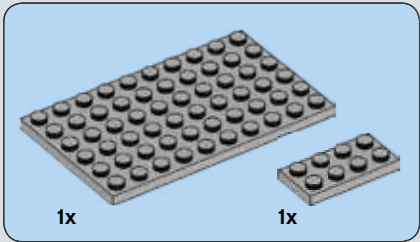
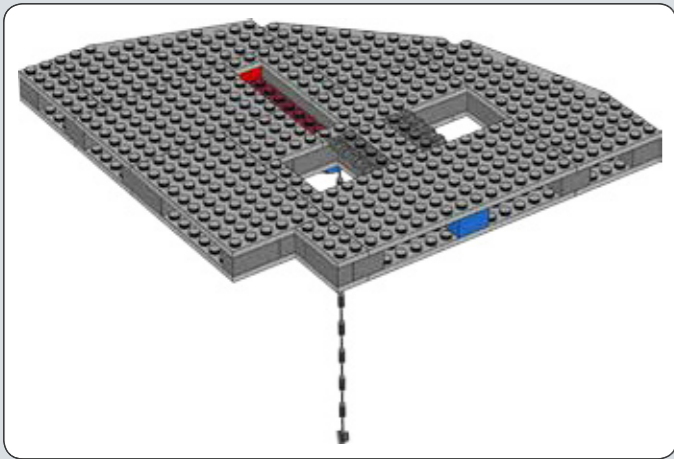

264

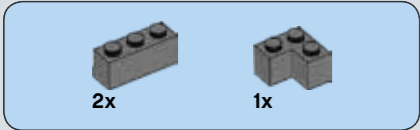
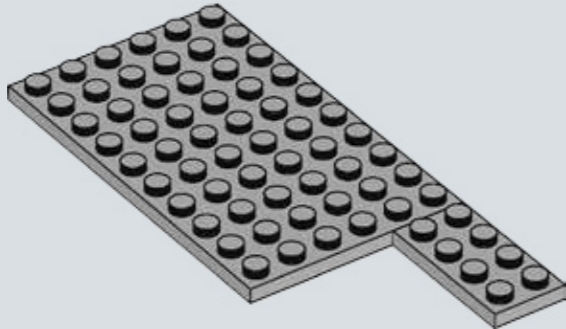

265

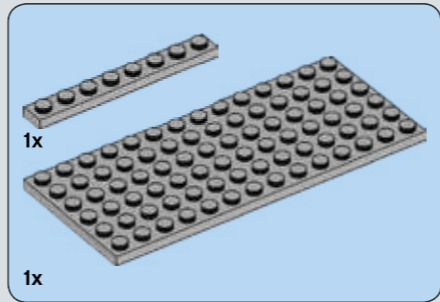
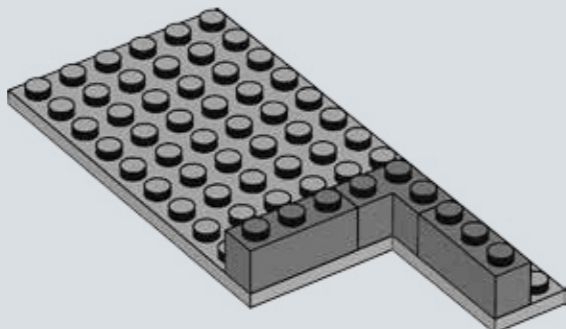

266

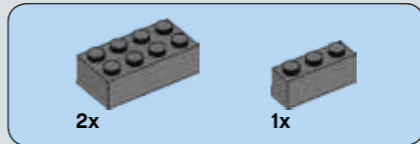
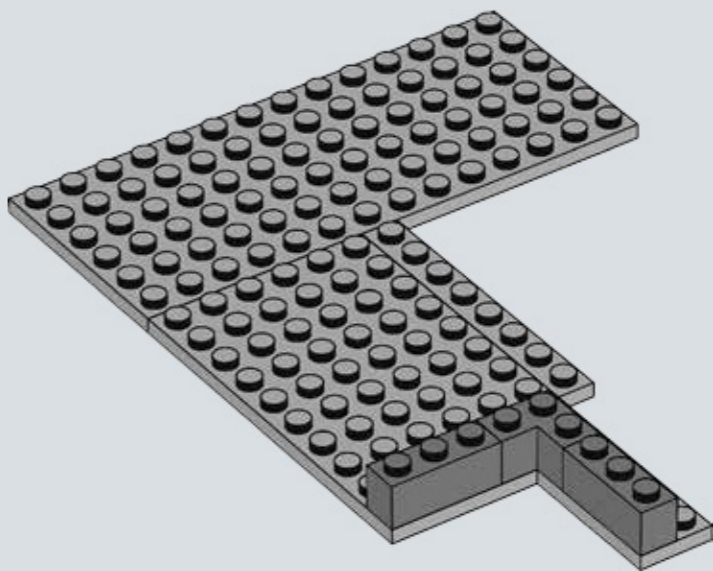

267

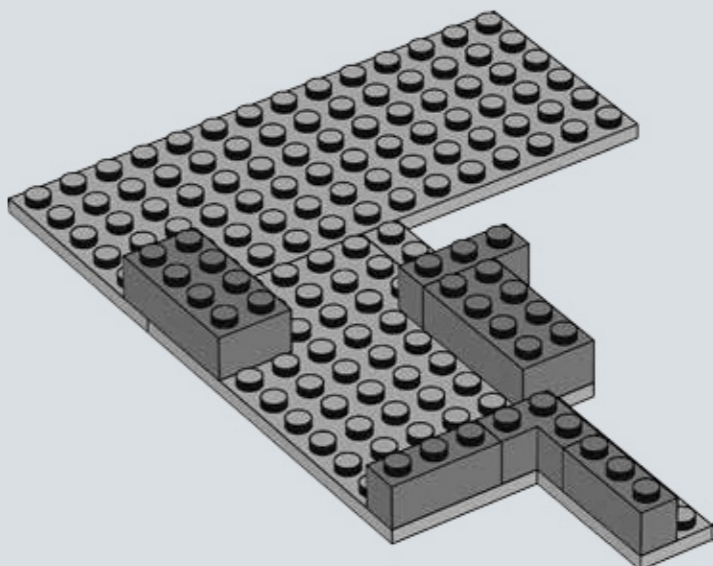

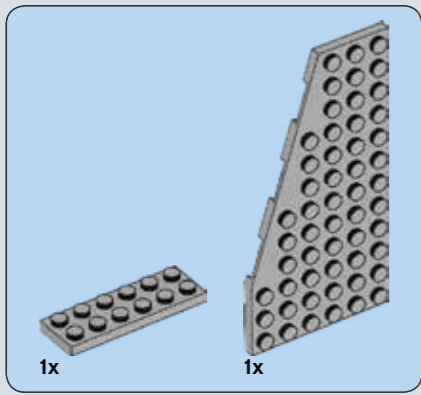

268

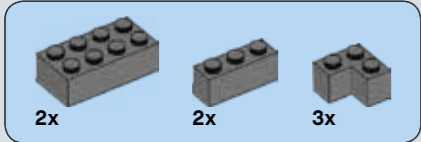
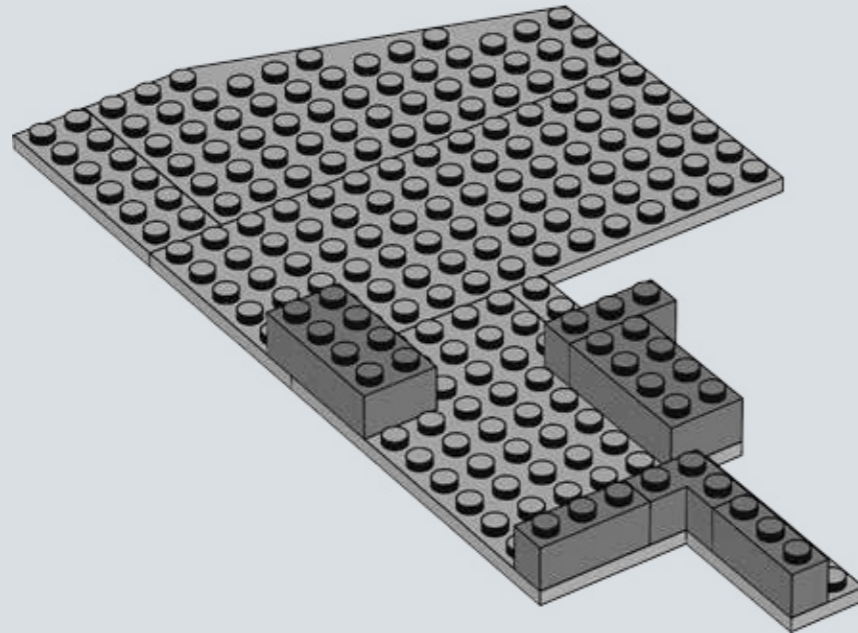

269

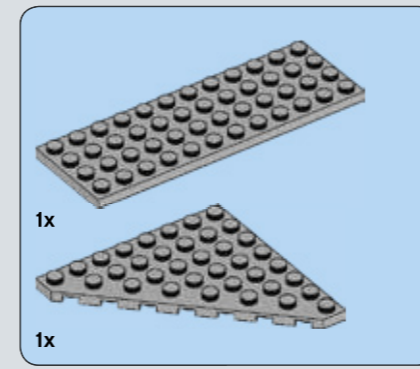
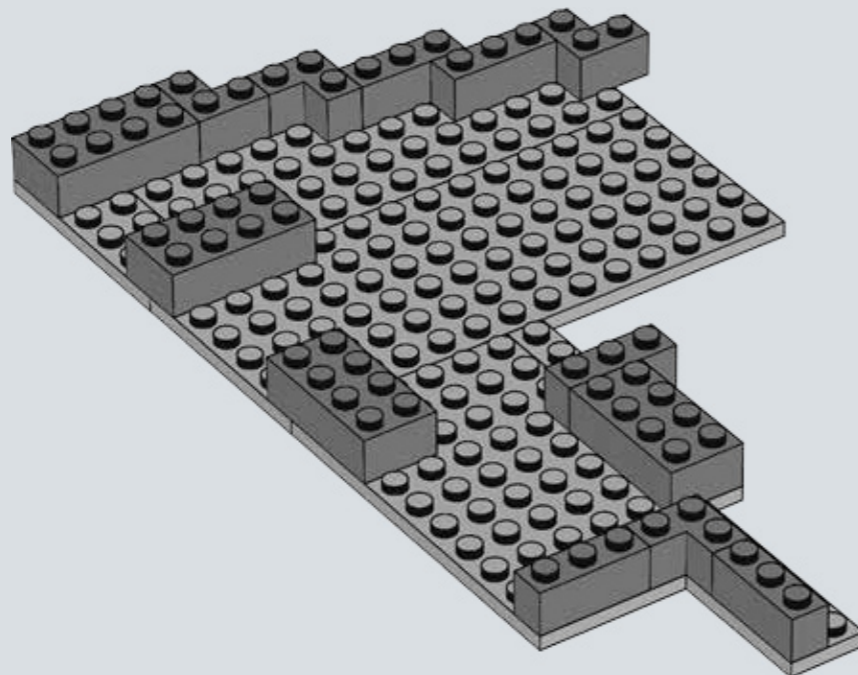

270

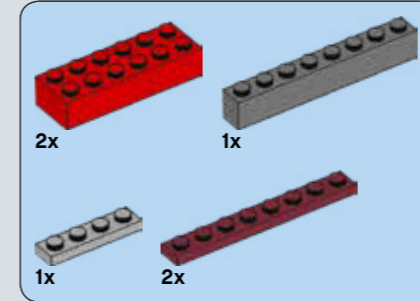
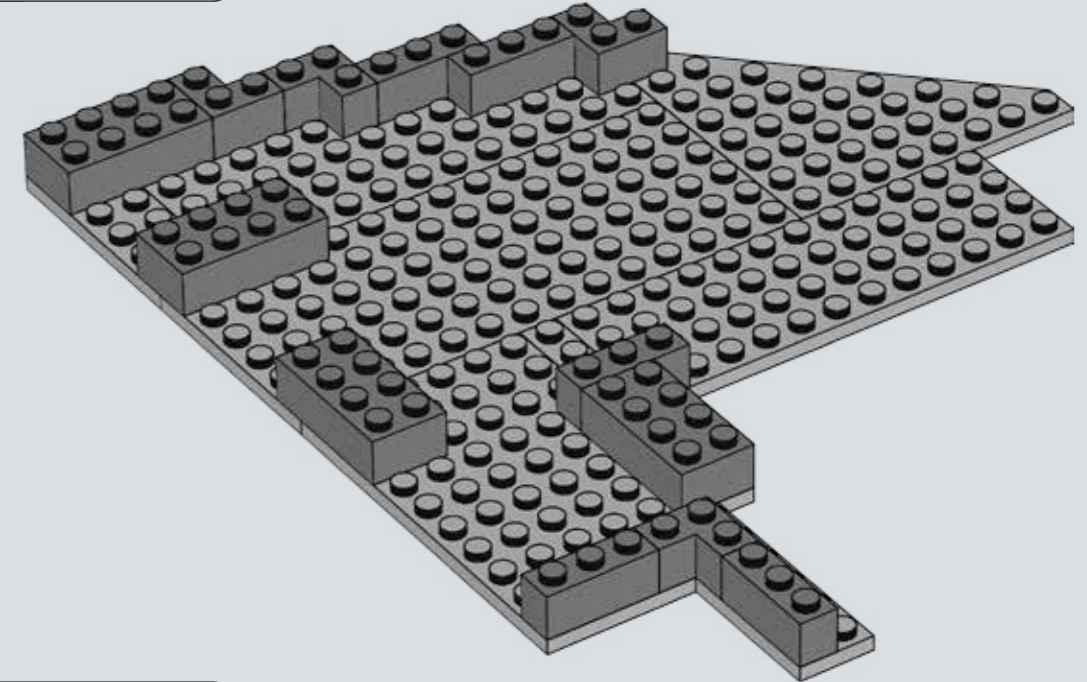

271

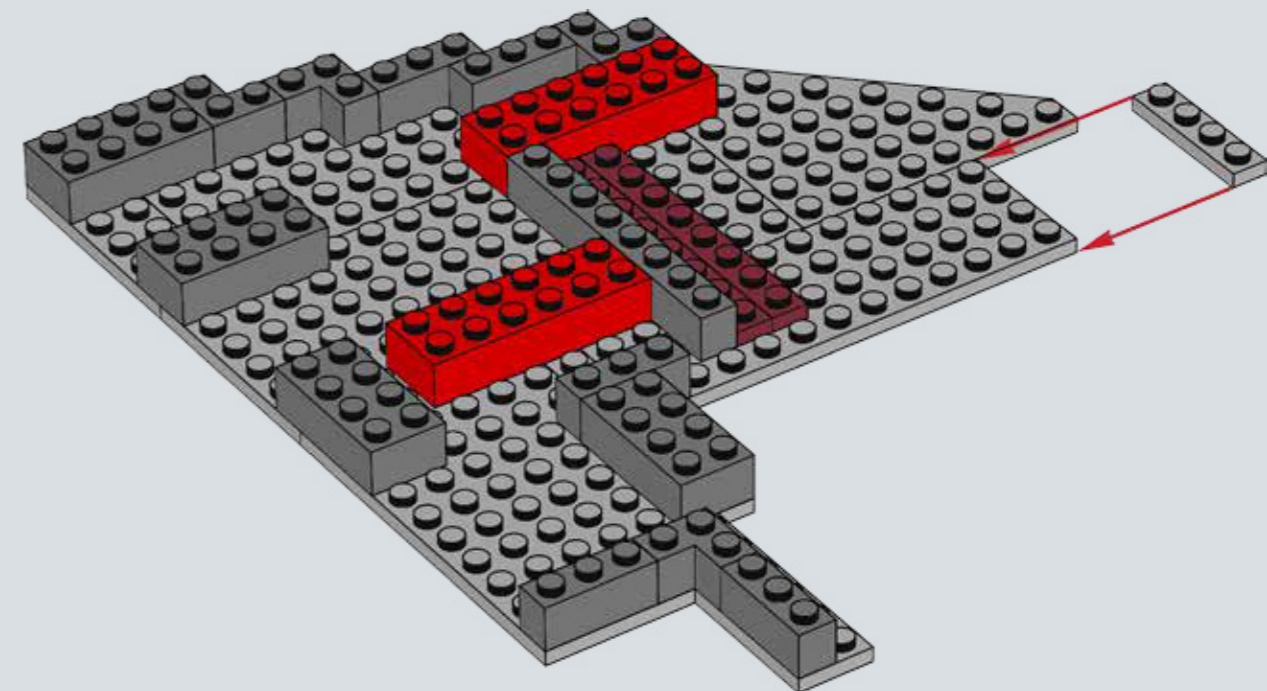

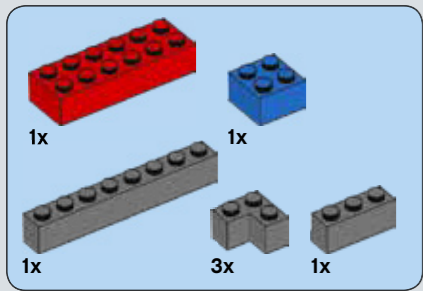

272

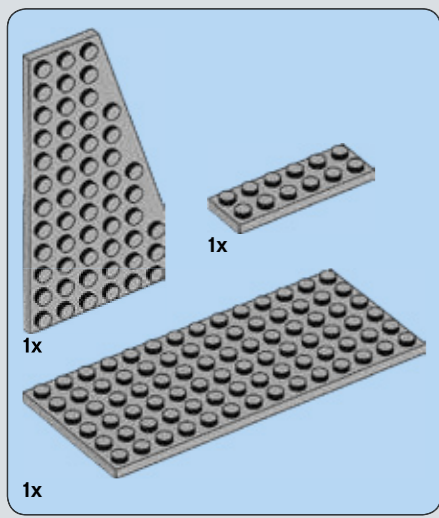
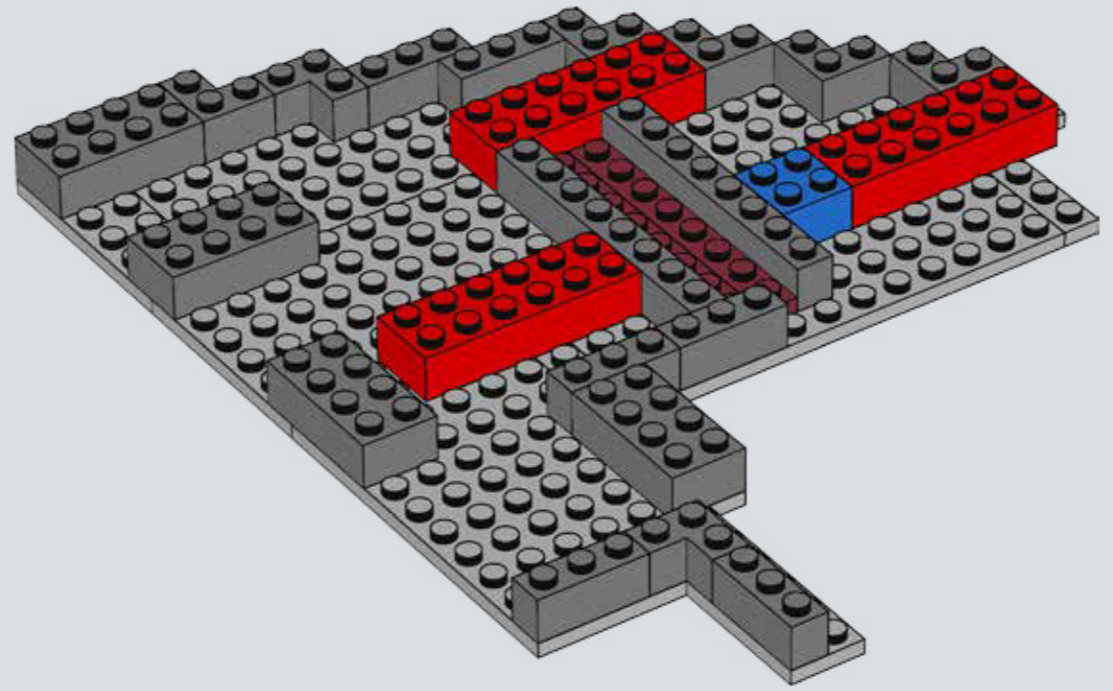

273

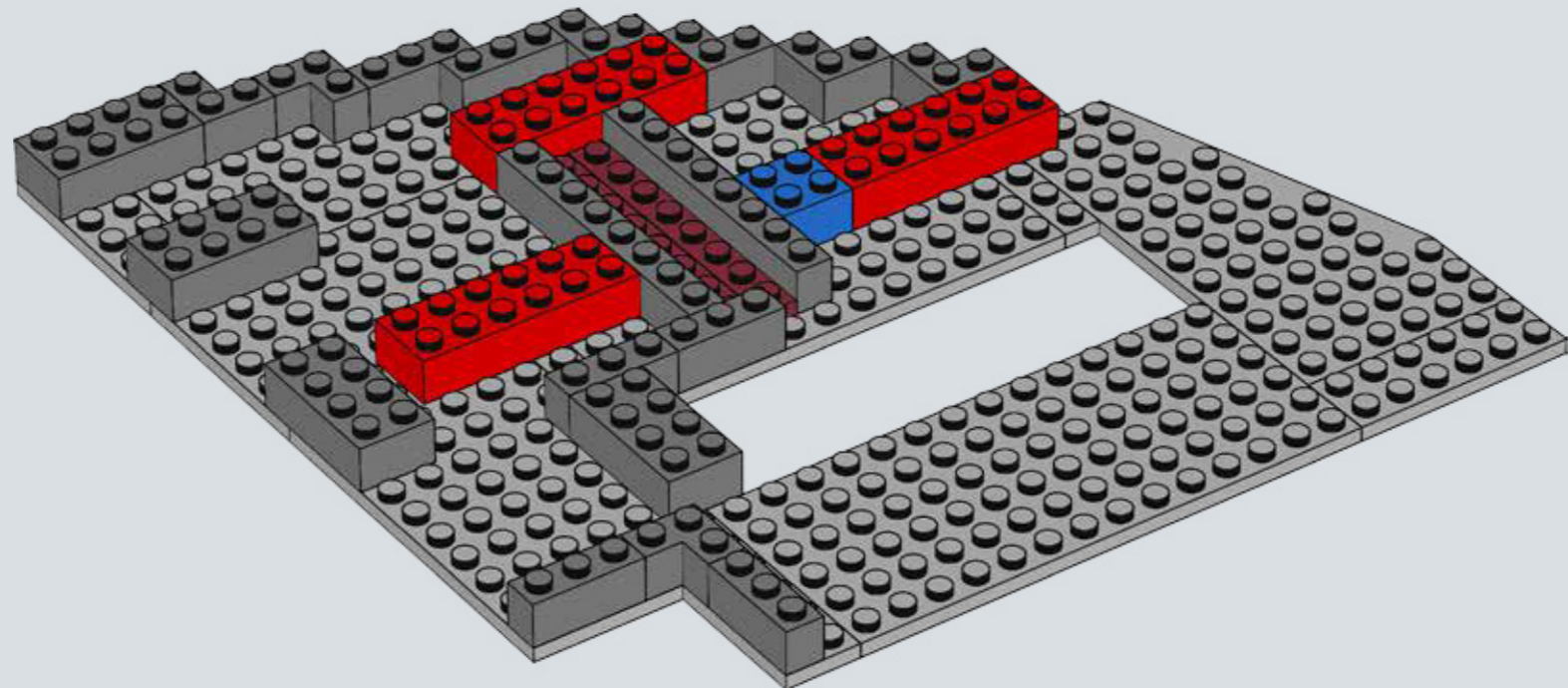

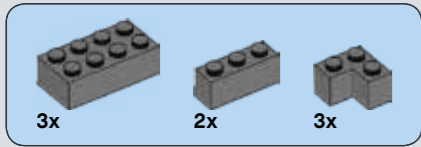

274

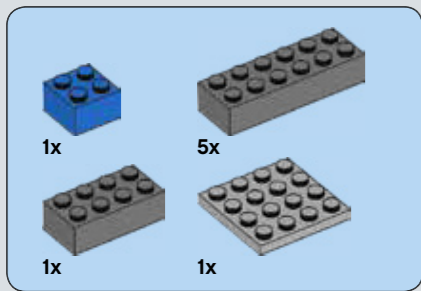
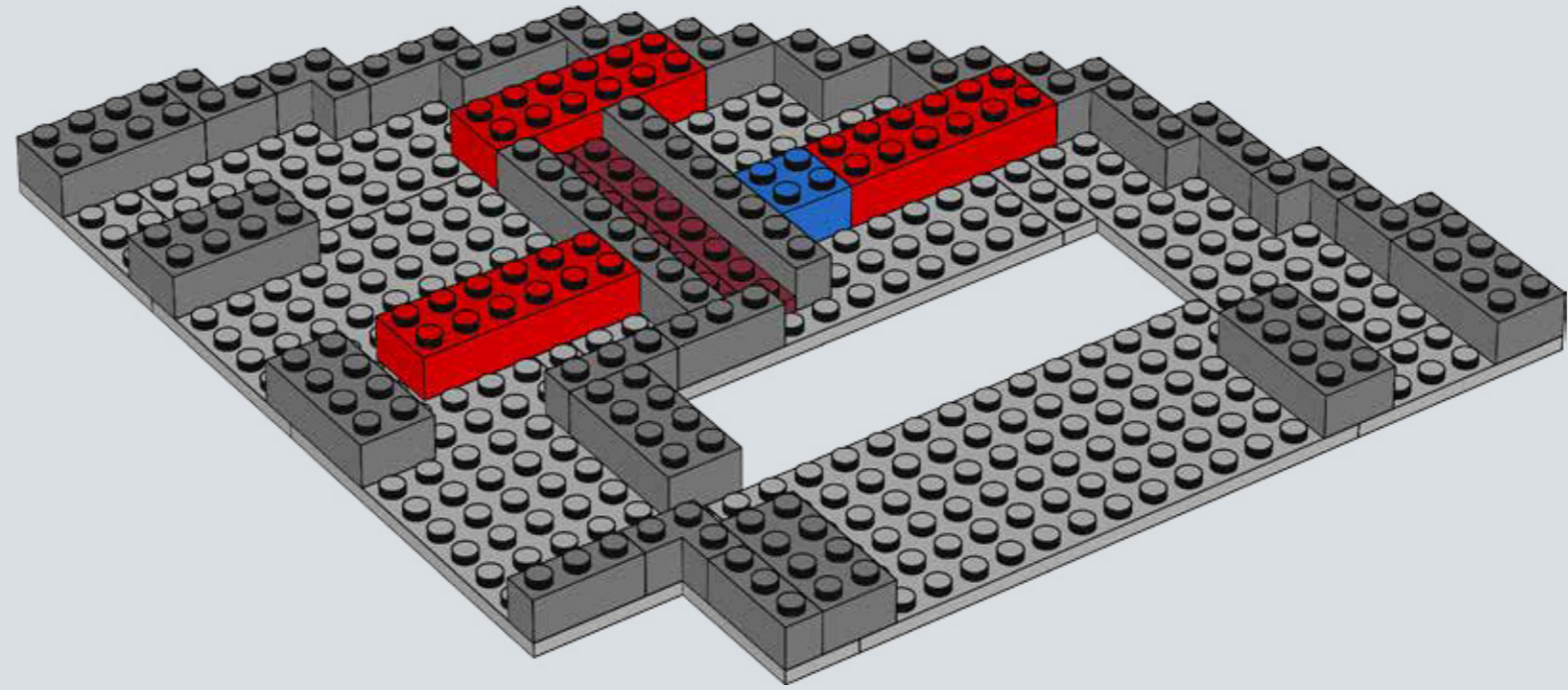

275

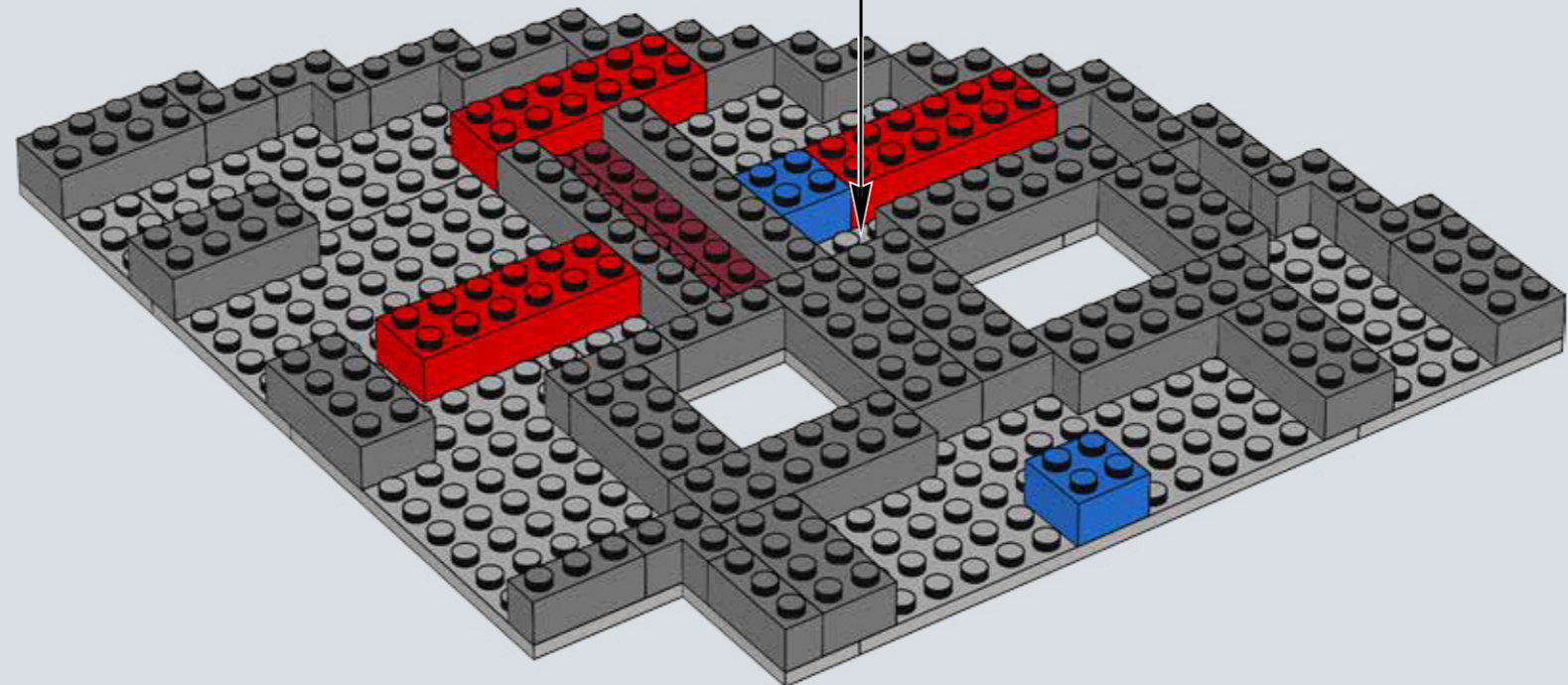
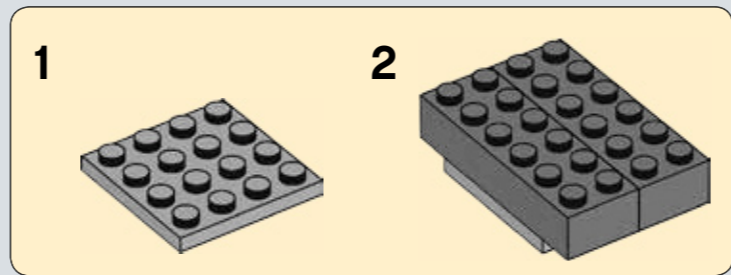

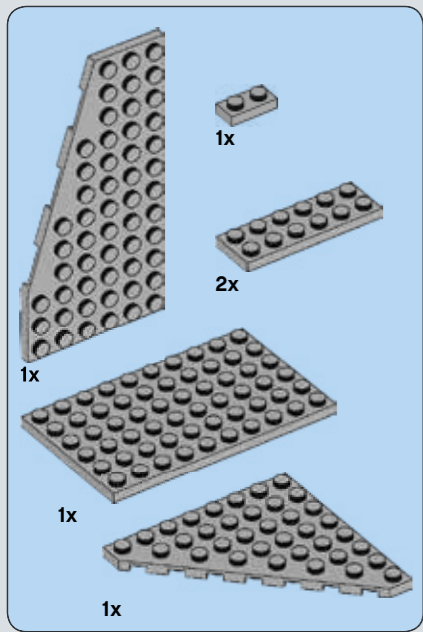

**276**

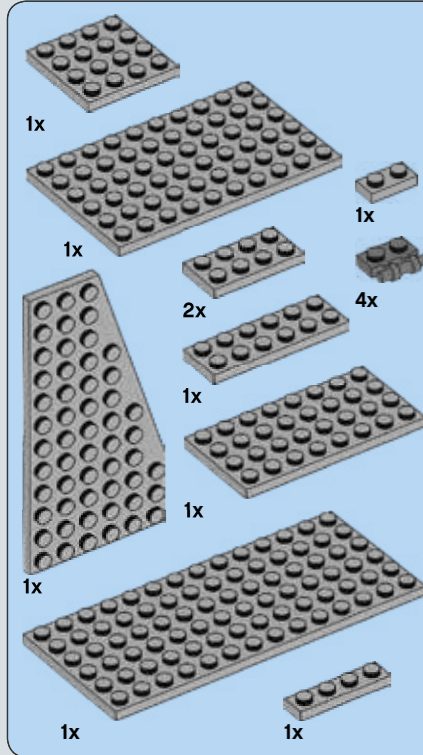
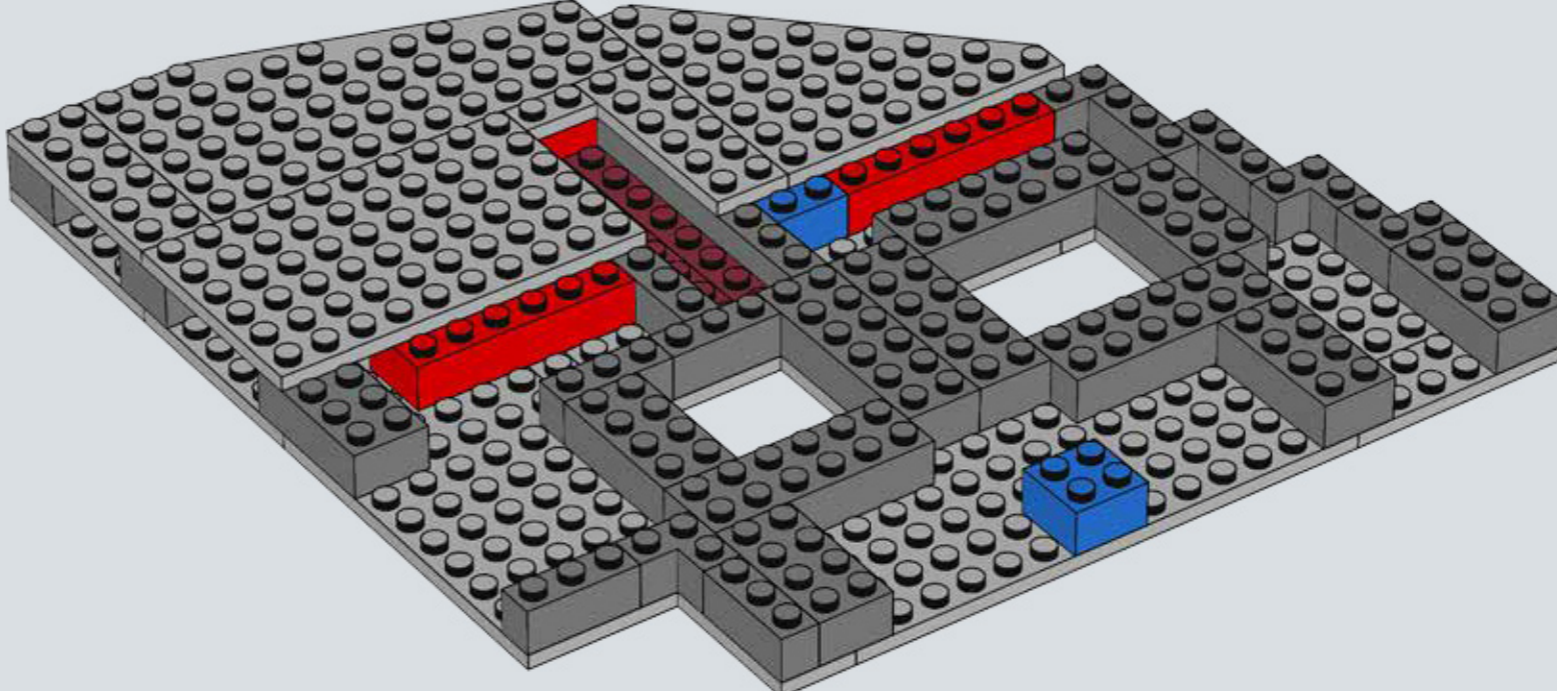

**277**

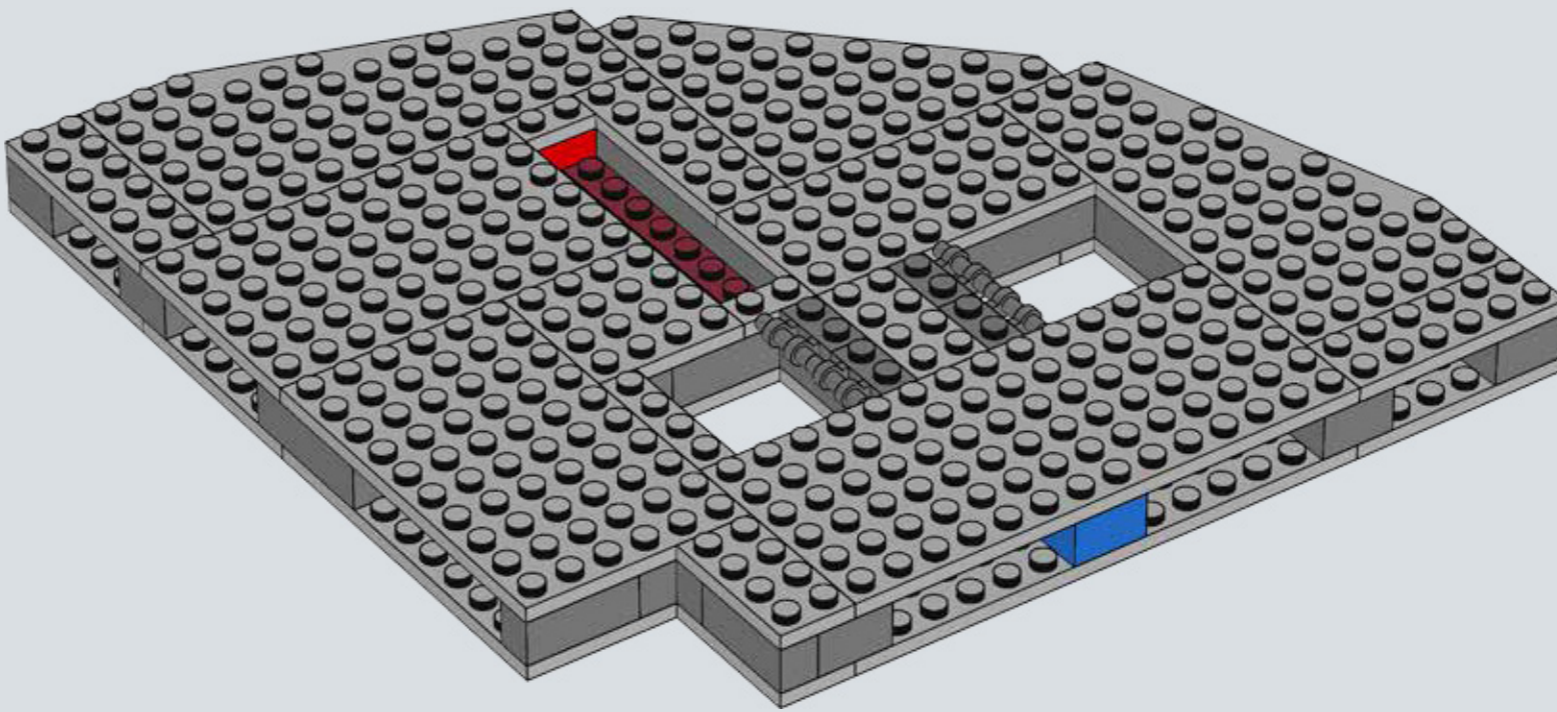





278

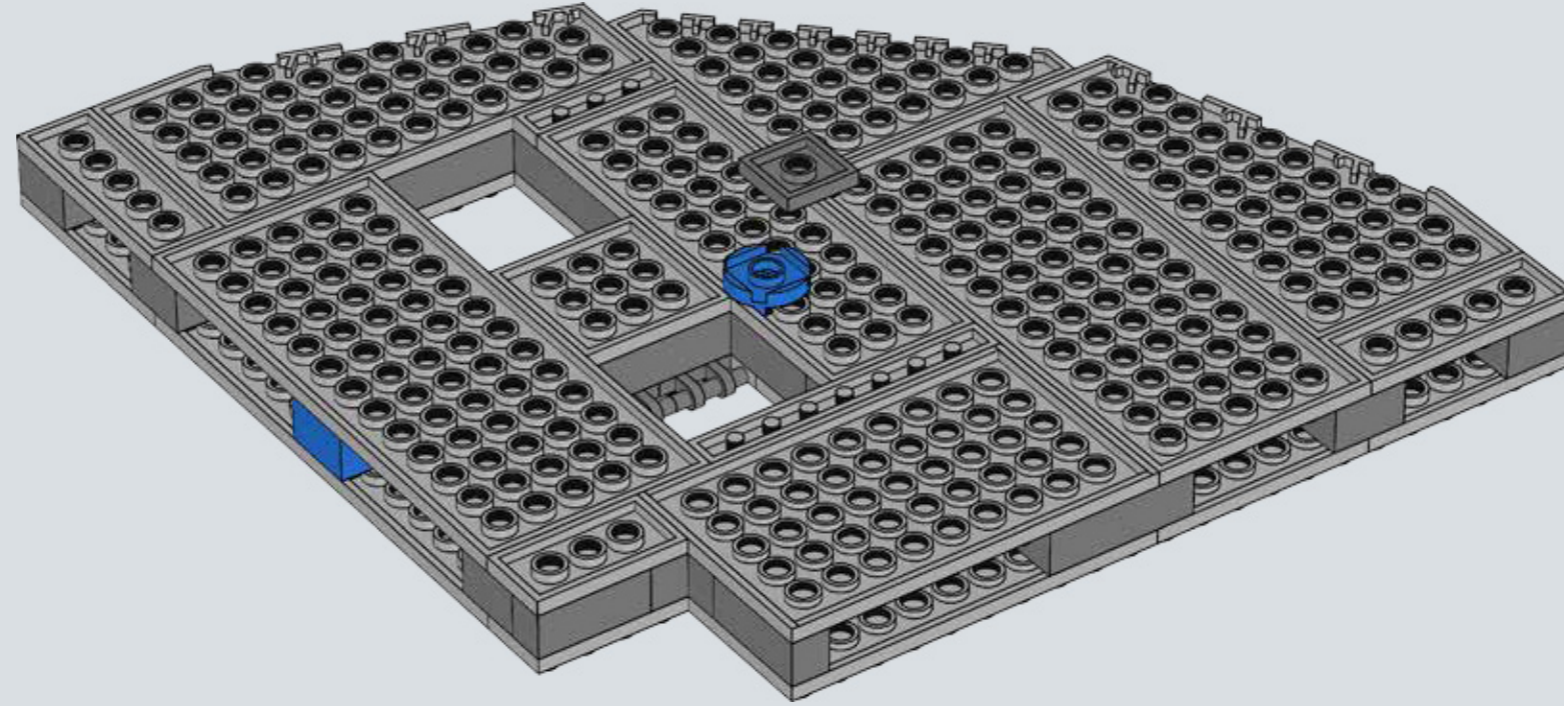

279

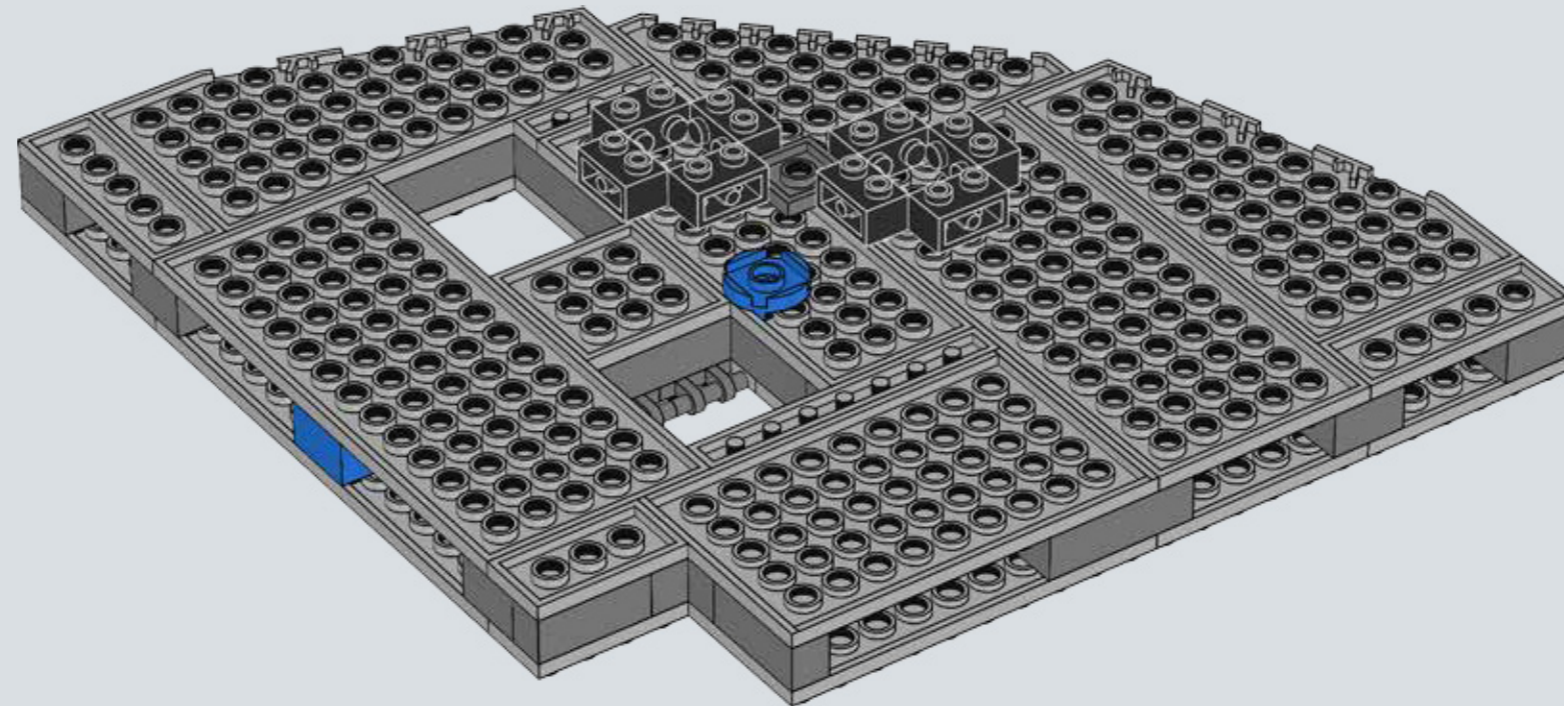

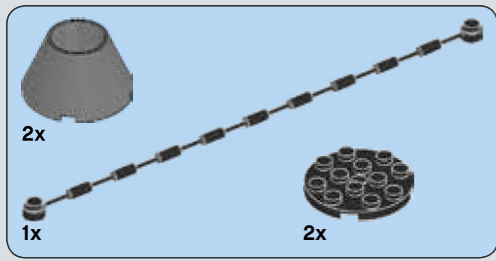

280

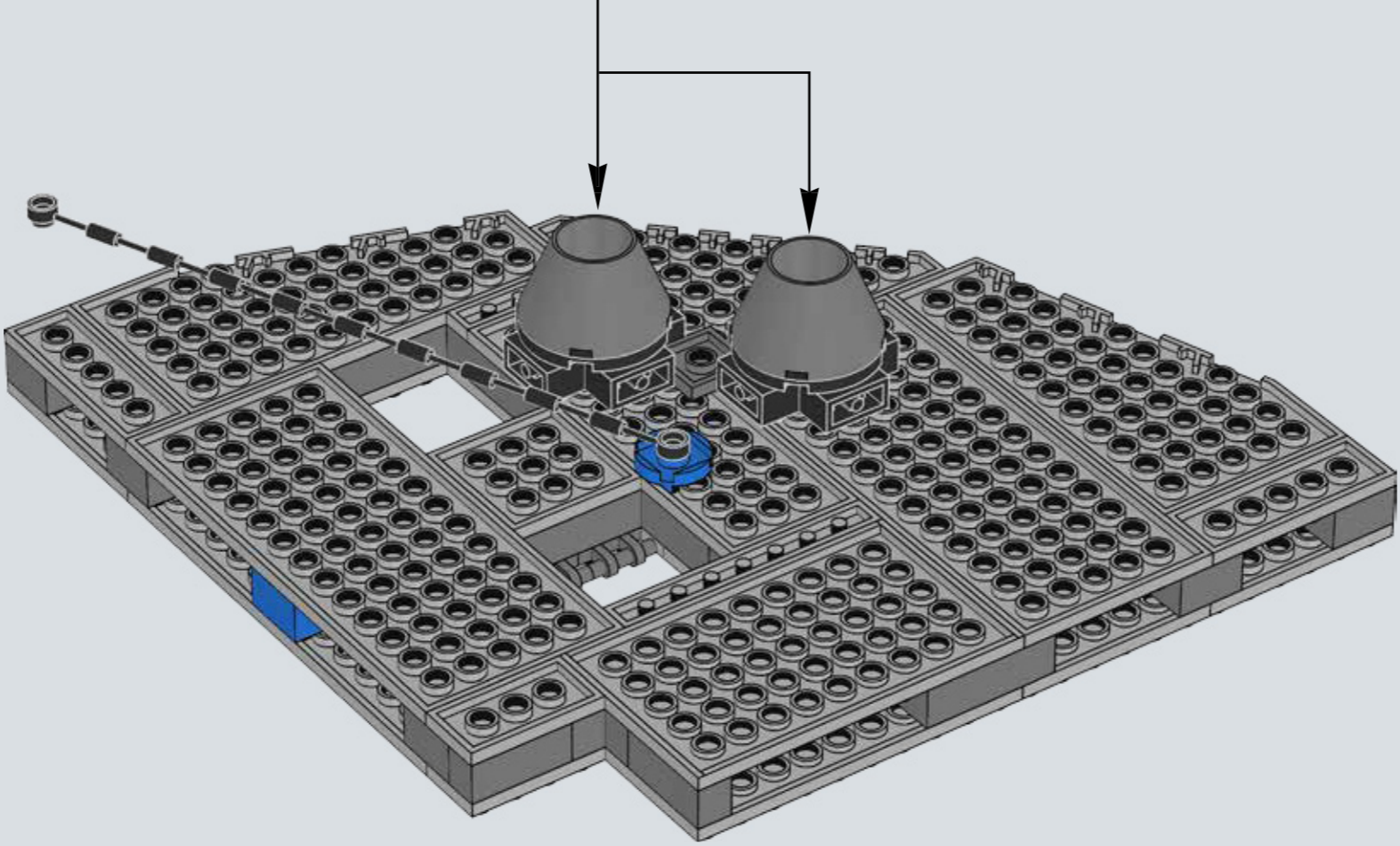
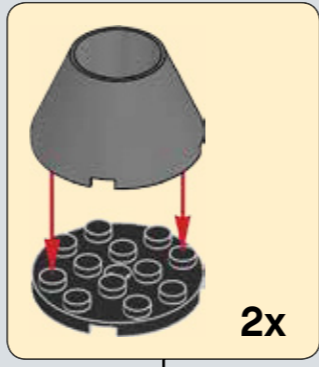

281

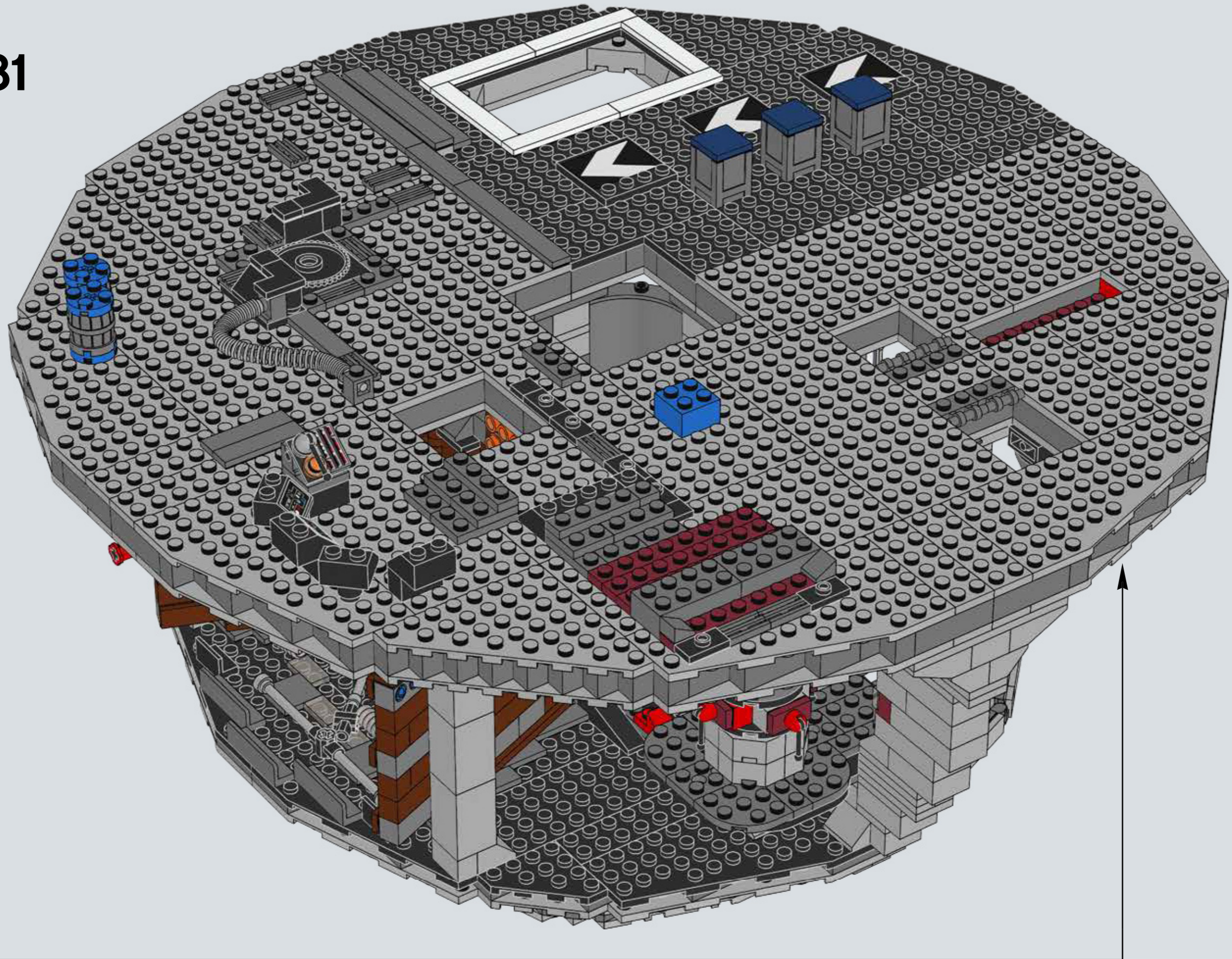

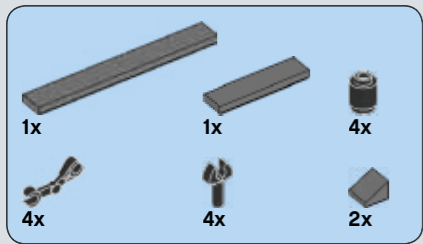

282

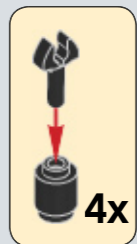
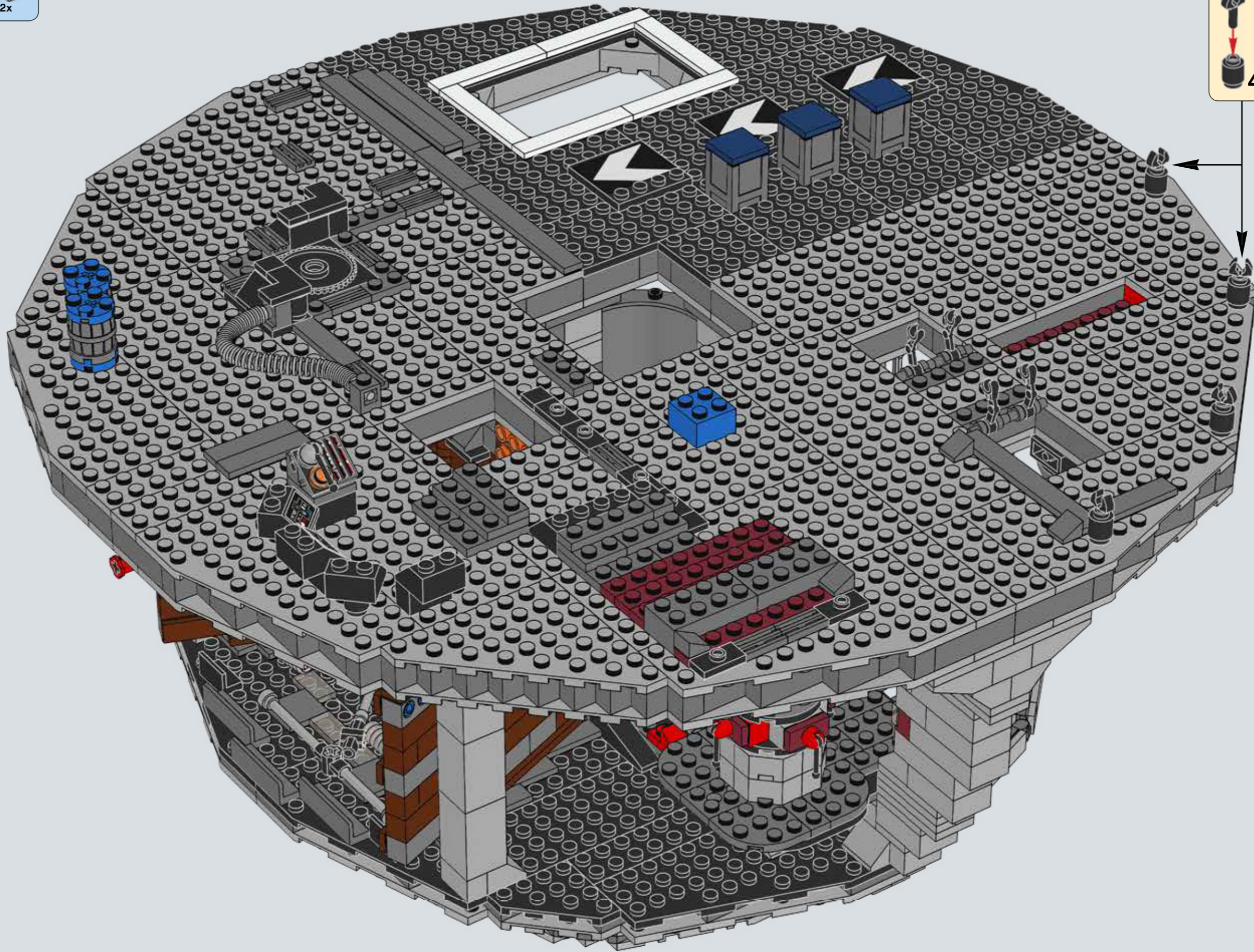

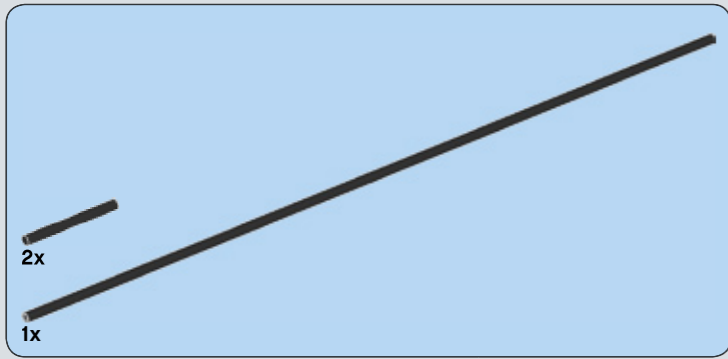

283

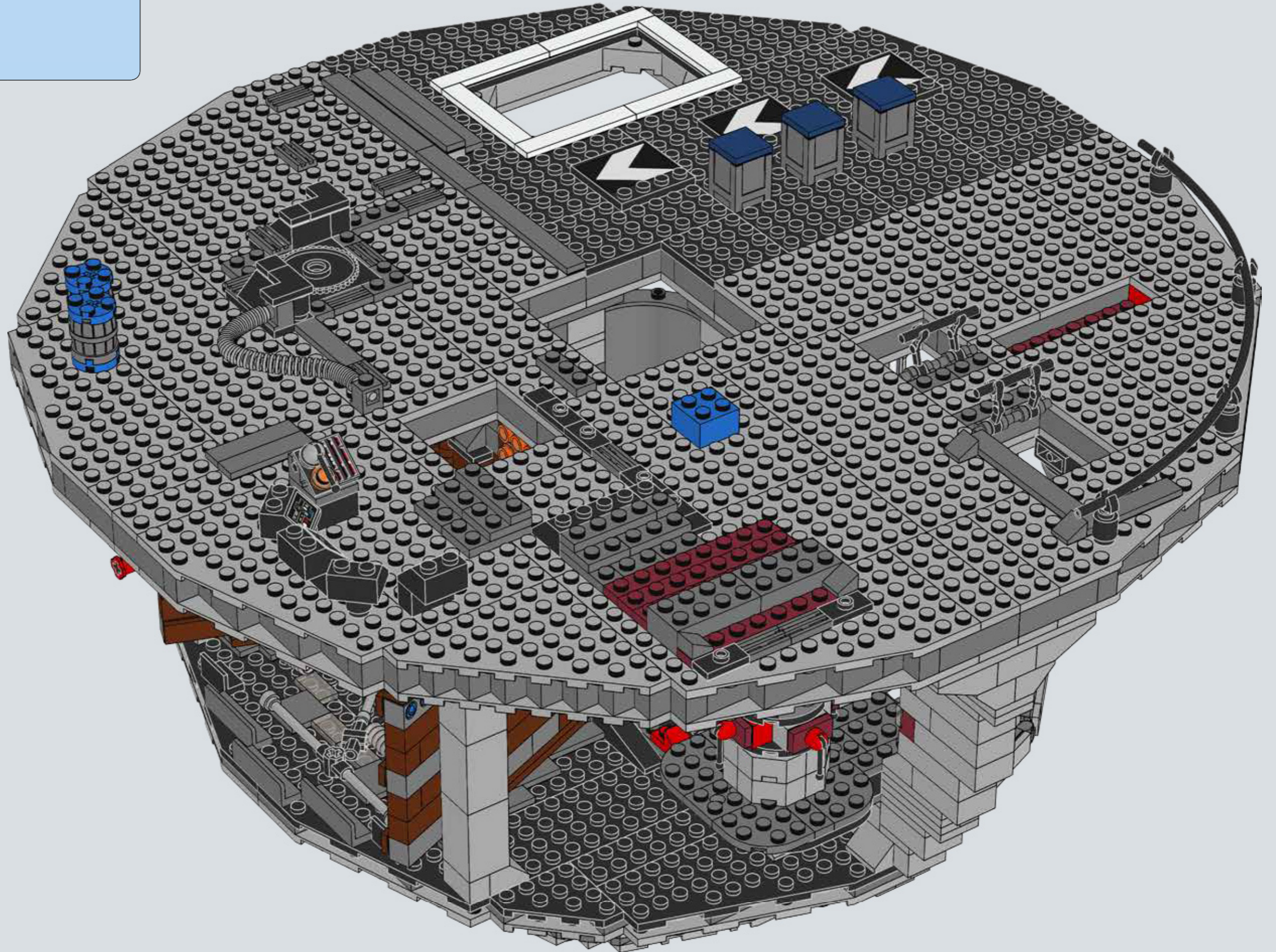

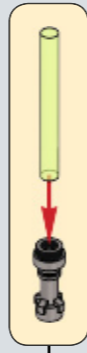
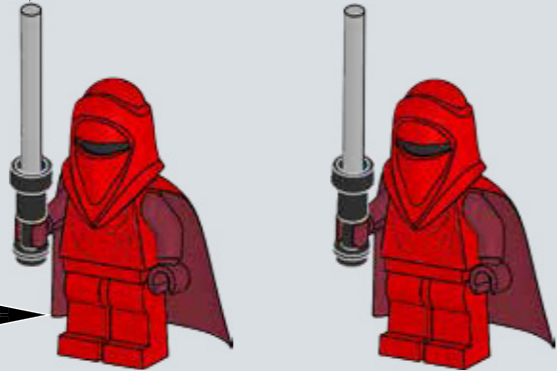
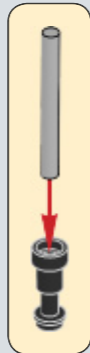
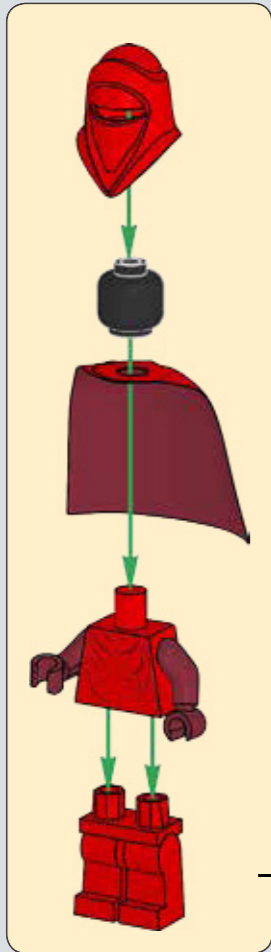
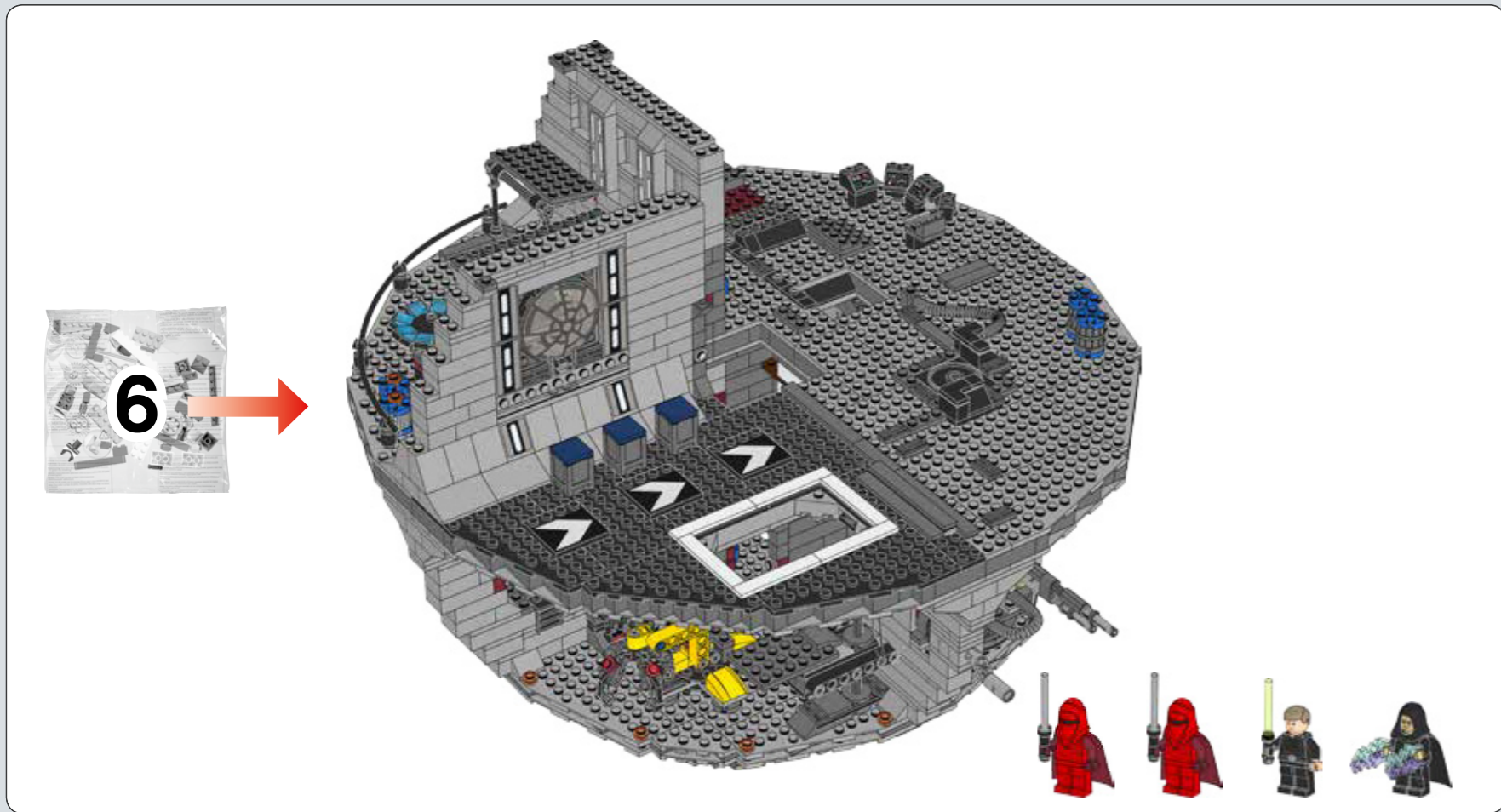

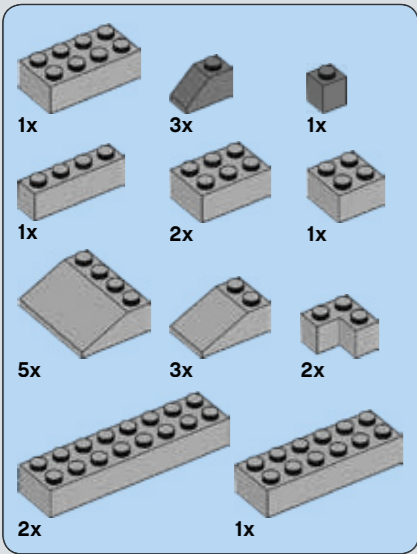

284

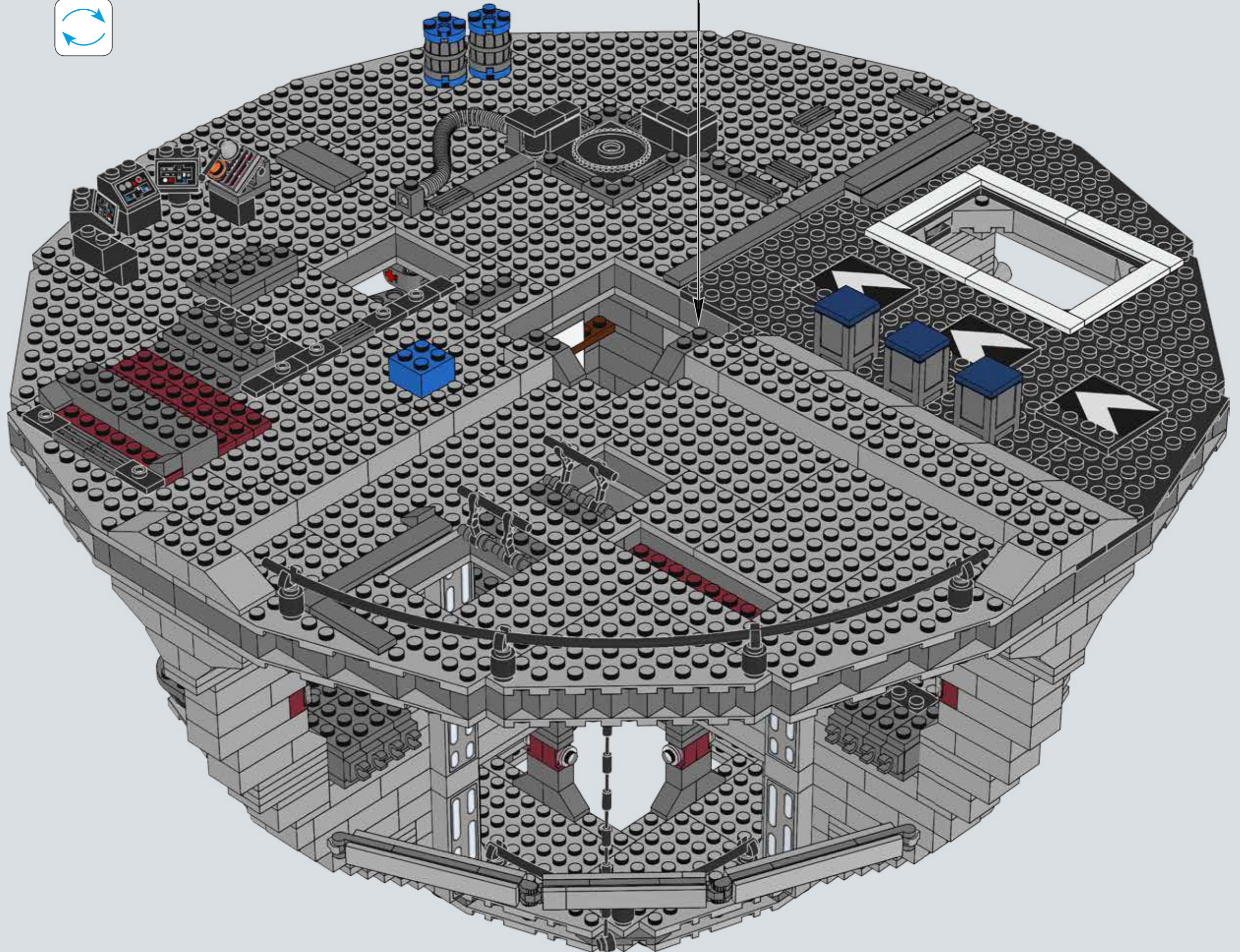
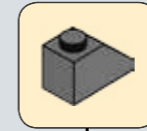
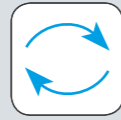

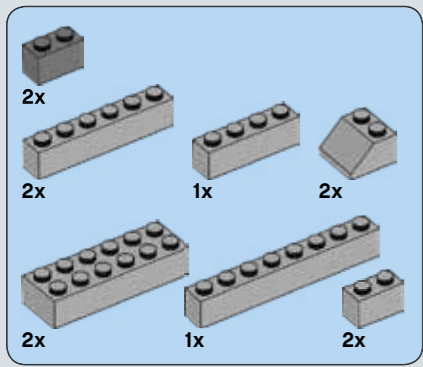

285

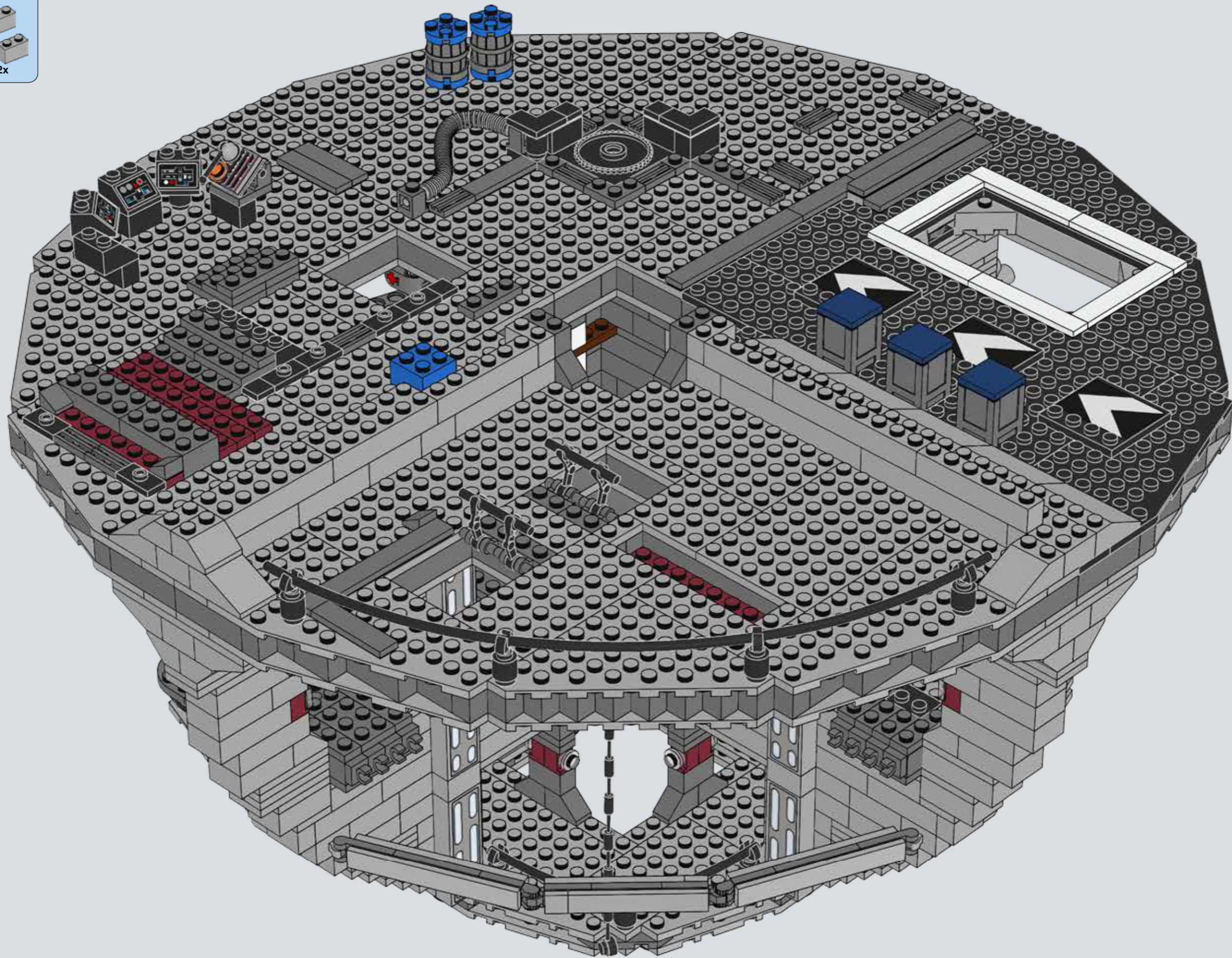



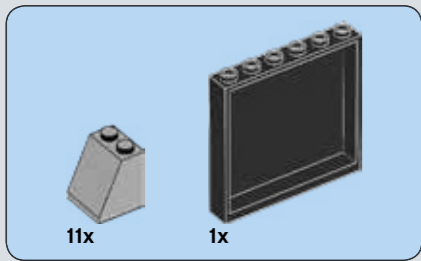

286

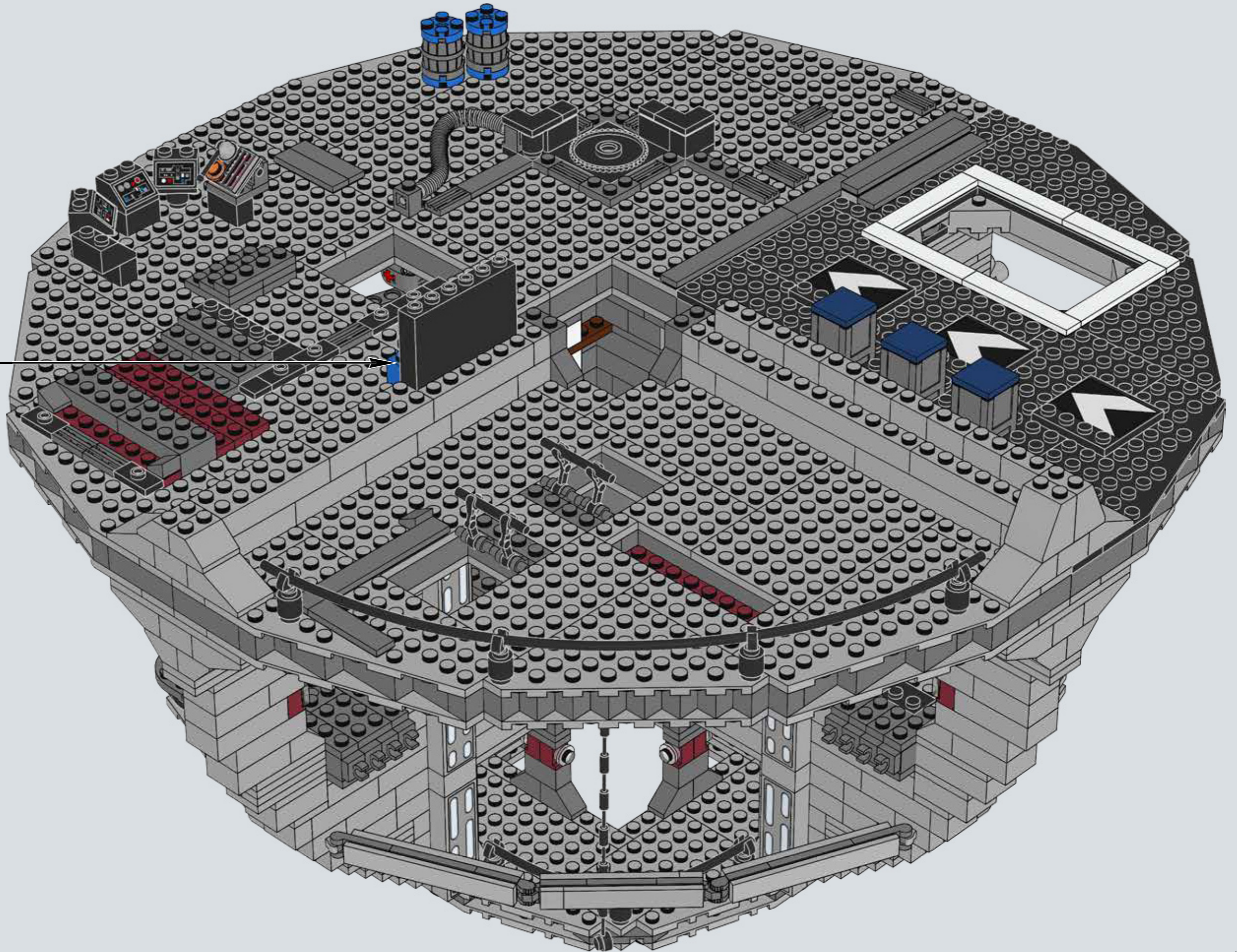
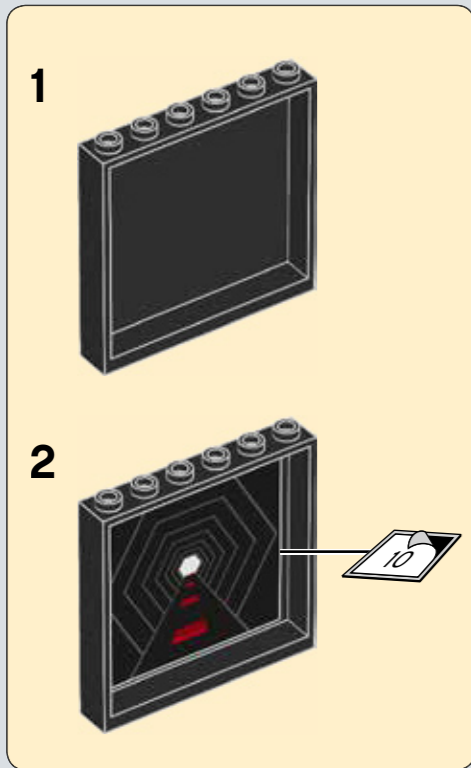

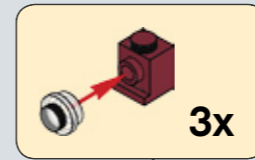
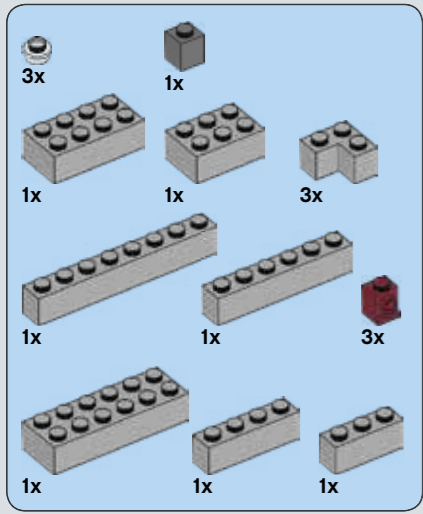

287

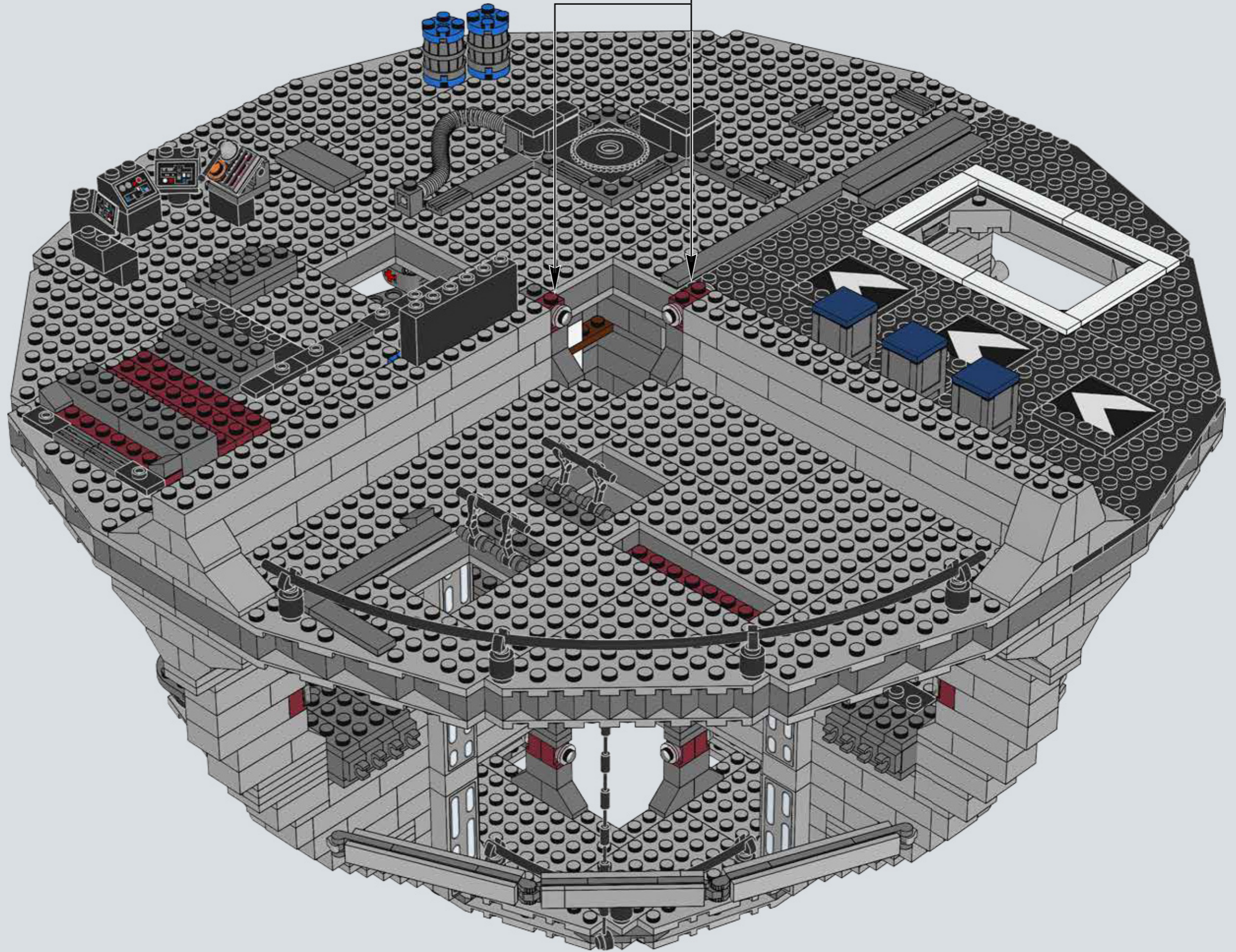

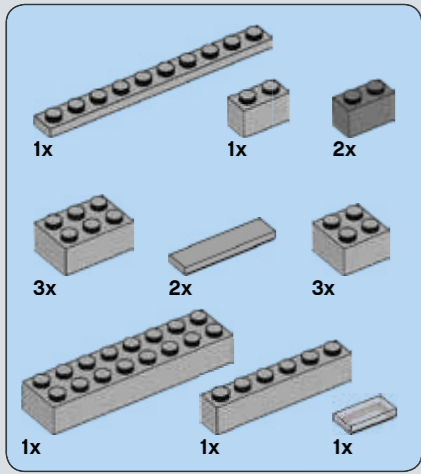

288

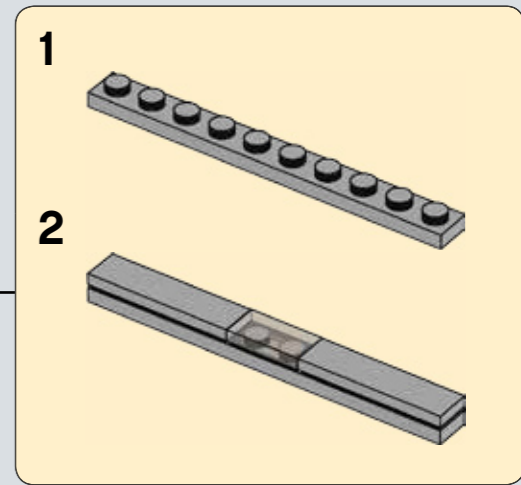
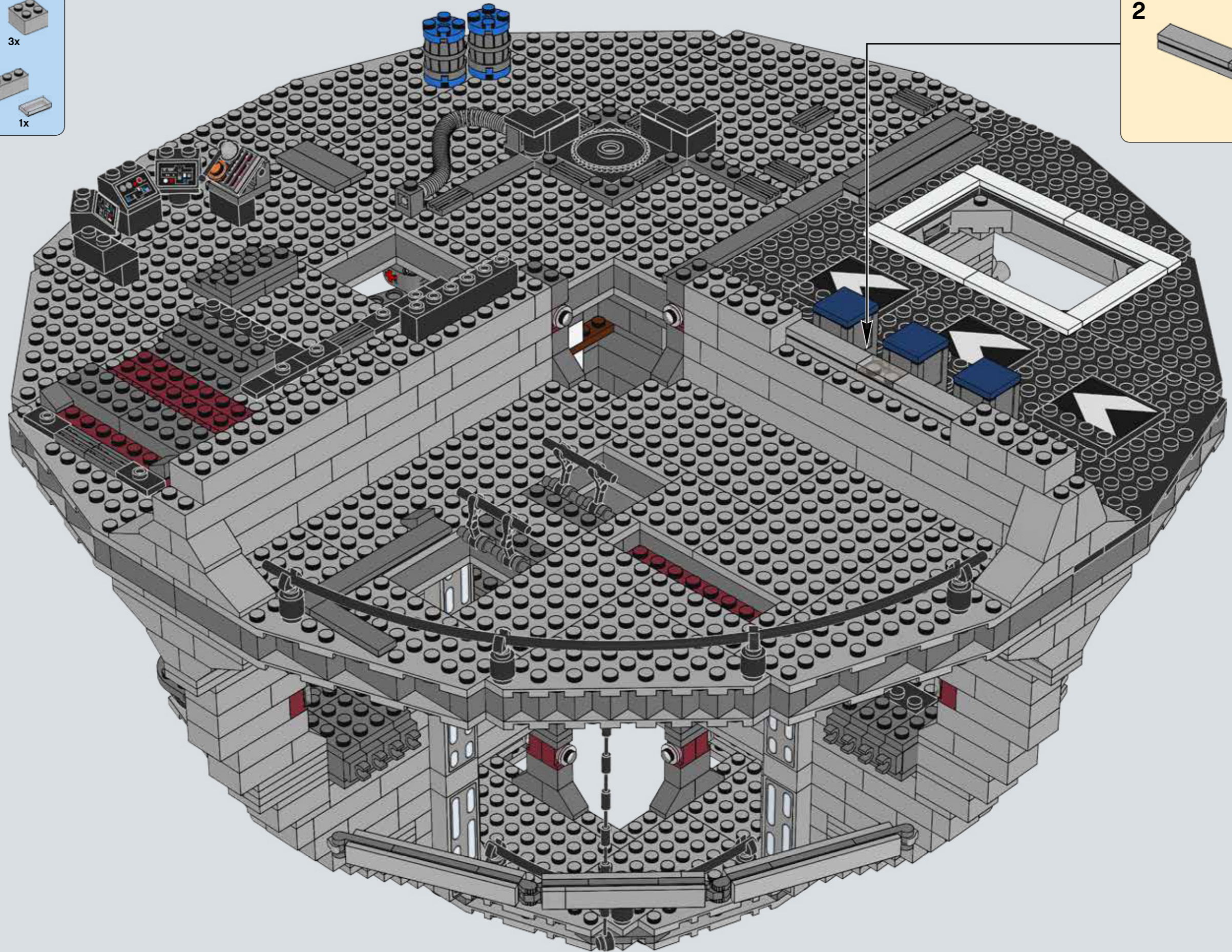

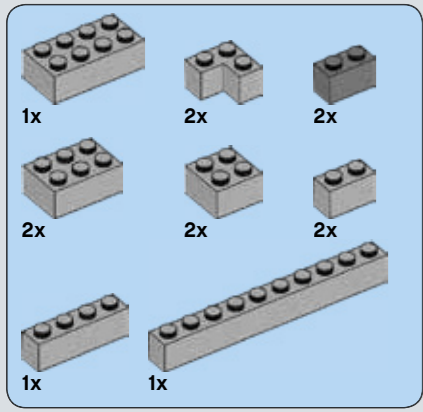

289

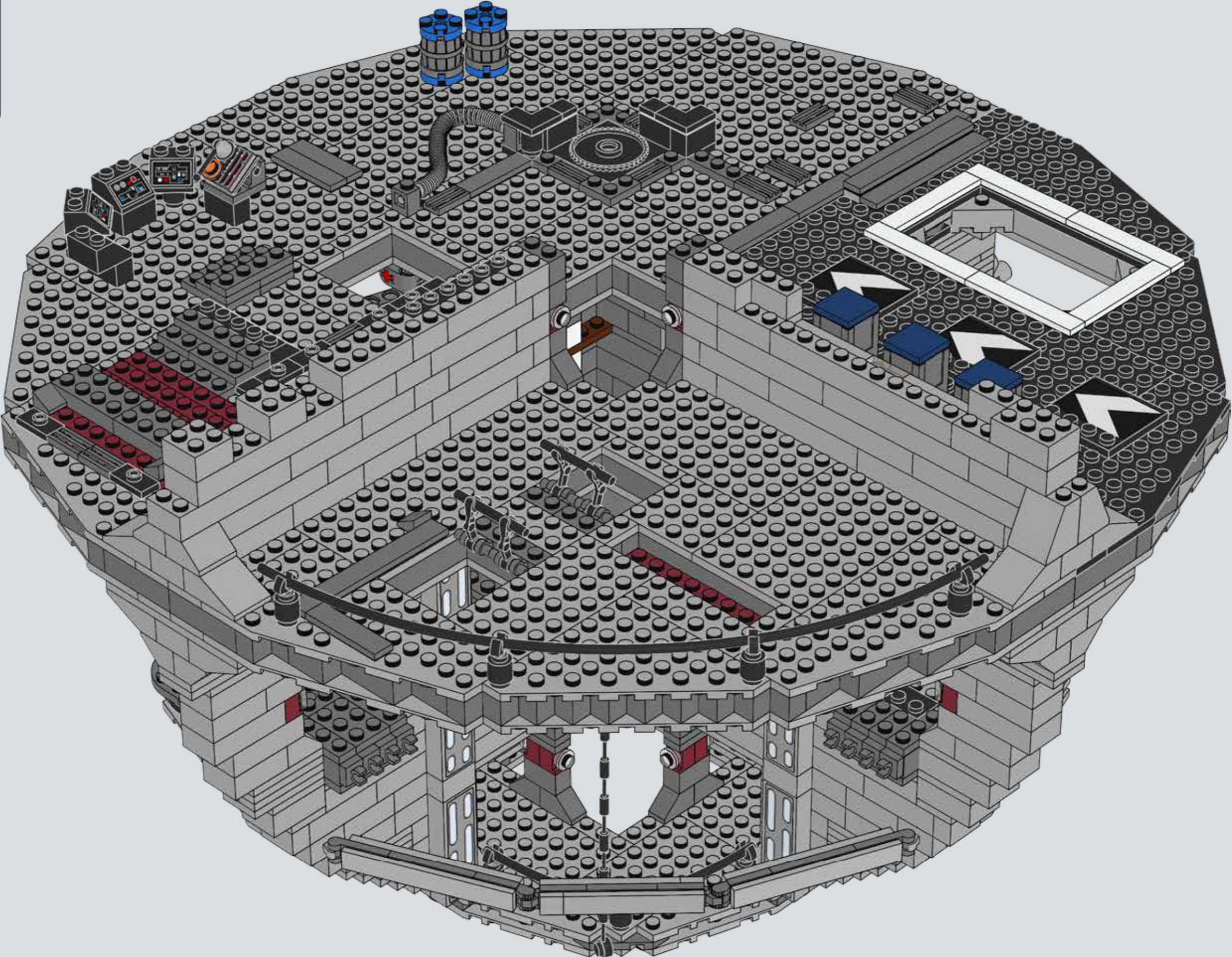



290

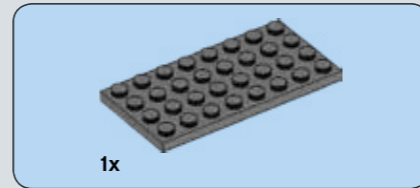
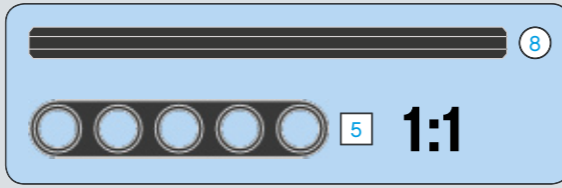

293

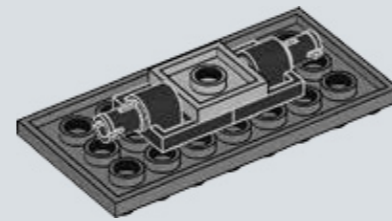
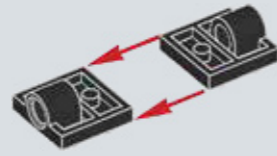

291

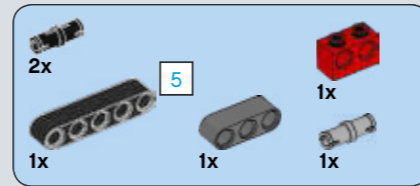
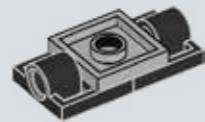

294

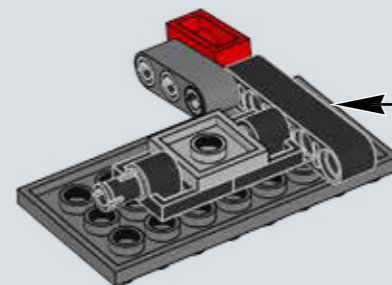
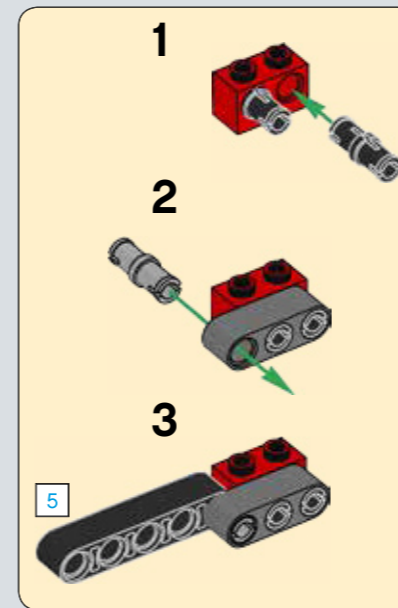

292

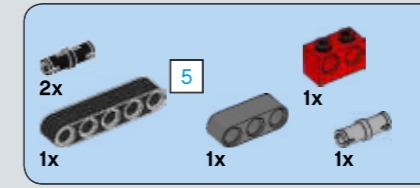
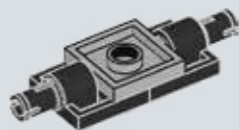

295

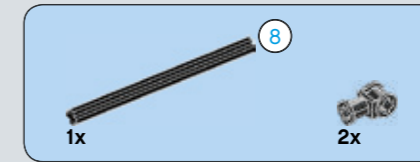
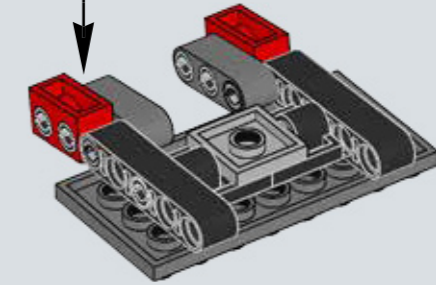
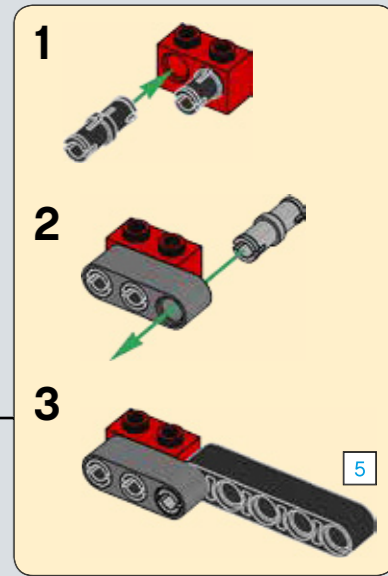

296

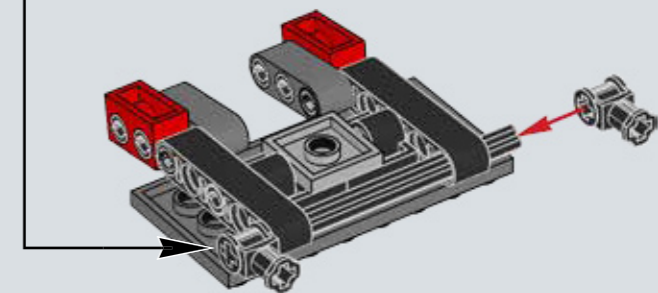
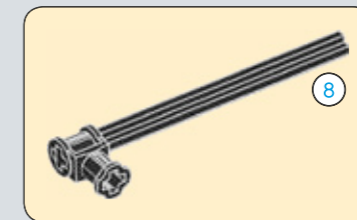



297

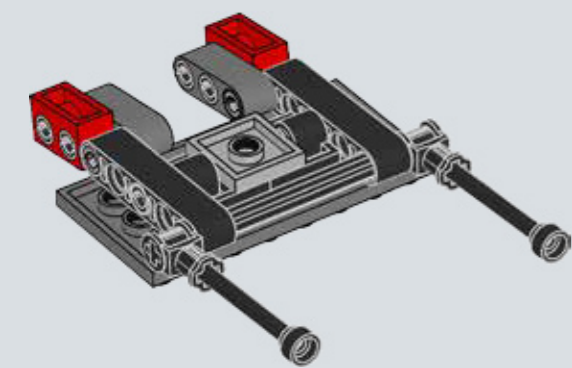

298

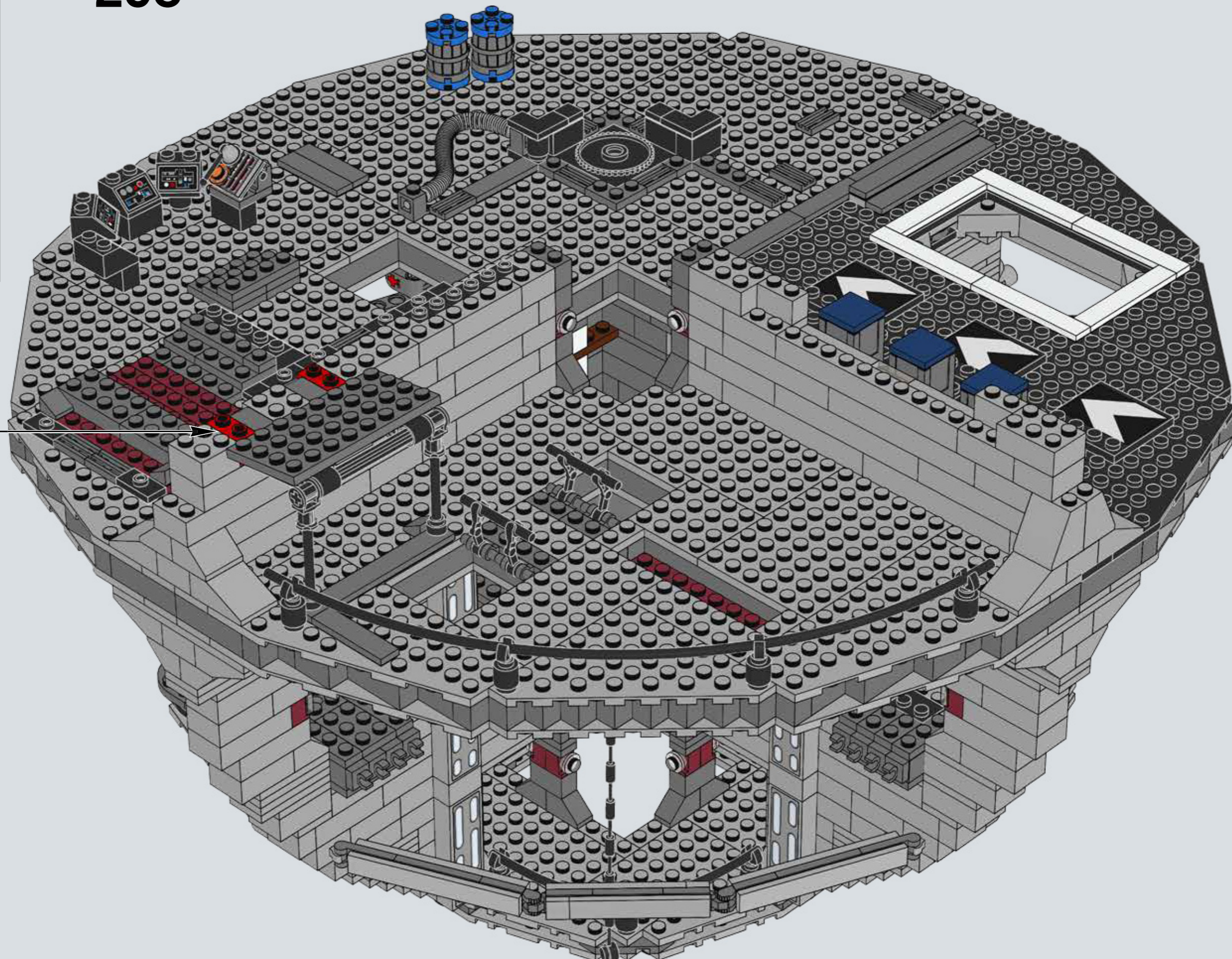

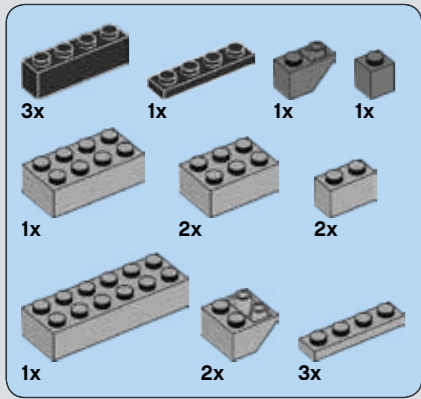

299

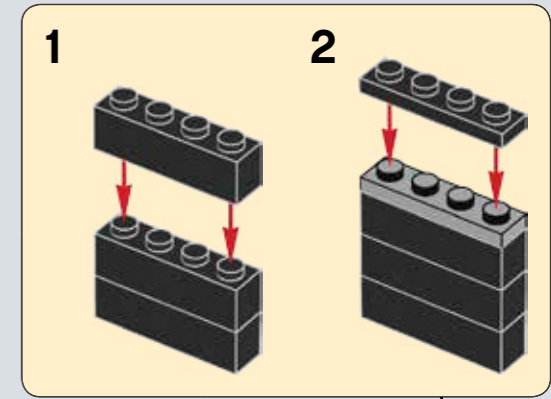
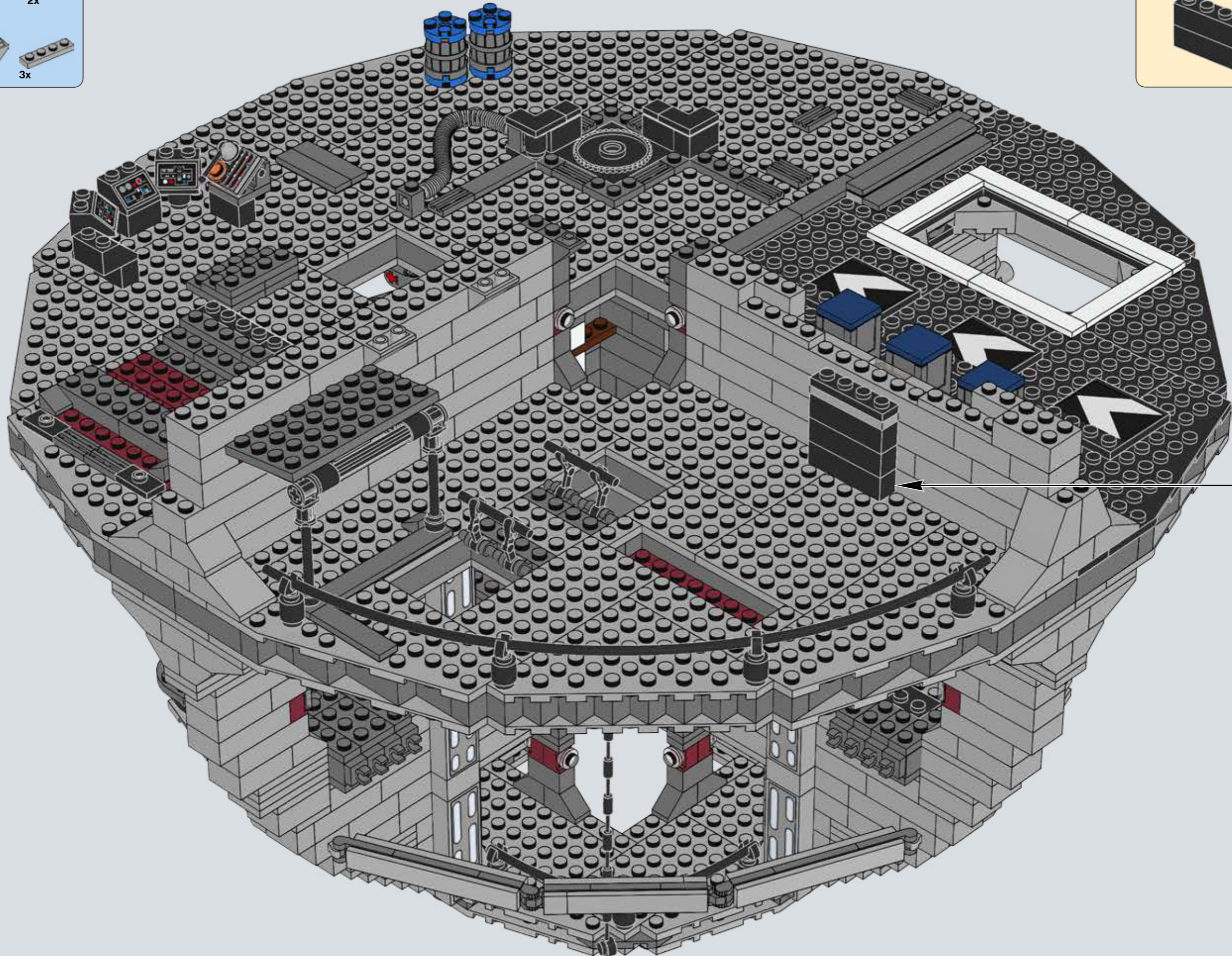

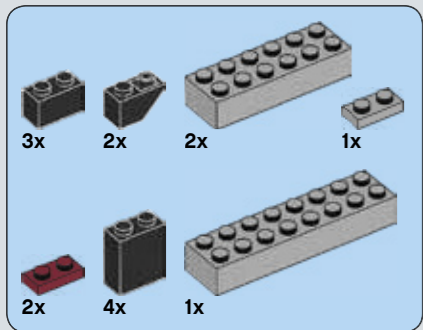

300

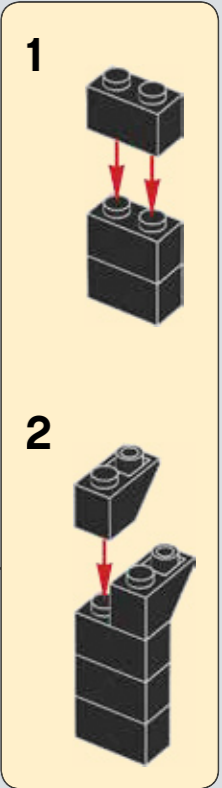
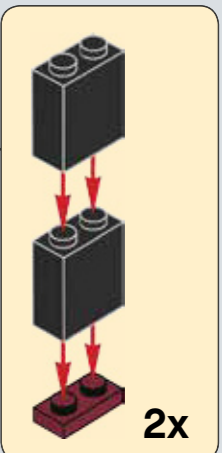
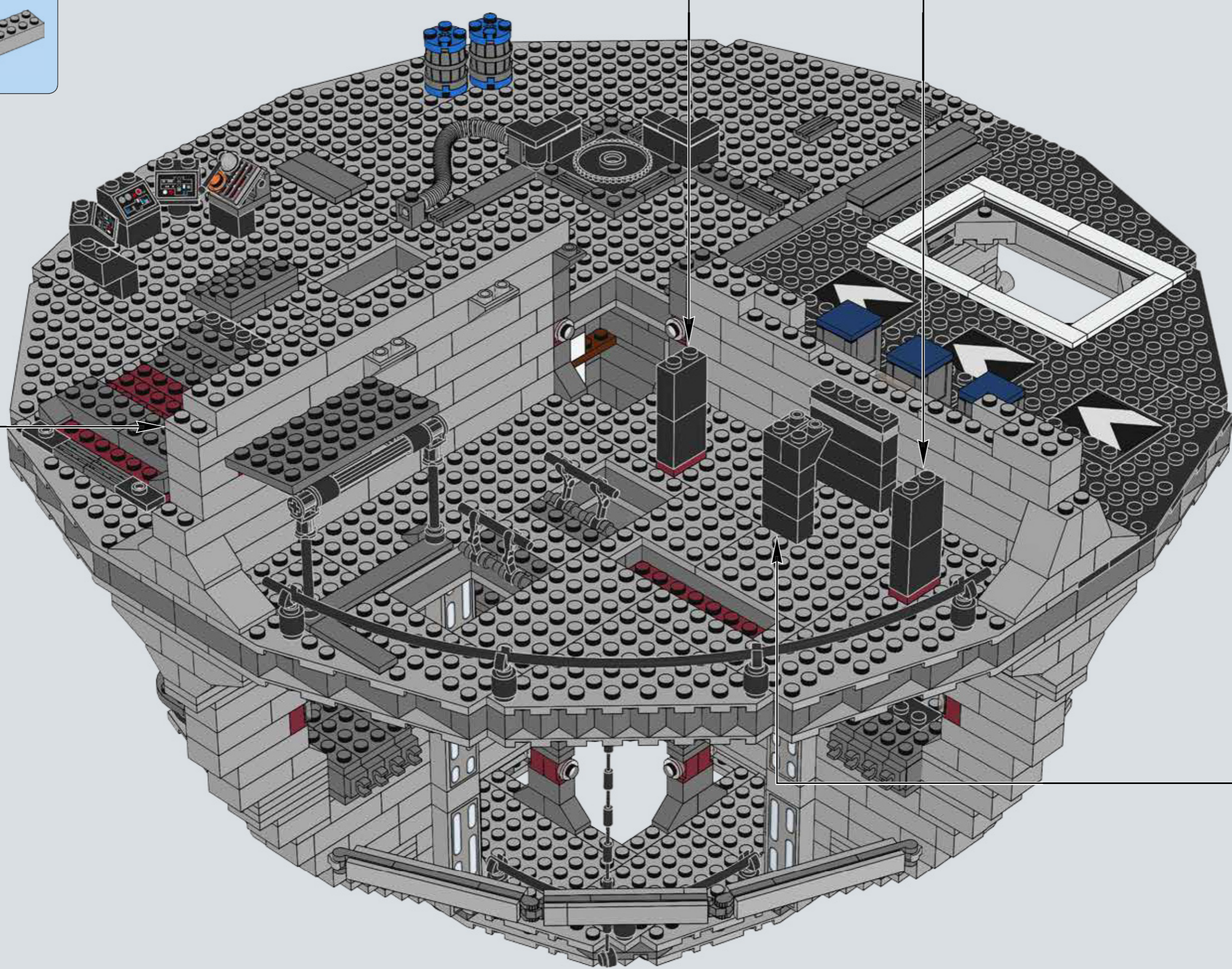



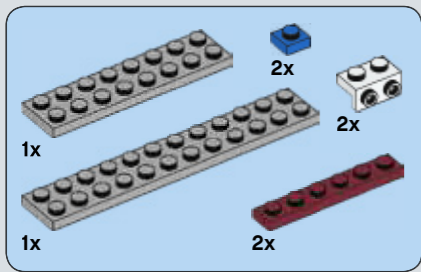

301

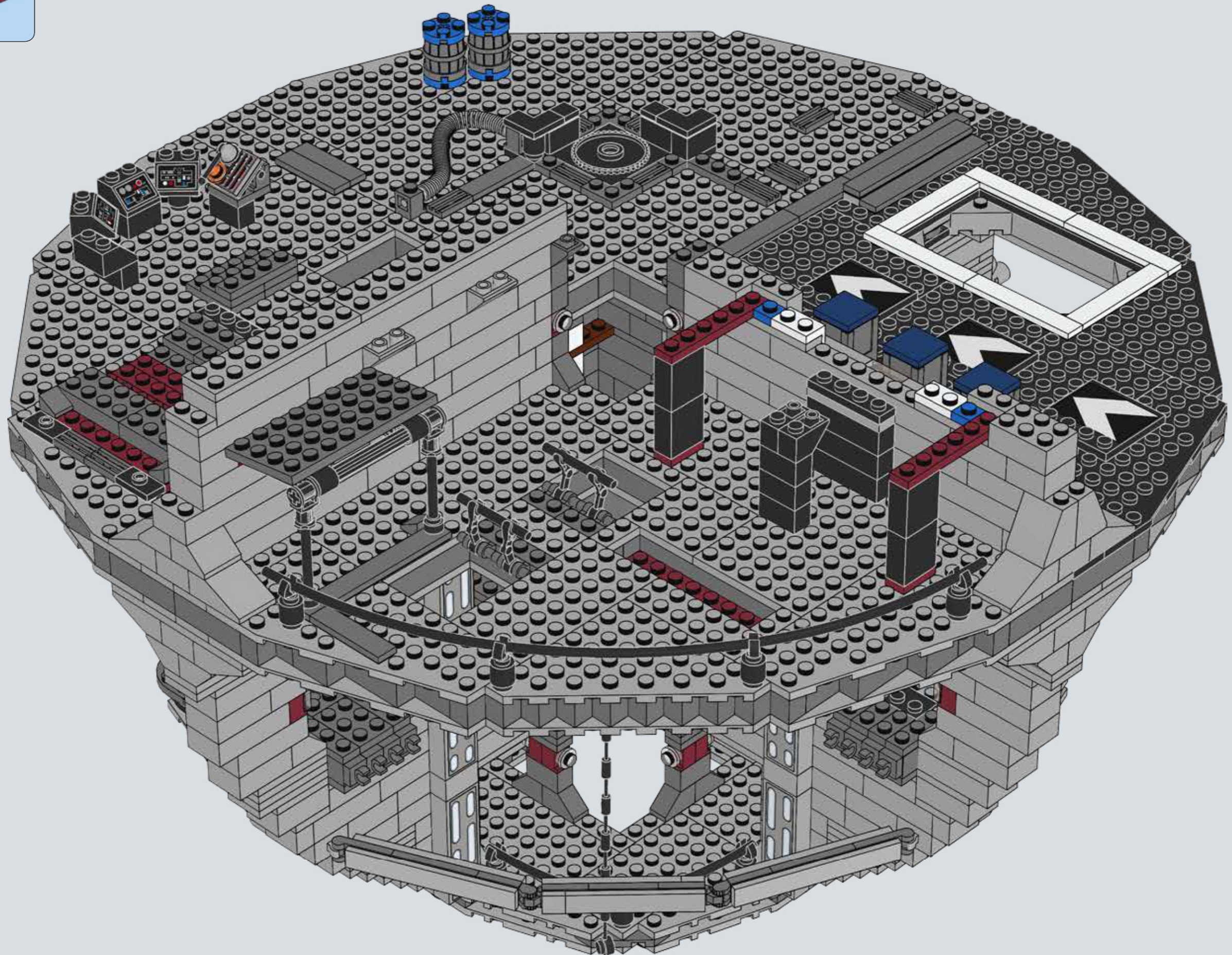

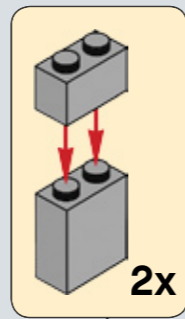
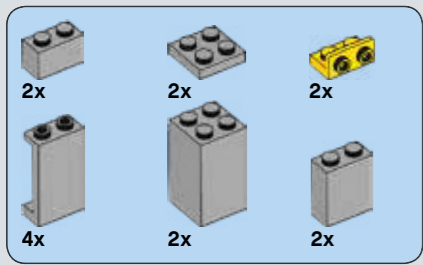

302

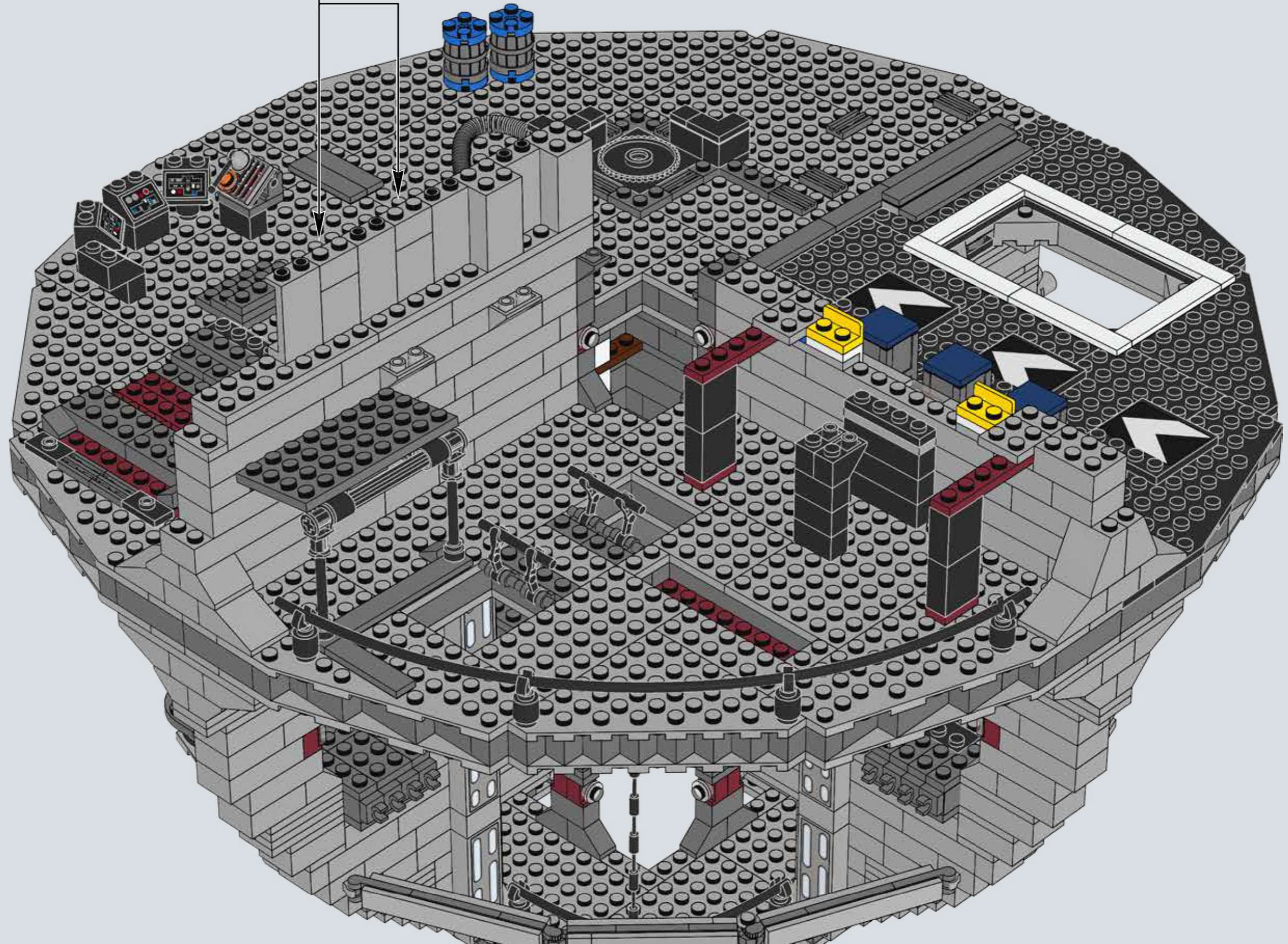

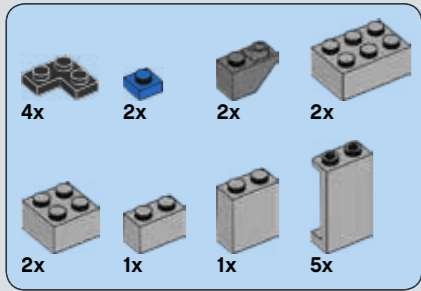

303

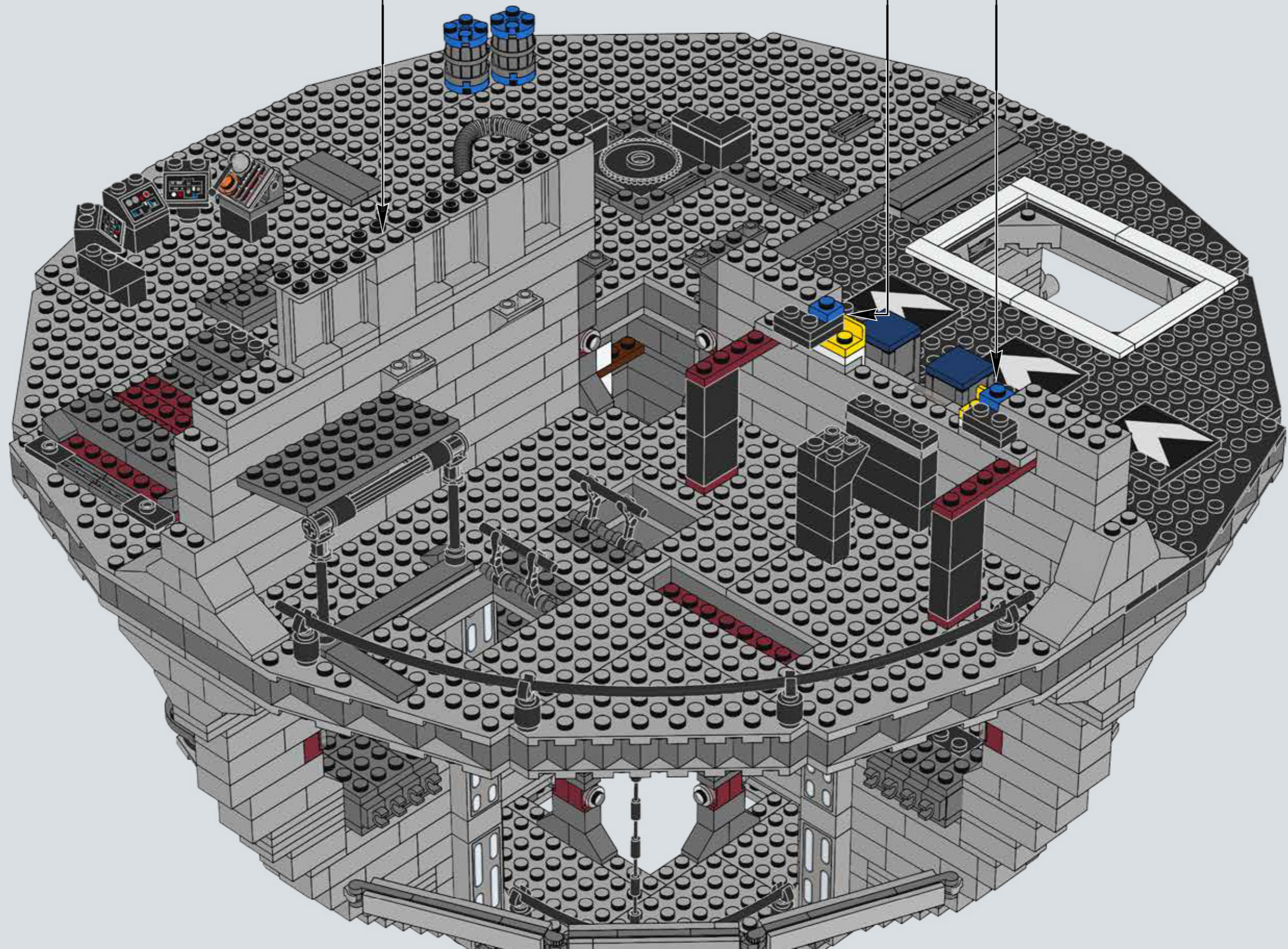
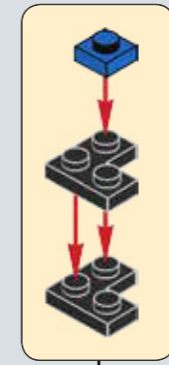
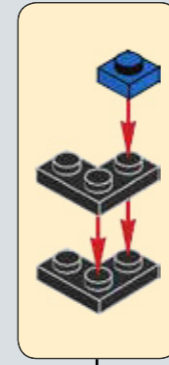
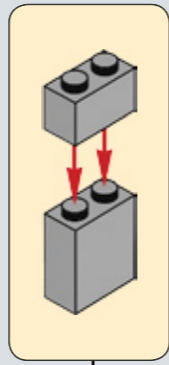

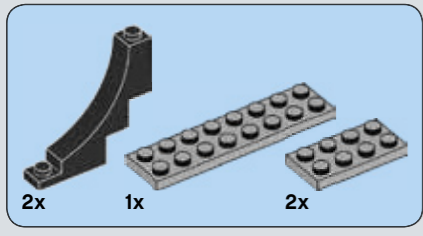

# 304

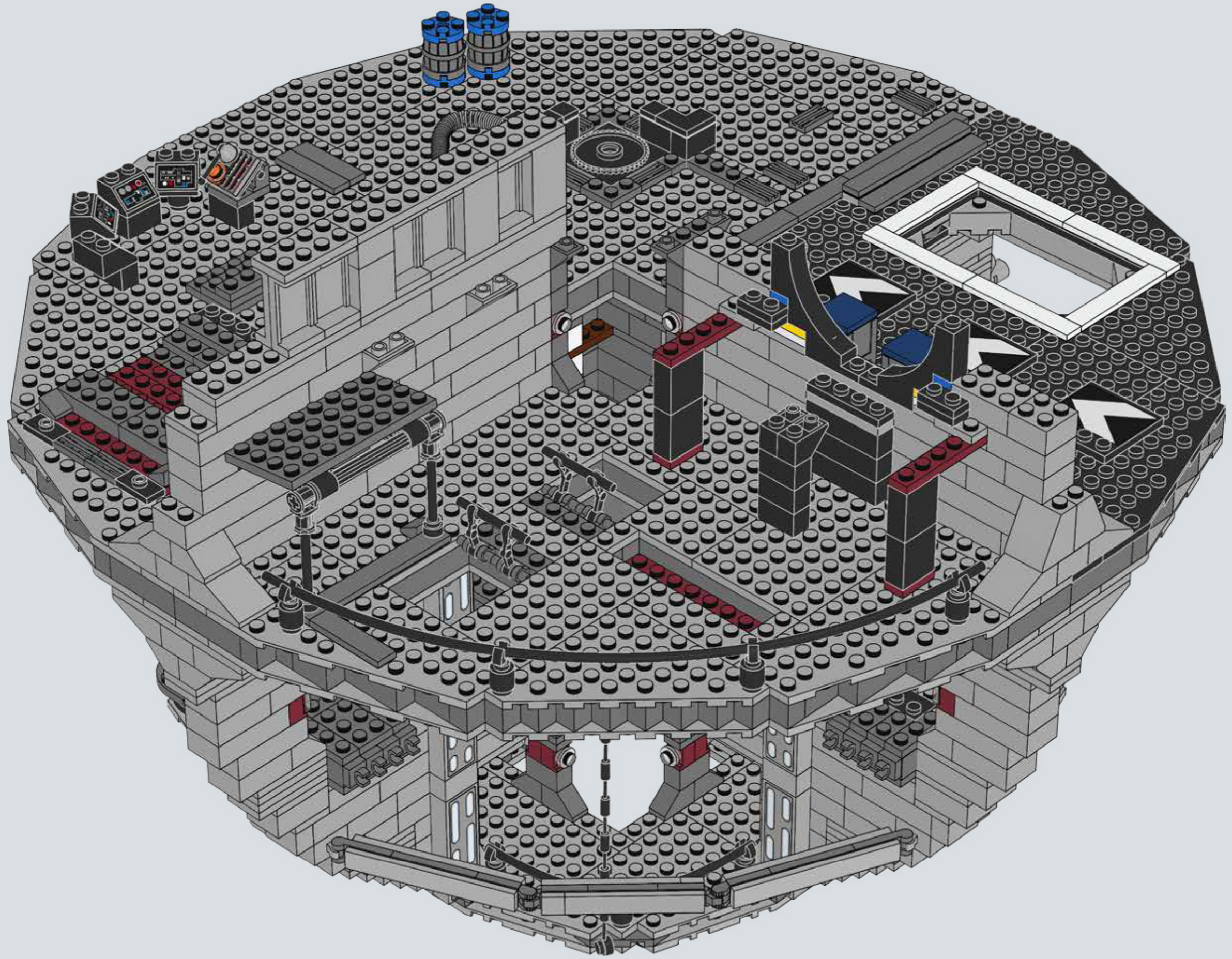

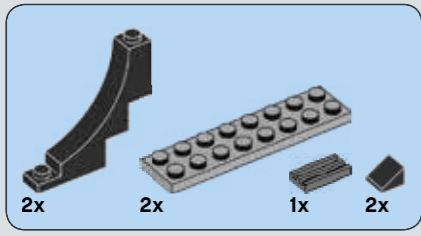

305

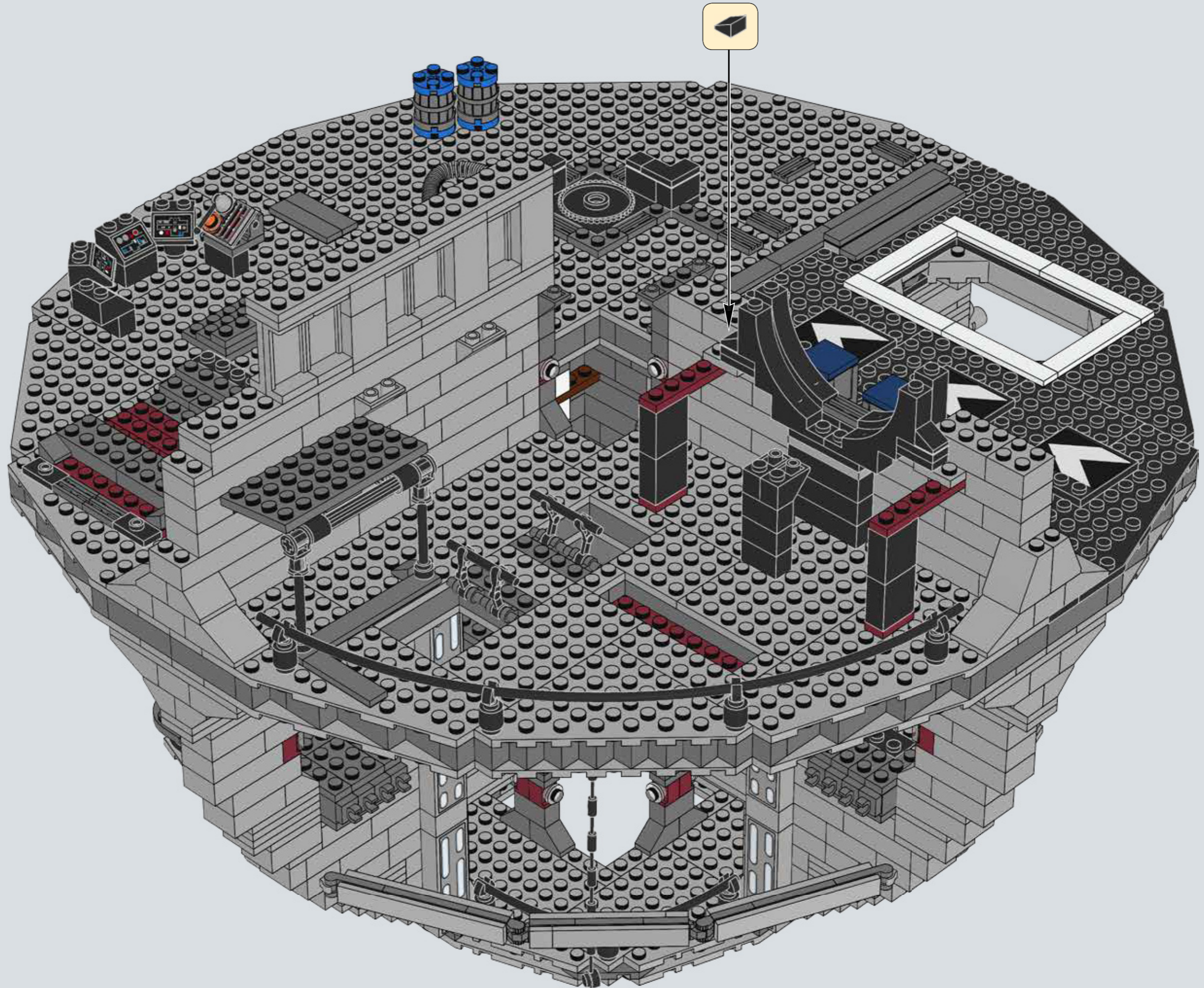

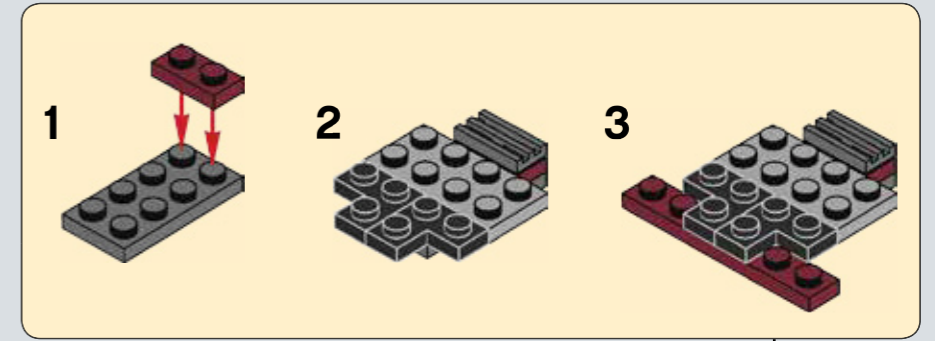
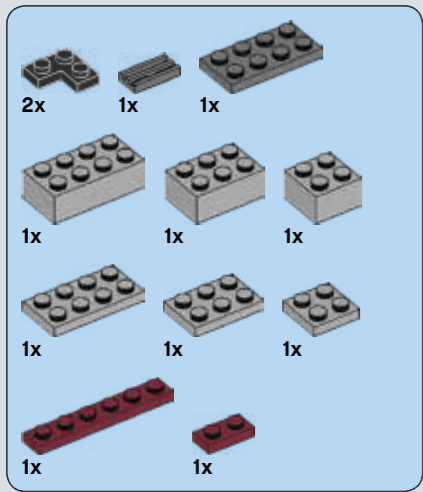

# 306

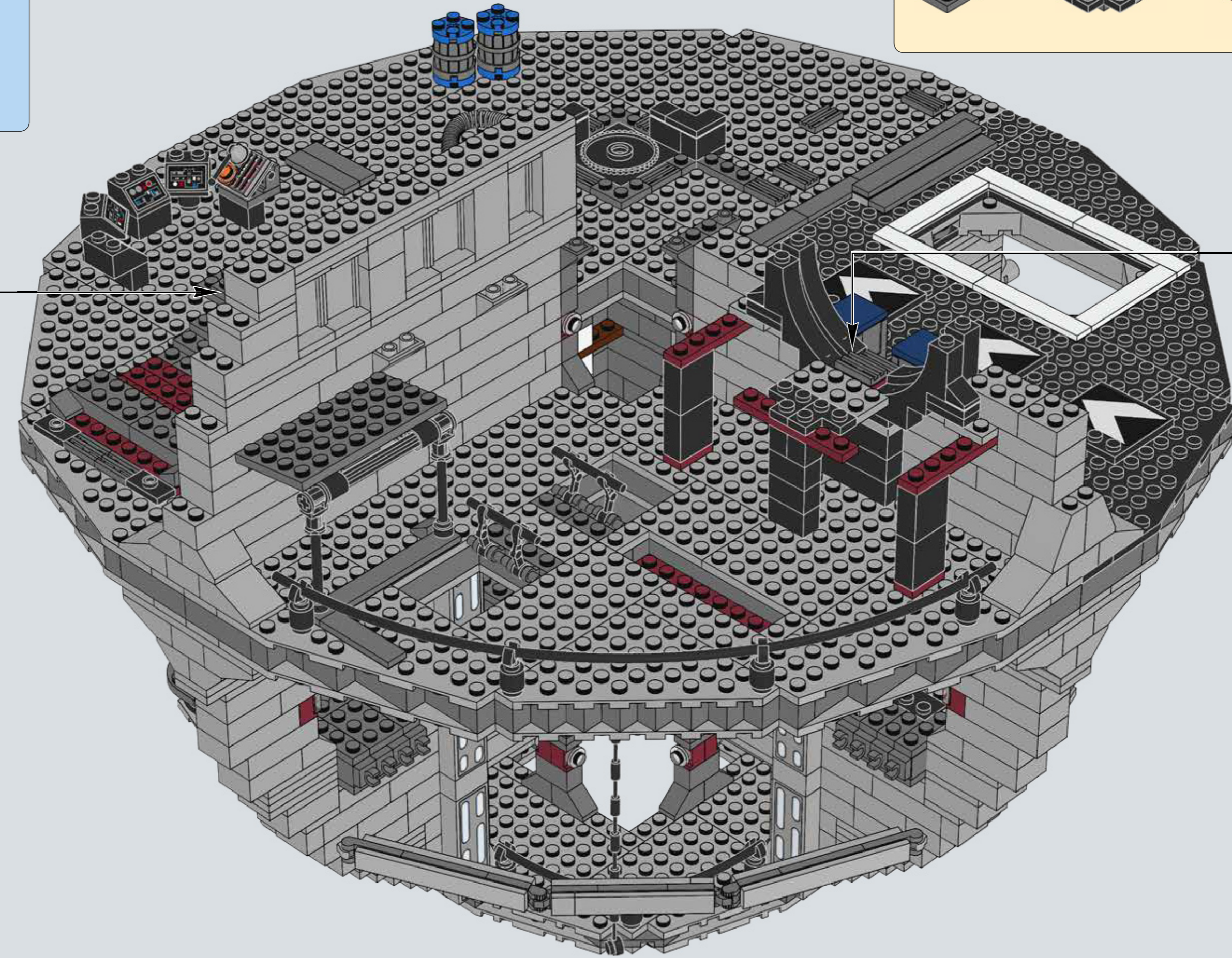
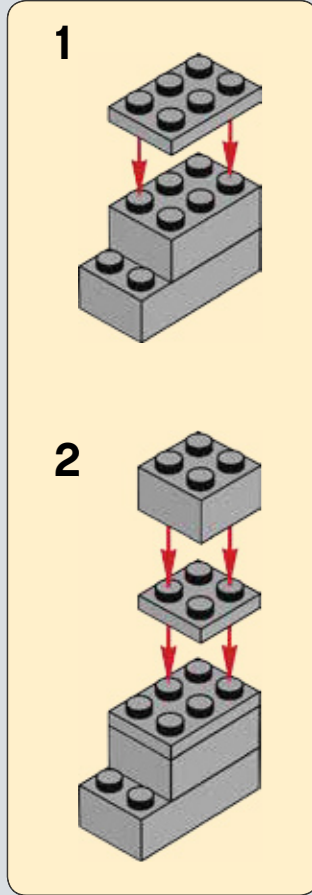

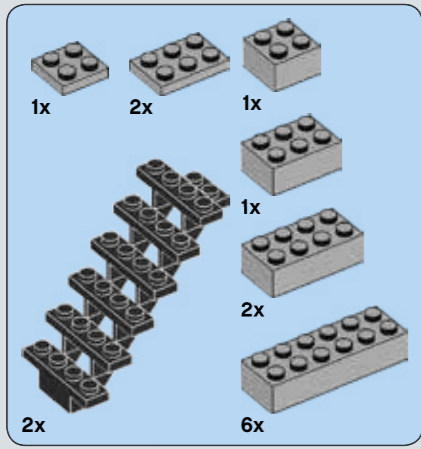

307

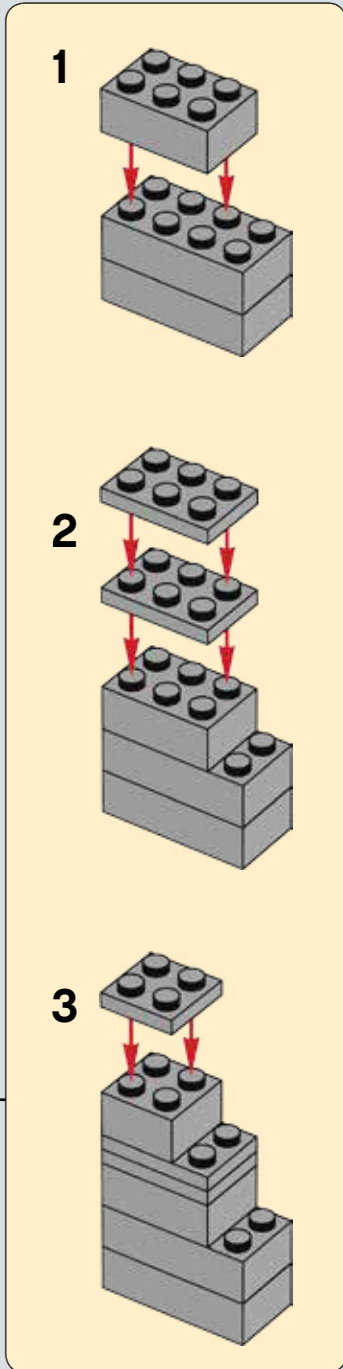
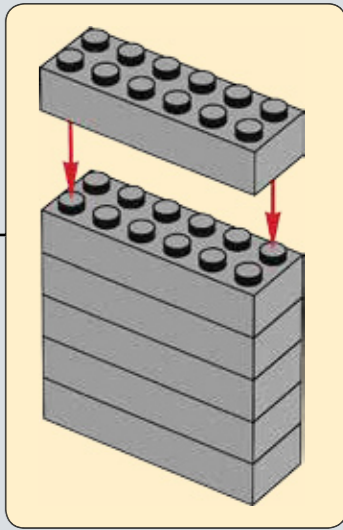
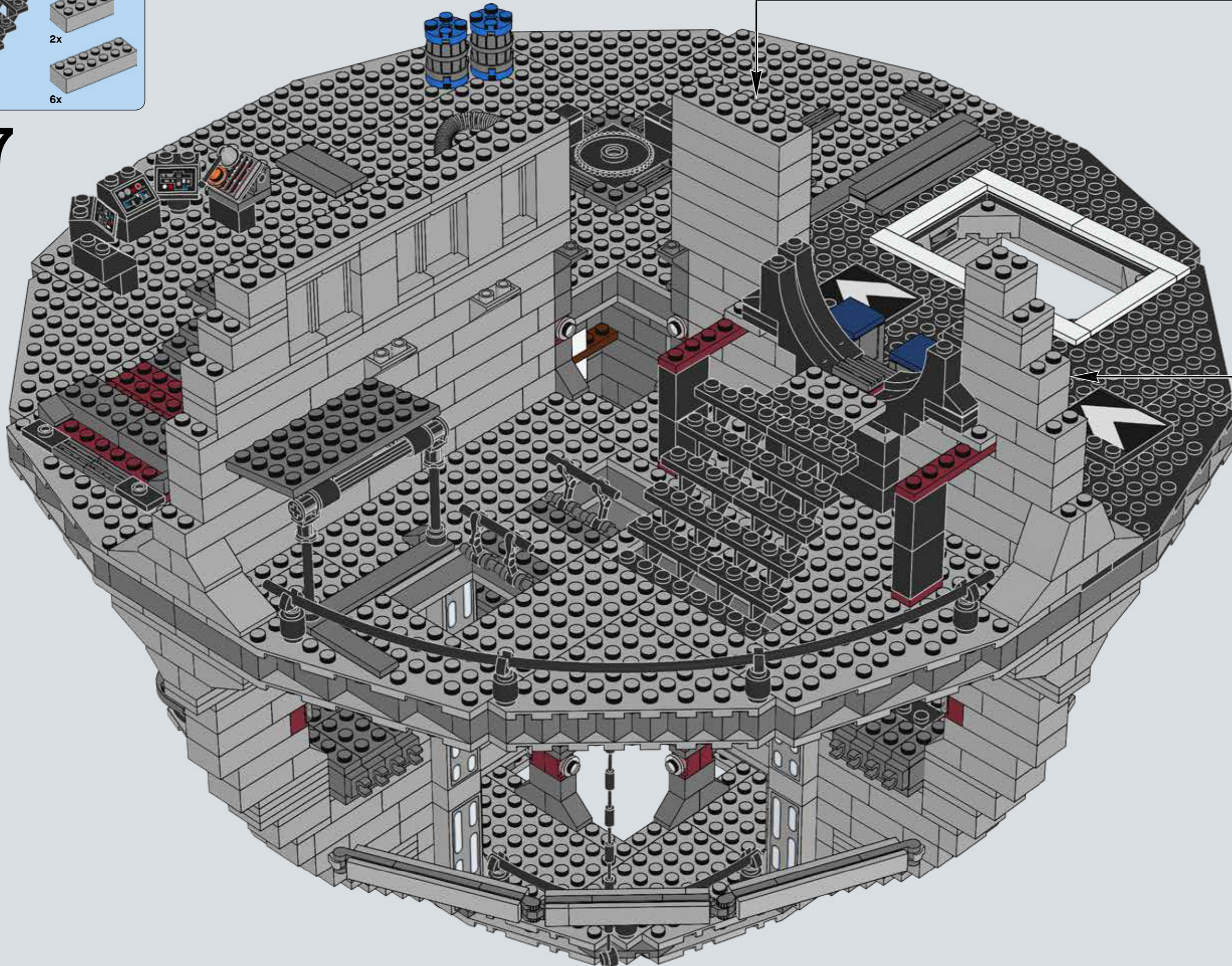

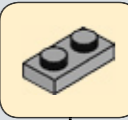
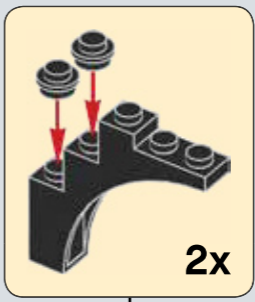
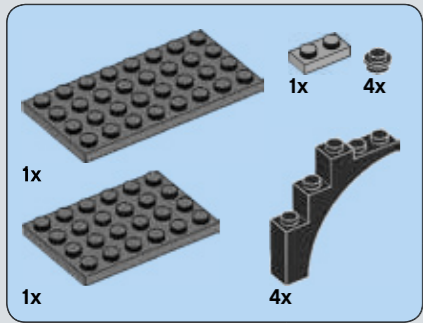

308

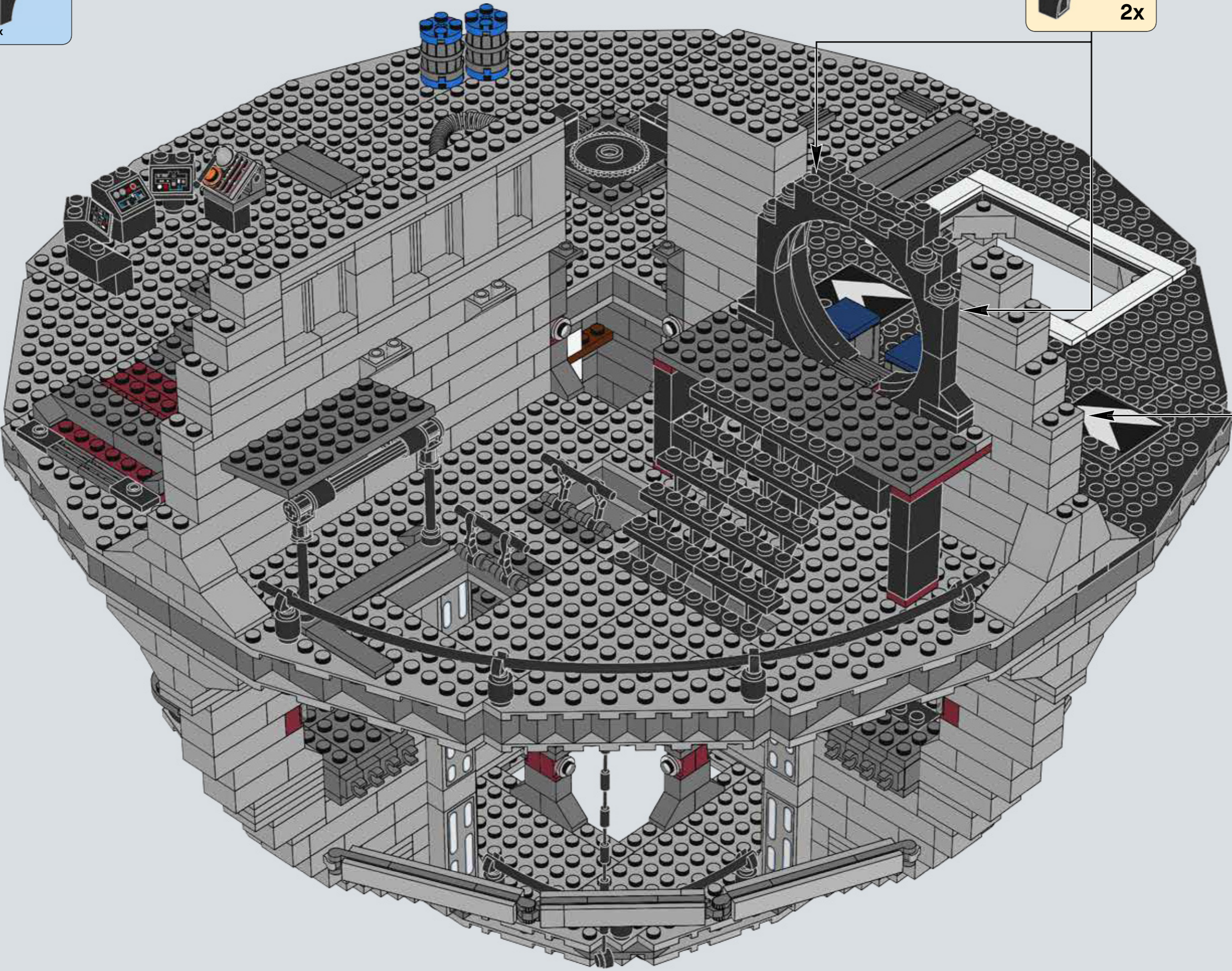



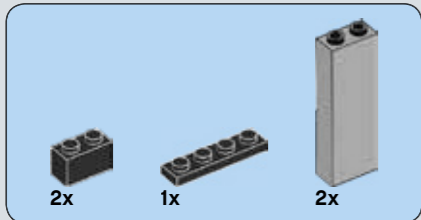

309

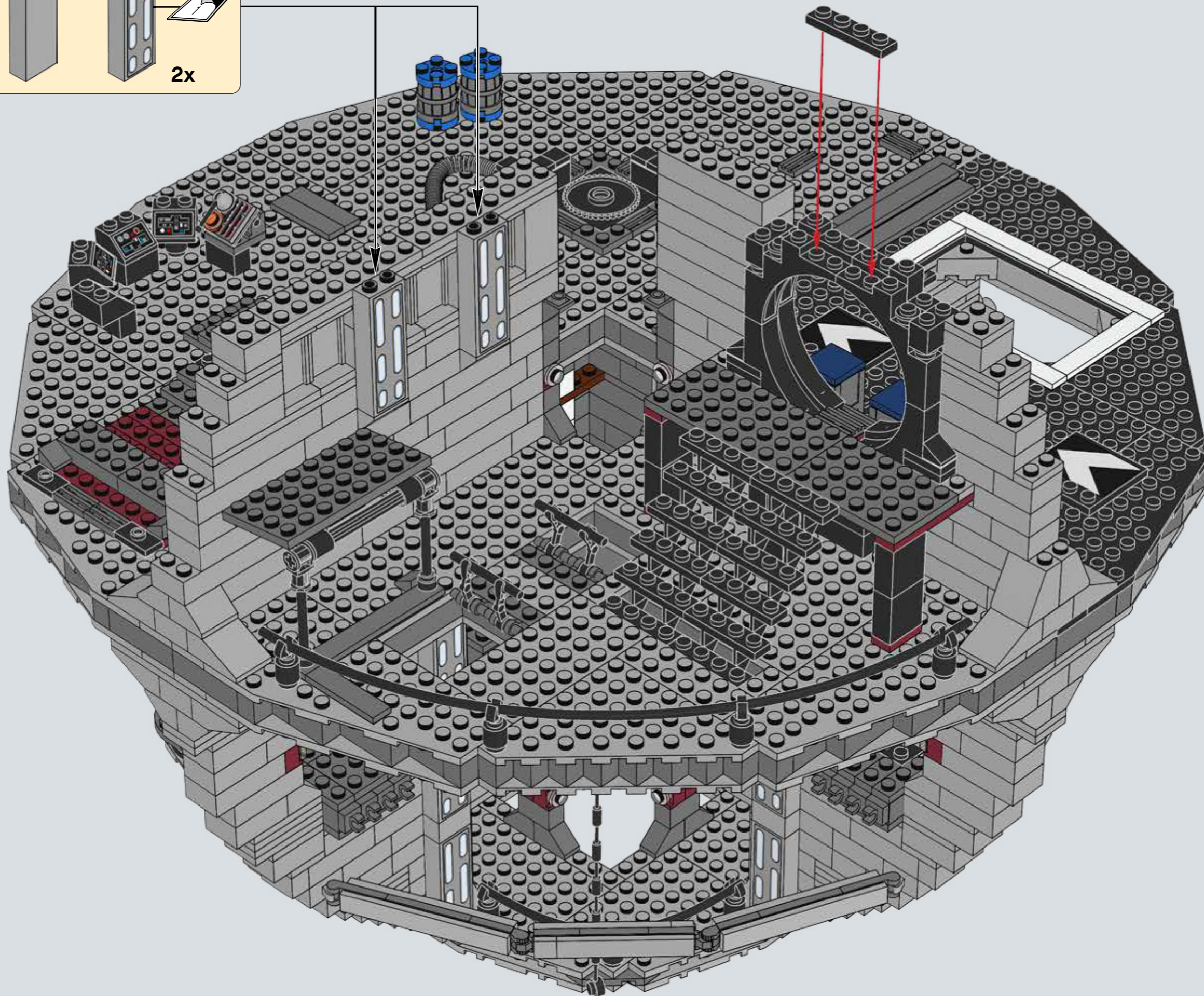
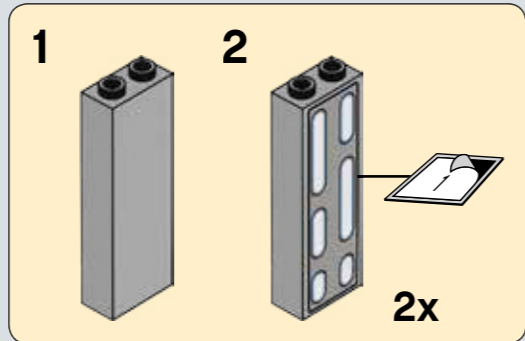

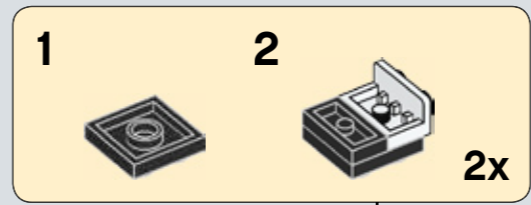
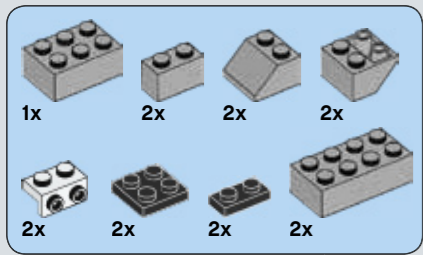

# 310

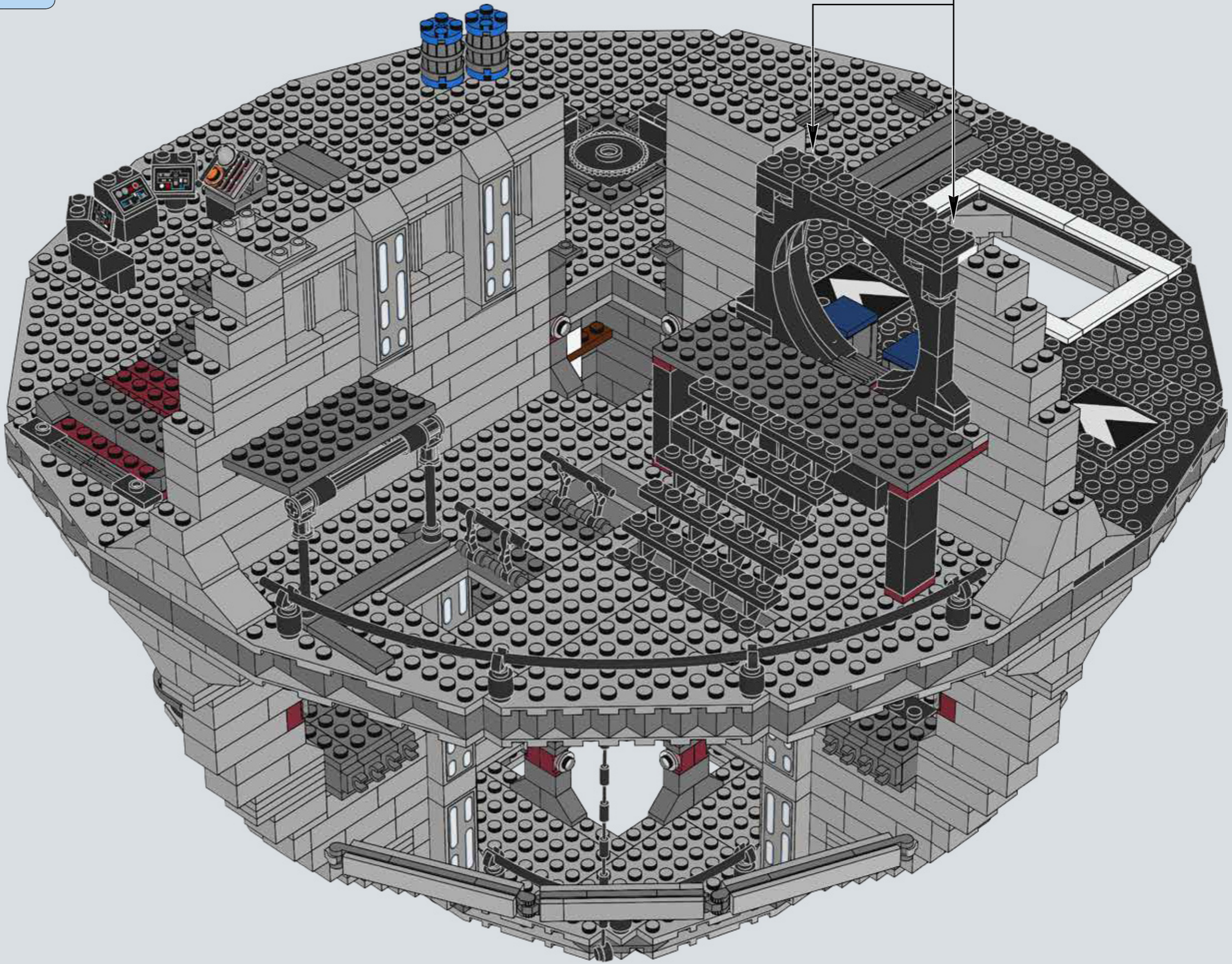

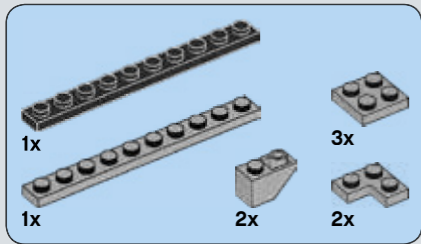

311

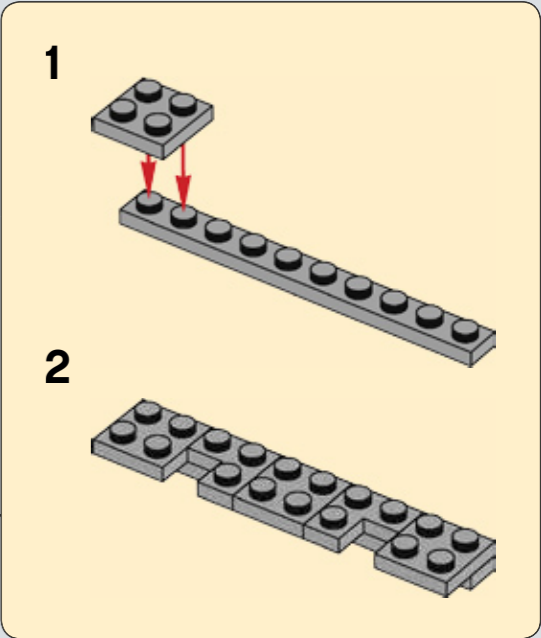
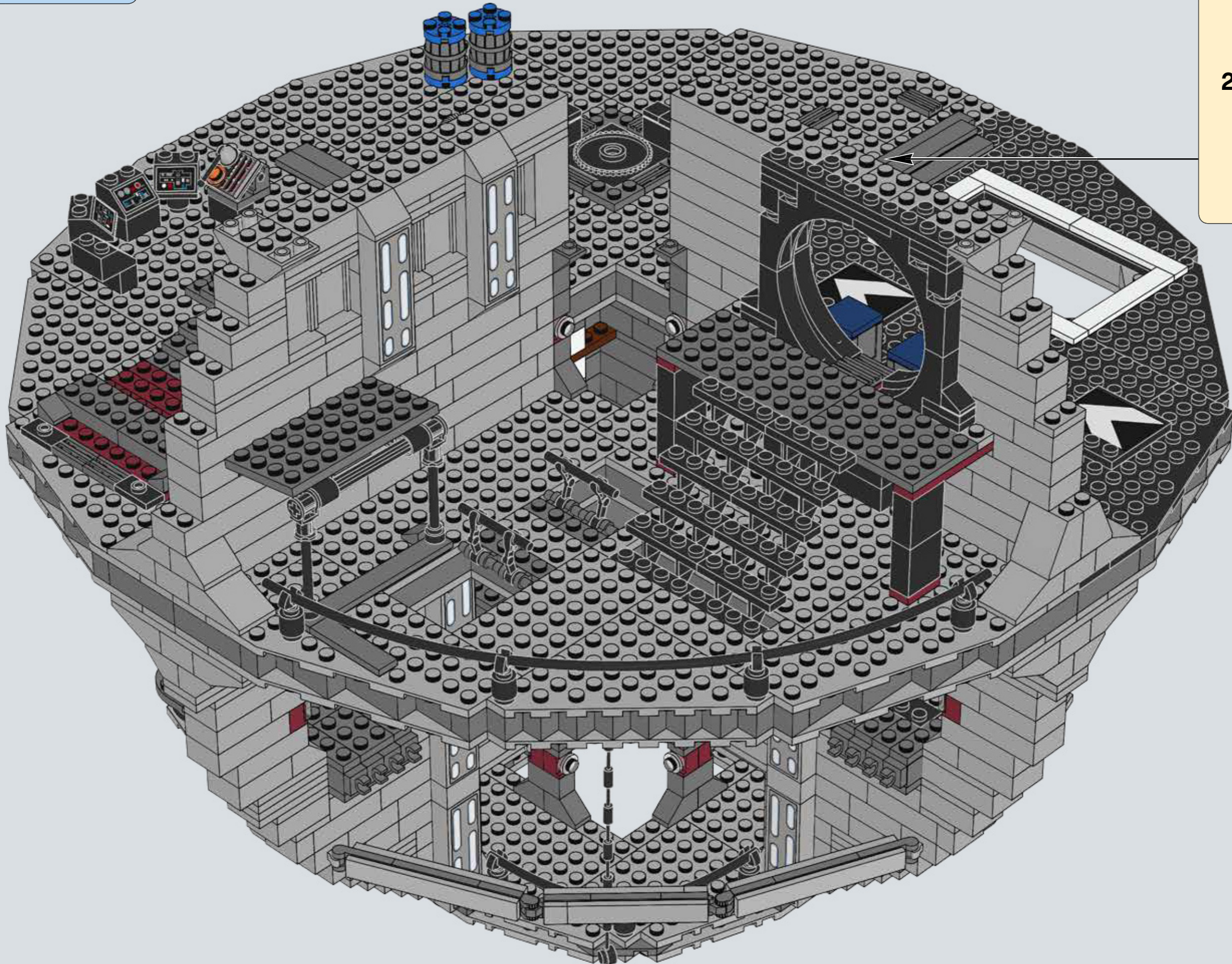

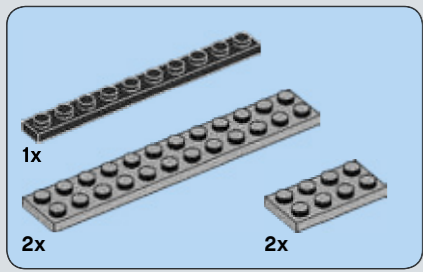

# 312

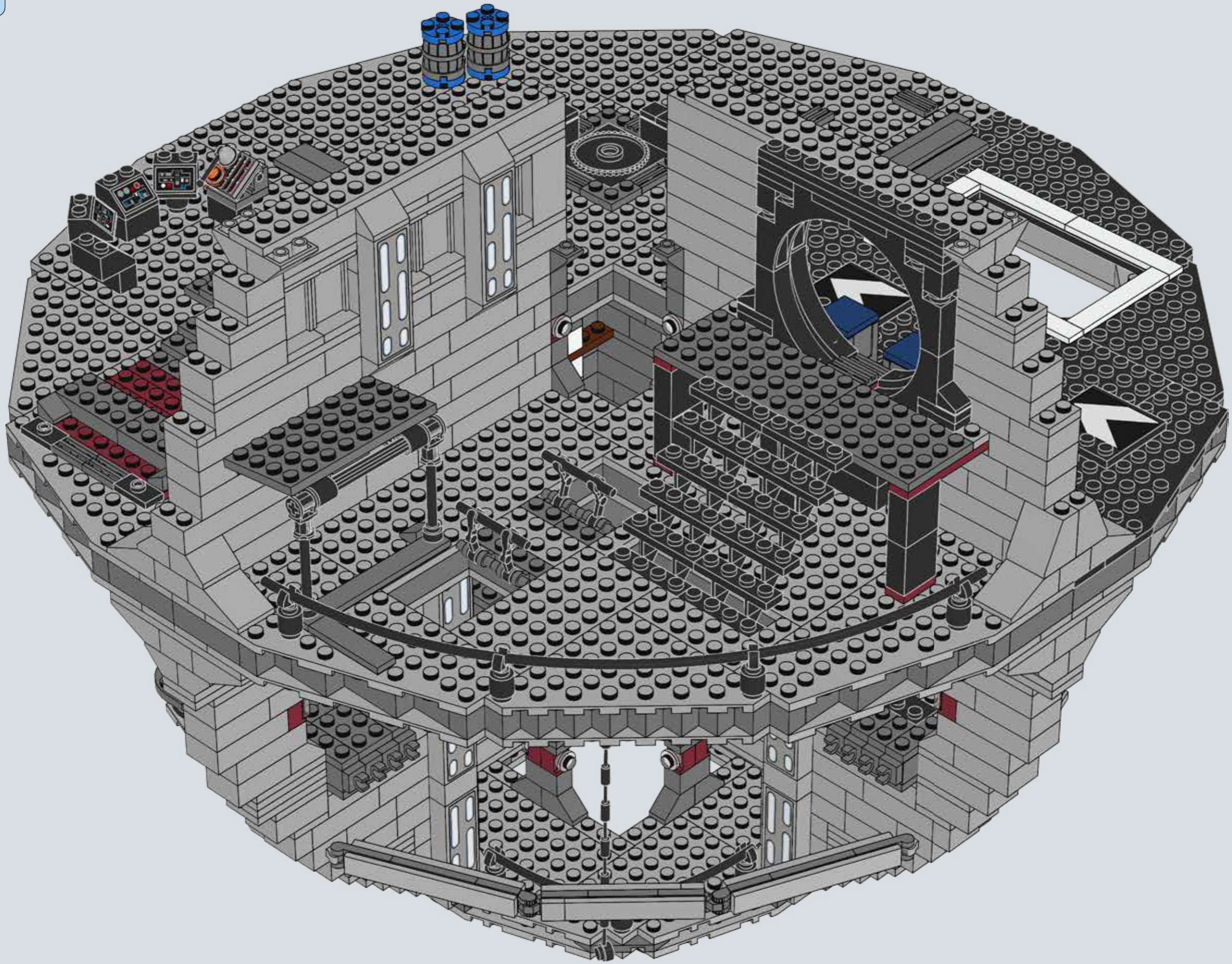

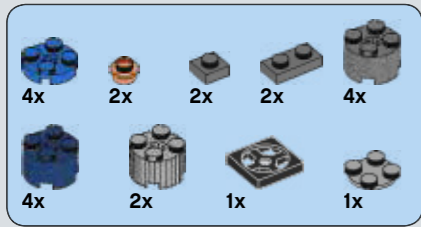

313

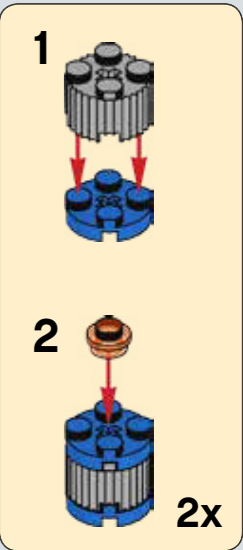
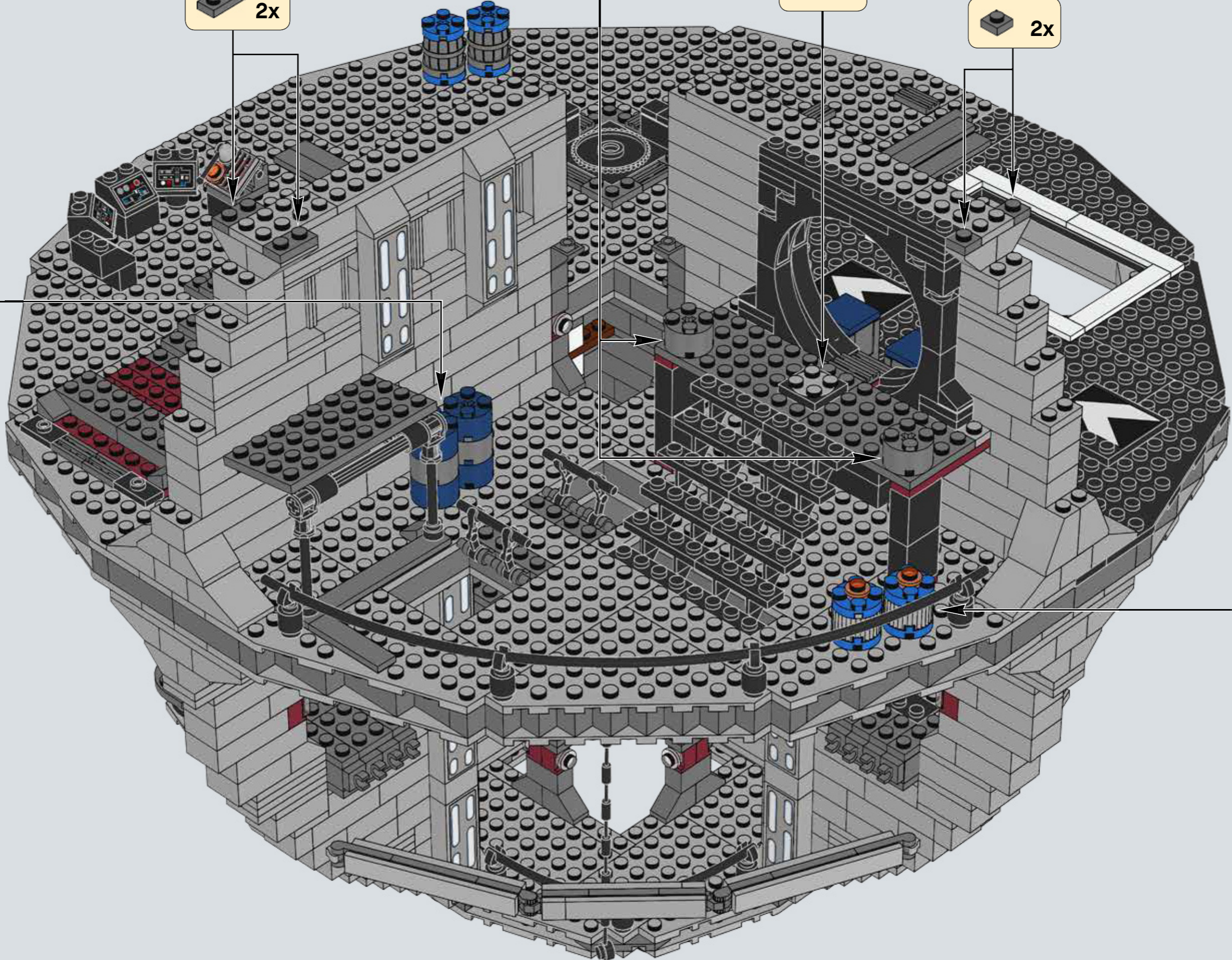
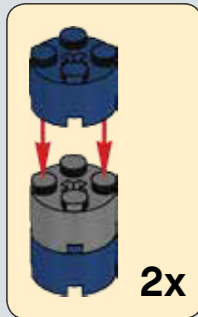
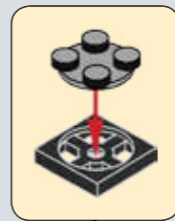

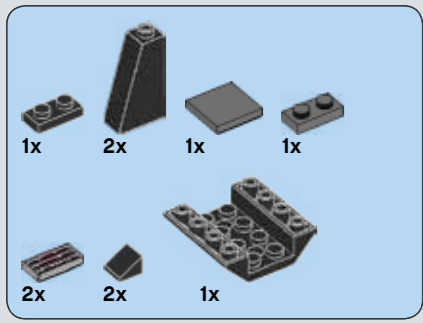

314

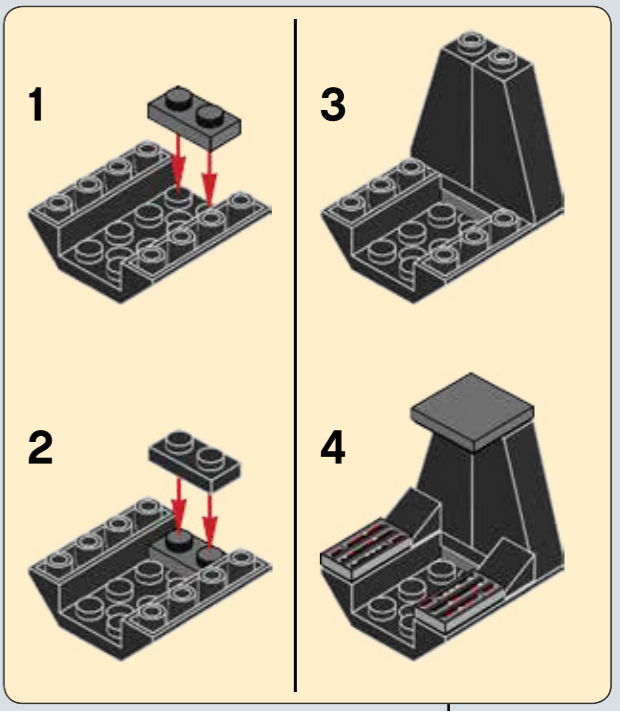
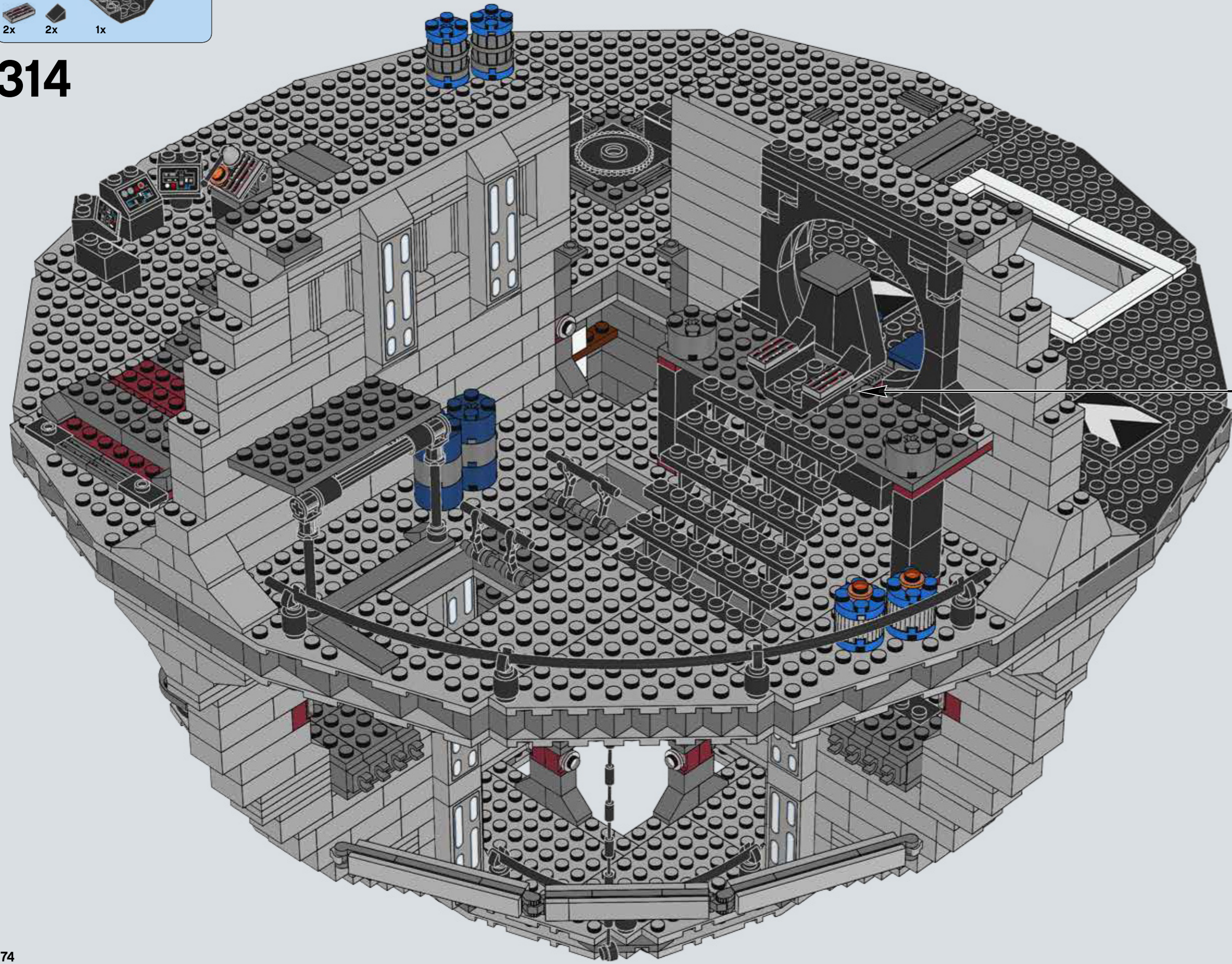



315

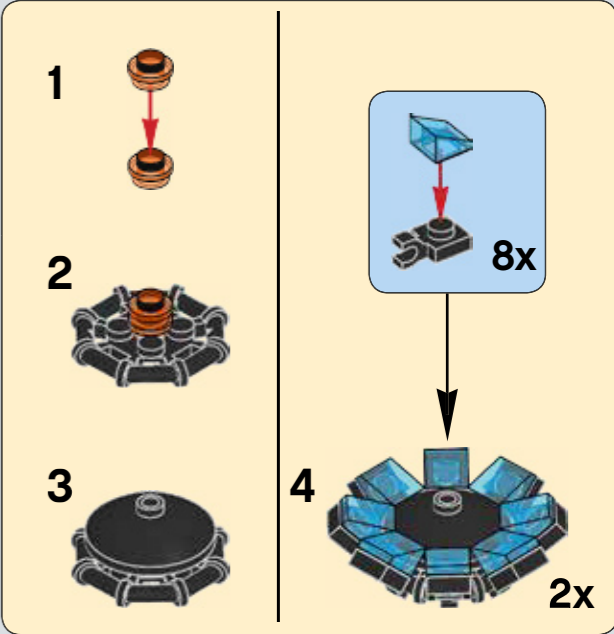
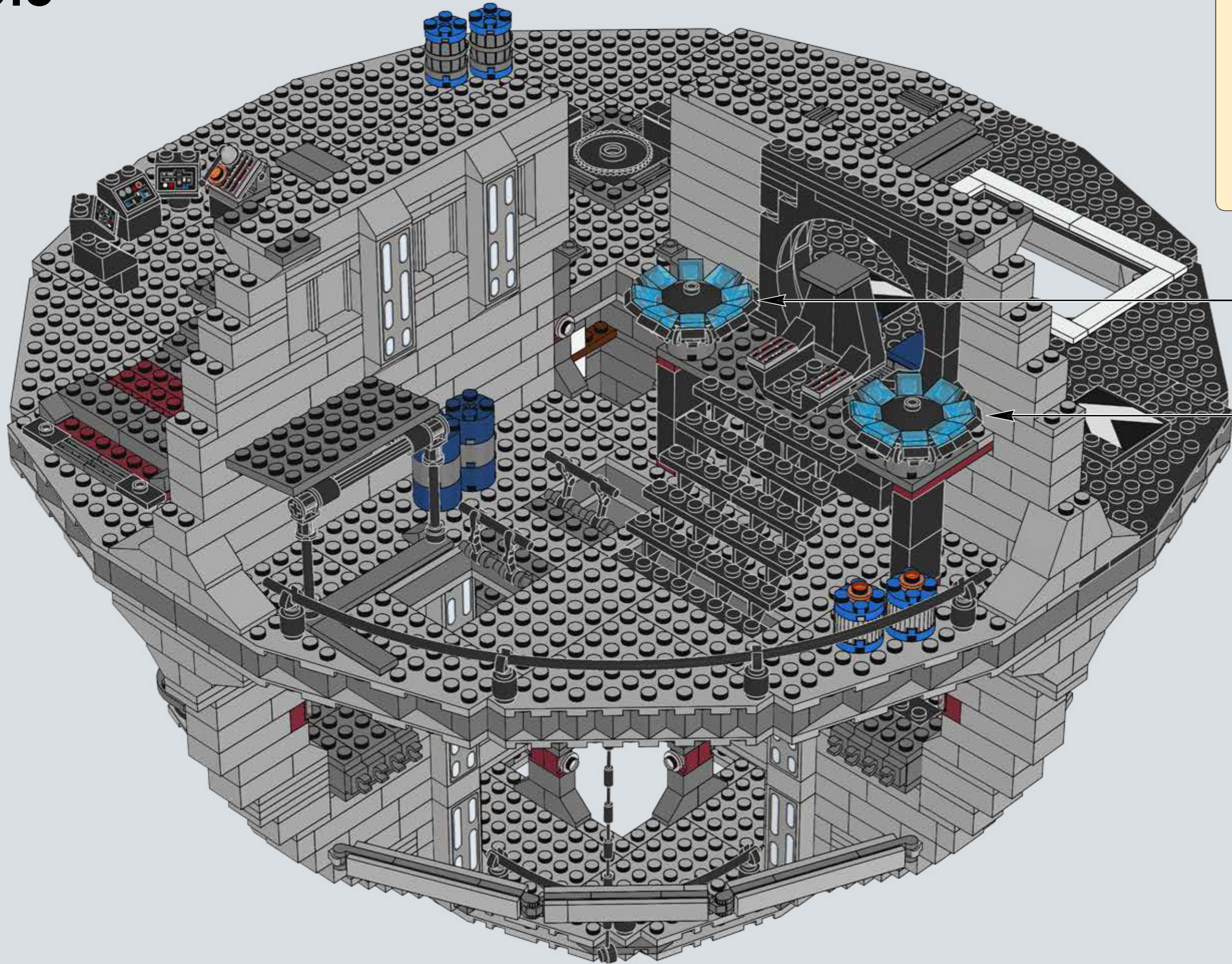

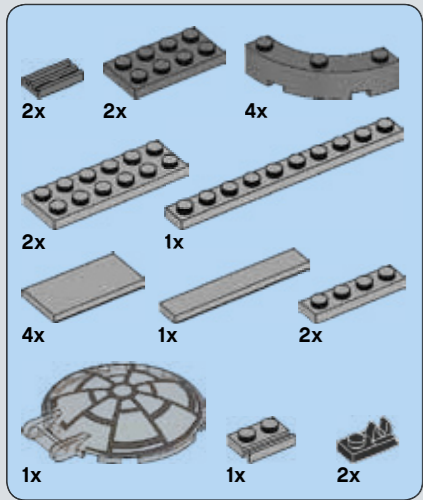

# 316

1



2

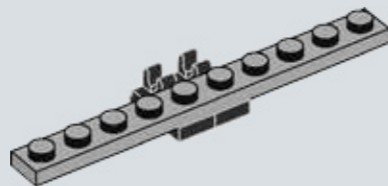

3

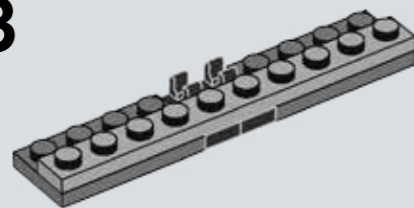

4

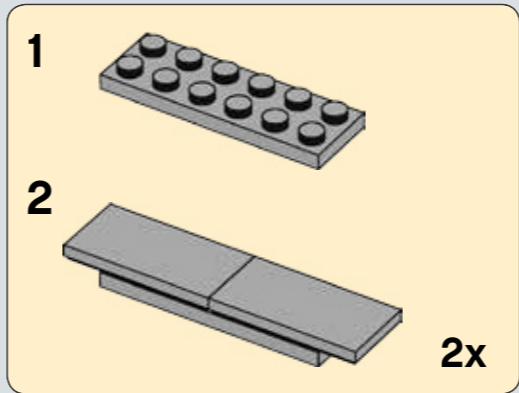
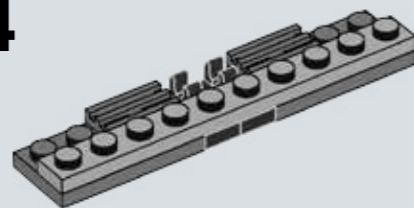

5

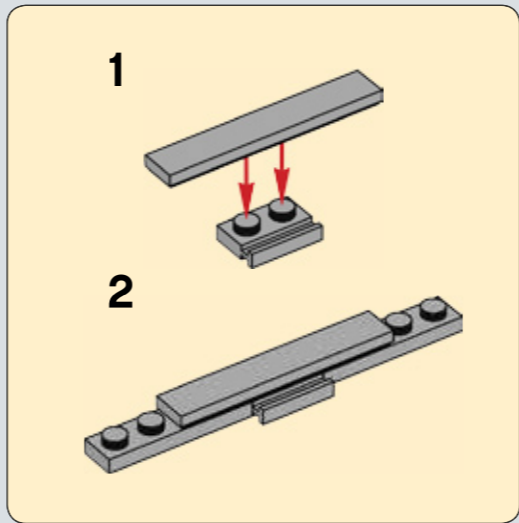
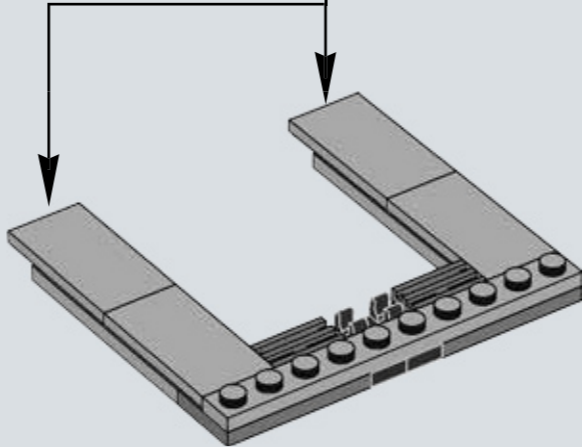

6

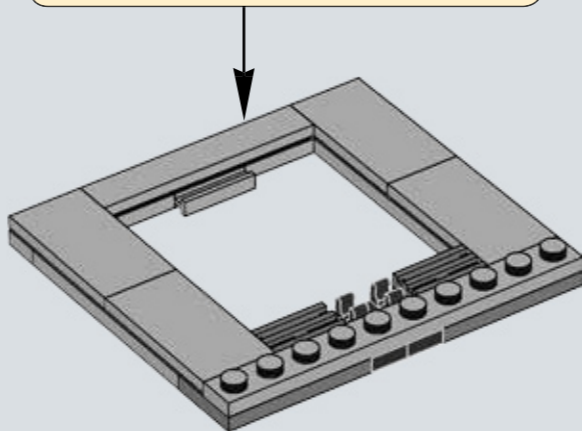

7

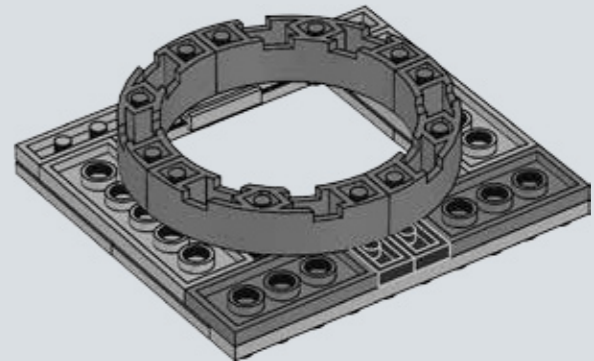

8

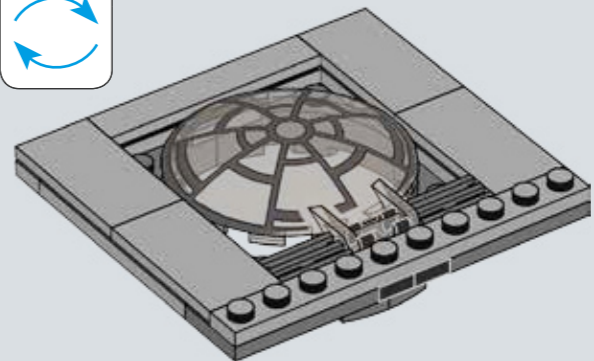
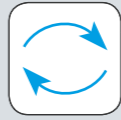



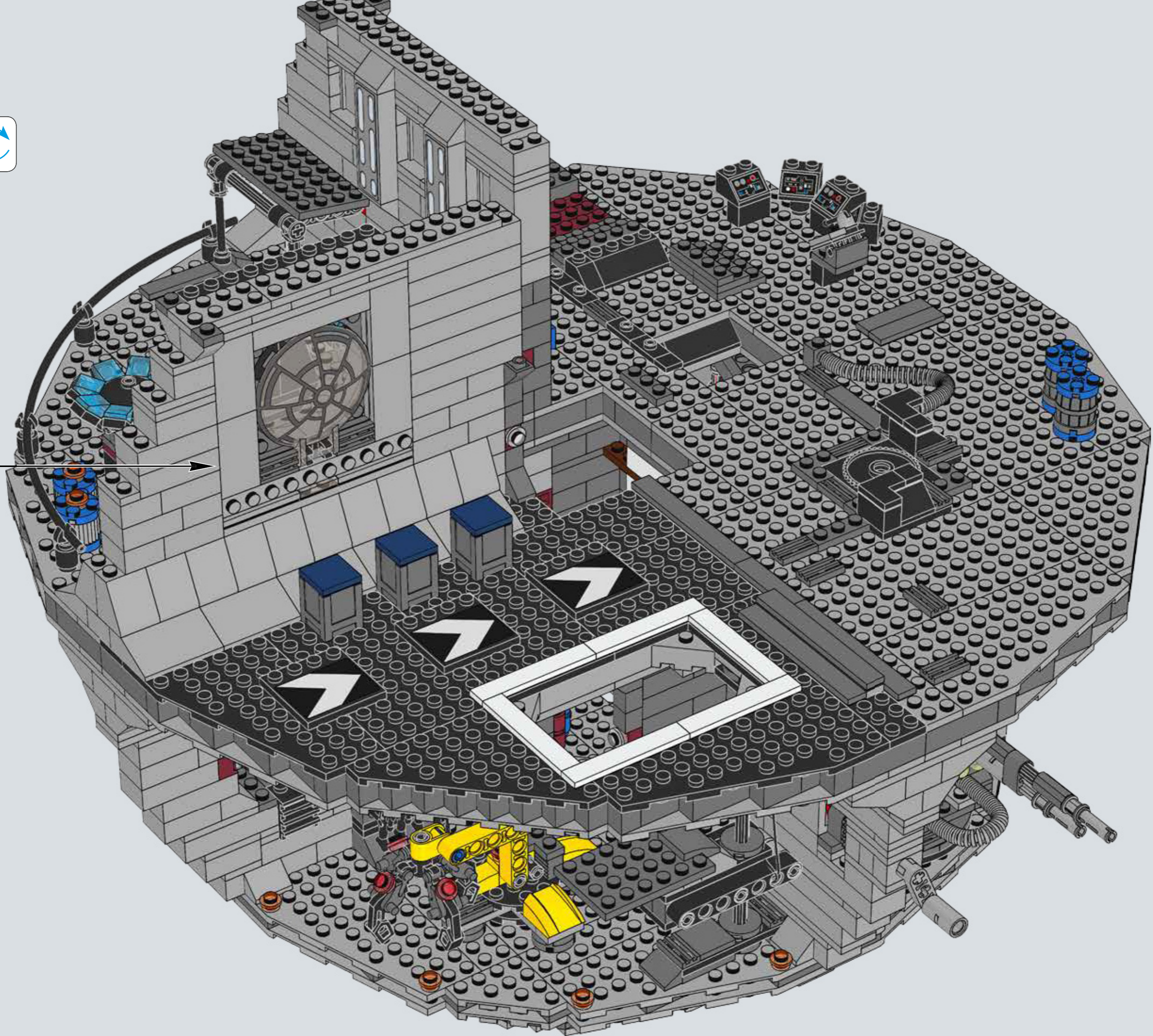

317

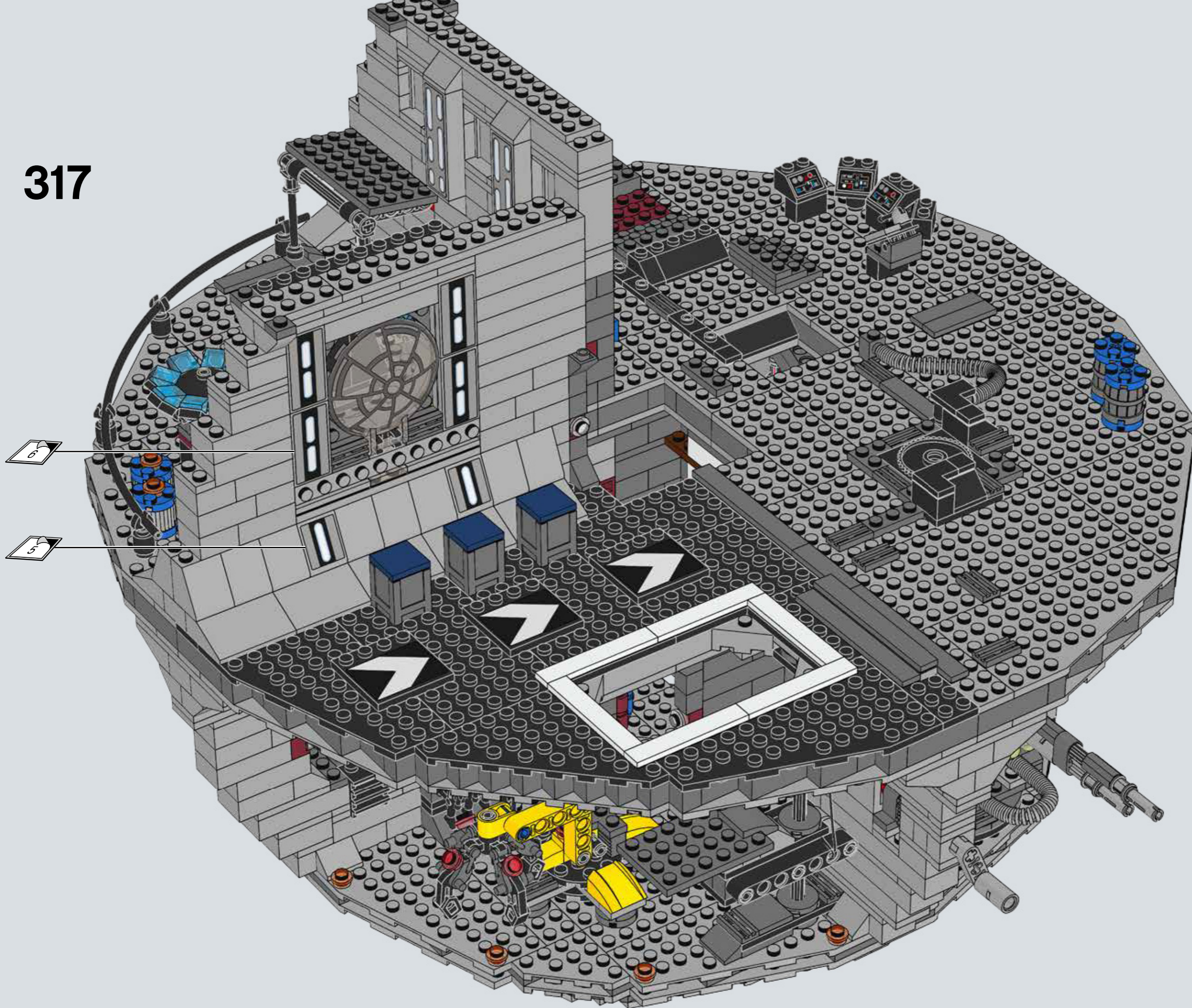

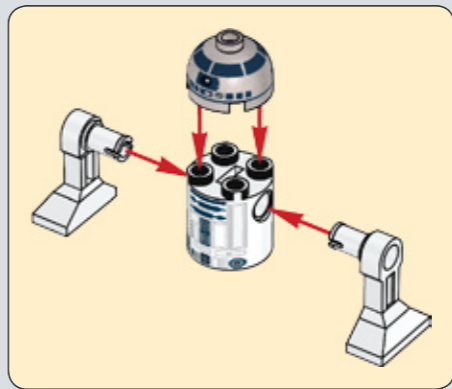
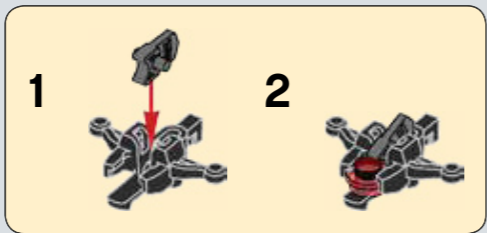
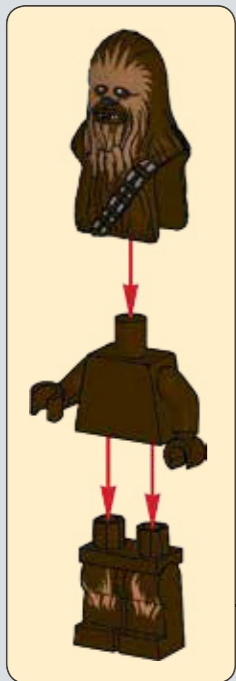
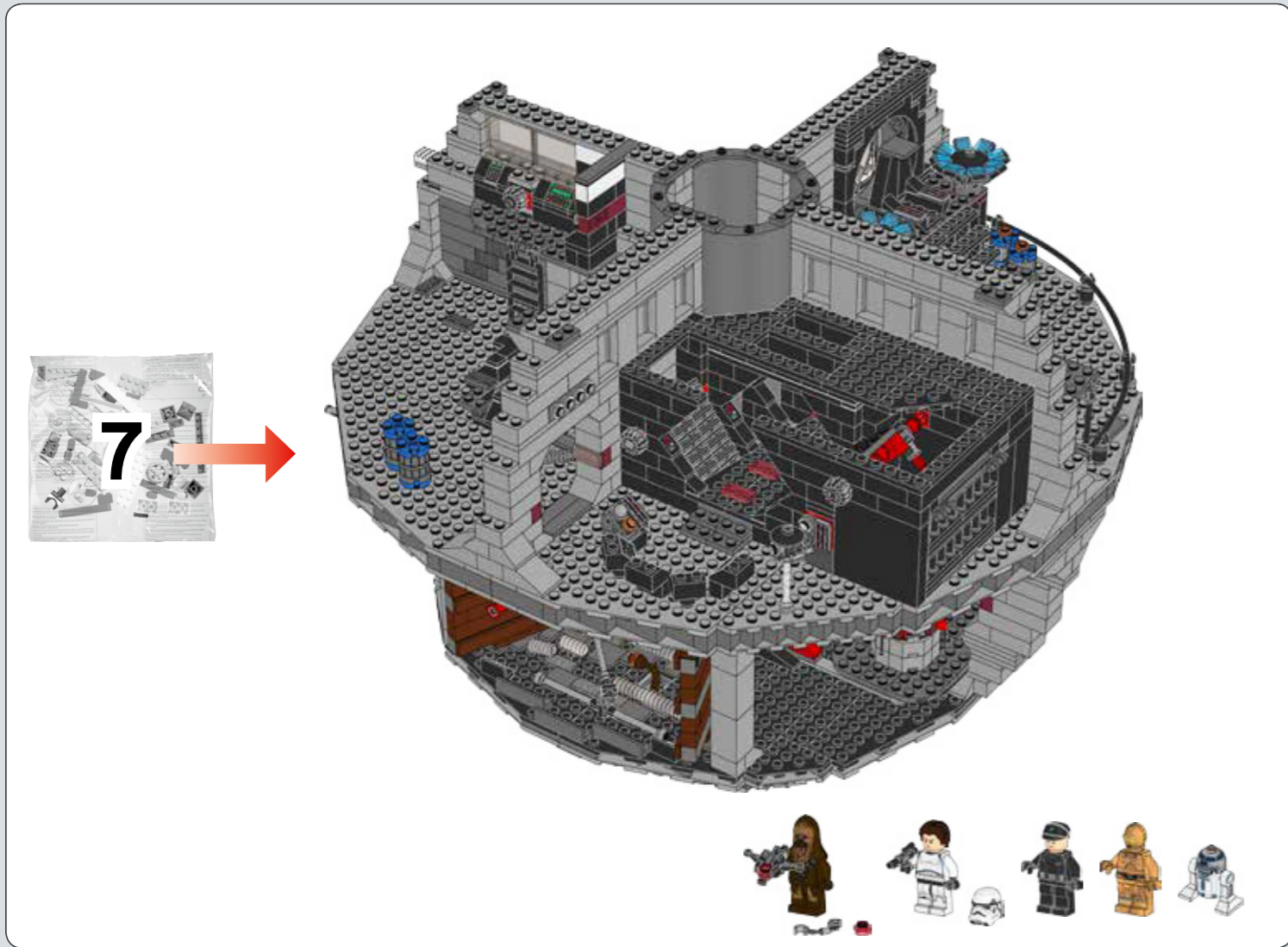

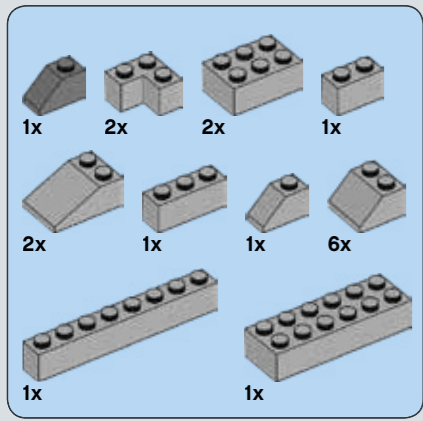

# 318

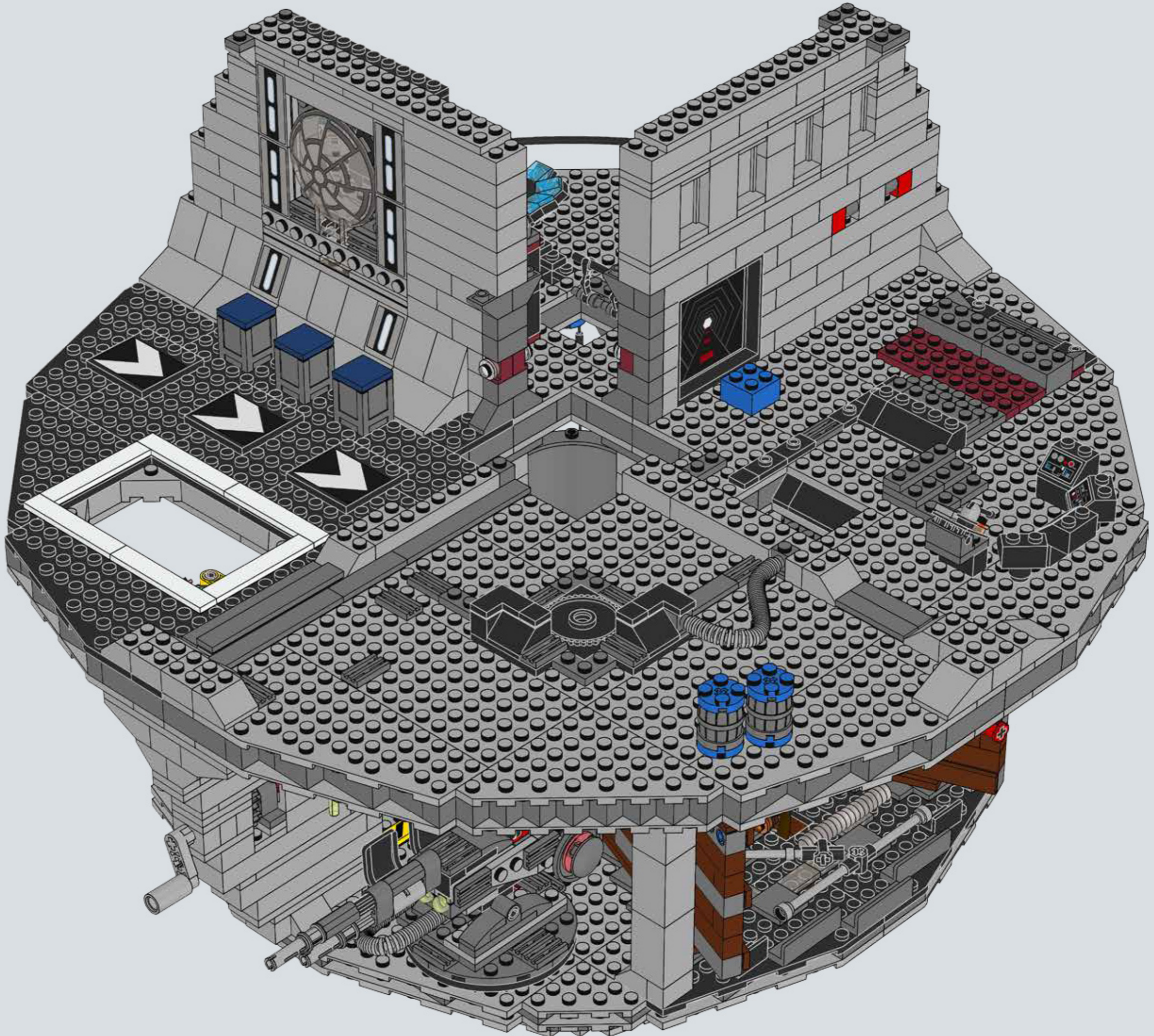

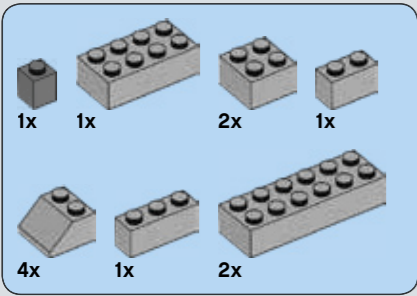

319

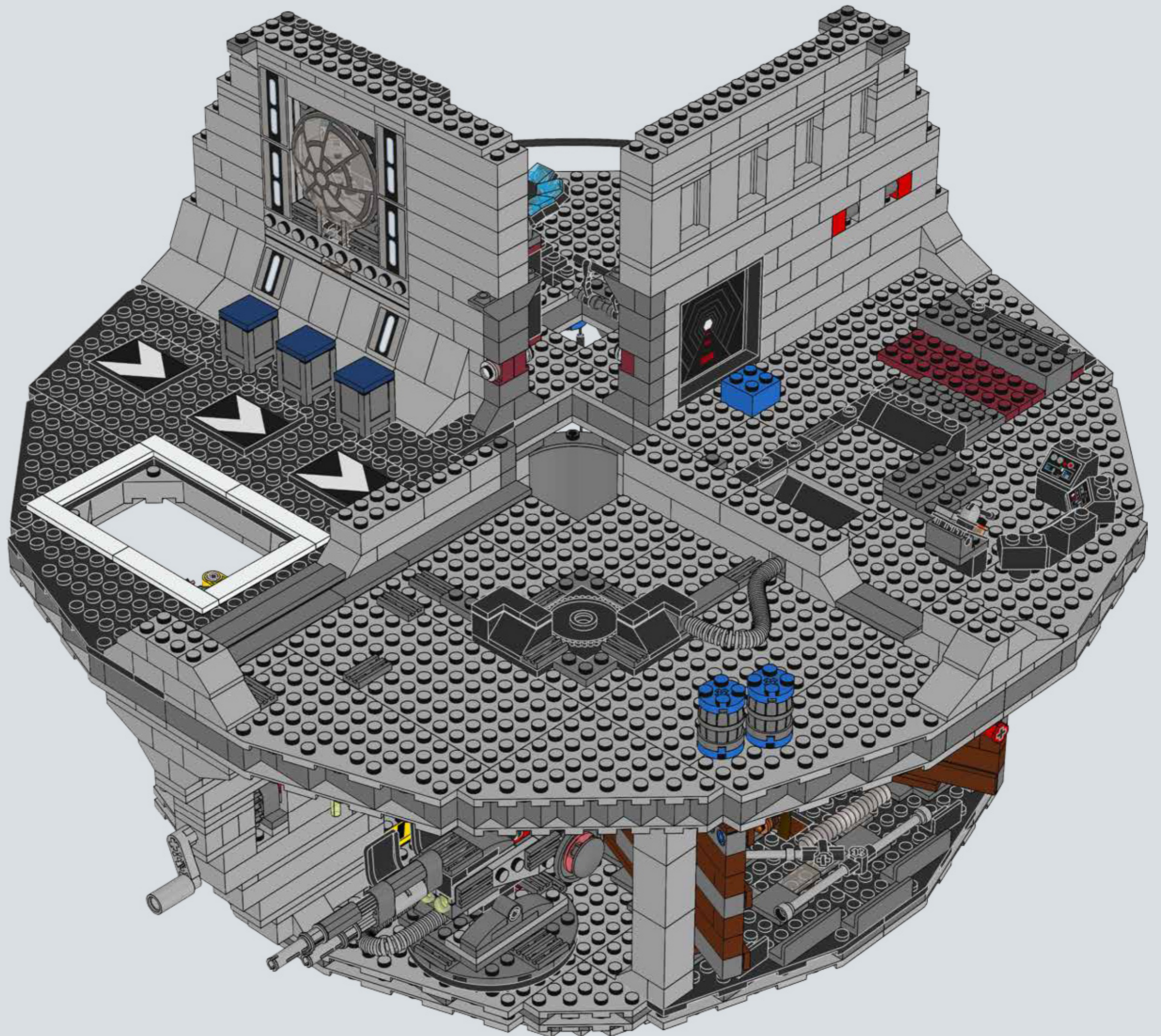

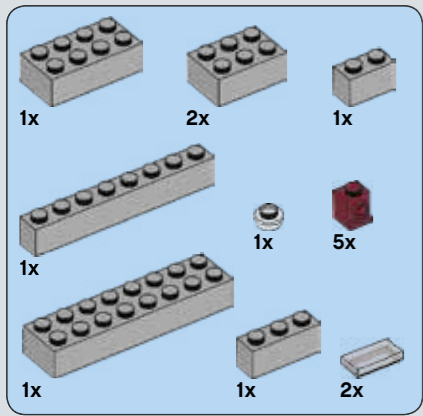

320

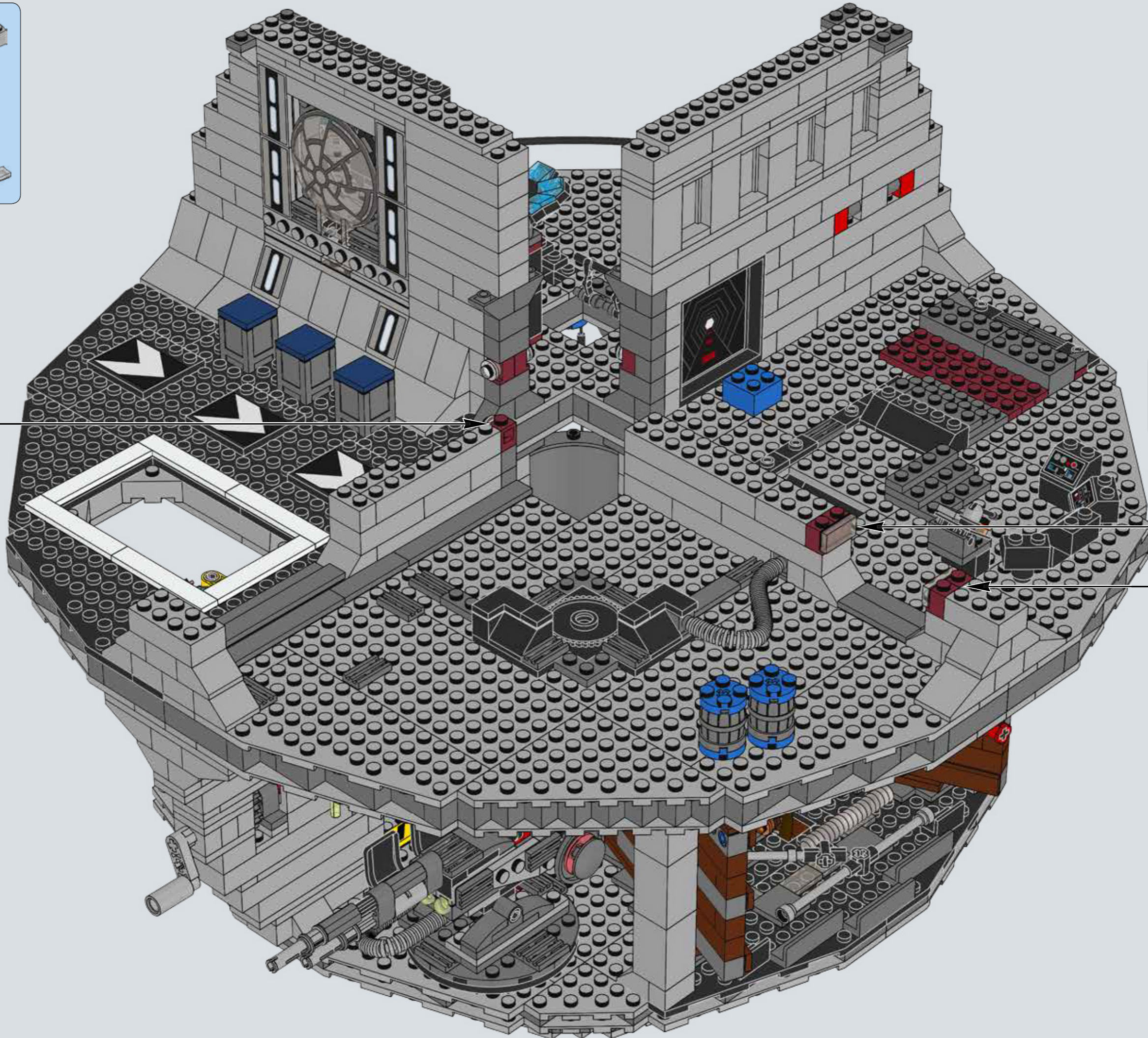
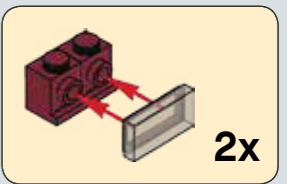
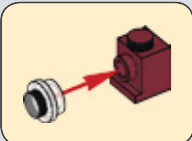

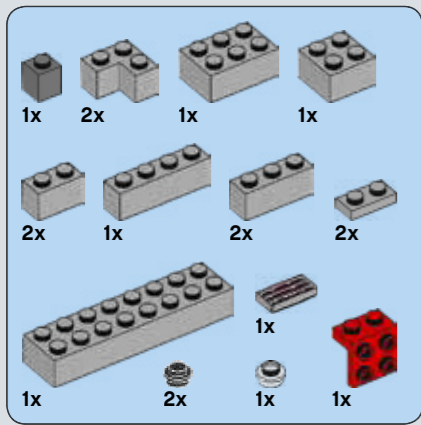

# 321

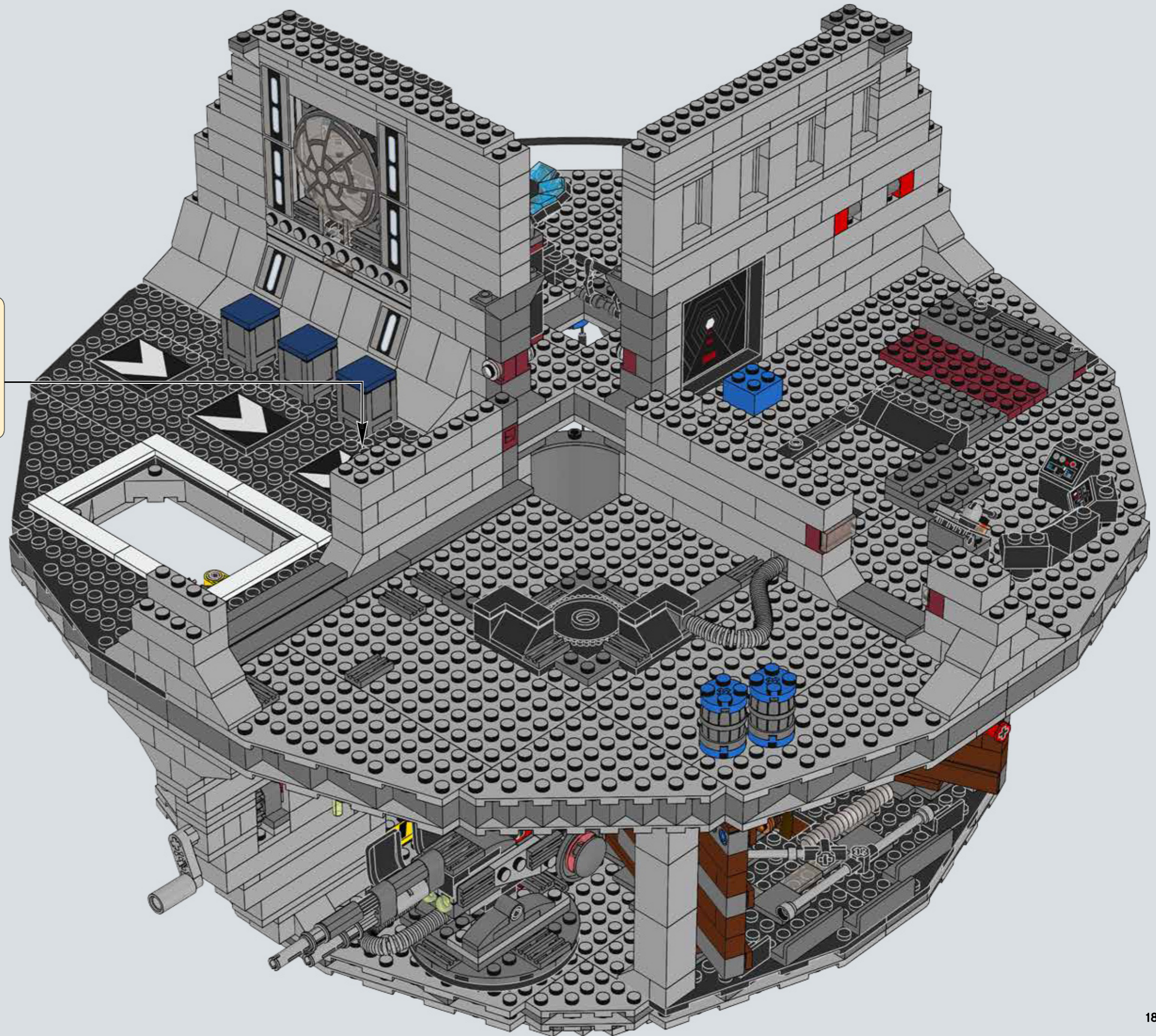
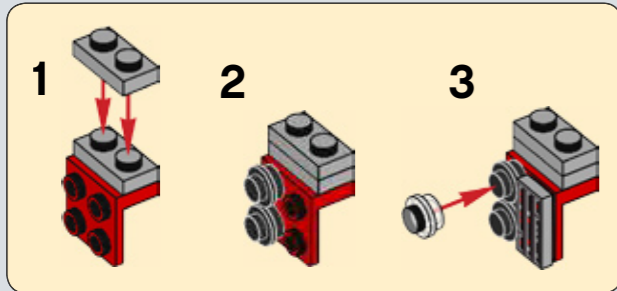

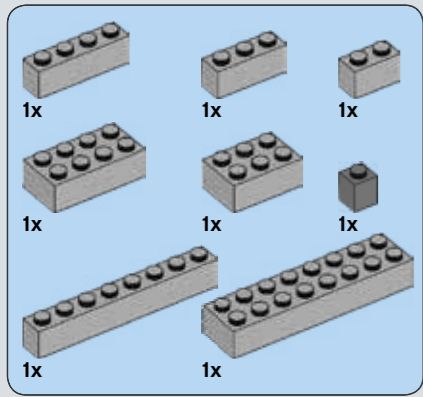

322

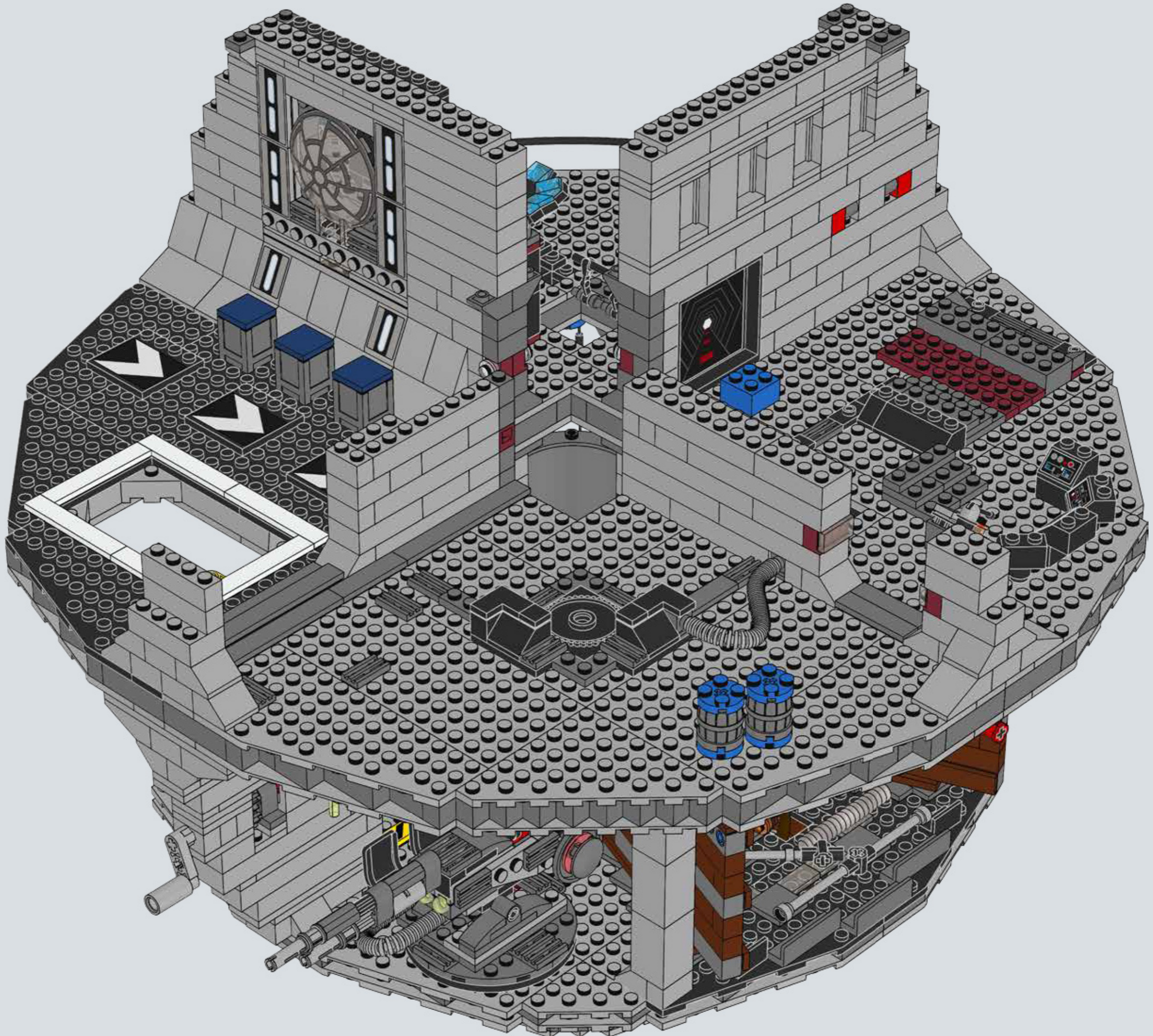



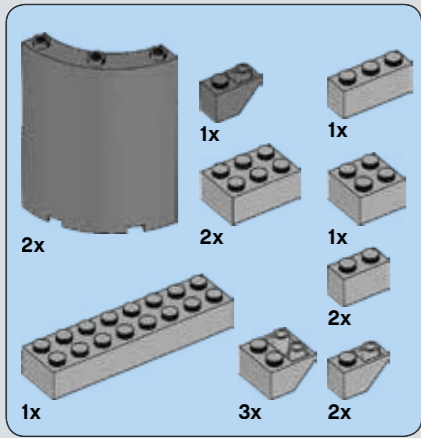

**323**

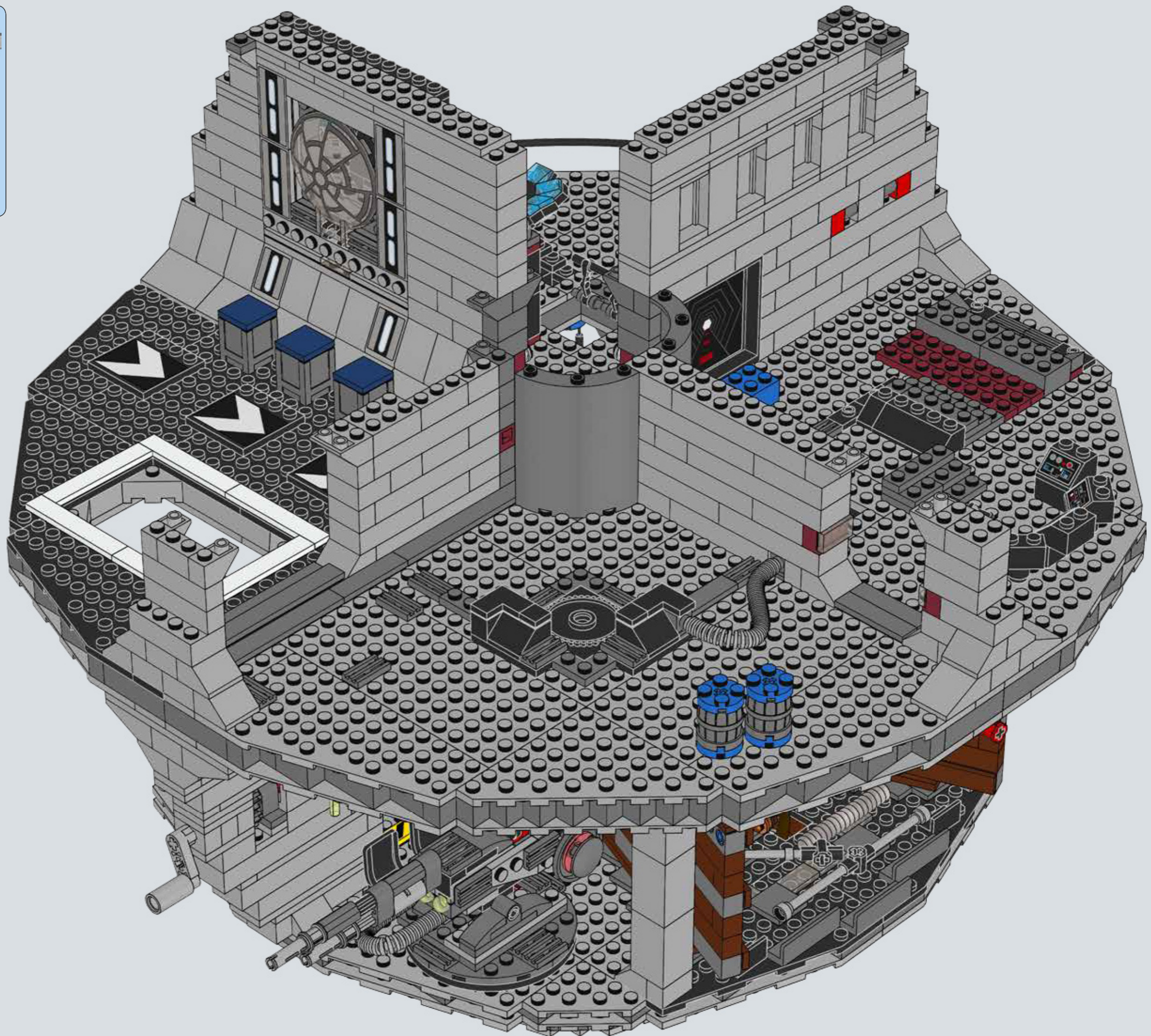

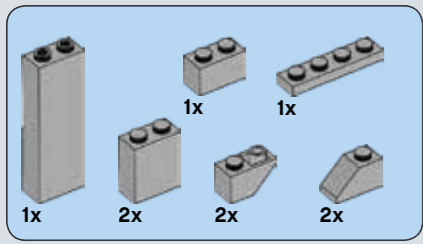

# 324

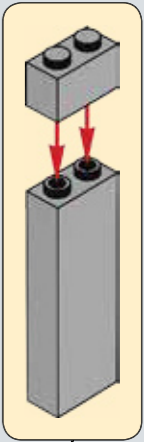
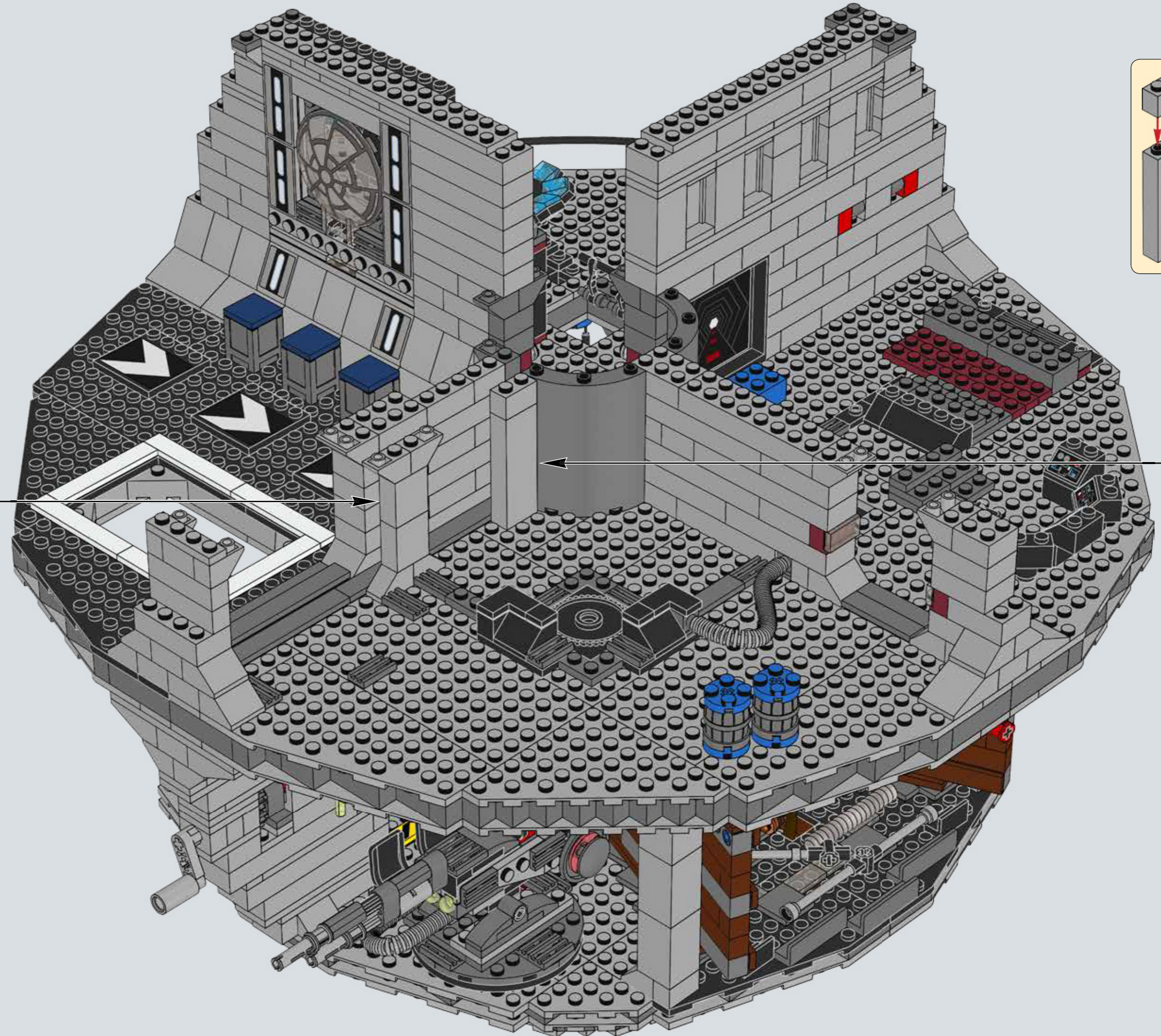
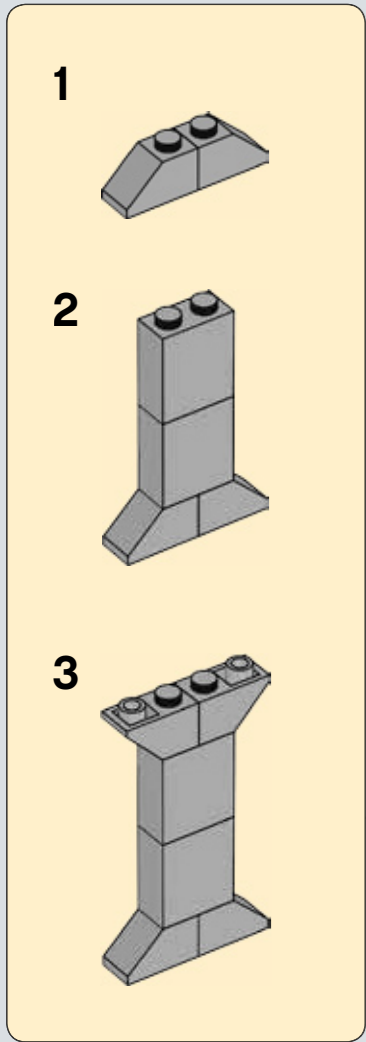

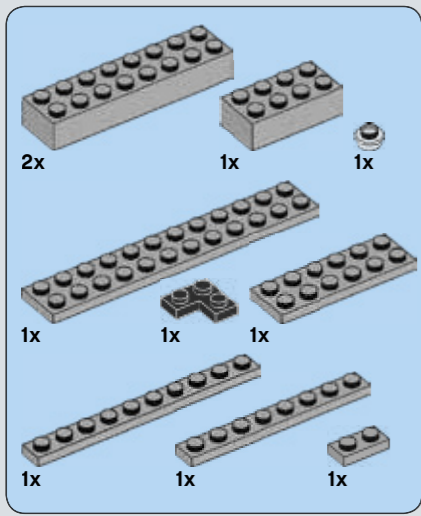

325

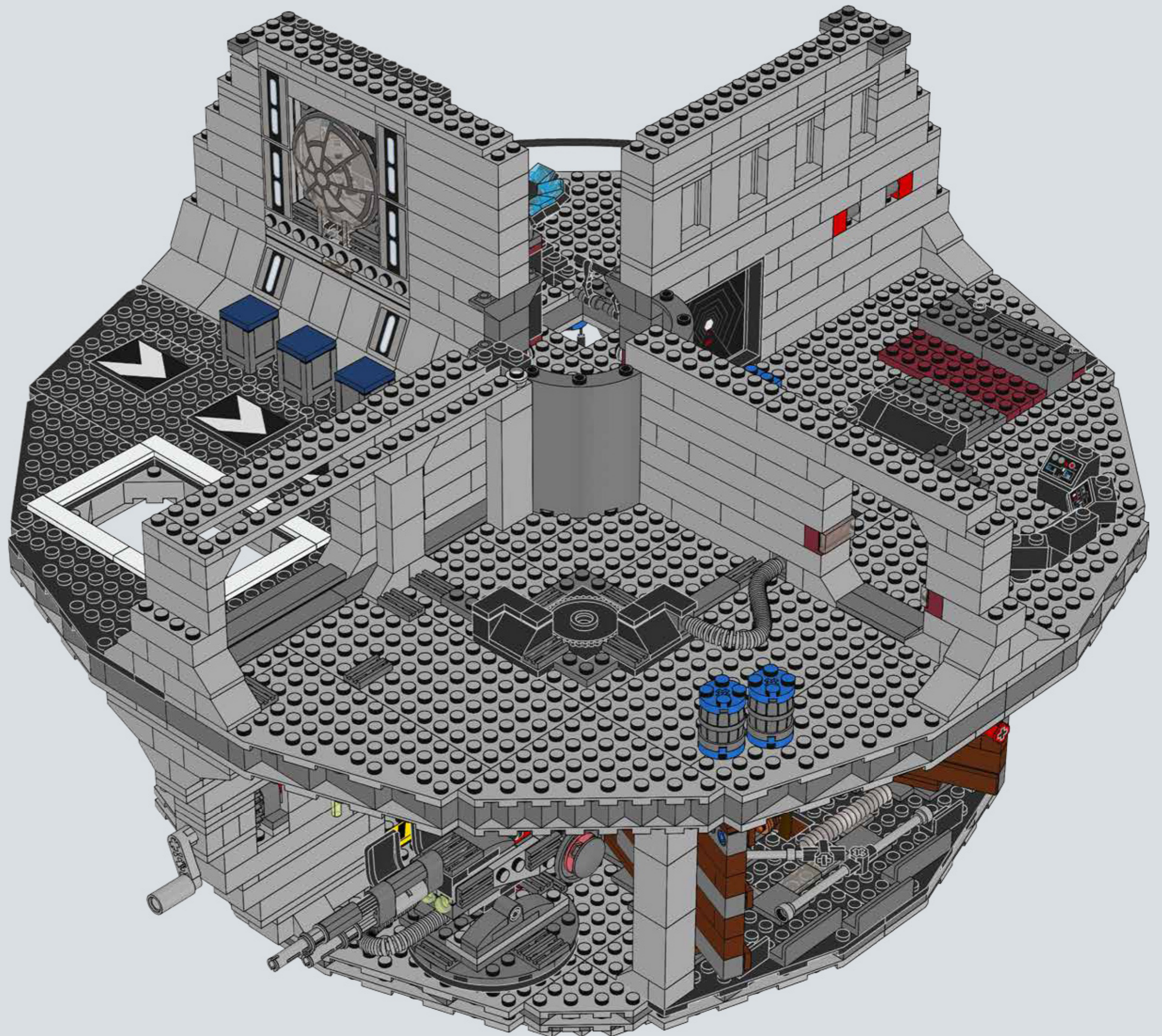

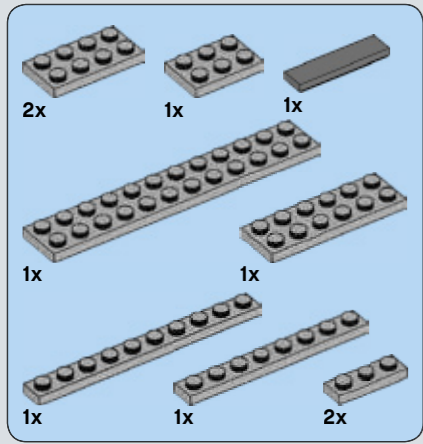

326

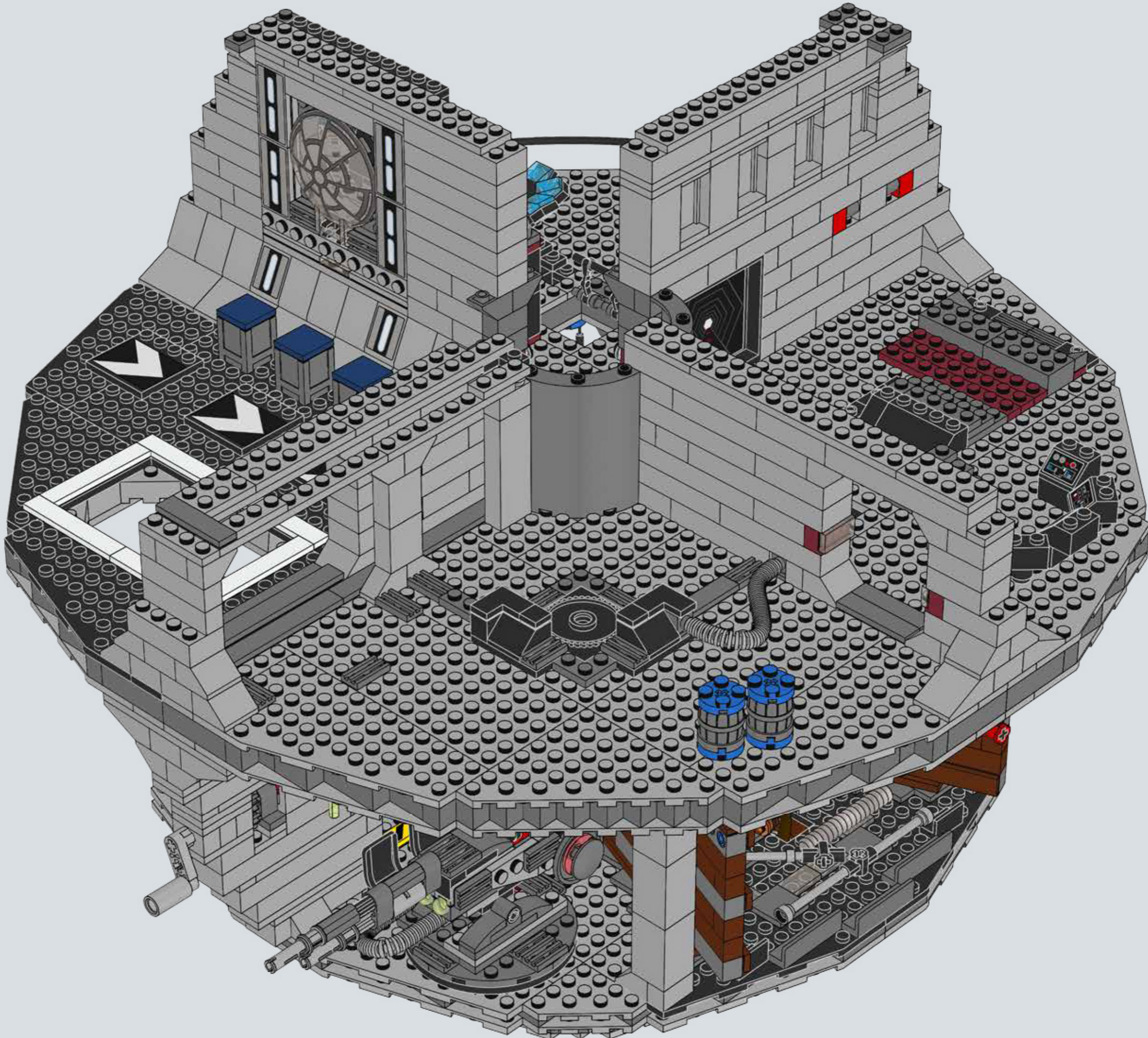

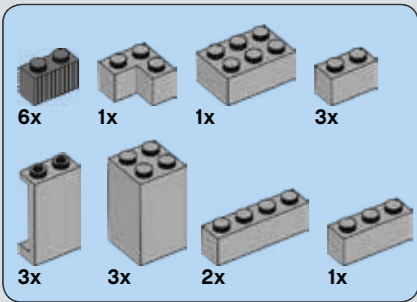

327

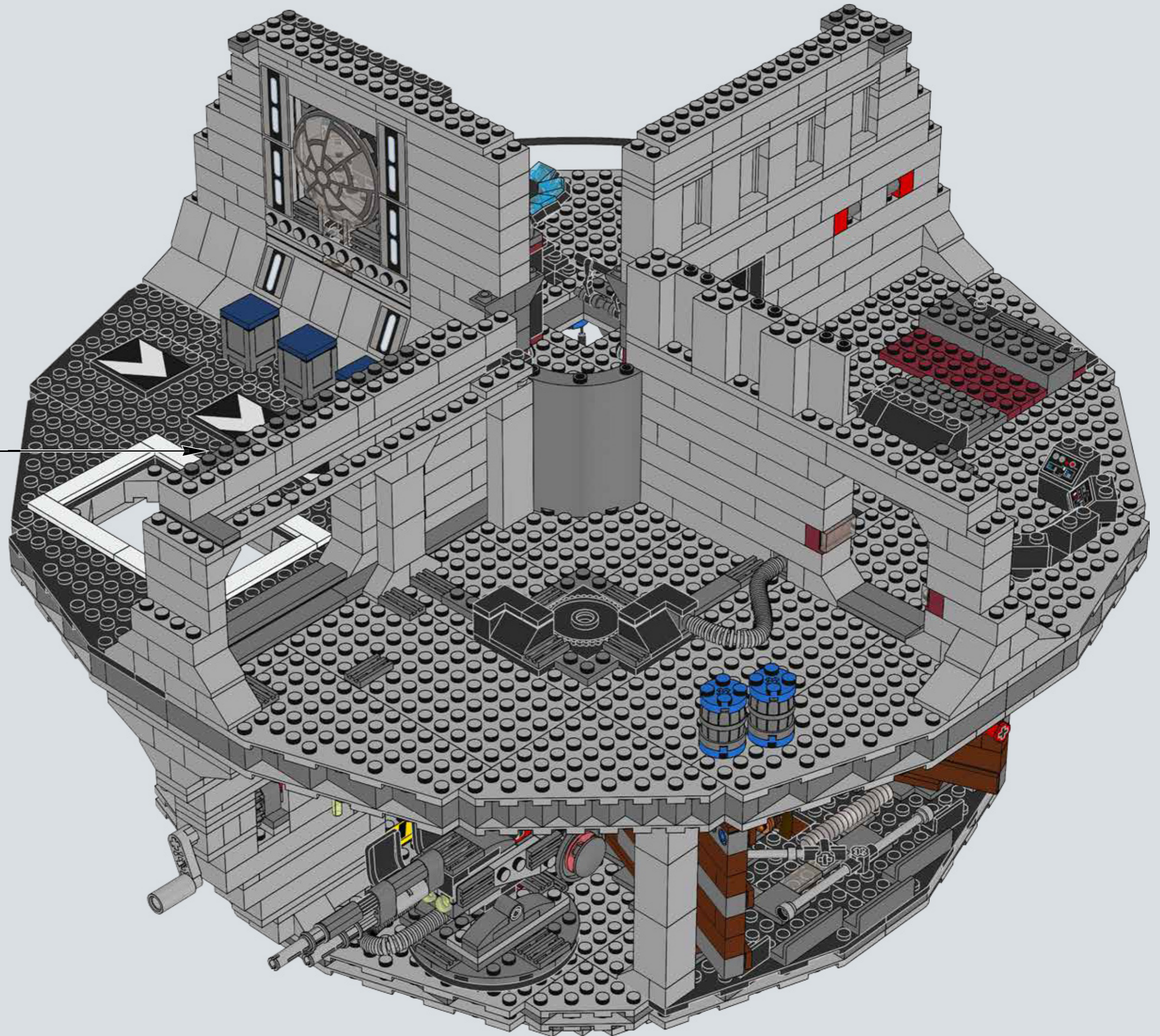

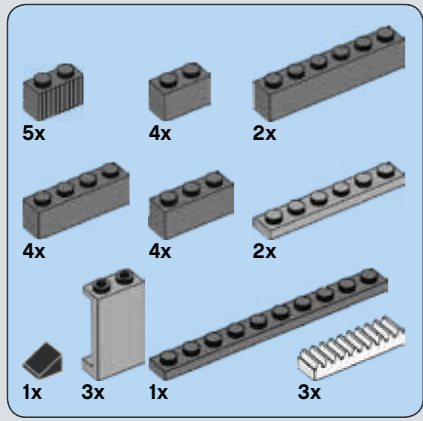

# 328

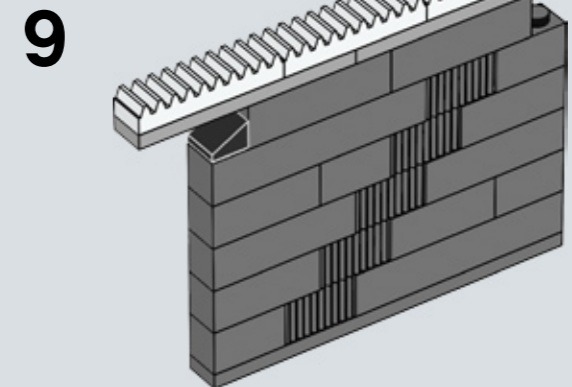
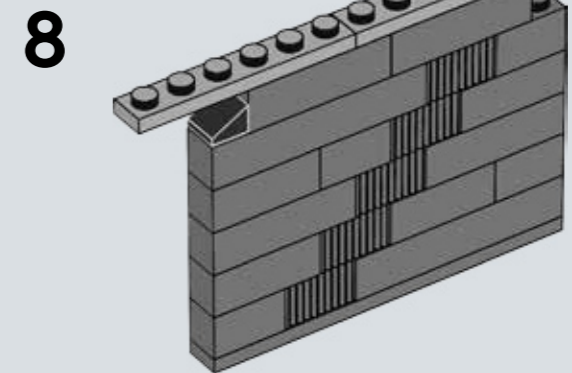
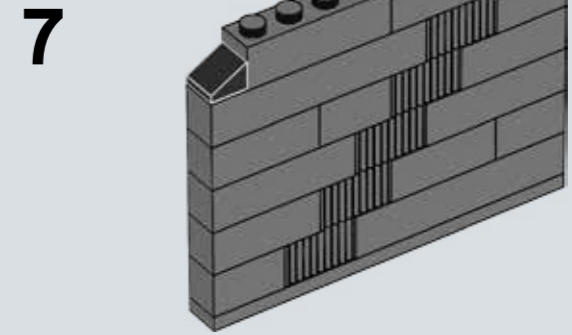
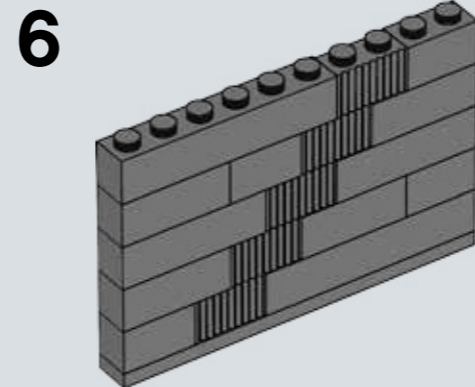
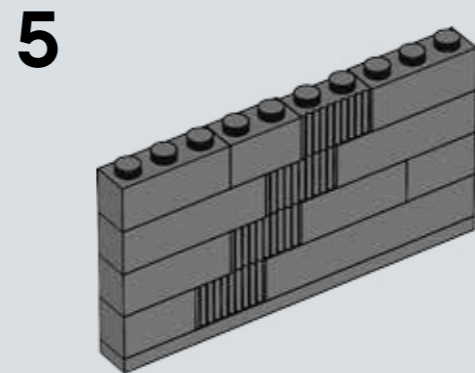
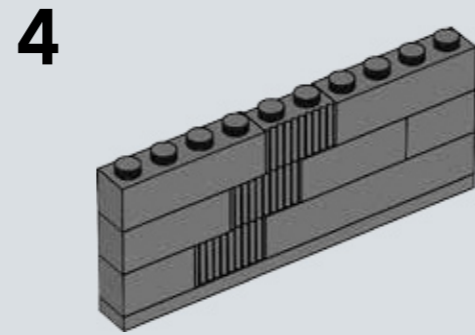
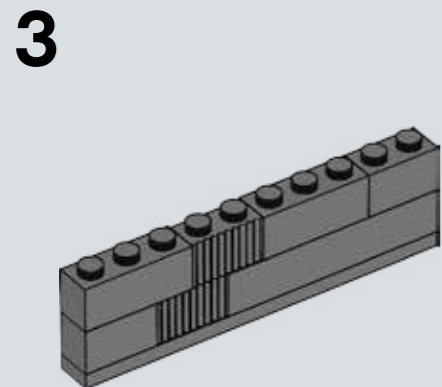
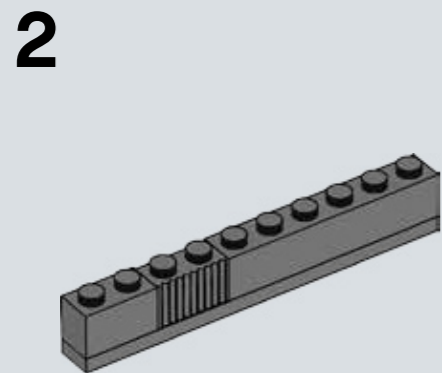
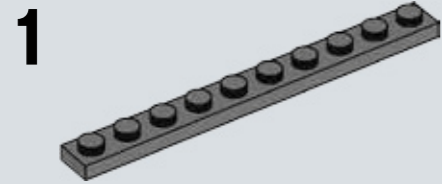

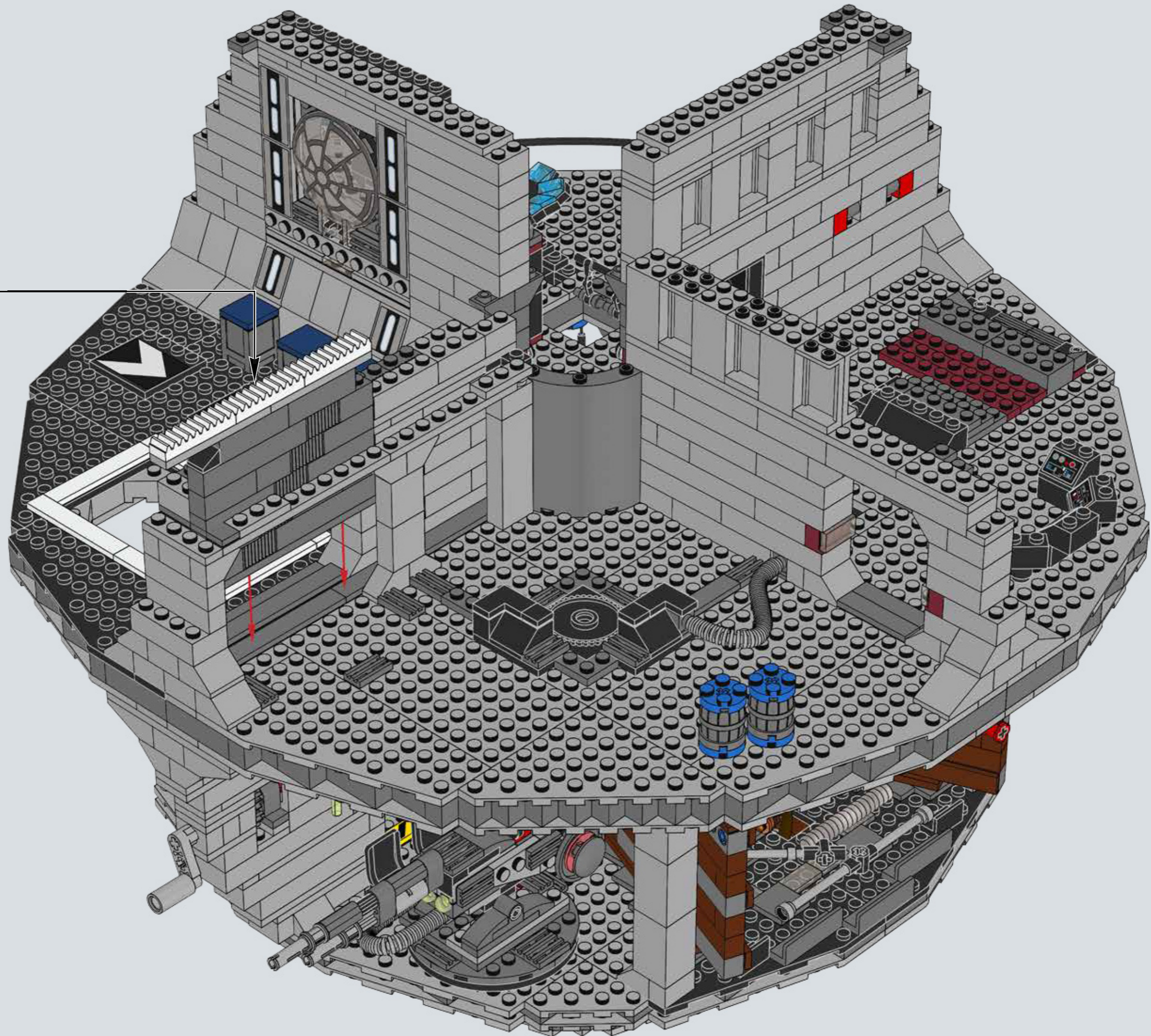

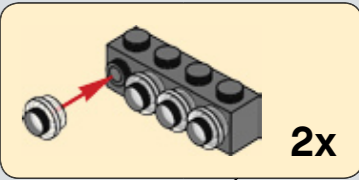
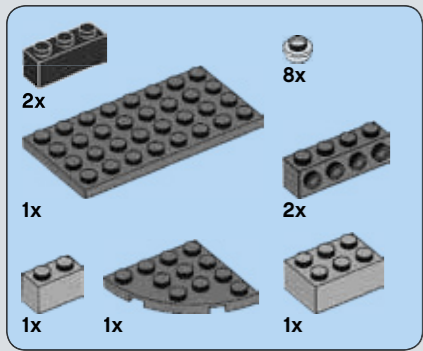

329

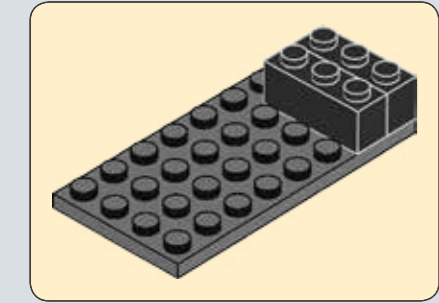
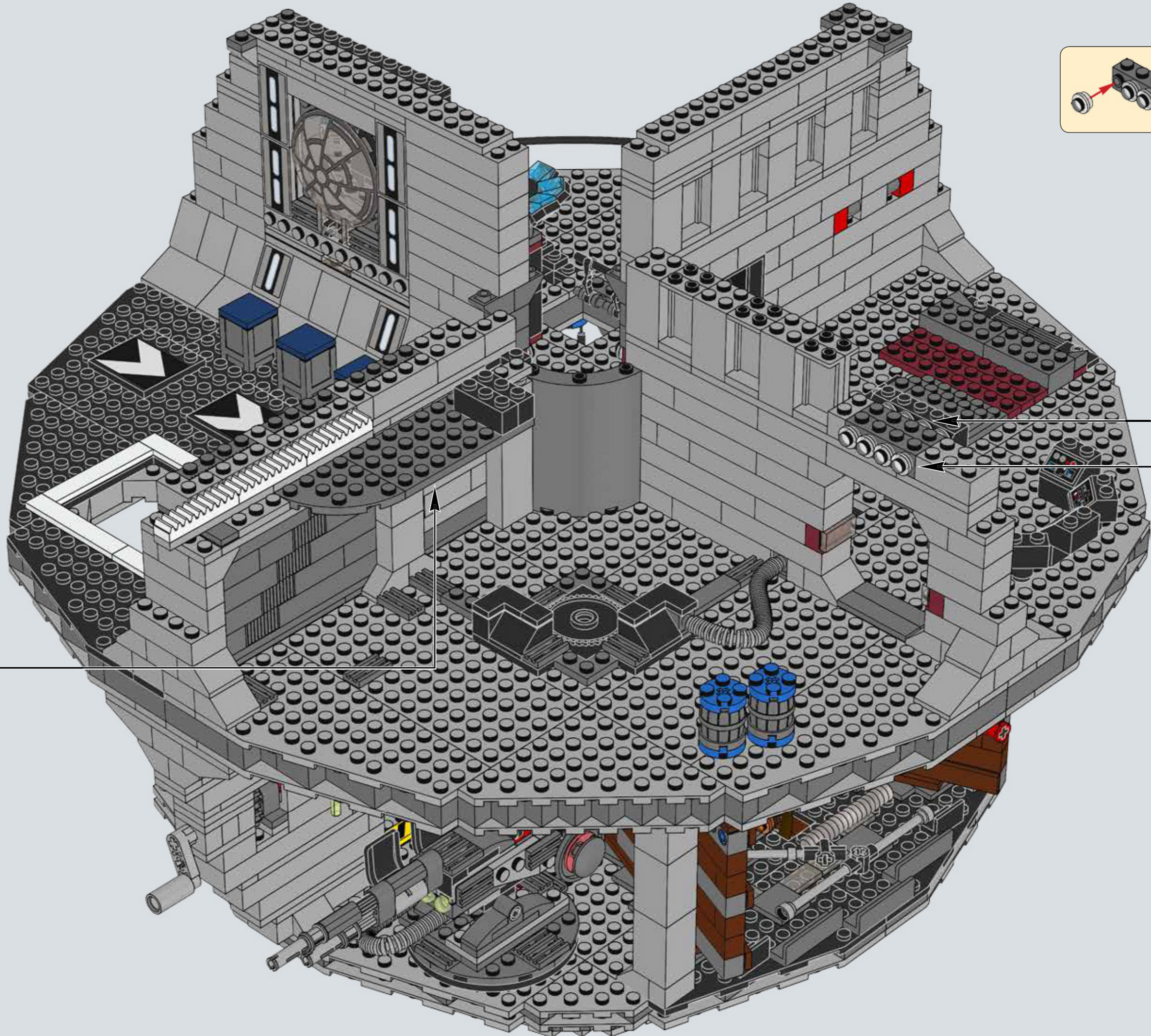



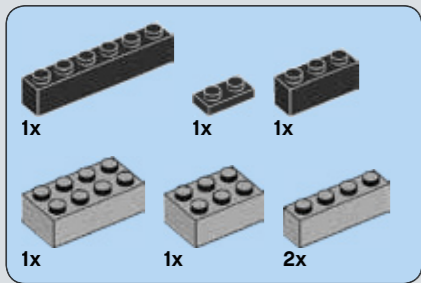

330

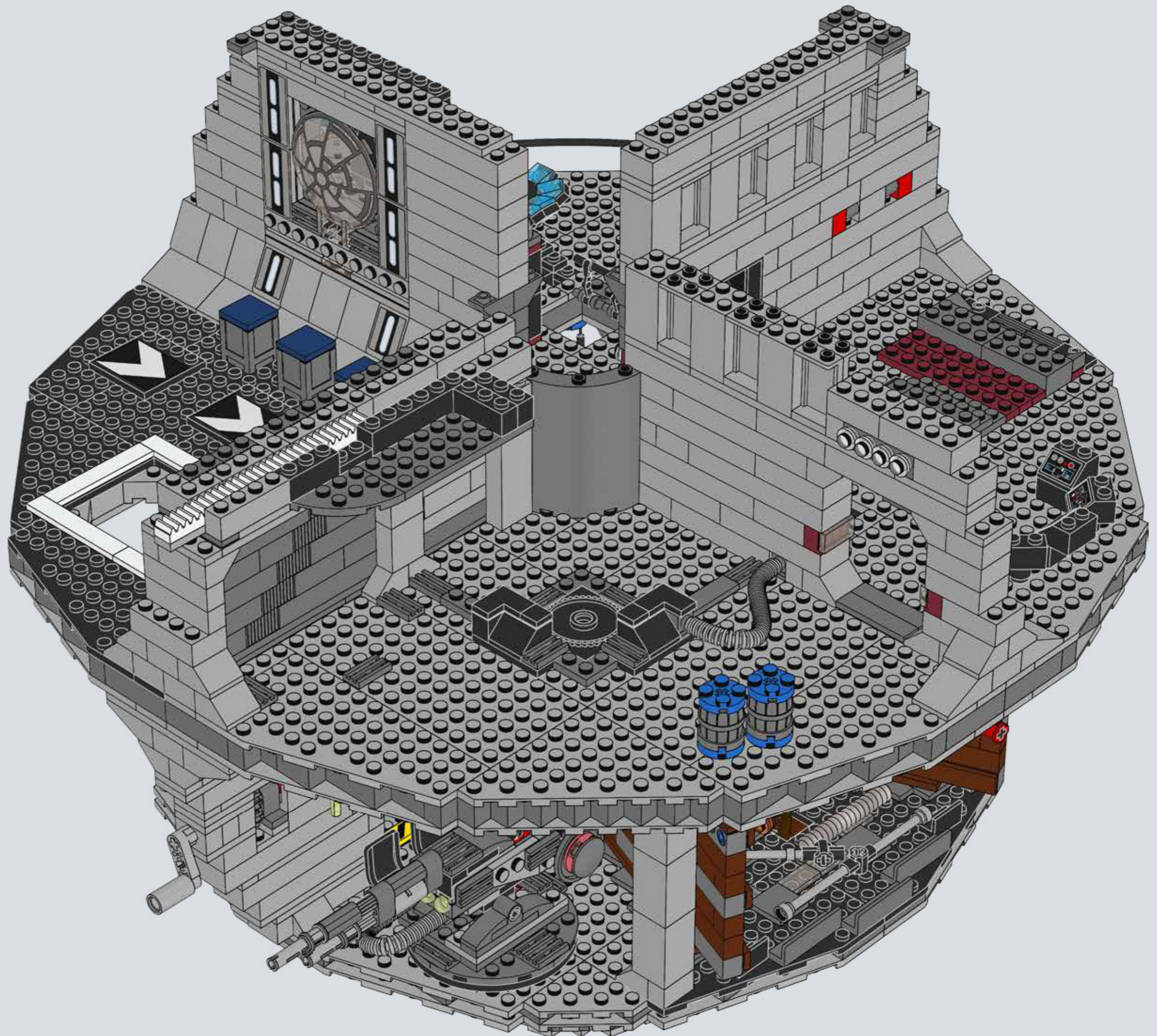

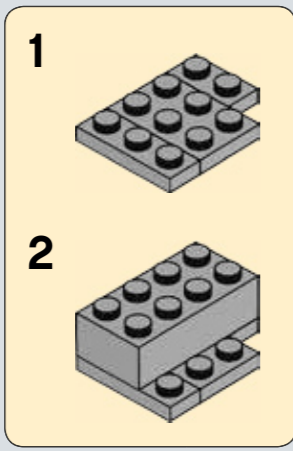
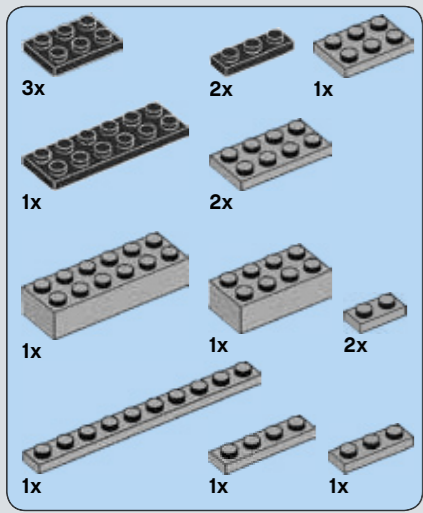

331

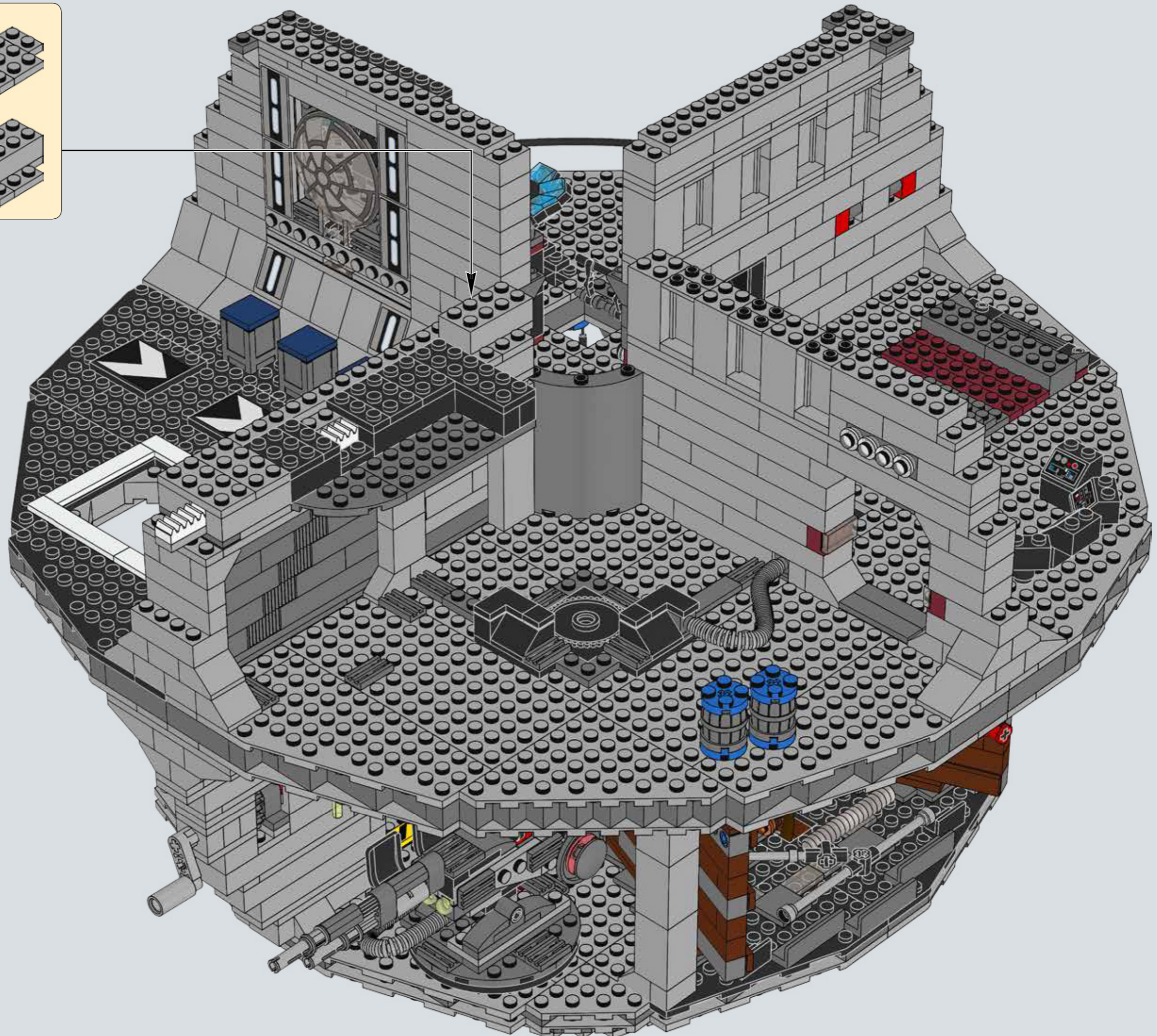

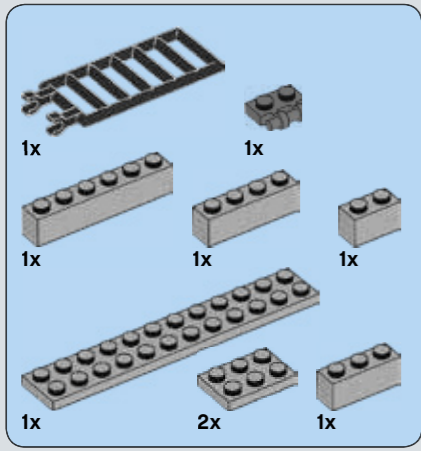

332

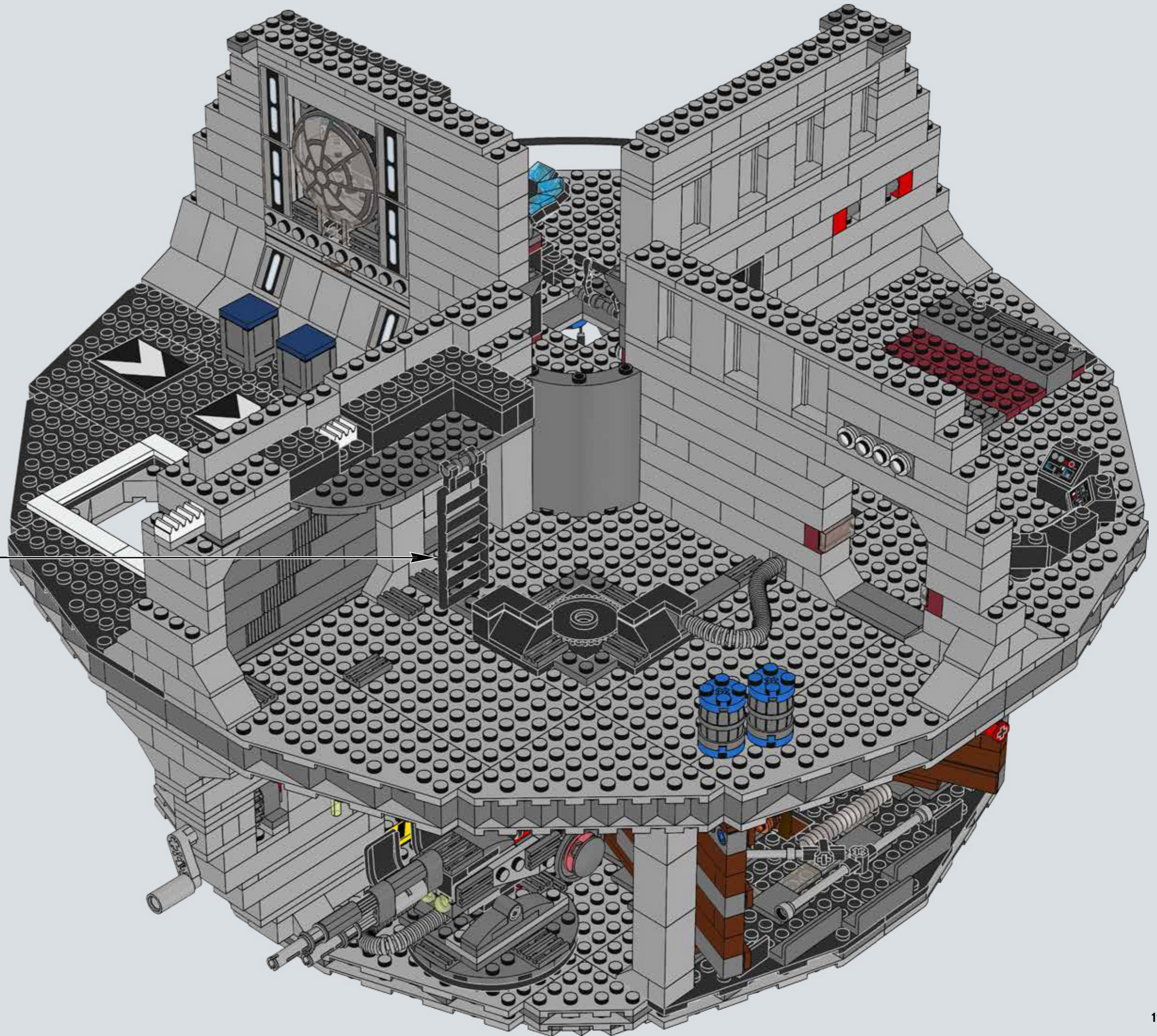
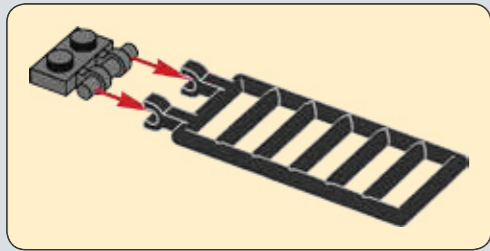





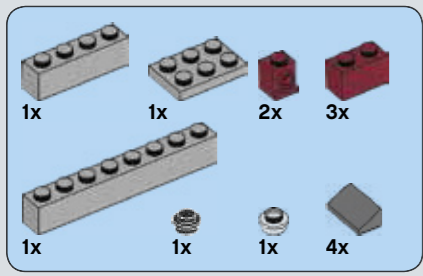

335

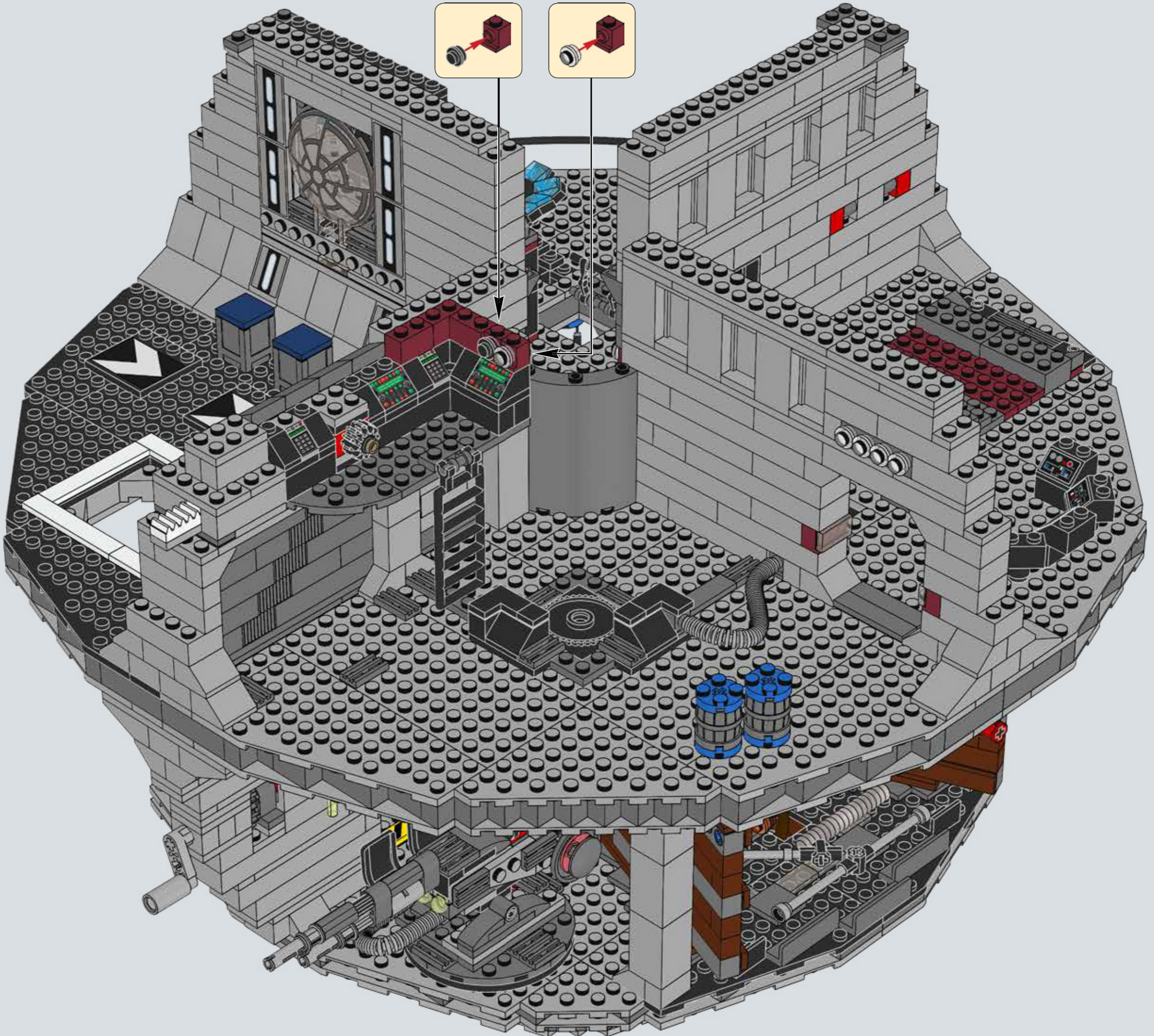

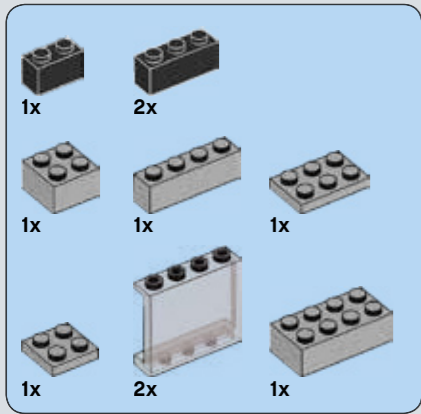

336

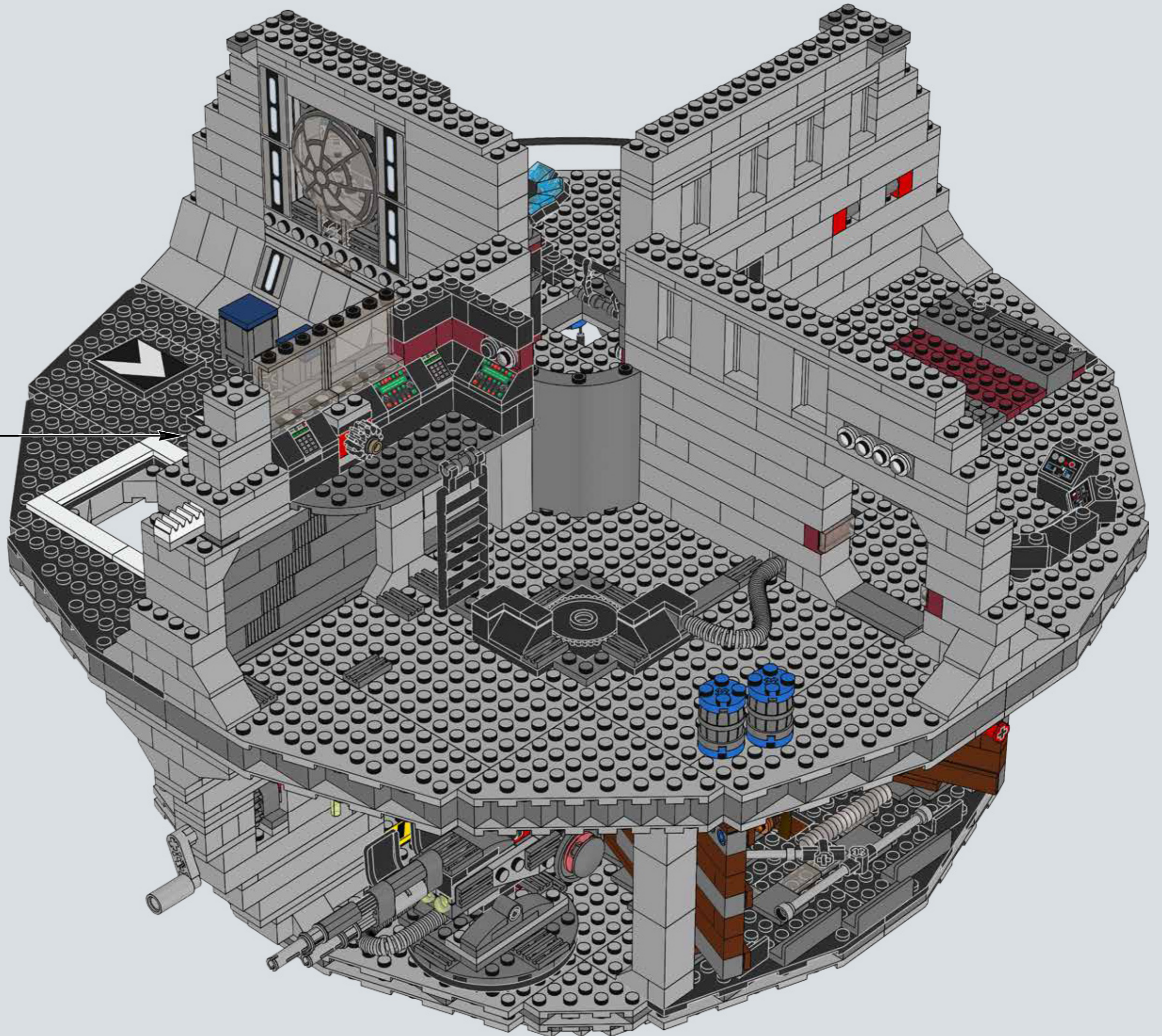
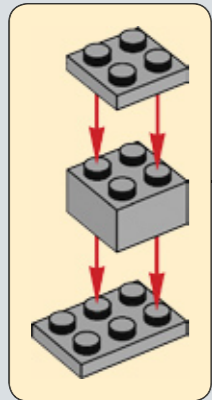

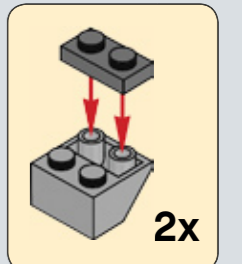
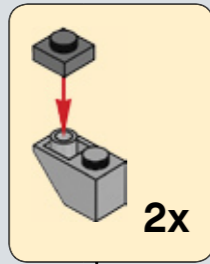
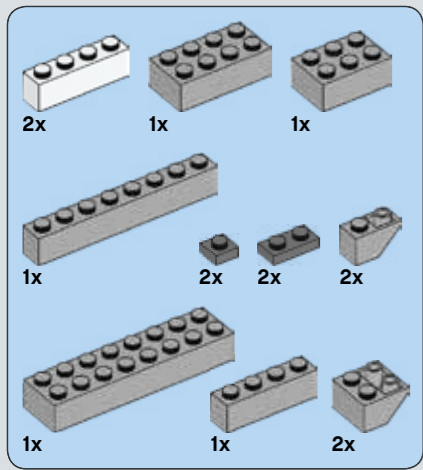

337

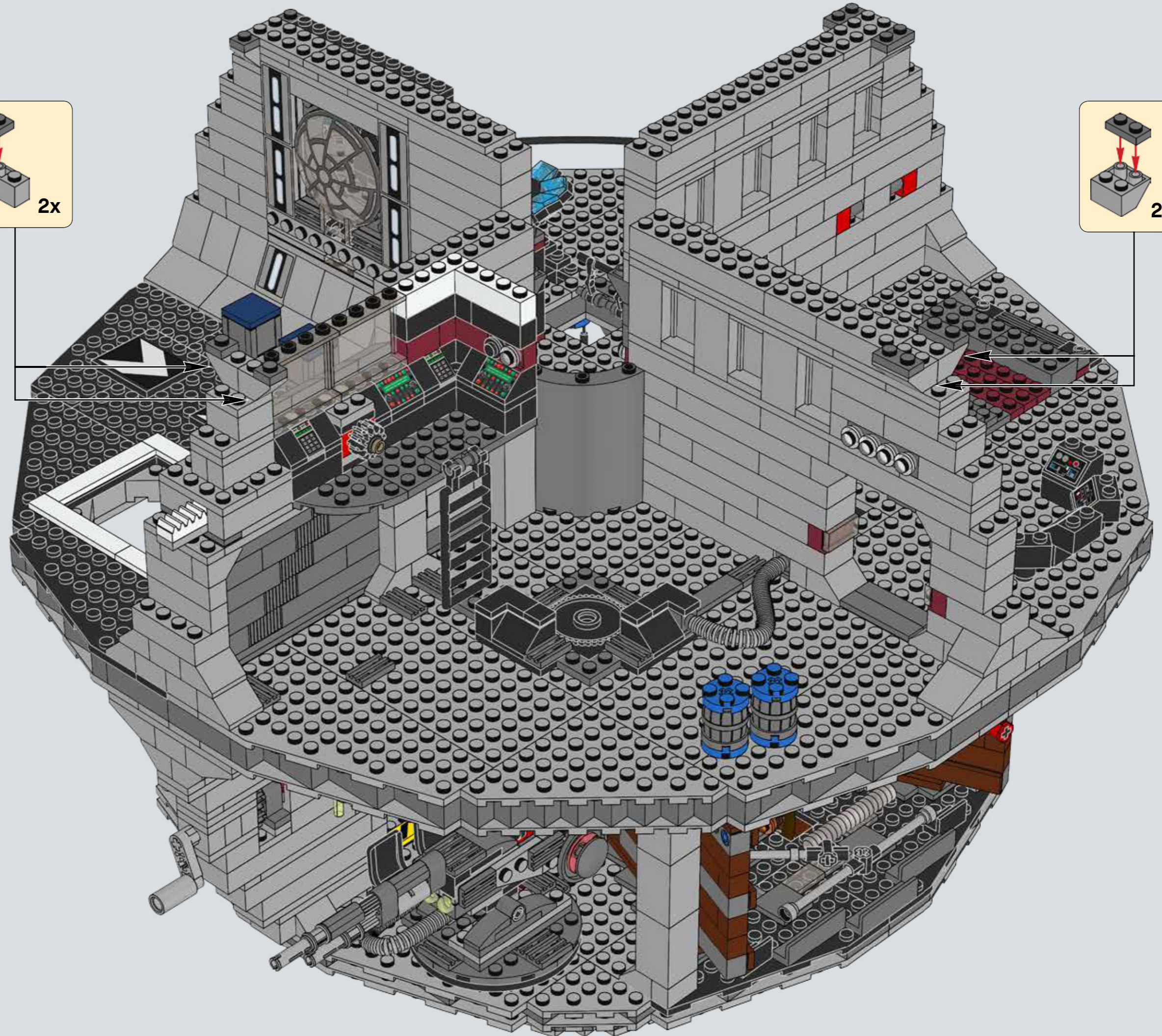



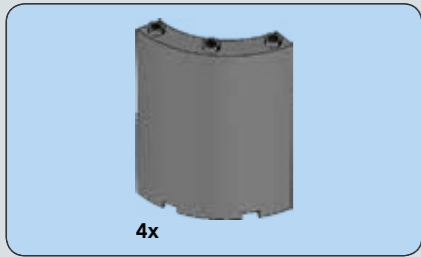

338

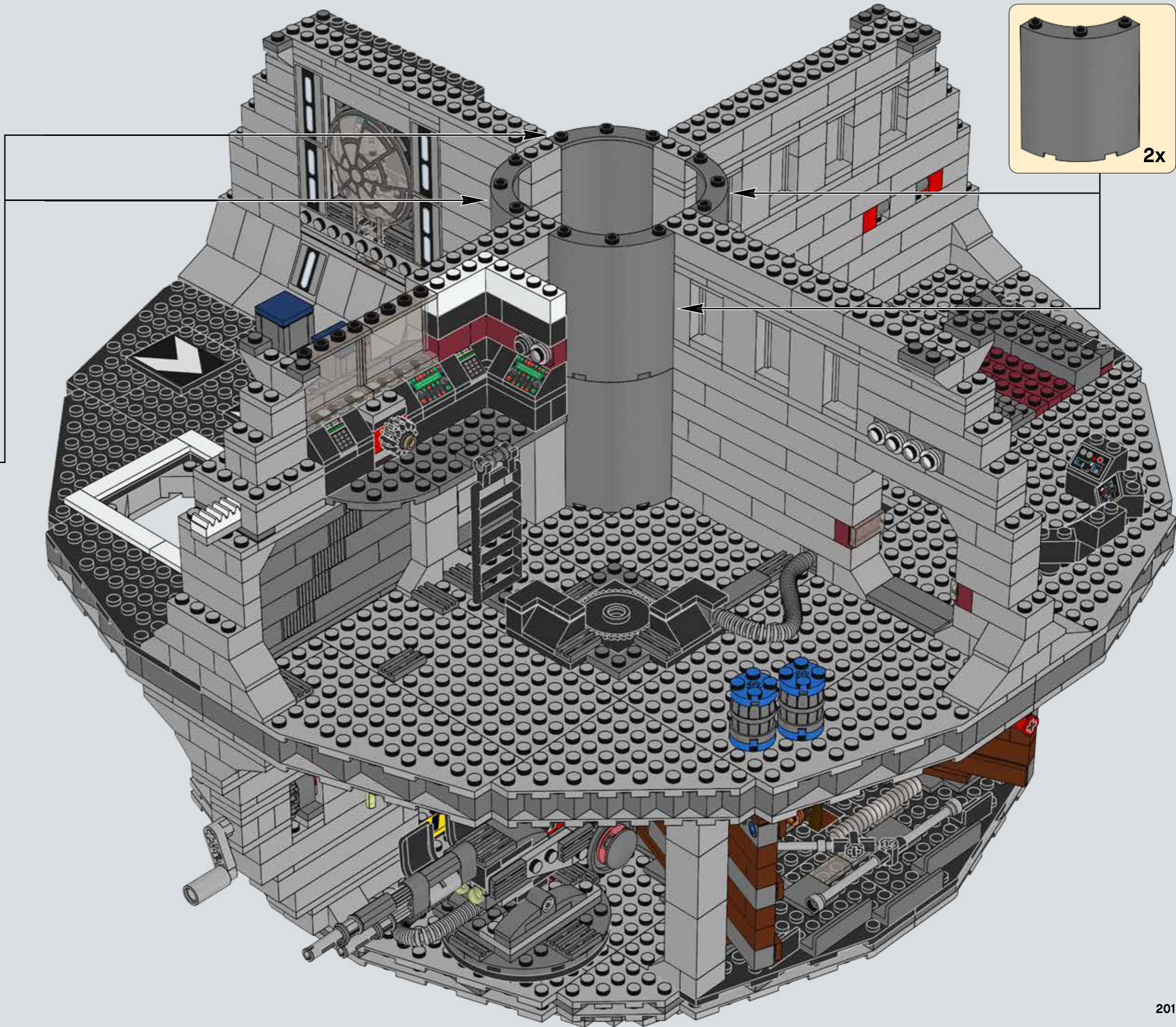
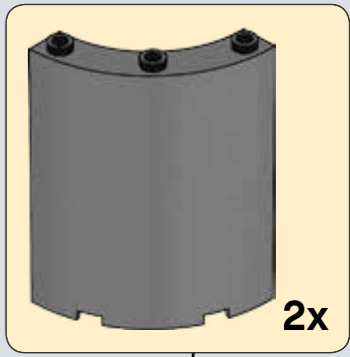
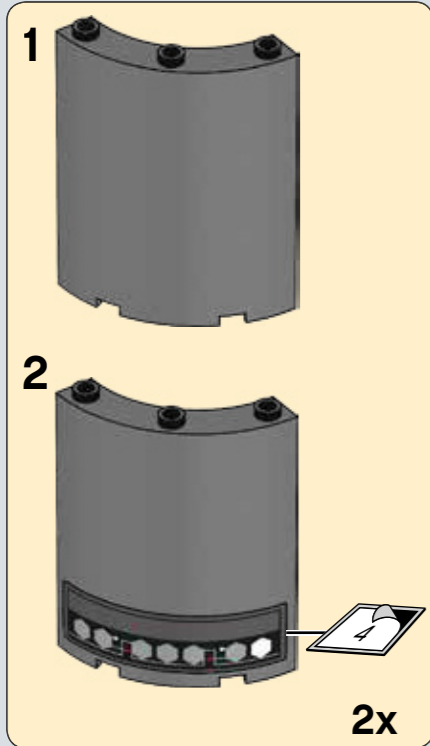

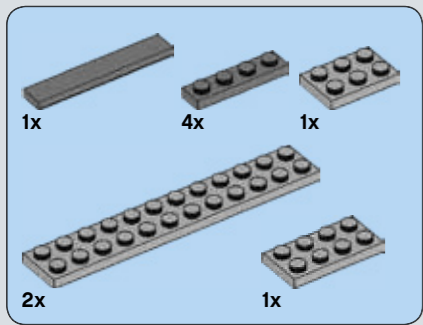

339

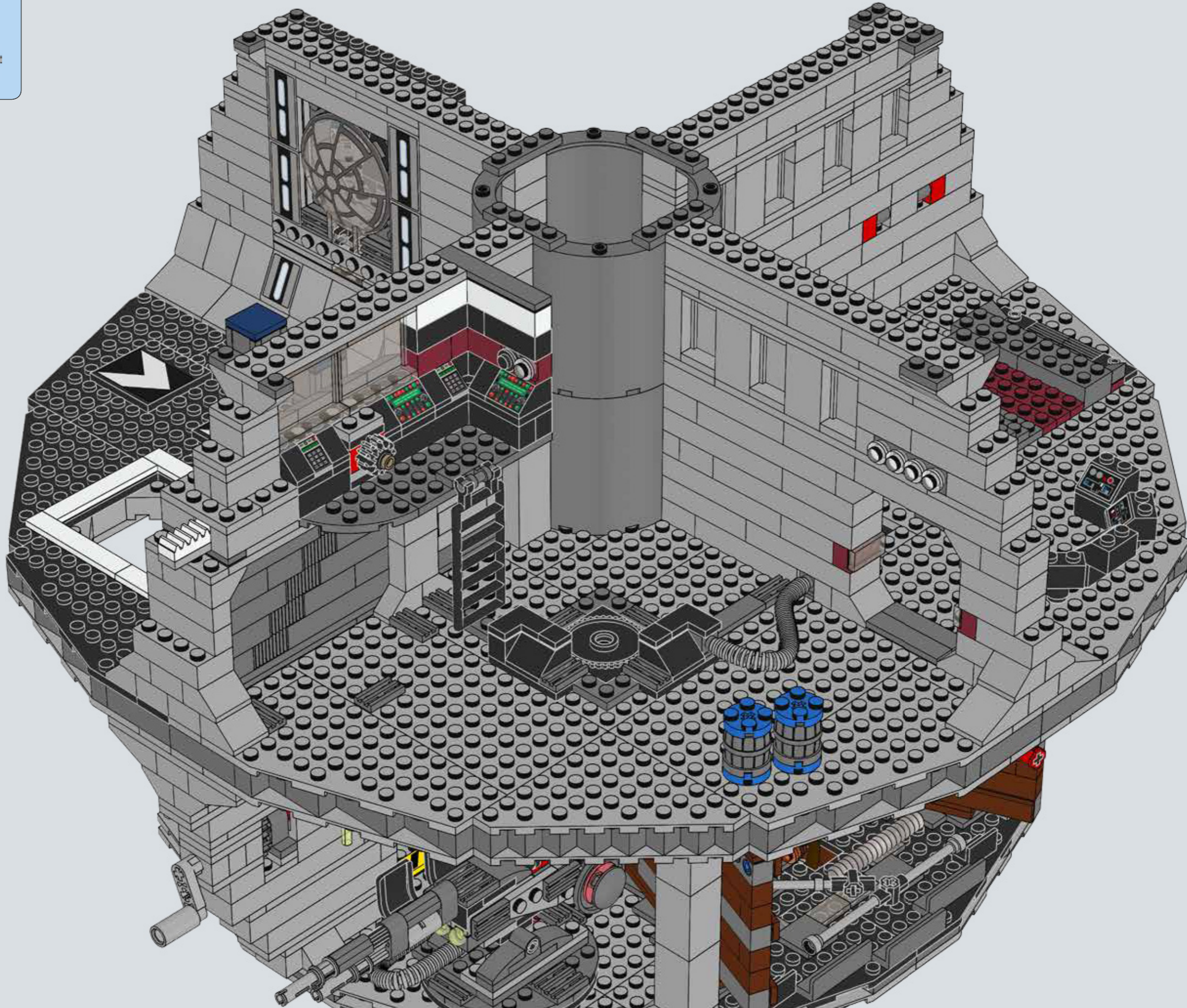

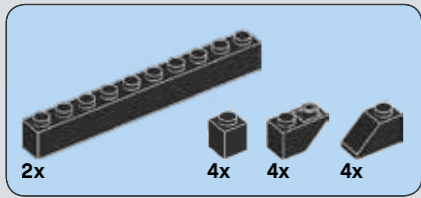

340

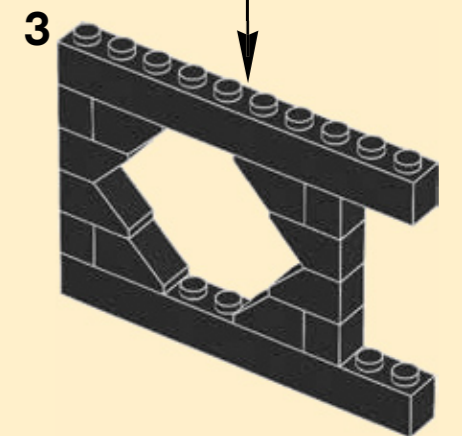
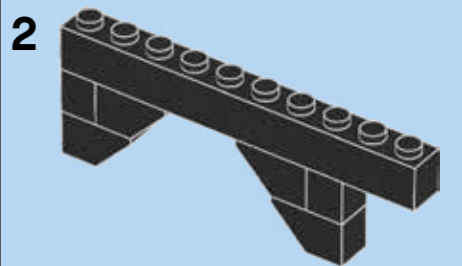
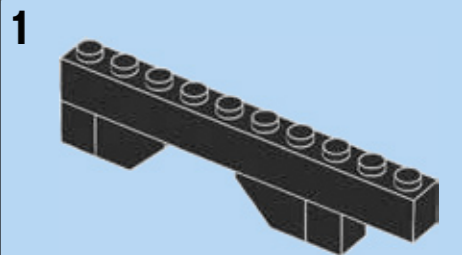
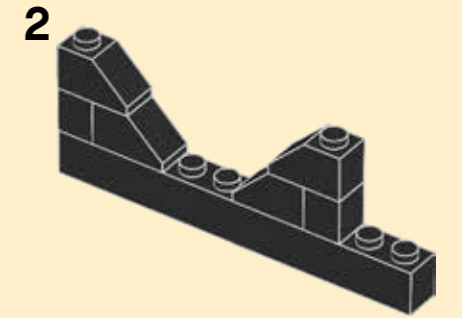
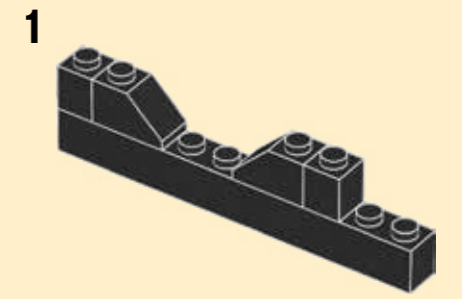
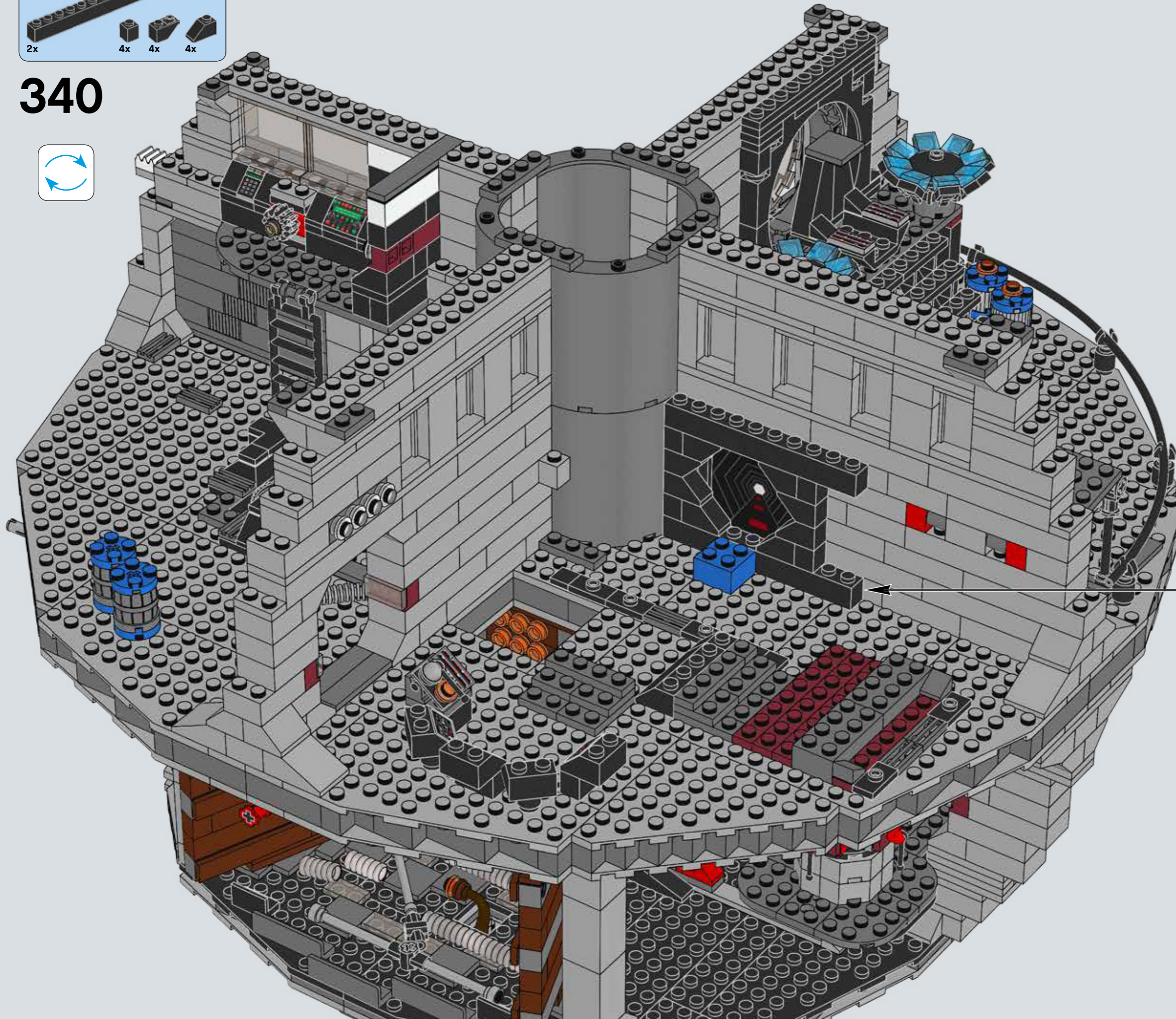

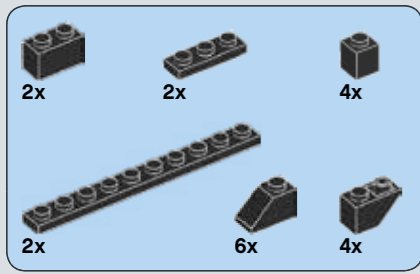

341



1

2

1

2

3

3

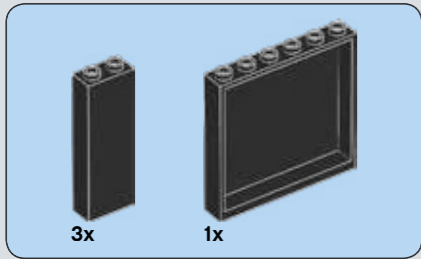

342

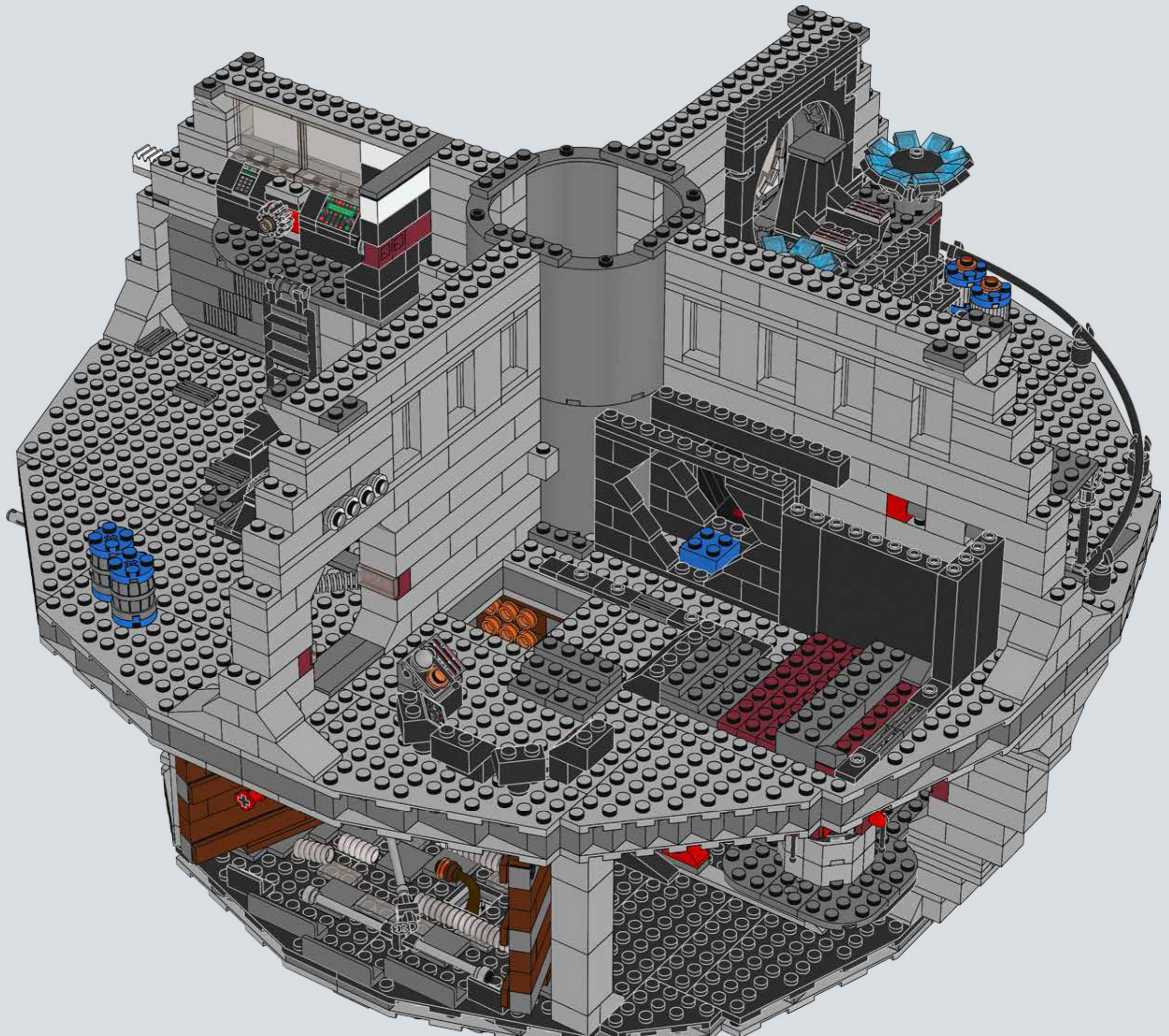

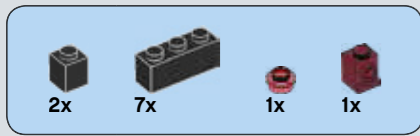

343

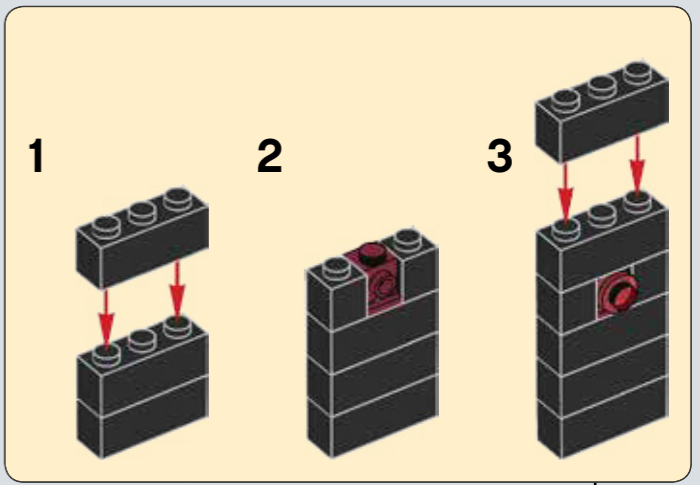
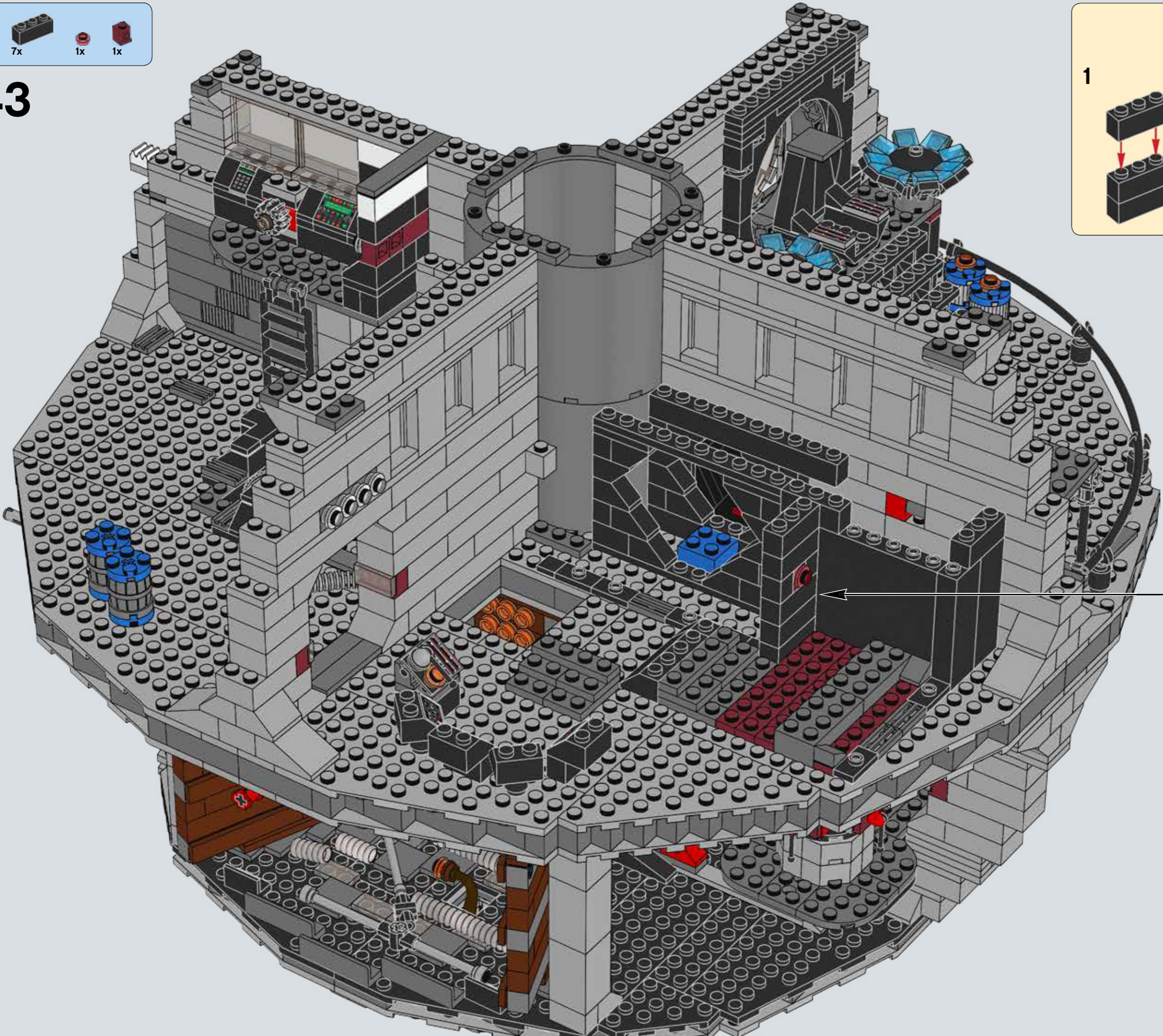

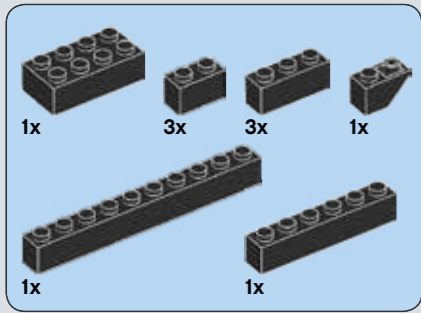

344

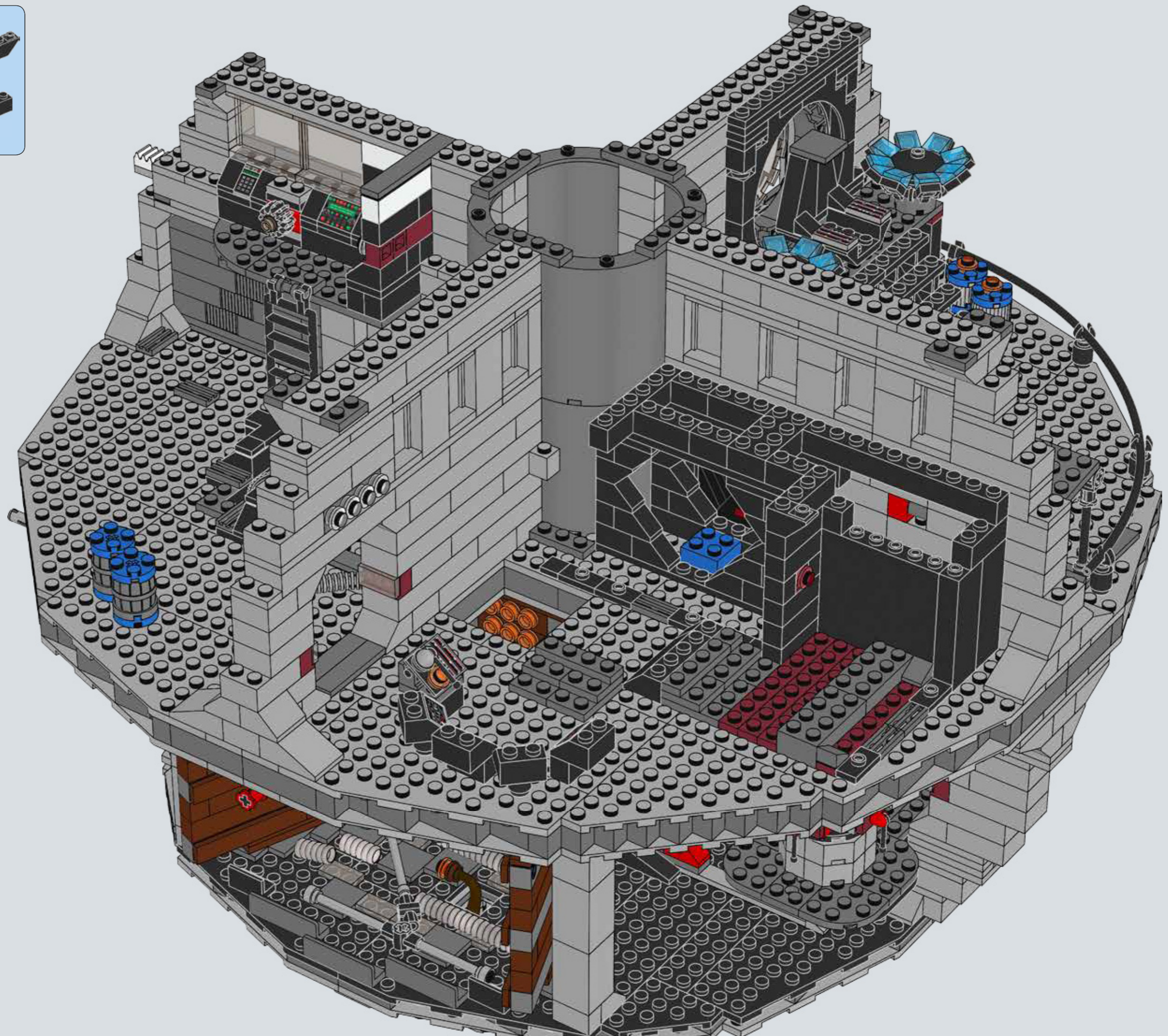

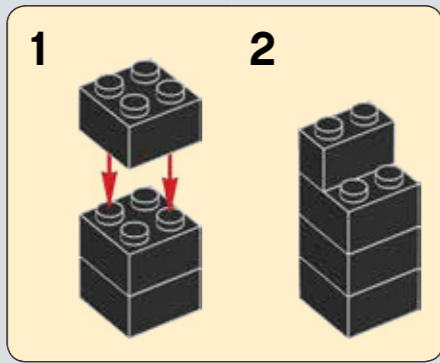
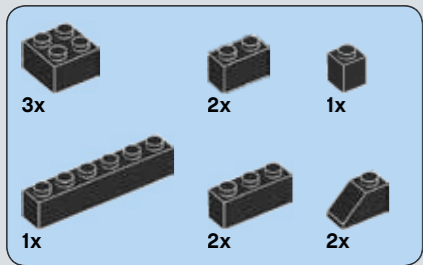



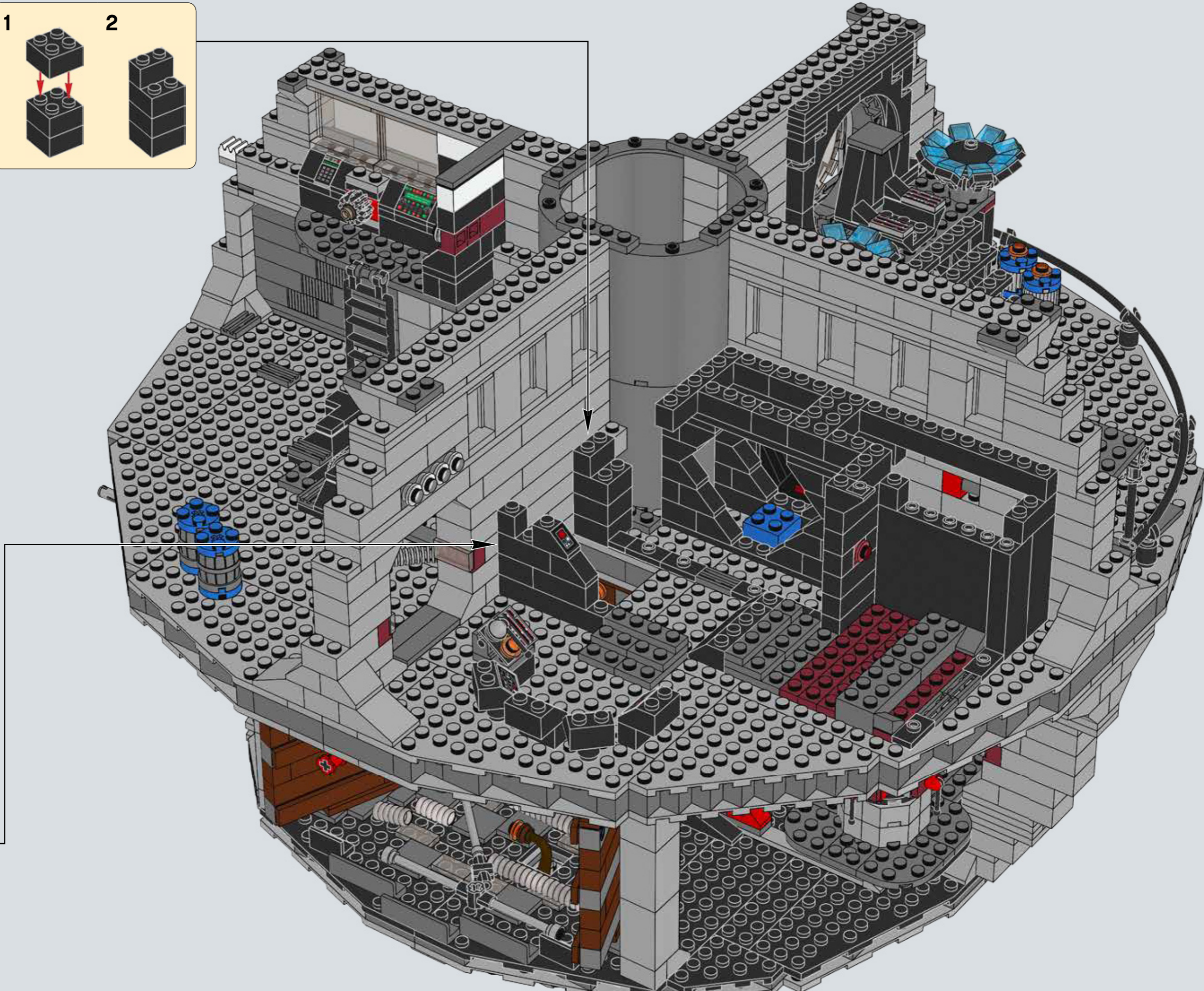
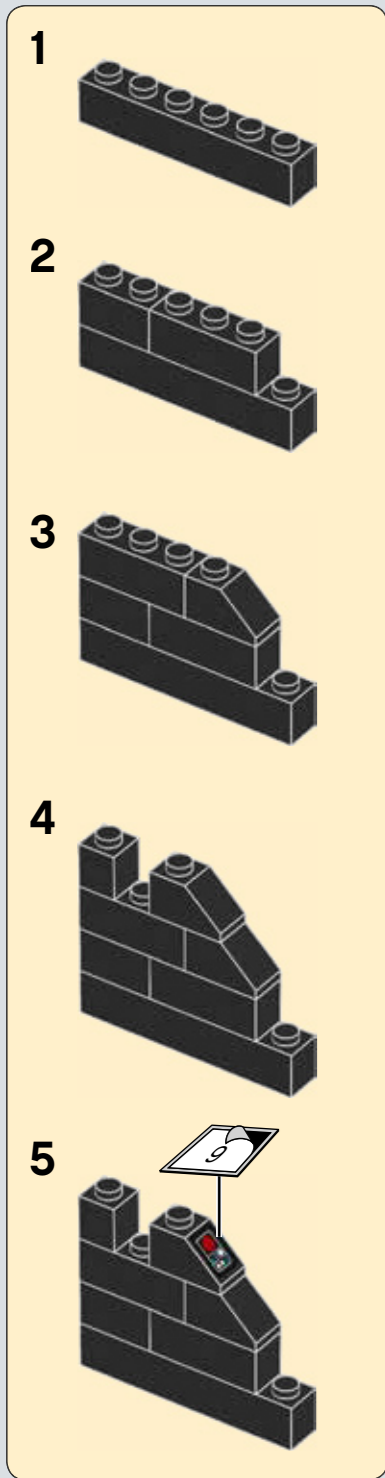

# 345

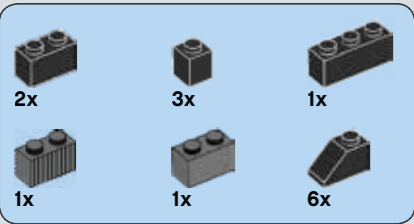



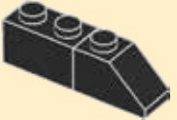
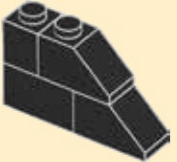

# 346

- 1 
- 2 
- 3 
- 4     
 2x

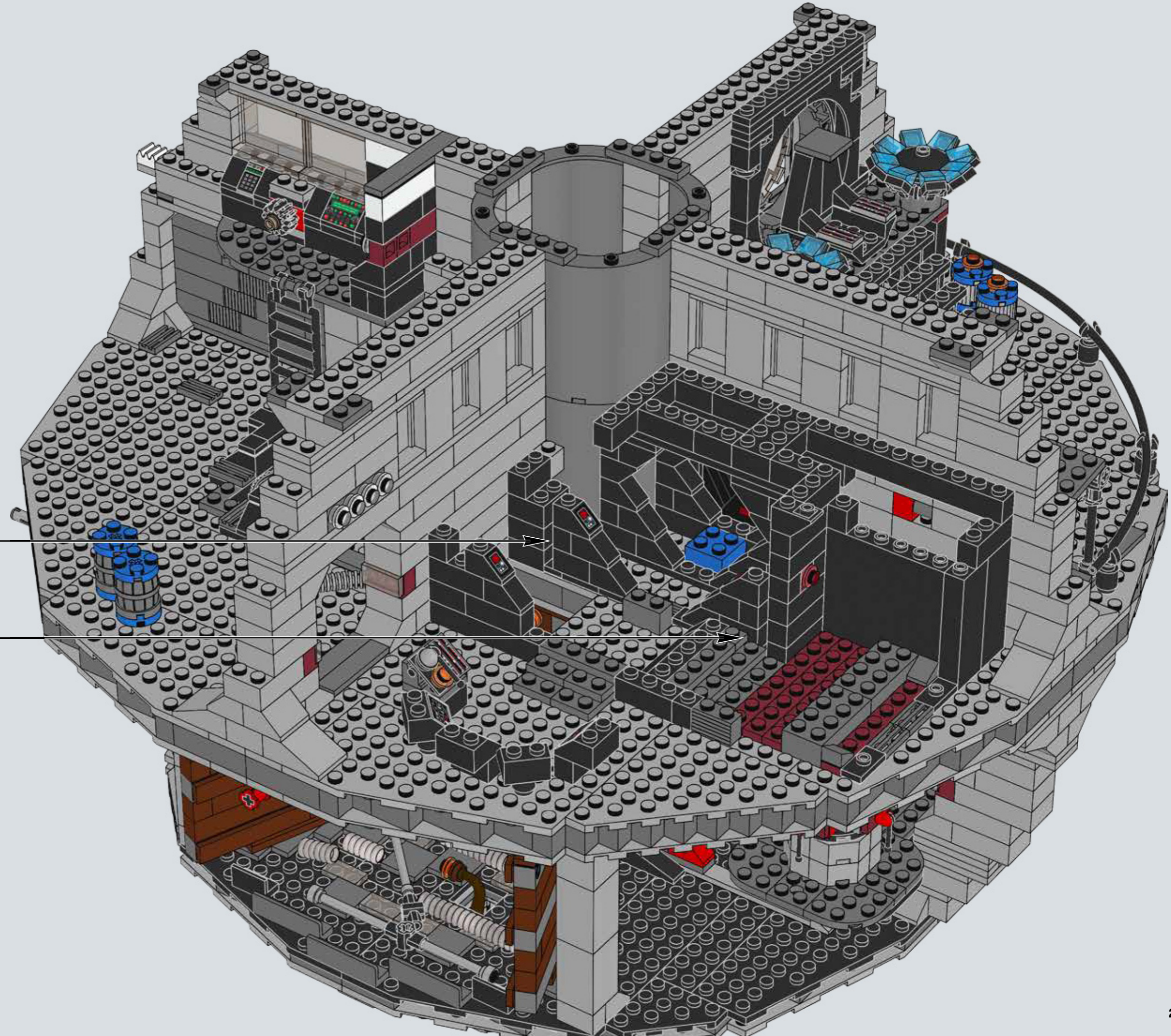

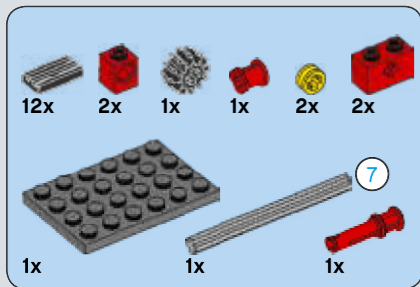

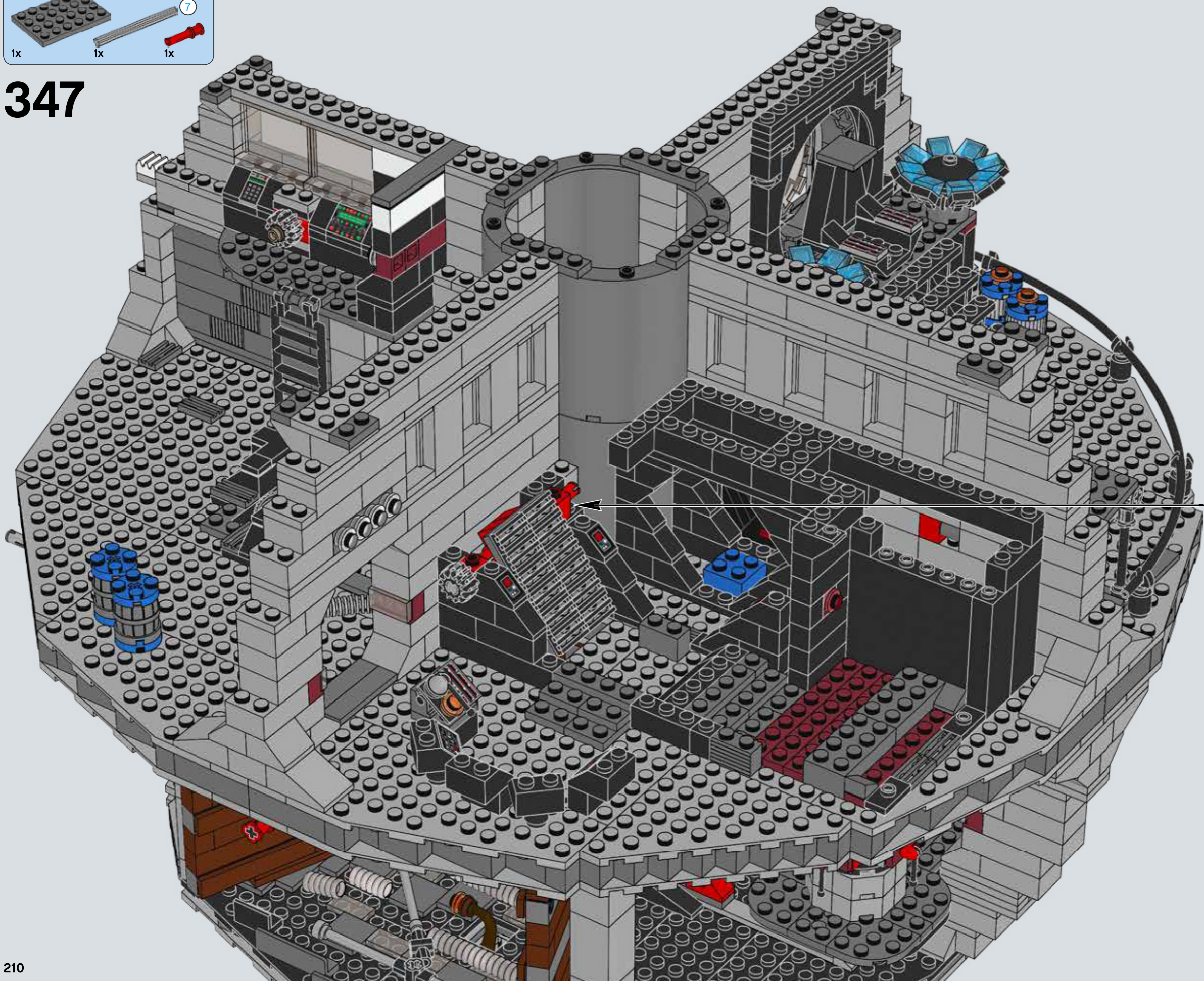

7 1:1

347

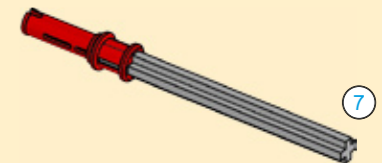
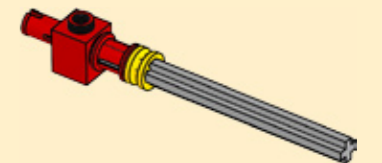
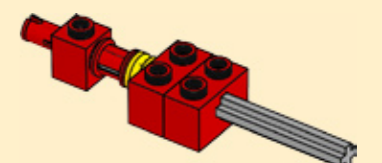
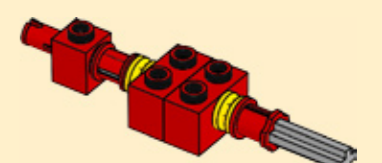
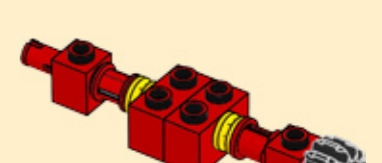

- 1 
- 2 
- 3 
- 4 
- 5 
- 6 
- 7 

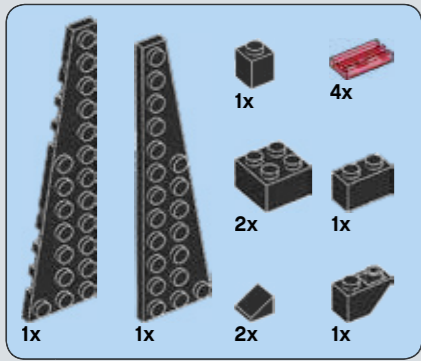

348

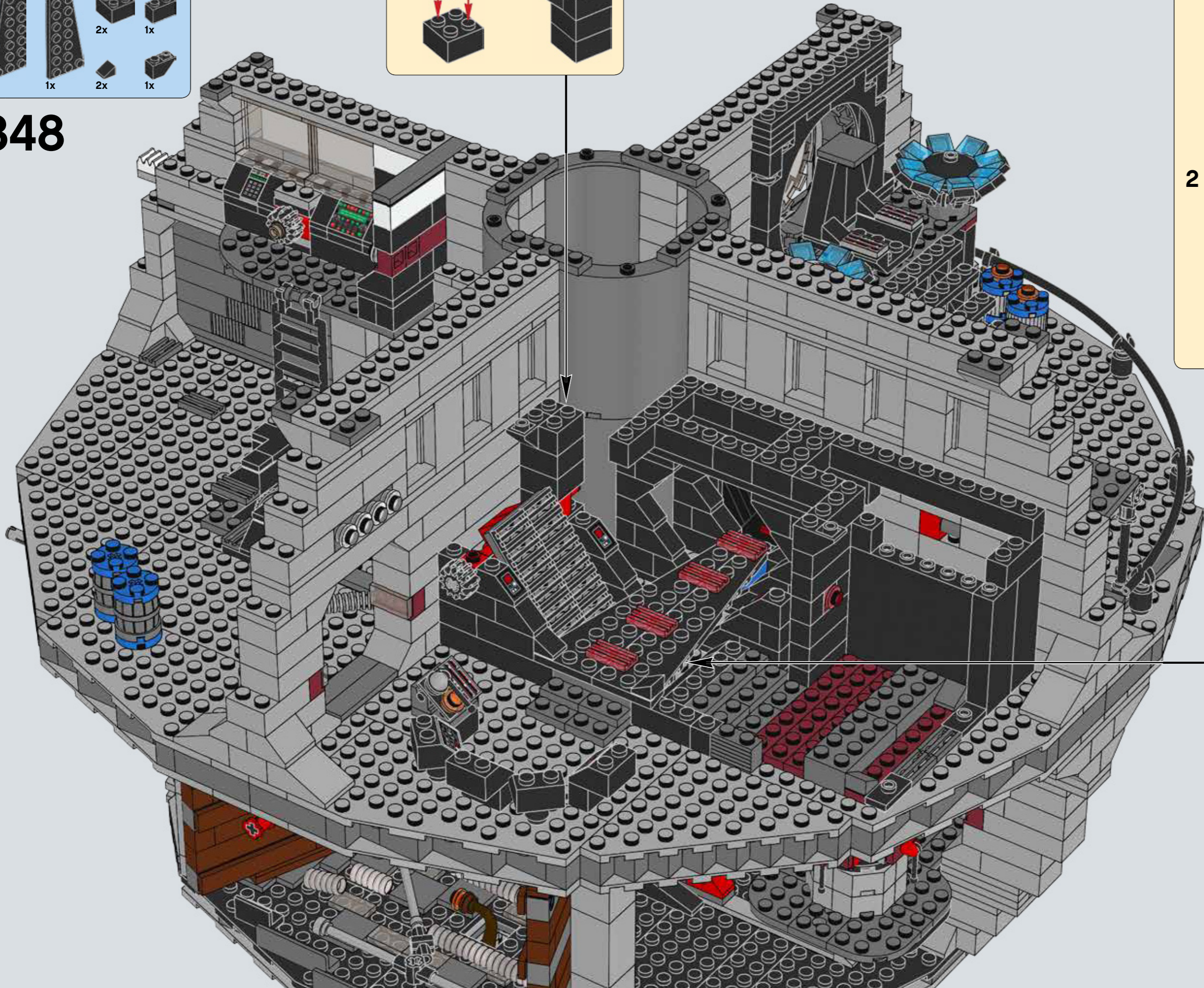
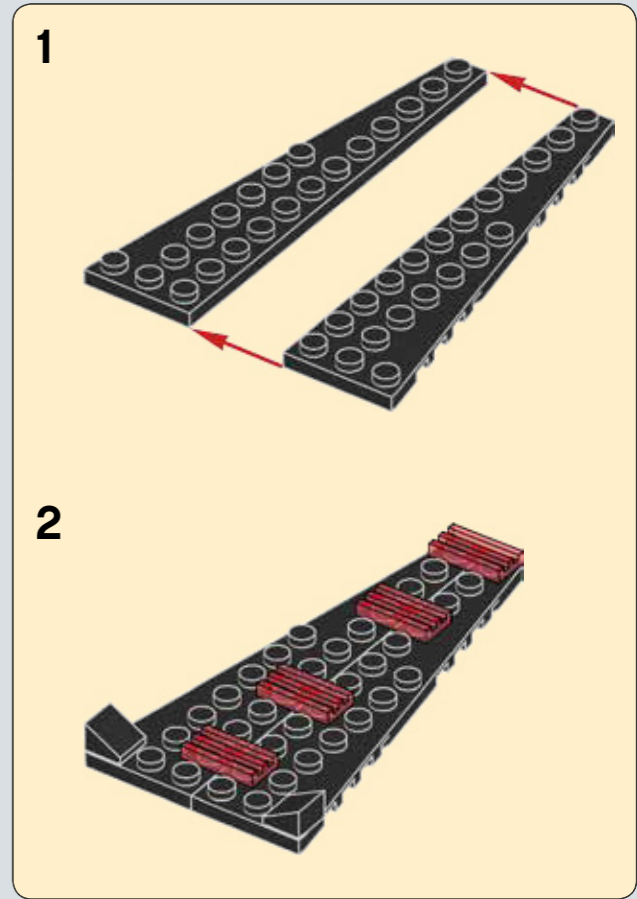
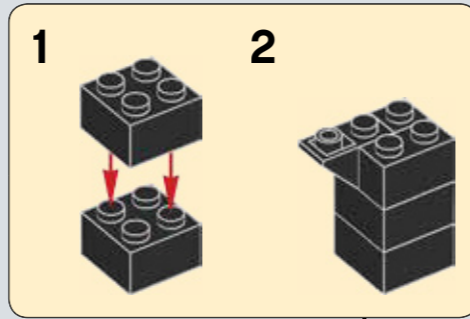

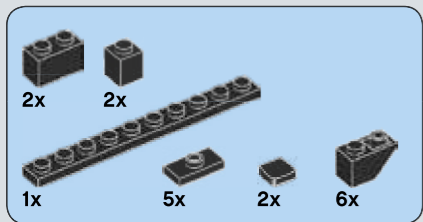

349

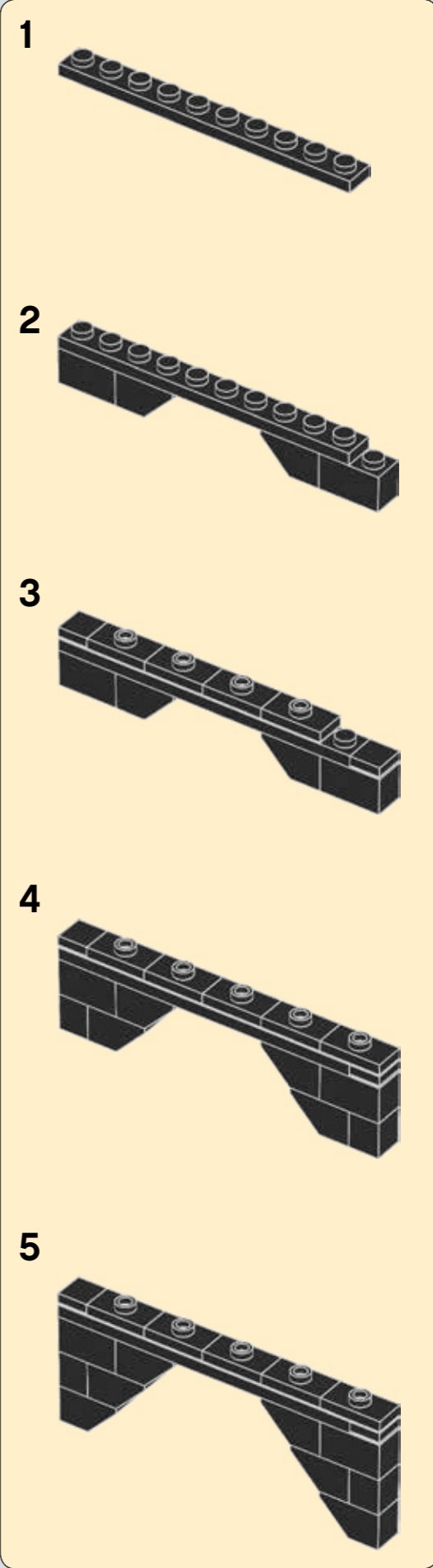
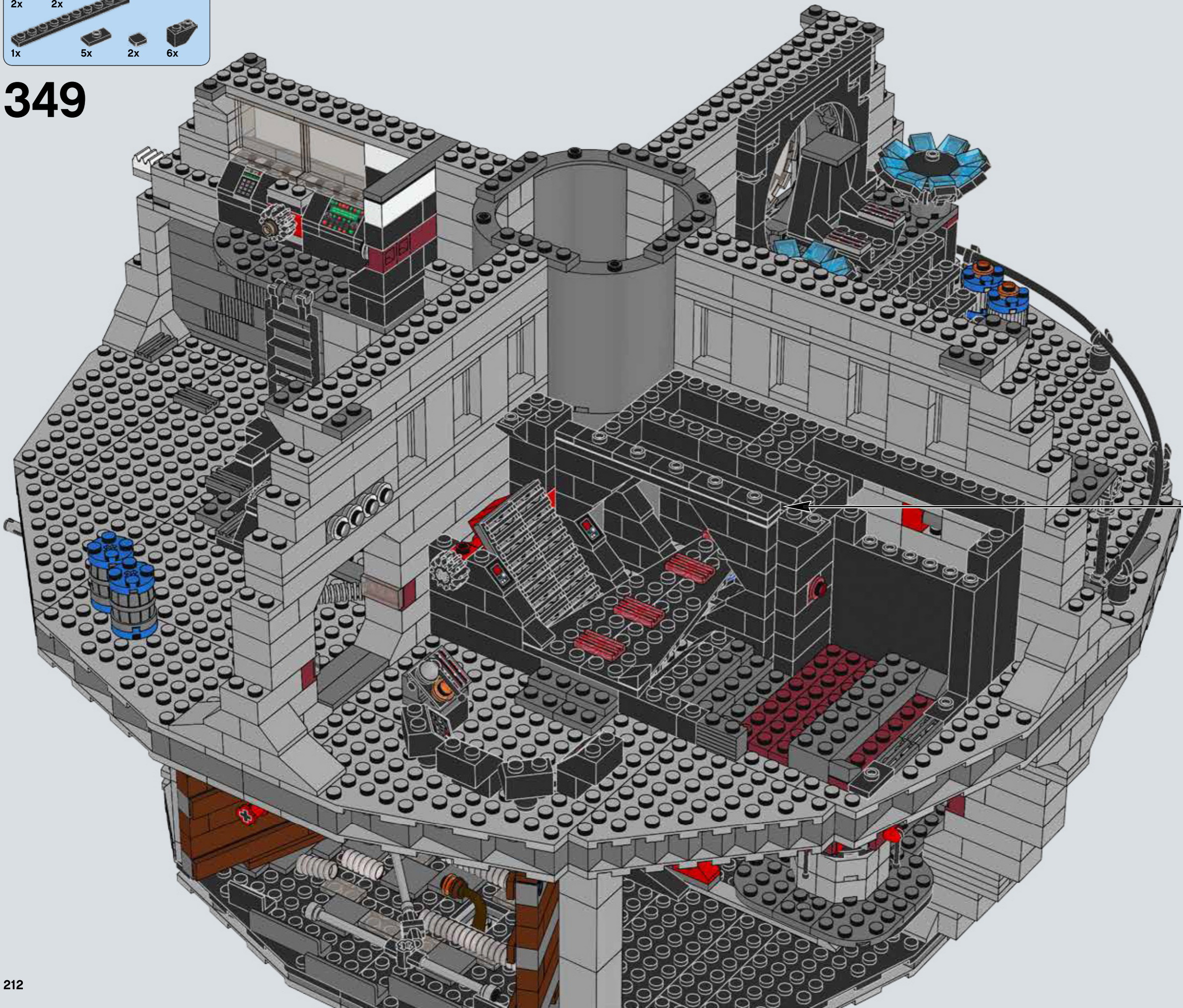

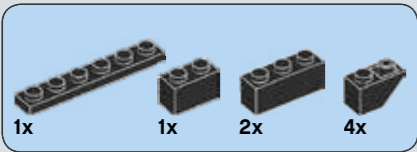

350

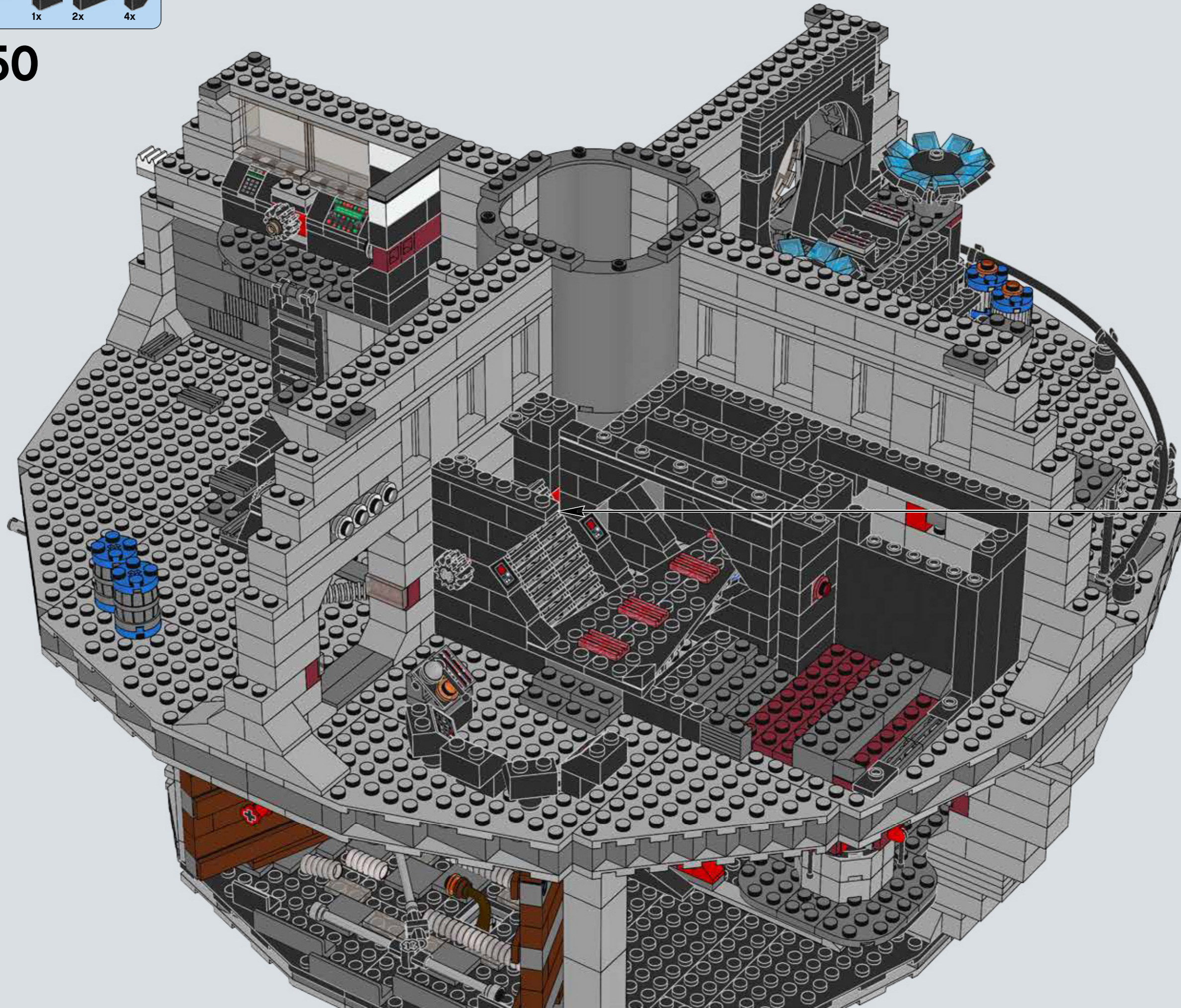

- 1
- 2
- 3
- 4

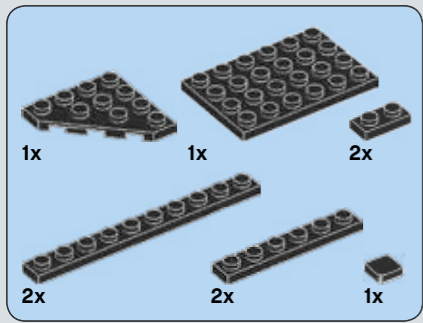

351

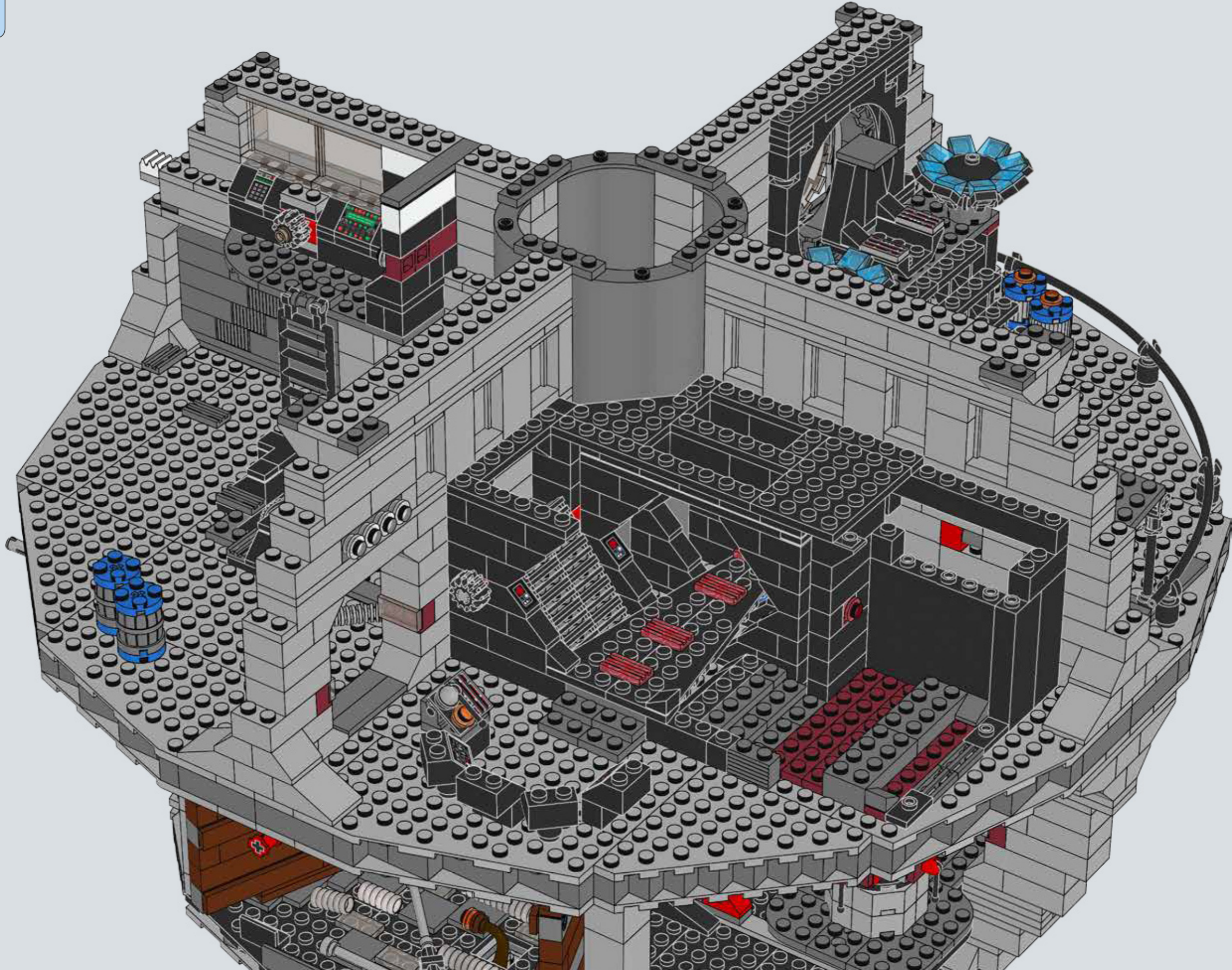

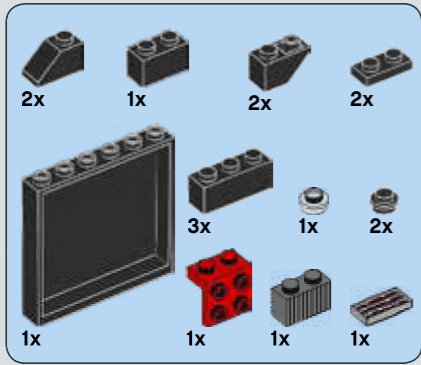

**352**

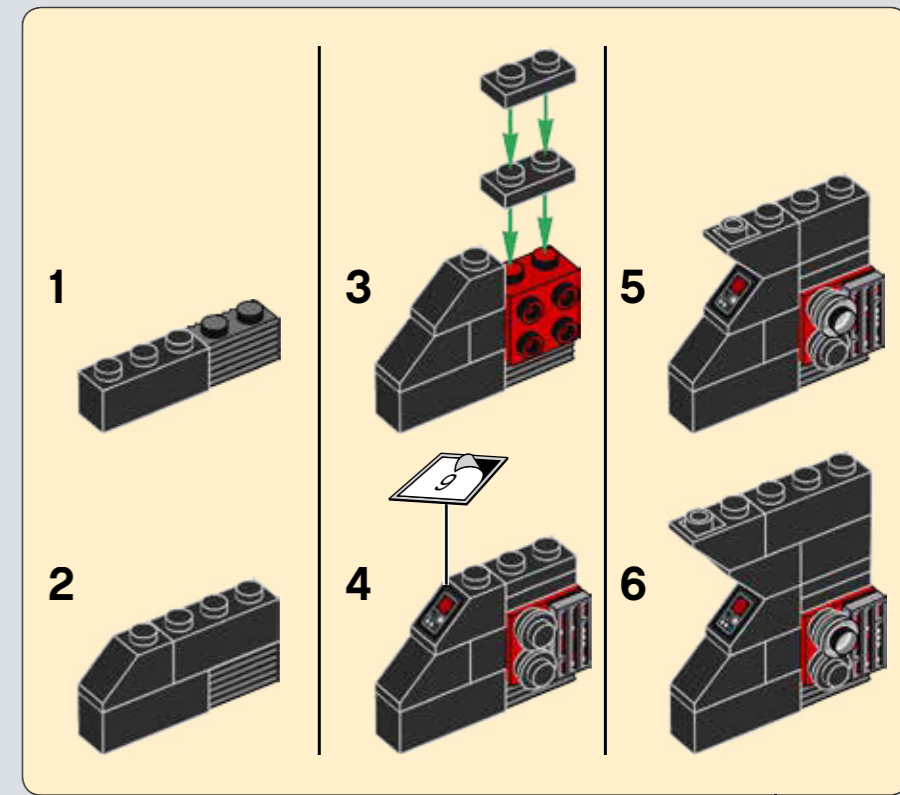
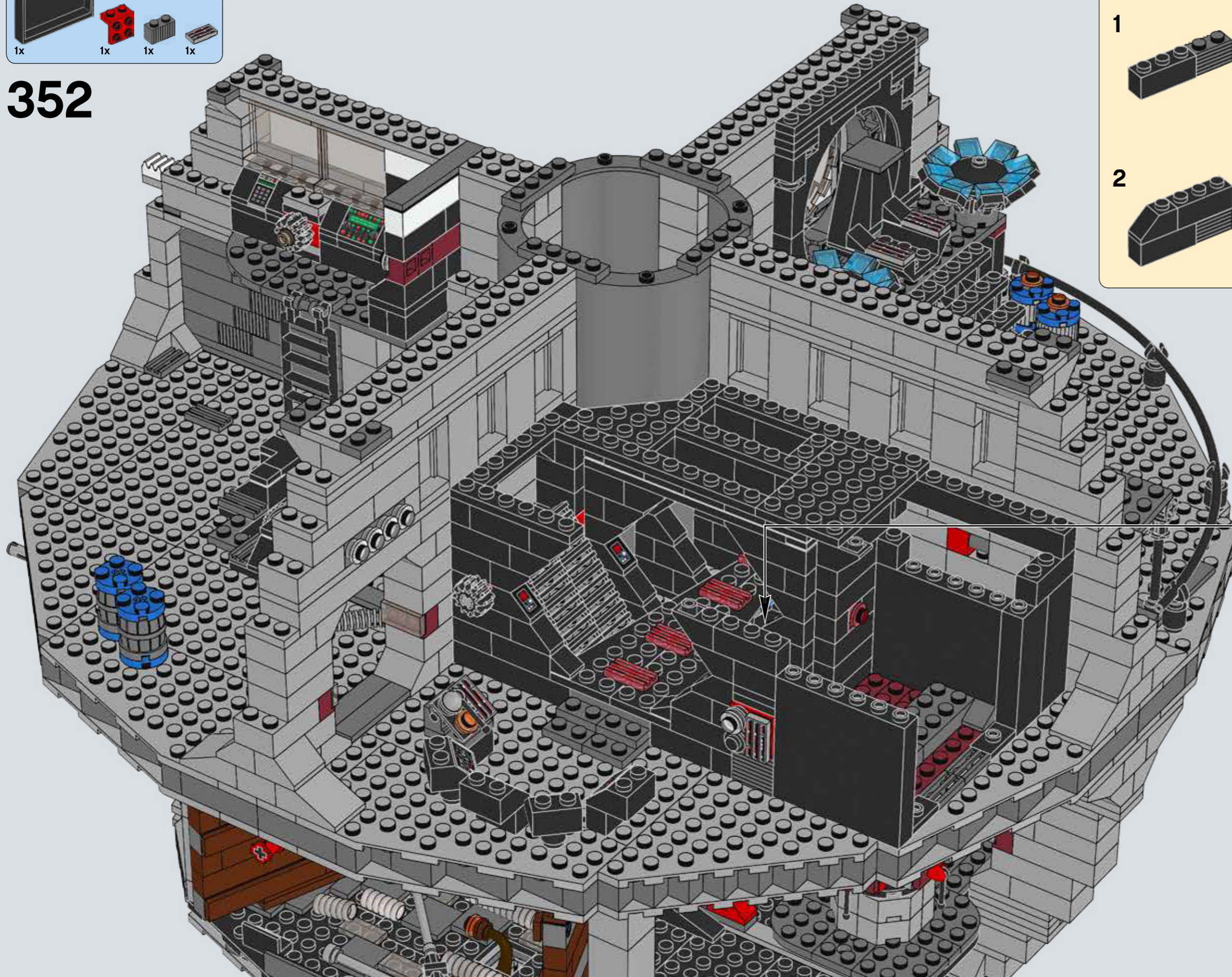

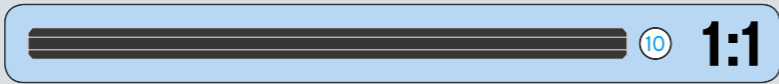
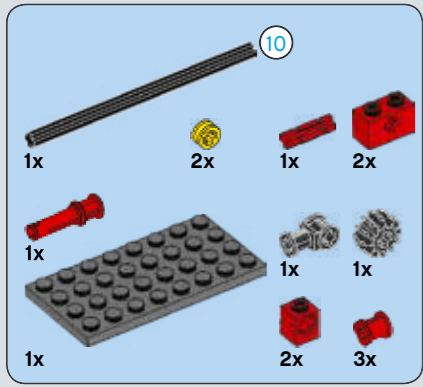

# 353

- 1
- 2
- 3

- 4
- 5
- 6
- 7



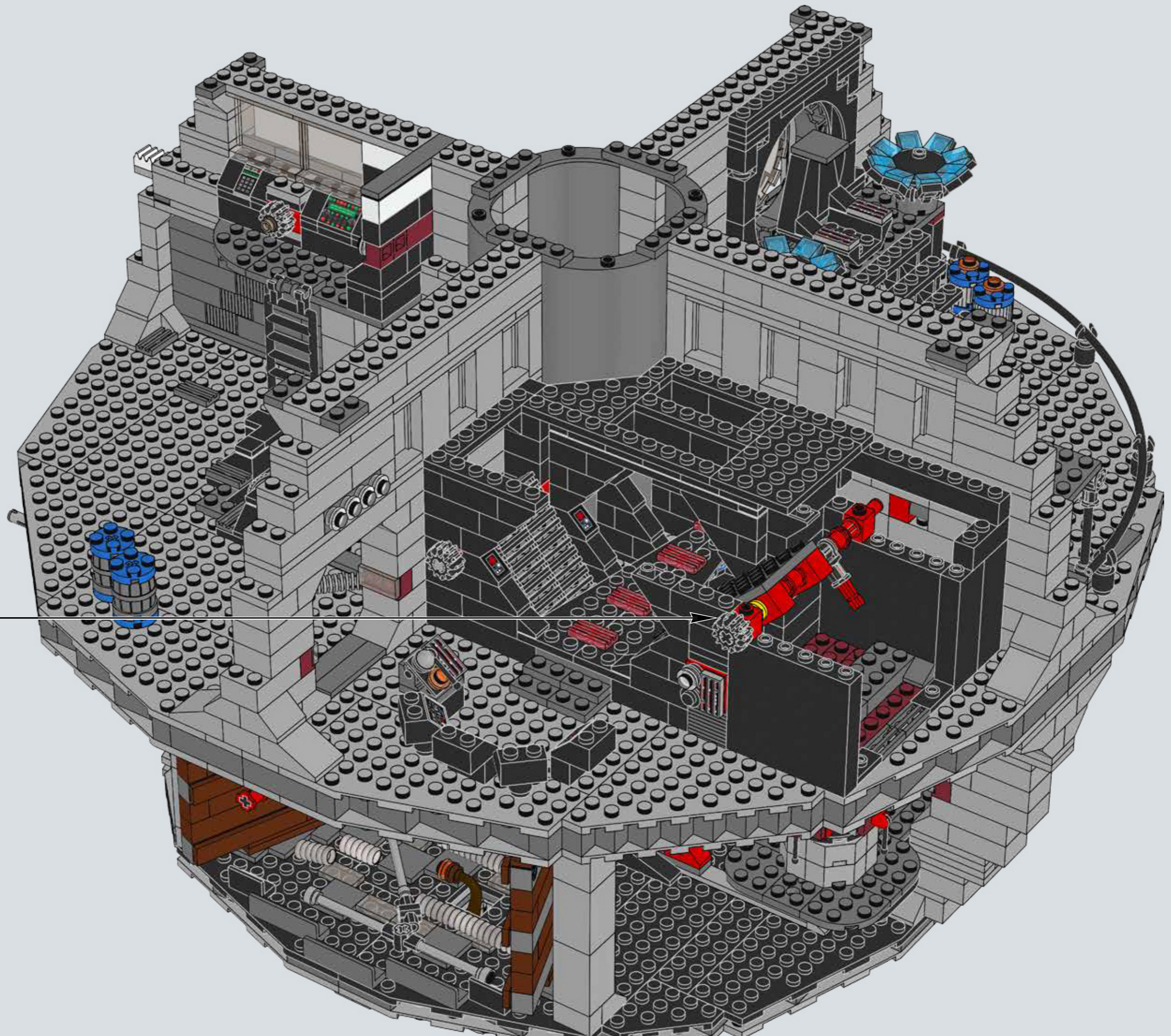

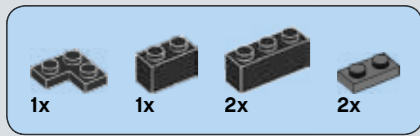

354

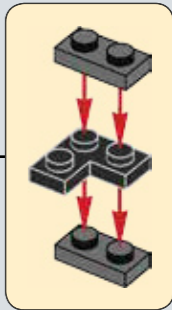
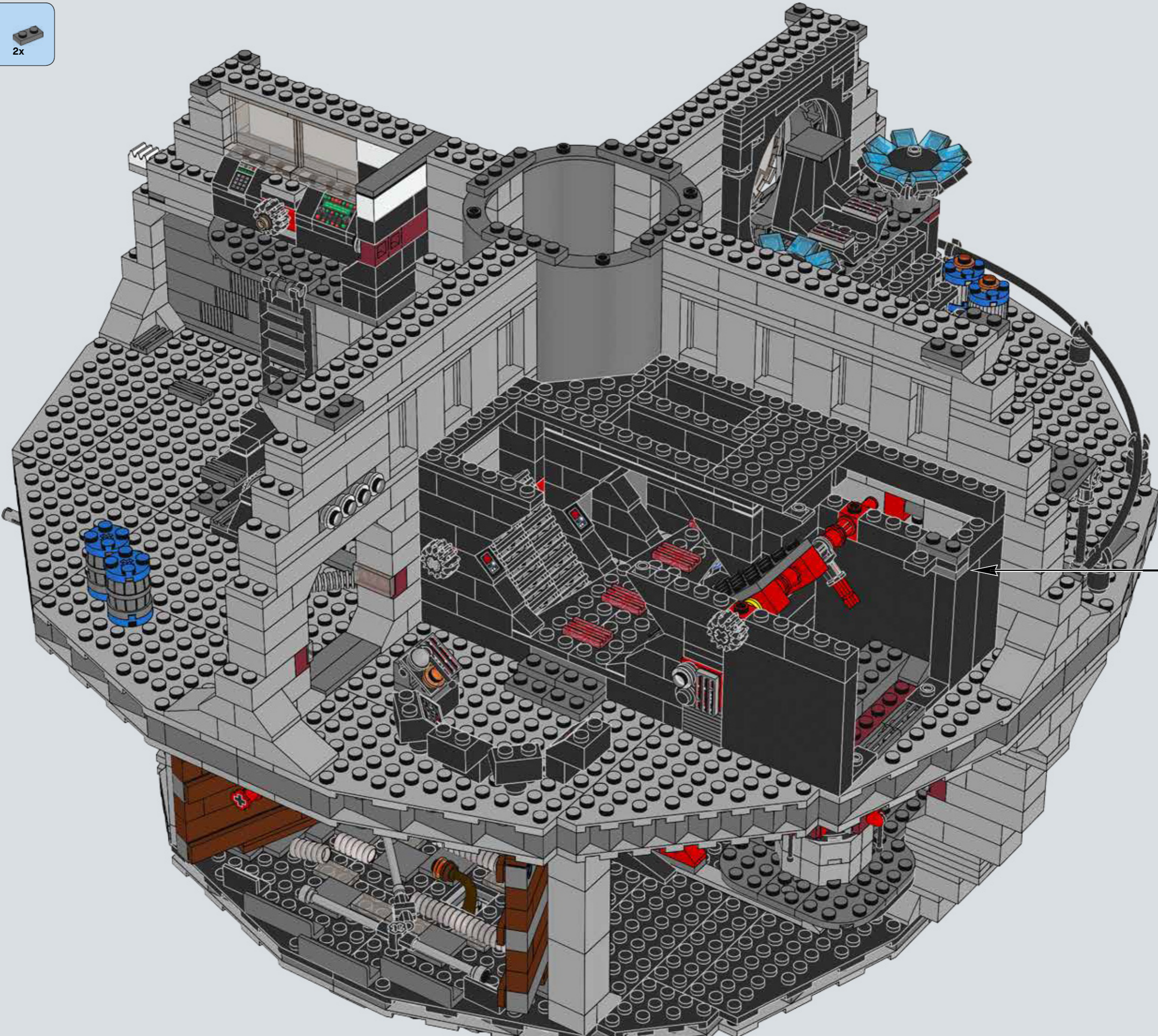

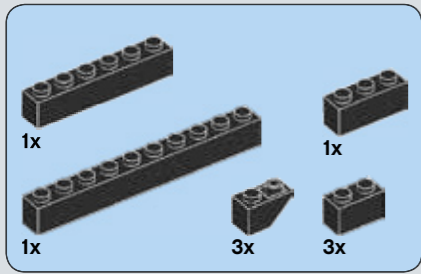

355

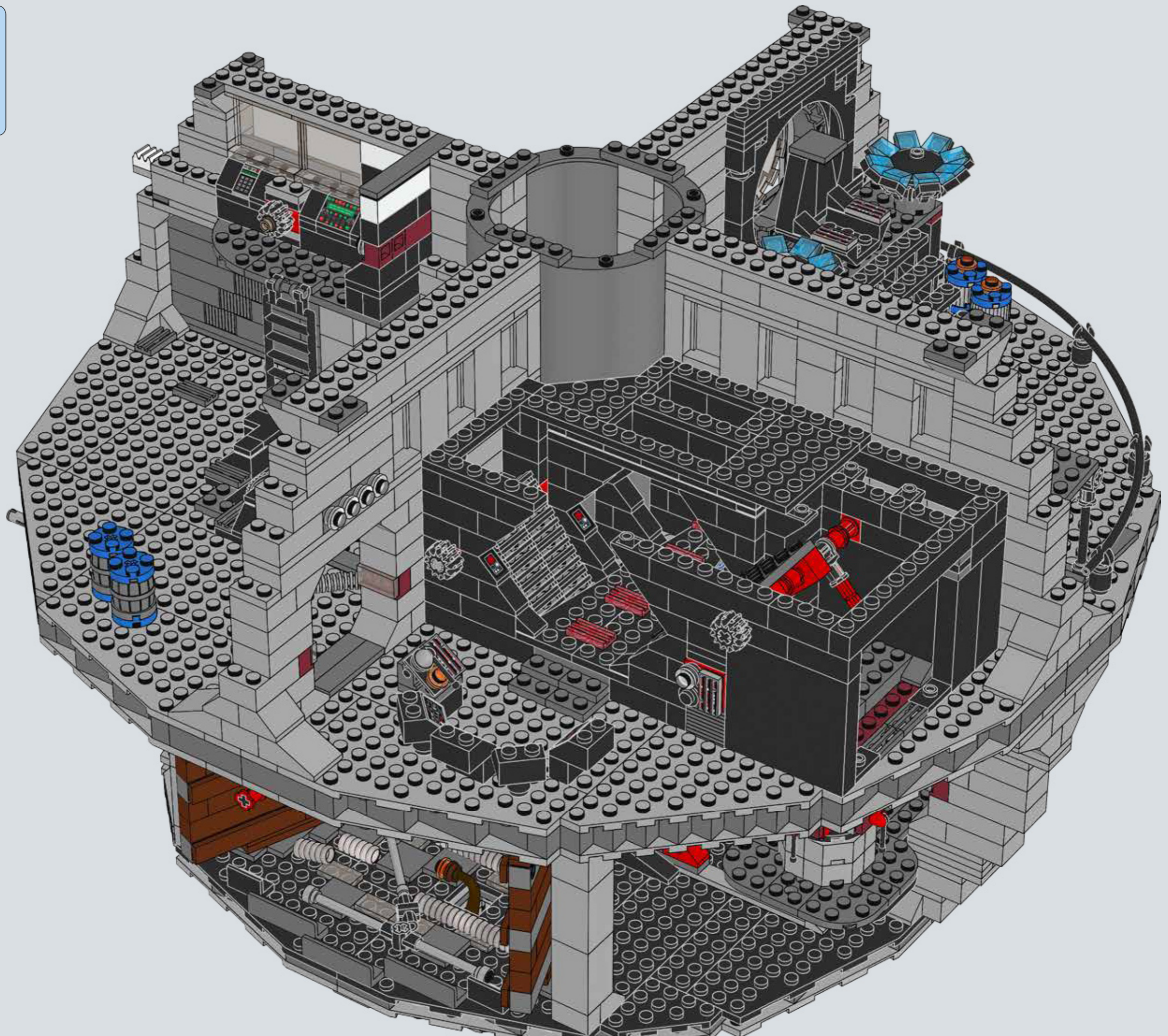

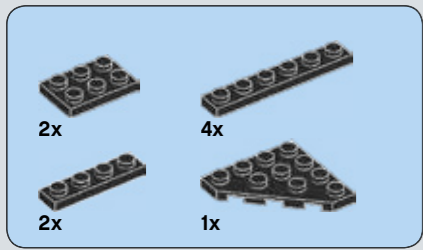

356

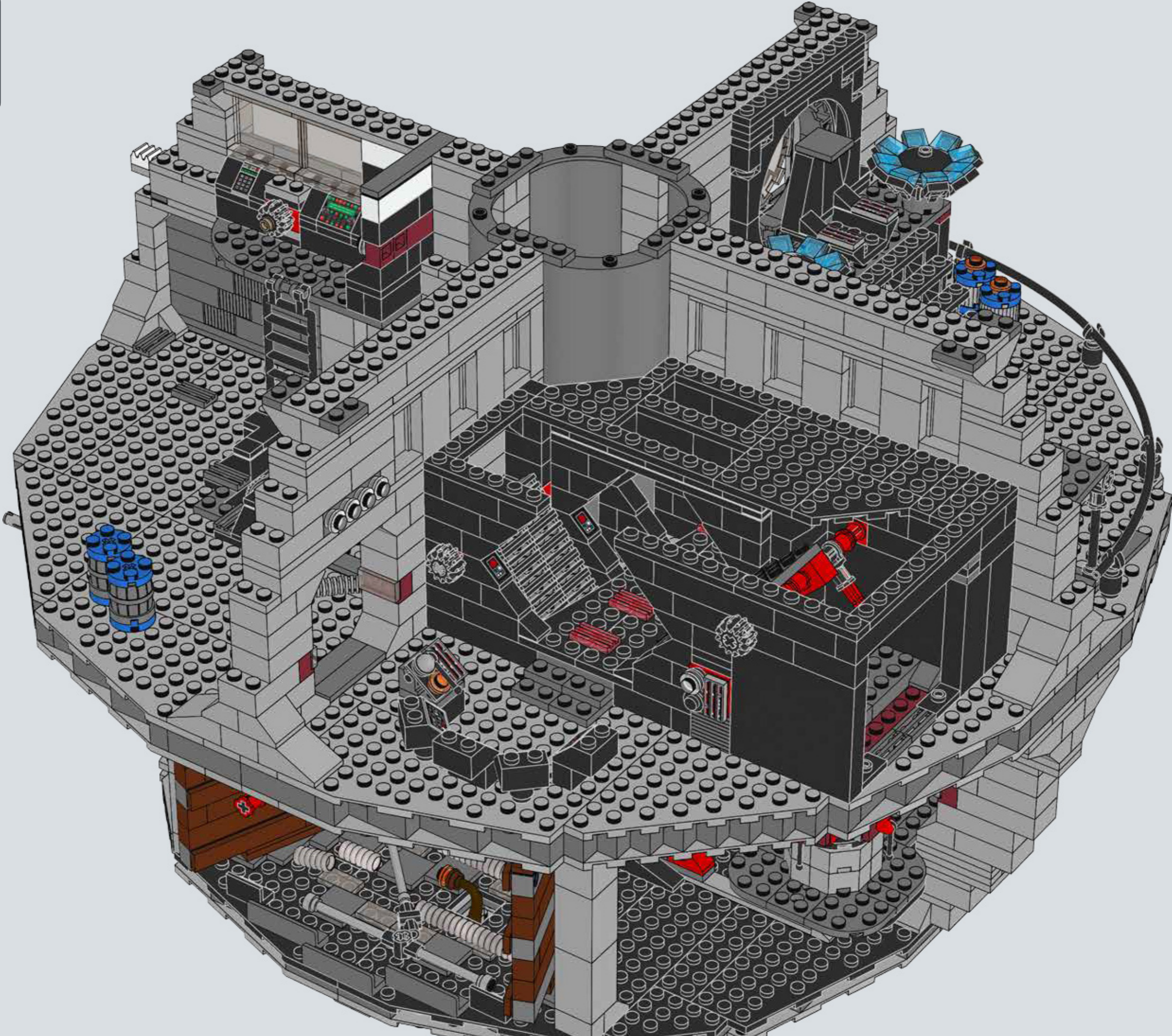

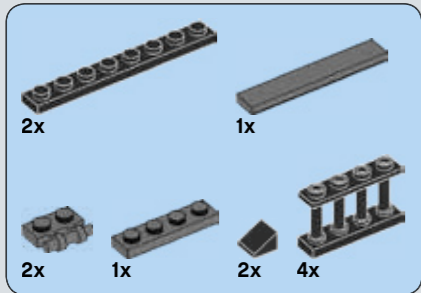

357

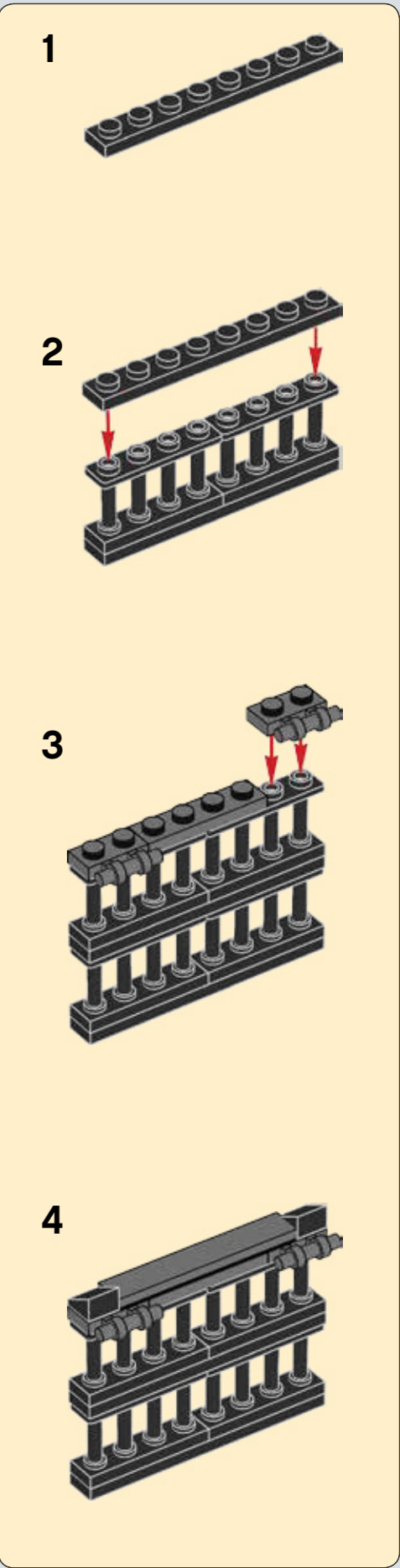
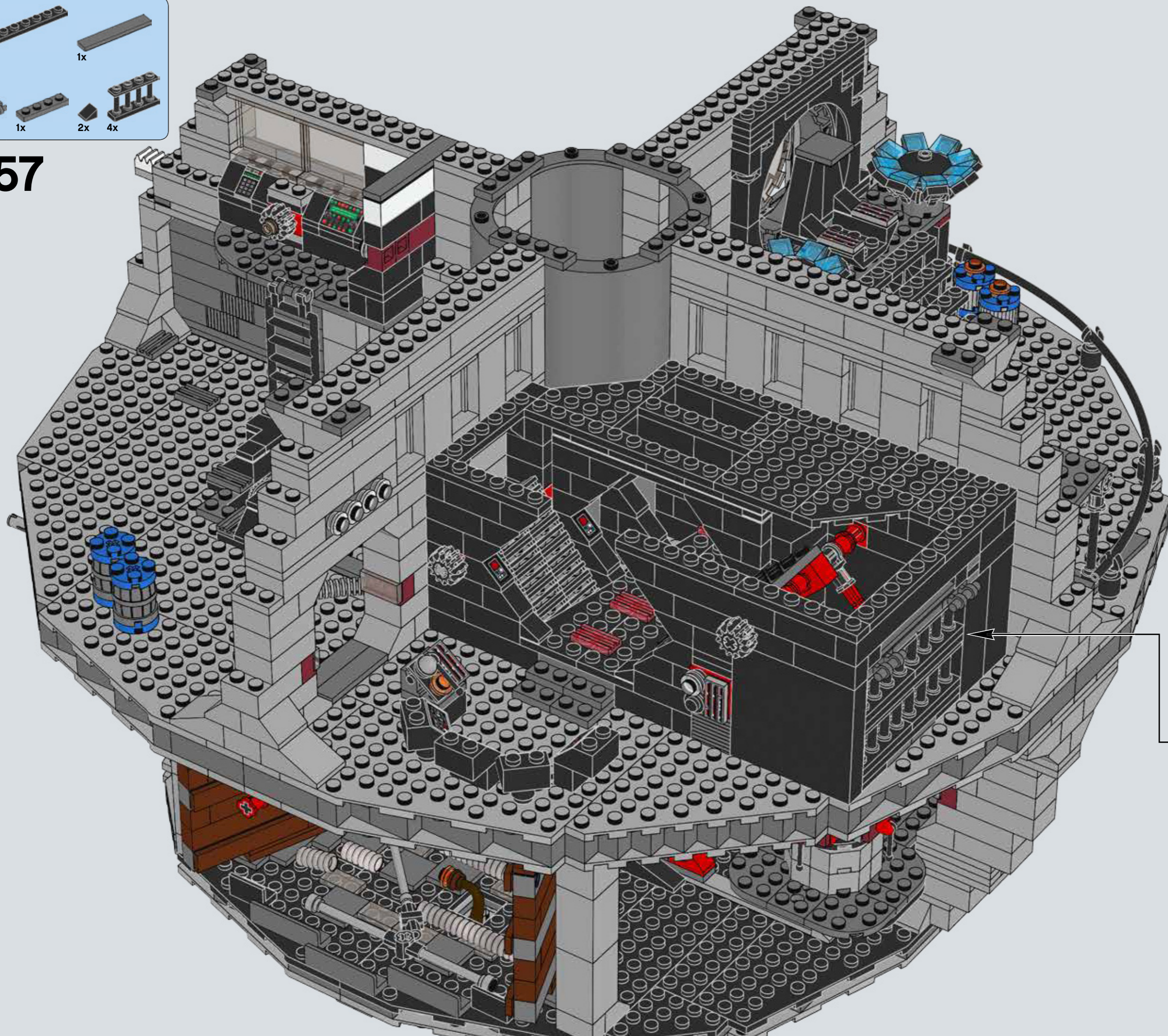

- 1x
- 1x
- 2x
- 2x
- 1x
- 1x
- 1x
- 1x

358

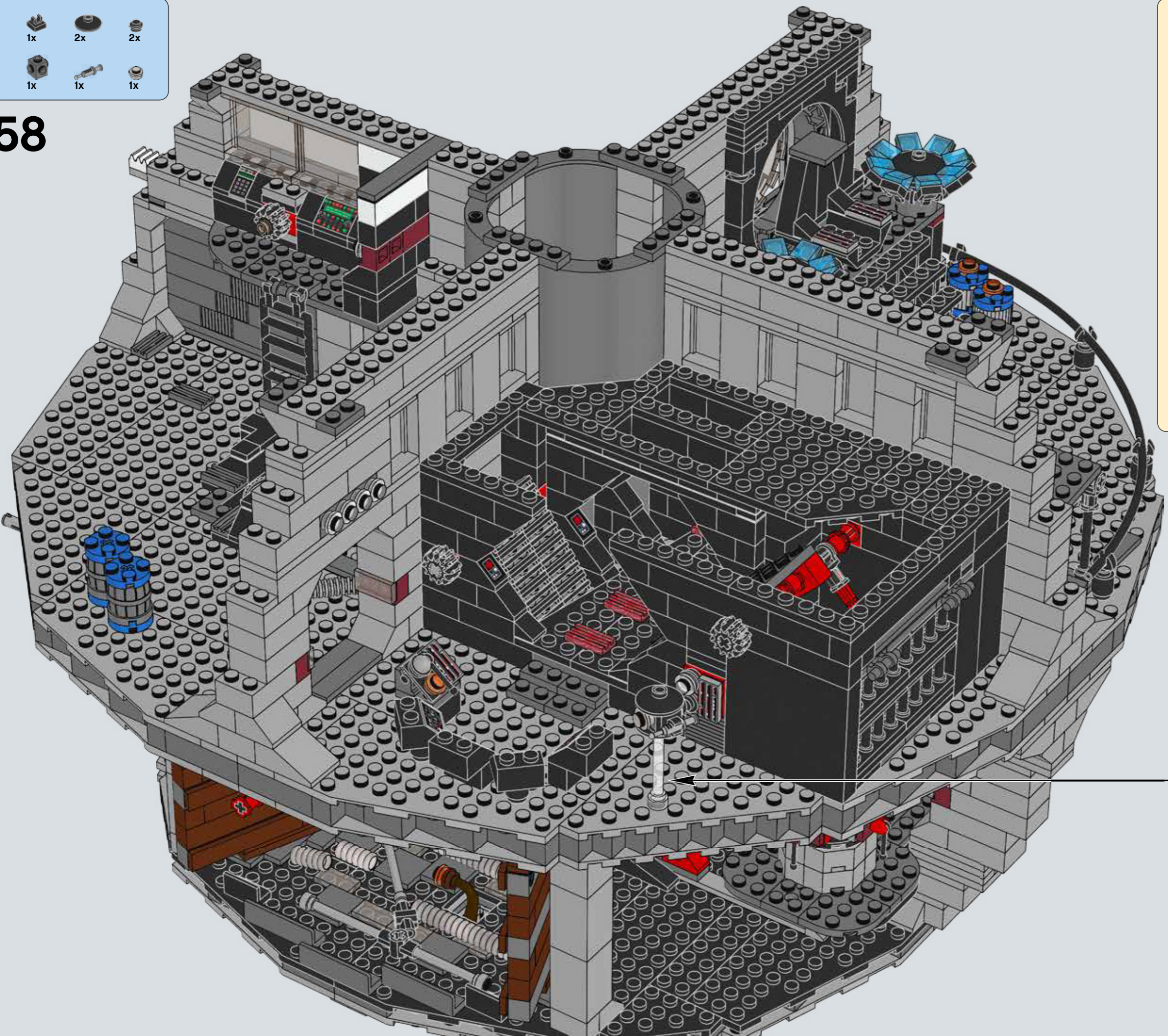

1		4	
2		5	
3			

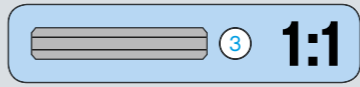
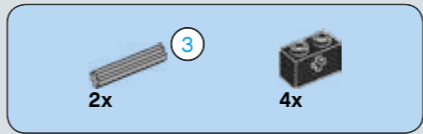
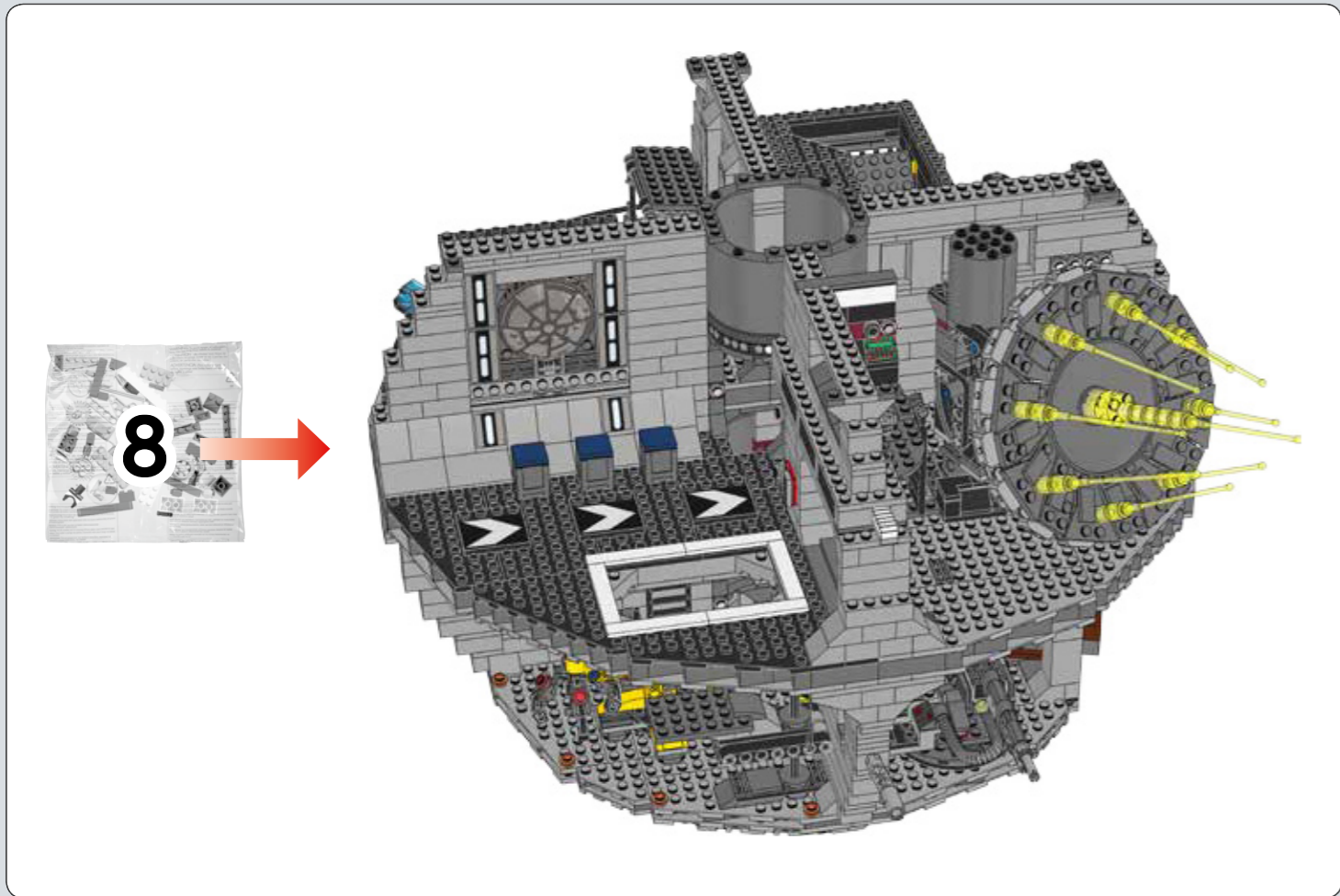

# 360

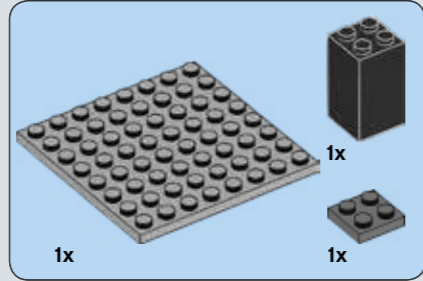
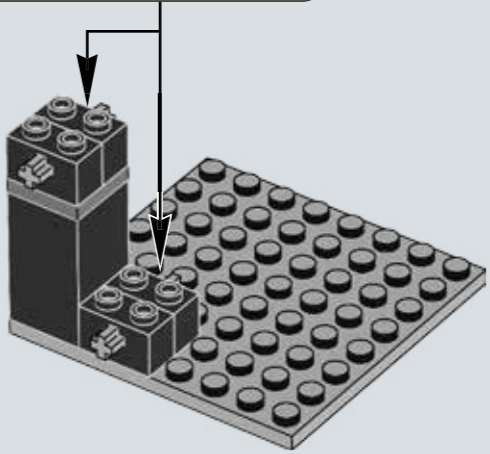
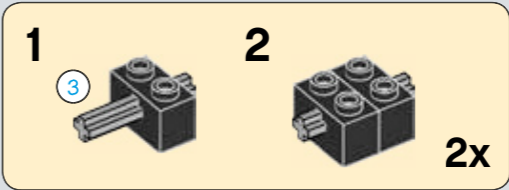

# 359

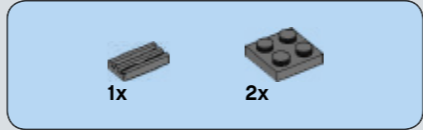
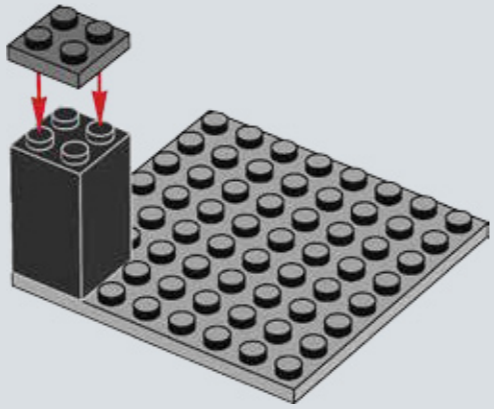

# 361

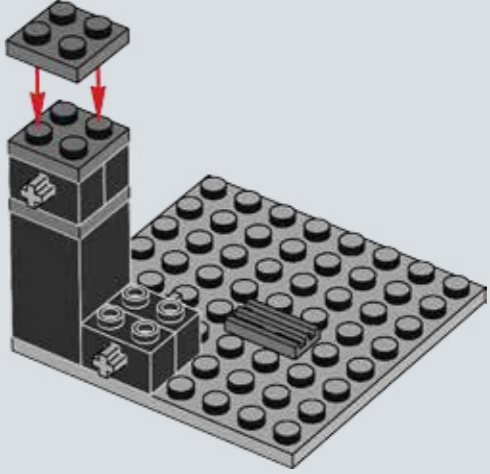

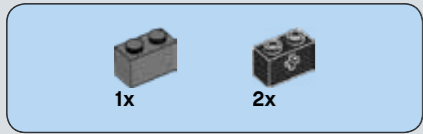

# 362

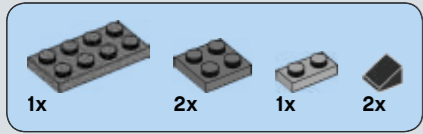
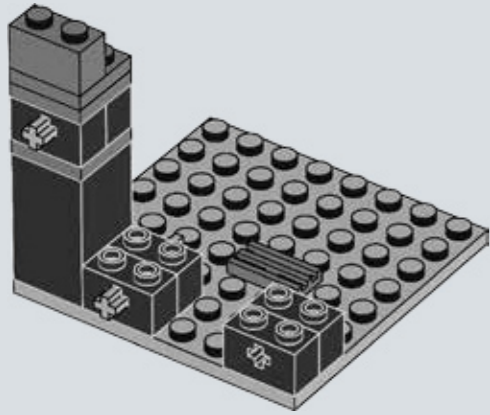

# 363

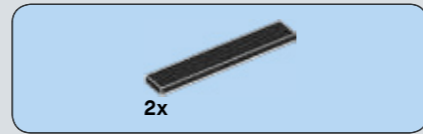
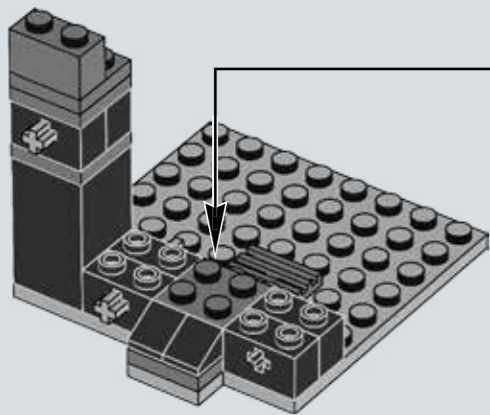
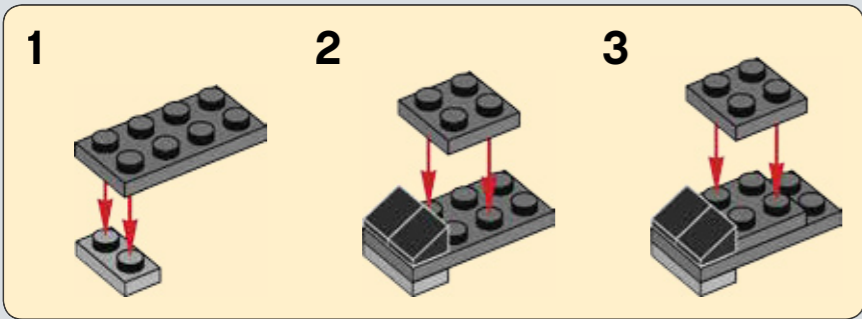

# 364

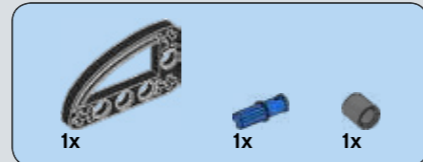
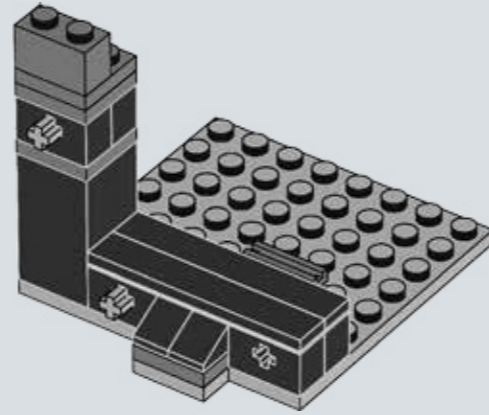

# 365

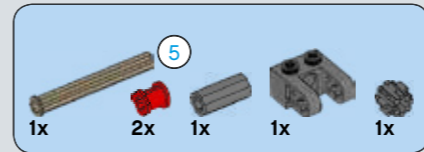
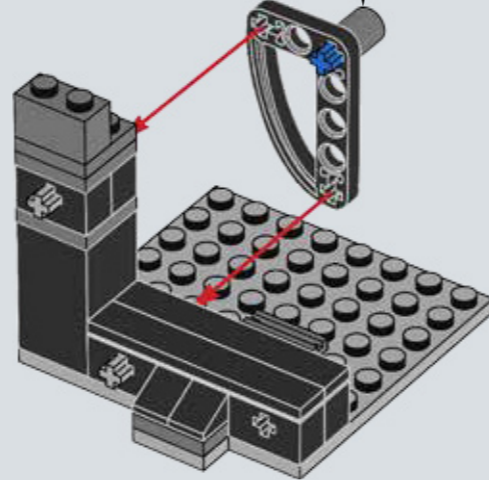
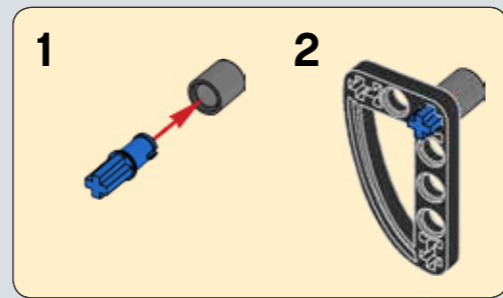

# 366

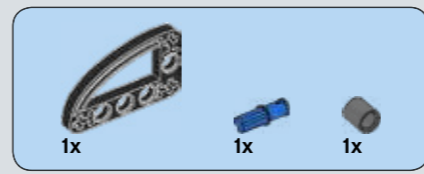
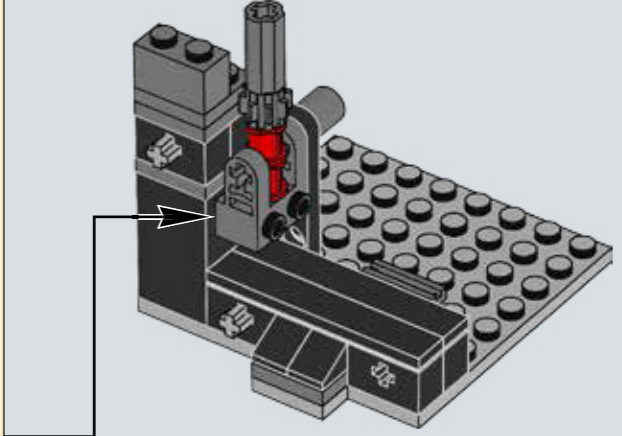
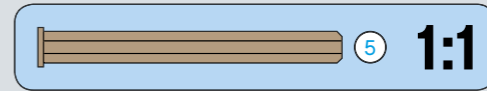
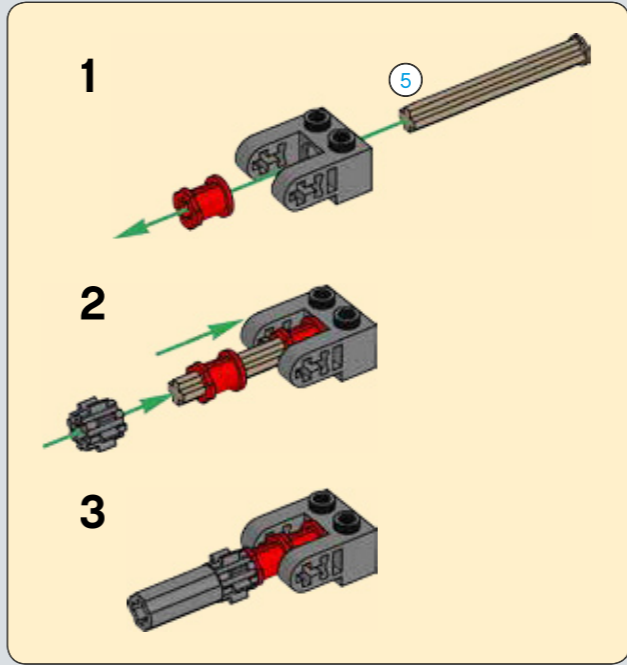

# 367

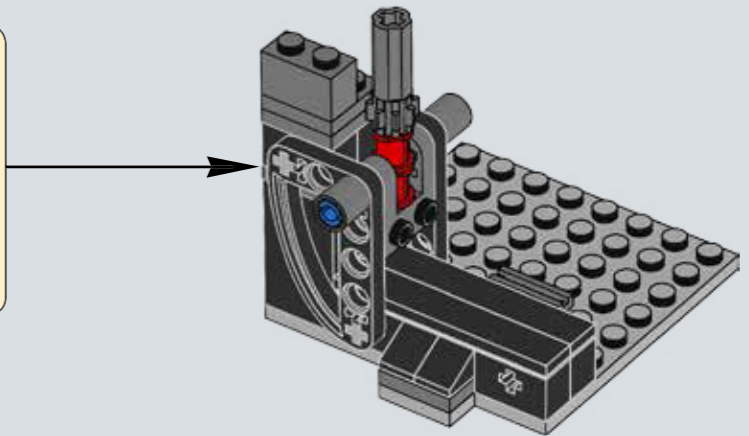
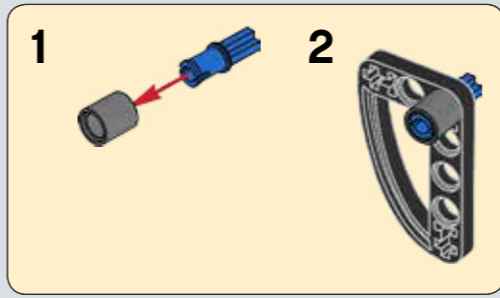



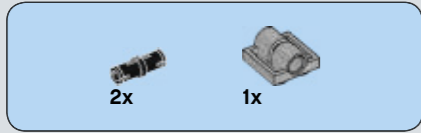
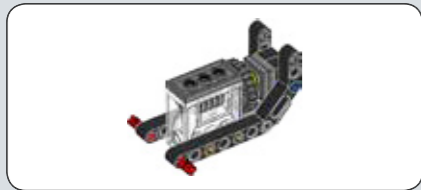

368

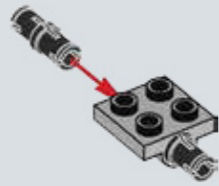

369

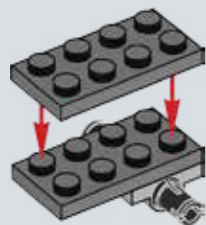

370

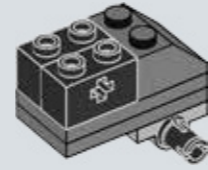

371

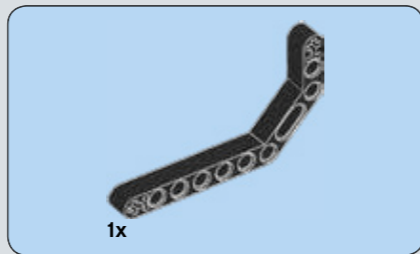
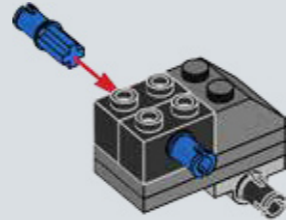

372

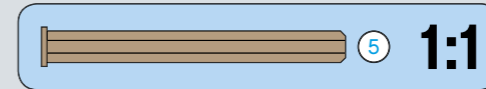
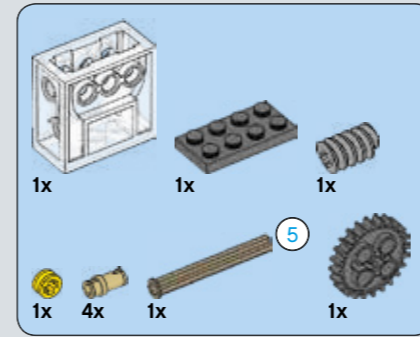
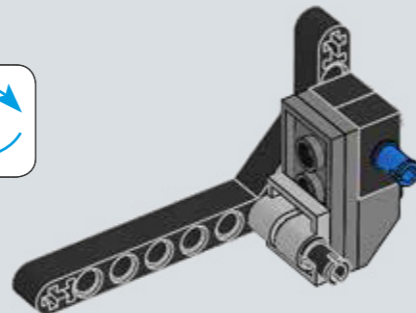
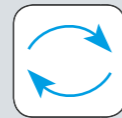

373

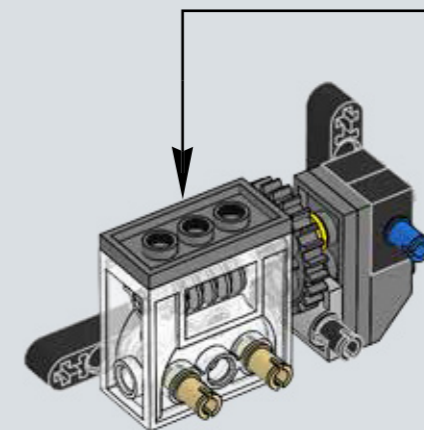
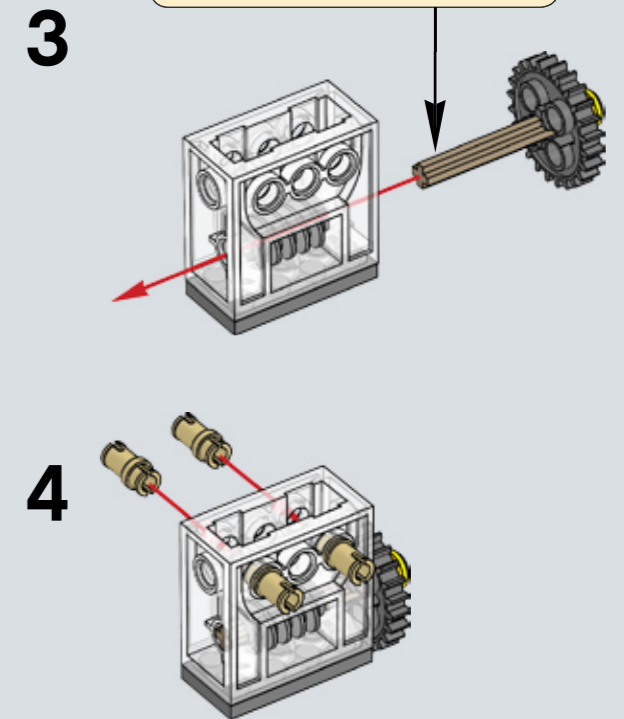
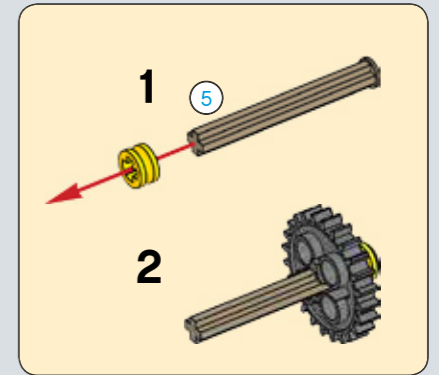
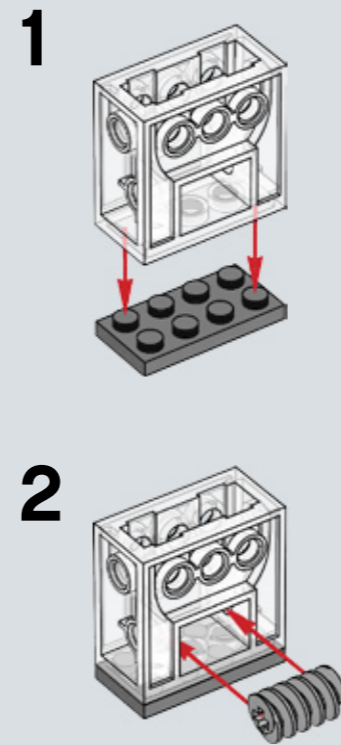

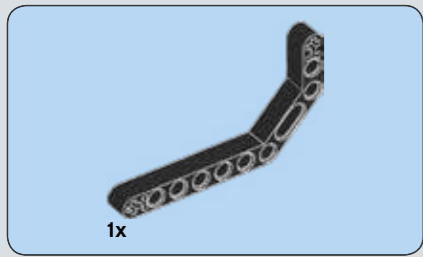

374

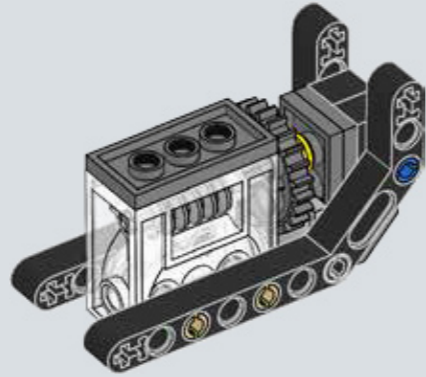

375

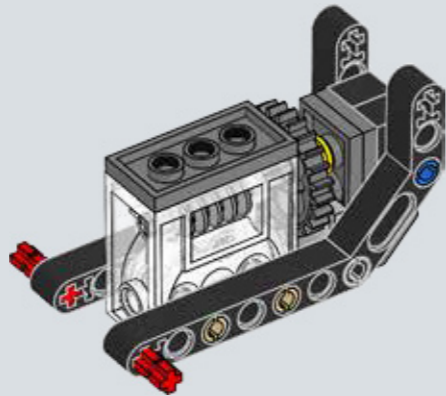

376

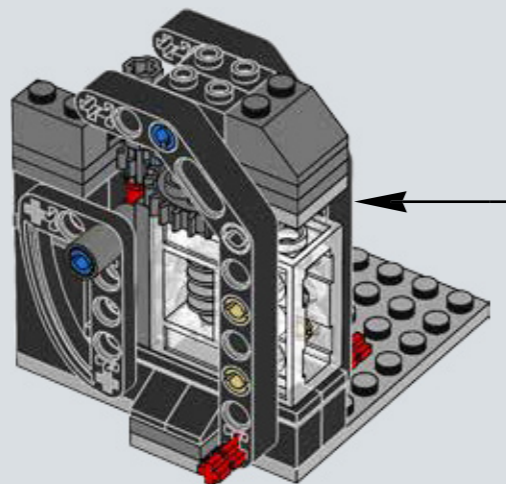

377

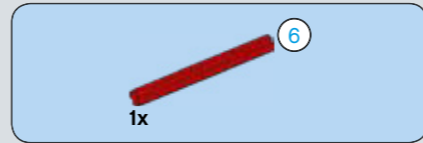
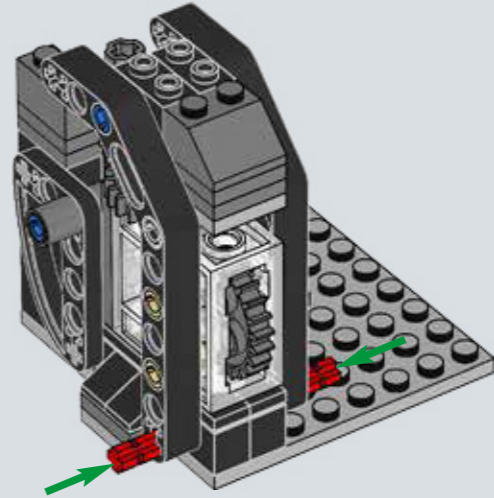

378

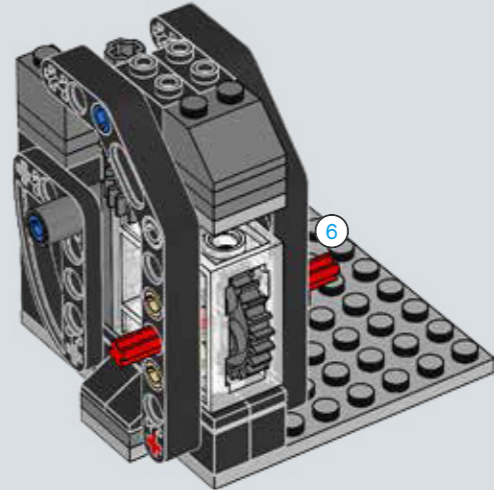

379

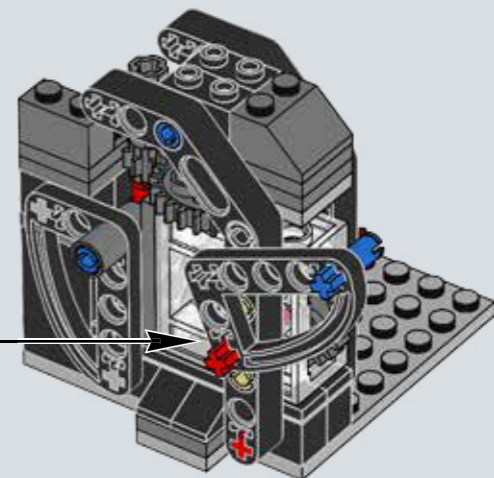
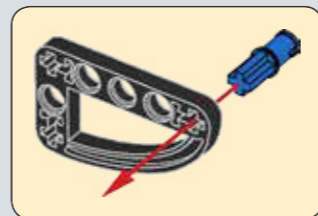

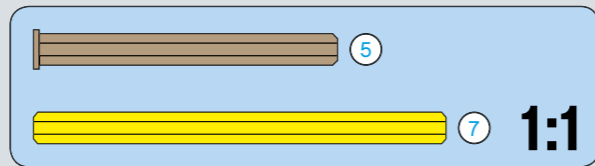
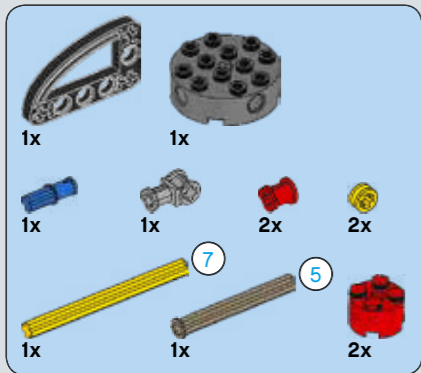

# 380

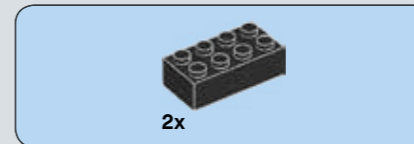
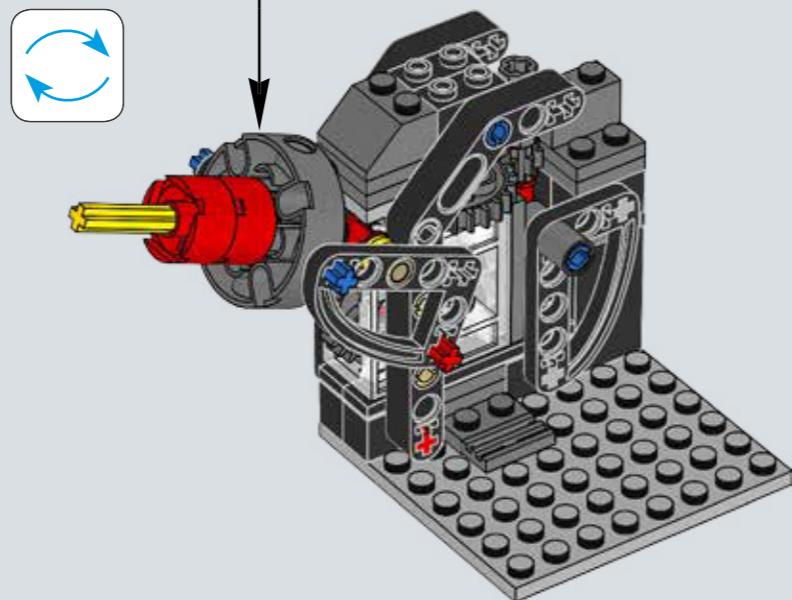
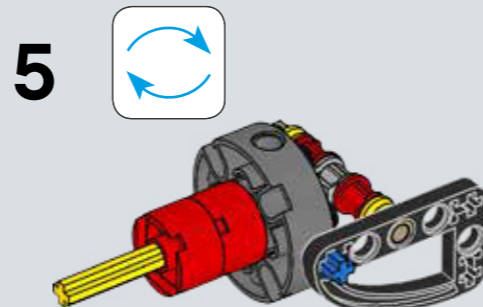
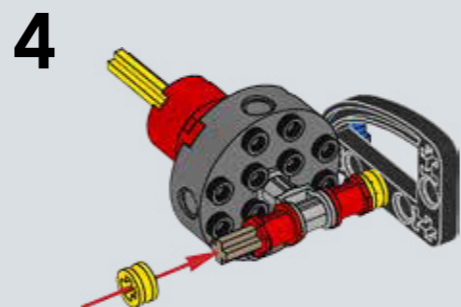
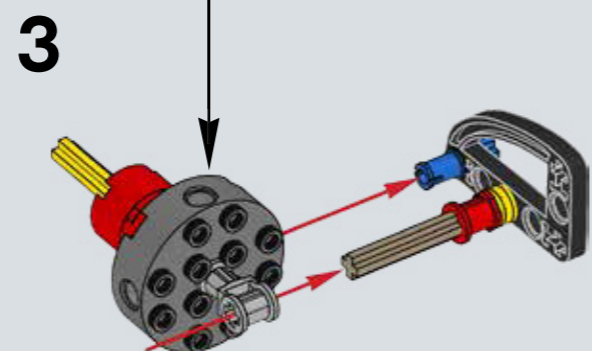
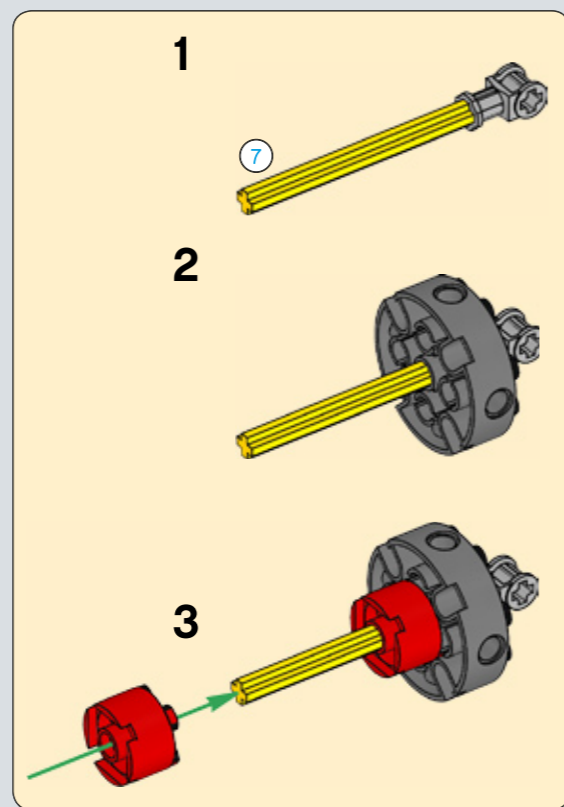
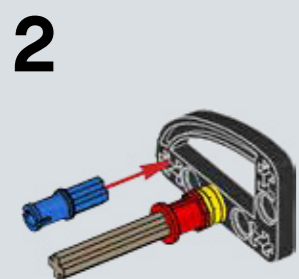
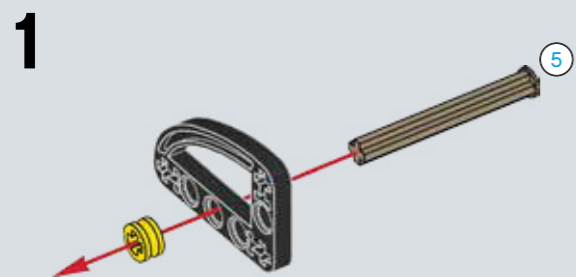

# 381

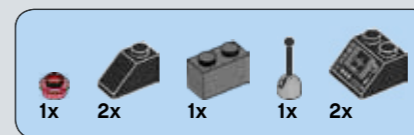
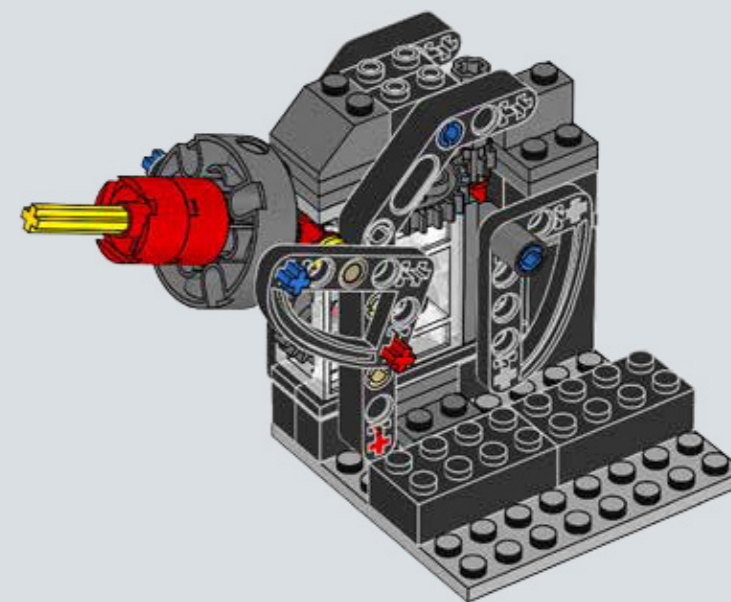

# 382

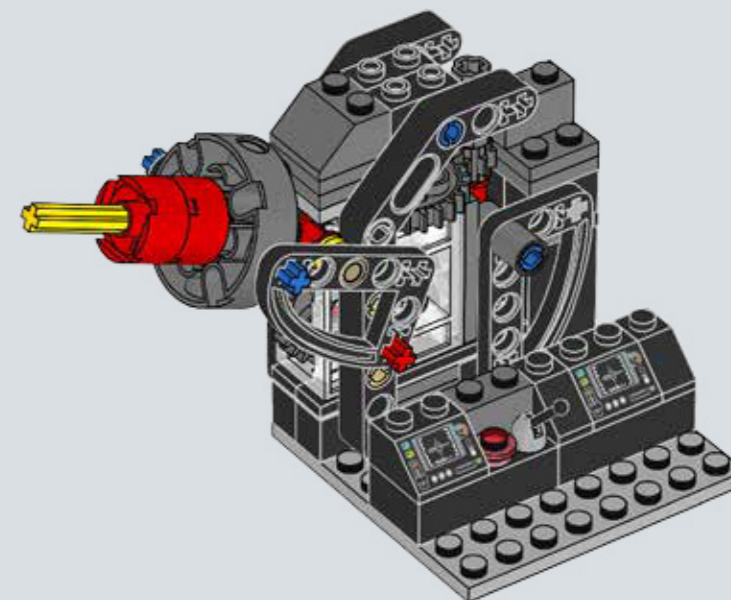

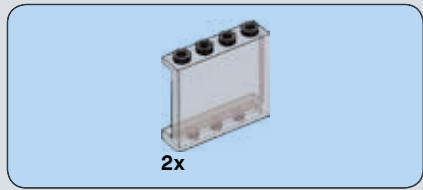

383

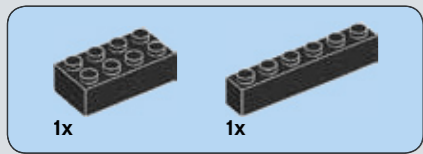
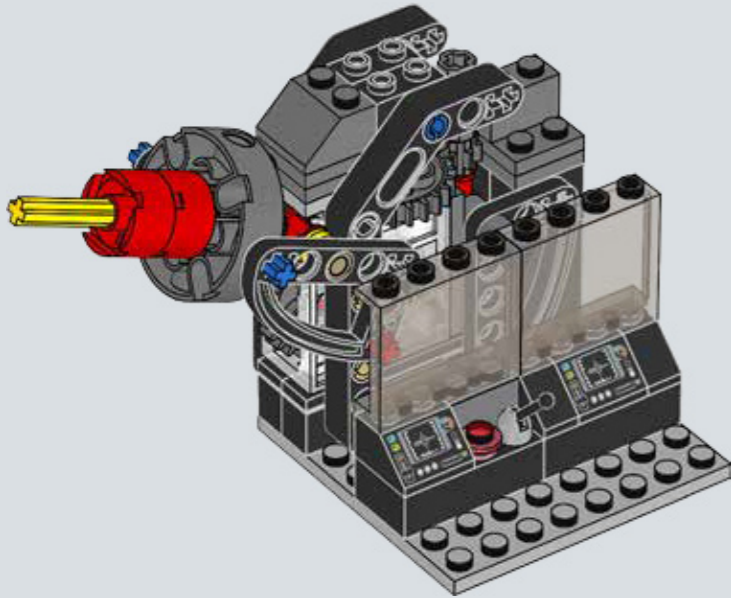

384

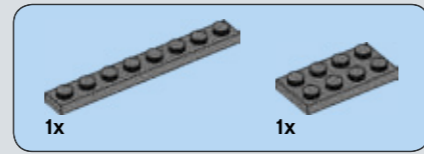
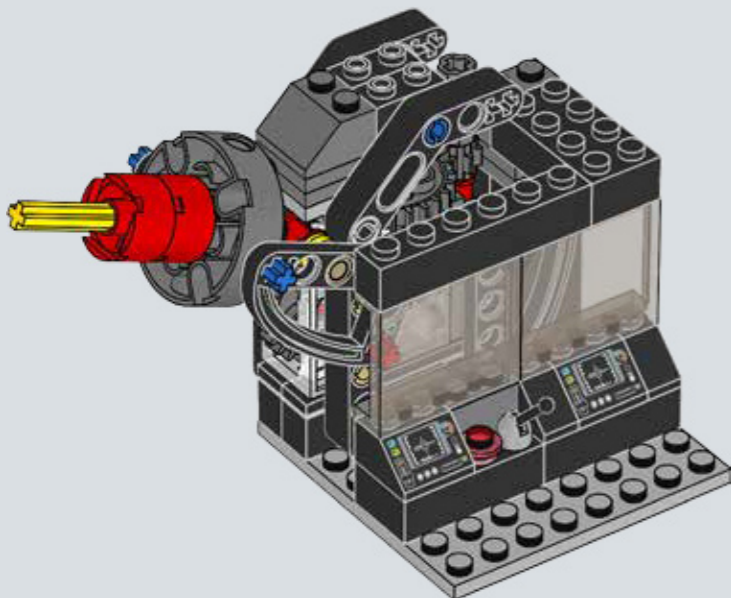

385

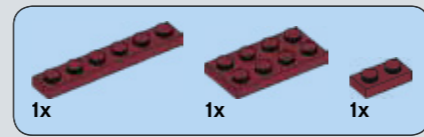
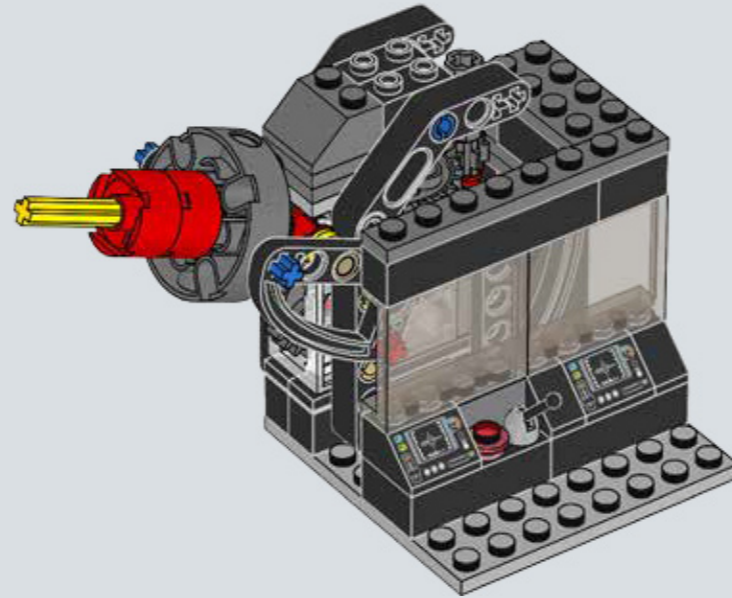

386

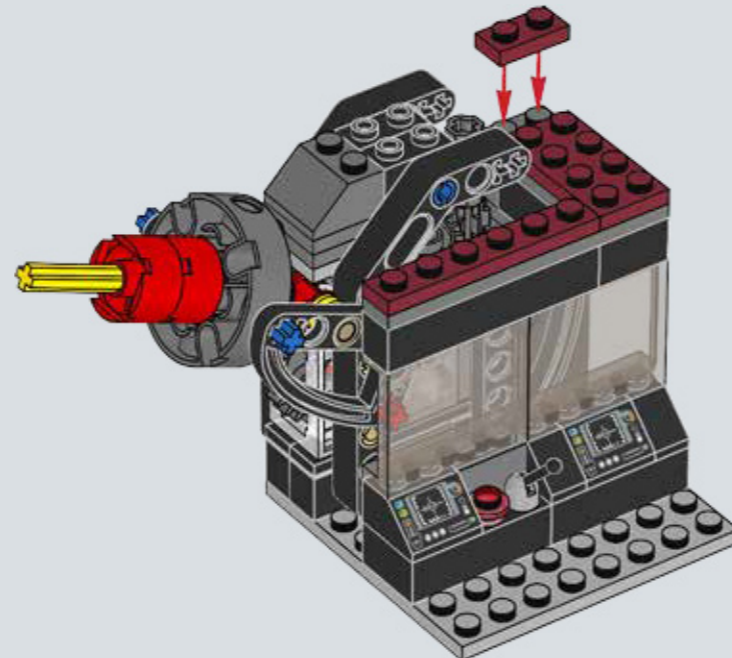

387

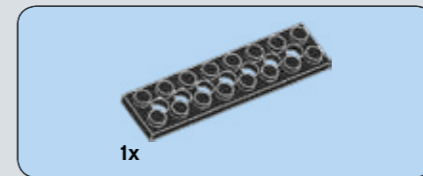
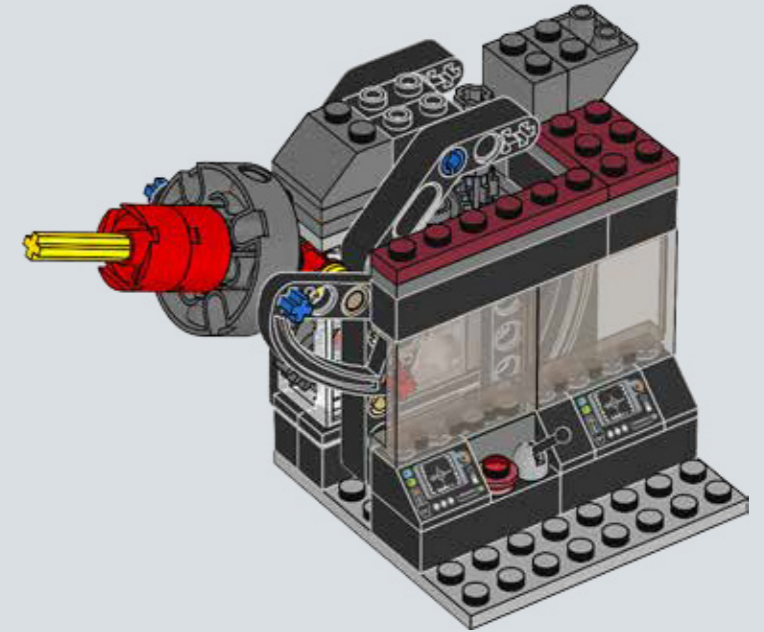

388

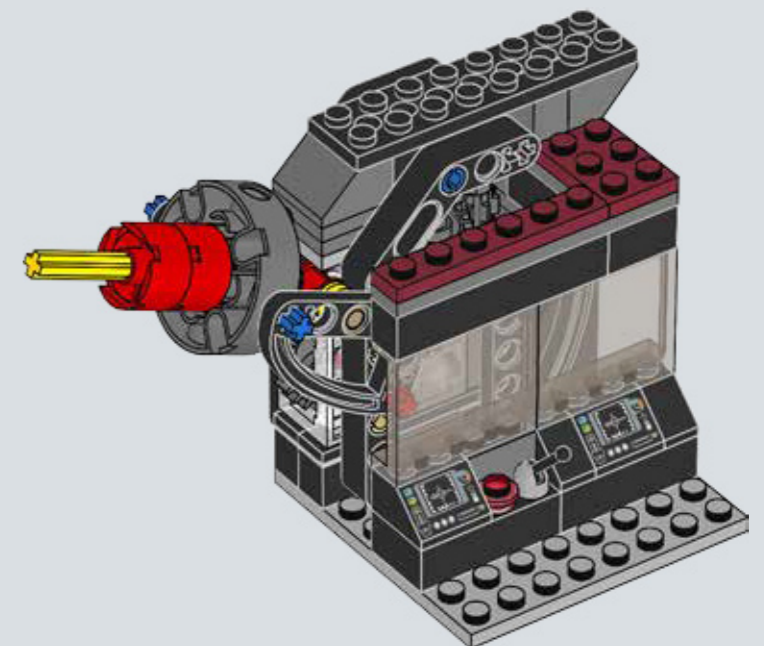

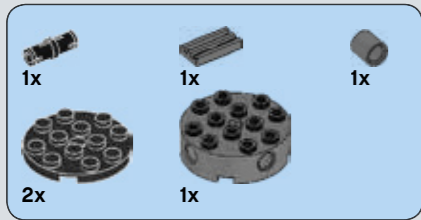

389

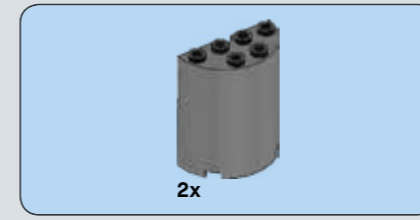
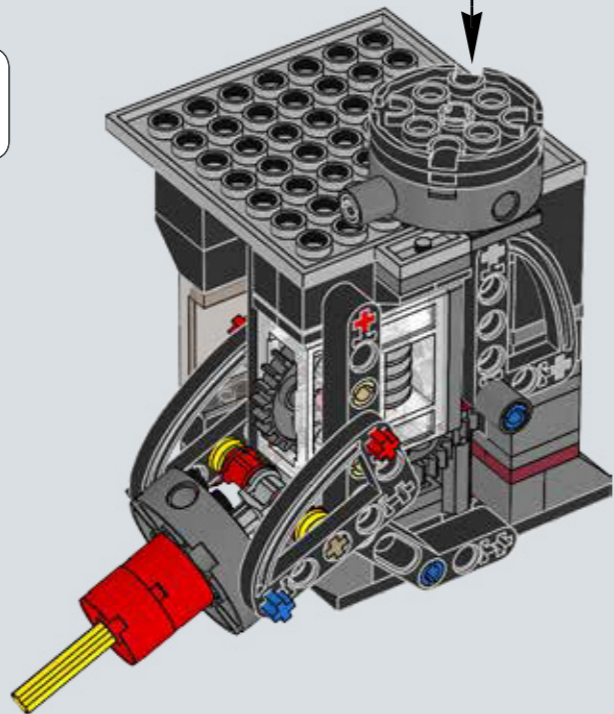
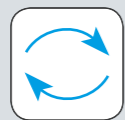
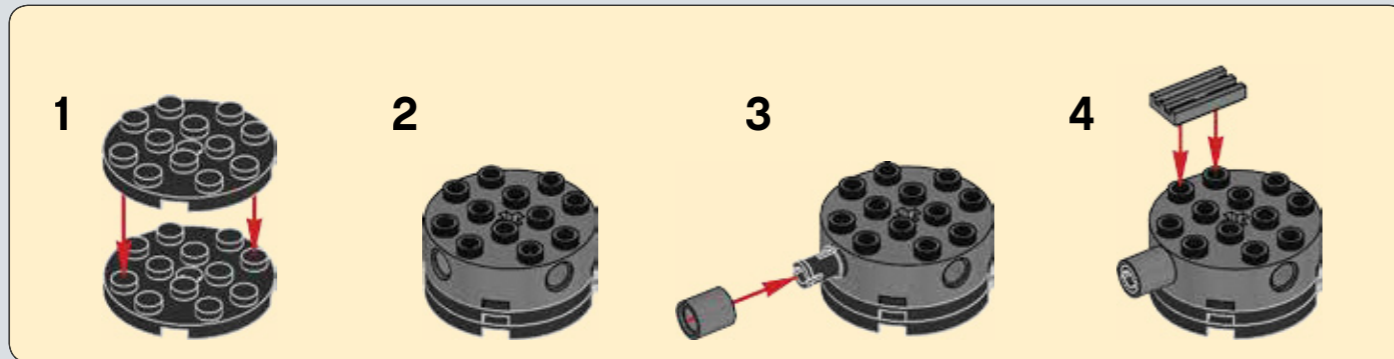

390

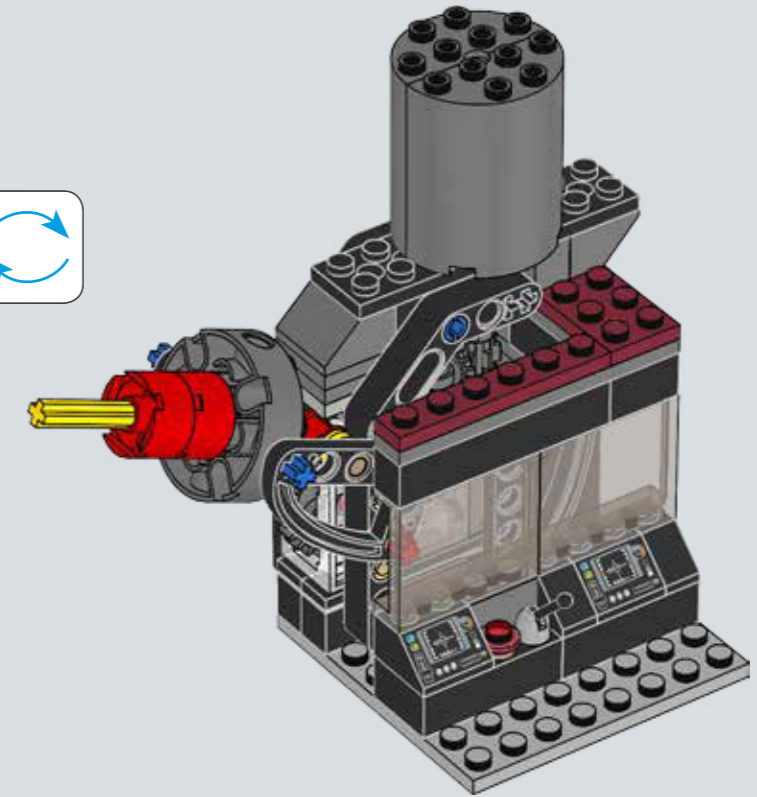
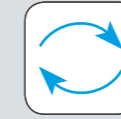

391

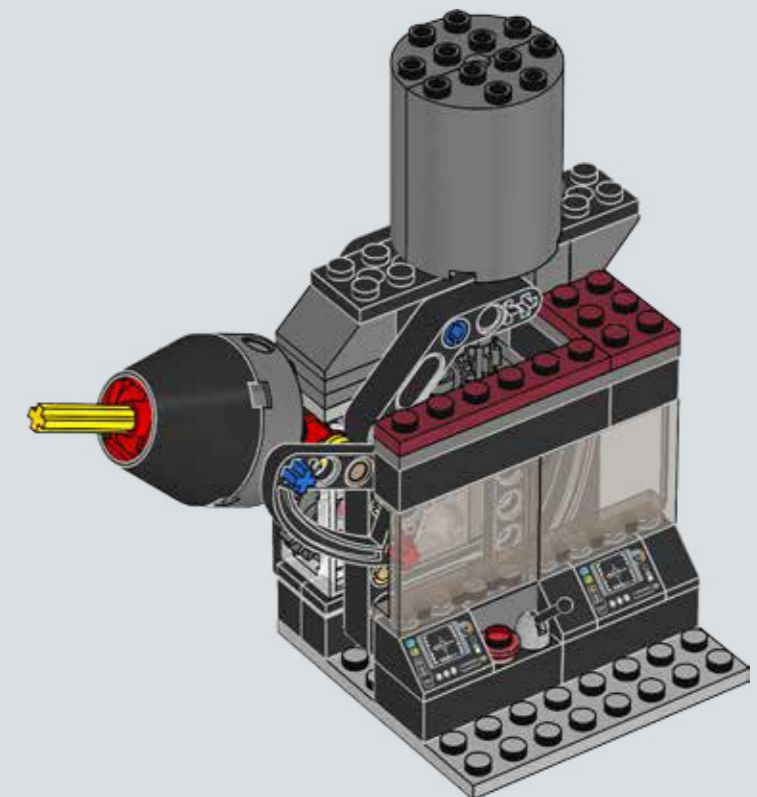

392

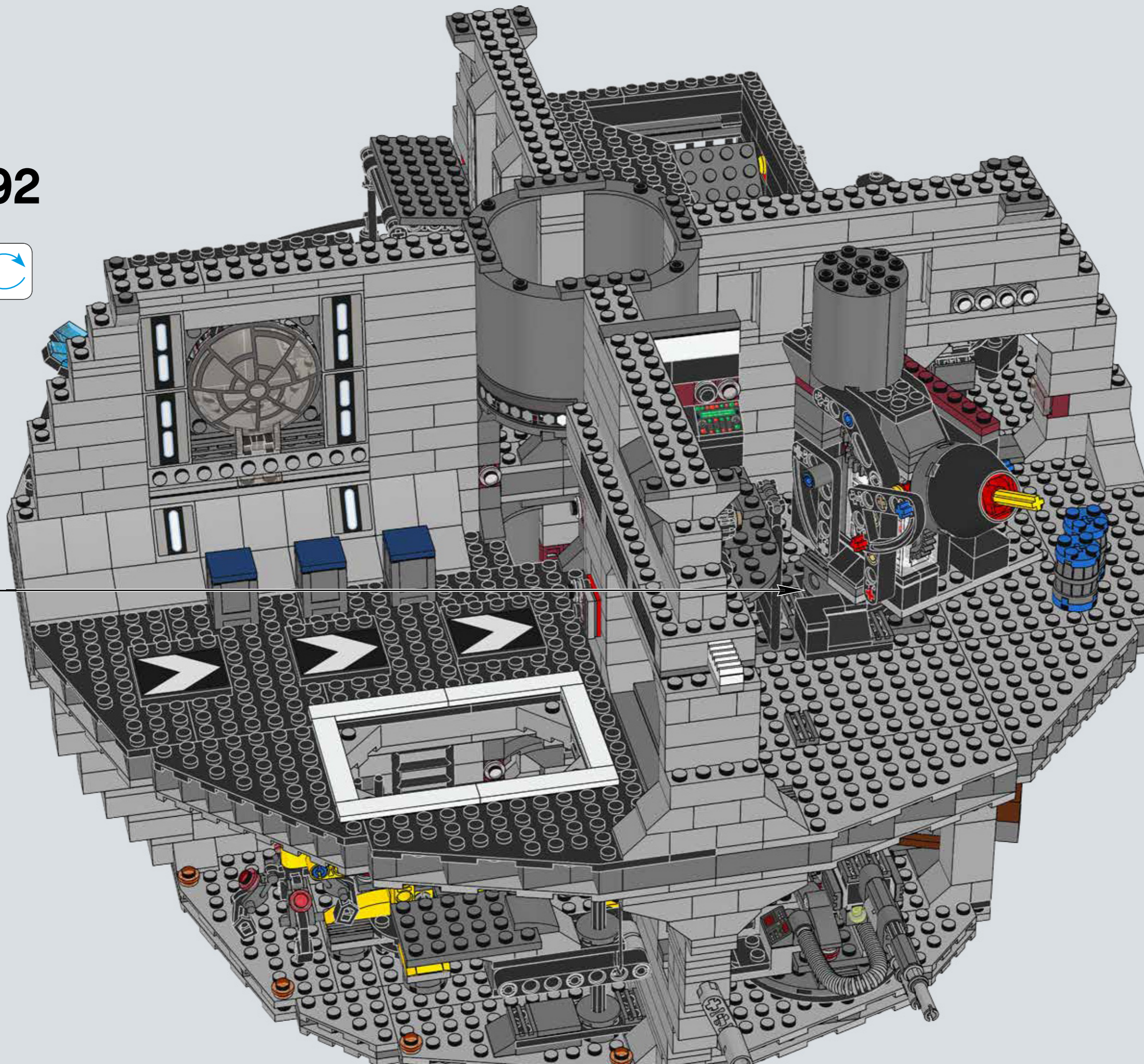
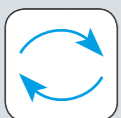

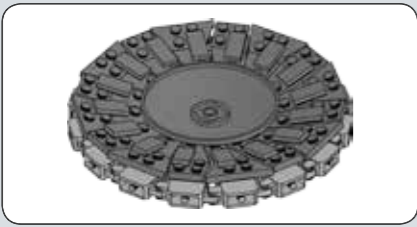

# 393

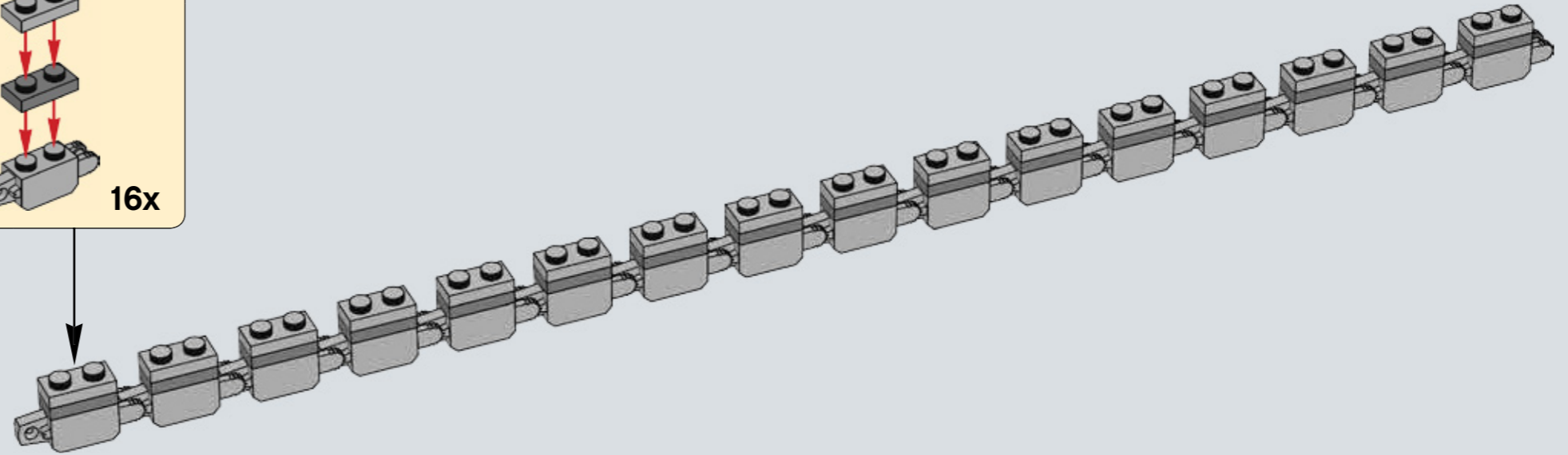
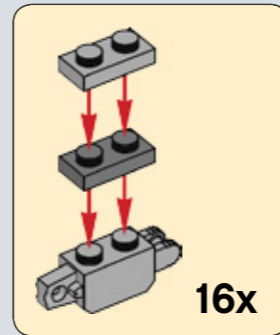

# 394

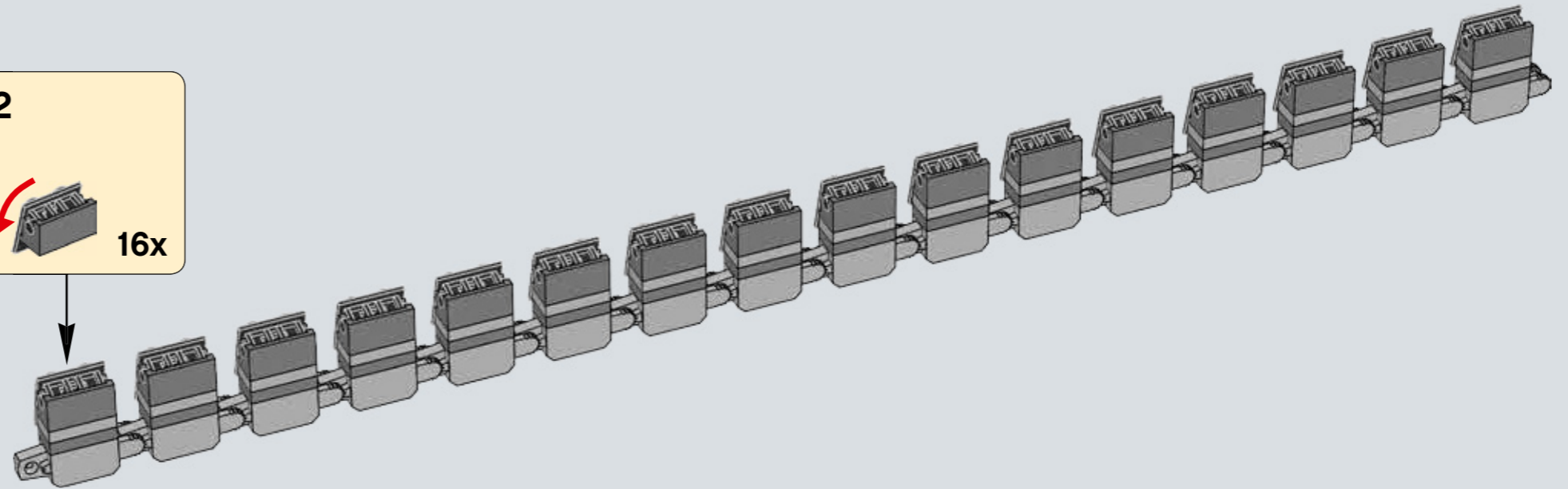
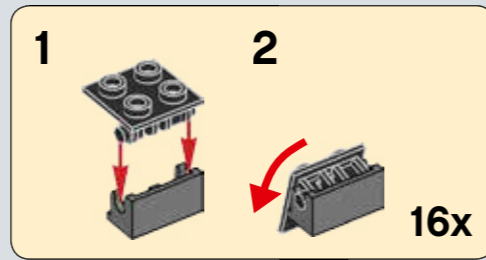

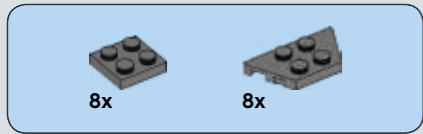

395

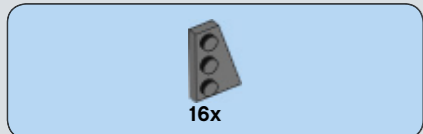
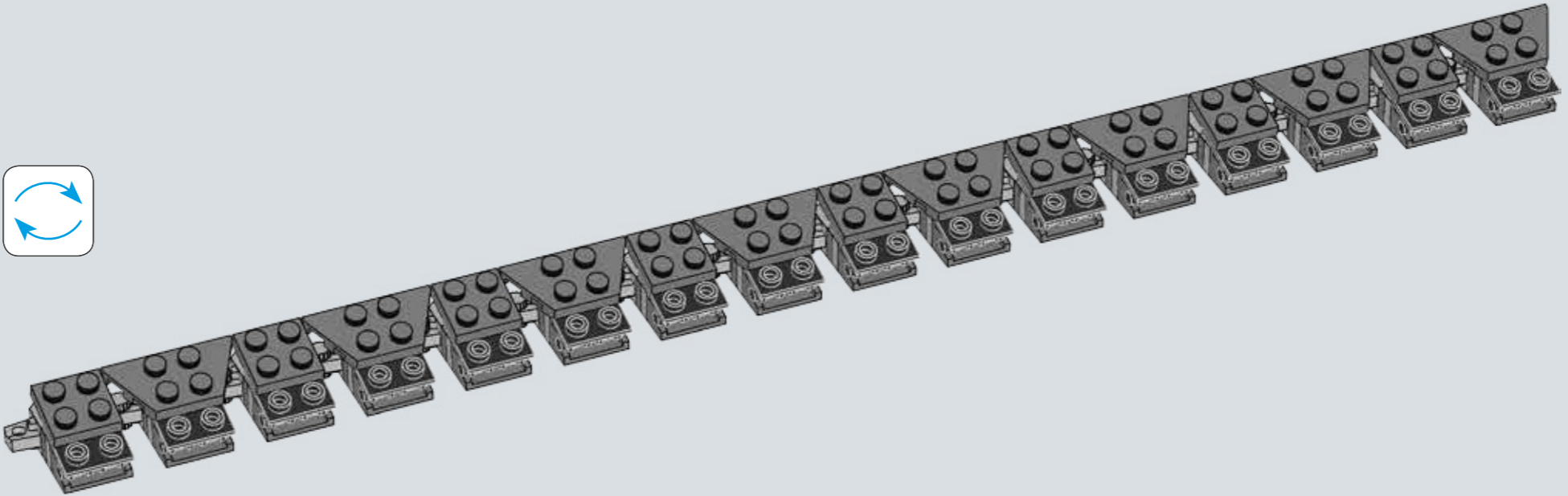

396

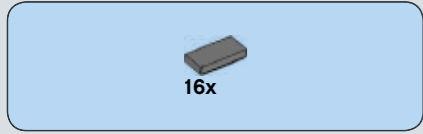
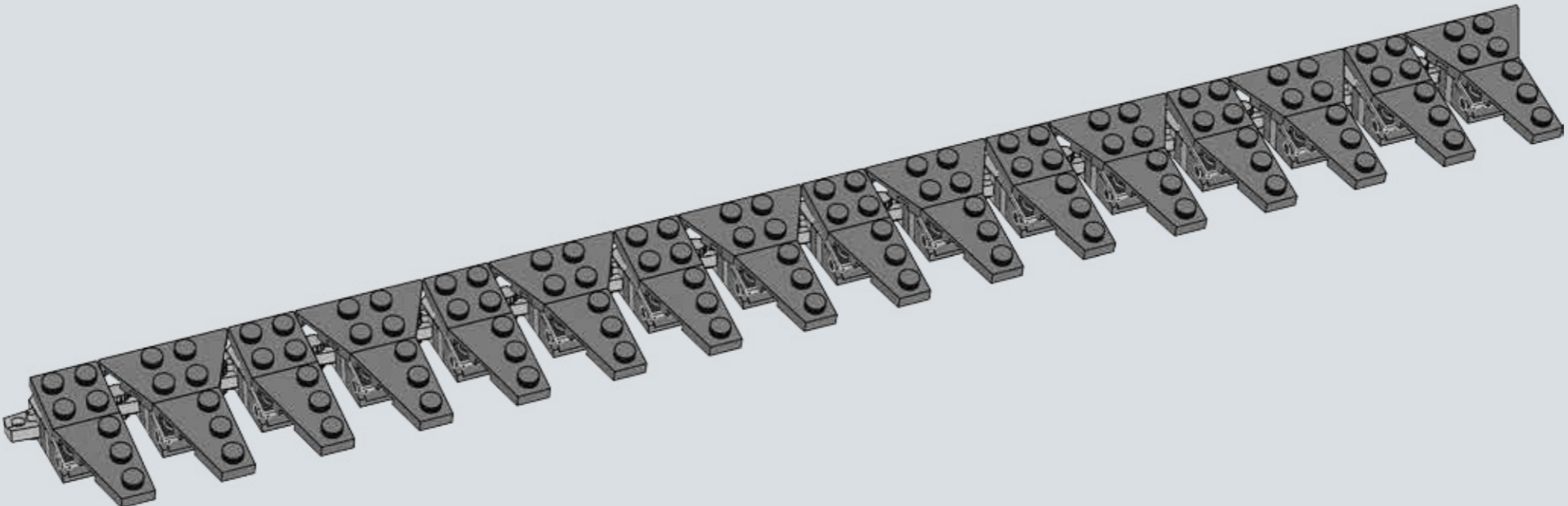

397

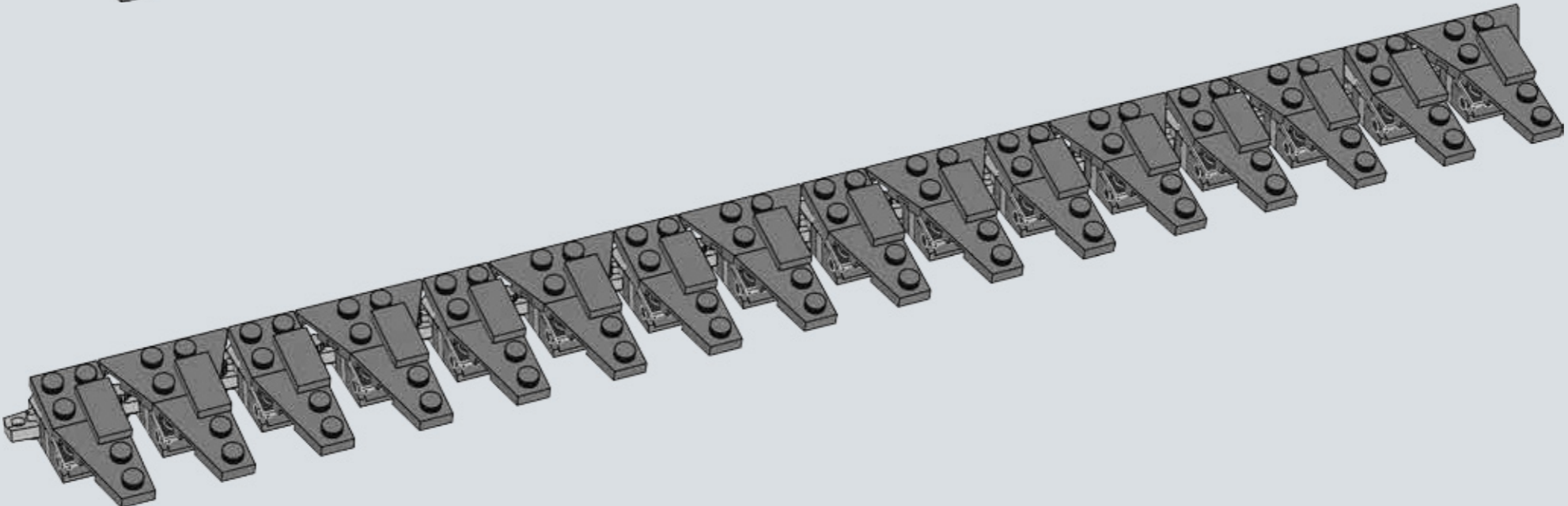



398

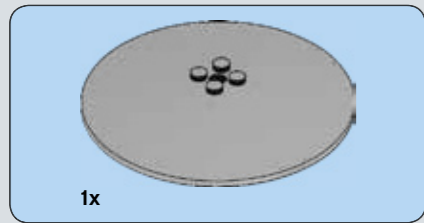
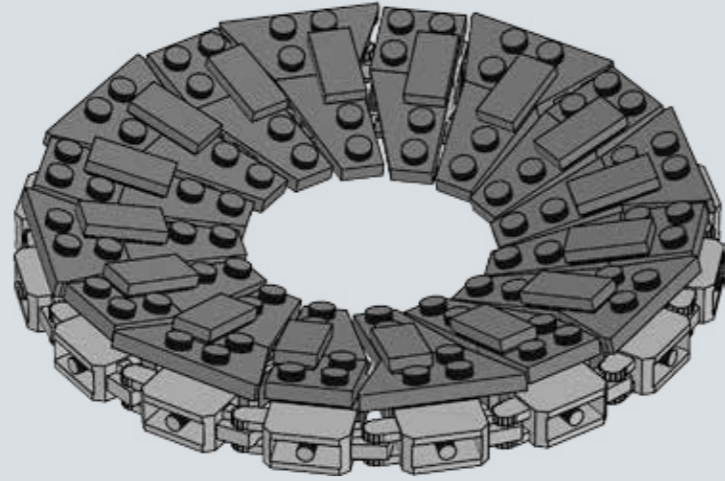

399

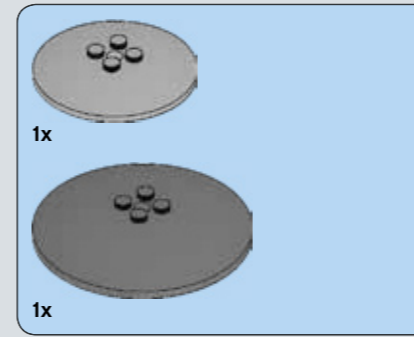
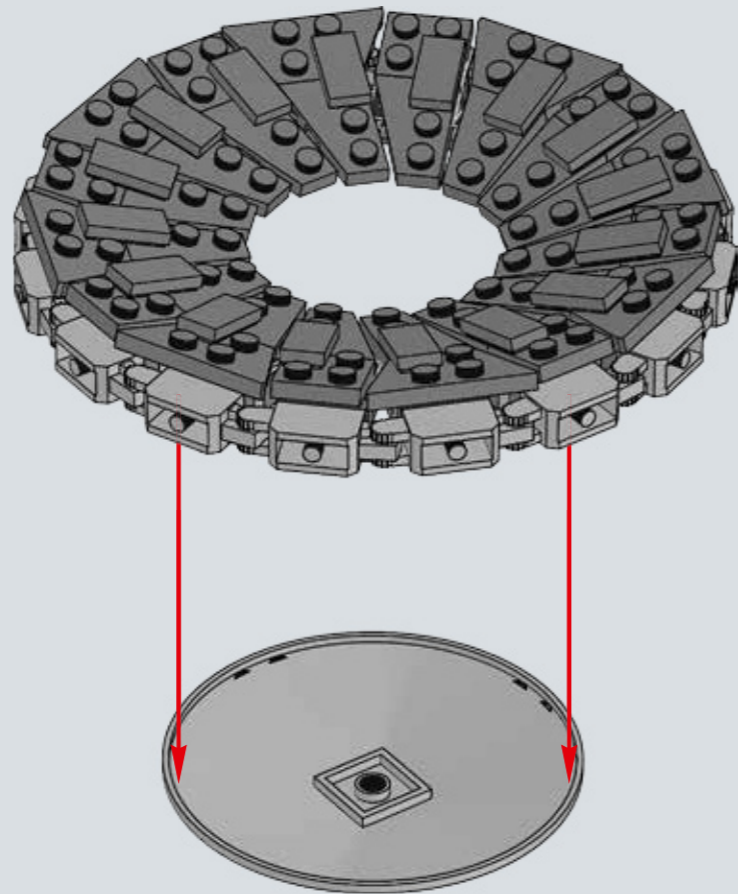

400

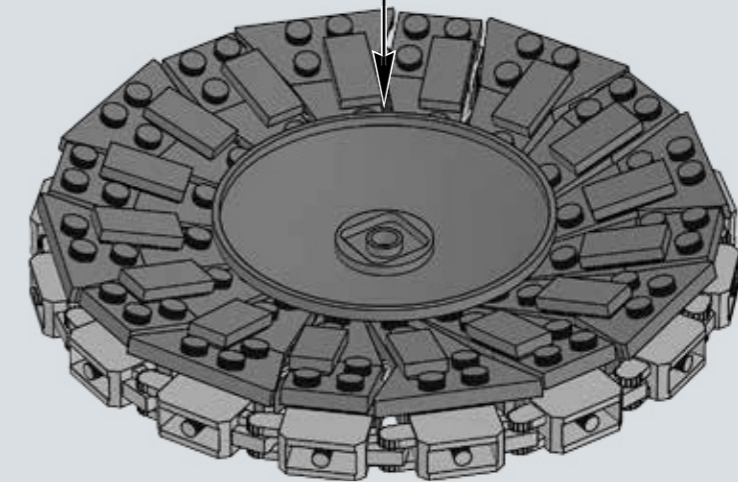
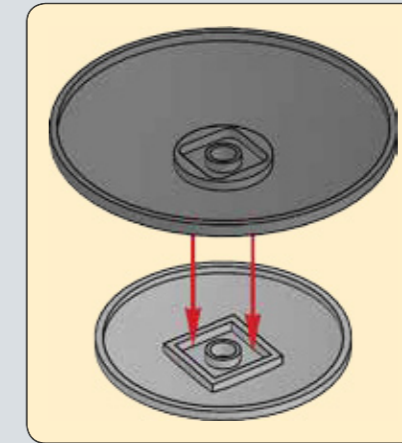

401

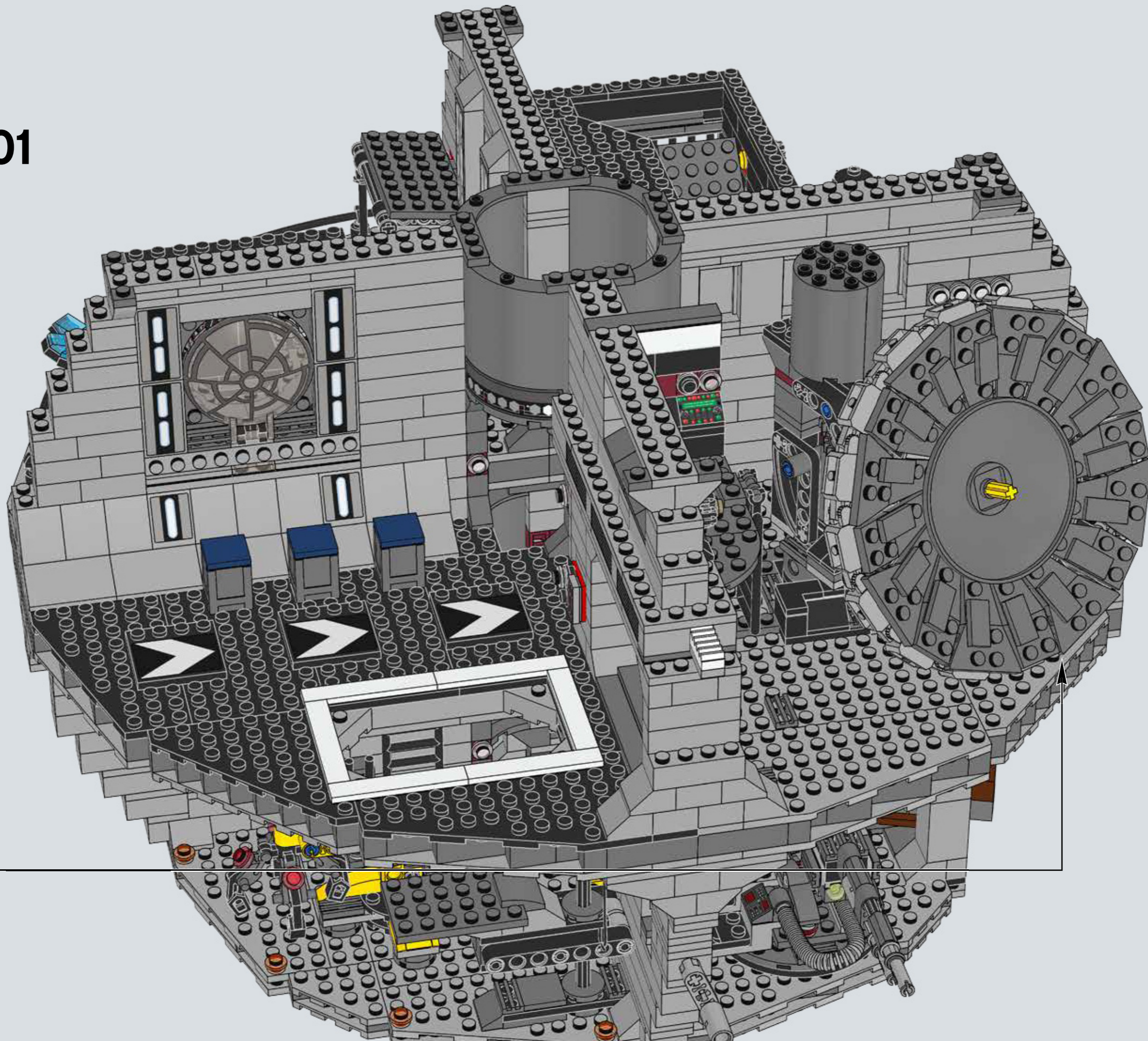

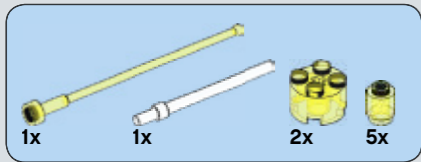

402

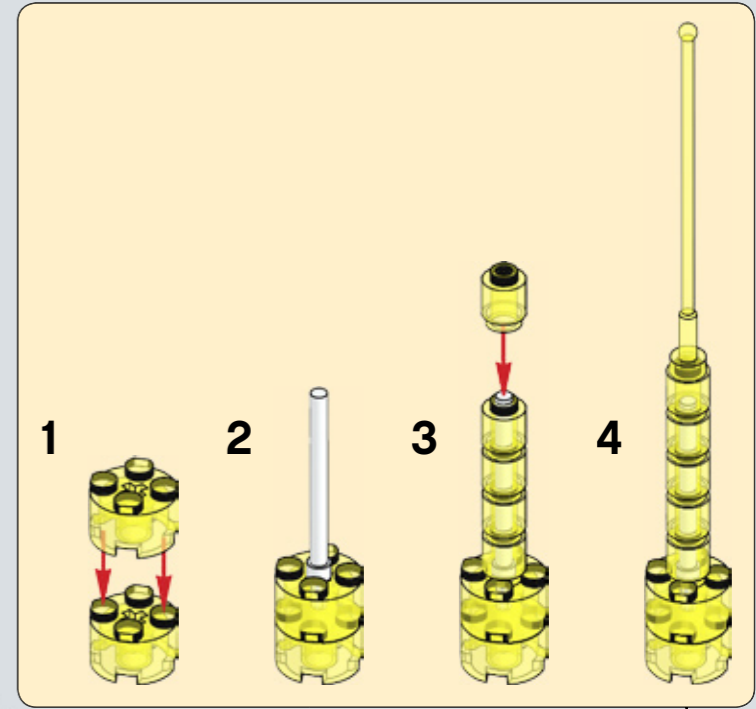
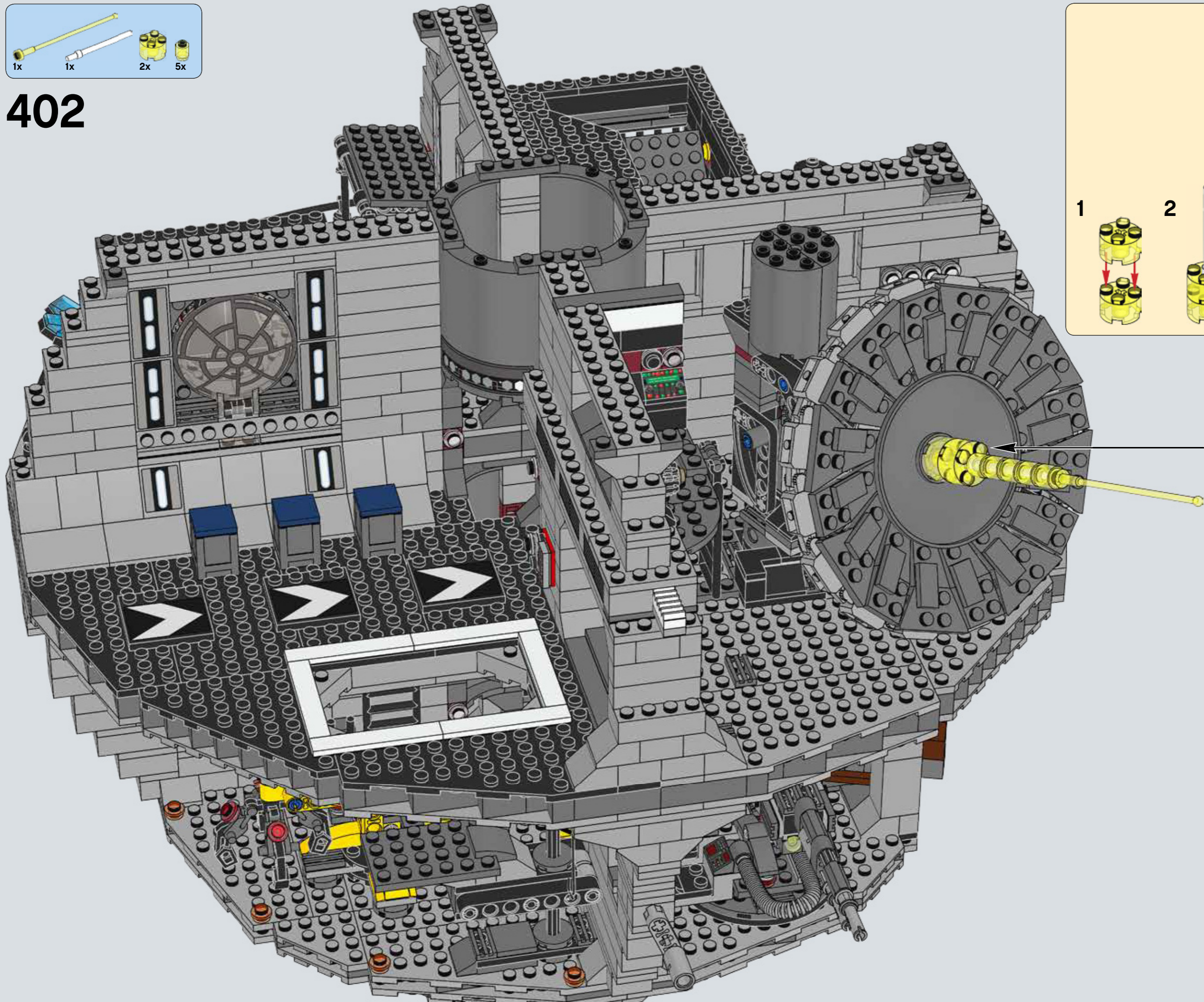

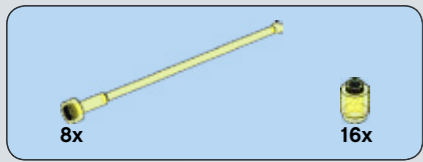

403

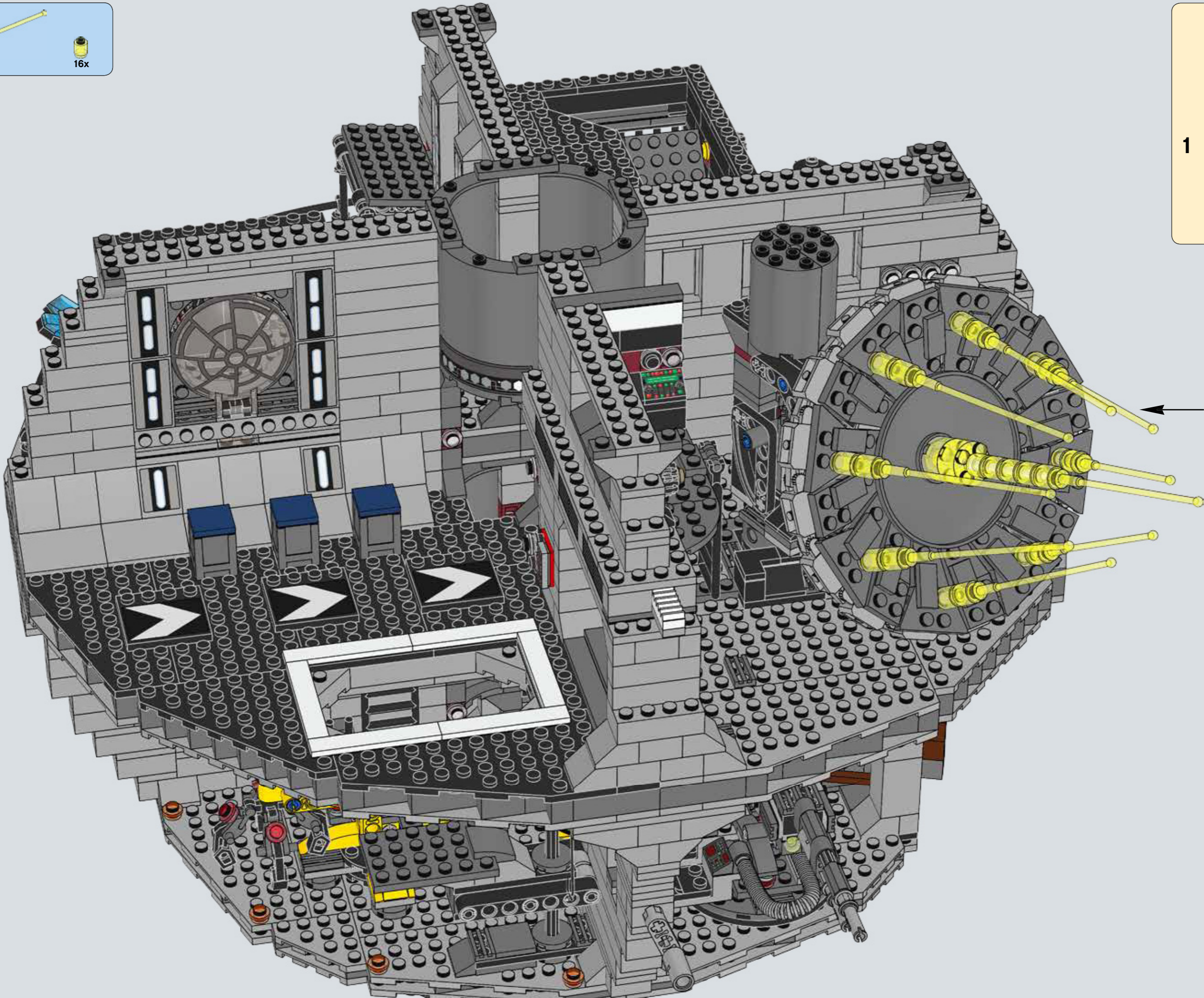
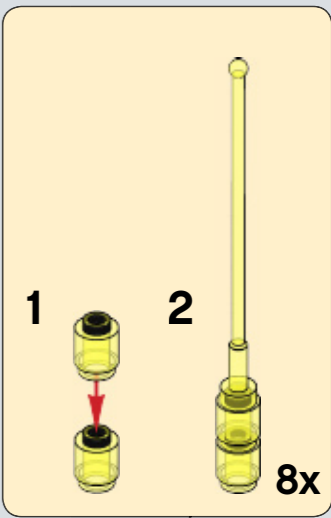

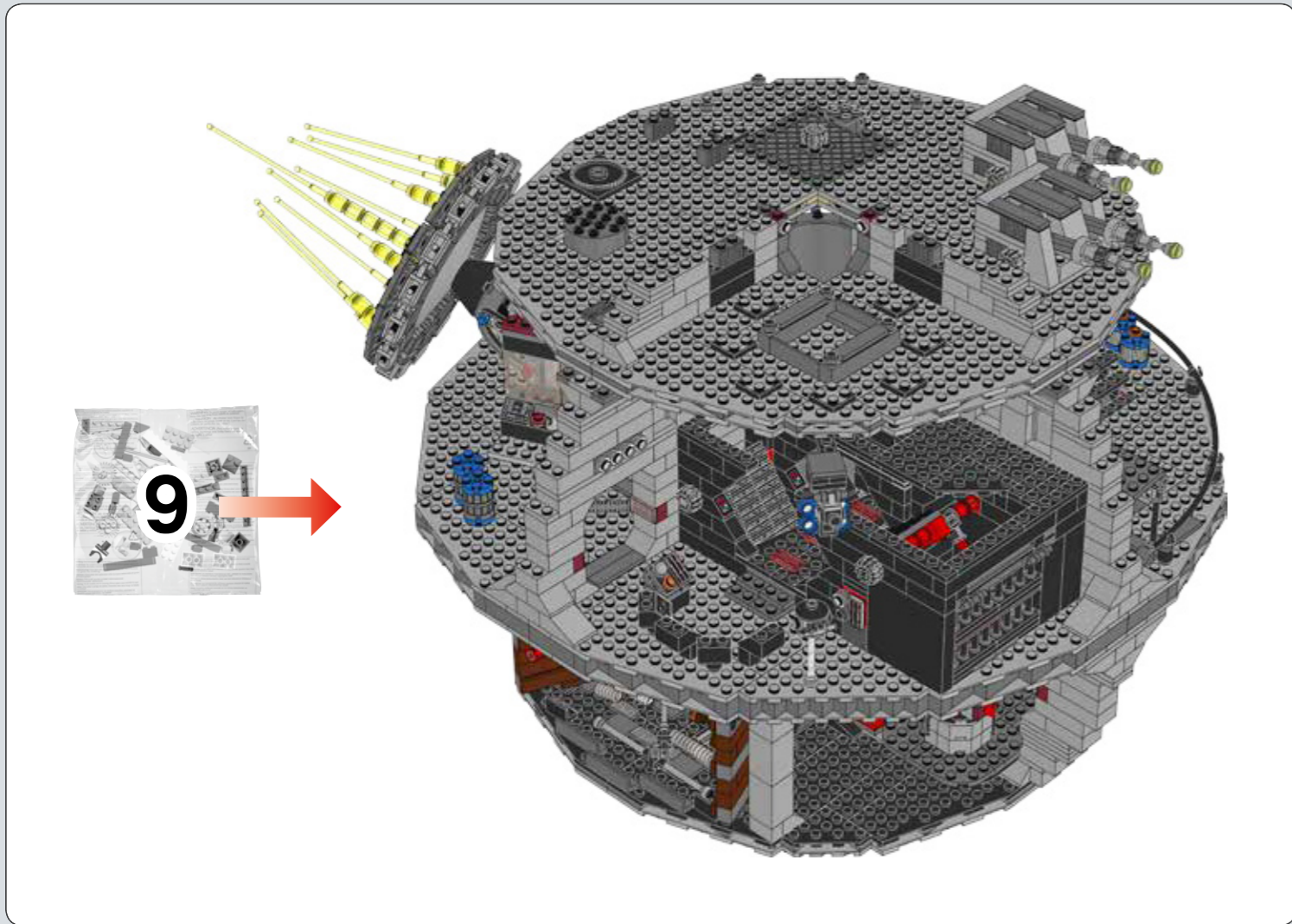

405

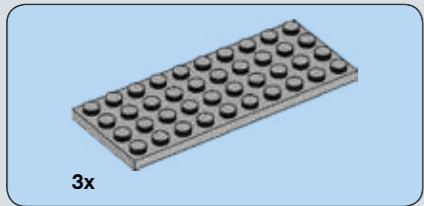
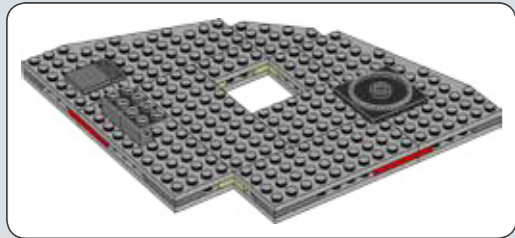
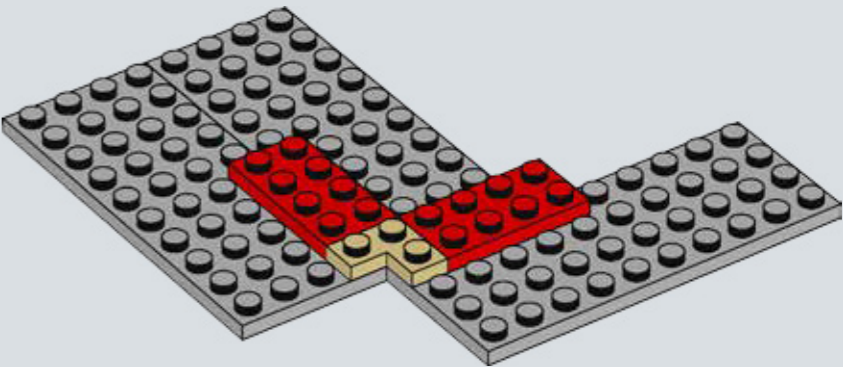

404

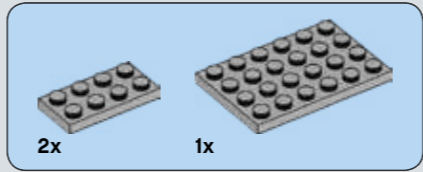
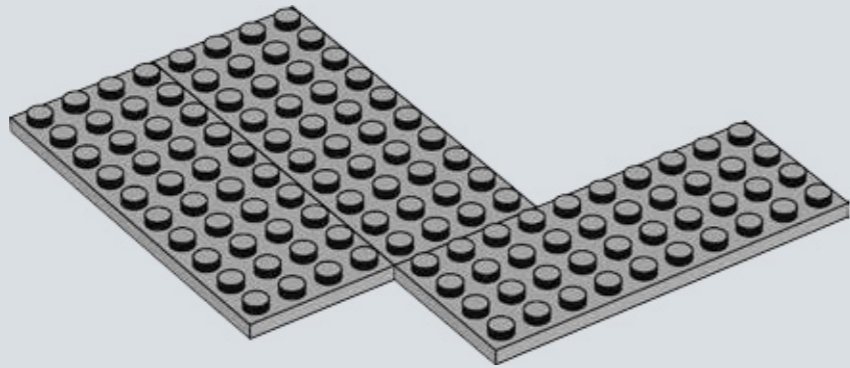

406

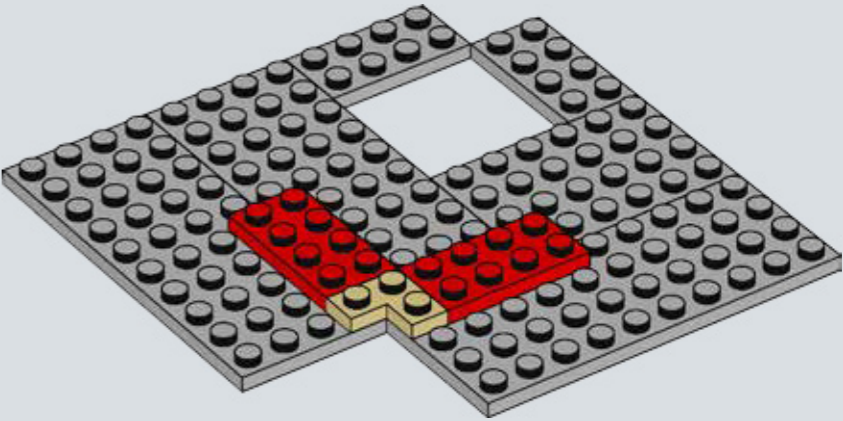



407

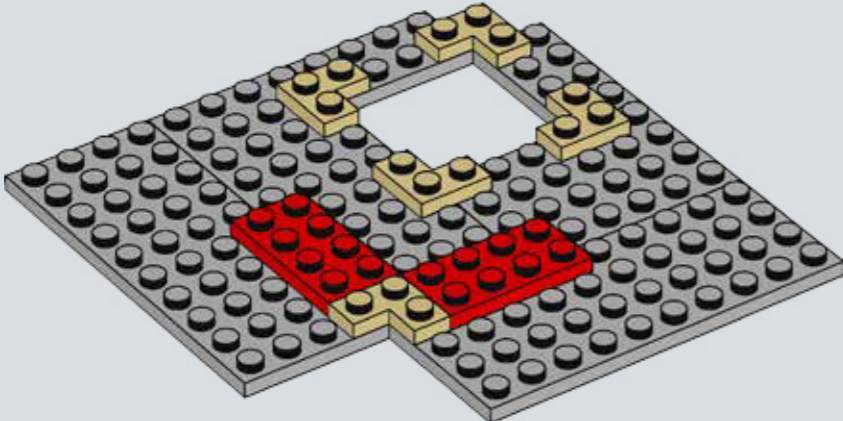

408

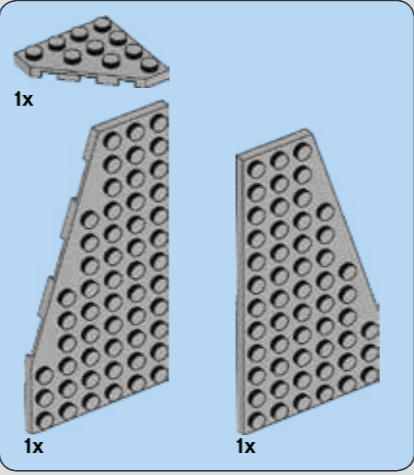
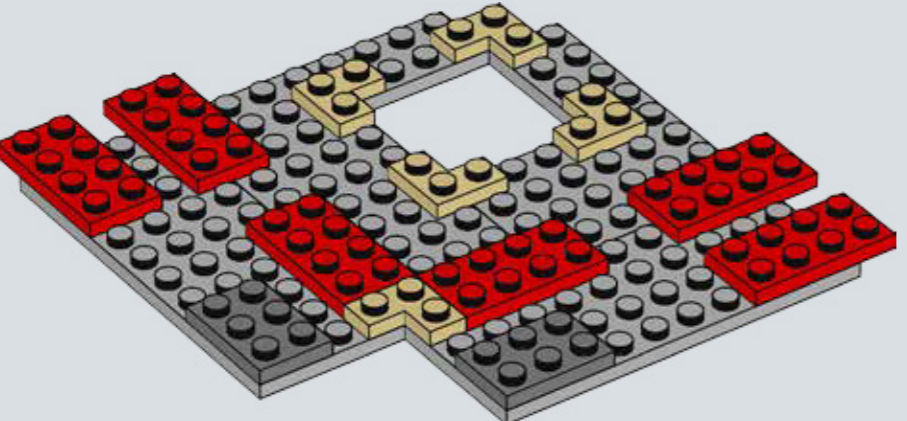

409

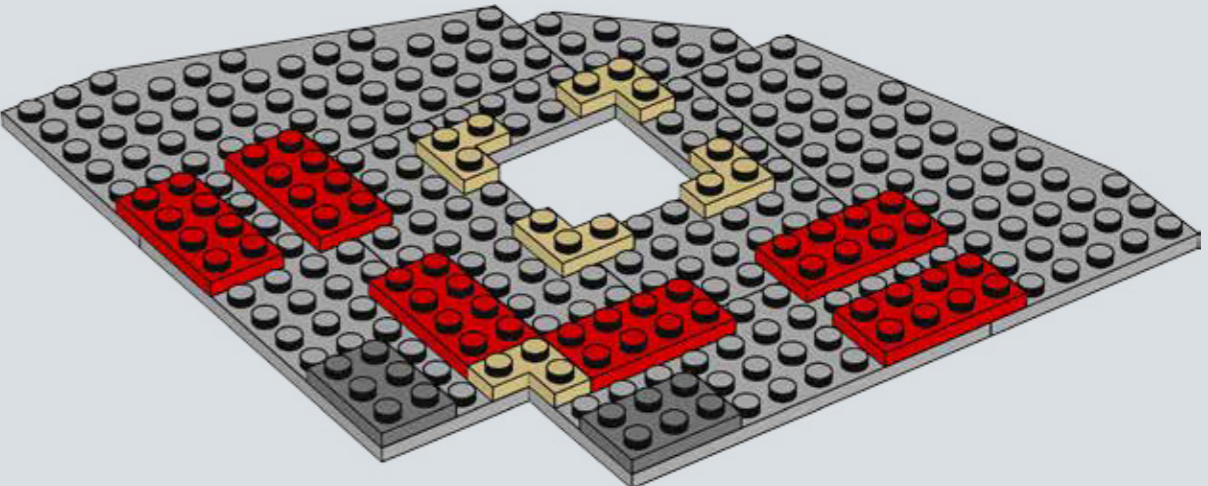

410

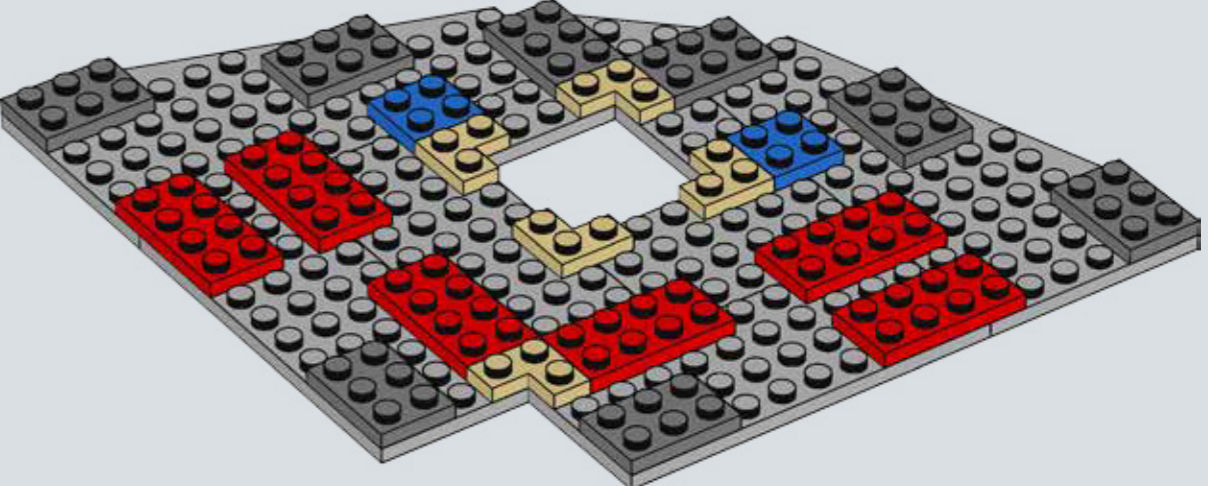

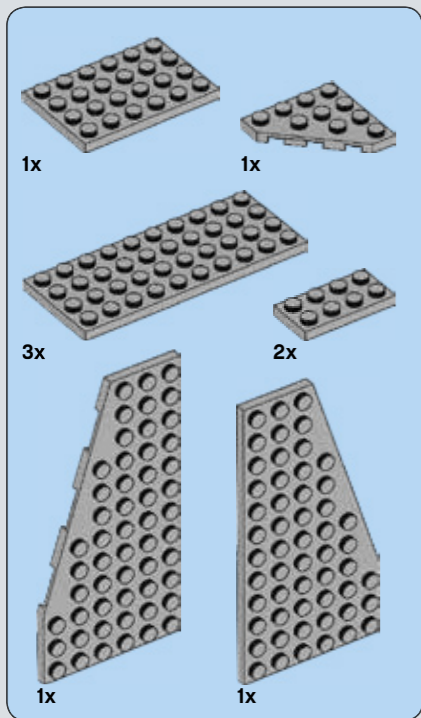

**411**

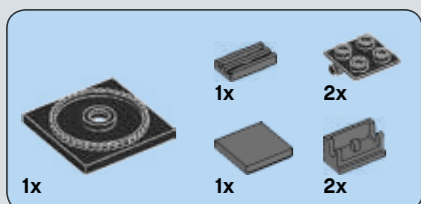
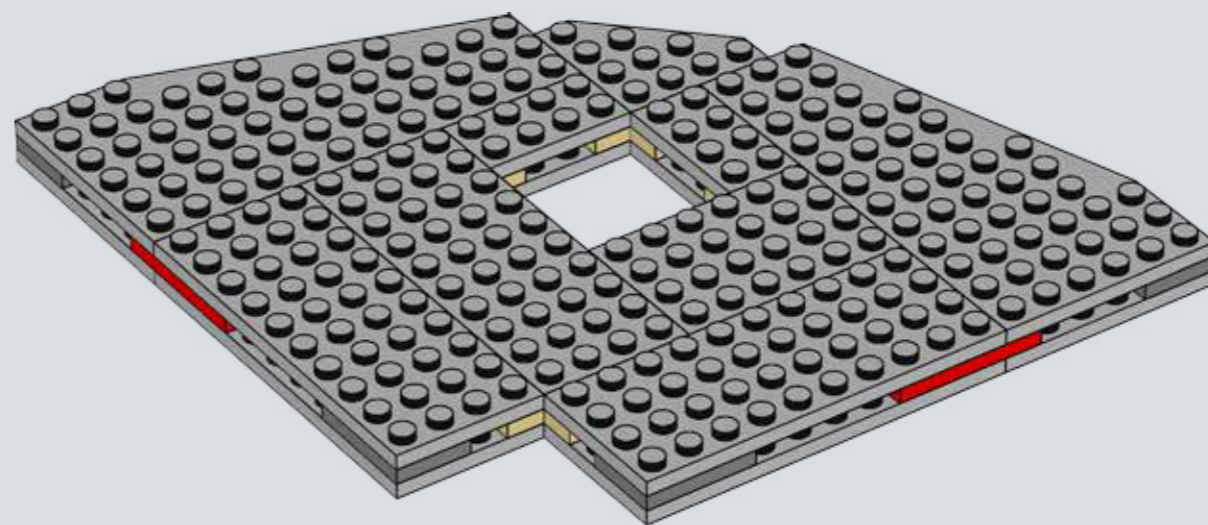

**412**

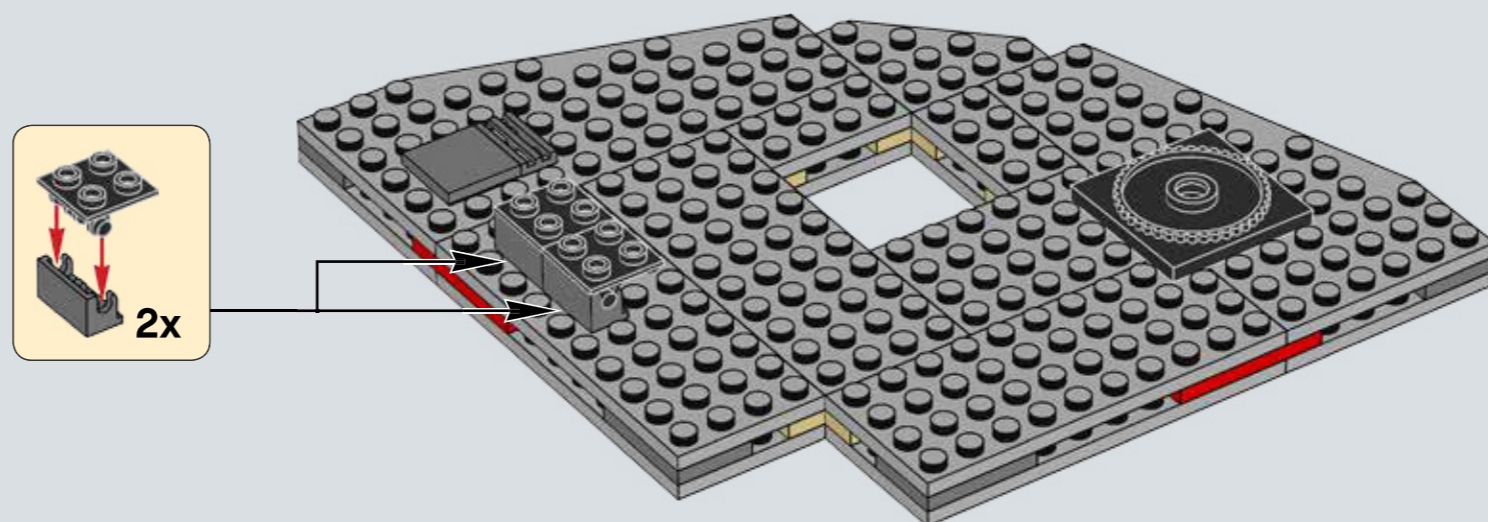

413

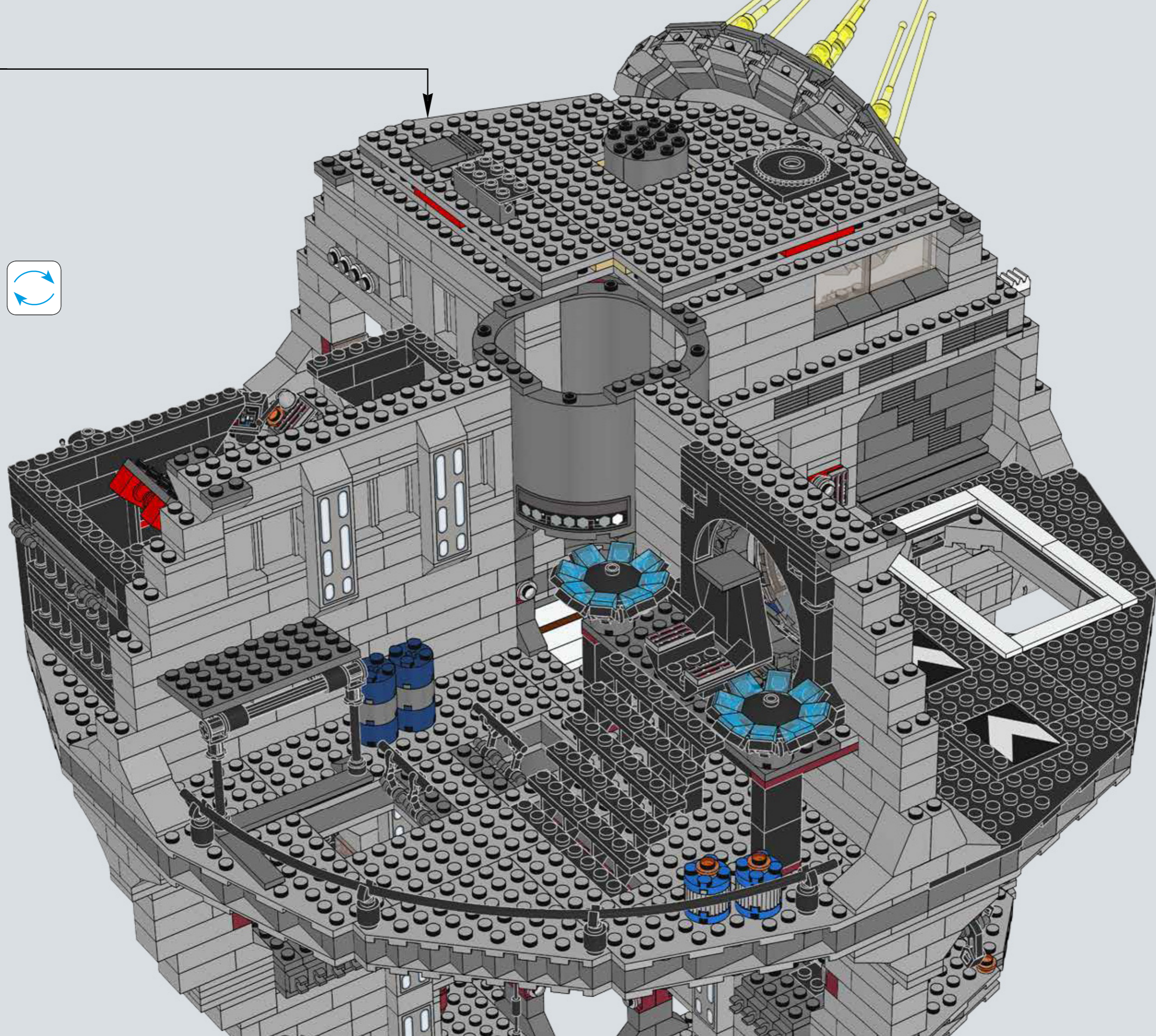



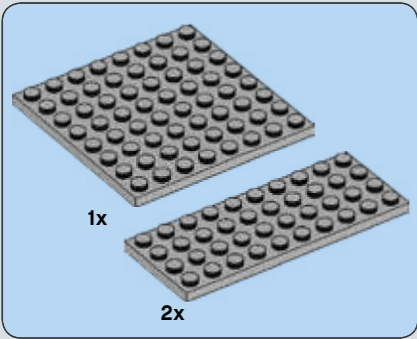
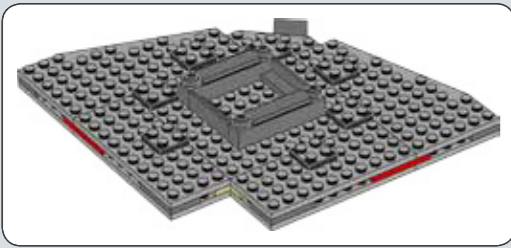

414

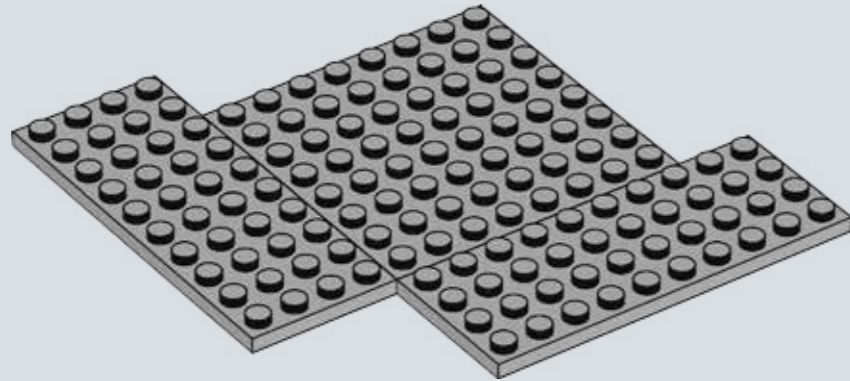

415

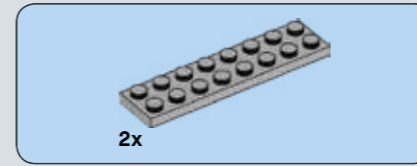
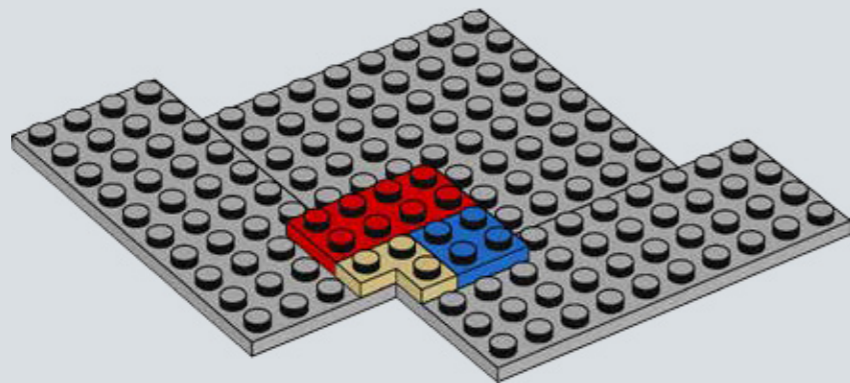

416

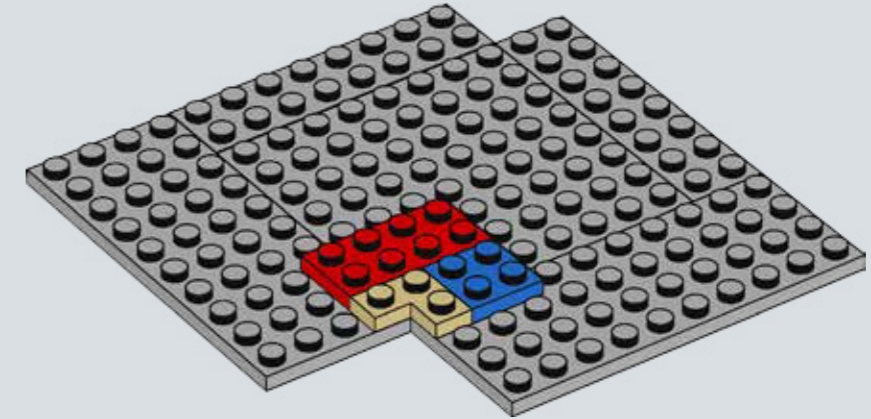

417

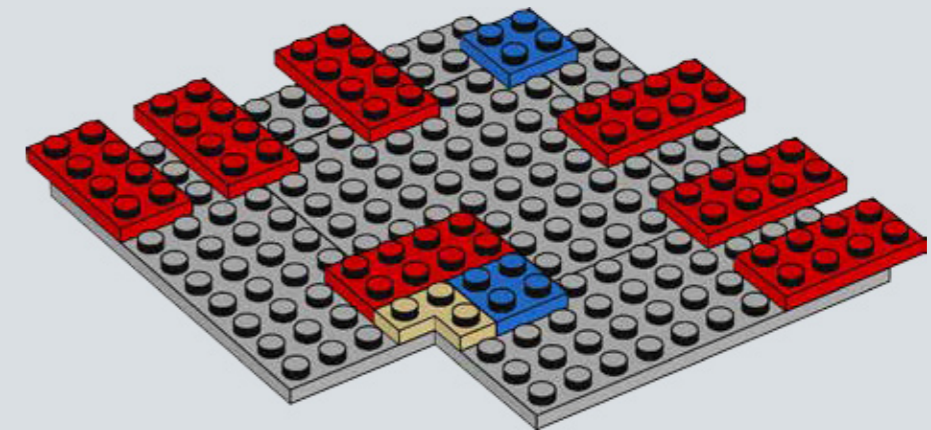

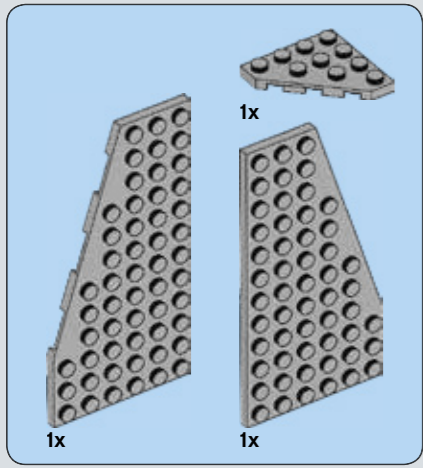

418

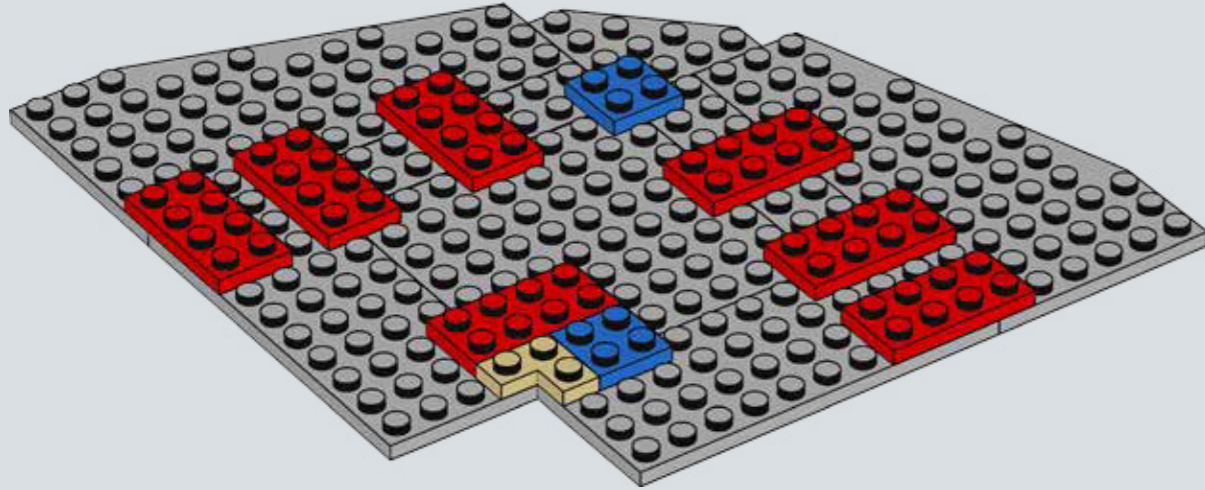

419

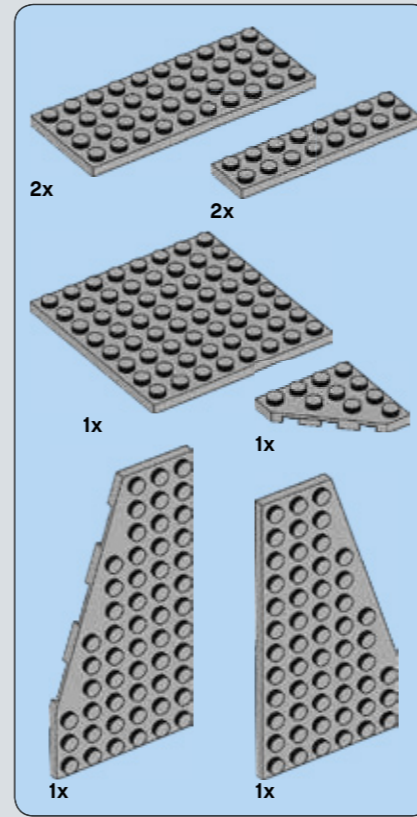
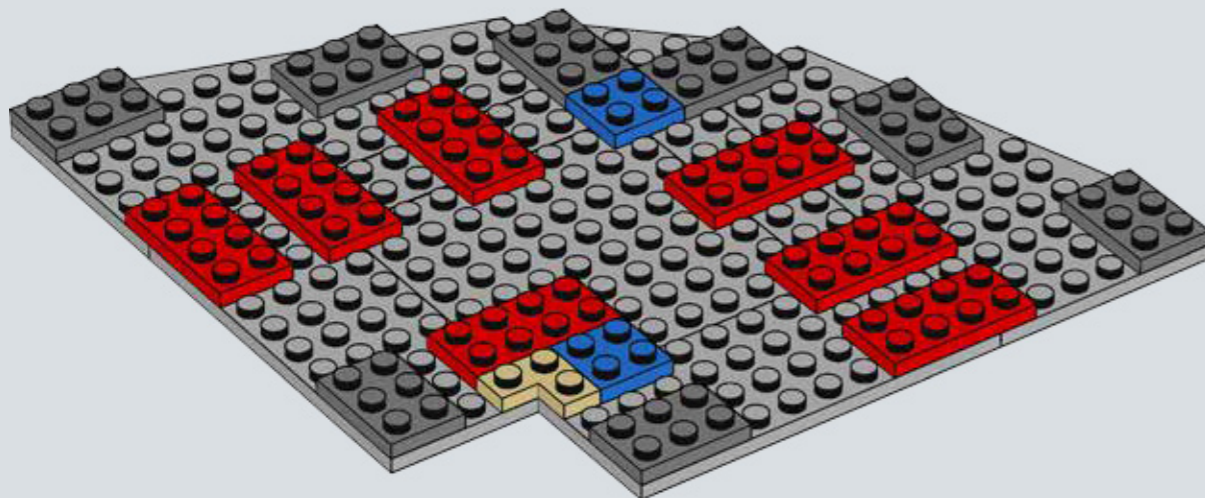

420

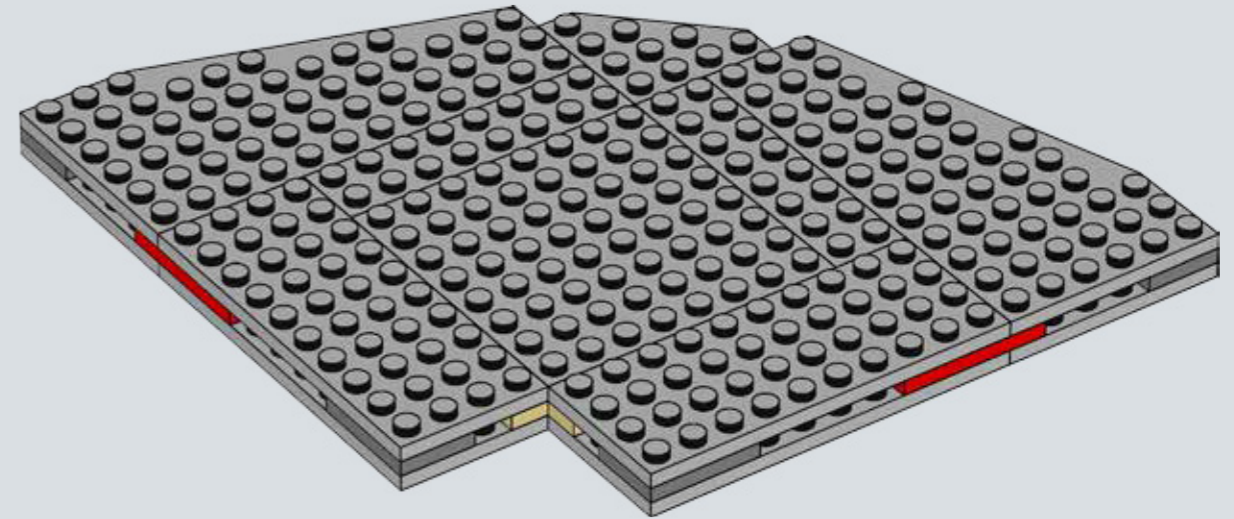

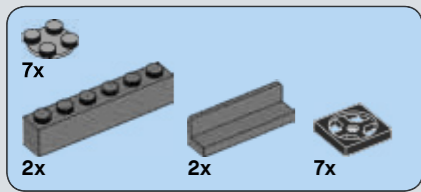

421

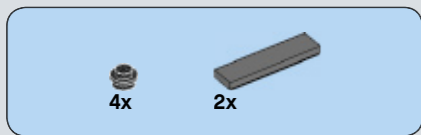
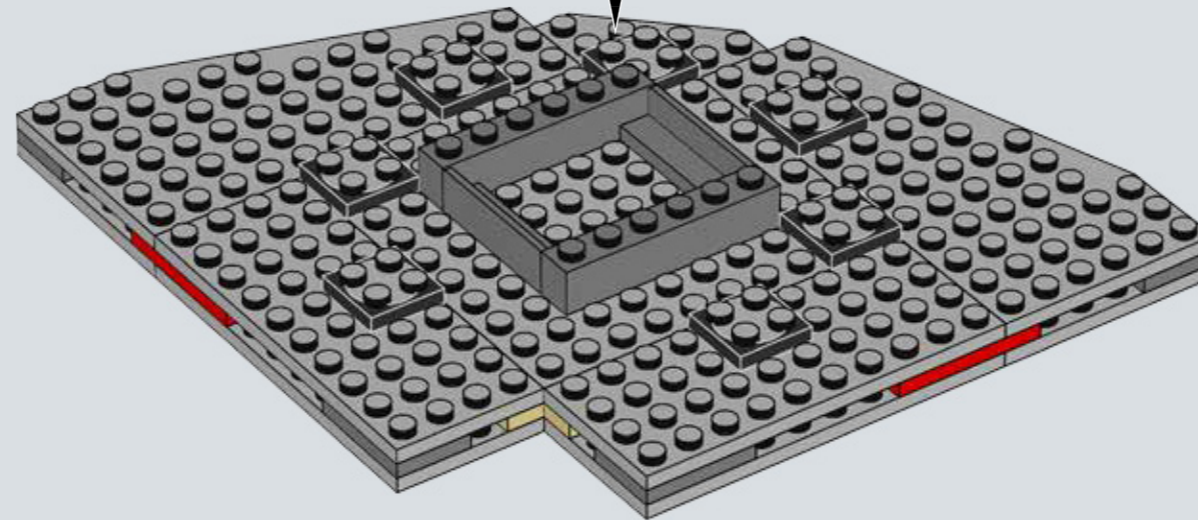
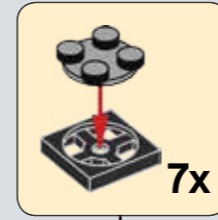

422

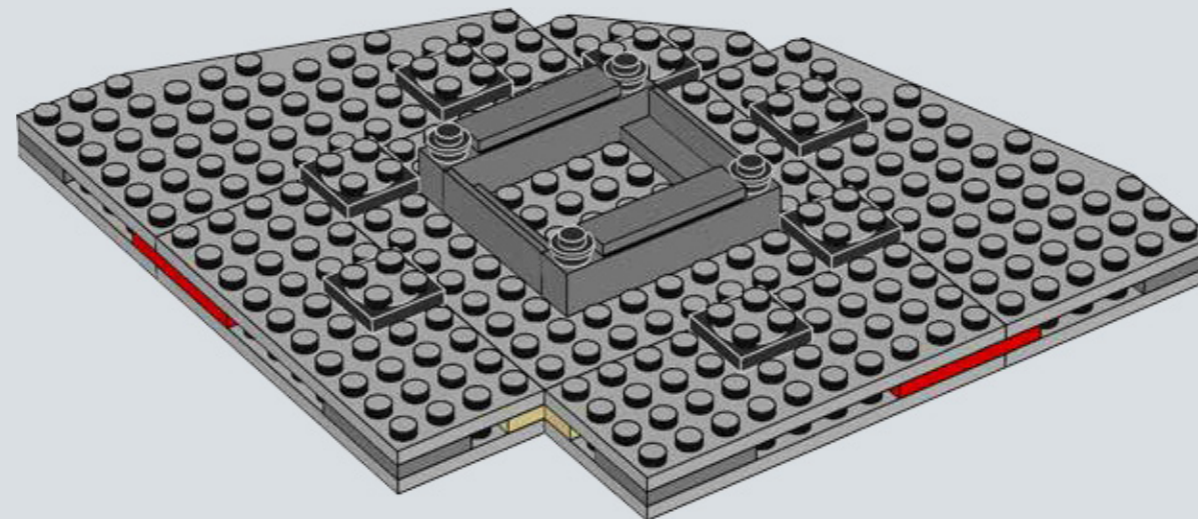

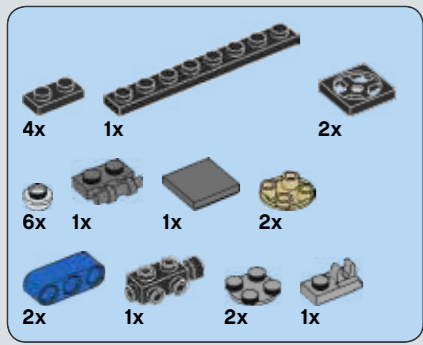

# 423

- 1
- 2
- 3

- 4
- 5
- 6
- 7

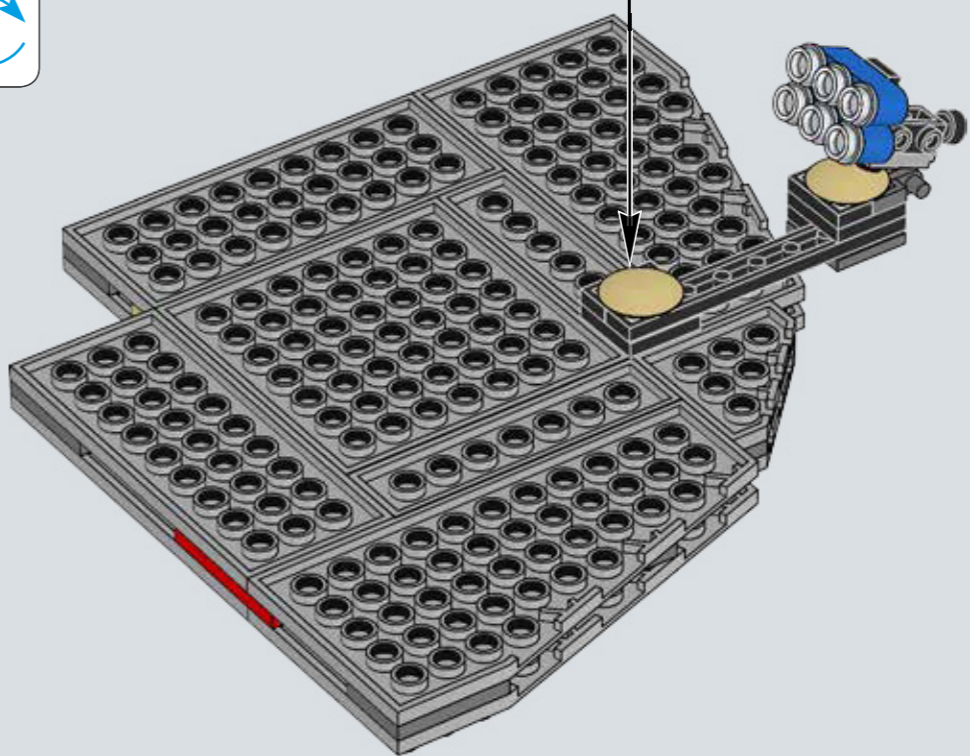
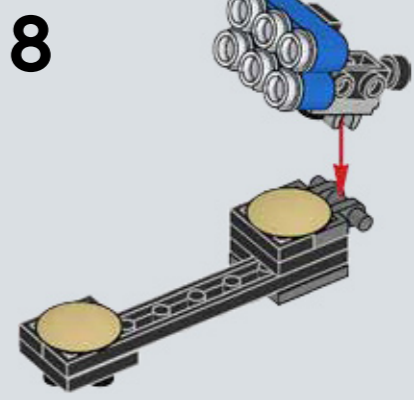
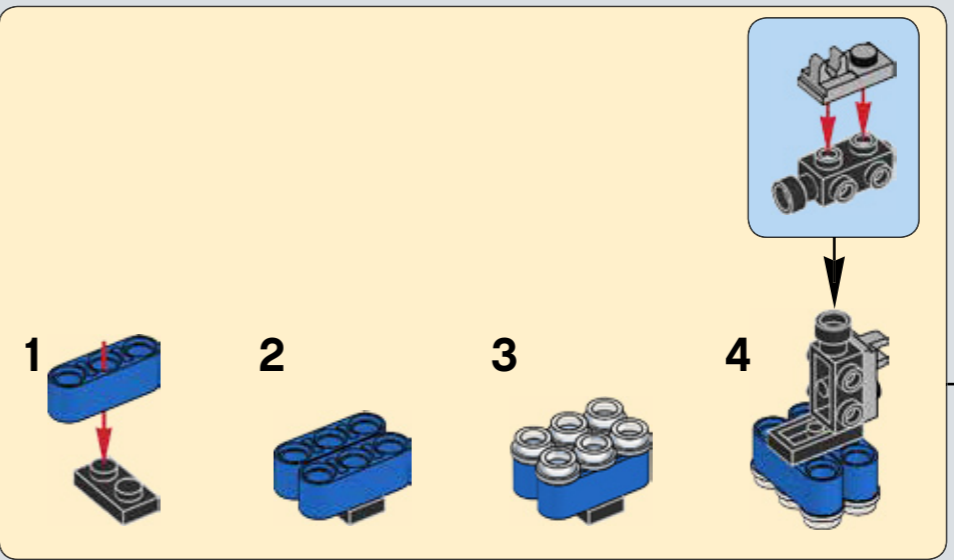

424

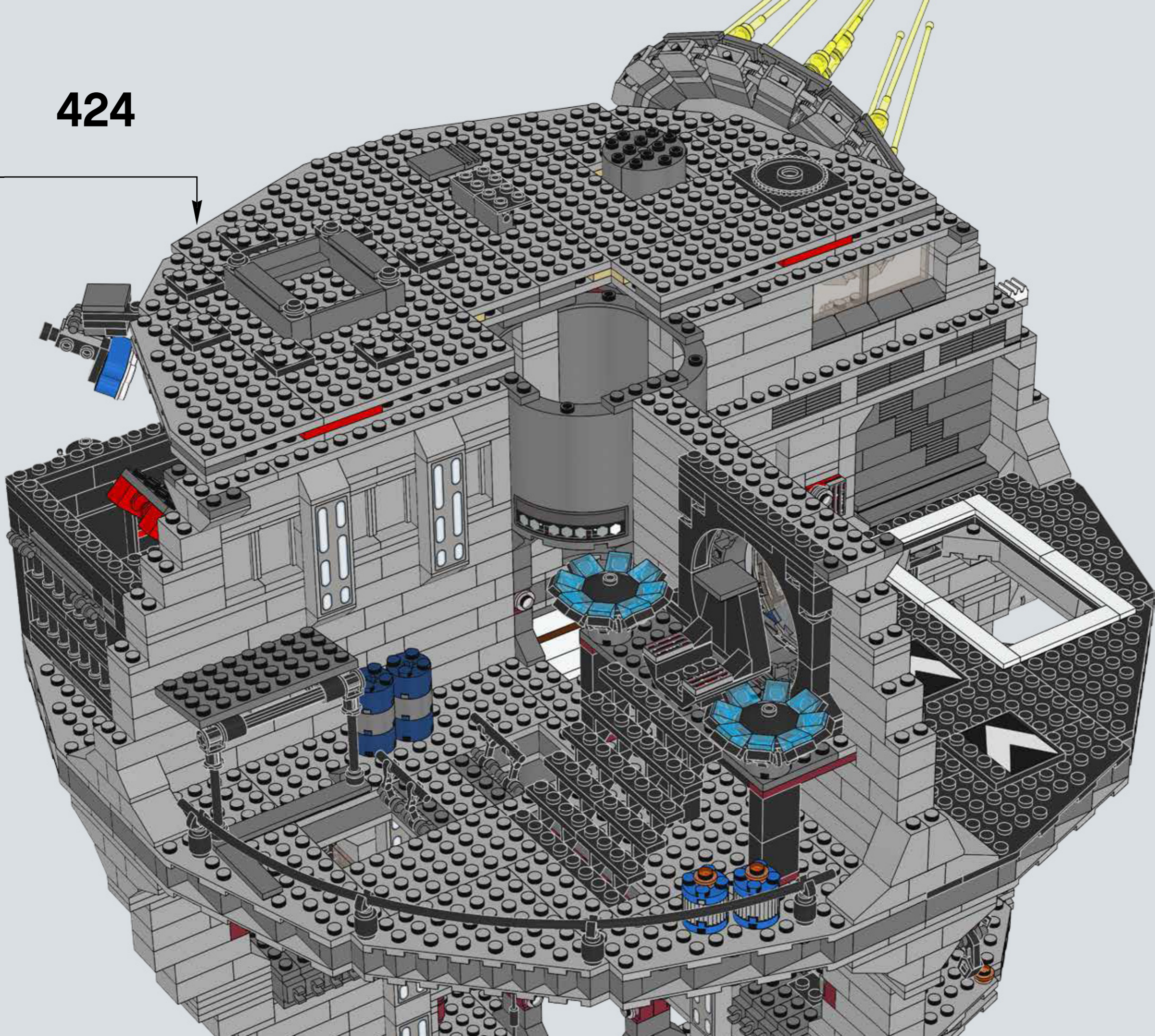

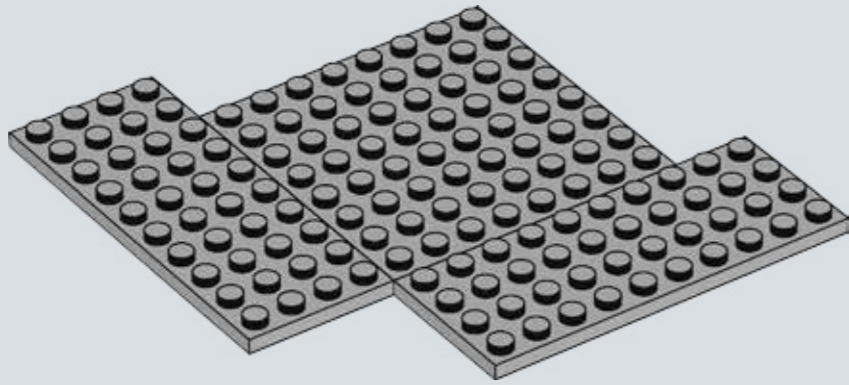
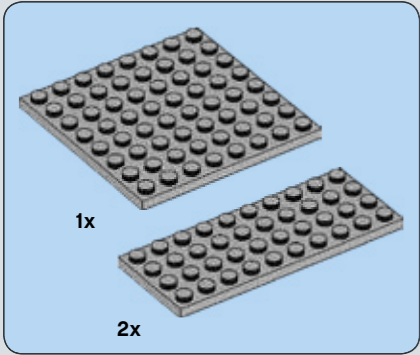
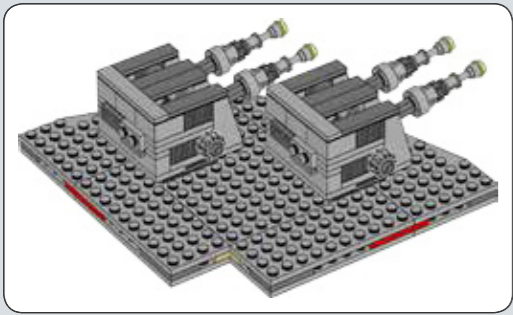

425

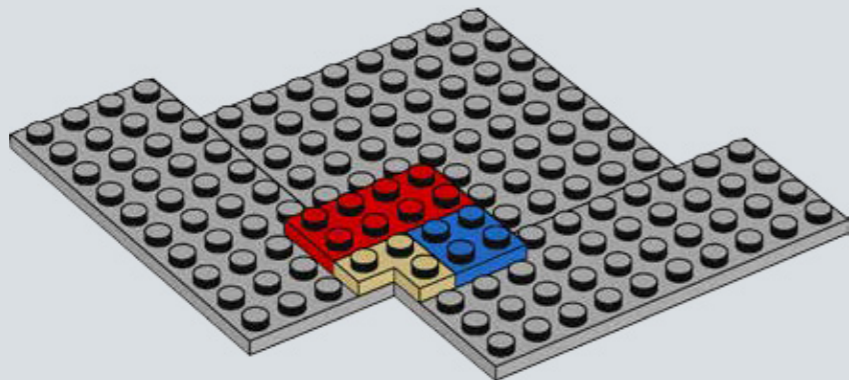
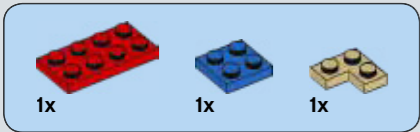

426

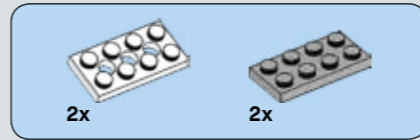

427

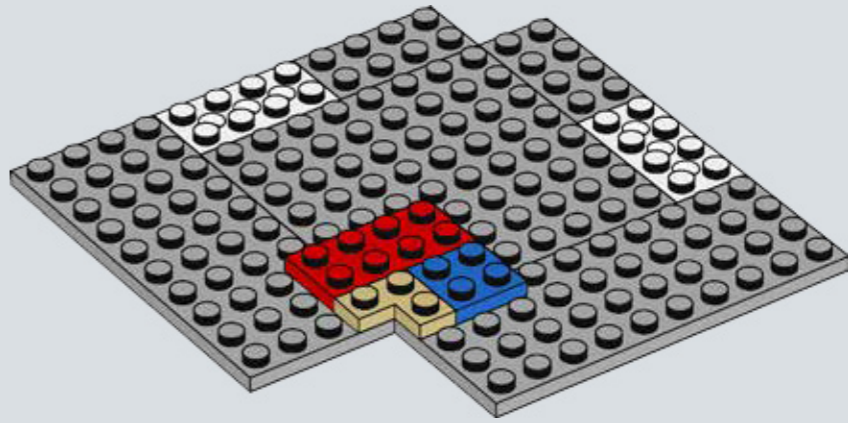

428

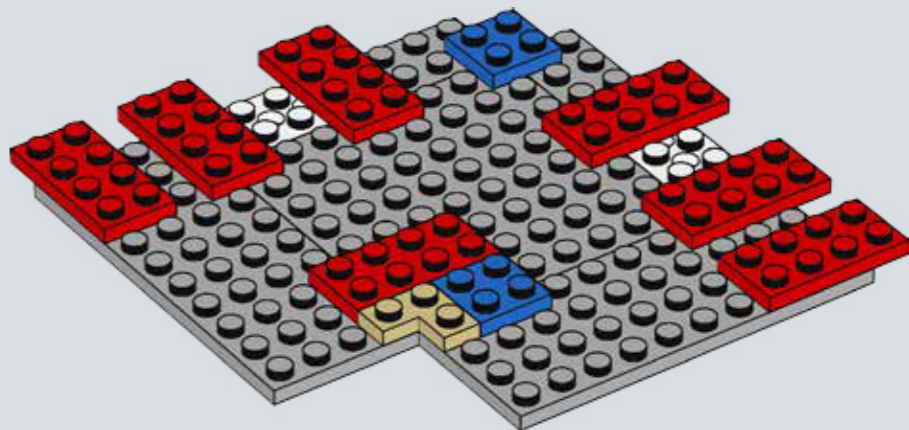

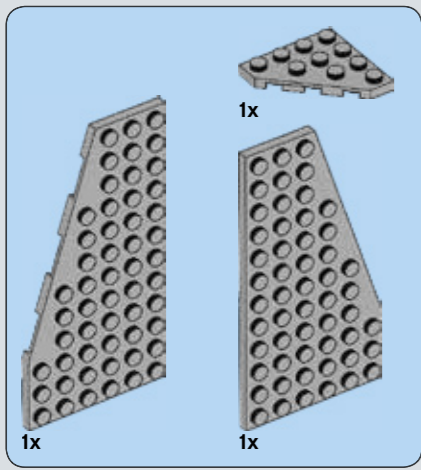

429

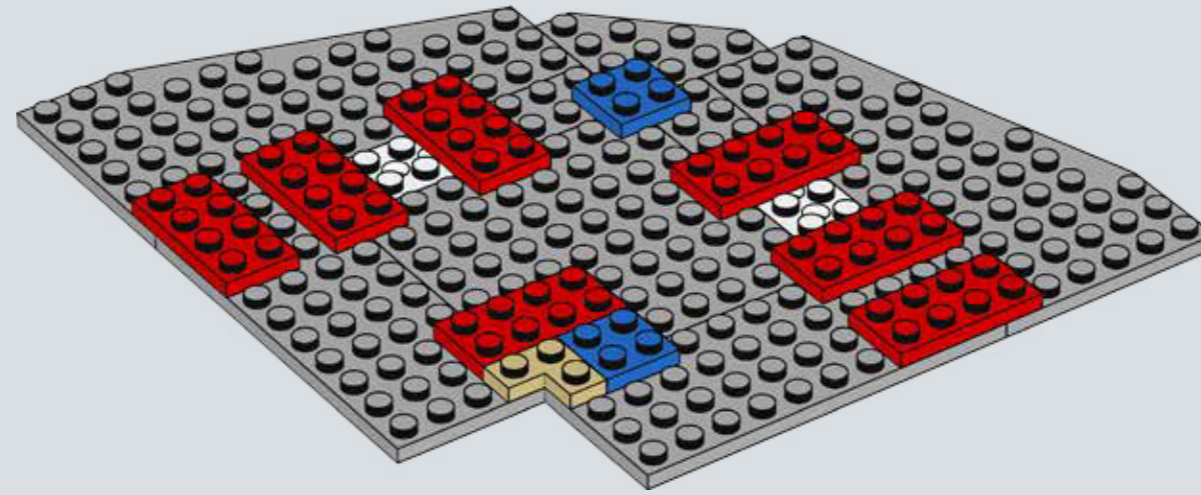

430

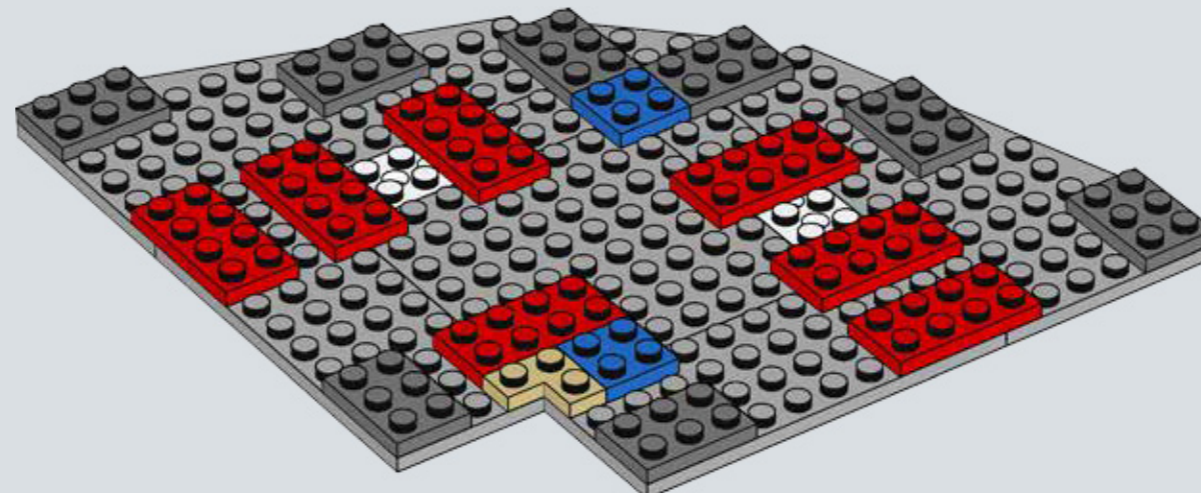

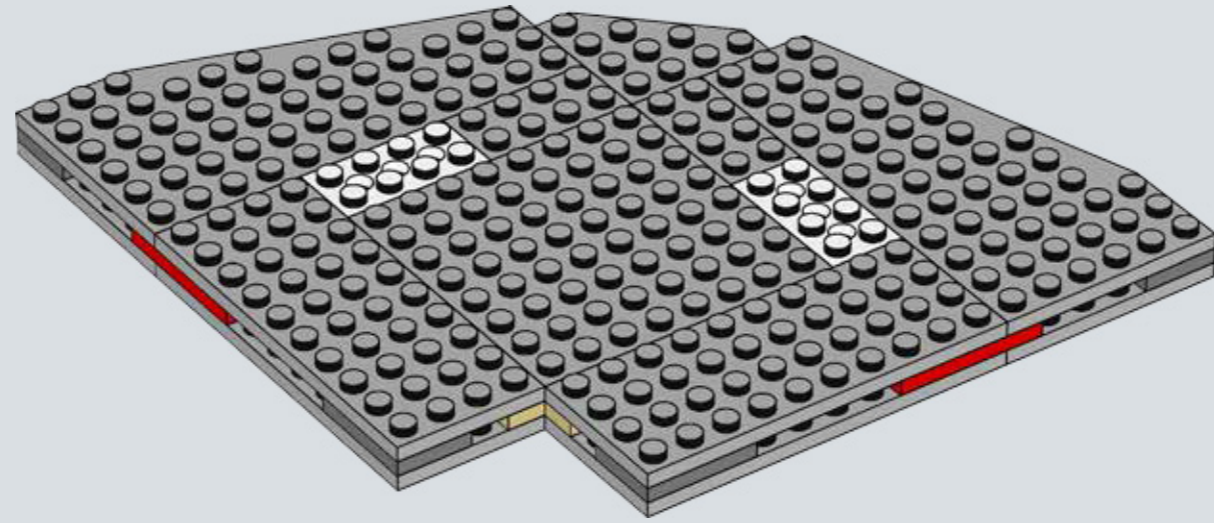
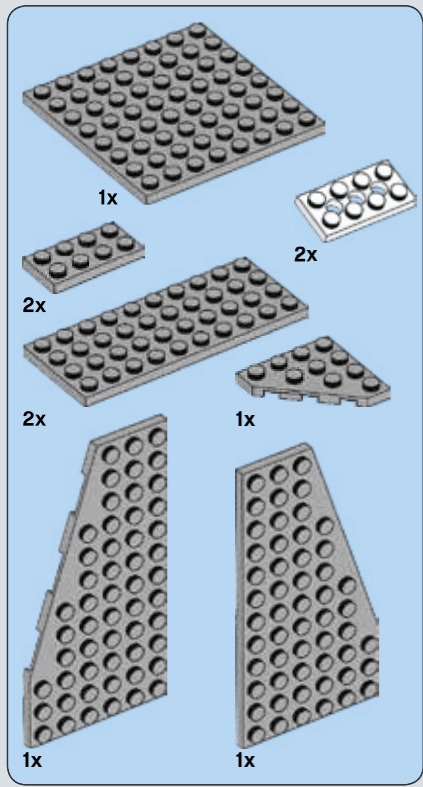

431

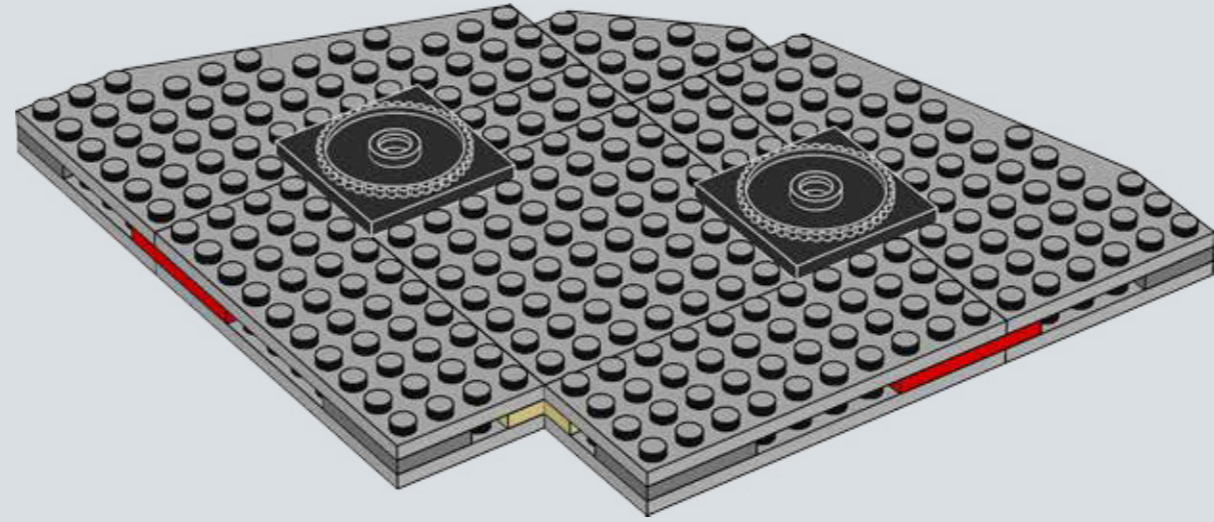
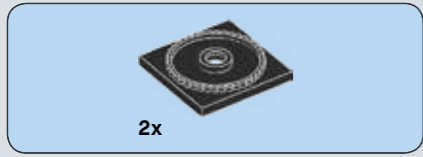

432





2x

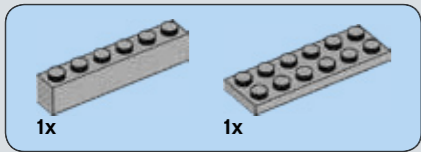

1x

1x

# 433

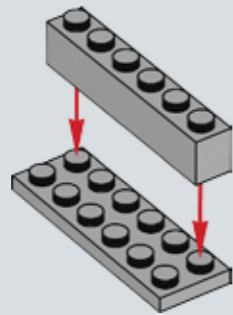

1x

# 434

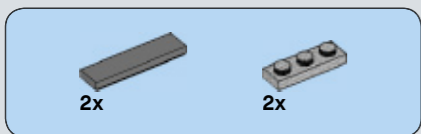
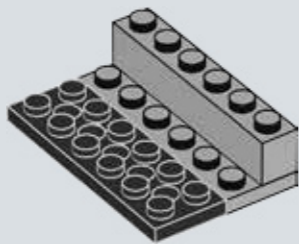

2x

2x

# 435

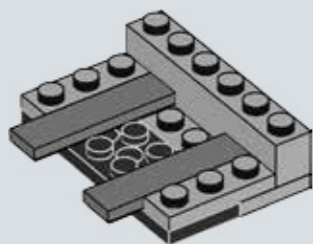

1x

# 436

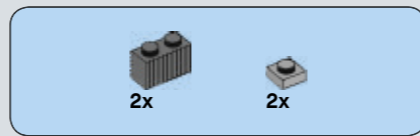
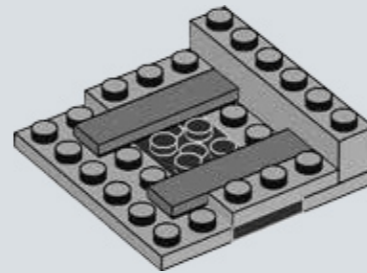

2x

2x

# 437

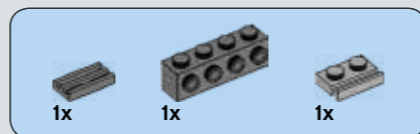
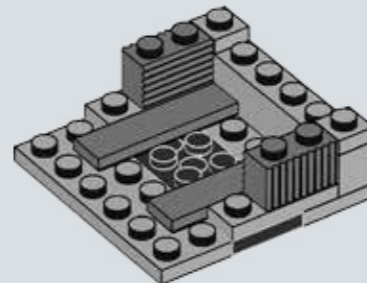

1x

1x

1x

# 438

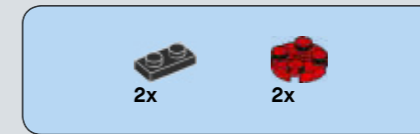
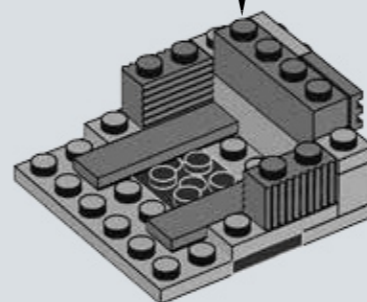
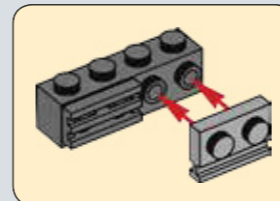

2x

2x

# 439

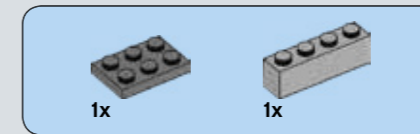
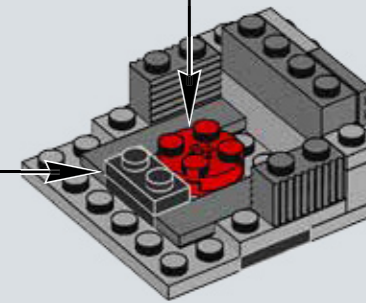
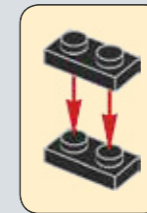

1x

1x

# 440

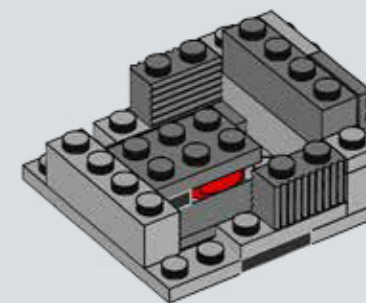

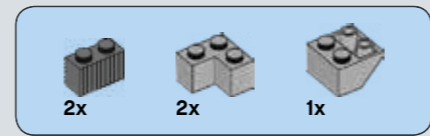
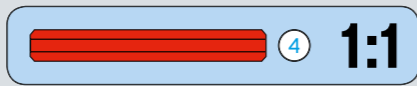
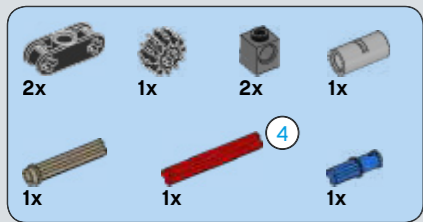

# 443

# 441

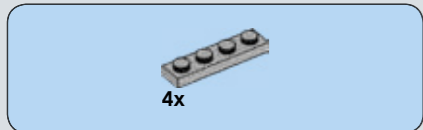
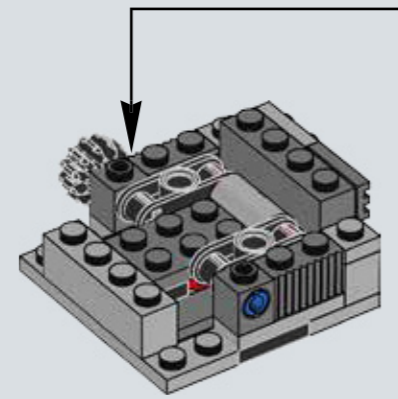
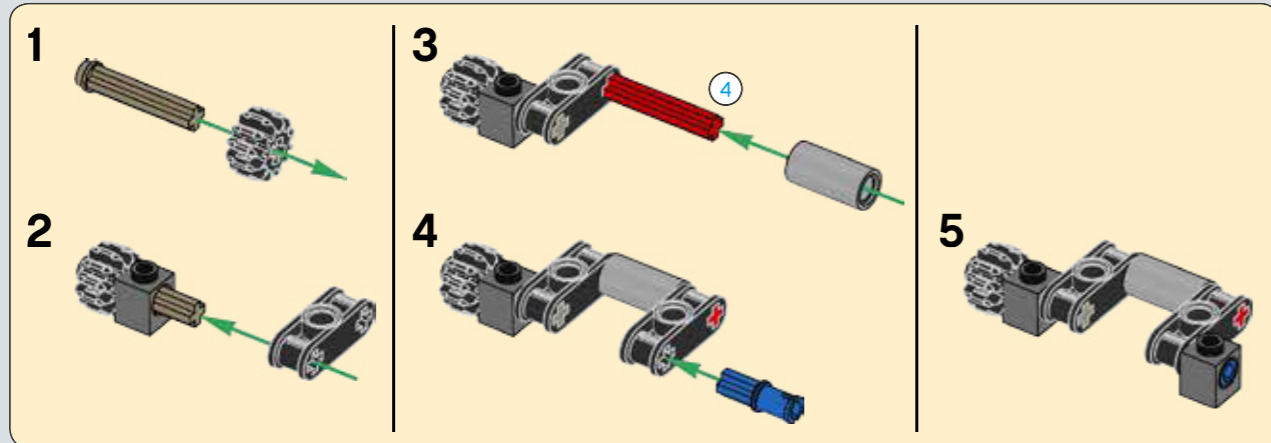

# 442

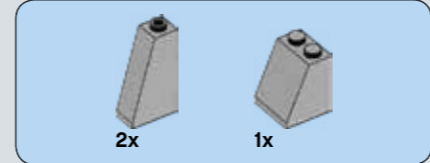
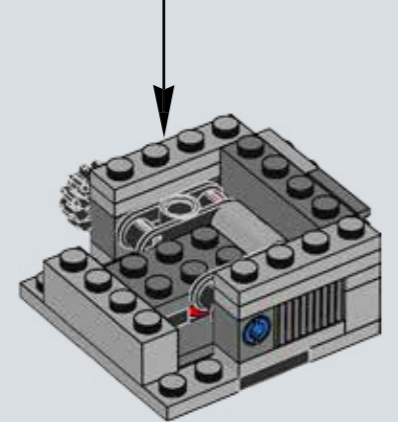
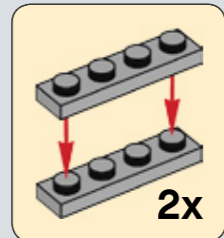

# 444

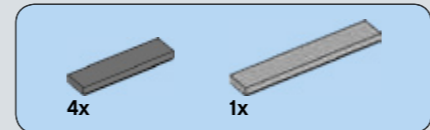
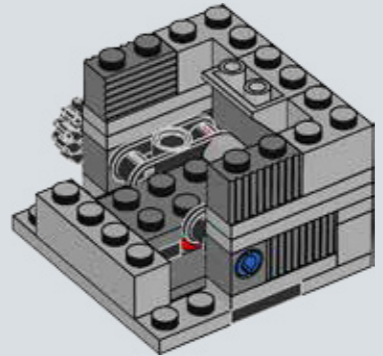

# 445

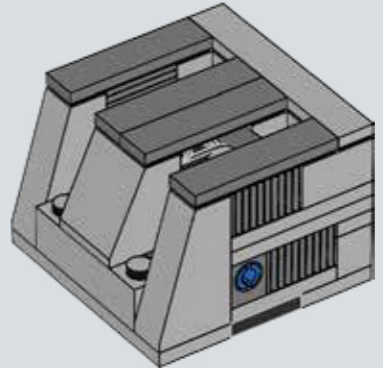
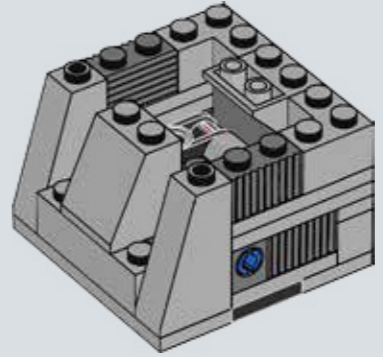



446

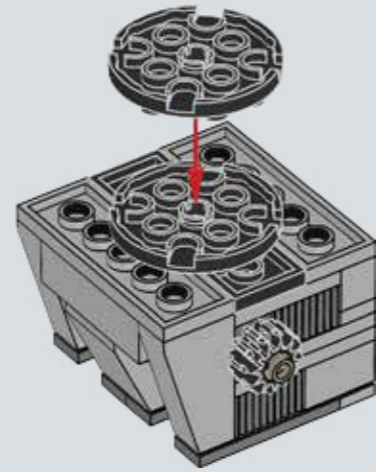

447

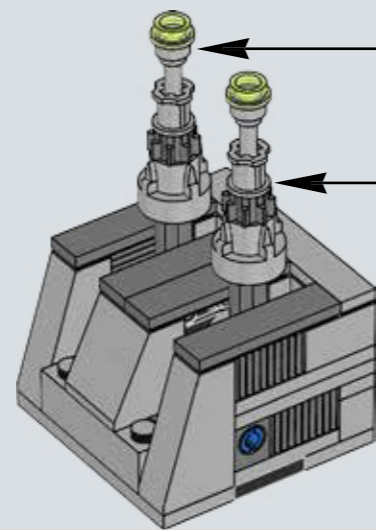
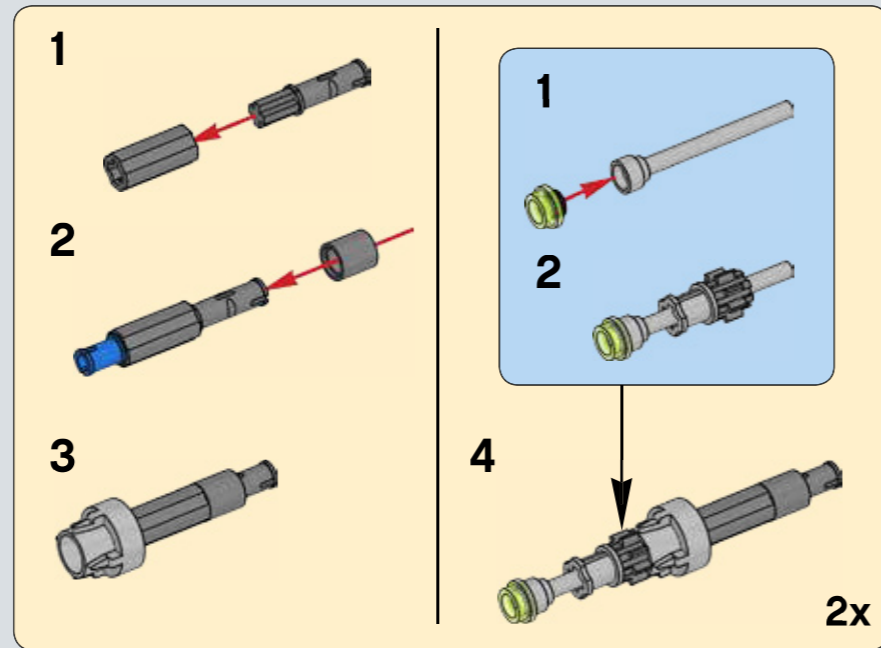
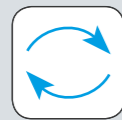

2x

448

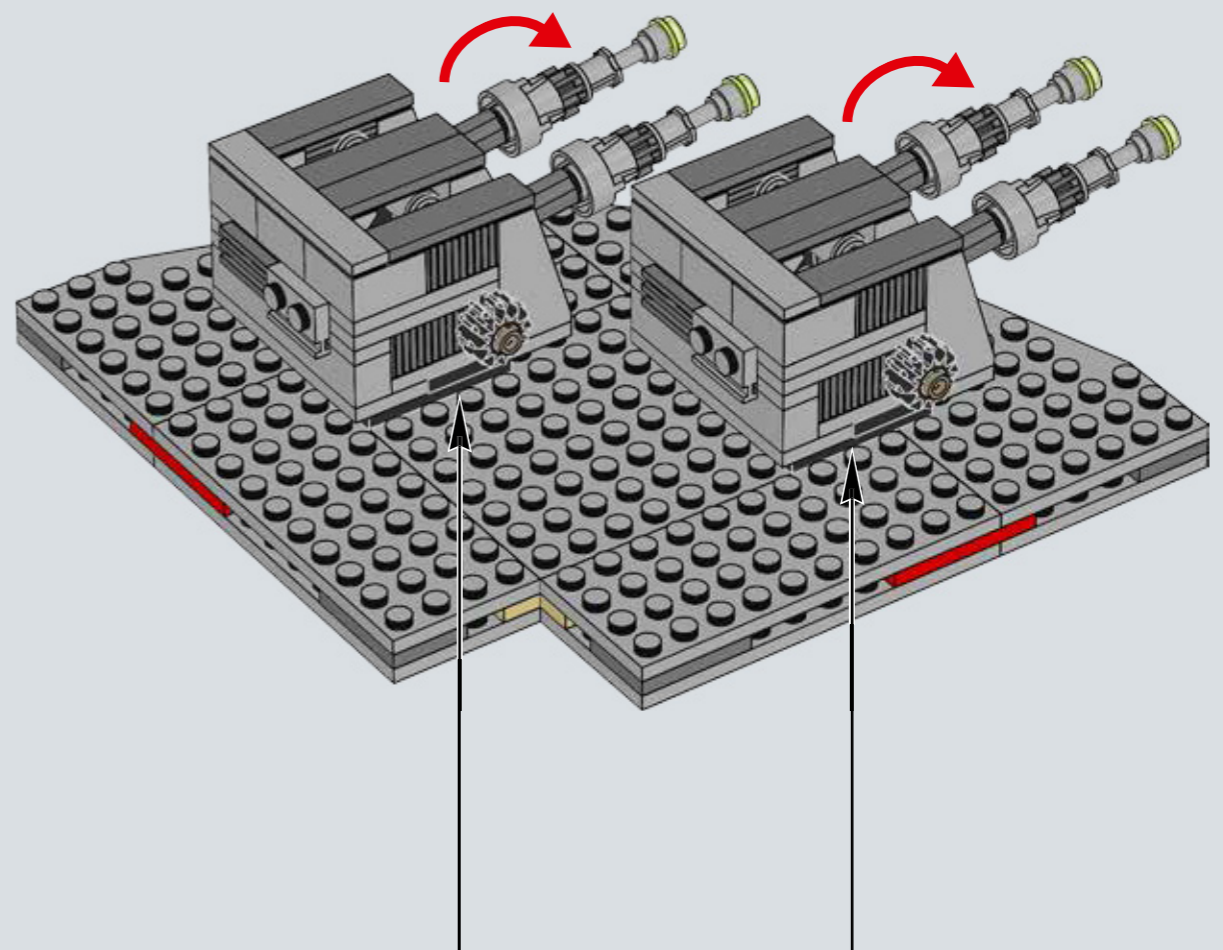

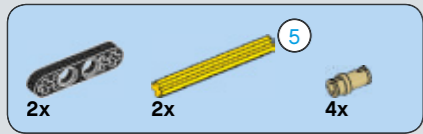

# 449

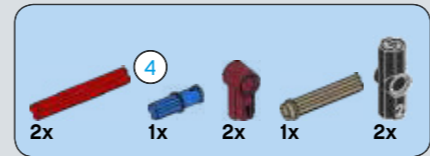
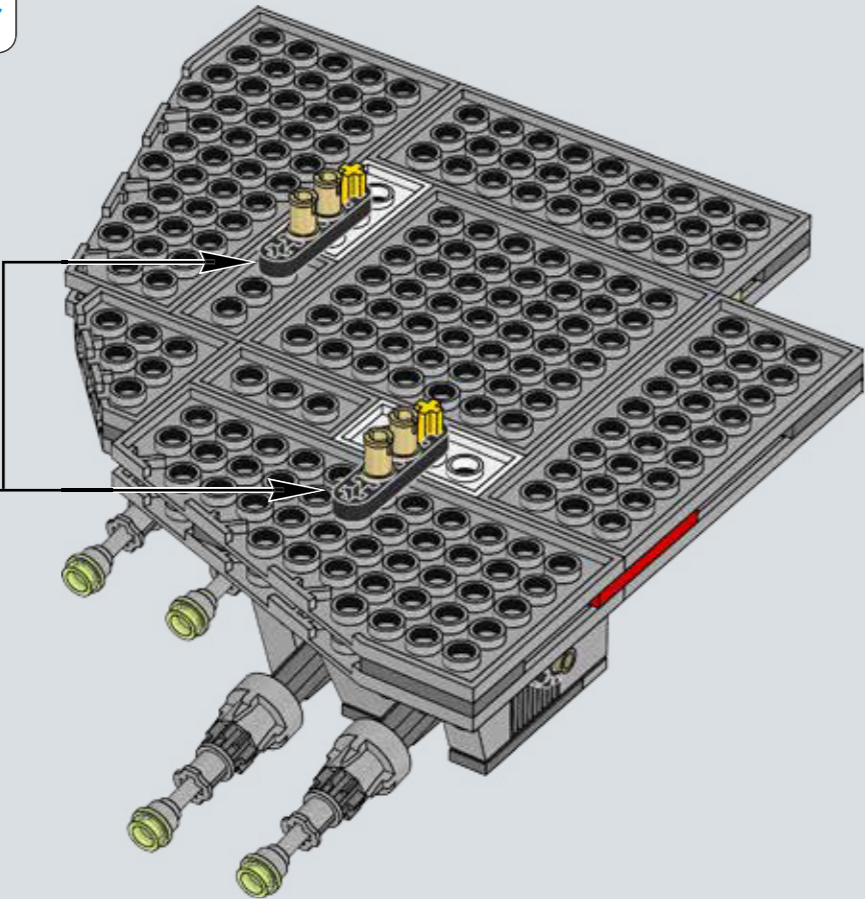
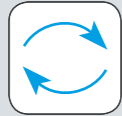

# 450

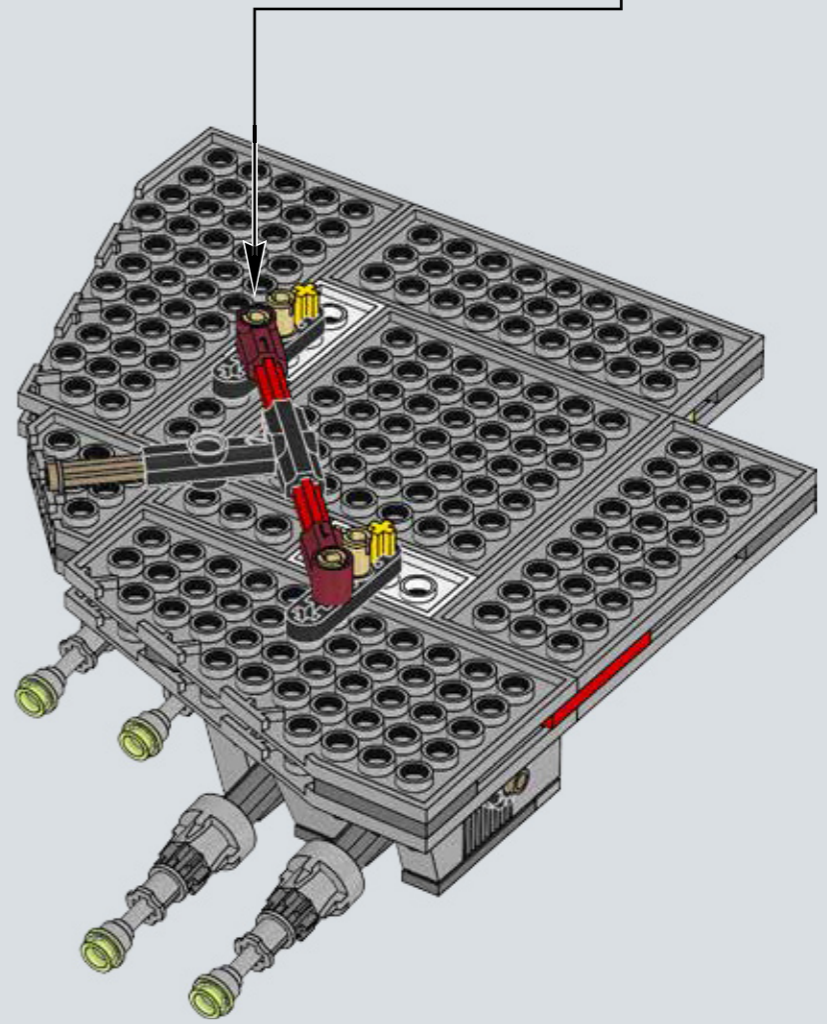
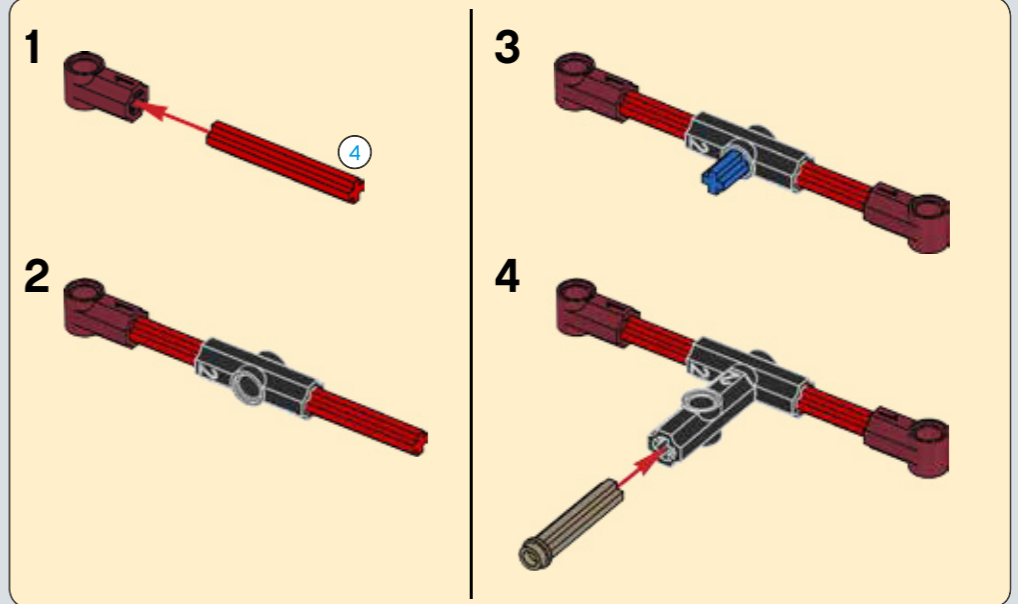

451

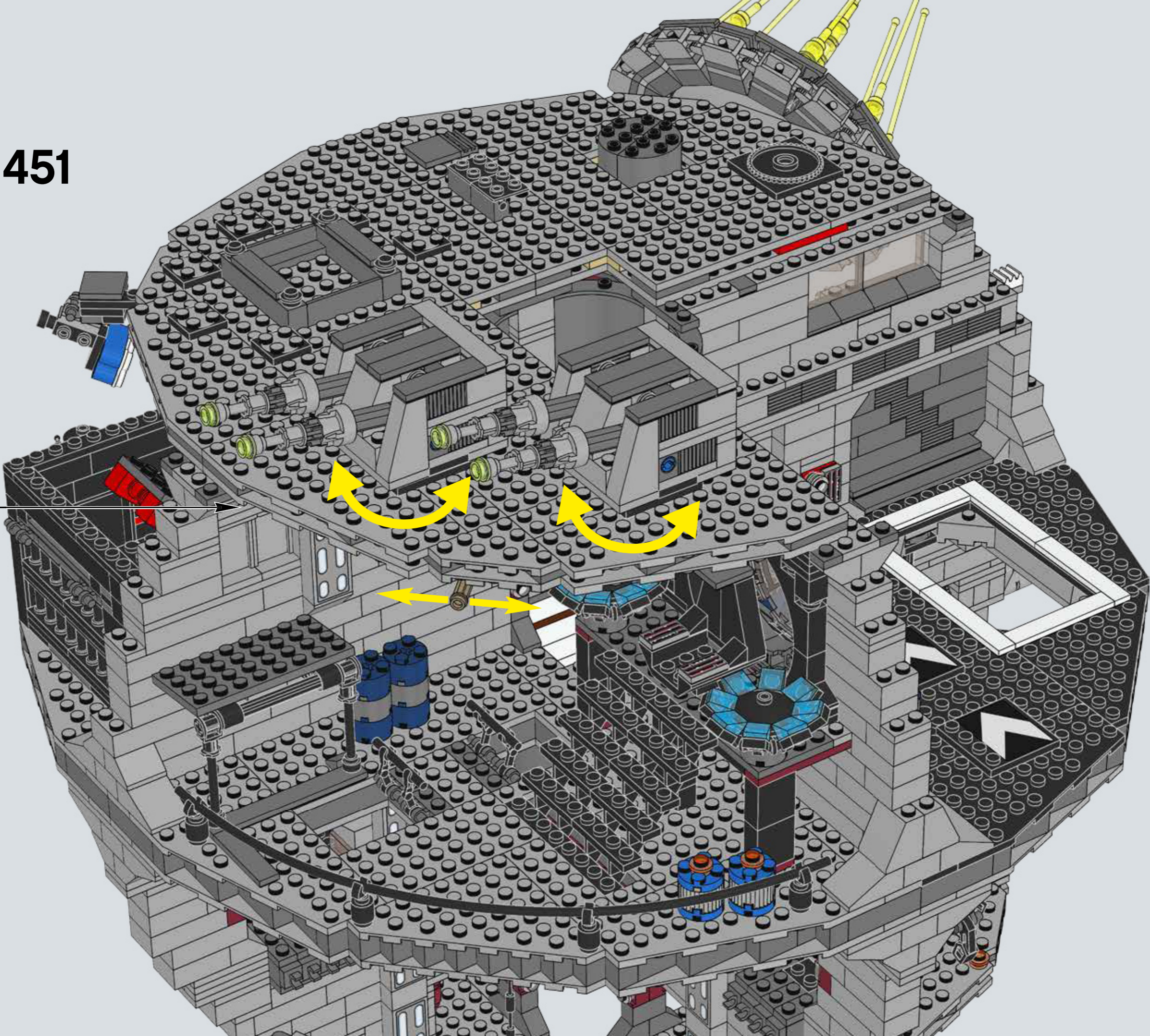

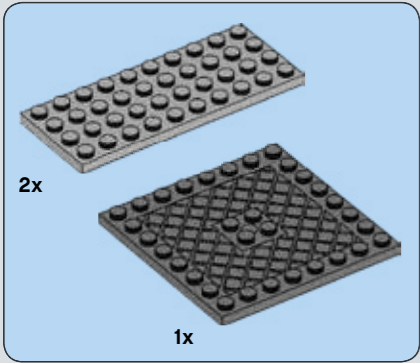
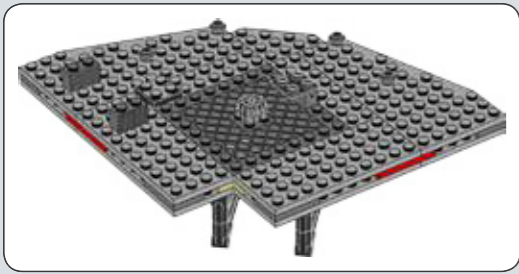

452

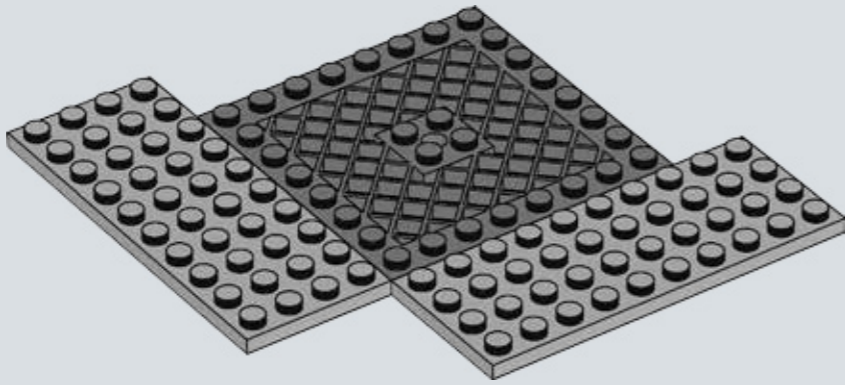

453

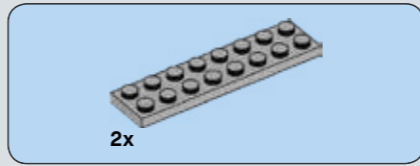
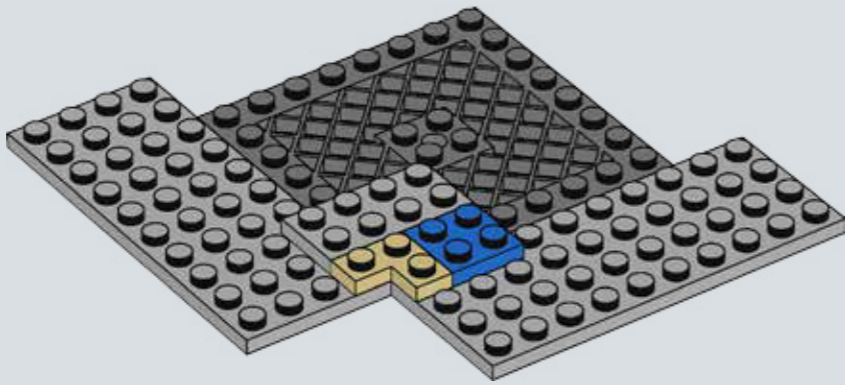

454

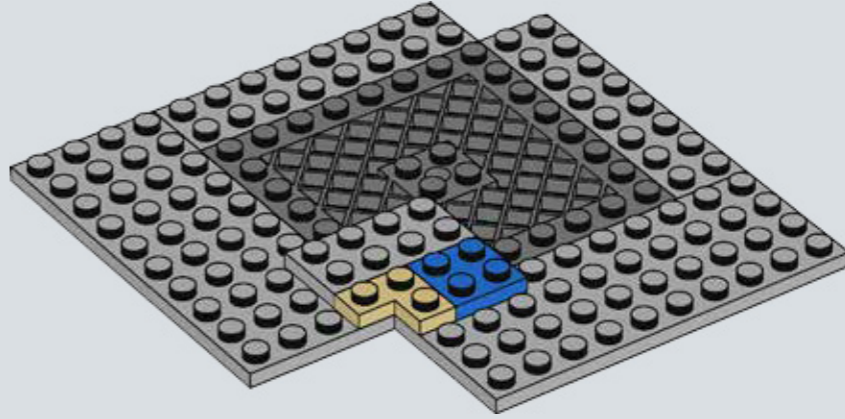

455

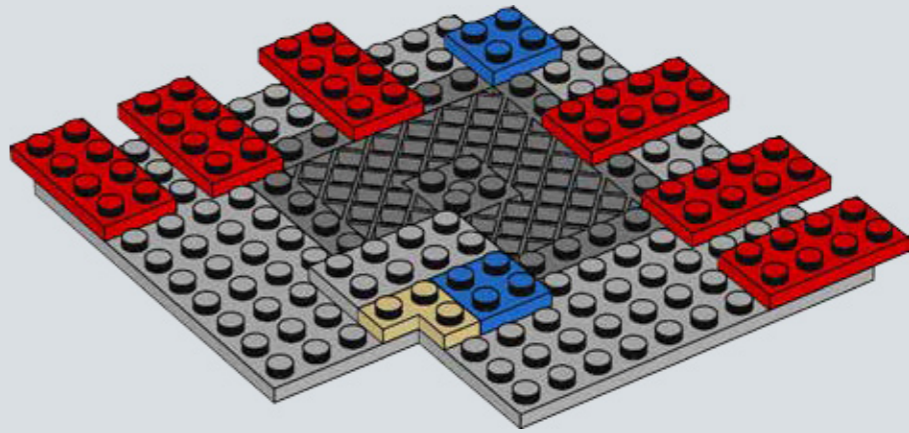

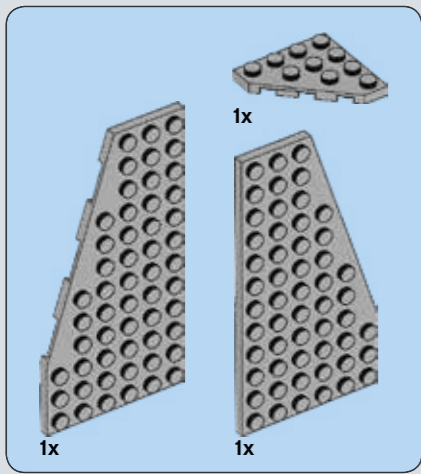

**456**

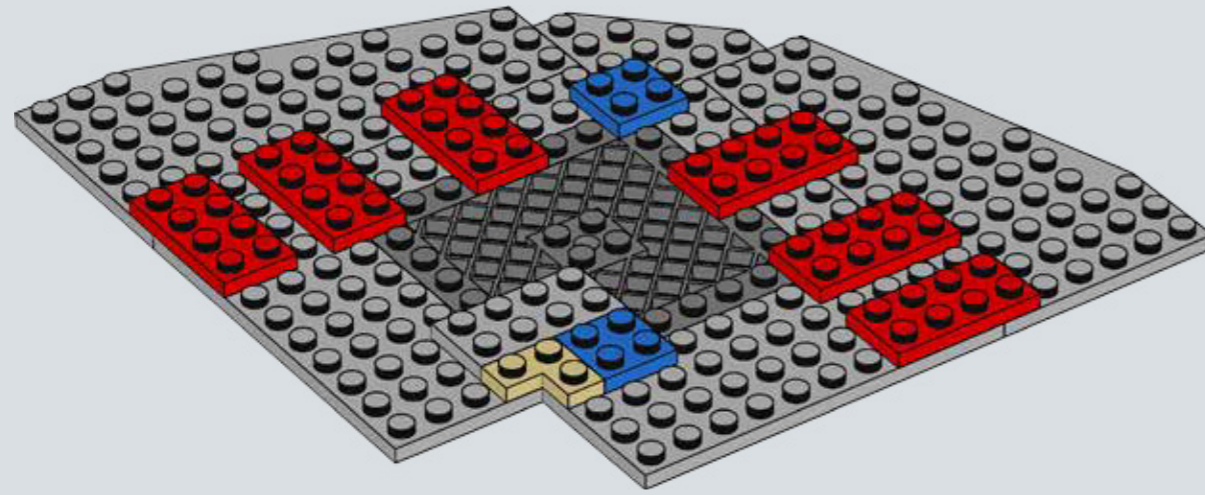

**457**

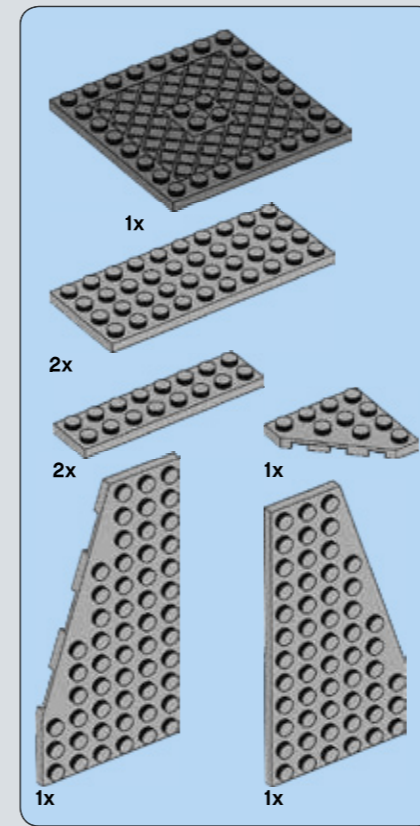
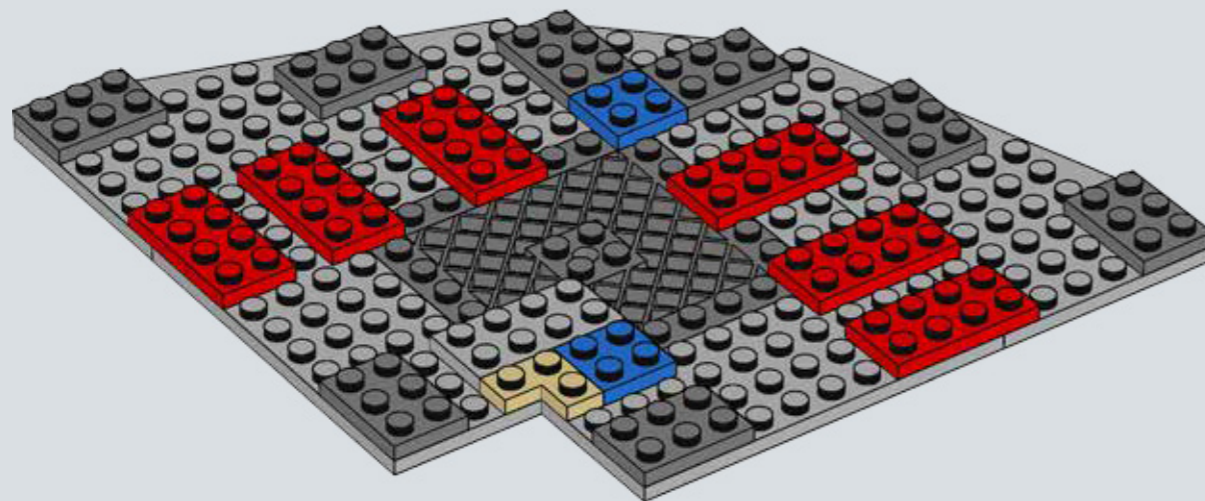

**458**

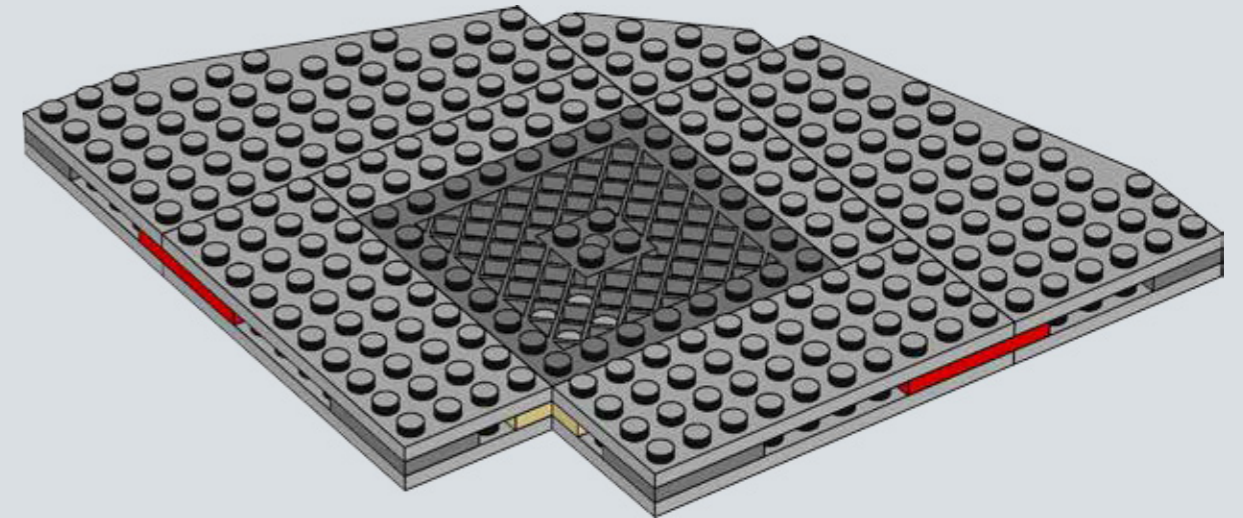

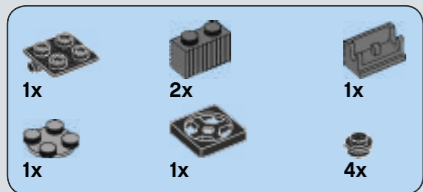

459

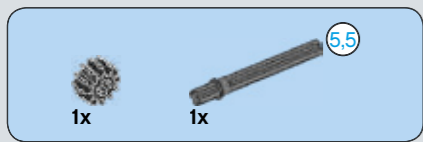
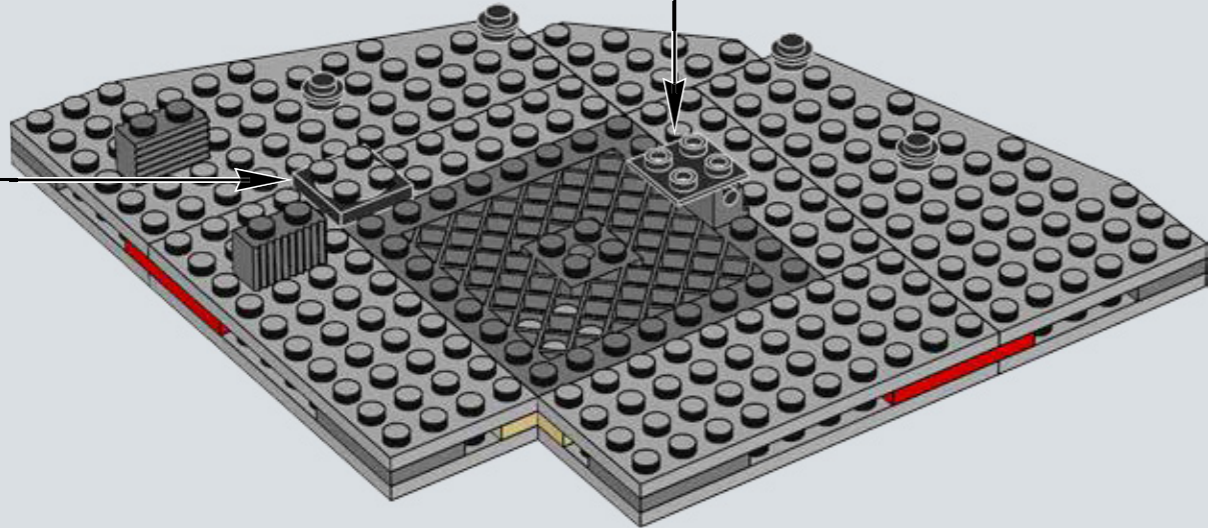
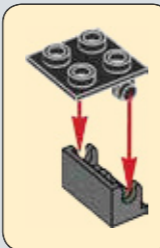
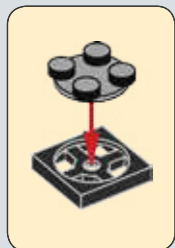

460

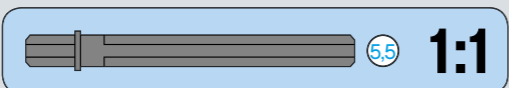
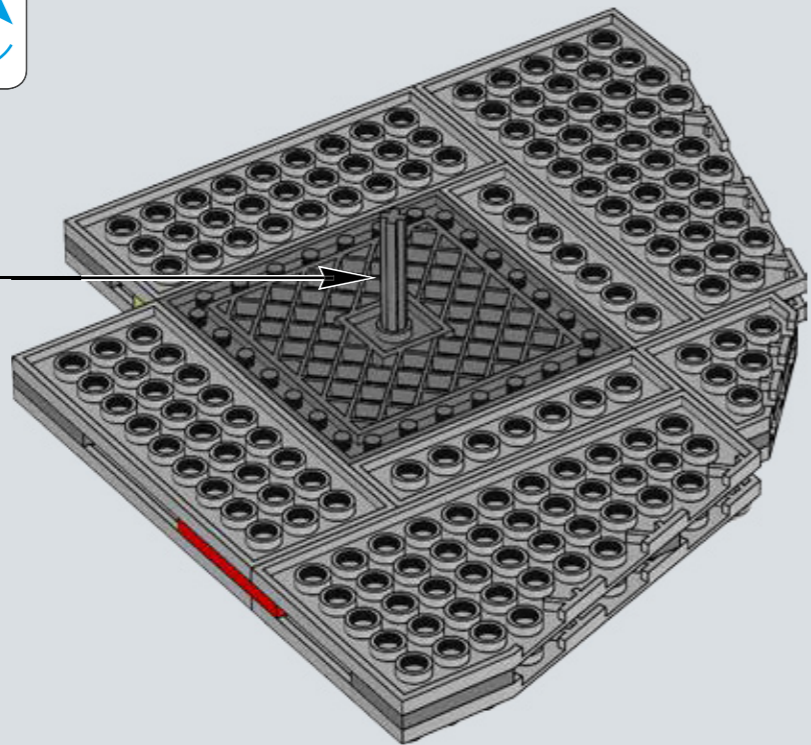
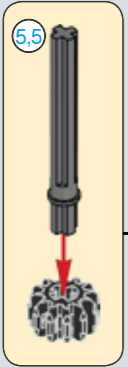
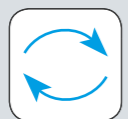

461

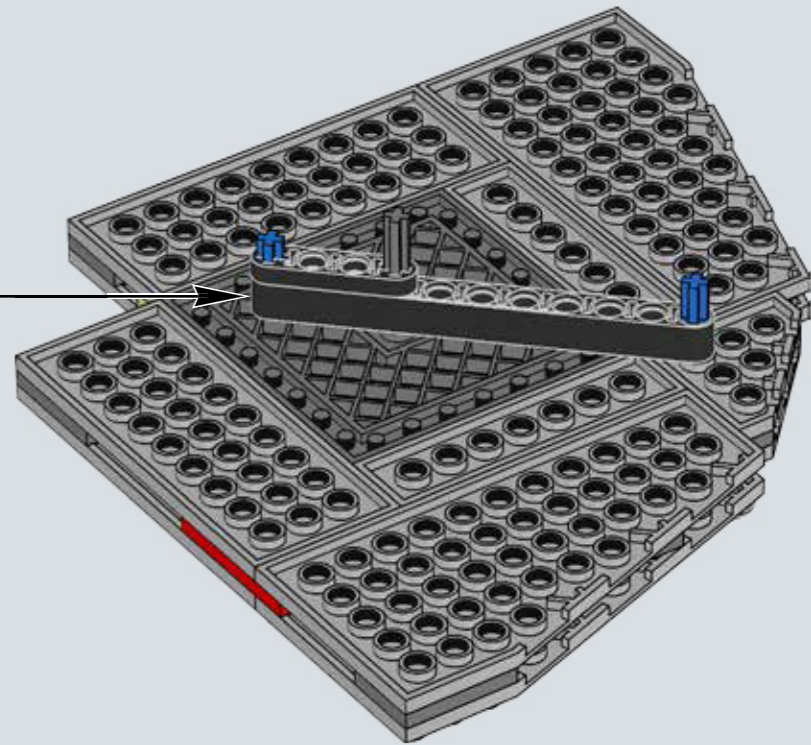
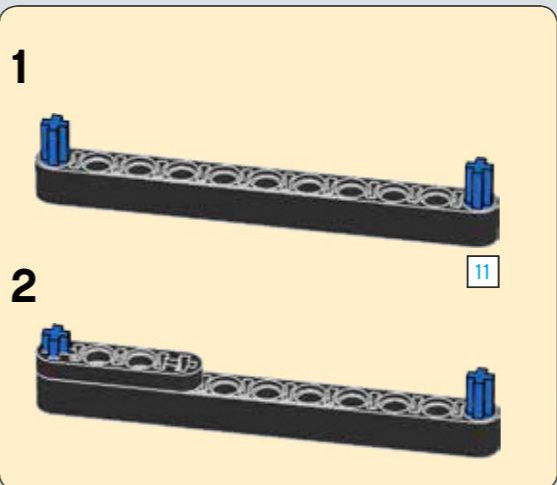

462

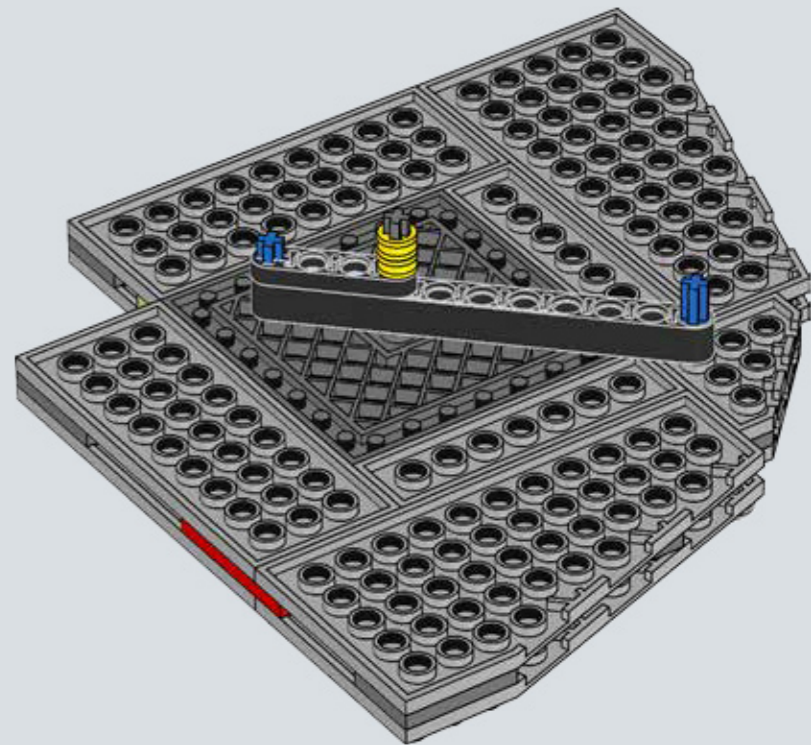
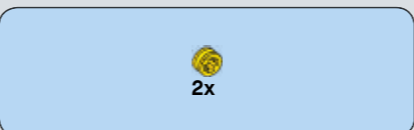



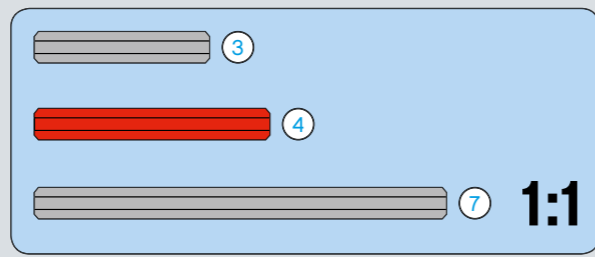
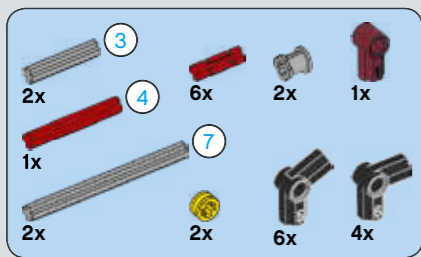

# 463

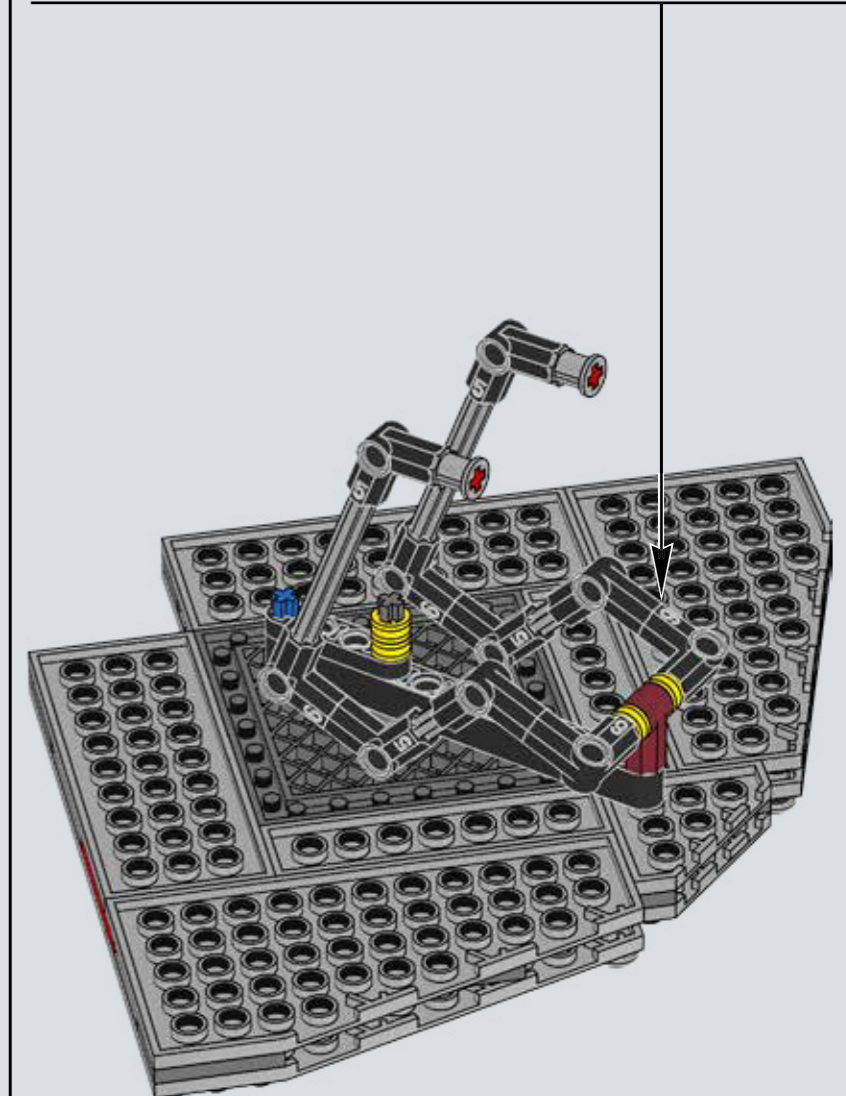
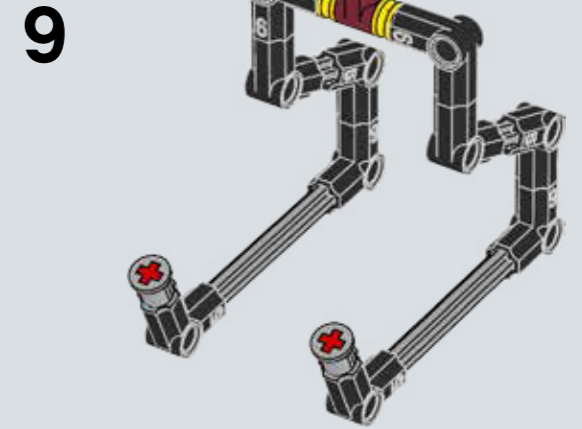
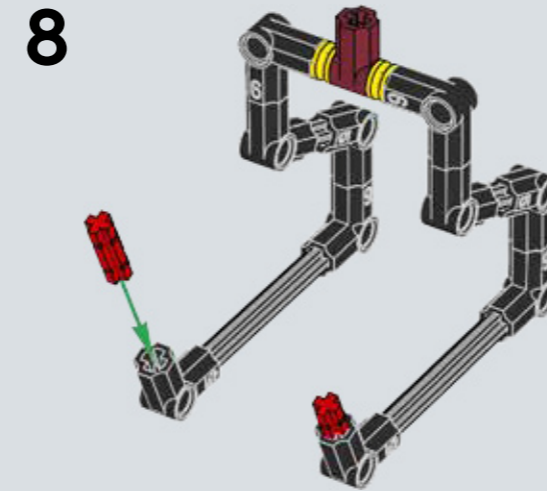
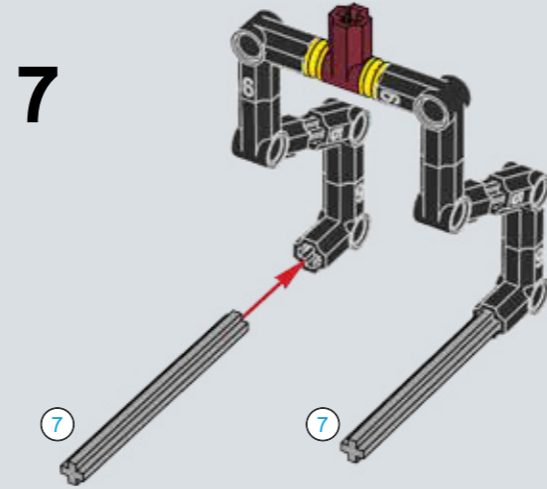
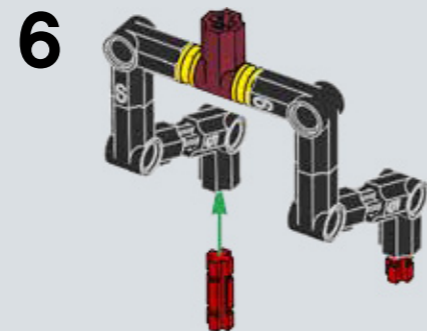
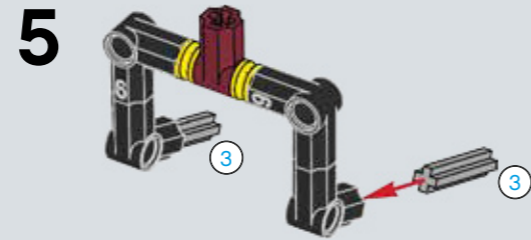
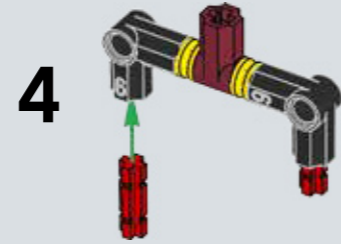
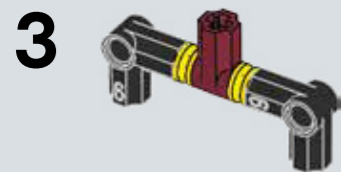
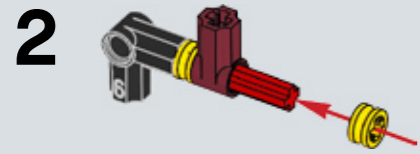

464

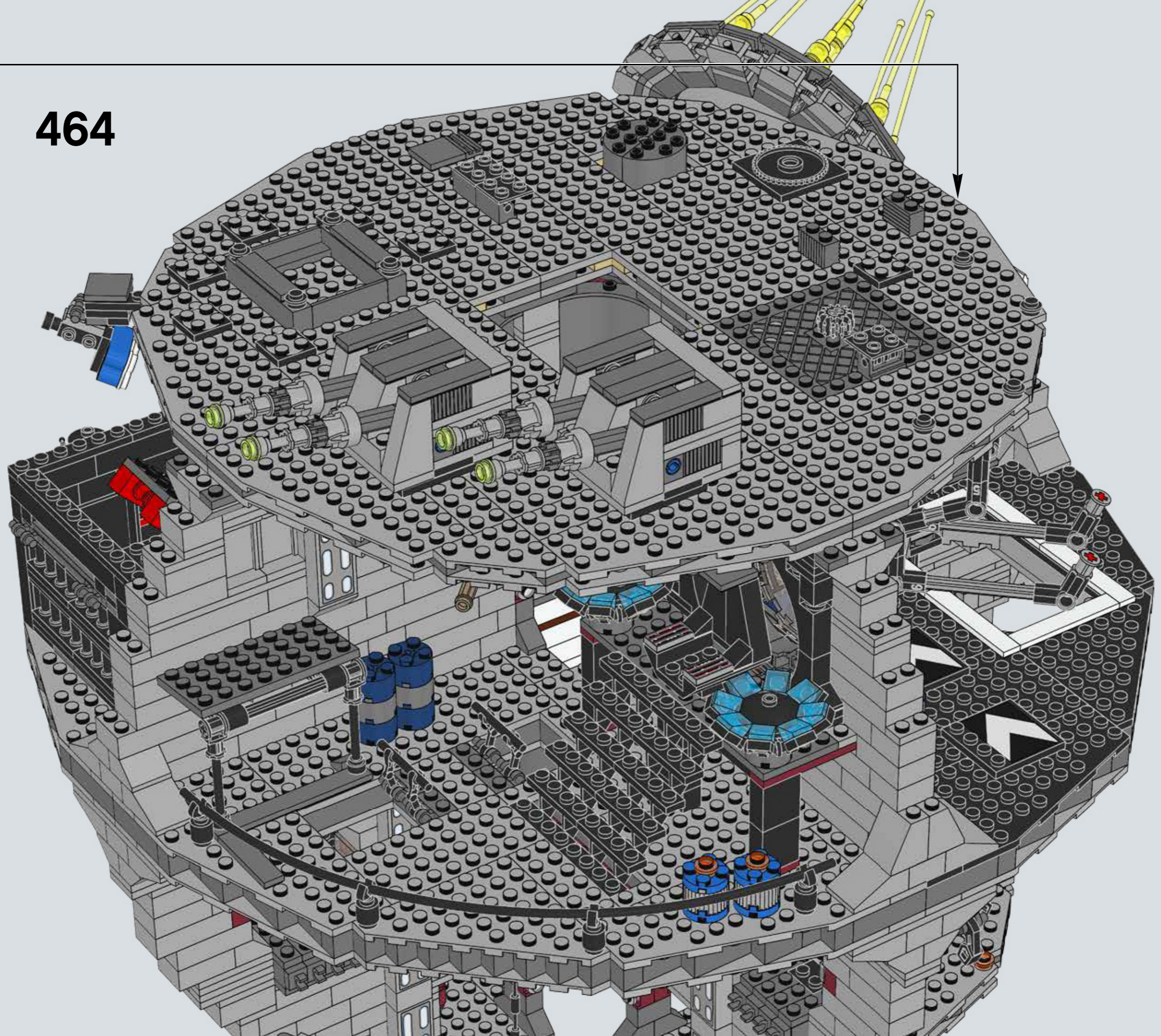

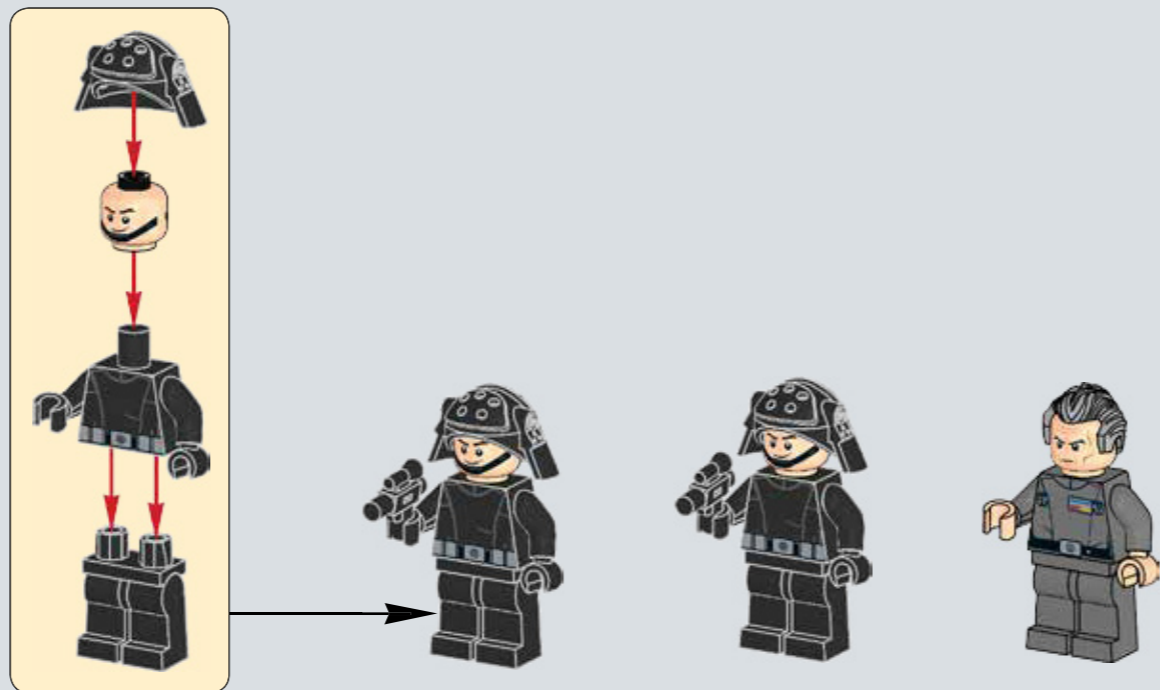
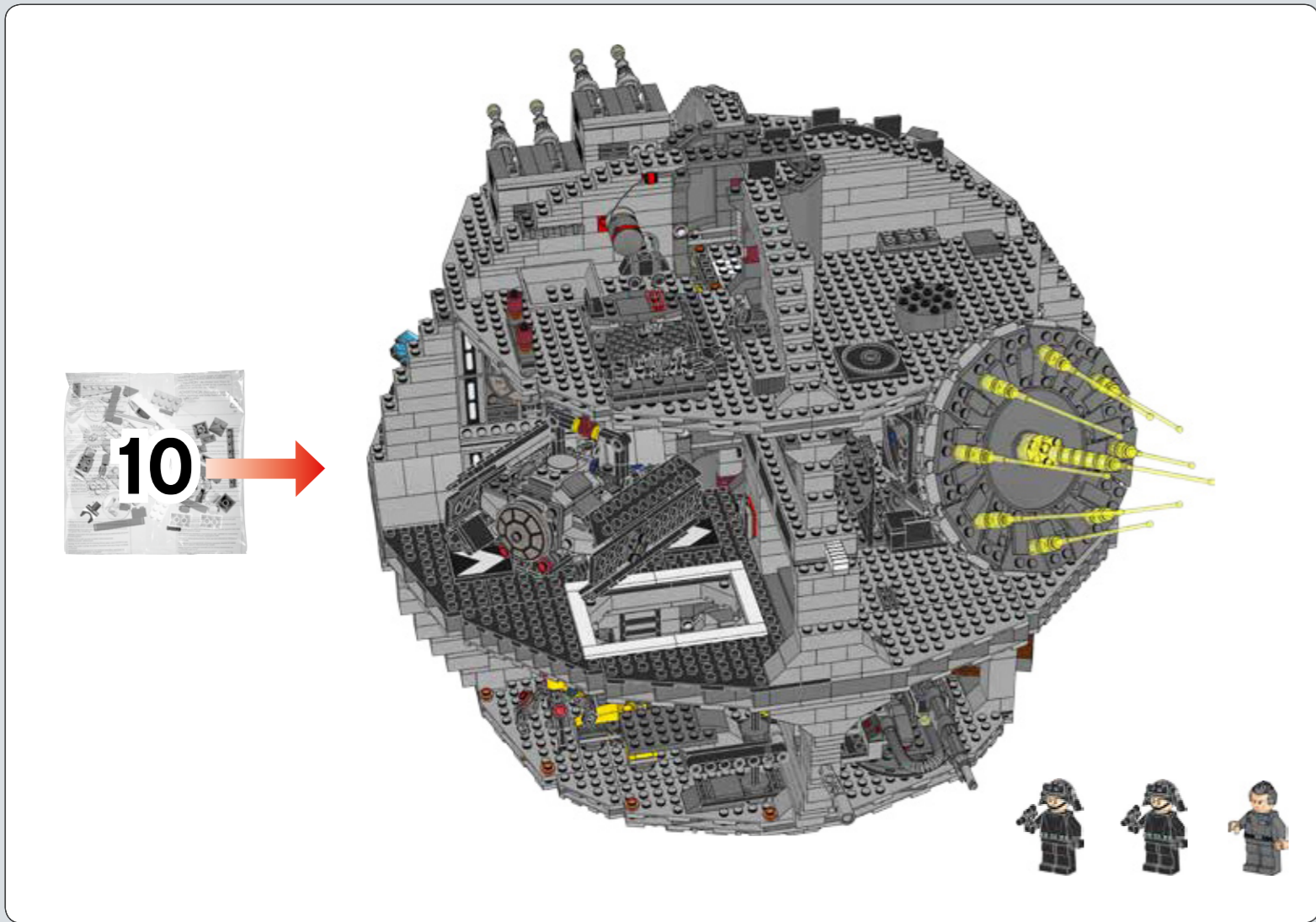

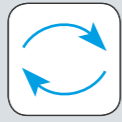
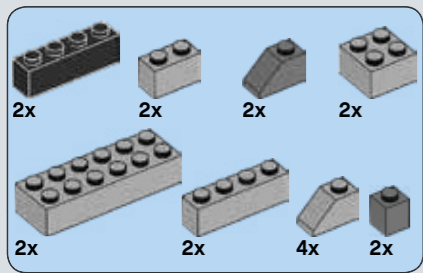

465

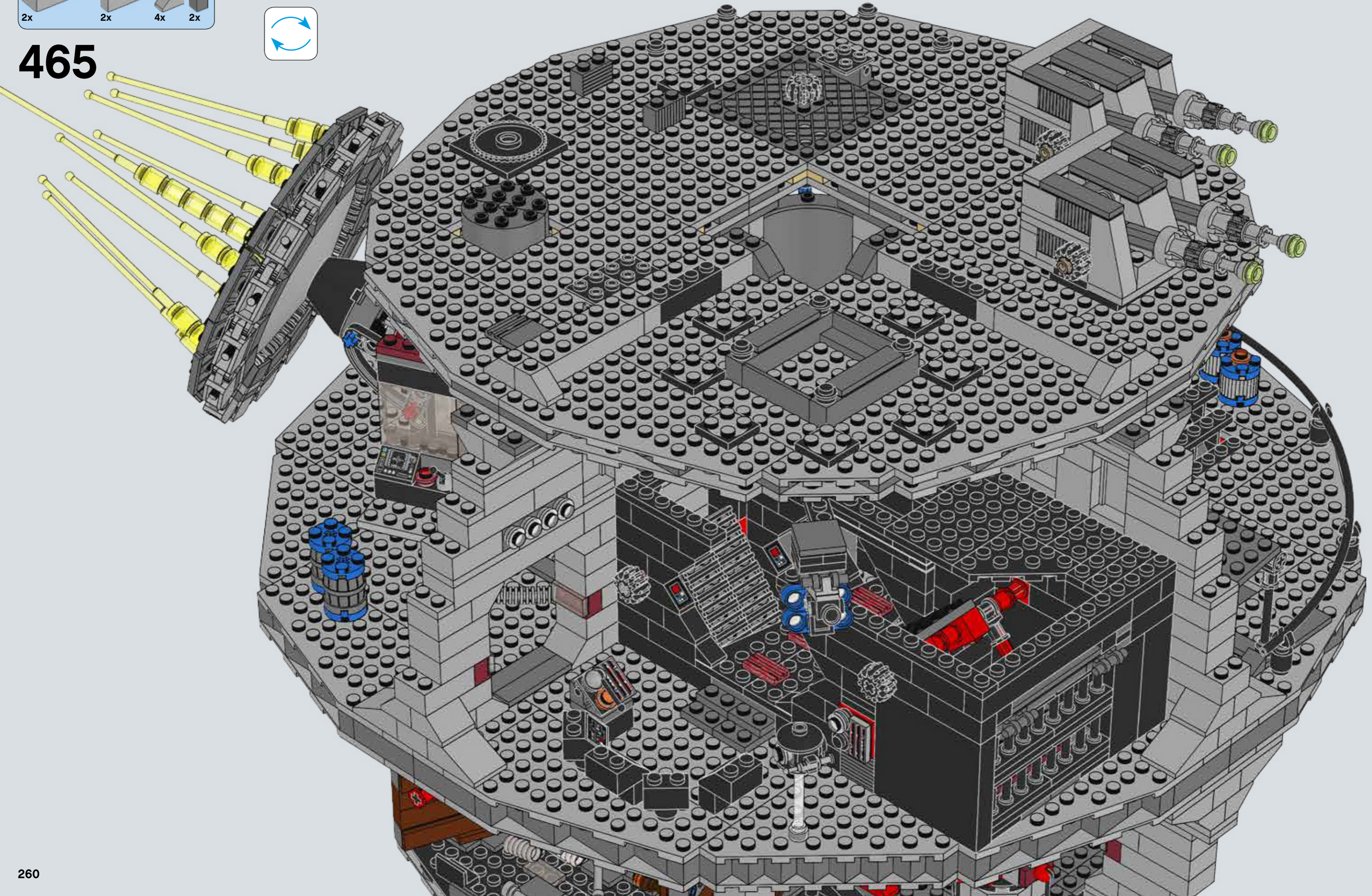

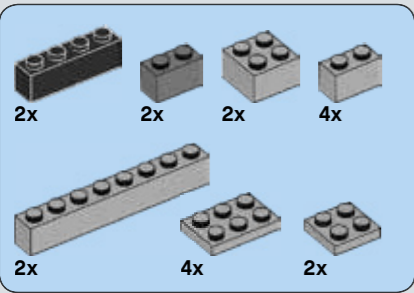

**466**

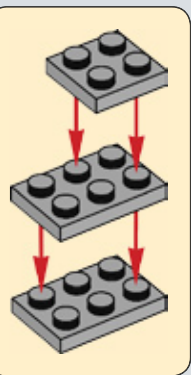
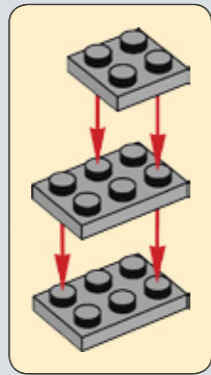

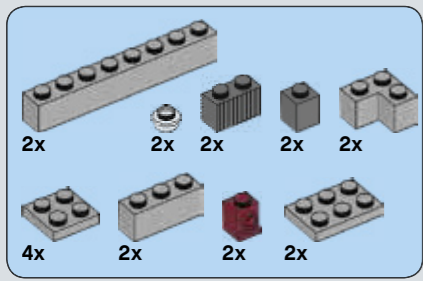

467

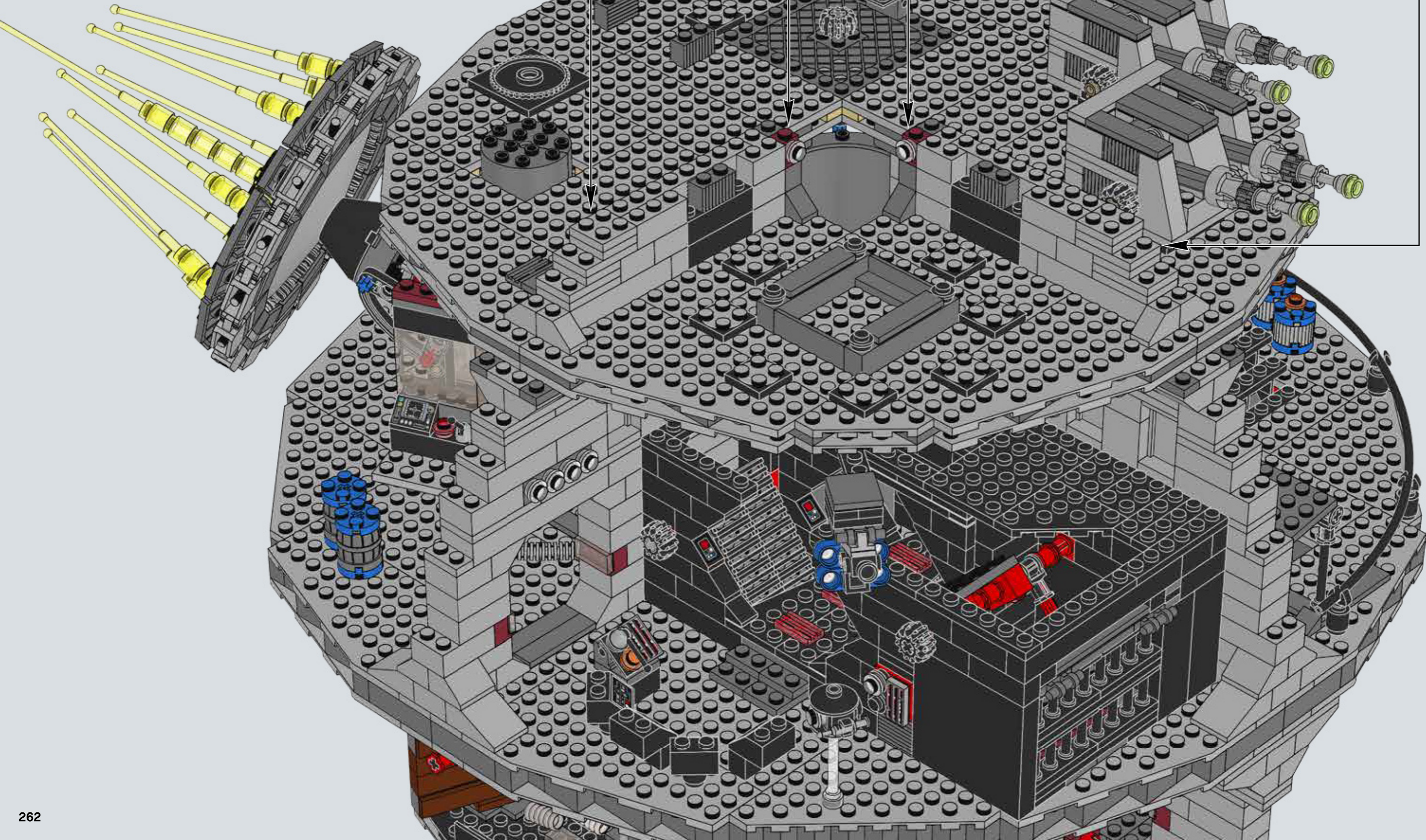
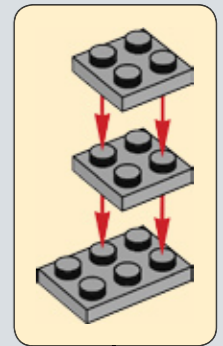
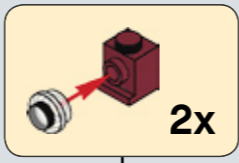
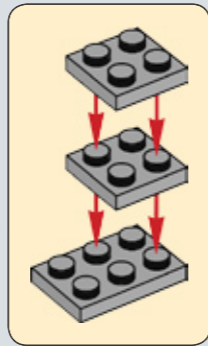

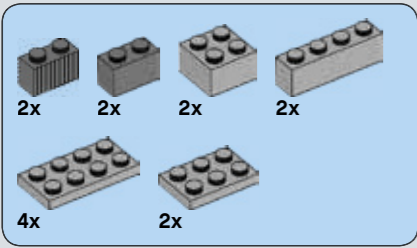

468

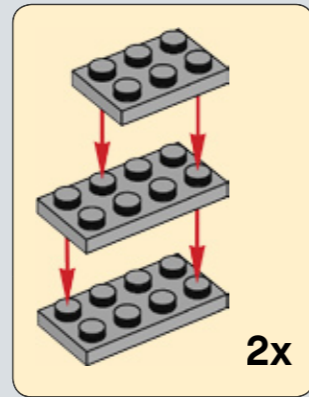

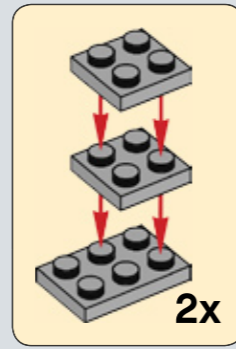
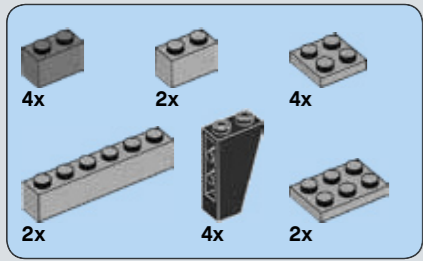

469





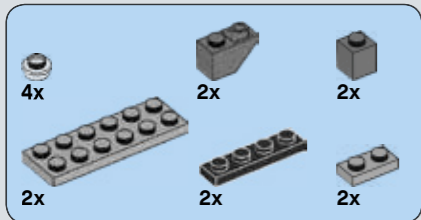

470

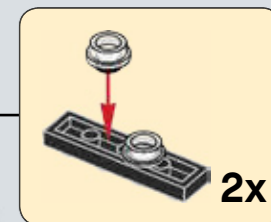
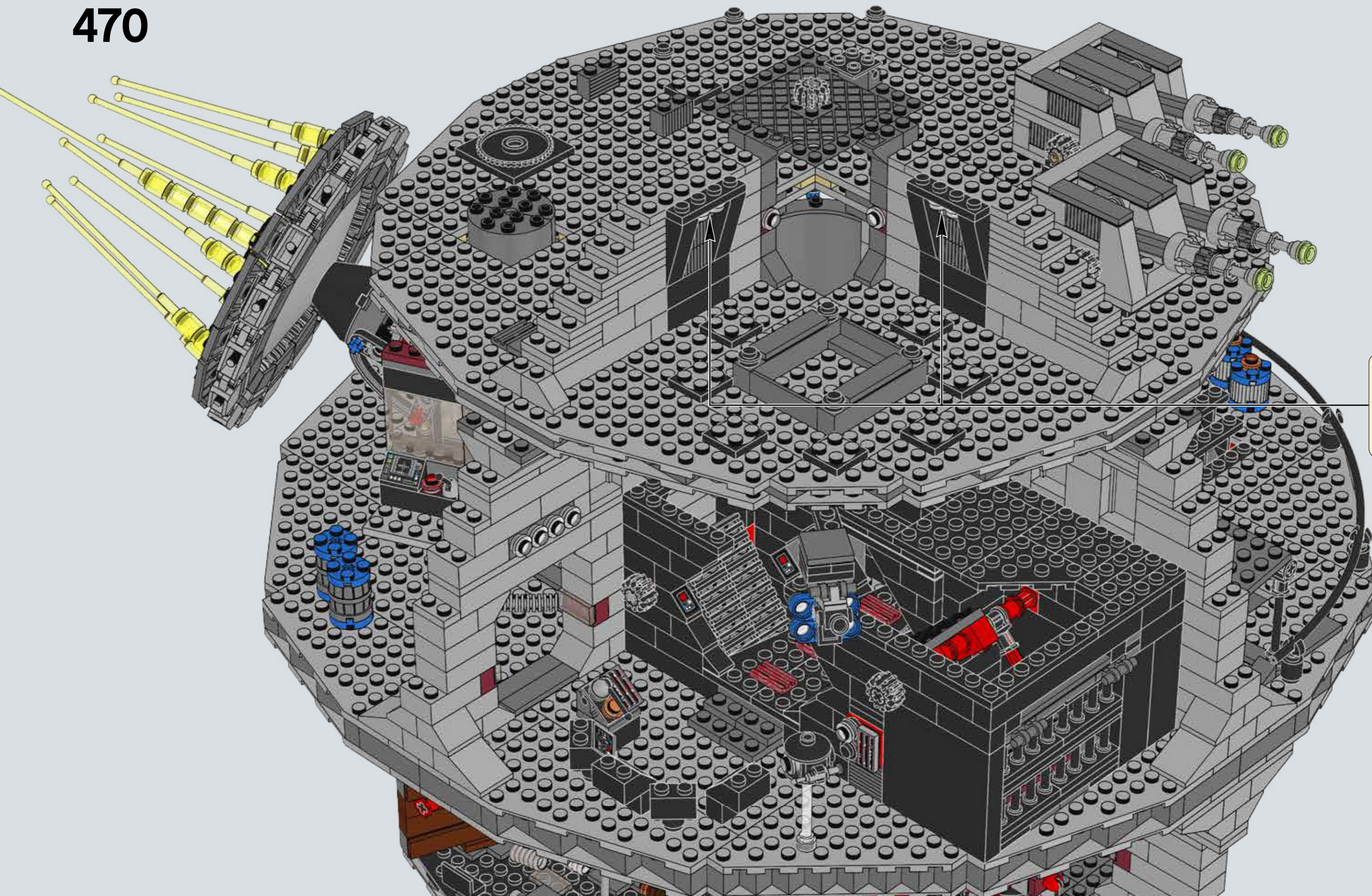

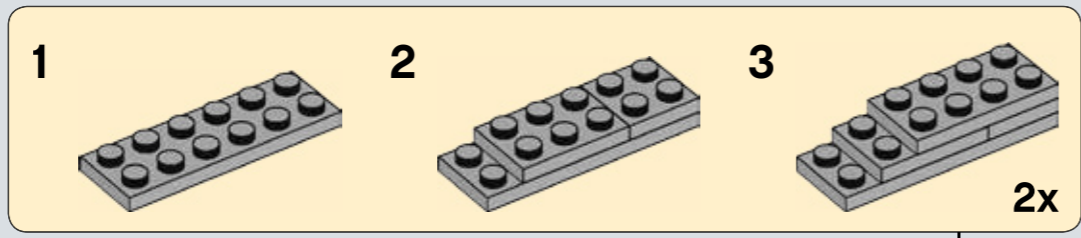
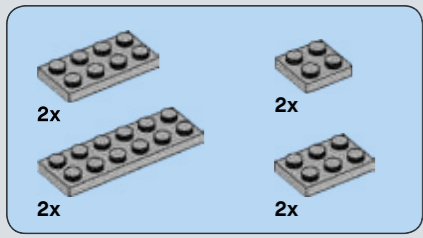

471

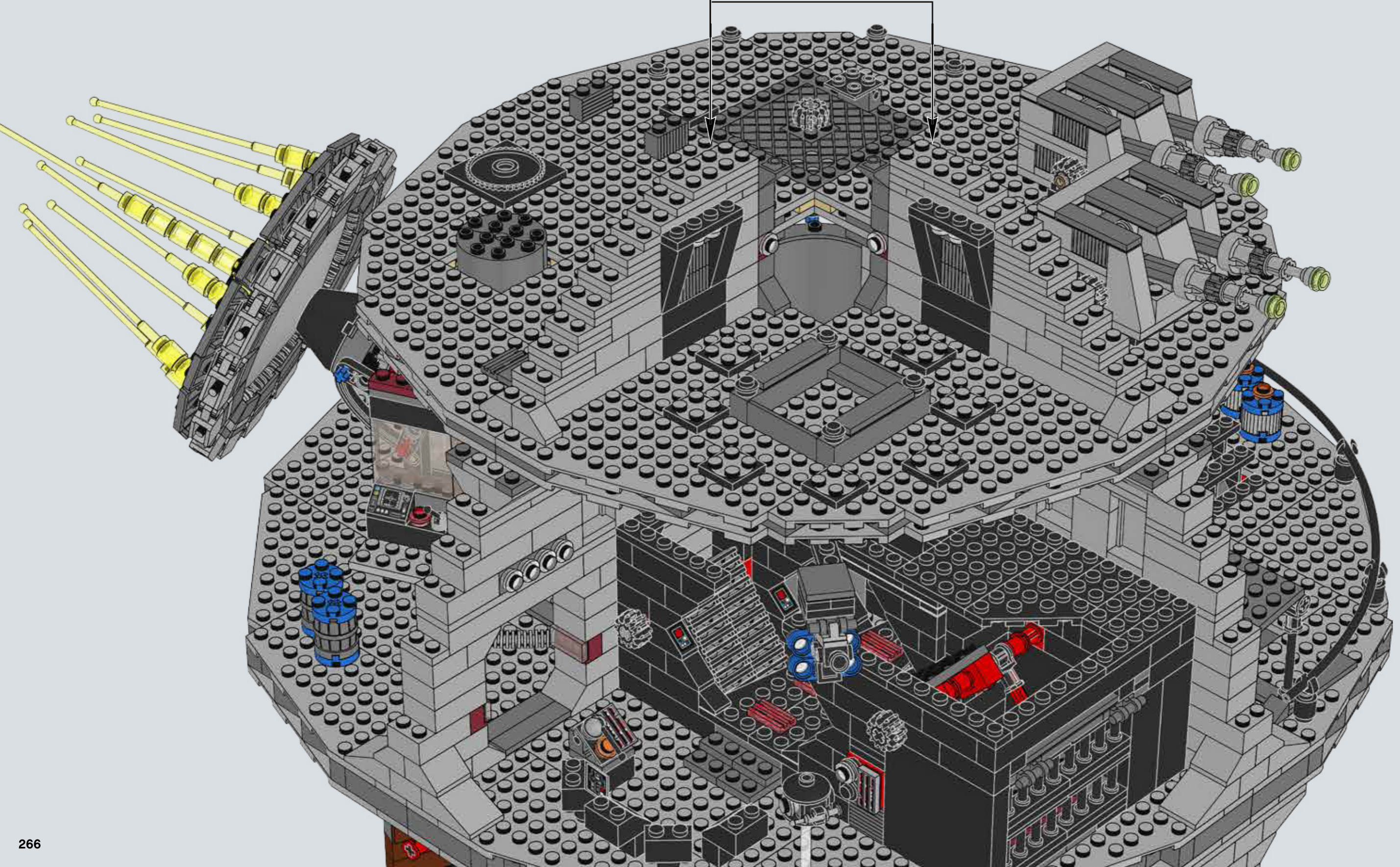

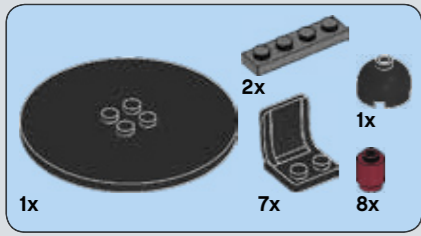

472

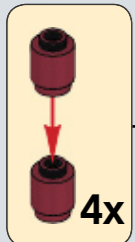
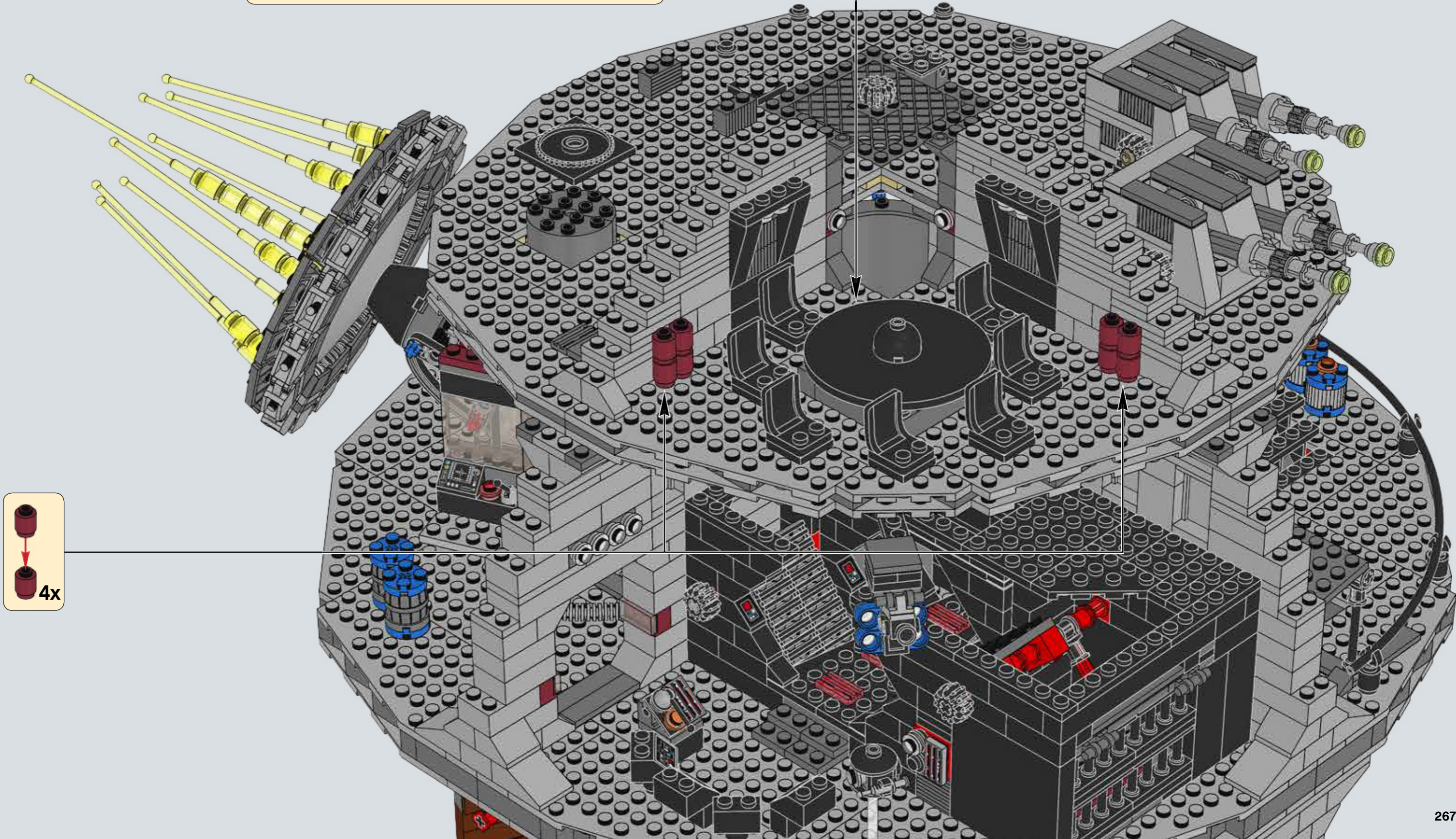
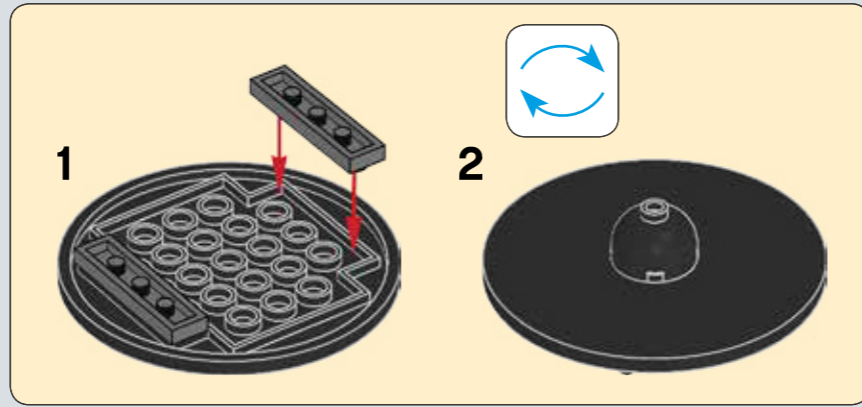

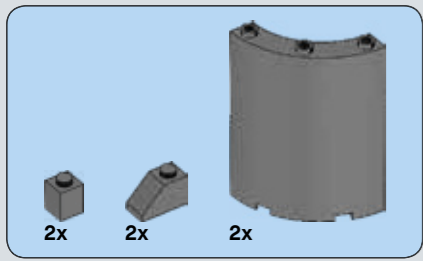

# 473

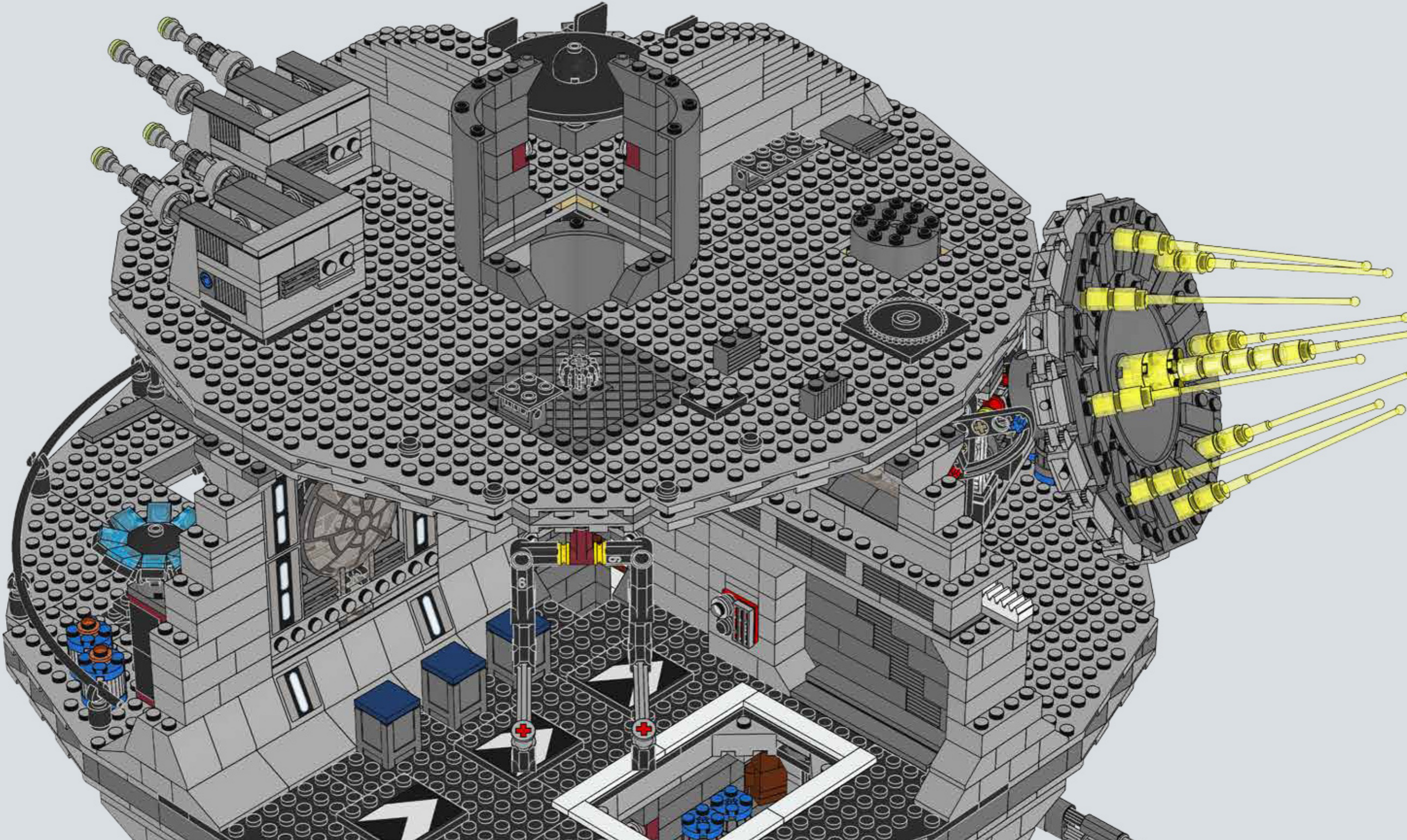

- 2x
- 5x
- 4x
- 4x
- 2x

474

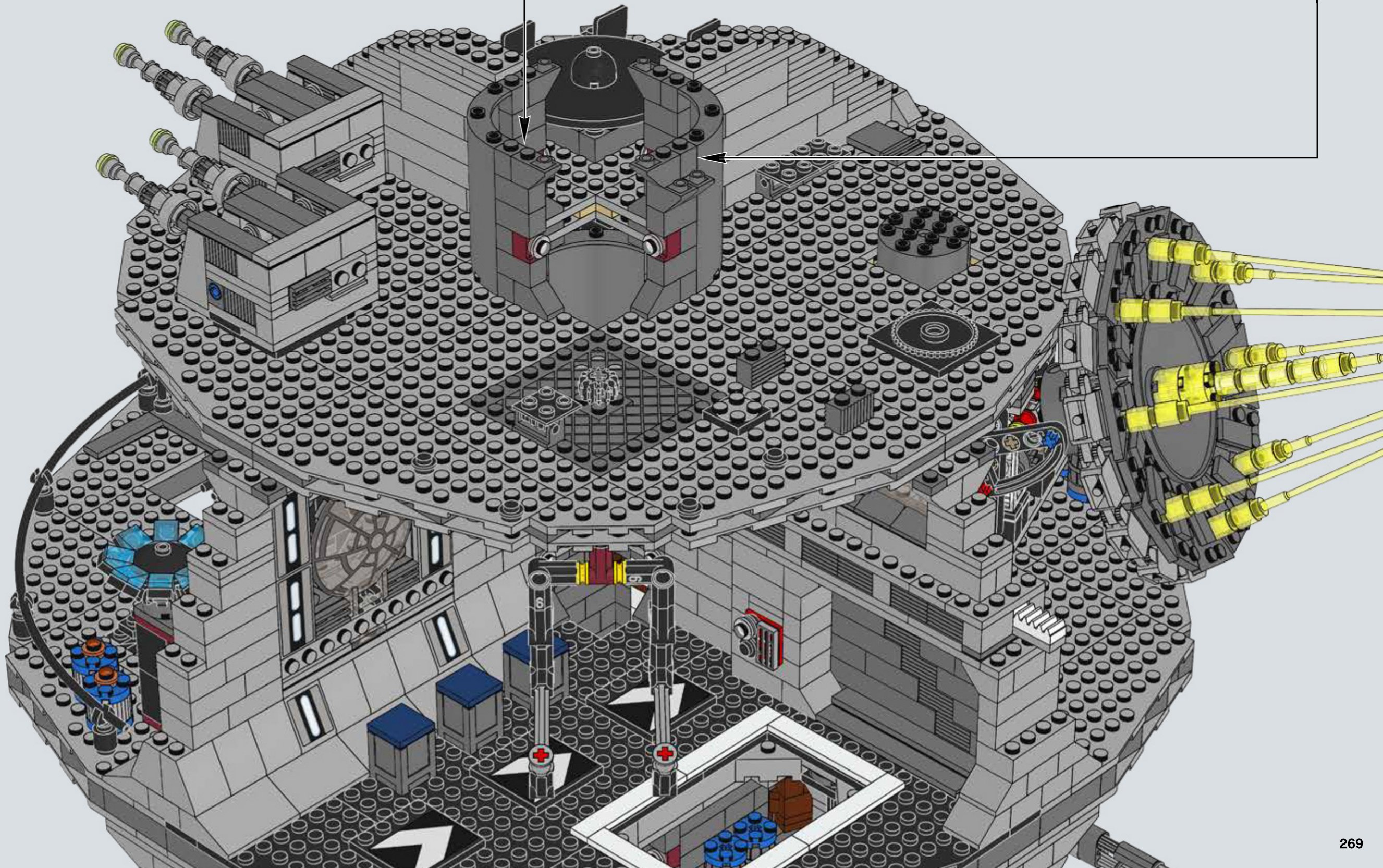
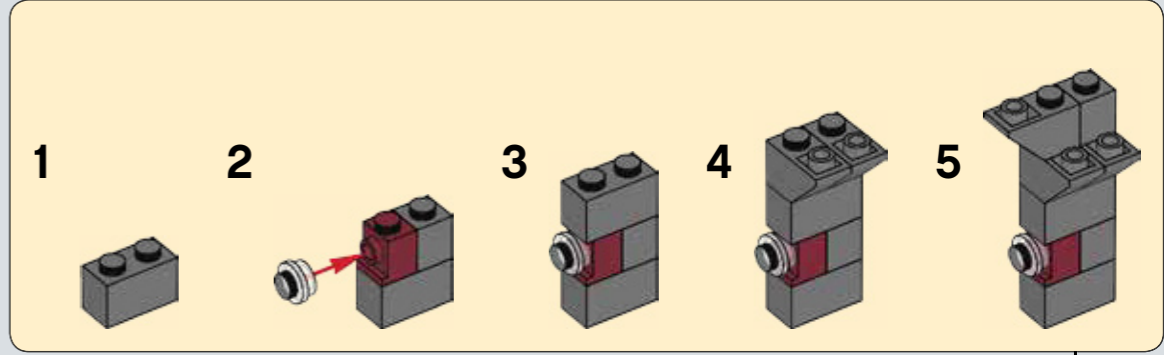
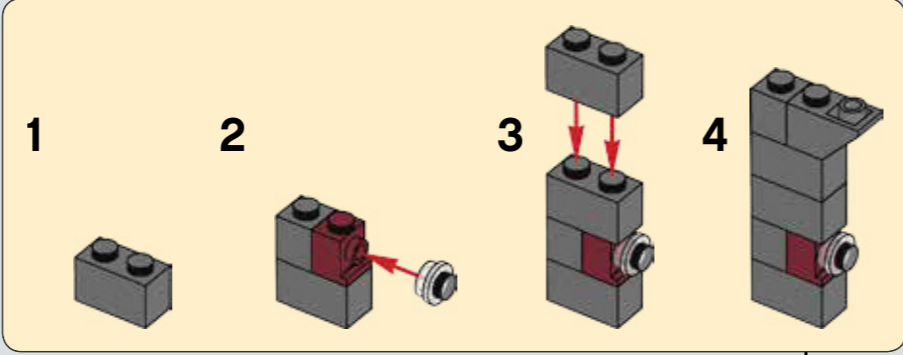

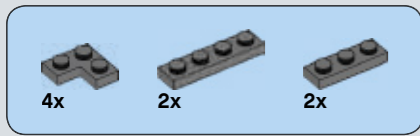

# 475

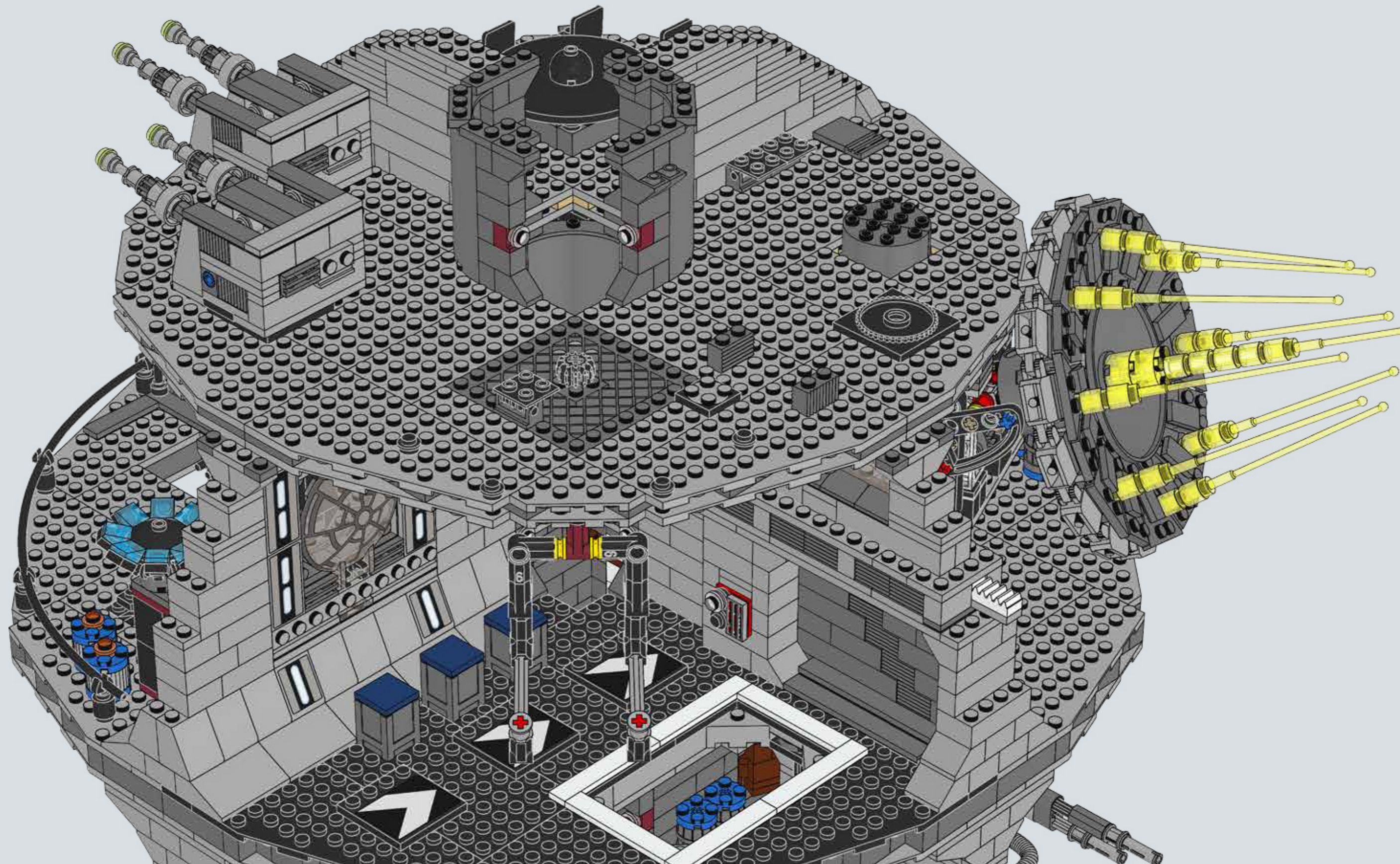

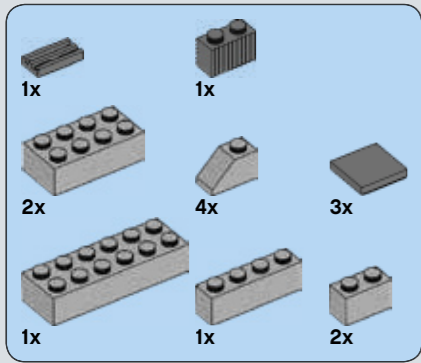

476

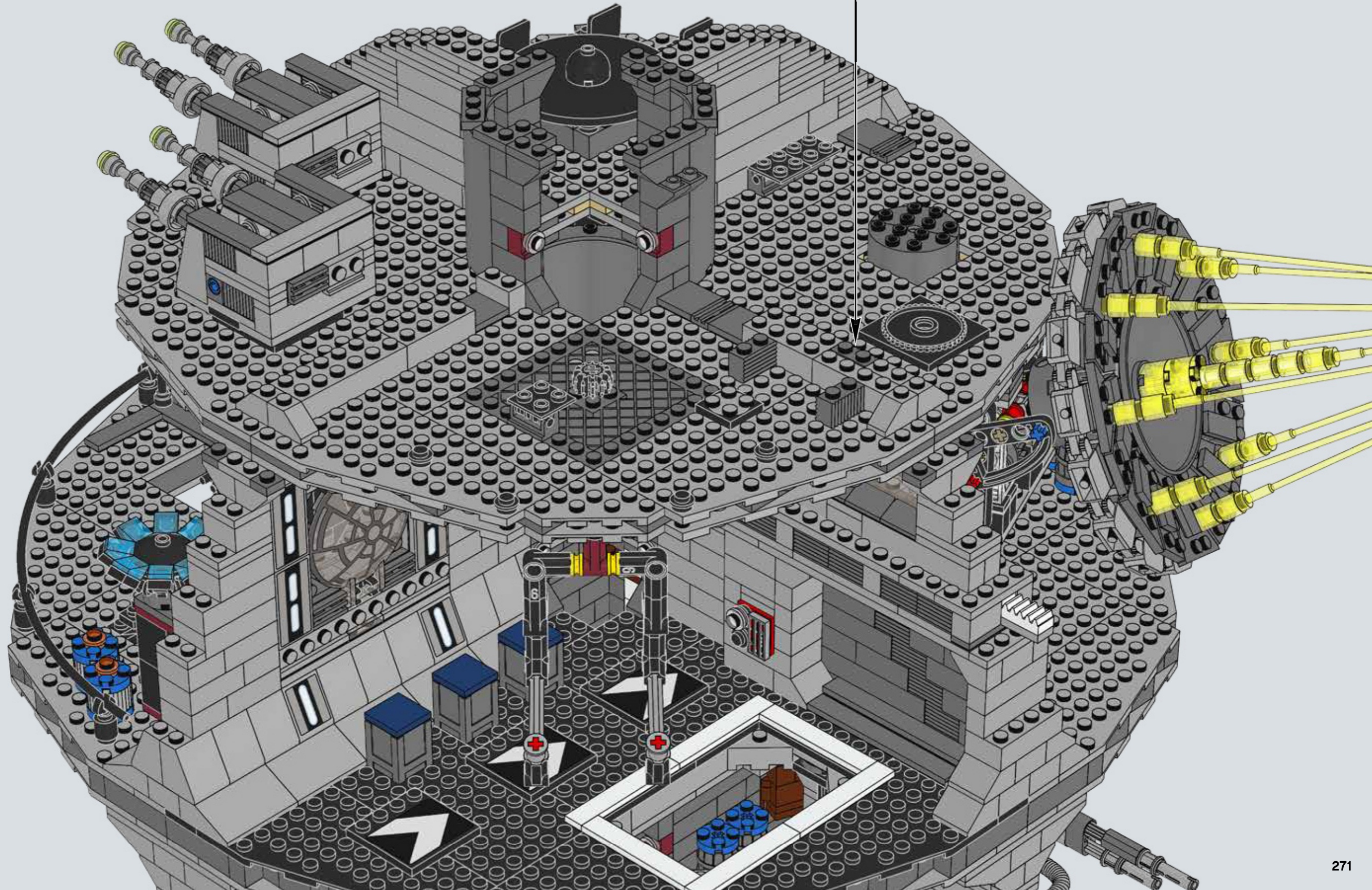
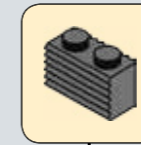

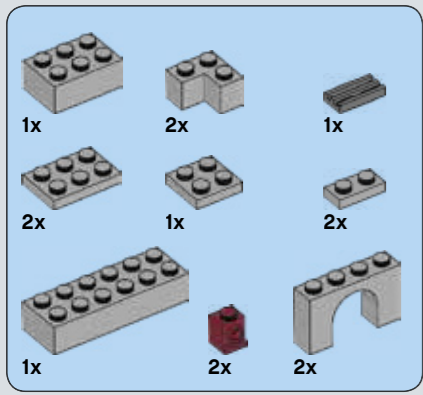

477

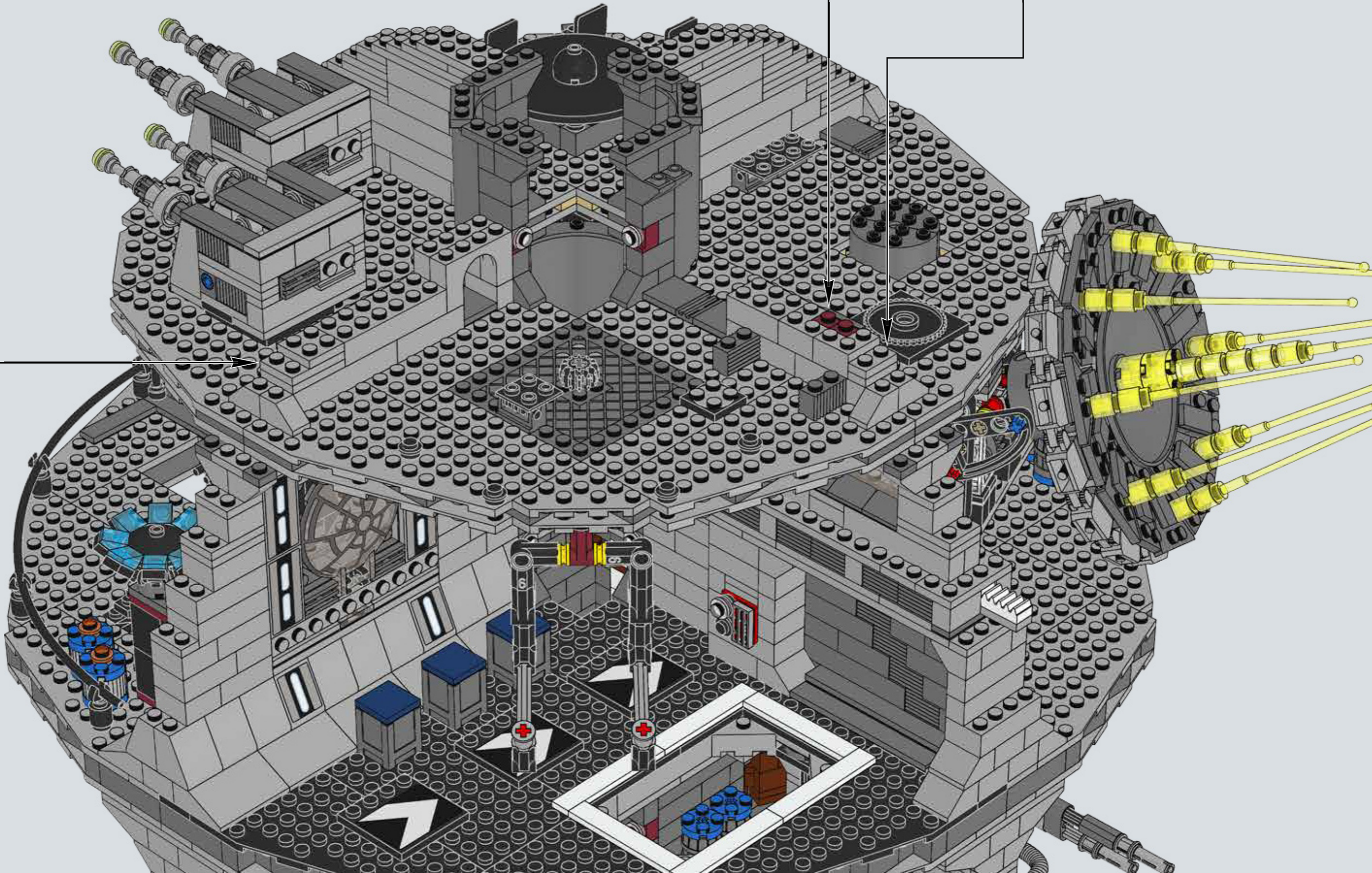
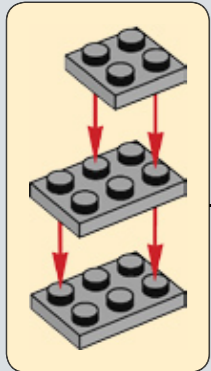



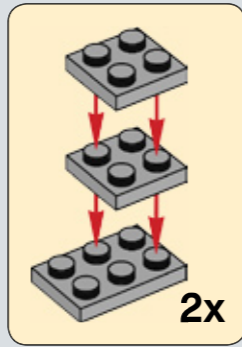
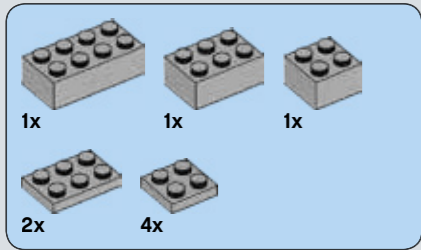

478

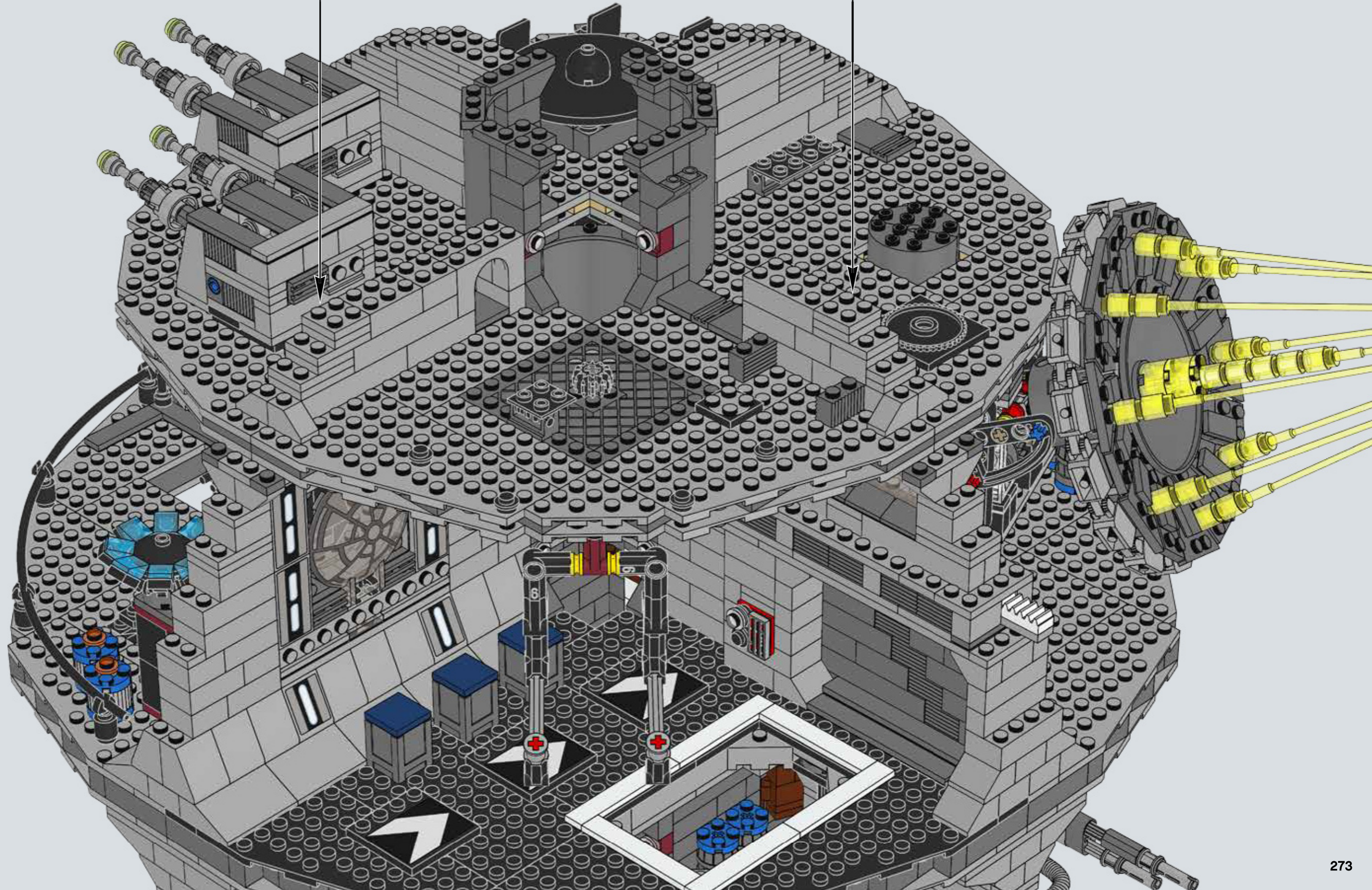

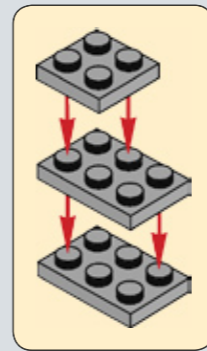
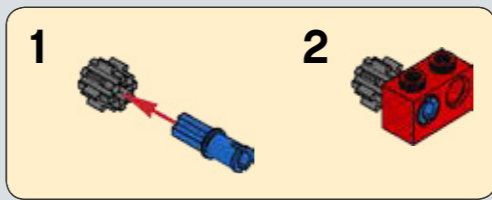
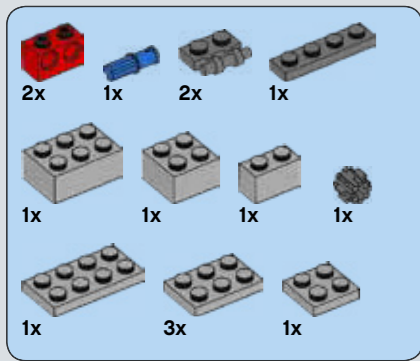

# 479

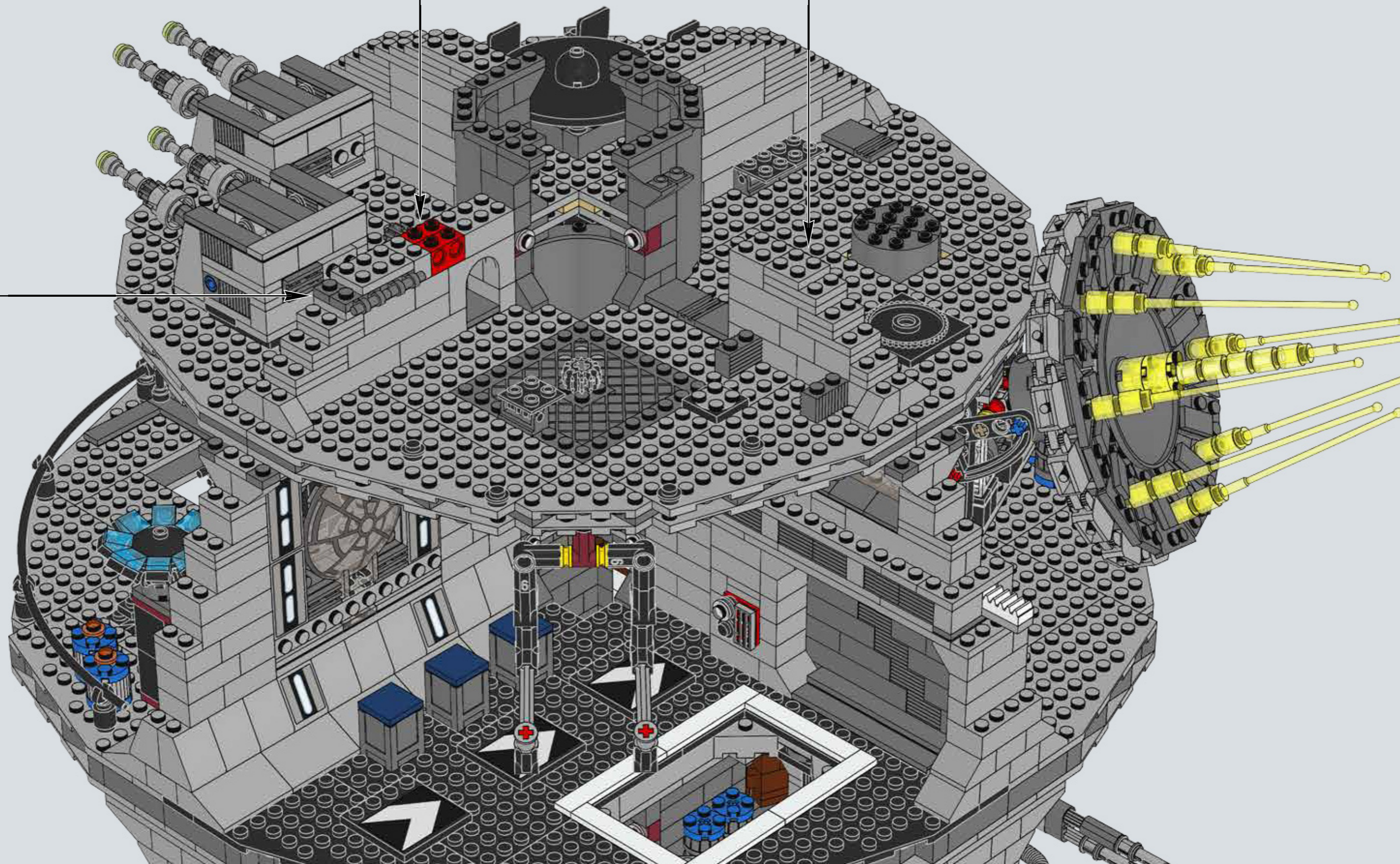
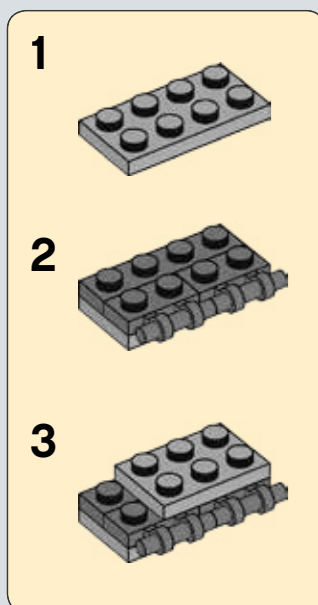

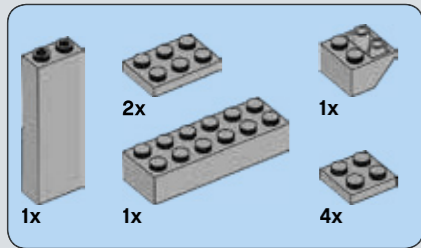

480

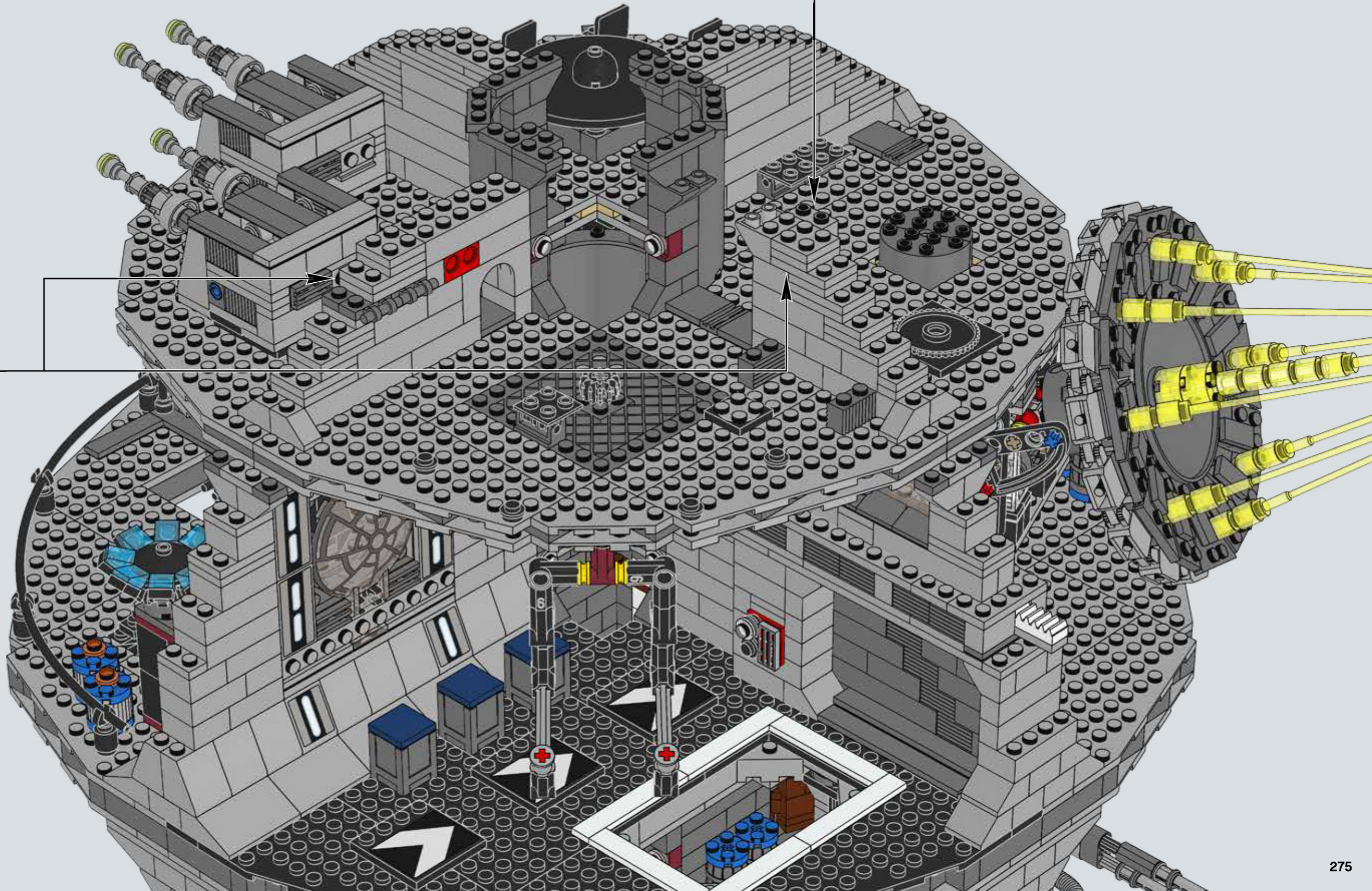
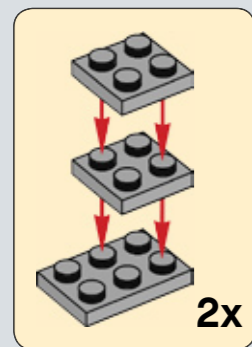
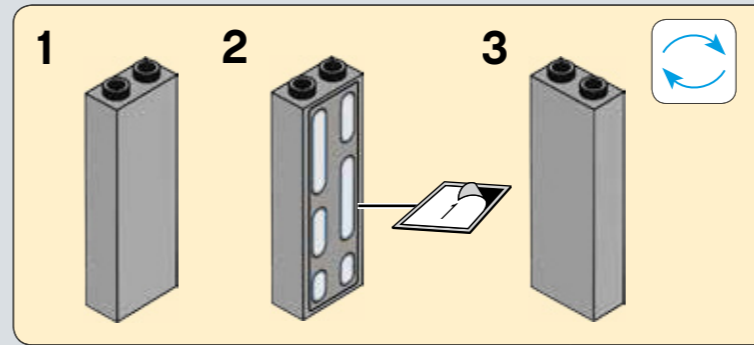

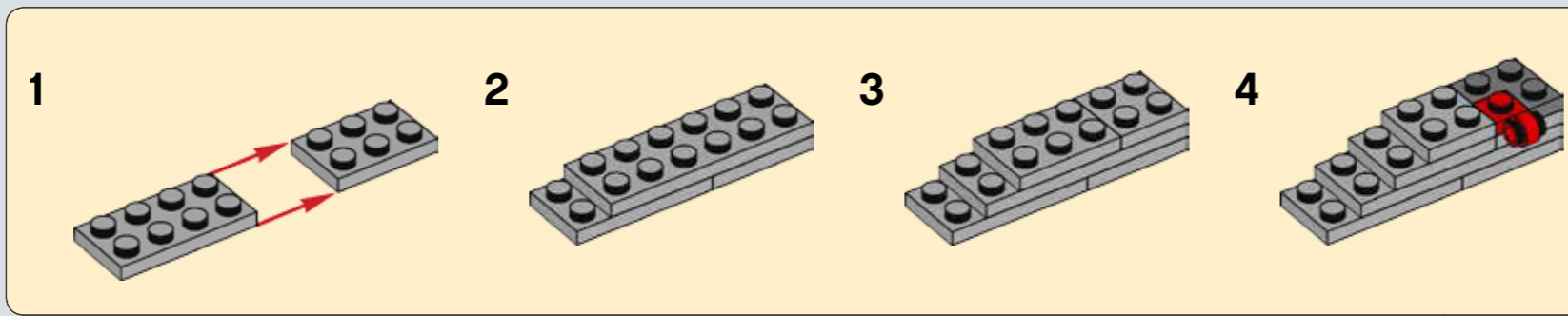
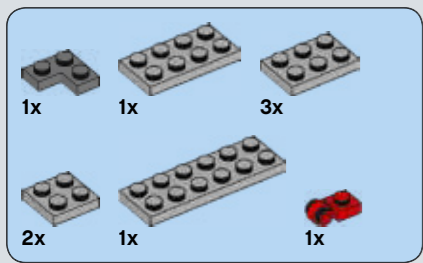

481

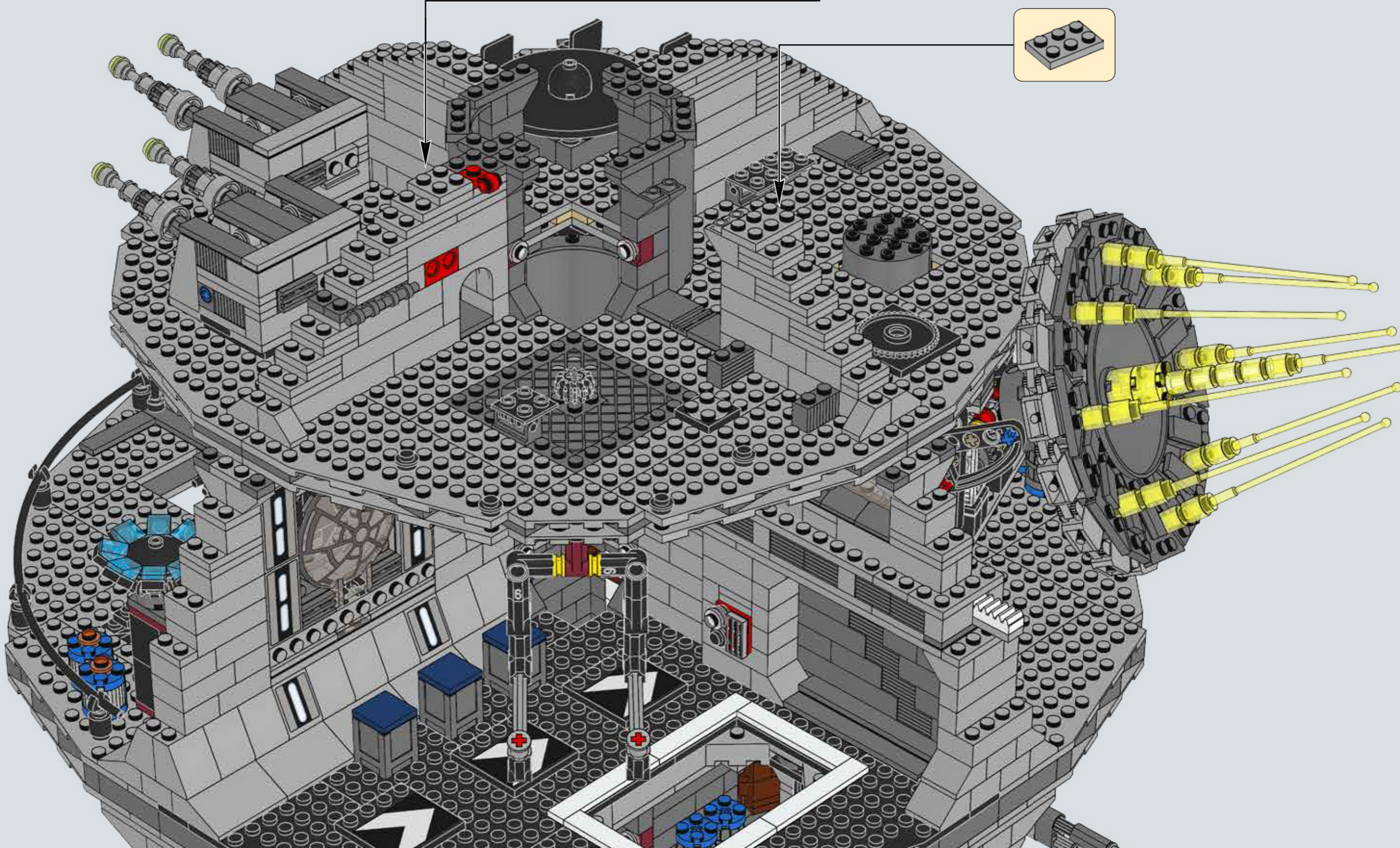

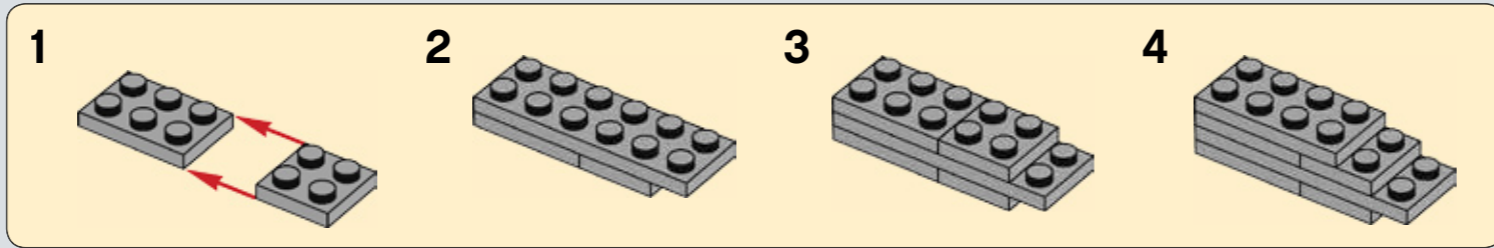
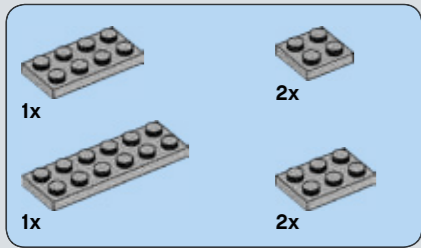

482

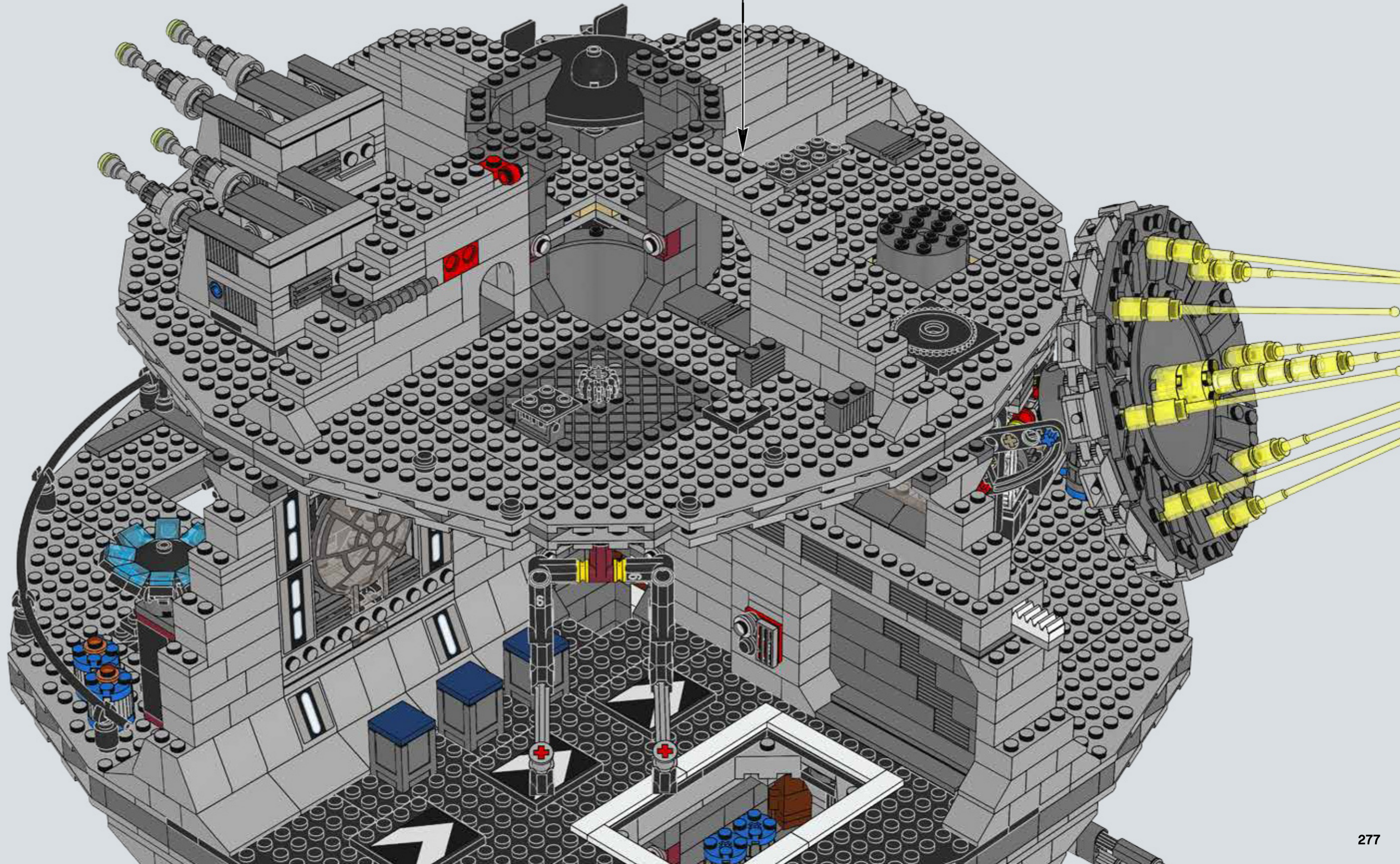



483

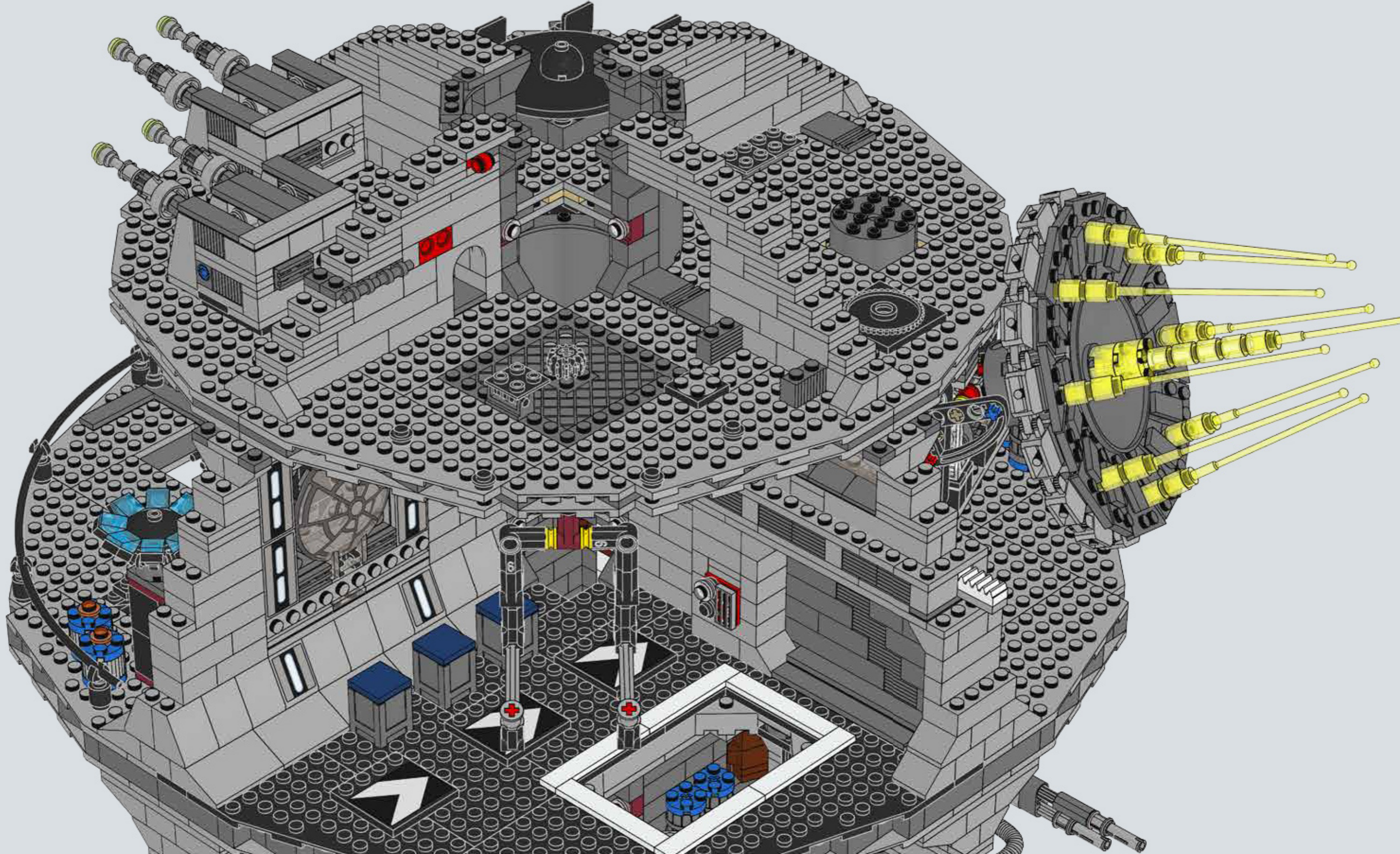

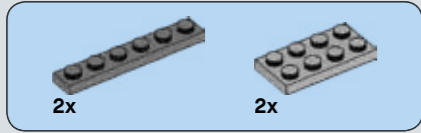
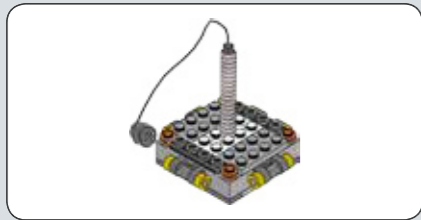

484

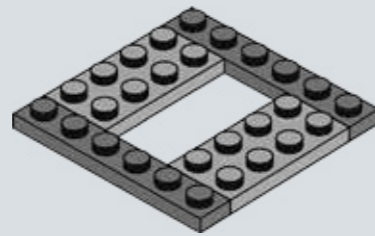

485

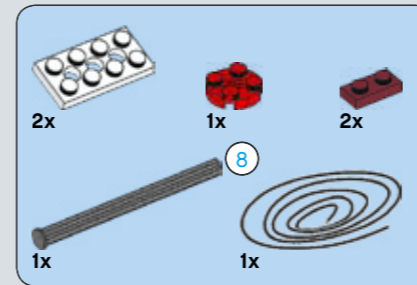
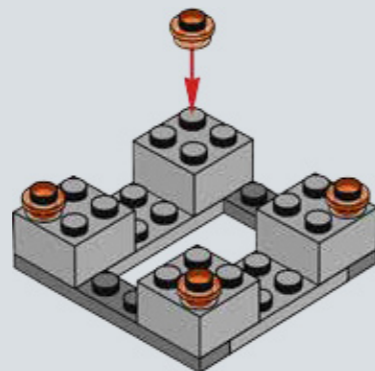

486

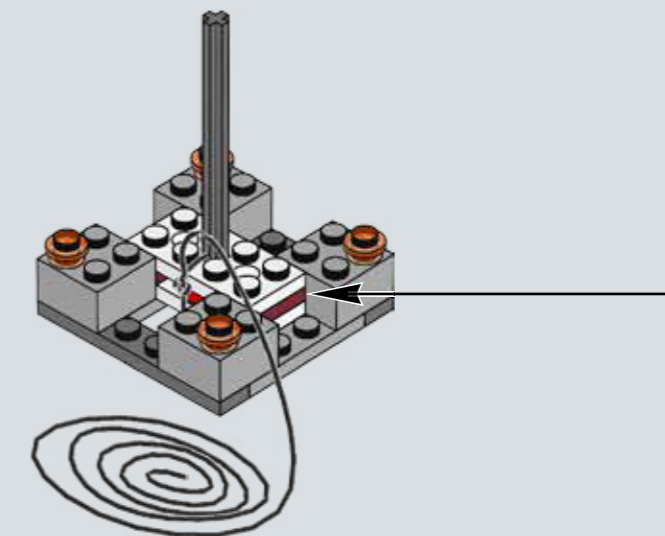
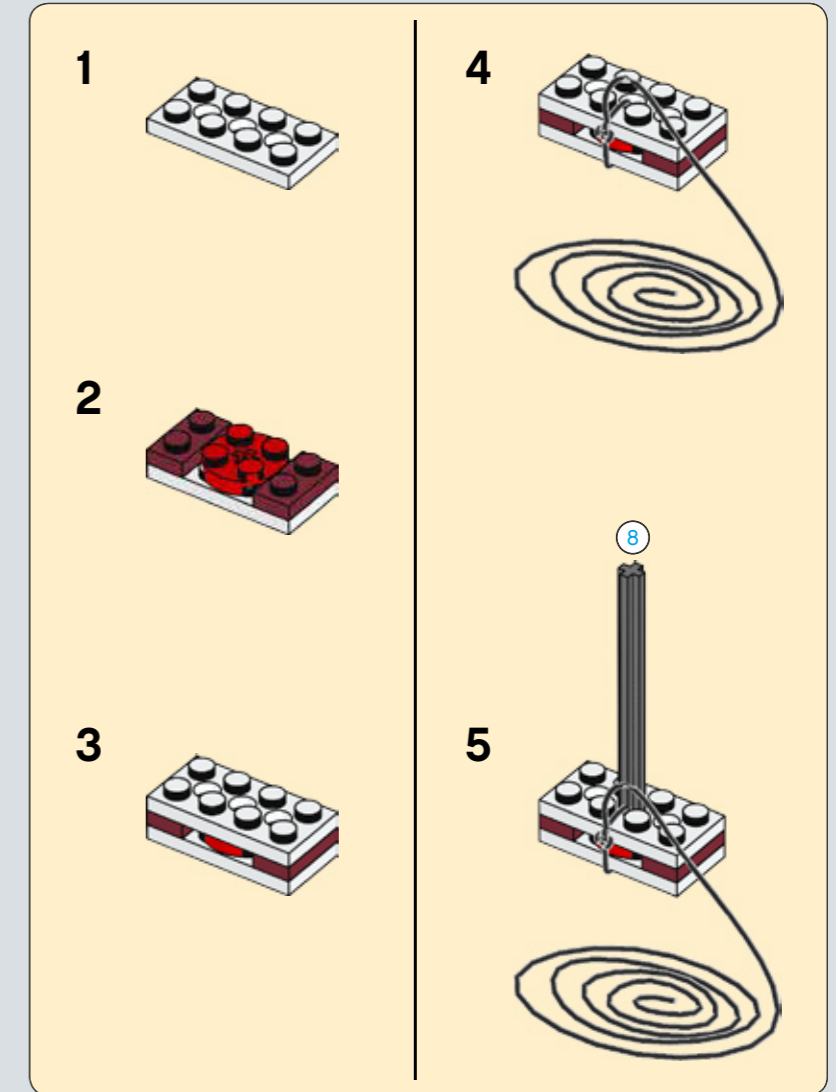
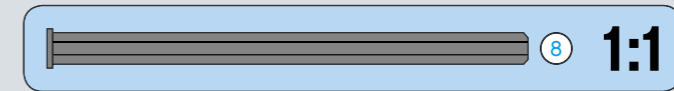

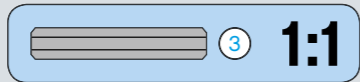
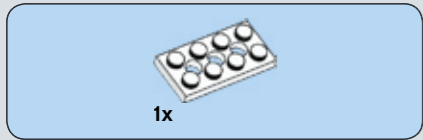

487

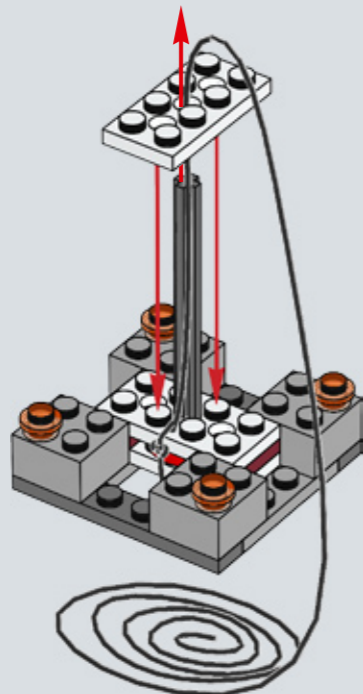

488

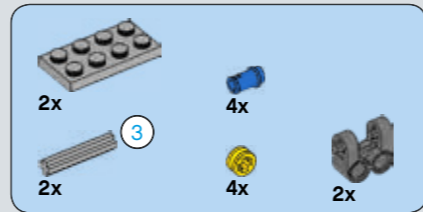
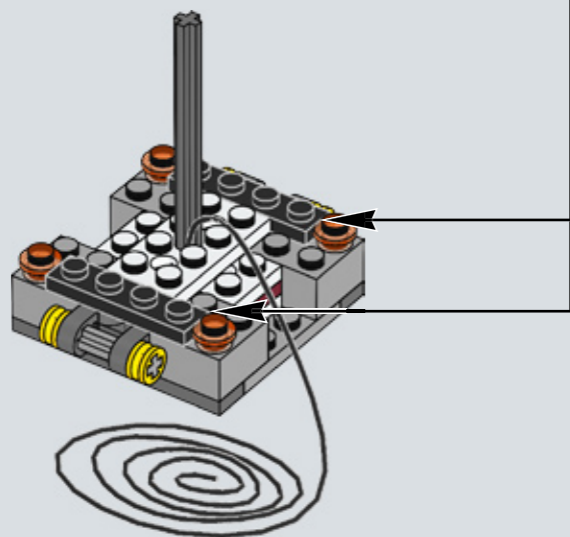

489

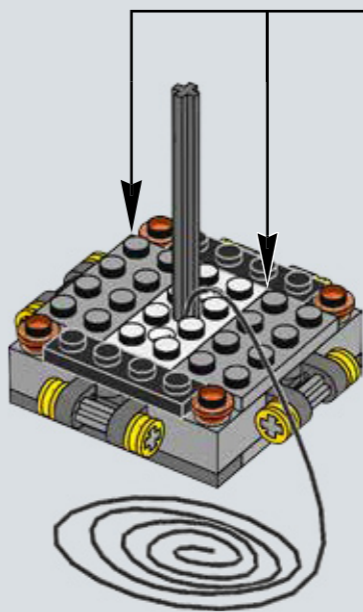

490

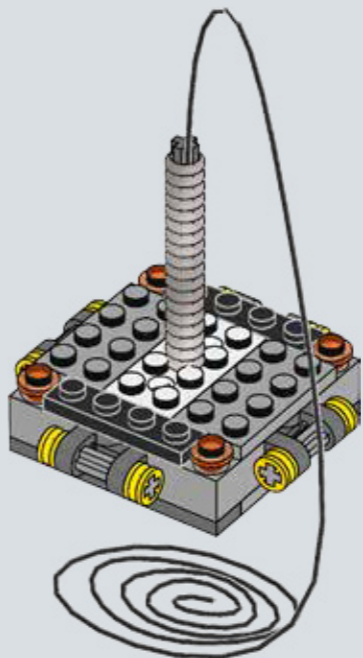



491

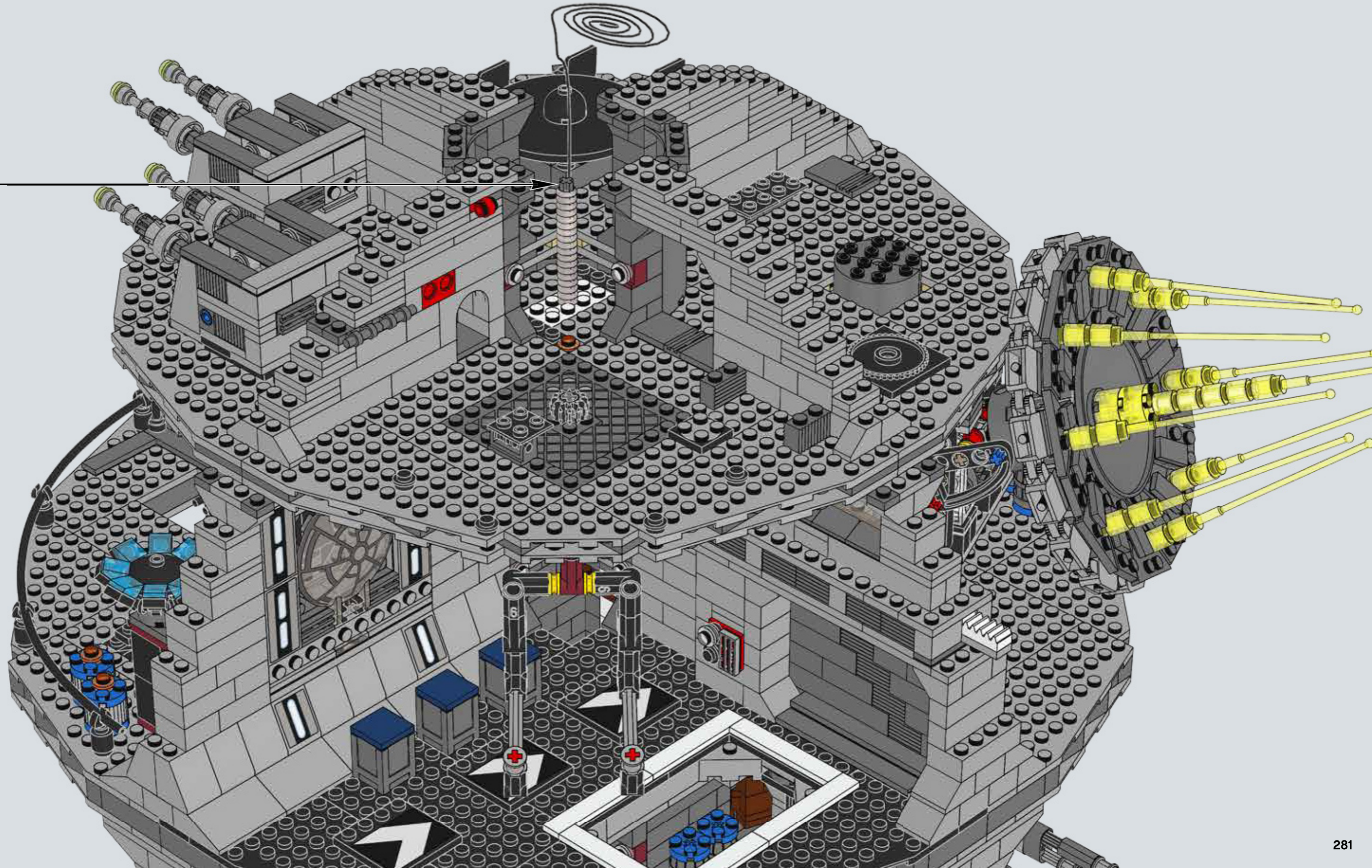

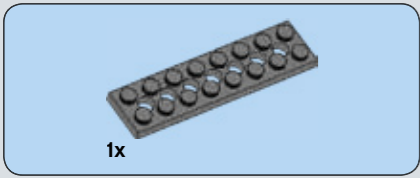

492

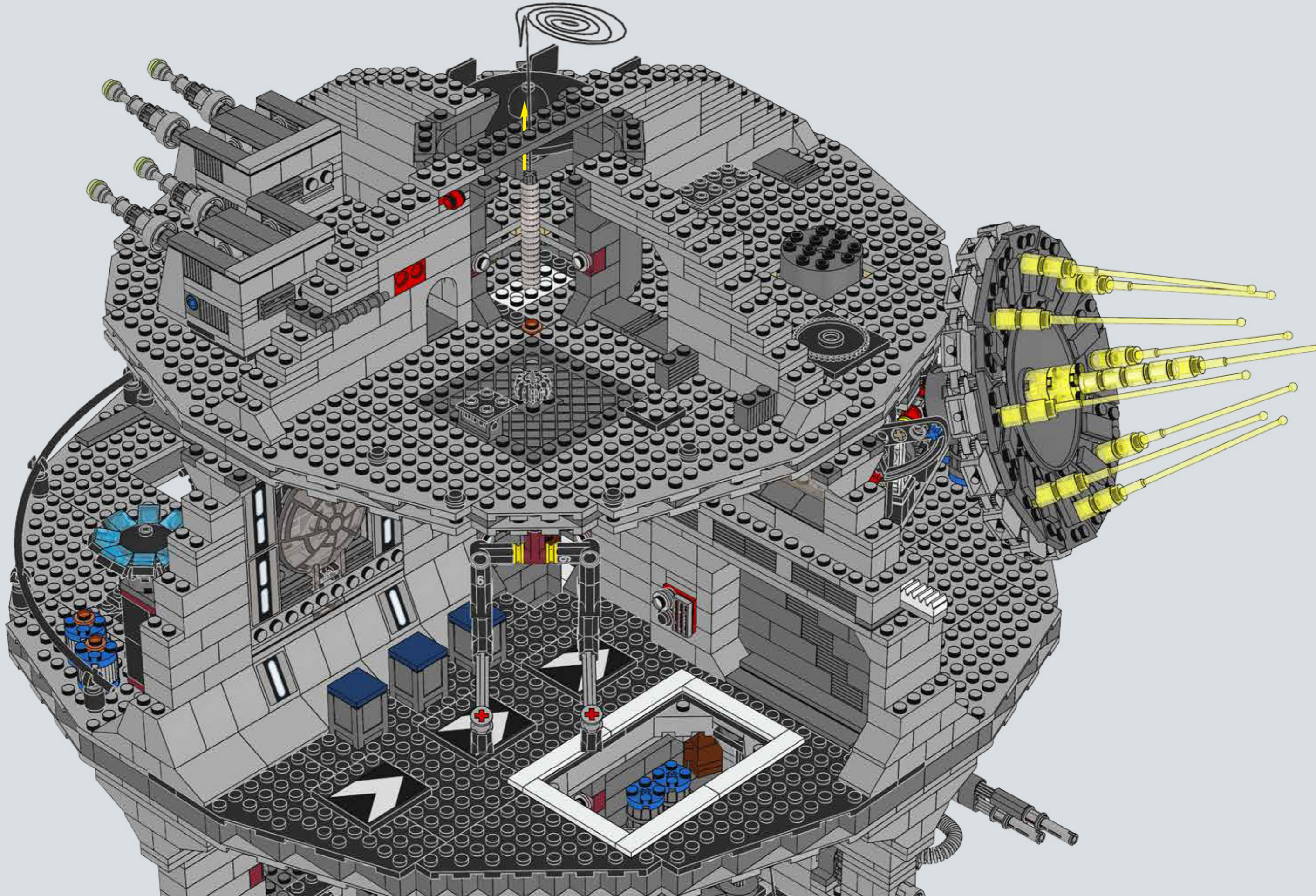

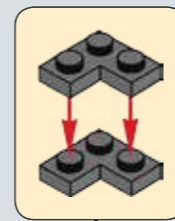
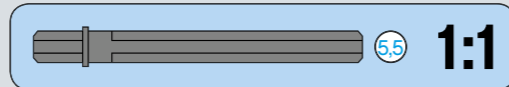
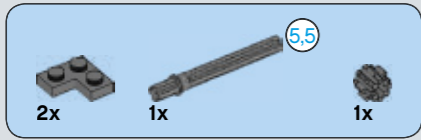

493

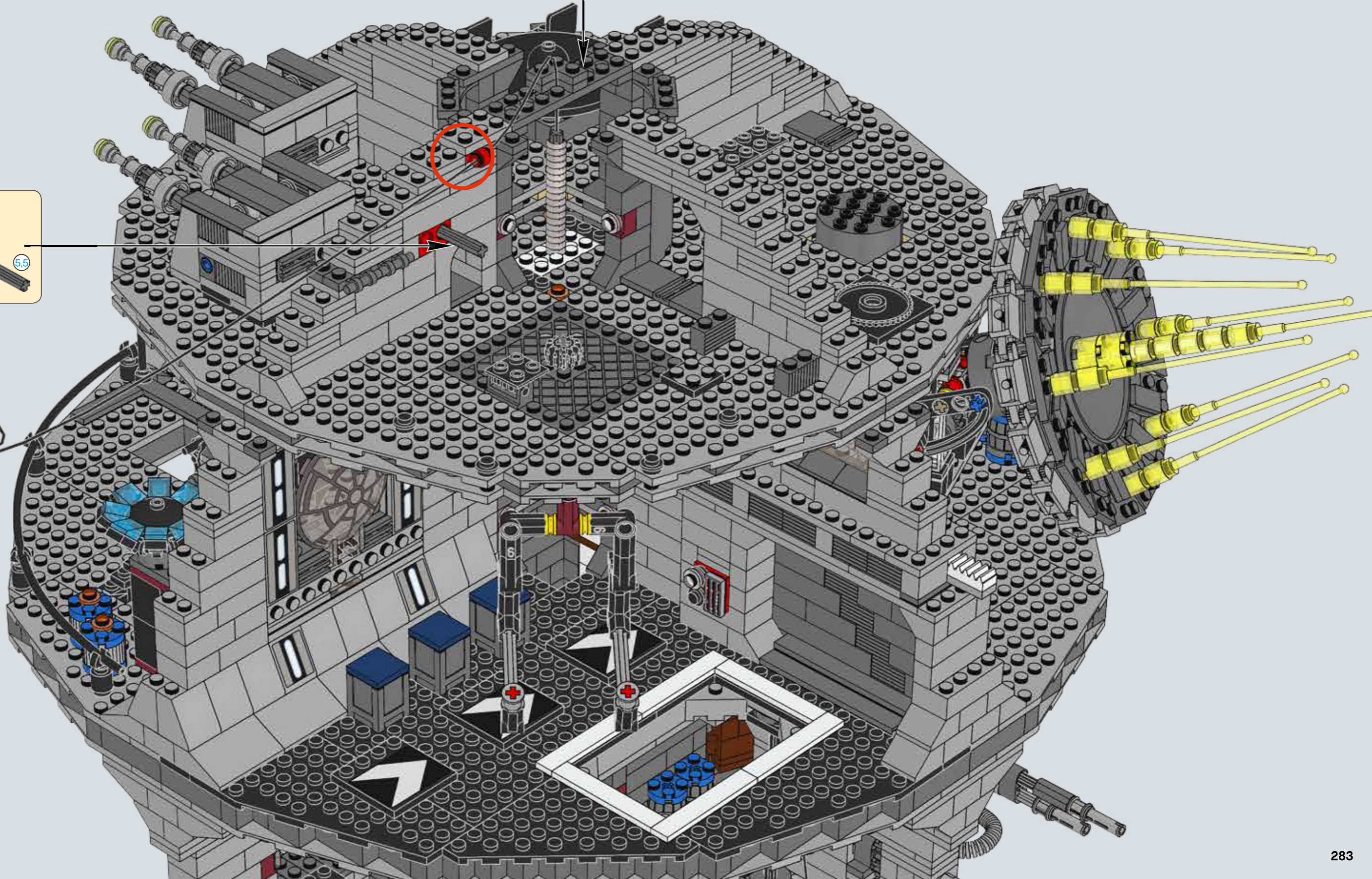
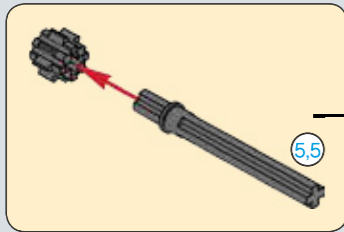

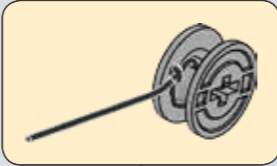

494

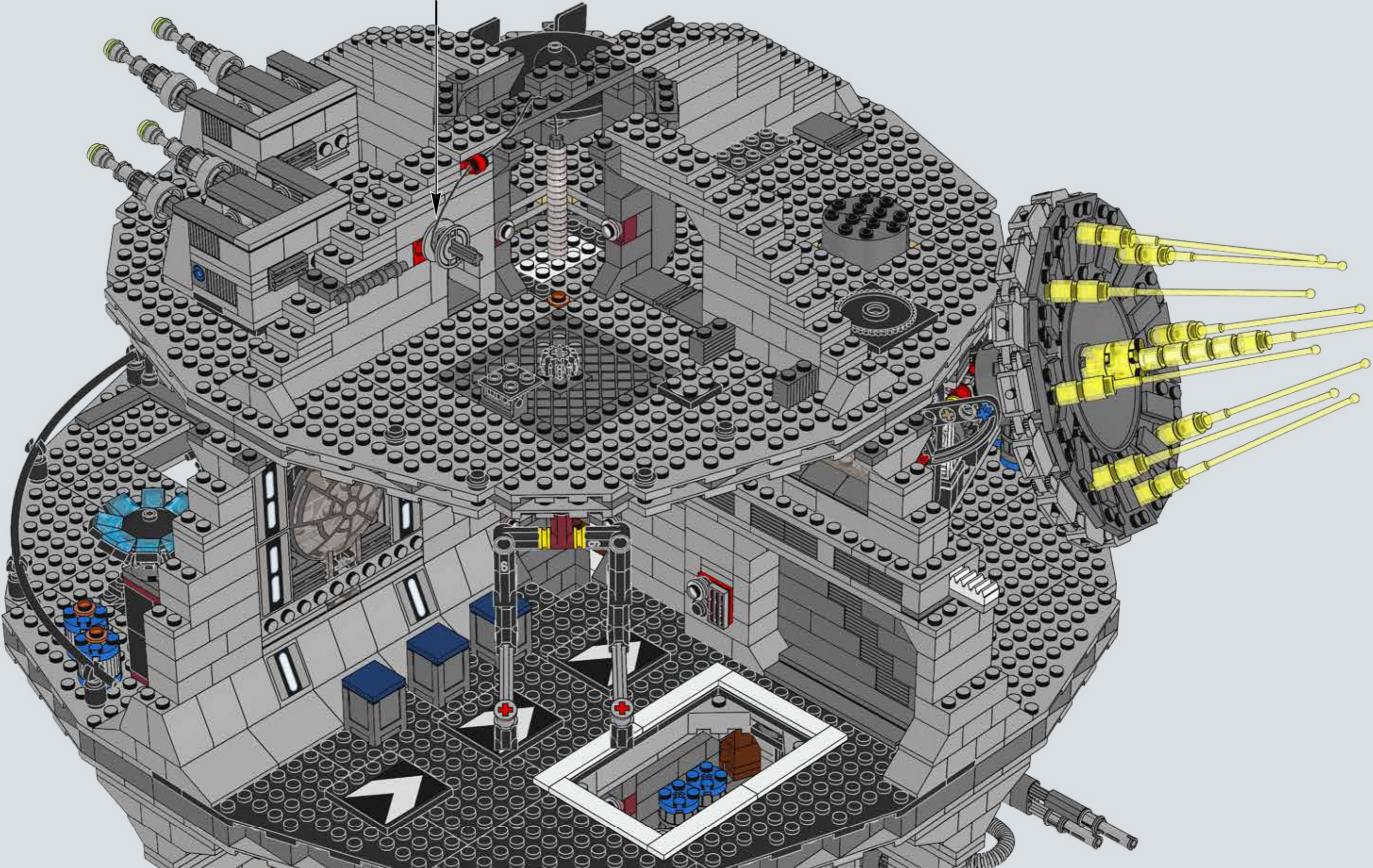



495

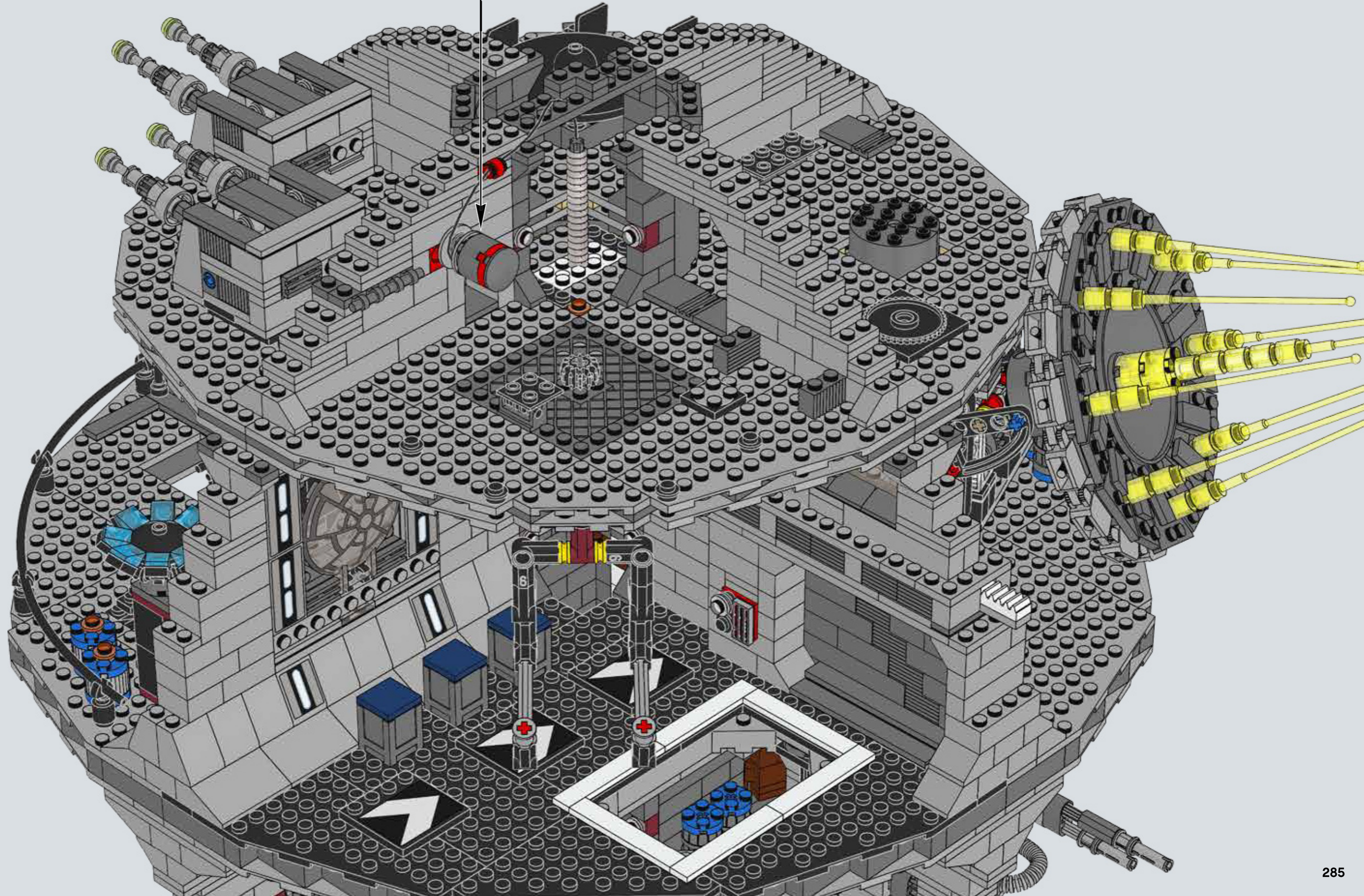
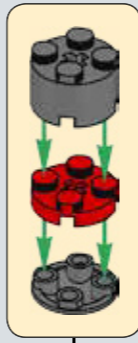

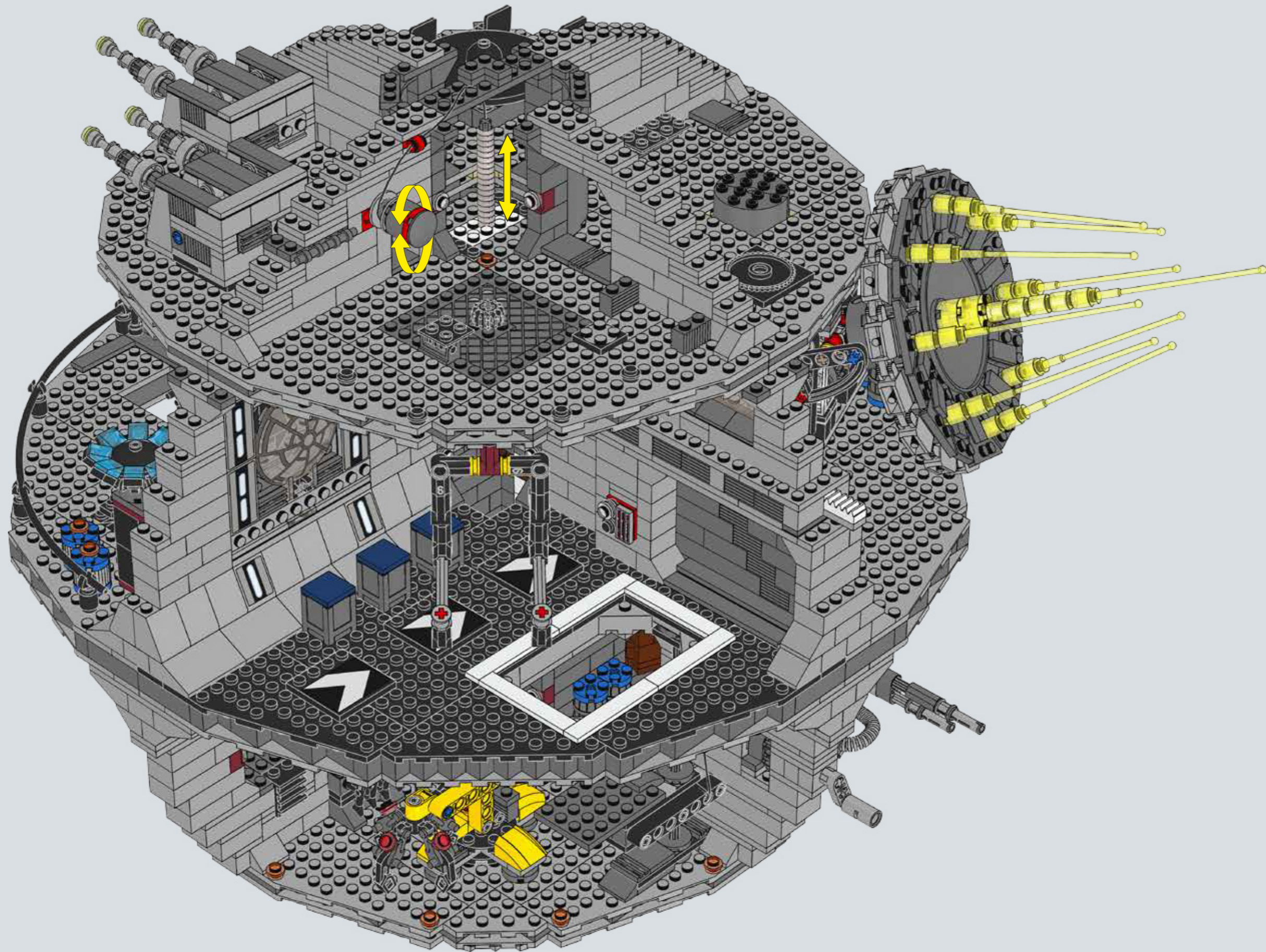

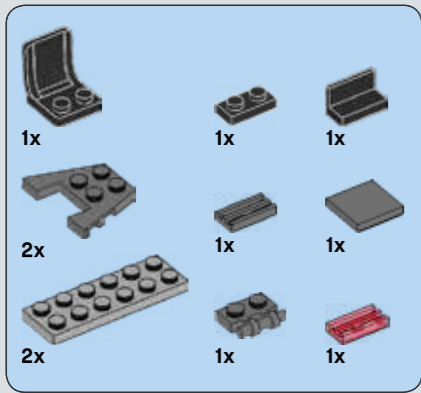

496

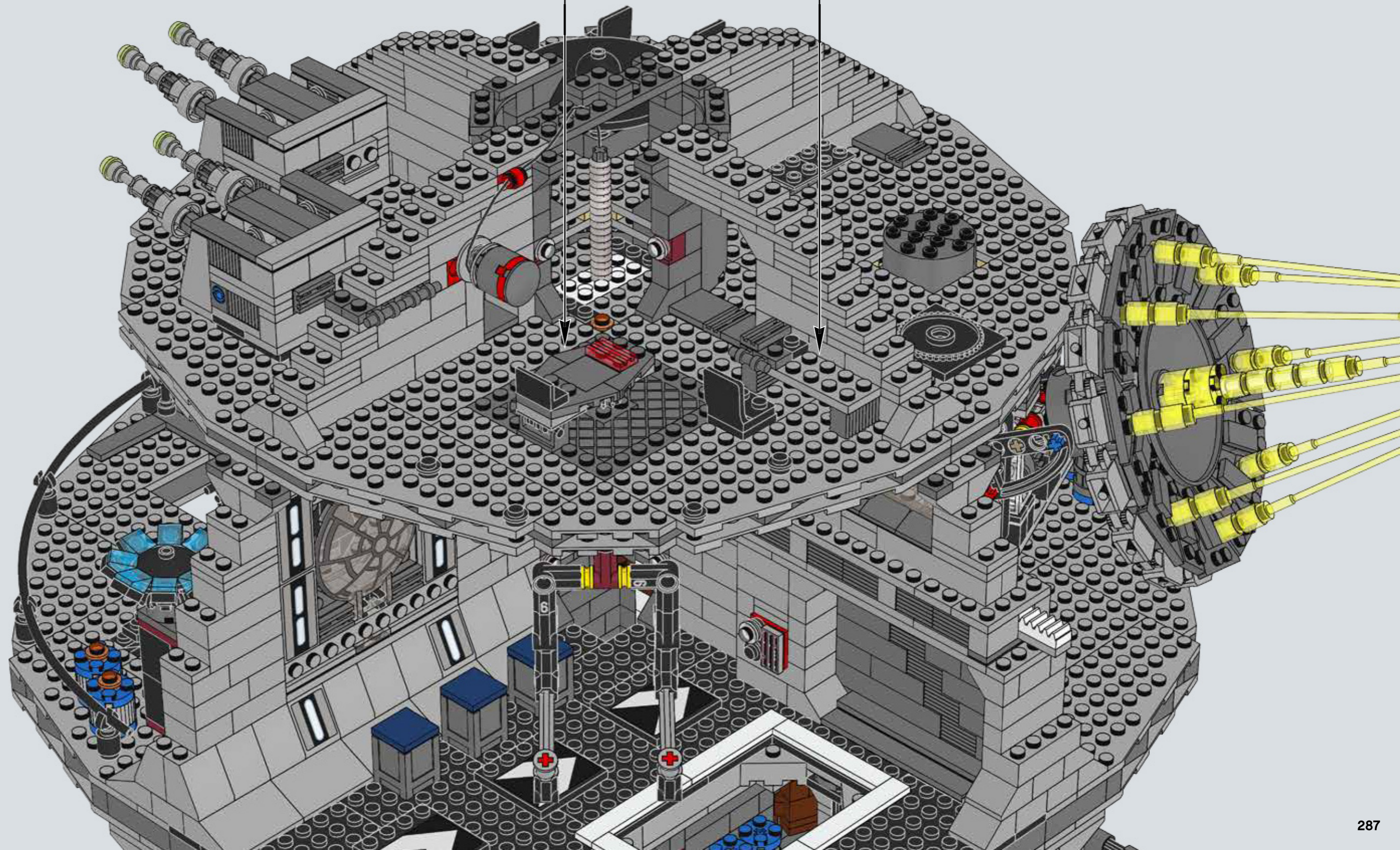
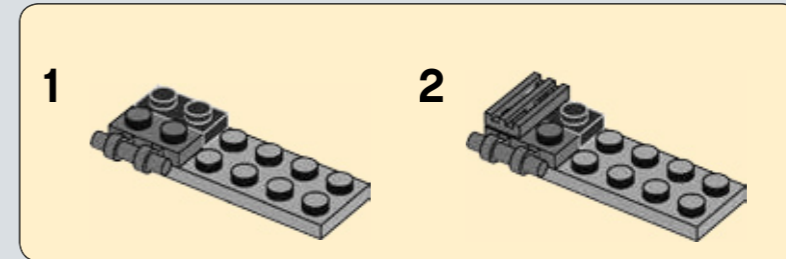
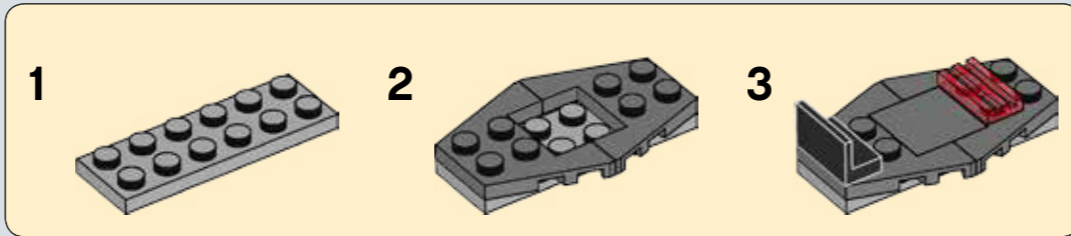

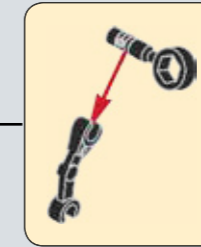
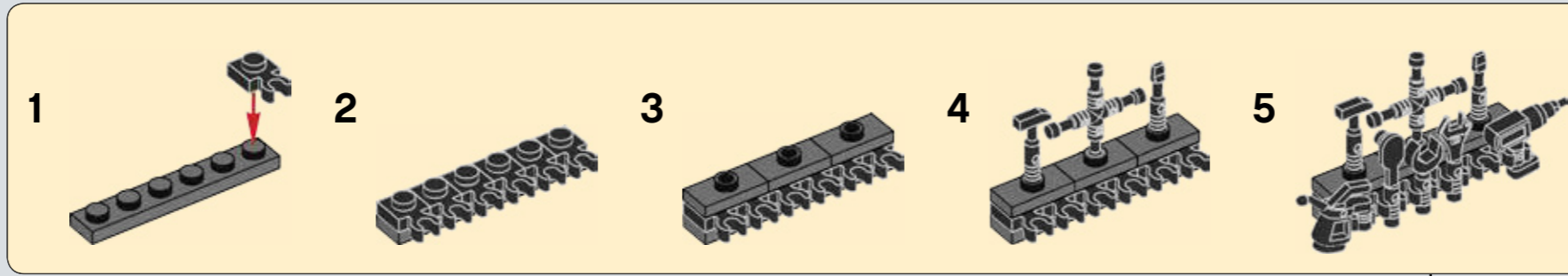
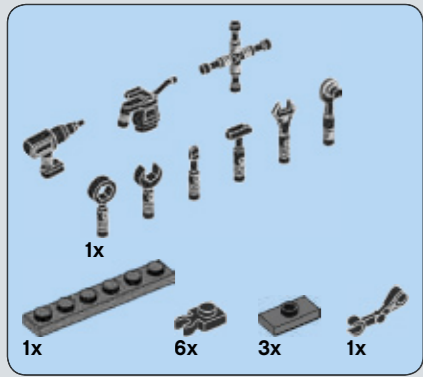

497

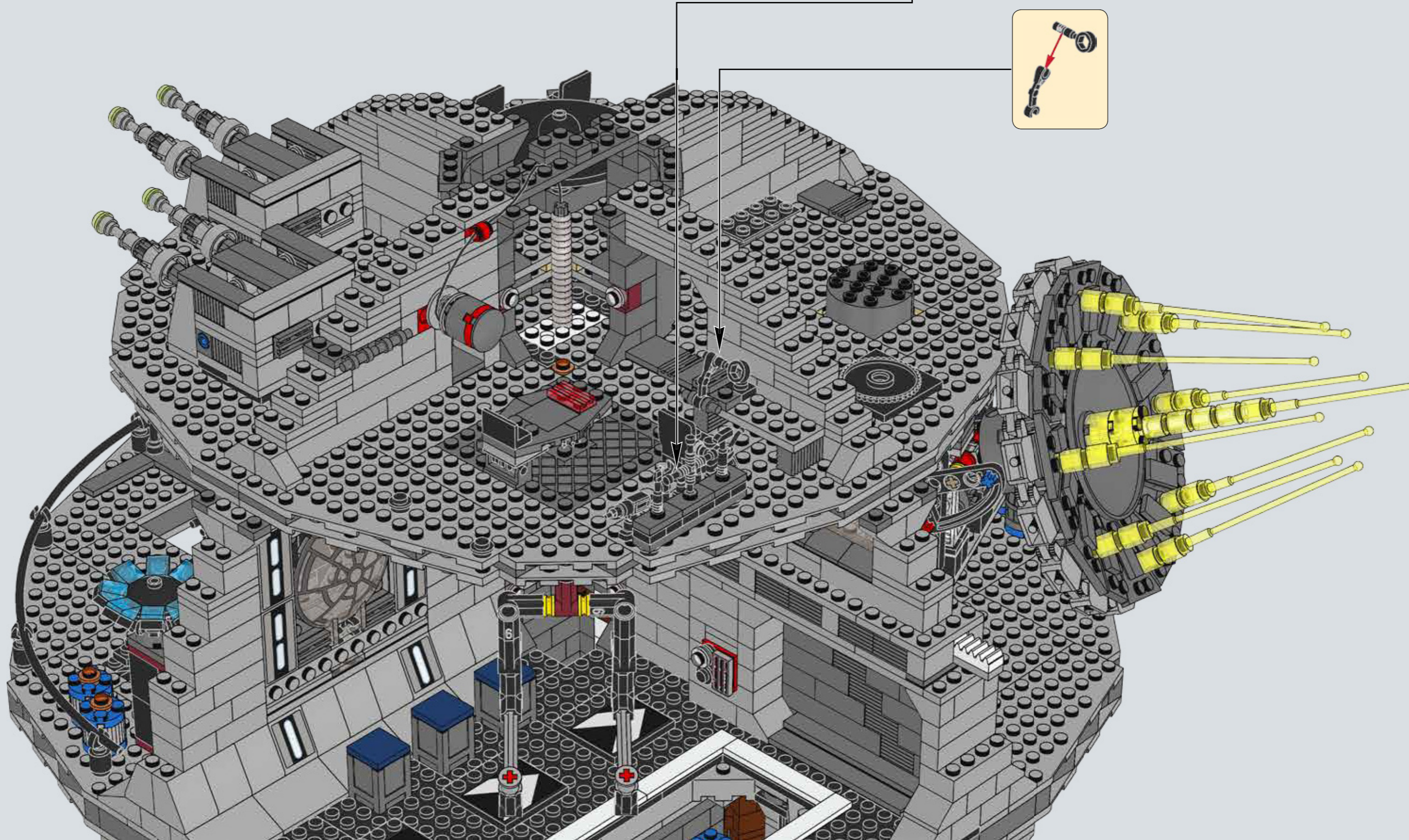



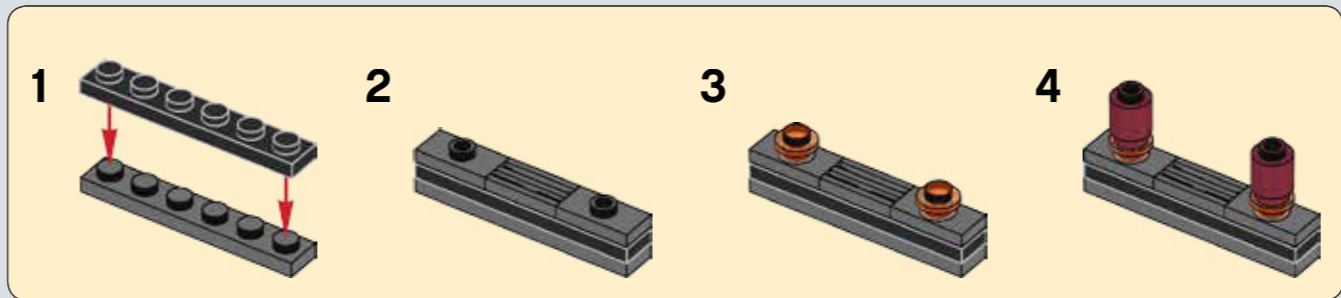
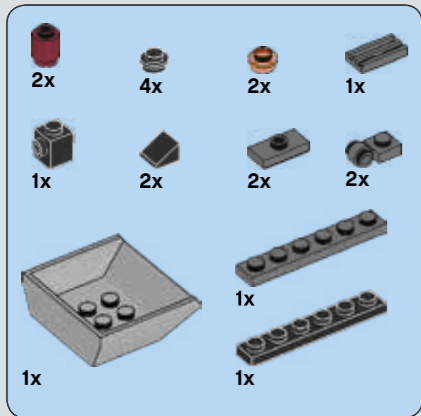

# 598

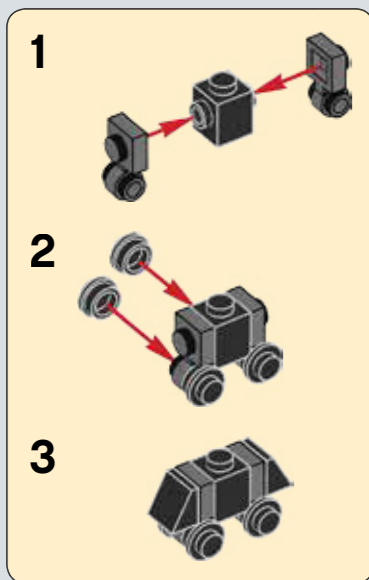

499

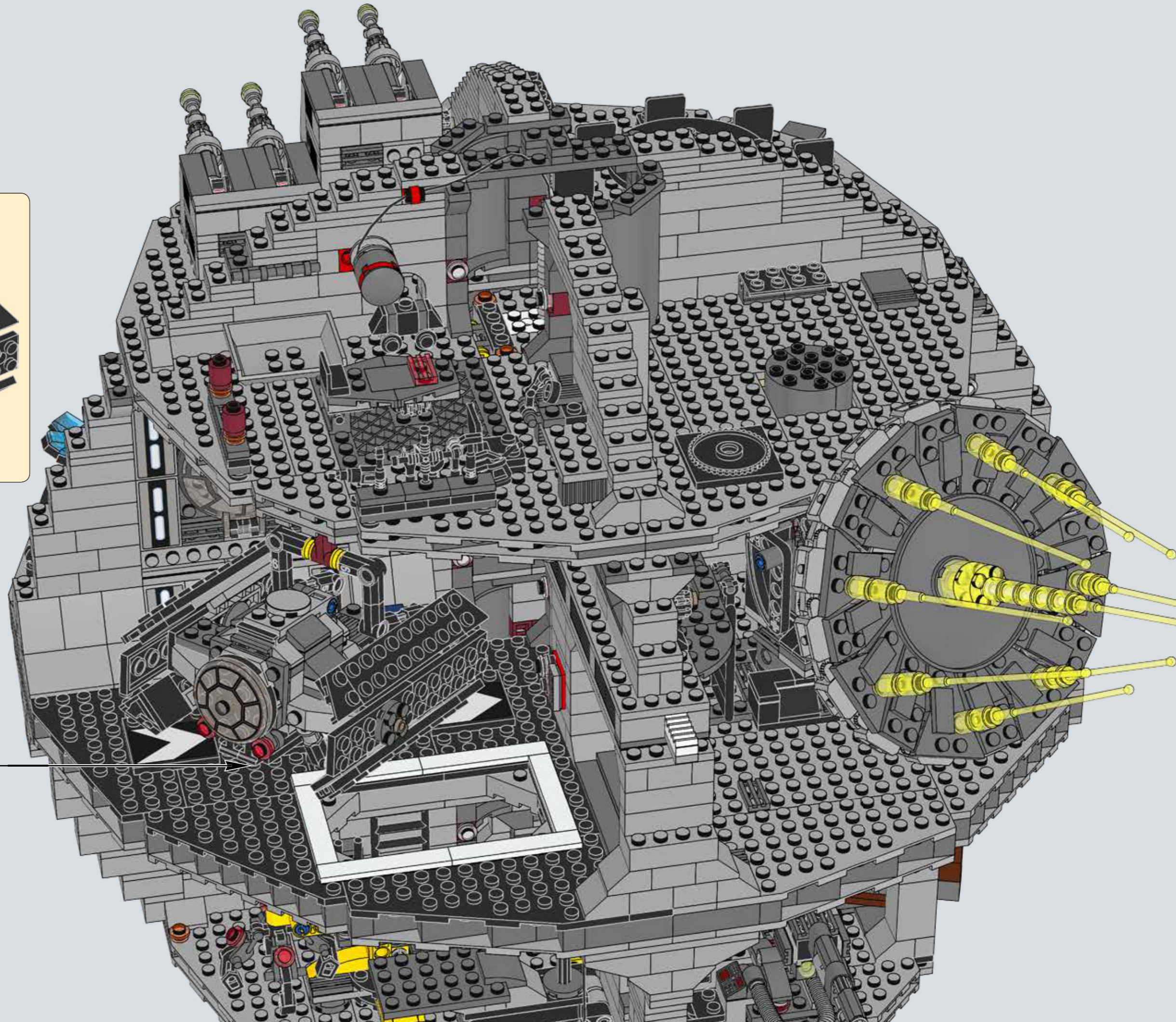
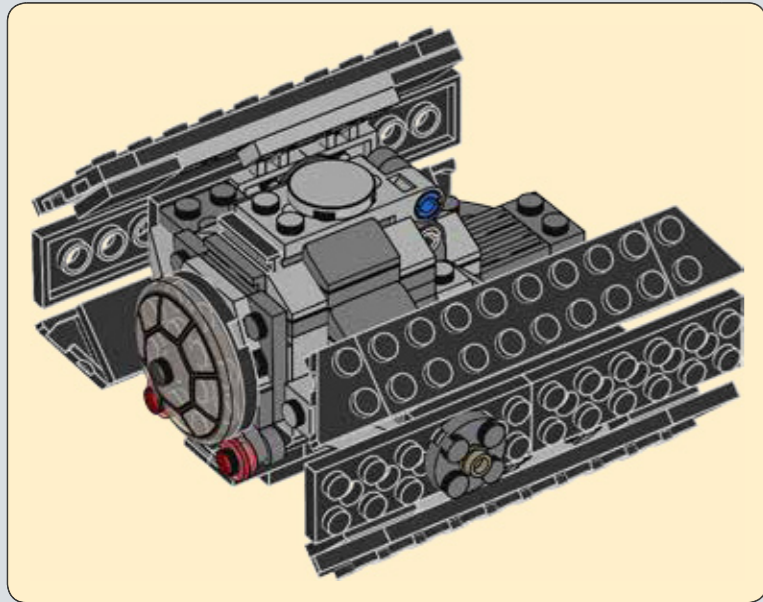

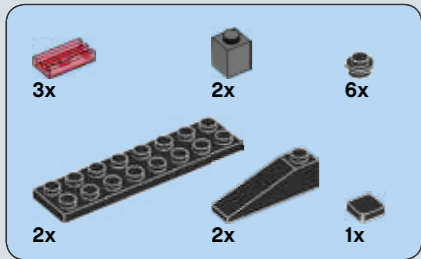

500

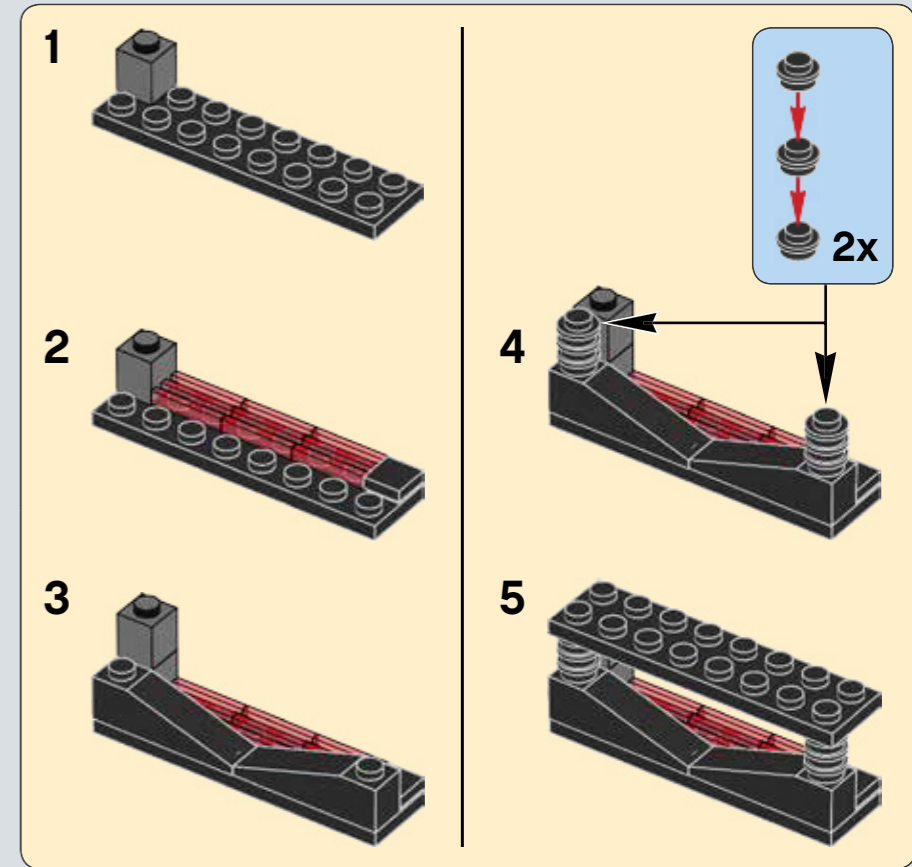
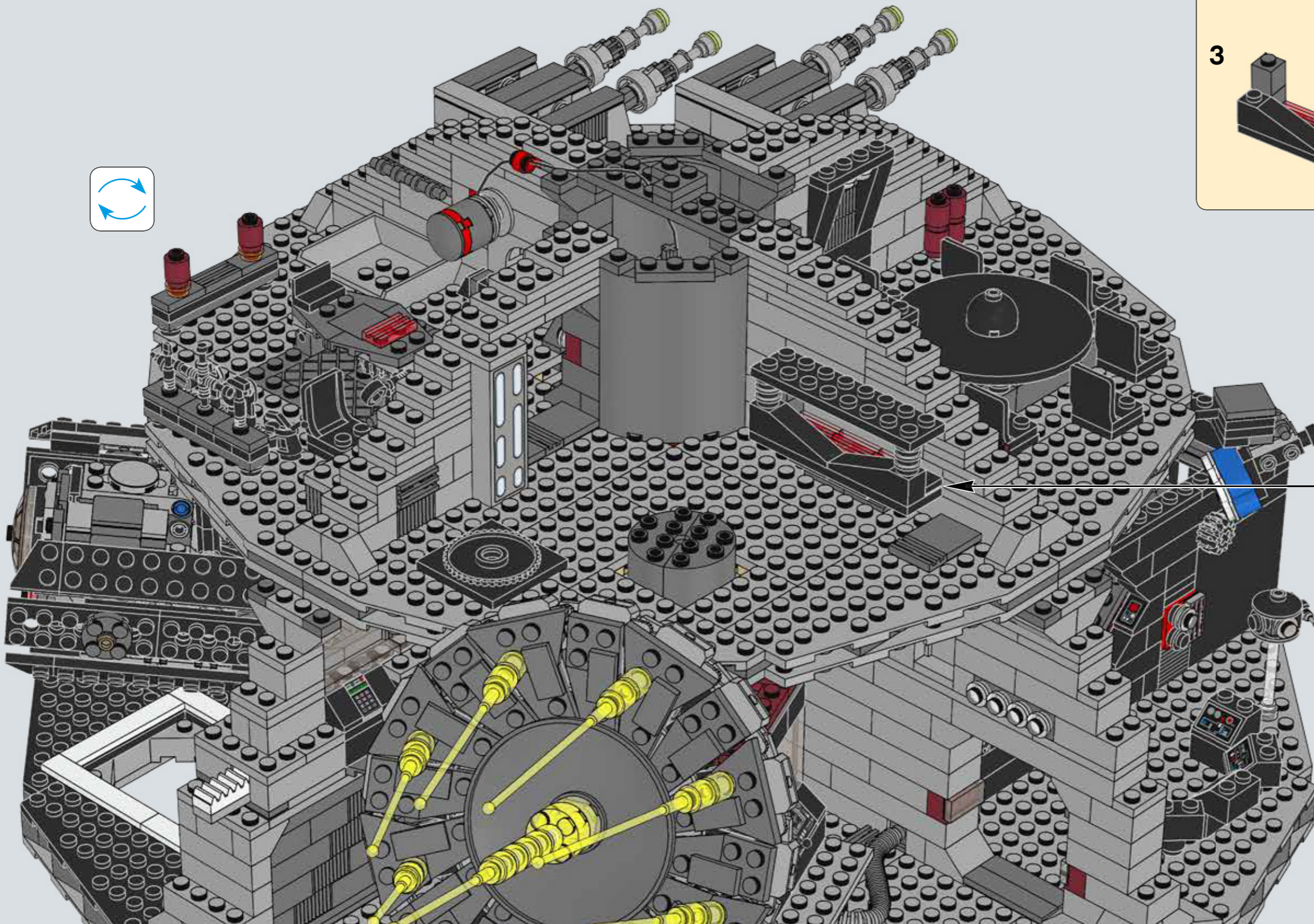
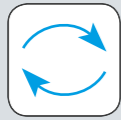

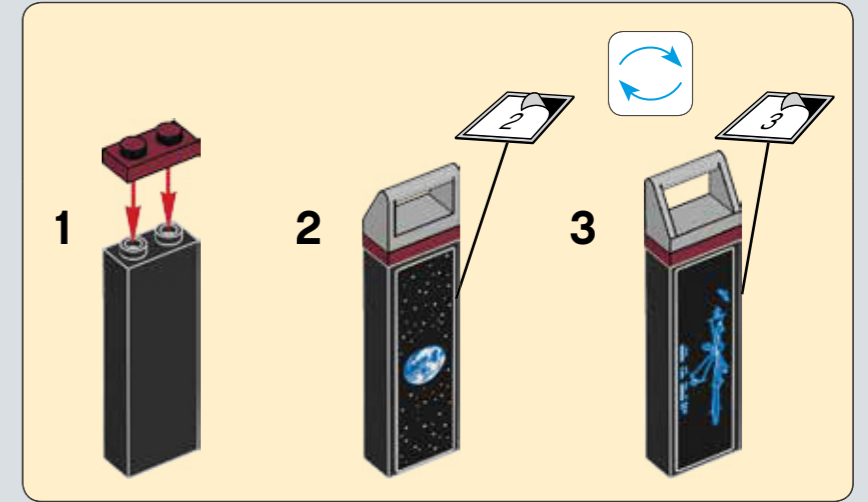
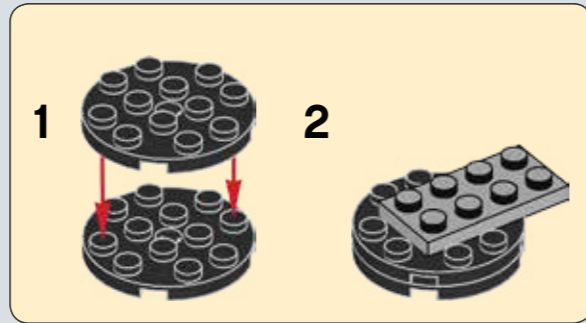
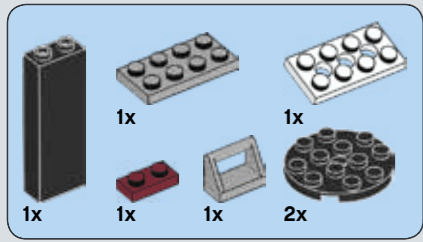

501

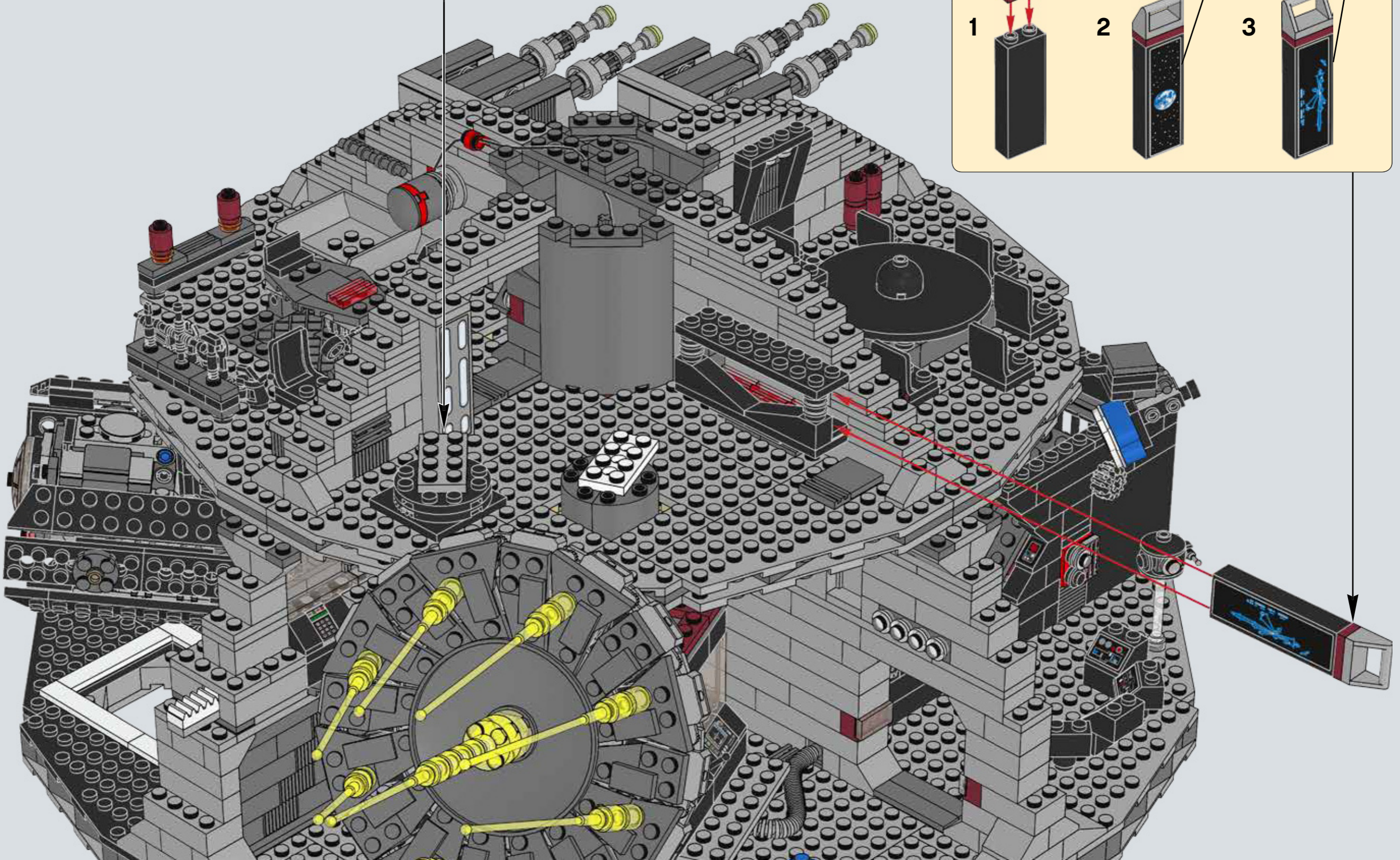

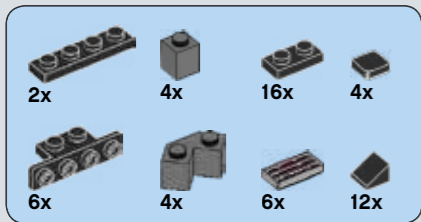

# 502

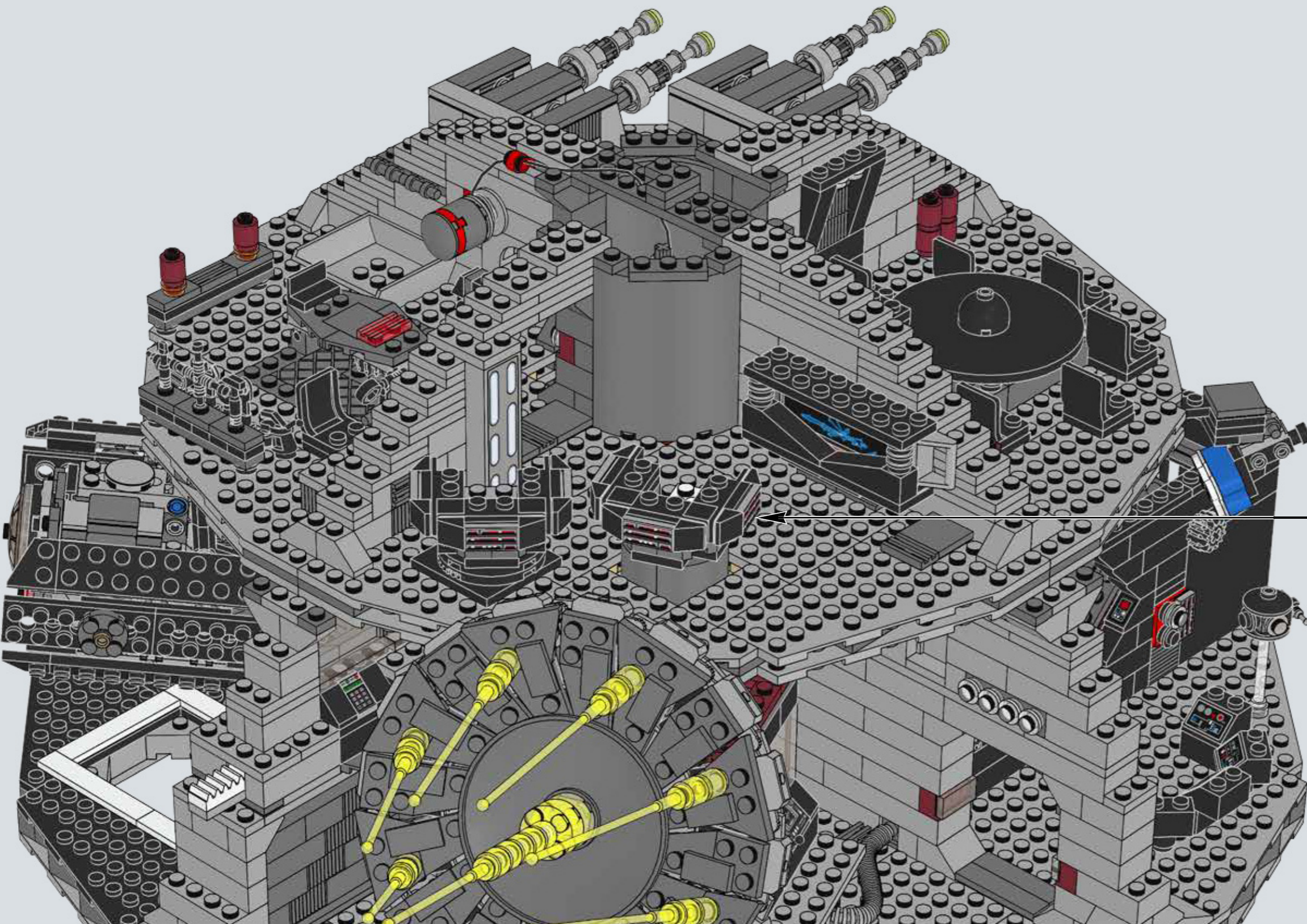

<p>1</p>	<p>5</p>
<p>2</p>	<p>6</p>
<p>3</p>	<p>1</p>
<p>4</p>	<p>2</p>
	<p>3x</p>
	<p>7</p> <p><b>2x</b></p>

12 1:1

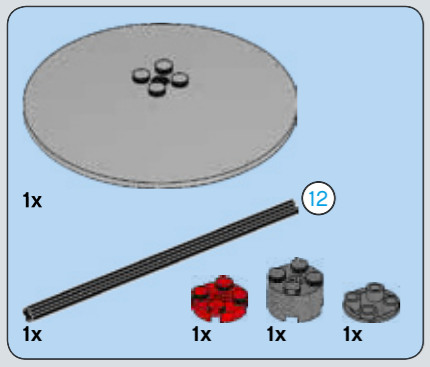

# 503

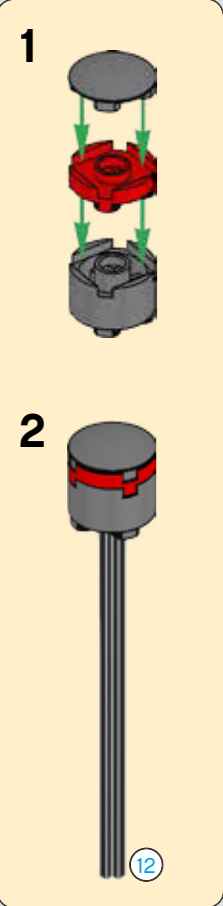

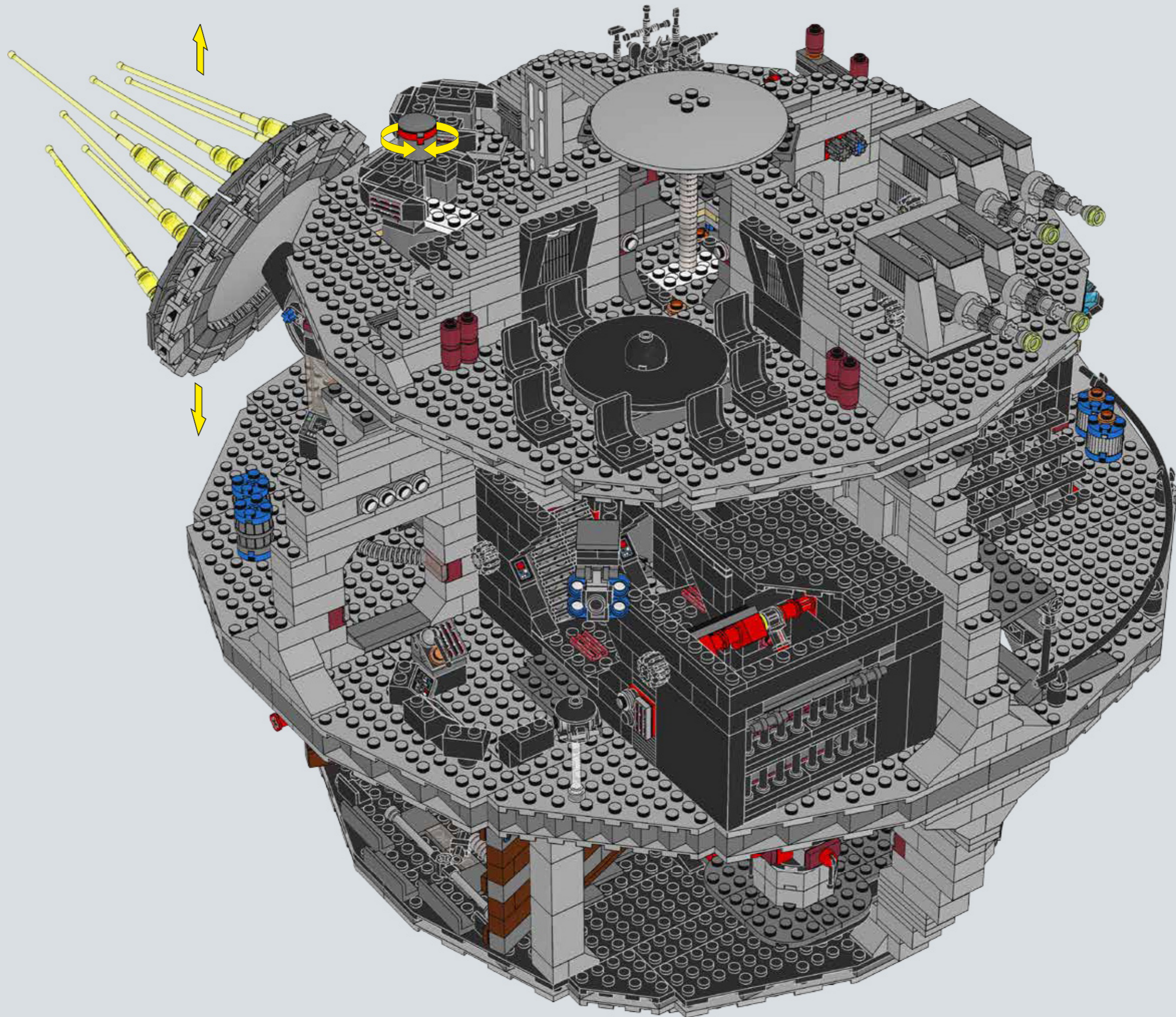

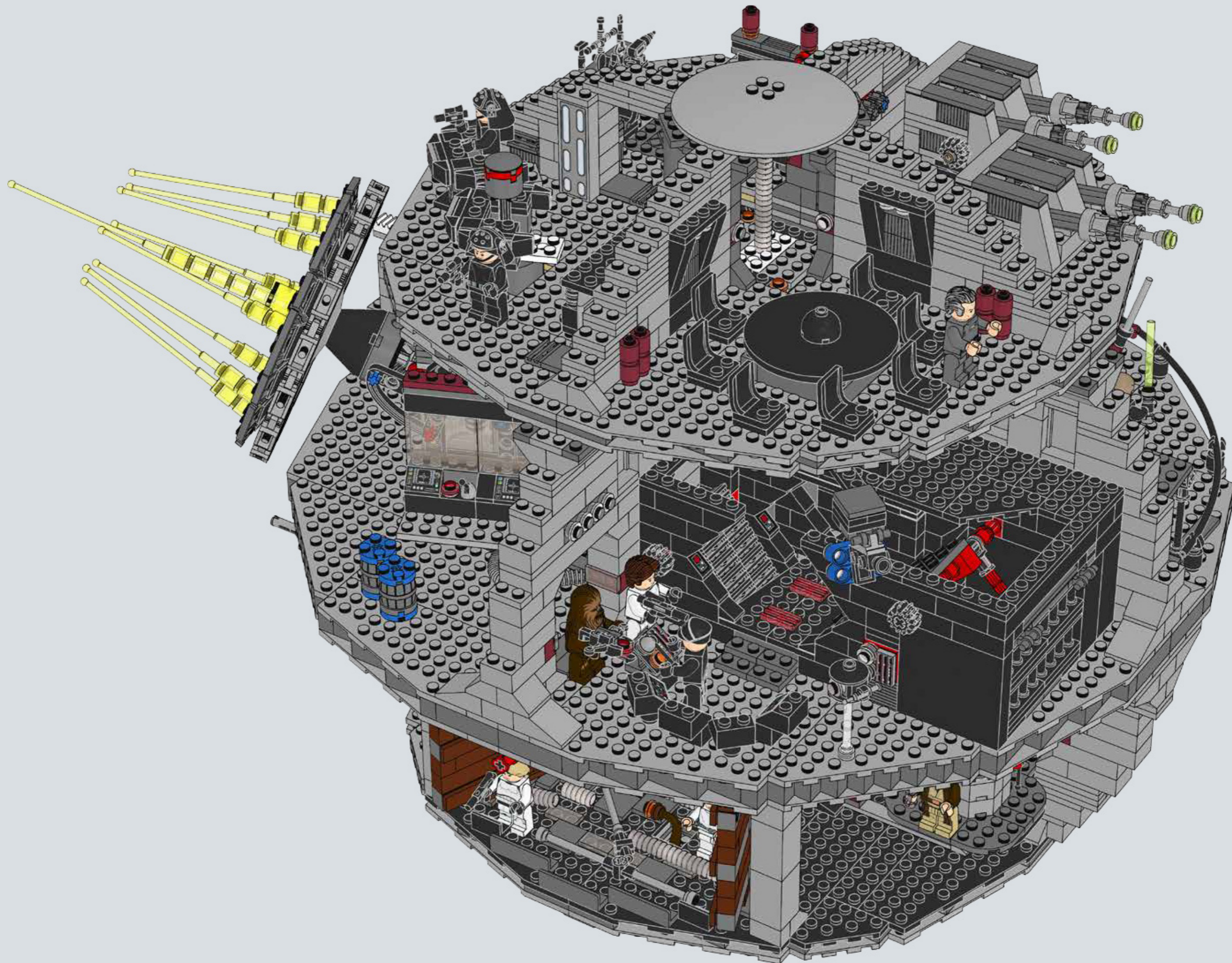





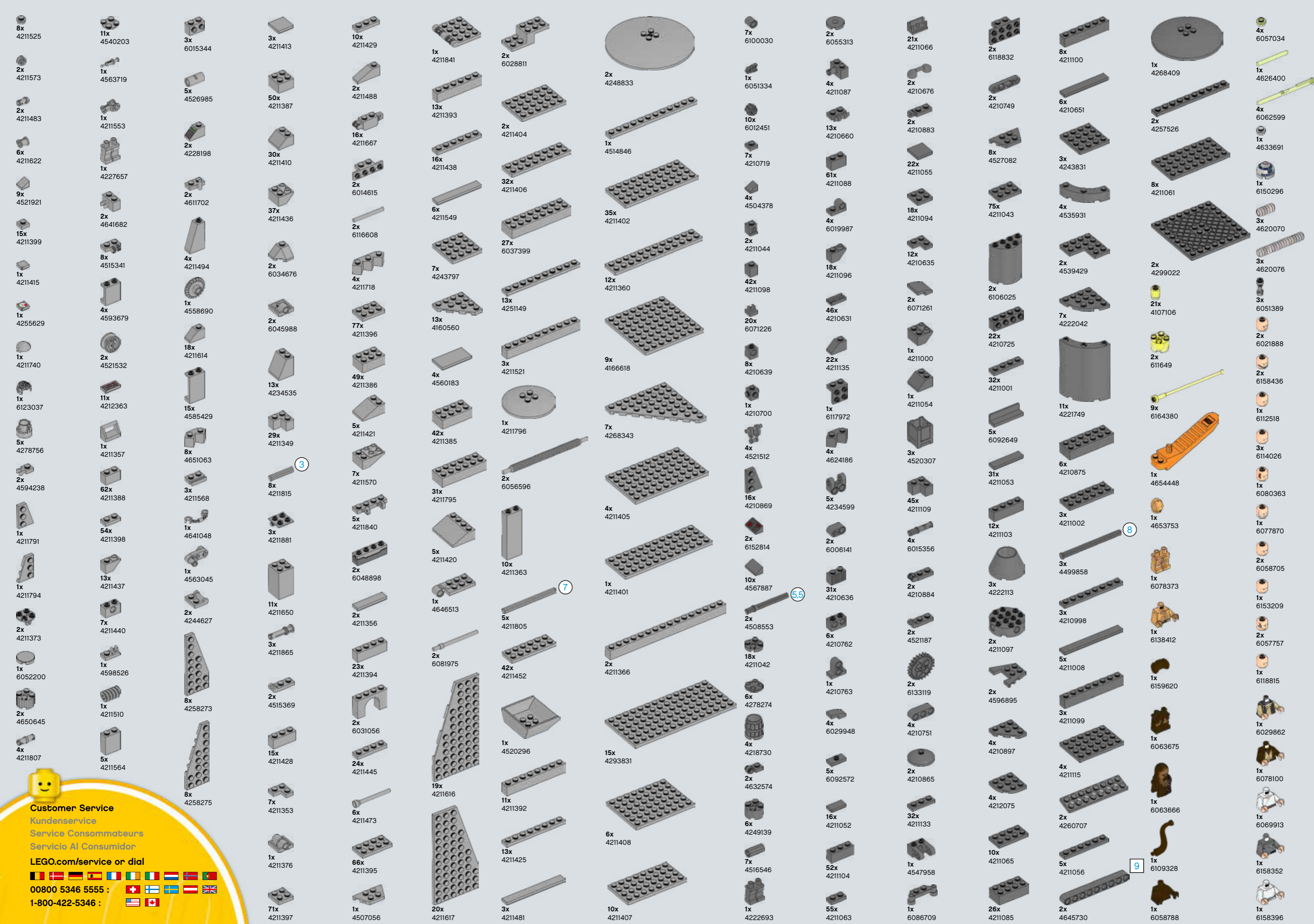

**Customer Service**  
 Kundenservice  
 Service Consommateurs  
 Servicio Al Consumidor  
[LEGO.com/service](http://LEGO.com/service) or dial  
 00800 5346 5555 :   
 1-800-422-5346 :

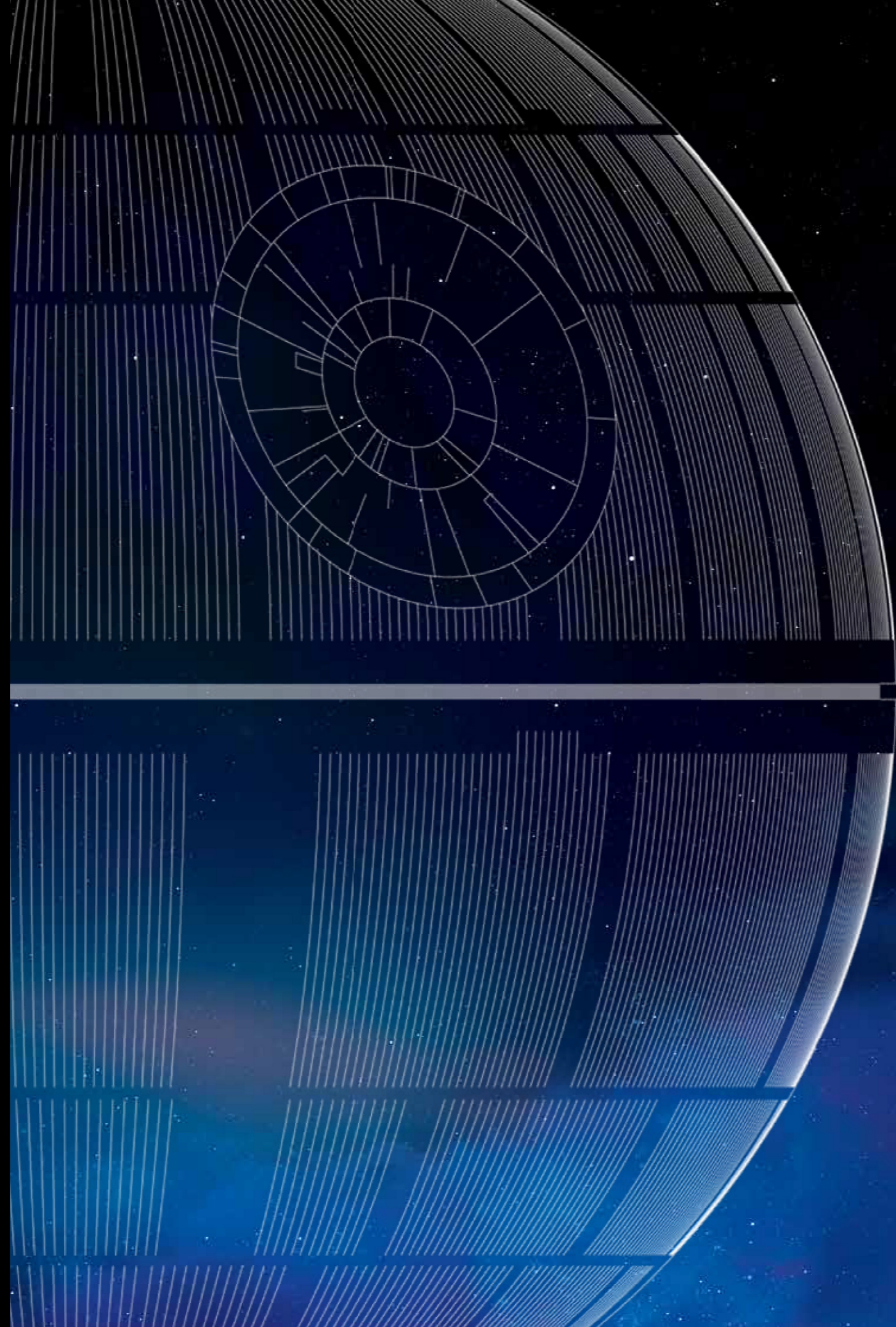

[LEGO.com/productfeedback](http://LEGO.com/productfeedback)

### GEWINNE



Erzähle uns auf  
[www.LEGO.com/productfeedback](http://www.LEGO.com/productfeedback)

etwas über die Erfahrungen, die du mit diesem LEGO® Set gemacht hast, und sichere dir die Chance auf einen coolen LEGO Preis!

Es gelten die Teilnahmebedingungen

### 获取奖品



登录  
[www.LEGO.com/productfeedback](http://www.LEGO.com/productfeedback)

给出关于此乐高®套装的简短反馈，就有机会获得炫酷乐高奖品

《条款及条件》适用

### GANAN



Visita  
[www.LEGO.com/productfeedback](http://www.LEGO.com/productfeedback)

y envíanos tu opinión acerca de este set LEGO®. ¡Participarás en el sorteo de un premio LEGO!

Términos y Condiciones aplicables

### GAGNE



Rends-toi sur  
[www.LEGO.com/productfeedback](http://www.LEGO.com/productfeedback)

et donne-nous quelques commentaires sur ce produit LEGO® pour avoir une chance de gagner un prix LEGO !

Voir Conditions Générales

### 경품 당첨 기회



[www.LEGO.com/productfeedback](http://www.LEGO.com/productfeedback)

페이지로 이동하여 이 레고® 세트에 대한 간략한 피드백을 보내 주시고 멋진 레고 경품을 탈 수 있는 기회도 잡으십시오

약관 적용

### ЗАПОЛНИ АНКЕТУ И ПОЛУЧИ ПРИЗ



Перейди по ссылке  
[www.LEGO.com/productfeedback](http://www.LEGO.com/productfeedback)

ответь всего на несколько вопросов об этом наборе LEGO®, и у тебя появится шанс выиграть замечательный приз от компании LEGO.

Применяются Условия и правила участия

